

**HOUSE OF
FINN JUHL**



***"One cannot create happiness with
beautiful objects, but one can spoil quite
a lot of happiness with bad ones"***

Finn Juhl

FINN JUHL IN SHORT 1912 – 1989

Finn Juhl was born on January 30, 1912 in Copenhagen. He wished to study art history, however, his father would not allow it. Instead, Finn Juhl began studying architecture at the Royal Academy of Arts in Copenhagen. Here, he studied under some of the most influential functionalists of his time. Among these was the great architect Vilhelm Lauritzen who hired Finn Juhl at his own studio in 1934 before Finn Juhl had even graduated. Eventually, the work took up all of his time and Finn Juhl never finished his studies. Later in life he always described himself as a self-taught furniture designer.

One of the international highlights of Finn Juhl's career was designing the complete interior of the Trusteeship Council Chamber at the UN headquarters in New York between 1951 and 1952. His sculptural furniture is widely appreciated all over the world. Today, Finn Juhl is still considered the father of Danish Modern, the design movement from Denmark, that arose during the 1950s in the United States. At the time of his death in 1989, Finn Juhl had become an award-winning and highly respected international furniture artist.

Finn Juhl blev født den 30. januar 1912 i København. Han ville gerne studere kunsthistorie, men det var hans far imod. I stedet begyndte Finn Juhl på uddannelsen til bygningsarkitekt ved Kunstakademiet i København. Her mødte han nogle af tidens mest indflydelsesrige funktionalister, blandt andet arkitekten Vilhelm Lauritzen, som ansatte ham i 1934. Efterhånden tog arbejdet al tiden fra studierne, og Finn Juhl fik aldrig afsluttet sin uddannelse. Han omtalte sig sidenhen altid som selvlært møbelformgiver.

Et af de internationale højdepunkter i hans karriere var designet af hele interiøret til FN's Formynderskabsrådssal i 1951-52. Finn Juhls skulpturelle møbler værdsattes verden over, og han regnes i dag som faderfiguren i udviklingen af Danish Modern i 1950'ernes USA. Ved sin død i 1989 havde Finn Juhl i sin karriere opnået at blive en prisvindende og højt respekteret international møbelkunstner.

“Art has always been my main source of inspiration. I am fascinated by shapes that defy gravity & create visual lightness”

Finn Juhl





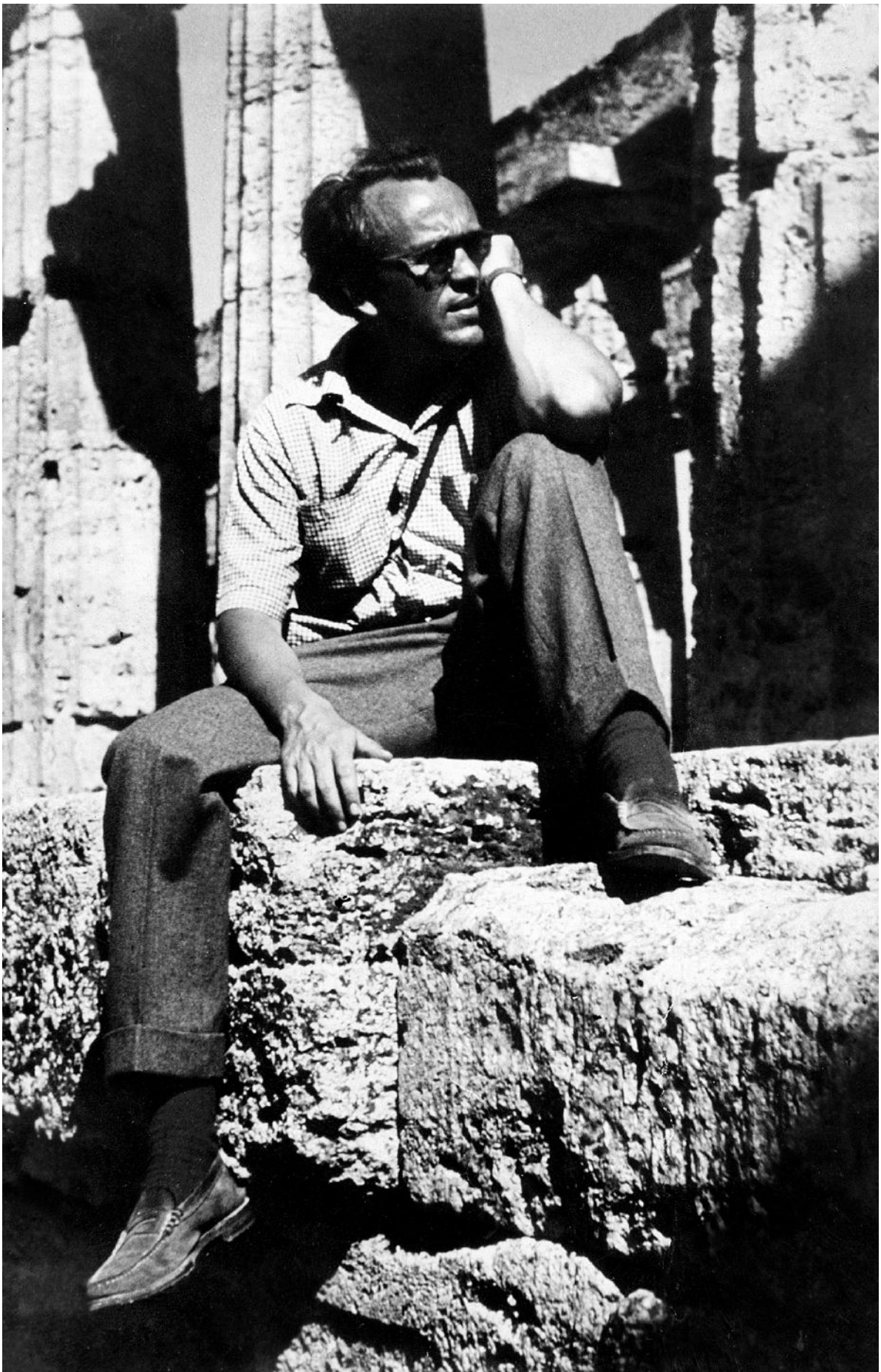

DESIGN FOR THE LIVING BODY THE ARTISTIC APPROACH

Finn Juhl was greatly inspired by both modernism in art and functionalism in architecture. His genius was cross-pollinating these two fields, thus creating a completely new artistic idiom. Like sculptures, Finn Juhl's designs are created to stand freely in a room. At the same time, they are developed with a playful insight into the practical function of every detail. This quickly becomes apparent as soon as you sit in one of his sofas or chairs. They are carefully created to support and hold the human body, and extremely comfortable whether you sit upright or put your feet up. For instance, the 57 Sofa with its built-in elbow-room. It will support you in whatever position you choose. Finn Juhl's shapes are always light with a dynamic twist. In other words, this is furniture for living in, not just living with.

Finn Juhl lod sig inspirere af samtidens moderne kunst, og med afsæt i funktionalismen, skabte han et helt nyt kunstnerisk formsprog. Møblerne møder øjet som skulpturer. De er skabt til at stå frit i rummet, men de er samtidig designet med en legende indlevelse i tingenes praktiske funktioner. Det mærkes tydeligt, når man sætter sig i en af hans sofaer eller stole. De er tænkt og skabt til at støtte og bære en levende krop, og de er yderst komfortable, uanset om man sidder ret op og ned eller slænger sig, eventuelt med benene placeret over armlænene. Formerne understøtter bevægelse og går samtidig meget længere i sit udtryk end selve funktionen. Ser man eksempelvis på 57-sofaen, så er der bogstavelig talt en albueplads i hjørnerne. Her finder man støtte, uanset om man læner sig op ad ryggen, eller sidder med fødderne oppe med ryggen hvilende mod armlænet. Det er ganske enkelt møbler, man lever i og ikke bare med.



A JOYFUL UNIVERSE ---

Venturing into Finn Juhl's universe of furniture is like embarking on a joyful journey. There are constantly new surprises waiting around the corner, both in terms of overall shapes and aesthetics as well as daring design details. For us, the journey began in 1998, when Finn Juhl's widow, Hanne Wilhelm Hansen, contacted us with a wish to have a single 57 Sofa produced. This was the beginning of a friendly partnership, which culminated in 2001 when she trusted us with the worldwide production rights of Finn Juhl's furniture. Exploring Finn Juhl's furniture universe is a constant adventure. We produce his designs in a modern reality but with the same values and strict demands for quality that he had in the originals. Re-launching Finn Juhl's furniture means that more of his designs can reach a large and dedicated audience worldwide. Now, when time has caught up with Finn Juhl's pioneering ideas, his furniture can finally live up to its full potential and create joy for its users.



At begive sig ind i Finn Juhls møbelunivers er en glædesfyldt rejse. Der er hele tiden nyt at opleve, både i forhold til de overordnede former og funktioner og ned i de mindste detaljer. For os begyndte denne rejse i 1998, da Finn Juhls enke, Hanne Wilhelm Hansen, kontaktede os med et ønske om at få produceret en 57-sofa. Det blev indledningen til et venskabeligt samarbejde, der kulminerede i år 2001, da Hanne Wilhelm Hansen overdrog rettighederne til produktion af Finn Juhls møbler til os. Arbejdet med Finn Juhls møbler er fortsat en spændende rejse for os. Vi producerer i dag møblerne til brug i en moderne virkelighed, men med samme værdier og krav til kvalitet, som de oprindelige. Relanceringen betyder, at flere af Finn Juhls designs finder vej til et stort og dedikeret publikum over hele verden, nu hvor tiden er moden til dem.

ØDRUPGAARDS PARK.

DYREHAVEN

PROJ. TILBYGNING



EGET HUS, KRATVENGET 15. 1:100
BYGGET 1911-1942

KRATVENGET 15
CHARLOTTEENLUND
DENMARK
FINN JUHL
ARCHITECT M.A.A.
ØDRUP 7721
ØDRUP 8008

AUGUST 1970

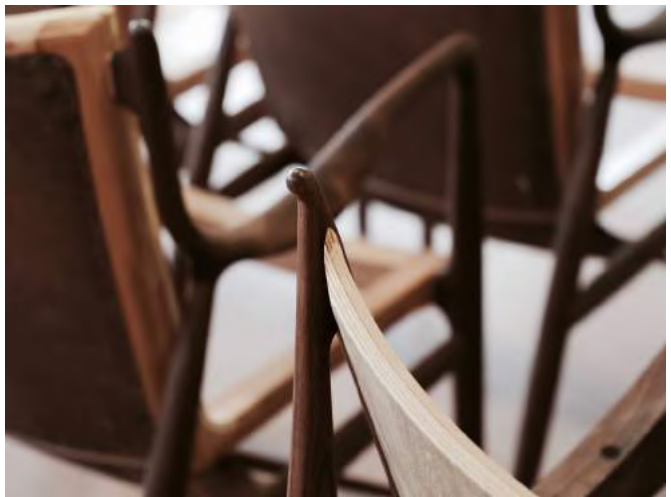

RELAUNCHING FINN JUHL'S FURNITURE

Our passion is to relaunch Finn Juhl's furniture, in respect of his legacy, but in a modern reality. The details must be as fine and pure as if they came from the original cabinetmakers' workshop but our understanding of quality also includes durability. Our furniture has to be so durable that they can be enjoyed by users today and by generations to come.

Today, our House of Finn Juhl furniture is mainly manufactured in Denmark. Our upholstered furniture, such as the Poet Sofa and the Pelican Chair, are entirely upholstered by hand in the same Danish tradition as always. However, when it comes to our wooden furniture, we have chosen to utilise modern technology, which goes hand-in-hand with excellent craftsmanship in order to make Finn Juhl's visions come true. For instance, the Chieftain Chair's intricately shaped wooden frames are masterly crafted by our skilled Japanese friends in Yamagata.

Without this approach, it would not be possible to achieve the fantastic finish and delicate detail that was Finn Juhl's trademark. Besides, several of Finn Juhl's iconic designs would never be produced because they would have been too delicate to use. Finn Juhl himself was aware of this and famously said:

"One shouldn't despair over the fact that some of the developments one has hoped for were never produced but only became a beginning. Perhaps they will be revived some day in the future when the time is ripe."

Vores passion er at relancere Finn Juhls møbler, med respekt for arven og traditionen, men i en moderne virkelighed. De skal i detaljer være lige så fine og lige så originale som dem, de gamle snedkermestre udførte, men vores forståelse for kvalitet betyder også, at møblerne skal kunne holde til at blive brugt og være til glæde for nuværende og kommende generationer.

Vores House of Finn Juhl kollektion er i dag hovedsageligt fremstillet i Danmark. Vores polstermøbler som Poetsofaen og Pelikanstolen er produceret efter den danske håndværkstradition og er håndsyet i Danmark som oprindeligt. I forhold til træmøblerne gør vi i dag brug af moderne produktionsteknologi, der i Finn Juhls møbler går hånd i hånd med ypperligt snedkerhåndværk. De mest dristigt udformede træmøbler med organiske former er mesterligt udført hos vores japanske venner i Yamagata.

Uden denne tilgang er det ikke muligt at opnå den fantastiske finish og de delikate detaljer, som er Finn Juhls varemærke. Flere af Finn Juhls ikoniske møbler ville heller aldrig kunne blive produceret, fordi de ikke ville kunne holde til at blive brugt. Finn Juhl var selv opmærksom på dette og har engang sagt:

"Man skal ikke være så fortvivlet over, at de udviklinger man af og til har ønsket sig, at de ikke er blevet til noget, men kun er blevet til en begyndelse. De bliver måske taget op en anden gang, hvis det er nødvendigt, og hvis det er rimeligt, og hvis tiden er moden".

PELICAN CHAIR 1940

In no other design of his is Finn Juhl's fascination for surrealism more apparent than in the Pelican Chair. Out of all of his many designs, the Pelican Chair was probably the one furthest ahead of its time. When it was presented at the Copenhagen Cabinetmakers' Guild Exhibition in 1940, it stood out with its unusual shape and sturdy legs. Finn Juhl normally named his furniture numbers after the year in which they were designed, but over time the nickname "Pelican" stuck to the chair.

Very few were manufactured and the chair was almost forgotten until we rediscovered and relaunched the chair in 2001. The characteristic soft and organic shape is almost like a body holding a body. When you sit down, the chair practically gives you a friendly hug. Like many of Finn Juhl's later designs, the chair offers several comfortable ways to sit.

The sculptural chair fits seamlessly into most modern interior styles and works particularly well with the Pelican Table and its close relative, the Poet Sofa from 1941.

The Pelican Chair is produced in two versions - with or without buttons. It is manufactured with a cushion and a handsewn upholstery in fabric or leather. The legs are available in teak, oak, walnut and black painted.

Finn Juhls kærlighed til den frie og skulpturelle kunst afspejler sig tydeligt i Pelikanstolen. Den overpolstrede lænestol er vel nok dét af Finn Juhls møbler, der var mest forud for sin tid. Da den blev præsenteret på Snedkerlaugets udstilling i 1940, stak den ud med sine aparte former og tykke ben. Finn Juhl navngav normalt sine møbler med numre, der forholdt sig til året, hvori de var tegnet, men over tid kom kælenavnet "Pelikanen" til at hænge fast.

Der blev kun produceret ganske få eksemplarer, og stolen gik nærmest i glemmebogen, indtil vi genopdagede den og valgte at relancere den i 2001. Stolen karakteristiske, bløde og organiske form er som en krop, der holder om kroppen. Man sætter sig og får et venligt kram. Som mange af Finn Juhls senere værker indbyder Pelikanstolen også til flere behagelige måder at sidde på.

Den skulpturelle stol passer godt til nutidens interiører og står helt perfekt sammen med Pelikanbordet, tegnet samme år, og sin nære slægtning Poetsofaen, fra 1941.

Pelikanstolen produceres i to versioner – en med knapper og en uden. Stolen leveres med en løs hynde og er med håndsyet betræk i stof eller læder. Benene fås i teak, eg, valnød eller sortmalet.

PRODUCT INFO

MODEL	FJ 4000 (w/o buttons) FJ 4001 (w/ buttons)
YEAR	1940, relaunched in 2001
MATERIALS	Legs: Teak, oak, walnut, black painted Upholstery: Fabric, leather
DIMENSIONS	Size: W 85cm x D 76cm x H 68cm Seat height: 37cm Weight: 25kg Cbm: 0.60m ³ Fabric consumption: Body: 3.35m Cushion: 0.60m

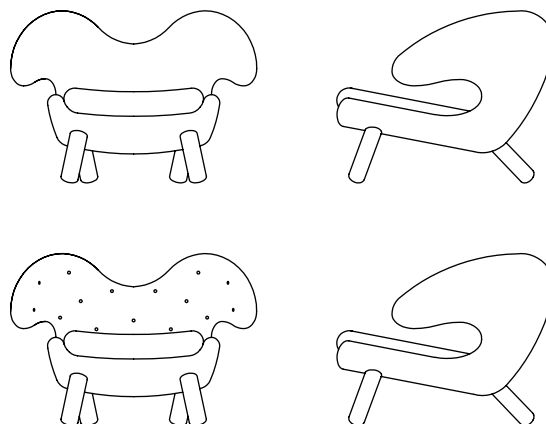





PELICAN CHAIR 1940
BY **FINN JUHL**

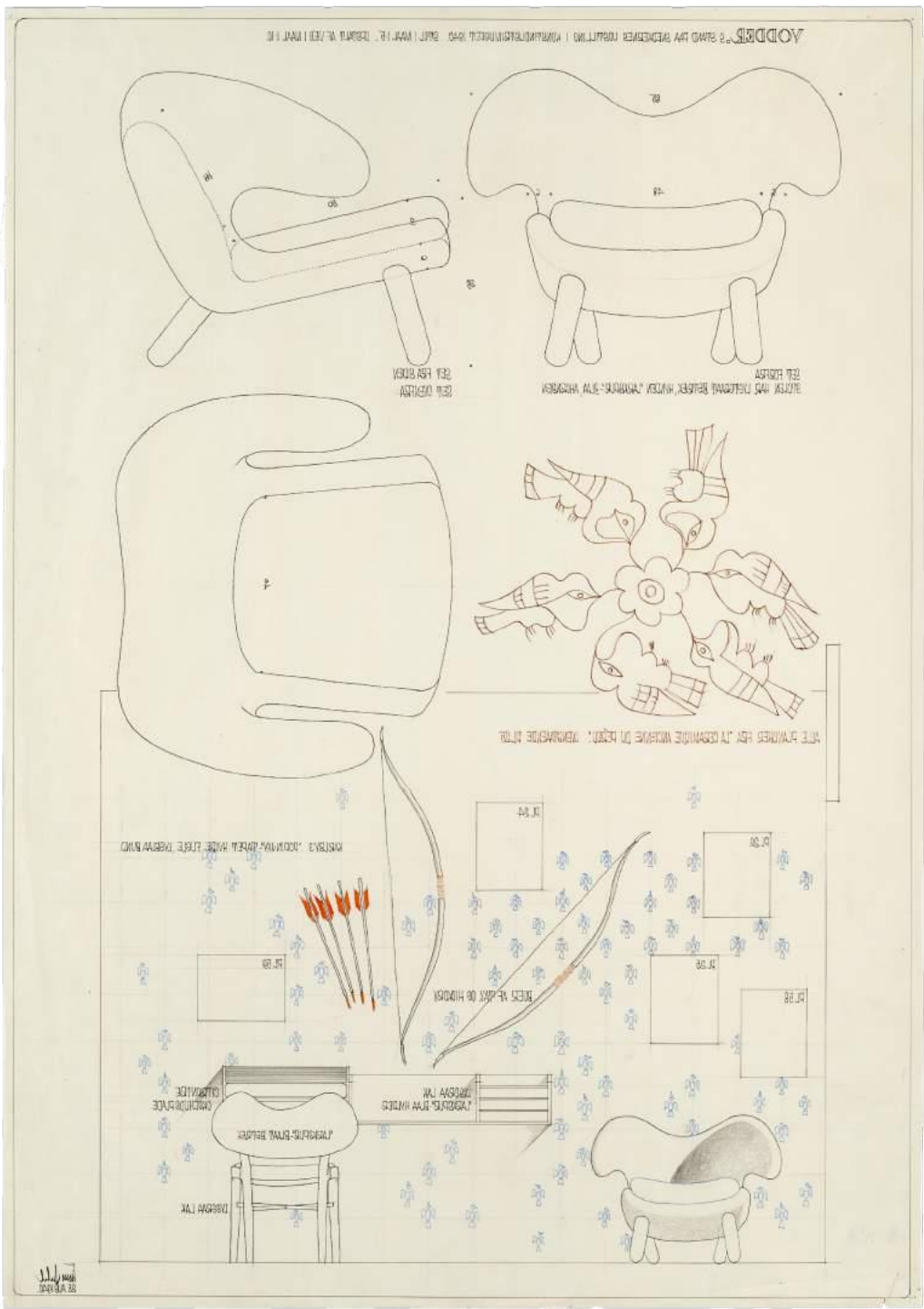

“Presumably, the creative capabilities of a craftsman are the same as those of a sculptor. A chair is not just an industrial product in a space. It becomes form and space itself”

Finn Juhl



PELICAN CHAIR 1940
BY FINN JUHL



PELICAN TABLE 1940

The only known version of this table was displayed with two Pelican Chairs at the Copenhagen Cabinetmakers' Guild Exhibition in 1940. As far as we know, it was never produced again. Both the Pelican Chair and the Pelican Table are exceptional examples of Finn Juhl's spiritual kinship with modern art. He handpicked particular artifacts, which were exhibited together with his furniture at the exhibition.

No drawings of the table exist - only a photograph of the table from the exhibition together with two Pelican Chairs. When the original table suddenly reappeared at an auction in Paris almost 75 years later, the accurate dimensions and measurements of the table could finally be determined.

Today, the Pelican Table is manufactured in teak, oak, walnut, Oregon pine or black painted.



Den eneste kendte udgave af dette bord blev fremvist sammen med to Pelikanstole på Snedkerlaugets udstilling i besættelsesåret 1940 og blev, så vidt vi ved, aldrig senere sat i produktion. Både Pelikanstolen og Pelikanbordet er eminente eksempler på Finn Juhls åndsslægtskab med moderne billedkunstnere fra hans samtid. Han håndplukkede særlige kunstværker og viste dem sammen med sine møbler ved udstillingen.

Der findes ingen tegning af bordet, kun et billede fra laugsudstillingen i 1940, hvor det er fotograferet sammen med to Pelikanstole. Da bordet pludselig dukkede op i et auktionskatalog i Paris, næsten 75 år efter at det var vist første gang, kunne bordets størrelse og dimension endelig fastlægges.

I dag fremstilles Pelikanbordet i teak, eg, valnød, Oregon pine og sortmalet.

PRODUCT INFO

MODEL	FJ 4063
YEAR	1940, relaunched in 2014
MATERIALS	Teak, oak, walnut, Oregon pine, black painted
DIMENSIONS	Size: Ø 63cm x H 45cm Weight: 9kg Cbm: 0.23m ³

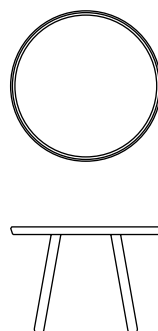



POET SOFA 1941

This small two-seater sofa first saw the light of day at the Copenhagen Cabinetmakers' Guild Exhibition in 1941. It should be seen as a natural progression from the Pelican Chair that was displayed the previous year. The upholstery is very slim compared to the norm at the time and it was the result of Finn Juhl's ambition to create functional furniture for smaller apartments.

The Poet Sofa is also one of Finn Juhl's experiments for his own home. At the Guild Exhibition, the sofa was shown together with a couple of plaster reliefs by artist Sigurjón Ólafsson. In this way, he indicated the link between furniture and sculpture. The small sofa is a very comfortable embrace for two people, who will be sitting comfortably close.

The small sofa received its name much later, in 1959, when a popular Danish cartoonist depicted the exact sofa as the place where a young poet would withdraw to contemplate the complexities of life.

The Poet Sofa is available in the same execution as the Pelican Chair - with handsewn upholstery in fabric or leather and with legs in teak, oak, walnut or black painted.

Den lille topersoners sofa blev vist på Snedkerlaugsudstillingen i 1941, og bør betragtes som en videreudvikling fra Pelikanstolen, som blev vist frem året før. Polstringen er, efter tidens forhold, særdeles slank, og følger Finn Juhls idé om at skabe gode funktionelle møbler, som kan bruges i mindre lejligheder.

Poetsofaen er også et af Finn Juhls eksperimenter, som han tegnede til sit eget hjem. På snedkerlaugsudstillingen havde Finn Juhl ophængt et par gipsrelieffer af kunstneren Sigurjón Ólafsson, der angav slægtsskabet til samtidens kunst. Sofaen er som en omfavnende krop til to personer, der sidder umådeligt godt, men også så tæt, at man let kommer til at trække på smilebåndet.

Den lille sofa fik først sit navn i 1959, da den optrådte i en populær tegneseriestribe i Politiken, skabt af Jørgen Mogensen, ved navn "Poeten og Lillemor". Den handlede om en ung digter, der ofte lå på netop denne sofa og reflekterede over livets tildragelser.

Poetsofaen leveres i samme udførelse som Pelikanstolen - med håndsyet betræk i stof eller læder og med ben i teak, eg, valnød eller sortmalet.

PRODUCT INFO

MODEL	FJ 4100
YEAR	1941, relaunched in 2001
MATERIALS	Legs: Teak, oak, walnut, black painted Upholstery: Fabric, leather
DIMENSIONS	Size: W 136cm x D 80cm x H 87cm Seat height: 38cm Weight: 38kg Cbm: 1.03m ³ Fabric consumption: Body: 4.90m Cushion: 1.10m

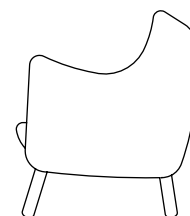
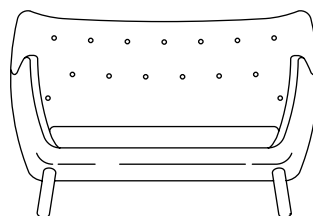
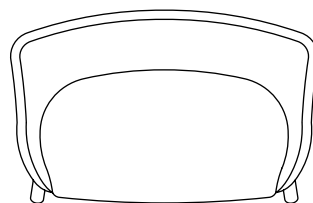







POET SOFA 1941
BY FINN JUHL

46 SOFA 1946

As the name suggests, this sofa was designed in 1946. The sofa was manufactured by the upholsterer Carl Brørup in his workshop in Copenhagen.

As a young man, Finn Juhl had a dream of becoming an art historian. During the 1930s and 1940s he had been strongly influenced by modern art, which was the main reason his designs took on such organic shapes with almost human-like features. He worked from the core and outwards in similar fashion to that of a surrealist artist, and was inspired by the freedom from convention reflected in art.

Just like the Pelican Chair, the 46 Sofa is also a "body for the body". Only this "body" can accommodate two people who become one organic unit. Finn Juhl's artistic license was heavily criticized at the time as some critics scornfully called his furniture "tired walruses".

Viewed by today's eyes, the 46 Sofa is a charming and cosy addition to any interior style - classic as well as modern. The sofa is masterfully built, consisting of a solid wooden frame with springs in the cushion and entirely handsewn upholstery. It is available in fabric or leather with legs in teak, oak, walnut or black painted.

46-sofaen er, som navnet angiver, tegnet i 1946. Sofaen blev produceret af polstermester Carl Brørup i Blågårdsgade på Nørrebro i København.

Finn Juhl havde haft en drøm om at blive kunsthistoriker og var i 1930'erne og 40'erne stærkt inspireret af den frie fabulerende kunst, hvilket var grunden til, at hans møbler fik organiske former med nærmest menneskelig karakter.

Han arbejdede indefra og ud, på samme måde som de surrealistiske kunstnere, og var optaget af den humanistiske frigjorthed, som kunsten afspejlede. I lighed med Pelikanstolen er 46-sofaen også en krop til kroppen. Denne krop huser bare to personer, der siddende i sofaen bliver en organisk helhed.

Finn Juhl blev i sin samtid stærkt kritiseret for det kunstneriske formsprog i sine møbler, som man nedladende kaldte for bl.a. "trætte hvalrosser".

I nutidens moderne virkelighed er 46-sofaen et hyggeligt og charmerende indslag til enhver indretning - klassisk eller moderne. Sofaen er håndværksmæssigt et mesterligt bygget møbel på en massiv træramme, med fjederindlæg i sædet og håndsyet polstring. Den leveres med stof eller læder med ben i teak, eg eller valnød.

PRODUCT INFO

MODEL	FJ 4600
YEAR	1946, relaunched in 2008
MATERIALS	Legs: Teak, oak, walnut, black painted Upholstery: Fabric, leather
DIMENSIONS	Size: W 132cm x D 75cm x H 80cm Seat height: 42cm Weight: 42kg Cbm: 0.99m ³ Fabric Consumption: Body: 4.00m Seat: 1.10m

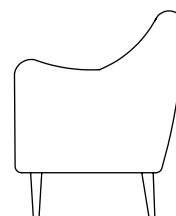
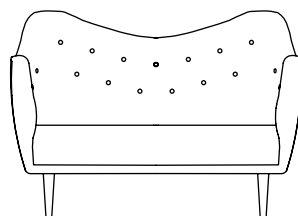
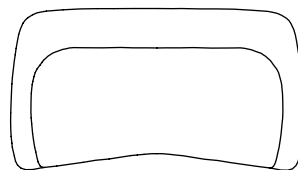





“When my furniture is called sculptural, it is in relation to humans, who are sculptural. But that does not mean that you can take a cast of a person and create a chair from it, because you need to be able to move in a chair, just like a bed”

Finn Juhl

46 SOFA 1946
BY **FINN JUHL**



EYE TABLE 1948

This eye shaped, three-legged table was originally designed to match the 46 Sofa. The shape of the table fits perfectly with the curve of the sofa, and hence creating a design unity between the two pieces.

The small table with the characteristic and organic eye shape is also a perfect complement to the Poet Sofa and fits almost any design style - particularly as a side table for a lamp, a vase of flowers or a pile of books.

The Eye Table, with the soft curves, is available in various combinations. The table is manufactured in teak, oak or walnut and comes with a tabletop in veneer or high gloss laminate in black or white.

Dette øjeformede, trebenede sofabord er oprindeligt tegnet til at matche den lille topersoners 46-sofa. Bordets form passer ind i hulningen på sofaens forkant, således at bord og sofa danner en designmæssig helhed.

Men det lille bord, med den karakteristiske øjeform, er også en perfekt ledsager til Poetsofaen og passer til ethvert interiør og enhver stilart. Bordet fungerer også fritstående til eksempelvis en lampe, en buket blomster eller en stak bøger.

Øjebordet, med de behagelige, afrundede og massive kantlister, produceres i træsorterne teak, eg eller valnød. Bordpladen fås i finér eller med højglans laminat i sort eller hvid. Bordet leveres i flere kombinationer.

PRODUCT INFO

MODEL	FJ 4850
YEAR	1948, relaunched in 2008
MATERIALS	Teak, oak, walnut Tabletop: Veneer or black/white high gloss laminate
DIMENSIONS	Size: L 90cm x W 56cm x H 50cm Weight: 10kg Cbm: 0.30m ³

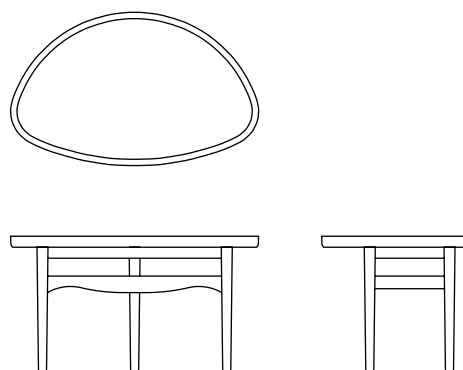







EYE TABLE 1948
BY FINN JUHL



GLOVE CABINET 1961

The Glove Cabinet, designed by Finn Juhl for his wife Hanne Wilhelm Hansen, was presented by Ludwig Pontoppidan at the Cabinetmaker's Guild Exhibition in 1961. This exhibition marked Finn Juhl's 25th anniversary and became his last exhibition of that kind.

Finn Juhl's 1961 exhibition became the focal point of strong criticism, especially from designers such as Børge Mogensen and Arne Karlsen, who were followers of the Klint School of furniture design. Their view was based on a social aesthetic functionalism, where unnecessary decoration was frowned upon.

But time has proved his critics wrong. Finn Juhl's designs indeed possess longevity. With his artistic approach to design, Finn Juhl was one of the few who mastered both functionality and delicate detail. Although women no longer wear gloves like in the 1960s, Finn Juhl's reinvention of the traditional chest of drawers still stands the test of time more than 50 years later.

This jewelry box of a glove cabinet, with its exclusive cherrywood and brass exterior combined with a daring colorful interior, seems today like an extraordinary tribute to both the past, present and the future.

Handskeskabet blev præsenteret af Ludwig Pontoppidan på Snedkerlaugets Møbeludstilling i 1961, som blev Finn Juhls 25. og sidste laugsudstilling.

I 1961 stod dansk møbelfremstilling ved en korsvej mellem de stolte møbeltraditioner fra den internationalt berømte Danish Modern-bevægelse og den uundgåelige fremtid, anført af den industrielle produktion.

Finn Juhls 1961-udstilling blev stærkt kritiseret af særligt de designere, der udsprang af den Klintske skole, og som baserede sig på en social-æstetisk funktionalisme, hvor al unødvendig dekoration var bandlyst. Men tiden har været med Finn Juhls designs, og hans fornyelse af det lille klassiske skuffemøbel tager sig stadig lige frisk ud, her mere end 50 år senere.

Handskeskabet, med sine eksklusive ydre detaljer i massiv japansk kirsebærtræ, messinghjul og sit dristige indre i klare farver, virker i dag som en bemærkelsesværdig hyldest til både fortiden, nutiden og fremtiden.

PRODUCT INFO

MODEL FJ 6100

YEAR 1961, relaunched in 2015

MATERIALS Solid Japanese cherry with a handle in wenge and drawers in a warm and cold range of colors.
Legs in burnished steel and wheels and fittings in brass.

DIMENSIONS Size: W 69.2cm x D 34.8cm x H 51.7cm
Weight: 12kg
Cbm: 0.35m³

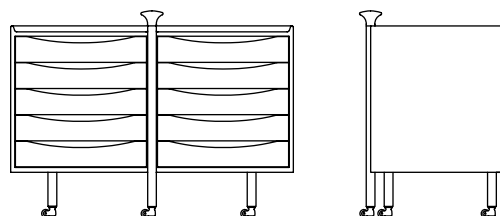





GLOVE CABINET 1961
BY **FINN JUHL**





BAKER SOFA 1951

Edgar Kaufmann Jr., a prolific art collector and director of the Industrial Design Department at the Museum of Modern Art in New York, introduced Finn Juhl to the American design circles. During a trip to Denmark, he became so fascinated by Finn Juhl's artistic take on furniture design that he invited him to the United States.

In 1949, Kaufmann Jr. wrote an article about Finn Juhl in the magazine *Interiors*, which caught the attention of Mr. Hollis Baker, a furniture manufacturer from Michigan. Hollis Baker invited Finn Juhl to design a modern furniture collection for him. These events marked the beginning of what later on became known as Danish Modern, which started an export boom for Danish design to the United States.

The sculptural Baker Sofa with its two-piece backrest became Finn Juhl's American debut.

The Baker Sofa is masterfully manufactured with a wooden frame in teak, oak or walnut. The upholstery is all handsewn in fabric or leather, with springs in the cushion, providing maximum comfort and durability. This exclusive sofa is built to please its owner for generations to come.

Den daværende kunstsamler og direktør for designafdelingen hos Museum of Modern Art i New York, Edgar Kaufmann Jr., introducerede Finn Juhl til den amerikanske designscene. Under en rejse til Danmark var han blevet så fascineret af Finn Juhls kunstneriske formsprog, at han inviterede ham til USA.

I 1949 skrev Kaufmann Jr. en artikel om Finn Juhl i magasinet *Interiors*. Artiklen medførte en henvendelse fra Mr. Hollis Baker, en møbelfabrikant i Michigan, der spurgte Finn Juhl, om han ville tegne en moderne møbelkollektion for ham. Dette blev optakten til Danish Modern og et sandt eksporteventyr for dansk design i USA.

Den skulpturelle Bakersofa, med den todelte ryg, blev det første Finn Juhl-møbel produceret af Baker Furniture. I 2001 endte samarbejdet, da Finn Juhls enke Hanne Wilhelm Hansen overlod enerettighederne til os.

Bakersofaen er mesterligt udført med et organisk formet træstel i teak, eg eller valnød. Polstringen er rent håndarbejde i stof eller læder, med springindlæg i den løse sædehynde, der giver maksimal komfort og holdbarhed. Dette eksklusive møbel er bygget til glæde for denne og fremtidige generationer.

PRODUCT INFO

MODEL FJ 5100

YEAR 1951, relaunched in 2009

MATERIALS Frame: Teak, oak, walnut
Upholstery: Fabric, leather

DIMENSIONS Size: W 195cm x D 80cm x H 98cm
Seat height: 44cm
Weight: 65kg
Cbm: 1.81m³

Fabric consumption:
Body: 2.80m
Back + Cushion: 4.25m

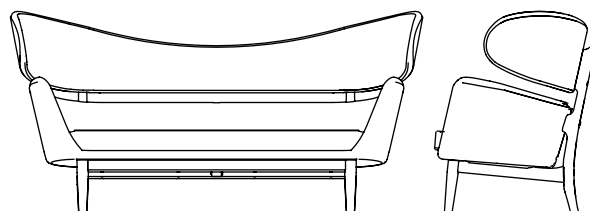





BAKER SOFA 1951
BY FINN JUHL



COCKTAIL TABLE ¹⁹⁵¹

Finn Juhl's Cocktail Table was designed for Baker Furniture in the United States to match the sculptural Baker Sofa.

The economy was booming in the US during the 1950s. Hollywood and the new upper class had made cocktail parties immensely popular and Finn Juhl was readily impressed by this newfound American extravagance, which he got to experience through his new and influential American friends.

The elegant, three-legged coffee table is a further development of his earlier eye shaped table, but as the expression goes, "everything has to be bigger in America". Despite its size, and thanks to its organic shape, with no sharp corners, the table allows for free movement around it.

The Cocktail Table is light and elegant with refined design details. The table is manufactured in teak, oak or walnut and with a tabletop in veneer or high-gloss laminate in white.

Cocktailbordet er tegnet til Baker Furniture i USA for at komplementere den skulpturelle Bakersofa.

I 1950'ernes USA bragede udviklingen afsted, og alt nyt kom derfra. Den nye overklasse gik til cocktailparties, og cocktails blev et hit - godt hjulpet af Hollywoods filmproduktioner. Finn Juhl blev meget imponeret af USA og den amerikanske ekstravagance, som han blev introduceret til gennem sine nye indflydelsesrige amerikanske venner.

Det elegante, trebenede sofabord er en videreudvikling af hans tidligere øjeformede borde, men alting i USA skal som bekendt være større. På trods af størrelsen og på grund af dets organiske form, der er helt uden skarpe hjørner, tillader det fri bevægelighed rundt om bordet.

Cocktailbordet er let og elegant med raffinerede kanter. Bordet leveres i teak, eg eller valnød med bordplade i finér eller højglans laminat i hvid.

PRODUCT INFO

MODEL	FJ 5150
YEAR	1951, relaunched in 2009
MATERIALS	Teak, oak, walnut Tabletop: Veneer or white high gloss laminate
DIMENSIONS	Size: L 160cm x W 78cm x H 50cm Weight: 15kg Cbm: 0.72m ³

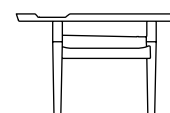
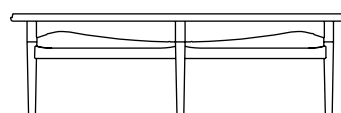
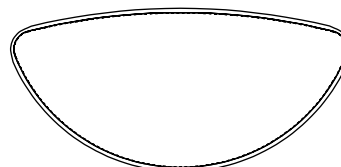







COCKTAIL TABLE 1951
BY FINN JUHL

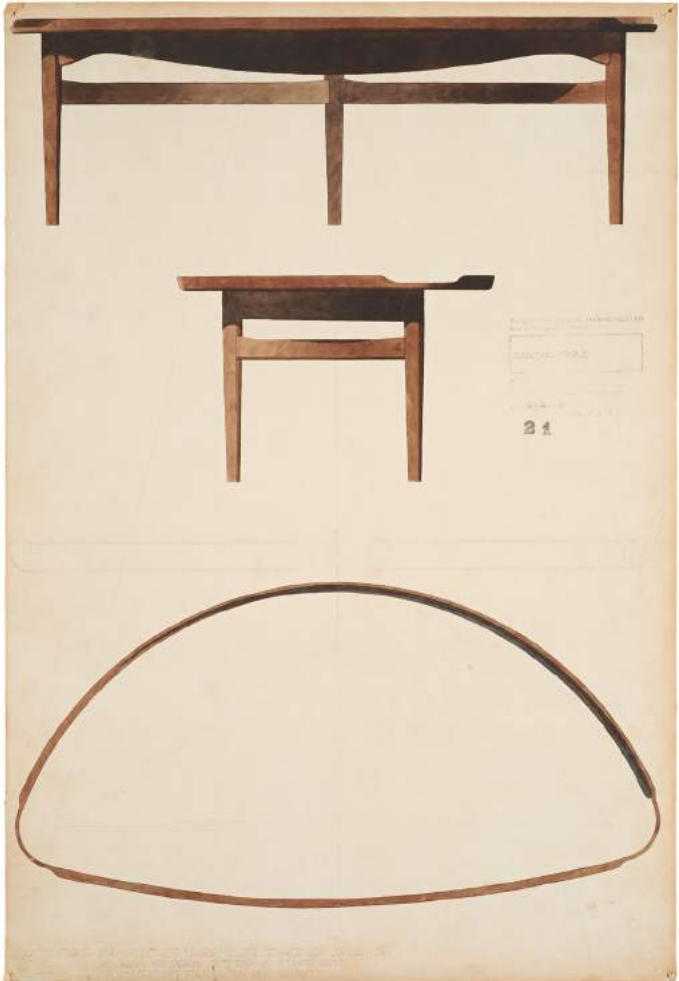

57 SOFA 1957

The sofa was exhibited for the very first time in the Tivoli Gardens in Copenhagen during 1957. However, it took more than 40 years before this extravagant design was appreciated by the general public.

The 57 Sofa was the first Finn Juhl design that we relaunched. Finn Juhl's widow, the music- and theater publisher Hanne Wilhelm Hansen, wanted this sofa to be part of an exhibition marking the 10th anniversary of Finn Juhl's passing. Therefore, she contacted us and commissioned a single issue of the sofa based on his drawings. This became the beginning of an amazing partnership with Hanne Wilhelm Hansen, who subsequently handed us the exclusive rights to manufacture Finn Juhl's furniture.

The 57 Sofa is manufactured with handsewn upholstery in fabric or leather and with springs in the seat. The legs come in burnished or stainless steel with wooden toes.

57-sofaen blev vist første gang på en udstilling i Tivoli i København i 1957. Men der skulle gå mere end 40 år, før verden åbnede øjnene for dette ekstravagante møbel.

57-sofaen var det allerførste Finn Juhl-møbel, som vi relancerede. Finn Juhls enke, musik- og teaterforlæggeren Hanne Wilhelm Hansen, ønskede, at denne sofa skulle genfremstilles til en udstilling af Finn Juhls møbler i anledning af 10-året for hans død. Derfor kontaktede hun os, og vi genskabte sofaen ud fra Finn Juhls tegningsmateriale. Dette blev starten på et fantastisk samarbejde med Hanne Wilhelm Hansen, der senere overdrog enerettighederne til at producere og relancere alle Finn Juhls møbler til os.

57-sofaen leveres med håndsyet betræk i stof eller læder samt springindlæg i sædet. Ben i bruneret eller rustfrit stål og med tæer i træ.

PRODUCT INFO

MODEL FJ 5700

YEAR 1957, relaunched in 2000

MATERIALS Legs: Stainless or burnished steel with toes in teak, oak, walnut.
Upholstery: Fabric, leather

DIMENSIONS Size: W 234cm x D 83cm x H 86cm
Seat height: 38cm
Weight: 65kg
Cbm: 1.54m³

Fabric consumption:
Body: 7.50m
Cushions: 2.50m

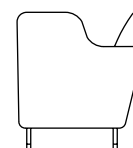
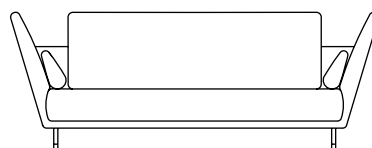
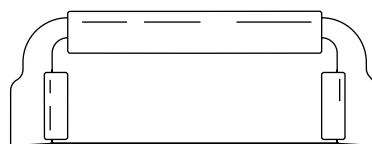



< SÆRUDSTILLING < TEMPORARY EXHIBITION





***“Creating style is different from creating fashion.
Style comes to you unknowingly while fashion is most
often the result of an exceedingly conscious process”***

Finn Juhl



57 SOFA 1957
BY **FINN JUHL**







57 SOFA 1957
BY **FINN JUHL**

ROSS COFFEE TABLE ¹⁹⁴⁸

A large share of Finn Juhl's designs was commissioned work - often as part of his business as a renowned interior designer. The Ross Coffee Table is no different. It was the result of a commission in 1948 by the well-known Danish law professor Alf Ross.

The design is extremely exciting. Its delicate steel frame, kidney-shaped top and steel inlay with a built-in vase must have been particularly unconventional and modern in its day.

The table is manufactured with a stainless steel frame and a wooden tabletop in teak or walnut with a steel inlay and a vase in steel as well.

Finn Juhl tegnede en del af sine møbler som bestillingsopgaver - ofte i forbindelse med hans omfattende indretningsvirksomhed. Således er Rossbordet et resultat af en bestilling i 1948 fra den kendte juraprofessor, Alf Ross.

Bordet er særdeles spændende. Det må have været meget utraditionelt og moderne i forhold til datidens møbelmodeller, med det spinkle stålstel og den nyreformede bordplade med stålplade og indbygget stål vase.

Bordet udføres i rustfrit stål med bordplade i teak eller valnød. Bordet fås med eller uden stålplade og stål vase.

PRODUCT INFO

MODEL	FJ 4800
YEAR	1948, relaunched in 2000
MATERIALS	Frame: Stainless steel with wooden toes Tabletop: Teak or walnut with or without a stainless steel inlay and a vase in stainless steel
DIMENSIONS	Size: L 120cm x W 30/60cm x H 58cm Weight: 12kg Cbm: 0.51m ³

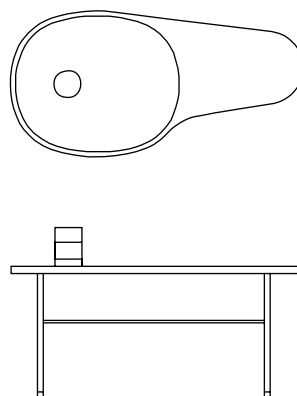



WALL SOFA 1950

Finn Juhl featured this sofa in several of his interior design projects such as Villa Aubertin in Denmark, which he designed in 1952, and in the museum Nordenfjeldske Kunstinstrimuseum in Trondheim, Norway. At the museum, he was commissioned to design a showroom with modern furniture and crafts representing a modern 1952 interior style.

Finn Juhl's extravagantly upholstered chairs and sofas from the 1940s and early 1950s are deeply original. No other furniture designer has so radically expressed the surrealistic sculptural shapes that dominated this time, as a parallel to the trends reigning on the art scene.

The Wall Sofa from 1950 is not only an excellent example of Finn Juhl's inspiration from the so-called free art of his time, but also his boundary-crossing ambition to defy gravity and create movement. The asymmetrical, excessively upholstered backrest almost floats like a cloud by René Magritte above the also levitating seat carried by an almost invisible frame. The unusually shaped back is well-suited for the human body and facilitates several comfortable ways to sit.

The sofa is upholstered by hand in fabric. The painted frame in powder coated steel tube is mounted to the wall, hence the name of the sofa.

Finn Juhl brugte denne sofa i flere af sine kendte indretninger. Blandt andet i Villa Aubertin på Lolland, som han tegnede i 1952, og i Nordenfjeldske Kunstinstrimuseum i Trondheim i Norge, hvor han fik til opgave at indrette et udstillingsrum med moderne møbler og kunsthåndværk, der repræsenterede interiørstilen i 1952.

Finn Juhls overpolstrede møbler fra 1940'erne og 1950'ernes begyndelse er dybt originale. Ingen andre designere gik så radikalt til værks og udtrykte tidens moderne skulpturelle formsprog i en møbelkunst, med en næsten fuldkommen surrealistisk sansning.

Vægsofaen fra 1950 er ikke bare et godt eksempel på Finn Juhls inspiration fra den moderne frie kunst, men også på hans lyst til at ophæve tyngdekraften og skabe bevægelse. Den asymmetriske overpolstrede ryg svæver, nærmest som en René Magritte-agtig sky, hen over det ligeledes svævende sæde, båret og bundet sammen af et næsten usynligt stel. Den særlige udformning af ryggen er tilpasset den menneskelige krop og gør det muligt at sidde eller ligge bekvemt på flere måder.

Sofaen leveres med håndsyet polsterarbejde i stof. Stellet, der består af pulverlakerede stålrør i lys grå, monteres til væggen - heraf sofaens navn.

PRODUCT INFO

MODEL FJ 5000

YEAR 1950, relaunched in 2007

MATERIALS Frame: Light grey, bended frame in powder coated steel tube
Upholstery: Fabric

DIMENSIONS Size: W 192cm x D 80cm x H 102cm
Seat height: 37cm
Weight: 60kg
Cbm: 1.81m³

Fabric consumption:
Back: 5.60m
Seat: 2.15m

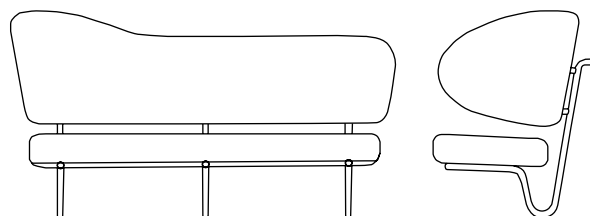



KAUFMANN TABLE 1945

The Kaufmann Table was originally designed for Finn Juhl's own home, just like many other of his iconic designs. The table is in a league of its own with an unusually refined edge profile lending itself to the illusion that the large tabletop floats, almost like a wing above the elegant frame.

Finn Juhl deliberately worked with a mix of wooden materials. A dark tabletop in walnut and a lighter frame in oak very clearly separates the carried and the carrying elements. The table's many design details have both a practical and a visual function.

The brass detail on the crossbar visually gives the table an exclusive look and at the same time protects the wood against dirt, if one would be tempted to rest one's feet on it.

The table is almost entirely crafted by hand and manufactured in oak with a veneered tabletop in teak or walnut with solid edges. Since the table was never given a name by Finn Juhl himself, we decided to dedicate it to Finn Juhl's lifelong friend, the former director of the Museum of Modern Art in New York, Edgar Kaufmann Jr., who "discovered" Finn Juhl and became instrumental in launching his international career.

Finn Juhl tegnede det store arbejdsbord til sit eget hjem på Kratvænget, som han gjorde med mange andre af sine frembringelser. Det er et bord helt i særklasse, med en ultra raffineret kantprofil, der får den ellers solide bordplade til at svæve, som en ving i luften, over det elegante bordstel.

Finn Juhl har bevidst arbejdet med forskellige træsorter. En mørk bordplade i valnød og et lyst understel i eg, for at fremhæve det bærende og det bårne. Bordets detaljerigdom er, typisk for Finn Juhl, både sanseligt og praktisk begrundet.

Den rundede messingliste, der er lagt ind i tværsargen, er både praktisk og eksklusiv, da den beskytter det lyse træ mod snavs, hvis nogen skulle få lyst til at hvile fødderne på sargen.

Bordet er perfekt udført i eg med bordplade i fineret teak eller valnød og er næsten udelukkende håndlavet. Da bordet aldrig er navngivet, har vi tilladt os at dedikere det til Finn Juhls ven, den tidligere direktør på Museum of Modern Art i New York, Edgar Kaufmann Jr., som "opdagede" Finn Juhl og var med til at sætte skub i hans internationale karriere.

PRODUCT INFO

MODEL	FJ 5045
YEAR	1945, relaunched in 2011
MATERIALS	Frame: Oak Tabletop: Teak or walnut veneer with solid edges Footrest: Brass
DIMENSIONS	Size: L 202cm x W 94cm x H 71.5cm Weight: 38kg Cbm: 0.58m ³

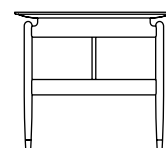
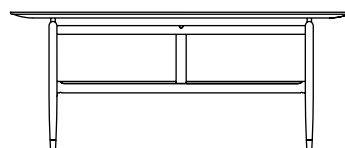
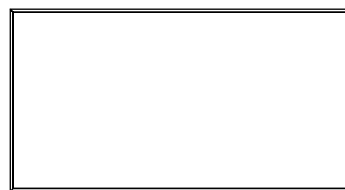



KAUFMANN TABLE 1945
BY FINN JUHL





FRANCE CHAIR ¹⁹⁵⁶

Finn Juhl rode a wave of international success during the 1950s - in part thanks to his partnership with the Danish furniture manufacturer France & Son.

C.W.F. France was an English businessman who moved to Denmark in 1936 to run a small mattress factory together with cabinetmaker Eric Daverkosen, who passed away the following year. During the 1950s, the company became extremely successful.

In 1954 France & Daverkosen accounted for 60% of all Danish furniture exports and the factory employed 350 people at its peak. In 1957, the company changed its name to France & Son, when his son James France joined the company. In 1966 the company was sold to Poul Cadovius.

The France Chair, or the FJ 136 as it is also known, was designed for the American market in the late 1950s. It was originally delivered flat-packed as knock-down furniture, which was France's business idea and the main driver for his phenomenal success on the American market. Today, however, the chair is delivered fully assembled.

The chair is available in oak, smoked oak, walnut, beech and black painted with handsewn upholstery in fabric or leather.

Finn Juhl red på en international bølge i 1950'erne - ikke mindst båret frem af samarbejdet med virksomheden France & Søn.

C.W.F. France var en engelsk forretningsmand, der kom til Danmark i 1936 for at lede en mindre madrassfabrik i Ørholm - i samarbejde med snedkermeister Eric Daverkosen, der døde året efter. I løbet af 1950'erne udviklede fabrikken, der nu var flyttet til Hillerød, sig til et sandt industrieventyr.

I 1954 stod France & Daverkosen for 60% af den samlede danske møbeleksport og beskæftigede 350 medarbejdere, da virksomheden var på sit højeste. Fabrikken skiftede navn til France & Søn i 1957, da sønnen James France kom med i firmaet. I 1966 blev virksomheden solgt til Poul Cadovius.

France Stolen, eller FJ 136, blev designet til det amerikanske marked sidst i 1950'erne og var oprindeligt leveret knock-down. Herved skulle man selv samle møblet ved dets ankomst, hvilket var hele Frances idé og forudsætningen for den store succes med eksport af danske møbler til USA. I dag leveres stolen dog samlet.

Stolen fås i eg, røget eg, valnød, bøg eller sortmalet og håndpolstret med stof eller læder.

PRODUCT INFO

MODEL	FJ 1360
YEAR	1956, relaunched in 2016
MATERIALS	Frame: Oak, black painted oak, smoked oak, beech, black painted beech, walnut Upholstery: Fabric, leather
DIMENSIONS	Size: W 80cm x D 72cm x H 81cm Seat Height: 38cm Weight: 11kg Cbm: 0.45m ³ Fabric consumption: Back + Seat: 2.0m

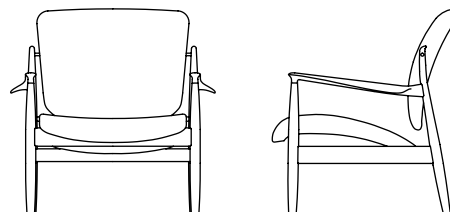
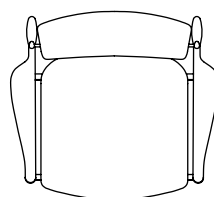





FRANCE CHAIR 1956
BY **FINN JUHL**







FRANCE CHAIR 1956
BY **FINN JUHL**



JAPAN SERIES 1953

Finn Juhl's partnership with the furniture manufacturer France & Son gave birth to a series of furniture well-suited for industrial production, while staying true to the ideals of simple designs that reigned in the 1950s.

The most famous example of this cooperation is probably the Japan Series from 1953, which consists of an armchair, a footstool, a two-seater sofa and a three-seater sofa.

The sublime simplicity of this series is a far cry from his earlier furniture designs and is inspired by traditional Japanese building techniques. The solid horizontal backrest, resting on the slightly tapered legs, is a reference to a Japanese temple door. The backrest ends in a circular recess, adding an optically refined impression with great effect. That was very typical of Finn Juhl, who famously said that deviation is in the detail.

Even with this simple construction, Finn Juhl is true to his idea of emphasizing the difference between the carried and the carrying elements by separating the backrest from the bearing frame with brackets in brass. The Japan Series is produced in teak, oak or walnut with handsewn upholstery in fabric.

PRODUCT INFO

YEAR 1953, relaunched in 2007

MATERIALS Frame: Teak, oak, walnut
Upholstery: Fabric

DIMENSIONS FJ 5300 (Stool)
Size: W 60cm x D 53cm H 35cm
Weight: 6kg
Cbm: 0.13m³
Fabric consumption: 1.00 m

FJ 5301 (Chair)
Size: W 61cm x D 70cm x H 78cm
Seat height: 35cm
Weight: 20kg
Cbm: 0.50m³
Fabric consumption: 2.00m

For firmaet France & Søn tegnede Finn Juhl en række møbler velegnet til mere industriel produktion, som indfriele tidens krav om mere enkle møbeltyper. De mest kendte af disse er nok Japanserien fra 1953, bestående af en lænestol, en skammel, en topersoners sofa og en trepersoners sofa.

Seriens sublime enkelthed og minimalistiske formsprog ligger milevidt fra hans tidligere møbler, og drager paralleller til traditionel japansk byggeskik.

Den tværliggende kraftige rygsprosse, der står på de let spidsede ben, minder om en japansk tempelport. Rygsprossen afsluttes med en hulkehl, der giver et optisk raffinement med stor virkning og er typisk for Finn Juhl, der netop sagde, at afvigelsen ligger i detaljen.

Men selv med denne enkle konstruktion fastholder Finn Juhl sin idé om at markere forskellen mellem det bærende og det bårne, ved at frigøre ryggen fra stellet med afstandsstykker i messing. Japanserien leveres i teak, eg og valnød med håndsyet betræk i stof.

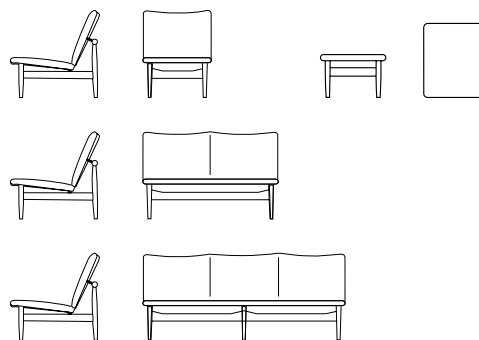

FJ 5302 (Sofa 2-seater)

Size: W 121cm x D 70cm x H 78cm

Seat height: 35cm

Weight: 40kg

Cbm: 0.90m³

Fabric consumption: 3.00m

FJ 5303 (Sofa 3-seater)

Size: W 180 cm x D 70cm x H 78cm

Seat height: 35cm

Weight: 60kg

Cbm: 1.20m³

Fabric consumption: 4.00m







JAPAN SERIES 1953
BY **FINN JUHL**

500 TABLE 1958

In similar fashion to the Japan Series, this series of coffee tables were designed by Finn Juhl for France & Son in 1958. At that time, France & Son was the leading Danish manufacturer of industrially produced furniture.

The table represents a style that became very typical for Scandinavian mid-century furniture.

The 500 Table is manufactured in solid teak, oak or walnut and is available in two sizes.

Sammen med Japan Serien er denne serie af sofaborde tegnet af Finn Juhl i 1958 for France & Søn. France & Søn var på det tidspunkt den førende danske producent af mere industrielt fremstillede møbler.

Bordet repræsenterer en stil, som blev typisk for skandinaviske møbler i midten af det 20. århundrede.

500-bordet leveres i massiv teak, eg eller valnød og fås i to størrelser.



PRODUCT INFO

YEAR 1958, relaunched in 2008

MATERIALS Teak, oak, walnut

DIMENSIONS FJ 5802
Size: L 84cm x W 78cm x H 46cm
Weight: 25kg
Cbm: 0.38m³

FJ 5803
Size: L 145cm x W 51cm x H 46cm
Weight: 30kg
Cbm: 0.43m³

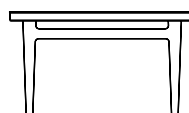
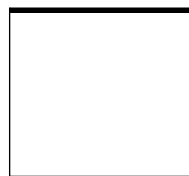
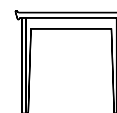
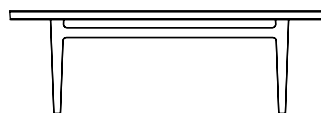
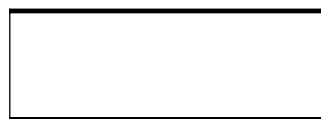



UNITED KINGDOM

45 CHAIR 1945

The 45 Chair is the definition of a true masterpiece, and has become symbolic for Finn Juhl's design genius. The chair was presented at the Copenhagen Cabinetmaker's Guild Exhibition in 1945 and has been called "the mother of all modern chairs" by the Japanese professor and chair expert Mr. Noritsugu Oda.

This chair was one of the first to break free of the current tradition for armchairs by freeing the upholstered areas from the wooden frame. With the 45 Chair, Finn Juhl created an elegant chair in this innovative style that he had been working towards for many years. The result was a clean, strong and elegant chair and a quiet revolution.

The space between the frame and the seat creates a lightness, which, combined with its organic shape and sublime detailing, creates a unique beauty. The chair is also extremely comfortable and thus appeals to all senses.

The 45 Chair is manufactured in teak, oak or walnut and upholstered with fabric or leather.

45-stolen er et mesterværk og ikonisk for Finn Juhls møbelkunst. Stolen blev første gang præsenteret på Snedkerlaugets udstilling i 1945, og er af den japanske stolesamler Mr. Noritsugu Oda blevet kaldt "alle moderne stoles moder".

Finn Juhl skabte med denne elegante lænestol et hidtil uset stoledesign, idet han adskilte det bærende stel fra den bårne krop. Resultatet blev et rent, stærkt og yderst elegant formsprog.

Mellemrummet mellem stellet og sædet skaber en lethed, som i kombination med de organiske former og sublime detaljer, tilføjer en unik skønhed og svævende elegance. Stolen appellerer til alle sanser og vækker behag for både øje og krop.

45-stolen leveres i teak, eg eller valnød og polstres med stof eller læder.

PRODUCT INFO

MODEL FJ 4500

YEAR 1945, relaunched in 2003

MATERIALS Frame: Teak, oak, walnut
Upholstery: Fabric, leather

DIMENSIONS Size: W 66.5cm x D 73cm x H 88cm
Seat Height: 42cm
Weight: 12kg
Cbm: 0.49m³

Fabric consumption:
Body: 1.75m
Cushion: 0.55m

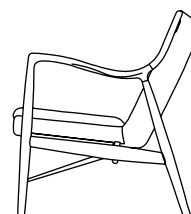
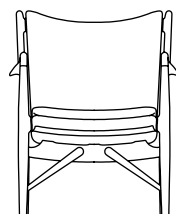
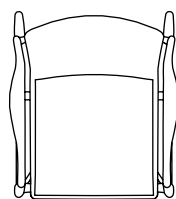





45 CHAIR 1945
BY **FINN JUHL**



46 CHAIR 1946

This chair is an example of Finn Juhl's most beautiful work. It was originally designed in 1946 for the Copenhagen Cabinetmakers' Guild Exhibition for master cabinetmaker Niels Vodder. In 1953, Finn Juhl modified the chair into a simpler, more aerodynamic version for the furniture manufacturer Bovirke. It is this later version, that we have relaunched.

In this version, Finn Juhl clearly attempted to emphasize the lightness of the chair by separating the carried and the carrying elements. Similar to the Chieftain Chair and the 45 Chair, the 46 Chair represents the very best of modern Danish furniture design. Thanks to modern technology the relaunched version is manufactured in an outstanding quality with stronger joints than the original.

The 46 Chair is manufactured in teak, oak or walnut and is upholstered with fabric or leather. The chair is available with or without armrests.

Denne stol er én af de smukkeste stole fra Finn Juhls hånd, oprindeligt tegnet for snedkermester Niels Vodder i 1946 til Snedkerlaugets udstilling. I 1953 modificerede Finn Juhl stolen i en enklere og mere aerodynamisk udgave for det daværende firma Bovirke. Det er denne udgave, som vi har valgt at relancere.

Finn Juhl har med 1953-udgaven af 46-stolen klart haft til hensigt at give stolen mere lethed ved, som på 45-stolen, at adskille det bærende fra det bårne. Ligesom 45-stolen og Høvdingestolen er 46-stolen eksponent for noget af det ypperste inden for moderne dansk møbelkunst, der stadig fremstilles i en enestående håndværksmæssig kvalitet.

46-stolen leveres i teak, eg eller valnød og med betræk i stof eller læder. Stolen fås desuden med eller uden armlæn.

PRODUCT INFO

MODEL FJ 4652 (w/o armrests)
FJ 4653 (w/ armrests)

YEAR 1946, relaunched in 2008

MATERIALS Frame: Teak, oak, walnut
Upholstery: Fabric, leather

DIMENSIONS Size: W 62cm x D 53cm x H 82cm
Seat height: 44cm
Weight: 11kg
Cbm: 0.35m³

Fabric consumption:
Back + Seat: 0.80m

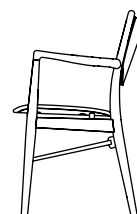
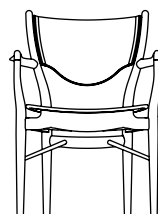
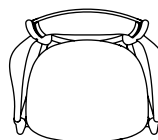
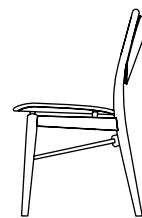
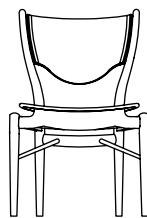
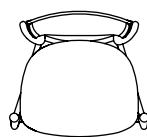





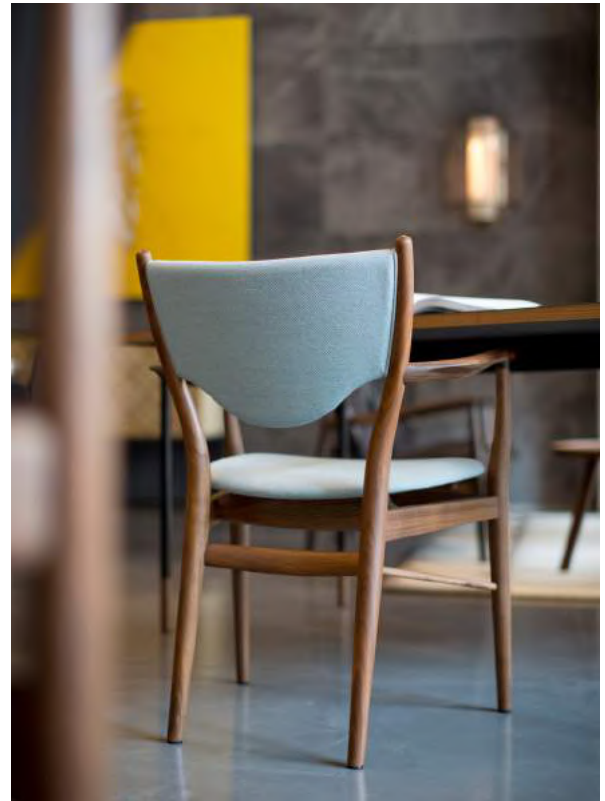

46 CHAIR 1946
BY **FINN JUHL**

108 CHAIR 1946

Finn Juhl was never boring in his expression. To this day, his designs are always unconventional and there are often exciting things going on as he defies expectations. Finn Juhl himself once said that the deviation is in the detail. This is very much the case with his 108 Chair, which on the surface looks like any ordinary dining chair. Upon closer inspection, surprising details such as angled side bars and sliding cross bars are revealed. These details add unexpected movement and dynamics to the construction.

Finn Juhl's philosophy of separating the carried and the carrying elements, thus creating space is apparent in this chair. Despite being both upholstered and very comfortable the 108 Chair manages to keep its lightness and appears beautiful from all angles.

The chair is manufactured in oak, walnut or black painted and is upholstered with fabric or leather.

Finn Juhl var aldrig kedelig i sit udtryk. Der sker altid noget spændende og uforudsigeligt i forhold til det forventede. Finn Juhl sagde selv, at der ligger en afvigelse i detaljen. Således også i 108-stolen, som ved første øjekast ligner en almindelig spisebordsstol, men hvor man ved nærmere inspektion ser, at den forventede konstruktion er tilsidesat. Stolen er med de buede og vinklede sarge og sprosser gjort dynamisk, så den får bevægelse.

Finn Juhls filosofi om at adskille det bærende fra det bårne, og skabe rum og mellemrum, er her til fulde indfriet, og giver den polstrede og komfortable stol et let og luftigt udtryk. Typisk for Finn Juhl er stolen også smuk, set fra alle vinkler.

Stolen leveres i eg, valnød eller sortmalet og polstres med stof eller læder.

PRODUCT INFO

MODEL FJ 1080

YEAR 1946, relaunched in 2008

MATERIALS Frame: Oak, walnut, black painted
Upholstery: Fabric, leather

DIMENSIONS Size: W 51cm x D 46cm x H 75cm
Seat height: 45cm
Weight: 5kg
Cbm: 0.33m³

Fabric consumption:
Back + Seat: 0.60m

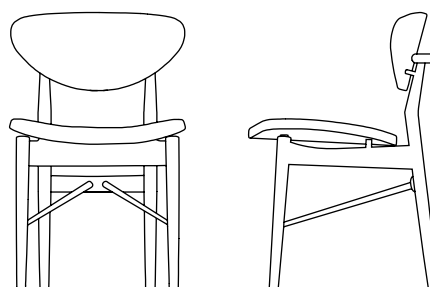





A dining room with wooden tables and chairs, decorated with dried plants and candles. The walls are made of horizontal wooden planks with small circular fasteners. Dried plants are hanging from the wall. The tables are set with glasses, napkins, and candles. A large vase with dried plants is in the foreground.

108 CHAIR 1946
BY **FINN JUHL**

109 CHAIR 1946

The 109 Chair was originally manufactured by cabinetmaker Niels Vodder, just like its close relative the 108 Chair. In this design, it is in particular the uniquely detailed armrests, that make this chair interesting and elegant.

Apart from the comfort that Finn Juhl is so famous for, the armrests are almost intimately shaped to fit a hand with its curves and angles at just the right places and with a small hollowing at the tip, which perfectly fits the plum of a thumb.

The 109 Chair is the perfect dining- or conference room chair. Its elegant and comfortable qualities make the chair a perfect fit for hotels and restaurants.

The chair is manufactured in teak, oak or walnut and with upholstery in fabric or leather.

109-stolen blev, ligesom 108-stolen, oprindeligt produceret af snedkermester Niels Vodder. Det er netop armlænene, som Finn Juhl i denne model har givet en helt unik detaljering, som gør stolen både interessant og elegant.

Ud over den, for Finn Juhl sædvanlige, gode siddekomfort, er armlænene perfekt udformet til håndens anatomi med skarphed og rundinger, hvor de behøves og med en lille hulning på spidsen, der passer nøjagtigt til tommelfingerblommen.

109-stolen passer perfekt som spisebords- eller konference stol og har helt åbenlyse kvaliteter som en elegant, komfortabel, men visuelt let stol til bl.a. hotel og restaurant.

Stolen leveres i teak, eg eller valnød og polstres med stof eller læder.

PRODUCT INFO

MODEL FJ 1090

YEAR 1946, relaunched in 2009

MATERIALS Frame: Teak, oak, walnut
Upholstery: Fabric, leather

DIMENSIONS Size: W 64cm x D 46cm x H 75cm
Seat height: 45cm
Weight: 6kg
Cbm: 0.30m³

Fabric consumption:
Back + Seat: 0.60m

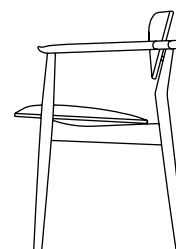
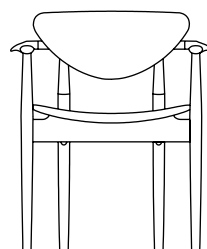
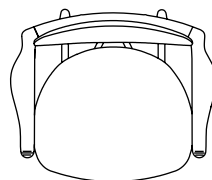





109 CHAIR 1946
BY **FINN JUHL**

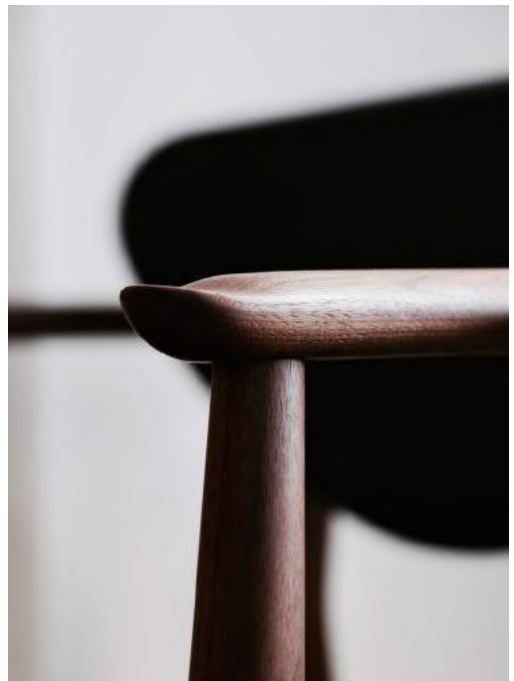





109 CHAIR 1946
BY **FINN JUHL**



CHIEFTAIN CHAIR 1949

The iconic Chieftain Chair is one of Finn Juhl's absolute masterpieces, representing the peak of his career as a furniture designer. At its introduction in 1949, the chair marked a renewal of the Danish furniture design tradition. Today, it is perceived as one of the most important exponents of the Danish Modern movement in the US during the 1950s. For this reason, Finn Juhl is often considered the father of Danish Modern.

Inspired by modern art, the Chieftain Chair with its organic shapes, liberated itself from traditional Danish furniture design and strict functionalism in both shape, construction and materials.

In 2012, the Chieftain Chair won the Danish Design Award, *Classic*. The jury said in its motivation: *"Today, the Chieftain Chair stands as an inspiration to a new generation of furniture designers and as proof that attention to quality, international calibre and a will to break away from tradition can pave the way to make a difference as a designer"*.

The Chieftain Chair and Stool are manufactured in teak or walnut and are upholstered in leather.

Høvdingestolen er et af Finn Juhls absolutte mesterværker og repræsenterer højdepunktet i hans karriere som møbeldesigner. Ved præsentationen i 1949 markerede den en fornyelse i dansk møbelkunst, og står i dag som én af de vigtigste eksponenter for Danish Modern-bevægelsens udbredelse i USA i 1950'erne. Af den grund bliver Finn Juhl, særligt internationalt, betragtet som faderfiguren for den danske designtradition.

Inspireret af samtidskunsten og med sine organiske former frigjorde Høvdingestolen sig fra den traditionsbundne danske møbeltradition og den strenge funktionalisme, med sin form, konstruktion og materialevalg.

I 2012 gik den danske pris Danish Design Award, *Classic* til Høvdingestolen. Hertil sagde juryen: *"Høvdingestolen står i dag som en inspiration for en ny generation af møbelkunstnere og som symbol på, at fokus på ultimativ kvalitet, internationalt format og vilje til at bryde tradition, kan være vejen til at gøre en forskel som designer"*.

Høvdingestolen og den matchende skammel produceres i teak eller valnød og håndpolstres med læder.

PRODUCT INFO

YEAR 1949, relaunched in 2002 (Chair)
1953, relaunched in 2015 (Stool)

MATERIALS Frame: Teak, walnut
Upholstery: Leather

DIMENSIONS FJ 4900 (Chair)
Size: W 100cm x D 88cm x H 92.5cm
Seat height: 34.5cm
Weight: 20kg
Cbm: 0.95m³

FJ 4902 (Stool)*
Size: W 60cm x D 45cm x H 38cm
Weight: 6kg
Cbm: 0.60m³

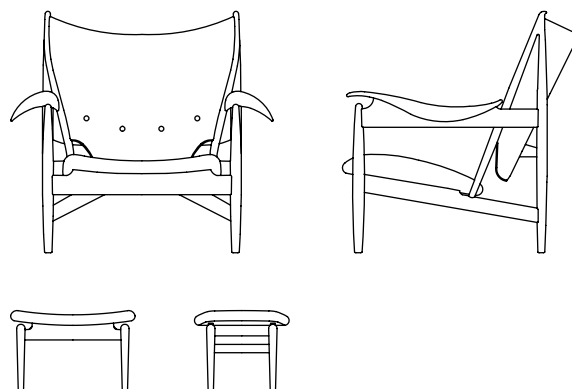

*See images of the Chieftain Stool on page 146 and 159



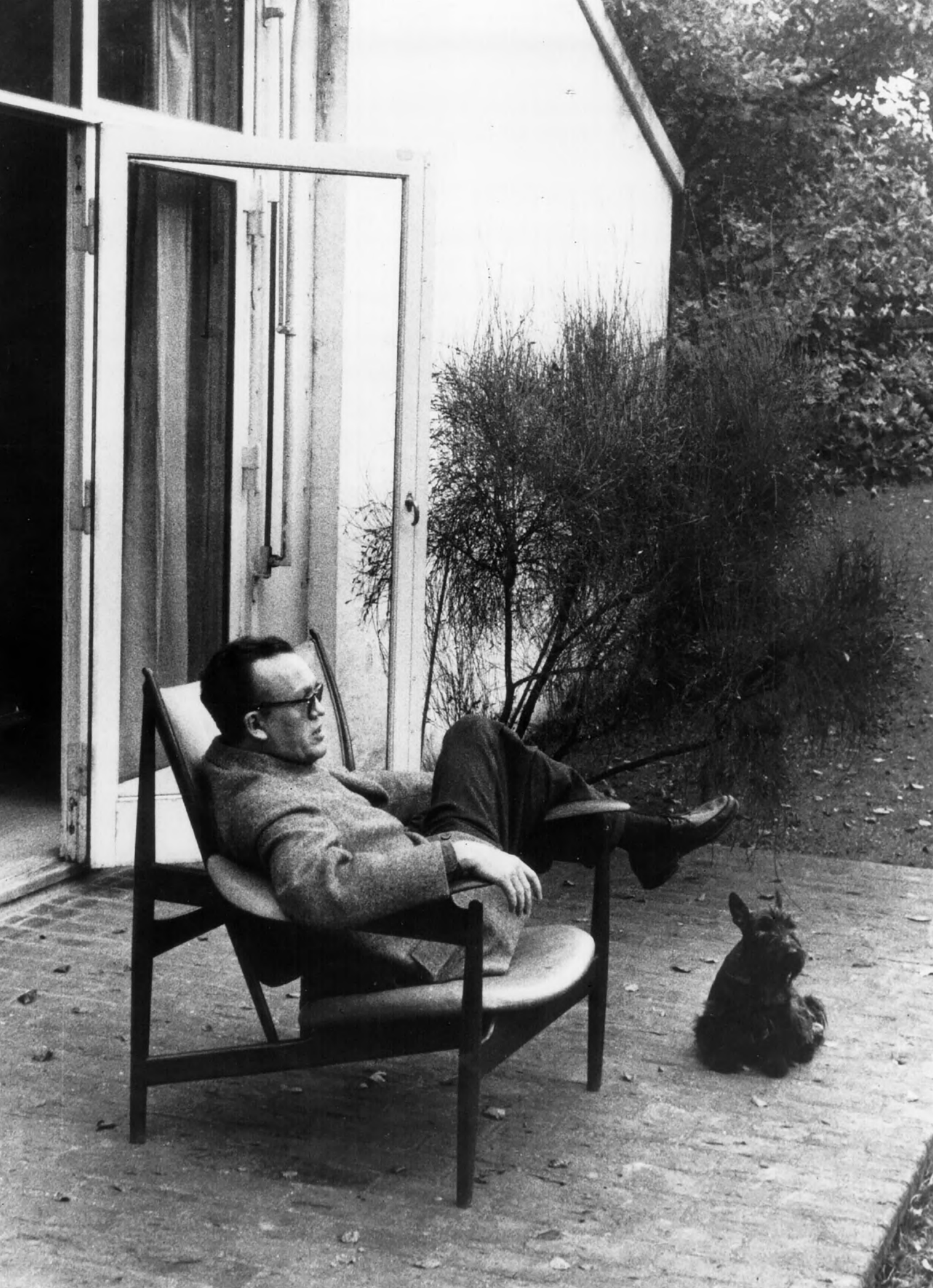



CHIEFTAIN CHAIR 1949
BY FINN JUHL







ABOUT THE CHIEFTAIN CHAIR _____

At the 1949 Guild Exhibition, Finn Juhl reached his absolute peak as a pioneering furniture designer with the imposing Chieftain Chair. The chair is probably the most well-known piece of all of his chairs and a powerful design, which not only dominates in size and extravagance but also needs a lot of space around it to do itself justice. It is in true and proper fashion a chieftain. It has, with good reason, been called an icon of Danish furniture design.

Finn Juhl was however quite modest about the development process of the chair, and did not have any expectations of its greatness. Finn Juhl said:

“I started drawing the Chieftain Chair one day in the spring of 1949. I was at home, and I started drawing a small sketch around 10 AM with just four vertical lines connected with something. By two or three o'clock in the morning I had painted it. But in reality, I don't know how long it took me to design that chair. Perhaps I had a vague idea for some time that I wanted to design something bigger. There had been so many small, handy chairs, so I probably felt like designing something a bit more pompous...”

Høvdingestolen fra 1949 anses som et af Finn Juhls absolutte mesterværker og repræsenterer et højdepunkt i hans karriere som møbeldesigner.

Om tilblivelsen af den ellers så pompøse stol med de organiske former og detaljerigdom sagde Finn Juhl beskedent:

“Jeg begyndte at tegne Høvdingestolen en eller anden dag i foråret 1949. Jeg var hjemme hos mig selv og begyndte omkring kl. 10 om morgenen at tegne en ca. 5 centimers høj skitse – bare fire lodrette streger forbundet med 'noget'. Da klokken var 2-3 om natten havde jeg malet den, og så gik den afsted. Men i virkeligheden ved jeg ikke, hvor længe, jeg har været om at lave den stol. Måske havde jeg i længere tid haft en vag idé om, at jeg gerne ville designe en større stol. Der var jo så mange små, handy stole, så jeg havde vel lyst til at lave en mere pompøs stol...”

CHIEFTAIN SOFA ¹⁹⁴⁹

Alongside the impressive Chieftain Chair, Finn Juhl and cabinetmaker Niels Vodder also introduced the Chieftain Sofa in 1949.

While the Chieftain Chair immediately went into production, there was, as far as we know, only produced one single issue of the Chieftain Sofa.

At Designmuseum Danmark in Copenhagen where the Guild Exhibitions originally took place, the sofa is still part of the museum's permanent collection of modern Danish furniture.

Today, this extraordinary piece of furniture is manufactured in a very exclusive, handcrafted version in teak or walnut. The sofa is upholstered by hand in Denmark from extra-large hides of the finest quality.

Sammen med den imponerende Høvdingestol, præsenterede Finn Juhl og snedkermester Niels Vodder også Høvdingesofaen i 1949.

Mens Høvdingestolen øjeblikkeligt kom i produktion, blev Høvdingesofaen, så vidt vi ved, kun fremstillet i et enkelt eksemplar.

På Designmuseum Danmark i København, hvor snedkerlaugsudstillingerne oprindeligt fandt sted, er dette eksemplar stadig en del af museets permanente samling af moderne dansk møbeldesign.

Dette beundringsværdige møbel fremstilles i dag i en meget eksklusiv snedkerkvalitet i træsorterne teak eller valnød. Sofaen håndpolstres i Danmark, og der anvendes kun ekstra store huder af fineste læderkvalitet.

PRODUCT INFO

MODEL FJ 4901

YEAR 1949, relaunched in 2013

MATERIALS Frame: Teak, walnut
Upholstery: Leather

DIMENSIONS Size: W 148cm x D 88cm x H 92.5cm
Seat height: 34.5cm
Weight: 28kg
Cbm: 1.51m³

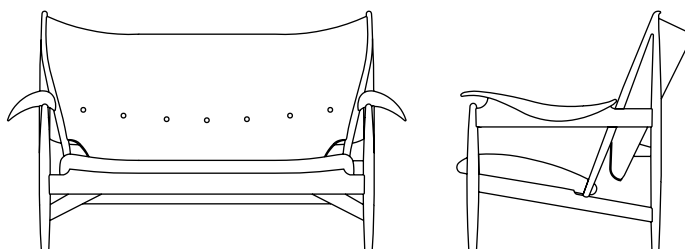





CHIEFTAIN SOFA 1949
BY **FINN JUHL**

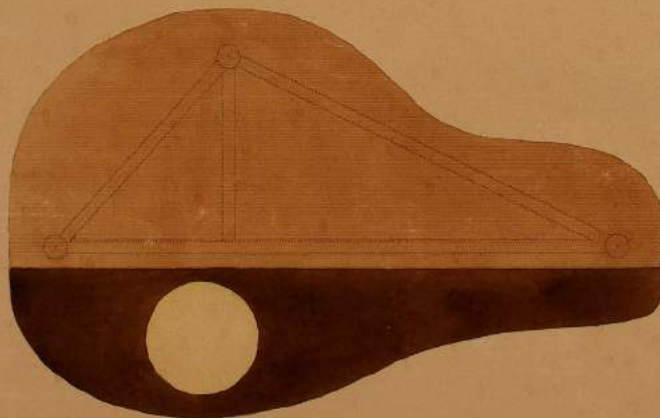
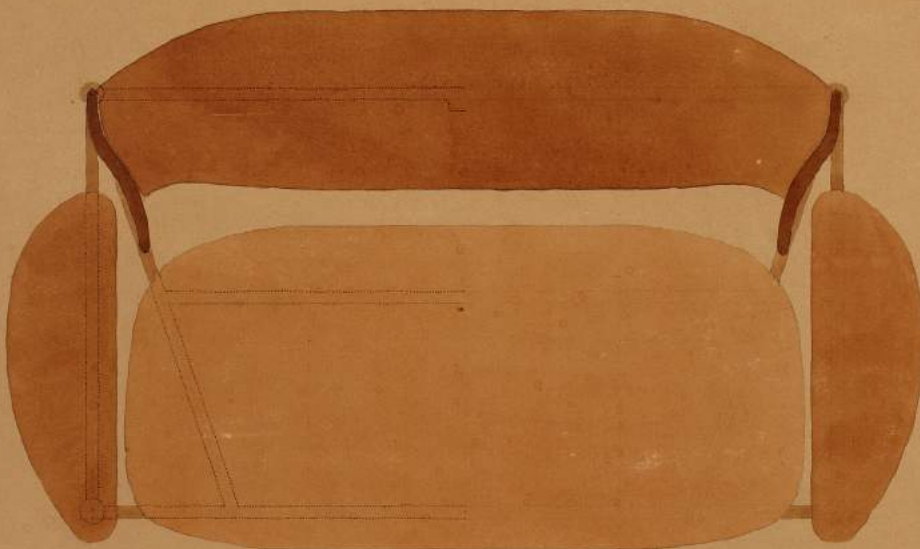

SOFABENK I 5, UDFØRES I INBUJA OG MED OKSEHUD-BETRÆK. KONSTRUKTION SOM HVILESTOLENS.
 KLAPBORD I 5, UDFØRES I TEAK OG OREGON-PINE MED BESLAG OG PLADE AF MATSLEBET MESSING.
 PLADEFORM OG BENPLACERING GIVER NEM ADGANG TIL SOFAEN. 'FRI' FORM DA INGEN FUNKTION SPIL-
 LER BINDENDE KRÆV.

*Arne Jacobsen
 Continuum*

BUTTERFLY TABLE ¹⁹⁴⁹

The Butterfly Table, designed by Finn Juhl in 1949, is a very rare table. It was practically never produced at its time of creation. The Butterfly Table was displayed alongside the iconic Chieftain Chair, Chieftain Sofa and Egyptian Chair during the famous 1949 Guild Exhibition on behalf of cabinet-maker Niels Vodder.

The three-legged and organically shaped coffee table is a very typical Finn Juhl design and stands as a testament to detailed beauty and craftsmanship.

The very unconventional table looks deceptively delicate and is today produced as the original in solid teak with a leaf in Oregon pine or entirely in walnut. Both variants come with a circular brass inlay.

Butterflybordet, som Finn Juhl tegnede i 1949, er et meget sjældent bord, som næsten aldrig har været produceret. Sammen med den ikoniske Høvdingestol og -sofa samt Egypterstolen, var Butterflybordet en del af den berømte laugsudstilling i 1949 på snedkermester Niels Vodders stand på Kunstindustrimuseet.

Det trebenede og organisk formede sofabord er typisk for Finn Juhl, med pirrende skønne detaljer og ypperligt snedkerhåndværk, der hæver bordet op i en liga helt for sig.

Bordet fås udført som oprindeligt i massivt teaktræ og med klap i Oregon pine eller helt i valnød. Begge versioner kommer med en rund messingplade indlagt i bordpladen.



PRODUCT INFO

MODEL	FJ 4920
YEAR	1949, relaunched in 2015
MATERIALS	Teak/Oregon pine, walnut
DIMENSIONS	Size: L 110cm x W 46.5/69.3cm x H 50cm Weight: 12kg Cbm: 0.40m ³

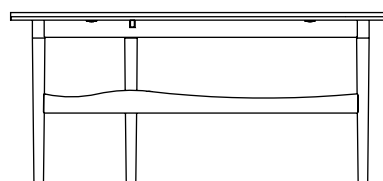
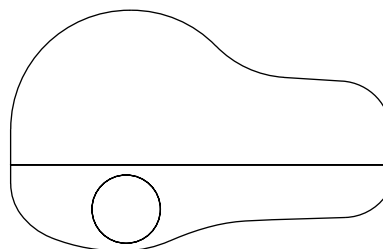

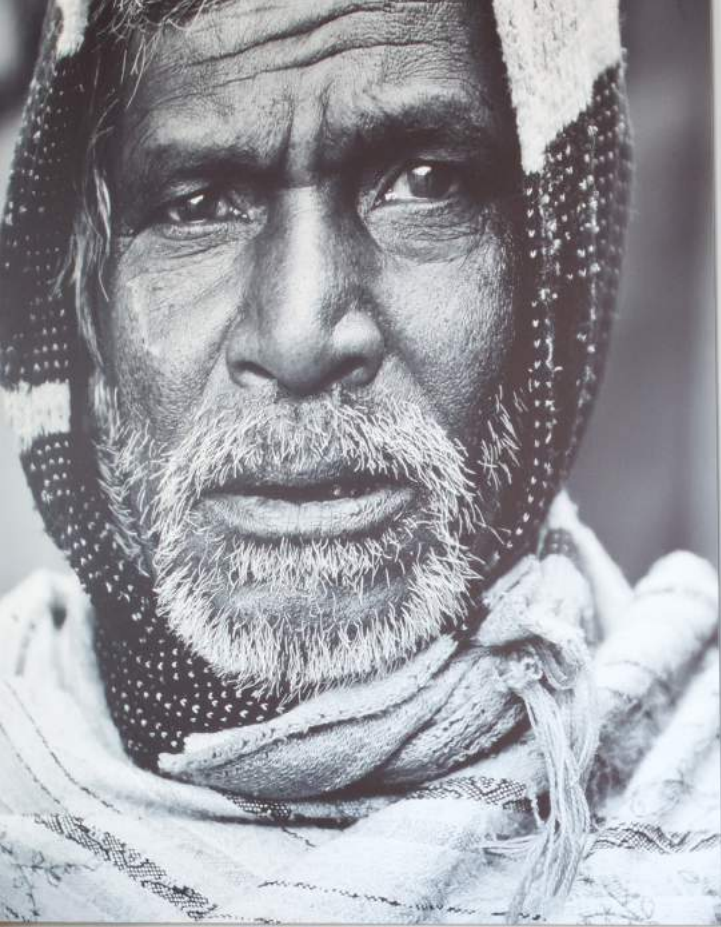

BUTTERFLY TABLE 1949
BY **FINN JUHL**



EGYPTIAN CHAIR 1949

Design critics have described Finn Juhl's Egyptian Chair as a miraculous mix of ancient Egyptian design principles, modern rhythms and aerodynamics. Both the Egyptian Chair and the Chieftain Chair are excellent examples of Finn Juhl's genius within his field and his characteristic way of achieving a "room within a room".

The chair was displayed for the first time in 1949 in Copenhagen at the Cabinetmakers' Guild Exhibition alongside the acclaimed Chieftain Chair. Riding the wave of success from this particular exhibition, Finn Juhl experienced his international breakthrough and subsequently became known as the father of the famous Danish Modern design style.

Many years later, Finn Juhl himself spoke about a visit at the Louvre Museum in Paris where he became so fascinated by an antique Egyptian chair, that he "stole" its construction when he designed his own Egyptian Chair.

Our relaunched Egyptian Chair is characterized by its unique craftsmanship. It is produced in teak, oak or walnut with upholstery in fabric or leather.

Designanmeldere har beskrevet Finn Juhls Egypterstol som en mirakuløs blanding af antikke egyptiske designprincipper, moderne rytmer og aerodynamik.

Stolen debuterede i 1949 på Snedkerlaugets udstilling sammen med den sidenhen så berømte Høvdin gestol. Med både Egypterstolen og Høvdin gestolen skaber Finn Juhl sit karakteristiske rum i rummet.

Begge stole er fremragende eksempler på Finn Juhls geni inden for sit felt. Det var på baggrund af netop denne udstilling i 1949, at Finn Juhl fik sit internationale gennembrud, der gjorde, at han sidenhen blev anerkendt som ophavsmanden til den berømte Danish Modern designstil.

Mange år senere, fortalte Finn Juhl selv om, hvordan han under et besøg på Louvre-museet i Paris blev så betaget af en antik egyptisk stol, at han "stjal" dens konstruktion, da han tegnede Egypterstolen.

Unikt håndværk karakteriserer vores relancerede Egypterstol, der leveres i teak, eg eller valnød og polstret med stof eller læder.

PRODUCT INFO

MODEL FJ 4940

YEAR 1949, relaunched in 2014

MATERIALS Frame: Teak, oak, walnut
Upholstery: Fabric, leather

DIMENSIONS Size: W 55cm x D 56cm x H 89cm
Seat height: 44.5cm
Weight: 10.5kg
Cbm: 0.47m³

Fabric consumption:
Back + Seat: 1.20m

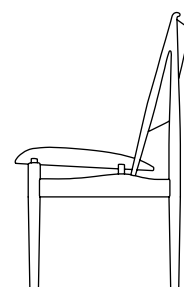
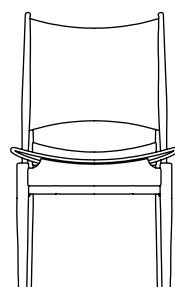
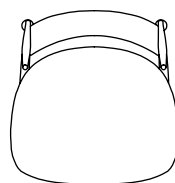







EGYPTIAN CHAIR 1949
BY **FINN JUHL**



SILVER TABLE 1948

This oval dining or conference table can be extended with two extra leaves, while the frame stays in the same position. The table was originally crafted by cabinetmaker Niels Vodder in Brazilian rosewood to be displayed at the Copenhagen Cabinetmakers' Guild Exhibition in 1948. It was subsequently made in two different wooden materials with a darker top and lighter frame.

The tabletop has 30 inlays of Sterling silver that have inspired its nickname, the Judas Table. The table is classic and simple in its shape but also exclusive and extravagant because of its fine details such as its silver inlays, that are strewn across the tabletop like a blanket of stars.

The positioning of the silver inlays is far from coincidental. They clearly indicate whether the table seats 4, 6, 8 or 10 people. With the two additional leaves the table seats 14 people.

The Silver Table is available in three variations. The first variant is in walnut as it was originally displayed. The second, comes with a teak tabletop on a frame of oak. And the third variant is entirely in oak. Furthermore, the table can be ordered with or without the silver inlays.

Sølvbordet er et ovalt spise- og konferencebord med udtræk, der forlænger bordet med to plader, men hvor understellet bliver stående. Bordet blev oprindeligt udført af snedkermester Niels Vodder i Rio-palisander til Snedkerlaugets udstilling i 1948. Siden er det ofte set i en kombination af to træsorter med mørk bordplade med lyst understel.

I bordpladen er nedfældet 30 plaketter af sterling-sølv. Af denne grund er bordet også kaldet Judas-bordet. Det er enkelt og klassisk i sin form, men også ekstravagant på grund af de skønne detaljer og ikke mindst sølvplaketterne, der er spredt ud over bordpladen som en stjernehimmel.

Placeringen af sølvplaketterne i de fire forskellige størrelser er ikke tilfældig. De opdeler bordet i kugerverter til enten 4, 6, 8 eller 10 personer. Med de to tillægsplader er der plads til 14 kugerverter.

Sølvbordet fås i tre varianter. Den første variant er med bordplade og stel i valnød, som det originalt blev vist. Den anden, er med en bordplade i teak og med stel i eg. Og den tredje variant er med bordplade og stel i eg. Bordet kan endvidere leveres med eller uden sølvplaketter.

PRODUCT INFO

MODEL	FJ 4810 (w/ silver) FJ 4820 (w/o silver)
YEAR	1948, relaunched in 2014
MATERIALS	Tabletop in veneer with or without sterling silver inlays, incl. two extension leaves. Tabletop: Teak — Frame: Oak Tabletop: Walnut — Frame: Walnut Tabletop: Oak - Frame: Oak (only available without silver inlays)
DIMENSIONS	Size: W 200/309.6cm x D 140cm x H 72.5cm Weight: 76kg Cbm: 0.65m ³

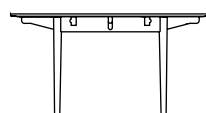
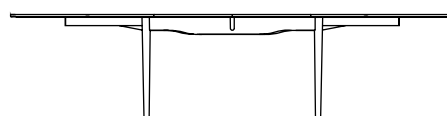
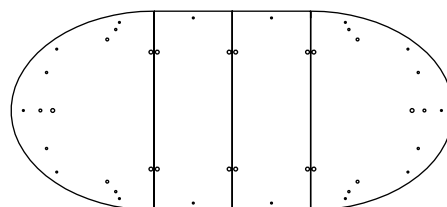







SILVER TABLE 1948
BY FINN JUHL

SIDEBOARD 1955

After Finn Juhl's rise to stardom in the American design circles around 1950, he became increasingly inspired by his American colleagues - Charles Eames in particular. Up until then, wood had predominantly been his preferred material but at this time he gradually started experimenting with steel as well.

This newfound simplicity with its straight lines became evident in his designs of desks, dining tables, coffee tables, benches, sideboards and sofas for the Danish furniture manufacturer Bovirke. These designs, with their burnished steel frames and wooden toes, were Finn Juhl's response to the criticism he had received in terms of his artsy sculptural designs and exclusivity.

Finn Juhl's simple and beautiful sideboard from 1955 combines exclusive wooden materials with the colors from Goethe's color wheel. The sideboard is manufactured with a veneered corpus in teak, oak, walnut or Oregon pine. The sliding doors are available in teak, oak, walnut or Oregon pine veneer or painted either white/yellow or white/light blue. The frame is available in burnished steel or painted black, orange or light blue. Furthermore, the sideboard comes with or without a tray unit with six drawers in a warm or cold range of colors.

Efter Finn Juhls introduktion til den amerikanske designscene omkring 1950, blev han ny-inspireret af sine amerikanske kollegers enkle design, især Charles Eames. Efter i flere år at have sværget til træet som sit fortrukne materiale til møbler, begyndte han nu at bruge mere stål.

Den nye enkelhed i Finn Juhls design med de lige linjeforløb slog igennem i hans design af skriveborde, spiseborde, sofaborde, bænke, skænke og sofaer for firmaet Bovirke på Frederiksberg. Møblerne, der blev fremstillet med malet og bruneret stålrørstel og afsluttet med trætæer, blev Finn Juhls svar på den kritik, der rejstes mod hans eksklusivitet og hans særlige udtryk, som var inspireret af den frie og skulpturelle kunst.

Finn Juhls enkle og smukke skænk fra 1955 kombinerer eksklusive træsorter med farver fra Goethes farvecirkel. Skænken leveres med fineret korpus i teak, eg, valnød eller Oregon pine og med skydelåger i finér eller malet hvid/gul eller hvid/blå. Stellet fås i bruneret stål eller malet sort, orange eller lys blå. Derudover fås skænken med eller uden seks skuffer i en varm eller kold farveskala.

PRODUCT INFO

YEAR	1955, relaunched in 2012
MATERIALS	Teak, oak, walnut, Oregon pine veneer w/ matching wooden toes Legs in burnished or painted steel in black, orange or light blue Sliding doors in white/yellow, white/light blue or veneer Tray unit w/ six drawers in a warm or cold range of colors
DIMENSIONS	FJ 5500 (w/ tray unit) Size: L 176,5cm x W 46.7cm x H 89.5cm Weight: 75kg Cbm: 1.26m ³ FJ 5507 (w/o tray unit) Size: L 176.5cm x W 46.7cm x H 89.5cm Weight: 52kg Cbm: 1.26m ³

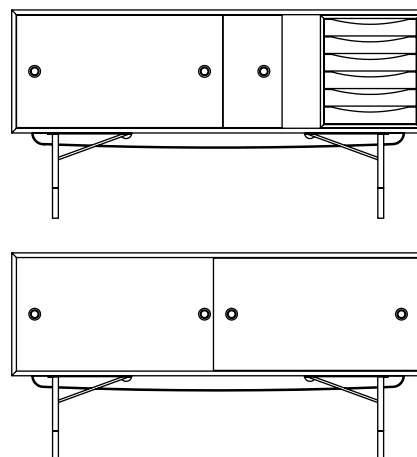







SIDEBOARD 1955
BY **FINN JUHL**

TABLE BENCH 1953

Finn Juhl experienced an international breakthrough in the USA during the early 1950s. He subsequently designed a range of furniture with steel pipe frames, inspired by the American designers he had come across.

The Table Bench was part of the range from this period and was also included in the large-scale exhibition called Design in Scandinavia. The exhibition, that was curated by Finn Juhl himself, travelled across 22 cities in North America between 1954 and 1957 and was attended by approximately 650,000 visitors. As a result of this exposure and because of its light, elegant and timeless design, the Table Bench has always been a popular piece that has achieved extremely high prices at auctions worldwide.

The Table Bench is available in teak, oak, walnut, Oregon pine or black linoleum with a frame in either burnished steel or painted black, orange or light blue. The Table Bench comes with matching wooden toes and with or without edges in matte polished brass. Furthermore, the Table Bench is available with a foldable, padded cushion in fabric or leather.

Bord-bænken blev tegnet af Finn Juhl i 1953 som en del af en serie for firmaet Bovirke. Som navnet henlyder, kan den anvendes både som et bord og som en bænke.

Finn Juhl fik i begyndelsen af 1950'erne sit internationale gennembrud i USA. Det var især interiøret til Formynderkabsrådssalen i FN's hovedkvarter i New York, som bar hans berømmelse frem, men også hans øvrige designs og en række udstillinger bidrog. Inspireret af især amerikanske designere, skabte Finn Juhl i denne periode en serie af møbler med stel af stålrør. Bord-bænken var et af disse, og indgik i vandrestillingen Design in Scandinavia, som Finn Juhl kurerede fra 1954 til 1957. Lige siden har Bord-Bænken, med sit lette, elegante og tidløse design, været et stykke eftertragtet møbelkunst, som har opnået ekstremt høje auktionspriser overalt i verden.

Bord-bænken leveres i teak, eg, valnød, Oregon pine eller med top i sort linoleum. Stellet fås i bruneret stål eller malet sort, orange eller lys blå. Den kommer desuden med matchende tæer i træ samt med eller uden mat-poleret messingkant. Det er endvidere muligt at tilkøbe en foldbar hynde i stof eller læder.

PRODUCT INFO

YEAR 1953, relaunched in 2012

MATERIALS Teak, oak, walnut, Oregon pine or black linoleum and matching wooden toes
Legs in burnished or painted steel in black, orange or light blue
With or without brass edges
With or without cushion in fabric or leather

DIMENSIONS FJ 5511 (w/ brass) FJ 5512 (w/o brass)
L 112cm x W 45cm x H 39cm
Weight: 11kg
Cbm: 0.28m³
Fabric consumption: 1.15m

FJ 5517 (w/ brass) FJ 5518 (w/o brass)
L 170cm x W 45cm x H 39cm
Weight: 13kg
Cbm: 0.42m³
Fabric consumption: 1.70m

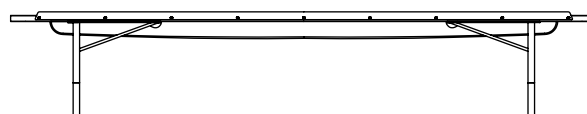
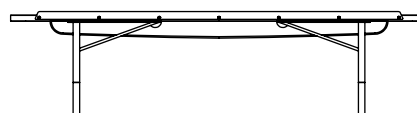
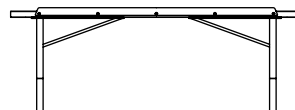

FJ 5522 (w/ brass) FJ 5523 (w/o brass)
L 225cm x W 45cm x H 39cm
Weight: 15kg
Cbm: 0.55m³
Fabric consumption: 2.25m





TABLE BENCH 1953
BY **FINN JUHL**



READING CHAIR 1953

In 1953, Finn Juhl designed this simple yet elegant dining chair for the furniture manufacturer Bovirke, which we have relaunched under the name the Reading Chair. This chair is perfectly fit for private homes, hotels, restaurants and conference facilities alike.

Finn Juhl designed the Reading Chair as both a dining room chair and as a reading chair. It is designed to be equally comfortable whether you choose to sit facing the front or the back. This might sound both odd and complicated, but thanks to Finn Juhl's genius, the result was a simple, unpretentious, yet thoroughly well-designed and visually pleasing chair.

The Reading Chair is manufactured in oak with a backrest in teak or walnut. The chair is also available in a black painted variant. The seat is upholstered with either fabric or leather.

Finn Juhl tegnede i 1953 denne enkle og elegante stol for firmaet Bovirke, som vi har relanceret under navnet Karmstolen. Stolen er særdeles egnet som spisebordsstol til private hjem såvel som til sektoren for hotel, restaurant og konference.

Karmstolen er yderst komfortabel og tillader mange siddemuligheder, hvilket er typisk for Finn Juhls møbler. Man kan endda sidde helt omvendt på stolen, således at man bekvemt hviler armene på stolens karm.

Karmstolen er udført i eg med ryg og karm i teak eller valnød. Endvidere fås en sortmalet variant af stolen. Sædet er polstret med stof eller læder.

PRODUCT INFO

MODEL	FJ 5310
YEAR	1953, relaunched in 2015
MATERIALS	Frame: Oak/teak, oak/walnut, black painted Upholstery: Fabric, leather
DIMENSIONS	Size: W 52cm x D 58cm x H 74cm Seat height: 45cm Weight: 6.5kg Cbm: 0.4m ³ Fabric consumption: Back + seat: 0.6m

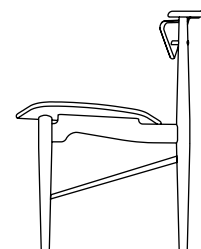
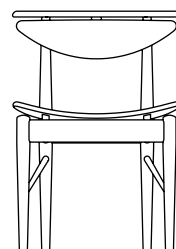
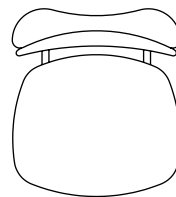





READING CHAIR 1953
BY **FINN JUHL**





NYHAVN DINING TABLE ¹⁹⁵³

Several of Finn Juhl's simple and beautiful designs from the 1950s are combined with color shades from Goethe's color wheel, e.g. the trays in the Sideboard or the Nyhavn Desk.

Another fine example from the 1950s is Finn Juhl's Nyhavn drop leaf dining table in black linoleum, teak, oak, walnut or Oregon pine veneer. Its steel legs are manufactured in black, orange or light blue with wooden toes. Special brackets allow for the leaves to be taken off or to hang vertically at both ends.

Thanks to Finn Juhl's sense of detail and functionality, this is a unique table with lots of character despite its simple appearance.

Flere af Finn Juhls enkle og smukke designs fra 1950'erne, er kombineret med farver fra Goethes farvecirkel, som f.eks. bakkerne i skænken eller Nyhavn Arbejdsbordet.

Et andet fint eksempel er Nyhavn Spisebordet med to klapper, udført i sort linoleum eller fineret teak, eg, valnød eller Oregon pine. Benstellet i stål rør leveres malet sort, orange eller lys blå med tæer i træ. Et specielt beslag tillader, at klapperne enten kan tages af eller hænge lodret ned langs begge ender.

Der er tale om et helt specielt bord, der på trods af sit enkle ydre har masser af karakter som følge af Finn Juhls sans for både detaljen og funktionaliteten.

PRODUCT INFO

MODEL FJ 5360

YEAR 1953, relaunched in 2015

MATERIALS Teak, oak, walnut, Oregon pine veneer or black linoleum with matching wooden toes
Tabletop in veneer or linoleum with solid edges
Painted frame in black, orange or light blue

DIMENSIONS Size: L 170/278cm x W 85cm x H 72.5cm
Weight: 51kg
Cbm: 1.46m³

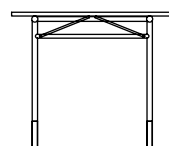







NYHAVN DINING TABLE 1953
BY FINN JUHL

NYHAVN DESK 1945

During his career, Finn Juhl designed a series of different tables with almost invisible legs in burnished or painted steel with wooden toes. In this way, he introduced an almost floating lightness into his designs.

When Finn Juhl established his first studio at the exclusive address of 33 Nyhavn in central Copenhagen in 1945, he designed a very simple desk with burnished steel legs, which came to shape his furniture design during the 1950s. When Finn Juhl moved his studio to 38 Sølvgade in 1957, these same tables were still used.

Finn Juhl varied the simple concept for different purposes and finishes. Today the table is manufactured in different sizes and available with a veneered table top in teak, oak, walnut, Oregon pine or black linoleum, with matching wooden toes on burnished steel legs. Alternatively, the legs are available in black, orange or light blue.

The table can be ordered with a tray unit with three drawers in a warm or cold range of colors. The tray unit is mounted with brackets, to further emphasize the floating lightness of the table.

I løbet af sit arbejdsliv tegnede Finn Juhl en række forskellige møbler, alle karakteriseret ved et næsten usynligt benstel, udført i bruneret eller malet stål-rør, der mod gulvet er afsluttet af en tå i træ. På denne måde tilføres bordet lethed og en nærmest svævende fornemmelse.

Da Finn Juhl etablerede sin første tegnestue på adressen Nyhavn 33 i København i 1945, tegnede han et meget enkelt arbejdsbord med brunerede stålben, der kom til at præge hans design af møbler og inventar op gennem 1950'erne. Finn Juhl varierede dette enkle koncept til mange formål og i mange udførelser.

I dag leveres bordet i flere størrelser med en bordplade i sort linoleum eller finér i teak, eg, valnød eller Oregon pine med kantlister og matchende trætæer. Benstellet fås i bruneret stål eller malet sort, orange eller lys blå.

Til bordet fås et skuffeelement med tre farvede bakker i enten en varm eller kold farveskala, der monteres med afstandsbeslag, hvilket igen giver en svævende fornemmelse.

PRODUCT INFO

YEAR

Desk: 1945, relaunched in 2009
Tray unit: 1953, relaunched in 2012

MATERIALS

Teak, oak, walnut, Oregon pine veneer or black linoleum with matching wooden toes
Tabletop in veneer or linoleum with solid edges
Frame in burnished steel or painted black, orange or light blue
Tray unit with 3 drawers in a warm or cold range of colors

DIMENSIONS

FJ 5369
Size: W 68cm L 136cm H 72,5cm
Weight: 15kg
Cbm: 0.23m³

FJ 5380
Size: L 170cm x W 85cm x H 72.5cm
Weight: 25kg
Cbm: 0.27m³

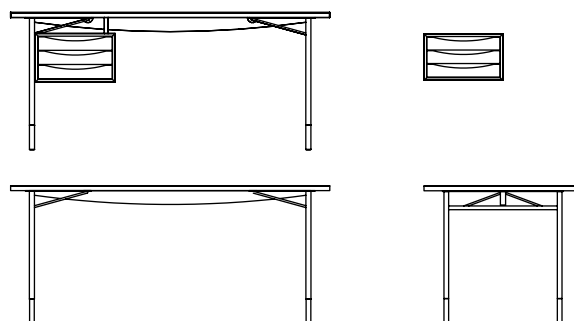

FJ 5381
Size: L 190cm x W 85cm x H 72.5cm
Weight: 30kg
Cbm: 0.28m³

FJ 5385 (Tray unit)
Size: L 43cm x W 40cm x H 26cm
Weight: 11kg
Cbm: 0.1m³







NYHAVN DESK 1945
BY **FINN JUHL**

53 SOFA 1953

During the 1950s, Finn Juhl designed a series of furniture for the company Bovirke. This series is characterized by a streamlined, industrial style. It is easily recognizable by its slender, almost invisible legs in burnished steel, as well as the use of wood and colors with Finn Juhl's sense of detail.

Finn Juhl himself used the 53 Sofa in his showroom apartment in the Bellahøj high-rise building complex as well as in many of the 33 SAS terminals he designed between 1957 and 1961.

The 53 Sofa has a simple expression. It is upholstered with fabric and comes with springs in the firm seat. The back cushions are removable and upholstered by hand in fabric as well.

Til firmaet Bovirke på Frederiksberg tegnede Finn Juhl i 1950'erne en række møbelmodeller i et stramt og mere industrielt formsprog, båret på spinkle, næsten usynlige benstel i bruneret stålrør. Der er tale om en hel serie af sammenhængende møbler i træ og farver med karakteristiske Finn Juhl-detajler.

Finn Juhl brugte selv 53-sofaen i indretningen af sin showroom-lejlighed i højhusene på Bellahøj og i mange af de 33 SAS-terminaler, som han indrettede mellem 1957 og 1961.

53-sofaen er en stram sofa med eksklusivt springindlæg i det fastpolstrede sæde og med løse ryghynder. Sofaen har håndsytet betræk i stof efter ønske.

PRODUCT INFO

YEAR 1953, relaunched in 2012

MATERIALS Legs: Burnished steel with toes in teak, oak or walnut
Upholstery: Fabric

DIMENSIONS FJ 5352 (2 seater)
Size: W 133cm x D 76cm x H 77cm
Seat height: 42cm
Weight: 38kg
Cbm: 0.83m³

Fabric consumption:
Body: 4.50m
Back + Seat: 1.50m

FJ 5353 (3 seater)
Size: W 192cm x D 76cm x H 77cm
Seat height: 42cm
Weight: 49kg
Cbm: 1.21m³

Fabric consumption:
Body: 5.60m
Back + Seat: 1.95m

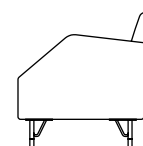
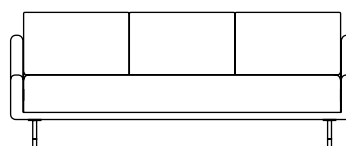
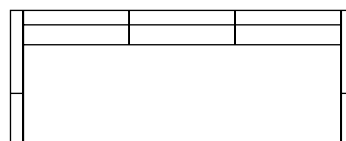
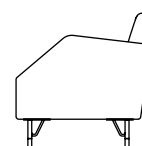
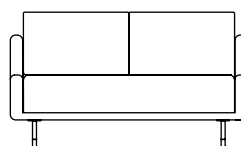
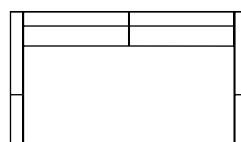



TRAY TABLE 1965

The Tray Table, designed by Finn Juhl in 1965, is a further development of his famous Turning Trays, which today are manufactured by Architectmade.

The Tray Table is in reality an elegant, slim, stainless steel frame fitted with a tray. The table works well on its own as well as in a group setting. The tray is manufactured with thin edges in teak or walnut and has a base of veneer or high gloss laminate.

Additionally, the tray can be turned and the version with high gloss laminate comes with one side in white and the other side in either black, light blue or light green.

Bakkebordet, som Finn Juhl tegnede i 1965, er en videreudvikling af hans berømte vendebakker, som i dag produceres af Architectmade.

Bakkebordet, som kan anvendes enkeltstående eller flere sammenstillede, er i realiteten et elegant tyndt trådstel i rustfri stål med en løs bakke placeret ovenpå. Bakken er vendbar og udført med tynde kanter i teak eller valnød.

Bakken fås enten fineret eller med farvet højglans laminat, der altid er hvid på den ene side, men kan vælges enten sort, lys blå eller lys grøn på den anden side.

PRODUCT INFO

MODEL	FJ 5065
YEAR	1965, relaunched in 2002
MATERIALS	Teak, walnut Tabletop: Veneer or high gloss laminate in white/black, white/light blue, white/light green Frame: Stainless steel
DIMENSIONS	Size: L 50cm x W 50cm x H 33cm Weight: 5kg Cbm: 0.13m ³

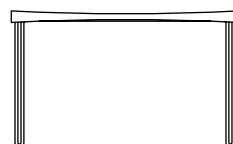
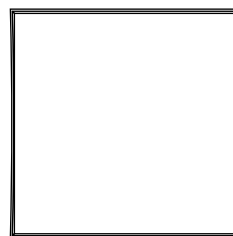



TRAY TABLE 1965
BY FINN JUHL





CIRCLE RUG 1963

During the 1960s, Finn Juhl designed a series of rug patterns for the Danish carpet manufacturer Vittrup, however, none of which were ever produced.

We have the ambition to offer a complete range of Finn Juhl designs. It was therefore a natural step to launch his rugs with their characteristic circular pattern guiding the mind towards the Swinging Sixties, which were later embraced by designers such as Verner Panton.

The rugs are produced in two sizes and come in four different color combinations - grey/black, yellow/orange, blue/navy and beige/nature. The carpets are hand-tufted in a wonderfully dense 100% looped wool.

For firmaet Vittrup Tæpper tegnede Finn Juhl i 1960'erne en række tæppemønstre, som imidlertid aldrig kom i produktion.

Vi har et ønske om at komplettere Finn Juhls kollektion. Derfor er det oplagt også at lancere tæpperne med det karakteristiske cirkelformede mønster, der får tankerne hen på 60'ernes begyndende vildskab som senere blev omfavnet af bl.a. Verner Panton.

Tæpperne fås i to størrelser og i fire farvekombinationer - grå/sort, gul/orange, blå/mørk blå og beige/natur. Tæpperne er håndtuftede i eksklusivt, kraftig loopet uld.

PRODUCT INFO

YEAR 1963, relaunched in 2015

MATERIALS Hand-tufted in a dense 100% looped wool
5000g pr. m²
Colors: Grey/black, yellow/orange, blue/navy, beige/nature

DIMENSIONS FJ 6317
Size: L 175cm x W 175cm
Weight: 15.31 kg
Square Meter: 3.06m²

FJ 6324
Size: L 245cm x W 175cm
Weight: 21.45 kg
Square Meter: 4.29 m²

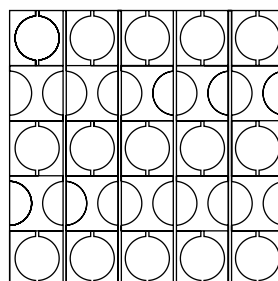
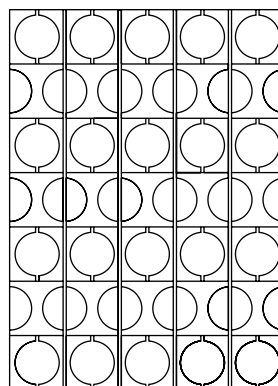







CIRCLE RUG 1963
BY **FINN JUHL**







PANEL SYSTEM 1953

When Finn Juhl designed a house or an interior, his objective was to create a so-called Gesamtkunstwerk. A humanistic-inspired work of art that makes use of all or many art forms. In his work, it translated into a philosophy where furniture and space seamlessly became one well-balanced unit.

Contrary to many of his architect colleagues, Finn Juhl worked from an inside-out approach, starting with the function of each room and how that was reflected in its interior design before he focused on the exterior.

In 1953 Finn Juhl designed a wall-mounted panel and shelving system, which complemented his interior designs in a very sophisticated manner. The panel system transformed walls into an integrated part of the overall design.

Today, Finn Juhl's Panel System is still a modern and practical solution for dynamic storage.

The flexible system allows for cupboards and shelves to be moved around independently with limitless combinations of wood, colors and even fabrics available.

Når Finn Juhl tegnede et hus eller et interiør, søgte han at skabe et såkaldt Gesamtkunstwerk. En humanistisk integration af møbler og rum i en inde-fra-og-ud tilgang, hvor alting spillede sammen i et harmonisk hele. Derfor var det også naturligt for ham at arbejde med alle rummenes funktioner.

I 1953 tegnede Finn Juhl et panel- og hyldesystem til vægmontering, som kompletterede hans interiører på en sofistikeret måde.

I dag er Finn Juhls Panelsystem stadig særdeles funktionelt og et æstetisk bud på moderne dynamisk opbevaring.

Panelsystemet aktiverede væggene til opbevaring på en integreret måde. Skabe og hylder kan frit placeres og træsorter, farver og endda stof kan kombineres efter ønske.

PRODUCT INFO

YEAR 1953, relaunched in 2013

MATERIALS Teak, walnut, oak, Oregon pine veneer or painted
Incl. mounting lists
Shelf supporter in burnished steel
Cupboard: Body teak, walnut, oak or Oregon pine veneer
Sliding doors: White/yellow, white/light blue or veneer

DIMENSIONS	FJ 5550 (Start panel)	W 78/80cm x D 4cm x H 200cm
	FJ 5551 (Running panel)	W 78/79cm x D 4cm x H 200cm
	FJ 5552 (Endlists)	W 2.8/5.6cm x D 4cm x H 200cm
	FJ 5553 (Shelf 22 cm)	W 78cm x D 22cm x H 1.9cm
	FJ 5554 (Shelf 28cm)	W 78cm x D 28cm x H 1.9cm
	FJ 5555 (Shelf 45cm)	W 78cm x D 45cm x H 1.9cm
	FJ 5556 (Cupboard)	W 157cm x D 45cm x H 30.7cm
	FJ 5557 (Bookend)	W 1cm x D 25.3cm x H 6cm

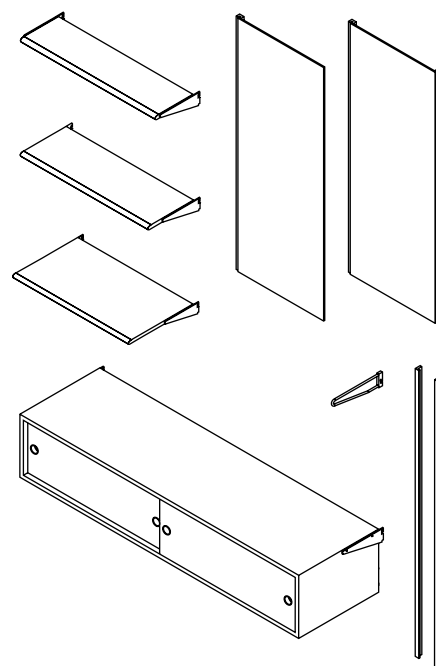



PANEL SYSTEM 1953
BY FINN JUHL







PANEL SYSTEM 1953
BY FINN JUHL



44 CHAIR 1944

Similar to other pioneers of modernism, Finn Juhl started from scratch when he designed his furniture. His first step was to analyze how the chair's different components would carry the human body. As opposed to his design colleagues, who worked with streamlined, scaffolding-like constructions, Finn Juhl found that furniture needed a comfortable humanlike liberation.

With the 44 Chair, Finn Juhl transformed the naked wooden construction into an organic shape, which prompted the nickname the Bone Chair. Eventually this chair became Finn Juhl's personal favourite. Here, the strength of the material is used to its extreme potential. In this way, his construction mimics nature, where mass is also greatest wherever strength is needed. Cabinetmaker Niels Vodder introduced the 44 Chair at the Copenhagen Cabinetmakers' Guild Exhibition in 1944, but subsequently only produced twelve in Cuban mahogany.

The 44 Chair is a very delicate piece of furniture, which is not in regular production today, but we have produced limited series from time to time for special occasions.

På linje med andre af modernismens pionerer startede Finn Juhl fra bunden, når han tegnede sine møbler. Han startede med at analysere, hvordan stolens forskellige komponenter skulle bære menneskekroppen. Men modsat sine samtids design-kolleger, med deres strømlinede stilladsagtige konstruktioner, fandt Finn Juhl, at møbler skulle have en behagende menneskelig frigjorthed.

Med 44-stolen omformede Finn Juhl den nøgne trækonstruktion til en organisk form, der også kaldes Knoglestolen, og som blev Finn Juhls eget favoritmøbel. Her er materialets styrke udnyttet til det maksimale. Ligesom i naturens egne konstruktioner, hvor massen er størst, der hvor styrken behøves. Snedkermester Niels Vodder præsenterede 44-stolen på Snedkerlaugets årlige udstilling i 1944, men håndlavede i alt kun 12 stole i Cuba-mahogni.

Den eksklusive 44-stol er heller ikke i løbende produktion i dag, men vi har, til specielle anledninger, fremstillet stolen i begrænsede serier.

PRODUCT INFO

MODEL	FJ 4400
YEAR	1944, relaunched 2011
MATERIALS	Frame: Teak, walnut Upholstery: Fabric, leather
DIMENSIONS	Size: W 51cm x D 46cm x H 75cm Seat height: 45cm Weight: 6kg Cbm: 0.3m ³

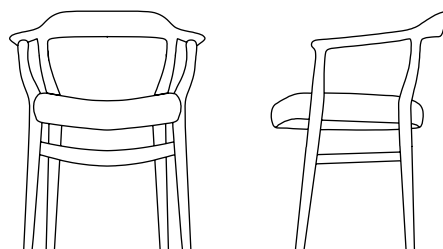



FJ 64 CHAIR 1964

In 1964, Finn Juhl designed a light, elegant and stackable chair in polyamide. The chair is significantly different from most of Finn Juhl's other designs, both in shape and materials, and emphasizes that Finn Juhl was courageous, versatile and ahead of his time.

The chair, however, never went into production and was since forgotten in the archives but as Finn Juhl once said: *"One should not despair over the fact that some of the developments one has hoped for were never produced but only became a beginning. Perhaps they will be revived some day in the future if necessary or reasonable, when the time is ripe"*.

We have decided to launch the chair, because we believe that the time is now right. The FJ 64 Chair is suitable for private homes, as well as for projects, where the light expression and durable materials fit perfectly into restaurants, the modern business, in canteens or for flexible use elsewhere.

Similar to many of Finn Juhl's other models, FJ 64 is named after the year in which it was designed.

The shell of the chair is cast in polyamide reinforced with glass fiber. The legs are manufactured in slim, painted steel pipes in black, orange, light blue or light grey. Towards the floor, the legs are completed with wooden toes in teak, oak or walnut.

Finn Juhl designede i 1964 en let, elegant og stabil stol i polyamid. Stolen er markant anderledes end mange af Finn Juhls andre møbler, både i form og materialer, og understreger at Finn Juhl var modig, alsidig og forud for sin tid.

Stolen kom dog aldrig i produktion og blev siden glemt i arkiverne, men som Finn Juhl selv sagde: *"Man skal ikke være så fortvivlet over, at de udviklinger man af og til har ønsket sig, at de ikke er blevet til noget, men kun er blevet til en begyndelse. De bliver måske taget op en anden gang, hvis det er nødvendigt, og hvis det er rimeligt, og hvis tiden er moden"*.

Vi tror på, at tiden nu endelig er rigtig. FJ 64-stolen egner sig både til det private hjem, men i høj grad også til projekter, hvor dens lette udtryk og solide form passer perfekt ind i f.eks. restauranter, den moderne virksomhed, som kantinstol eller til fleksibelt brug på kontoret.

Som mange af Finn Juhls andre møbler er FJ 64-stolen opkaldt efter året, hvori den blev tegnet.

Stoleskallen er støbt i polyamid og forstærket med glasfiber. Benene er fremstillet i tynde malede stål-rør i enten sort, orange, lys blå eller lys grå. Mod gulvet, afsluttes stolens ben med træ-tæer i teak, eg eller valnød.

PRODUCT INFO

MODEL FJ 6400

YEAR 1964, relaunched in 2017

MATERIALS Polyamide shell and painted legs in black, orange, light blue or light grey with wooden toes in teak, oak or walnut.

DIMENSIONS Size: W 63cm x D 40cm x H 77.5cm
Seat height: 45cm
Weight: 7kg
Cbm: 0.25m³

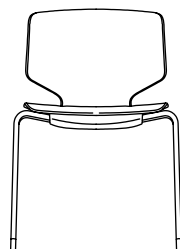
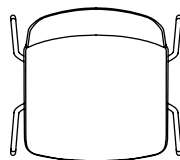







FJ 64 CHAIR 1964
BY **FINN JUHL**

MODERN ART CHAIR 1948

In 1948, the Museum of Modern Art hosted a design competition for chairs that should be ready for industrial production and retailed at low prices. This was not exactly Finn Juhl's area of expertise as he had become famous for his incredibly elegant and detailed handcrafted furniture. Nevertheless, Finn Juhl decided to submit his entry. This decision may have been based on the fact that Finn Juhl had met and established what turned out to be a life-long friendship with Edgar Kaufmann Jr., who, at the time, was the director of the Industrial Design Department at MoMA. It was also Edgar Kaufmann Jr. who introduced Finn Juhl to the American design industry.

The result of Finn Juhl's entry for the competition, was a beautiful and sculptural armchair in polyamide. Unfortunately, Finn Juhl did not win the competition. The winner, however, was Charles and Ray Eames with their famous plastic chair, which has since been produced by the millions.

The Modern Art Chair has never before been produced, but when it comes to Finn Juhl nothing is ever too late.

We have named it Modern Art Chair, as a tribute to Edgar Kaufmann Jr. and MoMA. The shell of the chair is cast in polyamide and is supported by painted steel legs in black, orange, light blue or light grey with wooden toes. The chair is complemented by a reversible, upholstered seat cushion. The chair is well suited for indoor and outdoor use alike.

I 1948 udskrev Museum of Modern Art en konkurrence om at designe en stol, der skulle kunne massefremstilles industrielt og sælges til en lav pris. Det var ikke ligefrem Finn Juhls gebet, da han var blevet kendt for sine elegante og detaljerede snedkermøbler. Men Finn Juhl besluttede alligevel at deltage. Det skyldtes måske, at Finn Juhl havde mødt Edgar Kaufmann Jr., som var leder af designafdelingen på netop MoMA. Mødet med Edgar Kaufmann Jr., blev ikke alene begyndelsen på et livslangt venskab mellem de to, men Kaufmann introducerede også Finn Juhl for den amerikanske designscene.

Finn Juhls bidrag til konkurrencen blev en smuk skulpturel armstol i polyamid. Desværre vandt Finn Juhl ikke konkurrencen. Det gjorde derimod Charles og Ray Eames' berømte stol, som sidenhen er blevet produceret i millionvis.

Modern Art Chair har aldrig før set dagens lys, men når det kommer til Finn Juhl, er intet for sent. Til sammenligning var Finn Juhls ikoniske Pelikanstol glemt i 61 år, før vi valgte at relancere den i 2001.

Vi har valgt at kalde stolen Modern Art Chair, som en hyldest til Edgar Kaufmann Jr. og MoMA. Stolen er støbt i polyamid med malede stålrør i sort, orange, lys blå, eller lys grå og med tæer i træ. Desuden har stolen en polstret vendbar sædehynde – præcis som den oprindeligt var tænkt. Stolen er lige egnet til brug inde såvel som ude.

PRODUCT INFO

MODEL FJ 4848

YEAR 1948, relaunched in 2017

MATERIALS Polyamide shell and painted frame in black, orange, light blue or light grey with wooden toes in oak, walnut or teak

DIMENSIONS Size: W 70.5cm x D 59.5cm x H 77cm
Seat height: 46cm
Fabric consumption: 0.6m
Weight: 10kg
Cbm: 0.35m³

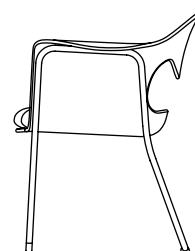
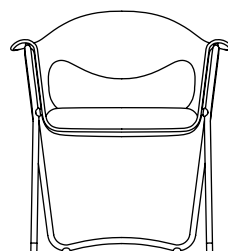
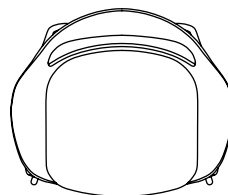





MODERN ART CHAIR 1948
BY FINN JUHL





HOUSE OF FINN JUHL
HOTEL HAKUBA





houseoffinnjuhlhakuba.com

Photo Credits - Photographers & Locations

Photographer Anders Schønnemann, Stylist Gitte Kjær (P. 104 + 107 + 115 + 137)

Photographer Andreas Weiss (P. 62 + 63 + 111 + 146 + 147)

Photographer Mikkel Kallehauge (P. 61 + 64 + 65)

ANDERSEN-ANDERSEN Showroom, Copenhagen (P. 144 + 145)

File Under Pop Showroom, Copenhagen (P. 119 + 156 + 157)

Restaurant Barr, Copenhagen (P. 82 + 83)

Restaurant Centrale, Beirut (P. 88 + 89)

Restaurant Palægade, Copenhagen (P. 120)

E

S

I

G

N

E



AN EXHIBITION
OF HOME FURNISHINGS
SELECTED BY
MUSEUM OF MODERN ART
NEW YORK
FOR
THE MERCHANDISE MART
CHICAGO

HOUSE
AND
GARDEN
COLOR
SHOW

furniture

House of Finn Juhl is part of Onecollection

HQ

Onecollection A/S
Vesterled 19
DK-6950 Ringkøbing
Tel: +45 70 27 71 01
info@finnjuhl.com
www.finnjuhl.com

SHOWROOMS

House of Finn Juhl / Galleri Feldt
Showroom and concept store
Nordre Toldbod 25
DK-1259 København K
Tel: +45 33 91 11 00
mail@finnjuhl-copenhagen.dk
www.finnjuhl-copenhagen.dk

House of Finn Juhl
Showroom and office
Frederiksgade 1
DK-1265 København K

House of Finn Juhl / Onecollection
Showroom
Østergade 11
DK-6950 Ringkøbing

Catalogue designed by Morten Duemose
www.mortenduemose.com



