

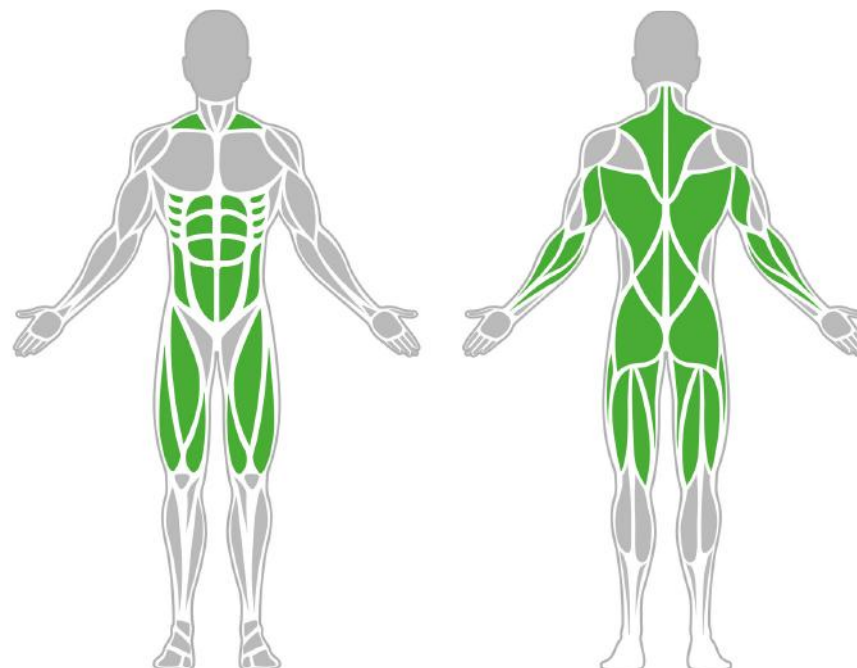

Muscle Groups Focus



Ab & Back Trainer 1900

The back muscle trainer is, as the name suggests, designed to develop the muscles of the back, while the abdominal muscle trainer does the opposite, working the muscles of the abdomen. Together, the two elements complement each other to effectively strengthen the core muscles.

Attributes

Product code	1-1-040
Certificate	EN 16630, ASTM F3101
Age group	14 + years
Capacity	2 people
Max. weight load	218.26 lbs
Type	Fitness
Difficulty level	Easy

Side View

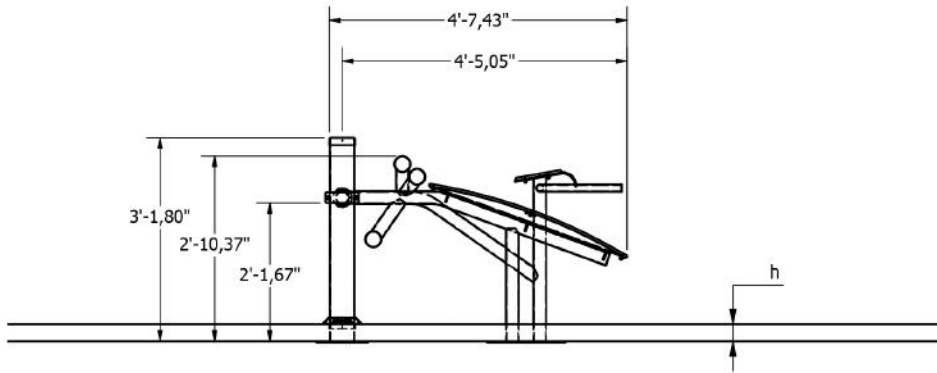

Plan View

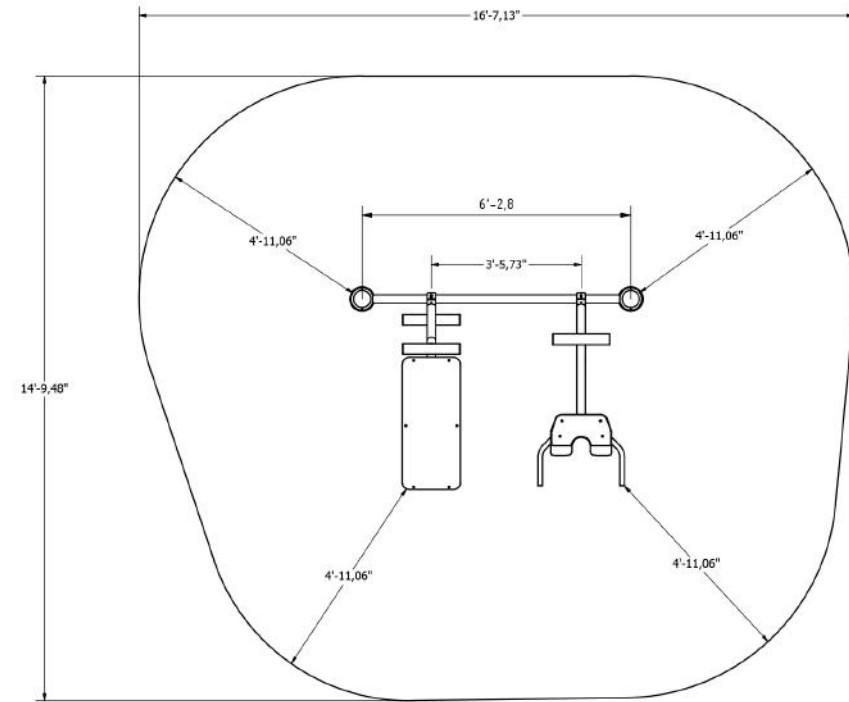

Installation information

Number of installers (concrete)	At least 2 people
Total installation time (concrete)	60-120 min.
Number of installers (equipment)	At least 2 people
Total installation time (equipment)	30-60 min.
Excavation volume	28,25 ft ³
Concrete volume	28,25 ft ³
Size of the base structure	4pc 19.69 x 19.69 x 31.5 „
Anchoring options	In-ground or surface
In combined structures, the volume of concrete required varies.	

Technical specification

Safety surface area	Around 4.92 ft radius
Net weight	167.55 lbs
Material	S235
Critic fall height	31.5"
Color options	

For more color options, discuss with your sales representative.

Warranty

Structure	25 years
Steel	15 years
Paint	2 years
Plastic	5-10 years
Rubber	1-3 years
Moving parts	2 years
Detailed information in the warranty document	

Material specification

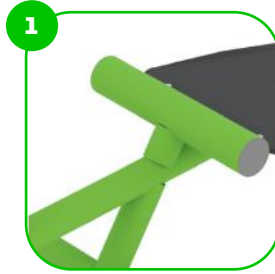

The element is made of high quality S235 steel, which has been cleaned via sandblasting. A corrosion resistant powder coating finish is then applied. Also available with galvanized surface for even greater protection and longevity!

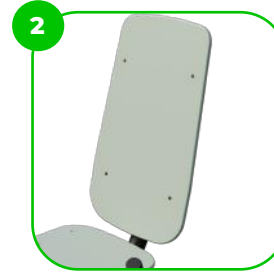

The seats and backrests are made of strong HDPE material. Which is fully heat, moisture and UV resistant.



The connecting elements are fastened with vandal-proof stainless steel screws and nuts.



The ends of the bars and posts are sealed with injection-moulded plastic caps.

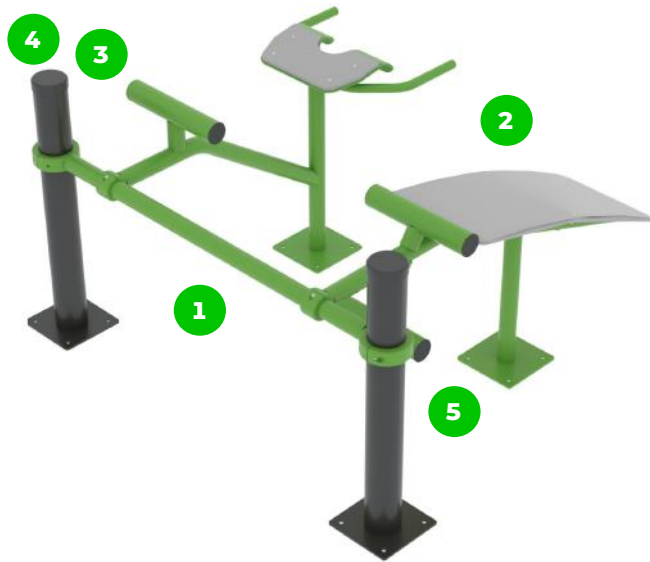

The clamp system allows for easy assembly and extreme stability.

BESTSTRONG

 [bestrongworld](#)  [bestrongworld](#)  [usa.bestrong.com](#)  [usa@bestrong.com](#)

