

# BESTRONG

 bestrongworld  bestrongworld  usa.bestrong.com  usa@bestrong.com

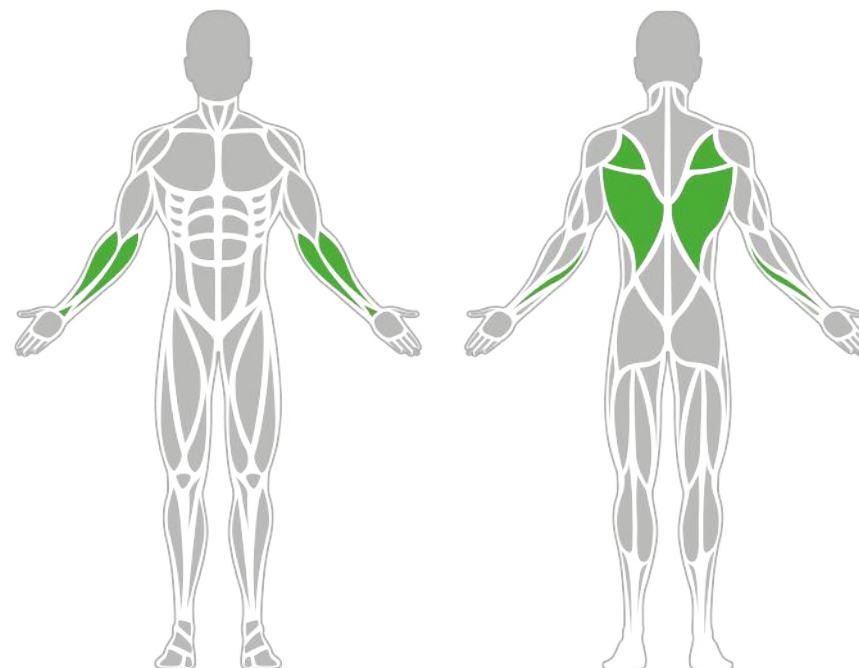

## Muscle Groups Focus



### Accessible Lateral Pull-Down

The BESTRONG Accessible Lateral Pull-Down is specially designed for users with limited mobility, helping to strengthen the muscles of the back shoulder girdle, latissimus dorsi, and trapezius. Equipped with two 44 lbs weight plates, it provides ample resistance for a safe and efficient workout. The machine's ergonomic design ensures users can perform their exercises comfortably and safely, promoting long-term health and increased physical activity.

### Attributes

|                  |                      |
|------------------|----------------------|
| Product code     | 1-1-332              |
| Certificate      | EN 16630, ASTM F3101 |
| Age group        | 14 + years           |
| Capacity         | 1 person             |
| Max. weight load | 286.60 lbs           |
| Type             | Accessible           |
| Difficulty level | Medium               |

## Side View

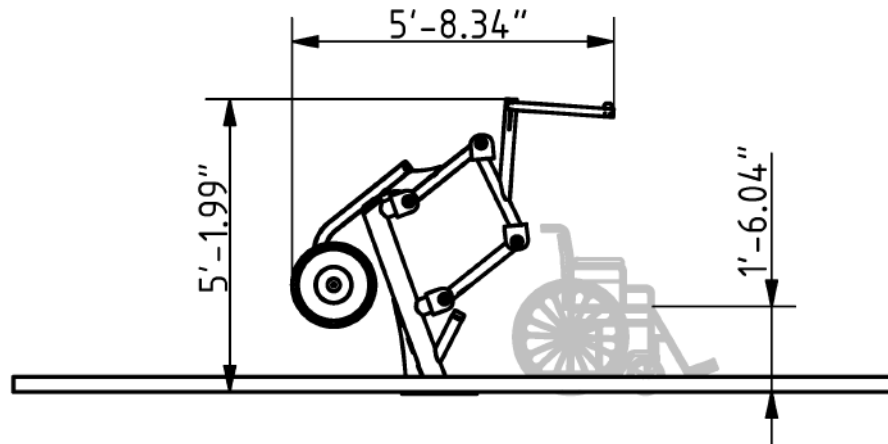

## Plan View

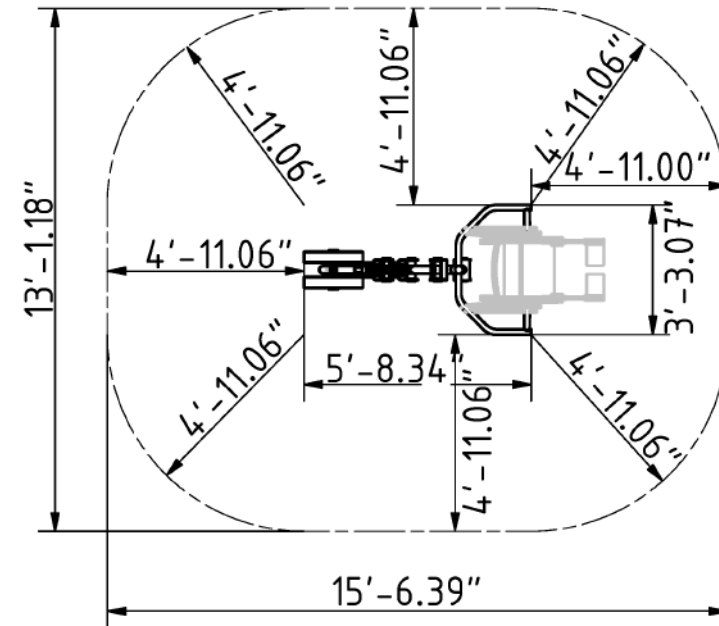

## Installation information

|   |                       |
|---|-----------------------|
| Number of installers (concrete)                                 | At least 2 people     |
| Total installation time (concrete)                              | 80-140 min.           |
| Number of installers (equipment)                                | At least 2 people     |
| Total installation time (equipment)                             | 60 min.               |
| Excavation volume   | 24.72 ft <sup>3</sup> |
| Concrete volume   | 18.08 ft <sup>3</sup> |
| Size of the base structure                                      | 31.5 x 31.5 x 31.5"   |
| Anchoring options   | Surface mounted       |
| In combined structures, the volume of concrete required varies. |                       |

## Technical specification

|   |   |
|---|---|
| Safety surface area   | Around 4.92 ft radius   |
| Net weight  | 227.08 lbs  |
| Material  | S235,S355,KO33,HDPE   |
| Critic fall height  | 18.11"  |
| Color options   |  |
| For more color options, discuss with your sales representative. |   |

## Warranty

|   |             |
|---|-------------|
| Structure                                     | 25-15 years |
| Steel   | 5-10 years  |
| Paint   | 2 years     |
| Plastic                                       | 5-10 years  |
| Rubber  | 1-3 years   |
| Moving parts                                  | 2 years     |
| Detailed information in the warranty document |             |

# Material specification

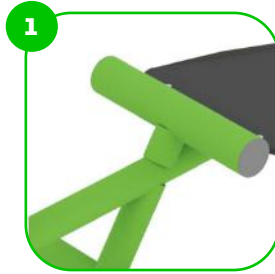

The element is made of high quality S235 steel, which has been cleaned via sandblasting. A corrosion resistant powder coating finish is then applied. Also available with galvanized surface for even greater protection and longevity!



The bumpers of the devices are made of durable rubber material.



Resistance is achieved by the fixed weight plates on the device. Made of high quality SBR material, which guarantees outstanding durability and long life.

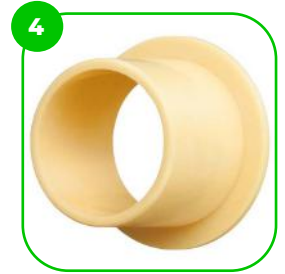

The device is fitted with composite bearings that are weather-resistant. The bearing does not require regular maintenance.



At the end of the arms, the handle is rubber-coated for a more comfortable and secure grip.

# BESTRONG

bestrongworld bestrongworld usa.bestrong.com usa@bestrong.com

