

Fast assembly for all applications:
Sensys and Intermat hinge systems



Beautiful. And beautifully quiet: Sensys



Sensys opens the door to new markets for you

Sensys hinges from Hettich are the heart of good doors. Unbeatable solutions for any furniture range with clever mounting and adjustment options. The integrated soft-closing function provides even greater convenience in closing hinged doors.



Four good reasons for Sensys

- 1. Excellent Silent System performances:**
Its outstanding performance saves a hinge on many larger type doors.
- 2. Whether in cool rooms or at high ambient temperature:**
The integrated Silent System never fails.
- 3. Closes almost on its own:**
The wide automatic closing angle of 35° lets doors close gently and reliably.
- 4. Put the final touch to your furniture design:**
Award winning Sensys design perfectly complements furniture.

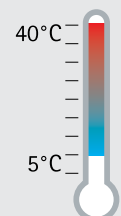

Hettich - a family owned company

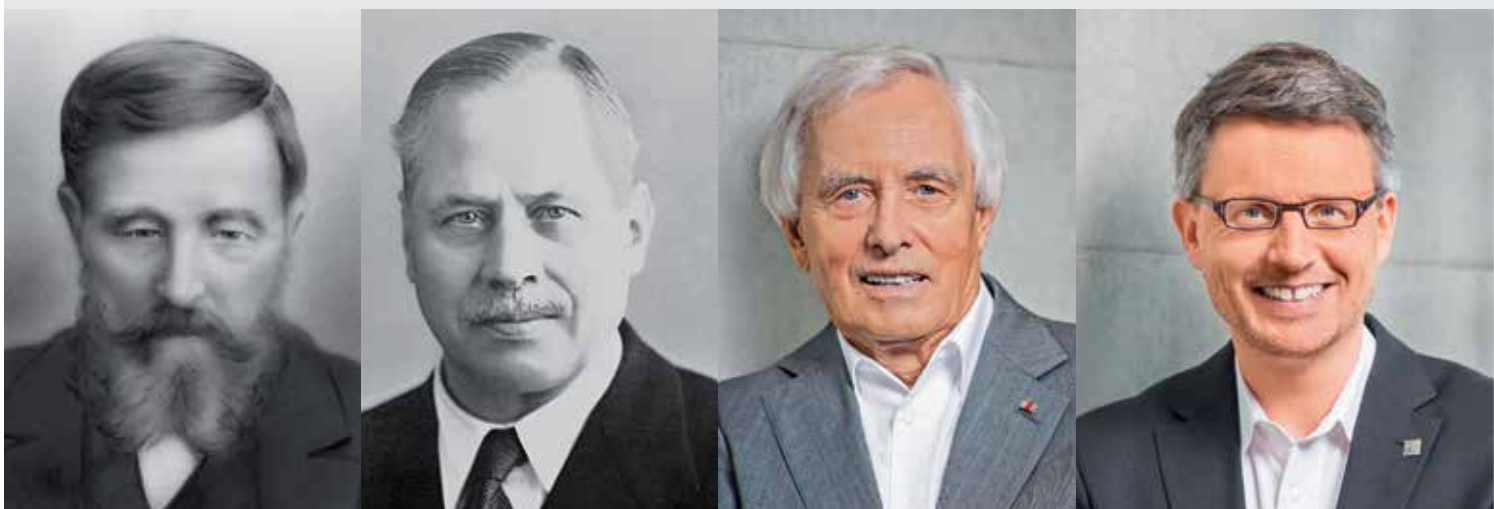

Outstanding engineering achievements. Entrepreneurial courage. And a reliable instinct for the needs of the market. These are the cornerstones of Hettich's success – the same ones we've been building on for over 125 years. Back in 1888 Karl Hettich designed a machine that revolutionised the production of anchor escapements for Black Forest cuckoo clocks. In 1928, August Hettich turned towards the furniture industry with an innovative production line for piano hinges.

Encouraged by further achievements, brothers Paul, August and Franz Hettich set up a new company at Herford in 1930. Kirchlingern became headquarters in 1966. The Hettich Group is entirely family owned.



Hettich has been operating in Australia with fully owned subsidiaries since 1988. The custom-designed Hettich Australia head office and warehouse, in Smithfield Sydney, was opened in September 2002. The facility incorporates a 7000m square national warehouse, a training centre and showroom. In addition we have State showrooms throughout Australia.

Hettich Australia and our network of distribution partners have contributed to the Cabinet Industry for more than 30 years. We believe in supporting the local organisations, groups and commercial bodies that represent the interests of the Australian cabinet industry.

Finest quality workmanship

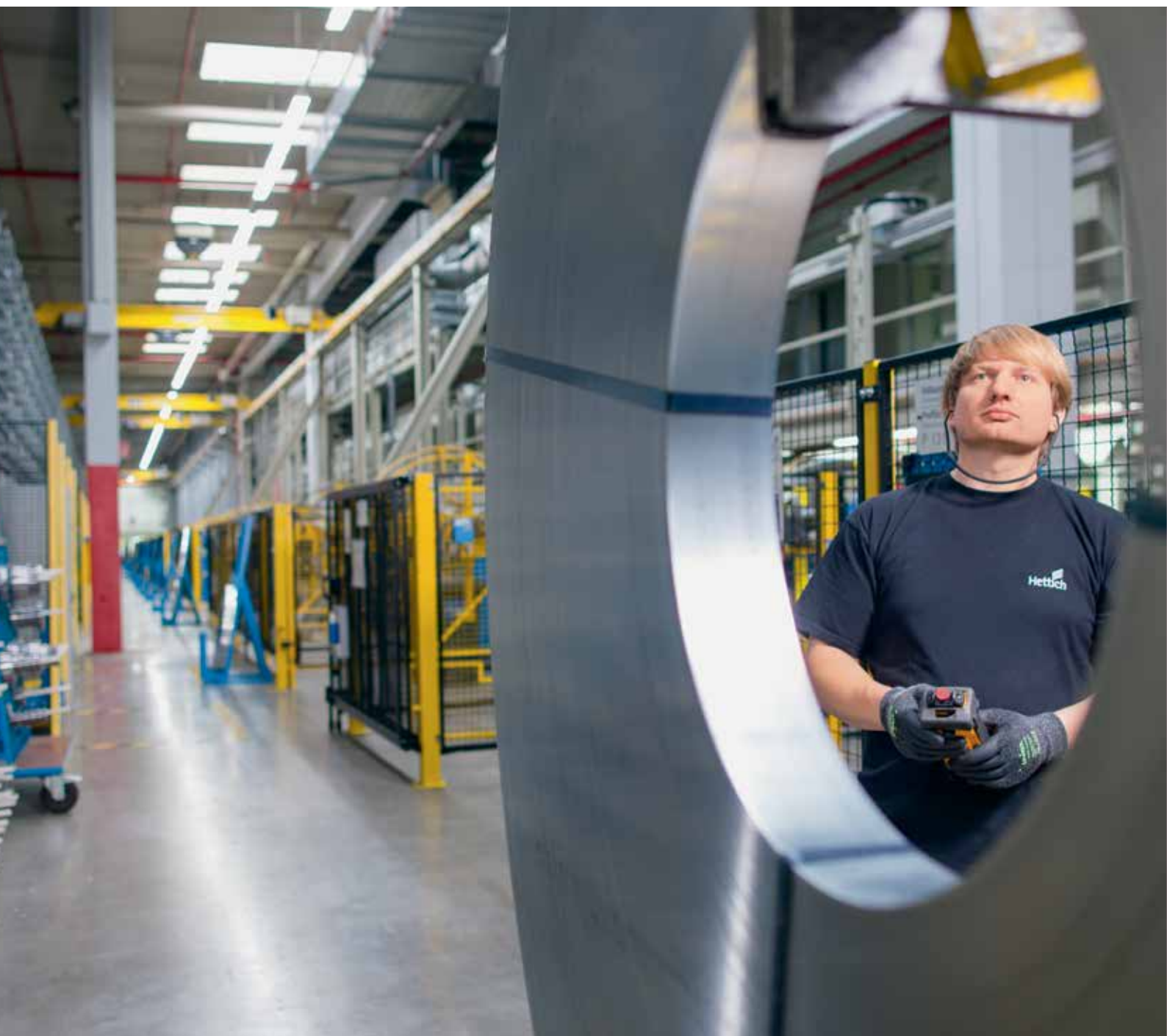

Our promise to you, our customers, is outstanding quality. In every single Hettich product. How do we keep this promise? With the passion, expertise and sophisticated production processes that make every Hettich product just what you have come to expect: reliable and long lasting, safe and easy to install and use.



We fully embrace our responsibility for the environment. We regard statutory regulations as minimum requirements which we exceed with tremendous drive and passion. At sites in an ecologically sensitive environment we apply the stringent EMAS Regulation. In everything we do, we focus on using nature's resources carefully and saving raw materials.

Our Hettich Forum office building and showroom as well as the ArciTech production facility are perfect examples of our sustainability philosophy. The new production building's primary energy requirement is 73 percent lower than limits set by the German Energy Saving Regulation. And the Hettich Forum has received the national Green Building Award.



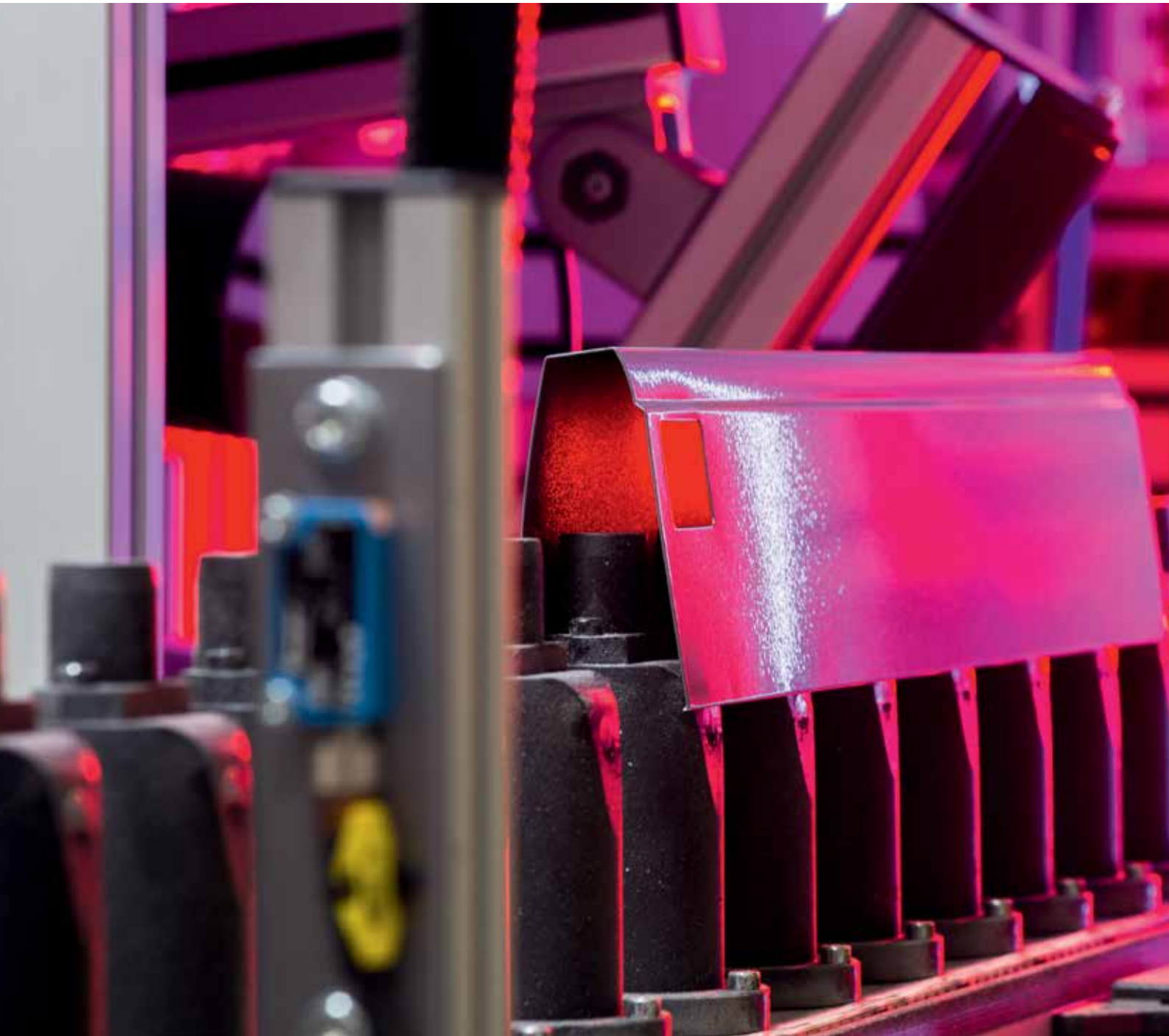

Hettich products must work safely and reliably. They must be sturdy and strong, easy to install and user friendly. This requirement profile demands ambitious research and development – and meticulous quality management.

In complex test procedures, we test every Hettich product for qualities such as durability, resistance to changing climatic conditions, safety and ergonomics.

The promise we give to our customers is: "fit and forget": once installed, Hettich products simply get on and do their job day after day after day. For furniture manufacturers, Hettich quality guarantees the reliability and long life of their own products. And the lasting satisfaction of furniture buyers.







German quality you can trust



Hinges

► Summary of ranges

| | |
|---|---|
| <p>Concealed hinges Range summary / technical comparison</p> |  |
| <p>Optional Silent System</p> |  |
| <p>Push to open opening system for handleless furniture fronts</p> |  |
| <p>Special hinges</p> |  |
| <p>Order number index</p> |  |

| | Sensys | Intermat |
|----------------------------|--|---|
| |  |  |
| Page | 11 - 60 | 62 - 89 |
| Hinge cup mounting | <ul style="list-style-type: none"> ► For screwing on ► For pressing in ► Fix fast assembly ► With premounted expanding sockets | <ul style="list-style-type: none"> ► For screwing on ► For pressing in ► With premounted expanding sockets |
| Door / door frame material | Wood, glass / wood, aluminium | Wood, glass / wood, aluminium |
| Installation | Clip on installation | Clip on installation |
| Closing system | <ul style="list-style-type: none"> ► With self closing feature ► With free swinging feature | <ul style="list-style-type: none"> ► With self closing feature ► With free swinging feature |
| Silent System | <ul style="list-style-type: none"> ► Integrated Silent System ► Without Silent System | Optional |
| Opening angle | 95° - 110°, 165° | 95°, 110°, 165° |
| Zero protrusion hinge | 165° | 165° |
| Door adjustment | 3-dimensional | 3-dimensional |
| Mounting plate system | System 8099 with oblong hole and eccentric cam height adjustment | System 8099 with oblong hole and eccentric cam height adjustment |
| Optional equipment | <ul style="list-style-type: none"> ► Opening system Push to open ► Accessories | <ul style="list-style-type: none"> ► Opening system Push to open ► Silent System ► Accessories |

Fast assembly concealed hinge

- ▶ Sensys with integrated Silent System
- ▶ Key selling points



Sensys hinge:

Ultimate Silent System perfectly designed



Stand apart from the competition!

Outstanding furniture design doesn't stop at the hinges. The easy way to meet customer demands: with well balanced, award winning Sensys design.



Less work!

No adjustment necessary. No matter whether large or heavy, the door always closes reliably and gently. As a result of the unusually wide automatic closing angle of 35°.



Maximum customer satisfaction!

No doors slamming when it's hot, no doors left standing open when it's cold. Sensys is optimised for reliable performance over a wide temperature range from + 5°C to + 40°C.



Reduce costs!

Some commonly used door formats normally hung on 3 or more hinges can often be mounted with one hinge less. As a result of best in class Silent System performance from Sensys.

Fast-assembly concealed hinge



- ▶ Sensys
- ▶ Range summary



Sensys 110° standard hinge

- ▶ Sensys 8645i / 8645 / 8675
- ▶ 110° opening angle

14 - 19



Sensys 95° thick door hinge

- ▶ Sensys 8631i / 8631 / 8661
- ▶ For narrow reveals between thick doors

20 - 25



Sensys 110° thin door hinge

- ▶ Sensys 8646i / 8646
- ▶ For thin doors

26 - 29



Sensys 165° zero protrusion hinge

- ▶ Sensys 8657i / 8657 / 8687
- ▶ For unobstructed access to storage space

30 - 35



Sensys W30 angle hinge

- ▶ Sensys 8639i W30 / 8639 W30
- ▶ For 30° face angle applications

36 - 38



Sensys W45 angle hinge

- ▶ Sensys 8639i W45 / 8639 W45 / 8669 W45
- ▶ For face angle 45°

40 - 44



Sensys W90 angle hinge

- ▶ Sensys 8639i W90 / 8639 W90 / 8669 W90
- ▶ For 90° face angle applications

46 - 50



Sensys aluminium framed hinge

- ▶ Sensys 8638i
- ▶ For aluminium framed doors

52 - 53



Intermat folding door hinge

- ▶ Intermat 9930 with cup in Sensys design
- ▶ For folding doors

54 - 56



Mounting plates

- ▶ System 8099
- ▶ For Sensys and Intermat hinges

90 - 92



Accessories

- ▶ For Sensys/Intermat

93 - 97



Technical information

58 - 60

Fast-assembly concealed hinge



- ▶ Sensys in obsidian black
- ▶ Range summary



Sensys 110° standard hinge

- ▶ Sensys 8645i / 8675
- ▶ 110° opening angle

15 / 18



Sensys 95° thick door hinge

- ▶ Sensys 8631i
- ▶ For narrow reveals between thick doors

21



Sensys 110° thin door hinge

- ▶ Sensys 8646i
- ▶ For thin doors

27

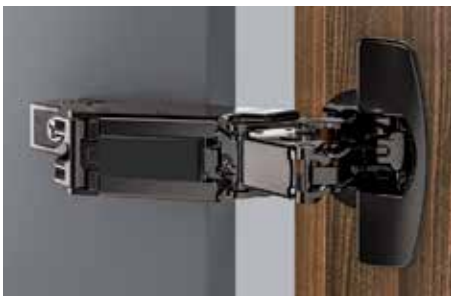

Sensys 165° zero protrusion hinge

- ▶ Sensys 8657i
- ▶ For unobstructed access to storage space

31



Sensys 165° zero protrusion hinge

- ▶ Sensys 8687
- ▶ For unobstructed access to storage space

34



Sensys W45 angle hinge

- ▶ Sensys 8639i
- ▶ For 45° face angles

41



Sensys W90 angle hinge

- ▶ Sensys 8639i W90
- ▶ For 90° face angles

47



Sensys aluminium framed hinge

- ▶ Sensys 8638i
- ▶ For aluminium framed doors

52



Sensys Intermat 9930 hinge

- ▶ Sensys 9930
- ▶ For 50° / 65° opening angle

55



Mounting plates

- ▶ System 8099
- ▶ For Sensys

92



Accessories

- ▶ For Sensys in obsidian black

95



Technical information

58 - 60

Fast assembly concealed hinge with integrated Silent System

- ▶ Sensys 8645i
- ▶ Opening angle 110°



- ▶ Concealed hinge with clip on installation and integrated Silent System
- ▶ Quality classification under EN 15570, Level 3
- ▶ For door thickness 15 - 24 mm
- ▶ Cup diameter 35 mm
- ▶ Cup depth 12.8 mm
- ▶ Integrated overlay adjustment + 2 mm / - 2 mm
- ▶ Integrated depth adjustment + 3 mm / - 2 mm
- ▶ Height adjustment at mounting plate
- ▶ Hinge arm material: nickel plated steel
- ▶ Hinge cup material: nickel plated steel

Sensys 8645i, opening angle 110°

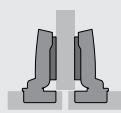
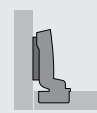
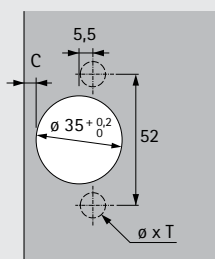
| Cup assembly | Drilling pattern | Mounting hole ϕ x T mm | Full overlay | Half overlay | Inset | PU |
|---|---|-----------------------------|---|---|---|---------|
| | | |  |  |  | |
| For screwing on TH 52 |  | - | Basis B 12,5 mm | Basis B 3 mm | Basis B -4 mm | 200 ea. |
| For pressing in TH 53 | | ϕ 10 x 11 | 9 071 205 | 9 071 206 | 9 071 207 | 200 ea. |
| Flash fast installation TH 54 | | ϕ 10 x 11 | 9 071 208 | 9 071 209 | 9 071 210 | 200 ea. |
| Fix fast installation THS 55 | | ϕ 10 x 6 | 9 071 211 | 9 073 612 | 9 073 613 | 50 ea. |
| With premounted expanding sockets TH 58 | | ϕ 10 x 11 | 9 073 614 | 9 073 615 | 9 073 616 | 50 ea. |
| | | | 9 073 567 | 9 073 568 | 9 073 688 | 200 ea. |
| | | | | | 50 ea. | |



Fast assembly concealed hinge with integrated Silent System

- ▶ Sensys 8645i in obsidian black
- ▶ 110° opening angle

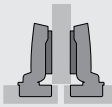

- ▶ Concealed hinge with clip on installation and integrated Silent System
- ▶ Quality classification under EN 15570, Level 3
- ▶ For door thickness of 15 - 24 mm
- ▶ Cup diameter 35 mm
- ▶ Cup depth 12.8 mm
- ▶ Integrated overlay adjustment + 2 mm / - 2 mm
- ▶ Integrated depth adjustment + 3 mm / - 2 mm
- ▶ Height adjustment at mounting plate
- ▶ All visible parts in obsidian black
- ▶ Hinge arm material: steel in obsidian black
- ▶ Hinge cup material: steel in obsidian black

Sensys 8645i, 110° opening angle

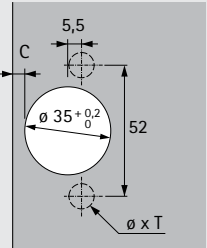
| Cup assembly | Drilling pattern | Mounting hole ø x T mm | Full overlay | Half overlay | Inset | PU |
|---|---|---------------------------|---|---|---|--------|
| | | |  |  |  | |
| For screwing on TH 52 |  | - | 9 091 738 | 9 091 739 | 9 091 740 | 50 ea. |
| With premounted expanding sockets TH 58 | | ø 10 x 11 | 9 091 771 | 9 091 772 | 9 091 773 | 50 ea. |

Fast assembly concealed hinge without integrated Silent System

- ▶ Sensys 8645
- ▶ Opening angle 110°



- ▶ Concealed hinge with clip on installation without integrated Silent System
- ▶ Quality classification under EN 15570, Level 3
- ▶ For door thickness 15 - 22 mm
- ▶ Cup diameter 35 mm
- ▶ Cup depth 12.8 mm
- ▶ Integrated overlay adjustment + 2 mm / - 2 mm
- ▶ Integrated depth adjustment + 3 mm / - 2 mm
- ▶ Height adjustment at mounting plate
- ▶ Hinge arm material: nickel plated steel
- ▶ Hinge cup material: nickel plated steel

Sensys 8645, opening angle 110°

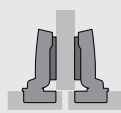
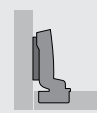
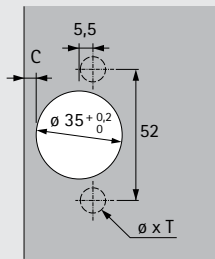
| Cup assembly | Drilling pattern | Mounting hole ϕ x T mm | Full overlay | Half overlay | Inset | PU |
|---|---|-----------------------------|---|---|---|---------|
| | | |  |  |  | |
| For screwing on TH 52 |  | - | 9 073 638 | 9 079 639 | 9 073 640 | 50 ea. |
| For pressing in TH 53 | | ϕ 10 x 11 | | 9 073 642 | 9 073 643 | 50 ea. |
| Fix fast installation THS 55 | | ϕ 10 x 6 | 9 071 262 | | | 200 ea. |
| With premounted expanding sockets TH 58 | | ϕ 10 x 11 | 9 073 644 | 9 073 645 | 9 073 646 | 50 ea. |
| | | ϕ 10 x 11 | 9 073 695 | 9 073 696 | 9 073 697 | 50 ea. |



Fast assembly concealed hinge without self closing feature

- ▶ Sensys 8675
- ▶ Opening angle 110°

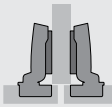

- ▶ Hinge with clip on installation without self closing feature
- ▶ For example for Push to open applications
- ▶ Quality classification under EN 15570, Level 3
- ▶ For door thickness 15 - 24 mm
- ▶ Cup diameter 35 mm
- ▶ Cup depth 12.8 mm
- ▶ Integrated overlay adjustment + 2 mm / - 2 mm
- ▶ Integrated depth adjustment + 3 mm / - 2 mm
- ▶ Height adjustment at mounting plate
- ▶ Hinge arm material: nickel plated steel
- ▶ Hinge cup material: nickel plated steel

Sensys 8675, opening angle 110°

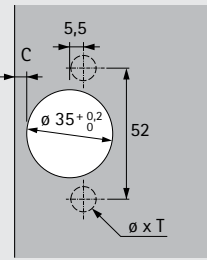
| Cup assembly | Drilling pattern | Mounting hole \varnothing x T mm | Full overlay | Half overlay | Inset | PU |
|---|---|------------------------------------|---|---|---|--------|
| | | |  |  |  | |
| For pressing in TH 53 |  | \varnothing 10 x 11 | 9 073 665 | 9 073 666 | 9 073 667 | 50 ea. |
| Fix fast installation THS 55 | | \varnothing 10 x 6 | 9 073 668 | | | 50 ea. |
| With premounted expanding sockets TH 58 | | \varnothing 10 x 11 | 9 073 704 | 9 073 705 | 9 073 706 | 50 ea. |

Fast assembly concealed hinge without self closing feature

- ▶ Sensys 8675 in obsidian black
- ▶ 110° opening angle



- ▶ Hinge with clip on installation without self closing feature
- ▶ For example, for Push to open applications
- ▶ Quality classification under EN 15570, Level 3
- ▶ For door thickness of 15 - 24 mm
- ▶ Cup diameter 35 mm
- ▶ Cup depth 12.8 mm
- ▶ Integrated overlay adjustment + 2 mm / - 2 mm
- ▶ Integrated depth adjustment + 3 mm / - 2 mm
- ▶ Height adjustment at mounting plate
- ▶ All visible parts in obsidian black
- ▶ Hinge arm material: steel in obsidian black
- ▶ Hinge cup material: steel in obsidian black

Sensys 8675, 110° opening angle

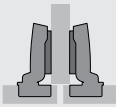
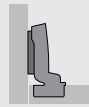
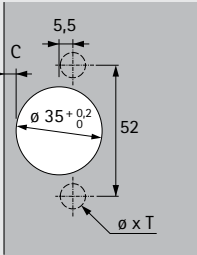
| Cup assembly | Drilling pattern | Mounting hole ø x T mm | Full overlay | Half overlay | Inset | PU |
|---|---|---------------------------|---|---|---|--------|
| | | |  |  |  | |
| For screwing on TH 52 |  | - | 9 091 741 | 9 091 742 | 9 091 743 | 50 ea. |
| With premounted expanding sockets TH 58 | | ø 10 x 11 | 9 091 774 | 9 091 775 | 9 091 776 | 50 ea. |

Fast assembly concealed hinge

- ▶ Sensys 8645i / Sensys 8645 / Sensys 8675
- ▶ Opening angle 110°

Minimum reveal per door

| Door thickness mm | Cup distance C mm | | | | | |
|-------------------|-------------------|-----|-----|-----|-----|-----|
| | 3.0 | 4.0 | 4.5 | 5.0 | 6.0 | 7.0 |
| 15 | 0.2 | 0.2 | 0.2 | 0.2 | 0.2 | 0.2 |
| 16 | 0.3 | 0.3 | 0.3 | 0.3 | 0.3 | 0.3 |
| 17 | 0.4 | 0.4 | 0.4 | 0.4 | 0.4 | 0.4 |
| 18 | 0.6 | 0.6 | 0.6 | 0.6 | 0.6 | 0.5 |
| 19 | 0.8 | 0.8 | 0.8 | 0.8 | 0.7 | 0.7 |
| 20 | 1.1 | 1.0 | 1.0 | 1.0 | 1.0 | 0.9 |
| 21 | 1.4 | 1.3 | 1.3 | 1.3 | 1.2 | 1.2 |
| 22 | 2.2 | 1.8 | 1.7 | 1.6 | 1.6 | 1.5 |
| 23 | 3.0 | 2.6 | 2.4 | 2.2 | 2.0 | 1.9 |
| 24 | 3.9 | 3.4 | 3.2 | 3.0 | 2.6 | 2.4 |

Please note:

The table entries refer to doors with an edge radius of 1 mm.

On doors with other radii, the minimum reveal changes as follows:

Radius 0 mm:
Values shown in table + 0.4 mm

Radius 3 mm:
Values shown in table - 0.6 mm

Protrusions / installed depth

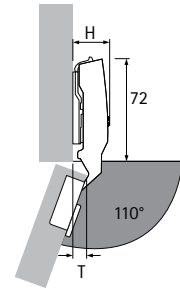

Hinge protrusion H / door protrusion T for distance D = 0 mm and cup distance C = 3 mm

| Door mounting option | H mm | T mm |
|----------------------|------|------|
| Full overlay | 25.0 | 8.5 |
| Half overlay | 31.0 | 18.0 |
| Inset | 38.0 | 25.0 |

Full overlay

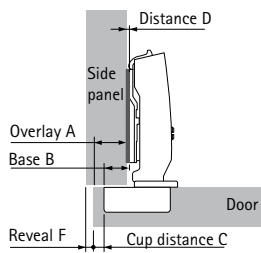

$$\text{Distance D} = \text{C} + \text{B} - \text{A}$$

$$= \text{cup distance C} + 12.5 \text{ mm} - \text{overlay A}$$

| Overlay mm | Cup distance C mm | | | | | |
|---------------|-------------------|-----|-----|-----|-----|-----|
| | 3.0 | 4.0 | 4.5 | 5.0 | 6.0 | 7.0 |
| Distance D mm | | | | | | |
| 10 | 5.5 | 6.5 | 7.0 | 7.5 | 8.5 | 9.5 |
| 11 | 4.5 | 5.5 | 6.0 | 6.5 | 7.5 | 8.5 |
| 12 | 3.5 | 4.5 | 5.0 | 5.5 | 6.5 | 7.5 |
| 13 | 2.5 | 3.5 | 4.0 | 4.5 | 5.5 | 6.5 |
| 14 | 1.5 | 2.5 | 3.0 | 3.5 | 4.5 | 5.5 |
| 15 | 0.5 | 1.5 | 2.0 | 2.5 | 3.5 | 4.5 |
| 16 | | 0.5 | 1.0 | 1.5 | 2.5 | 3.5 |
| 17 | | | 0.0 | 0.5 | 1.5 | 2.5 |
| 18 | | | | | 0.5 | 1.5 |
| 19 | | | | | | 0.5 |

Half overlay

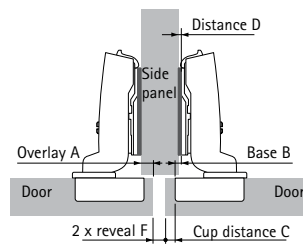

$$\text{Distance D} = \text{C} + \text{B} - \text{A}$$

$$= \text{cup distance C} + 3 \text{ mm} - \text{overlay A}$$

| Overlay mm | Cup distance C mm | | | | | |
|---------------|-------------------|-----|-----|-----|-----|-----|
| | 3.0 | 4.0 | 4.5 | 5.0 | 6.0 | 7.0 |
| Distance D mm | | | | | | |
| 0.5 | 5.5 | 6.5 | 7.0 | 7.5 | 8.5 | 9.5 |
| 1.5 | 4.5 | 5.5 | 6.0 | 6.5 | 7.5 | 8.5 |
| 2.5 | 3.5 | 4.5 | 5.0 | 5.5 | 6.5 | 7.5 |
| 3.5 | 2.5 | 3.5 | 4.0 | 4.5 | 5.5 | 6.5 |
| 4.5 | 1.5 | 2.5 | 3.0 | 3.5 | 4.5 | 5.5 |
| 5.5 | 0.5 | 1.5 | 2.0 | 2.5 | 3.5 | 4.5 |
| 6.5 | | 0.5 | 1.0 | 1.5 | 2.5 | 3.5 |
| 7.5 | | | 0.0 | 0.5 | 1.5 | 2.5 |
| 8.5 | | | | | 0.5 | 1.5 |
| 9.5 | | | | | | 0.5 |

Inset

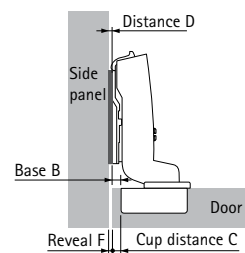

$$\text{Distance D} = \text{C} + \text{B} + \text{F}$$

$$= \text{cup distance C} - 4 \text{ mm} + \text{reveal F}$$

| Door thickness mm | Cup distance C mm | | | | | |
|-------------------|-------------------|-----|-----|-----|-----|-----|
| | 3.0 | 4.0 | 4.5 | 5.0 | 6.0 | 7.0 |
| Distance D mm | | | | | | |
| 15 | 0.2 | 0.7 | 1.2 | 2.2 | 3.2 | |
| 16 | 0.3 | 0.8 | 1.3 | 2.3 | 3.3 | |
| 17 | 0.4 | 0.9 | 1.4 | 2.4 | 3.4 | |
| 18 | 0.6 | 1.1 | 1.6 | 2.6 | 3.5 | |
| 19 | 0.8 | 1.3 | 1.8 | 2.7 | 3.7 | |
| 20 | 0.1 | 1.0 | 1.5 | 2.0 | 3.0 | 3.9 |
| 21 | 0.4 | 1.3 | 1.8 | 2.3 | 3.2 | 4.2 |
| 22 | 1.2 | 1.8 | 2.2 | 2.6 | 3.6 | 4.5 |
| 23 | 2.0 | 2.6 | 2.9 | 3.2 | 4.0 | 4.9 |
| 24 | 2.9 | 3.4 | 3.7 | 4.0 | 4.6 | 5.4 |

Advice

- ▶ For mounting plates and accessories, see page 90 - 97
- ▶ For example applications, fitting information, installation notes and quality criteria, see page 58-60



Fast assembly concealed hinge with integrated Silent System

- ▶ Sensys 8631i for thick doors
- ▶ 95° opening angle

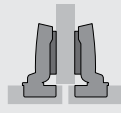

- ▶ Concealed hinge with clip on installation and integrated Silent System
- ▶ Quality classification under EN 15570, Level 2
- ▶ For door thickness of 15 – 32 mm
- ▶ Cup diameter 35 mm
- ▶ Cup depth 12.8 mm
- ▶ Integrated overlay adjustment + 2 mm / - 2 mm
- ▶ Integrated depth adjustment + 3 mm / - 2 mm
- ▶ Height adjustment at mounting plate
- ▶ Hinge arm material: nickel plated steel
- ▶ Hinge cup material: nickel plated steel

Sensys 8631i, opening angle 95°

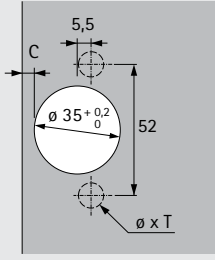
| Cup assembly | Drilling pattern | Mounting hole \varnothing x T mm | Full overlay | Half overlay | Inset | PU |
|---|---|------------------------------------|---|---|---|---------|
| | | |  |  |  | |
| For screwing on TH 52 |  | - | Base B 12,5 mm | Base B 3 mm | Base B -4 mm | 200 ea. |
| For pressing in TH 53 | | \varnothing 10 x 11 | 9 090 260 | 9 091 410 | 9 091 420 | 50 ea. |
| With premounted expanding sockets TH 58 | | \varnothing 10 x 11 | 9 090 261 | | | 200 ea. |
| Flash fast installation TH 54 | | \varnothing 10 x 11 | 9 091 406 | | | 50 ea. |
| | | \varnothing 10 x 11 | 9 091 402 | | | 50 ea. |

Fast assembly concealed hinge with integrated Silent System

- ▶ Sensys 8631i for thick doors in obsidian black
- ▶ 95° opening angle



- ▶ Concealed hinge with clip on installation and integrated Silent System
- ▶ Quality classification under EN 15570, Level 2
- ▶ For door thickness of 15 – 32 mm
- ▶ Cup diameter 35 mm
- ▶ Cup depth 12.8 mm
- ▶ Integrated overlay adjustment + 2 mm / - 2 mm
- ▶ Integrated depth adjustment + 3 mm / - 2 mm
- ▶ Height adjustment at mounting plate
- ▶ Height adjustment at mounting plate
- ▶ All visible parts in obsidian black
- ▶ Hinge arm material: steel in obsidian black
- ▶ Hinge cup material: steel in obsidian black

Sensys 8631i, opening angle 95°

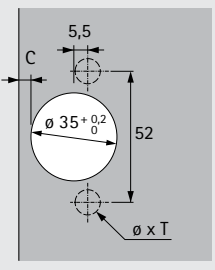
| Cup assembly | Drilling pattern | Mounting hole \varnothing x T mm | Full overlay  | |
|-----------------------|---|------------------------------------|---|--------|
| For screwing on TH 52 |  | - | Base B 12,5 mm | PU |
| | | | 9 091 753 | 50 ea. |

Fast assembly concealed hinge without integrated Silent System

- ▶ Sensys 8631 for thick doors
- ▶ 95° opening angle



- ▶ Concealed hinge with clip on installation without integrated Silent System
- ▶ Quality classification under EN 15570, Level 2
- ▶ For door thickness of 15 – 32 mm
- ▶ Cup diameter 35 mm
- ▶ Cup depth 12.8 mm
- ▶ Integrated overlay adjustment + 2 mm / - 2 mm
- ▶ Integrated depth adjustment + 3 mm / - 2 mm
- ▶ Height adjustment at mounting plate
- ▶ Hinge arm material: nickel plated steel
- ▶ Hinge cup material: nickel plated steel

Sensys 8631, opening angle 95°

Full overlay



| Cup assembly | Drilling pattern | Mounting hole ϕ x T mm | Base B 12,5 mm | PU |
|-----------------------|------------------|-----------------------------|------------------|--------|
| For screwing on TH 52 | | - | 9 091 490 | 50 ea. |

Fast assembly concealed hinge without self closing feature

- ▶ Sensys 8661 for thick doors
- ▶ 95° opening angle



- ▶ Hinge with clip on installation without self closing feature
- ▶ For example for Push to open applications
- ▶ Quality classification under EN 15570, Level 2
- ▶ For door thickness of 15 – 32 mm
- ▶ Cup diameter 35 mm
- ▶ Cup depth 12.8 mm
- ▶ Integrated overlay adjustment + 2 mm / - 2 mm
- ▶ Integrated depth adjustment + 3 mm / - 2 mm
- ▶ Height adjustment at mounting plate
- ▶ Hinge arm material: nickel plated steel
- ▶ Hinge cup material: nickel plated steel

Sensys 8661, opening angle 95°

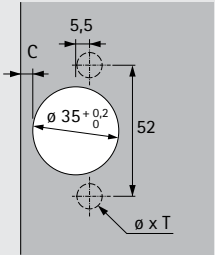
| Cup assembly | Drilling pattern | Mounting hole \varnothing x T mm | Full overlay  | |
|-----------------------|---|------------------------------------|---|--------|
| For screwing on TH 52 |  | - | Base B 12,5 mm | PU |
| | | | 9 091 580 | 50 ea. |

Fast assembly concealed hinge

- ▶ Sensys 8631i / Sensys 8631 / Sensys 8661 for thick doors
- ▶ 95° opening angle

Minimum reveal per door

| Doorthickness mm | Cup distance C mm | | | | | | |
|------------------|-------------------|-----|-----|-----|-----|-----|-----|
| | 3.0 | 4.0 | 4.5 | 5.0 | 6.0 | 7.0 | 8.0 |
| 15 | 0.1 | 0.1 | 0.1 | 0.1 | 0.1 | 0.1 | 0.1 |
| 16 | 0.1 | 0.1 | 0.1 | 0.1 | 0.1 | 0.1 | 0.1 |
| 17 | 0.2 | 0.2 | 0.2 | 0.2 | 0.2 | 0.2 | 0.2 |
| 18 | 0.2 | 0.2 | 0.2 | 0.2 | 0.2 | 0.2 | 0.2 |
| 19 | 0.3 | 0.3 | 0.3 | 0.3 | 0.3 | 0.3 | 0.3 |
| 20 | 0.4 | 0.4 | 0.4 | 0.4 | 0.4 | 0.4 | 0.4 |
| 21 | 0.6 | 0.6 | 0.6 | 0.6 | 0.6 | 0.6 | 0.6 |
| 22 | 0.7 | 0.7 | 0.7 | 0.7 | 0.7 | 0.7 | 0.7 |
| 23 | 0.9 | 0.9 | 0.9 | 0.9 | 0.9 | 0.9 | 0.9 |
| 24 | 1.1 | 1.0 | 1.0 | 1.0 | 1.0 | 1.0 | 1.0 |
| 25 | 1.3 | 1.2 | 1.2 | 1.2 | 1.2 | 1.2 | 1.2 |
| 26 | 1.5 | 1.5 | 1.4 | 1.4 | 1.4 | 1.4 | 1.4 |
| 27 | 1.7 | 1.7 | 1.7 | 1.7 | 1.6 | 1.6 | 1.6 |
| 28 | 2.0 | 2.0 | 1.9 | 1.9 | 1.9 | 1.8 | 1.8 |
| 29 | 2.9 | 2.3 | 2.2 | 2.2 | 2.2 | 2.1 | 2.1 |
| 30 | 3.8 | 3.2 | 3.0 | 2.7 | 2.5 | 2.4 | 2.4 |
| 31 | 4.8 | 4.1 | 3.8 | 3.6 | 3.1 | 2.7 | 2.7 |
| 32 | 5.7 | 5.1 | 4.8 | 4.5 | 3.9 | 3.4 | 3.0 |

Please note:

The table entries refer to doors with an edge radius of 1 mm.

On doors with other radii, the minimum reveal changes as follows:

Radius 0 mm:

Values shown in table + 0.4 mm

Protrusions / installed depth

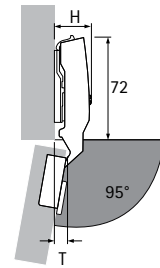

Hinge protrusion H / door protrusion T for distance D = 0 mm and cup distance C = 3 mm

| Door mounting option | H mm | T mm |
|----------------------|------|------|
| Full overlay | 24.0 | 12.5 |
| Half overlay | 28.3 | 22.0 |
| Inset | 35.3 | 29.0 |

Full overlay

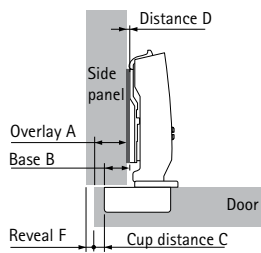

$$\text{Distance D} = C + B - A$$

$$= \text{cup distance C} + 12.5 \text{ mm} - \text{overlay A}$$

| Overlay mm | Cup distance C mm | | | | | | |
|---------------|-------------------|-----|-----|-----|-----|-----|------|
| | 3.0 | 4.0 | 4.5 | 5.0 | 6.0 | 7.0 | 8.0 |
| Distance D mm | | | | | | | |
| 10 | 5.5 | 6.5 | 7.0 | 7.5 | 8.5 | 9.5 | 10.5 |
| 11 | 4.5 | 5.5 | 6.0 | 6.5 | 7.5 | 8.5 | 9.5 |
| 12 | 3.5 | 4.5 | 5.0 | 5.5 | 6.5 | 7.5 | 8.5 |
| 13 | 2.5 | 3.5 | 4.0 | 4.5 | 5.5 | 6.5 | 7.5 |
| 14 | 1.5 | 2.5 | 3.0 | 3.5 | 4.5 | 5.5 | 6.5 |
| 15 | 0.5 | 1.5 | 2.0 | 2.5 | 3.5 | 4.5 | 5.5 |
| 16 | | 0.5 | 1.0 | 1.5 | 2.5 | 3.5 | 4.5 |
| 17 | | | 0.0 | 0.5 | 1.5 | 2.5 | 3.5 |
| 18 | | | | | 0.5 | 1.5 | 2.5 |
| 19 | | | | | | 0.5 | 1.5 |
| 20 | | | | | | | 0.5 |

Half overlay

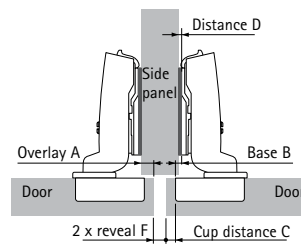

$$\text{Distance D} = C + B - A$$

$$= \text{cup distance C} + 3 \text{ mm} - \text{overlay A}$$

| Overlay mm | Cup distance C mm | | | | | | |
|---------------|-------------------|-----|-----|-----|-----|-----|------|
| | 3.0 | 4.0 | 4.5 | 5.0 | 6.0 | 7.0 | 8.0 |
| Distance D mm | | | | | | | |
| 0.5 | 5.5 | 6.5 | 7.0 | 7.5 | 8.5 | 9.5 | 10.5 |
| 1.5 | 4.5 | 5.5 | 6.0 | 6.5 | 7.5 | 8.5 | 9.5 |
| 2.5 | 3.5 | 4.5 | 5.0 | 5.5 | 6.5 | 7.5 | 8.5 |
| 3.5 | 2.5 | 3.5 | 4.0 | 4.5 | 5.5 | 6.5 | 7.5 |
| 4.5 | 1.5 | 2.5 | 3.0 | 3.5 | 4.5 | 5.5 | 6.5 |
| 5.5 | 0.5 | 1.5 | 2.0 | 2.5 | 3.5 | 4.5 | 5.5 |
| 6.5 | | 0.5 | 1.0 | 1.5 | 2.5 | 3.5 | 4.5 |
| 7.5 | | | 0.0 | 0.5 | 1.5 | 2.5 | 3.5 |
| 8.5 | | | | | 0.5 | 1.5 | 2.5 |
| 9.5 | | | | | | 0.5 | 1.5 |
| 10.5 | | | | | | | 0.5 |

Inset

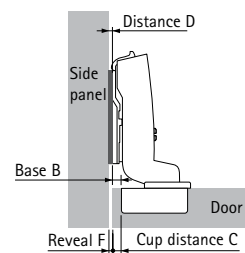

$$\text{Distance D} = C + B + F$$

$$= \text{cup distance C} - 4 \text{ mm} + \text{reveal F}$$

| Doorthickness mm | Cup distance C mm | | | | | | |
|------------------|-------------------|-----|-----|-----|-----|-----|-----|
| | 3.0 | 4.0 | 4.5 | 5.0 | 6.0 | 7.0 | 8.0 |
| Distance D mm | | | | | | | |
| 15 | 0.1 | 0.6 | 1.1 | 2.1 | 3.1 | 4.1 | |
| 16 | 0.1 | 0.6 | 1.1 | 2.1 | 3.1 | 4.1 | |
| 17 | 0.2 | 0.7 | 1.2 | 2.2 | 3.2 | 4.2 | |
| 18 | 0.2 | 0.7 | 1.2 | 2.2 | 3.2 | 4.2 | |
| 19 | 0.3 | 0.8 | 1.3 | 2.3 | 3.3 | 4.3 | |
| 20 | 0.4 | 0.9 | 1.4 | 2.4 | 3.4 | 4.4 | |
| 21 | 0.6 | 1.1 | 1.6 | 2.6 | 3.6 | 4.6 | |
| 22 | 0.7 | 1.2 | 1.7 | 2.7 | 3.7 | 4.7 | |
| 23 | 0.9 | 1.4 | 1.9 | 2.9 | 3.9 | 4.9 | |
| 24 | 0.1 | 1.0 | 1.5 | 2.0 | 3.0 | 4.0 | 5.0 |
| 25 | 0.3 | 1.2 | 1.7 | 2.2 | 3.2 | 4.2 | 5.2 |
| 26 | 0.5 | 1.5 | 1.9 | 2.4 | 3.4 | 4.4 | 5.4 |
| 27 | 0.7 | 1.7 | 2.2 | 2.7 | 3.6 | 4.6 | 5.6 |
| 28 | 1.0 | 2.0 | 2.4 | 2.9 | 3.9 | 4.8 | 5.8 |
| 29 | 1.9 | 2.3 | 2.7 | 3.2 | 4.2 | 5.1 | 6.1 |
| 30 | 2.8 | 3.2 | 3.5 | 3.7 | 4.5 | 5.4 | 6.4 |
| 31 | 3.8 | 4.1 | 4.3 | 4.6 | 5.1 | 5.7 | 6.7 |
| 32 | 4.7 | 5.1 | 5.3 | 5.5 | 5.9 | 6.4 | 7.0 |

Advice

- ▶ For mounting plates and accessories, see page 90 - 97
- ▶ For example applications, fitting information, installation notes and quality criteria, see page 58 - 60

Fast assembly concealed hinge

- ▶ Sensys 8631i / Sensys 8631 / Sensys 8661 for thick doors
- ▶ 95° opening angle

Door contours for minimum reveal application - scale 1:1

The values shown in the Minimum reveal table refer to an edge radius of 1 mm. Smaller reveal values apply if door edges are more rounded.
To obtain a minimum reveal application, the chosen door contour must lie within the template illustrated below. All contours protruding beyond the template will increase the reveal accordingly.



Example of minimum reveal application

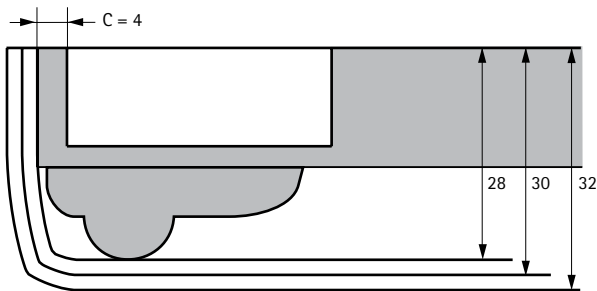

| Example of minimum reveal application | |
|---------------------------------------|-------|
| Door thickness | 16 mm |
| Profile thickness | 12 mm |
| Overall thickness | 28 mm |
| Cup distance C | 4 mm |

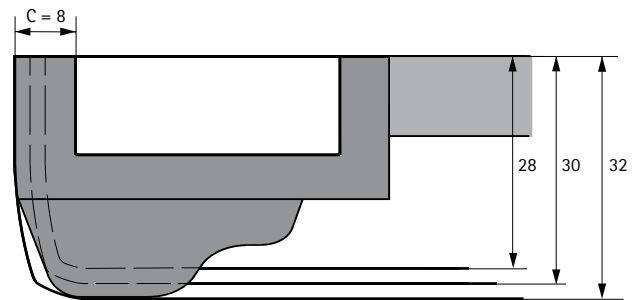

| Example of minimum reveal application | |
|---------------------------------------|-------|
| Door thickness | 19 mm |
| Profile thickness | 13 mm |
| Overall thickness | 32 mm |
| Cup distance C | 8 mm |

Fast assembly concealed hinge with integrated Silent System

- ▶ Sensys 8646i for thin doors
- ▶ 110° opening angle

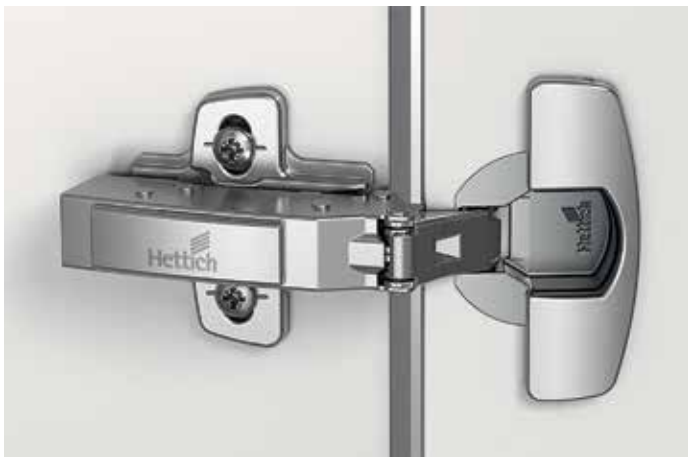

- ▶ Concealed hinge with clip on installation and integrated Silent System
- ▶ For door thickness of 10 – 16 mm
- ▶ Cup diameter 35 mm
- ▶ Cup depth 7.8 mm
- ▶ Integrated overlay adjustment + 2 mm / - 2 mm
- ▶ Integrated depth adjustment + 3 mm / - 2 mm
- ▶ Height adjustment at mounting plate
- ▶ Hinge arm material: nickel plated steel
- ▶ Hinge cup material: nickel plated steel
- ▶ **Note:** The method selected for attaching the hinge to the door must be suitable for the type and quality of door material and tested for a secure fit.

Sensys 8646i, opening angle 110°

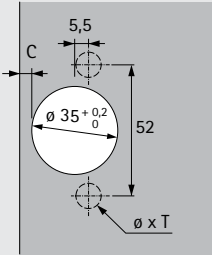
| Cup assembly | Drilling pattern | Mounting hole \varnothing x T mm | Full overlay  | |
|---|---|------------------------------------|---|------------------|
| For screwing on TH 52 |  | - | Base B 12,5 mm | PU |
| For pressing in TH 53 | | \varnothing 10 x 8 | 9 094 270 | 50 ea. |
| With premounted expanding sockets TH 58 | | \varnothing 10 x 8 | 9 094 271 | 9 094 276 |

Sensys 8646i, opening angle 110°

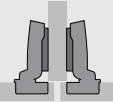
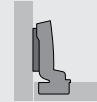
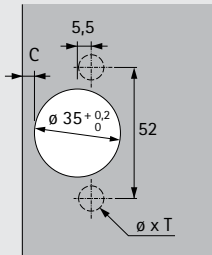
| Cup assembly | Drilling pattern | Mounting hole \varnothing x T mm | Half overlay  | Inset  | |
|---|---|------------------------------------|---|--|------------------|
| For screwing on TH 52 |  | - | Base B 3 mm | Base B -4 mm | PU |
| For pressing in TH 53 | | \varnothing 10 x 8 | 9 094 280 | 9 094 290 | 50 ea. |
| With premounted expanding sockets TH 58 | | \varnothing 10 x 8 | 9 094 281 | 9 094 286 | 9 094 291 |

Fast assembly concealed hinge with integrated Silent System

- ▶ Sensys 8646i for thin doors in obsidian black
- ▶ 110° opening angle



- ▶ Concealed hinge with clip on installation and integrated Silent System
- ▶ For door thickness of 10 – 16 mm
- ▶ Cup diameter 35 mm
- ▶ Cup depth 7.8 mm
- ▶ Integrated overlay adjustment + 2 mm / - 2 mm
- ▶ Integrated depth adjustment + 3 mm / - 2 mm
- ▶ Height adjustment at mounting plate
- ▶ All visible parts in obsidian black
- ▶ Hinge arm material: steel in obsidian black
- ▶ Hinge cup material: steel in obsidian black
- ▶ **Note:** The method selected for attaching the hinge to the door must be suitable for the type and quality of door material and tested for a secure fit.

Sensys 8646i, opening angle 110°

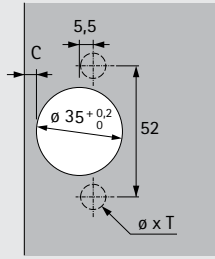
| | | | Full overlay | |
|---|---|------------------------------------|---|--------|
| Cup assembly | Drilling pattern | Mounting hole \varnothing x T mm |  Base B 12,5 mm | PU |
| For screwing on TH 52 |  | - | 9 091 761 | 50 ea. |
| With premounted expanding sockets TH 58 | | \varnothing 10 x 8 | 9 091 793 | 50 ea. |

Fast assembly concealed hinge without integrated Silent System

- ▶ Sensys 8646 for thin doors
- ▶ 110° opening angle

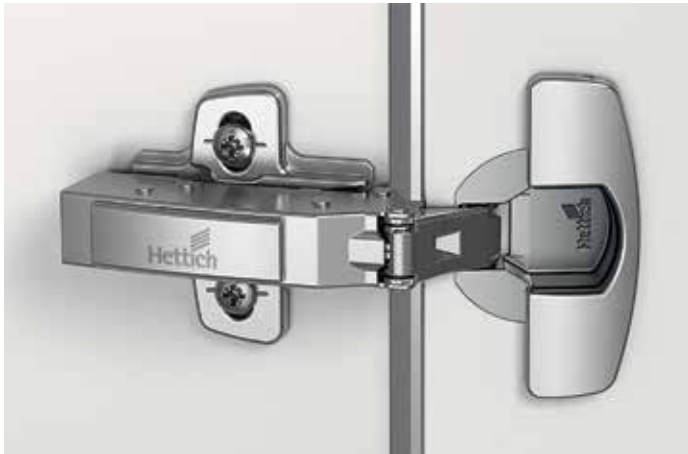

- ▶ Concealed hinge with clip on installation without integrated Silent System
- ▶ For door thickness of 10 - 16 mm
- ▶ Cup diameter 35 mm
- ▶ Cup depth 7.8 mm
- ▶ Integrated overlay adjustment + 2 mm / - 2 mm
- ▶ Integrated depth adjustment + 3 mm / - 2 mm
- ▶ Height adjustment at mounting plate
- ▶ Hinge arm material: nickel plated steel
- ▶ Hinge cup material: nickel plated steel
- ▶ **Note:** The method selected for attaching the hinge to the door must be suitable for the type and quality of door material and tested for a secure fit.

Sensys 8646, opening angle 110°

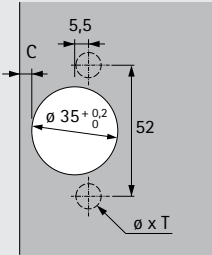
| | | | Full overlay | |
|---|---|------------------------------------|---|--------|
| Cup assembly | Drilling pattern | Mounting hole \varnothing x T mm |  Base B 12,5 mm | PU |
| For screwing on TH 52 |  | - | 9 094 360 | 50 ea. |
| For pressing in TH 53 | | \varnothing 10 x 8 | 9 094 361 | 50 ea. |
| With premounted expanding sockets TH 58 | | \varnothing 10 x 8 | 9 094 366 | 50 ea. |

Fast assembly concealed hinge

- ▶ Sensys 8646i / Sensys 8646
- ▶ 110° opening angle

Minimum reveal per door

| Door thickness mm | Cup distance C mm | | | | | |
|-------------------|-------------------|-----|-----|-----|-----|-----|
| | 3.0 | 4.0 | 4.5 | 5.0 | 6.0 | 7.0 |
| 10 | 0.1 | 0.1 | 0.1 | 0.1 | 0.1 | 0.1 |
| 11 | 0.2 | 0.2 | 0.2 | 0.2 | 0.2 | 0.2 |
| 12 | 0.4 | 0.4 | 0.4 | 0.4 | 0.4 | 0.4 |
| 13 | 0.6 | 0.6 | 0.5 | 0.5 | 0.5 | 0.5 |
| 14 | 0.8 | 0.8 | 0.7 | 0.7 | 0.7 | 0.7 |
| 15 | 1.0 | 1.0 | 1.0 | 1.0 | 0.9 | 0.9 |
| 16 | 1.3 | 1.3 | 1.3 | 1.2 | 1.2 | 1.2 |

Please note:

The table entries refer to doors with an edge radius of 1 mm.

Protrusions / installed depth

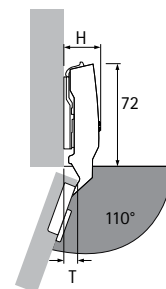

Hinge protrusion H / door protrusion T for distance D = 0 mm and cup distance C = 3 mm

| Door mounting option | H mm | T mm |
|----------------------|------|------|
| Full overlay | 25.0 | 8.5 |
| Half overlay | 31.0 | 18.0 |
| Inset | 38.0 | 25.0 |

Full overlay

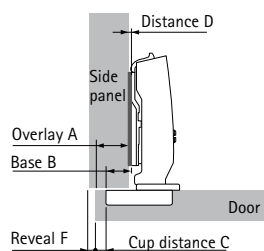

$$\text{Distance D} = \text{C} + \text{B} - \text{A}$$

= cup distance C + 12.5 mm - overlay A

| Overlay mm | Cup distance C mm | | | | | |
|---------------|-------------------|-----|-----|-----|-----|-----|
| | 3.0 | 4.0 | 4.5 | 5.0 | 6.0 | 7.0 |
| Distance D mm | | | | | | |
| 10 | 5.5 | 6.5 | 7.0 | 7.5 | 8.5 | 9.5 |
| 11 | 4.5 | 5.5 | 6.0 | 6.5 | 7.5 | 8.5 |
| 12 | 3.5 | 4.5 | 5.0 | 5.5 | 6.5 | 7.5 |
| 13 | 2.5 | 3.5 | 4.0 | 4.5 | 5.5 | 6.5 |
| 14 | 1.5 | 2.5 | 3.0 | 3.5 | 4.5 | 5.5 |
| 15 | 0.5 | 1.5 | 2.0 | 2.5 | 3.5 | 4.5 |
| 16 | | 0.5 | 1.0 | 1.5 | 2.5 | 3.5 |
| 17 | | | 0.0 | 0.5 | 1.5 | 2.5 |
| 18 | | | | | 0.5 | 1.5 |
| 19 | | | | | | 0.5 |

Half overlay

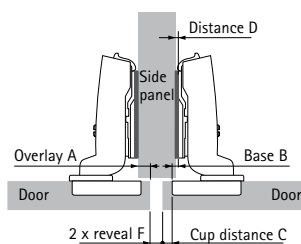

$$\text{Distance D} = \text{C} + \text{B} - \text{A}$$

= cup distance C + 3 mm - overlay A

| Overlay mm | Cup distance C mm | | | | | |
|---------------|-------------------|-----|-----|-----|-----|-----|
| | 3.0 | 4.0 | 4.5 | 5.0 | 6.0 | 7.0 |
| Distance D mm | | | | | | |
| 0.5 | 5.5 | 6.5 | 7.0 | 7.5 | 8.5 | 9.5 |
| 1.5 | 4.5 | 5.5 | 6.0 | 6.5 | 7.5 | 8.5 |
| 2.5 | 3.5 | 4.5 | 5.0 | 5.5 | 6.5 | 7.5 |
| 3.5 | 2.5 | 3.5 | 4.0 | 4.5 | 5.5 | 6.5 |
| 4.5 | 1.5 | 2.5 | 3.0 | 3.5 | 4.5 | 5.5 |
| 5.5 | 0.5 | 1.5 | 2.0 | 2.5 | 3.5 | 4.5 |
| 6.5 | | 0.5 | 1.0 | 1.5 | 2.5 | 3.5 |
| 7.5 | | | 0.0 | 0.5 | 1.5 | 2.5 |
| 8.5 | | | | | 0.5 | 1.5 |
| 9.5 | | | | | | 0.5 |

Inset

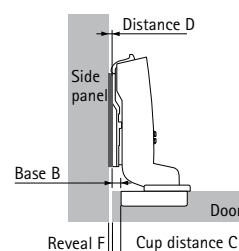

$$\text{Distance D} = \text{C} + \text{B} + \text{F}$$

= cup distance C - 4 mm + reveal F

| Door thickness mm | Cup distance C mm | | | | | |
|-------------------|-------------------|-----|-----|-----|-----|-----|
| | 3.0 | 4.0 | 4.5 | 5.0 | 6.0 | 7.0 |
| Distance D mm | | | | | | |
| 10 | 0.1 | 0.6 | 1.1 | 2.1 | 3.1 | |
| 11 | 0.2 | 0.7 | 1.2 | 2.2 | 3.2 | |
| 12 | 0.4 | 0.9 | 1.4 | 2.4 | 3.3 | |
| 13 | 0.6 | 1.0 | 1.5 | 2.5 | 3.5 | |
| 14 | 0.8 | 1.2 | 1.7 | 2.7 | 3.7 | |
| 15 | 0.0 | 1.0 | 1.5 | 2.0 | 2.9 | 3.9 |
| 16 | 0.3 | 1.3 | 1.8 | 2.2 | 3.2 | 4.2 |

Advice

- ▶ For mounting plates and accessories, see page 90 - 97
- ▶ For example applications, fitting information, installation notes and quality criteria, see page 58 - 60



Fast assembly concealed hinge with integrated Silent System

- ▶ Sensys 8657i zero protrusion hinge
- ▶ Opening angle 165°



- ▶ Concealed hinge with clip on installation and integrated Silent System
- ▶ Quality classification under EN 15570, Level 3
- ▶ For door thickness of 15 – 32 mm
- ▶ Cup diameter 35 mm
- ▶ Cup depth 11.6 mm
- ▶ Integrated overlay adjustment + 2 mm / - 2 mm
- ▶ Integrated depth adjustment + 3 mm / - 2 mm
- ▶ Height adjustment at mounting plate
- ▶ Opening angle can be reduced by means of optional accessories
- ▶ Zero protrusion hinge
- ▶ Hinge arm material: nickel plated steel
- ▶ Hinge cup material: nickel plated steel

Sensys 8657i, opening angle 165°

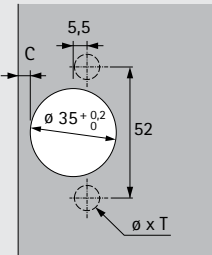
| Cup assembly | Drilling pattern | Mounting hole \varnothing x T mm | Full overlay | Half overlay | PU |
|---|---|------------------------------------|---|---|--------|
| | | |  |  | |
| For screwing on TH 52 |  | - | 9 099 540 | | 50 ea. |
| For pressing in TH 53 | | \varnothing 10 x 11 | 9 099 541 | 9 099 551 | 50 ea. |
| Fix fast installation THS 55 | | \varnothing 10 x 6 | 9 099 543 | | 50 ea. |
| With premounted expanding sockets TH 58 | | \varnothing 10 x 11 | 9 099 546 | | 50 ea. |
| Flash fast installation TH 54 | | \varnothing 10 x 11 | 9 099 542 | | 50 ea. |



Fast assembly concealed hinge with integrated Silent System

- ▶ Sensys 8657i in obsidian black, zero protrusion hinge
- ▶ 165° opening angle



- ▶ Concealed hinge with clip on installation and integrated Silent System
- ▶ Quality classification under EN 15570, Level 3
- ▶ For door thickness of 15 – 32 mm
- ▶ Cup diameter 35 mm
- ▶ Cup depth 11.6 mm
- ▶ Integrated overlay adjustment + 2 mm / - 2 mm
- ▶ Integrated depth adjustment + 3 mm / - 2 mm
- ▶ Height adjustment at mounting plate
- ▶ Opening angle can be reduced by means of optional accessory
- ▶ Zero protrusion hinge
- ▶ All visible parts in obsidian black
- ▶ Hinge arm material: steel in obsidian black
- ▶ Hinge cup material: steel in obsidian black

Sensys 8657i, 165° opening angle

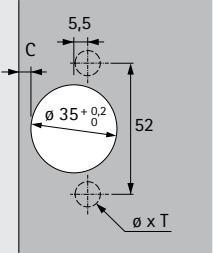
| Cup assembly | Drilling pattern | Mounting hole ø x T mm | Full overlay | Half overlay | PU |
|---|---|---------------------------|---|---|--------|
| | | |  |  | |
| For screwing on TH 52 |  | - | Base B 12.5 mm 9 091 767 | Base B 3 mm 9 091 768 | 50 ea. |
| With premounted expanding sockets TH 58 | | ø 10 x 11 | 9 091 789 | | 50 ea. |



Fast assembly concealed hinge without integrated Silent System

- ▶ Sensys 8657, zero protrusion hinge
- ▶ Opening angle 165°



- ▶ Concealed hinge with clip on installation without integrated Silent System
- ▶ Quality classification under EN 15570, Level 3
- ▶ For door thickness of 15 – 32 mm
- ▶ Cup diameter 35 mm
- ▶ Cup depth 11.6 mm
- ▶ Integrated overlay adjustment + 2 mm / - 2 mm
- ▶ Integrated depth adjustment +3 mm / - 2 mm
- ▶ Height adjustment at mounting plate
- ▶ Opening angle can be reduced by means of optional accessories
- ▶ Zero protrusion hinge
- ▶ Hinge arm material: nickel plated steel
- ▶ Hinge cup material: nickel plated steel

Sensys 8657, opening angle 165°

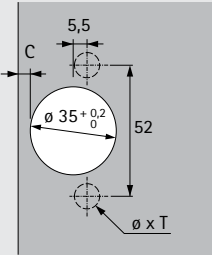
| Cup assembly | Drilling pattern | Mounting hole \varnothing x T mm | Full overlay | Half overlay | PU |
|---|---|------------------------------------|---|---|--------|
| | | |  |  | |
| For screwing on TH 52 |  | - | 9 099 600 | 9 099 610 | 50 ea. |
| For pressing in TH 53 | | \varnothing 10 x 11 | 9 099 601 | | 50 ea. |
| Fix fast installation THS 55 | | \varnothing 10 x 6 | 9 099 603 | | 50 ea. |
| With premounted expanding sockets TH 58 | | \varnothing 10 x 11 | 9 099 606 | | 50 ea. |



Fast assembly concealed hinge without self closing feature

- ▶ Sensys 8687, zero protrusion hinge
- ▶ Opening angle 165°



- ▶ Hinge with clip on installation without self closing feature
- ▶ For example for Push to open applications
- ▶ Quality classification under EN 15570, Level 3
- ▶ For door thickness of 15 – 32 mm
- ▶ Cup diameter 35 mm
- ▶ Cup depth 11.6 mm
- ▶ Integrated overlay adjustment + 2 mm / - 2 mm
- ▶ Integrated depth adjustment + 3 mm / - 2 mm
- ▶ Height adjustment at mounting plate
- ▶ Opening angle can be reduced by means of optional accessories
- ▶ Zero protrusion hinge
- ▶ Hinge arm material: nickel plated steel
- ▶ Hinge cup material: nickel plated steel

Sensys 8687, opening angle 165°

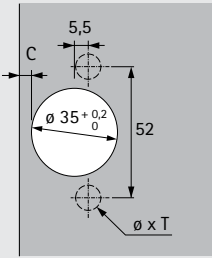
| Cup assembly | Drilling pattern | Mounting hole \varnothing x T mm | Full overlay | Half overlay | PU |
|---|---|------------------------------------|---|---|--------|
| | | |  |  | |
| For pressing in TH 53 |  | $\varnothing 10 \times 11$ | 9 099 661 | | 50 ea. |
| Fix fast installation THS 55 | | $\varnothing 10 \times 6$ | 9 099 663 | 9 099 673 | 50 ea. |
| With premounted expanding sockets TH 58 | | $\varnothing 10 \times 11$ | 9 099 666 | | 50 ea. |

Fast assembly concealed hinge without self closing feature

- ▶ Sensys 8687 in obsidian black, zero protrusion hinge
- ▶ 165° opening angle



- ▶ Hinge with clip on installation without self closing feature
- ▶ For example, for Push to open applications
- ▶ Quality classification under EN 15570, Level 3
- ▶ For door thickness of 15 – 32 mm
- ▶ Cup diameter 35 mm
- ▶ Cup depth 11.6 mm
- ▶ Integrated overlay adjustment + 2 mm / - 2 mm
- ▶ Integrated depth adjustment + 3 mm / - 2 mm
- ▶ Height adjustment at mounting plate
- ▶ Opening angle can be reduced by means of optional accessory
- ▶ Zero protrusion hinge
- ▶ All visible parts in obsidian black
- ▶ Hinge arm material: steel in obsidian black
- ▶ Hinge cup material: steel in obsidian black

Sensys 8687, 165° opening angle

| Cup assembly | Drilling pattern | Mounting hole ø x T mm | Full overlay | Half overlay | PU |
|---|------------------|---------------------------|----------------|---------------|--------|
| | | | Base B 12.5 mm | Base B 3 mm | |
| For screwing on TH 52 | | - | 9 091 769 | 9 091 770 | 50 ea. |
| With premounted expanding sockets TH 58 | | ø 10 x 11 | 9 091 791 | | 50 ea. |

Fast assembly concealed hinge

- ▶ Sensys 8657i / Sensys 8657 / Sensys 8687
- ▶ Opening angle 165°

Minimum reveal per door

| Door thickness mm | Cup distance C mm | | | | | |
|-------------------|-------------------|-----|-----|-----|-----|-----|
| | 3.0 | 4.0 | 4.5 | 5.0 | 6.0 | 7.0 |
| 15 | 0.0 | 0.0 | 0.0 | 0.0 | 0.0 | 0.0 |
| 16 | 0.0 | 0.0 | 0.0 | 0.0 | 0.0 | 0.0 |
| 17 | 0.0 | 0.0 | 0.0 | 0.0 | 0.0 | 0.0 |
| 18 | 0.0 | 0.0 | 0.0 | 0.0 | 0.0 | 0.0 |
| 19 | 0.0 | 0.0 | 0.0 | 0.0 | 0.0 | 0.0 |
| 20 | 0.0 | 0.0 | 0.0 | 0.0 | 0.0 | 0.0 |
| 21 | 0.0 | 0.0 | 0.0 | 0.0 | 0.0 | 0.0 |
| 22 | 0.0 | 0.0 | 0.0 | 0.0 | 0.0 | 0.0 |
| 23 | 0.0 | 0.0 | 0.0 | 0.0 | 0.0 | 0.0 |
| 24 | 0.0 | 0.0 | 0.0 | 0.0 | 0.0 | 0.0 |
| 25 | 0.0 | 0.0 | 0.0 | 0.0 | 0.0 | 0.0 |
| 26 | 0.1 | 0.1 | 0.1 | 0.1 | 0.1 | 0.1 |
| 27 | 0.1 | 0.1 | 0.1 | 0.1 | 0.1 | 0.1 |
| 28 | 0.2 | 0.2 | 0.2 | 0.2 | 0.2 | 0.3 |
| 29* | 0.4 | 0.4 | 0.4 | 0.4 | 0.5 | 0.6 |
| 30** | 0.7 | 0.7 | 0.8 | 0.8 | 1.0 | 1.1 |
| 31** | 1.1 | 1.2 | 1.3 | 1.4 | 1.6 | |
| 32** | 1.7 | 1.9 | 2.0 | 2.2 | | |

*when using the opening angle limiter at 120°
 **when using the opening angle limiter at 105°

Protrusions / installed depth

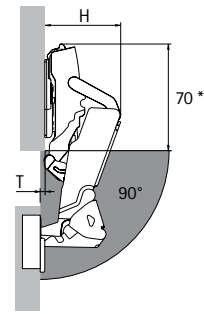

No door protrusion T up to distance D = 3, unobstructed interior for pull-outs.
 *Hinge closed: 80 mm

| Door mounting option | H mm (max. at 30°) | T mm (90°, D0) |
|----------------------|--------------------|----------------|
| Full overlay | 66 | -3 |
| Half overlay | 75.5 | 6.5 |

Full overlay

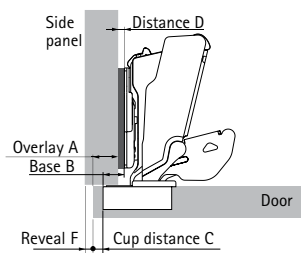

$$\text{Distance D} = \text{C} + \text{B} - \text{A}$$

= cup distance C + 12.5 mm - overlay A

| Overlay mm | Cup distance C mm | | | | | |
|---------------|-------------------|-----|-----|-----|-----|-----|
| | 3.0 | 4.0 | 4.5 | 5.0 | 6.0 | 7.0 |
| Distance D mm | | | | | | |
| 10 | 5.5 | 6.5 | 7.0 | 7.5 | 8.5 | 9.5 |
| 11 | 4.5 | 5.5 | 6.0 | 6.5 | 7.5 | 8.5 |
| 12 | 3.5 | 4.5 | 5.0 | 5.5 | 6.5 | 7.5 |
| 13 | 2.5 | 3.5 | 4.0 | 4.5 | 5.5 | 6.5 |
| 14 | 1.5 | 2.5 | 3.0 | 3.5 | 4.5 | 5.5 |
| 15 | 0.5 | 1.5 | 2.0 | 2.5 | 3.5 | 4.5 |
| 16 | | 0.5 | 1.0 | 1.5 | 2.5 | 3.5 |
| 17 | | | 0.0 | 0.5 | 1.5 | 2.5 |
| 18 | | | | | 0.5 | 1.5 |
| 19 | | | | | | 0.5 |

Half overlay

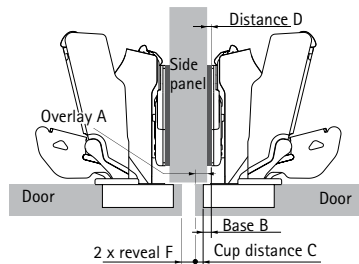

$$\text{Distance D} = \text{C} + \text{B} - \text{A}$$

= cup distance C + 3 mm - overlay A

| Overlay mm | Cup distance C mm | | | | | |
|---------------|-------------------|-----|-----|------|------|------|
| | 3.0 | 4.0 | 4.5 | 5.0 | 6.0 | 7.0 |
| Distance D mm | | | | | | |
| - 2 | 8.0 | 9.0 | 9.5 | 10.0 | 11.0 | 12.0 |
| - 1 | 7.0 | 8.0 | 8.5 | 9.0 | 10.0 | 11.0 |
| 0 | 6.0 | 7.0 | 7.5 | 8.0 | 9.0 | 10.0 |
| 1 | 5.0 | 6.0 | 6.5 | 7.0 | 8.0 | 9.0 |
| 2 | 4.0 | 5.0 | 5.5 | 6.0 | 7.0 | 8.0 |
| 3 | 3.0 | 4.0 | 4.5 | 5.0 | 6.0 | 7.0 |
| 4 | 2.0 | 3.0 | 3.5 | 4.0 | 5.0 | 6.0 |
| 5 | 1.0 | 2.0 | 2.5 | 3.0 | 4.0 | 5.0 |
| 6 | 0.0 | 1.0 | 1.5 | 2.0 | 3.0 | 4.0 |
| 7 | | 0.0 | 0.5 | 1.0 | 2.0 | 3.0 |
| 8 | | | | 0.0 | 1.0 | 2.0 |
| 9 | | | | | 0.0 | 1.0 |
| 10 | | | | | | 0.0 |

Advice

- ▶ For mounting plates and accessories, see page 90 - 97
- ▶ For example applications, fitting information, installation notes and quality criteria, see page 58 - 60

Fast assembly concealed hinge with integrated Silent System

- ▶ Sensys 8639i W30
- ▶ For 30° face angle, 95° opening angle



- ▶ Concealed hinge with clip on installation and integrated Silent System
- ▶ Quality classification under EN 15570, Level 3
- ▶ For diagonal base units, carcass angle 120°
- ▶ For door thickness 15 - 28 mm
- ▶ Cup diameter 35 mm
- ▶ Cup depth 12.8 mm
- ▶ Integrated overlay adjustment + 2 mm / - 2 mm
- ▶ Integrated depth adjustment + 3 mm / - 2 mm
- ▶ Height adjustment at mounting plate
- ▶ Hinge arm material: zinc die-cast nickel plated
- ▶ Hinge cup material: nickel plated steel

Sensys 8639i W30, opening angle 95°

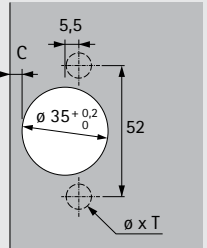
| Cup assembly | Drilling pattern | Mounting hole \varnothing x T mm | Overlay  | PU |
|------------------------------|---|------------------------------------|--|--------|
| For screwing on TH 52 |  | - | Basis B 2 mm 9 088 016 | 50 ea. |
| For pressing in TH 53 | | \varnothing 10 x 11 | 9 088 034 | 50 ea. |
| Fix fast installation THS 55 | | \varnothing 10 x 6 | 9 088 070 | 50 ea. |

Fast assembly concealed hinge without integrated Silent System

- ▶ Sensys 8639 W30
- ▶ For 30° face angle, 95° opening angle



- ▶ Concealed hinge with clip on installation without integrated Silent System
- ▶ Quality classification under EN 15570, Level 3
- ▶ For diagonal base units, carcass angle 120°
- ▶ For door thickness 15 - 28 mm
- ▶ Cup diameter 35 mm
- ▶ Cup depth 12.8 mm
- ▶ Integrated overlay adjustment + 2 mm / - 2 mm
- ▶ Integrated depth adjustment + 3 mm / - 2 mm
- ▶ Height adjustment at mounting plate
- ▶ Hinge arm material: zinc die-cast nickel plated
- ▶ Hinge cup material: nickel plated steel

Sensys 8639 W30, opening angle 95°

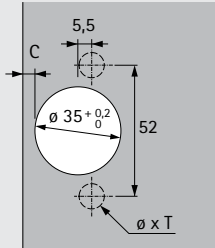
| | | | Overlay | |
|-----------------------|---|----------------------------------|---|--------|
| Cup assembly | Drilling pattern | Mounting hole \emptyset x T mm |  | PU |
| For screwing on TH 52 |  | - | 9 088 100 | 50 ea. |

Fast assembly concealed hinge

- ▶ Sensys 8639i W30 / Sensys 8639 W30
- ▶ For 30° face angle, 95° opening angle

Minimum reveal per door

| Door thickness mm | Cup distance C mm | | | | | | | |
|-------------------|-------------------|-----|-----|-----|-----|-----|-----|--|
| | 3.0 | 4.0 | 4.5 | 5.0 | 6.0 | 7.0 | 8.0 | |
| 15 | 0.2 | 0.2 | 0.2 | 0.2 | 0.2 | 0.2 | 0.2 | |
| 16 | 0.3 | 0.3 | 0.3 | 0.3 | 0.3 | 0.3 | 0.3 | |
| 17 | 0.4 | 0.4 | 0.4 | 0.4 | 0.4 | 0.4 | 0.4 | |
| 18 | 0.6 | 0.6 | 0.6 | 0.6 | 0.6 | 0.5 | 0.5 | |
| 19 | 0.8 | 0.8 | 0.8 | 0.8 | 0.7 | 0.7 | 0.7 | |
| 20 | 1.1 | 1.0 | 1.0 | 1.0 | 1.0 | 0.9 | 0.9 | |
| 21 | 1.4 | 1.3 | 1.3 | 1.3 | 1.2 | 1.2 | 1.2 | |
| 22 | 2.2 | 1.8 | 1.7 | 1.6 | 1.6 | 1.5 | 1.4 | |
| 23 | 3.0 | 2.6 | 2.4 | 2.2 | 2.0 | 1.9 | 1.8 | |
| 24 | 3.9 | 3.4 | 3.2 | 3.0 | 2.6 | 2.4 | 2.2 | |
| 25 | 4.8 | 4.2 | 4.0 | 3.8 | 3.4 | 3.0 | 2.8 | |
| 26 | 5.7 | 5.1 | 4.8 | 4.6 | 4.2 | 3.8 | 3.4 | |
| 27 | 6.6 | 6.0 | 5.7 | 5.5 | 5.0 | 4.5 | 4.2 | |
| 28 | 7.5 | 6.9 | 6.6 | 6.3 | 5.8 | 5.3 | 4.9 | |

Please note:

The table entries refer to doors with an edge radius of 1 mm.

On doors with other radii, the minimum reveal changes as follows:

Radius 0 mm:
Values shown in table + 0.4 mm

Radius 3 mm:
Values shown in table - 0.6 mm

Note

The drawings below show the hinges including mounting plate distances on a scale of 1:1. Allowing for cup distance C (3 - 8 mm) as well as the minimum reveal, the required mounting plate distance and hole line can be determined by drawing in the door and side panel.

You can visit our Hettich channel on YouTube for further information on how to configure cabinets.

Overlay (B 2 mm) - Scale 1:1

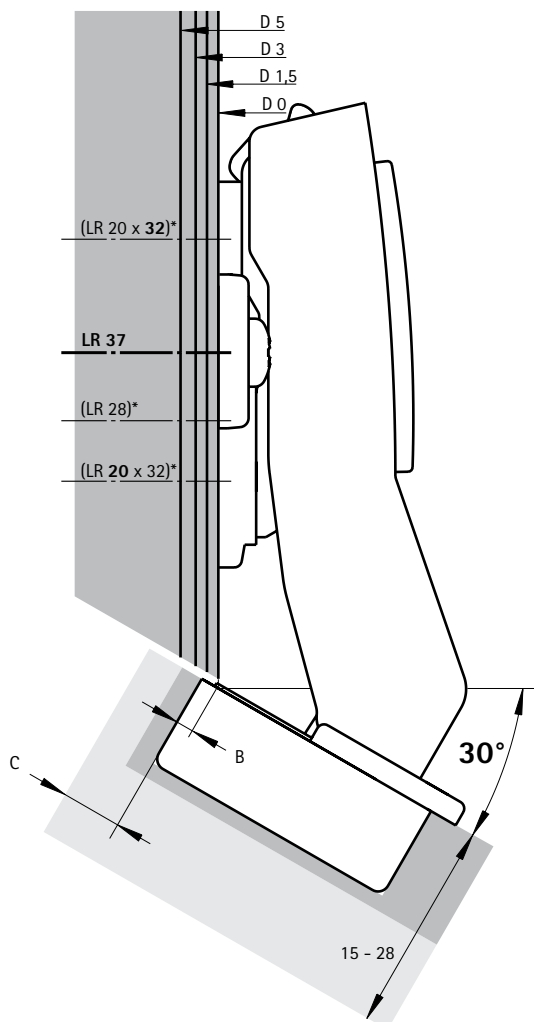

Advice

- ▶ For mounting plates and accessories, see page 90 - 97
- ▶ For example applications, fitting information, installation notes and quality criteria, see page 58 - 60

Fast assembly concealed hinge with integrated Silent System

- ▶ Sensys 8639i W45
- ▶ For 45° face angle, 95° opening angle



- ▶ Concealed hinge with clip on installation and integrated Silent System
- ▶ Quality classification under EN 15570, Level 3
- ▶ For diagonal base units, carcass angle 135°
- ▶ For door thickness 15 - 28 mm
- ▶ Cup diameter 35 mm
- ▶ Cup depth 12.8 mm
- ▶ Integrated overlay adjustment + 2 mm / - 2 mm
- ▶ Integrated depth adjustment + 3 mm / - 2 mm
- ▶ Height adjustment at mounting plate
- ▶ Hinge arm material: zinc die-cast nickel plated
- ▶ Hinge cup material: nickel plated steel

Sensys 8639i W45, opening angle 95°

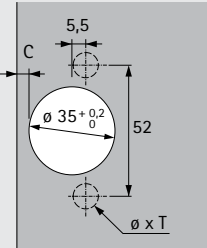
| | | | Overlay | |
|--|---|------------------------------------|---|------------------|
| Cup assembly | Drilling pattern | Mounting hole \varnothing x T mm |  | |
| For screwing on TH 52 |  | - | Basis B -2 mm | PU |
| For pressing in TH 53 | | \varnothing 10 x 11 | 9 088 019 | 50 ea. |
| Fix fast installation THS 55 | | \varnothing 10 x 6 | 9 088 037 | 50 ea. |
| With premounted expanding socket TH 58 | | \varnothing 10 x 11 | 9 088 073 | 9 088 085 |

Fast assembly concealed hinge with integrated Silent System

- ▶ Sensys 8639i W45 in obsidian black
- ▶ For 45° face angles, 95° opening angle



- ▶ Concealed hinge with clip on installation and integrated Silent System
- ▶ Quality classification under EN 15570, Level 3
- ▶ For diagonal cabinets, carcass angle 135°
- ▶ For door thickness of 15 - 28 mm
- ▶ Cup diameter 35 mm
- ▶ Cup depth 12.8 mm
- ▶ Integrated overlay adjustment + 2 mm / - 2 mm
- ▶ Integrated depth adjustment + 3 mm / - 2 mm
- ▶ Height adjustment at mounting plate
- ▶ All visible parts in obsidian black
- ▶ Hinge arm material: zinc die-cast in obsidian black
- ▶ Hinge cup material: steel in obsidian black

Sensys 8639i W45, 95° opening angle

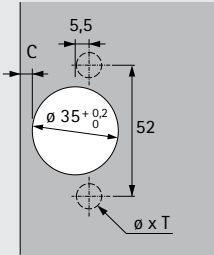
| Cup assembly | Drilling pattern | Mounting hole ø x T mm | Overlay  | PU |
|---|---|---------------------------|--|--------|
| For screwing on TH 52 |  | - | Base B -2 mm 9 091 747 | 50 ea. |
| With premounted expanding sockets TH 58 | | ø 10 x 11 | 9 091 779 | 50 ea. |

Fast assembly concealed hinge without integrated Silent System

- ▶ Sensys 8639 W45
- ▶ For 45° face angle, 95° opening angle



- ▶ Concealed hinge with clip on installation without integrated Silent System
- ▶ Quality classification under EN 15570, Level 3
- ▶ For diagonal base units, carcass angle 135°
- ▶ For door thickness 15 - 28 mm
- ▶ Cup diameter 35 mm
- ▶ Cup depth 12.8 mm
- ▶ Integrated overlay adjustment + 2 mm / - 2 mm
- ▶ Integrated depth adjustment + 3 mm / - 2 mm
- ▶ Height adjustment at mounting plate
- ▶ Hinge arm material: zinc die-cast nickel plated
- ▶ Hinge cup material: nickel plated steel

Sensys 8639 W45, opening angle 95°

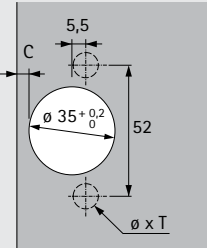
| Cup assembly | Drilling pattern | Mounting hole \varnothing x T mm | Overlay  | |
|------------------------------|---|------------------------------------|--|--------|
| For screwing on TH 52 |  | - | Basis B -2 mm | PU |
| Fix fast installation THS 55 | | $\varnothing 10 \times 6$ | | |
| | | | 9 088 103 | 50 ea. |
| | | | 9 088 139 | 50 ea. |

Fast assembly concealed hinge without self closing feature

- ▶ Sensys 8669 W45
- ▶ For 45° face angle, 95° opening angle



- ▶ Hinge with clip on installation without self closing feature
- ▶ For example for Push to open applications
- ▶ Quality classification under EN 15570, Level 3
- ▶ For diagonal base units, carcass angle 135°
- ▶ For door thickness 15 - 28 mm
- ▶ Cup diameter 35 mm
- ▶ Cup depth 12.8 mm
- ▶ Integrated overlay adjustment + 2 mm / - 2 mm
- ▶ Integrated depth adjustment + 3 mm / - 2 mm
- ▶ Height adjustment at mounting plate
- ▶ Hinge arm material: zinc die-cast nickel plated
- ▶ Hinge cup material: nickel plated steel

Sensys 8669 W45, opening angle 95°

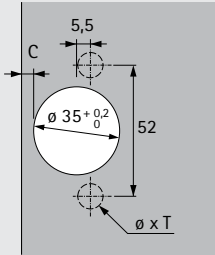
| Cup assembly | Drilling pattern | Mounting hole \emptyset x T mm | Overlay  | |
|------------------------------|---|----------------------------------|--|--------|
| For screwing on TH 52 |  | - | Basis B -2 mm | PU |
| Fix fast installation THS 55 | | $\emptyset 10 \times 6$ | | |
| | | | 9 088 179 | 50 ea. |
| | | | 9 088 215 | 50 ea. |

Fast assembly concealed hinge

- ▶ Sensys 8639i W45 / Sensys 8639 W45 / Sensys 8669 W45
- ▶ For 45° face angle, 95° opening angle

Minimum reveal per door

| Door thickness mm | Cup distance C mm | | | | | | |
|-------------------|-------------------|-----|-----|-----|-----|-----|-----|
| | 3.0 | 4.0 | 4.5 | 5.0 | 6.0 | 7.0 | 8.0 |
| 15 | 0.2 | 0.2 | 0.2 | 0.2 | 0.2 | 0.2 | 0.2 |
| 16 | 0.3 | 0.3 | 0.3 | 0.3 | 0.3 | 0.3 | 0.3 |
| 17 | 0.4 | 0.4 | 0.4 | 0.4 | 0.4 | 0.4 | 0.4 |
| 18 | 0.6 | 0.6 | 0.6 | 0.6 | 0.6 | 0.5 | 0.5 |
| 19 | 0.8 | 0.8 | 0.8 | 0.8 | 0.7 | 0.7 | 0.7 |
| 20 | 1.1 | 1.0 | 1.0 | 1.0 | 1.0 | 0.9 | 0.9 |
| 21 | 1.4 | 1.3 | 1.3 | 1.3 | 1.2 | 1.2 | 1.2 |
| 22 | 2.2 | 1.8 | 1.7 | 1.6 | 1.6 | 1.5 | 1.4 |
| 23 | 3.0 | 2.6 | 2.4 | 2.2 | 2.0 | 1.9 | 1.8 |
| 24 | 3.9 | 3.4 | 3.2 | 3.0 | 2.6 | 2.4 | 2.2 |
| 25 | 4.8 | 4.2 | 4.0 | 3.8 | 3.4 | 3.0 | 2.8 |
| 26 | 5.7 | 5.1 | 4.8 | 4.6 | 4.2 | 3.8 | 3.4 |
| 27 | 6.6 | 6.0 | 5.7 | 5.5 | 5.0 | 4.5 | 4.2 |
| 28 | 7.5 | 6.9 | 6.6 | 6.3 | 5.8 | 5.3 | 4.9 |

Please note:

The table entries refer to doors with an edge radius of 1 mm.

On doors with other radii, the minimum reveal changes as follows:

Radius 0 mm:
Values shown in table + 0.4 mm

Radius 3 mm:
Values shown in table - 0.6 mm

Note

The drawings below show the hinges including mounting plate distances on a scale of 1:1. Allowing for cup distance C (3 - 8 mm) as well as the minimum reveal, the required mounting plate distance and hole line can be determined by drawing in the door and side panel.

You can visit our Hettich channel on YouTube for further information on how to configure cabinets.

Overlay (B -2 mm) - Scale 1:1

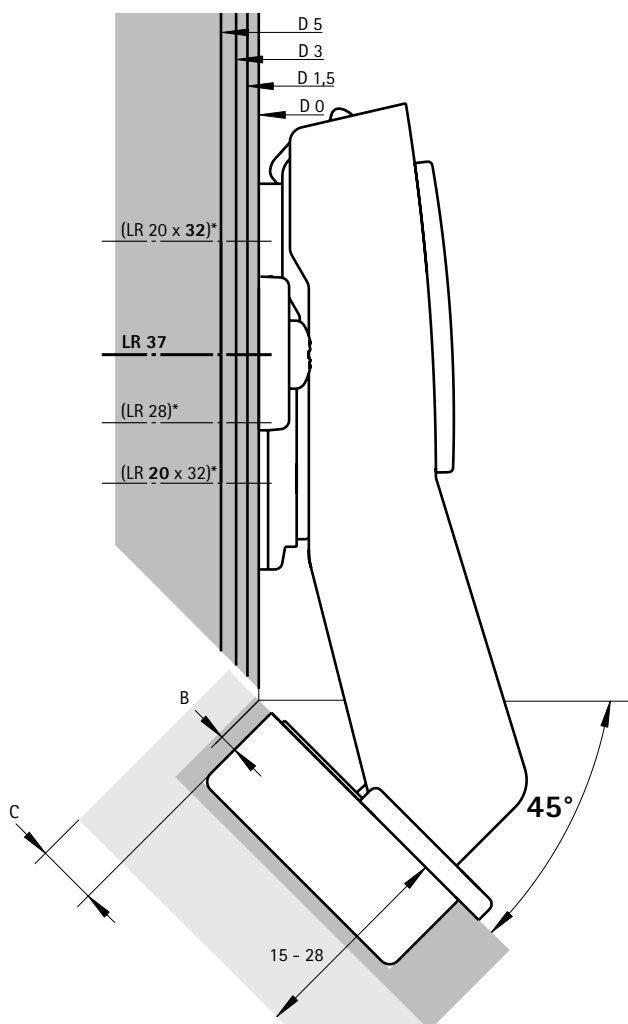

Advice

- ▶ For mounting plates and accessories, see page 90 - 97
- ▶ For example applications, fitting information, installation notes and quality criteria, see page 58 - 60

Fast assembly concealed hinge with integrated Silent System

- ▶ Sensys 8639i W90
- ▶ For 90° face angle, 95° opening angle



- ▶ Concealed hinge with clip on installation and integrated Silent System
- ▶ Quality classification under EN 15570, Level 2
- ▶ For corner cabinets
- ▶ For door thickness 15 - 28 mm
- ▶ Cup diameter 35 mm
- ▶ Cup depth 12.8 mm
- ▶ Integrated adjustment of door offset + 1 mm / - 2 mm
- ▶ Integrated reveal adjustment + 3 mm / - 2 mm
- ▶ Height adjustment at mounting plate
- ▶ Hinge arm material: zinc die-cast nickel plated
- ▶ Hinge cup material: nickel plated steel

Sensys 8639i W90, opening angle 95°

| Cup assembly | Drilling pattern | Mounting hole \varnothing x T mm | Inset | | |
|---|------------------|------------------------------------|-----------|-----------|--------|
| For screwing on TH 52 | | - | | PU | |
| For pressing in TH 53 | | \varnothing 10 x 11 | | 9 088 021 | 50 ea. |
| Fix fast installation THS 55 | | \varnothing 10 x 6 | | 9 088 039 | 50 ea. |
| With premounted expanding sockets TH 58 | | \varnothing 10 x 11 | | 9 088 075 | 50 ea. |
| Flash fast installation TH 54 | | \varnothing 10 x 11 | | 9 088 087 | 50 ea. |
| | | \varnothing 10 x 11 | 9 088 057 | 50 ea. | |

Fast assembly concealed hinge with integrated Silent System

- ▶ Sensys 8639i W90 in obsidian black
- ▶ For 90° face angles, 95° opening angle



- ▶ Concealed hinge with clip on installation and integrated Silent System
- ▶ Quality classification under EN 15570, Level 2
- ▶ For corner cabinets
- ▶ For door thickness of 15 - 28 mm
- ▶ Cup diameter 35 mm
- ▶ Cup depth 12.8 mm
- ▶ Integrated adjustment of door offset + 1 mm / - 2 mm
- ▶ Integrated reveal adjustment + 3 mm / - 2 mm
- ▶ Height adjustment at mounting plate
- ▶ All visible parts in obsidian black
- ▶ Hinge arm material: zinc die-cast in obsidian black
- ▶ Hinge cup material: steel in obsidian black

Sensys 8639i W90, 95° opening angle

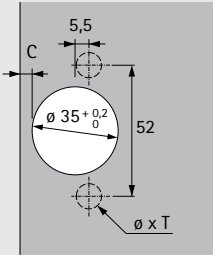
| Cup assembly | Drilling pattern | Mounting hole ø x T mm | Inset  Base B 4 mm | PU |
|---|---|---------------------------|---|--------|
| For screwing on TH 52 |  | - | 9 091 748 | 50 ea. |
| With premounted expanding sockets TH 58 | | ø 10 x 11 | 9 091 780 | 50 ea. |

Fast assembly concealed hinge without integrated Silent System

- ▶ Sensys 8639 W90
- ▶ For 90° face angle, 95° opening angle



- ▶ Concealed hinge with clip on installation without integrated Silent System
- ▶ Quality classification under EN 15570, Level 2
- ▶ For corner cabinets
- ▶ For door thickness 15 - 28 mm
- ▶ Cup diameter 35 mm
- ▶ Cup depth 12.8 mm
- ▶ Integrated adjustment of door offset + 1 mm / - 2 mm
- ▶ Integrated reveal adjustment + 3 mm / - 2 mm
- ▶ Height adjustment at mounting plate
- ▶ Hinge arm material: zinc die-cast nickel plated
- ▶ Hinge cup material: nickel plated steel

Sensys 8639 W90, opening angle 95°

| | | | Inset | |
|---|------------------|------------------------------------|------------------|--------|
| Cup assembly | Drilling pattern | Mounting hole \varnothing x T mm | Basis B 4 mm | PU |
| For pressing in TH 53 | | \varnothing 10 x 11 | 9 088 123 | 50 ea. |
| Fix fast installation THS 55 | | \varnothing 10 x 6 | 9 088 141 | 50 ea. |
| With premounted expanding sockets TH 58 | | \varnothing 10 x 11 | 9 088 159 | 50 ea. |

Fast assembly concealed hinge without self closing feature

- ▶ Sensys 8669 W90
- ▶ For 90° face angle, 95° opening angle



- ▶ Hinge with clip on installation without self closing feature
- ▶ For example for Push to open applications
- ▶ Quality classification under EN 15570, Level 2
- ▶ For corner cabinets
- ▶ For door thickness 15 - 28 mm
- ▶ Cup diameter 35 mm
- ▶ Cup depth 12.8 mm
- ▶ Integrated adjustment of door offset + 1 mm / - 2 mm
- ▶ Integrated reveal adjustment + 3 mm / - 2 mm
- ▶ Height adjustment at mounting plate
- ▶ Hinge arm material: zinc die-cast nickel plated
- ▶ Hinge cup material: nickel plated steel

Sensys 8669 W90, opening angle 95°

| Cup assembly | Drilling pattern | Mounting hole \varnothing x T mm | Inset | |
|---|------------------|------------------------------------|------------------|------------------|
| For pressing in TH 53 | | \varnothing 10 x 11 | Basis B 4 mm | PU |
| Fix fast installation THS 55 | | \varnothing 10 x 6 | 9 088 199 | 50 ea. |
| With premounted expanding sockets TH 58 | | \varnothing 10 x 11 | 9 088 217 | 9 088 229 |

Fast assembly concealed hinge

- ▶ Sensys 8639i W90 / Sensys 8639 W90 / Sensys 8669 W90
- ▶ For 90° face angle, 95° opening angle

Minimum reveal per door

| Door thickness mm | Cup distance C mm | | | | | |
|-------------------|-------------------|-----|-----|-----|-----|-----|
| | 3.0 | 4.0 | 4.5 | 5.0 | 6.0 | 7.0 |
| 15 | 0.2 | 0.2 | 0.2 | 0.2 | 0.2 | 0.2 |
| 16 | 0.3 | 0.3 | 0.3 | 0.3 | 0.3 | 0.3 |
| 17 | 0.4 | 0.4 | 0.4 | 0.4 | 0.4 | 0.4 |
| 18 | 0.6 | 0.6 | 0.6 | 0.6 | 0.6 | 0.5 |
| 19 | 0.8 | 0.8 | 0.8 | 0.8 | 0.7 | 0.7 |
| 20 | 1.1 | 1.0 | 1.0 | 1.0 | 1.0 | 0.9 |
| 21 | 1.4 | 1.3 | 1.3 | 1.3 | 1.2 | 1.2 |
| 22 | 2.2 | 1.8 | 1.7 | 1.6 | 1.6 | 1.5 |
| 23 | 3.0 | 2.6 | 2.4 | 2.2 | 2.0 | 1.9 |
| 24 | 3.9 | 3.4 | 3.2 | 3.0 | 2.6 | 2.4 |
| 25 | 4.8 | 4.2 | 4.0 | 3.8 | 3.4 | 3.0 |
| 26 | 5.7 | 5.1 | 4.8 | 4.6 | 4.2 | 3.8 |
| 27 | 6.6 | 6.0 | 5.7 | 5.5 | 5.0 | 4.5 |
| 28 | 7.5 | 6.9 | 6.6 | 6.3 | 5.8 | 5.3 |

Please note:

The table entries refer to doors with an edge radius of 1 mm.

On doors with other radii, the minimum reveal changes as follows:

Radius 0 mm:
Values shown in table + 0.4 mm

Radius 3 mm:
Values shown in table - 0.6 mm

Note

Calculation of required mounting plate distance D and hole line distance X to be observed:
Depending on the required door offset, cup distance C (3 - 7 mm) and reveal F, the dimensions can be seen in the drawing or table below.

The values stated for the hole line distance X apply when using a cross mounting plate for hole line 37.

Hole line distance X must be adjusted when using other mounting plates.

- LR 28: X - 9 mm
- LR 20 x 32: X - 17 mm / X + 15 mm

A door offset of 1 mm is recommended. Door offset can subsequently be corrected with the adjusting screw.

Determining hole line distance X mm when using mounting plate for hole line 37

| Reveal mm | Cup distance C mm | | | | | | | |
|-----------|-------------------|------|------|------|------|------|------|------|
| | 3.0 | 3.5 | 4.0 | 4.5 | 5.0 | 5.5 | 6.0 | 7.0 |
| 0.5 | 35.0 | 34.5 | 34.0 | 33.5 | 33.0 | 32.5 | 32.0 | 31.0 |
| 1.5 | 34.0 | 33.5 | 33.0 | 32.5 | 32.0 | 31.5 | 31.0 | 30.0 |
| 2.5 | 33.0 | 32.5 | 32.0 | 31.5 | 31.0 | 30.5 | 30.0 | 29.0 |
| 3.5 | 32.0 | 31.5 | 31.0 | 30.5 | 30.0 | 29.5 | 29.0 | 28.0 |
| 4.5 | 31.0 | 30.5 | 30.0 | 29.5 | 29.0 | 28.5 | 28.0 | 27.0 |
| 5.5 | 30.0 | 29.5 | 29.0 | 28.5 | 28.0 | 27.5 | 27.0 | 26.0 |
| 6.5 | 29.0 | 28.5 | 28.0 | 27.5 | 27.0 | 26.5 | 26.0 | 25.0 |
| 7.5 | 28.0 | 27.5 | 27.0 | 26.5 | 26.0 | 25.5 | 25.0 | 24.0 |

Inset (B 4 mm) - Scale 1:1

Distance D = 4 mm - door offset
(the recommended door offset equals 1 mm)

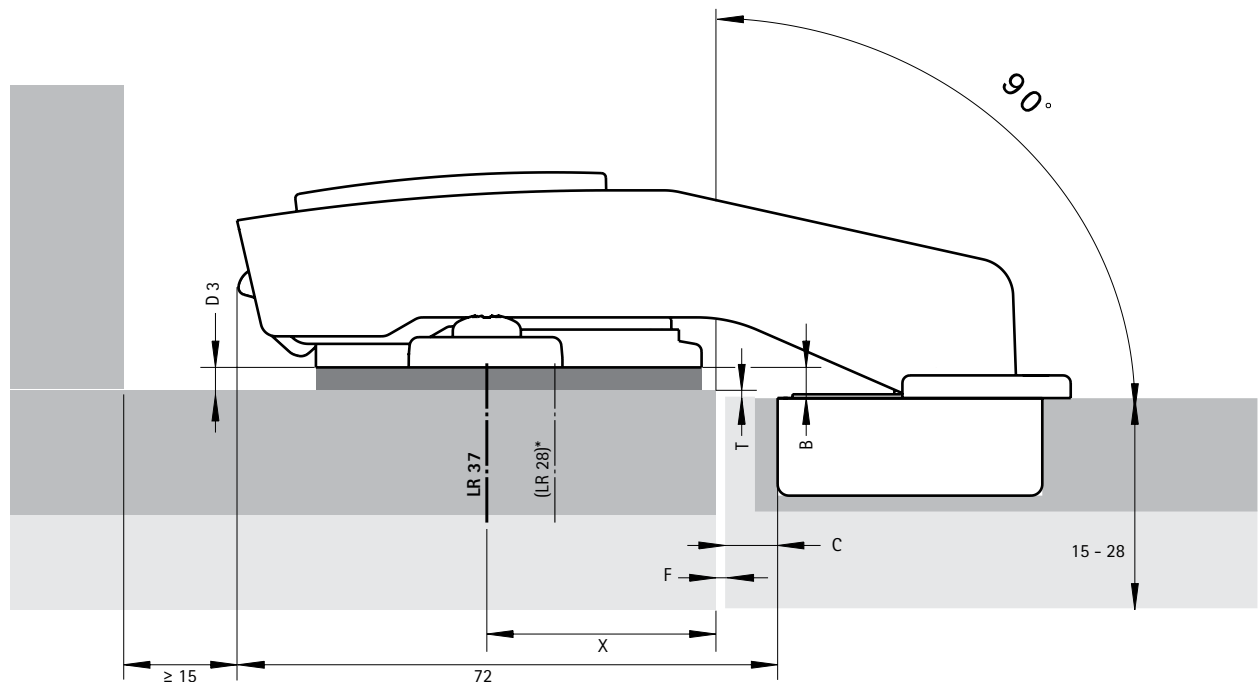

Advice

- ▶ For mounting plates and accessories, see page 90 - 97
- ▶ For example applications, fitting information, installation notes and quality criteria, see page 58 - 60

Fast assembly concealed hinge with integrated Silent System

- ▶ Sensys 8638i for aluminium framed doors
- ▶ 95° opening angle



- ▶ Concealed hinge with clip on installation and integrated Silent System
- ▶ Quality classification under EN 15570, Level 3
- ▶ For 19 mm wide aluminium framed profiles
- ▶ Integrated overlay adjustment + 2 mm / - 2 mm
- ▶ Integrated depth adjustment + 3 mm / - 2 mm
- ▶ Height adjustment at mounting plate
- ▶ Hinge arm material: nickel plated steel
- ▶ Cup hinge material: zinc die-cast nickel plated
- ▶ Including 2 fixing screws

Sensys 8638i, opening angle 95°

| | | Full overlay | Half overlay | Inset | |
|-----------------------|---|------------------|------------------|------------------|--------|
| | | | | | |
| Cup assembly | Mounting hole $\varnothing \times T$ mm | Base B 12,5 mm | Base B 3 mm | Base B -4 mm | PU |
| For screwing on TA 32 | - | 9 072 524 | 9 072 525 | 9 072 526 | 50 ea. |

- ▶ Sensys 8638i for aluminium framed doors in obsidian black
- ▶ 95° opening angle



- ▶ Concealed hinge with clip on installation and integrated Silent System
- ▶ Quality classification under EN 15570, Level 3
- ▶ For 19 mm wide aluminium framed profiles
- ▶ Integrated overlay adjustment + 2 mm / - 2 mm
- ▶ Integrated depth adjustment + 3 mm / - 2 mm
- ▶ Height adjustment at mounting plate
- ▶ All visible parts in obsidian black
- ▶ Hinge arm material: zinc die-cast in obsidian black
- ▶ Hinge cup material: steel in obsidian black
- ▶ Including 2 fixing screws

Sensys 8638i, opening angle 95°

| | | Full overlay | |
|-----------------------|---|------------------|----|
| | | | |
| Cup assembly | Mounting hole $\varnothing \times T$ mm | Base B 12,5 mm | PU |
| For screwing on TA 32 | - | 9 091 744 | |

Fast assembly concealed hinge

- ▶ Intermat 9930 with cup in Sensys design for corner cabinet folding doors
- ▶ 50° / 65° opening angle



- ▶ Concealed hinge with clip on installation
- ▶ Quality classification under EN 15570, Level 2
- ▶ Cup diameter 35 mm
- ▶ Cup depth 12.8 mm
- ▶ Diagonal adjustment + 9.5 mm / - 9.5 mm
- ▶ Integrated overlay adjustment, see sketch
- ▶ For integrated height adjustment, see sketch
- ▶ Height adjustment at mounting plate
- ▶ Hinge arm material: zinc die-cast nickel plated
- ▶ Hinge cup material: nickel plated steel

Intermat 9930, opening angle 50° / 65°

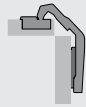
| | | | | |
|--------------|------------------|------------------------------------|---|----|
| | | | Overlay | |
| | | |  | |
| Cup assembly | Drilling pattern | Mounting hole \varnothing x T mm | Basis B 24 mm | PU |

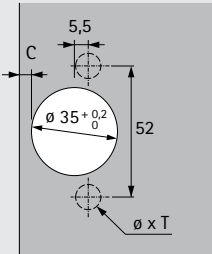
| | | | | |
|---|---|-----------------------|------------------|--------|
| For screwing on TH 52 |  | - | 9 090 109 | 50 ea. |
| For pressing in TH 53 | | \varnothing 10 x 11 | 9 090 110 | 50 ea. |
| Fix fast installation THS 55 | | \varnothing 10 x 6 | 9 090 113 | 50 ea. |
| With premounted expanding sockets TH 58 | | \varnothing 10 x 11 | 9 090 107 | 50 ea. |
| Flash fast installation TH 54 | | \varnothing 10 x 11 | 9 090 111 | 50 ea. |

Fast assembly concealed hinge

- ▶ Intermat 9930 with cup in Sensys design for corner cabinet folding doors in obsidian black
- ▶ 50° / 65° opening angle



- ▶ Concealed hinge with clip on installation
- ▶ Quality classification under EN 15570, Level 2
- ▶ Cup diameter 35 mm
- ▶ Cup depth 12.8 mm
- ▶ Diagonal adjustment + 9.5 mm / - 9.5 mm
- ▶ Integrated overlay adjustment, see sketch
- ▶ For integrated height adjustment, see sketch
- ▶ Height adjustment at mounting plate
- ▶ All visible parts in obsidian black
- ▶ Hinge arm material: zinc die-cast in obsidian black
- ▶ Hinge cup material: steel in obsidian black

Intermat 9930, opening angle 50° / 65°

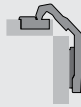
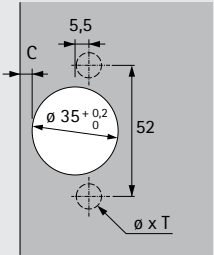
| Cup assembly | Drilling pattern | Mounting hole \varnothing x T mm | Overlay  | |
|---|---|------------------------------------|--|--------|
| For screwing on TH 52 |  | - | Basis B 24 mm | PU |
| With premounted expanding sockets TH 58 | | $\varnothing 10 \times 11$ | 9 116 398 | 50 ea. |

Fast assembly concealed hinge

- ▶ **Intermat 9930 with cup in Sensys design for corner cabinet folding doors**
- ▶ **50° / 65° opening angle**

Version A - Cup drill holes in one door

- ▶ All cup drillings in one door
- ▶ Hairline reveal can be provided between door units
- ▶ No cutaway in cup holes necessary
- ▶ Same door width for both elements
- ▶ Diagonal adjustment capability for easy adjustment to door thickness
- ▶ Same cup distance on both sides of side mounted door
- ▶ Hole line distance of 37 mm in the folding door panel
- ▶ For door thickness 16 - 21 mm
- ▶ Cup distance C 3 - 6 mm

Version B - Cup drill holes in both doors

- ▶ Both door units are the same
- ▶ No cutaway in cup holes necessary
- ▶ Diagonal adjustment capability for easy adjustment to door thickness
- ▶ Hole line distance of 41 mm in the side mounted door
- ▶ For door thickness 16 - 21 mm
- ▶ Cup distance C 3 - 6 mm

Version A - Calculation of door width

Door width = carcase width - reveal F - door thickness

Version B - Calculation of door width

Door width = carcase width - reveal F - door thickness - 5 mm

Version A - Calculation of mounting plate distance

For cup distance C = 4.5 mm: Distance D = 0 mm
For cup distance C = 3.0 mm: Distance D = 1.5 mm

Differing cup distances can be evened out by depth and diagonal adjustment capability.

Version B - Calculation of mounting plate distance

For cup distance C = 4.5 mm: Distance D = 0 mm
For cup distance C = 3.0 mm: Distance D = 1.5 mm

Differing cup distances can be evened out by depth and diagonal adjustment capability.

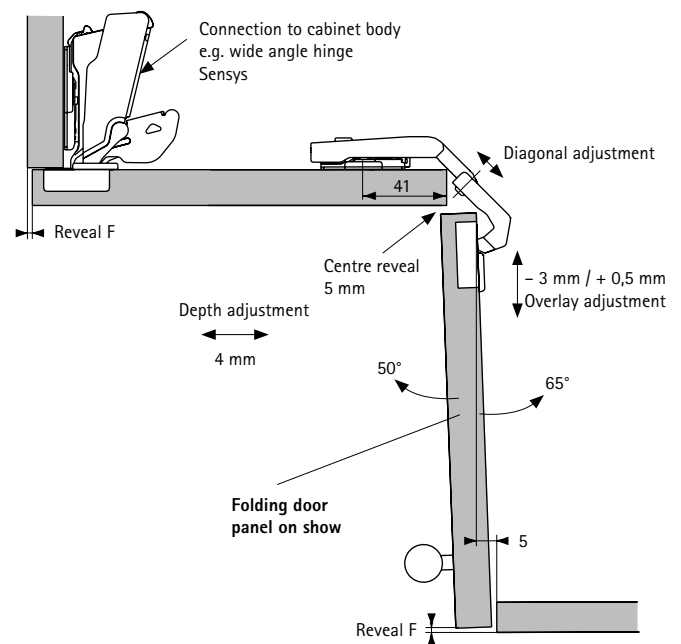
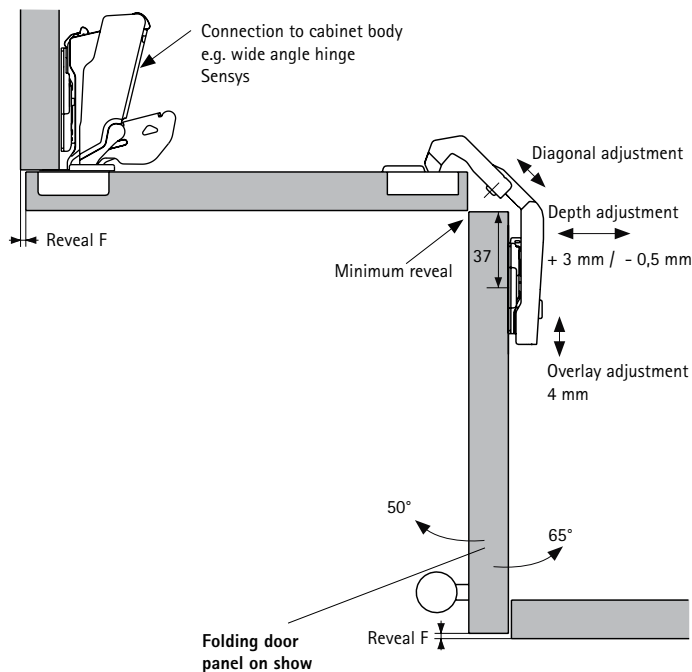

Advice

For mounting plates and accessories, see page 90 - 97

For mounting solutions, fitting information, installation notes and quality criteria, see page 58 - 60

Technical information

- ▶ Sensys
- ▶ Fitting information

Full overlay door

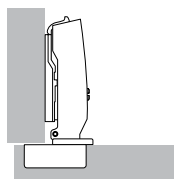

The door is in front of the carcass side and only a small gap remains at the side within which the door can open reliably. Alternatively, the door can also be overlaid fully. In this case sufficient space must be allowed at the side for the required minimum reveal. Straight hinges are used.

Half overlay door

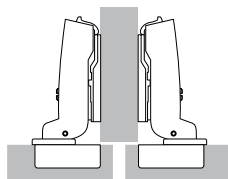

This is where two doors are positioned in front of a cabinet centre panel, with the required overall reveal between them (at least 2 x minimum reveal). In other words, each door has a smaller overlay and cranked hinges are therefore used.

Inset door

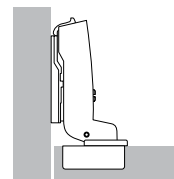

The door is positioned inside the carcass, i.e. next to the carcass side. Here too, a gap is needed so that the door can open reliably. Highly cranked hinges are used here. For an inset door, the mounting plate must be set back by the door thickness + 1 mm as well as by any any chosen door offset.

Minimum reveal

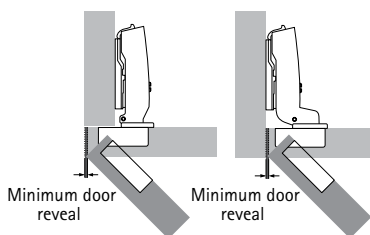

For full overlay and inset doors

The minimum reveal (also known as the door clearance or minimum clearance) is the space required at the side so that the door can open. The size of the minimum reveal depends on the cup distance C, the door thickness and the type of hinge selected. Radii on the door edges reduce the door clearance. The minimum reveal is shown in the table for the respective hinge types.

Minimum reveal

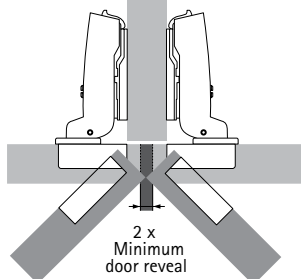

For half overlay doors

The total reveal selected between the doors must be at least twice the door clearance. Both doors can then be opened at the same time.

Cup distance C

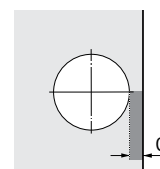

Cup distance C is the distance between the door edge and the edge of the cup drilling. The greater the distance selected for cup distance C, the smaller door clearance will be, i.e. the minimum reveal required.

Overlay / Base

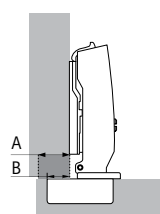

A = Overlay
B = Base

Overlay refers to the projection of the door in front of the carcass side. Base refers to the projection of the cup in front of the carcass side for a mounting plate distance of 0 mm.

Number of hinges per door

Door width, height and weight as well as the material quality of the door are decisive factors determining the number of hinges required.

The factors encountered in practice differ widely from case to case. For this reason, the number of hinges specified in the diagram must be understood as a guide only. If in doubt, it is recommended to carry out a trial mounting and adjust the number of hinges as necessary. For reasons of stability, space X between the hinges must always be made as large as possible. The space X must be at least 280 mm.

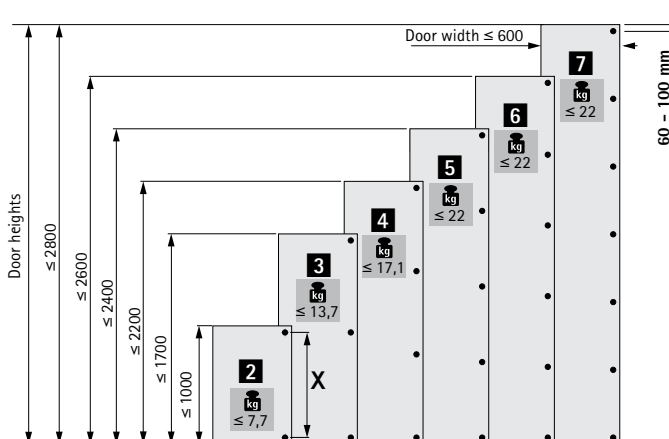

Technical information

- ▶ Sensys
- ▶ Fitting information

General calculation of distances

Mounting plates are available in various distances. The effective height of the mounting plate is defined by distance D. Distance D is embossed on the top of each mounting plate. A larger distance D reduces overlay for full and half overlay applications. On inset doors, a larger distance D increases the door reveal. Before determining the required distance,

check whether the desired reveal is equal to or greater than the required minimum reveal. If the desired reveal is less than the required minimum reveal, the required minimum reveal can be reduced by increasing cup distance C or by producing radii on the door edges.

Calculation of distances

For full overlay and half overlay doors

The required distance D can be determined after checking the minimum reveal. Ideally, the door reveal and cup distance should be selected to produce a distance D that is available as mounting plate.

Example: Working out distances according to the table

Overlay = 14 mm and cup distance C = 4.5 mm yield a distance D equal to 3.0 mm.

Example: Working out distances using the calculation formula

Hinge for full overlay door, base B = 12.5 mm
 Distance D = Cup distance C + base B - overlay A
 Distance D = 4.5 mm + 12.5 mm - 14 mm = 3.0 mm

Intermediate distances not available as mounting plate distances are achieved by adjusting the hinge overlay.

| Overlay mm | Cup distance C mm | | | | | |
|---------------|-------------------|-----|-----|-----|-----|-----|
| | 3,0 | 4,0 | 4,5 | 5,0 | 6,0 | 7,0 |
| | Distance D mm | | | | | |
| 10 | 5,5 | 6,5 | 7,0 | 7,5 | 8,5 | 9,5 |
| 11 | 4,5 | 5,5 | 6,0 | 6,5 | 7,5 | 8,5 |
| 12 | 3,5 | 4,5 | 5,0 | 5,5 | 6,5 | 7,5 |
| 13 | 2,5 | 3,5 | 4,0 | 4,5 | 5,5 | 6,5 |
| 14 | 1,5 | 2,5 | 3,0 | 3,5 | 4,5 | 5,5 |
| 15 | 0,5 | 1,5 | 2,0 | 2,5 | 3,5 | 4,5 |
| 16 | | 0,5 | 1,0 | 1,5 | 2,5 | 3,5 |
| 17 | | | 0,0 | 0,5 | 1,5 | 2,5 |
| 18 | | | | | 0,5 | 1,5 |
| 19 | | | | | | 0,5 |

Calculation of distances

For inset doors

When calculating the mounting plate distance using the table for the inset, allowance is automatically made for the reveal to be designated as the minimum reveal in relation to cup distance C and the door thickness in the minimum reveal table. If a reveal is to be produced that is larger than this minimum reveal, select a mounting plate distance of the appropriate size.

Example: Working out distances according to the table

According to the table, a door thickness = 20 mm and cup distance C = 4.5 mm produce a mounting plate distance of 1.5 mm. This gives the required minimum reveal, for example, of 1 mm. If a reveal of 2.5 mm is preferred instead, select a mounting plate distance which is 1.5 mm larger. In this example, therefore, a distance of 3 mm instead of 1.5 mm.

Example: Working out distances using the calculation formula

Hinge for inset application, base value B = - 4 mm
 Distance D = cup distance C + base B + reveal F
 Distance D = 4.5 mm - 4 mm + 1 mm = 1.5 mm

Intermediate distances not available as mounting plate distances are achieved by adjusting the overlay adjustment of the hinge.

| Door thickness mm | Cup distance C mm | | | | | |
|----------------------|-------------------|-----|-----|-----|-----|-----|
| | 3,0 | 4,0 | 4,5 | 5,0 | 6,0 | 7,0 |
| | Distance D mm | | | | | |
| 15 | | 0,2 | 0,7 | 1,2 | 2,2 | 3,2 |
| 16 | | 0,3 | 0,8 | 1,3 | 2,3 | 3,3 |
| 17 | | 0,4 | 0,9 | 1,4 | 2,4 | 3,4 |
| 18 | | 0,6 | 1,1 | 1,6 | 2,6 | 3,5 |
| 19 | | 0,8 | 1,3 | 1,8 | 2,7 | 3,7 |
| 20 | 0,1 | 1,0 | 1,5 | 2,0 | 3,0 | 3,9 |
| 21 | 0,4 | 1,3 | 1,8 | 2,3 | 3,2 | 4,2 |
| 22 | 1,2 | 1,8 | 2,2 | 2,6 | 3,6 | 4,5 |

Quality criteria

► Concealed hinges

Quality that meets all the demands

Quality that meets all the demands

The quality of hinges is subject to a process of continuous monitoring. Hettich fittings comply with the national and international quality standards of the markets our customers operate in. The diagrams below show examples of the principles behind some of the testing processes.

Application

Hettich hinges can be used in living room, kitchen, bathroom and office furniture.

Load capacity

The quality levels indicated on products comply with the requirements of EN 15570 and satisfy the overload tests at the specified level. We will be pleased to provide any further information you may require.

Corrosion test

Hettich hinges satisfy the corrosion requirements under EN ISO 9227-2012 in accordance with the 48 h neutral salt spray test (NSS) as well as DIN EN ISO 6270-2-2012 in accordance with the 96 h alternating condensation water climate test with alternating air humidity and temperature (AHT).

Quality assurance

The processes for assuring the quality of Hettich hinges are certified under EN ISO 9001, Cert. No. DE8000209.

Endurance test

The door is subjected to a specific number of opening and closing cycles.

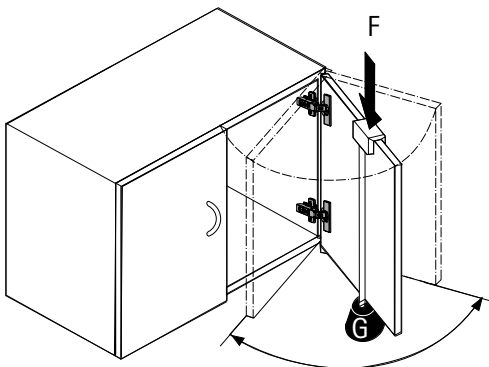

Closing test

The door is opened by 30° and pushed closed from this position by means of a pulley and falling weight.

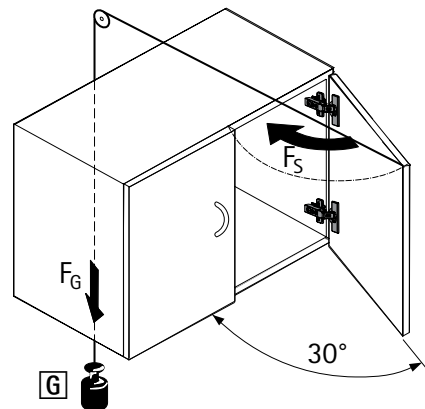

Horizontal test

The door is over opened with a defined test force F. (This test only applies to hinges with an opening angle < 135°.)

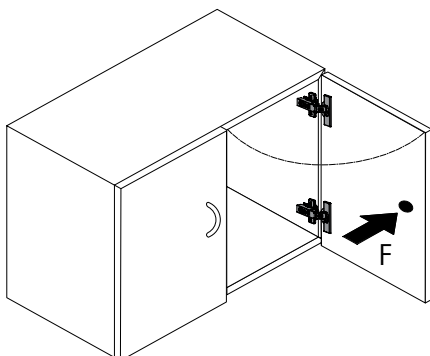

Vertical test

The door is subjected to a specific number of opening and closing cycles under a defined additional load G.

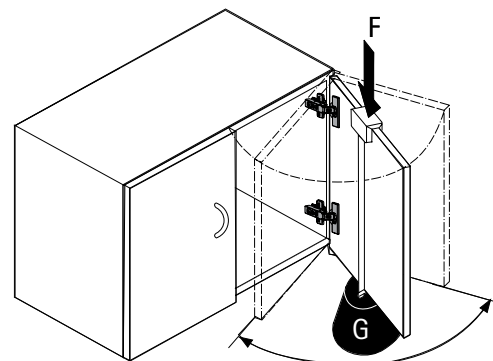

Concealed hinges

► Intermat fast assembly concealed hinge



Sound quality from the service focused partner: Intermat

Anyone opting for Interimat hinges also benefits from the many advantages in a partnership with Hettich.

For example, from decades of experience and continuous product improvement, high delivery reliability as well as the fast availability of Hettich products as a result of our own subsidiaries across the globe.



Tried and proven in millions of applications: the right decision
Intermat gives you unbeatable value for money and top quality "Made in Germany".



Versatile and future proof
This give you flexibility in quickly meeting customer demands or new trends in furniture design.



Further sales potential for you
Differentiate between furniture ranges the simple way with different hinge functionalities and optional accessories.



Installation and setup: fast and secure
Ergonomic, concealed clip on installation for convenient fast installation with protection against accidental detachment.

Fast assembly concealed hinge

- ▶ **Intermat**
- ▶ **Range summary**



Intermat 110° standard hinge

- ▶ Intermat 9943 / 9973
- ▶ Opening angle 110°

64 - 66



Intermat 95° thick door hinge

- ▶ Intermat 9936
- ▶ For doors in thicknesses up to 32 mm

68 - 70



Intermat 95° special thick door hinge

- ▶ Intermat 9935
- ▶ For doors in thicknesses up to 43 mm

72 - 74



Sensys 165° zero protrusion hinge

- ▶ Sensys 8657 / 8687
- ▶ For unobstructed access to storage space

76 - 78



Intermat W45 angle hinge

- ▶ Intermat 9936 W45
- ▶ For face angle 45°

80 - 81



Intermat W90 angle hinge

- ▶ Intermat 9936 W90
- ▶ For 90° face angle applications

82 - 83



Intermat glass door hinge

- ▶ Intermat 9904
- ▶ For glass doors

84 - 85



Intermat corner unit hinge

- ▶ Intermat 9930
- ▶ For corner cabinet folding doors

86 - 87



Mounting plates System 8099

- ▶ For Sensys and Intermat

90 - 92



Accessories

- ▶ For Sensys/Intermat

93 - 97



Silent System

- ▶ Optional Silent System for Intermat

100 - 103

Fast assembly concealed hinge

- ▶ **Intermat 9943**
- ▶ **Opening angle 110°**



- ▶ Concealed hinge with clip on installation
- ▶ Quality classification under EN 15570, Level 3
- ▶ For door thickness 15 - 25 mm
- ▶ Cup diameter 35 mm
- ▶ Cup depth 11.6 mm
- ▶ Integrated overlay adjustment + 2 mm / - 2 mm
- ▶ Integrated depth adjustment + 2.5 mm / - 1.5 mm
- ▶ Height adjustment at mounting plate
- ▶ Hinge arm material: nickel plated steel
- ▶ Hinge cup material: nickel plated steel

Intermat 9943, opening angle 110°

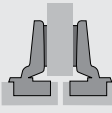
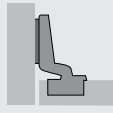
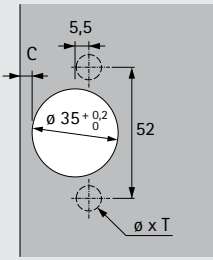
| Cup assembly | Drilling pattern | Mounting hole ϕ x T mm | Full overlay | Half overlay | Inset | PU |
|---|---|-----------------------------|---|---|---|---------|
| | | |  |  |  | |
| For screwing on TH 42 |  | - | Base B 12,5 mm | Base B 3 mm | Base B -3,5 mm | 200 ea. |
| For pressing in TH 43 | | ϕ 10 x 11 | 1 029 518 | 1 030 620 | 1 030 922 | 200 ea. |
| With premounted expanding sockets TH 48 | | ϕ 10 x 6 | 1 029 520 | 1 030 622 | 1 030 924 | 200 ea. |
| Flash fast installation TH 44 | | ϕ 10 x 11 | 9 043 640 | 9 043 641 | 9 043 642 | 200 ea. |
| | | | | 1 031 071 | | 200 ea. |
| | | | | 9 075 108 | 9 075 122 | 50 ea. |

Fast assembly concealed hinge without self closing feature

- ▶ **Intermat 9973**
- ▶ **Opening angle 110°**



- ▶ Hinge with clip on installation without self closing feature
- ▶ For example for Push to open applications
- ▶ Quality classification under EN 15570, Level 3
- ▶ For door thickness 15 - 25 mm
- ▶ Cup diameter 35 mm
- ▶ Cup depth 11.6 mm
- ▶ Integrated overlay adjustment + 2 mm / - 2 mm
- ▶ Integrated depth adjustment + 2.5 mm / - 1.5 mm
- ▶ Height adjustment at mounting plate
- ▶ Hinge arm material: nickel plated steel
- ▶ Hinge cup material: nickel plated steel

Intermat 9973, opening angle 110°

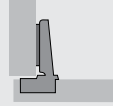
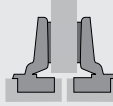
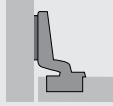
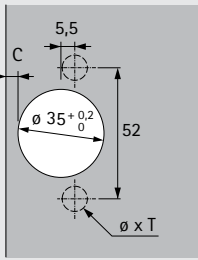
| Cup assembly | Drilling pattern | Mounting hole \varnothing x T mm | Full overlay | Half overlay | Inset | PU |
|---|---|------------------------------------|---|---|---|--------|
| | | |  |  |  | |
| For screwing on TH 42 |  | - | Base B 12,5 mm | Base B 3 mm | Base B -3,5 mm | 50 ea. |
| For pressing in TH 43 | | \varnothing 10 x 11 | 9 043 361 | 9 072 563 | | 50 ea. |
| With premounted expanding sockets TH 48 | | \varnothing 10 x 11 | 9 072 569 | 9 072 570 | 9 072 571 | 50 ea. |

- ▶ **Intermat 9943 / 9973**
- ▶ **Opening angle 110°**

Minimum reveal per door

| Door thickness mm | Cup distance C mm | | | | |
|-------------------|-------------------|-----|-----|-----|-----|
| | 3.0 | 4.0 | 4.5 | 5.0 | 6.0 |
| 15 | 0.4 | 0.4 | 0.4 | 0.4 | 0.4 |
| 16 | 0.6 | 0.5 | 0.5 | 0.5 | 0.5 |
| 17 | 0.8 | 0.7 | 0.7 | 0.7 | 0.7 |
| 18 | 1.0 | 1.0 | 1.0 | 1.0 | 0.9 |
| 19 | 1.4 | 1.3 | 1.3 | 1.2 | 1.2 |
| 20 | 1.7 | 1.7 | 1.6 | 1.6 | 1.5 |
| 21 | 2.2 | 2.1 | 2.0 | 2.0 | 1.9 |
| 22 | 2.9 | 2.6 | 2.5 | 2.4 | 2.3 |
| 23 | 3.7 | 3.3 | 3.2 | 3.0 | 2.8 |
| 24 | 4.5 | 4.1 | 3.9 | 3.7 | 3.4 |
| 25 | 5.4 | 4.9 | 4.7 | 4.5 | 4.1 |

Please note:

The table entries refer to doors with an edge radius of 1 mm.

On doors with other radii, the minimum reveal changes as follows:

Radius 0 mm:
Value in table + 0.4 mm

Radius 3 mm:
Value in table - 0.8 mm

Protrusions / installed depth

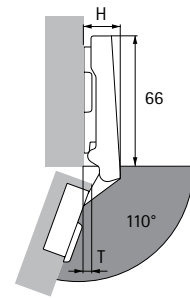

Hinge protrusion H / door protrusion T for distance D = 0 mm and cup distance C = 3 mm

| Door mounting option | H mm | T mm |
|----------------------|------|------|
| Full overlay | 19.5 | 7.5 |
| Half overlay | 29.0 | 17.0 |
| Inset | 35.5 | 23.5 |

Full overlay

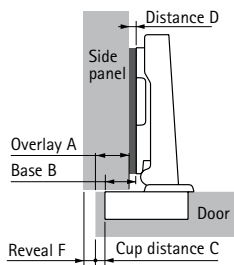

$$\text{Distance D} = C + B - A$$

$$= \text{cup distance C} + 12.5 \text{ mm} - \text{overlay A}$$

| Overlay mm | Cup distance C mm | | | | |
|---------------|-------------------|-----|-----|-----|-----|
| | 3.0 | 4.0 | 4.5 | 5.0 | 6.0 |
| Distance D mm | | | | | |
| 10 | 5.5 | 6.5 | 7.0 | 7.5 | 8.5 |
| 11 | 4.5 | 5.5 | 6.0 | 6.5 | 7.5 |
| 12 | 3.5 | 4.5 | 5.0 | 5.5 | 6.5 |
| 13 | 2.5 | 3.5 | 4.0 | 4.5 | 5.5 |
| 14 | 1.5 | 2.5 | 3.0 | 3.5 | 4.5 |
| 15 | 0.5 | 1.5 | 2.0 | 2.5 | 3.5 |
| 16 | | 0.5 | 1.0 | 1.5 | 2.5 |
| 17 | | | 0.0 | 0.5 | 1.5 |
| 18 | | | | | 0.5 |

Half overlay

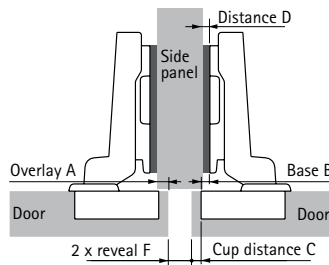

$$\text{Distance D} = C + B - A$$

$$= \text{cup distance C} + 3 \text{ mm} - \text{overlay A}$$

| Overlay mm | Cup distance C mm | | | | |
|---------------|-------------------|-----|-----|-----|-----|
| | 3.0 | 4.0 | 4.5 | 5.0 | 6.0 |
| Distance D mm | | | | | |
| 0.5 | 5.5 | 6.5 | 7.0 | 7.5 | 8.5 |
| 1.5 | 4.5 | 5.5 | 6.0 | 6.5 | 7.5 |
| 2.5 | 3.5 | 4.5 | 5.0 | 5.5 | 6.5 |
| 3.5 | 2.5 | 3.5 | 4.0 | 4.5 | 5.5 |
| 4.5 | 1.5 | 2.5 | 3.0 | 3.5 | 4.5 |
| 5.5 | 0.5 | 1.5 | 2.0 | 2.5 | 3.5 |
| 6.5 | | 0.5 | 1.0 | 1.5 | 2.5 |
| 7.5 | | | 0.0 | 0.5 | 1.5 |
| 8.5 | | | | | 0.5 |

Inset

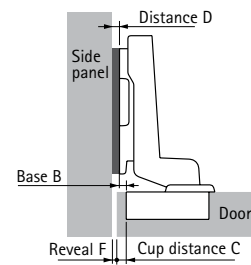

$$\text{Distance D} = C + B + F$$

$$= \text{cup distance C} - 3.5 \text{ mm} + \text{reveal F}$$

| Door thickness mm | Cup distance C mm | | | | |
|-------------------|-------------------|-----|-----|-----|-----|
| | 3.0 | 4.0 | 4.5 | 5.0 | 6.0 |
| Distance D mm | | | | | |
| 15 | 0.9 | 1.4 | 1.9 | 2.9 | |
| 16 | 0.1 | 1.0 | 1.5 | 2.0 | 3.0 |
| 17 | 0.3 | 1.2 | 1.7 | 2.2 | 3.2 |
| 18 | 0.5 | 1.5 | 2.0 | 2.5 | 3.4 |
| 19 | 0.9 | 1.8 | 2.3 | 2.7 | 3.7 |
| 20 | 1.2 | 2.2 | 2.6 | 3.1 | 4.0 |
| 21 | 1.7 | 2.6 | 3.0 | 3.5 | 4.3 |
| 22 | 2.4 | 3.1 | 3.5 | 3.9 | 4.8 |
| 23 | 3.2 | 3.8 | 4.2 | 4.5 | 5.3 |
| 24 | 4.0 | 4.6 | 4.9 | 5.2 | 5.9 |
| 25 | 4.9 | 5.4 | 5.7 | 6.0 | 6.6 |

Advice

- ▶ For mounting plates and accessories, see page 90 - 97
- ▶ For fitting information and quality criteria, see page 88 - 89

Fast assembly concealed hinge

- ▶ Intermat 9936 for doors in thicknesses up to 32 mm
- ▶ 95° opening angle



- ▶ Concealed hinge with clip on installation
- ▶ Quality classification under EN 15570, Level 2
- ▶ For door thickness 14 - 32 mm
- ▶ Cup diameter 35 mm
- ▶ Cup depth 10.5 mm
- ▶ Integrated overlay adjustment + 2 mm / - 2 mm
- ▶ Integrated depth adjustment + 2.5 mm / - 1.5 mm
- ▶ Height adjustment at mounting plate
- ▶ Hinge arm material: nickel plated steel
- ▶ Hinge cup material: nickel plated steel

Intermat 9936, opening angle 95°

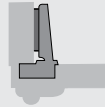
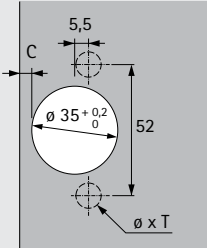
| Cup assembly | Drilling pattern | Mounting hole \varnothing x T mm | Full overlay  | PU | |
|---|---|------------------------------------|---|------------------|---------|
| For screwing on TH 42 |  | - | Base B 12,5 mm | 200 ea. | |
| For pressing in TH 43 | | $\varnothing 10 \times 11$ | 1 058 365 | 200 ea. | |
| With premounted expanding sockets TH 48 | | $\varnothing 10 \times 11$ | 1 058 371 | 200 ea. | |
| | | | | 9 043 629 | 200 ea. |

Fast assembly concealed hinge

- ▶ **Intermat 9936** for doors in thicknesses up to 32 mm
- ▶ **95° opening angle**

Minimum reveal per door

| Door thickness mm | Cup distance C mm | | | | | | |
|-------------------|-------------------|-----|-----|-----|-----|-----|-----|
| | 3.0 | 4.0 | 4.5 | 5.0 | 6.0 | 7.0 | 8.0 |
| 14 | 0.2 | 0.2 | 0.2 | 0.2 | 0.2 | 0.2 | 0.2 |
| 15 | 0.3 | 0.2 | 0.2 | 0.2 | 0.2 | 0.2 | 0.2 |
| 16 | 0.4 | 0.4 | 0.4 | 0.4 | 0.4 | 0.4 | 0.4 |
| 17 | 0.5 | 0.5 | 0.5 | 0.5 | 0.5 | 0.5 | 0.5 |
| 18 | 0.7 | 0.7 | 0.7 | 0.7 | 0.6 | 0.6 | 0.6 |
| 19 | 0.9 | 0.9 | 0.9 | 0.8 | 0.8 | 0.8 | 0.8 |
| 20 | 1.1 | 1.1 | 1.1 | 1.1 | 1.0 | 1.0 | 1.0 |
| 21 | 1.4 | 1.3 | 1.3 | 1.3 | 1.3 | 1.2 | 1.2 |
| 22 | 1.7 | 1.6 | 1.6 | 1.6 | 1.5 | 1.5 | 1.5 |
| 23 | 2.0 | 1.9 | 1.9 | 1.9 | 1.8 | 1.8 | 1.7 |
| 24 | 2.3 | 2.3 | 2.2 | 2.2 | 2.1 | 2.1 | 2.0 |
| 25 | 2.8 | 2.7 | 2.6 | 2.6 | 2.5 | 2.4 | 2.4 |
| 26 | 3.3 | 3.1 | 3.1 | 3.0 | 2.9 | 2.8 | 2.7 |
| 27 | 4.2 | 3.7 | 3.6 | 3.5 | 3.3 | 3.2 | 3.1 |
| 28 | 5.0 | 4.5 | 4.3 | 4.1 | 3.9 | 3.7 | 3.6 |
| 29 | 5.9 | 5.4 | 5.2 | 4.9 | 4.6 | 4.3 | 4.1 |
| 30 | 6.8 | 6.3 | 6.0 | 5.8 | 5.3 | 5.0 | 4.7 |
| 31 | 7.8 | 7.2 | 6.9 | 6.6 | 6.1 | 5.7 | 5.4 |
| 32 | 8.7 | 8.1 | 7.8 | 7.5 | 7.0 | 6.5 | 6.1 |

Please note:

The table entries refer to doors with an edge radius of 1 mm.

On doors with other radii, the minimum reveal changes as follows:

Radius 0 mm:
Value in table + 0.4 mm

Radius 3 mm:
Value in table - 0.8 mm

Protrusions / installed depth

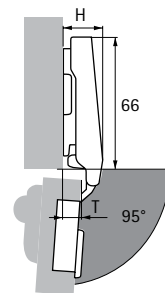

Hinge protrusion H / door protrusion T for distance D = 0 mm and cup distance C = 3 mm

| Door mounting option | H mm | T mm |
|----------------------|------|------|
| Full overlay | 19.5 | 10.0 |

Full overlay

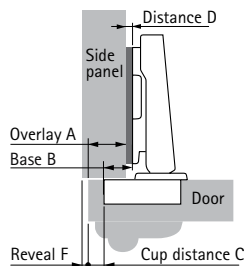

$$\text{Distance D} = \text{C} + \text{B} - \text{A}$$

= cup distance C + 12.5 mm - overlay A

| Overlay mm | Cup distance C mm | | | | | | |
|------------|-------------------|-----|-----|-----|-----|-----|------|
| | 3.0 | 4.0 | 4.5 | 5.0 | 6.0 | 7.0 | 8.0 |
| | Distance D mm | | | | | | |
| 10 | 5.5 | 6.5 | 7.0 | 7.5 | 8.5 | 9.5 | 10.5 |
| 11 | 4.5 | 5.5 | 6.0 | 6.5 | 7.5 | 8.5 | 9.5 |
| 12 | 3.5 | 4.5 | 5.0 | 5.5 | 6.5 | 7.5 | 8.5 |
| 13 | 2.5 | 3.5 | 4.0 | 4.5 | 5.5 | 6.5 | 7.5 |
| 14 | 1.5 | 2.5 | 3.0 | 3.5 | 4.5 | 5.5 | 6.5 |
| 15 | 0.5 | 1.5 | 2.0 | 2.5 | 3.5 | 4.5 | 5.5 |
| 16 | | 0.5 | 1.0 | 1.5 | 2.5 | 3.5 | 4.5 |
| 17 | | | 0.0 | 0.5 | 1.5 | 2.5 | 3.5 |
| 18 | | | | | 0.5 | 1.5 | 2.5 |
| 19 | | | | | | 0.5 | 1.5 |
| 20 | | | | | | | 0.5 |

Advice

- ▶ For mounting plates and accessories, see page 90 - 97
- ▶ For fitting information and quality criteria, see page 88 - 89

Fast assembly concealed hinge

- ▶ **Intermat 9936 for doors in thicknesses up to 32 mm**
- ▶ **95° opening angle**

Door contours for minimum reveal application - scale 1:1

The values shown in the Minimum reveal table refer to non-rounded door edges.
Reveal values improve with chamfered door edges. To obtain a minimum reveal application, the chosen door contour must lie within the template. All contours protruding beyond the template will increase the reveal accordingly.



Example of minimum reveal application

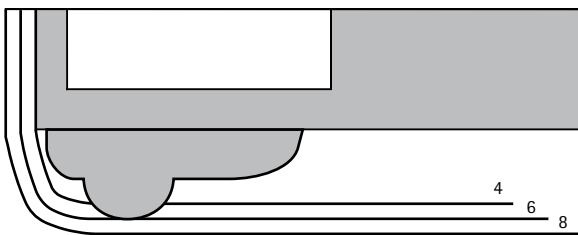

Example of minimum reveal application

| | |
|-------------------|-------|
| Door thickness | 16 mm |
| Profile thickness | 12 mm |
| Overall thickness | 28 mm |
| Cup distance C | 6 mm |

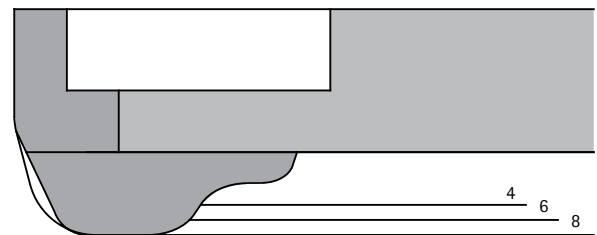

Example of minimum reveal application

| | |
|-------------------|-------|
| Door thickness | 19 mm |
| Profile thickness | 11 mm |
| Overall thickness | 30 mm |
| Cup distance C | 8 mm |

Fast assembly concealed hinge

- ▶ Intermat 9935 for doors in thicknesses up to 43 mm
- ▶ 95° opening angle



- ▶ Concealed hinge with clip on installation
- ▶ Quality classification under EN 15570, Level 2
- ▶ For door thickness 16 - 43 mm
- ▶ Cup diameter 40 mm
- ▶ Cup depth 13.7 mm
- ▶ Integrated overlay adjustment + 2 mm / - 2 mm
- ▶ Integrated depth adjustment + 2.5 mm / - 1.5 mm
- ▶ Height adjustment at mounting plate
- ▶ Hinge arm material: zinc die-cast nickel plated
- ▶ Cup hinge material: zinc die-cast nickel plated

Intermat 9935, opening angle 95°

| | | Full overlay | Half overlay | Inset | | |
|---------------------------|------------------|-----------------------------|--------------|-------------|--------------|--------|
| Cup assembly | Drilling pattern | Mounting hole ϕ x T mm | Base B 18 mm | Base B 8 mm | Base B -3 mm | PU |
| For screwing on TH 22 / L | | - | 9 117 716 | 9 117 717 | 9 117 718 | 10 ea. |

Fast assembly concealed hinge

- ▶ Intermat 9935 for doors in thicknesses up to 43 mm
- ▶ 95° opening angle

Minimum reveal per door

| Door thickness mm | Cup distance C mm | | | | | | | | | |
|-------------------|-------------------|------|------|------|------|-----|-----|-----|------|------|
| | 3.0 | 4.0 | 4.5 | 5.0 | 6.0 | 7.0 | 8.0 | 9.0 | 10.0 | 11.0 |
| 26 | 0.9 | 0.9 | 0.9 | 0.9 | 0.9 | 0.9 | 0.9 | 0.9 | 0.9 | 0.8 |
| 27 | 1.1 | 1.1 | 1.1 | 1.1 | 1.1 | 1.1 | 1.0 | 1.0 | 1.0 | 1.0 |
| 28 | 1.3 | 1.3 | 1.3 | 1.3 | 1.3 | 1.2 | 1.2 | 1.2 | 1.2 | 1.2 |
| 29 | 1.5 | 1.5 | 1.5 | 1.5 | 1.5 | 1.4 | 1.4 | 1.4 | 1.4 | 1.4 |
| 30 | 1.7 | 1.7 | 1.7 | 1.7 | 1.7 | 1.6 | 1.6 | 1.6 | 1.6 | 1.6 |
| 31 | 2.0 | 2.0 | 1.9 | 1.9 | 1.9 | 1.9 | 1.8 | 1.8 | 1.8 | 1.8 |
| 32 | 2.3 | 2.2 | 2.2 | 2.2 | 2.1 | 2.1 | 2.1 | 2.1 | 2.0 | 2.0 |
| 33 | 3.1 | 2.5 | 2.5 | 2.5 | 2.4 | 2.4 | 2.3 | 2.3 | 2.3 | 2.2 |
| 34 | 4.1 | 3.4 | 3.0 | 2.7 | 2.7 | 2.7 | 2.6 | 2.6 | 2.5 | 2.5 |
| 35 | 5.0 | 4.3 | 4.0 | 3.7 | 3.0 | 3.0 | 2.9 | 2.9 | 2.8 | 2.8 |
| 36 | 6.0 | 5.3 | 4.9 | 4.6 | 4.0 | 3.4 | 3.2 | 3.2 | 3.1 | 3.1 |
| 37 | 7.0 | 6.2 | 5.9 | 5.5 | 4.9 | 4.3 | 3.7 | 3.5 | 3.4 | 3.4 |
| 38 | 7.9 | 7.2 | 6.8 | 6.5 | 5.8 | 5.2 | 4.6 | 4.1 | 3.8 | 3.7 |
| 39 | 8.9 | 8.1 | 7.8 | 7.4 | 6.7 | 6.1 | 5.5 | 5.0 | 4.5 | 4.1 |
| 40 | 9.9 | 9.1 | 8.7 | 8.4 | 7.7 | 7.0 | 6.4 | 5.8 | 5.3 | 4.8 |
| 41 | 10.9 | 10.1 | 9.7 | 9.3 | 8.6 | 8.0 | 7.3 | 6.7 | 6.2 | 5.7 |
| 42 | 11.9 | 11.1 | 10.7 | 10.3 | 9.6 | 8.9 | 8.3 | 7.7 | 7.1 | 6.6 |
| 43 | 12.8 | 12.0 | 11.7 | 11.3 | 10.5 | 9.8 | 9.2 | 8.6 | 8.0 | 7.4 |

Please note:

The table entries refer to doors with an edge radius of 1 mm.

On doors with other radii, the minimum reveal changes as follows:

Radius 0 mm:
Value in table + 0.4 mm

Radius 3 mm:
Value in table - 0.8 mm

Protrusions / installed depth

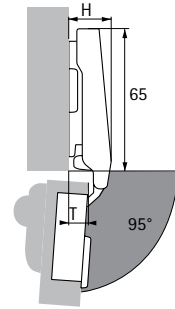

Hinge protrusion H / door protrusion T for distance D = 0 mm and cup distance C = 3 mm

| Door mounting option | H mm | T mm |
|----------------------|------|------|
| Full overlay | 20.0 | 10.5 |
| Half overlay | 30.0 | 20.5 |
| Inset | 41.0 | 31.5 |

Full overlay

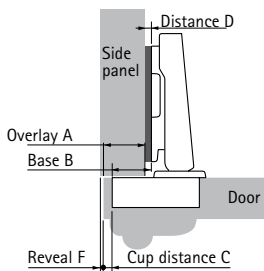

$$\text{Distance D} = \text{C} + \text{B} - \text{A}$$

$$= \text{cup distance C} + 18 \text{ mm} - \text{overlay A}$$

| Overlay mm | Cup distance C mm | | | | | | | | | |
|---------------|-------------------|------|------|------|------|------|------|------|------|------|
| | 3.0 | 4.0 | 4.5 | 5.0 | 6.0 | 7.0 | 8.0 | 9.0 | 10.0 | 11.0 |
| Distance D mm | | | | | | | | | | |
| 12 | 9.0 | 10.0 | 10.5 | 11.0 | 12.0 | 13.0 | 14.0 | 15.0 | 16.0 | 17.0 |
| 13 | 8.0 | 9.0 | 9.5 | 10.0 | 11.0 | 12.0 | 13.0 | 14.0 | 15.0 | 16.0 |
| 14 | 7.0 | 8.0 | 8.5 | 9.0 | 10.0 | 11.0 | 12.0 | 13.0 | 14.0 | 15.0 |
| 15 | 6.0 | 7.0 | 7.5 | 8.0 | 9.0 | 10.0 | 11.0 | 12.0 | 13.0 | 14.0 |
| 16 | 5.0 | 6.0 | 6.5 | 7.0 | 8.0 | 9.0 | 10.0 | 11.0 | 12.0 | 13.0 |
| 17 | 4.0 | 5.0 | 5.5 | 6.0 | 7.0 | 8.0 | 9.0 | 10.0 | 11.0 | 12.0 |
| 18 | 3.0 | 4.0 | 4.5 | 5.0 | 6.0 | 7.0 | 8.0 | 9.0 | 10.0 | 11.0 |
| 19 | 2.0 | 3.0 | 3.5 | 4.0 | 5.0 | 6.0 | 7.0 | 8.0 | 9.0 | 10.0 |
| 20 | 1.0 | 2.0 | 2.5 | 3.0 | 4.0 | 5.0 | 6.0 | 7.0 | 8.0 | 9.0 |
| 21 | 0.0 | 1.0 | 1.5 | 2.0 | 3.0 | 4.0 | 5.0 | 6.0 | 7.0 | 8.0 |
| 22 | | 0.0 | 0.5 | 1.0 | 2.0 | 3.0 | 4.0 | 5.0 | 6.0 | 7.0 |
| 23 | | | | 0.0 | 1.0 | 2.0 | 3.0 | 4.0 | 5.0 | 6.0 |
| 24 | | | | | 0.0 | 1.0 | 2.0 | 3.0 | 4.0 | 5.0 |
| 25 | | | | | | 0.0 | 1.0 | 2.0 | 3.0 | 4.0 |
| 26 | | | | | | | 0.0 | 1.0 | 2.0 | 3.0 |
| 27 | | | | | | | | 0.0 | 1.0 | 2.0 |
| 28 | | | | | | | | | 0.0 | 1.0 |
| 29 | | | | | | | | | | 0.0 |

Half overlay

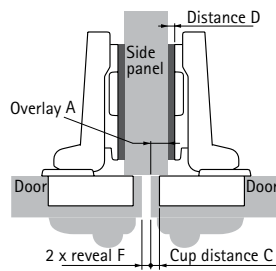

$$\text{Distance D} = \text{C} + \text{B} - \text{A}$$

$$= \text{cup distance C} + 8 \text{ mm} - \text{overlay A}$$

| Overlay mm | Cup distance C mm | | | | | | | | | |
|---------------|-------------------|------|------|------|------|------|------|------|------|------|
| | 3.0 | 4.0 | 4.5 | 5.0 | 6.0 | 7.0 | 8.0 | 9.0 | 10.0 | 11.0 |
| Distance D mm | | | | | | | | | | |
| 2 | 9.0 | 10.0 | 10.5 | 11.0 | 12.0 | 13.0 | 14.0 | 15.0 | 16.0 | 17.0 |
| 3 | 8.0 | 9.0 | 9.5 | 10.0 | 11.0 | 12.0 | 13.0 | 14.0 | 15.0 | 16.0 |
| 4 | 7.0 | 8.0 | 8.5 | 9.0 | 10.0 | 11.0 | 12.0 | 13.0 | 14.0 | 15.0 |
| 5 | 6.0 | 7.0 | 7.5 | 8.0 | 9.0 | 10.0 | 11.0 | 12.0 | 13.0 | 14.0 |
| 6 | 5.0 | 6.0 | 6.5 | 7.0 | 8.0 | 9.0 | 10.0 | 11.0 | 12.0 | 13.0 |
| 7 | 4.0 | 5.0 | 5.5 | 6.0 | 7.0 | 8.0 | 9.0 | 10.0 | 11.0 | 12.0 |
| 8 | 3.0 | 4.0 | 4.5 | 5.0 | 6.0 | 7.0 | 8.0 | 9.0 | 10.0 | 11.0 |
| 9 | 2.0 | 3.0 | 3.5 | 4.0 | 5.0 | 6.0 | 7.0 | 8.0 | 9.0 | 10.0 |
| 10 | 1.0 | 2.0 | 2.5 | 3.0 | 4.0 | 5.0 | 6.0 | 7.0 | 8.0 | 9.0 |
| 11 | 0.0 | 1.0 | 1.5 | 2.0 | 3.0 | 4.0 | 5.0 | 6.0 | 7.0 | 8.0 |
| 12 | | 0.0 | 0.5 | 1.0 | 2.0 | 3.0 | 4.0 | 5.0 | 6.0 | 7.0 |
| 13 | | | | 0.0 | 1.0 | 2.0 | 3.0 | 4.0 | 5.0 | 6.0 |
| 14 | | | | | 0.0 | 1.0 | 2.0 | 3.0 | 4.0 | 5.0 |
| 15 | | | | | | 0.0 | 1.0 | 2.0 | 3.0 | 4.0 |
| 16 | | | | | | | 0.0 | 1.0 | 2.0 | 3.0 |
| 17 | | | | | | | | 0.0 | 1.0 | 2.0 |
| 18 | | | | | | | | | 0.0 | 1.0 |
| 19 | | | | | | | | | | 0.0 |

Inset

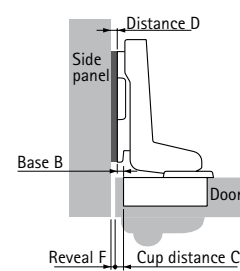

$$\text{Distance D} = \text{C} + \text{B} + \text{F}$$

$$= \text{cup distance C} - 3 \text{ mm} + \text{reveal F}$$

| Door thickness mm | Cup distance C mm | | | | | | | | | |
|-------------------|-------------------|------|------|------|------|------|------|------|------|------|
| | 3.0 | 4.0 | 4.5 | 5.0 | 6.0 | 7.0 | 8.0 | 9.0 | 10.0 | 11.0 |
| Distance D mm | | | | | | | | | | |
| 26 | 0.9 | 1.9 | 2.4 | 2.9 | 3.9 | 4.9 | 5.9 | 6.9 | 7.9 | 8.8 |
| 27 | 1.1 | 2.1 | 2.6 | 3.1 | 4.1 | 5.1 | 6.0 | 7.0 | 8.0 | 9.0 |
| 28 | 1.3 | 2.3 | 2.8 | 3.3 | 4.3 | 5.2 | 6.2 | 7.2 | 8.2 | 9.2 |
| 29 | 1.5 | 2.5 | 3.0 | 3.5 | 4.5 | 5.4 | 6.4 | 7.4 | 8.4 | 9.4 |
| 30 | 1.7 | 2.7 | 3.2 | 3.7 | 4.7 | 5.6 | 6.6 | 7.6 | 8.6 | 9.6 |
| 31 | 2.0 | 3.0 | 3.4 | 3.9 | 4.9 | 5.9 | 6.8 | 7.8 | 8.8 | 9.8 |
| 32 | 2.3 | 3.2 | 3.7 | 4.2 | 5.1 | 6.1 | 7.1 | 8.1 | 9.0 | 10.0 |
| 33 | 3.1 | 3.5 | 4.0 | 4.5 | 5.4 | 6.4 | 7.3 | 8.3 | 9.3 | 10.2 |
| 34 | 4.1 | 4.4 | 4.5 | 4.7 | 5.7 | 6.7 | 7.6 | 8.6 | 9.5 | 10.5 |
| 35 | 5.0 | 5.3 | 5.5 | 5.7 | 6.0 | 7.0 | 7.9 | 8.9 | 9.8 | 10.8 |
| 36 | 6.0 | 6.3 | 6.4 | 6.6 | 7.0 | 7.4 | 8.2 | 9.2 | 10.1 | 11.1 |
| 37 | 7.0 | 7.2 | 7.4 | 7.5 | 7.9 | 8.3 | 8.7 | 9.5 | 10.4 | 11.4 |
| 38 | 7.9 | 8.2 | 8.3 | 8.5 | 8.8 | 9.2 | 9.6 | 10.1 | 10.8 | 11.7 |
| 39 | 8.9 | 9.1 | 9.3 | 9.4 | 9.7 | 10.1 | 10.5 | 11.0 | 11.5 | 12.1 |
| 40 | 9.9 | 10.1 | 10.2 | 10.4 | 10.7 | 11.0 | 11.4 | 11.8 | 12.3 | 12.8 |
| 41 | 10.9 | 11.1 | 11.2 | 11.3 | 11.6 | 12.0 | 12.3 | 12.7 | 13.2 | 13.7 |
| 42 | 11.9 | 12.1 | 12.2 | 12.3 | 12.6 | 12.9 | 13.3 | 13.7 | 14.1 | 14.6 |
| 43 | 12.8 | 13.0 | 13.2 | 13.3 | 13.5 | 13.8 | 14.2 | 14.6 | 15.0 | 15.4 |

Advice

- ▶ For mounting plates and accessories, see page 90 - 97
- ▶ For fitting information and quality criteria, see page 88 - 89

Fast assembly concealed hinge

- ▶ Intermat 9935 for doors in thicknesses up to 43 mm
- ▶ 95° opening angle

Door contours for minimum reveal application - scale 1:1

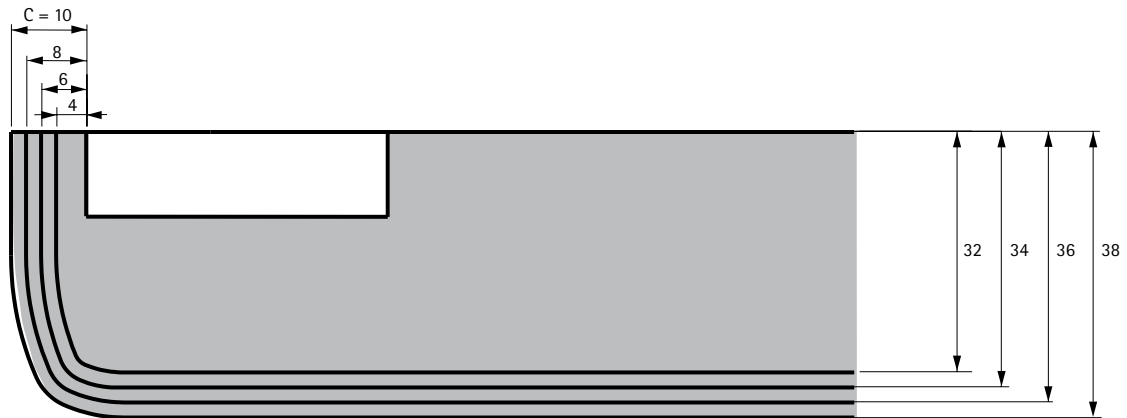

Example of minimum reveal application

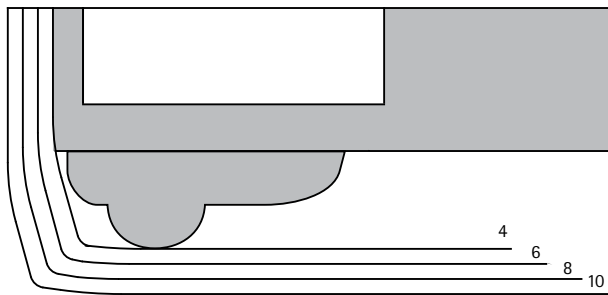

Example of minimum reveal application

| | |
|-------------------|-------|
| Door thickness | 19 mm |
| Profile thickness | 13 mm |
| Overall thickness | 32 mm |
| Cup distance C | 4 mm |

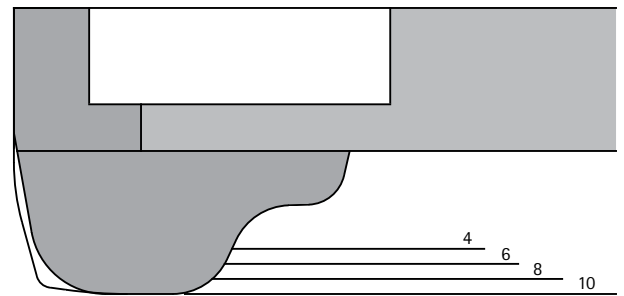

Example of minimum reveal application

| | |
|-------------------|-------|
| Door thickness | 19 mm |
| Profile thickness | 19 mm |
| Overall thickness | 38 mm |
| Cup distance C | 10 mm |



Fast assembly concealed hinge

- ▶ Sensys 8657 with cup in Intermat design, zero protrusion hinge
- ▶ Opening angle 165°



- ▶ Concealed hinge with clip on installation without integrated Silent System
- ▶ Quality classification under EN 15570, Level 3
- ▶ For door thickness of 15 – 32 mm
- ▶ Cup diameter 35 mm
- ▶ Cup depth 11.6 mm
- ▶ Integrated overlay adjustment + 2 mm / - 2 mm
- ▶ Integrated depth adjustment +3 mm / - 2 mm
- ▶ Height adjustment at mounting plate
- ▶ Opening angle can be reduced by means of optional accessories
- ▶ Zero protrusion hinge
- ▶ Hinge arm material: nickel plated steel
- ▶ Hinge cup material: nickel plated steel
- ▶ Note: can only be used with System 8099 mounting plate

Sensys 8657, opening angle 165°

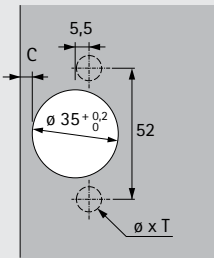
| Cup assembly | Drilling pattern | Mounting hole \varnothing x T mm | Full overlay | Half overlay | PU |
|---|---|------------------------------------|---|---|--------|
| | | |  |  | |
| For screwing on TH 42 |  | - | 9 099 750 | 9 099 760 | 50 ea. |
| For pressing in TH 43 | | \varnothing 10 x 11 | 9 099 751 | 9 099 761 | 50 ea. |
| Flash fast installation TH 44 | | \varnothing 10 x 11 | 9 099 752 | | 50 ea. |
| With premounted expanding sockets TH 48 | | \varnothing 10 x 11 | 9 099 756 | | 50 ea. |



Fast assembly concealed hinge without self closing feature

- ▶ Sensys 8687 with cup in Intermat design, zero protrusion hinge
- ▶ Opening angle 165°



- ▶ Hinge with clip on installation without self closing feature
- ▶ For example for Push to open applications
- ▶ Quality classification under EN 15570, Level 3
- ▶ For door thickness of 15 – 32 mm
- ▶ Cup diameter 35 mm
- ▶ Cup depth 11.6 mm
- ▶ Integrated overlay adjustment + 2 mm / - 2 mm
- ▶ Integrated depth adjustment + 3 mm / - 2 mm
- ▶ Height adjustment at mounting plate
- ▶ Opening angle can be reduced by means of optional accessories
- ▶ Zero protrusion hinge
- ▶ Hinge arm material: nickel plated steel
- ▶ Hinge cup material: nickel plated steel
- ▶ Note: can only be used with System 8099 mounting plate

Sensys 8687, opening angle 165°

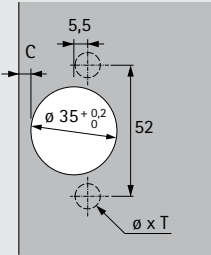
| Cup assembly | Drilling pattern | Mounting hole \varnothing x T mm | Full overlay | Half overlay | PU |
|---|---|------------------------------------|---|---|--------|
| | | |  |  | |
| For pressing in TH 43 |  | \varnothing 10 x 11 | Base B 12,5 mm 9 099 811 | Base B 3 mm 9 099 821 | 50 ea. |
| With premounted expanding sockets TH 48 | | \varnothing 10 x 11 | 9 099 816 | | 50 ea. |

Fast assembly concealed hinge

- ▶ Sensys 8657 / 8687 with cup in Intermat design, zero protrusion hinge
- ▶ Opening angle 165°

Minimum reveal per door

| Door thickness mm | Cup distance C mm | | | | | |
|-------------------|-------------------|-----|-----|-----|-----|-----|
| | 3.0 | 4.0 | 4.5 | 5.0 | 6.0 | 7.0 |
| 15 | 0.0 | 0.0 | 0.0 | 0.0 | 0.0 | 0.0 |
| 16 | 0.0 | 0.0 | 0.0 | 0.0 | 0.0 | 0.0 |
| 17 | 0.0 | 0.0 | 0.0 | 0.0 | 0.0 | 0.0 |
| 18 | 0.0 | 0.0 | 0.0 | 0.0 | 0.0 | 0.0 |
| 19 | 0.0 | 0.0 | 0.0 | 0.0 | 0.0 | 0.0 |
| 20 | 0.0 | 0.0 | 0.0 | 0.0 | 0.0 | 0.0 |
| 21 | 0.0 | 0.0 | 0.0 | 0.0 | 0.0 | 0.0 |
| 22 | 0.0 | 0.0 | 0.0 | 0.0 | 0.0 | 0.0 |
| 23 | 0.0 | 0.0 | 0.0 | 0.0 | 0.0 | 0.0 |
| 24 | 0.0 | 0.0 | 0.0 | 0.0 | 0.0 | 0.0 |
| 25 | 0.0 | 0.0 | 0.0 | 0.0 | 0.0 | 0.0 |
| 26 | 0.1 | 0.1 | 0.1 | 0.1 | 0.1 | 0.1 |
| 27 | 0.1 | 0.1 | 0.1 | 0.1 | 0.1 | 0.1 |
| 28 | 0.2 | 0.2 | 0.2 | 0.2 | 0.2 | 0.3 |
| 29* | 0.4 | 0.4 | 0.4 | 0.4 | 0.5 | 0.6 |
| 30** | 0.7 | 0.7 | 0.8 | 0.8 | 1.0 | 1.1 |
| 31** | 1.1 | 1.2 | 1.3 | 1.4 | 1.6 | |
| 32** | 1.7 | 1.9 | 2.0 | 2.2 | | |

*when using the opening angle limiter at 120°
 **when using the opening angle limiter at 105°

Protrusions / installed depth

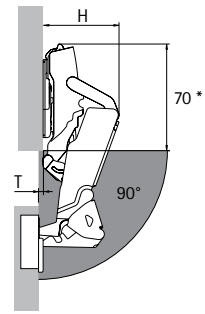

No door protrusion T up to distance D = 3, unobstructed interior for pull-outs.
 *Hinge closed: 80 mm

| Door mounting option | H mm (max. at 30°) | T mm (90°, D0) |
|----------------------|--------------------|----------------|
| Full overlay | 66 | -3 |
| Half overlay | 75.5 | 6.5 |

Full overlay

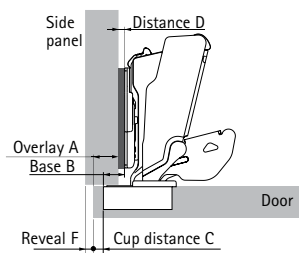

$$\text{Distance D} = C + B - A$$

= cup distance C + 12.5 mm - overlay A

| Overlay mm | Cup distance C mm | | | | | |
|---------------|-------------------|-----|-----|-----|-----|-----|
| | 3.0 | 4.0 | 4.5 | 5.0 | 6.0 | 7.0 |
| Distance D mm | | | | | | |
| 10 | 5.5 | 6.5 | 7.0 | 7.5 | 8.5 | 9.5 |
| 11 | 4.5 | 5.5 | 6.0 | 6.5 | 7.5 | 8.5 |
| 12 | 3.5 | 4.5 | 5.0 | 5.5 | 6.5 | 7.5 |
| 13 | 2.5 | 3.5 | 4.0 | 4.5 | 5.5 | 6.5 |
| 14 | 1.5 | 2.5 | 3.0 | 3.5 | 4.5 | 5.5 |
| 15 | 0.5 | 1.5 | 2.0 | 2.5 | 3.5 | 4.5 |
| 16 | | 0.5 | 1.0 | 1.5 | 2.5 | 3.5 |
| 17 | | | 0.0 | 0.5 | 1.5 | 2.5 |
| 18 | | | | | 0.5 | 1.5 |
| 19 | | | | | | 0.5 |

Half overlay

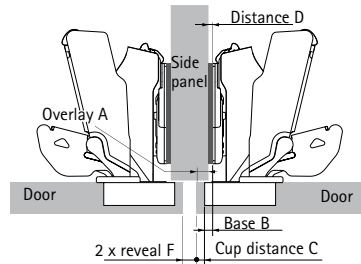

$$\text{Distance D} = C + B - A$$

= cup distance C + 3 mm - overlay A

| Overlay mm | Cup distance C mm | | | | | |
|---------------|-------------------|-----|-----|------|------|------|
| | 3.0 | 4.0 | 4.5 | 5.0 | 6.0 | 7.0 |
| Distance D mm | | | | | | |
| -2 | 8.0 | 9.0 | 9.5 | 10.0 | 11.0 | 12.0 |
| -1 | 7.0 | 8.0 | 8.5 | 9.0 | 10.0 | 11.0 |
| 0 | 6.0 | 7.0 | 7.5 | 8.0 | 9.0 | 10.0 |
| 1 | 5.0 | 6.0 | 6.5 | 7.0 | 8.0 | 9.0 |
| 2 | 4.0 | 5.0 | 5.5 | 6.0 | 7.0 | 8.0 |
| 3 | 3.0 | 4.0 | 4.5 | 5.0 | 6.0 | 7.0 |
| 4 | 2.0 | 3.0 | 3.5 | 4.0 | 5.0 | 6.0 |
| 5 | 1.0 | 2.0 | 2.5 | 3.0 | 4.0 | 5.0 |
| 6 | 0.0 | 1.0 | 1.5 | 2.0 | 3.0 | 4.0 |
| 7 | | 0.0 | 0.5 | 1.0 | 2.0 | 3.0 |
| 8 | | | | 0.0 | 1.0 | 2.0 |
| 9 | | | | | 0.0 | 1.0 |
| 10 | | | | | | 0.0 |

Advice

- ▶ For mounting plates and accessories, see page 90 - 97
- ▶ For fitting information and quality criteria, see page 88 - 89

Fast assembly concealed hinge

- ▶ **Intermat 9936 W45**
- ▶ **For 45° face angle, 95° opening angle**



- ▶ Concealed hinge with clip on installation
- ▶ Quality classification under EN 15570, Level 2
- ▶ For 45° face angle
- ▶ For door thickness 14 - 32 mm
- ▶ Cup diameter 35 mm
- ▶ Cup depth 10.5 mm
- ▶ Integrated overlay adjustment + 2 mm / - 2 mm
- ▶ Integrated depth adjustment + 2 mm / - 2 mm
- ▶ Height adjustment at mounting plate
- ▶ Hinge arm material: zinc die-cast nickel plated
- ▶ Hinge cup material: nickel plated steel

Intermat 9936 W45, opening angle 95°

| Cup assembly | Drilling pattern | Mounting hole ϕ x T mm | Overlay | | PU |
|---|------------------|-----------------------------|------------------|------------------|--------|
| | | | | | |
| | | | Base B 0 mm | Base B 6 mm | |
| For screwing on TH 42 | | - | 0 048 096 | 0 077 699 | 50 ea. |
| For pressing in TH 43 | | ϕ 10 x 11 | 0 048 097 | 0 077 700 | 50 ea. |
| With premounted expanding sockets TH 48 | | ϕ 10 x 11 | 9 043 668 | 9 043 669 | 50 ea. |

- ▶ **Intermat 9936**
- ▶ **For 45° face angle, 95° opening angle**

Minimum reveal per door

| Door thickness mm | Cup distance C mm | | | | | | | |
|-------------------|-------------------|-----|-----|-----|-----|-----|-----|--|
| | 3.0 | 4.0 | 4.5 | 5.0 | 6.0 | 7.0 | 8.0 | |
| 14 | 0.2 | 0.2 | 0.2 | 0.2 | 0.2 | 0.2 | 0.2 | |
| 15 | 0.3 | 0.2 | 0.2 | 0.2 | 0.2 | 0.2 | 0.2 | |
| 16 | 0.4 | 0.4 | 0.4 | 0.4 | 0.4 | 0.4 | 0.4 | |
| 17 | 0.5 | 0.5 | 0.5 | 0.5 | 0.5 | 0.5 | 0.5 | |
| 18 | 0.7 | 0.7 | 0.7 | 0.7 | 0.6 | 0.6 | 0.6 | |
| 19 | 0.9 | 0.9 | 0.9 | 0.8 | 0.8 | 0.8 | 0.8 | |
| 20 | 1.1 | 1.1 | 1.1 | 1.1 | 1.0 | 1.0 | 1.0 | |
| 21 | 1.4 | 1.3 | 1.3 | 1.3 | 1.3 | 1.2 | 1.2 | |
| 22 | 1.7 | 1.6 | 1.6 | 1.6 | 1.5 | 1.5 | 1.5 | |
| 23 | 2.0 | 1.9 | 1.9 | 1.9 | 1.8 | 1.8 | 1.7 | |
| 24 | 2.3 | 2.3 | 2.2 | 2.2 | 2.1 | 2.1 | 2.0 | |
| 25 | 2.8 | 2.7 | 2.6 | 2.6 | 2.5 | 2.4 | 2.4 | |
| 26 | 3.3 | 3.1 | 3.1 | 3.0 | 2.9 | 2.8 | 2.7 | |
| 27 | 4.2 | 3.7 | 3.6 | 3.5 | 3.3 | 3.2 | 3.1 | |
| 28 | 5.0 | 4.5 | 4.3 | 4.1 | 3.9 | 3.7 | 3.6 | |
| 29 | 5.9 | 5.4 | 5.2 | 4.9 | 4.6 | 4.3 | 4.1 | |
| 30 | 6.8 | 6.3 | 6.0 | 5.8 | 5.3 | 5.0 | 4.7 | |
| 31 | 7.8 | 7.2 | 6.9 | 6.6 | 6.1 | 5.7 | 5.4 | |
| 32 | 8.7 | 8.1 | 7.8 | 7.5 | 7.0 | 6.5 | 6.1 | |

Please note:

The table entries refer to doors with an edge radius of 1 mm.

On doors with other radii, the minimum reveal changes as follows:

Radius 0 mm:
Value in table + 0.4 mm

Radius 3 mm:
Value in table - 0.8 mm

Note

The drawings below show the hinges including mounting plate distances on a scale of 1:1. The door reveal can be measured directly from the individual distance lines by drawing in the required cup distance C (3 - 8 mm).

To determine the position for securing the mounting plate, measure along the selected distance line from the carcass front edge to the corresponding marking line for the line of holes.

Door thickness and cup distance C determine the required minimum reveal shown in the table.

Overlay (B 0 mm) - Scale 1:1

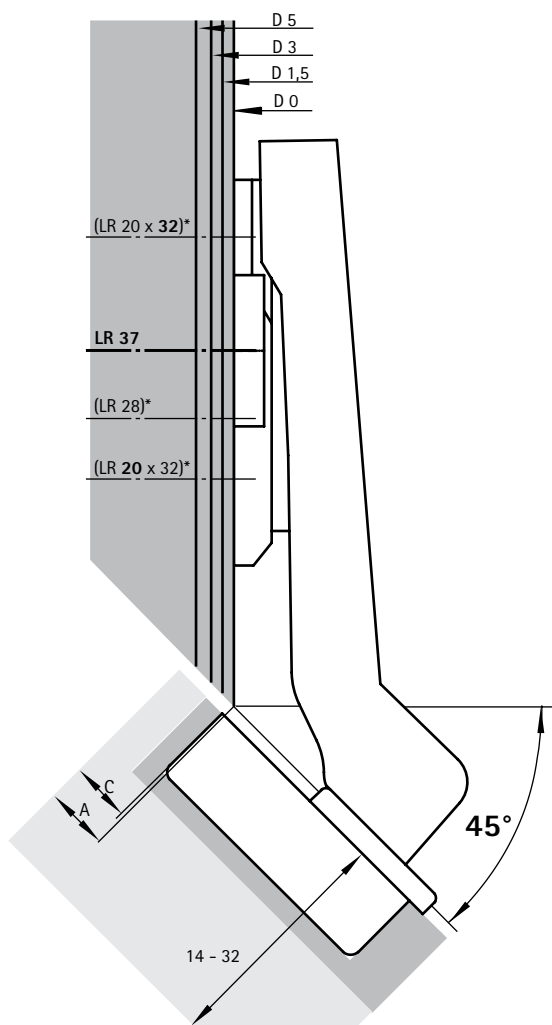

Overlay (B 6 mm) - Scale 1:1

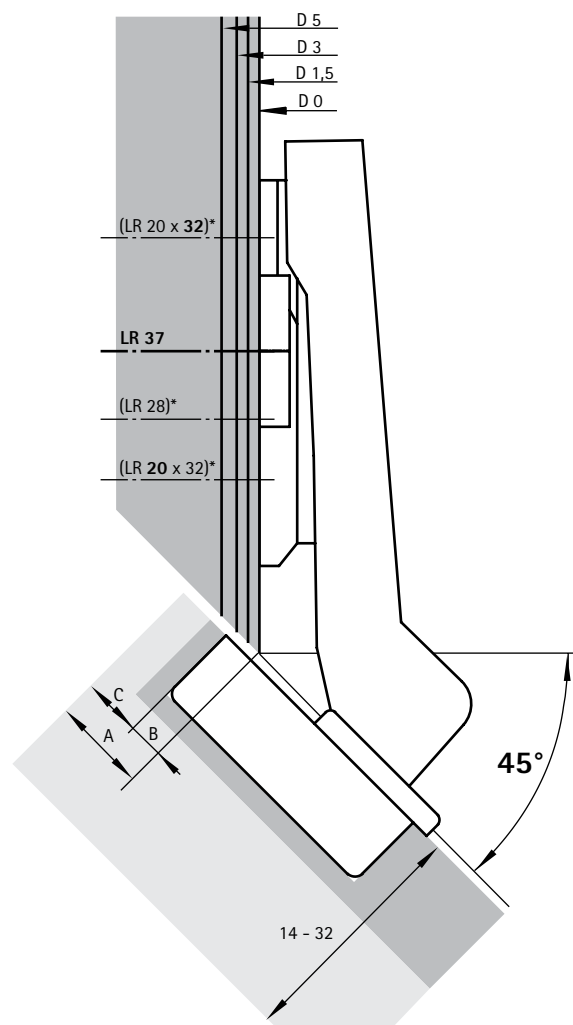

Advice

- ▶ For mounting plates and accessories, see page 90 - 97
- ▶ For fitting information and quality criteria, see page 88 - 89

Fast assembly concealed hinge

- ▶ **Intermat 9936 W90**
- ▶ **For 90° face angle, 95° opening angle**



- ▶ Concealed hinge with clip on installation
- ▶ Quality classification under EN 15570, Level 2
- ▶ For 90° face angle
- ▶ For door thickness 14 - 28 mm
- ▶ Cup diameter 35 mm
- ▶ Cup depth 10.5 mm
- ▶ Integrated adjustment of door offset + 2 mm / - 2 mm
- ▶ Integrated reveal adjustment + 2 mm / - 2 mm
- ▶ Height adjustment at mounting plate
- ▶ Hinge arm material: zinc die-cast nickel plated
- ▶ Hinge cup material: nickel plated steel

Intermat 9936 W90, opening angle 95°

Inset

Base B 5 mm

| Cup assembly | Drilling pattern | Mounting hole \varnothing x T mm | Base B 5 mm | PU |
|---|------------------|------------------------------------|------------------|---------|
| For screwing on TH 42 | | - | 0 077 708 | 50 ea. |
| For pressing in TH 43 | | $\varnothing 10 \times 11$ | 0 077 709 | 50 ea. |
| Flash fast installation TH 44 | | $\varnothing 10 \times 6$ | 1 061 347 | 200 ea. |
| With premounted expanding sockets TH 48 | | $\varnothing 10 \times 11$ | 9 043 672 | 50 ea. |

Fast assembly concealed hinge

► **Intermat 9936 W90**

► **For 90° face angle, 95° opening angle**

Minimum reveal per door

| Door thick- ness mm | Cup distance C mm | | | | | |
|------------------------|-------------------|-----|-----|-----|-----|-----|
| | 3.0 | 4.0 | 4.5 | 5.0 | 6.0 | 7.0 |
| 14 | 0.2 | 0.2 | 0.2 | 0.2 | 0.2 | 0.2 |
| 15 | 0.3 | 0.2 | 0.2 | 0.2 | 0.2 | 0.2 |
| 16 | 0.4 | 0.4 | 0.4 | 0.4 | 0.4 | 0.4 |
| 17 | 0.5 | 0.5 | 0.5 | 0.5 | 0.5 | 0.5 |
| 18 | 0.7 | 0.7 | 0.7 | 0.7 | 0.6 | 0.6 |
| 19 | 0.9 | 0.9 | 0.9 | 0.8 | 0.8 | 0.8 |
| 20 | 1.1 | 1.1 | 1.1 | 1.1 | 1.0 | 1.0 |
| 21 | 1.4 | 1.3 | 1.3 | 1.3 | 1.3 | |
| 22 | 1.7 | 1.6 | 1.6 | 1.6 | 1.5 | |
| 23 | 2.0 | 1.9 | 1.9 | 1.9 | 1.8 | |
| 24 | 2.3 | 2.3 | 2.2 | 2.2 | 2.1 | |
| 25 | 2.8 | 2.7 | 2.6 | 2.6 | | |
| 26 | 3.3 | 3.1 | 3.1 | | | |
| 27 | 4.2 | 3.7 | 3.6 | | | |
| 28 | 5.0 | | | | | |

Please note:

The table entries refer to doors with an edge radius of 1 mm.

On doors with other radii, the minimum reveal changes as follows:

Radius 0 mm:

Value in table + 0.4 mm

Radius 3 mm:

Value in table - 0.8 mm

Note

The drawings below show the hinges including mounting plate distances on a scale of 1:1.

Full overlay

- overlay A = cup distance C + 8.5 mm
- hole line distance X
- for LR37 mounting plate = 37 mm
- X > 20 mm

Inset

- hole line distance X
- for LR37 mounting plate = 28 mm - C - F
- X > 20 mm

Inset (B 5 mm) - Scale 1:1

Distance D = 5 mm - door offset

e.g. door offset 0 mm: distance D = 5 mm

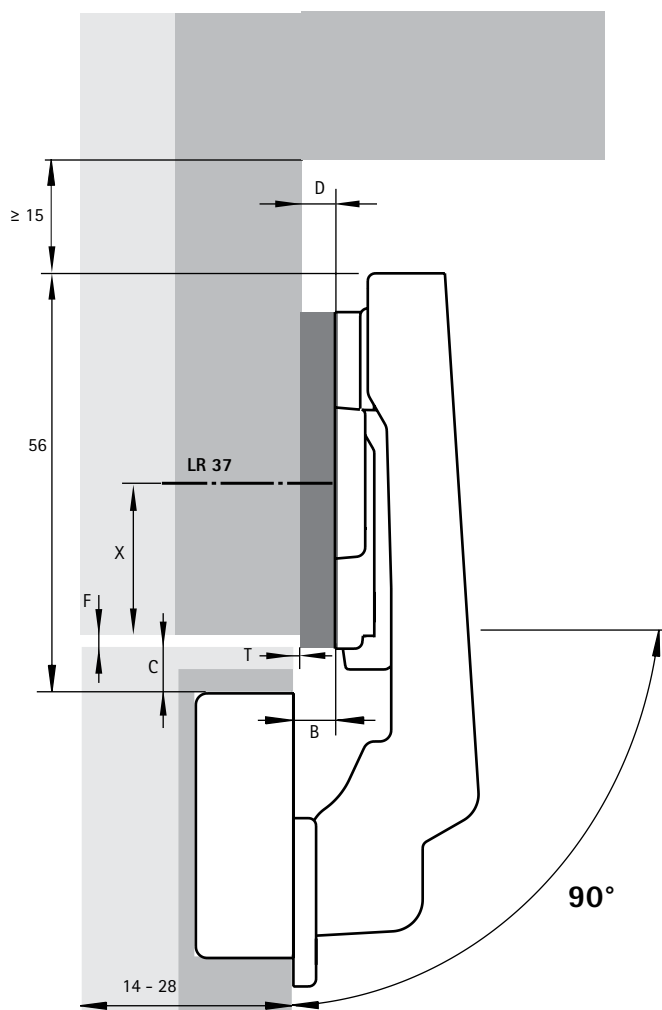

Advice

- For mounting plates and accessories, see page 90 - 97
- For fitting information and quality criteria, see page 88 - 89

Fast assembly concealed hinge

- ▶ Intermat 9904 for glass doors
- ▶ 95° opening angle



- ▶ Concealed hinge with clip on installation
- ▶ Quality classification under EN 15570, Level 2
- ▶ For glass thicknesses 4.0 - 6.5 mm
- ▶ Cup diameter 26 mm
- ▶ Integrated overlay adjustment + 2 mm / - 2 mm
- ▶ Integrated depth adjustment + 2.5 mm / - 1.5 mm
- ▶ Height adjustment at mounting plate
- ▶ Hinge arm material: zinc die-cast nickel plated
- ▶ Hinge cup material: black plastic

Intermat 9904, opening angle 95°

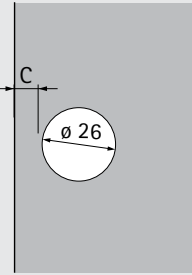
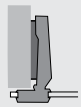
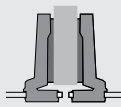
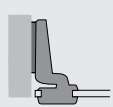
| Cup assembly | Drilling pattern | Mounting hole ϕ x T mm | Full overlay | Half overlay | Inset | PU |
|---------------------------|---|-----------------------------|--|--|--|--------|
| | | | Base B 11 mm | Base B 2,5 mm | Base B -4 mm | |
| For screwing on TU 12 / S |  | - |  0 072 960 |  0 072 967 |  0 072 968 | 50 ea. |

Decorative caps type A



| Finish | Order no. | PU |
|----------------------------|-----------|--------|
| 1 chrome-plated high-gloss | 0 040 341 | 50 set |
| 2 nickel-plated matt | 0 070 712 | 50 set |

Set, including cap mount and fixing screws. For glass thicknesses 5.5 - 6.5 mm a separate fixing screw 9 082 429 must be ordered.

Decorative caps type B



| Finish | Order no. | PU |
|----------------------------|-----------|--------|
| 1 chrome-plated high-gloss | 0 040 495 | 50 set |
| 2 nickel-plated matt | 0 070 713 | 50 set |

Set, including cap mount and fixing screws. For glass thicknesses 5.5 - 6.5 mm a separate fixing screw 9 082 429 must be ordered.

Fast assembly concealed hinge

- ▶ Intermat 9930 for corner cabinet folding doors
- ▶ 50° / 65° opening angle



- ▶ Concealed hinge with clip on installation
- ▶ Quality classification under EN 15570, Level 2
- ▶ Cup diameter 35 mm
- ▶ Cup depth 10.5 mm
- ▶ Diagonal adjustment + 9.5 mm / - 9.5 mm
- ▶ Integrated overlay adjustment, see sketch
- ▶ For integrated depth adjustment, see sketch
- ▶ Height adjustment at mounting plate
- ▶ Hinge arm material: zinc die-cast nickel plated
- ▶ Hinge cup material: nickel plated steel

Intermat 9930, opening angle 50° / 65°

Overlay

Base B 24 mm

PU

| Cup assembly | Drilling pattern | Mounting hole \varnothing x T mm | Base B 24 mm | PU |
|---|------------------|------------------------------------|------------------|--------|
| For screwing on TH 42 | | - | 0 045 036 | 50 ea. |
| For pressing in TH 43 | | \varnothing 10 x 11 | 0 045 037 | 50 ea. |
| With premounted expanding sockets TH 48 | | \varnothing 10 x 11 | 9 044 823 | 50 ea. |
| Flash fast installation TH 44 | | \varnothing 10 x 11 | 9 043 262 | 50 ea. |

Fast assembly concealed hinge

- ▶ **Intermat 9930 for corner cabinet folding doors**
- ▶ **50° / 65° opening angle**

Version A - Cup drill holes in one door

- ▶ All cup drillings in one door
- ▶ Hairline reveal can be provided between door units
- ▶ No cutaway in cup holes necessary
- ▶ Same door width for both elements
- ▶ Diagonal adjustment capability for easy adjustment to door thickness
- ▶ Same cup distance on both sides of side mounted door
- ▶ Hole line distance of 37 mm in the folding door panel
- ▶ For door thickness 16 - 21 mm
- ▶ Cup distance C 3 - 6 mm

Version A - Calculation of door width

Door width = carcase width - reveal F - door thickness

Version A - Calculation of mounting plate distance

For cup distance C = 4.5 mm: Distance D = 0 mm
 For cup distance C = 3.0 mm: Distance D = 1.5 mm

Differing cup distances can be evened out by depth and diagonal adjustment capability.

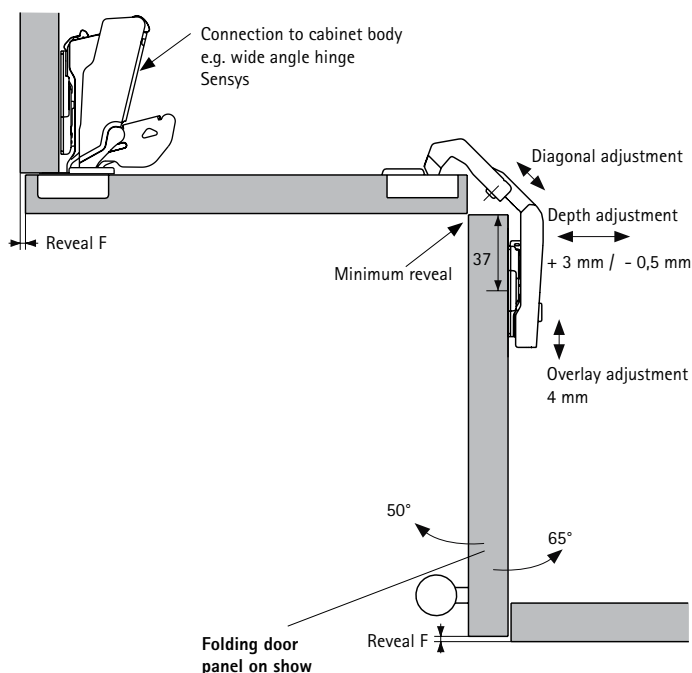

Advice

- ▶ For mounting plates and accessories, see page 90 - 97
- ▶ For fitting information and quality criteria, see page 88 - 89

Version B - Cup drill holes in both doors

- ▶ Both door units are the same
- ▶ No cutaway in cup holes necessary
- ▶ Diagonal adjustment capability for easy adjustment to door thickness
- ▶ Hole line distance of 41 mm in the side mounted door
- ▶ For door thickness 16 - 21 mm
- ▶ Cup distance C 3 - 6 mm

Version B - Calculation of door width

Door width = carcase width - reveal F - door thickness - 5 mm

Version B - Calculation of mounting plate distance

For cup distance C = 4.5 mm: Distance D = 0 mm
 For cup distance C = 3.0 mm: Distance D = 1.5 mm

Differing cup distances can be evened out by depth and diagonal adjustment capability.

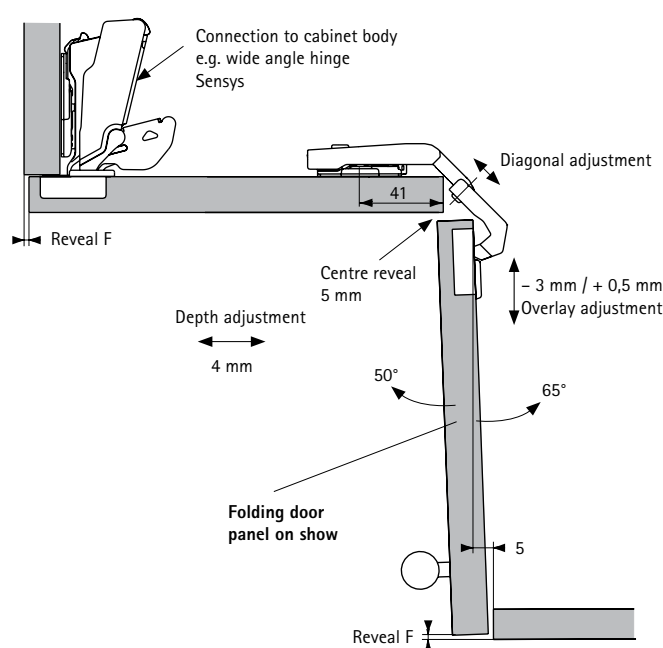

Fast assembly concealed hinge

- ▶ **Intermat**
- ▶ **Fitting information**

Full overlay door

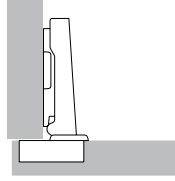

The door is in front of the carcass side and only a small gap remains at the side within which the door can open reliably. Alternatively, the door can also be overlaid fully. In this case sufficient space must be allowed at the side for the required minimum reveal. Straight hinges are used.

Half overlay door

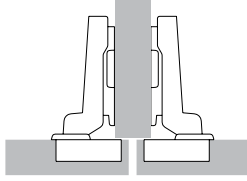

This is where two doors are positioned in front of a cabinet centre panel, with the required overall reveal between them (at least 2 x minimum reveal). In other words, each door has a smaller overlay and cranked hinges are therefore used.

Inset door

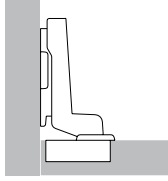

The door is positioned inside the carcass, i.e. next to the carcass side. Here too, a gap is needed so that the door can open reliably. Highly cranked hinges are used here. For an inset door, the mounting plate must be set back by the door thickness + 1 mm as well as by any any chosen door offset.

Minimum reveal

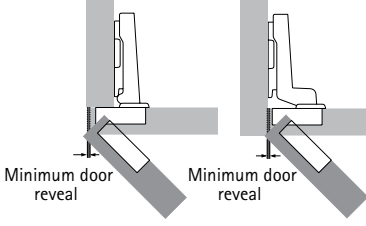

For full overlay and inset doors
The minimum reveal (also known as the door clearance or minimum clearance) is the space required at the side so that the door can open. The size of the minimum reveal depends on the cup distance C, the door thickness and the type of hinge selected. Radii on the door edges reduce the door clearance. The minimum reveal is shown in the table for the respective hinge types.

Minimum reveal

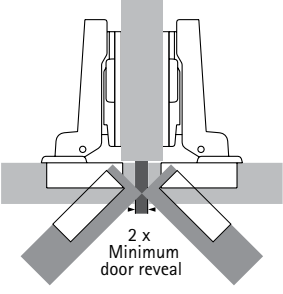

For half overlay doors
The total reveal selected between the doors must be at least twice the door clearance. Both doors can then be opened at the same time.

Cup distance C

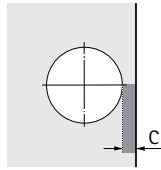

Cup distance C is the distance between the door edge and the edge of the cup drilling. The greater the distance selected for cup distance C, the smaller door clearance will be, i.e. the minimum reveal required.

Overlay / Base

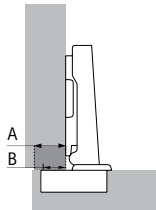

Overlay refers to the projection of the door in front of the carcass side. Base refers to the projection of the cup in front of the carcass side for a mounting plate distance of 0 mm.

A = Overlay
B = Base

Number of hinges per door

Door width, height and weight as well as the material quality of the door are decisive factors determining the number of hinges required.

The factors encountered in practice differ widely from case to case. For this reason, the number of hinges specified in the diagram must be understood as a guide only. If in doubt, it is recommended to carry out a trial mounting and adjust the number of hinges as necessary. For reasons of stability, space X between the hinges must always be made as large as possible. The space X must be at least 280 mm.

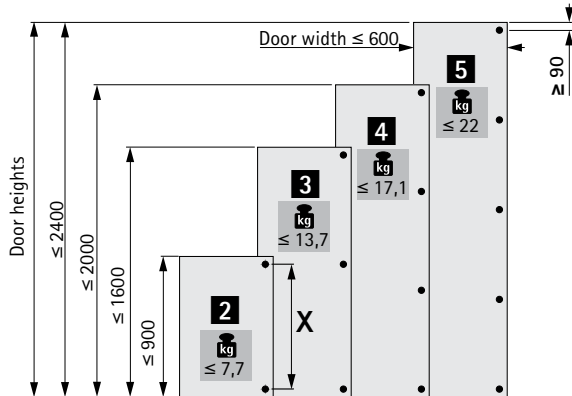

Fast assembly concealed hinge

- ▶ Intermat
- ▶ Fitting information

General calculation of distances

Mounting plates are available in various distances. The effective height of the mounting plate is defined by distance D. Distance D is embossed on the top of each mounting plate. A larger distance D reduces overlay for full and half overlay applications. On inset doors, a larger distance D increases the door reveal. Before determining the required distance,

check whether the desired reveal is equal to or greater than the required minimum reveal. If the desired reveal is less than the required minimum reveal, the required minimum reveal can be reduced by increasing cup distance C or by producing radii on the door edges.

Calculation of distances

For full overlay and half overlay doors

The required distance D can be determined after checking the minimum reveal. Ideally, the door reveal and cup distance should be selected to produce a distance D that is available as mounting plate.

Example: Working out distances according to the table

Overlay = 14 mm and cup distance C = 4.5 mm yield a distance D equal to 3.0 mm.

Example: Working out distances using the calculation formula

Hinge for full overlay door, base B = 12.5 mm
 Distance D = Cup distance C + base B - overlay A
 Distance D = 4.5 mm + 12.5 mm - 14 mm = 3.0 mm

Intermediate distances not available as mounting plate distances are achieved by adjusting the hinge overlay.

| Overlay mm | Cup distance C mm | | | | | |
|---------------|-------------------|-----|-----|-----|-----|-----|
| | 3,0 | 4,0 | 4,5 | 5,0 | 6,0 | 7,0 |
| | Distance D mm | | | | | |
| 10 | 5,5 | 6,5 | 7,0 | 7,5 | 8,5 | 9,5 |
| 11 | 4,5 | 5,5 | 6,0 | 6,5 | 7,5 | 8,5 |
| 12 | 3,5 | 4,5 | 5,0 | 5,5 | 6,5 | 7,5 |
| 13 | 2,5 | 3,5 | 4,0 | 4,5 | 5,5 | 6,5 |
| 14 | 1,5 | 2,5 | 3,0 | 3,5 | 4,5 | 5,5 |
| 15 | 0,5 | 1,5 | 2,0 | 2,5 | 3,5 | 4,5 |
| 16 | | 0,5 | 1,0 | 1,5 | 2,5 | 3,5 |
| 17 | | | 0,0 | 0,5 | 1,5 | 2,5 |
| 18 | | | | | 0,5 | 1,5 |
| 19 | | | | | | 0,5 |

Calculation of distances

For inset doors

When calculating the mounting plate distance using the table for the inset, allowance is automatically made for the reveal to be designated as the minimum reveal in relation to cup distance C and the door thickness in the minimum reveal table. If a reveal is to be produced that is larger than this minimum reveal, select a mounting plate distance of the appropriate size.

Example: Working out distances according to the table

According to the table, a door thickness = 20 mm and cup distance C = 4.5 mm produce a mounting plate distance of 1.5 mm. This gives the required minimum reveal, for example, of 1 mm. If a reveal of 2.5 mm is preferred instead, select a mounting plate distance which is 1.5 mm larger. In this example, therefore, a distance of 3 mm instead of 1.5 mm.

Example: Working out distances using the calculation formula

Hinge for inset application, base value B = - 4 mm
 Distance D = cup distance C + base B + reveal F
 Distance D = 4.5 mm - 4 mm + 1 mm = 1.5 mm

Intermediate distances not available as mounting plate distances are achieved by adjusting the overlay adjustment of the hinge.

| Door thickness mm | Cup distance C mm | | | | | |
|----------------------|-------------------|-----|-----|-----|-----|-----|
| | 3,0 | 4,0 | 4,5 | 5,0 | 6,0 | 7,0 |
| | Distance D mm | | | | | |
| 15 | | 0,2 | 0,7 | 1,2 | 2,2 | 3,2 |
| 16 | | 0,3 | 0,8 | 1,3 | 2,3 | 3,3 |
| 17 | | 0,4 | 0,9 | 1,4 | 2,4 | 3,4 |
| 18 | | 0,6 | 1,1 | 1,6 | 2,6 | 3,5 |
| 19 | | 0,8 | 1,3 | 1,8 | 2,7 | 3,7 |
| 20 | 0,1 | 1,0 | 1,5 | 2,0 | 3,0 | 3,9 |
| 21 | 0,4 | 1,3 | 1,8 | 2,3 | 3,2 | 4,2 |
| 22 | 1,2 | 1,8 | 2,2 | 2,6 | 3,6 | 4,5 |

Fast assembly concealed hinge

- ▶ System 8099 mounting plates - with oblong hole height adjustment
- ▶ For Sensys and Intermat

Cross mounting plate for screwing on

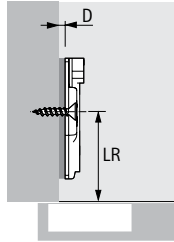

- ▶ For 4.5 mm \varnothing x 16 mm countersunk screws
- ▶ Quality classification under EN 15570, Level 3
- ▶ Hole spacing 32 mm
- ▶ Oblong hole height adjustment ± 3 mm
- ▶ Steel, nickel plated

| Hole line distance LR mm | Order no. / Distance D mm | | | | | PU |
|--------------------------|---------------------------|-----------|-----------|-----------|-----------|---------|
| | 0,0 | 1,5 | 3,0 | 5,0 | 8,0 | |
| 37 | 9 071 575 | 9 071 576 | 9 071 577 | 9 071 578 | | 200 ea. |
| | | | | | 9 075 009 | 50 ea. |

Cross mounting plate with expanding sockets and special screws

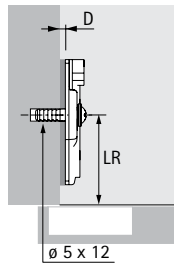

- ▶ For $\varnothing 5 \times 12$ mm holes
- ▶ Quality classification under EN 15570, Level 3
- ▶ Hole spacing 32 mm
- ▶ Oblong hole height adjustment ± 2 mm
- ▶ Steel, nickel plated

| Hole line distance LR mm | Order no. / Distance D mm | | | | PU |
|--------------------------|---------------------------|-----------|-----------|-----------|---------|
| | 0,0 | 1,5 | 3,0 | 5,0 | |
| 37 | 9 071 595 | 9 071 596 | 9 071 597 | 9 071 598 | 200 ea. |

Cross mounting plate with premounted Euro screws

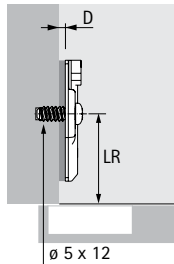

- ▶ For $\varnothing 5 \times 12$ mm holes
- ▶ Quality classification under EN 15570, Level 3
- ▶ Hole spacing 32 mm
- ▶ Oblong hole height adjustment ± 3 mm
- ▶ Steel, nickel plated

| Hole line distance LR mm | Order no. / Distance D mm | | | | | PU |
|--------------------------|---------------------------|-----------|-----------|-----------|-----------|---------|
| | 0,0 | 1,5 | 3,0 | 5,0 | 8,0 | |
| 37 | 9 071 625 | 9 071 626 | 9 071 627 | 9 071 628 | | 200 ea. |
| | | | | | 9 075 059 | 50 ea. |

Fast assembly concealed hinge

- ▶ System 8099 mounting plates with eccentric cam height adjustment
- ▶ For Sensys and Intermat

Cross mounting plate with expanding sockets and special screws

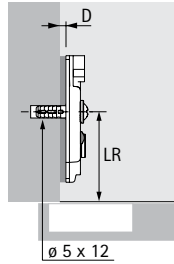

- ▶ For $\varnothing 5 \times 12$ mm holes
- ▶ Quality classification under EN 15570, Level 3
- ▶ Hole spacing 32 mm
- ▶ Eccentric cam height adjustment ± 2 mm
- ▶ Steel, nickel plated

| Hole line distance LR mm | Order no. / Distance D mm | | | | PU |
|--------------------------|---------------------------|-----------|-----------|-----------|---------|
| | 0,0 | 1,5 | 3,0 | 5,0 | |
| 37 | 9 071 655 | 9 071 656 | 9 071 657 | 9 071 658 | 200 ea. |

Patented "Hettich Direkt" cross mounting plate with locating pin and special screws

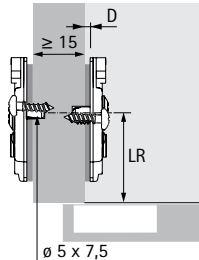

- ▶ For $\varnothing 5 \times 7.5$ mm holes
- ▶ Quality classification under EN 15570, Level 2
- ▶ Hole spacing 32 mm
- ▶ Half overlay door, from 15 mm side panel thickness
- ▶ Eccentric cam height adjustment ± 2 mm
- ▶ Steel, nickel plated

| Hole line distance LR mm | Order no. / Distance D mm | | | | PU |
|--------------------------|---------------------------|-----------|-----------|-----------|---------|
| | 0,0 | 1,5 | 3,0 | 5,0 | |
| 37 | 9 071 650 | 9 071 651 | 9 071 652 | 9 071 653 | 200 ea. |

Linear mounting plate for screwing on

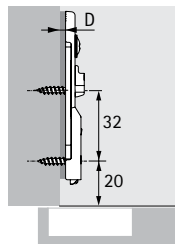

- ▶ For 3.5 mm $\varnothing \times 16$ mm countersunk screws
- ▶ Quality classification under EN 15570, Level 3
- ▶ Eccentric cam height adjustment ± 2 mm
- ▶ Steel, nickel plated

| Hole line distance LR mm | Order no. / Distance D mm | | PU |
|--------------------------|---------------------------|-----------|--------|
| | 1,5 | 3,0 | |
| 20 | 9 117 341 | 9 117 342 | 50 ea. |

Linear mounting plate for pressing in

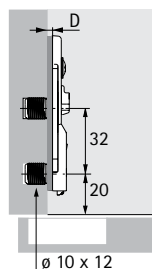

- ▶ For $\varnothing 10 \times 12$ mm drillings
- ▶ Quality classification under EN 15570, Level 3
- ▶ Eccentric cam height adjustment ± 2 mm
- ▶ Steel, nickel plated

| Hole line distance LR mm | Order no. / Distance D mm | | PU |
|--------------------------|---------------------------|-----------|--------|
| | 1,5 | 3,0 | |
| 20 | 9 117 344 | 9 117 388 | 50 ea. |

Fast assembly concealed hinge

- ▶ System 8099 mounting plates with oblong hole / eccentric cam height adjustment
- ▶ For Sensys in obsidian black

Cross mounting plate with premounted Euro screws

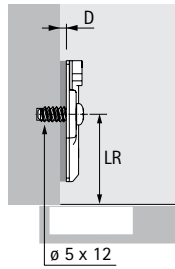

- ▶ For $\varnothing 5 \times 12$ mm holes
- ▶ Quality classification under EN 15570, Level 3
- ▶ Hole spacing 32 mm
- ▶ Oblong hole height adjustment ± 3 mm
- ▶ Steel in obsidian black

| Hole line distance LR mm | Order no. / Distance D mm | | | | PU |
|--------------------------|---------------------------|-----------|-----------|-----------|--------|
| | 0.0 | 1.5 | 3.0 | 5.0 | |
| 37 | 9 091 799 | 9 091 800 | 9 091 801 | 9 091 802 | 50 ea. |

Cross mounting plate with premounted Euro screws

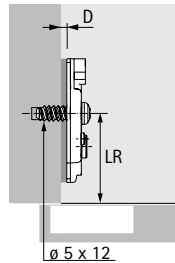

- ▶ For $\varnothing 5 \times 12$ mm holes
- ▶ Quality classification under EN 15570, Level 3
- ▶ Hole spacing 32 mm
- ▶ Eccentric cam height adjustment ± 2 mm
- ▶ Steel in obsidian black

| Hole line distance LR mm | Order no. / Distance D mm | | | | PU |
|--------------------------|---------------------------|-----------|-----------|-----------|--------|
| | 0.0 | 1.5 | 3.0 | 5.0 | |
| 37 | 9 091 803 | 9 091 804 | 9 091 805 | 9 091 806 | 50 ea. |

Linear mounting plate for screwing on

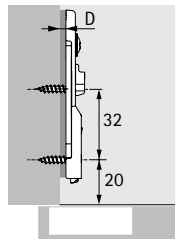

- ▶ For 3.5 mm $\varnothing \times 16$ mm countersunk screws
- ▶ Quality classification under EN 15570, Level 3
- ▶ Eccentric cam height adjustment ± 2 mm
- ▶ Steel in obsidian black

| Hole line distance LR mm | Order no. / Distance D mm | | PU |
|--------------------------|---------------------------|-----------|--------|
| | 1.5 | 3.0 | |
| 20 | 9 117 471 | 9 117 472 | 50 ea. |

- ▶ Accessories
- ▶ For Sensys

Angle adapter for cross mounting plates

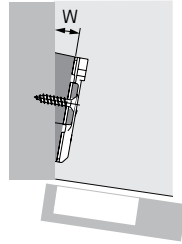

- ▶ For realizing face angle applications
- ▶ 5° angle adapter can be stacked on the other angle adapters
- ▶ A trial mounting is recommended
- ▶ Zinc die-cast nickel plated

| Hole line distance LR mm | Angle W° | Order no. | PU |
|--------------------------|----------|------------------|--------|
| 37 | 5 | 9 072 533 | 50 ea. |
| 37 | 10 | 9 072 534 | 50 ea. |
| 37 | 15 | 9 072 535 | 50 ea. |
| 37 | 20 | 9 072 536 | 50 ea. |

Can only be used with LR37 cross mounting plates for screwing on; Screw length is determined by specific configuration

Cover cap for Sensys hinge arm



- ▶ Can be used with Sensys hinges apart from 8657i / 8657 / 8687
- ▶ Cover caps with customised embossed or printed logo on request
- ▶ Steel, nickel plated

| Type | Order no. | PU |
|----------------------------|------------------|--------|
| Neutral | 9 088 249 | 50 ea. |
| Embossed with Hettich logo | 9 088 250 | 50 ea. |

Cover cap for Sensys zero protrusion hinge



- ▶ Can be used with Sensys hinges 8657i, 8657, 8687
- ▶ Cover caps with customised print available on request
- ▶ Plastic, anthracite

| Type | Order no. | PU |
|---------------------------|------------------|--------|
| Neutral | 9 099 870 | 50 ea. |
| Printed with Hettich logo | 9 099 871 | 50 ea. |

Cover cap for Sensys hinge cup



- ▶ Can be used for hinges with cup in Sensys design
- ▶ Can be used for all attachment options apart from Fix and premounted wood screw
- ▶ Steel, nickel plated

| Type | Dimension X mm | Order no. | PU |
|--------|----------------|------------------|--------|
| For TH | 68,2 | 9 088 251 | 50 ea. |

Fast assembly concealed hinge

- ▶ Accessories
- ▶ For Sensys

Adapter for reducing drilling depth

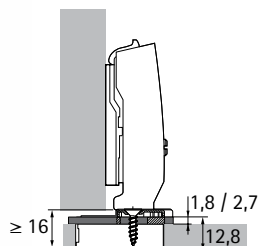

- ▶ To reduce the required depth of the cup drilling in thin or highly softened doors
- ▶ Can be used with hinge cup for screwing on
- ▶ The gap between carcass and door increases by the thickness of the adapter
- ▶ Attachment by $\varnothing 4 \times 16$ mm countersunk screws
- ▶ Plastic, transparent

| Type | Thickness mm | Order no. | PU |
|---------------|--------------|------------------|--------|
| for TH 52 cup | 1,8 | 9 073 595 | 50 ea. |

Opening angle limiter for Sensys 8645i



- ▶ For reducing the opening angle of doors with adjoining elements
- ▶ Avoids damage to the front panel
- ▶ Also suitable for hinges without Silent System, without self closing feature
- ▶ Plastic, white
- ▶ For installation notes, see Technical information

| Type | Order no. | PU |
|-----------------------------|------------------|--------|
| Limitation from 110° to 85° | 9 072 540 | 50 ea. |

Opening angle limiter for Sensys 8639i W



- ▶ For reducing the opening angle of doors with adjoining elements
- ▶ Avoids damage to the front panel
- ▶ Also suitable for hinges without Silent System, without self closing feature
- ▶ Plastic, black
- ▶ For installation notes, see Technical information

| Type | Order no. | PU |
|----------------------------|------------------|--------|
| Limitation from 95° to 85° | 9 072 541 | 50 ea. |

Opening angle limiter for Sensys thin door hinges



- ▶ Limitation from 110° to 85°
- ▶ For reducing the opening angle of doors with adjoining elements
- ▶ Avoids damage to the front panel
- ▶ Plastic, anthracite

| Type | Order no. | PU |
|-----------------------------|------------------|--------|
| Limitation from 110° to 85° | 9 076 440 | 50 ea. |

Opening angle limiter for Sensys 8657i



- ▶ For reducing the opening angle of doors with adjoining elements
- ▶ Avoids damage to the front panel
- ▶ Also suitable for hinges without Silent System, without self closing feature
- ▶ Plastic, anthracite
- ▶ For installation notes, see Technical information

| Type | Order no. | PU |
|--------------------------------------|------------------|--------|
| Limitation from 165° to 105° or 120° | 9 090 756 | 50 ea. |

Fast assembly concealed hinge

- ▶ Accessories
- ▶ For Sensys in obsidian black

Opening angle limiter for Sensys 8657i



- ▶ For reducing the opening angle of doors with adjoining elements
- ▶ Avoids damage to the front panel
- ▶ Also suitable for hinges without Silent System, without self closing feature
- ▶ Plastic, anthracite
- ▶ For installation notes, see Technical information

| Type | Order no. | PU |
|-------------------------------------|------------------|--------|
| Limitation from 165° to 90° or 135° | 9 090 864 | 50 ea. |

Opening angle limiter for Sensys 8631i



- ▶ For reducing the opening angle of doors with adjoining elements
- ▶ Avoids damage to the front panel
- ▶ Also suitable for hinges without Silent System, without self closing feature
- ▶ Steel
- ▶ For installation notes, see Technical information

| Type | Order no. | PU |
|----------------------------|------------------|--------|
| Limitation from 95° to 85° | 9 103 006 | 50 ea. |

Aid for installing opening angle limiter



- ▶ Can be used with the following opening angle limiters
 - Order no. 9 072 540 for Sensys 8645i / 8645 / 8675
 - Order no. 9 072 541 for Sensys 8639i W / 8639 W / 8669 W

| Order no. | PU |
|------------------|---------|
| 9 081 657 | 100 ea. |

Cover cap for Sensys hinge arm



- ▶ Can be used with Sensys hinges apart from 8657i
- ▶ Embossed with Hettich logo
- ▶ Cover caps with customised embossed or printed logo on request
- ▶ Steel in obsidian black

| Order no. | PU |
|------------------|--------|
| 9 091 821 | 50 ea. |

Cover cap for Sensys hinge cup



- ▶ Can be used for hinges with cup in Sensys design
- ▶ Steel in obsidian black

| Version | Order no. | PU |
|-------------|------------------|--------|
| for TH / TS | 9 091 822 | 50 ea. |

Fast assembly concealed hinge

- ▶ Accessories
- ▶ For Intermat

Cover cap for Intermat hinge arm



- ▶ Can be used with Intermat hinges
- ▶ Cover caps with customised embossed or printed logo on request
- ▶ Steel, nickel plated

| Type | Order no. | PU |
|----------------------------|-----------|--------|
| Neutral | 9 101 552 | 50 ea. |
| Embossed with Hettich logo | 9 102 082 | 50 ea. |

Opening angle limiter for Intermat 9943



- ▶ For reducing door opening angle to avoid collisions with adjoining elements
- ▶ Avoids damage to the front panel
- ▶ Also suitable for hinges without self closing feature
- ▶ Plastic, colourless
- ▶ For installation notes, see Technical information

| Order no. | PU |
|-----------|--------|
| 9 088 253 | 50 ea. |

Screw and sleeve



- ▶ Press in sleeve and screw
- ▶ Used for example, to replace hinges with cup assembly for pressing in
- ▶ \varnothing 10 x 11 mm
- ▶ Colourless plastic / steel, nickel plated

| Order no. | PU |
|-----------|---------|
| 0 045 169 | 200 set |

Fixing screw for aluminium framed door hinge



- ▶ Countersunk head
- ▶ Pozidrive screw
- ▶ \varnothing 3.5 x 16 mm
- ▶ Steel, nickel plated

| Order no. | PU |
|-----------|---------|
| 0 041 296 | 200 ea. |

Fixing screw for glass door hinges



- ▶ For glass 5.5 - 6.5 mm thick
- ▶ Steel, nickel plated

| Order no. | PU |
|-----------|---------|
| 9 082 429 | 200 ea. |

Cover cap \varnothing 35 mm

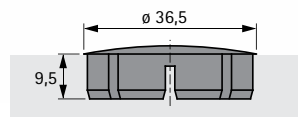

- ▶ For drilling \varnothing 35 mm x 9.5 mm
- ▶ Plastic

| Colour | Order no. | PU |
|--------|-----------|---------|
| white | 0 025 204 | 100 ea. |

Fast assembly concealed hinge

- ▶ Accessories
- ▶ For Intermat

Door damper for pressing in

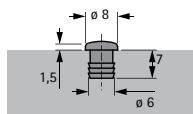

- ▶ For drilling \varnothing 6 mm x 7 mm
- ▶ Plastic

| Colour | Order no. | PU |
|--------|-----------|----------|
| white | 0 025 048 | 1000 ea. |

Door damper for sticking on

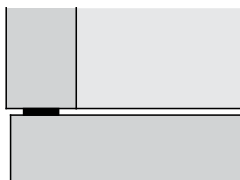

- ▶ \varnothing 8 mm, Self adhesive
- ▶ 50 buffers per sheet
- ▶ Plastic, transparent

| Order no. | PU |
|-----------|-----------|
| 0 046 695 | 1,000 ea. |

Door damper for pressing in

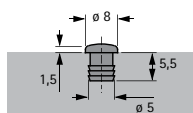

- ▶ For drilling \varnothing 5 mm x 5.5 mm
- ▶ Plastic, transparent

| Order no. | PU |
|-----------|----------|
| 9 079 298 | 1000 ea. |

Fixing screw for hinge cup for screwing on



- ▶ Countersunk head
- ▶ Pozidrive screw
- ▶ \varnothing 3.5 x 16 mm
- ▶ Steel, nickel plated

| Order no. | PU |
|-----------|----------|
| 1 004 895 | 1000 ea. |

Shallow countersunk head



- ▶ Shallow countersunk head
- ▶ Pozidrive screw
- ▶ Steel, galvanised

| Dimensions mm | Order no. | PU |
|------------------------|-----------|---------|
| \varnothing 6.3 x 11 | 0 047 451 | 200 ea. |

Deep countersunk head



- ▶ Deep countersunk head
- ▶ Pozidrive screw
- ▶ Steel, galvanised

| Dimensions mm | Order no. | PU |
|------------------------|-----------|---------|
| \varnothing 6.3 x 14 | 0 047 452 | 200 ea. |

Deep countersunk head



- ▶ Self tapping countersunk screw
- ▶ For use with hinges and mounting plates for screwing on in combination with hard materials, such as solid surface material or full core panel
- ▶ Not suitable for use in engineered wood
- ▶ Steel, nickel plated

| Design | Order no. | PU |
|--|-----------|---------|
| for drilling \varnothing 3.6 mm x 8 mm | 9 217 435 | 100 ea. |
| for drilling \varnothing 5 mm x 8 mm | 9 238 321 | 100 ea. |

Optional Silent System

► For concealed hinges



A measurable benefit for every furniture user
Closing furniture doors produce irritating noise in the home environment. Intermat with Silent System controls the movement of furniture doors, leaving them to close quietly and gently. Peace and quiet are immediately restored, enhancing living comfort in any home situation.



Greater customer benefits
Silent System action can be optimised to suit the size and weight of the doors at a setting wheel.



Elegance for the hinge cup
This particularly attractive Silent System can be used for standard door mounting styles.



Convenient, for clipping on
Silent System simply clips onto the hinge arm, thus enabling tool-less assembly.



Screwed on in seconds flat
This option is mainly used in conjunction with hinges for unusual face angles.

Optional Silent System

- ▶ Intermat fast assembly concealed hinge
- ▶ For Intermat

Silent System damper for hinge cup



- ▶ for screwing onto the hinge cup
- ▶ Cushioning effect infinitely adjustable at setting wheel
- ▶ Use two Silent System elements for doors weighing over 13.5 kg
- ▶ Upgradeable
- ▶ Zinc die-cast nickel plated

| For hinge | Cup version | Door mounting option | Order no. | PU |
|---------------|---------------------|----------------------|-----------|--------|
| Intermat 9943 | TH 42, TH 43, TH 48 | full overlay | 0 060 581 | 50 ea. |

Installation

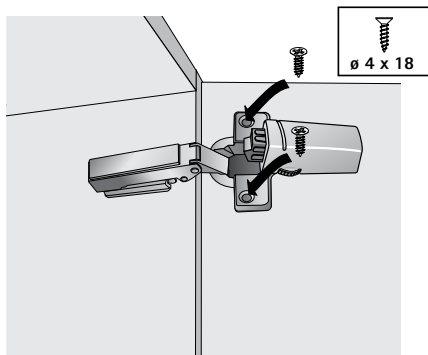

Optional Silent System

- ▶ Intermat fast assembly concealed hinge
- ▶ For Intermat

Clip on Silent System



- ▶ For clipping onto the hinge arm
- ▶ Cushioning effect infinitely adjustable at setting wheel
- ▶ Tool-less assembly / removal
- ▶ Use two Silent System elements for doors weighing over 13.5 kg
- ▶ Easy upgradeable
- ▶ Zinc die-cast nickel plated

| For hinge | Door mounting option | Verwendung mit | Order no. | PU |
|----------------------|----------------------|------------------------------|-----------|--------|
| Intermat 9943 / 9936 | full overlay | all mounting plate distances | 0 060 576 | 50 ea. |

Installation

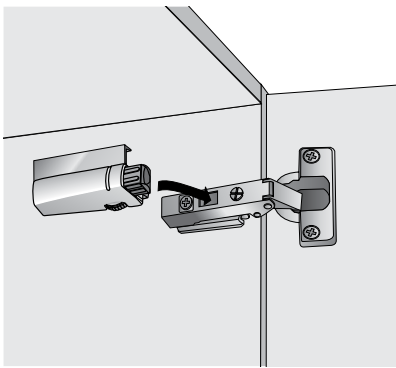

Removal

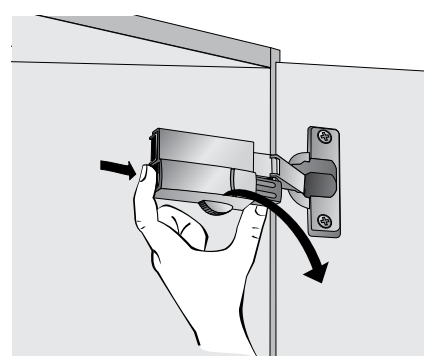

Optional Silent System

- ▶ Intermat fast assembly concealed hinge
- ▶ For Intermat

Screw on Silent System



- ▶ for screwing onto top or bottom carcase panel
- ▶ Cushioning effect infinitely adjustable via setting screw
- ▶ Installation on hinge side
- ▶ Use two Silent System elements for doors weighing over 13.5 kg
- ▶ Upgradeable
- ▶ Zinc die-cast nickel plated

| | | |
|----------------------------|-----------|--------|
| Door mounting option | Order no. | PU |
| Full overlay, half overlay | 0 060 579 | 50 ea. |

Assembly drawing

Intermat 9943
Intermat 9936
Intermat 9944

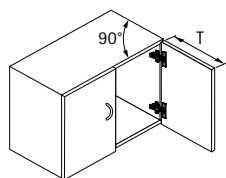

| T | X |
|-------|----|
| < 300 | 1 |
| < 450 | 9 |
| < 600 | 15 |

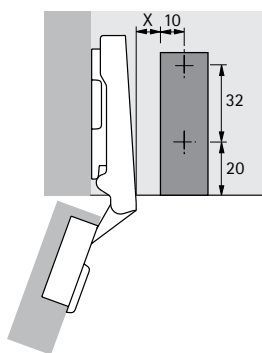

Installation

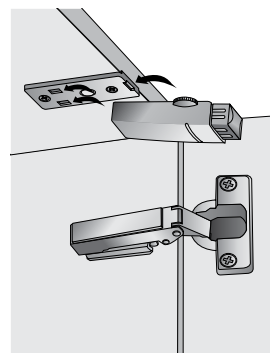
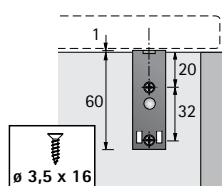
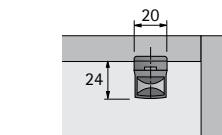

Assembly drawing

Intermat 9936 W20
Intermat 9936 W30
Intermat 9936 W45

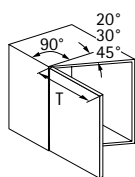

| T | X |
|-------|----|
| < 300 | 1 |
| < 450 | 9 |
| < 600 | 15 |

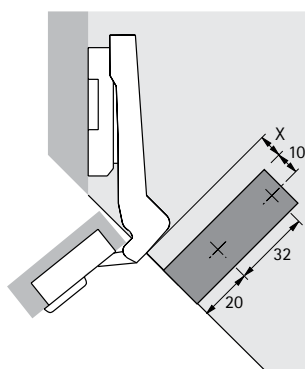

Assembly drawing

Intermat 9936 W90

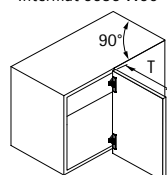

| T | X |
|-------|----|
| < 300 | 1 |
| < 450 | 9 |
| < 600 | 15 |

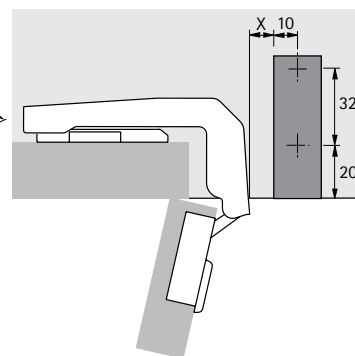

Push to open opening system for handleless furniture fronts

► Push to open for hinges



Simple, handleless, good: Push to open for hinges

A gentle press on the door is all it takes for the Push to open piston to move the door into a position that easily lets you get your fingers behind to open it. Depending on use, the door remains in piston end position or swings open widely. The door is closed by pressing on it again.



Take advantage of market potentials:
Simply make furniture stand apart with handleless design - with Push to open from Hettich



Costs under control:
You can also use Push to open with standard hinges and Push to open Pin while leaving production processes unchanged



Maximum customer satisfaction:
Reliable operation, unauthorised unlocking ruled out. Any installation tolerances can be corrected by the large adjustment range.



Future proof and versatile:
Meet tomorrow's demands the easy way. Whichever way furniture trends go, our comprehensive product range has the answer.

► Summary



Push to open for hinges

- Range summary / technical comparison

104 - 107



Push to open Pin

- For screwing on
- For drilling in

108

109



Push to open Pin Strong

- For screwing on
- For drilling in

110

111



Push to open Magnet

- For screwing on
- For drilling in

112

113



Accessories

- Design adapter for Push to open, drill in versions
- Counterplates for Push to open Magnet

114

115





Assembly aids

- For Push to open, drill in versions

116





Push to open opening system for handleless furniture fronts

- ▶ Push to open for hinges
- ▶ Range summary / technical comparison

| | Push to open Pin  | Push to open Pin  | Push to open Pin Strong  |
|----------------------|---|---|--|
| Page | 109 | 110 | 111 |
| Application | <ul style="list-style-type: none"> ▶ Concealed hinges | <ul style="list-style-type: none"> ▶ Concealed hinges | <ul style="list-style-type: none"> ▶ Concealed hinges ▶ For use in combination with particularly tall and / or heavy doors |
| Door mounting option | <ul style="list-style-type: none"> ▶ Full overlay ▶ Half overlay ▶ Inset | <ul style="list-style-type: none"> ▶ Full overlay | <ul style="list-style-type: none"> ▶ Full overlay ▶ Half overlay ▶ Inset |
| Installation | <ul style="list-style-type: none"> ▶ For screwing on | <ul style="list-style-type: none"> ▶ For drilling in | <ul style="list-style-type: none"> ▶ For screwing on |
| Material / colour | Plastic <ul style="list-style-type: none"> ▶ anthracite ▶ light grey ▶ white | Plastic <ul style="list-style-type: none"> ▶ anthracite ▶ light grey ▶ white | Plastic <ul style="list-style-type: none"> ▶ anthracite ▶ light grey ▶ white |

Push to open opening system for handleless furniture fronts

- ▶ Push to open for hinges
- ▶ Range summary / technical comparison

| Push to open Pin Strong  | Push to open Magnet  | Push to open Magnet  | Designer adapter  |
|--|---|---|--|
| 112 | 113 | 114 | 115 |
| <ul style="list-style-type: none"> ▶ Concealed hinges ▶ For use in combination with particularly tall and / or heavy doors | <ul style="list-style-type: none"> ▶ Hinges without self closing feature | <ul style="list-style-type: none"> ▶ Hinges without self closing feature | <ul style="list-style-type: none"> ▶ Concealed hinges ▶ Hinges without self closing feature |
| <ul style="list-style-type: none"> ▶ Full overlay | <ul style="list-style-type: none"> ▶ Full overlay ▶ Half overlay ▶ Inset | <ul style="list-style-type: none"> ▶ Full overlay | <ul style="list-style-type: none"> ▶ Full overlay ▶ Half overlay ▶ Inset (long stroke length) |
| <ul style="list-style-type: none"> ▶ For drilling in | <ul style="list-style-type: none"> ▶ For screwing on | <ul style="list-style-type: none"> ▶ For drilling in | <ul style="list-style-type: none"> ▶ For screwing on |
| Plastic <ul style="list-style-type: none"> ▶ anthracite ▶ light grey ▶ white | Plastic <ul style="list-style-type: none"> ▶ white | Plastic <ul style="list-style-type: none"> ▶ white | <ul style="list-style-type: none"> ▶ Zinc die-cast nickel plated |

Push to open opening system for handleless furniture fronts

- ▶ Push to open for hinges
- ▶ Application areas / recommended applications

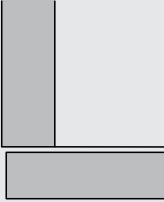
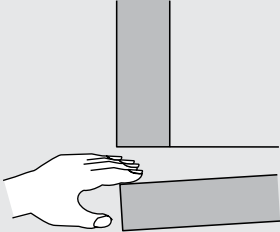
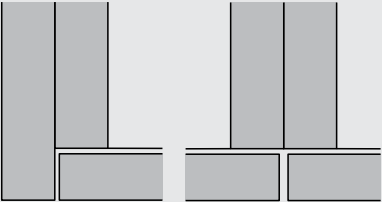
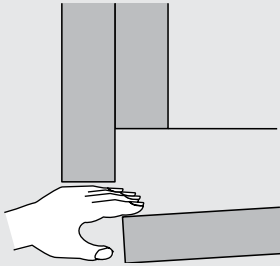
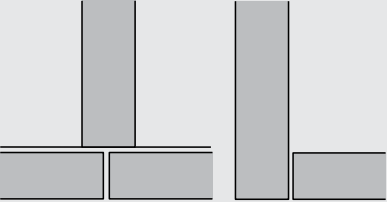
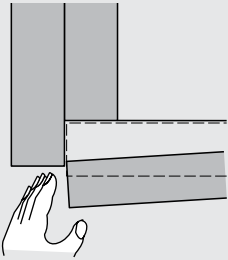
| 1 Design | 2 Door use | 3 Hinge function |
|---|--|--|
| <p>The door is freely accessible from the side. Full overlay (non adjacent components)</p>  | <p>Reaching behind the door</p>  | <p>with self closing feature</p> <hr/> <p>without self closing feature</p> |
| <p>The door is not freely accessible from the side because it is adjacent to another component.</p> <p>Full overlay (e.g. adjacent panel, another cabinet)</p>  | <p>Reaching in behind the door</p>  | <p>with self closing feature</p> <hr/> <p>without self closing feature</p> |
| <p>Half overlay Inset</p>  | <p>Reaching in at side of door</p>  | <p>with self closing feature</p> <hr/> <p>without self closing feature</p> |

Push to open opening system for handleless furniture fronts

- ▶ Push to open for hinges
- ▶ Application areas / recommended applications

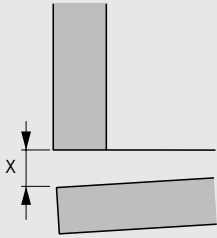
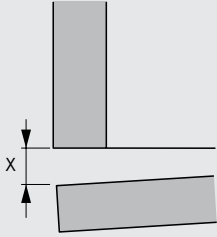
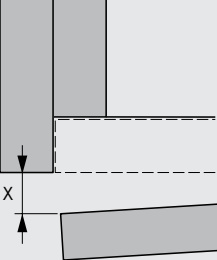
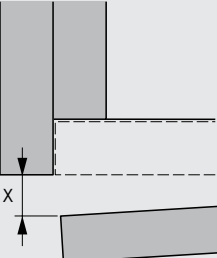
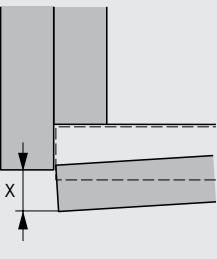
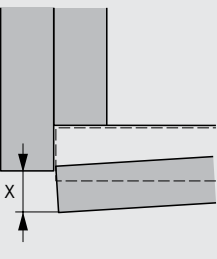
| 4 Finger pull space / finger pull area X | | 5 Recommended products |
|---|--|---|
|  | <p>X = approx. 14 mm</p> | <p>Push to open Pin, short version</p> |
| | <p>X = approx. 37 mm</p> | <p>Push to open Pin, long version</p> |
|  | <p>X = 14 mm min. The hinges used make the door open further.</p> | <p>Push to open Magnet, short version</p> |
| | <p>X = 37 mm min. The hinges used make the door open further.</p> | <p>Push to open Magnet, long version</p> |
|  | <p>If the adjacent component projects in front of the door the finger pull space / finger pull area is reduced accordingly. Finger pull space X is defined by the stroke length of 37 mm less door thickness.</p> | <p>Push to open Pin, long version</p> |
|  | <p>If the adjacent component projects in front of the door the finger pull space / finger pull area is reduced accordingly. Finger pull space X is defined by the stroke length of 37 mm less door thickness. The hinges used make the door open further.</p> | <p>Push to open Magnet, long version</p> |
|  | <p>X = approx. 14 mm If the adjacent component projects in front of the door the finger pull space / finger pull area X is reduced accordingly.</p> | <p>Push to open Pin, short version</p> |
|  | <p>X = 14 mm min. If the adjacent component projects in front of the door the finger pull space / finger pull area X is reduced accordingly. The hinges used make the door open further.</p> | <p>Push to open Magnet, short version</p> |

Push to open opening system for handleless furniture fronts

- ▶ Push to open Pin for screwing on
- ▶ For hinges with self closing feature



- ▶ For use with concealed hinges
- ▶ Suitable for full overlay, half overlay and inset doors
- ▶ Large adjustment range of 6 mm
- ▶ Activating gap 1.4 mm
- ▶ For using short / long versions, see „Application areas / recommended applications“, pages 122 - 123
- ▶ For installation, see installation notes, pages 135 - 137
- ▶ Plastic

Push to open Pin



- Set comprises:
- ▶ 1 Push to open Pin
 - ▶ 1 adapter top part
 - ▶ 1 adapter base part

| Article | Order no. / colour | | | PU |
|--------------|--------------------|------------|-----------|--------|
| | anthracite | light grey | white | |
| Long version | 9 089 626 | 9 089 601 | 9 089 587 | 25 set |

Drilling pattern for long version, overlay door or inset door

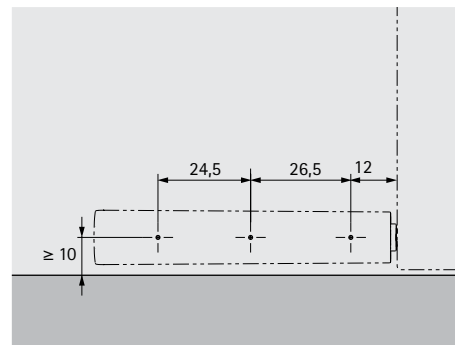
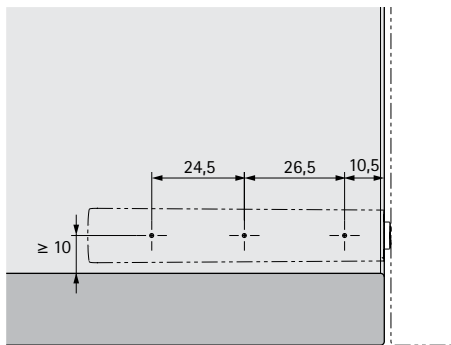

Push to open opening system for handleless furniture fronts

- ▶ Push to open Pin for drilling in
- ▶ For hinges with self closing feature



- ▶ For use with concealed hinges
- ▶ For full overlay doors
- ▶ Large adjustment range of 6 mm
- ▶ Activating gap 1.4 mm
- ▶ For using short / long versions, see „Application areas / recommended applications“, pages 122 - 123
- ▶ For installation, see installation notes, pages 135 - 137
- ▶ Plastic

Push to open Pin



| Article | Order no. / colour | | | PU |
|---------------|--------------------|------------------|------------------|--------|
| | anthracite | light grey | white | |
| Short version | | | 9 089 588 | 25 ea. |
| Long version | 9 089 628 | 9 089 603 | 9 089 589 | 25 ea. |

Drilling pattern for short version, overlay door

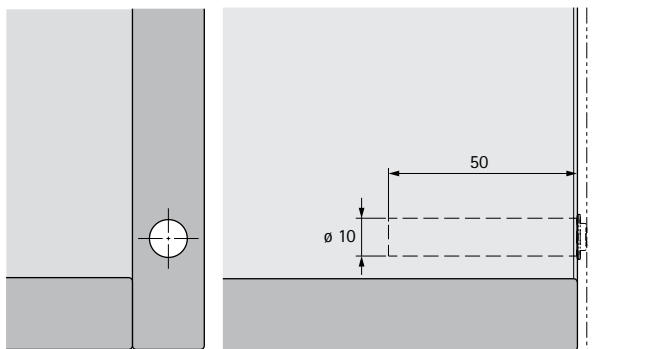

Drilling pattern for long version, overlay door

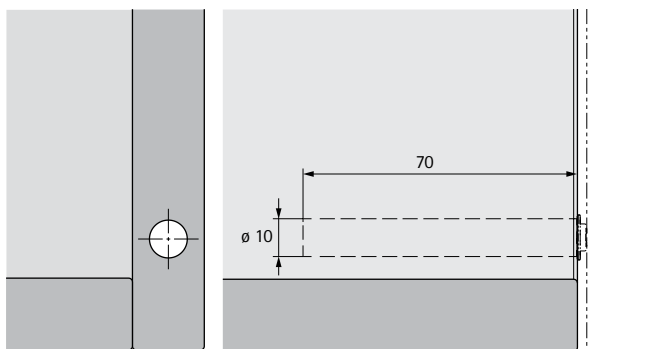

Push to open opening system for handleless furniture fronts

- ▶ Push to open Pin Strong for screwing on
- ▶ For hinges with self closing feature



- ▶ For use with concealed hinges
- ▶ For use in combination with particularly tall and / or heavy doors for example
- ▶ Suitable for full overlay, half overlay and inset doors
- ▶ Large adjustment range of 6 mm
- ▶ Activating gap 1.4 mm
- ▶ For using short / long versions, see „Application areas / recommended applications“, pages 122 - 123
- ▶ For installation, see installation notes, pages 135 - 137
- ▶ Plastic

Push to open Pin Strong



- Set comprises:
- ▶ 1 Push to open Pin Strong
 - ▶ 1 adapter top part
 - ▶ 1 adapter base part

| Article | Order no. / colour | | | PU |
|--------------|--------------------|------------|-----------|--------|
| | anthracite | light grey | white | |
| Long version | 9 089 636 | 9 089 611 | 9 089 597 | 25 set |

Drilling pattern for long version, overlay door or inset door

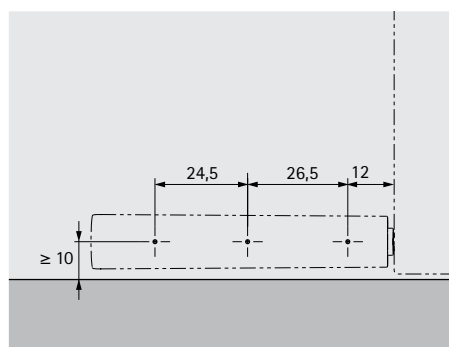
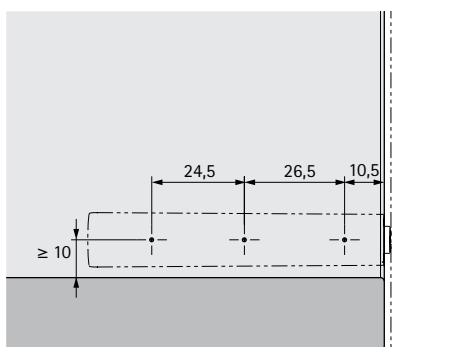

Push to open opening system for handleless furniture fronts

- ▶ Push to open Pin Strong for drilling in
- ▶ For hinges with self closing feature



- ▶ For use with concealed hinges
- ▶ For use in combination with particularly tall and / or heavy doors for example
- ▶ Cartridge can be identified by the red end cap
- ▶ For full overlay doors
- ▶ Large adjustment range of 6 mm
- ▶ Activating gap 1.4 mm
- ▶ For using short / long versions, see „Application areas / recommended applications“, pages 122 - 123
- ▶ For installation, see installation notes, pages 135 - 137
- ▶ Plastic

Push to open Pin Strong



| Article | Order no. / colour | | | PU |
|--------------|--------------------|------------|-----------|--------|
| | anthracite | light grey | white | |
| Long version | 9 089 638 | 9 089 613 | 9 089 599 | 25 ea. |

Drilling pattern for long version, overlay door

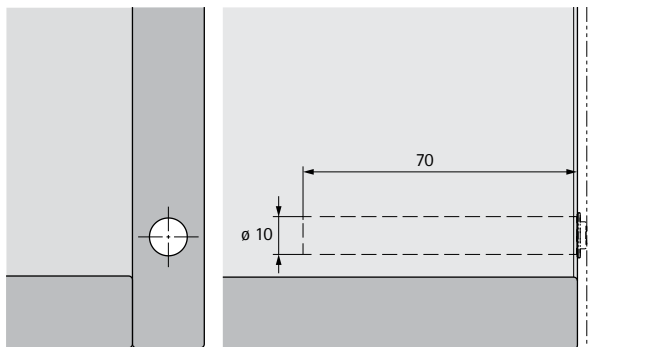

Push to open opening system for handleless furniture fronts

- ▶ Push to open Magnet for screwing on
- ▶ For hinges without self closing feature



- ▶ For use with hinges without self closing feature
- ▶ Suitable for full overlay, half overlay and inset doors
- ▶ Large adjustment range of 6 mm
- ▶ Activating gap 1.4 mm
- ▶ For using short / long versions, see „Application areas / recommended applications“, pages 122 - 123
- ▶ For installation, see installation notes, pages 135 - 137
- ▶ Plastic

Push to open Magnet



- Set comprises:
- ▶ 1 Push to open Magnet
 - ▶ 1 adapter top part
 - ▶ 1 adapter base part
 - ▶ 1 counterplate for gluing / screwing on

| Article | Order no. / colour white | PU |
|---------------|-----------------------------|--------|
| Short version | 9 089 590 | 25 set |
| Long version | 9 089 591 | 25 set |

Drilling pattern for short version, overlay door or inset door

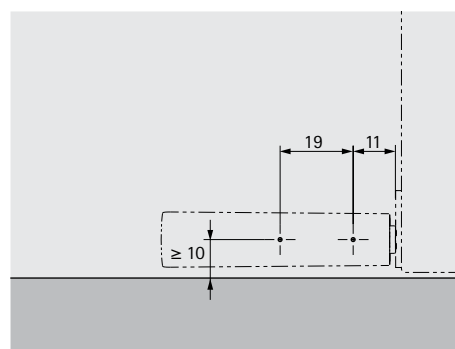
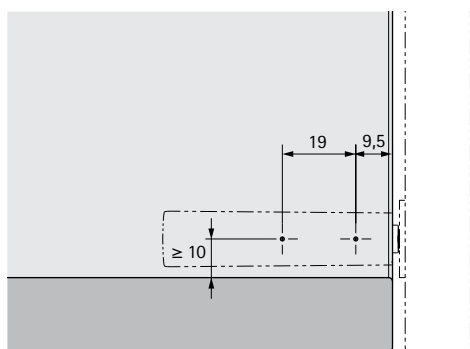

Drilling pattern for long version, overlay door or inset door

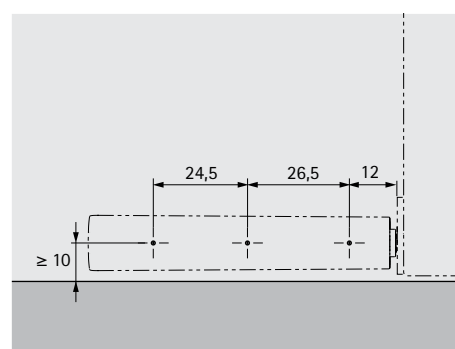
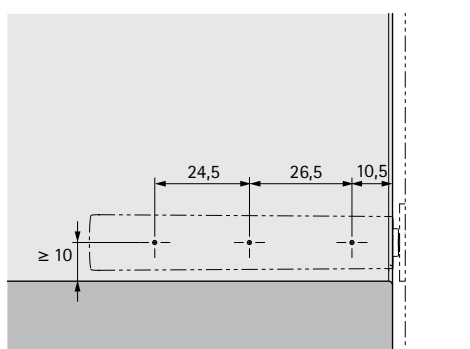

Push to open opening system for handleless furniture fronts

- ▶ Push to open Magnet for drilling in
- ▶ For hinges without self closing feature



- ▶ For use with hinges without self closing feature
- ▶ For full overlay doors
- ▶ Large adjustment range of 6 mm
- ▶ Activating gap 1.4 mm
- ▶ For using short / long versions, see „Application areas / recommended applications“, pages 122 - 123
- ▶ For installation, see installation notes, pages 135 - 137
- ▶ Plastic

Push to open Magnet



Set comprises:

- ▶ 1 Push to open Magnet
- ▶ 1 counterplate for gluing / screwing on

| Article | Order no. / colour white | PU |
|---------------|-----------------------------|--------|
| Short version | 9 089 592 | 25 set |
| Long version | 9 089 593 | 25 set |

Drilling pattern for short version, overlay door

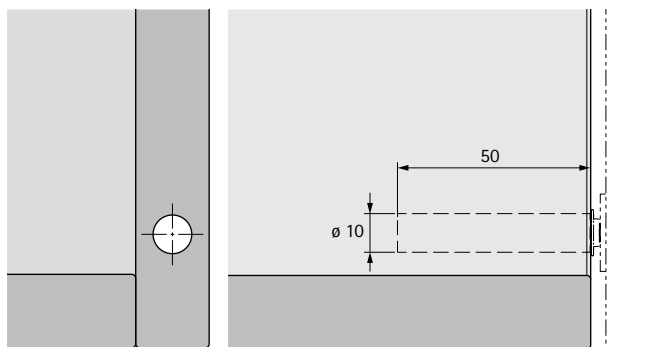

Drilling pattern for long version, overlay door

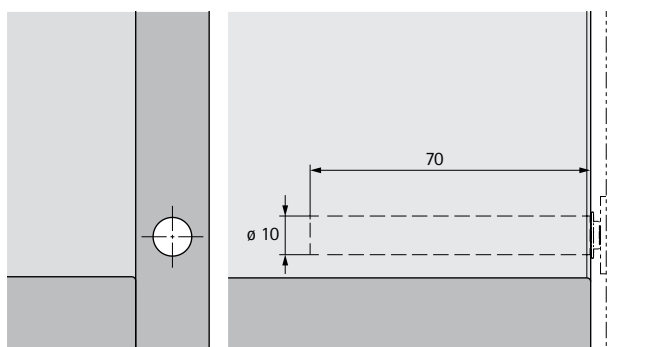

Push to open opening system for handleless furniture fronts

► Accessories

► For Push to open Pin / Push to open Magnet, for drill in versions



- High quality design adapter for upgrading furniture range
- For combination with all Push to open drill in versions
- Push to open drill in version must be ordered separately
- Suitable for full overlay, half overlay and inset doors
- Attachment housing material: plastic, anthracite
- Housing material: zinc die-cast nickel plated

Design adapter



Set comprises:

- 1 attachment housing
- 1 design adapter

| Order no. | PU |
|-----------|--------|
| 9 089 633 | 25 set |

Drilling pattern for the attachment housing for overlay or inset door with Push to open Pin

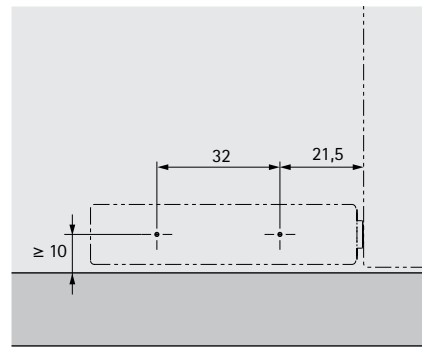
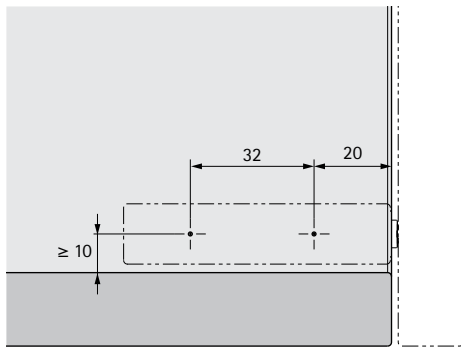

Drilling pattern for the attachment housing for overlay or inset door with Push to open Magnet

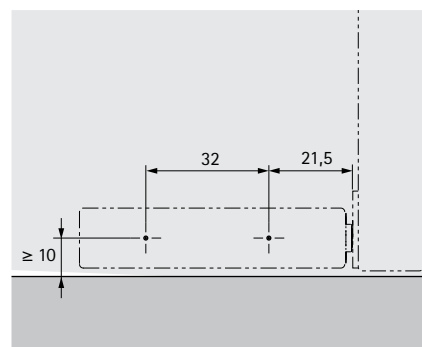
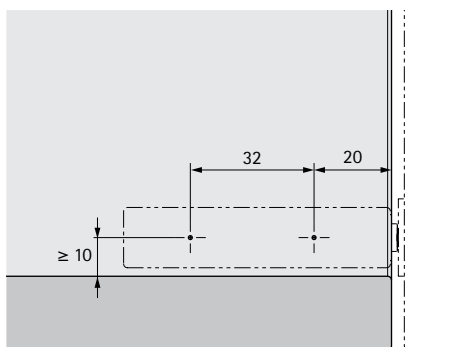

Push to open opening system for handleless furniture fronts

- ▶ Accessories
- ▶ For Push to open Magnet

Counterplate for gluing and screwing on

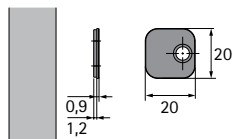

- ▶ Self adhesive type
- ▶ Mounting hole for optional countersunk screw $\varnothing 3$ mm
- ▶ Counterplate is included with all "Push to open Magnet" and "Push to open Lock" articles
- ▶ Steel

| Order no. | PU |
|-----------|---------|
| 9 090 869 | 100 ea. |

Counterplate for screwing on

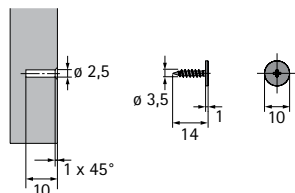

- ▶ For drilling $\varnothing 2.5 \times 10$ mm
- ▶ For use with PZ 1 screwdriver
- ▶ Steel, nickel plated

| Order no. | PU |
|-----------|---------|
| 9 090 845 | 100 ea. |

Counterplate for pressing in

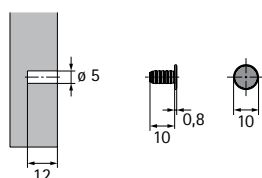

- ▶ For $\varnothing 5 \times 12$ mm drilling
- ▶ Steel, nickel plated

| Order no. | PU |
|-----------|---------|
| 9 090 846 | 100 ea. |

Push to open opening system for handleless furniture fronts

- ▶ Assembly aids
- ▶ Drilling jig for Push to open drill in versions

Drilling jig for Push to open



- ▶ For drilling the horizontal drill hole on the carcass for Push to open drill in version
- ▶ Suitable for all material thicknesses
- ▶ Drilling bush in hardened steel
- ▶ Plastic
- ▶ Drill bit and setting ring are not included

| Order no. | PU |
|-----------|-------|
| 9 207 524 | 1 ea. |

Drilling pattern for short version, Push to open Pin

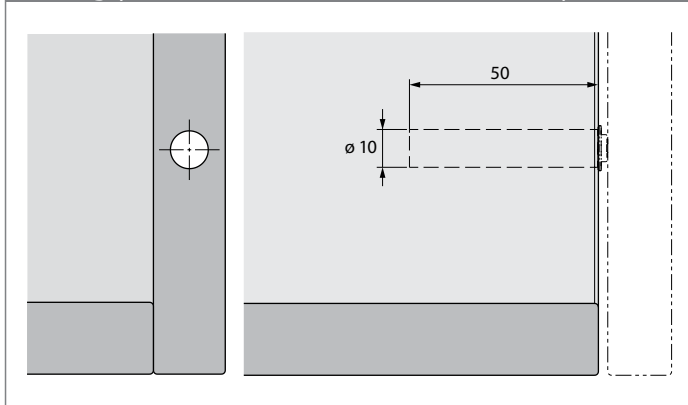

Drilling pattern for short version, Push to open Magnet

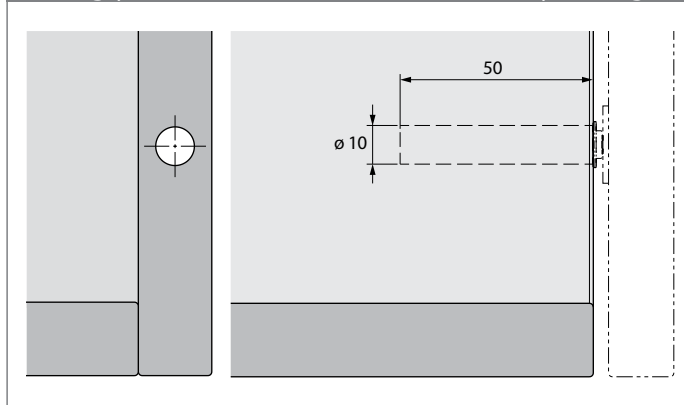

Drilling pattern for long version, Push to open Pin

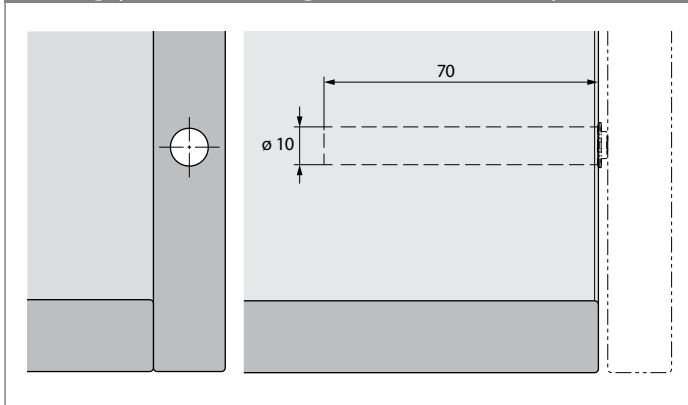

Drilling pattern for long version, Push to open Magnet

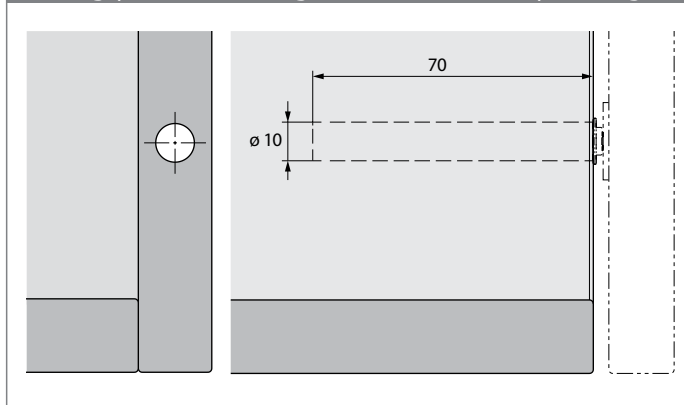



Flexibility and competency in meeting specific customer demands too

The range of special hinges provides the right fitting for particular applications, such as folding doors, refrigerator

surrounds or flaps. It is also just as easy to produce designs with thin front panel materials, front frame constructions, or cases where no cup drilling can be made.



For thin materials
Glass door hinges for overlay or inset doors.



For folding doors
Centre hinges in a variety of types.



For refrigerator surrounds
Hinge with slim arm and door-on-door slider fitting for connecting furniture and refrigerator door.



For flaps
Markant flap hinges for combining with a flap stay.

Special hinges

► Range summary



Centre hinges

120 - 121



ET 582 for refrigerator surrounds

122



Door-on-door slider fitting for refrigerator surrounds

123



Glass door hinges

124



Flap hinges

125



Optimat Plus 4 FM concealed hinge for front frame

126



Easys electromechanical opening system

128



Kamat guiding hinge

129

Special hinge

- ▶ Centre hinge
- ▶ For folding doors, opening angle 180°



- ▶ Centre hinge for folding doors
- ▶ For door thicknesses over 15 mm
- ▶ Same drilling pattern for door and side element, both elements are mounted separately
- ▶ The reveal can be infinitely adjusted from minimum reveal to + 4 mm, application is always flush
- ▶ Gradual adjustment of the pivot offset with 0 mm, 3 mm and 6 mm
- ▶ Zinc die-cast nickel plated

Centre hinge with adjustable offset pivot

| Mounting option | Order no. | PU |
|-----------------|------------------|--------|
| for screwing on | 0 046 787 | 10 ea. |
| for pressing in | 0 052 095 | 10 ea. |

Drilling pattern for screwing on / for pressing in

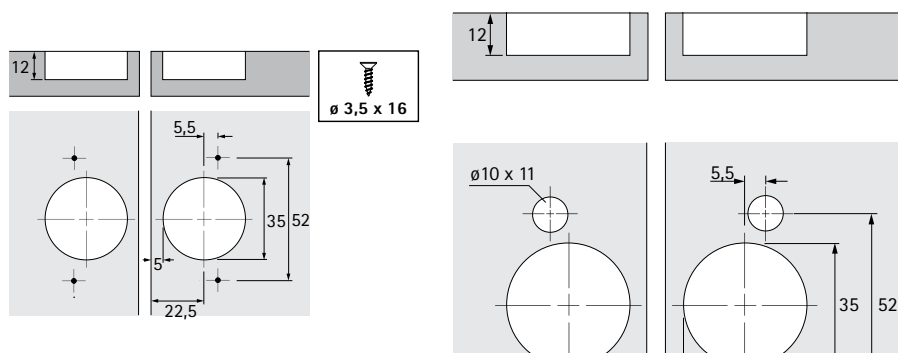

Door offset

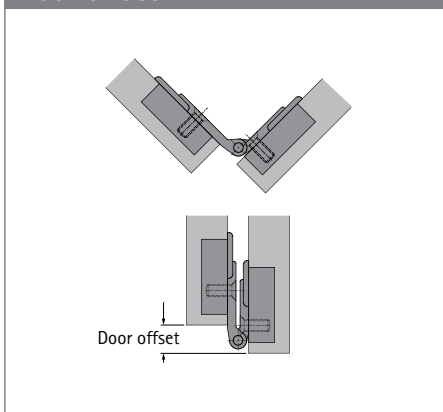

Pivot offset

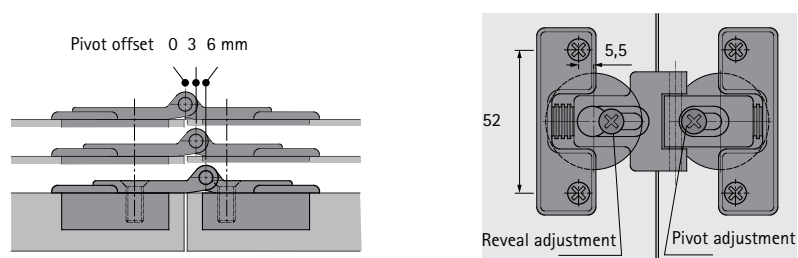

| Pivot offset mm | Door offset mm |
|-----------------|----------------|
| 0 | 0 |
| 3 | 6 |
| 6 | 12 |

By way of example for reveal = 3 mm

Special hinge

- ▶ Centre hinge
- ▶ For folding doors, opening angle 180



- ▶ Centre hinge for folding doors
- ▶ Can be installed at the centre or with pivot offset
- ▶ Top running performance due to abrasion-resistant distance rings with pivot bearing
- ▶ With fixed steel pin
- ▶ Steel, nickel plated

Centre hinge

| | |
|-----------|--------|
| Order no. | PU |
| 0 071 648 | 10 ea. |

Centred mounting

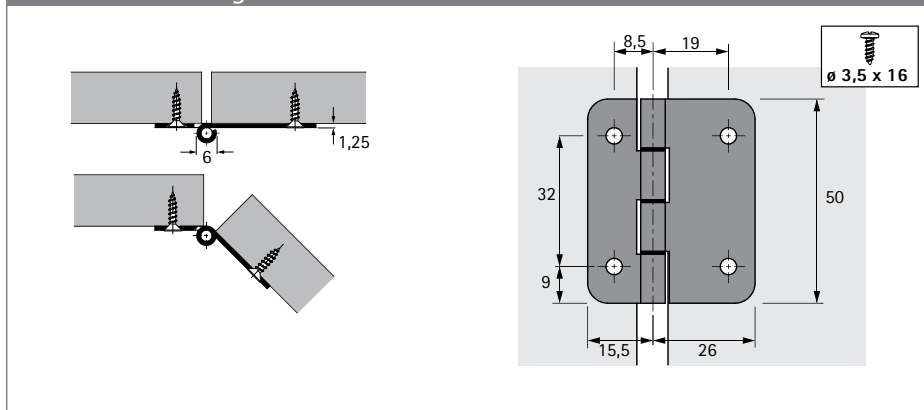

Mounting with pivot offset

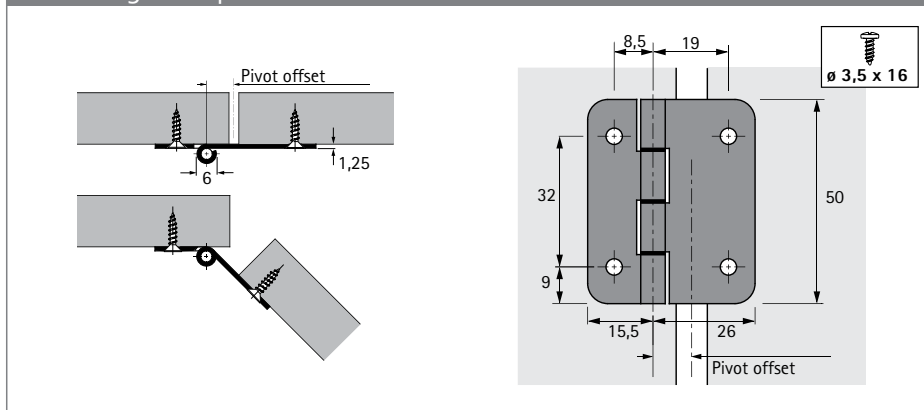

Special hinge

- ▶ ET 582
- ▶ For refrigerator surrounds, opening angle 95°



- ▶ Special hinge with short hinge protrusion for refrigerator surrounds
- ▶ Cup diameter 35 mm
- ▶ Cup depth 12.8 mm
- ▶ With stay closed function
- ▶ Including mounting plate and distance plate (distance = 3 mm) for overlays of 13 - 18 mm
- ▶ Integrated overlay adjustment + 1 mm / - 1 mm
- ▶ Integrated depth adjustment + 3 mm / - 3 mm
- ▶ Hinge arm material: nickel plated steel
- ▶ Cup hinge material: zinc die-cast nickel plated
- ▶ Distance plate material: white plastic

Special hinge ET 582

| | |
|-----------|--------|
| Order no. | PU |
| 0 072 134 | 10 ea. |

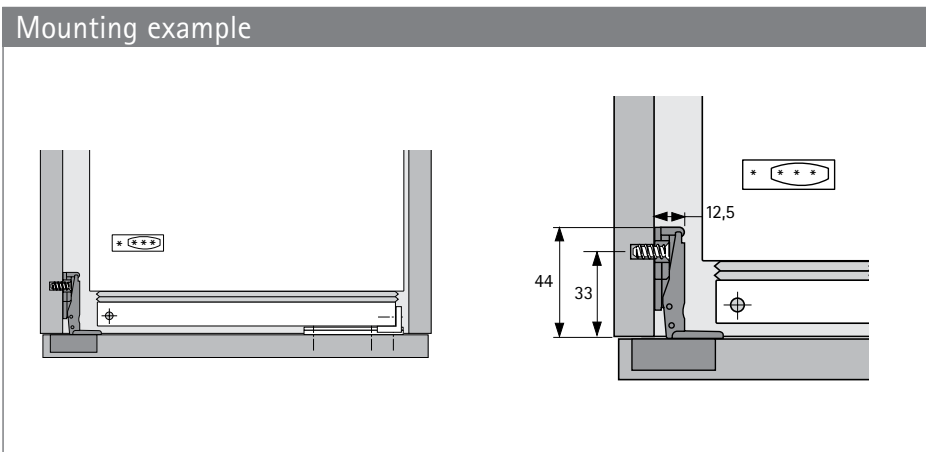
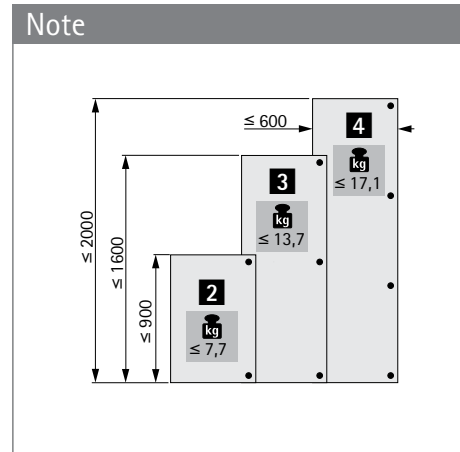
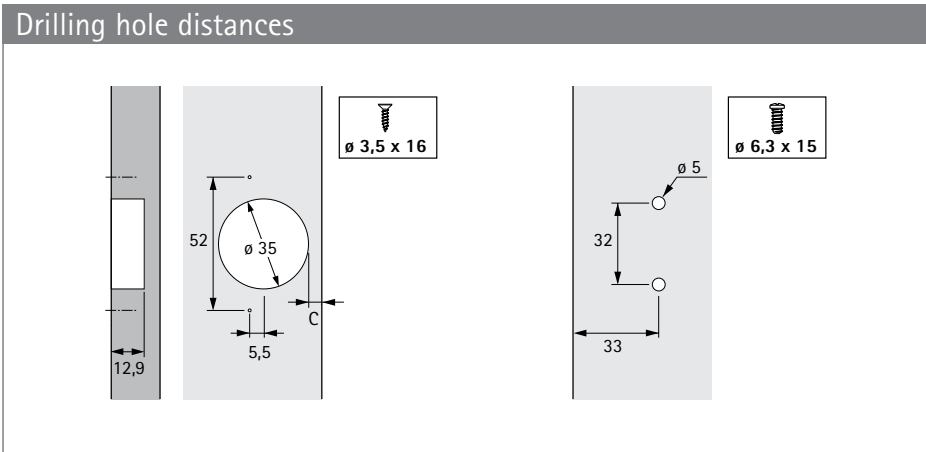

Note

A door-on-door slider fitting can be used for connecting the furniture door to the refrigerator door.

| Mounting plate with plastic distance plate = 3 mm distance | | Mounting plate without plastic distance plate = 0 mm distance | |
|--|------------|---|------------|
| Dimension C mm | Overlay mm | Dimension C mm | Overlay mm |
| 3.0 | 13.0 | 3.0 | 16.0 |
| 3.5 | 13.5 | 3.5 | 16.5 |
| 4.0 | 14.0 | 4.0 | 17.0 |
| 4.5 | 14.5 | 4.5 | 17.5 |
| 5.0 | 15.0 | 5.0 | 18.0 |

Special hinge

- ▶ Door-on-door slider fitting for refrigerator surrounds
- ▶ For hinged doors



- ▶ Suitable for built-in refrigerators
- ▶ Allows cabinet and refrigerator door to be opened simultaneously
- ▶ All-inclusive set complete with guide profile, adapter for refrigerator door and cover caps
- ▶ Plastic, white

Set comprises:

- ▶ 1 runner
- ▶ 1 cover cap for runner
- ▶ 1 adapter for refrigerator door
- ▶ 1 cover cap for adapter for refrigerator door

Door-on-door slider fitting for refrigerator surrounds

| Order no. | PU |
|-----------|-------|
| 9 079 390 | 1 set |

Installation

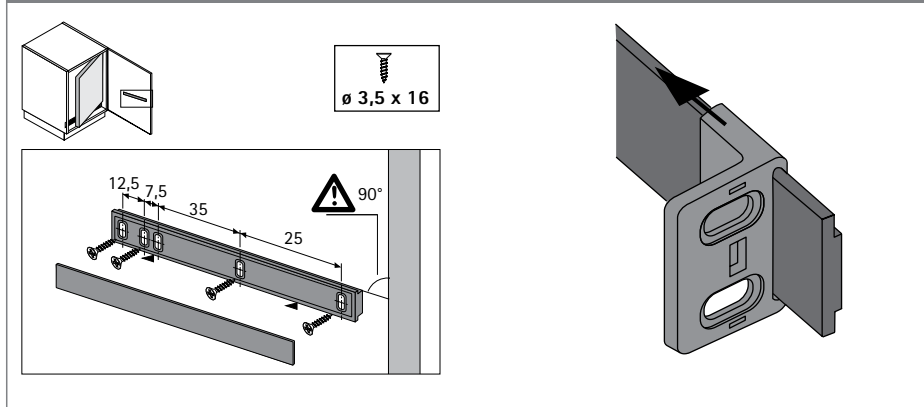

Installation

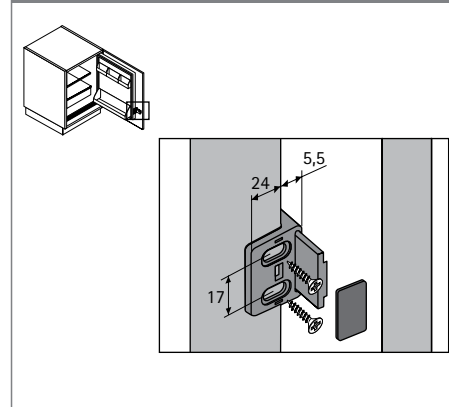

Mounting example

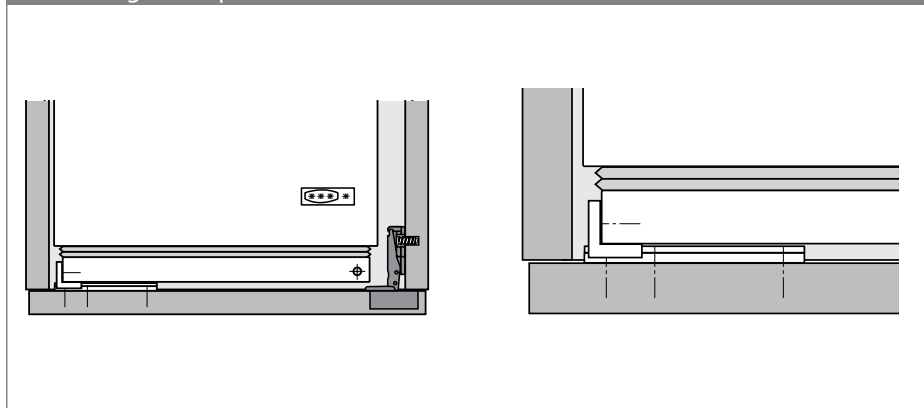

Special hinge

- ▶ Glass door hinge ET 5150
- ▶ For inset doors



- ▶ Glass door hinge with stay close function for inset doors
- ▶ 170° opening angle
- ▶ ET 5150 and glass door handle: easy installation by clamping screw, no need to drill holes in the glass
- ▶ 12 mm \varnothing hole must be drilled in the glass
- ▶ Hinge including stick on anti slip element
- ▶ Door format:
 - Height = inside carcase height - 4.4 mm
 - With glass door handle: width = inside carcase width - 5 mm
 - With other handle: width = inside carcase width - 4 mm
- ▶ Zinc die-cast, matt nickel plated

Glass door hinge ET 5150

| Article | Order no. | PU |
|--------------------------|-----------|-----------|
| Glass door hinge ET 5150 | 0 024 908 | 1/20 pair |
| Glass door handle | 0 025 314 | 1/20 ea. |

ET 5150

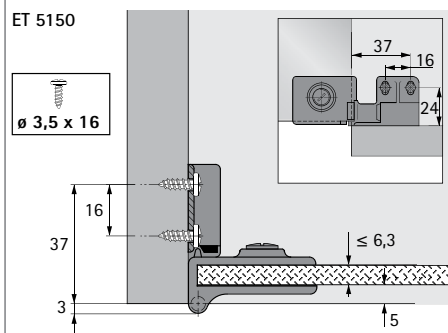

ET 5150

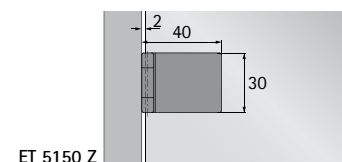

Glass door handle

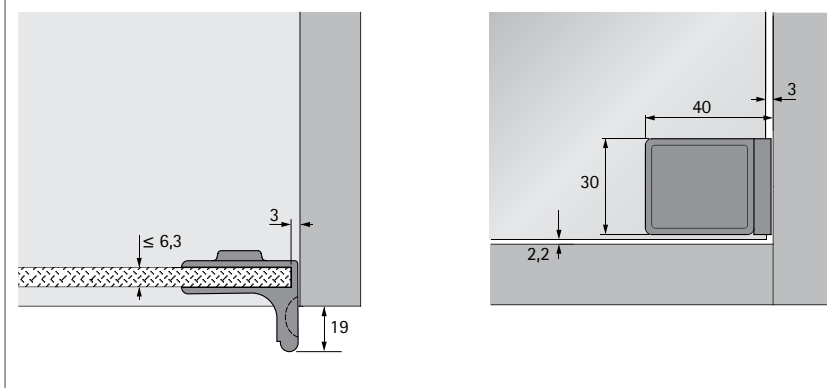

Note

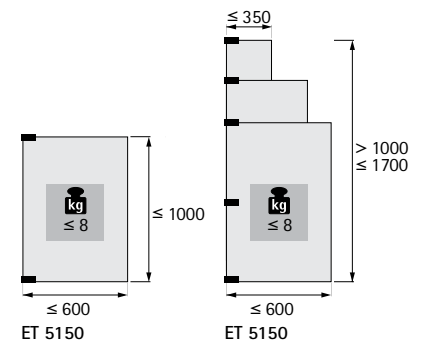

Special hinge

- ▶ Flap hinge Markant 11
- ▶ For overlay flaps



- ▶ Flap hinge for overlay flaps
- ▶ Quality classification under EN 15828, Level 2
- ▶ Separate installation of bottom panel and flap element
- ▶ Flap alignment through adjustment of height, sides and depth
- ▶ Same drilling sizes in bottom panel and flap elements
- ▶ Hole drilling concealed by rim on both parts
- ▶ Without height adjustment, bottom panel and flap are flush on the inside when open
- ▶ Can only be used in conjunction with flap stays
- ▶ Nickel plated zinc die-cast

Flap hinge Markant 11

| | |
|-----------|----------|
| Order no. | PU |
| 0 040 242 | 1/20 ea. |

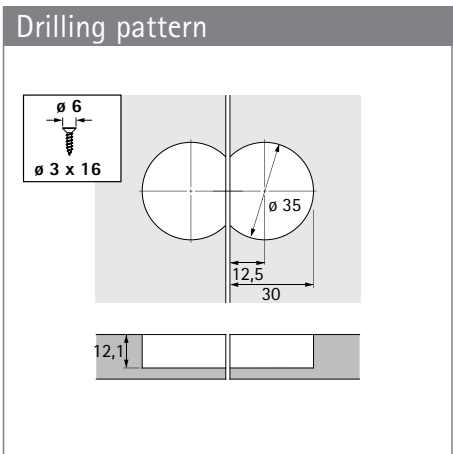
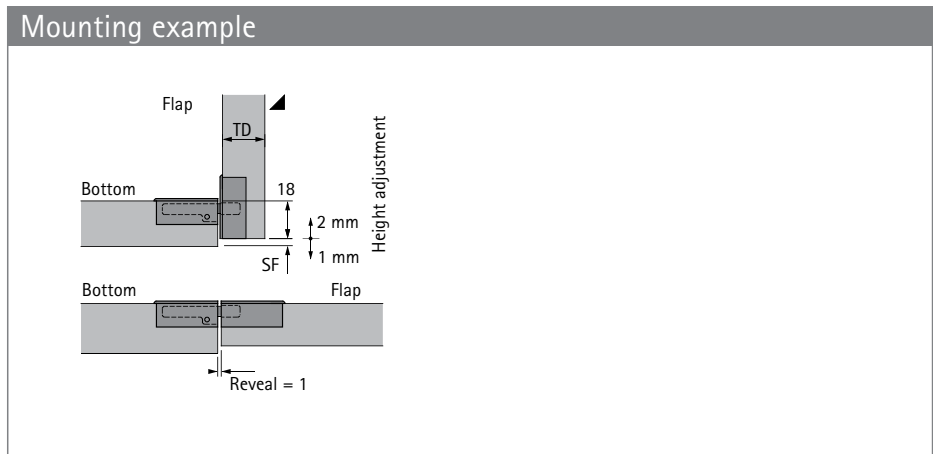

| Flap thickness TD mm | Minimum reveal SF mm |
|----------------------|----------------------|
| 16 | 1.0 |
| 17 | 2.0 |
| 18 | 3.0 |
| 19 | 3.5 |
| 20 | 4.5 |

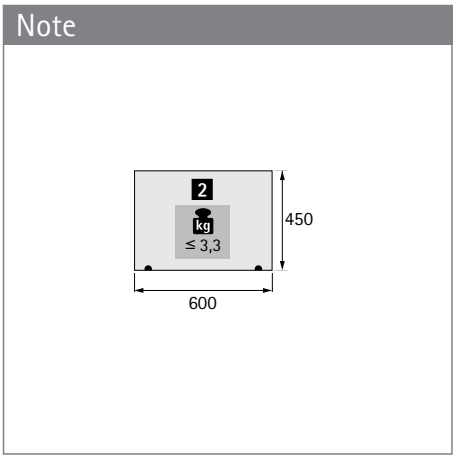

Special hinge

- ▶ Optimat Plus 4 FM
- ▶ Concealed hinge for front frame, opening angle 110°



- ▶ Suitable for all frame widths
- ▶ Quality classification under EN 15570, Level 1
- ▶ For doors over 13 mm thick
- ▶ Cup diameter 35 mm
- ▶ Cup depth 11 mm
- ▶ With self closing feature
- ▶ Door reveal at least 37 mm (hinge arm flush with the edge of the frame)
- ▶ Cup distance 2.5 mm
- ▶ Overlay adjustment + 1.5 mm / - 1.5 mm
- ▶ Height adjustment + 2 mm / - 2 mm
- ▶ Steel, nickel plated

Optimat Plus 4 FM

| | |
|-----------|----------|
| Order no. | PU |
| 9 072 548 | 1/50 ea. |

Drilling hole distances for frame / door

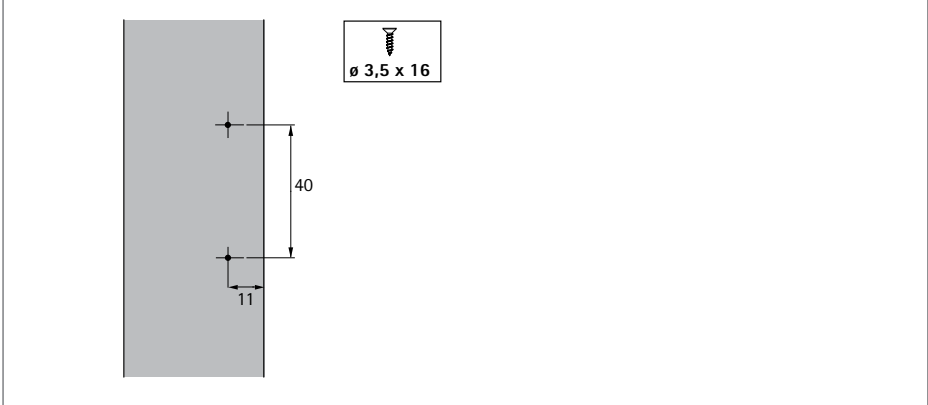

Mounting example

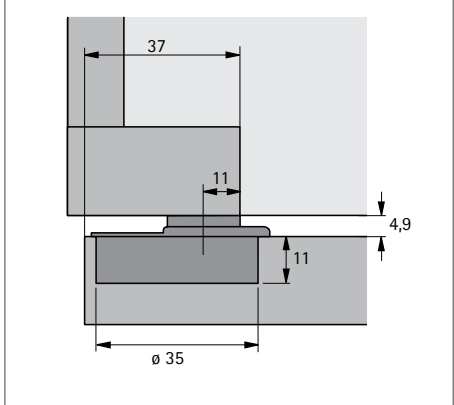

Number of hinges per door

Door format, weight and material quality are crucial factors determining the number of hinges required. The distance between the top and bottom hinge must be at least equal to the width of the door.

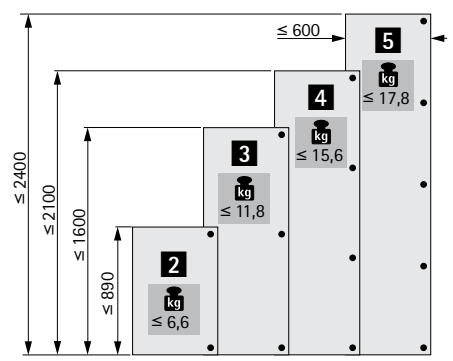

Minimum reveal per door

| Door thickness mm | Cup distance C mm |
|-------------------|-------------------|
| 16 | 2.5 |
| 19 | 4.2 |
| | 6.7 |

Electromechanical opening system for handleless furniture fronts

► Easys



Luxurious opening

Easys opens the door to handleless fronts. Easys opens the door electromechanically in response to a light press on the front. And closes it automatically after 4 to 8 seconds. Without getting fingers trapped because they are safely out

of the way. A particular advantage: the fitting is 22 mm shallow – the lowest installed height on the market. Use Easys for handleless furniture design throughout.



Handleless design throughout: Handleless design fascinates with clean looking lines and generously proportioned surfaces.



Integrate slim line elegance: At a mere 22 mm, Easys provides the lowest overall height on the market.



Reliable opening and closing: The perfected control system prevents unintentional opening. This makes power assisted closing unnecessary.

Find out more: You can get inspiration and further product details on our website.

Easys electromechanical opening system

- ▶ For refrigerators
- ▶ For screwing on



- ▶ Electromechanical opening system for refrigerators
- ▶ Quality grades in line with EN 15570, Level 3
- ▶ For installing in refrigerator surround (500 - 600 mm width)
- ▶ For attachment by chipboard screws

Easys for refrigerators



Set comprises:

- ▶ 1 Easys function unit
- ▶ 3 spacer
- ▶ 1 power supply unit
- ▶ 1 power cable with 4 different adapters (including australian option)
- ▶ 2 drilling templates
- ▶ 1 design profile
- ▶ 2 designer sockets
- ▶ 1 counterplate
- ▶ 4 tolerance plates
- ▶ 7 chipboard screws, \varnothing 3.5 x 30 mm

| | |
|------------------|-------|
| Order no. | PU |
| 9 210 848 | 1 set |

Special hinge

- ▶ Kamat guiding hinge
- ▶ For refrigerator surrounds, opening angle 115°



- ▶ For extra high furniture fronts
- ▶ For refrigerator surrounds with precision reveal alignment
- ▶ Guiding hinge for screwing on
- ▶ Can only be used in combination with Hettich K hinges
- ▶ For cabinet bodies with 19 mm or 16 mm side panels
- ▶ Installed depth 41.5 mm
- ▶ Material galvanised steel

Set comprises:

- ▶ Hinge
- ▶ Drilling template
- ▶ Spacer for 16 mm cabinet body
- ▶ Distance plates
- ▶ Cover cap, white
- ▶ Fixing screws
- ▶ Installation instructions

| Order no. | PU |
|-----------|-------|
| 9 239 784 | 1 set |

Kamat cover cap, window grey, optional



| Order no. | PU |
|-----------|--------|
| 9 248 766 | 50 ea. |

Order number index

| Order no. | Page | Order no. | Page | Order no. | Page | Order no. | Page |
|-----------|------|-----------|------|-----------|------|-----------|------|
| 0 024 908 | 124 | 1 058 365 | 68 | 9 071 658 | 91 | 9 073 705 | 17 |
| 0 025 048 | 97 | 1 058 371 | 68 | 9 072 524 | 52 | 9 073 706 | 17 |
| 0 025 204 | 96 | 1 061 347 | 82 | 9 072 525 | 52 | 9 075 009 | 90 |
| 0 025 314 | 124 | 9 043 361 | 65 | 9 072 526 | 52 | 9 075 059 | 90 |
| 0 040 242 | 125 | 9 043 262 | 86 | 9 072 533 | 93 | 9 075 108 | 64 |
| 0 040 341 | 84 | 9 043 629 | 68 | 9 072 534 | 93 | 9 075 122 | 64 |
| 0 040 495 | 84 | 9 043 640 | 64 | 9 072 535 | 93 | 9 076 440 | 94 |
| 0 041 296 | 96 | 9 043 641 | 64 | 9 072 536 | 93 | 9 079 298 | 97 |
| 0 045 036 | 86 | 9 043 642 | 64 | 9 072 540 | 94 | 9 079 390 | 123 |
| 0 045 037 | 86 | 9 043 668 | 80 | 9 072 541 | 94 | 9 079 639 | 18 |
| 0 045 169 | 96 | 9 043 669 | 820 | 9 072 548 | 126 | 9 081 657 | 95 |
| 0 046 695 | 97 | 9 043 672 | 82 | 9 072 563 | 65 | 9 082 429 | 96 |
| 0 046 787 | 120 | 9 044 823 | 86 | 9 072 569 | 65 | 9 088 016 | 36 |
| 0 047 451 | 97 | 9 071 205 | 14 | 9 072 570 | 65 | 9 088 019 | 40 |
| 0 047 452 | 97 | 9 071 206 | 14 | 9 072 571 | 65 | 9 088 021 | 46 |
| 0 048 096 | 80 | 9 071 207 | 14 | 9 073 567 | 14 | 9 088 034 | 36 |
| 0 048 097 | 80 | 9 071 208 | 14 | 9 073 568 | 14 | 9 088 037 | 40 |
| 0 052 095 | 120 | 9 071 209 | 14 | 9 073 595 | 94 | 9 088 039 | 46 |
| 0 060 576 | 100 | 9 071 210 | 14 | 9 073 612 | 14 | 9 088 057 | 46 |
| 0 060 579 | 101 | 9 071 211 | 14 | 9 073 613 | 14 | 9 088 070 | 36 |
| 0 060 581 | 99 | 9 071 262 | 16 | 9 073 614 | 14 | 9 088 073 | 40 |
| 0 070 712 | 84 | 9 071 575 | 90 | 9 073 615 | 14 | 9 088 075 | 46 |
| 0 070 713 | 864 | 9 071 576 | 90 | 9 073 616 | 14 | 9 088 085 | 40 |
| 0 071 648 | 121 | 9 071 577 | 90 | 9 073 638 | 16 | 9 088 087 | 46 |
| 0 072 134 | 122 | 9 071 578 | 90 | 9 073 640 | 16 | 9 088 100 | 37 |
| 0 072 960 | 84 | 9 071 595 | 90 | 9 073 642 | 16 | 9 088 103 | 42 |
| 0 072 967 | 84 | 9 071 596 | 90 | 9 073 643 | 16 | 9 088 123 | 48 |
| 0 072 968 | 84 | 9 071 597 | 90 | 9 073 644 | 16 | 9 088 139 | 42 |
| 0 077 699 | 80 | 9 071 598 | 90 | 9 073 645 | 16 | 9 088 141 | 48 |
| 0 077 700 | 80 | 9 071 625 | 90 | 9 073 646 | 16 | 9 088 159 | 48 |
| 0 077 708 | 82 | 9 071 626 | 90 | 9 073 665 | 17 | 9 088 179 | 43 |
| 0 077 709 | 82 | 9 071 627 | 90 | 9 073 666 | 17 | 9 088 199 | 49 |
| 1 004 895 | 97 | 9 071 628 | 90 | 9 073 667 | 17 | 9 088 215 | 453 |
| 1 029 518 | 64 | 9 071 650 | 91 | 9 073 668 | 17 | 9 088 217 | 49 |
| 1 029 520 | 64 | 9 071 651 | 91 | 9 073 668 | 19 | 9 088 229 | 49 |
| 1 030 620 | 64 | 9 071 652 | 91 | 9 073 688 | 14 | 9 088 249 | 93 |
| 1 030 622 | 64 | 9 071 653 | 91 | 9 073 695 | 16 | 9 088 250 | 93 |
| 1 030 922 | 64 | 9 071 655 | 91 | 9 073 696 | 16 | 9 088 251 | 93 |
| 1 030 924 | 64 | 9 071 656 | 91 | 9 073 697 | 16 | 9 088 253 | 96 |
| 1 031 071 | 64 | 9 071 657 | 91 | 9 073 704 | 17 | 9 089 587 | 108 |

Order number index

| Order no. | Page | Order no. | Page | Order no. | Page | Order no. | Page |
|-----------|------|-----------|------|-----------|------|-----------|------|
| 9 089 588 | 109 | 9 091 741 | 18 | 9 094 296 | 26 | 9 117 472 | 92 |
| 9 089 589 | 109 | 9 091 742 | 18 | 9 094 360 | 28 | 9 117 716 | 72 |
| 9 089 590 | 112 | 9 091 743 | 18 | 9 094 361 | 28 | 9 117 717 | 72 |
| 9 089 591 | 112 | 9 091 744 | 52 | 9 094 366 | 28 | 9 117 718 | 72 |
| 9 089 592 | 113 | 9 091 747 | 41 | 9 099 540 | 30 | 9 207 524 | 116 |
| 9 089 593 | 113 | 9 091 748 | 47 | 9 099 541 | 30 | 9 210 848 | 128 |
| 9 089 597 | 110 | 9 091 753 | 21 | 9 099 542 | 30 | 9 217 435 | 97 |
| 9 089 599 | 111 | 9 091 767 | 31 | 9 099 543 | 30 | 9 238 321 | 97 |
| 9 089 601 | 108 | 9 091 768 | 31 | 9 099 546 | 30 | 9 239 784 | 129 |
| 9 089 603 | 109 | 9 091 769 | 34 | 9 099 551 | 30 | 9 248 766 | 129 |
| 9 089 611 | 110 | 9 091 770 | 34 | 9 099 600 | 32 | | |
| 9 089 613 | 111 | 9 091 771 | 17 | 9 099 601 | 32 | | |
| 9 089 628 | 109 | 9 091 772 | 17 | 9 099 603 | 32 | | |
| 9 089 633 | 114 | 9 091 773 | 17 | 9 099 606 | 32 | | |
| 9 089 636 | 110 | 9 091 774 | 18 | 9 099 610 | 32 | | |
| 9 089 638 | 111 | 9 091 775 | 18 | 9 099 661 | 33 | | |
| 9 089 626 | 108 | 9 091 776 | 18 | 9 099 663 | 33 | | |
| 9 090 107 | 54 | 9 091 779 | 41 | 9 099 666 | 33 | | |
| 9 090 109 | 54 | 9 091 780 | 47 | 9 099 673 | 33 | | |
| 9 090 110 | 54 | 9 091 789 | 31 | 9 099 750 | 76 | | |
| 9 090 111 | 54 | 9 091 791 | 34 | 9 099 751 | 76 | | |
| 9 090 111 | 88 | 9 091 793 | 27 | 9 099 752 | 76 | | |
| 9 090 113 | 56 | 9 091 799 | 92 | 9 099 756 | 76 | | |
| 9 090 260 | 20 | 9 091 800 | 92 | 9 099 760 | 76 | | |
| 9 090 261 | 20 | 9 091 801 | 92 | 9 099 761 | 76 | | |
| 9 090 756 | 94 | 9 091 802 | 92 | 9 099 811 | 77 | | |
| 9 090 845 | 115 | 9 091 803 | 92 | 9 099 816 | 77 | | |
| 9 090 846 | 115 | 9 091 804 | 92 | 9 099 821 | 77 | | |
| 9 090 864 | 95 | 9 091 805 | 92 | 9 099 870 | 93 | | |
| 9 090 869 | 115 | 9 091 806 | 92 | 9 099 871 | 93 | | |
| 9 091 402 | 20 | 9 091 821 | 95 | 9 101 552 | 96 | | |
| 9 091 406 | 20 | 9 091 822 | 95 | 9 102 082 | 96 | | |
| 9 091 410 | 20 | 9 094 270 | 26 | 9 103 006 | 95 | | |
| 9 091 420 | 20 | 9 094 271 | 26 | 9 116 394 | 55 | | |
| 9 091 490 | 22 | 9 094 276 | 26 | 9 116 398 | 55 | | |
| 9 091 580 | 23 | 9 094 280 | 26 | 9 117 341 | 91 | | |
| 9 091 761 | 27 | 9 094 281 | 26 | 9 117 342 | 91 | | |
| 9 091 738 | 17 | 9 094 286 | 26 | 9 117 344 | 91 | | |
| 9 091 739 | 17 | 9 094 290 | 26 | 9 117 388 | 91 | | |
| 9 091 740 | 17 | 9 094 291 | 26 | 9 117 471 | 92 | | |



Hettich accepts responsibility for the world we live in. This awareness defines the strict policy of environmental management that we practise. Our environmental officer has taken personal responsibility for these aspects throughout the group of companies over a period of many years. In addition, a separate environment committee has been established for each production site. We regard statutory provisions as minimum requirements. At significant sites we also implement the stringent EMAS Regulation. And we drive forward developments that in future will help to save even more raw materials and support the necessary endeavours towards sustainability.

Hettich environmental management

In 1996 Hettich started introducing effective environmental management systems under the stringent EMAS Regulation (currently: EC Regulation No. 761/2001, including EN ISO 14.001/2004). This not only enables us to improve

our environmental performance on a broad front but also to achieve a high level of safety which, not least, also benefits our customers. This is why we also require our suppliers to meet the necessary minimum standards of environmental protection, industrial safety, health care and social welfare.

The results achieved in the drawer runner and drawer system product segment at the Kirchlengern operation illustrate the impressive effects these measures have and verifiably demonstrate our tireless endeavours to translate words into action:

Relief to the environment between 1997 and 2008:

| | |
|-----------------------------|------------|
| Specific water consumption: | 56 percent |
| Specific power consumption: | 21 percent |
| Specific heat consumption: | 84 percent |
| Specific CO2 emissions: | 29 percent |



Hettich standard for product materials

Hettich underpins its commitment by applying an internal standard for product materials. This ensures that every product – from production to disposal – satisfies all environmental requirements. Hettich products are durable. Appropriately foresighted, our rigorous standards are formulated to ensure that international legislation is also met. This provides a reliable basis for marketing furniture worldwide.

Zero energy building – Hettich Forum

The Hettich Forum building with its neutral energy balance is a shining example of future proof building design. Photovoltaic panels and solar collection system providing hot water as well as extensive roof greening and use of rain water underscore this building's overall

sustainability concept in just the same way as the broad use of cellulose insulation material from recycled newspapers, highly efficient heat recovery and the bulb free lighting concept do.

With the Hettich group of companies having acquired European Commission GreenBuilding Partner status on 5 March 2009, the comprehensive approach demonstrated by the Hettich Forum has also convinced the adjudicating panel of the national „Green Building Award 2009“. Hettich received the first prize to be presented in the „New Building“ category.

Technik für Möbel



Technical information/legal notice

General technical conditions

The fitting information, screw fixing points and load capacity information contained in this catalogue assume proper attachment using screws specified by Hettich to a chipboard panel providing a screw pull out resistance of at least 1,000 N in accordance with EN 320.

Hettich accepts no responsibility for the load capacity of furniture and its components if materials or fastening methods are used other than those stated; the furniture manufacturer must verify load capacity.

The fitting situations shown in this catalogue are only intended to illustrate the possible options.

The furniture manufacturer is responsible for ensuring that furniture is designed in compliance with standards, in particular with regard to meeting the requirements on safety.

We will be pleased to provide any further information you may require.

General Terms of Sale and Delivery

All products and services will be provided exclusively on the basis of our General Terms of Sale and Delivery published on our website at www.hettich-agb.com.

Legal notice

© Hettich Marketing- und Vertriebs GmbH & Co. KG
32278 Kirchlengern · Germany

August 2022

We reserve all rights to this catalogue under copyright law. It shall not be permissible to duplicate this catalogue in any form either in whole or in part without our written consent. Subject to technical alterations. Errors and omissions excepted. Subject to colour variations.

Order no. 9 234 457



Technik für Möbel

