

CEIT
by GSECO



NEW **F1000AC**

**A compact forklift AGV solution
for efficient load handling**

NEW F1000AC

The AGV F1000AC is a powerful counterbalance forklift designed to take your intralogistics to the next level. Its robust construction allows it to lift heavy loads directly from the floor and place them at heights of up to 1.8 meters with speed and precision.

Exceptional maneuverability, advanced 360° safety protection and on-the-spot rotation make it ideal for confined spaces, while its hydraulic lift system guarantees smooth, stable handling of diverse pallet sizes. **Fully compatible with modern fleet management solutions.**



Accurate handling

Ensures accurate load pickup and placement even in tight spaces

Lift

Hydraulic
Up to 1,800 mm
Safe and precise lifting to elevated storage or production areas

Direction of drive

Forward, backward,
on the spot rotation

Integration with Twiserion & VDA 5050

Supporting various assemblies such as robotic arms, rollers and pallet tooling

Charging

Automatic - wireless or contact

Safety

360-degree safety
Sound and light alarms
Emergency stop button



Lifting mechanism

HYDRAULIC
LIFTING HEIGHT UP TO 1,800 MM

Navigation

CONTOUR

Safety

SICK 360°

Max speed

1.6 M/S

Rated load

1,000 KG

Charging

AUTOMATIC - WIRELESS/CONTACT

Strong and resilient



In manufacturing plants, the AGV F1000AC **ensures efficient transport of heavy pallets** and materials directly from the floor to storage or production lines, supporting continuous operations and improving workflow efficiency.

Flexible and precise



In logistics and distribution centers, the **F1000AC is ideal for loading, unloading, and stacking goods up to 1.8 meters high**, making it easier to handle large volumes while ensuring safe and precise movement in confined spaces.

Modern automation



In the retail sector, it supports **automated replenishment and warehouse operations, streamlining stock handling and reducing manual labor**. This AGV represents a powerful and flexible solution for modern intralogistics.

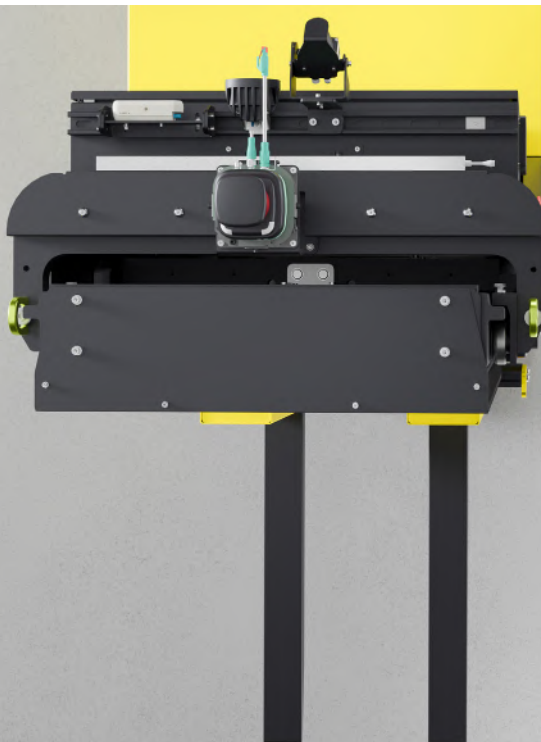

High load capacity

Fast operation

360° safety protection

Exceptional maneuverability

Integration with Twiserion & VDA 5050

Automatic wireless charging

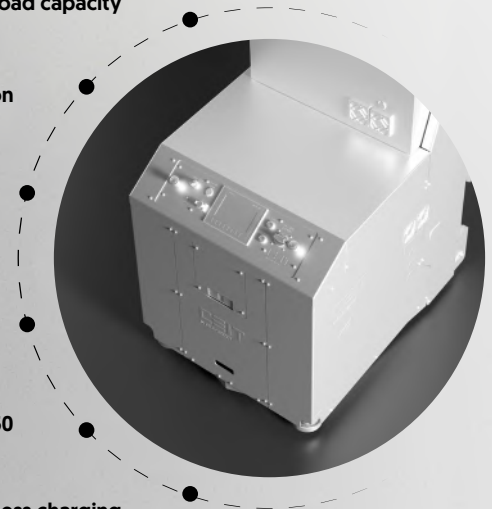

F1000AC

SPECIFICATION

Type	Forklift with counterbalance
Navigation	Contour
Direction of drive	Forward, backward, on the spot rotation
Minimal turning radius [m]:	Depending on the pallet
Max speed [m/s]:	Forward: 1.6, backward: 0.5
Load capacity [kg]:	1000
Lift	Hydraulic
Max lift [mm]	1,800
Dimensions [L, W, H in mm]	2,600x903x2,130
Batteries	Lithium
Charging	Automatic - wireless/contact
Control	Manual control - touchscreen, Universal remote control (URC)
Safety scanners:	SICK 360°

Twiserion Fleet Manager

Asseco CEIT AGVs are controlled by their own monitor & control system with **VDA 5050 standard** for guiding and monitoring logistics equipment in real time.

Twiserion Fleet Manager provides comprehensive fleet management, as well as the fleet's real-time monitoring and display of the current status and the performed request. Thanks to the collected statistical data, the customer can easily identify problem areas and focus on their optimization. **The software is also suitable for various AGV manufacturers thanks to VDA 5050 compatibility.**

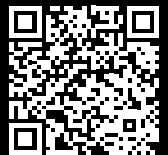

asseco-ceit.com

E-mail: sales@asseco-ceit.com