

# Profilink Speciality systems

Mini Technical catalogue





# CONTENT

<b>Opening systems without thermal break</b> _____	5
System overview _____	7
List of profiles _____	9
Profiles _____	13
<b>Sliding system without thermal break</b> _____	21
System overview _____	23
List of profiles _____	25
Profiles _____	29



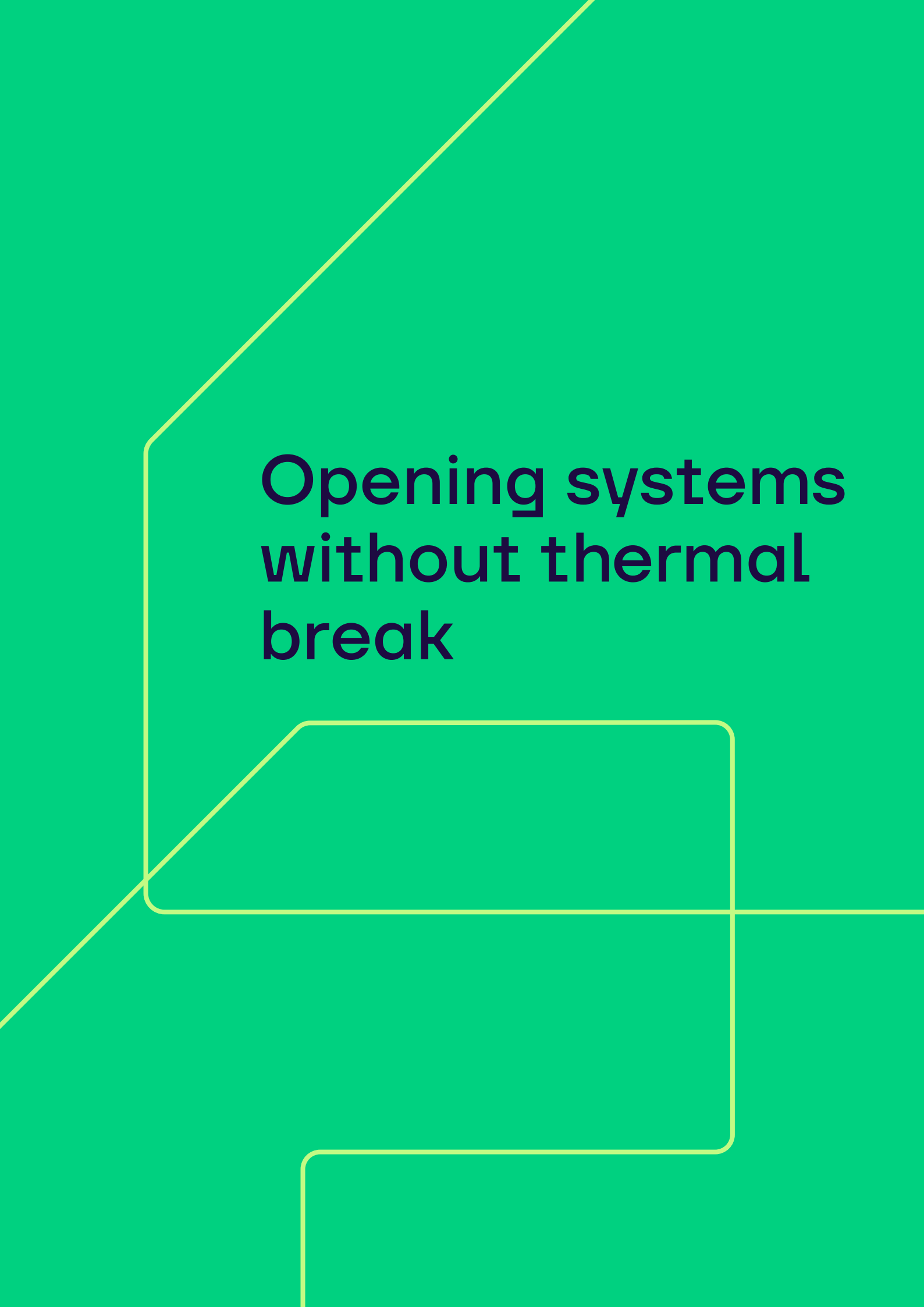

# Opening systems without thermal break



## System overview

Optimized non insulated aluminium systems for light and economical solutions for windows and doors with an excellent value for money.

Suitable for the implementation of interior doors, internal partitions and showcases. The design of the systems allows extremely fast and efficient assembly in the production of frames.

## WINDOW SYSTEM



## DOOR SYSTEM



### TECHNICAL FEATURES

- Frame parameters: W-37.5 and 74 mm, H-47 and 57 mm
- Casement parameters: W-45 mm, H-62 and 94 mm
- Glazing options: 4, 10 and 20 mm

### SURFACE OPTIONS

- All RAL colours
  - Anodizing
  - Lamination
- \* Dual colour options (different colours applied on exterior and interior profiles)

### HARDWARE OPTIONS

- EURO groove channel





The background is a solid light blue color. Overlaid on this are several abstract, geometric shapes in a bright yellow-green color. These shapes consist of straight lines and rounded corners, creating a sense of movement and depth. One prominent shape is a large, irregular polygon that frames the central text. Other shapes are scattered around, some extending towards the edges of the page.

# List of profiles



# Profilink Speciality system

Opening system without thermal break



Ideas. Engineered.

profile code	length m	perimeter mm		Ix - cm <sup>4</sup>	Iy - cm <sup>4</sup>	profile code	length m	perimeter mm		Ix - cm <sup>4</sup>	Iy - cm <sup>4</sup>
		primary	external					primary	external		
PLAWC.38.101	6.00	77 mm	244 mm	-	-	PLAWC.45.203	6.00	145 mm	379 mm	-	-

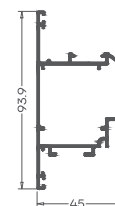
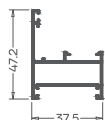

PLAWC.38.102	6.00	92 mm	265 mm	-	-	PLAWC.38.303	6.00	242 mm	717 mm	-	-
--------------	------	-------	--------	---	---	--------------	------	--------	--------	---	---

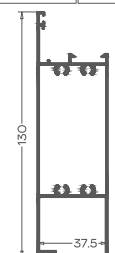
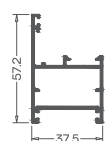

PLAWC.38.103	6.00	114 mm	333 mm	-	-	PLAWC.38.301	6.00	116 mm	465 mm	-	-
--------------	------	--------	--------	---	---	--------------	------	--------	--------	---	---

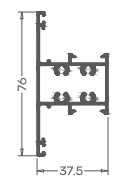
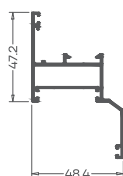

PLAWC.38.104	6.00	127 mm	346 mm	-	-	PLAWC.38.302	6.00	98 mm	322 mm	-	-
--------------	------	--------	--------	---	---	--------------	------	-------	--------	---	---

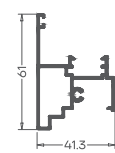
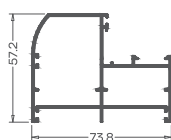

PLAWC.45.201	6.00	82 mm	312 mm	-	-	PLAAC.39.501	6.00	77 mm	157 mm	-	-
--------------	------	-------	--------	---	---	--------------	------	-------	--------	---	---

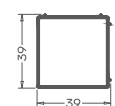
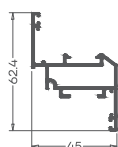

PLAWC.45.202	6.00	145 mm	379 mm	-	-	PLAAO.40.501	6.00	126 mm	126 mm	-	-
--------------	------	--------	--------	---	---	--------------	------	--------	--------	---	---

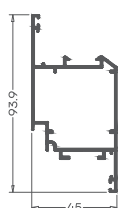

profile code	length m	perimeter mm		Ix - cm <sup>4</sup>	Iy - cm <sup>4</sup>	profile code	length m	perimeter mm		Ix - cm <sup>4</sup>	Iy - cm <sup>4</sup>
		primary	external					primary	external		
PLAAC.37.501	6.00	72 mm	142 mm	-	-	392007	6.00	-	94 mm	-	-

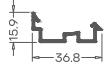

PLAAC.43.501	6.00	66 mm	260 mm	-	-	PLAAC.30.501	6.00	-	167 mm	-	-
--------------	------	-------	--------	---	---	--------------	------	---	--------	---	---

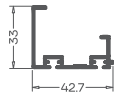

PLAGC.07.601	6.00	28 mm	131 mm	-	-	PLAWC.33.105	6.00	-	178 mm	-	-
--------------	------	-------	--------	---	---	--------------	------	---	--------	---	---



PLAGC.17.601	6.00	39 mm	146 mm	-	-	PLAAC.44.501	6.00	-	214 mm	-	-
--------------	------	-------	--------	---	---	--------------	------	---	--------	---	---

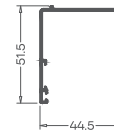

PLAGC.23.601	6.00	45 mm	160 mm	-	-
--------------	------	-------	--------	---	---



392006	6.00	-	94 mm	-	-
--------	------	---	-------	---	---





# Profiles



PLAWC.38.101

Frame

545 gr/m

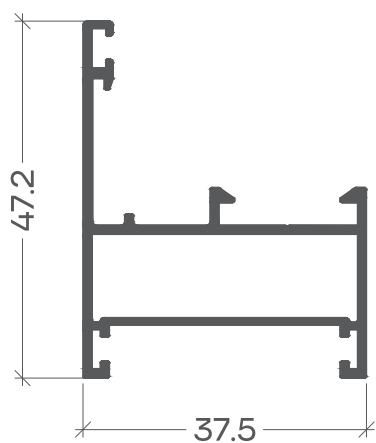

PLAWC.38.102

Frame

648 gr/m

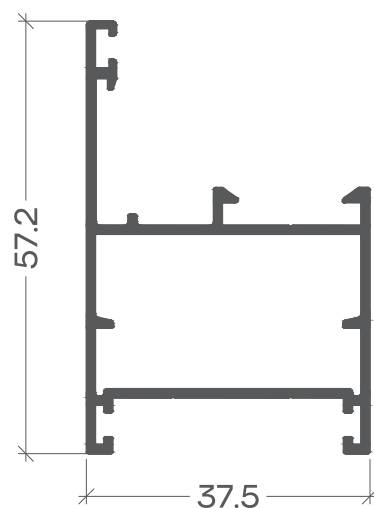

PLAWC.38.103

Frame

683 gr/m

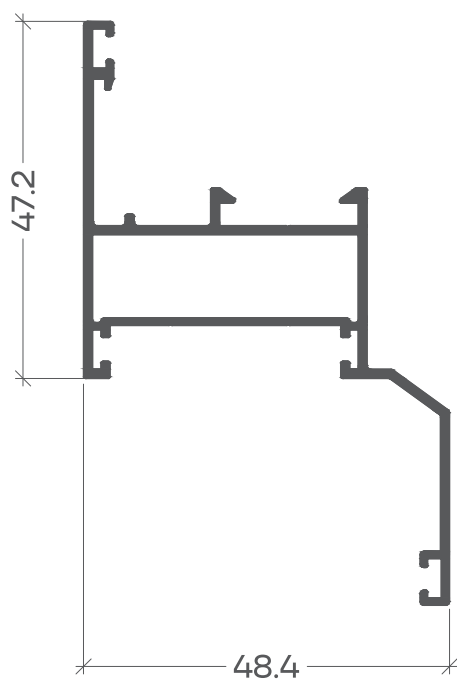

PLAWC.38.104

Frame

1093 gr/m

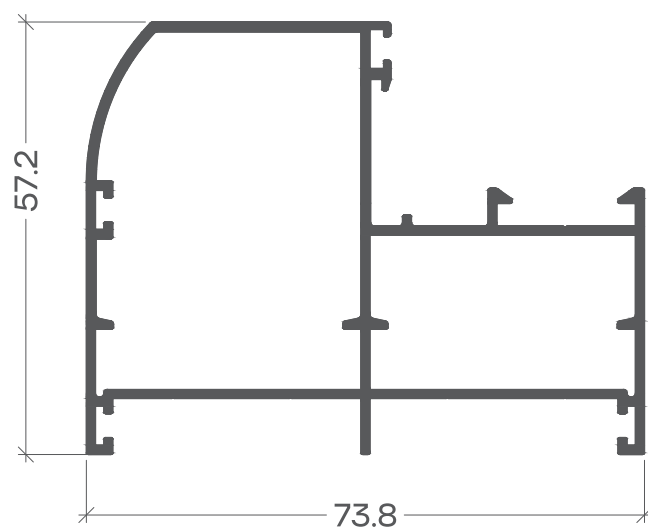

PLAWC.45.201

Sash  
694 gr/m

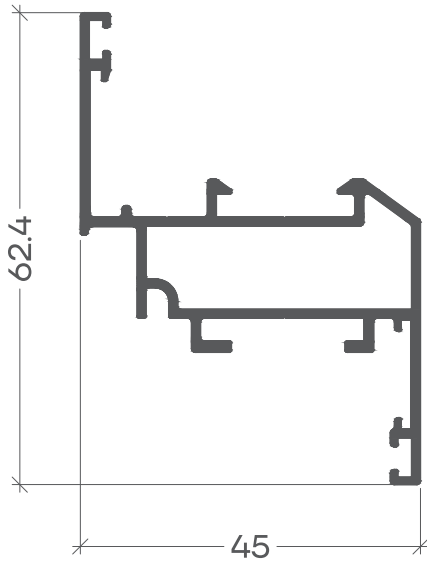

PLAWC.45.202

Sash  
964 gr/m

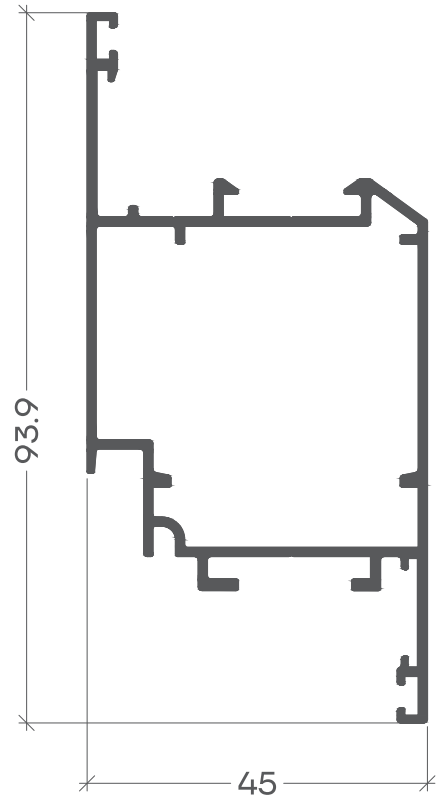

PLAWC.45.203

Sash  
967 gr/m

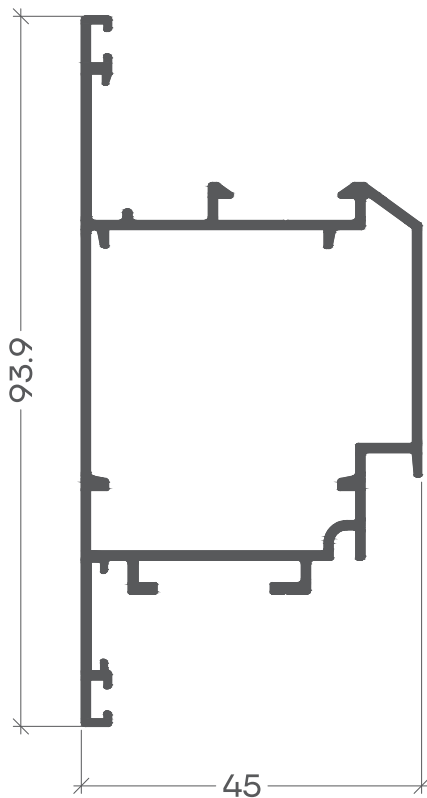

PLAWC.38.301

Mullion  
934 gr/m

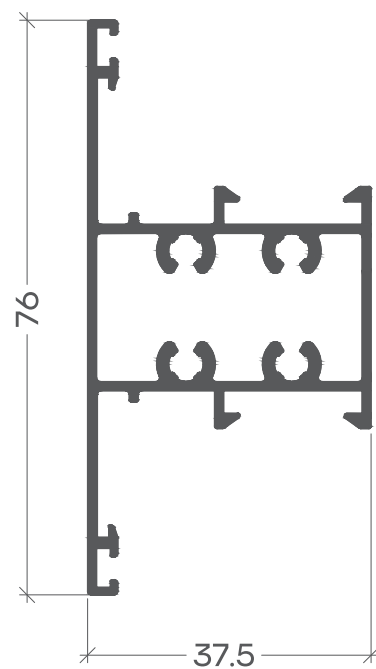



PLAWC.38.302

Overhung  
737 gr/m

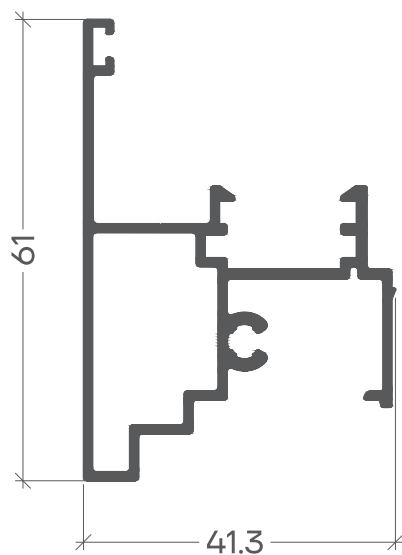

PLAWC.38.303

Kick-plate  
1350 gr/m

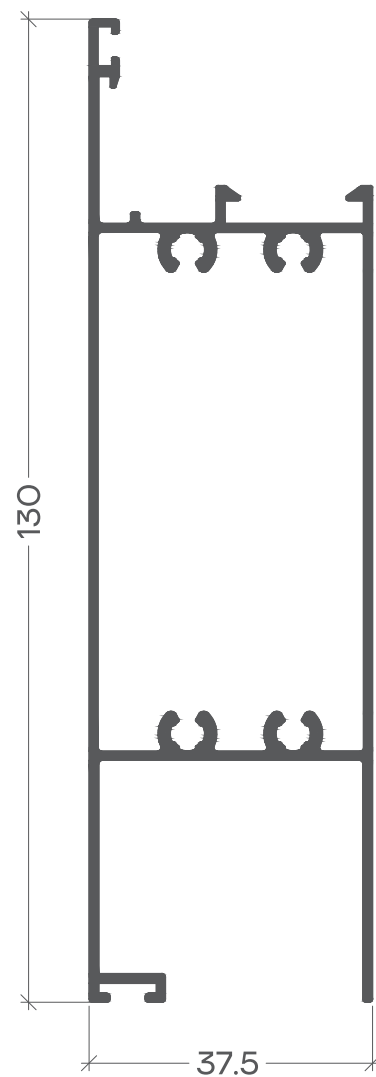

PLAAC.43.501

Ending profile  
481 gr/m

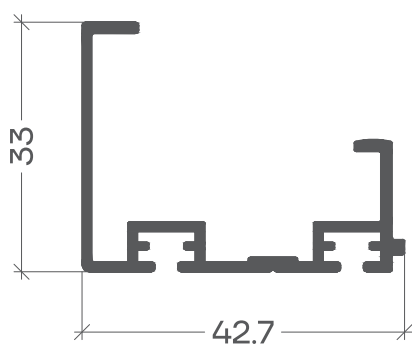

PLAAC.39.501

Column  
486 gr/m

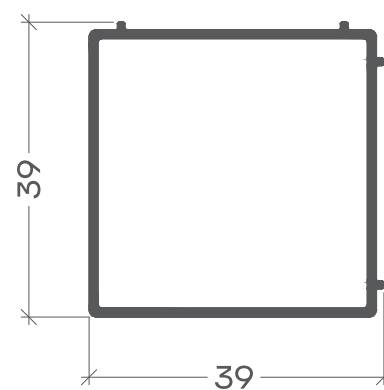

PLAAO.40.501

Pipe

394 gr/m

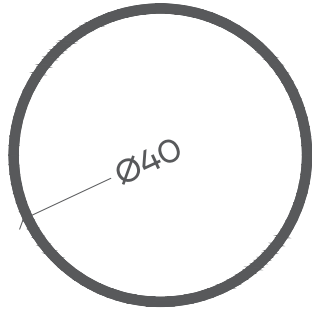

PLAAC.37.501

Adaptor

243 gr/m

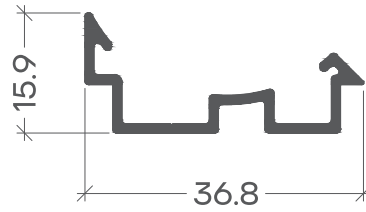

PLAGC.17.601

Glassbead

243 gr/m

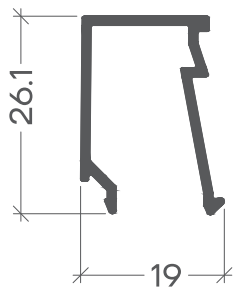

PLAGC.07.601

Glassbead

221 gr/m

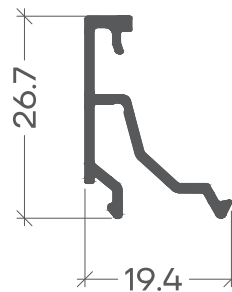

PLAGC.23.601

Glassbead

265 gr/m

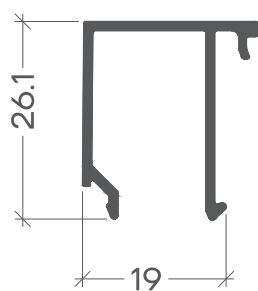

392006

fly screen window

232 gr/m

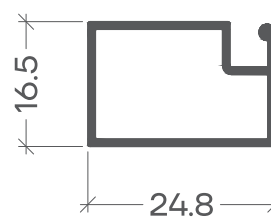

392007

fly screen door

400 gr/m

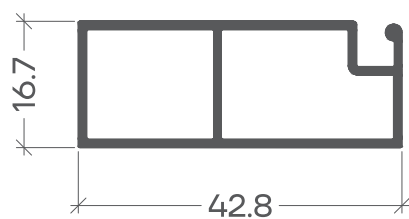

PLAAC.30.501

ending profile

281 gr/m

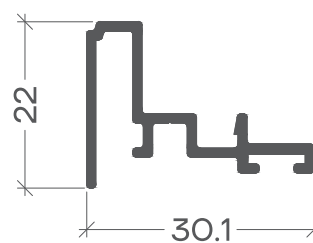

PLAWC.44.501  
wall joining profile  
365 gr/m

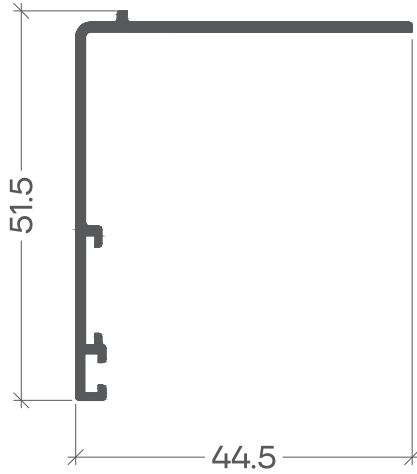

PLAWC.33.105  
threshold  
413 gr/m

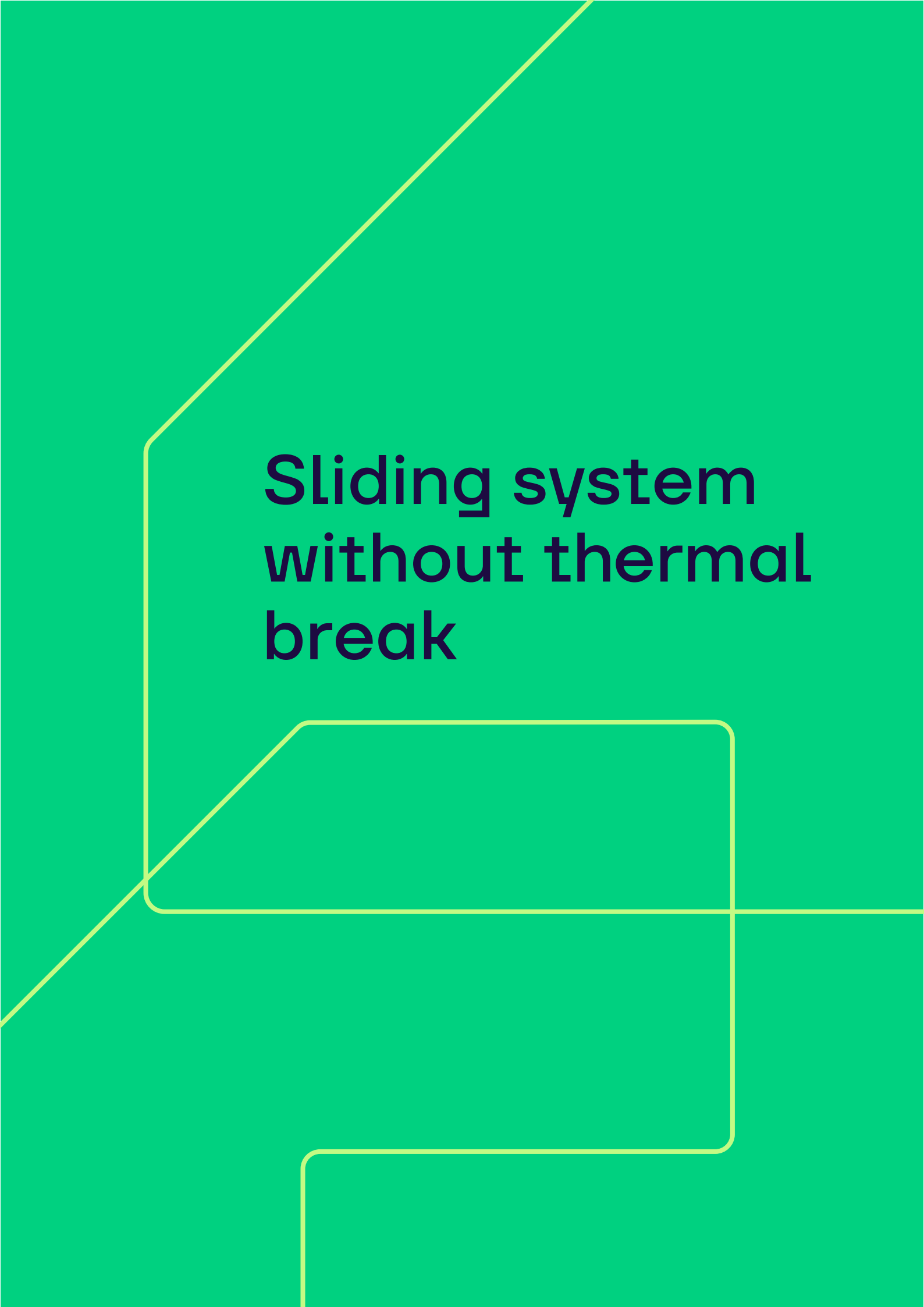

The background is a solid teal color. It features several thin, bright yellow lines that form abstract geometric shapes. One line starts from the top right and goes diagonally down to the left. Another line starts from the bottom left and goes diagonally up to the right. These two lines intersect and form a large, irregular shape that frames the text. There are also horizontal and vertical lines that create a stepped, architectural feel, with some lines having rounded corners.

# Sliding system without thermal break



## System overview

Optimized non insulated aluminum system for light and economical sliding solutions with an excellent price-quality ratio.

Suitable for the construction of internal sliding structures and also in the glazing of balconies and other rooms or spaces. It is compatible with the internal door system.



### TECHNICAL FEATURES

- Frame parameters: W-43 and 45 mm, H-38 mm
- Casement parameters: W-28 mm, H-61 mm
- Glazing options: 4, 10 and 20 mm

### SURFACE OPTIONS

- All RAL colours
  - Anodizing
  - Lamination
- \* Dual colour options (different colours applied on exterior and interior profiles)







# List of profiles



# Profilink Speciality system

Sliding system without thermal break



Ideas. Engineered.

profile code	length m	perimeter mm		Ix - cm <sup>4</sup>	Iy - cm <sup>4</sup>	profile code	length m	perimeter mm		Ix - cm <sup>4</sup>	Iy - cm <sup>4</sup>
		primary	external					primary	external		
PLASS.43.101	6.00	-	161 mm	-	-	PLASS.31.501	6.00	-	189 mm	-	-

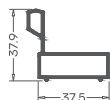

PLASS.45.101	6.00	-	204 mm	-	-	PLASS.29.501	6.00	-	134 mm	-	-
--------------	------	---	--------	---	---	--------------	------	---	--------	---	---

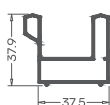

PLASS.81.102	6.00	-	336 mm	-	-	PLASS.16.501	6.00	-	78 mm	-	-
--------------	------	---	--------	---	---	--------------	------	---	-------	---	---



PLASS.28.201	6.00	-	334 mm	-	-
--------------	------	---	--------	---	---



PLASS.28.202	6.00	-	321 mm	-	-
--------------	------	---	--------	---	---

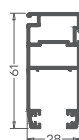

PLASS.31.501	6.00	-	189 mm	-	-
--------------	------	---	--------	---	---

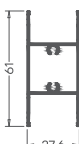



The image features a light blue background with several overlapping, rounded rectangular shapes in a vibrant lime green color. These shapes are arranged in a way that creates a sense of depth and movement, with some appearing to be in front of others. The word "Profiles" is written in a bold, dark blue font, positioned to the right of the central lime green shapes.

# Profiles



PLAWC.43.101  
frame  
508 gr/m

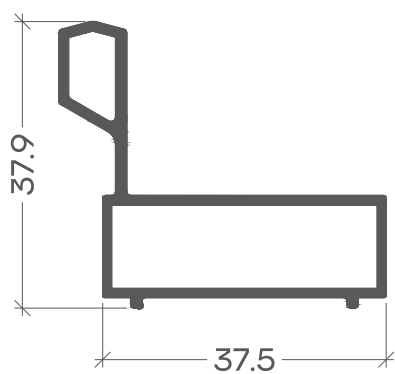

PLASS.45.101  
frame  
666 gr/m

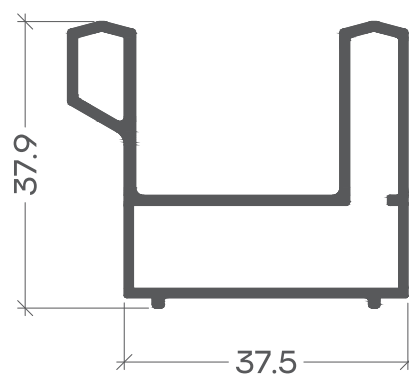

PLASS.81.102  
triple rail  
1150 gr/m

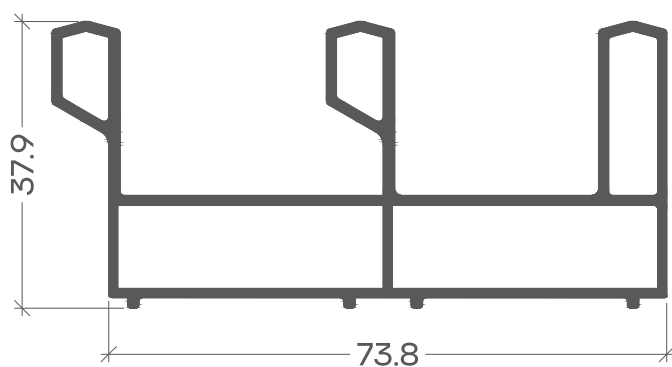

PLASS.28.201  
sash  
748 gr/m

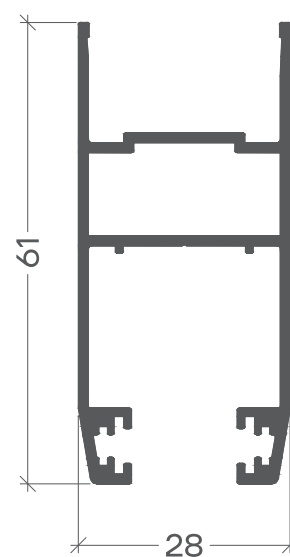

PLASS.28.202  
sash for flyscreen  
863 gr/m

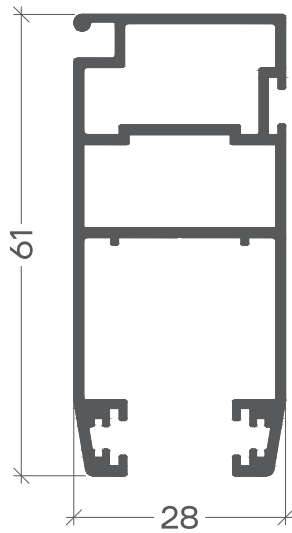

PLASS.28.301  
T-profile  
648 gr/m

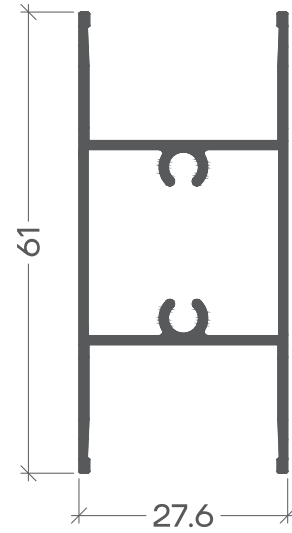

PLASS.31.501  
cap for sash  
340 gr/m

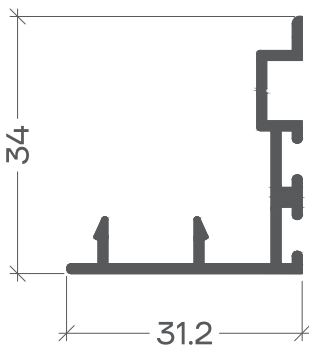

PLAWC.29.501  
adapter  
240 gr/m

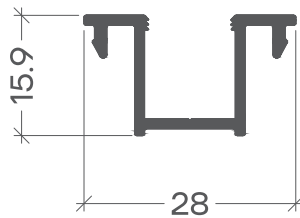

PLASS.16.501  
counter profile  
219 gr/m

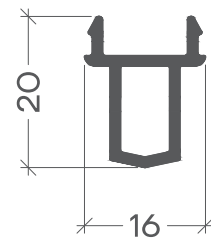





# Copyright

Copyright© 2024 LINKIN

The design, structure and content of this catalogue are subject of cop

Modifying, copying, publishing, selling or licensing any part or the whole content of this catalogue are strongly prohibited without the permission of LINKIN.

Any unauthorized use of content may violate copyright or other laws.

## Disclaimer

LINKIN is not responsible for any typographical errors, technical inaccuracies and following changes of the content of this catalogue.



