

CD100M Dri-Prime® Pumps

CD100M



The Godwin Dri-Prime 4 inch (100mm) CD100M automatic priming centrifugal pump is a highly maneuverable portable trash pump with flow capabilities to 750 gallons per minute (47 liters per second), total dynamic heads to 115 feet (35 meters) and solids handling to 2 inch (50mm) in diameter. The unique Godwin venturi air evacuation system allows the CD100M to prime from dry conditions with suction lifts up to 28 feet (8.5 meters). Perfect in intermittent flow situations, the CD100M can run dry indefinitely without damage due to the oil bath mechanical seal design. For sewer bypass, general dewatering, and many other applications, the Godwin CD100M with 4 inch (100mm) hoses is a powerful, yet versatile and portable pumping system.

Features

- Close coupled centrifugal pump with vacuum priming compressor mounted to a diesel engine. Also available in electric drive or as bare shaft pumpend.
- All cast iron construction with cast chromium steel impeller.
- Extensive application flexibility — will handle raw sewage, slurries and liquids with solids up to 2 inch (50mm) in diameter.
- Recessed impeller version available handling solids in excess of 2-3/16 inch (56mm) in diameter.
- Continuously operated “Godwin” air ejector priming device requiring no form of periodic adjustment or control.
- Dry running, high pressure oil bath mechanical seal with abrasion resistant solid Silicon Carbide interfaces.
- Solids handling ball type Non Return Valve with renewable flexible rubber seat and quick release access feature.
- Compact unit mounted on skid base or two wheeled highway trailer both incorporating integral overnight running fuel tank.
- Simple maintenance — normally limited to checking engine and seal cavity oil levels.
- Standard engine — Yanmar 3TNV88 or Caterpillar 3013C. Available with a variety of engines including Hatz, Perkins and Deutz.
- A variety of silenced sets are available.

SOLD BY



AQUOSIS
FLUID SOLUTIONS

info@aquosis.com
1.877.907.7852

CD100M Performance Curve

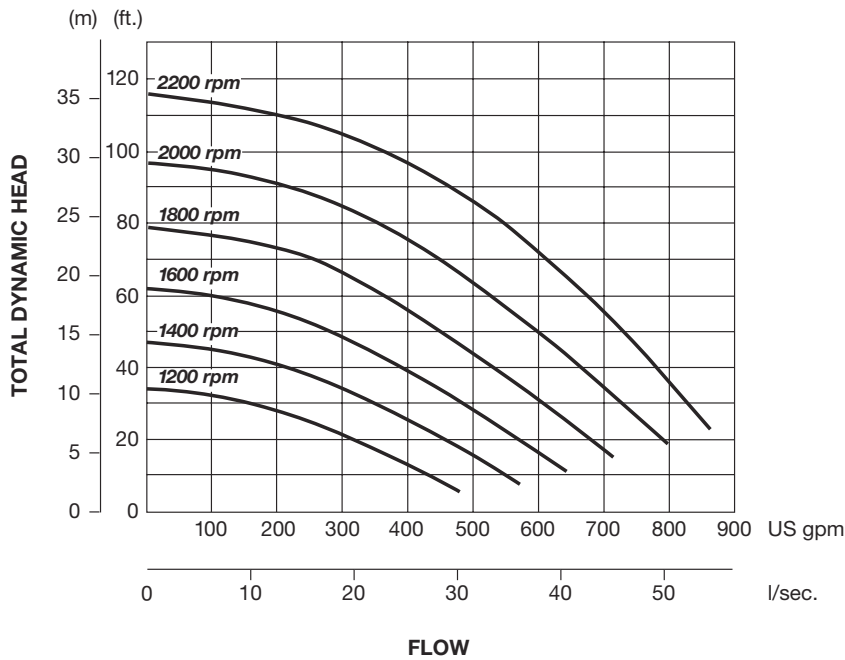

CD100M Performance Table

Diesel Set — Yanmar 3TNV88, 24 hp @ 2200 rpm
 Caterpillar 3013C, 28 hp @ 2200 rpm
Impeller Diameter — 8-5/8 in. (220 mm)

Total Suction Head - Feet	Total Delivery Head — Feet				
	10	20	30	40	50
	Output — GPM				
10	720	710	700	695	690
15	615	580	530	500	450
20	510	490	475	430	375
25	450	440	400	390	350

Performance data listed in table and curves are based on water tests at sea level and 68° F (20° C). Larger diameter pipes may be required for maximum flows.

Dimensions

CD100M — Yanmar 3TNV88, GP30 Highway Trailer
 Weight: 1734 lbs. (788 kg.)

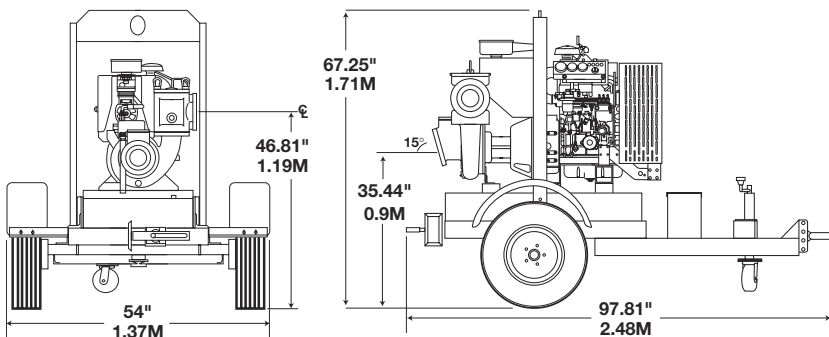

Specifications

- Maximum Operating Speed:**
2200 rpm
- Maximum Operating Temperature:**
+212° F (100° C)
- Maximum Working Pressure:**
50.0 psi (3.4 BAR)
- Maximum Suction Pressure:**
40 psi (2.8 BAR)
- Maximum Casing Pressure:**
75.0 psi (5.2 BAR)
- Fuel Tank Capacity:**
30 to 100 gallons (30 gallon standard)
(113.5 to 378.5 liters)
- Fuel Consumption** (full load, max. speed):
Yanmar: 1.21 gph (4.58 lph) @ 2200 rpm
CAT: 1.67 gph (6.32 lph) @ 2200 rpm
- Pipe Connections:**
4" (100mm) ASA 150#
- Solids Handling:**
2" (50mm) dia. standard impeller
2-3/16" (56mm) dia. recessed impeller

Materials

- Pump Casing, Suction Cover, Separation Tank and Wearplates:**
Close grained cast iron
- Impeller:**
Cast chromium steel hardened to minimum Brinell 341 HB
- Shaft Sleeve and Shaft:**
1-1/2% nickel/chromium steel
- Non Return Valve Body:**
Close grained cast iron
- Non Return Valve Ball and Seat:**
High nitrile rubber
- Mechanical Seal Faces:**
Solid Silicon Carbide



Aquatech has two facets to help you with your site specific needs.

For all your Rental and Sales needs call
Aquatech Pump and Power
 Phone: 905-907-7852
 Fax: 905-907-1701

For full "turn-key" contracting solutions call
Aquatech Dewatering Company
 Phone: 905-907-1700
 Fax: 905-907-1701

Email us: info@aquatd.com
 69 Connie Crescent/Concord, ON L4K 1L3
 www.aquatd.ca

Dri-Prime® and the color orange for pumps are registered trademarks of Godwin Pumps of America, Inc. Specifications and illustrations are subject to revision without notice. © Copyright 2003-2005 Godwin Pumps of America, Inc.

SOLD BY

