

ROLLSROLLER®
— **FLATBED APPLICATOR** —

ROLLSROLLER®
AMBASSADOR
2024 PRODUCT CATALOGUE
WELCOME TO
OUR WORLD
SIGN PRODUCTIVITY THAT IMPRESSES!

NEW SERIES
SIGNATURE



For enquiries contact your local Spicers representative.
1300 132 644 | SPICERS.COM.AU



CONTENTS

3	Application areas
4	Increase your profits
5	Choose the right ROLLSROLLER®
6-7	Explore ROLLSROLLER®
8-9	ROLLSROLLER® Signature
10-11	ROLLSROLLER® Signature Plus
12-13	ROLLSROLLER® Premium
14-15	ROLLSROLLER® Inventor edition
16-17	ROLLSROLLER® Traffic
18-19	ROLLSROLLER® Customized
20-21	5 Reasons to choose ROLLSROLLER®
20-21	Why the ROLLSROLLER® traverse/gantry make your flatbed applicator stand out from others!
22	Flatbed applicator- Technical values
23	ROLLSROLLER® academy
24-25	Self healing cutting mats
26-27	Cutting equipment
28-29	Accessories
30-31	Upgrade the ROLLSROLLER®

ROLLSROLLER®
— FLATBED APPLICATOR —

SIGN PRODUCTIVITY THAT IMPRESSES

THE ORIGINAL SIGNMAKING FLATBED APPLICATOR
THE SUPER-FAST ROLLSROLLER® FLATBED APPLICATOR PRODUCTION METHOD ELIMINATES SEVERAL TIME CONSUMING STEPS FOR SIGN MAKING AND PRINT FINISHING IN MOUNTING, LAMINATION AND PRE-MASKING.

ROLLSROLLER® Flatbed Applicator has revolutionized the finishing work of many sign makers. Using manual processes for sign making can make it difficult to meet your customer's growing demands. Many of the manual procedures are strenuous, time consuming and demanding – and results can vary. ROLLSROLLER® Flatbed Applicator gives you perfect results in a third of the time. Change to the ROLLSROLLER® production method today.

APPLICATION AREAS



MOUNTING

ONE OPERATOR CAN MOUNT LARGE FORMAT digital print and self-adhesive film to many substrates like acrylic, rigid boards, corrugated plastic, metal plate, banners and glass. The flatbed gives you complete control over positioning and produces a result free from bubbles and creases.

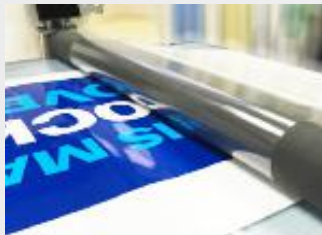

LAMINATION

DESIGNED FOR COLD FLATBED LAMINATION OF digital prints and signs, by using pressure sensitive lamination film direct from roll or sheet by sheet for minimum waste. Heat assist roller is available as option.



PRE-MASKING

IT ENABLES A SINGLE PERSON TO APPLY transfer tape to cut vinyl graphics from the built in tape roll holder.



WORK TABLE

YOU NEED NO FURTHER CUTTING TABLE. ROLLSROLLER® will become your new work table, with a unique and self-healing cutting mat.

INCREASE YOUR PROFITS

WANT TO SEE HOW MUCH TIME AND MONEY YOU CAN SAVE?

While getting access to a technology that will revolutionize your entire work process?

- Consistent high quality
- Great time savings
- Ergonomic and easy to use, does not require specialized personnel to operate.
- Fewer reproductions

AN EXAMPLE

EXAMPLE OF TYPICAL SIGN COMPANY CHANGING TO ROLLSROLLER® PRODUCTION METHOD™ SAVES €20.448,00 = 852 HRS PER YEAR.

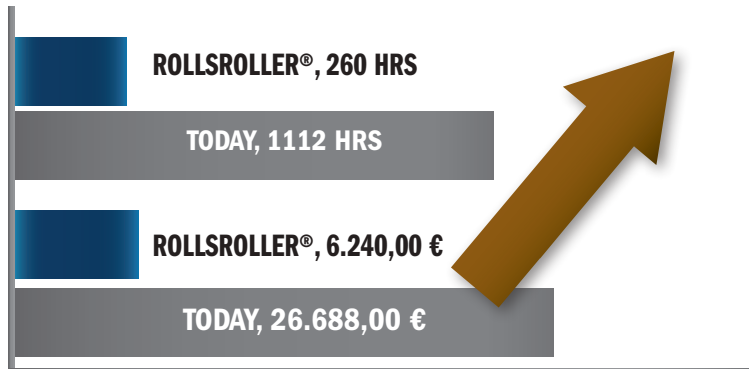

CALCULATE YOUR ROI

WANT TO SEE HOW MUCH TIME AND MONEY YOU CAN SAVE?

The ROLLSROLLER® ROI Calculator easily calculates how much you earn on replacing your traditional approach to the unique ROLLSROLLER® Flatbed Applicator method.

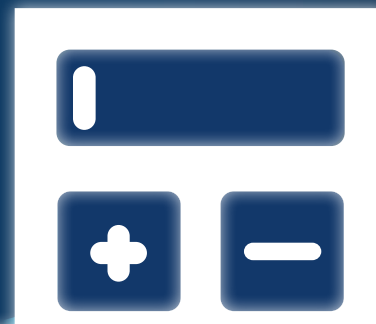

ROI Calculator



ROI Calculator
ROLLSROLLER.COM/CALCULATOR

CAN YOU AFFORD NOT TO?



Matthew Lavery, Sales Executive at Spectra Advertising

“The ROLLROLLER table has become a game changer here at Spectra Advertising and quite possibly the best piece of equipment we have invested in, to date.”

As a modern sign company, we have always considered ourselves trend setters doing what is needed to keep up with the demands and ever-changing technical aspects of our industry.

Our fabricators have always dreamt of owning a proper sign flatbed applicator because needless to say, the plywood tables we had custom built 8 years ago were not effective anymore.

Not to mention a complete eye sore to anyone entering into our facility. We entered 2023 with the commitment to become more efficient and this is where our relationship started with ROLLROLLER. This flatbed applicator is amazing.

Its modern sleek look and functionality make it the perfect application table. Not only does this table help us maximize space but has made our fabrication team more efficient.

For anyone looking to upgrade their shop and take it into the future, the ROLLROLLER flatbed applicator is a key addition and will prove to be money well spent.

We at Spectra could not be happier and we highly recommend you look into this product, so your shop can reap the benefits as well.”

- Matthew Lavery, Sales Executive at Spectra Advertising

ROLLROLLER®
— FLATBED APPLICATOR —

CHOOSE THE RIGHT ROLLROLLER®

30 DIFFERENT STANDARD MODELS

IT'S EASY TO FIND THE RIGHT ROLLROLLER FOR YOUR NEEDS. There are four* models: SIGNATURE, SIGNATURE PLUS, PREMIUM and INVENTOR EDITION. The main difference between them is the **size of the working area and the accessories included.**

SIGNATURE is your first step in to the unique ROLLROLLER production method. It's the perfect option if you have limited space and don't need any additional equipment. Both SIGNATURE PLUS and PREMIUM have illumination (LED) as standard, where PREMIUM also has side trays for big banner side feeding, more accessories and modifications available.

*Actually, there are five models. The fifth model, TRAFFIC, is specially designed for making road signs. For more information about this model, visit:

www.rollroller.se/traffic

EXPLORE ROLLSROLLER®

ROLLSROLLER® SIGNATURE

Fast setup and low investment cost



FEATURE CHART SIGNATURE

ROLLSROLLER® Quality work station	✓
Original Cutting mat	✓
Optimized media holder on short side	✓
Multidirectional media holder on glide beam	✓
Casters-movability	✓
Solid welded steel chassis	✓
Side trays	✓
Powerful and ergonomic glide beam	✓
Customized sizes available	✓
ROLLSROLLER® warranty 5 years	✓
Shipped fully assembled (Plug & Play)	option
Illuminated LED table- (dimnable)	option
Additional glide beam with roller	option
Air blow gun	option
EXC KeenCut EVO 3	option
VinylRemover	option
Additional roll holder short side	option
Oil free Compressor	option

ROLLSROLLER® SIGNATURE PLUS

The perfect match for the modern sign shop



FEATURE CHART SIGNATURE PLUS

ROLLSROLLER® Quality work station	✓
Original Cutting mat	✓
Optimized media holder on short side	✓
Multidirectional media holder on glide beam	✓
Casters-movability	✓
Solid welded steel chassis	✓
Side trays	✓
Powerful and ergonomic glide beam	✓
Customized sizes available	✓
ROLLSROLLER® warranty 5 years	✓
Quick and easy installation	✓
Illuminated LED table- (dimnable)	✓
Integrated USB A + C charging station	✓
Advanced electrical height adjustment	✓
Additional glide beam with roller	option
Antistatic system	option
Air blow gun	option
EXC KeenCut EVO 3	option
VinylRemover	option
Additional roll holder short side	option
Heat assisted roller 40°C-60°C / 104°F-140°F	option
R-Drive (motorized glide beam)	option
Extended roller adjustment. Enables substrates up to 110 mm (4in.)	option
Oil free Compressor	option

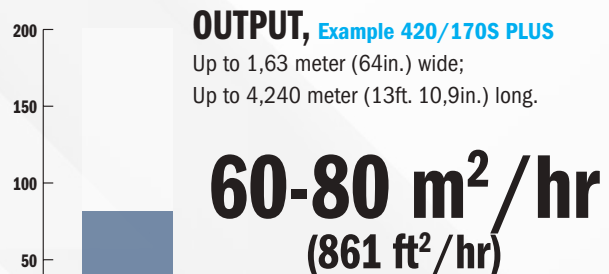
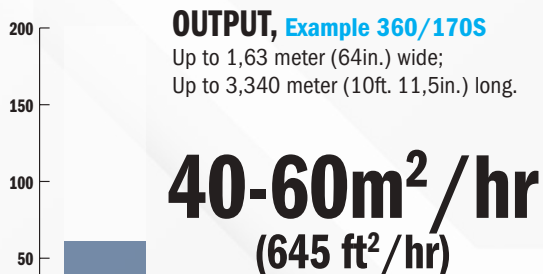

ROLLSROLLER® PREMIUM

Made to meet the needs of high volume industrial production



FEATURE CHART PREMIUM

GOOD CHOICE

ROLLSROLLER® Quality work station	✓
Original Cutting mat	✓
Roll holder on short side	✓
Roll holder on glide beam	✓
Casters-movability	✓
Solid welded steel chassis	✓
Side trays	✓
Powerful and ergonomic glide beam	✓
Customized sizes available	✓
ROLLSROLLER® warranty 5 years	✓
Shipped fully assembled (Plug & Play)	✓
Illuminated LED table- (dimnable)	✓
Big banner side feeding	✓
Electrical height adjustment	option
Additional glide beam with roller	option
Antistatic system	option
Air blow gun	option
EXC KeenCut EVO 3	option
VinylRemover	option
Additional roll holder short side	option
Heat assisted roller 40°C-60°C / 104°F-140°F	option
R-Drive (motorized glide beam)	option
Extended roller adjustment. Enables substrates up to 110 mm (4in.)	option
Oil free Compressor	option

ROLLSROLLER® INVENTOR EDITION

Arjan Janssen



FEATURE CHART INVENTOR EDITION

ROLLSROLLER® Quality work station	✓
Original Cutting mat	✓
Roll holder on short side	✓
Roll holder on glide beam	✓
Casters-movability	✓
Solid welded steel chassis	✓
Side trays	✓
Powerful and ergonomic glide beam	✓
Customized sizes available	✓
ROLLSROLLER® warranty 5 years	✓
Shipped fully assembled (Plug & Play)	✓
Illuminated LED table- (dimnable)	✓
Big banner side feeding	✓
Electrical height adjustment	✓
Additional glide beam with roller	✓
Antistatic system	✓
Air blow gun	✓
EXC KeenCut EVO 3	✓
VinylRemover	✓
Additional roll holder short side	✓
Heat assisted roller 40°C-60°C / 104°F-140°F	✓
Extended roller adjustment. Enables substrates up to 110 mm (4in.)	option
Oil free Compressor	option

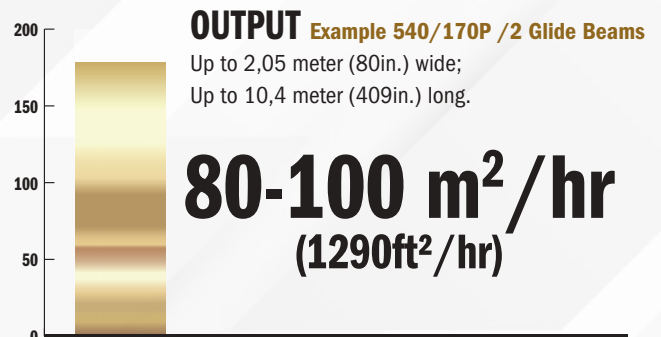
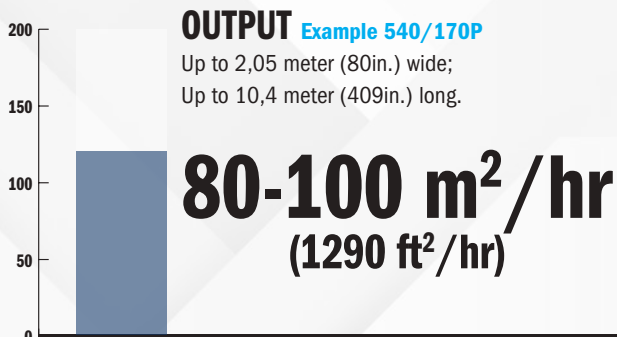

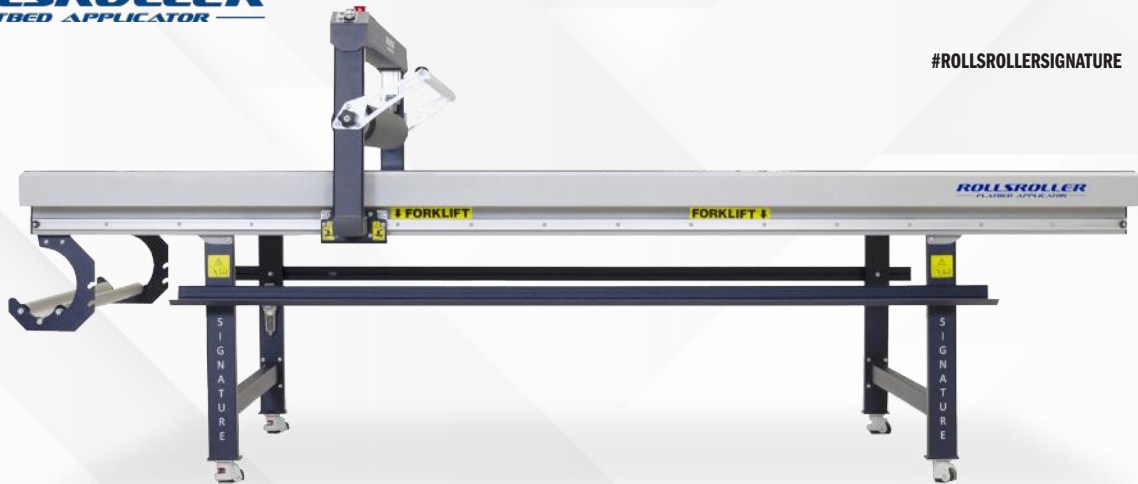

MODEL NAME	ROLLSROLLER® 120/100S	ROLLSROLLER® 300/147S	ROLLSROLLER® 300/170S	ROLLSROLLER® 360/147S
Part no.	122-001	122-002	122-003	122-004
Model type	Signature	Signature	Signature	Signature
Bed length	1 240 mm / 4ft. 0,8in.	3 040 mm / 9ft. 11,7in.	3 040 mm / 9ft. 11,7in.	3 640 mm / 11ft. 11,3in.
Bed width	1 000 mm / 3ft. 3,4in.	1 470 mm / 4ft. 9,9in.	1 700 mm / 5ft. 6,9in.	1 470 mm / 4ft. 9,9in.
Length of working area	940 mm / 3ft. 1in.	2 740 mm / 8ft. 11,9in.	2 740 mm / 8ft. 11in.	3 340 mm / 10ft. 11,5in.
Width of working area/roller width	930 mm / 3ft. 0,6in.	1 400 mm / 4ft. 7,1in.	1 630 mm / 5ft. 4,2in.	1 400 mm / 4ft. 7,1in.
Work height flatbed	875 mm / 2ft. 10,4in.	875 mm / 2ft. 10,4in.	875 mm / 2ft. 10,4in.	875 mm / 2ft. 10,4in.
Max. thickness of substrate	65 mm / 2,56in.	65 mm / 2,56in.	65 mm / 2,56in.	65 mm / 2,56in.
Bed surface	Tempered glass + Cutting mat	Tempered glass + Cutting mat	Tempered glass + Cutting mat	Tempered glass + Cutting mat
Optimized media holder on short side	yes	yes	yes	yes
Multi directional roll holder on glide beam	yes	yes	yes	yes
Casters movability	yes	yes	yes	yes
Side trays for tool storage	yes	yes	yes	yes
Powerful and ergonomic glide beam	yes	yes	yes	yes
Stop static kit (cord and magnet)	yes	yes	yes	yes

UPGRADE YOUR ROLLSROLLER®

PRODUCT NAME	PART NO.	PART NO.	PART NO.	PART NO.
Illuminated LED table- (dimnable)	111-001	111-002	111-003	111-004
Additional glide beam with roller	-	121-002	121-003	121-002
Air blow gun	126-055	126-055	126-055	126-055
EXC KeenCut EVO 3	71864	71864	71864	71864
VinylRemover (incl. bracket)	71869	71856	71856	71854
Additional roll holder short side	126-027	126-028	126-029	126-028
Roll cradle 1 300	126-056	126-056	126-056	126-056
Oil free Compressor	50213	50213	50213	50213

ROLLSROLLER® SIGNATURE

ROLLSROLLER® SIGNATURE if you have limited space. Delivered flat packed for access to almost any sign shop environment. Fast setup and low investment cost gives you access to the ROLLSROLLER® flatbed production method today.

THIS IS INCLUDED ROLLSROLLER® SIGNATURE Flatbed Applicator; Pneumatically controlled roller which is automatically adjusted for substrates up to 65 mm (2,56in); Flatbed worktable with a uniquely designed self-healing cutting mat; Roll holder on glide beam for pre-masking tape and laminate; Side trays.

CUSTOMIZED SIZES AVAILABLE Contact your dealer.

ROLLSROLLER® 360/170S	ROLLSROLLER® 420/147S	ROLLSROLLER® 420/170S
122-005	122-006	122-007
Signature	Signature	Signature
3 640 mm / 11ft. 11,3in.	4 240 mm / 13ft. 10,9in.	4 240 mm / 13ft. 10,9in.
1 700 mm / 5ft. 6,9in.	1 470 mm / 4ft. 9,9in.	1 700 mm / 5ft. 6,9in.
3 340 mm / 10ft. 11,5in.	3 940 mm / 12ft. 11,1in.	3 940 mm / 12ft. 11,1in.
1 630 mm / 5ft. 4,2in.	1 400 mm / 4ft. 7,1in.	1 630 mm / 5ft. 4,2in.
875 mm / 2ft. 10,4in.	875 mm / 2ft. 10,4in.	875 mm / 2ft. 10,4in.
65 mm / 2,56in.	65 mm / 2,56in.	65 mm / 2,56in.
Tempered glass+Cutting mat	Tempered glass+Cutting mat	Tempered glass+Cutting mat
yes	yes	yes
yes	yes	yes
yes	yes	yes
yes	yes	yes
yes	yes	yes
yes	yes	yes

PART NO.	PART NO.	PART NO.
111-005	111-006	111-007
121-003	121-002	121-003
126-055	126-055	126-055
71864	71864	71864
71854	71854	71854
126-029	126-028	126-029
126-056	126-056	126-056
50213	50213	50213

OUTPUT

Up to 1,63 meter (64in.) wide; Up to 4 meter (12ft 11,1in.) long.



40-60 m²/hr
(645 ft²/hr)

OPTIONS



Illuminated LED
Table (dimmable)



Additional Glide
beam with roller



Air blow gun



EXC KeenCut
EVO 3



Oil free
Compressor

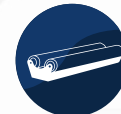

Roll cradle
1 300 mm



VinylRemover

WARRANTY

5 years limited warranty.



MODEL NAME	ROLLSROLLER® 300/170S Plus	ROLLSROLLER® 360/170S Plus	ROLLSROLLER® 360/212S Plus	ROLLSROLLER® 420/170S Plus	ROLLSROLLER® 420/212S Plus
Part no.	122-008	122-009	122-010	122-011	122-012
Model type	Signature Plus	Signature Plus	Signature Plus	Signature Plus	Signature Plus
Bed length	3040mm/ 9ft 11,7in	3640mm/ 11ft 11,3in	3640mm/ 11ft 11,3in	4240mm/ 13ft 10,9in	4240mm/ 13ft 10,9in
Bed width	1700mm/ 5ft 6,9in	1700mm/ 5ft 6,9in	2120mm/ 6ft 11,5in	1700mm/ 5ft 6,9in	2120mm/ 6ft 11,5in
Length of working area	2740mm/ 8ft 11,9in	3340mm/ 10ft 11,5in	3340mm/ 10ft 11,5in	3940mm/ 12ft 11,5in	3940mm/ 12ft 11,5in
Width of working area/roller width	1630mm/ 5ft 4,2in	1630mm/ 5ft 4,2in	2050mm/ 6ft 8,7in	1630mm/ 5ft 4,2in	2050mm/ 6ft 8,7in
Work height flatbed	800-1150mm/	800-1150mm/	800-1150mm/	800-1150mm/	800-1150mm/
Smart electrical height adjustment.	2ft 7,5in-3ft 9,3in	2ft 7,5in-3ft 9,3in	2ft 7,5in-3ft 9,3in	2ft 7,5in-3ft 9,3in	2ft 7,5in-3ft 9,3in
Max. thickness of substrate	65mm/ 2,56in	65mm/ 2,56in	65mm/ 2,56in	65mm/ 2,56in	65mm/ 2,56in
Bed surface	Glass + Cutting mat	Glass + Cutting mat	Glass + Cutting mat	Glass + Cutting mat	Glass + Cutting mat
Illuminated LED table- (dimnable)	yes	yes	yes	yes	yes
Integrated USB A + C charging station	yes	yes	yes	yes	yes
Optimized media holder on short side	yes	yes	yes	yes	yes
Multi directional roll holder on glide beam	yes	yes	yes	yes	yes
Casters-movability	yes	yes	yes	yes	yes
Side trays for tool storage	yes	yes	yes	yes	yes
Powerful and ergonomic glide beam	yes	yes	yes	yes	yes
Stop static kit (cord and magnet)	yes	yes	yes	yes	yes

UPGRADE YOUR ROLLSROLLER®

PRODUCT NAME	PART .NO	PART.NO	PART NO.	PART NO.	PART.NO
Additional glide beam with roller	121-003	121-003	121-004	121-003	121-004
Antistatic System	126-053	126-053	126-054	126-053	126-054
Air blow gun	126-055	126-055	126-055	126-055	126-055
EXC KeenCut EVO 3	71864	71864	71864	72520	71864
VinylRemover (incl. bracket)	71856	71856	71854	71854	71856
Additional roll holder on short side	126-029	126-029	126-030	126-029	126-030
Heat assisted roller 40°C-60°C	121-009	121-009	N/A	121-009	N/A
Extended roller adjustment. Enables substrates up to 110 mm (4in.)	On request	On request	On request	On request	On request
Roll cradle 1 300	126-056	126-056	126-056	126-056	126-056
Oil free Compressor	50213	50213	50213	50213	50213
R-Drive, motorized glide beam	On request	On request	On request	On request	On request

ROLLSROLLER® SIGNATURE PLUS

ROLLSROLLER® SIGNATURE PLUS is the perfect match for the modern sign shop. It has a wide range of options available.

ROLLSROLLER® 540/170S Plus	ROLLSROLLER® 540/212S Plus	ROLLSROLLER® 600/170S Plus	ROLLSROLLER® 600/212S Plus
122-013	122-014	122-015	122-016
Signature Plus	Signature Plus	Signature Plus	Signature Plus
5440mm/ 13ft 10,2in	5440mm/ 13ft 10,2in	6040mm/ 19ft 9,8in	6040mm/ 19ft 9,8in
1700mm/ 5ft 6,9in	2120mm/ 6ft 11,5in	1700mm/ 5ft 6,9in	2120mm/ 6ft 11,5in
5140mm/ 16ft 10,4in	5140mm/ 16ft 10,4in	5740mm/ 18ft 10in	5740mm/ 18ft 10in
1630mm/ 5ft 4,2in	2050mm/ 6ft 8,7in	1630mm/ 5ft 4,2in	2050mm/ 6ft 8,7in
800-1150mm/ 2ft 7,5in-3ft 9,3in	800-1150mm/ 2ft 7,5in-3ft 9,3in	800-1150mm/ 2ft 7,5in-3ft 9,3in	800-1150mm/ 2ft 7,5in-3ft 9,3in
65mm/ 2,56in	65mm/ 2,56in	65mm/ 2,56in	65mm/ 2,56in
Glass + Cutting mat	Glass + Cutting mat	Glass + Cutting mat	Glass + Cutting mat
yes	yes	yes	yes
yes	yes	yes	yes
yes	yes	yes	yes
yes	yes	yes	yes
yes	yes	yes	yes
yes	yes	yes	yes
yes	yes	yes	yes
yes	yes	yes	yes

PART.NO.	PART. NO	PART. NO	PART. NO
121-003	121-004	121-003	121-004
126-053	126-054	126-053	126-054
126-055	126-055	126-055	126-055
71864	72528	71864	71864
71854	71854	71854	71854
126-029	126-030	126-029	126-030
121-009	N/A	121-009	50118
On request	On request	On request	On request
126-056	126-056	126-056	126-056
50213	50213	50213	50213
On request	On request	On request	On request

THIS IS INCLUDED

ROLLSROLLER® Signature Plus Flatbed Applicator; Pneumatically controlled roller which is automatically adjusted for substrates up to 65 mm (2,56in)
LED Illuminated table top; Smart electrical height adjustable table with memory settings; Flatbed worktable with a uniquely designed self-healing cutting mat; Roll holder on glide beam for pre-masking tape and laminate; Roll holder on bed end for printed or cut film; Stop static kit (cord and magnet) to remove static electricity; USB A & C ports; Casters (lockable); Owner's manual.

CUSTOMIZED SIZES AVAILABLE Contact your dealer.

OUTPUT

Up to 2,05 meter (80in.) wide; Up to 5,74 meter (18ft 10in.) long.

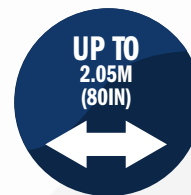

60-80 m²/hr
(861 ft²/hr)

OPTIONS



Additional Glide beam with roller



Antistatic system



Vinyl Remover



Motorized Glide beam



Heat assisted roller



Extended roller adjustment



Oil free Compressor



Air blow gun



EXC KeenCut EVO 3



Roll cradle 1 300 mm

WARRANTY

5 years limited warranty.
* On request contact your dealer



MODEL NAME	ROLLSROLLER® 400/170P	ROLLSROLLER® 400/220P	ROLLSROLLER® 540/170P	ROLLSROLLER® 540/220P	ROLLSROLLER® 605/170P	ROLLSROLLER® 800/170P
Part no.	10103	10320	10104	10105	10106	10518
Model type	Premium	Premium	Premium	Premium	Premium	Premium
Bed length	4 000 mm / 13ft. 2in.	4 000 mm / 13ft. 2in.	5 400 mm / 17ft. 9in.	5 400 mm / 17ft. 9in.	6 040 mm / 19ft. 10 in.	8 000 mm / 26ft. 3in.
Bed width	1 700 mm / 5ft. 7in.	2 200 mm / 7ft. 3in.	1 700 mm / 5ft. 7in.	2 200 mm / 7ft. 3in.	1 700 mm / 5ft. 7in.	1 700 mm / 5ft. 7in.
Length of working area	3 600 mm / 12ft.	3 600 mm / 12ft.	5 000 mm / 16ft. 5in.	5 000 mm / 16ft. 5in.	5 650 mm / 18ft. 6in.	7 600 mm / 25ft. 0in.
Width of working area/roller width	1 630 mm / 64in.	2 050 mm / 80in.	1 630 mm / 64in.	2 050 mm / 80in.	1 630 mm / 64in.	1 630 mm / 64in.
Work height flatbed	875 mm / 2ft. 10in.	875 mm / 2ft. 10in.	875 mm / 2ft. 10in.	875 mm / 2ft. 10in.	875 mm / 2ft. 10in.	875 mm / 2ft. 10in.
Max. thickness of substrate	60 mm / 2 2/5in.	60 mm / 2 2/5in.	60 mm / 2 2/5in.	60 mm / 2 2/5in.	60 mm / 2 2/5in.	60 mm / 2 2/5in.
Bed surface	Glass + Cutting mat	Glass + Cutting mat	Glass + Cutting mat	Glass + Cutting mat	Glass + Cutting mat	Glass + Cutting mat
Roll holder on short side	yes	yes	yes	yes	yes	yes
Roll holder on glide beam	yes	yes	yes	yes	yes	yes
Castors-movability	yes	yes	yes	yes	yes	yes
Powerful and ergonomic glide beam	yes	yes	yes	yes	yes	yes
Illuminated LED table- (dimnable)	yes	yes	yes	yes	yes	yes
Side trays	yes	yes	yes	yes	yes	yes
Stop static kit (cord and magnet)	yes	yes	yes	yes	yes	yes
R-Drive (motorized glide beam)	On request	On request	On request	On request	On request	On request

UPGRADE YOUR ROLLSSROLLER®

PRODUCT NAME	PART NO.	PART NO.	PART NO.	PART NO.	PART NO.	PART NO.
Electrical Height-adjustable table 750 - 1 100 mm 2ft. 3in. - 3ft. 7in.)	10375	11060	10360	10304	10383	11080
Additional glide beam with roller	10065	10066	10065	10066	10065	10065
Antistatic System	10424	10425	10424	10425	10424	10424
Air blow gun	70962	70962	70962	70962	70962	70962
EXC KeenCut EVO 3	71864	71864	71864	71864	71864	71864
VinylRemover (incl. bracket)	71854	71854	71854	71859	71854	71854
Additional roll holder short side	10052	10051	10052	10051	10052	10052
Heat assisted roller 40°C-60°C	50103		50103		50103	50103
Extended roller adjustment. Enables substrates up to 110 mm (4in.)	11092	On request	11092	On request	11092	11092
Roll cradle (2 pcs)	10098	10098	10098	10098	10098	10098
Oil free Compressor	50213		50213	50213	50213	50213

ROLLSROLLER® PREMIUM

ROLLSROLLER® PREMIUM is the **origin** of Flatbed Applicators and a **benchmark** for this technology. Premium is our best seller, made to meet the needs of high volume industrial production. Premium is equipped with side trays for rolls of banner media, which makes it ideal for flex-face sign applications.

THIS IS INCLUDED

ROLLSROLLER® Premium Flatbed Applicator; Pneumatically controlled user safe roller which is automatically adjusted for substrates up to 60 mm (2 2/5in); Light table; Flatbed worktable with a uniquely designed self-healing cutting mat; Roll holder on glide beam for pre-masking tape and laminate; Roll holder on bed end for printed or cut film; Side trays for rolls of banner media; Stop static kit (cord and magnet) to remove static electricity; Casters (lockable); Owner's manual.

CUSTOMIZED SIZES AVAILABLE Contact your dealer.

OUTPUT

Up to 2,05 meter (80in.) wide, Up to 10,4 meter (409in.) long.

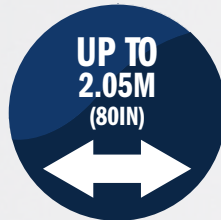

160-200 m²/hr
(1722-2153 ft²/hr)

OPTIONS



Electrical Height-adjustable table



Additional Glide beam with roller



Antistatic system



Air blow gun



EXCKeenCut EVO 3



VinylRemover



Additional roll holder short side



Heat assisted roller



Extended roller adjustment



SILTEK S/6 Oil free Compressor



Roll cradle 1 300 mm

ROLLER® 70P	ROLLSROLLER® 1080/170P 10107
	Premium
mm / 26ft. 3in.	10 800 mm / 35ft. 5in.
mm / 5ft. 7in.	1 700 mm / 5ft. 7in.
mm / 24ft. 11in.	10 400 mm / 34ft. 2in.
mm / 64in.	1 630 mm / 64in.
m / 2ft. 10in.	875 mm / 2ft. 10in.
/ 2 2/5in.	60 mm / 2 2/5in.
Cutting mat	Glass + Cutting mat
	yes
	yes
	yes
	yes
	yes
	yes
quest	On request

NO.	PART NO.
0	10549
5	10065
4	10424
2	70962
4	71864
4	71854
2	10052
3	50103
2	11092
3	10098
3	50213

WARRANTY

5 years limited warranty.





MODEL NAME	ROLLSROLLER® 540/170P HS IE	ROLLSROLLER® 605/170P HS IE
Part no.	11072	11044
Model type	Inventor Edition	Inventor Edition
Bed length	5 400 mm / 17ft. 9in.	6 040 mm / 19ft. 10 in.
Bed width	1 700 mm / 5ft. 7in.	1 700 mm / 5ft. 7in.
Length of working area	5000mm / 16ft 5in.	5650 mm / 18ft / 6in
Width of working area/roller width	1 630 mm / 64in.	1 630 mm / 64in.
Overall width incl. Glide beam	1 980 mm / 6ft. 6in.	1 980 mm / 6ft. 6in.
Overall height incl. Glide beam	1 500 mm / 4ft. 11in.	1 500 mm / 4ft. 11in.
Max. thickness of substrate	60 mm / 2 2/5in.	60 mm / 2 2/5in.
Work height flatbed	750 - 1 100 mm (2ft. 3in. - 3ft. 7in.)	750 - 1 100 mm (2ft. 3in. - 3ft. 7in.)
Bed surface	Glass + Cutting mat	Glass + Cutting mat
Power Supply (if illuminated)	230V/50Hz (10A) / 120V/60Hz (15A)	230V/50Hz (10A) / 120V/60Hz (15A)
Required air pressure	6 -8 bar / 87-116 psi	6 -8 bar / 87-116 psi
Warranty	5 years	5 years
Owner's Manual	DA, DE, ENG, ES, FR, SV	DA, DE, ENG, ES, FR, SV
Illuminated LED table- (dimnable)	yes, dimmable	yes, dimmable
Roll holder for Glide Beam	yes	yes
Roll holder for bed end	yes	yes
Casters-movability	yes (6)	yes (6)
Large Side trays for rolls of oversized banner material	yes	yes
Stop static kit, cord and magnet	yes	yes
Additional roll holder on short side	yes	yes
Electrical Height adjustment	yes, 750 - 1 100 mm/2ft. 3in. - 3ft. 7in.	yes, 750 - 1 100 mm/2ft. 3in. - 3ft. 7in.
Additional glide beam	Option	Option
Antistatic system (on one glide beam)	yes	yes
Air blow gun (on one glide beam)	yes	yes
EXC KeenCut EVO 3	yes	yes
VinylRemover	yes	yes
Extended roller adjustment. Enables substrates up to 110 mm (4in.)	option	option
Heat assisted roller 40°C-60°C	Option	Option
R-Drive (motorized glide beam)	On request	On request

* Length of working area, one glide beam 4600 mm / 15ft 1in.

** Length of working area, one glide beam 5250mm / 17ft 3in. ***The table on the picture is equipped with an additional glidebeam

**AVAILABLE
IN MORE
SIZES**

ROLLSROLLER® INVENTOR EDITION

**LET ROLLSROLLER®
INVENTOR EDITION TAKE
YOUR SIGN COMPANY TO
THE NEXT LEVEL.**

WANT TO GO FOR GOLD?

Let ROLLSROLLER® Inventor Edition take your sign company to the next level.

Wojciech Jankowski

PRODUCTION CAN START QUICKLY

- Fast ROI.
- Profitable.
- Easy to learn.

**FLATBED APPLICATOR DOES THE
JOB IN A THIRD OF THE TIME**

- Increased capacity
- Shorter delivery times
- More times for sales and customer care.

PERFECT RESULTS EVERY TIME

- Higher quality – no more bubbles and creases-Less wastage.
- Consistent high quality – every time.

ERGONOMIC WORK POSITION

- Better ergonomics.
- Less strain on the body
- Less sick leave.



OUTPUT

Up to 1,63 meter (64in) wide. Up to 6,04m (19ft 10in) long

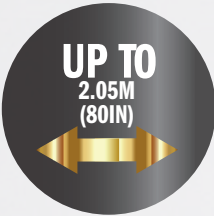

110-130 m²/hr
1184 - 1400ft²/hr

INCLUDED



Antistatic system



Height adjustable table



Additional roll holder



Air blow gun



EXC KeenCut EVO 3.



Vinyl Remover



Glide beam with heat roller 40°C-60°C



**WANT TO GO FOR GOLD?
UPGRADE YOUR
INVENTOR EDITION**

PRODUCT NAME	PART.NO
Oil free Compressor	50213

WARRANTY

5 years limited warranty.



MODEL NAME	ROLLSROLLER® 400/145T	ROLLSROLLER® 400/170T	ROLLSROLLER® 600/145T	ROLLSROLLER® 600/170T
Part no.	10355	10359	10354	10358
Model type	Traffic	Traffic	Traffic	Traffic
Bed length	4 000 mm / 13ft. 2in.	4 000mm / 13ft.2in.	6 000 mm / 19ft. 2in.	6 000 mm / 19ft. 2in.
Bed width	1 450 mm / 4ft. 9in.	1 700 mm / 5ft. 7in.	1 450 mm / 4ft. 9in.	1 700 mm / 5ft. 7in.
Length of working area	3 700 mm / 12ft. 2in.	3 700 mm / 12ft. 2in.	5 700 mm / 18ft. 8in.	5 700 mm / 18ft. 8in.
Width of working area/roller width	1 400 mm / 55in.	1 630 mm / 64in.	1 400 mm / 55in.	1 630 mm / 64in.
Work height flatbed	905 mm / 2ft. 12in.	905 mm / 2ft. 12in.	905 mm / 2ft. 12in.	905 mm / 2ft. 12in.
Max. thickness of substrate	60 mm / 2 2/5in.	60 mm / 2 2/5in.	60 mm / 2 2/5in.	60 mm / 2 2/5in.
Bed surface	Adjustable aluminum profiles	Adjustable aluminum profiles	Adjustable aluminum profiles	Adjustable aluminum profiles
Illuminated LED table- (dimnable)	Not available	Not available	Not available	Not available
Roll holder on glide beam	yes	yes	yes	yes
Roll holder on one short side	yes On request	yes	yes	yes
Stop static kit (cord and magnet)	yes	yes	yes	yes
R-Drive (motorized glide beam)	On request	On request	On request	On request

UPGRADE YOUR ROLLERTRAFFIC®

PRODUCT NAME	PART NO.	PART NO.	PART NO.	PART NO.
Height-adjustable table 750 - 1 100 mm (2ft. 3in. - 3ft. 7in.)	11058	18937	10553	18938
Additional glide beam with roller	71469	10446	71469	10446
Antistatic System	10423	10424	10423	10424
Additional roll holder on short side	11053	11060	11053	10060
EXC KeenCut EVO 3	71864	71864	71864	71864
VinylRemover	71856	71854	71856	71854
Extended roller adjustment. Enables substrates up to 110 mm (4in.)	On request	11092	On request	11092
Oil free Compressor	50213	50213	50213	50213



ROLLSROLLER® TRAFFIC

ROLLSROLLER® TRAFFIC is designed for road sign production with high volumes of guide signs. It has a special profile bed adjustable to fit almost any extruded guide sign panels. Bed surface consists of 40x40/1,57in aluminum profiles. When working with application tape and over-lay film ROLLSROLLER Entry, Regular or Premium is recommended to create a complete workflow.

THIS IS INCLUDED

ROLLSROLLER® Traffic Flatbed Applicator; Pneumatically controlled roller which is automatically adjusted for substrates up to 60 mm (2 2/5in); Adjustable aluminum profile bed (special design for mounting onto high volume of Guide sign panels); Roll holder on glide beam for pre-masking tape and laminate; Roll holder on bed end for printed or cut film; Stop static kit (cord and magnet) to dissipate static electricity; Casters (lockable); Machine feet; Owner's manual.

CUSTOMIZED SIZES AVAILABLE Contact your dealer.

OUTPUT

Up to 1,63 meter (64in.) wide; Up to 10,5 meter (413 in.) long.

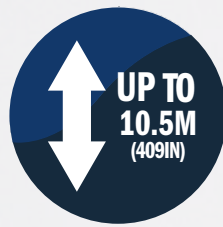

140-180 m²/h
(1507-1938 ft²/h)

- complete finished guide sign / operator

OPTIONS



Height-adjustable table



Additional glide beam with roller



Antistatic system



Additional roll holder short side



EXCKeenCut EVO 3



VinylRemover



Extended roller adjustment



SILTEK S/6 Oil free Compressor



Adjustable to fit different panels



ROLLSROLLER® Traffic bed surface

WARRANTY

5 years limited warranty.

ROLLSROLLER® 1080/145T

10353

Traffic

10 800 mm / 35ft. 5in.

1 450 mm / 4ft. 9in.

10 500 mm / 3ft. 5in.

1 400 mm / 55in.

905 mm / 2ft. 12in.

60 mm / 2 2/5in.

Adjustable aluminum profiles

Not available

yes

yes

yes

On request

PART NO.

18939

71469

10423

11053

71864

71856

On request

50213

ROLLSROLLER
— FLATBED APPLICATOR —

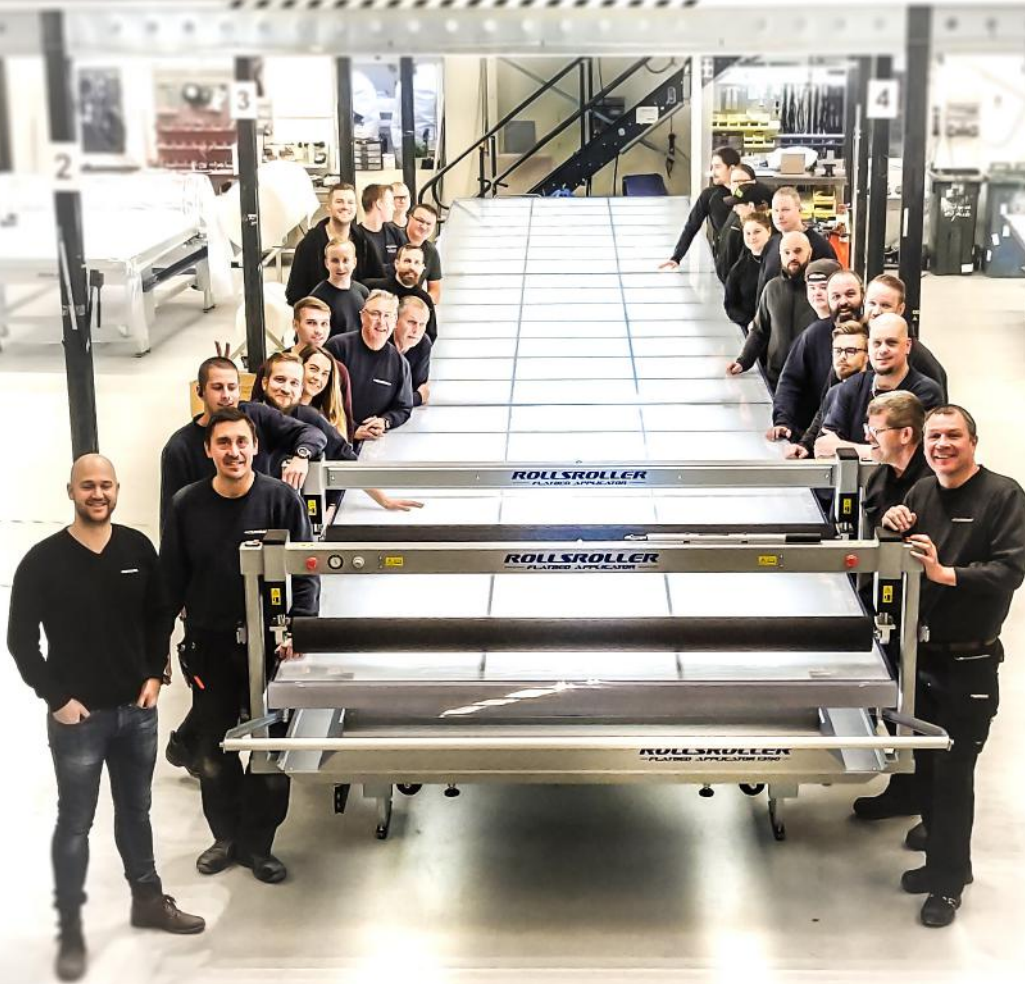

WORLD'S LONGEST
ROLLSROLLER®
1380/220 CUSTOMIZED

ROLLSROLLER®
ACTIVE WHEEL BED



ROLLSROLLER®
-NO LIMITS



 **COLORIZE**
YOUR ROLLSSROLLER



**ROLLSROLLER®
PASTA EXPRESS**



**ROLLSROLLER®
CUSTOMIZED
WIDTH**



ROLLSROLLER® CUSTOMIZED

THERE'S A ROLLROLLER® FOR EVERYONE

Can't find what you need in our standard range?

Don't worry, we can customize and create a Flatbed Applicator according to your specific requirements and needs! The unique ROLLROLLER® construction offers models that produces perfect quality up to 10,8m and 2,2m wide as standard.

But we can also customize a ROLLROLLER® that suits your needs. During our 20 years+ experience we have created many customized and uniquely designed ROLLROLLER® Flatbed Applicators. Our team of sales staff, engineers and technicians can support from idea to installation and training.

REASONS TO GET A CUSTOMIZED ROLLROLLER FLATBED APPLICATOR:

- Gives you the possibility to work with special sized materials (media, boards, aluminum/steel plate, acrylic etc..)
- Better overview of big signs when laid down on the flatbed
- Create more and bigger workstations in one machine
- Customize features, accessories and options to optimize your workflow

IMAGINATION IS THE ONLY OBSTACLE

So, let's think outside the box and let's put your need in front!

Remember, everything is possible! There's a ROLLROLLER for everyone!

Please contact us or your nearest Rollroller dealer for more info info@rollroller.se

OPTIONS



SILTEK S/6 Oil free Compressor



Extra Glide beam



Additional roll holder



Antistatic system



Roll cradle 1 300 mm



Cleaning system



Height-adjustable table



Air blow gun



EXCKeenCut EVO 3



VinylRemover



Heat assisted roller



Illuminated LED table- (dimnable),



Traffic profile bed.

WARRANTY

5 years limited warranty.

5 REASONS TO CHOOSE ROLLSROLLER®

1. THE ROLLSROLLER® FLATBED APPLICATOR WAS INVENTED BY A SIGN MAKER

WE INVENTED THE FLATBED APPLICATOR TECHNOLOGY because as sign makers, we needed a more efficient work process. The ROLLSROLLER® Flatbed Applicator was devised from a user perspective: it facilitates production and solves real-life problems. Thanks to a variety of accessories and modifications, you can rest assured that it will satisfy your specific requirements. Because we use the ROLLSROLLER® in our own daily production, we have a unique understanding of industry challenges and needs – and the ROLLSROLLER® is the living proof.

2. WE SET THE STANDARD. THE ROLLSROLLER® HAS SET THE QUALITY STANDARD FOR FLATBED APPLICATORS

– and that didn't happen by accident. Since we invented the method and technology, it has undergone a natural development based on our customers' requirements and specific problems as well as our own 30-year experience as sign makers. The ROLLSROLLER® Flatbed Applicator is manufactured from start to finish at our factory in Karlstad, Sweden – from the welding of the steel chassis to final assembly and testing. Keeping the whole production process in-house gives us full control over quality and greater flexibility with regard to design changes, customisation and product improvement.

WHY THE ROLLSROLLER® TRAVERSE/GANTRY MAKE YOUR FLATBED APPLICATOR STAND OUT FROM OTHERS!



ROLLSROLLER®
— FLATBED APPLICATOR —

WE ARE SIGN MAKERS
AND BUILD MACHINES
WE LIKE TO USE OUR-
SELVES.

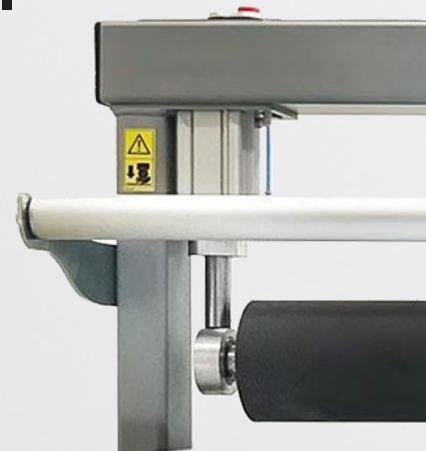

4. PRODUCT DEVELOPMENT SINCE 1995

ROLLSROLLER® FLATBED APPLICATOR IS A FLEXIBLE and reliable tool that can be used for a large variety of jobs every day. This is because we have continuously developed the materials and components over more than 30 years. For example, there's a good reason why the chassis and beam are made completely out of steel: steel does not deform over time, even if the underlying surface is uneven. The roller has reached its fifth generation, and is designed to have optimal surface properties for the material being used. Based on our long experience and in close dialogue with customers, we have added new functions such as a height-adjustable table, cutting devices and our Contact Cleaning System.

5. THERE'S A ROLLER® FOR EVERYONE

THE ROLLER® COMES IN A wide range of models specially designed to give you multiple options. We want everybody to find their ideal ROLLER®. We offer a wide selection of flatbed applicators: sizes and prices and many add-on options. It all depends on your needs. What size signs do you work with? What media widths do you use? What do you need to make your work even easier? What are your future needs? In addition, we can customise the ROLLER® to suit your needs. We have created many unique machines in consultation with our customers. There's a ROLLER® for everyone – and if your model doesn't exist, we can create it.

3. THE ROLLER® REVOLUTIONISES YOUR WORK

THE ROLLER® WILL SIGNIFICANTLY RAISE YOUR PRODUCTIVITY allowing you to take many more jobs and offer shorter delivery times. In addition, you will have more time left for other things such as organising and scheduling your staff's work. In fact, many customers see it as a competitive disadvantage not to use ROLLER® Flatbed Applicator, since it provides such an enormous head start on companies who still use traditional working methods.

1. THE TRAVERSE/GANTRY MAKES YOU WORK ERGONOMICALLY. When leaning over the table surface with sensitive self-adhesive material you can hold on to the ROLLER® glide beam. **2. THE OPERATOR CAN WORK FROM ALL FOUR SIDES** The operator is in total control and also saves time. **3. SIZE OF THE TABLE DOES NOT MATTER.** The ROLLER® glide beam produces perfect quality up to 10,8m and 2,2m wide as standard. **4. MORE POWER USING LESS MUSCLES.** The glide beam moves very smooth and easy. **5. LARGER WORK AREA ON THE MACHINE.** Greater opportunity to utilize the table size. **6. THE TRAVERSE GIVES YOU POSSIBILITY TO ADD ACCESSORIES** A great place for anti-static equipment and magnetic accessories such as Long reach cutter, scissors, knives and other options. **7. THE TRAVERSE MAKES THE MACHINE STABLE AS A ROCK** Solid and proven steel construction. Over 11 000 units installed globally. **8. DOUBLE THE EFFECTIVITY!** Add an extra ROLLER® glide beam – **9. THE ROLLER® GLIDE BEAM ALLOWS OPTION TO INCREASE HEIGHT OF THE ROLLER.** The gap between the roller and the table top accommodates different substrates up to 110mm /4,5 in.



ROLLSROLLER FLATBED APPLICATOR- TECHNICAL VALUES

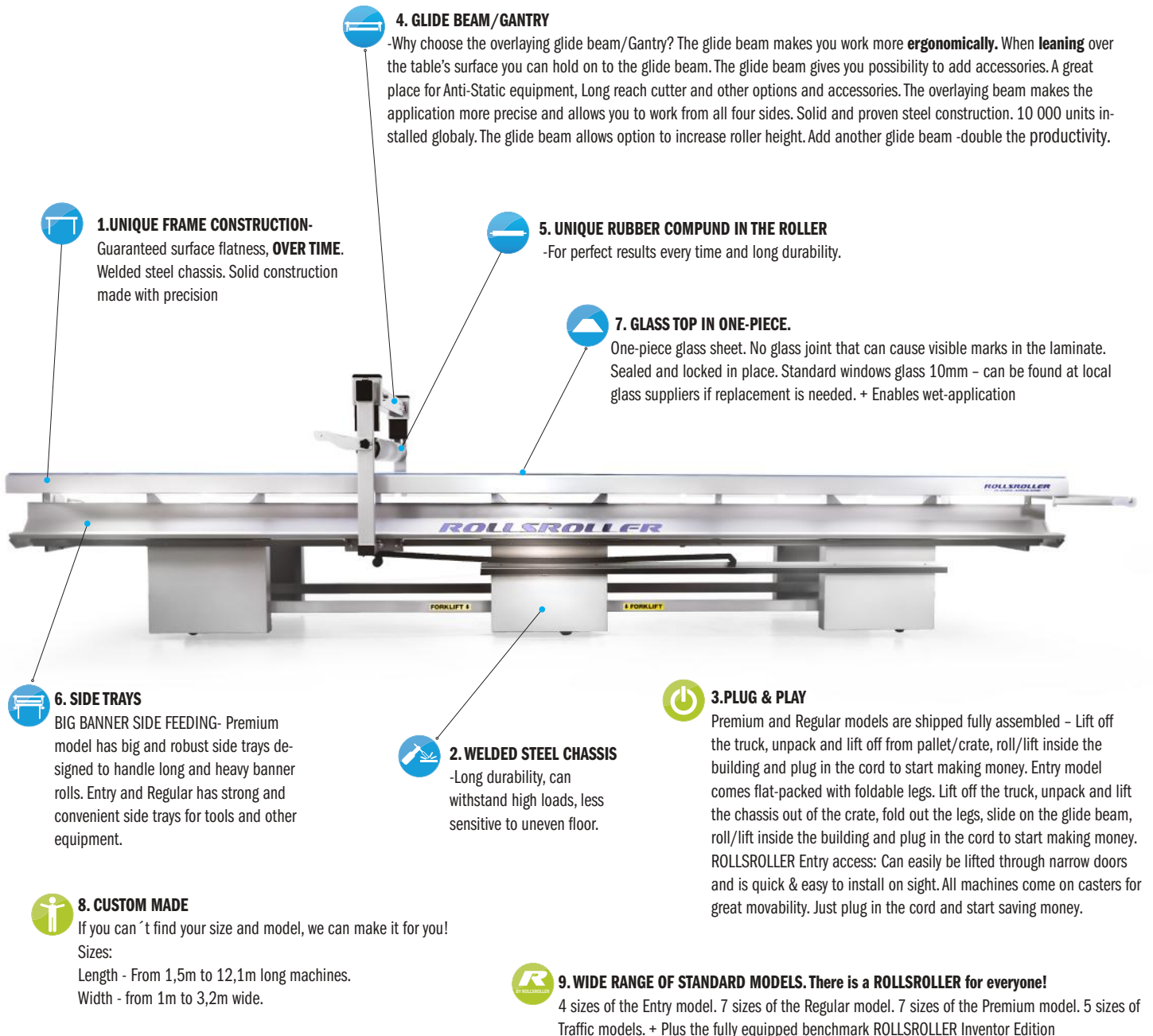

1. UNIQUE FRAME CONSTRUCTION-
Guaranteed surface flatness, **OVER TIME.**
Welded steel chassis. Solid construction made with precision

4. GLIDE BEAM/GANTRY

-Why choose the overlaying glide beam/Gantry? The glide beam makes you work more **ergonomically**. When **leaning** over the table's surface you can hold on to the glide beam. The glide beam gives you possibility to add accessories. A great place for Anti-Static equipment, Long reach cutter and other options and accessories. The overlaying beam makes the application more precise and allows you to work from all four sides. Solid and proven steel construction. 10 000 units installed globally. The glide beam allows option to increase roller height. Add another glide beam -double the productivity.

5. UNIQUE RUBBER COMPUND IN THE ROLLER
-For perfect results every time and long durability.

7. GLASS TOP IN ONE-PIECE.

One-piece glass sheet. No glass joint that can cause visible marks in the laminate. Sealed and locked in place. Standard windows glass 10mm - can be found at local glass suppliers if replacement is needed. + Enables wet-application

6. SIDE TRAYS

BIG BANNER SIDE FEEDING- Premium model has big and robust side trays designed to handle long and heavy banner rolls. Entry and Regular has strong and convenient side trays for tools and other equipment.

2. WELDED STEEL CHASSIS

-Long durability, can withstand high loads, less sensitive to uneven floor.

3. PLUG & PLAY

Premium and Regular models are shipped fully assembled - Lift off the truck, unpack and lift off from pallet/crate, roll/lift inside the building and plug in the cord to start making money. Entry model comes flat-packed with foldable legs. Lift off the truck, unpack and lift the chassis out of the crate, fold out the legs, slide on the glide beam, roll/lift inside the building and plug in the cord to start making money. ROLLSSROLLER Entry access: Can easily be lifted through narrow doors and is quick & easy to install on sight. All machines come on casters for great movability. Just plug in the cord and start saving money.

8. CUSTOM MADE

If you can't find your size and model, we can make it for you!

Sizes:

Length - From 1,5m to 12,1m long machines.

Width - from 1m to 3,2m wide.



9. WIDE RANGE OF STANDARD MODELS. There is a ROLLSSROLLER for everyone!

4 sizes of the Entry model. 7 sizes of the Regular model. 7 sizes of the Premium model. 5 sizes of Traffic models. + Plus the fully equipped benchmark ROLLSSROLLER Inventor Edition

Signs be
ROLLS
FLATBED



ROLLSROLLER® ACADEMY



WELCOME TO ROLLSROLLER® ACADEMY. Based on our long experience of sign making and our invention Flatbed Applicators, we guide you to a more simple and more efficient way of manufacturing signs.

HOW TO APPLY TRANSFER TAPE AND APPLICATION TAPE

Transfer tape applicator simplifies pre-masking. ROLLSROLLER® makes it simple to apply transfer tape and application tape by only one person.

Read more and view video:

www.rollssroller.com/our-products/how-to/apply-application-tape/



HOW TO MAKE FLEX FACE SIGNS

ROLLSROLLER® Flatbed Applicator allows producing a flex-face sign easily with only one person. You don't need any application fluids, forget about getting everything all wet. No more drying time, your sign face is ready to install in no time. One person can do over-sized sign faces even when you need to overlap the cutting film. Read more and view video:

www.rollssroller.com/our-products/how-to/make-flex-face-signs/



HOW TO MOUNT LARGE FORMAT DIGITAL PRINT FAST

Learn how to mount digital prints fast. Mount large format digital print with up to 80% time savings and with minimum waste. Read more and view video: www.rollssroller.com/our-products/how-to/mount-digital-print/



HOW TO MAKE TRAFFIC SIGNS

Over the past decade several hundred road sign manufacturers have increased their productivity more than 100% by upgrading their production line to ROLLSROLLER® flatbed applicator technology. Read more and view video:

www.rollssroller.com/our-products/how-to/make-traffic-signs/



HOW TO MOUNT LARGE FORMAT DIGITAL PRINT FAST

Learn how to mount digital prints fast. Mount large format digital print with up to 80% time savings and with minimum waste. Read more and view video:

www.rollssroller.com/our-products/how-to/mount-digital-prints/



MAKING ROAD SIGNS THE SCANDINAVIAN WAY

Traffic signs or road signs are signs erected at the side of or above roads to give instructions or provide information to road users. Manufacturing of road sign has changed a great deal over the past decade. Today, advanced technology is enabling increased productivity, less wastage and of course, better results. Read more:

www.rollssroller.com/our-products/how-to/make-road-signs/



VISIT ROLLSROLLER ON YOUTUBE



SELF HEALING CUTTING MATS

A UNIQUE ROLLSROLLER® SELF-HEALING CUTTING MAT

has been developed through many years according to our specifications and high demand for quality. It is designed for large scale cutting, to protect your work bench and your blades. The ROLLSROLLER® cutting mat is included in your new ROLLSROLLER® but can be used for all flatbed applicator brands and/or work benches.

A worn cutting mat or a mat of poor quality may affect lamination quality. Compared to other cutting mats on the market, the ROLLSROLLER® cutting mat guarantees that the substrate is even throughout the entire work table which is very important when using a Flatbed Applicator. Custom made original cutting mats can be used on any worktable and is available in any size.

THE ROLLSROLLER® ORIGINAL CUTTING MATS ARE TOTALLY FREE FROM PHTHALATE PLASTICIZERS.

PHTHALATES plasticizers are used to make the plastic soft and flexible and can, according to several studies, have a negative impact on human health and environment. To protect human health and environment ROLLSROLLER® have decided to only sell PHTHALATE-FREE cutting mats.

Our label "PHTHALATE-FREE" will give you the assurance that our soft vinyl is the best choice for human health and environment protection.



FEATURES

- Delivered oversized (when installed, the mat should be cut to exact worktable size)
- Maximum length 22 meter (72ft.)
- Custom made cutting mat is available in any size. Price is calculated based on length.
- Don't forget to replace your old cutting mat. A worn cutting mat may affect lamination quality.
- Our cutting mats can also be used to protect your regular cutting table.
- NON-PHTHALATE

MODEL NAME	DESCRIPTION / DIMENSIONS	PART NO.
ROLLSROLLER® Original Cutting mat 150/100	1 500 x 1 000 mm / 4ft. 11in. x 3ft. 3in.	70708
ROLLSROLLER® Original Cutting mat 280/145	2 800 x 1 450 mm / 9ft. 2 in. x 4ft. 9in.	10071
ROLLSROLLER® Original Cutting mat 340/145	3 400 x 1 450 mm / 11ft 2in x 4ft. 9in.	10237
ROLLSROLLER® Original Cutting mat 340/170	3 400 x 1 700 mm / 11ft 2in x 5ft. 7in.	10301
ROLLSROLLER® Original Cutting mat 340/220	3 400 X 2 200 mm / 11ft. 2in. X 7ft. 3in.	11086
ROLLSROLLER® Original Cutting mat 400/145	4 000 x 1 450 mm / 13ft. 2in. x 4ft 9in.	10345
ROLLSROLLER® Original Cutting mat 400/150	4 000 x 1 500 mm / 13ft. 2in. x 4ft. 1in.	10070
ROLLSROLLER® Original Cutting mat 400/170	4 000 x 1 700 mm / 13ft. 2in. x 5ft. 7in.	10220
ROLLSROLLER® Original Cutting mat 400/220	4 000 x 2 200 mm / 13ft. 2in. X 7ft. 3in.	10374
ROLLSROLLER® Original Cutting mat 540/170	5 400 x 1 700 mm / 17ft. 9in. x 5ft. 7in.	10073
ROLLSROLLER® Original Cutting mat 540/220	5 400 x 2 200 mm / 17ft. 9in. x 7ft. 3in	10072
ROLLSROLLER® Original Cutting mat 605/170	6 050 x 1 700 mm / 19ft. 10in. x 5ft. 7in.	10075
ROLLSROLLER® Original Cutting mat 800/170	8 000 x 1 700 mm / 26ft. 3in. X 5ft. 7in.	10150
ROLLSROLLER® Original Cutting mat 1080/170	10 800 x 1 700 mm / 35ft. 5in. x 5ft. 7in.	10076
ROLLSROLLER® Original Cutting mat 120/100	1 240 x 1 000 mm / 4ft. 0,8in x 3ft. 3,4in.	116-001
ROLLSROLLER® Original Cutting mat 300/147	3 040 x 1 470 mm / 9ft. 11,7in. x 4ft. 10in.	116-002
ROLLSROLLER® Original Cutting mat 300/170	3 040 x 1 700 mm / 9ft. 11,7in. x 5ft. 7in.	116-003
ROLLSROLLER® Original Cutting mat 360/147	3 640 x 1 470 mm / 11ft. 11in x 4ft. 10in.	116-004
ROLLSROLLER® Original Cutting mat 360/170	3 640 x 1 700 mm / 11ft. 11in x 5ft. 7in.	116-005
ROLLSROLLER® Original Cutting mat 420/147	4 240 x 1 470 mm / 13ft. 11in x 4ft. 10in.	116-006
ROLLSROLLER® Original Cutting mat 420/170	4 240 x 1 700 mm / 13ft. 11in. x 5ft. 7in.	116-007
ROLLSROLLER® Original Cutting mat 420/212	4 240 x 2 212 mm / 13ft. 11in. x 6ft. 12in	116-008

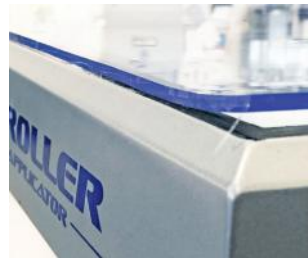

CUSTOM MADE ORIGINAL CUTTING MATS can be used on any worktable and is available in any size. Contact your dealer for more information.

CUSTOM MADE CUTTING MAT	MAXIMUM WIDTH	MAXIMUM LENGTH	PART NO.
Cutting mat 150	1 500 mm / 4ft. 1in.	22 meter / 72ft.	71340
Cutting mat 173	1 730 mm / 5ft. 8in.	22 meter / 72ft.	71341
Cutting mat 220	2 200 mm / 7ft. 3in.	22 meter / 72ft.	71342

ROLLSROLLER® CUTTING MATS CAN BE USED FOR FOLLOWING BRANDS OF FLATBET APPLICATORS: ROLL-ROLLER ROLL-X - CWT - ROLLOVER - BUBBLE-FREE

ROLLSROLLER® ORIGINAL CUTTING MAT 280/145

ROLLSROLLER® 280/145 Entry
ROLLSROLLER® 280/145 Regular
ROLLSROLLER® 280/145 Basic
CWT 1418 Advantage,
Bubblefree 280/150 Pro.

ROLLSROLLER® ORIGINAL CUTTING MAT 340/145

ROLLSROLLER® 340/145 Entry,
ROLLSROLLER® 340/145 Regular
ROLLSROLLER® 340/145 Basic
Bubblefree 340/150 Pro.

ROLLSROLLER® ORIGINAL CUTTING MAT 340/170

ROLLSROLLER® 340/170 Entry,
ROLLSROLLER® 340/170 Regular
ROLLSROLLER® 340/170 Basic
Roll-X 327/175 Professional
Roll-X 327/175 Advantage
Roll-X 327/175 GO
CWT 1630 Regular
CWT 1630 Premium,
Rollover 300/170 Classic
Rollover 336/155 Flexi
Bubblefree 340/170 Pro

ROLLSROLLER® ORIGINAL CUTTING MAT 400/170

ROLLSROLLER® 400/170 Regular & Basic
ROLLSROLLER® 400/170 Premium
ROLL-X 400/175 Professional
ROLL-X 400/175 Advantage
ROLL-X 400/175 GO
CWT 1736 Platinum
CWT 1640 Premium
CWT 1640 Regular
Rollover 400/170 Classic
Bubblefree 400/170 Pro.

ROLLSROLLER® ORIGINAL CUTTING MAT 540/170

ROLLSROLLER® 540/170 Premium
Bubblefree 540/170 Pro.

ROLLSROLLER® ORIGINAL CUTTING MAT 540/220

ROLLSROLLER® 540/170 Premium
Bubblefree 540/220 Pr.

ROLLSROLLER® ORIGINAL CUTTING MAT 605/170

ROLLSROLLER® 605/170 Premium
Rollover 600/170 Classic

MAKE PERFECTLY STRAIGHT CUTS

GREAT CUTTING EQUIPMENT FOR ROLLSROLLER® FLATBED APPLICATOR To improve and modify your ROLLSROLLER Flatbed Applicator. Make your job even easier.



ROLLSROLLER® SCISSORS
MAKE YOUR JOB EVEN EASIER.

MODEL NAME	PART NO.
ROLLSROLLER® scissors	10078

EXC SAFETYRULER

A SAFETY RULER WITH ANTI-SLIDING PAD UNDERNEATH

and protection-bar for your hand. The ruler is made of low weight Aluminum and is equipped with a measuring tape/graduated scale (mm or ft.in.). The EXC SafetyRuler has a built-in slide-bar which allows you to upgrade with a Cutting head which makes it easier to cut perfectly straight. The Cutting head can be slid from one end of the Ruler to the other without falling out of the rails. This assures you an easy cut even through thicker panels. Cutting head EXC SafetyRuler, KNIFE & wheel version.

Get the most comfort and safety while cutting with less effort. The Cutting head can fast and easy be mounted and detached depending on the need. The design of the cutting head and SafetyRuler slide-bar assures you an easy and straight cut even through thicker panels (we recommend to not cut on aluminum-coated-panels)

CUTTING HEAD EXC SAFETYRULER,

KNIFE VERSION Easy to install and use together with the EXC SafetyRuler, Knife cuts exactly along the edge of the SafetyRuler. High safety when cutting.

CUTTING HEAD EXC SAFETYRULER,

WHEEL Easy to install and use together with the EXC SafetyRuler. Knife cuts exactly along the edge of the SafetyRuler. High safety when cutting. Recommended for cutting textiles and fabrics.



MODEL NAME	DESCRIPTION / DIMENSIONS	PART NO.
EXC SafetyRuler 1,5m	1,5m / 4ft. 11,05in.	72457
EXC SafetyRuler 2.5m	2.5m/8ft 2.42in	72458
EXC SafetyRuler 3,5m	3.5m/11ft 5.79in	72459

MODEL NAME	DESCRIPTION / DIMENSIONS	PART NO.
Cutting head EXC SafetyRuler	Knife	72460
Cutting head EXC SafetyRuler	Wheel	72461

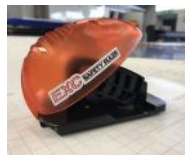
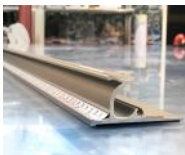

ROLLSROLLER® LONG REACH CUTTER

ERGONOMIC TO USE – reach over the worktable without leaning over the table, which normally can cause strain to your back and shoulders. Equipped with practical magnets on the handle. Easy to attach to the ROLLSROLLER® steel-frame. Cutting blades in titan can be rotated up to 4 times. The titan blade cuts through many materials: banners, textile, vinyl and paper. Extra titan blades 10pcs are included.



MODEL NAME	DIMENSIONS	PART NO.
ROLLSROLLER® Long reach cutter 60	600 mm / 1ft. 11in.	10493
ROLLSROLLER® Long reach cutter 90	900 mm / 1ft. 11in.	10494

MODEL NAME	DESCRIPTION	PART NO.
ROLLSROLLER® Long reach cutter blade	Titan Blade 10pcs	10402

EXC KEENCUT EVO 3

THE ULTIMATE MANUAL CUTTER FOR WIDE FORMAT AND GRAPHIC MATERIALS. Created for the busy print shop, the Evolution-E3 reduces errors and wastage to save you time and money. Upgrade your Flatbed Applicator Speeds up production- Double-tool head: single-handed cutting in both directions. Built for efficiency- Integral, linked lift & hold allows one operator to lift the complete cutter from either end for easy loading and positioning of media.

PERFECT FOR CUTTING

Semi-rigid materials. Cardboard PVC foam board. foam-centred board. corrugated plastic up to 13 mm .Mountboard and conservation board up to 3.5mm. Flexible polycarbonate up to 3mm. Flexible materials Tough materials, banners, pop-ups, magnetic sheets. Film and self-adhesive vinyls. Delicate materials: tissue paper, fabrics, wallpaper & textiles. Rigid material Cast acrylic or Plexiglas up to 3mm.

FEATURES

- The most accurate cutter on the market.
- For high volume production.
- Speeds up production.
- Saves workshop space.
- Versatile two-way cutting.
- Keeps wastage to a minimum.
- Safety by design.
- Minimal set-up.
- Simple and instinctive operation.
- Precision-engineered for immediate 'out of the box' accuracy.
- Guaranteed for 5 years

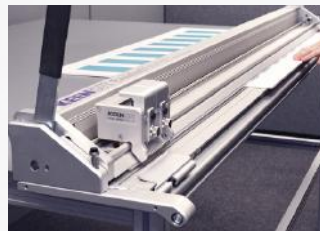

MODEL NAME	DESCRIPTION / DIMENSIONS	PART NO.
EXC KeenCut EVO 3	1 600 mm / 5ft 3 in.	71864 (incl. bracket)

MODEL NAME	DESCRIPTION / DIMENSIONS	PART NO.
Bracket for KeenCut EV03 170P	For attachment to ROLLSROLLER	10537 (buy bracket separately)
Bracket for KeenCut EV03 170R	For attachment to ROLLSROLLER	10538 (buy bracket separately)
Bracket for KeenCut EV03 170E	For attachment to ROLLSROLLER	10555 (buy bracket separately)

ACCESSORIES TO IMPROVE AND MODIFY YOUR ROLLSROLLER®

Great accessories to improve and modify your ROLLSROLLER® Flatbed Applicator. To make your job even easier. Choose between many original accessories to improve your daily work.

ROLL CRADLE

ROLL CRADLE IS A MEDIA HOLDER

with rollers that facilitate the winding of roll media. Its placed in the side trays or directly on the flatbed.



Roll cradle with media roll

MODEL NAME	DESCRIPTION / DIMENSIONS	PART NO.
ROLLSROLLER® Roll Cradle 400	Set of 2pcs. Width: 400 mm / 1ft 3in.	10098
ROLLSROLLER® Roll Cradle 1300	1 300 mm / 4ft. 3in	40018



MODEL NAME	DESCRIPTION / DIMENSIONS	PART NO.
Optimized media holder 100S	Fits all models 100S	126-027
Optimized media holder 147S	Fits all models 147S	126-028
Optimized media holder 170S	Fits all models 170S	126-029
Optimized media holder 212S	Fits all models 212S	126-030
Roll Holder 150P	Fits all models 150P	10243
Roll Holder 170P	Fits all models 170P	10052
Roll Holder 220P	Fits all models 220P	10051

ROLL HOLDER SHORT SIDE

ADDITIONAL ROLL HOLDER SHORT SIDE used for holding a roll of print or other roll-media. The roll holder is standard equipment to the ROLLSROLLER® and it's attached to one of the short sides. An extra roll holder can be mounted to the opposite side.

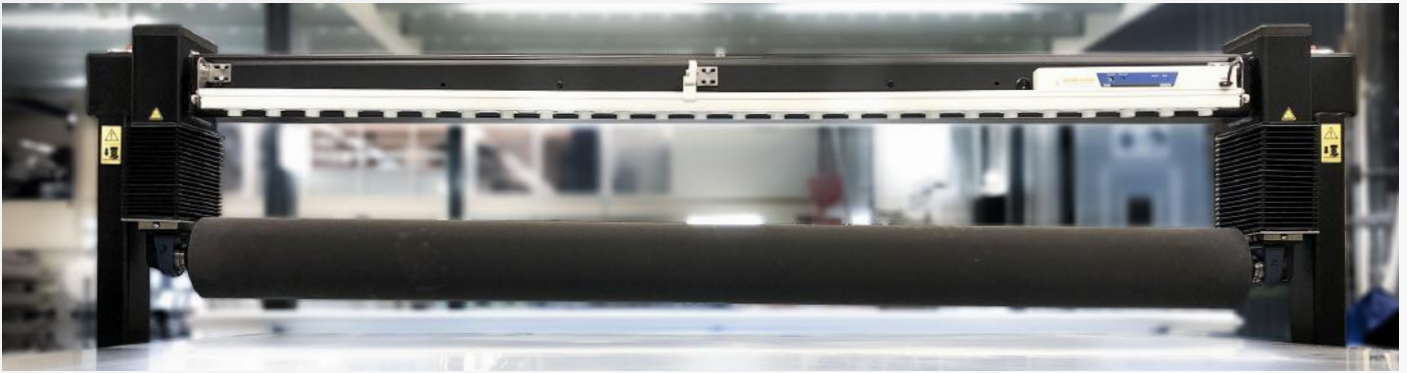

ANTISTATIC SYSTEM

IS A DEVICE THAT NEUTRALIZES STATIC ELECTRICITY from the substrate and the material being applied. Antistatic system is an active device that removes static electricity from the actual work area – it is mounted onto the glide beam to follow the glide beam and its pressure roller over the flatbed. Choose between three modes of emits for efficient elimination of static electricity: a combination of + and - charged ions, + or - charged ions.

- Prevents material sticking together
- Three emit modes
- Nozzles are replaceable

KEY FEATURES

- Active ioniser - neutralizes static electricity in the work area
- Follows the glide beam and covers the entire flatbed
- Prevents dust in the work area
- Retro fit any model
- Three models



MODEL NAME	DESCRIPTION/DIMENSIONS	PART NO.
Antistatic system 80	800 mm / 2ft. 3in	10525
Antistatic system 130	1 300 mm / 4ft. 3in	10423
Antistatic system 160	1 600 mm / 5ft 3in	10424
Antistatic system 190	1 900 mm / 6ft 2in	10425



AIR BLOW GUN

AIR BLOW GUN CAN BE CONNECTED TO THE BEAM.

Facilitates cleaning. Easily takes blows cuttings of metal from the surface.

Simple installation, can be retrofitted. Connects to the Glide beam's air system. No need of an extra compressor.

MODEL NAME	DESCRIPTION	PART NO.
Air Blow Gun	Connect to the beam	70962

UPGRADE YOUR ROLLSROLLER®

IT'S EASY TO UPGRADE YOUR ROLLSROLLER®



ADDITIONAL GLIDE BEAM

CREATES A SECOND WORKSTATION. DOUBLE PRODUCTIVITY ON THE SAME FLOOR SPACE. Second Glide beam can be upgraded with more or new accessories like Heat roller, Antistatic system or Cleaning system.

MODEL NAME	FITS MODEL	PART NO.
Additional Glide beam 147S	300/147S, 360/147S, 420/147S	121-002
Additional Glide beam 170S	300/170S, 360/170S, 420/170S, 540/170S, 600/170S	121-003
Additional Glide beam 212S	360/212S, 420/212S, 540/212S, 600/212S	121-004
Additional Glide beam 170P	400/170P, 540/170P, 605/170P, 1080/170P	10065
Additional Glide beam 220P	540/220P, 605/220P	10066
Additional Glide beam 145T	400/145T	71469
Additional Glide beam 170T	400/170T	10446



HEAT ROLLER

HEAT ROLLER COMBINES THE ADVANTAGES OF FLATBED APPLICATION and our technology for a thermal roll with controlled consistent temperature around the roll mantle. The heated roller reduces the appearance of microbubbles (silvering) in the laminate and improves the adhesive activation, which mean faster delivery to customer. The roller temperature can easily be adjusted as needed; 40-60°C. The working temperature is shown on a display on the glide beam

- ROLLSROLLER® WILL, WITH THE HEAT ROLLER, BECOME AN EVEN MORE VERSATILE TOOL.

MODEL NAME	DESCRIPTION/DIMENSIONS	PART NO.
Heat assisted roller, 170 Signature Plus	40°C-60°C/104°F-140°F	121-009
Heat assisted roller, 170 Premium	40°C-60°C/104°F-140°F	50103

*Factory assembled, for retro fitting add cost for an additional glide beam

EXTENDED ROLLER ADJUSTMENT

THE STANDARD HEIGHT BETWEEN THE ROLLER AND THE BED IS 60 MM (2.36 IN.),

The extended roller adjustment allows to increase the standard gap of 60 mm (2,36 in) to 110mm (4.33 in) and therefore capable of handling even higher/thicker materials.



On customer request we can also create an individual solution with which even higher / thicker materials can be processed.



MODEL NAME	DESCRIPTION/DIMENSIONS	PART NO.
Extended roller adjustment 150P	Enables substrates to 110 mm (4in.)	On request
Extended roller adjustment 170P	Enables substrates to 110 mm (4in.)	11092
Extended roller adjustment 220P	Enables substrates to 110 mm (4in.)	On request

CUSTOMIZED JIG

FOR TRAFFIC SIGN MANUFACTURING.

The jig has a start and stop space next to the sign to create a support for the pressurized roller. The Jig is oversized to create a support for the pressurized roller when moving on and of the sign face.

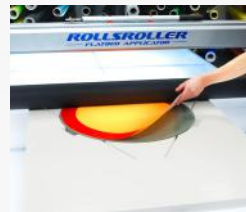
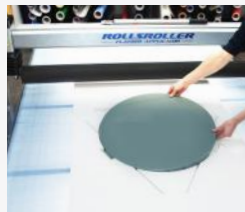
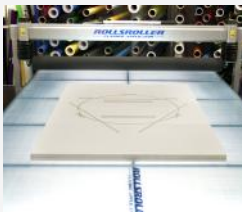

MODEL NAME	DESCRIPTION/DIMENSIONS	PART NO.
Customized Jig	Customized for your sign standards. For traffic sign manufacturing	10528

GUIDE SIGN JIG

GUIDE SIGN JIG IS AN FLEXIBLE ACCESSORY THAT IS USED ON A ROLLERSROLLER® with flatbed worktable (does not fit model Traffic).

The Jig stays directly on the bed and creates a support when applying to bent metal plates and extruded panels like guide signs.

Custom size: Made to order with maximum length: 6 000 mm / 19ft. 8in

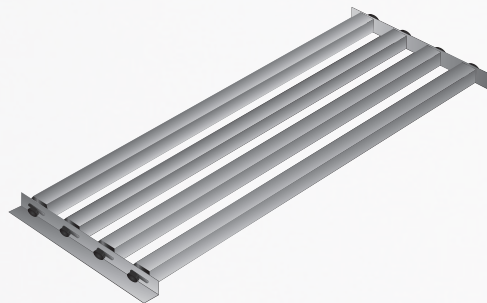

MODEL NAME	DESCRIPTION/DIMENSIONS	PART NO.
Guide Sign Jig 200/40	Length: 2 000 mm / 6ft. 6in. Width: 400 mm / 1ft. 3in.	10131
Guide Sign Jig 400/40	Length: 4 000 mm / 13ft. 2in. Width: 400 mm / 1ft. 3in.	10405

ROLLSROLLER®

— FLATBED APPLICATOR —

For any product queries please contact your Spicers representative,
or your local branch from the list below.

Victoria

155 Logis Boulevard
Dandenong South
Victoria 3175

T (03) 9768 8400
F (03) 9768 8401
info.vic@spicers.com.au

NSW

Unit 2, 100 Lockwood Road
Erskine Park
NSW 2759

T (02) 9735 2666
F (02) 9735 2600
salesnsw@spicers.com.au

QLD Brisbane

75 Tradecoast Drive
Eagle Farm
QLD 4009

T (07) 3084 5200
F (07) 3084 5297
info.qld@spicers.com.au

QLD Townsville

28A Casey Street
Aitkenvale
Queensland 4818

T (07) 3084 5200
F (07) 3084 5297
info.qld@spicers.com.au

Western Australia

19 Milly Court
Malaga
Western Australia 6090

T (08) 6310 4300
F (08) 9248 6515
info.wa@spicers.com.au

Northern Territory

57 Winnellie Road
Winnellie
Northern Territory 0820

T (08) 8947 0188
F (08) 8947 1366
info.nt@spicers.com.au

South Australia

113 Ledger Road
Beverley
South Australia 5009

T (08) 8243 9393
F (08) 8243 9397
info.sa@spicers.com.au

Tasmania

4-8 Sunmont Street
Derwent Park
Tasmania 7009

T (03) 6272 5333
F (03) 6272 8103
info.tas@spicers.com.au

