



RE-NEET

2026

QUESTION PAPER

PDFs

Download Now



High Quality
PDFs



Latest
Question Papers



Easy
Download



100%
Reliable



CALL / WHATSAPP

72030 86849



www.sartha.in

Do not open this Test Booklet until you are asked to do so.

Important Instructions :

1. The Answer Sheet is inside this Test Booklet. When you are directed to open the Test Booklet, take out the Answer Sheet and fill in the particulars on ORIGINAL Copy carefully with **blue/black** ball point pen only.
2. The test is of **3 hours 15 minutes** duration and the Test Booklet contains **180** multiple-choice questions (four options with a single correct answer) from **Physics, Chemistry and Biology (Botany and Zoology)**.
3. Wherever the symbols/constants are not mentioned, they are to be considered as per their standard meaning/value.
4. Each question carries **4** marks. For each correct response, the candidate will get **4** marks. For each incorrect response, **one** mark will be deducted from the total scores. **The maximum marks are 720.**
5. Use **Blue/Black Ball Point Pen only** for writing particulars on this page/markings responses on Answer Sheet.
6. Rough work is to be done in the space provided for this purpose in the Test Booklet only.
7. On completion of the test, the candidate **must handover the Answer Sheet (ORIGINAL and OFFICE Copy) to the Invigilator** before leaving the Room/Hall. The candidates are allowed to take away this Test Booklet with them.
8. **The CODE for this Booklet is 70. Make sure to enter this code in the OMR answer sheet.**
9. The candidates should ensure that the Answer Sheet is not folded. Do not make any stray marks on the Answer Sheet. Do not write your Roll No. anywhere else except in the specified space in the Test Booklet/Answer Sheet.
10. Use of white fluid for correction is **NOT** permissible on the Answer Sheet.
11. Each candidate must show on-demand his/her Admit Card to the Invigilator.
12. No candidate, without special permission of the centre Superintendent or Invigilator, would leave his/her seat.
13. The candidates should not leave the Examination Hall without handing over their Answer Sheet to the Invigilator on duty and sign (with time) the Attendance Sheet twice. **Cases, where a candidate has not signed the Attendance Sheet second time, will be deemed not to have handed over the Answer Sheet and dealt with as an Unfair Means case.**
14. Use of Electronic/Manual Calculator is prohibited.
15. The candidates are governed by all Rules and Regulations of the examination with regard to their conduct in the Examination Room/Hall. All cases of unfair means will be dealt with as per the Rules and Regulations of this examination along with Public Examinations (Prevention of unfair means act 2024).
16. **No part of the Test Booklet and Answer Sheet shall be detached under any circumstances.**
17. The candidates will write the Correct Test Booklet Code as given in the Test Booklet/Answer Sheet in the Attendance Sheet.
18. If a candidate marks more than one answers for a question in the OMR sheet, it will be treated as incorrect and negative marking will be applicable.

Name of the Candidate (in Capitals) : ANSAR-ANKTER LOVE

Roll Number : in figures 2502214139

: in words Twofive zero two two one four one three nine

Centre of Examination (in Capitals) : VISHWA BHARTI WOMEN'S COLLEGE

Candidate's Signature : [Signature] Invigilator's Signature : [Signature]

Facsimile signature stamp of Centre Superintendent : [Signature]

SEAL

4. A photon and an electron, each of 20 eV energy, move in free space. The ratio of linear momentum of electron p_e to that of photon p_{ph} , $\frac{p_e}{p_{ph}}$ is :

- (1) 275
- (2) $\frac{450}{2}$
- (3) $\frac{250}{1}$
- (4) 225

(Take speed of light = 3×10^8 ms⁻¹, charge of electron = -1.6×10^{-19} C and mass of electron = 9×10^{-31} kg)

2. Water flows in a streamline motion through a horizontal pipe of circular cross-section as shown in the figure. The pressure difference of water between P and Q is 15 Nm^{-2} . The area of cross-section at P and Q are 40 cm^2 and 20 cm^2 , respectively. The rate of flow of water through the pipe, in $\text{cm}^3 \text{ s}^{-1}$, is :

- (1) 400
- (2) 100
- (3) 200
- (4) 300

3. A thin horizontal disc is rotating about a vertical axis passing through its fixed centre O. Its angular momentum is L_A and L_B computed about points A and B, respectively, with $OB = 2 \times OA$. The value of $\frac{L_B}{L_A}$ is :

- (1) 2
- (2) $\frac{1}{4}$
- (3) $\frac{1}{2}$
- (4) 1

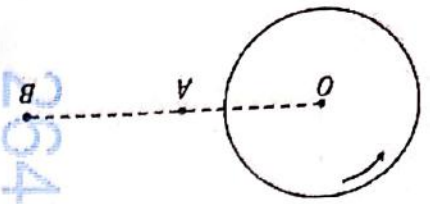

5. The temperature of a metallic sphere of radius R is increased by a small amount ΔT . If the linear coefficient of thermal expansion of the metal is α , the approximate increase in the volume of the sphere is :

- (1) $6\pi R^3 \alpha \Delta T$
- (2) $2\pi R^3 \alpha \Delta T$
- (3) $3\pi R^3 \alpha \Delta T$
- (4) $4\pi R^3 \alpha \Delta T$

6. Consider two resistors, (A) and (B), each having two resistors. One of them has a positive temperature coefficient of resistance, $+\alpha$, while the other one has a negative temperature of coefficient, $-\alpha$, as shown in the figure. The current through these circuits are denoted by I_A and I_B . At initial temperature, the resistance of the two resistors is R_0 . As the temperature is increased, the correct option that describes the variation of current in these circuits is :

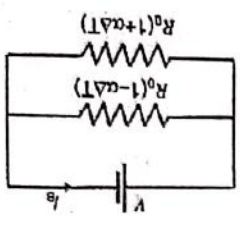
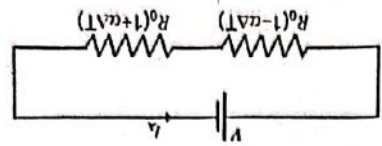

- (1) both I_A and I_B remain constant
- (2) I_A remains constant while I_B increases
- (3) I_A decreases while I_B increases
- (4) I_A increases while I_B decreases

Consider a long solenoid of length l and radius r . If n is the number of turns per unit length and μ_0 is the permeability of free space, the inductance of the solenoid is :

- (1) $2\mu_0 \pi n^2 r^2 l$
- (2) $\mu_0 \pi n^2 r^2 l$
- (3) $\mu_0 n^2 r^2 l$
- (4) $(\mu_0 / 2\pi) n^2 r^2 l$

In the measurement of viscosity of liquids using terminal velocity experiment, spherical balls of same radius but having different densities are used. The variation of the terminal velocity (v) with the ratio of density of spherical ball (σ) to density of the liquid (ρ), is best represented by :

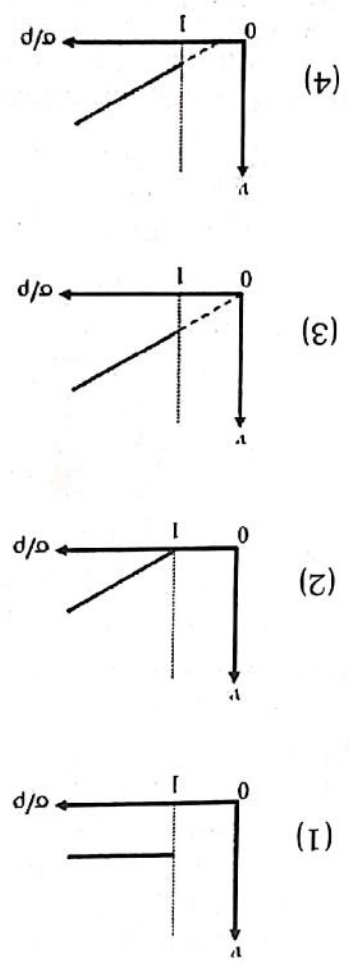

9. A beam of light falls on a metal surface such that photo-electrons are generated. If power of the light source starts to decrease linearly with time t , then variation of the photocurrent I and magnitude of the stopping potential $|V|$ with time is best represented by :

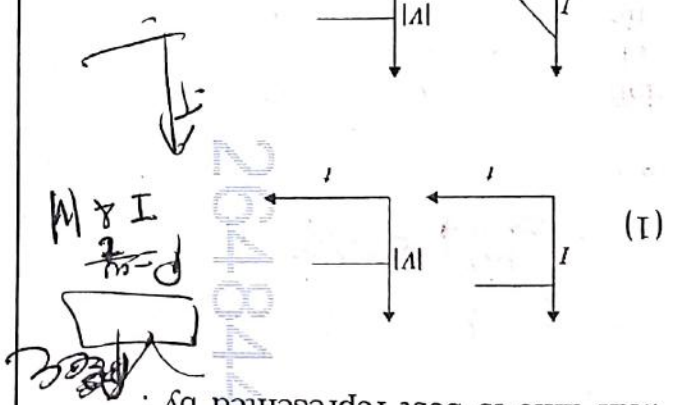

$P \propto I \propto W$

8. An ideal Zener diode with breakdown voltage of -3 V is reverse biased with a negative input voltage $V_i = -5\text{ V}$. The magnitude of voltage difference between points B and A is :

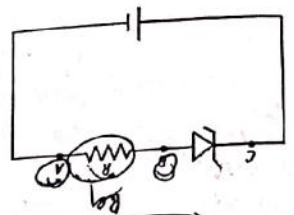

- (1) 0 V
- (2) 3 V
- (3) 2 V
- (4) 1 V

10. Two planets P_1 and P_2 with equal mass have radii R_1 and R_2 , respectively, where $R_2 = \frac{R_1}{2}$. The escape speeds of P_1 and P_2 are v_1 and v_2 , respectively. Then $\frac{v_1}{v_2}$ is :

- (1) 2
- (2) $\frac{\sqrt{2}}{1}$
- (3) 1
- (4) $\sqrt{2}$

2648441105

2648441067

2648441105

11. An ac voltage $V = 220 \sin(2 \times 10^3 t)$ Volt is applied to a series LCR circuit. Then the current amplitude in this circuit is :
 (Given : $L = 10 \text{ mH}$, $C = 25 \mu\text{F}$, $R = 100 \Omega$)
 (1) 22.0 A
 (2) 2.2 A
 (3) 5.5 A
 (4) 11.0 A

12. Two identical inductors are connected in two different configurations P and Q, where a time varying current $I(t)$ is flowing, as shown in the figure. The induced emf between points a and b for configuration P is E_P and that for configuration Q is E_Q . The ratio E_P/E_Q is :
 [Neglect the effect of mutual inductance.]

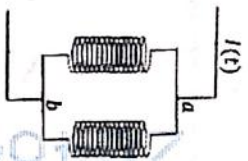
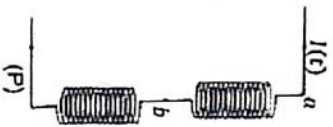

- (1) 2
 (2) 1/4
 (3) 1/2
 (4) 1

13. Three identical capacitors P, Q and S, each of the capacitance C, are connected to a battery of voltage V, as shown in the figure. If the energy stored in the capacitor P and total energy stored in the system are U_P and

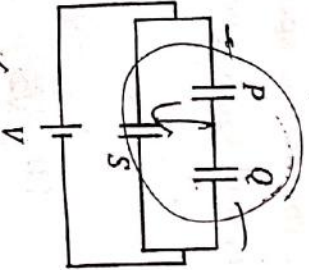

U_T , respectively, then the ratio $\frac{U_P}{U_T}$ is :

$U_P = \frac{1}{2} C V^2$
 $U_T = \frac{1}{2} (C + C) V^2 = C V^2$
 $\frac{U_P}{U_T} = \frac{\frac{1}{2} C V^2}{C V^2} = \frac{1}{2}$

- (1) 1/6
 (2) 2/3
 (3) 1/3
 (4) 1/2

14. A conducting loop of finite resistance lies on the x - y plane. There is a constant magnetic field in the z direction. The area of the loop varies with time t, as $A = A_0(1 + \sin t)$ in appropriate units. The figure that correctly indicates the qualitative behaviour of the power P dissipated in the loop as a function of time is :

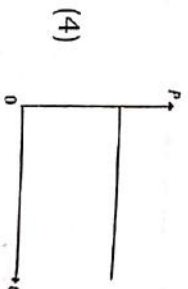
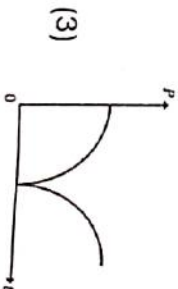
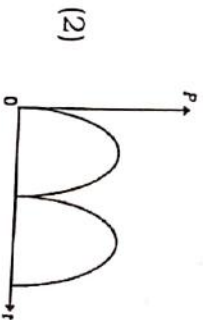
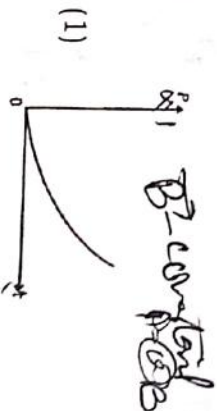

15. In an adiabatic expansion, the temperature of one mole of an ideal monatomic gas ($\gamma = 5/3$) decreases from 60K to 50K. The work done by the gas in the process is :
 (Take the universal gas constant as $R = 8.3 \text{ J mol}^{-1} \text{ K}^{-1}$)
 (1) 166 J
 (2) 41.5 J
 (3) 83 J
 (4) 124.5 J

$$s = u + at$$

16. Consider a particle moving along a straight line, whose position as a function of time is given by $s(t) = \alpha t^2 - \beta t + \gamma$, where $\alpha = 1 \text{ ms}^{-2}$, $\beta = 6 \text{ ms}^{-1}$ and $\gamma = 5 \text{ m}$. The average speed of the particle, in ms^{-1} , from $t=0$ to $t=6 \text{ s}$ is :

- (1) 0 (2) 12
 (3) 6 (4) 3

17. The following table presents the part of the electromagnetic spectrum and their corresponding major applications.

Part of the electromagnetic spectrum	Applications
P Microwave	I For purifying the water
Q UV rays	II For warming the food
R Gamma rays	III For AM and FM communication systems
S Radio wave	IV For treating the Cancer cells

The correct option is :

- (1) P-II, Q-IV, R-III, S-I ✓
 (2) P-I, Q-II, R-III, S-IV ✗
 (3) P-I, Q-IV, R-II, S-III ✗
 (4) P-II, Q-I, R-IV, S-III ✗

$$S = IV$$

18. An ideal gas is made of polyatomic molecules. Each of the molecules has three translational, three rotational and three vibrational modes. If the f number of vibrational modes of the gas is $8/7$, then the value of f is :

- (1) 1 (2) 4
 (3) 3 (4) 2

19.

A unit positive point charge is taken slowly through an infinitesimally thin tube that is inside a charged dielectric sphere of radius R , having uniform positive charge density ρ , as shown in the figure. The initial and final positions of the charge are marked by A and B at distances $2R$ and $3R$ respectively, from the centre of the sphere. In this process, the magnitude of the total work done on the point charge is $\frac{\rho R^2}{n\epsilon_0}$. The

value of n is :

(ϵ_0 is the permittivity of vacuum)

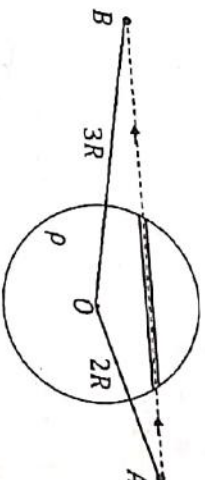

- (1) 18 (2) 2
 (3) 6 (4) 9

20. A current I_0 flows through a metallic circular loop of radius r as shown in the figure. Resistance of the segment ABC is half that of ADC. Magnitude of magnetic field at the center O of the loop is :

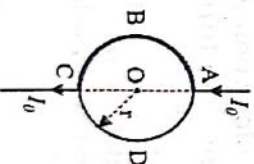

- (1) $\frac{\mu_0 I_0}{2\pi r}$ (2) $\frac{\mu_0 I_0}{12r}$
 (3) $\frac{\mu_0 I_0}{4r}$ (4) $\frac{\mu_0 I_0}{2r}$

21. Bob B of mass m at rest is hanging vertically from the ceiling via a massless string of length 10 m, as shown in the figure. Point mass A of mass m travelling horizontally with speed 10 ms^{-1} hits bob B elastically. The bob B rises h meter after the collision. Taking the acceleration due to gravity $g = 10 \text{ ms}^{-2}$ and neglecting the size of the bob, the value of h is :

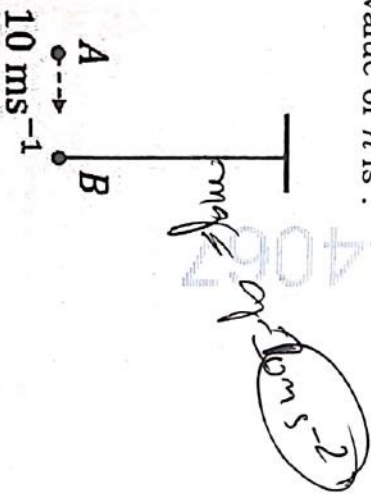

- (1) 2.5 (2) 8
 (3) 7 (4) 50

22. An electromagnetic wave travelling in a lossless dielectric medium having a dielectric constant, $\epsilon_r = 9$, has the electric field, $E_x = E_0 \sin(kz - 2\pi \times 10^6 t) \text{ Vm}^{-1}$ where E_0 is the amplitude and k is the wave vector. Among the following options, the **incorrect** choice is :

- (1) The direction of propagation of the electromagnetic wave is along $+z$
 (2) The speed of the electromagnetic wave inside the medium is 10^8 ms^{-1}
 (3) The wavelength of the electromagnetic wave inside the medium is 300 m
 (4) The magnetic field is given by the relation $B_y = \frac{E_0}{c} \sin(kz - 2\pi \times 10^6 t)$ where v is the speed of the electromagnetic wave inside the medium

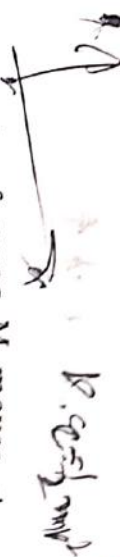

23. A particle of mass M moves along a horizontal x axis from $x=0$ to $x=L$. The coefficient of kinetic friction varies as a function of x as $\mu_k(x) = \mu_0 - \alpha x$, where μ_0 and α are constants of appropriate dimensions, so that $\mu_k(L) = 0$. The total work done by the frictional force during the motion is $\frac{1}{2} \mu_0 M g L$, where g is the acceleration due to gravity. The value of n is :

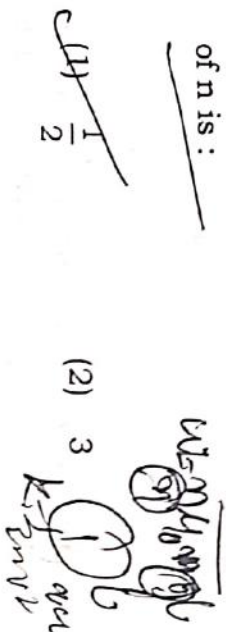

- (1) $\frac{1}{2}$ (2) 3
 (3) 1 (4) $\frac{1}{3}$

24. Consider three media P, Q and R with refractive indices 1, 1.25, and 1.5, respectively. The medium Q having a thickness of 5 cm is placed between extended media P and R as shown in the figure. An object O is placed at the center of medium Q. If viewed from the center of medium P near the normal direction, the apparent depth of O is h_1 . For similar observation from medium R, the apparent depth is h_2 . The value of $|h_1 - h_2|$, in cm, is :

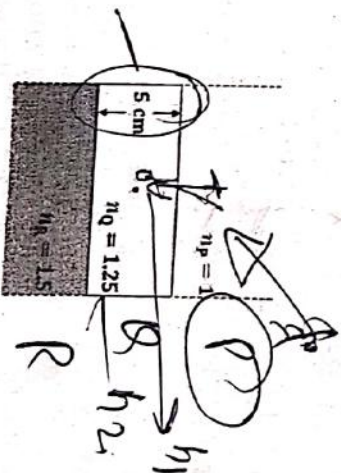

- (1) 3 (2) 0
 (3) 1 (4) 2

25. Consider a fixed uniformly charged insulating sphere with radius R and total charge $+Q$. A point charge $-q$ ($q < Q$) with mass m is released from rest at a distance of $3R$ from the centre of the charged sphere. When the point charge reaches the surface of the sphere, its speed is :

(1) $\sqrt{\frac{Qq}{4\pi\epsilon_0 mR}}$

(2) $\sqrt{\frac{3Qq}{4\pi\epsilon_0 mR}}$

(3) $\sqrt{\frac{2Qq}{3\pi\epsilon_0 mR}}$

(4) $\sqrt{\frac{Qq}{3\pi\epsilon_0 mR}}$

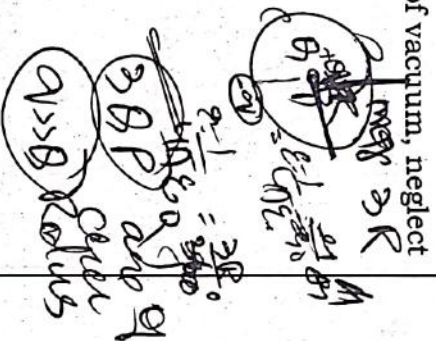

26. A car travels on a circular racetrack of radius 50 m, which is banked at an angle θ . If the car travels at a speed 10 ms^{-1} , then the wear and tear on its tyres is minimum. Taking the acceleration due to gravity to be 10 ms^{-2} , the value of θ is :

(1) $\tan^{-1}(2\sqrt{3})$

(2) $\tan^{-1}\left(\frac{1}{5}\right)$

(3) $\tan^{-1}\left(\frac{2}{5}\right)$

(4) $\tan^{-1}\left(\sqrt{3}/2\right)$

27. A frictionless circular wire of unit radius is fixed on the horizontal plane. Two point particles of unit mass start moving simultaneously from point A ($\theta = \frac{\pi}{2}$) with identical uniform angular speeds in opposite directions, and meet again at point B ($\theta = -\frac{\pi}{2}$). During this time, which of the following figures schematically represent the magnitude of the total linear momentum P of the system, as a function of θ ?

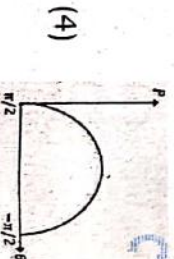
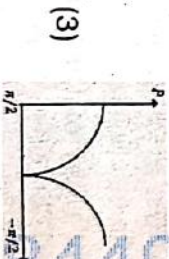
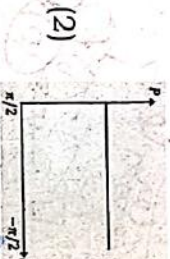
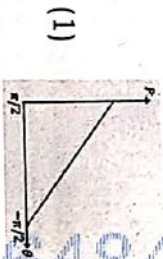
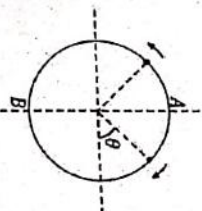

28. Three identical p-n junction diodes D_1 , D_2 and D_3 are connected across a battery as shown in the figure. If the width of the depletion regions of D_1 , D_2 and D_3 are W_1 , W_2 and W_3 , respectively, then the correct option is :

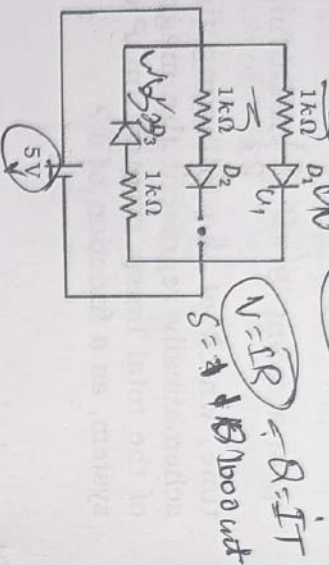

- (1) $W_2 > W_1 = W_3$
 (2) $W_1 > W_2 > W_3$
 (3) $W_3 = W_1 > W_2$
 (4) $W_3 > W_2 > W_1$

29. The lens combination as shown in the figure, consists of two lenses, L_1 and L_2 , of the focal lengths $+10$ cm and -10 cm, respectively. The position of the image formed is :

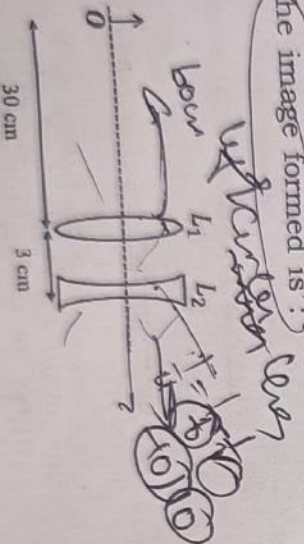

- (1) 60 cm to the right of the concave lens
 (2) 20 cm to the left of the concave lens
 (3) 60 cm to the left of the concave lens
 (4) 30 cm to the right of the concave lens

30. A solid sphere A of radius R and mass M is attached at a point to a smaller solid sphere B of radius $r < R$ and mass $m < M$. Assume that the line joining their centres lies along the horizontal. The moment of inertia of the system calculated about a vertical axis passing through the centre of A is I_A and that calculated about a vertical axis passing through the centre of B is I_B . The difference $I_A - I_B$ is :

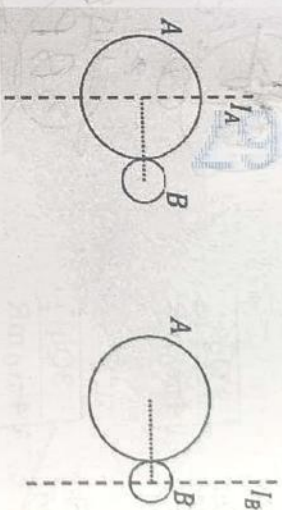

- (1) 0
 (2) $(M - m)(R + r)^2$
 (3) $(m - M)(R + r)^2$
 (4) $(m - M)(R - r)^2$

31. Consider that an electron is revolving in an excited state of Hydrogen atom with velocity $\sqrt{25.6} \times 10^5 \text{ ms}^{-1}$. The radius of the orbit is $x \times 10^{-9} \text{ m}$. The value of x is :

[Take the mass of electron to be $9 \times 10^{-31} \text{ kg}$, charge of electron

$$= -1.6 \times 10^{-19} \text{ C and } \frac{1}{4\pi\epsilon_0} = 9 \times 10^9 \text{ N}$$

$$\text{m}^2 \text{ C}^{-2}]$$

- (1) 1 (2) 4
 (3) 3 (4) 2

32. The mean free path of molecules in an ideal gas A is half that of another ideal gas B. The diameter of the spherical molecules of gas A is twice the diameter of the molecules of B. If number densities of the gases of A and B are n_A and n_B , respectively, then the correct option is :

(1) $n_A = \frac{1}{2} n_B$ (2) $n_A = n_B$

(3) $n_A = 2n_B$ (4) $n_A = \frac{1}{4} n_B$

48. The lanthanide ion having four unpaired electrons is

- (1) Nd^{3+}
- (2) Ho^{3+}
- (3) Ce^{3+}
- (4) Tb^{3+}

(Given : Atomic numbers of Ce = 58, Nd = 60, Tb = 65 and Ho = 67)

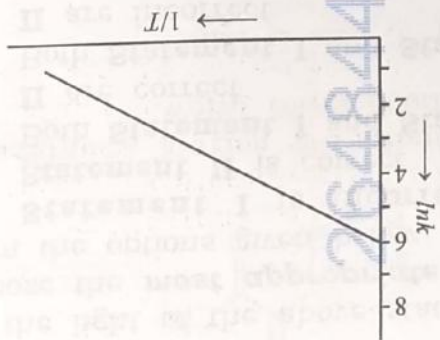

49. For an elementary chemical reaction, the Arrhenius plot is given below.

If the energy of activation is 6.64 kJ mol^{-1} and $R = 8.3 \text{ J K}^{-1} \text{ mol}^{-1}$, the temperature at which the rate constant becomes $e^2 \text{ min}^{-1}$, is

- (1) 250 K
- (2) 125 K
- (3) 150 K
- (4) 200 K

50. The green paramagnetic species formed by heating KMnO_4 at 513 K is

- (1) K_2MnO_4
- (2) K_2MnO_4
- (3) Mn_3O_4
- (4) MnO

46. Consider the following reaction, and choose the correct option.

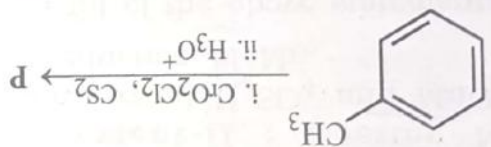

(1) Compound P is obtained by the hydrogenation of benzoyl chloride with Pd on BaSO_4 .

(2) On treating compound P with saturated NaHCO_3 solution, brisk effervescence is observed.

(3) Compound P can be prepared by treating benzene with anhydrous AlCl_3 and CH_3COCl .

(4) On treatment with bromine water, compound P gives a white precipitate.

47. The formula of tetraammineaquachloridocobalt(III) chloride is

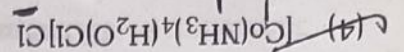
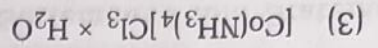
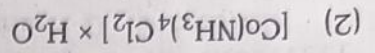
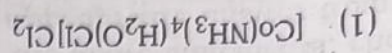

choose the correct option.

51. Given below are two statements:

Statement I:

trans-But-2-ene upon treatment with Br_2 in CCl_4 gives the following product



Statement II:

cis-But-2-ene upon treatment with alkaline $KMnO_4$ gives the following product

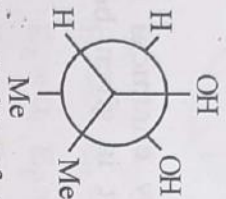

In the light of the above statements, choose the **most appropriate** answer from the options given below.

- (1) **Statement I** is incorrect but **Statement II** is correct
- (2) Both **Statement I** and **Statement II** are correct
- (3) Both **Statement I** and **Statement II** are incorrect
- (4) **Statement I** is correct but **Statement II** is incorrect

52. One of the products formed in the following reaction is

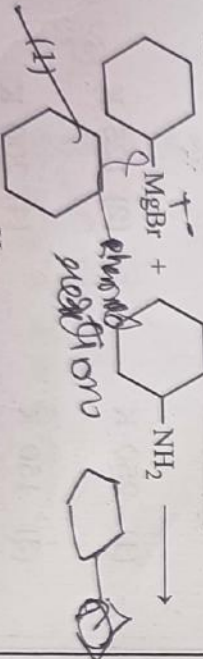

- (1)
- (2)
- (3)
- (4)

53. Given below are two statements:

Statement-I : Heating $NaCl$ with concentrated H_2SO_4 and MnO_2 results in oxidation of Mn .

Statement-II : Heating NaI with concentrated H_2SO_4 and MnO_2 results in reduction of Mn .

In light of the above statements, choose the **most appropriate** answer from the options given below:

- (1) **Statement-I** is incorrect but **Statement-II** is correct.
- (2) Both **Statement-I** and **Statement-II** are correct.
- (3) Both **Statement-I** and **Statement-II** are incorrect.
- (4) **Statement-I** is correct but **Statement-II** is incorrect.

54. Among the following options, the correct trend in the electron gain enthalpy is

- (1) $I > Br > Cl > F$
- (2) $F > Cl > Br > I$
- (3) $Br > Cl > F > I$
- (4) $Cl > F > Br > I$

55. Given below are two statements:

Statement-I : $[Fe(ox)_3]^{3-}$ is chiral.

Statement-II : *trans*- $[Cr(H_2O)_2(ox)_2]$ is chiral.

(Given : $oxH_2 = HOOC-COOH$)

In light of the above statements, choose the **most appropriate** answer from the options given below:

- (1) **Statement-I** is incorrect but **Statement-II** is correct.
- (2) Both **Statement-I** and **Statement-II** are correct.
- (3) Both **Statement-I** and **Statement-II** are incorrect.
- (4) **Statement-I** is correct but **Statement-II** is incorrect.

56. The correct statement about peptides and proteins is

- (1) In α -helices, the polypeptide chain is twisted into a left-handed screw (helix) through intramolecular hydrogen bonds.
- (2) Tertiary structure of proteins has two or more polypeptide subunits.
- (3) Only the proteins having a quaternary structure are biologically active.

(4) In β -pleated sheet structures, peptide chains are held together by intermolecular hydrogen bonds.

57. Given below are two statements:

Statement-I : Oxidation of p -nitrotoluene with acidic KMnO_4 gives an acid that is stronger than benzoic acid.

Statement-II : Reduction of p -nitrotoluene with Sn/HCl followed by neutralization gives an amine that is more basic than aniline.

In light of the above statements, choose the **most appropriate** answer from the options given below.

- (1) **Statement-I** is incorrect but **Statement-II** is correct.
- (2) Both **Statement-I** and **Statement-II** are correct.
- (3) Both **Statement-I** and **Statement-II** are incorrect.
- (4) **Statement-I** is correct but **Statement-II** is incorrect.

58. Identify the reactions which give aniline as the major product.

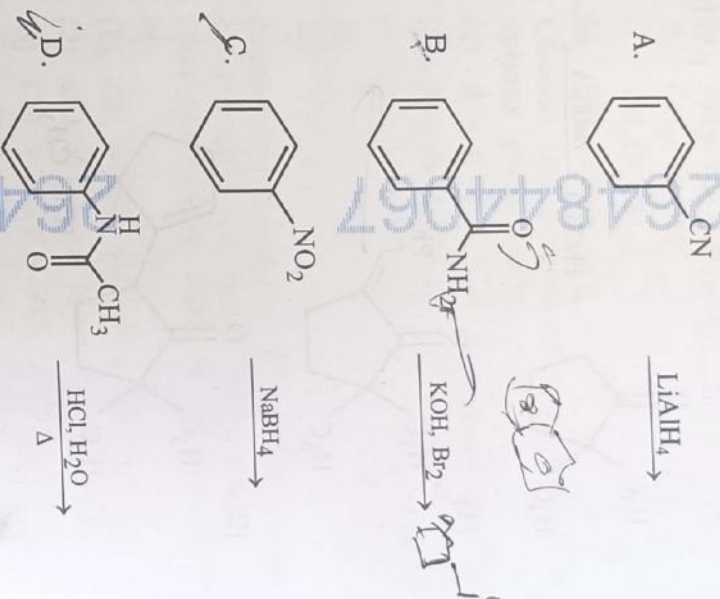

Choose the correct answer from the options given below.

- (1) C and D only
- (2) A and B only
- (3) B and D only
- (4) A and C only

59. Two moles of an ideal gas undergo free expansion from 10 L to 100 L at 300 K. The values of ΔS_{system} and $\Delta S_{\text{surroundings}}$ are

(R is universal gas constant)

- (1) $\Delta S_{\text{system}} = 4.606 R$; $\Delta S_{\text{surroundings}} = 0$
- (2) $\Delta S_{\text{system}} = 0$; $\Delta S_{\text{surroundings}} = 0$
- (3) $\Delta S_{\text{system}} = 4.606 R$; $\Delta S_{\text{surroundings}} = -4.606 R$
- (4) $\Delta S_{\text{system}} = 0$; $\Delta S_{\text{surroundings}} = 4.606 R$

Red A 16
old C 34
Δ cases

60. The compound that **CANNOT** be obtained from the aldol condensation reaction shown below, is

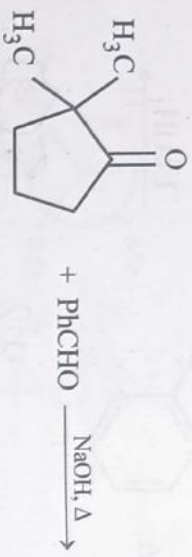

- (1) CC1(C)CCCC1=Cc2ccccc2
- (2) CC1(C)CCCC1=Cc2ccccc2
- (3) CC1(C)CCCC1=Cc2ccccc2
- (4) CC1(C)CCCC1=Cc2ccccc2

61. The complex which has *facial* and *meridional* isomers is

(Given : py = pyridine and en = H₂N-CH₂-CH₂-NH₂)

- (1) [Ni(en)₂(H₂O)₂]²⁺
- (2) [Cr(py)₃(Cl)₃]
- (3) [Cr(H₂O)₆]³⁺
- (4) [Co(NH₃)₄(H₂O)₂]³⁺

62. The numbers 17.0145 and 21.0235 were rounded to three figures after the decimal point. The resulting numbers, respectively, are

(1) 17.015 and 21.024

(2) 17.014 and 21.023

(3) 17.015 and 21.023

(4) 17.014 and 21.024

63. The amount of carbon dioxide evolved upon complete combustion of 116 g of n-butane is

(Given: atomic mass in amu H = 1, C = 12 and O = 16)

(1) 362 g

(2) 352 g

(3) 322 g

(4) 176 g

64. Consider the following schematic plots of orbital wavefunction (ψ_r) against distance (r) from the nucleus.

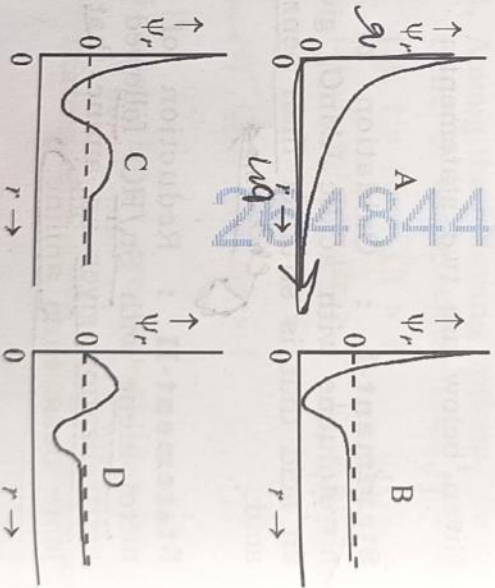

The figure representing two radial nodes in the orbital is

(1) D

(2) A

(3) B

(4) C

65. The following carbocation is stabilized by the interaction of the empty p orbital with

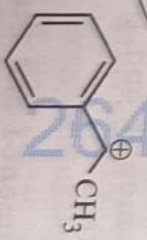

- (1) empty σ* and empty π* orbitals
- (2) filled σ and filled π orbitals
- (3) empty σ and empty π* orbitals
- (4) empty σ* and filled π orbitals

66. A 1:3 electrolyte in an aqueous solution is
- $[\text{Co}(\text{NH}_3)_3(\text{NO}_2)_3]$
 - $[\text{CoCl}_2(\text{NH}_3)_4]\text{Cl}$
 - $[\text{CoCl}(\text{NH}_3)_5]\text{Cl}_2$
 - $[\text{Co}(\text{NH}_3)_6]\text{Cl}_3$
67. The standard electrode potential (E^\ominus) for the half-cell reaction $\text{Fe}^{3+} + e^- \rightarrow \text{Fe}^{2+}$ at 298 K is -0.04 V and (Given: $E^\ominus(\text{Fe}^{3+}/\text{Fe}) = -0.44 \text{ V}$ at 298 K)
- $$E^\ominus(\text{Fe}^{2+}/\text{Fe}) = -0.44 \text{ V} + 0.04 \text{ V} = -0.40 \text{ V}$$
- $$E^\ominus(\text{Fe}^{2+}/\text{Fe}) = -0.40 \text{ V}$$
- $$E^\ominus(\text{Fe}^{2+}/\text{Fe}) = -0.40 \text{ V}$$
68. In potash alum, the ratio of K^+ and SO_4^{2-} ions is
- 3:2
 - 1:2
 - 2:1
 - 2:3
69. Consider the following statements about the solutions formed by mixing two liquids.
- An ideal solution thus formed obeys Raoult's law throughout the composition range.
 - Mixture of chloroform and acetone shows negative deviation from Raoult's law.
 - Mixture of aniline and phenol shows positive deviation from Raoult's law.
70. For a salt **XY**, which is a strong electrolyte, the plot of Δ_m versus \sqrt{C} has a slope of $-90.0 \text{ S cm}^2 \text{ mol}^{-3/2} \text{ L}^{1/2}$ at 298 K. At 0.01 M concentration of **XY**, the value of Δ_m is $145.0 \text{ S cm}^2 \text{ mol}^{-1}$. The limiting molar conductivity of **Y**-ion ($\Delta_{\text{Y}^-}^0$, in $\text{S cm}^2 \text{ mol}^{-1}$) at 298 K will be
- (Given: $\Delta_{\text{X}^+}^0 = 74.0 \text{ S cm}^2 \text{ mol}^{-1}$)
- 76.0
 - 80.0
 - 100.0
 - 90.0
71. Arrange the following compounds in the increasing order of polarity
- $\text{CH}_3\text{CH}_2\text{OCH}_2\text{CH}_3$
 - $\text{CH}_3\text{CH}_2\text{OH}$
 - CH_3COCH_3
 - CH_3COOH
- Choose the correct answer from the options given below.
- $\text{A} < \text{C} < \text{B} < \text{D}$
 - $\text{A} < \text{B} < \text{C} < \text{D}$
 - $\text{C} < \text{A} < \text{D} < \text{B}$
 - $\text{C} < \text{A} < \text{B} < \text{D}$
72. According to crystal field theory, the correct order of ligands with respect to their decreasing order of field strength is
- $\text{Cl}^- > \text{NH}_3 > \text{H}_2\text{O} > \text{CO}$
 - $\text{CO} > \text{NH}_3 > \text{H}_2\text{O} > \text{Cl}^-$
 - $\text{CO} > \text{H}_2\text{O} > \text{NH}_3 > \text{Cl}^-$
 - $\text{Cl}^- > \text{H}_2\text{O} > \text{NH}_3 > \text{CO}$
73. The amino acid that gives a red-blood colour on treating its sodium fusion extract with sodium nitroprusside is
- serine
 - leucine
 - threonine
 - methionine
74. In an acidic medium, 10 mL of 0.25 M oxalic acid is titrated with KMnO_4 solution. If the volume of KMnO_4 solution required to reach end point is 10 mL, the strength of the KMnO_4 solution is
- 0.15 M
 - 0.10 M
 - 0.20 M
 - 0.25 M
75. The correct statement is
- Aluminium has five valence orbitals.
 - Boron has a maximum covalency of four.
 - Beryllium has three valence orbitals.
 - Magnesium has a maximum covalency of four.

76. Among the following, the compound having conjugated double bonds is

- (1) hepta-1,6-diene
 (2) hepta-1,3-diene
 (3) hepta-1,4-diene
 (4) hepta-1,5-diene



77. $2A \xrightarrow{k} B$ is a zero-order reaction, where $k = 1.0 \text{ mol L}^{-1} \text{ min}^{-1}$. If the initial concentration of A is 2 M , then the time taken to complete 75% of the reaction will be

- (1) 2.0 min (2) 1.5 min
 (3) 0.75 min (4) 1.0 min

Handwritten notes: $A = 2 \text{ M}$, $k = 1.0$, $t = 1.5 \text{ min}$, $A = 0.5 \text{ M}$, $t = 1.5 \text{ min}$, $t = 1.5 \text{ min}$

78. The correct order of solubility of the given salts in water at 298 K is

Salt	K_{sp} at 298 K
AgBr	5.0×10^{-13}
$\text{Zn}(\text{OH})_2$	1.0×10^{-15}
Hg_2Cl_2	1.3×10^{-18}

- (1) $\text{Zn}(\text{OH})_2 > \text{AgBr} > \text{Hg}_2\text{Cl}_2$
 (2) $\text{Hg}_2\text{Cl}_2 > \text{Zn}(\text{OH})_2 > \text{AgBr}$
 (3) $\text{AgBr} > \text{Zn}(\text{OH})_2 > \text{Hg}_2\text{Cl}_2$
 (4) $\text{Hg}_2\text{Cl}_2 > \text{AgBr} > \text{Zn}(\text{OH})_2$

79. The correct decreasing order of oxidation state of the underlined atom in each molecule is

- (1) $\text{P}_4\text{O}_6 > \text{Cl}_2\text{O}_7 > \text{AlH}_3$
 (2) $\text{P}_4\text{O}_{10} > \text{SO}_3 > \text{H}_2\text{O}$
 (3) $\text{N}_2\text{O}_5 > \text{Al}_2\text{O}_3 > \text{H}_2\text{S}$
 (4) $\text{PbO}_2 > \text{N}_2\text{O}_3 > \text{SO}_3$

80. Consider the reversible processes for 1.0 mol of an ideal gas as shown in the figure.

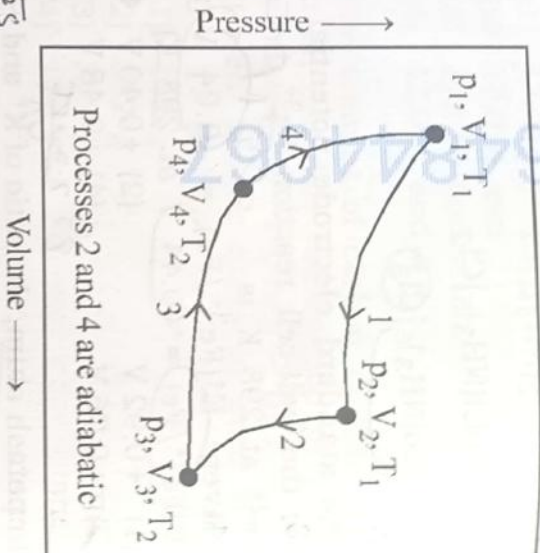

w_1, w_2, w_3 and w_4 represent work done (in calories) in the processes 1, 2, 3 and 4, respectively; ΔU_2 and ΔU_4 are changes in the internal energy for the processes 2 and 4, respectively.

[use $R = 2 \text{ cal K}^{-1} \text{ mol}^{-1}$]
 The correct option is

- (1) $w_1 + w_2 + w_3 + w_4 = 0$
 (2) $w_1 + w_3 = -2T_1 \ln \frac{V_2}{V_1} - 2T_2 \ln \frac{V_4}{V_3}$
 (3) $w_2 + w_4 = \Delta U_2 - \Delta U_4$
 (4) $w_1 + w_2 = 2T_1 \ln \frac{V_2}{V_1}$

81. Assertion A :

For an ideal solution formed by mixing liquids P and Q, $\Delta_{mix} V = 0$

Reason R :

No interactions occur between P and Q. In the light of the above statements, choose the most appropriate answer from the options given below.

- (1) A is not correct but R is correct
 (2) Both A and R are correct and R is the correct explanation of A
 (3) Both A and R are correct but R is NOT the correct explanation of A
 (4) A is correct but R is not correct

88. Match the species in List I with their geometry in List II

List I List II

- A. PCl_5 Tetrahedral
 B. BrF_5 Square Planar
 C. BF_4^- Trigonal bipyramidal
 D. $[\text{Ni}(\text{CN})_4]^{2-}$ Square pyramidal

Choose the correct answer from the options given below:

- (1) A-III, B-II, C-I, D-IV
 (2) A-IV, B-III, C-I, D-II
 (3) A-III, B-IV, C-I, D-II
 (4) A-III, B-I, C-II, D-IV

89. Match the vitamins in List I with their sources in List II

List I List II

- A. vitamin A meat
 B. vitamin B_{12} sunflower oil
 C. vitamin E green leafy vegetables
 D. vitamin K carrots

Choose the correct answer from the options given below.

- (1) A-III, B-I, C-IV, D-II
 (2) A-II, B-III, C-IV, D-I
 (3) A-IV, B-I, C-II, D-III
 (4) A-IV, B-II, C-I, D-III

90. For the following reaction sequence, choose the correct option

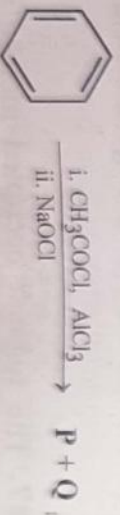

- (1) Both P and Q are carbonyl compounds.
 (2) If P is the sodium salt of a carboxylic acid, Q is a primary alcohol.
 (3) P and Q are aromatic compounds.
 (4) If P gives a carboxylic acid on acidification, Q gives a poisonous gas on exposure to air and light.

91. Given below are two statements :

Statement I : The class name Reptilia refers to creeping or crawling mode of locomotion.

Statement II : All organisms belonging to Reptilia have three chambered heart.

In the light of the above statements, choose the most appropriate answer from the options given below :

- (1) Statement I is incorrect but Statement II is correct
 (2) Both Statement I and Statement II are correct
 (3) Both Statement I and Statement II are incorrect
 (4) Statement I is correct but Statement II is incorrect

92. How many turns of Calvin cycle are required for the formation of three molecules of glucose ?

- (1) 18 (2) 6
 (3) 3 (4) 1

93. Photorespiration reaction catalyzed by RuBisCo is shown below :

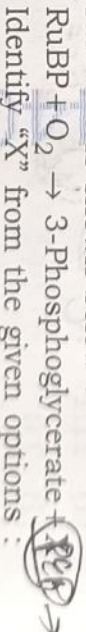

Identify "X" from the given options :

- (1) Malate
 (2) Phosphoenolpyruvate
 (3) 2-Phosphoglycolate
 (4) Oxaloacetate

94. Given below are two statements :

Statement I : In gymnosperms, the male and female gametophytes remain within the sporangia.

Statement II : In gymnosperms, seeds are not covered.

In the light of the above statements, choose the most appropriate answer from the options given below :

- (1) Statement I is incorrect but Statement II is correct
 (2) Both Statement I and Statement II are correct
 (3) Both Statement I and Statement II are incorrect
 (4) Statement I is correct but Statement II is incorrect

95. How many molecules of pyruvic acid are produced at the end of glycolysis from 206 molecules of glucose ?

- (1) 412 (2) 206
(3) 309 (4) 103

96. Match List-I with List-II.

List-I

List-II

- A. Fusion of protoplasts I. Meiosis
between gametes
B. Fusion of two nuclei II. Plasmogamy
C. Generation of haploid III. Karyogamy
spores

Choose the **correct** answer from the options given below :

- (1) A-I, B-III, C-II
(2) A-II, B-III, C-I
(3) A-II, B-I, C-III
(4) A-III, B-II, C-I

97. Mitochondrial inner membrane encloses _____.

- (1) aqueous humor
(2) matrix
(3) cytosol
(4) mucus

98. Phyllotaxy is the pattern of arrangement of _____.

- (1) sepals (2) leaves
(3) flowers (4) fruits

99. Mad cow disease is caused by _____.

- (1) *Mycoplasma* sp.
(2) prions
(3) viroids
(4) *Aspergillus* sp.

100. Cell theory was formulated by _____.

- (1) Antonie Von Leeuwenhoek
(2) Schleiden and Schwann
(3) Robert Brown
(4) Singer and Nicolson

101. Which of the following plant growth regulators promotes internode elongation prior to flowering in cabbage ?

- (1) Ethephon
(2) Abscisic acid
(3) Gibberellin
(4) Indole butyric acid

102. Which pigment has absorption peak at 700 nm in the photosynthetic reaction centre PS I (P700) ?

- (1) Carotenoids
(2) Chlorophyll b
(3) Chlorophyll a
(4) Xanthophylls

103. Sphenopsida class belongs to _____.

- (1) pteridophytes
(2) bryophytes
(3) angiosperms
(4) gymnosperms

104. Which of the following represents the correct sequence of arrangement of bones in the lower limb of humans ?

- (1) Femur-tarsal-patella-tibia
(2) Femur-tibia-patella-tarsal
(3) Patella-femur-tibia-tarsal
(4) Femur-patella-tibia-tarsal

105. Which of the following plant growth regulators is used as herbicide ?

- (1) Gibberellin
(2) 2,4-D
(3) Kinetin
(4) Abscisic acid

106. Genus represents _____.

- (1) a group of closely related families
(2) an individual plant or animal
(3) a population of plants and animals
(4) a group of closely related species

107. The plastid that stores xanthophyll is known as _____.
- (1) amyloplast
 - (2) chloroplast
 - (3) chromoplast
 - (4) aleuroplast

108. In water, frogs respire using _____.
- (1) trachea
 - (2) skin
 - (3) buccal cavity
 - (4) lungs

109. Which of the following is **not** a characteristic of chordates ?
- (1) Presence of post anal part (tail)
 - (2) Presence of notochord
 - (3) Central nervous system is dorsal
 - (4) Absence of gills

110. Smooth endoplasmic reticulum _____.
- (1) is a site for the synthesis of carbohydrates
 - (2) has ribosomes attached to its surface
 - (3) is the major site for the synthesis of lipids
 - (4) is actively involved in protein synthesis

111. Which of the following are characteristics of prokaryotic cells ?
- (a) Ribosomes are made of 50S and 30S subunits
 - (b) They can have plasmids
 - (c) They contain mesosome
 - (d) They have peroxisomes
- Choose the **correct** answer from the options given below :

- (1) (a), (b) and (c) only
- (2) (b) and (c) only
- (3) (a) and (c) only
- (4) (a), (c) and (d) only

112. Match List-I with List-II.

List-I

List-II

- | | |
|---|--|
| A. Cristae | I. Flat membrane sacs in stroma of chloroplast |
| B. Cisternae | II. Infoldings in mitochondria |
| C. Thylakoids | III. Cell membrane |
| D. Phospholipid IV. Disc shaped sacs in the Golgi apparatus | |

Choose the **correct** answer from the options given below :

- (1) A-IV, B-III, C-I, D-II
- (2) A-III, B-IV, C-I, D-II
- (3) A-II, B-IV, C-I, D-III
- (4) A-II, B-IV, C-III, D-I

113. Which of the following statements related to pituitary gland are **correct** ?

- (a) It is divided anatomically into adeno-hypophysis and neurohypophysis
 - (b) It secretes follicle stimulating hormone
 - (c) It secretes melanocyte stimulating hormone
 - (d) It does not secrete prolactin
- Choose the **correct** answer from the options given below :
- (1) (b) and (c) only
 - (2) (a) and (b) only
 - (3) (a), (b) and (c) only
 - (4) (c) and (d) only

114. Which of the following statements regarding photorespiration are correct ?

- (a) Do not occur in C₃ plants
- (b) CO₂ is consumed and O₂ is generated
- (c) Phosphoglycolate is formed
- (d) No synthesis of ATP and NADPH

Choose the **correct** answer from the options given below :

- (1) (a) and (b) only
- (2) (a) and (d) only
- (3) (c) and (d) only
- (4) (b) and (d) only

115. Which of the following statements is **incorrect** ?

- (1) Fibrinogen is produced from fibrin
- (2) Blood coagulates in response to an injury
- (3) Blood clot consists of fibrins
- (4) Fibrin is produced from fibrinogen

116. Arrange the following taxonomic categories in ascending order.

- | | |
|-------------|-------------|
| (a) Genus | (b) Class |
| (c) Order | (d) Phylum |
| (e) Family | (f) Kingdom |
| (g) Species | |

Choose the **correct** answer from the options given below :

- (1) (f), (c), (b), (g), (d), (e), (a)
- (2) (g), (a), (e), (c), (b), (d), (f)
- (3) (a), (c), (d), (g), (f), (b), (e)
- (4) (g), (c), (d), (b), (e), (a), (f)

117. Select the correct sequence of experiments that led to a gradual understanding of photosynthesis in green plants.

- (1) Production of glucose → role of air → release of oxygen → absorption spectra of chlorophyll a and b
- (2) Absorption spectra of chlorophyll a and b → production of glucose → release of oxygen → role of air
- (3) Role of air → release of oxygen → production of glucose → absorption spectra of chlorophyll a and b
- (4) Release of oxygen → production of glucose → absorption spectra of chlorophyll a and b → role of air

118. Match **List-I** with **List-II**.

- | | |
|-------------------|------------------------|
| List-I | List-II |
| A. Starch | I. Fights infection |
| B. Antibody | II. Energy storage |
| C. Concanavalin A | III. Glucose transport |
| D. Glut-4 | IV. Lectin |

Choose the **correct** answer from the options given below :

- (1) A-I, B-II, C-III, D-IV
- (2) A-I, B-II, C-IV, D-III
- (3) A-II, B-I, C-IV, D-III
- (4) A-II, B-I, C-III, D-IV

$C_2 = 7$
 $T_2 = 12$
 $L_2 = 5$
 $S_2 = 4$

119. The number of vertebrae in a human is

- (1) 206
- (2) 7
- (3) 12
- (4) 26

120. Endomembrane system includes

- (1) Golgi complex, chloroplast, peroxisomes and vacuole
- (2) endoplasmic reticulum, Golgi complex, lysosomes and vacuole
- (3) endoplasmic reticulum, chloroplast, peroxisomes and vacuole
- (4) mitochondria, chloroplast, peroxisomes and vacuole

121. Length of the stem at time 0 is 20 cm. The arithmetic growth rate is 30 cm per day. What is the length of the stem at the end of the 7th day ?

- (1) 460 cm
- (2) 50 cm
- (3) 170 cm
- (4) 230 cm

122. Match **List-I** with **List-II**.

- | | |
|---------------|----------------|
| List-I | List-II |
| A. Spherical | I. Vibrio |
| B. Rod | II. Cocci |
| C. Comma | III. Spirilla |
| D. Spirillum | IV. Bacilli |

Choose the **correct** answer from the options given below :

- (1) A-II, B-IV, C-I, D-III
- (2) A-I, B-III, C-II, D-IV
- (3) A-III, B-II, C-I, D-IV
- (4) A-II, B-I, C-IV, D-III

123. The number of action potentials generated by sino-arterial node (SAN) in a healthy human is _____ per minute.

- (1) 120 - 140
- (2) 28 - 30
- (3) 70 - 75
- (4) 100 - 110

124. Match List-I with List-II.

List-I List-II

- | | |
|-----------|---------------------|
| A. Family | I. Sapindales |
| B. Genus | II. Dicotyledonae |
| C. Class | III. Anacardiaceae |
| D. Phylum | IV. Angiospermae |
| E. Order | V. <i>Mangifera</i> |

Choose the **correct** answer from the options given below :

- (1) ~~A~~ A-III, B-V, C-II, D-IV, E-I
 (2) A-I, B-V, C-II, D-IV, E-III
 (3) ~~A~~ A-II, B-I, C-III, D-IV, E-V
 (4) ~~A~~ A-II, B-III, C-V, D-I, E-IV

125. Which of the following is **not** a part of human central neural system ?

- (1) ~~Pericardium~~ *Pericardium*
 (2) Arachnoid ✓
 (3) Dura mater ✓
 (4) Pia mater ✓

126. Given below are two statements :

Statement I : Chromosomes are fully condensed at the end of prophase I.

Statement II : Meiosis I resembles mitosis.

In the light of the above statements, choose the **most appropriate** answer from the options given below :

- (1) **Statement I** is incorrect, but **Statement II** is true
 (2) Both **Statement I** and **Statement II** are true
 (3) Both **Statement I** and **Statement II** are false
 (4) **Statement I** is correct, but **Statement II** is false

127. Match List-I with List-II.

List-I List-II

- | | |
|------------------------------|----------------------|
| A. Marginal placentation | I. Argemone |
| B. Axile placentation | II. Tomato |
| C. Parietal placentation | III. <i>Primrose</i> |
| D. Free central placentation | IV. <i>Pea</i> |

Choose the **correct** answer from the options given below :

- (1) A-IV, B-II, C-I, D-III
 (2) ~~A~~ A-II, B-IV, C-I, D-III
 (3) A-IV, B-II, C-III, D-I
 (4) A-IV, B-III, C-I, D-II

128. Symbiotic association between fungi and algae are called _____.

- (1) chrysophytes (2) lichens
 (3) sponges (4) ~~mycorrhiza~~

129. Which of the following is **not** a prokaryote ?

- (1) Fungi
 (2) Bacteria
 (3) ~~Blue green algae~~
 (4) Mycoplasma

130. Arrange the following elements in descending order of their contribution to percentage weight of the human body.

- (a) Oxygen ✓ (b) Carbon ✓
 (c) Hydrogen ✓ (d) Nitrogen ✓

Choose the **correct** answer from the options given below :

- (1) (b), (a), (c), (d)
 (2) ~~(a)~~ (a), (b), (c), (d)
 (3) (c), (a), (b), (d)
 (4) (b), (c), (d), (a)

131. Which one of the following statements is **incorrect** ?

- (1) β -cells of pancreas secrete insulin
 (2) α -cells of pancreas secrete glucagon
 (3) ~~α -cells of pancreas secrete insulin~~
 (4) Glucagon stimulates glycogenolysis

132. Which of the following are characteristic features of Solanaceae family ?

- (a) Flowers are bisexual and actinomorphic
- (b) Calyx have five sepals and are united
- (c) Androecium have five stamens and are epipetalous
- (d) Ovary is inferior

Choose the **correct** answer from the options given below :

- (1) (b), (c) and (d) only
- (2) (a), (b) and (c) only
- (3) (d) only
- (4) (a) and (b) only

133. Given below are two statements :

~~Statement I~~ : When any plane passing through the central axis of the body divides the organism into two identical halves, it is called radial symmetry. ~~(P)~~

~~Statement II~~ : In phylum Echinodermata, both adults and larvae are radially symmetrical.

In the light of the above statements, choose the **most appropriate** answer from the options given below :

- (1) ~~Statement I~~ is incorrect but ~~Statement II~~ is correct
- (2) Both ~~Statement I~~ and ~~Statement II~~ are correct
- (3) Both ~~Statement I~~ and ~~Statement II~~ are incorrect
- (4) ~~Statement I~~ is correct but ~~Statement II~~ is incorrect

134. The correct sequence of adult cell cycle phases is _____.

- (1) S-M-G2-G1
- (2) G1-G2-S-M
- (3) G1-M-G2-S
- (4) G1-S-G2-M

135. In frogs, the number of pairs of cranial nerves arising from the brain are _____.

- (1) 12
- (2) 6
- (3) 9
- (4) 10

136. Given below are two statements : one is labelled as **Assertion A** and the other is labelled as **Reason R**.

Assertion A : In recombinant DNA technology, lysozyme is used for disrupting bacterial cells while cellulase is for plant cells.

Reason R : Isolation of genetic material needs disruption of cells.

In the light of the above statements, choose the **most appropriate** answer from the options given below :

- (1) **A** is not correct but **R** is correct
- (2) Both **A** and **R** are correct and **R** is the correct explanation of **A**
- (3) Both **A** and **R** are correct but **R** is not the correct explanation of **A**
- (4) **A** is correct but **R** is not correct

137. The method of directly of injecting a sperm into ovum in assisted reproductive technology is called :

- (1) Embryo transfer (ET)
- (2) Gamete intra fallopian transfer (GIFT)
- (3) Zygote intra fallopian transfer (ZIFT)
- (4) Intra cytoplasmic sperm injection (ICSI)

138. Adaptive radiation in placental mammals and Australian Marsupials leading to similarity between distant species is an example of _____.

- (1) genetic drift
- (2) divergent evolution
- (3) convergent evolution
- (4) founder effect

139. Given below are two statements : one is labelled as **Assertion A** and the other is labelled as **Reason R**.

Assertion A : In an experiment, Mendel observed that the F1 progeny plants are all tall and none are dwarf.

Reason R : Stem height is a contrasting trait, with tall being dominant and dwarf being recessive.

In the light of the above statements, choose the **most appropriate** answer from the options given below :

- (1) **A** is not correct but **R** is correct
 (2) Both **A** and **R** are correct and **R** is the correct explanation of **A**
 (3) Both **A** and **R** are correct but **R** is not the correct explanation of **A**
 (4) **A** is correct but **R** is not correct

140. Arrange the following in descending order of number of species in the Amazonian rain forest.

- (a) Plants
 (b) Birds
 (c) Fishes
 (d) Invertebrates
 (e) Mammals

Choose the **correct** answer from the options given below :

- (1) (b) > (a) > (d) > (c) > (e)
 (2) (c) > (b) > (d) > (e) > (a)
 (3) (d) > (a) > (c) > (b) > (e)
 (4) (e) > (b) > (a) > (c) > (d)

141. Sponges exchange O_2 with CO_2 by

- (1) gills
 (2) simple diffusion over their entire body surfaces
 (3) moist cuticle (cuticle is not present)
 (4) tracheal tubes

142. For a person with blood group 'O', which of the following is **not** a possible combination of parents' blood group genotypes ?

- (1) Father : $I^A I^B$ and Mother : $I^A I^A$
 (2) Father : $I^A I^A$ and Mother : $I^B I^B$
 (3) Father : $I^A I^A$ and Mother : $I^A I^A$
 (4) Father : $I^B I^B$ and Mother : $I^B I^B$

143. Given below are two statements :
Statement I : Modern *Homo sapiens* arose in Australia and moved across continents.

Statement II : *Homo sapiens* arose around 75000 to 10000 years ago.

In the light of the above statements, choose the **most appropriate** answer from the options given below :

- (1) **Statement I** is incorrect but **Statement II** is correct
 (2) Both **Statement I** and **Statement II** are correct
 (3) Both **Statement I** and **Statement II** are incorrect
 (4) **Statement I** is correct but **Statement II** is incorrect

144. Which of the following is used as an effective sedative and painkiller for treating post-surgery patients ?

- (1) Anti-retroviral drugs
 (2) Interferon
 (3) Antibiotics
 (4) Morphine

145. Which of the following plant produces non-albuminous seeds ?

- (1) Pea
 (2) Wheat
 (3) Maize
 (4) Barley

146. Given below are two statements : one is labelled as **Assertion A** and the other is labelled as **Reason R**.

Assertion A : Abingdon tortoise in Galapagos islands became extinct within a decade after goats were introduced.

Reason R : Goats were more efficient at browsing than Abingdon tortoise.

In the light of the above statements, choose the **most appropriate** answer from the options given below :

- (1) **A** is not correct but **R** is correct
 (2) Both **A** and **R** are correct and **R** is the correct explanation of **A**
 (3) Both **A** and **R** are correct but **R** is not the correct explanation of **A**
 (4) **A** is correct but **R** is not correct

147. The covering of ovum at ovulation is _____

- (1) chorion
- (2) endometrium
- (3) zona radiata
- (4) zona pellucida

148. Which of the following is used as a clot buster ?

- (1) Statins
- (2) Streptokinase
- (3) Penicillin
- (4) Cyclosporin A

149. Which of the following structure is **not** a part of the male reproductive system ?

- (1) Infundibulum
- (2) Rete testis
- (3) Epididymis
- (4) Vasa efferentia

150. Given below are two statements :

Statement I : Ovulation is caused by LH surge leading to rupture of Graafian follicles.

Statement II : Graafian follicle remaining after ovulation transform into corpus luteum and secretes large amount of estrogen.

In the light of the above statements, choose the **most appropriate** answer from the options given below :

- (1) **Statement I** is incorrect but **Statement II** is correct
- (2) Both **Statement I** and **Statement II** are correct
- (3) Both **Statement I** and **Statement II** are incorrect
- (4) **Statement I** is correct but **Statement II** is incorrect

151. The opening between the right atrium and the right ventricle is guarded by _____

- (1) sino-atrial node
- (2) bicuspid valve
- (3) tricuspid valve
- (4) semilunar valve

152. Which of the following is **not** evidence for evolution ?

- (1) Divergent evolution of anatomical structures such as forelimbs
- (2) Convergent evolution of traits like wings of birds and butterflies
- (3) Paleontological evidence from fossil records
- (4) Embryological support for evolution as proposed by Ernst Haeckel

153. The inactive form of Bt toxin is converted to the active form in the insect gut _____.

- (1) by nucleases
- (2) due to alkaline pH
- (3) due to acidic pH
- (4) by proteases

154. Colostrum, secreted by mother during initial days of lactation, is abundant in _____.

- (1) IgD
- (2) IgG
- (3) IgM
- (4) IgA

155. Which of the following in female gametophyte of an angiosperm helps in guiding the pollen tube for fertilizing the eggs ?

- (1) Polar nucleus
- (2) Antipodals
- (3) Synergids
- (4) Central cells

156. Which of the following disease is **not** sexually transmitted ?

- (1) Genital warts
- (2) Syphilis
- (3) Tuberculosis
- (4) Gonorrhoea

157. Which of the following statements about lac-operon is **correct** ?

- (1) Galactose can act as an inducer of lac operon
- (2) Gene *i* is constitutively expressed
- (3) Lactose activates repressor to bind to the operator
- (4) Genes *i*, *z*, *y* and *a* share single common promoter

158. Match List-I with List-II.

List-I

List-II

- | | |
|-------------------|-----------------------------------|
| A. Transformation | I. Restriction enzyme |
| B. Cloning site | II. Transfer DNA to host bacteria |
| C. Selection | III. Replication |
| D. Ori | IV. Antibiotic |

Choose the **correct** answer from the options given below :

- (1) A-IV, B-I, C-III, D-II
 (2) A-II, B-I, C-IV, D-III
 (3) A-I, B-II, C-IV, D-III
 (4) A-III, B-IV, C-II, D-I

159. A population of diploid organisms is at Hardy-Weinberg equilibrium. If the frequency of allele A is 0.1, the frequency of AA is _____.

- (1) 0.99 (2) 0.01
 (3) 0.02 (4) 0.10

160. Sperm motility is due to _____.

- (1) muscular movement
 (2) flagellar movement
 (3) ciliary movement
 (4) amoeboid movement

161. Consider a population of 10 million cells. Given the per-capita birth rate of 0.002 (per unit time) and the per-capita death rate of 0.002 (per unit time), the expected number of cells after 10 generations is _____.

- (1) 100 million
 (2) 1 million
 (3) 5 million
 (4) 10 million

162. Given below are two statements : one is labelled as **Assertion A** and the other is labelled as **Reason R**.

Assertion A : Forelimbs of human and bats are homologous.

Reason R : Forelimbs of humans and bats have similar anatomical structure.

In the light of the above statements, choose the **most appropriate** answer from the options given below :

- (1) A is false but R is true
 (2) Both A and R are correct and R is the correct explanation of A
 (3) Both A and R are true, but R is not the correct explanation of A
 (4) A is true but R is false

163. Muscle contraction is initiated by a signal sent by the central nervous system by the release of _____.

- (1) cyclic adenine monophosphate
 (2) acetyl choline
 (3) acetyl coenzyme A
 (4) cyclic guanine monophosphate

164. Which of the following hormone is **not** secreted by human placenta ?

- (1) LH
 (2) hCG
 (3) Estrogen
 (4) Progesterone

165. Which of the following statements is **correct** about *Plasmodium* ?

- (1) Fertilization takes place in mosquito gut
 (2) Reproduces sexually in liver cells
 (3) Reproduces sexually in RBCs
 (4) Gametocytes develop in mosquito gut

166. Which of the following are primary consumers in a food chain ?

- (1) Carnivores
 (2) Parasites
 (3) Predators
 (4) Herbivores

167. Which of the following statements about the reabsorption process in Henle's loop are correct ?

- (a) The descending limb of Henle's loop is permeable to water but almost impermeable to electrolytes.
 (b) Urine gets concentrated in Henle's loop.
 (c) Reabsorption of Na^+ and water takes place in Henle's loop.
 (d) Active or passive transport of electrolytes occurs in the ascending limb of Henle's loop.

Choose the **correct** answer from the options given below :

- (1) (a), (b) and (d) only
 (2) (a) and (b) only
 (3) (b), (c) and (d) only
 (4) (a), (b) and (c) only

168. Given below are two statements : one is labelled as **Assertion A** and the other is labelled as **Reason R**.

Assertion A : The logistic growth model of populations is considered more realistic than the exponential growth model.

Reason R : Resources are finite.

In the light of the above statements, choose the **most appropriate** answer from the options given below :

- (1) A is not correct but R is correct
 (2) Both A and R are correct and R is the correct explanation of A
 (3) Both A and R are correct but R is not the correct explanation of A
 (4) A is correct but R is not correct

169. Which of the following is the **correct** order of arrangement of vertebrate column from the head to toe ?

- (1) Cervical vertebra, thoracic vertebra, lumbar vertebra, sacrum
 (2) Cervical vertebra, thoracic vertebra, lumbar vertebra, sacrum
 (3) Sacrum, lumbar vertebra, thoracic vertebra, cervical vertebra
 (4) Cervical vertebra, lumbar vertebra, thoracic vertebra, sacrum

170. Match List-I with List-II.

List-I

List-II

- A. Both species are harmed \rightarrow Predation
 B. One species is harmed and the other is benefited \rightarrow Mutualism
 C. Both species are benefited \rightarrow Competition
 D. One is benefited while the other has no effect \rightarrow IV. Commensalism

Choose the **correct** answer from the options given below :

- (1) A-III, B-I, C-II, D-IV
 (2) A-III, B-IV, C-II, D-I
 (3) A-I, B-II, C-III, D-IV
 (4) A-II, B-I, C-IV, D-III

171. If the diploid chromosome number of typical angiosperm is 36, what would be the chromosome number in its endosperm ?

- (1) 72 (2) 18
 (3) 36 (4) 54

172. Which of the following enzymes synthesizes precursor mRNA ?

- (1) DNA polymerase
 (2) RNA polymerase I
 (3) RNA polymerase II
 (4) RNA polymerase III

173. Given below are two statements :

Statement I :

Plasmids are autonomously replicating DNA.

Statement II :

Plasmids are extrachromosomal DNA.

In the light of the above statements, choose the **most appropriate** answer from the options given below :

- (1) **Statement I** is incorrect but **Statement II** is correct
 (2) Both **Statement I** and **Statement II** are correct
 (3) Both **Statement I** and **Statement II** are incorrect
 (4) **Statement I** is correct but **Statement II** is incorrect

174. How many theca are present in each lobe of a typical bilobed angiosperm anther ?

- (1) 12
(2) 2
(3) 6
(4) 8

175. Natural selection can lead to

- (a) stabilisation
(b) genetic drift
(c) directional change
(d) disruption

Choose the **correct** answer from the options given below :

- (1) (a) and (c) only
(2) (a) only
(3) (a), (c) and (d) only
(4) (a), (b), (c) and (d)

176. Which of the following statements are **correct** ?

- (a) Energy flow from producers to consumers is unidirectional
(b) Energy pyramid can never be inverted
(c) Transfer of energy follows the 1% law

Choose the **correct** answer from the options given below :

- (1) (b) and (c) only
(2) (a), (b) and (c)
(3) (a) and (b) only
(4) (a) and (c) only

177. Match **List-I** with **List-II**.

List-I

List-II

- A. Excess growth hormone
B. Luteinizing hormone
C. Vasopressin
D. Oxytocin
- I. Reabsorption of water and electrolytes in kidney
II. Contraction of uterus during child birth
III. Acromegaly
IV. Ovulation

Choose the **correct** answer from the options given below :

- (1) A-IV, B-III, C-I, D-II
(2) A-III, B-IV, C-II, D-I
(3) A-III, B-IV, C-I, D-II
(4) A-II, B-IV, C-I, D-III

178. Which of the following are secondary lymphoid organs ?

- (a) Bone marrow
(b) Tonsils
(c) Spleen
(d) Thymus

Choose the **correct** answer from the options given below :

- (1) (a) and (d) only
(2) (a) and (b) only
(3) (b) and (c) only
(4) (b) and (d) only

179. During PCR, primers bind to the DNA strands in the _____ step.

- (1) ligation
(2) denaturation
(3) extension
(4) annealing

180. Given below are two statements :

Statement I : Down's syndrome is caused by the absence of one of the X-chromosomes. *pen*

Statement II : Turner's syndrome is caused by the presence of an additional copy of the chromosomes.

In the light of the above statements, choose the **correct** answer from the options given below :

- (1) **Statement I** is incorrect but **Statement II** is correct
(2) Both **Statement I** and **Statement II** are correct
(3) Both **Statement I** and **Statement II** are incorrect
(4) **Statement I** is correct but **Statement II** is incorrect



Your Entire NEET Counseling Journey, in Just One App !

Trusted by **100K+** Medicos

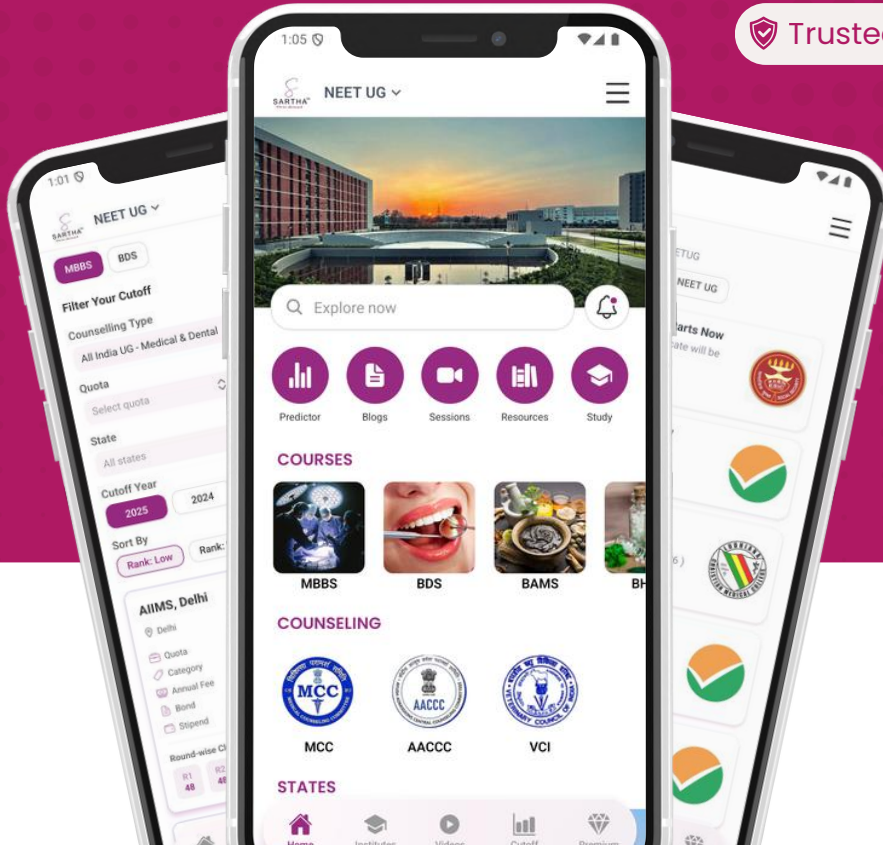

- ONE-O-ONE COUNSELING
- CHOICE & FORM FILLING
- COLLEGE REVIEWS
- COLLEGES COMPARISON
- LIVE SESSIONS

- COLLEGE PREDICTION
- PREFERENCE LIST
- CUTOFF/FEE/ BOND DATA
- SCHOLARSHIP GUIDANCE
- NOTIFICATION & UPDATES

Download **SARTHA** App

OUR COUNSELING SERVICES

- MBBS Counseling
- BDS Counseling
- AYUSH Counseling
- BVSC Counseling
- Abroad MBBS Counseling

Scan to Explore Now

GET IT ON Google Play

Download on the App Store

- EXPERT COUNSELORS Experienced & Dedicated Guidance
- 100% VERIFIED INFORMATION Authentic & Updated
- PERSONALIZED SUPPORT Always With You