

## Serrage bas 1

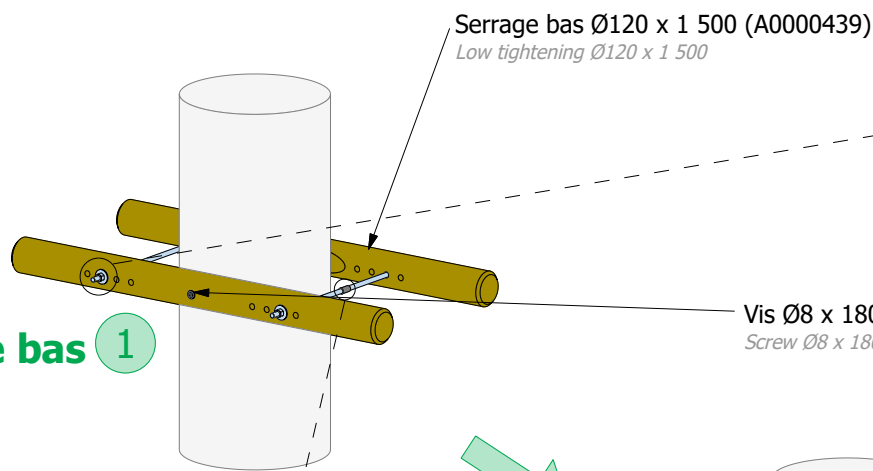

Pour les arbres de très gros diamètre :

- Entretoises cylindriques Ø16 mm
- Tiges filetées M16 x 1 000 mm

For very large diameter trees :

- Cylindrical spacers Ø16 mm
- Threaded rods M16 x 1 000 mm

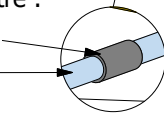

## Serrage haut 2

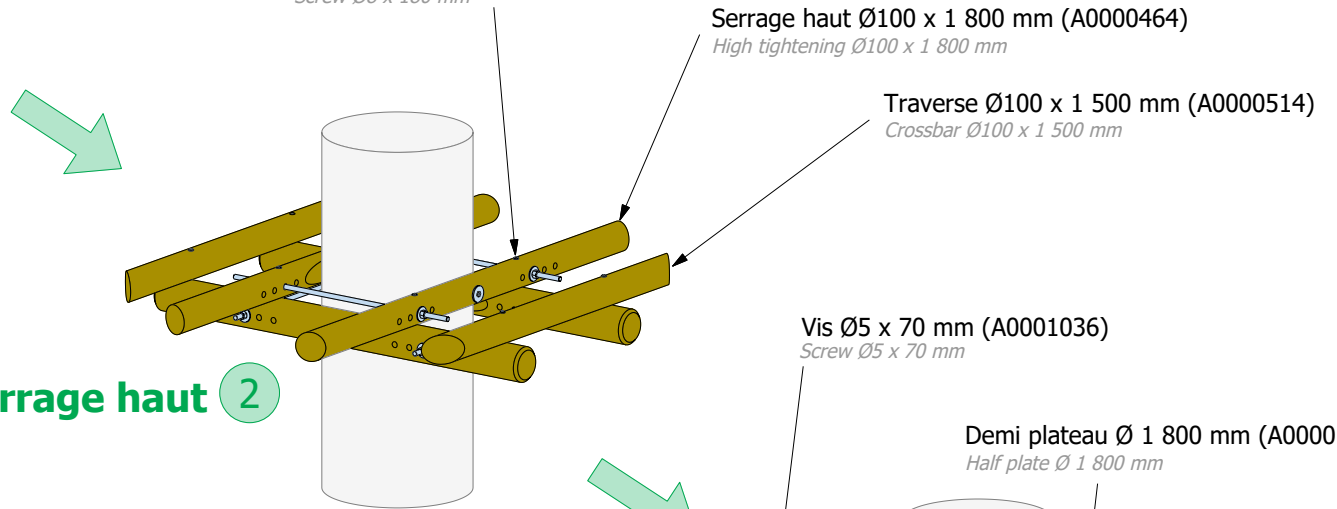

## Plancher 3

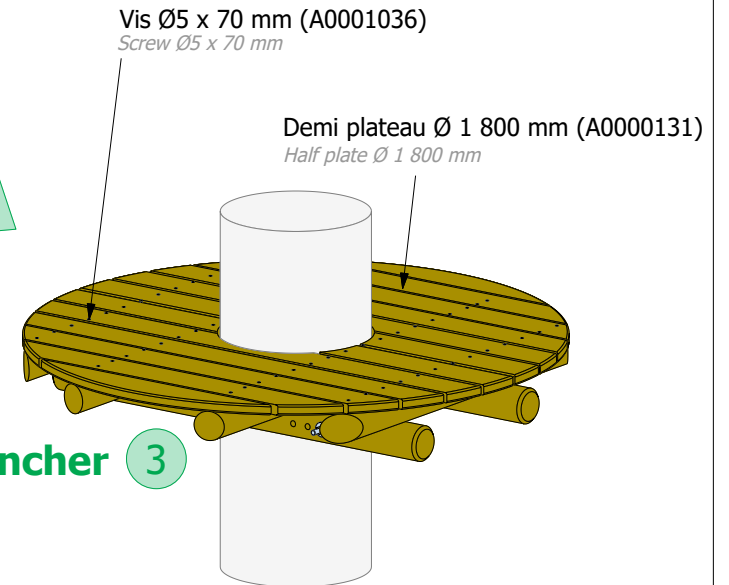

### Le conseil du pro

Professional tips

Différents perçages dans les serrages du haut et du bas pour s'adapter au diamètre des arbres  
Possibilité d'excentrer la plateforme selon le sens de passage de la ligne de vie ou pour les arbres penchés

Different holes in the upper and lower clamps to adapt to the diameter of the trees  
Possibility to offset the platform according to the direction of the lifeline or for leaning trees

Suggestion de montage Construction suggestion

Plateforme serrage Ø1800  
clamping platform Ø1800

