

prostoria

prostoria

CONTENT / SOMMAIRE

- 05 **prostoria** - Innovation as social responsibility
prostoria - L'innovation au service de la responsabilité sociale
- 18 CHAIRS / EASY CHAIRS / TABLES / SMALL TABLES
CHAISES / FAUTEUILS / TABLES / TABLES BASSES
- 92 SOFAS / SOFABEDS / ACCESSORIES
CANAPÉS / CANAPÉS CONVERTIBLES / ACCESSOIRES
- 216 BIOGRAPHY
BIOGRAPHIE

**prostoría - Innovation
as social responsibility
/ L'innovation au service de
la responsabilité sociale**

MAROJE MRDULJAŠ



We tend to perceive furniture as something abstract, created on designers' desks and then produced, branded and placed on the market by companies with different statuses and reputations. In fact, relations inside the contemporary globalized furniture industry are becoming more and more fragmented with less and less opportunity for complete dedication to synergies and collaborations... **prostoria**, as a young company whose catalogue already comprises some new icons such as the *Polygon* armchair and the *Revolve* transformable sofa, stands as an example of a different and more traditional approach based on the evolution from the local givenness and logical clustering of all actors involved in the production process.



POLYGON

Nous avons tendance à percevoir le meuble comme une chose abstraite conçue sur la planche à dessin d'un designer, puis produite, marquée et mise sur le marché par des sociétés de réputation et standing différents. Dans la réalité, les relations dans l'industrie mondiale du mobilier moderne deviennent de plus en plus fragmentées avec de moins en moins de possibilités de se consacrer entièrement aux synergies et collaborations... **prostoria**, en tant que jeune société dont le catalogue comporte déjà quelques nouvelles icônes comme le fauteuil *Polygon* et le canapé transformable *Revolve*, est l'exemple d'une approche différente et plus traditionnelle basée sur l'évolution de la volonté locale et l'agglomération logique de tous les acteurs appliqués lors du processus de production.

Rapid development of **prostoria**, formerly known as *Kvadra*, a company which has come a long way, from 'starting from zero' to positioning itself as the leader and promoter of new ideas in only a few years time, is a story about the reintroduction of continuity both in Croatia and Central Europe, a region with vital but insufficiently recognized design scene and remarkable tradition and knowledge of the furniture industry. Those elements served as latent potentials that provided grounds for continuation and had to be activated. Since the beginning, **prostoria** has been developing an integrative approach, functioning as a collaboration platform that nourishes and stimulates continuous exchange of knowledge and experience between all the actors participating in the production of furniture.



REVOLVE

Le développement rapide de **prostoria**, connue initialement sous le nom de *Kvadra*, une société qui s'est élevée à la position de leader et promoteur d'idées novatrices en seulement quelques années, est l'histoire de la réintroduction de la continuité aussi bien en Croatie qu'en Europe centrale, une région avec un vivier de talents dans le domaine du design pas assez connu et une tradition et un savoir faire remarquable de l'industrie du mobilier. Ce potentiel dormant avait besoin d'être réactivé. Depuis le début, **prostoria** a développé le principe de partage, fonctionnant comme une plateforme d'échange nourrissant et stimulant l'échange permanent entre les différents acteurs de production du mobilier.





A dynamic workshop ambience has been created offering opportunities mainly to young designers to explore their ideas in excellent conditions and bring them to the highest level of design, functionality and technological artisanship. Many products have been developed over longer periods of time surpassing a number of iterations until reaching their final form, which would be impossible without the adequate support combining the contemporary technology and meticulous craftsmanship and handwork of the highest quality. Predominantly local materials are used, especially solid wood, and most of the production takes place within the company itself.



Une ambiance dynamique dans un esprit workshop a été créée offrant des opportunités aux jeunes designers afin d'explorer leurs idées dans d'excellentes conditions et de les amener au plus haut niveau du design, de fonctionnalité et de technicité artisanale. Grand nombre de produits ont été élaborés sur de longues périodes en passant par plusieurs versions avant la forme finale, ce qui aurait été impossible sans le soutien combiné des techniques modernes, de l'excellent savoir faire local et l'héritage d'un artisanat de la plus haute qualité. On utilise prioritairement des matériaux locaux, notamment le bois massif, et la plus grande partie de la collection est produite sur place dans nos locaux.

RHOMB

While the company's catalogue also offers furniture based on already proven models, **prostoria** shows strategic and even passionate dedication to research-based design, convinced that authenticity has its place on the market but presents a special challenge in the times when it seems almost impossible to create truly innovative and fresh concepts.



Même si le catalogue offre également des modèles ayant fait leur preuve, **prostoria** démontre une stratégie et même un dévouement passionné au design basé sur la recherche, convaincu que l'authenticité a sa place sur le marché mais se met au défi, paraissant pourtant impossible, de créer des concepts innovants et frais.

OBLIQUE





For that reason, **prostor**'s social responsibility and specific position have to be observed as a contribution to the evolution of design and readiness to take the risk in order to reach new values for the benefit of users and the culture. Thus, **prostor** stands as a distinct project inside of which designers grow together with the company on the grounds of mutual trust and shared goals. This is why designers and their creations have been given the leading role in this catalogue...



3ANGLE

Pour cette raison, la prise de position et la responsabilité sociale de **prostor** peuvent être observées comme une contribution à l'évolution du design et de la volonté de prendre des risques afin d'atteindre des valeurs nouvelles au service de l'utilisateur et de la culture. De ce fait, **prostor** se démarque comme un projet marquant dans lequel designers et société grandissent ensemble sur une base de confiance mutuelle et d'objectifs partagés. C'est pour cette raison que les designers ainsi que leurs créations ont le premier rôle dans ce catalogue...

18

6044

13. 10. 12

ZADNA

PRIF

ZADNA

2017

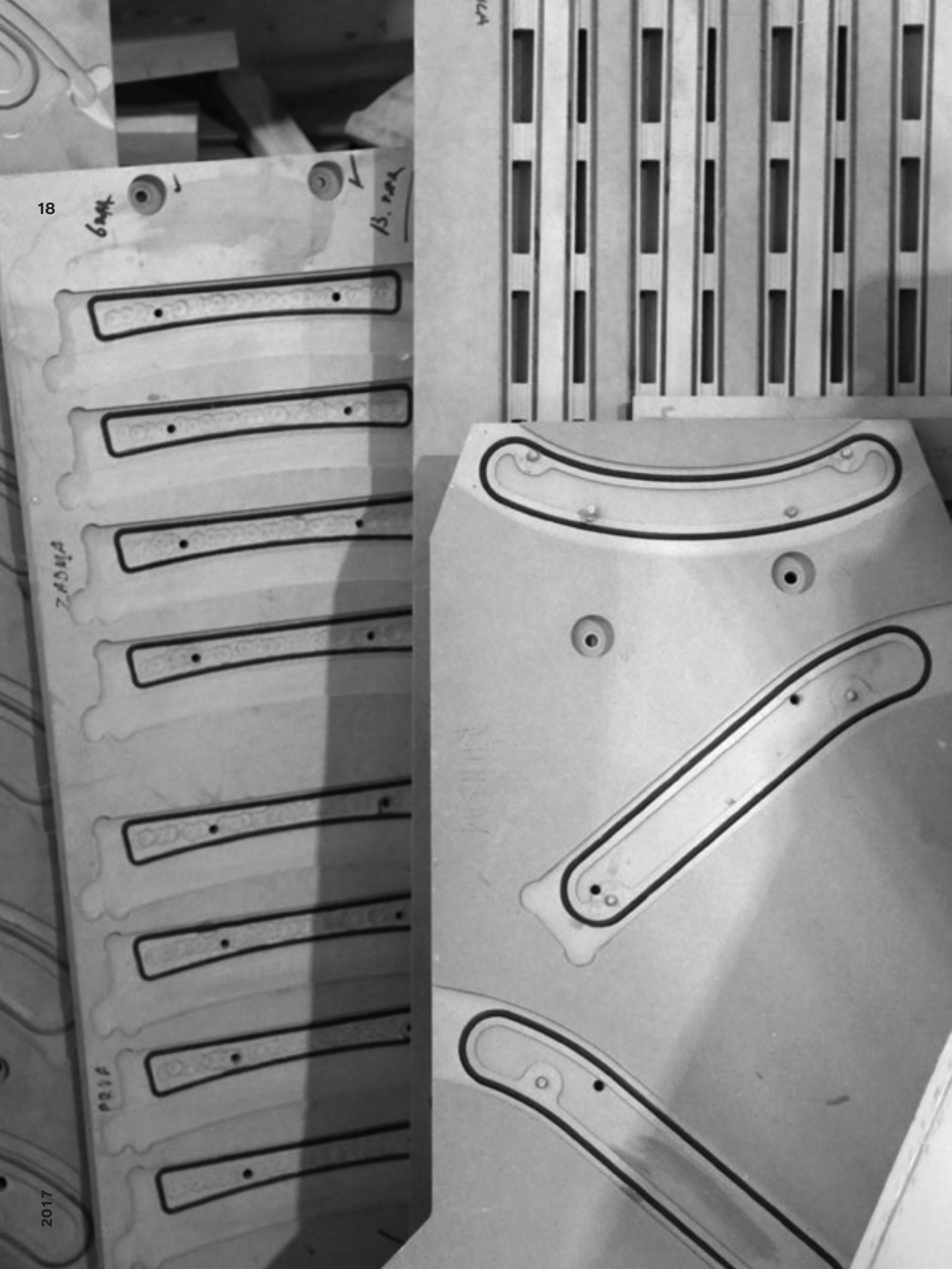



POLYGON 20



RHOMB 32



MONK 44

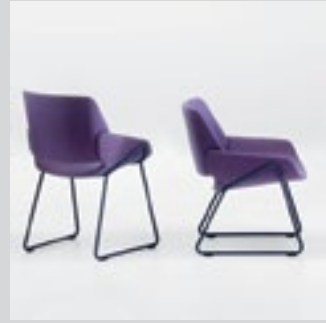

OBLIQUE 58

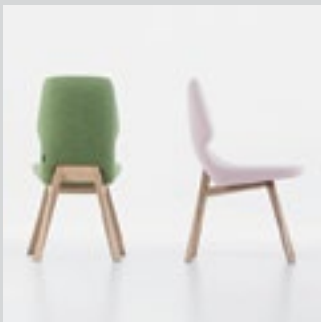

DOBRA 72



STRAIN 80



POLYGON

DESIGN: NUMEN/FOR USE



Ever since we first began to engage with design, we were fascinated with the standard modernist typology of chairs with modest dimensions that meet all functional parameters, without burdening the space with their bulkiness. We have explored a series of alternatives that are in line with these values, but also offer a new formal approach. *Polygon* retains all traditional elements of a modernist chair, but deconstructs them, creating new relations between them. The form of the bent steel bars of the structure, the seat and the backrest are coordinated via a triangular geometry. The composition of the triangle is accentuated when viewed from the side, but once the observer begins to move, these forms transform into hexagons and more complex polygons. We have continued to develop *Polygon* in close cooperation with **prostoria**, and have launched a new version of the chair that retains all features of the original design, but in an improved form. The resulting product has a somewhat defamiliarizing effect, seeming both familiar and distinctly contemporary.

Lorsque nous nous sommes engagés dans le design, nous étions fascinés par la typologie standard moderniste des chaises à modestes dimensions regroupant tous les paramètres de fonctionnalité, sans encombrer l'espace. Nous avons exploré une série d'alternatives dans la lignée de ces critères, mais offrant également une approche d'une nouvelle forme. *Polygon* garde les éléments traditionnels d'un fauteuil moderne, mais crée une toute autre relation entre eux en les déstructurant. La forme de la structure en barres d'acier pliées, l'assise et le dossier sont coordonnées selon une géométrie triangulaire. Vue de profil, la composition du triangle est mise en avant, mais lorsque l'observateur se déplace, ces formes se transforment en hexagones et polygones complexes. Nous avons continué à développer *Polygon* avec **prostoria** et nous avons lancé une nouvelle version ayant les mêmes caractéristiques que le design d'origine mais avec une forme améliorée. Le résultat a un effet déroutant, à la fois familier et résolument contemporain.



ARMCHAIR / FABRIC
CANVAS, STRUCTURE
METAL COATED,
ARMRESTS ASHWOOD
FAUTEUIL / TISSUS CANVAS,
STRUCTURE MÉTAL LAQUÉ,
ACCOUDOIRS FRÈNE





***Polygon* retains all traditional elements of a modernist chair, but deconstructs them, creating new relations between them. The resulting product has a somewhat defamiliarizing effect, seeming both familiar and distinctly contemporary.**

Polygon garde les éléments traditionnels d'une chaise moderne, mais crée une toute autre relation entre eux en les déstructurant. Le résultat a un effet déroutant, à la fois familier et résolument contemporain.

NUMEN/FOR USE



ARMCHAIR / FABRIC
CANVAS, STRUCTURE
BLACK CHROME,
ARMRESTS WALNUT
FAUTEUIL / TISSUS
CANVAS, STRUCTURE
CHROMÉE NOIR,
ACCOUDOIRS NOYER

ARMCHAIR / FABRIC
CANVAS, STRUCTURE
COPPER, ARMRESTS
FAUTEUIL / TISSUS
CANVAS, STRUCTURE
CUIVRE, ACCOUDOIRS
FRÈNE





Microsoft Executive Lounge, Vienna, Austria / Photo: Paul Ott



Restaurant Tatal Madrid, Spain / Project: Ilmiodesign, Andrea Spada & Michele Corbani / Photo: Uxio Davila

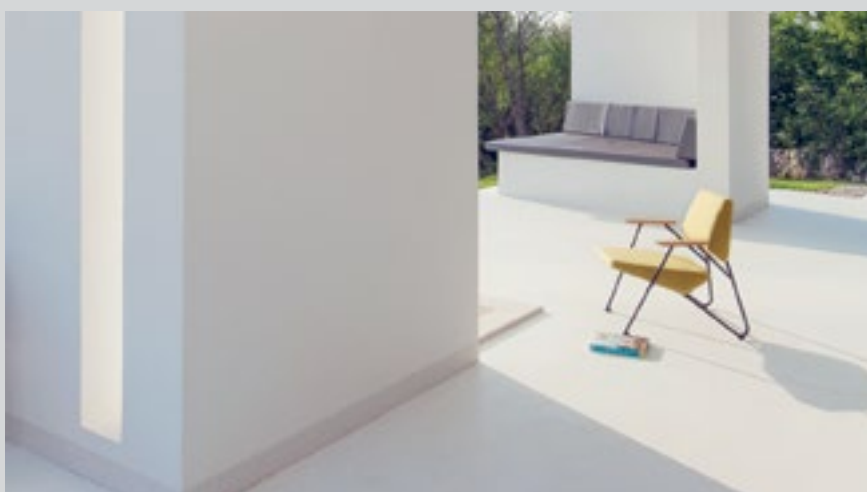

Villa The One, Kozljak, Istria, Croatia / Project: Denis & Lana Galić / Photo: Level52



ARMCHAIR / FABRIC
HALLINGDAL, STRUCTURE
METAL COATED,
ARMRESTS WALLNUT
FAUTEUIL / TISSUS HALLINGDAL,
STRUCTURE MÉTAL LAQUE,
ACCOUDOIRS NOYER

SMALL TABLE / LEGS
METAL COATED BLACK,
TABLE TOP FENIX NTM
TABLE BASSE / PIÉTEMENT
MÉTAL LAQUÉ NOIR,
PLATEAU FENIX NTM





POLYGON

ARMCHAIR / FAUTEUIL

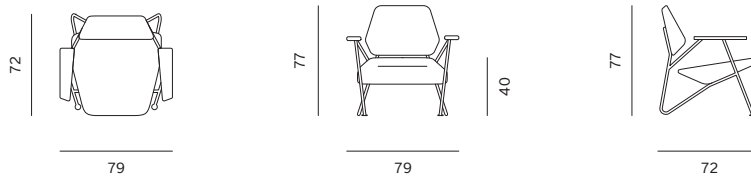

SMALL TABLE / TABLE BASSE

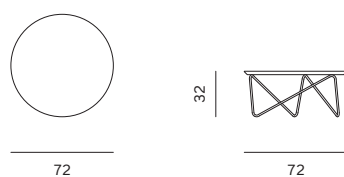

INTERIOR INNOVATION AWARD 2014 WINNER
GERMAN DESIGN AWARD 2015 WINNER

RHOMB



As a company, **prostoria** is oriented to the production in solid wood, which has resulted in the creation of the *Rhomb* chair, my first project realized in that noble material. Our intention was to design a chair with a distinguishing identity combined with accentuated comfortableness. For that reason, our design includes a number of small but decisive shifts in geometry and ergonomics that have been meticulously researched in the course of the project development. The *Rhomb* is somewhat wider than a common chair while its backrest organically continues into prolonged armrests. This allows for various, more relaxed seating positions and feasting becomes a hedonic act. The chair's organic shape is in opposition with the contemporary rhomboid geometry found in the cross section of the backrest and legs. Tactile and visual qualities of solid wood are accentuated owing to the combination of the state-of-the-art technology and sophisticated manual processing.

Un des engagements de **prostoria** est de fabriquer avec du bois massif, ce qui a donné naissance à la chaise *Rhomb*, mon premier projet en cette noble matière. Notre intention était de créer une chaise avec une identité forte tout en ayant un confort accru. Pour cette raison, notre design comprend de minimes mais incontournables changements de géométrie et d'ergonomie rendus possible grâce à des recherches poussées tout au long du développement du projet. La chaise *Rhomb* est un peu plus large qu'une chaise classique avec un dossier qui se prolonge en accoudoir de façon organique. Ceci permet des positions variables et plus détendues et fait qu'un simple diner devient un acte hédoniste. La forme organique de la chaise est en opposition avec la géométrie rhomboïde contemporaine retrouvée au niveau du croisement du dossier et du piétement. Les qualités tactiles et visuelles du bois massif sont sublimées par la combinaison d'une technologie de pointe et d'une transformation manuelle sophistiquée.



The *Rhomb* is somewhat wider than a common chair while its backrest organically continues into prolonged armrests. This allows for various, more relaxed seating positions and feasting becomes a hedonic act.

La chaise *Rhomb* est un peu plus large qu'une chaise classique avec un dossier qui se prolonge en accoudoir de façon organique. Ceci permet des positions variables et plus détendues et fait qu'un simple diner devient un acte hédoniste.

SIMON MORASI PIPERČIĆ



CHAIR / OAK BLACK
CHAISE / CHÊNE NOIR

CHAIR / DARK RED
CHAISE / NOIR ROUGE

CHAIR / WALNUT
CHAISE / NOYER

CHAIR / OAK NATURE
CHAISE / CHÊNE NATUREL

CHAIR / OAK LIGHT
CHAISE / CHÊNE CLAIR





CHAIR / OAK NATURE
CHAISE / CHÊNE NATUREL

RHOMB













RHOMB

CHAIR / CHAISE

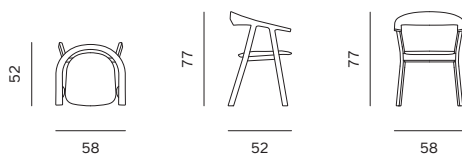
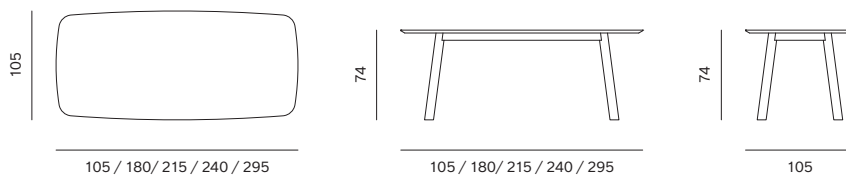

TABLE / TABLE



GERMAN DESIGN
AWARD 2017 WINNER

MONK

DESIGN: GRUPA



The *Monk* collection brings together the regional modernist tradition and contemporary design. Originally, the chair and armchair were designed for the renovation of the architectural icon – the Palace Hotel in Dubrovnik. At the same time, they were homage to the very popular *Lupina* chair, a classic designed by Niko Kralj. This simple idea is reduced to finding harmony in joining two bended platforms: one for the backrest and the other expanding into the armrest. This results in an upholstered shell mounted on various types of legs – higher ones for the chair and lower ones for the armchair. The name for this collection is a figurative association that simultaneously follows the modernist ethics that inspired the team of designers: it seems as if an old monk dressed in modest cotton clothes decided to sit in an unpretentious wooden chair. The two *Monks*, a chair and an armchair, fuse the everyday life filled with *work* and *contemplation*. The collection is supplemented with low tables, a dining room table and a bar stool.

La collection *Monk* est la fusion entre la tradition moderne régionale et le design contemporain. A l'origine, la chaise et le fauteuil étaient désignés pour la rénovation d'une icône de l'architecture, le Palace Hotel à Dubrovnik. Les assises étaient également un hommage à la chaise populaire *Lupina*, un classique créé par Niko Kralj. L'idée était de trouver l'harmonie au niveau de la jonction des deux éléments arrondis, en premier l'assise se développant en accoudoir et en second le dossier. Ceci s'exprime par deux coques rembourrées et montées sur des piétements variés, plus hauts pour la chaise et plus bas pour le fauteuil. Le nom de la collection reflète de façon figurative l'association d'idées qu'a inspiré l'équipe des designers : « comme si un vieux moine, en habit de coton modeste décida de s'asseoir sur une chaise de bois sans prétention ». Au quotidien, les deux *Monk*, chaise et fauteuil, inviteront tout autant au *travail* qu'à la *contemplation*. La collection est complétée par des tables basses, une table à manger et un tabouret haut.



It seems as if an old monk dressed in modest cotton clothes decided to sit in an unpretentious wooden chair. The two *Monks*, a chair and an armchair, fuse the everyday life filled with *work* and *contemplation*.

Comme si un vieux moine, en habit de coton modeste décida de s'asseoir sur une chaise de bois sans prétention ». Au quotidien, les deux *Monk*, chaise et fauteuil, inviteront tout autant au *travail* qu'à la *contemplation*.

GRUPA







CHAIR / FABRIC
CANVAS, METAL
LEGS 5003
CHAISE / TISSUS
CANVAS, PIÉTEMENT
MÉTAL 5003

ARMCHAIR / FABRIC
CANVAS, METAL
LEGS 5003
FAUTEUIL / TISSUS
CANVAS, PIÉTEMENT
MÉTAL 5003



CHAIR / FABRIC CANVAS,
METAL SLED BASE 5003
CHAISE / TISSUS CANVAS,
PIÉTEMENT LUGE 5003



ARMCHAIR / FABRIC
CANVAS, METAL SLED
BASE 5003
FAUTEUIL / TISSUS
CANVAS, PIÉTEMENT
LUGE 5003



CHAIR / FABRIC
CANVAS, LEGS OAK
NATURE
CHAISE / TISSUS
CANVAS, PIÉTEMENT
CHÊNE NATURE



Wooden House, Krk, Croatia / Project: Idis Turato / Photo: Bosnić+Dorotić



Meizai, Australia
Photo: Bek Sheppard

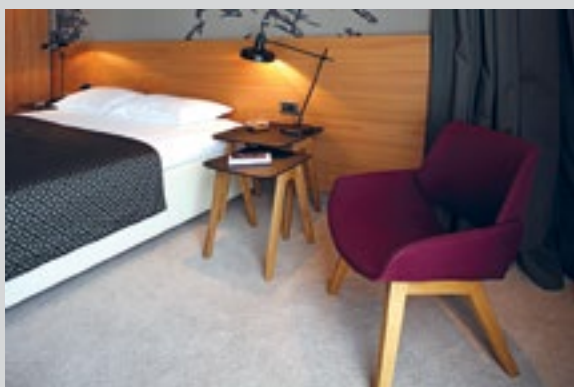
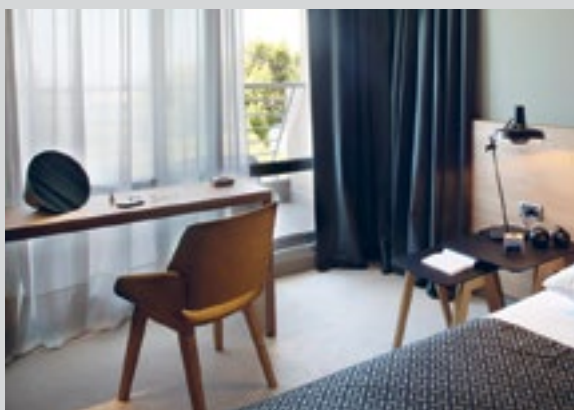

Hotel Palace, Dubrovnik, Croatia /
Project: 3LHD / Photo: Damir Fabijanić

CHAIR / FABRIC
CANVAS, LEGS OAK
LIGHT CHAISE / TISSUS
CANVAS, PIÉTEMENT
CHÊNE CLAIR



TABLE / OAK NATURE
TABLE / CHÊNE NATUREL
240 x 100 CM



TABLE / OAK NATURE
TABLE / CHÊNE NATUREL
100 x 100 CM

TABLE / OAK NATURE
TABLE / CHÊNE NATUREL
180X100 CM

CHAIR / FABRIC
CANVAS, LEGS METAL
SLED BASE 9002
CHAISE / TISSUS
CANVAS, PIÈTEMENT
MÉTAL LUGE 9002

CHAIR / FABRIC
CANVAS, LEGS
METAL 7022
CHAISE / TISSUS
CANVAS, PIÈTEMENT
MÉTAL 7022



ARMCHAIR /
FABRIC CANVAS,
LEGS OAK LIGHT
FAUTEUIL / TISSUS
CANVAS, PIÈTEMENT
CHÊNE CLAIR

57

MONK



prostoría

MONK

58

MONK

CHAIR / CHAISE

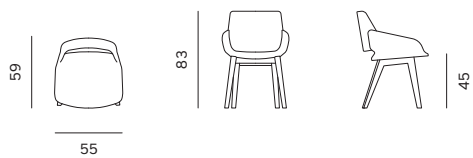

ARMCHAIR / FAUTEUIL

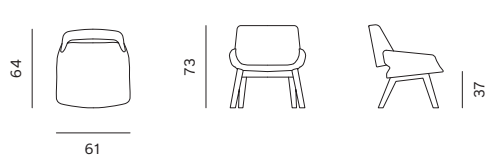

CHAIR SLED BASE / CHAISE LUGE

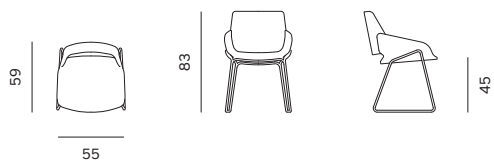

ARMCHAIR SLED BASE / FAUTEUIL LUGE

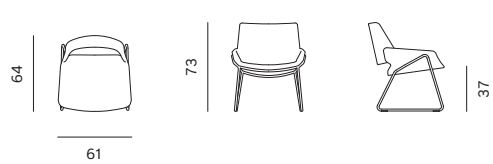

CHAIR METAL LEGS / CHAISE PIÉTEMENT MÉTAL



ARMCHAIR METAL LEGS / FAUTEUIL PIÉTEMENT MÉTAL

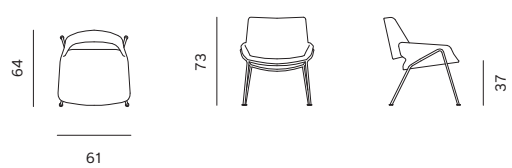

2017

SMALL TABLE MIDI / TABLE BASSE MIDI

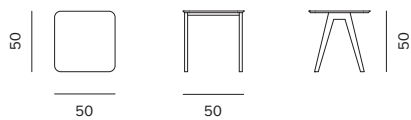

SMALL TABLE MINI / TABLE BASSE MINI

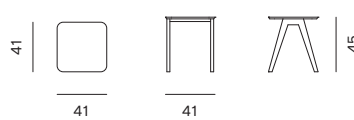
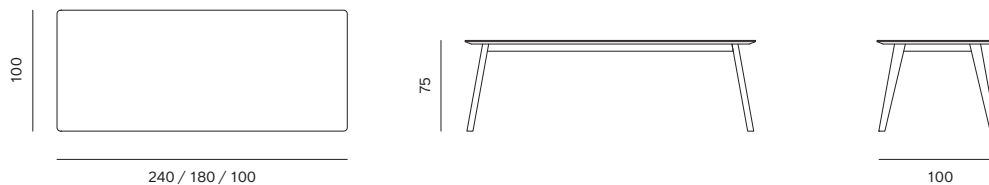
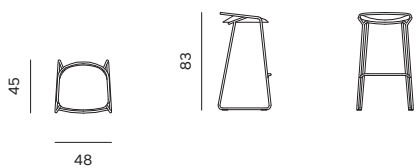

TABLE / TABLE



BAR STOOL / TABOURET DE BAR



OBLIQUE



When designing the *Oblique* family of products, we wanted to ensure a quality sitting experience for the user in a real soft armchair, but within minimal dimensions. It is these requirements that have created the recognizable profile of this set of chairs. The profile underlines two triangular prisms. They ensure the greatest thickness of the foam on the major points of support for the body when sitting: the back side of the seat and the lumbar zone of the backrest. The narrowed plane where the volume from the seat blends into the backrest improves the ergonomics, but also allows for the elasticity of the backrest. The top of the legs has a rectangular cross-section, but becomes increasingly thin towards the bottom, turning ultimately into a triangular base. This way, we have reduced the robustness of the wooden profiles of the structure and have given the design a geometric expressive and contemporary character. We have perfected the products through time, offering, in addition to the wooden leg structure, an alternative metal version that also includes an armrest. The *Oblique* family also comprises a larger table and smaller coffee tables.

Lorsque nous avons créé la ligne de produits *Oblique*, nous voulions assurer l'expérience d'un confort d'assise de qualité dans un fauteuil moelleux mais avec un encombrement minimum. Ce sont ces critères qui ont été à l'origine de cet ensemble d'assises reconnaissables. Le profil souligne deux prismes triangulaires. Ils assurent l'épaisseur maximale au niveau des points d'appui du corps; l'arrière de l'assise ainsi que la partie lombaire du dos. La partie étroite, où le volume de l'assise se courbe dans le dossier, améliore l'ergonomie mais apporte également de la souplesse au dossier. Le haut du piétement forme un support rectangulaire à section carrée mais les pieds s'affinent par la suite vers le bas pour finir en section triangulaire à la base. De cette façon, nous avons réduit le côté robuste des structures en bois massif habituelles, pour laisser la place à un design à géométrie expressive et à caractère contemporain. Nous avons perfectionné et fait évoluer le produit au fil du temps proposant, en plus du piétement en bois massif, une version piétement métal qui comprend également un accoudoir. La ligne *Oblique* se complète par une table à manger et des tables basses.



TABLE / LEGS OAK
NATURE, TABLE
TOP FENIX NTM
TABLE / PIÉTEMENT
CHÊNE NATUREL,
PLATEAU FENIX NTM



CHAIR / FABRIC
DIVINA 3, LEGS
OAK LIGHT
CHAISE / TISSUS
DIVINA 3, PIÉTEMENT
CHÊNE CLAIR





CHAIR / FABRIC
DIVINA MD, LEGS
OAK LIGHT
CHAISE / TISSUS
DIVINA MD,
PIÈTEMENT CHÊNE
CLAIR

**The profile underlines
two triangular prisms.
They ensure the greatest
thickness of the foam on
the major points of support
for the body when sitting.**

**Le profil souligne deux
prismes triangulaires.
Ils assurent l'épaisseur
maximale au niveau des
points d'appuie du corps.**

NUMEN/FOR USE



CHAIR / FABRIC
DIVINA MD, LEGS
OAK LIGHT
CHAISE / TISSUS
DIVINA MD, PIÉTEMENT
CHÊNE CLAIR







Wooden House, Krk, Croatia / Project: Idis Turato
Photo: Bosnić+Dorotić



JGL Pharma Valley Rijeka, Croatia
Project: Igor Rožić & Davor Katušić with
associates / Photo: Sandro Rubinić



Play: King Lear, Athens, Greece / Scenography: Numen/ForUse / Photo: Aljoša Rebolj & Numen/ForUse



ARMCHAIR / FABRIC
HALLINGDAL 65, LEGS
OAK BLACK
FAUTEUIL / TISSUS
HALLINGDAL 65,
PIÉTEMENT CHÊNE
NOIR



OBLIQUE

72

OBLIQUE

CHAIR / CHAISE

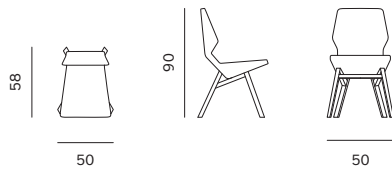

CHAIR METAL / CHAISE MÉTAL

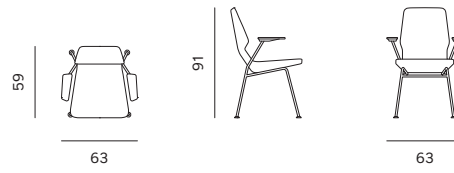

LOUNGE CHAIR / FAUTEUIL LOUNGE

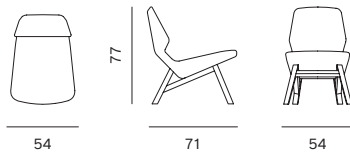

ARMCHAIR METAL / FAUTEUIL MÉTAL

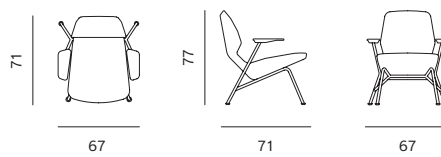

ARMCHAIR / FAUTEUIL

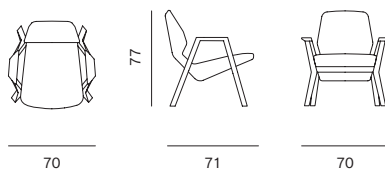

SMALL TABLES / TABLES BASSES

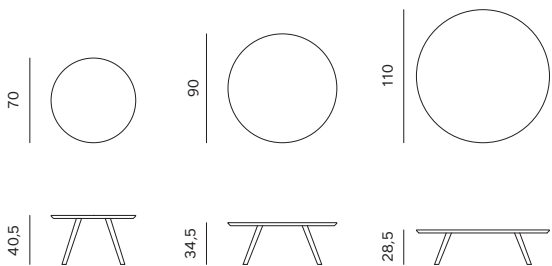

DINING TABLE / TABLE

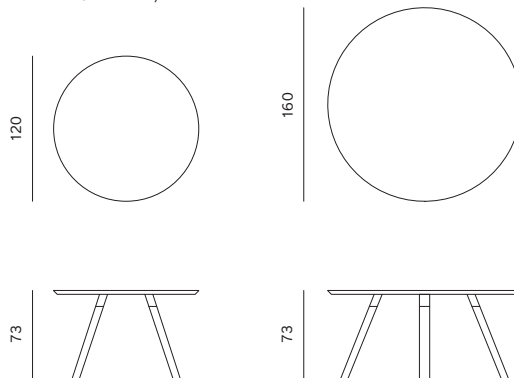

DINING TABLE / TABLE

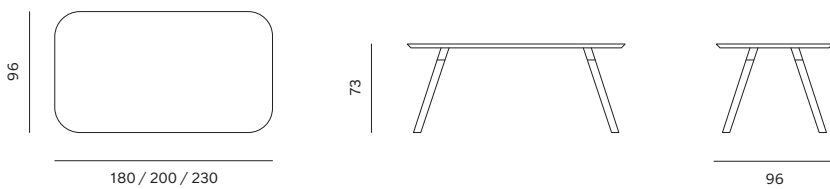

RED DOT DESIGN
AWARD 2015 WINNER

DOBRA



We have reinterpreted the traditional typology of a wooden chair with armrests using a characteristic 'break' in the geometry of front legs. Rounded geometry of turned armrests and the backrest is mirrored in the lenticular cushions. Primarily functional intersection between the legs and transversal bars on the seat maintains geometrical exactness. Intersections between the backrest and armrests, perceptible by touch, were created according to the principles of organic transformation of volume. Those contrasts between 'soft' and 'hard' elements and intersections shape the *Dobra's* characteristic formal language.

Nous avons réinterprété le modèle de chaise avec accoudoirs traditionnelle en bois en intégrant une cassure caractéristique dans la géométrie du piétement avant. La géométrie arrondie des accoudoirs en bois tourné et la courbe du dossier se reflètent dans la forme du coussin d'assise en lentille convergente. La fonctionnalité primaire de l'intersection entre les pieds et la barre transversale de la chaise maintient une exactitude géométrie. Les intersections entre le dossier et les accoudoirs, perceptibles au toucher, ont été créées selon les principes de la transformation organique des volumes. Les contrastes entre les éléments durs et doux ainsi que la particularité des intersections forment l'identité forte du *Dobra*.





CHAIR / FABRIC
STEELCUT TRIO 2,
OAK BLACK
CHAISE / TISSUS
STEELCUT TRIO 2,
CHÊNE NOIR



CHAIR / FABRIC
REMIX, OAK LIGHT
CHAISE / TISSUS
REMIX, CHÊNE CLAIR



**We have reinterpreted
the traditional typology
of a wooden chair
with armrests using a
characteristic 'break'
in the geometry of
front legs.**

Nous avons réinterprété
le modèle de chaise avec
accoudoirs traditionnelle
en bois en intégrant une
cassure caractéristique dans
la géométrie du piétement
avant.

79

NUMEN/FOR USE

DOBRA



prostorja



DOBRA

CHAIR / CHAISE

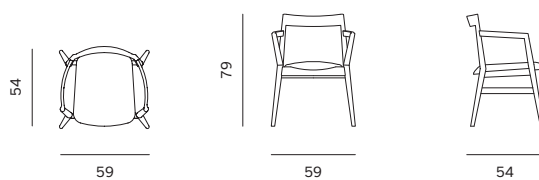

STRAIN



The *Strain* product family comprises an armchair, a bar stool and tables and small tables of various heights. This diversified product family shares one common feature: the design of the product base and legs, which is always a challenge. The solution for very distinguishable leg junctions is found in intertwining and intertwisting of steel tubes whose modular relations can change depending on a particular use. The result is a recognizable family of products with variations of a common basic idea where the concept of junctions is not only an appealing formal interplay but also an element that complements the hardness of the construction. Visually light and uncustomary slender, the *Strain* armchair offers extraordinary comfort due to the elasticity of leather and net fabric tightly stretched over the seat shell. A lumbar cushion provides additional comfortableness. A saddle served as the inspiration for the ergonomic design of the solid wood seat of the barstool. This entirely functional family is rounded off with multidimensional coffee tables with various finishes.

La ligne *Strain* se compose d'un fauteuil, d'un tabouret haut et de tables à hauteurs variables. Cette ligne hétéroclite a un point en commun: le design du piétement et des structures, toujours un défi. La solution pour créer les jonctions très reconnaissables a été trouvée dans l'entrelacement par la torsion des tubes en acier dont les relations moléculaires changeraient selon l'utilisation. Le résultat est une ligne de produits à identité forte comportant des variations d'une idée commune où le concept des jonctions serait non seulement une interaction de formes attrayantes mais également un élément qui met en valeur la solidité de la structure. Visuellement léger et d'une finesse peu commune, le fauteuil *Strain* offre un confort extraordinaire dû à l'élasticité du cuir et du tissu résille tendus sur la structure. Un coussin lombaire ajoute encore plus de confort. La selle d'équitation a servi d'inspiration pour la structure ergonomique de l'assise en bois massif du tabouret haut. Cette ligne parfaitement fonctionnelle est complétée par des tables basses multidimensionnelles en finitions diverses.

SMALL TABLE / TABLE
 STRUCTURE METAL
 COATED BLACK CHROME,
 TABLE TOP FENIX NTM
 TABLE BASSE / PIÉTEMENT
 STRUCTURE MÉTAL LAQUÉ
 CHROMÉ NOIR, PLATEAU
 FENIX NTM



ARMCHAIR /
 FABRIC CRAGGAN,
 STRUCTURE METAL
 COATED BLACK
 CHROME
 FAUTEUIL /
 TISSUS CRAGGAN,
 STRUCTURE MÉTAL
 LAQUÉ CHROMÉ
 NOIR







ARMCHAIR / FABRIC
HALLINGDAL 65, STRUCTURE
METAL COATED BLACK
FAUTEUIL / TISSUS
HALLINGDAL 65, STRUCTURE
MÉTAL LAQUÉ NOIR

This diversified product family shares one common feature: the design of the product base and legs, which is always a challenge. The solution for very distinguishable leg junctions is found in intertwining and intertwisting of steel tubes whose modular relations can change depending on a particular use.

Cette ligne hétéroclite a un point en commun: le design du piétement et des structures, toujours un défi. La solution pour créer les jonctions très reconnaissables a été trouvée dans l'entrelacement par la torsion des tubes en acier dont les relations moléculaires changeraient selon l'utilisation.

SIMON MORASI PIPERČIĆ



ARMCHAIR / MESH RUNNER,
FABRIC STEELCUT TRIO 2,
STRUCTURE METAL COATED
FAUTEUIL / RÉVILLE RUNNER,
TISSUS STEELCUT TRIO 2,
STRUCTURE MÉTAL LAQUÉ



ARMCHAIR / MESH RUNNER,
FABRIC STEELCUT TRIO 2,
STRUCTURE METAL COATED
FAUTEUIL / RÉVILLE MESH,
TISSUS STEELCUT TRIO 2,
STRUCTURE MÉTAL LAQUÉ







STOOL / SEAT OAK NATURE,
LEGS METAL COATED BLACK
TABOURET DE BAR / ASSISE
CHÊNE NATUREL, PIÈTEMENT
MÉTAL LAQUÉ NOIR

ARMCHAIR / MESH RUNNER,
FABRIC STEELCUT TRIO 2,
STRUCTURE METAL COATED
FAUTEUIL / RÉVILLE MESH,
TISSUS STEELCUT TRIO 2,
STRUCTURE MÉTAL LAQUÉ



STRAIN

LOUNGE CHAIR / FAUTEUIL LOUNGE

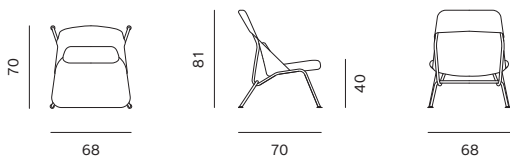

SMALL TABLE / TABLE BASSE

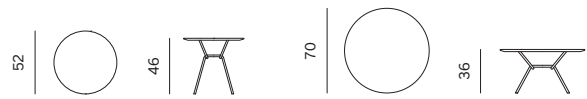

BAR STOOL HIGH / TABOURET DE BAR HAUT

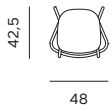

BAR STOOL LOW / TABOURET DE BAR BASS

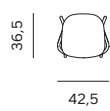

STOOL / TABOURET

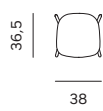

TABLE / TABLE

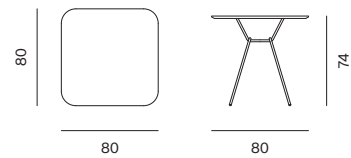
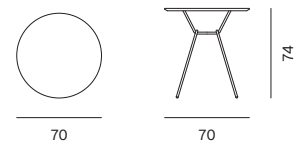
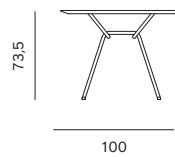
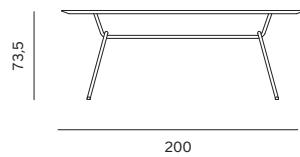
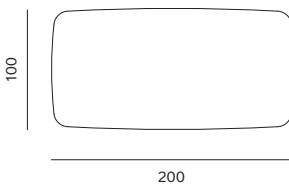

TABLE / TABLE



INTERIOR INNOVATION AWARD 2015 WINNER
 RED DOT DESIGN AWARD 2015 WINNER
 GOLDEN KEY AWARD 2015 WINNER

3ANGLE 94



COMBINE 104



MATCH 114



CLOUD 126

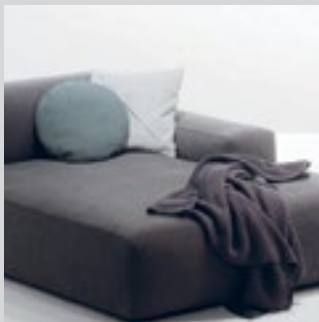

ELEGANCE 136

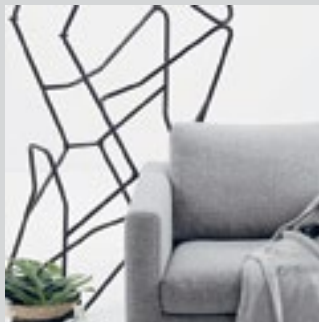

CLASSIC 144

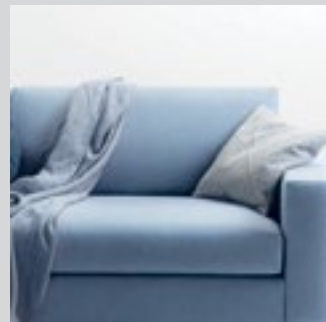

CONVERT 152



SEGMENT 162



SEAM 174

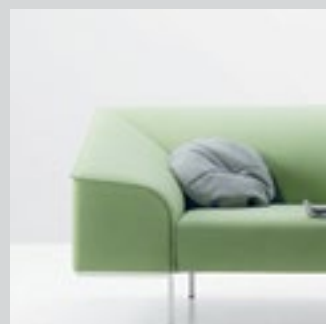

FRAME 182



COMBO 184

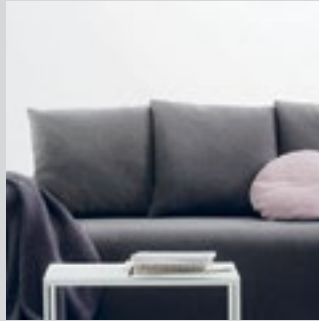

UP-LIFT 192



REVOLVE 200



PIL-LOW 208



SIMETRIA 214

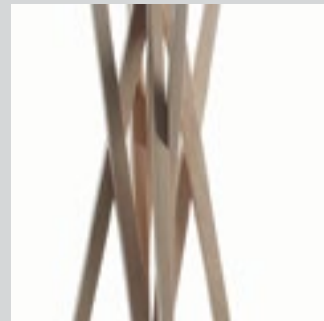

3ANGLE

DESIGN: GRUPA



The *3angle* armchair and two-seater sofa is a result of mindful and persistent product development that **prostor**a grants to its designers. Following a competition in 2011, the project has undergone a number of transformations tested on prototypes while simultaneously preserving the original design idea. Fragmented, crystal-like forms systematically describing a compact volume, almost like an algorithm, characterize the design. This solution is not only formal - the characteristic *3angle* armrests follow the ergonomic line of relaxed arms. A soft shell of the backrest and armrest is covered with a continuous cover whose edges are marked only with a very subtle line of stitches. A light metal sub-construction reproduces the characteristic triangular motif contributing to the compactness of the composition. The *3angle* is a self-confident yet very disciplined formal step forward whose strong identity does not interfere with fitting in various ambiances.

Le fauteuil et le canapé deux places *3angle* sont un exemple du développement produit conscient et persistant que **prostor**a accorde à ses designers. Suite à une compétition en 2011, le projet a subi de nombreuses transformations testées sur des prototypes tout en gardant l'esprit du design d'origine. Des formes de cristaux fragmentés qui décrivent un volume compact de façon systématique, presque comme un algorithme, caractérisent le design du *3angle*. Ce volume n'est pas une forme quelconque car l'accoudoir caractéristique du *3angle* suit la ligne ergonomique d'un bras au repos. Le dossier et l'accoudoir rembourrés sont soulignés d'une surpiqûre subtile au niveau des arêtes. Une structure métal légère qui reproduit le motif triangulaire caractéristique de l'assise contribue à rendre la composition compacte. Le *3angle* est une avancée du point de vue de la forme, confiant mais méthodique, dont la forte personnalité ne l'empêchera pas de s'accorder avec différentes ambiances.



97

3ANGLE



prostorja



ARMCHAIR / FABRIC
DIVINA MD, LEGS
METAL COATED
BLACK 9005
FAUTEUIL /
TISSUS DIVINA MD,
PIÉTEMENT MÉTAL
LAQUÉ NOIR 9005



Fragmented, crystal-like forms systematically describing a compact volume, almost like an algorithm, characterize the design. *3angle* is a self-confident yet very disciplined formal step forward whose strong identity does not interfere with fitting in various ambiances.

Des formes de cristaux fragmentés qui décrivent un volume compact de façon systématique, presque comme un algorithme, caractérisent le design du *3angle*. Le *3angle* est une avancée du point de vue de la forme, confiant mais méthodique, dont la forte personnalité ne l'empêchera pas de s'accorder avec différentes ambiances.

GRUPA



2SEATER / FABRIC
DIVINA MD, LEGS
METAL COATED
BLACK 9005
CANAPÉ 2 PLACES /
TISSUS DIVINA MD,
PIÉMENT MÉTAL
LAQUÉ NOIR 9005

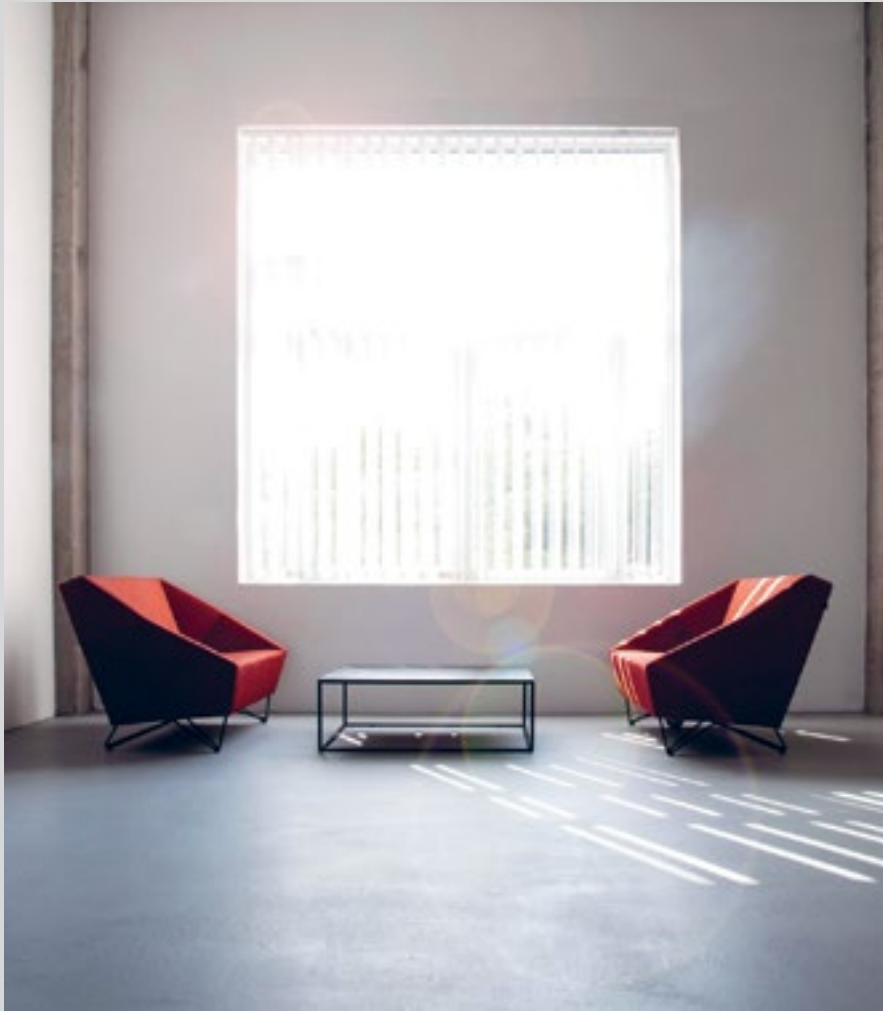

Seven Bridges Genomics offices, New Belgrade, Serbia / Project: Antipod studio / Photo: Marinka Tanasković



Marina Poreč, Croatia
Project: Krel Kostrenčić
Architects / Photo:
Miljenko Bernfest Berni

POUF / FABRIC
DIVINA MD, DIVINA 3,
LEGS METAL COATED
BLACK 9005
POUF / TISSUS DIVINA
MD, DIVINA 3, PIÉTEMENT
LAQUÉ NOIR 9005





104

3ANGLE



2017

3ANGLE

ARMCHAIR / FAUTEUIL

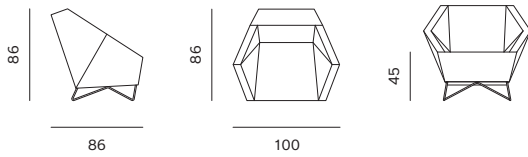

2SEATER / CANAPÉ 2 PLACES

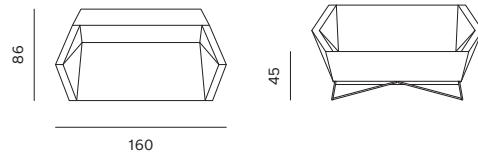

POUF / POUF

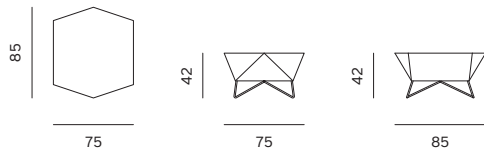

4ANGLE SMALL TABLE / 4ANGLE TABLE BASSE

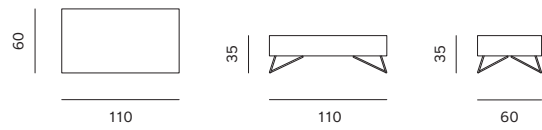

COMBINE

DESIGN: NUMEN/FOR USE



A standard sofa with feather cushions served as the starting point in designing the *Combine*. This standard form provides the most comfortable sitting but it is usually very voluminous. Our solution introduces sloped lateral and rear parts of the backrest, which results in both visual and literal reduction of the backrest's volume and height. Horizontal surfaces following the line of the extended seating and laying module are designed to serve both for sitting and putting things away. Depending on the selection of wooden or metal legs and extra cushions, the *Combine's* style and context of use change, offering an opportunity to every user to define the character of the sofa individually.

Un canapé standard avec des coussins en plumes a servi de point de départ pour la création du *Combine*. Cette forme standard procure le meilleur confort mais est habituellement très volumineuse. Notre solution introduit des parties latérales et arrières du dossier inclinées, ce qui donne une réduction visuelle et réelle du volume et de la hauteur du dossier. Des surfaces horizontales qui logent les extérieurs des méridiennes ou des modules de détente sont créées tout autant pour s'asseoir que pour y poser des objets. Le style et l'utilisation du *Combine* changent selon la sélection des piétements en bois ou en métal. Les coussins supplémentaires, offrent à chacun la possibilité de personnaliser son canapé.



2SEATER / FABRIC
OPERA MIRROR, LEGS
WALNUT, COPULINGS
COATED BLACK 9005
CANAPÉ 2 PLACES / TISSUS
OPERA MIRROR, PIÉTEMENT
NOYER, COUPLER
LAQUÉS NOIR 9005



MONK ARMCHAIR /
FABRIC CANVAS,
LEGS OAK NATURE
FAUTEUIL MONK / TISSUS
CANVAS, PIÉTEMENT CHÊNE
NATUREL

Our solution introduces sloped lateral and rear parts of the backrest, which results in both visual and literal reduction of the backrest's volume and height.

Notre solution introduit des parties latérales et arrières du dossier inclinées, ce qui donne une réduction visuelle et réelle du volume et de la hauteur du dossier.

109

NUMEN/FOR USE

COMBINE



prostorja



CHAISE LOUNGE / FABRIC
SYNERGY, LEGS WALNUT,
COUPLING COATED BLACK 9005
MÉRIDIENNE / TISSUS SYNERGY,
PIÉTEMENT NOYER, TRAVERSES
LAQUÉS NOIR 9005



Meizai, Australia / Photo: Bek Sheppard



Microsoft DOOEL Skopje
Author: KL studio
Project Management:
BATES doo Belgrade
Photo: Andrijana Tilic



Private apartment, Paris, France / Project and photo: Atelier tropique



COMBINE

115

3SEATER / CANAPÉ 3 PLACES, 2,5SEATER / CANAPÉ 2,5 PLACES, 2SEATER / CANAPÉ 2 PLACES,

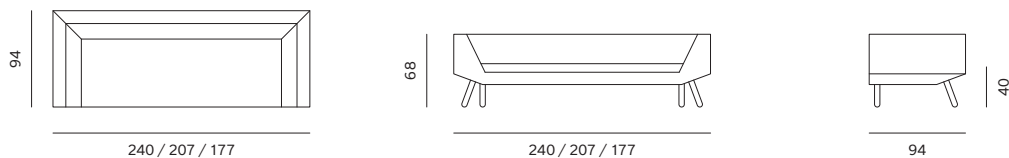

END UNIT (L/R) / MODULE ACCOUDOIR (G/D)

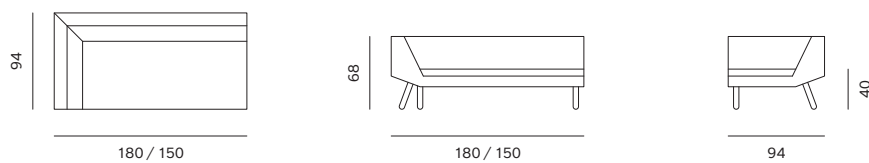

CHAISE LOUNGE (L/R) / MÉRIDienne (G/D)

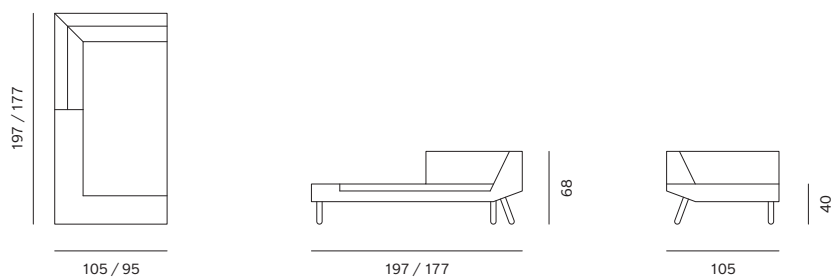

COMBINE

MATCH



The *Match* modular sofa reflects the standards of good design; however, its appearance and ways of using suggest a subtle break from the convention. The backrest is somewhat lower while the armrests are elevated which results in a specific composition and sitting experience. The user can choose between two different widths or depths of the module to obtain spatially and functionally optimal sofa. Its discretely designed form accentuates colours and textures of a variety of fabrics. The *Match* is an example of a well-designed sofa reduced to essential solutions. This approach made it one of the most successful products designed by **prostoria**.

Le canapé modulaire *Match* regroupe toutes les caractéristiques d'un design réussi : mais son apparence et son utilisation brisent subtilement les conventions. Le dossier est abaissé tandis que les accoudoirs s'élèvent, ce qui lui donne un aspect particulier et un confort d'assise certain. L'utilisateur peut choisir entre deux largeurs et profondeurs d'assise afin de composer un canapé fonctionnel et adapté à l'espace de façon optimale. Sa forme discrète met en valeur les couleurs et textures des divers tissus. Le *Match* est l'exemple d'un canapé bien désigné concentré sur l'essentiel. Cette approche en a fait un des produits ayant le plus de succès créé par **prostoria**.



POLYGON
ARMCHAIR /
FAUTEUIL

MODULAR COMPOSITION
/ FABRIC MOLLY 2
COMPOSITION MODULABLE
/ TISSUS MOLLY 2



POUF /
FABRIC
MOLLY 2
POUF /
TISSUS
MOLLY 2



STRAIN ARMCHAIR /
FABRIC HALLINGDAL 65,
STRUCTURE METAL
COATED BLACK
STRAIN FAUTEUIL /
TISSUS HALLINGDAL 65,
PIÉTEMENT MÉTAL
LAQUÉ NOIR

Discretely designed form accentuates colours and textures of a variety of fabrics. The *Match* is an example of a well-designed sofa reduced to essential solutions.

Sa forme discrète met en valeur les couleurs et textures des diverses tissus. Le *Match* est l'exemple d'un canapé bien désigné concentré sur l'essentiel.

SANJA KNEZOVIĆ





prostorija Showroom, Zagreb / Photo: Vanja Šolin



LeviNine offices, Belgrade, Serbia
Project: OSA projekti, Ivana Kovačević / Photo: Relja Ivanić



Seven Bridges Genomics offices, New Belgrade, Serbia
Project: Antipod studio / Photo: Relja Ivanić





123

MATCH



prostorja







MATCH

1SEATER / CHAUFFEUSE

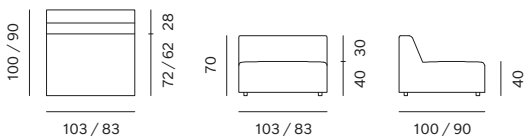

1SEATER + ARMREST (L/R) / CHAUFFEUSE + ACCOUDOIR (G/D)

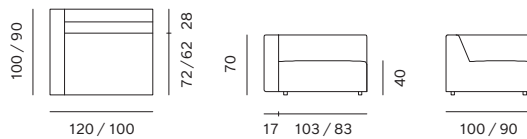

1SEATER EXTENDED (L/R) / CHAUFFEUSE PROLONGÉE (G/D)

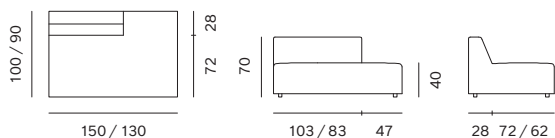

CORNER / ANGLE

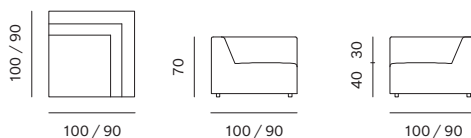

CORNER EXTENDED (L/R) / ANGLE PROLONGÉE (G/D)

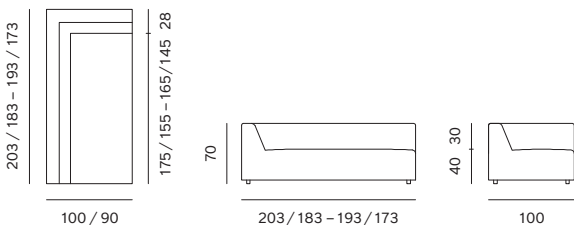

CHAISE LOUNGE (L/R) / MÉRIDienne (G/D)

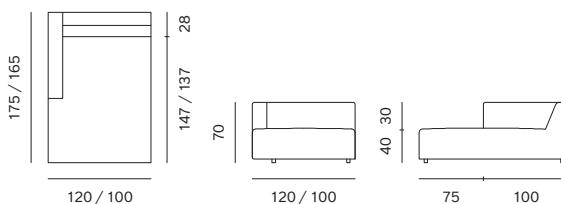

2SEATER + ARMREST (L/R) / CANAPÉ 2 PLACES + ACCOUDOIR (G/D)

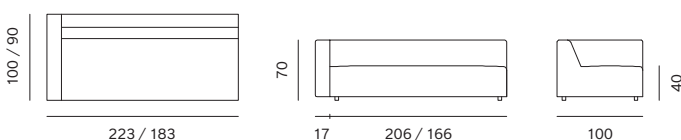

ISLAND / ILÔT

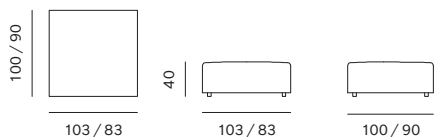

ARMCHAIR / FAUTEUIL

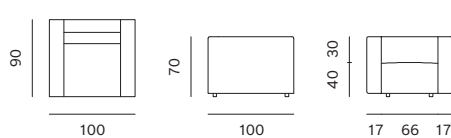

POUF / TABOURET

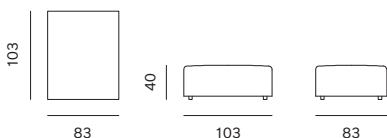

POUF / TABOURET



CLOUD

DESIGN: SANJA KNEZOVIC



The *Cloud* sofa was created as an opposing reaction to the basic model and pattern used for the design of the *Match* sofa. This visually attractive sofa with simple lines invites you to sit down and relax. The support made of cold foam reinforces the volume while the surface feather-filled layer provides a unique softness and sense of taking a rest in the midst of clouds. Modularity and variety of armrests allow for a very wide scope of functions. However, the *Cloud* sofa is particularly suitable for large spaces. It is particularly impressive in aniline leather upholstery with accentuated details on the seams.

Le canapé *Cloud* a été créé en opposition au modèle et patron de base du canapé *Match*. Ce beau canapé aux lignes simples vous invite à la détente. Le soutien en mousse froide augmente le volume tandis que les coussins de surface en plumes procurent un moelleux unique et donnent l'impression d'être sur un nuage. Une grande modularité et différentes hauteurs d'accoudoirs permettent des compositions infinies. De fait de son volume, le canapé *Cloud* est spécifiquement adapté aux grands espaces. Il est particulièrement impressionnant en version cuir aniline avec des coutures contrastantes.

CHAISE LOUNGE /
FABRIC HALLINGDAL 65
MÉRIDIENNE 2 PLACES /
TISSUS HALLINGDALE 65



This visually attractive sofa with simple lines invites you to sit down and relax. Modularity and variety of armrests allow for a very wide scope of functions. However, the *Cloud* sofa is particularly suitable for large spaces.

Ce beau canapé aux lignes simples vous invite à la détente. Une grande modularité et différentes hauteurs d'accoudoirs permettent des compositions infinies. De fait de son volume, le canapé *Cloud* est spécifiquement adapté aux grands espaces.

SANJA KNEZOVIĆ



MODULAR COMPOSITION /
FABRIC HALLINGDAL 65
COMPOSITION MODULABLE /
TISSUS HALLINGDAL 65

130

CLOUD

2017



RHOMB
CHAIR /
OAK LIGHT
CHAISE
/ CHÊNE
CLAIR

MONK TABLE
/ OAK NATURE
TABLE / CHÊNE
NATUREL







Private house Gumno, Krk, Croatia / Project: Idis Turato / Photo: Bosnić+Dorotić





Studio Scenography, Zagreb, Croatia / Photo: Domagoj Kunić

FABRIC / TISSUS
HALLINGDAL 65

136

CLOUD

2017



CLOUD

1SEATER / CHAUFFEUSE

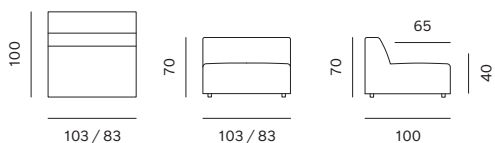

1SEATER + ARMREST (L/R) / CHAUFFEUSE + ACCOUDOIR (G/D)

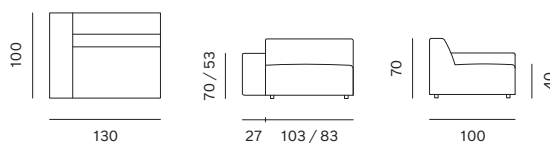

2SEATER + ARMREST (L/R) / CANAPÉ 2 PLACES + ACCOUDOIR (G/D)

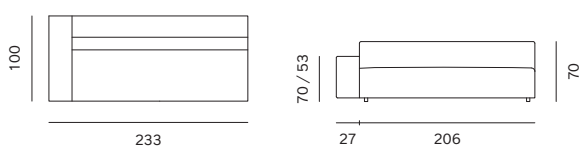

ISLAND / ILÔT

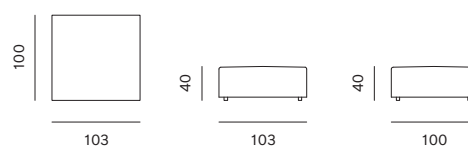

CHAISE LOUNGE (L/R) / MERIDIENNE (G/D)

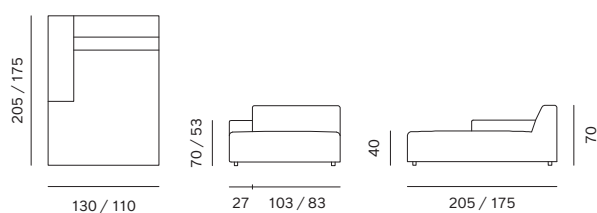

CORNER / ANGLE

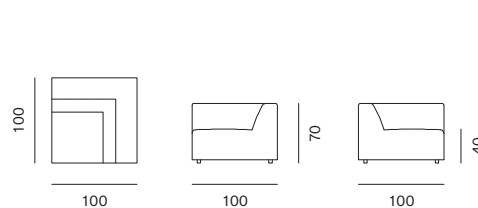

CORNER ASIMETRICAL (L/R) / ANGLE ASSYMETRIQUE (G/D)

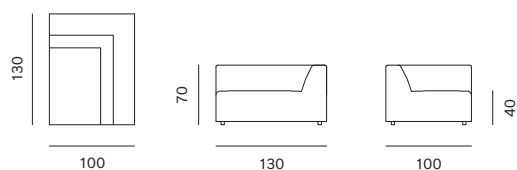

ARMCHAIR / FAUTEUIL

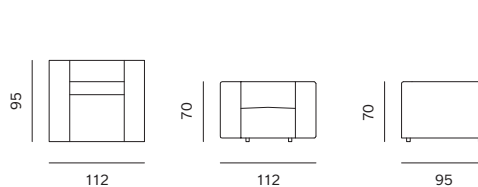

1SEATER EXTENDED (L/R) / 1 PLACE PROLONGÉE (G/D)

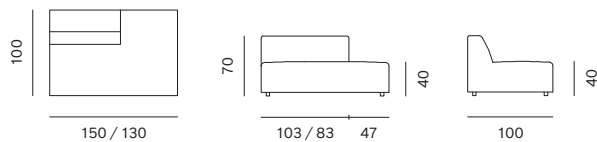

POUF / POUF

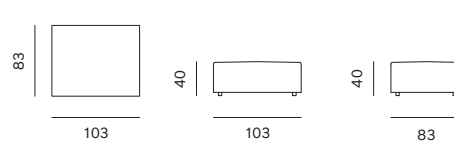

ELEGANCE

The *Elegance*, together with the *Classic*, represents the outset of **prostoria**. To us, the design of *Elegance* meant an exploration of the refinement of form, finding the moment in which visual ease and clear sublimated geometry meet. The sofa and armchair frames are relatively thin and somewhat lower, emphasizing the appearance of the cushions and thus underlining comfort. This also helps to lighten the entire volume of the sofa. In contrast to the rigid structure, the seat cushions have slightly rounded edges. The cushions are offered in two alternatives: a softer, visually gentler one, and a harder one that is geometrically more rigid. The visual variability of the set is supplemented by an offering of metal or more classic wooden legs. By combining a series of subtle shifts within a set of accepted rules, we have designed a product characterised by a discreet contemporary elegance and adaptability to different environments.

Les ensembles d'assises modulaires *Elegance* et *Classic* représentent les débuts de **prostoria**. Pour nous, le design de l'*Elegance* était une exploration de l'amélioration de la forme, visant à ce que le confort visuel rencontre la géométrie nette sublimée. Les structures du canapé et fauteuil sont relativement fines et plus basses, mettant de ce fait l'accent sur les coussins et soulignant ainsi leur confort. Ceci permet également d'alléger le volume global du canapé. Les coussins de l'assise ont des bords légèrement arrondis en contraste avec la structure rigide. Deux versions de coussins sont proposées ; une plus moelleuse, visuellement plus douce et une plus dure, géométriquement plus rigide. La personnalisation se complète par une proposition de choix de piétements en bois classique ou en métal. Par la combinaison d'une série de changements au sein de règles reconnues, nous avons créé un produit caractérisé par une élégance contemporaine discrète et une adaptabilité aux différents environnements.



POLYGON
SMALL TABLE /
LEGS METAL COATED
BLACK, TABLE TOP
FENIX NTM
TABLE BASSE /
PIÉMENT MÉTAL
LAQUÉ NOIR,
PLATEAU FENIX NTM

140

ELEGANCE

4SEATER / FABRIC
HALLINGDAL, LEGS
METAL COATED BLACK
CANAPÉ 4 PLACES / TISSUS
HALLINGDAL, PIÉTEMENT
MÉTAL LAQUÉ NOIR

POLYGON
ARMCHAIR / FABRIC
HALLINGDAL 65, LEGS
METAL COATED BLACK
FAUTEUIL / TISSUS
HALLINGDAL 65,
PIÉTEMENT MÉTAL
LAQUÉ NOIR

2017

The *Elegance*, together with the *Classic*, represents the outset of **prostoría**. By combining a series of subtle shifts within a set of accepted rules, we have designed a product characterised by a discreet contemporary elegance and adaptability to different environments.

Les ensembles d'assises modulaires *Elegance* et *Classic* représentent les débuts de **prostoría**. Par la combinaison d'une série de changements au sein de règles reconnues, nous avons créé un produit caractérisé par une élégance contemporaine discrète et une adaptabilité aux différents environnements.

141

ELEGANCE

PROSTORIA



POLYGON
SMALL TABLE / LEGS
METAL COATED BLACK,
TABLE TOP FENIX NTM
TABLE BASSE /
PIÉTEMENT MÉTAL
LAQUÉ NOIR, PLATEAU
FENIX NTM

prostoría

ARMCHAIR / FABRIC
HALLINGDAL, LEGS
OAK BLACK
FAUTEUIL / TISSUS
HALLINGDAL, PIÉTEMENT
CHÊNE NOIR





Hotel President, Dubrovnik, Croatia / Photo: Damir Fabijanić



prostorija Showroom, Zagreb, Croatia / Photo: Domagoj Kunić

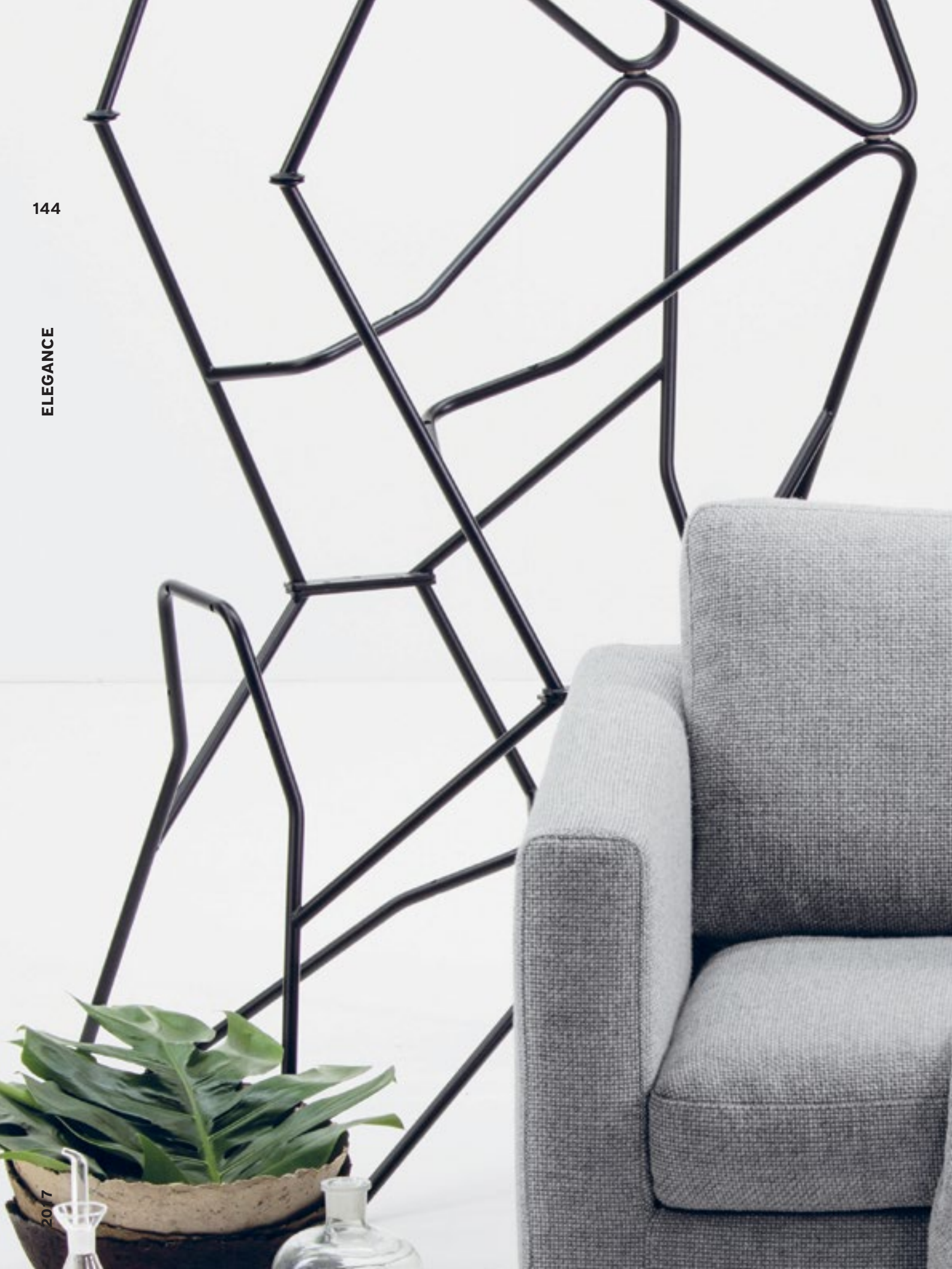

ELEGANCE

145

ARMCHAIR / FAUTEUIL

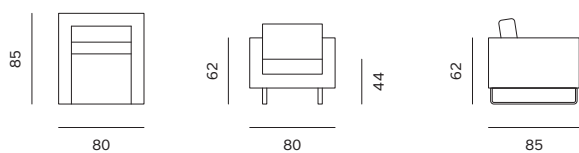

POUF / POUF

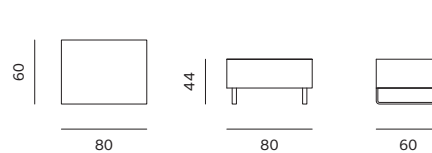

2SEATER / CANAPÉ 2 PLACES

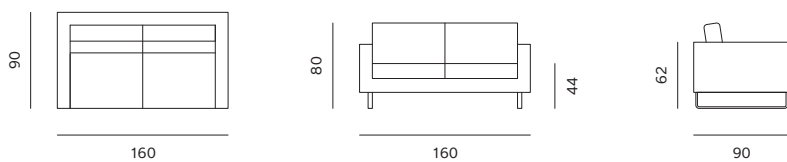

3SEATER / CANAPÉ 3 PLACES

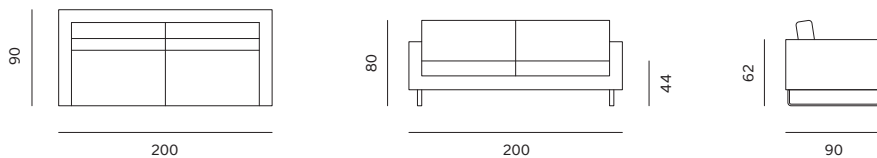

4SEATER / CANAPÉ 4 PLACES

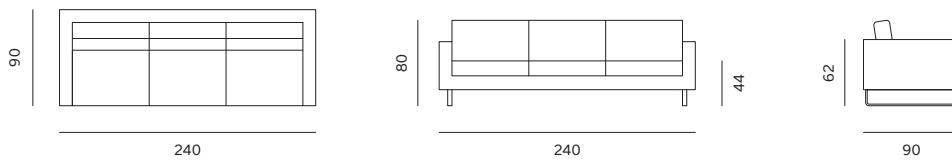

ELEGANCE

CLASSIC

The timeless design of the *Classic* modular seating set represents, along with the *Elegance* set, the first product line and origin of the company, indicating our fundamental values. Designing the *Classic* was a considerable challenge: how to work out a product that fits into well-established forms, while also creating an added value? The *Classic* set is unintrusive, but its prototypical conception and formal rigidity give it a universal reliable character. It is precisely this universality that allows the soundness of the design and the quality of the materials to speak for themselves. The variety of modules and variations in their width have contributed to the popularity of the set, making it equally suitable for both public and residential spaces.

Le design intemporel de l'ensemble de la collection *Classic* représente, avec l'ensemble de la collection *Elegance*, la première ligne de produits aux débuts de la société et révèle ainsi nos valeurs fondamentales. La création du *Classic* était un défi considérable: comment travailler un produit qui reste dans les formes ayant fait leurs preuves tout en apportant une valeur ajoutée ? L'ensemble *Classic* est discret, mais sa conception prototypique et sa rigidité formelle lui donnent un caractère universellement fiable. C'est précisément cette universalité qui permet au design solide et aux qualités des matériaux de s'exprimer. La diversité des modules et leurs différentes largeurs ont contribué au succès de la ligne et font qu'elle soit adaptée tout autant aux espaces résidentiels que professionnels.



147

CLASSIC



OBLIQUE
SMALL TABLE /
TABLE TOP
FENIX NTM,
LEGS OAK LIGHT
TABLE BASSE
OBLIQUE /
PLATEAU FENIX
NTM, PIÉTEMENT
CHÊNE CLAIR

prostoría



Castle Sveti Križ Začretje, Croatia / Photo: Domagoj Kunić



ARMCHAIR, POUF /
FABRIC MAINLINE FLAX
FAUTEUIL, POUF /
TISSUS MAINLINE FLAX



The *Classic* set is unintrusive, but its prototypical conception and formal rigidity give it a universal reliable character. It is precisely this universality that allows the soundness of the design and the quality of the materials to speak for themselves.

L'ensemble *Classic* est discret, mais sa conception prototypique et sa rigidité formelle lui donnent un caractère universellement fiable. C'est précisément cette universalité qui permet au design solide et aux qualités des matériaux de s'exprimer.

PROSTORIA



OBLIQUE
SMALL TABLE /
TABLE TOP /
FENIX NTM,
LEGS OAK LIGHT
TABLE BASSE /
PLATEAU FENIX
NTM, PIÉTEMENT
CHÉNE CLAIR

MODULAR COMPOSITION
/ FABRIC MAINLINE FLAX
COMPOSITION MODULABLE
/ TISSUS MAINLINE FLAX





CLASSIC

1SEATER / 1 PLACE

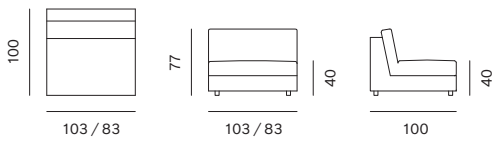

1SEATER + ARMREST (L/R) / 1 PLACE + ACCOUDOIR (G/D)

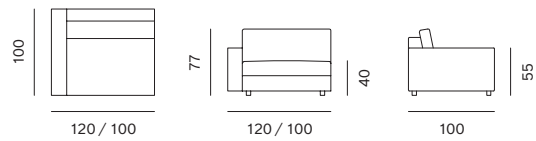

1SEATER + EXTENDED (L/R) / 1 PLACE PROLONGÉE (G/D)

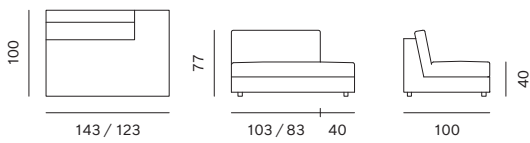

CHAISE LOUNGE (L/R) / MÉRIDienne (G/D)

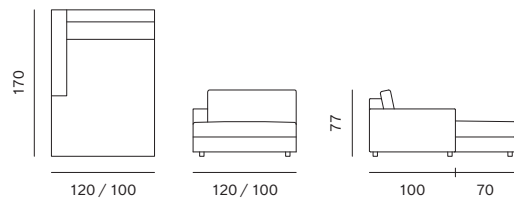

3SEATER / 3 PLACES, 2,5SEATER / 2,5 PLACES, 2SEATER / 2 PLACES

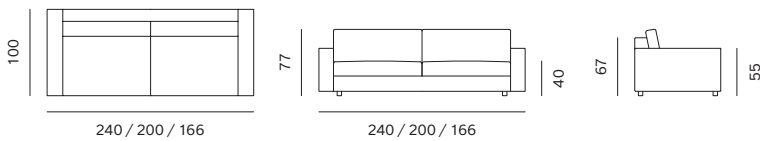

POUF / POUF

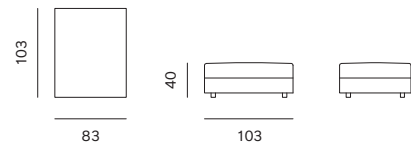

CORNER EXTENDED (L/R) / ANGLE PROLONGÉ (G/D)

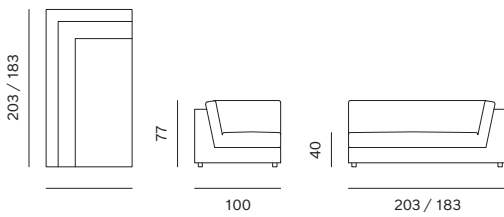

CORNER / ANGLE

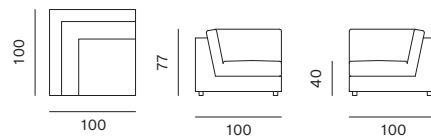

3SEATER + MATTRESS / 3 PLACES + MATELAS
2,5SEATER + MATTRESS / 2,5 PLACES + MATELAS

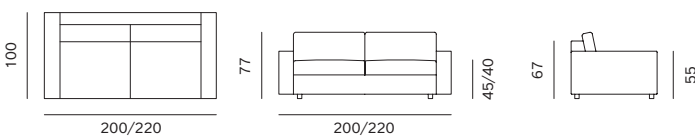

ARMCHAIR / FAUTEUIL

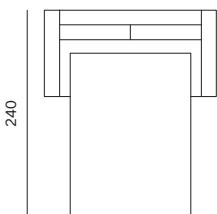
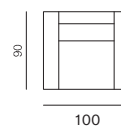

CONVERT



While designing the *Convert*, my intention was to take a step forward from the standard model of modular furniture. We have been thinking about an open system that can accommodate multiple changes in form, spatial arrangement and function, which is interactive and developing together with the user at the same time stimulating his or her imagination. New situations, equally suitable for homes and public spaces, are created by freely combining or upgrading the basic elements – seating modules, fixed or movable backrests and storage platforms. The modules are discrete in shape yet their open system concept and the use of various materials make every group unique and distinctive.

Lors de la création du *Convert*, mon intention était de faire évoluer le modèle type du meuble modulaire. Nous avons réfléchi à une structure ouverte pouvant accommoder de multiples évolutions de forme, de positionnement spatial et de fonction. L'interactivité créée avec l'utilisateur de cette façon stimule en même temps l'imagination. De nouveaux ensembles, tout autant adaptés aux espaces résidentiels que publics, sont créés en associant ou en complétant les éléments de base ; modules d'assise, dossiers fixes ou amovibles et tablettes. Les formes des modules restent discrètes, mais leur système ouvert et l'utilisation de matériaux variés rendent chaque composition unique et distinctive.



We have been thinking about an open system that can accommodate multiple changes in form, spatial arrangement and function, which is interactive and developing together with the user at the same time stimulating his or her imagination.

Nous avons réfléchi à une structure ouverte pouvant accommoder de multiples évolutions de forme, de positionnement spatial et de fonction. L'interactivité créée avec l'utilisateur de cette façon stimule en même temps l'imagination.

SIMON MORASI PIPERČIĆ







3SEATER /
LEATHER
ELMOSOFT
CANAPÉ 3
PLACES /
CUIR
ELMOSOFT





161

CONVERT

prostorja



CONVERT

COMPONENTS / COMPOSANTS

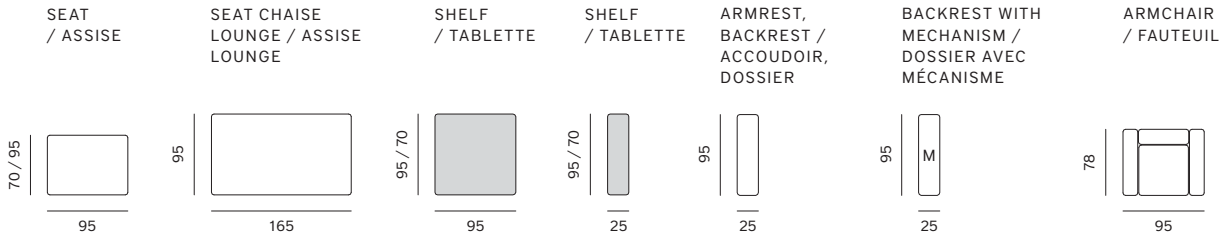

COMPOSITION EXAMPLES / EXEMPLES DE COMPOSITIONS

1SEATER / 1 PLACE

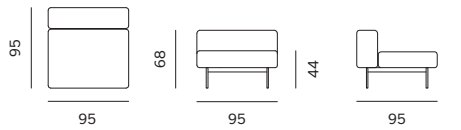

3SEATER / 3 PLACES

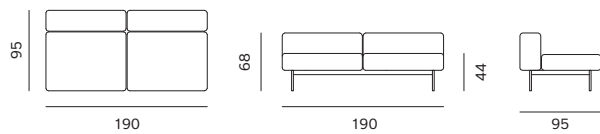

1SEATER / 1 PLACE

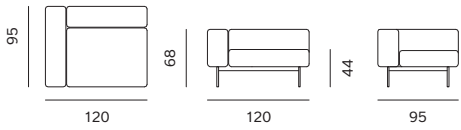

3SEATER / 3 PLACES

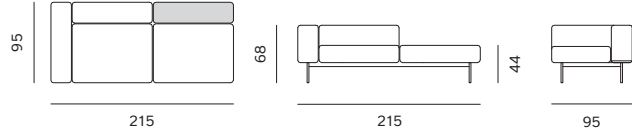

1SEATER / 1 PLACE

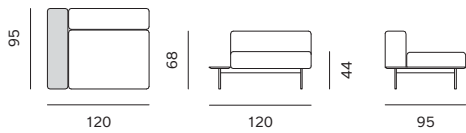

3SEATER / 3 PLACES

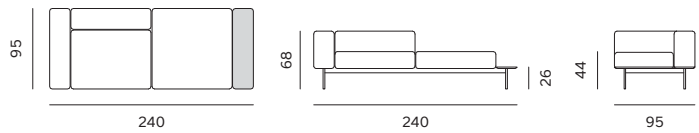

CHAISE LOUNGE / MERIDIENNE

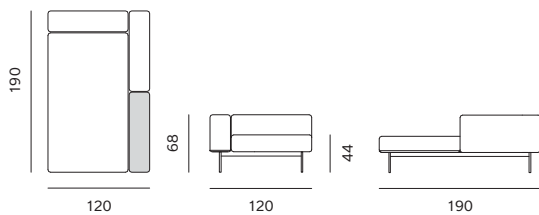

BIG COMPOSITION / GRANDE COMPOSITION

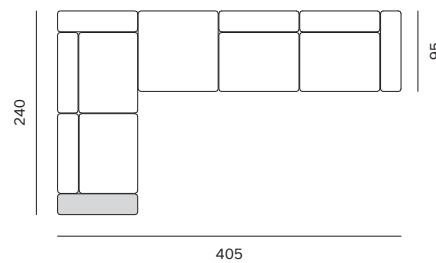

SEGMENT

DESIGN: NUMEN/FOR USE



When designing the *Segment*, we were interested in finding a solution for the hierarchy in combining elements for modular upholstered furniture. In the case of any conventional modular sofa, there is always one element that 'dominates' and directs the system of combinations. In the case of the *Segment*, borders on the main element used for the seat, backrest and armrests are sloped at a 45-degree angle. This allows free combining of the system on all three axes. The main reference for this design was the seven-segment character display used on earlier digital clocks. That is also how the sofa got its name. With this concept, the user has the opportunity to compose various and even unconventional compositions in space. Countless combinations of the base and backrest form a system that is functional and open for designing diverse interior landscapes.

En créant *Segment*, nous nous sommes intéressés à trouver une solution alternative pour l'organisation des différents éléments d'un canapé modulable rembourré. Dans le cas d'un canapé modulable classique il y a toujours un élément qui domine les autres et qui dirige l'organisation de ces autres éléments. Dans le cas du *Segment*, les bordures de l'élément principal servant d'assise, de dossier ou d'accoudoir, forment des pans coupés à 45°. Ceci donne une liberté entière d'assemblage sur les trois axes. L'inspiration pour ce design était l'affichage en sept segments des premières horloges digitales et ceci donna également le nom au canapé. Avec ce concept, l'utilisateur a la possibilité de créer différentes et surprenantes compositions. D'innombrables combinaisons de la base et du dossier forment un système fonctionnel parfait et adapté à la création des scénographies d'intérieur diverses.





'SNAKE' MODULAR
COMPOSITION / FABRIC TOPIA,
LEGS METAL COATED 5003
COMPOSITION MODULABLE
'SERPENT' / TISSUS TOPIA,
PIÉTEMENT MÉTAL LAQUÉ 5003





Business centre Spectator Solis, Zagreb, Croatia / Photo: Domagoj Kunić

ARMCHAIR / FABRIC
DIVINA MD, LEGS
METAL COATED 9003
FAUTEUIL / TISSUS
DIVINA MD, PIÉTEMENT
METAL LAQUÉ 9003



In the case of the *Segment*, borders on the main element used for the seat, backrest and armrests are sloped at a 45-degree angle. This allows free combining of the system on all three axes.

Dans le cas du *Segment*, les bordures de l'élément principal servant d'assise, de dossier ou d'accoudoir, forment des pans coupés à 45°. Ceci donne une liberté entière d'assemblage sur les trois axes.

NUMEN/FOR USE



MODULAR COMPOSITION
WITH PLATFORM / FABRIC
DIVINA MD, LEGS METAL
COATED 9003
COMPOSITION MODULABLE
AVEC PODIUM / TISSUS
DIVINA MD, PIÉTEMENT
MÉTAL LAQUÉ 9003

SEGMENT



SMALL TABLE /
TABLE TOP MDF,
LEGS METAL
COATED 9003
TABLE BASSE /
PLATEAU MDF,
PIÉTEMENT MÉTAL
LAQUÉ 9003





PLATFORM /
MDF LACQUERED
PODIUM / MDF
LAQUÉ





Radisson Blue
Hotel, Helsinki,
Finland / Project:
Sisustusarkkitehdit
Fyra Oy / Photo:
Eeli Saaristo



Castle Sveti Križ, Croatia / Photo: Domagoj Kunić

MODULAR
COMPOSITION
WITH PLATFORM /
FABRIC TOPIA
COMPOSITION
MODULABLE AVEC
PODIUM /
TISSUS TOPIA



SEGMENT

ARMCHAIR
/ FAUTEUIL



2SEATER
/ 2 PLACES

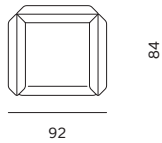

3SEATER
/ 3 PLACES



'SNAKE'
/ 'SERPENT'

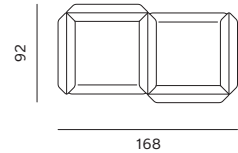

1SEATER BASE
/ CHAUFFEUSE BASE

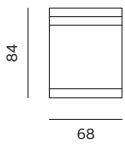

1SEATER HALF
MOD (L/R) /
CHAUFFEUSE DEMI
MODULE (G/D)

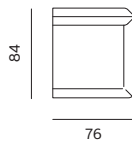

1SEATER MOD
/ CHAUFFEUSE
MODULE
COMPLÈTE

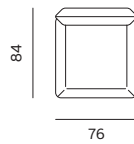

CORNER
/ ANGLE

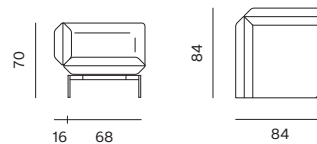

ARMREST DIVISION /
ACCOUDOIR SÉPARATEUR

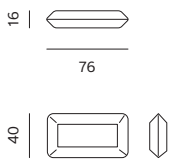

PLATFORM WITH OR WITHOUT
DRAWERS / PODIUM AVEC OU
SANS TIROIRS

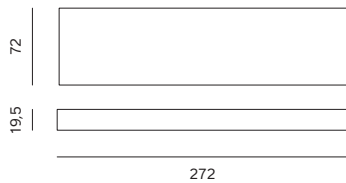

PLATFORM WITH OR WITHOUT
DRAWERS / PODIUM AVEC OU SANS
TIROIRS

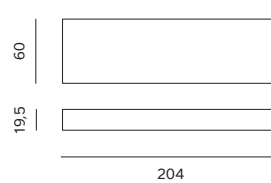
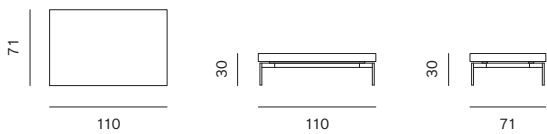
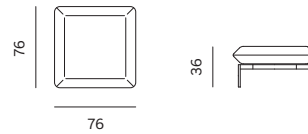

TABLE / TABLE



POUF / POUF



SEAM



The design of the *Seam* sofa is the result of our efforts to integrate elegant form and the purity of a single volume for comfortable sitting, without cushions that are often reminiscent of residential settings. The extremely deep armrest and backrest sink in an expressive curve towards the seat, which represents an ergonomic solution and is at the same time the trademark of the sofa's identity. The geometry of the curvature is accentuated with the stitches on the covers. The sofa's volume is integrated and continues along the height of the armrest and backrest. Despite its rigid geometry reduced to elementary gestures, the sofa nevertheless invokes various organic associations, such as a fan or seashell. It is perhaps precisely this ambivalence that has ensured its acclaim and widespread use in public places.

Le design du canapé *Seam* est le résultat de notre envie de combiner une forme élégante et la pureté d'un volume unique pour un confort d'assise accru, mais sans les habituels coussins d'un canapé résidentiel. Le dossier et l'accoudoir très profonds plongent vers l'assise dans une courbe expressive, qui représente une solution ergonomique et qui fait également la griffe du canapé. La géométrie des courbes est accentuée par la couture et les surpiqûres. L'assise du canapé fusionne avec les accoudoirs et le dossier afin de créer un volume unique. Malgré la géométrie rigide réduite à l'essentiel, le canapé évoque des volumes organiques tel que le coquillage ou l'éventail. C'est peut-être cette ambivalence qui a fait le succès du canapé *Seam* et explique sa présence répandue au sein des espaces publics.

3SEATER / FABRIC
STEELCUT TRIO 2,
LEGS METAL COATED
CANAPÉ 3 PLACES
/ TISSUS STEELCUT
TRIO 2, PIÉTEMENT
MÉTAL LAQUÉ

177

SEAM

FRAME 5
SMALL TABLE / FRAME
METAL COATED, TABLE
TOP TEMPERED GLASS
TABLE BASSE /
STRUCTURE MÉTAL
LAQUÉ, PLATEAU
VERRE TRÉMPÉ

prostoría



3SEATER / FABRIC
STEELCUT TRIO 2,
LEGS METAL COATED
CANAPÉ 3 PLACES
/ TISSUS STEELCUT
TRIO 2, PIÉTEMENT
MÉTAL LAQUÉ

The design of the *Seam* sofa is the result of our efforts to integrate elegant form and the purity of a single volume for comfortable sitting, without cushions that are often reminiscent of residential settings.

Le design du canapé *Seam* est le résultat de notre envie de combiner une forme élégante et la pureté d'un volume unique pour un confort d'assise accru, mais sans les habituels coussins d'un canapé résidentiel.

BÖTTCHER HENSSLER KAYSER





Seven Bridges Genomics offices, New Belgrade, Serbia / Project: Antipod studio / Photo: Relja Ivanić



SEAM

183

2SEATER / 2 PLACES

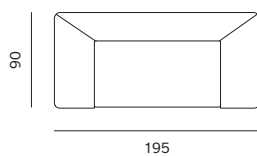

3SEATER / 3 PLACES

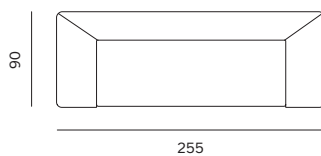

CORNER EXTENDED (L/R)
/ ANGLE PROLONGÉ (G/D)

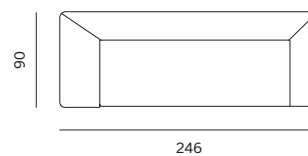

END UNIT (L/R)
/ MODULE ACCOUDOIR (G/D)

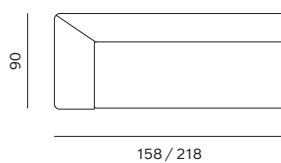

CHAISE LOUNGE (L/R)
/ MÉRIDienne (G/D)

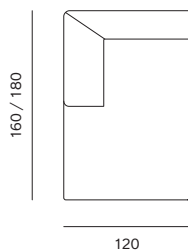

POUF
/ POUF

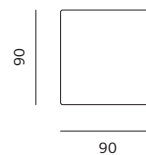

SEAM



INTERIOR INNOVATION AWARD 2015 WINNER
IF DESIGN AWARD 2015 WINNER
GOLDEN KEY AWARD 2016 WINNER

FRAME



The elementary forms of the *Frame* coffee table collection can have different characteristics depending on their colour, material or position in the space. Table tops with compact core or multi-coloured tempered glass are sunk into white or black thin metal frames. Grouped together or standing individually, the *Frame* coffee tables have a very wide range of uses and visual effects. Functioning as the central low table positioned next to a seating set or a coffee table used for putting things down, highlighted or discretely set in space, the *Frame* contributes to the use of space and the ambience in a variety of ways.

Les formes élémentaires de la collection des tables basses *Frame* peuvent avoir des caractéristiques différentes selon leur couleur, matière ou dimensions. Des plateaux en Compact Core ou en verre trempé de couleur s'encastrent à fleur dans des structures fines de métal blanc ou noir. En solo ou regroupées, les tables *Frame* offrent un large éventail de possibilités de mise en scène. En table basse centrale dans un coin salon, table d'appoint ou chevet, voir un ensemble pour exposer des objets d'art, *Frame* saura se rendre discrète ou prendre le devant de la scène.

FRAME 01
SMALL TABLE / TABLE BASSE

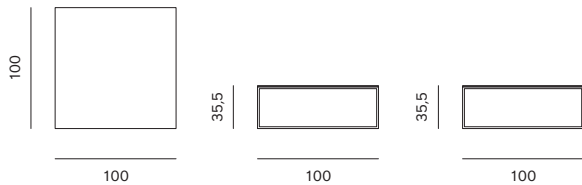

FRAME 02
SMALL TABLE / TABLE BASSE

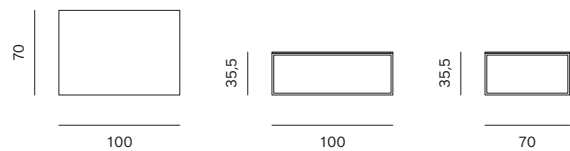

FRAME 03
SMALL TABLE / TABLE BASSE

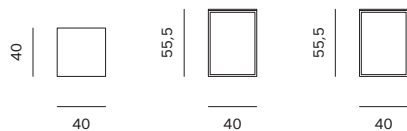

FRAME 04
SMALL TABLE / TABLE BASSE

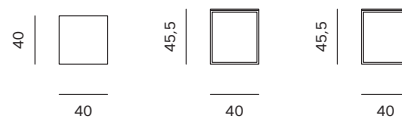

FRAME 05
SMALL TABLE / TABLE BASSE

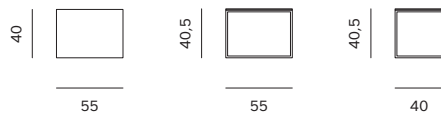

FRAME 06
SMALL TABLE / TABLE BASSE

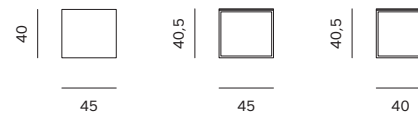

COMBO

From its very beginnings, **prostoria** explores themes of flexibility and transformability. The *Combo* set is our first step forward in this field – the three models, with or without the extended part, combine different functions: sitting, lying, playing and leisure... The unfolding procedure is simple, and the set includes a storage area. *Combo* is conceived as an extremely simply designed platform that can support different living scenarios, whereas its playfulness is complemented by the supplementary feather-stuffed soft cushions.

Depuis ses débuts **prostoria** explore les domaines de la flexibilité et la convertibilité. L'ensemble *Combo* est notre première exploration dans ce domaine. Les trois modèles, avec ou sans méridienne, permettent différentes utilisations; s'asseoir, s'allonger, jouer et se détendre... La manipulation pour convertir le canapé est facile et l'ensemble comporte un rangement pour le linge de lit. *Combo* est conçu comme un îlot proposant des scénarios de vie différents tandis que des coussins en plumes complètent l'ensemble.

2,5SEATER + EXT. /
FABRIC HALLINGDAL 65
2 PLACES + MÉRIDIENNE /
TISSUS HALLINGDAL 65

COMBO



FRAME 5
SMALL TABLE / FRAME
METAL COATED, TABLE
TOP TEMPERED GLASS
TABLE BASSE / STRUCTURE
MÉTAL LAQUÉ, PLATEAU
VERRE TRÉMPÉ

prostoría

***Combo* is conceived as an extremely simply designed platform that can support different living scenarios, whereas its playfulness is complemented by the supplementary feather-stuffed soft cushions.**

Combo est conçu comme un îlot proposant des scénarios de vie différents tandis que des coussins en plumes complètent l'ensemble.

PROSTORIA







BoShop, Aarhus, Denmark



prostorja Showroom, Sv Križ Začretje, Croatia / Photo: Vanja Šolin



COMBO

193

2,5SEATER + EXTENDED (L/R) / CANAPÉ 2,5 PLACES + MÉRIDienne (G/D)

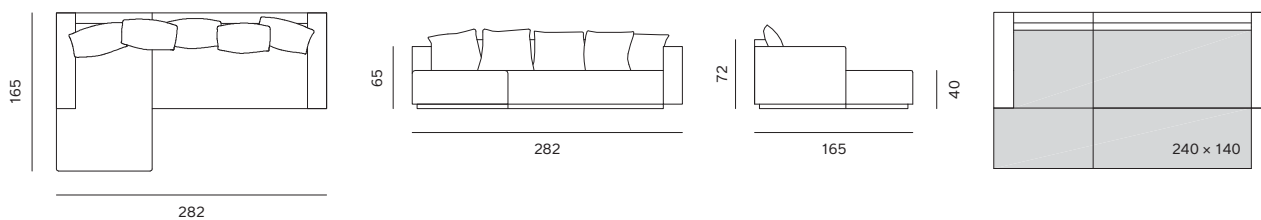

2SEATER + EXTENDED (L/R) / CANAPÉ 2 PLACES + MÉRIDienne (G/D)

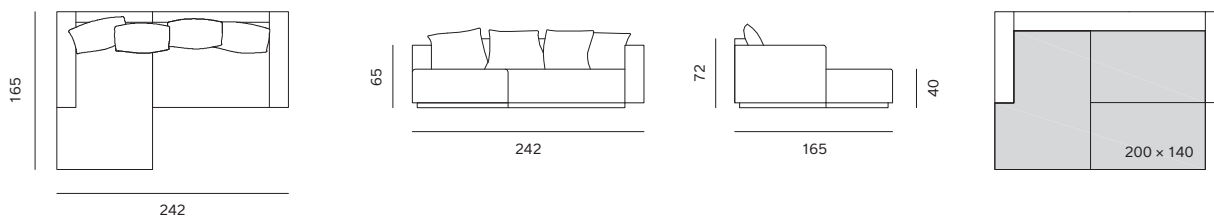

3SEATER SOFA / CANAPÉ 3 PLACES

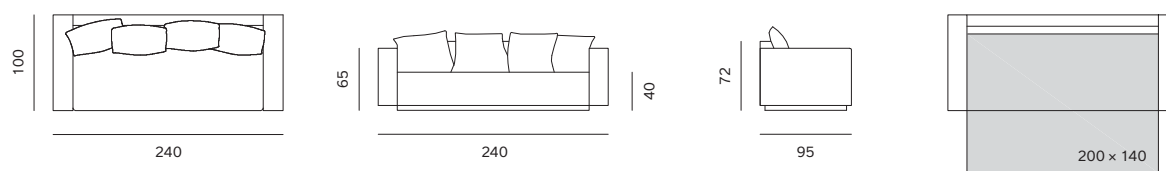

CHAISE LOUNGE (L/R) / MÉRIDienne (G/D)

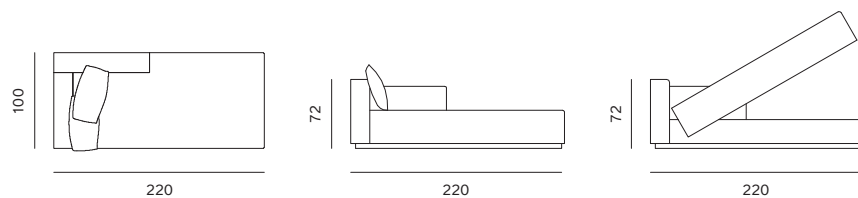

COMBO

UP-LIFT

DESIGN: REDESIGN



While designing the *Up-lift* armchair and sofa, our concept was to transform them into a bed with a single action. This action gives the impression of an elegantly orchestrated and rhythmical movement. By pulling the backrest forward, the side ends of circular armrests lean on the floor and serve as the eccentric rotation point around which the sofa easily opens into a functional bed. The attractive and contemporary form of the accentuated shape becomes pragmatically justified in almost surprising transformation and interaction with the user. The idea is original and unprecedented; this often tiresome action of unfolding an armchair or a sofa has been turned into a game that delights with its ingenuity. Such a solution rules out complicated mechanisms and constructions, at the same time maintaining a high level of comfortable sitting and lying. A very rare typology of an unfolding armchair is available with one and a half or double seats.

Lors de la conception du fauteuil et canapé *Up-Lift*, notre idée consistait à les convertir d'un seul geste. Ce geste donne l'impression d'un mouvement élégant orchestré et rythmé. En tirant le dossier vers l'avant, les accoudoirs, en s'appuyant sur le sol, deviennent le point de rotation excentré autour duquel le canapé se déploie facilement en lit fonctionnel. La ligne design prend tout son sens au moment la transformation interactive presque surprenante. L'idée est originale et sans précédent : cette action, souvent laborieuse, de déplier un fauteuil ou canapé devient un jeu délicieux par son ingéniosité. Ce type de solution met fin à des mécanismes compliqués tout en gardant un confort d'assise et de couchage. Le *Up-lift* existe en version une place, une place et demie et deux places.



ARMCHAIR /
FABRIC REMIX
FAUTEUIL /
TISSUS REMIX

While designing the *Up-lift* armchair and sofa, our concept was to transform them into a bed with a single action. This action gives the impression of an elegantly orchestrated and rhythmical movement.

Lors de la conception du fauteuil et canapé *Up-Lift*, notre idée consistait à les convertir d'un seul geste. Ce geste donne l'impression d'un mouvement élégant orchestré et rythmé.

REDESIGN

2SEATER /
FABRIC ERA
2 PLACES /
TISSUS ERA



ARMCHAIR /
FABRIC REMIX
FAUTEUIL /
TISSUS REMIX



OBLIQUE
SMALL TABLE /
TABLE TOP
FENIX NTM,
LEGS OAK LIGHT
TABLE BASSE /
PLATEAU FENIX
NTM, PIÉTEMENT
CHÈNE CLAIR





Hotel Navis Opatija, Croatia
Project: Idis Turato
Photo: Bosnić+Dorotić



200

UP - LIFT

2017

UP-LIFT

201

UP - LIFT



CLOSED ARMCHAIR
/ FAUTEUIL FERMÉ

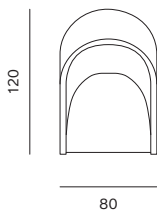

CLOSED 1,5SEATER
/ 1,5 PLACES FERMÉ

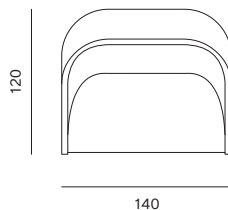

CLOSED 2SEATER
/ 2 PLACES FERMÉ

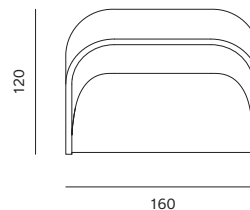

OPENED ARMCHAIR
/ FAUTEUIL OUVERT

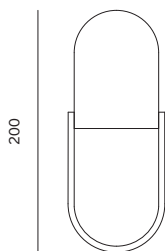

OPENED 1,5SEATER
/ 1,5 PLACES OUVERT

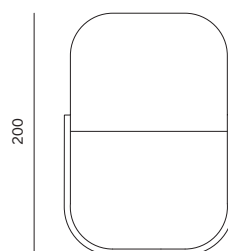

OPENED 2SEATER
/ 2 PLACES FERMÉ

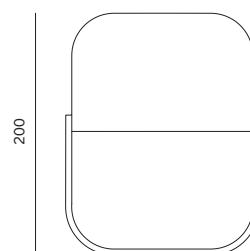

INTERIOR INNOVATION AWARD 2014 WINNER
GERMAN DESIGN AWARD 2015 SPECIAL MENTION

REVOLVE

DESIGN: NUMEN/FOR USE, BOROVNJAK & BRATOVIĆ



Our design of the sofa that transforms into the bed is based on our previous experience when we realized that complicated mechanisms do not really function in the long run. That is why we focused on the search for the simplest unfolding method possible. We have created a system with which the backrest rotates at 180 degrees around the seat and becomes part of the bed. The open bed form is symmetrical and fits well independently in the space. The form of this position is equally balanced as the position of a folded sofa, which is often not the case with folding furniture. Just like with mono-functional mattresses, the quality of relaxation is equally distributed along the width owing to the construction made from cold foam and applied on both blocks. **prostoria's** expertise in cold foam technology was a very valuable contribution in the process of reaching that functional goal. We highlighted this basic, almost banal unfolding method with a leather handle so that the user accepts the way the sofa functions almost instinctively.

Le design du canapé convertible *Revolve* est basé sur notre expérience des mécanismes compliqués qui ne tiennent pas dans la durée. Pour cette raison nous nous sommes concentrés sur la recherche d'un mode de conversion le plus simple possible. Nous avons créé une conversion par une rotation de 180° du dossier autour de l'assise, et qui devient partie intégrante de la surface de couchage. La version nuit déploie une symétrie bi-axiale et tient sa place en tant qu'objet design à part entière. *Revolve* déplié est visuellement aussi équilibré qu'en version repliée, ce qui est rarement le cas des canapés convertibles classiques. La qualité de soutien est égale à un matelas classique et est répartie de façon égale sur toute la largeur grâce à l'utilisation de mousse froide sur les deux blocs. L'expertise de **prostoria** au niveau de la technologie de la mousse froide a contribué de façon significative à l'obtention de ce résultat. Nous avons souligné le déploiement presque enfantin, par une poignée en cuir rendant la manipulation quasi intuitive pour l'utilisateur.

SOFABED /
FABRIC SYNERGY
CANAPÉ CONVERTIBLE /
TISSUS SYNERGY

REVOLVE



prostoría

We have created a system with which the backrest rotates at 180 degrees around the seat and becomes part of the bed. The open bed form is symmetrical and fits well independently in the space.

Nous avons créé une conversion par une rotation de 180° du dossier autour de l'assise, et qui devient partie intégrante de la surface de couchage. La version nuit déploie une symétrie bi-axiale et tient sa place en tant qu'objet design à part entière.

NUMEN/FOR USE
BOROVNJAK & BRATOVIĆ



POLYGON
SMALL TABLE
/ LEGS METAL
COATED BLACK,
TABLE TOP
FENIX NTM
TABLE BASSE /
PIÉTEMENT MÉTAL
LAQUÉ, PLATEAU
FENIX NTM







Studio Scenography, Zagreb, Croatia / Photo: Domagoj Kunić



REVOLVE



3SEATER SOFA / CANAPÉ 3 PLACES

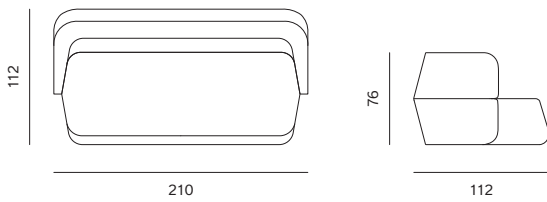

SOFABED / COUCHAGE

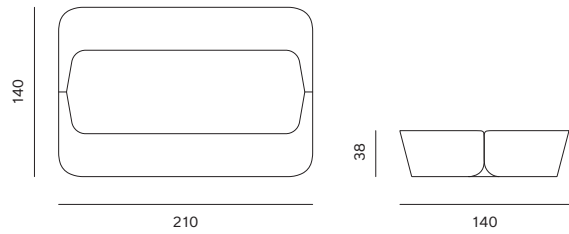

POUF / POUF

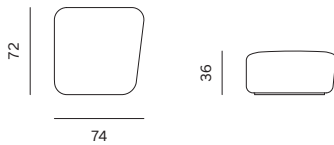

RED DOT DESIGN AWARD 2012 WINNER

PIL-Low

DESIGN: REDESIGN



While designing the *Pil-low*, we focused our research on the most effective transformation from a sofa into a bed. This transformation functions like a simple spatial puzzle. In the closed position, between the volume of the seat and the backrest, there is a hard triangular pillow that adds to the quality of sitting. The sofa opens when entirely lifted forward and rotated around the sub-structure, hiding space for storing bed linen. The backrest is then rotated backwards and the emerging gap is used for storing the pillow. With this system, all elements of the sofa are put to use as an expanded sleeping platform. Opening and closing of the sofa is optimized without a single superfluous element: all elements fall into their place. This ingenious *transformer* is marked with precise geometry and remarkable presence with playful colours of stitching and legs.

Lors de la création du *Pil-low* nous nous sommes concentrés sur la manière la plus efficace de convertir un canapé en lit. Sa conversion fonctionne comme un simple puzzle spatial. Un long coussin lombaire est calé entre le dossier et l'assise dans la position fermée, améliorant le confort de l'assise. Le canapé se convertit par une élévation de l'ensemble puis une rotation au tour de la sous-structure, découvrant un espace de rangement pour le linge de lit. Par la suite le dossier est basculé en arrière et l'espace restant entre l'assise et le dossier est comblé par le coussin lombaire, créant ainsi une plateforme de couchage étendue. L'ouverture et la fermeture du canapé sont optimisées sans aucun élément superflu, chaque élément retrouve sa place dans les deux configurations. Ce canapé transformiste se démarque par sa géométrie précise et sa présence remarquable, soulignée par les couleurs ludiques des surpiques et du piétement.



3SEATER / FABRIC
CANVAS, LEGS
METAL COATED
CANAPÉ 3 PLACES /
TISSUS CANVAS,
PIÉTEMENT
MÉTAL LAQUÉ



Opening and closing of the sofa is optimized without a single superfluous element: all elements fall into their place.

L'ouverture et la fermeture du canapé sont optimisées sans aucun élément superflu, chaque élément retrouve sa place dans les deux configurations.

REDESIGN

3SEATER / FABRIC
CANVAS, LEGS
METAL COATED
CANAPÉ 3 PLACES /
TISSUS CANVAS,
PIÉTEMENT
MÉTAL LAQUÉ





Private apartment New York, USA
Project: Studio Esnal / Photo: Miguel de Guzman / Imagen Subliminal



FABRIC
/ TISSUS
CLARA 2

214

PIL-LOW

2017



PIL-LOW

215



PIL-Low

3SEATER SOFA / CANAPÉ 3 PLACES

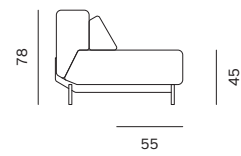
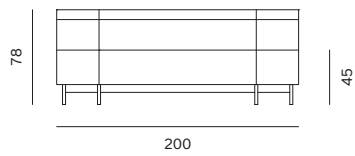
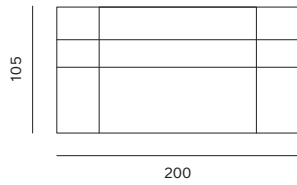

SOFA BED / COUCHAGE

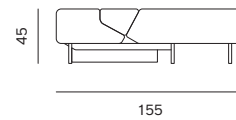
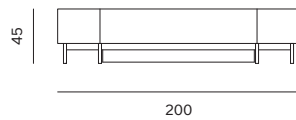
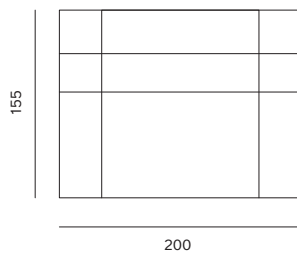

SIMETRIA

DESIGN: REDESIGN



Being composed of a single element, i.e. massive oak sticks, *Simetria* was a challenging task for us, implying the quest for an expressive impression combined with the functionality derived from minimum means. The coat stand is symmetrical on both axes but its appearance changes depending on the perspective: from a serene mathematical sculpture to a vibrant and almost disorganized composition. *Simetria* is very practical: it is delivered in a flat pack, easy to assemble and has seamless joints. A relatively prosaic typology has been transposed into the pleasure of designing.

Etant composé d'un seul élément, des tasseaux en chêne massif, *Simetria* était un défi pour nous, requérant la quête d'une impression visuelle expressive combinée avec une fonctionnalité acquit par un minimum de moyens. Le porte-manteau est symétrique sur les 2 axes mais son apparence change, selon la perspective de l'observateur, d'une sculpture symétrique sereine à une composition quasi désorganisée et vibrante. *Simetria* est d'autant plus pratique, qu'il est livré en paquet plat, facile à assembler avec des raccords sans joint. Un objet habituellement plutôt ennuyeux a été converti en un délice de création.

217

SIMETRIA

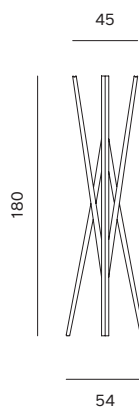
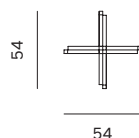

NUMEN/FOR USE



Numen/ForUse (Sven Jonke, Christoph Katzler, Nikola Radeljković) is a Croatian-Austrian design collective working in the fields of scenography, industrial and spatial design and conceptual art. Under the banner ForUse they designed for Cappellini, ClassiCon, Desalto, Interlubke, Magis, MDF Italia, Moroso and Zanotta. Numen/ForUse are the only Croatian contemporary product designers whose works

are regularly represented in global anthologies of contemporary design.

Numen/ForUse (Sven Jonke, Christoph Katzler, Nikola Radeljković) est un collectif de design présent dans les domaines de la scénographie, le design d'espace et design industriel, ainsi que l'art conceptuel. Sous la bannière de ForUse, ils ont créé pour Cappellini, ClassiCon, Desalto, Interlubke, Magis, MDF Italia, Moroso and Zanotta. Numen/ForUse sont les seuls designers contemporains croates dont les créations apparaissent régulièrement dans les anthologies du design mondial.

GRUPA



Members of *Grupa* are designers Filip Despot, Ivana Pavić and Tihana Taraba. For a number of years, they have been collaborating with Croatian and foreign furniture producers and since 2010 they have started developing their own brand named the *Grupa products*, which are distributed on the international and European markets. They have been exhibiting on domestic and international juried

exhibits and their works were published in important international and Croatian publications. They have also been awarded many prizes.

Les membres de *Grupa* sont les designers Filip Despot, Ivana Pavić et Tihana Taraba. Depuis quelques années, ils collaborent avec des producteurs de mobiliers croates et étrangers et ils ont commencé à développer leur propre marque sous le nom de *Grupa Products* à partir de 2010. Leurs produits sont distribués sur le marché européen et mondial. Ils ont exposé sur des expositions de concours nationaux et internationaux et leurs travaux ont été publiés dans de nombreuses publications croates et internationales. Ils ont également reçu de nombreux prix.

SANJA KNEZOVIĆ



Sanja Knezović is primarily an architect who heads her own architectural studio, which specializes in private houses and smaller commercial buildings. She has transferred the experience gained from designing furniture units for interiors onto designing upholstered furniture for **prostorija**, her first project in the field of product design.

Sanja Knezović est avant tout une architecte dirigeant son

propre bureau d'architecte, spécialisé dans les résidences privés et petits immeubles commerciaux. Elle a mis à profit l'expérience acquise lors de la création des éléments d'agencement d'intérieur pour créer du mobilier rembourré pour **prostorija**, son premier projet dans le domaine du design produit.

REDESIGN



Redesign is a multidisciplinary design studio focusing on the development of concepts for new products and technological innovations. Owing to their knowledge of various technological fields, they have realized a wide range of projects, from the design for recycled cardboard shelves to a sophisticated device used in rehabilitation, testing and training of the knee joint. In their work, the

team strives for comprehensive solutions that represent the synthesis of all disciplines in the sphere of design.

Redesign est un studio de design multidisciplinaire se concentrant sur le développement de concepts de produits nouveaux et d'innovations techniques. Ils ont réalisé un large éventail de produits grâce à leurs connaissances dans des domaines technologiques variés ; création d'étagères en carton recyclé, un appareil ingénieux utilisé dans la rééducation et réadaptation de l'articulation de genou. Dans leur travail, l'équipe aspire à trouver des solutions complètes qui constituent la synthèse de toutes les disciplines dans le domaine du design.

SIMON MORASI PIPERČIĆ



Established in 2013, Simon Morasi Piperčić is a Zagreb-based design office working on various projects ranging from product, furniture, spatial design and installation to art direction and strategic consultancy. The office has been granted with some of the most highly considered awards – The German Design Award in 2017, twice Red Dot in 2013 and 2015 and Interior Innovation Award in 2015. In 2014, they

were a part of the team that designed the Croatian pavilion at the Venice architecture biennale. Their work was published in several renowned magazines (*Dezeen, Domus, Frame, Designboom* etc.) and exhibited worldwide.

Etabli en 2013, Simon Morasi Piperčić est un studio de design basé à Zagreb et qui travaille sur des projets variés allant du produit, mobilier, design et installation d'espace à la direction artistique et le conseil stratégique. Le prix les plus prestigieuses ont été accordés au studio ; le German Esign Award 2017, deux fois le Red Dot Award en 2013 et 2015 et le prix Interior Innovation Award en 2015. En 2014, ils faisaient parti de l'équipe qui crée le pavillon croate de la Biennale d'architecture de Venise. Leurs travaux ont été publiés dans plusieurs magazines de renommés (*Dezeen, Domus, Frame, Designboom* etc.) et exposé dans le monde entier.

BÖTTCHER HENSSLER KAYSER



Moritz Böttcher and Sören Henssler founded their Berlin based design studio in 2007. In 2013 the designer Nikolaus Kayser joined the team. Since 2014 the trio is working under the studio name Böttcher Henssler Kayser in the fields of consumer product, furniture and lighting design with companies such as ANTA, Böwer, Mater, Normann Copenhagen, Scantex, Schönbuch, Vertigo Bird

and Zero. The designers were honoured with a number of distinctions like iF and red dot design awards, the prestigious red dot „best of the best“ and the Interior Innovation Award 2015 for their sofa Seam produced by **prostor**ia

Moritz Böttcher et Sören Henssler ont fondé leur studio de design en 2007. En 2013 le designer Nikolaus Kayser les rejoint. Depuis 2014 le trio travaille sous le nom de studio Böttcher Henssler Kayser dans les domaines de produit consommateur, mobilier et luminaires avec des sociétés comme ANTA, Böwer, Mater, Normann Copenhagen, Scantex, Schönbuch, Vertigo Bird et Zero. Les designers ont été honorés de nombreux prix comme le prix IF et le prix Red Dot Design Awards, la prestigieuse « Best of the Best » et le prix Interior Innovation Award 2015 pour leur canapé Seam produite chez **prostor**ia.





prostorja Ltd
Pustodol Začreški 19g
49223 Sveti Križ Začretje
Croatia

t +385 49 200 555
f +385 49 200 556
e info@prostorja.eu
www.prostorja.eu

All inquiries international markets:

t +385 49 200 555
f +385 49 200 556
e export@prostorja.eu

prostorja ltd
Pustodol Začreški 19g
49223 Sveti Križ Začretje
Croatie

t +385 49 200 555
f +385 49 200 556
e info@prostorja.eu
www.prostorja.eu

Tout renseignements marchés internationaux

t +385 49 200 555
f +385 49 200 556
e export@prostorja.eu

PUBLISHER
prostorja Ltd

TEXT
Maroje Mrduljaš
designers
prostorja

ART DIRECTION / SET DESIGN
/ GRAPHIC DESIGN / LAYOUT
Bilić_Müller Studio

LAYOUT / CO - WORKER
Negra Nigoević

COVER ILLUSTRATIONS
Danijel Srdarev

TEXTILE INSTALLATION
Ivana Zozoli, Bilić_Müller Studio

PHOTOGRAPHY
Vanja Šolin (Proces 15)

PHOTOGRAPHY PROCESSING
Iron&ja

TRANSLATION
Mirna Herman Baletić

PROOFREADING
Maja Trinajstić

PRINTED BY
Printera, Zagreb

EDITEUR
prostorja ltd

TEXTE
Maroje Mrduljaš
designers
prostorja

DIRECTION ARTISTIQUE / MISE EN SCÈNE
/ CRÉATION GRAPHIQUE / MISE EN PAGE
Bilić_Müller Studio

COLLABORATEUR MISE EN PAGE
Negra Nigoević

ILLUSTRATIONS COUVERTURE
Danijel Srdarev

MISE EN SCÈNE
Ivana Zozoli, Bilić_Müller Studio

PHOTOGRAPHIE
Vanja Šolin (Proces 15)

RETOUCHES PHOTO
Iron&ja

TRADUCTION
Irma van Liempd

RELECTURE
Ivana Pogačić

IMPRIMÉ PAR
Printera, Zagreb

PROPS / ACCESSOIRES

Marina Badurina
bilić_müller studio
Lidia Boševski, Atelier Owl
Grupa Products
Havranek+Lugonja
Oaza
Danijel Srdarev
Sanja Mrša Vukman

THIS BROCHURE IS FOR INFORMATIONAL PURPOSES ONLY AND IT IS MADE IN ACCORDANCE WITH THE INFORMATION AT THE TIME OF PRINTING. DEVIATIONS OF ±3 CM IN PRODUCT DIMENSIONS ARE POSSIBLE. WE ARE NOT RESPONSIBLE FOR ANY PRINTING ERRORS, SUBSEQUENT PRODUCT CHANGES OR IMAGE FIDELITY. WE KINDLY ASK YOU TO CONTACT OUR AUTHORISED SALES OUTLETS FOR ALL QUERIES REGARDING PRODUCT CHARACTERISTICS AND APPEARANCE, AND ANY ADDITIONAL OR NEW INFORMATION REQUIRED FOR REACHING A FINAL PURCHASE DECISION.

ALL RIGHTS RESERVED.
© 2017 PROSTORIA LTD

CE CATALOGUE N'EST QU'INFORMATIF ET COMMUNIQUE LES INFORMATIONS DISPONIBLES AU MOMENT DE L'IMPRESSION. DES ÉCARTS DES DIMENSIONS DES PRODUITS DE PLUS OU MOINS DE 3CM SONT POSSIBLES. NOUS NE SOMMES PAS RESPONSABLES DES ERREURS D'IMPRESSION, DES CHANGEMENTS DE PRODUITS ULTÉRIEURS OU DE LA FIDÉLITÉ DE L'IMAGE. NOUS VOUS INVITONS DE VOUS RAPPROCHER DE NOS AGENTS AGRÉÉS POUR TOUTE QUESTION CONCERNANT LES CARACTÉRISTIQUES ET L'ASPECT VISUEL DU PRODUIT, AINSI QUE TOUTE INFORMATION SUPPLÉMENTAIRE OU NOUVELLE NÉCESSAIRE À LA FINALISATION DE L'ACHAT.

TOUS DROITS RÉSERVÉS
© 2017 PROSTORIA D.O.O.



www.prostoria.eu