

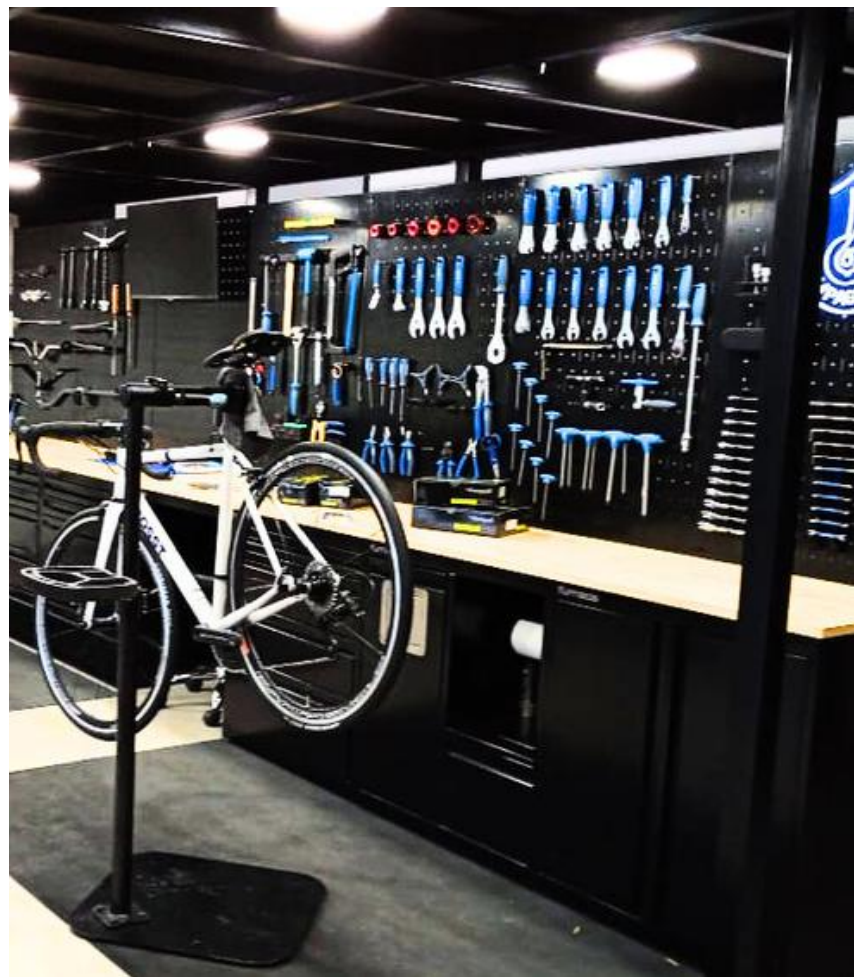

**Go Lean.
Gain Efficiency.
Make Profits.**

with Furnisys's

Functional Furniture Systems.



ABOUT FURNISYS

Our solutions help companies enhance their lean management practices while integrating the principles of an ergonomic design to create a balanced work environment.

Furnisys offers a complete range of metal based workspace furniture systems.

It consists of workbenches, workstands, cabinets, trolleys, carts, flow racks.





CONTENTS

Why Furnisys	01
Our Value Chain	03
Making Lean More Human	05
Application	07
Our Approach	09
Product Portfolio	11
Clientele	13

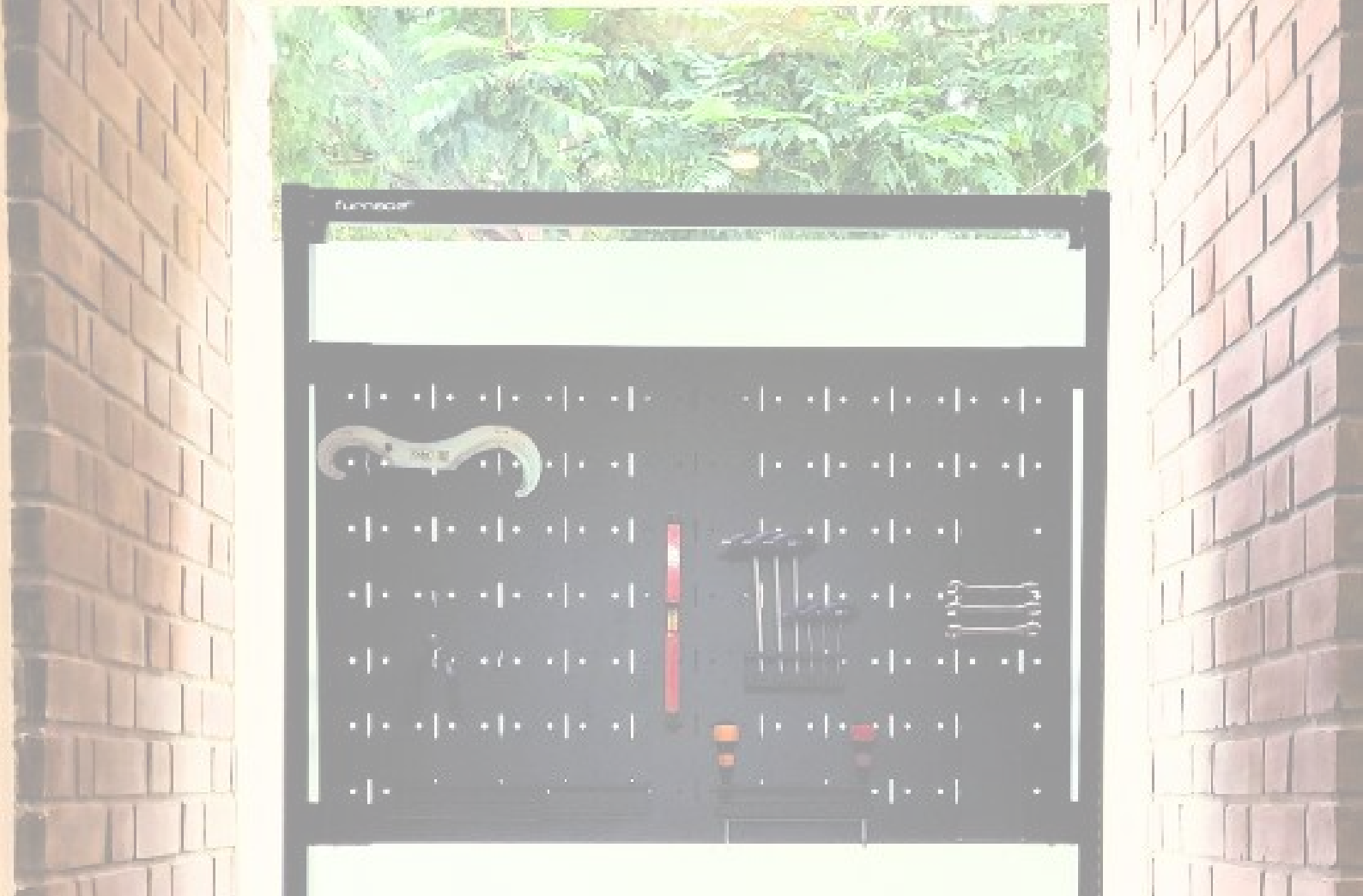

WHY FURNISYS ?



At Furnisys, we aim to improve the quality of workspaces which in turn exponentially boosts the efficiency and bottom line of the company. Our systems help you enhance your workspaces dynamics through:

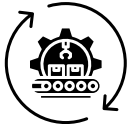

Lean Manufacturing

Improve productivity by combining lean initiatives with value stream mapping and 5S with our solution



The System Concept

All products can be freely integrated & combined



Custom Play

For customers with specific needs

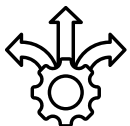

Maximum Flexibility

With choice of colours, configuration options & more



Buying Guide

Selection guides, Product Comparisons, Case Studies, Reference Work Gallery



Ergonomics

Product designs helps to minimize injuries & help maximize productivity

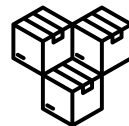

Comprehensive Range

Multiple product options for your operational needs



Expert Planning

with 3D modeling visualization software



Wide Range of Service

Such as Installation, After-sales support etc.



Made in INDIA

Committed to manufacturing highest quality of metal based industrial furniture in INDIA

Our Value chain

Engineering Design

Value Addition, R&D

Project Management

Individualized attention, time-sensetive

Manufacturing

40+ years experience, Agile methodology

Sales & Marketing

Empathetic approach, Authenticity

Infrastructure:

Furnisys is supported by multiple self-owned factories located in over 25,000 sq.ft. in Navi Mumbai. Manufacturing all products in-house provides us with the opportunity to control 100% of the product quality and ability to facilitate projects of all sizes while maintaining competitive pricing and outstanding lead times. All of the factories feature the latest machinery and technology available to use.

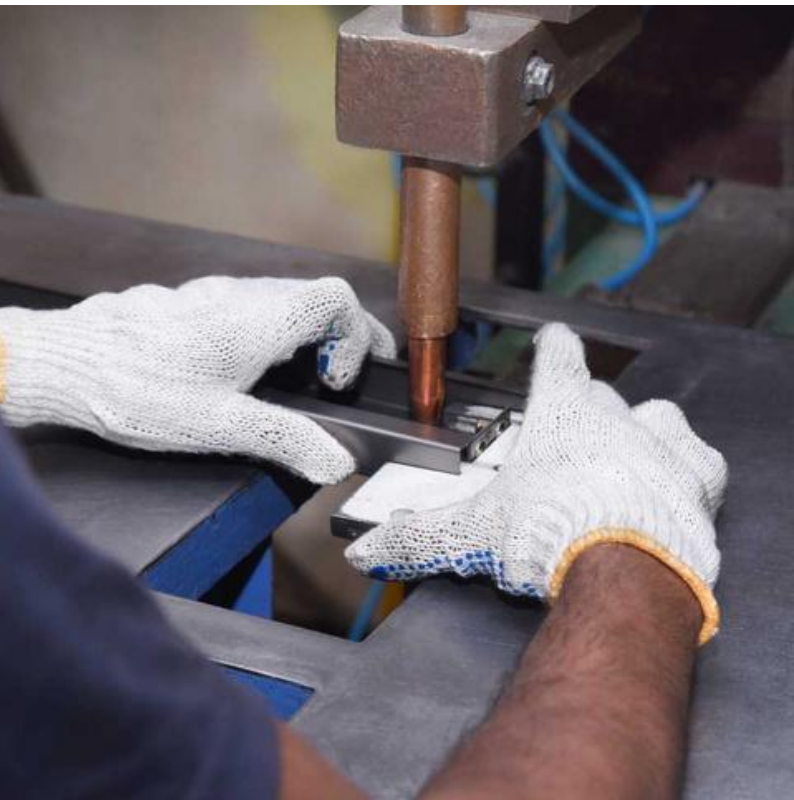

Making Lean More Human

By working together, these two principles can make the workplace more efficient and safe, eliminating waste and reducing risk for your employees.

Lean Thinking

Lean is a way of thinking about creating needed value with fewer resources and less waste. It always starts with the customer. What does the customer value? What problem does the customer need to solve?

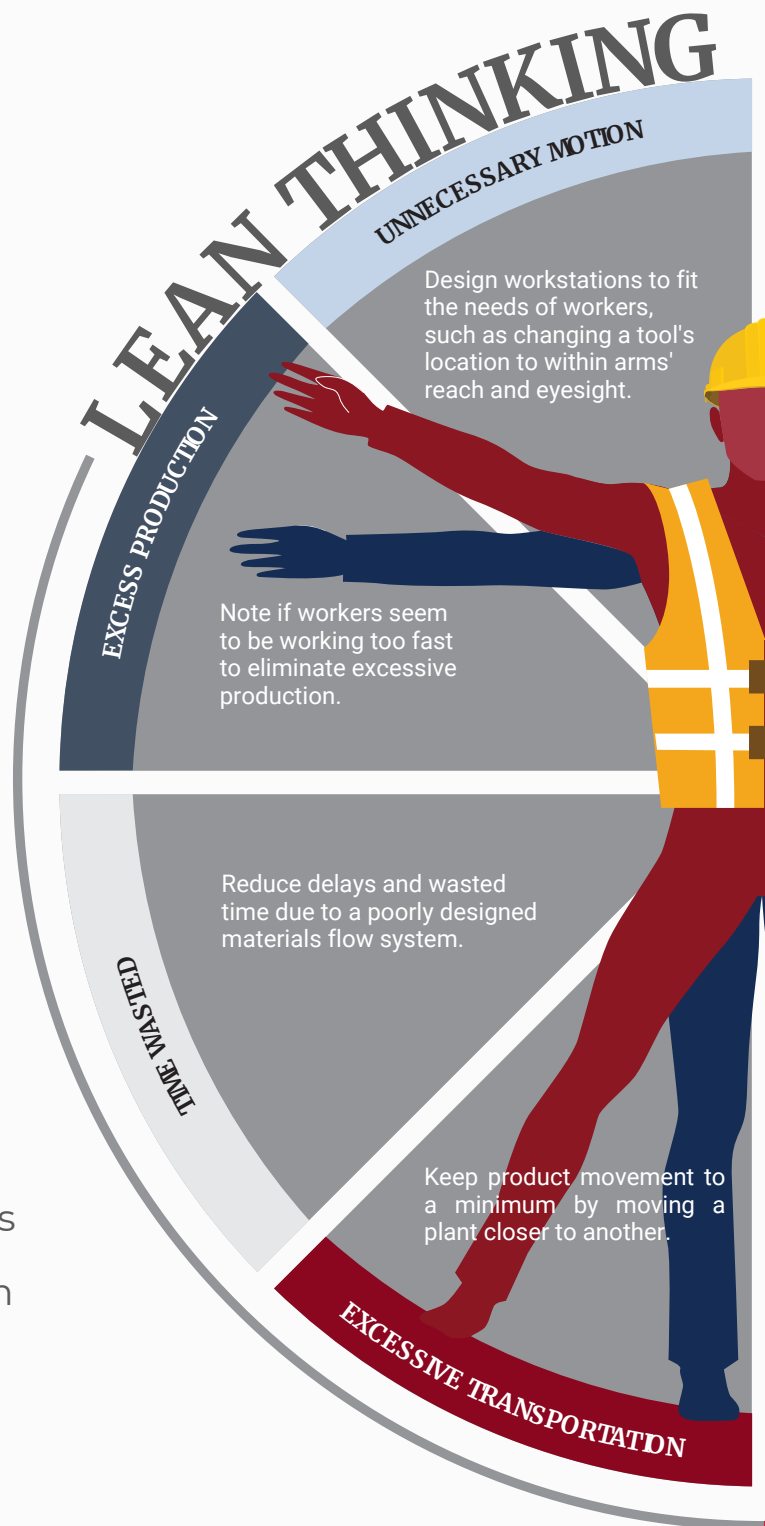

Lean-pushing production efficiencies and ergonomics are two seemingly unrelated fields. However, Lean thinking and Ergonomics go hand in hand-each field impacting the other.

Both can combine to make manufacturing more efficient, profitable, and sustainable.



Ergonomics

The word ergonomics comes from the Greek word “ergonomic” which means work and “nomos” which means laws. Good ergonomic design removes incompatibilities between work and worker and creates an optimal work environment.

Application

Furnisys system can develop a custom fit, integrated solution to the industries, spaces and application scenarios of every project.

Assembly Area

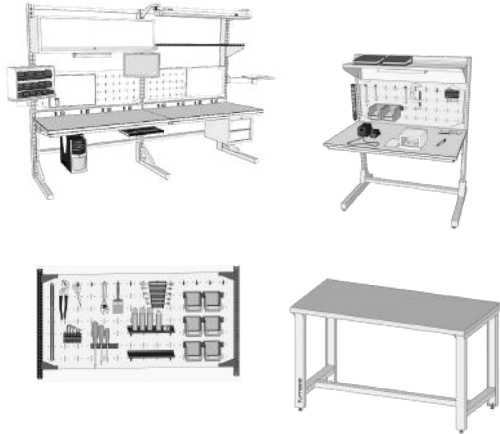

Workstation, heavy duty workbenches, pegboards, carts to adapt to multiple function & changes in workflow with high level of ergonomic comfort

File Storage room

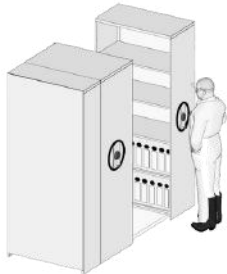

Mobile shelving units which helps in efficiently utilizing floor space to store files

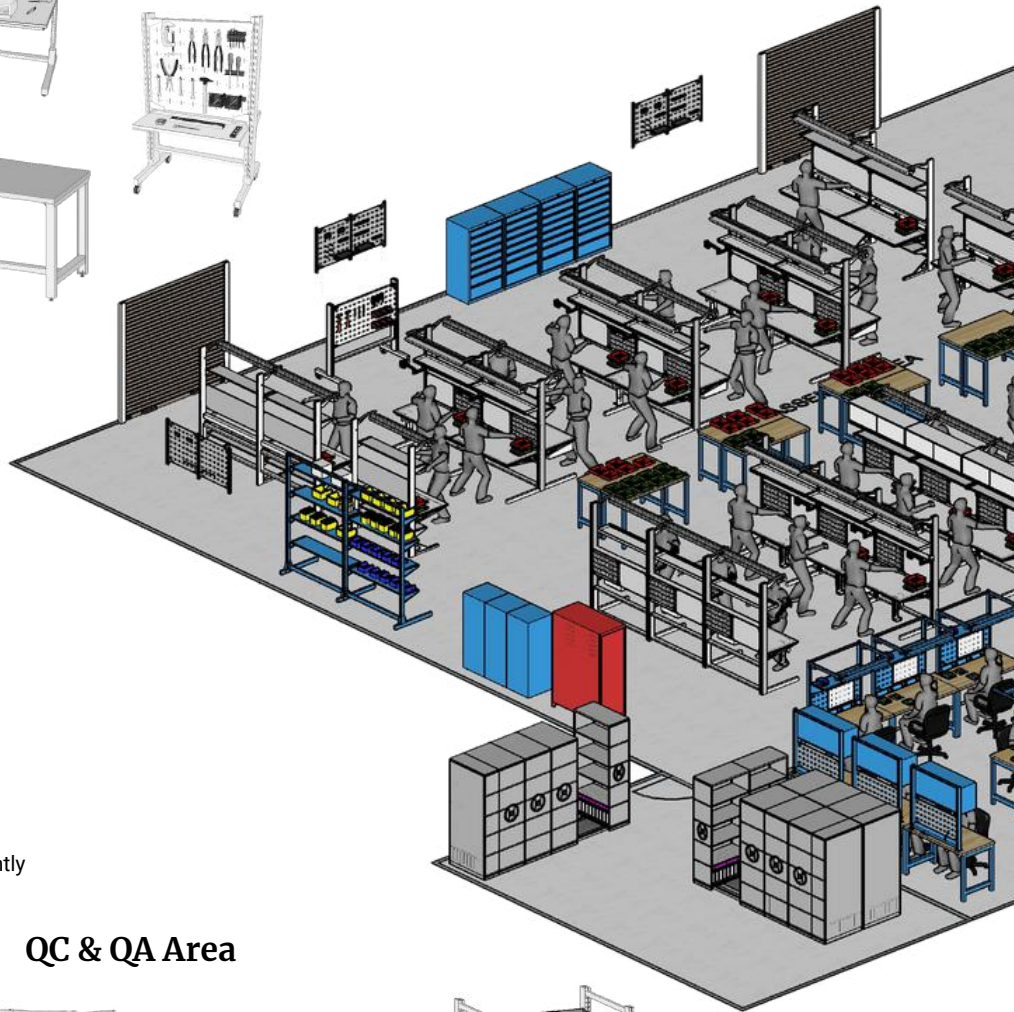

QC & QA Area

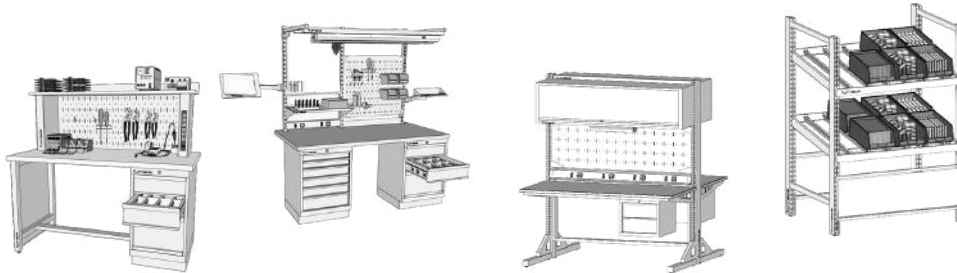

Workbenches with practical work surface materials & accessories to increase efficiency & facilitate sustainability

Industries

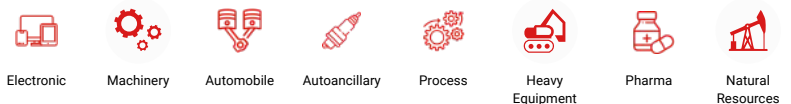

Packing Area

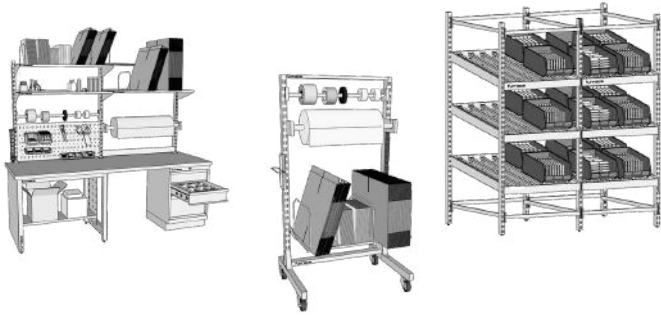

Packaging workstation, Trolleys & flowracks are flexible to accommodate your need for packaging

Maintenance Area

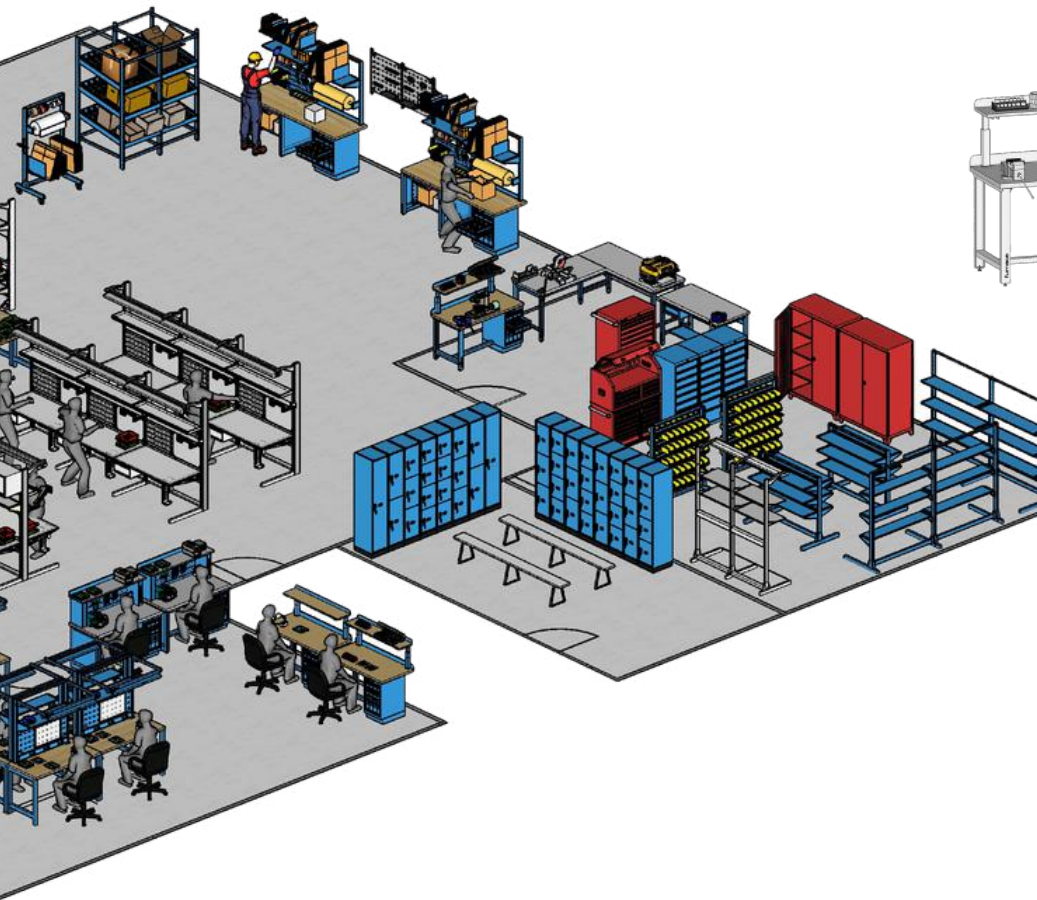

Wide selection of configurable workstations & above worksurface accessories for heavy duty application

Store room

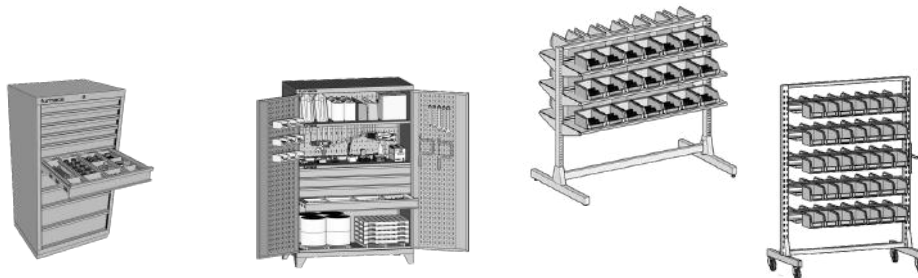

Our wide range of stand, base, mobile & tall cabinet helps to store bulky & small items in one system



Aerospace



Assembly



Gem & Jewellery



Chemical



Packaging



Mining



Agriculture



Utilities

Our Approach

We strive to add value at every step our buyer's business journey. Being fully aware of the versatile stages that our buyer goes through, our team focuses on empowering its buyers at their pace.



1

Free Consultation



- Talk with our technical experts
- ROI analysis and justification
- Product configuration, project alignment and budget planning



2

Planning Competency



- Techno-commercials delivered within 48 hours*
- 3D and 2D Product Visuals
- 2D Space Visuals

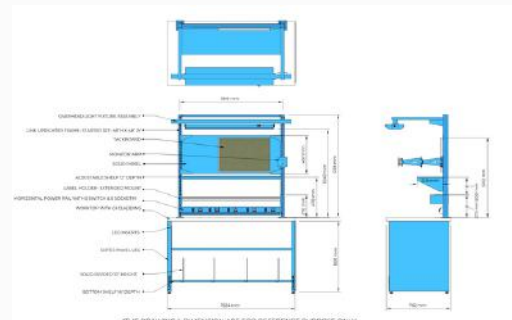
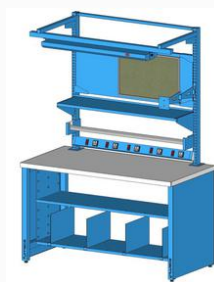
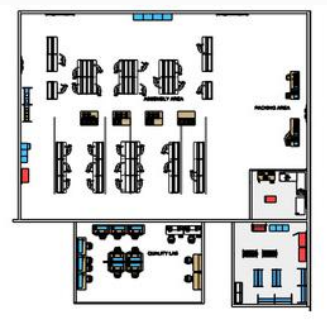

*Subject to change based on requirements

CLIENTELE



3

Efficient Delivery



- Manufactured within 4 weeks*
- Engineered and manufactured in-house



4

Professional Installation



- The Perfect Finish
- Easy to follow assembly instructions
- Self Assembly Friendly



*Subject to change based on requirements

Product Portfolio

Furnisys offers a diverse range of products designed to bring a perfect balance within space, operation and workers needs.

Workbenches & Workstations

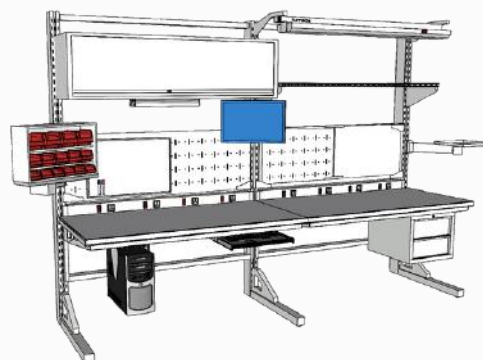
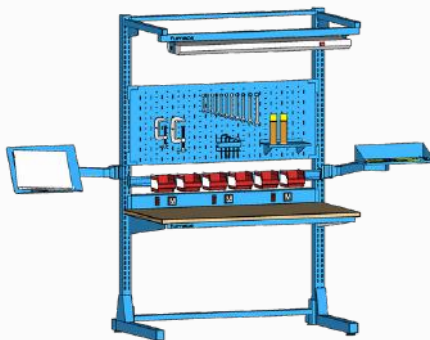
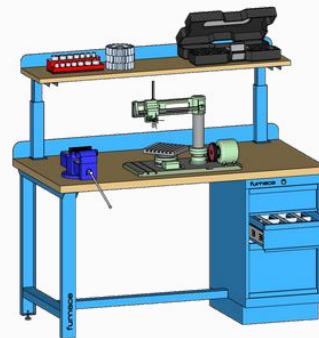
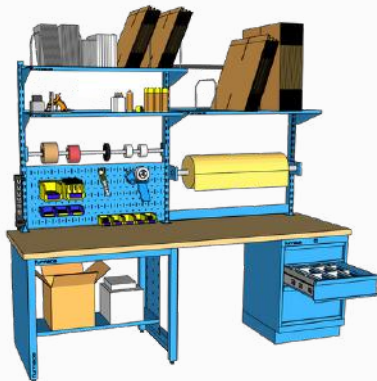

Trolleys, Carts & Flow Racks



Cabinets, Pegboard

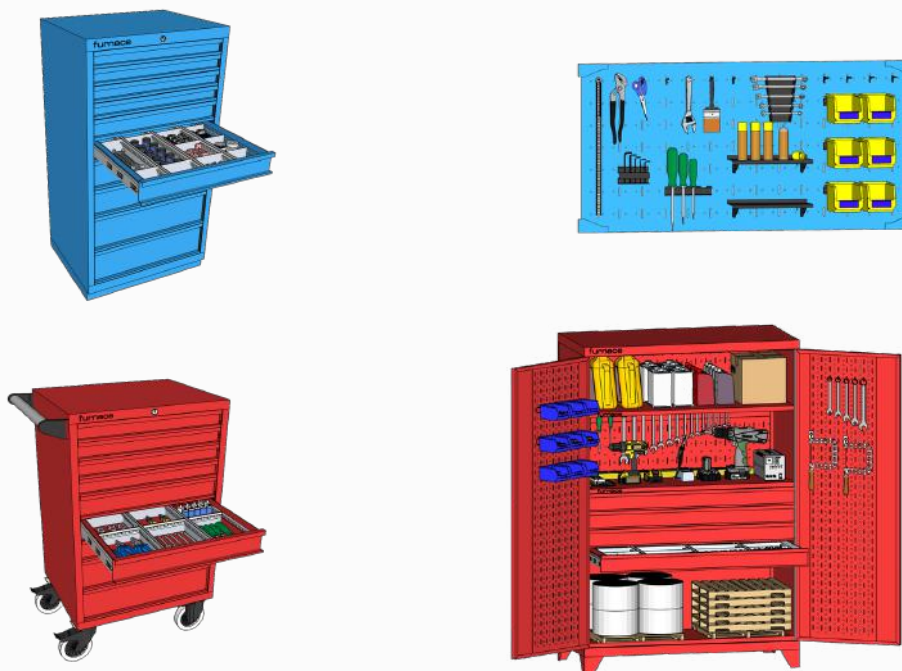

CLIENTELE

adani™



SAINT-GOBAIN

atomberg

Smith+Nephew

SHIMANO®

ador
peace of mind™

Continental
The Future In Motion

LIEBHERR

POWERMASTER
BUILT TO LAST

SUNFLAG
STEEL

PRINCE
INDUSTRIES



DELUX
BEARINGS
INSPIRING EVERY MOVEMENT



SELEC®
Creating Best Value

MAXCESS®

SP ULTRAFLEX
SYSTEMS (P) LIMITED
Make OUR EXPERIENCE work to YOUR ADVANTAGE

ITALTINTO

KOHLER®

Gardner
AEROSPACE

Dräger

PARAS DEFENCE & SPACE
TECHNOLOGIES LIMITED

KOHLI

THRIVENI

Sero

EMCO
ELECTRONICS
Power to Transform

kritsnam

MARQUARDT

+GF+
GEORG FISCHER
PIPING SYSTEMS

POSST



NOV

FBE
INDIA
a brilliant biomedical blend

EL-21 TTC Industrial Area, Mahape,
Navi Mumbai - 400 710
+ 91 7045763012
sales@furnisys.co

www.furnisys.co
furnisys.co / @ LinkedIn Facebook

