

# BESTRONG

 bestrongworld  bestrongworld  usa.bestrong.com  usa@bestrong.com

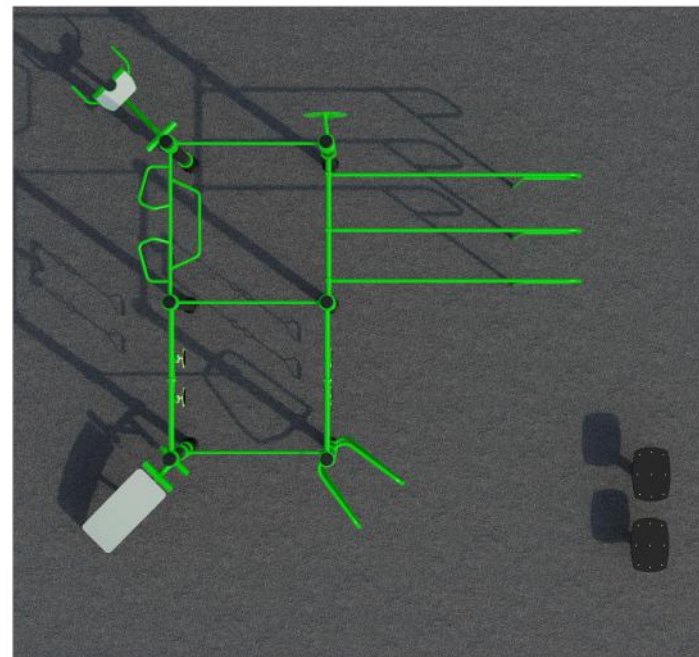
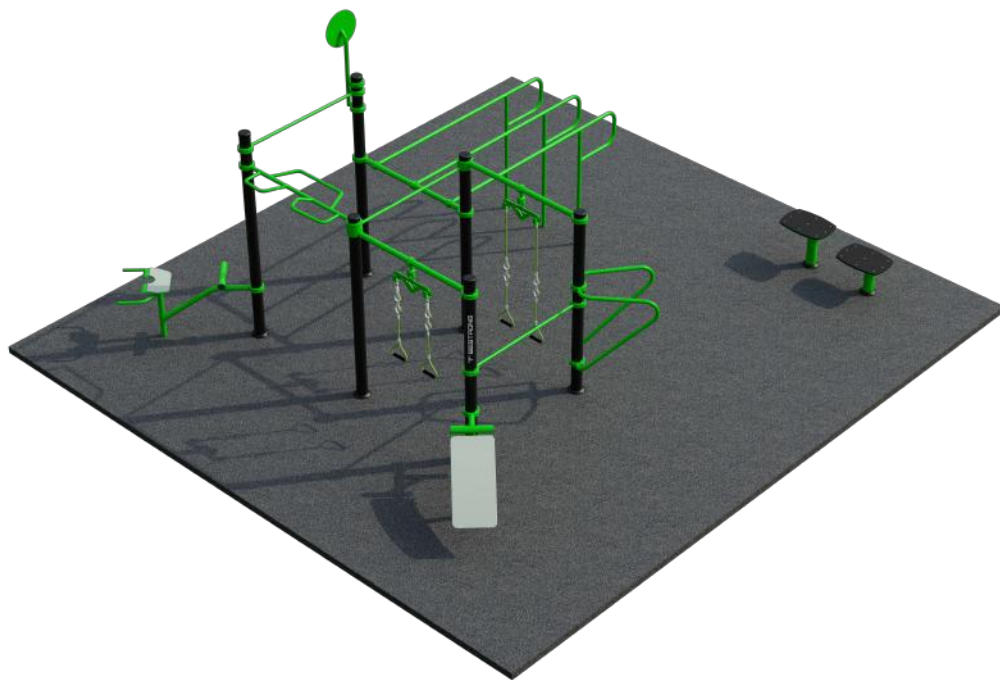

## FitCampus 1

Introducing FitCampus 1, the ultimate fitness destination exclusively designed for schools. This outdoor fitness park is specifically crafted to promote physical activity and well-being among students. With a variety of age-appropriate exercise equipment, FitCampus 1 provides a dynamic and engaging space where students can embrace an active lifestyle and foster a lifelong commitment to fitness.

## Attributes

Product code	1-3-233
Certificate	EN 16630, ASTM F3101
Age group	14 + years
Designed for	Schools
Capacity	24 people
Fall height	4'11.06 ft

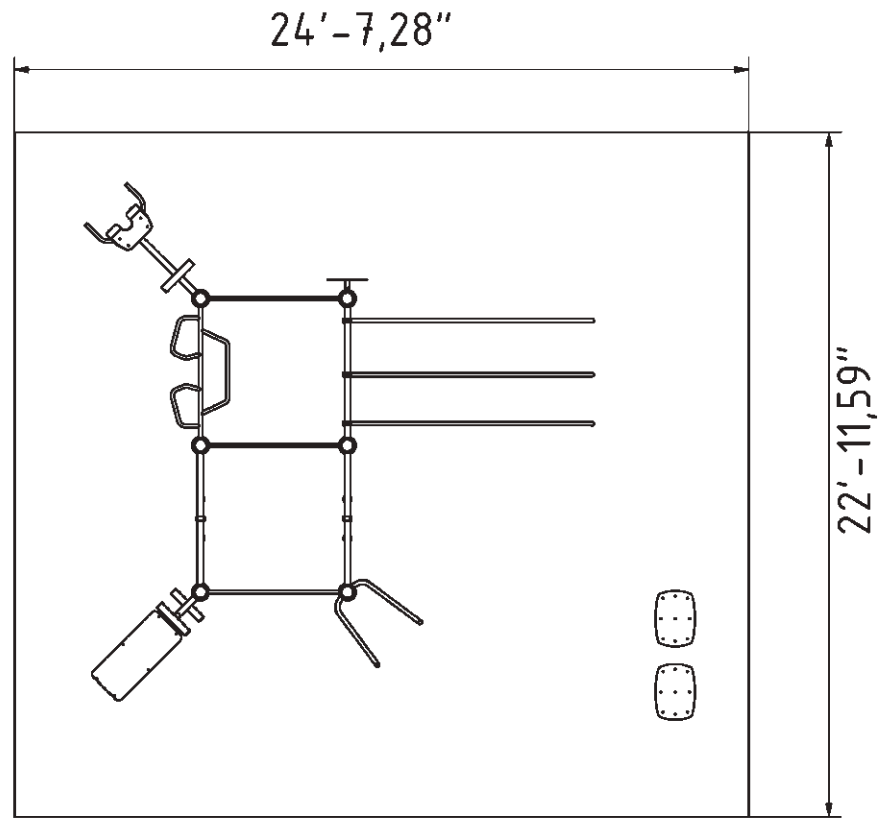

## Technical specification

Anchoring option  
 Net weight  
 Material  
 Anti-corrosion possibility  
 Total Area  
 Color options  
 For more color options, discuss with your sales representative.

In-ground or surface  
 1047 lbs  
 S235  
 Galvanized or EPD  
 565.10 ft<sup>2</sup>



## Warranty

Structure  
 Steel  
 Paint  
 Plastic  
 Rubber  
 Moving parts  
 Detailed information in the warranty document

25 years  
 15 years  
 2 years  
 5-10 years  
 1-3 years  
 2 years