

iHome®

AUTOVAC

HALO

Owner's Guide

Model iHRV7



# CONTENTS

Safety Instructions.....	1
Product Overview.....	2-7
Setting Up.....	8-9
How to Use.....	10-13
Maintenance.....	14-18
Troubleshooting.....	19-20
FCC Info.....	21

## **Questions? Contact Customer Service**

Web: [iHomeclean.com](http://iHomeclean.com)

Phone: 877-370-4580

## **Check out our helpful setup videos**

For support content and the latest digital version of this manual scan the QR code below or visit **[ihomeclean.com](http://ihomeclean.com)**



Before using this product, please read the following safety instructions and follow all safety precautions. Any operation inconsistent with this instruction manual may cause damage to this product.

## Warnings:

- Do not use products in environments with open flames or fragile objects.
- Do not allow human hair, clothes, fingers and other parts to approach the opening and operate parts of the product.
- Do not allow the Halo to pick up objects such as stones and waste paper that may clog product.
- Do not allow the Halo to pick up flammable substances such as oil, printer toner and photocopier toner.
- Do not allow the Halo to pick up any burning articles, such as cigarettes, matches, ashes and other articles that may cause fire.
- Do not place objects near the suction port. Do not use the product when the suction port is blocked. Clean up the garbage dust, wool, hair, etc to ensure smooth air circulation at the suction port.
- Use the power cord carefully to avoid damage. Do not use the power cord to drag or pull the product and the charging base. Do not use the power cord as a handle.
- Only authorized technicians can disassemble this product. Users are not recommended to disassemble this product by themselves. Doing so will void warranty.
- Only use the included power adapter. Third part adapters may damage the Halo .
- Do not touch wires, sockets or power adapters when your hands are wet.
- Do not place this product near cigarette butts, lighters and other materials with smoldering fire
- Please clean Dustbin and brushes regularly.
- Do not place any object, pets or people on top of the Halo.
- This product is an indoor household product. Do not use outdoors.
- Do not use this product in wet environment i.e, bathroom
- Before using this product, please clear the floor of all objects other than furniture as some small objects may obstruct, get caught in, or damage the Halo.
- Please use and store Halo in room temperature environments only.

No.	Description	Quantity
1	iHome Autovac Halo	1
2	iHome Auto Empty Base	1
3	Power Cable	1
4	2-in-1 Dustbin/Mop Tank	1
5	Powermop attachment	1
6	Remote Control	1
7	Dust Bag	2
8	User Manual	1
9	Mop Pad	2
10	HEPA Filter	2
11	Side Brush	2
12	Brush Cleaning Tool	1

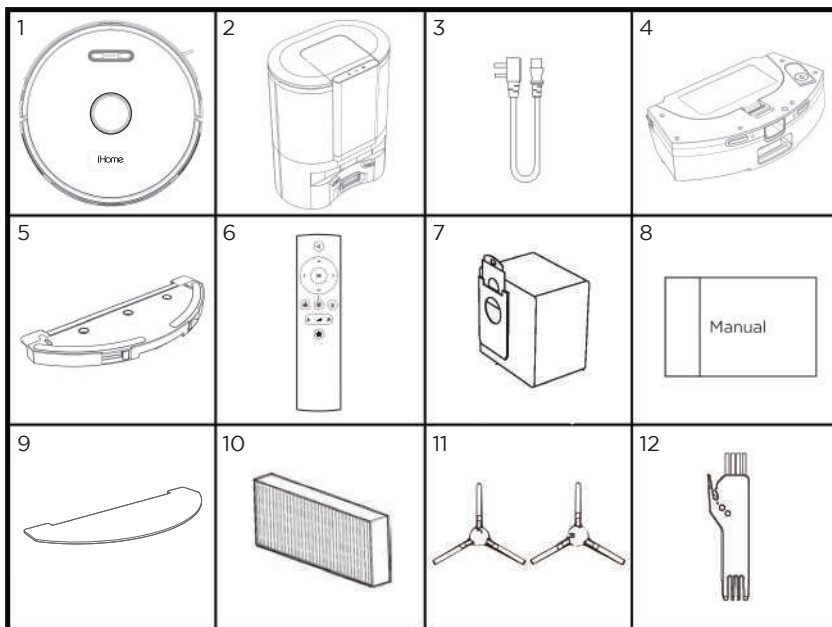

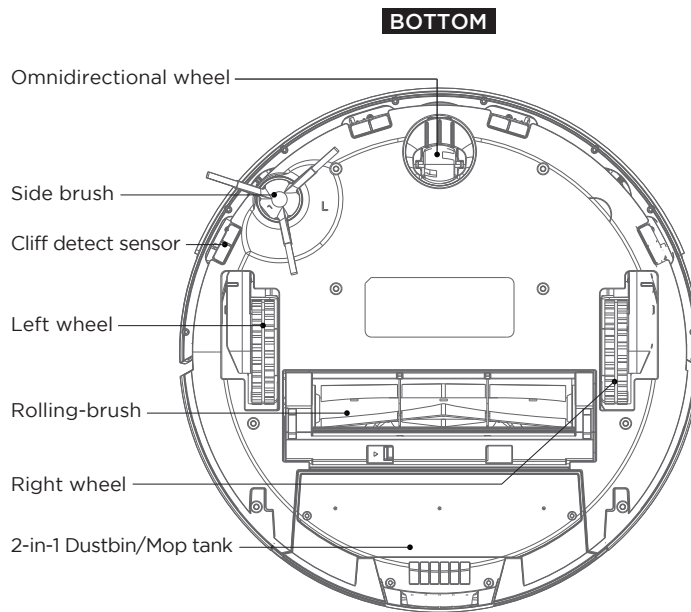
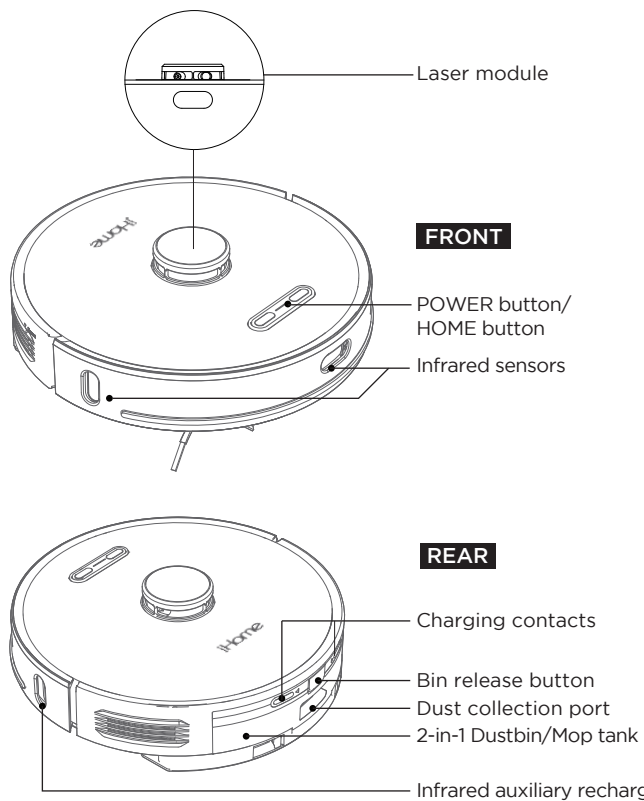

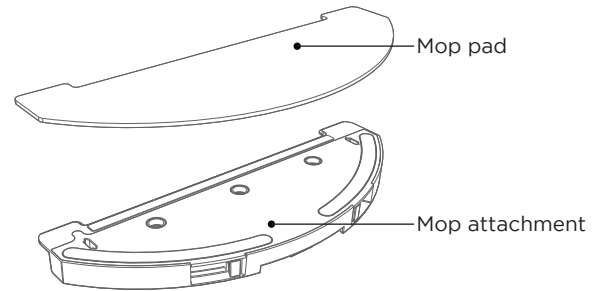
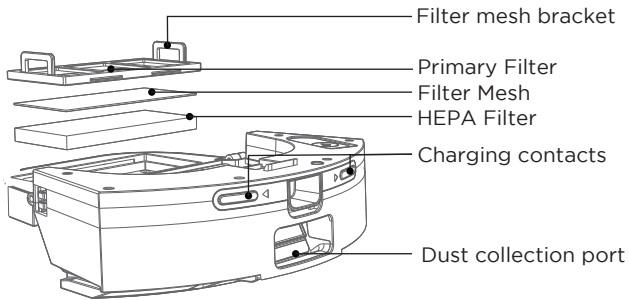
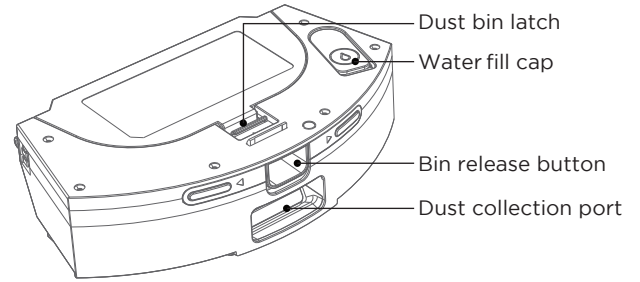
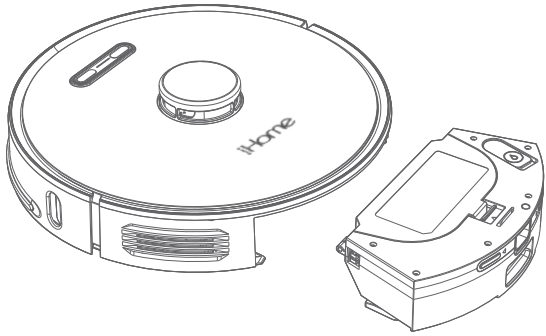

**TOP/FRONT**

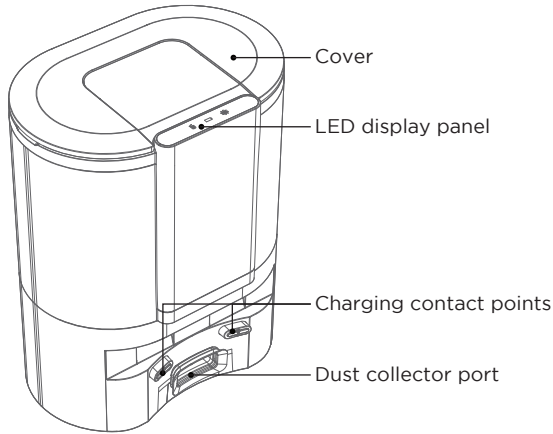

**BOTTOM/REAR**

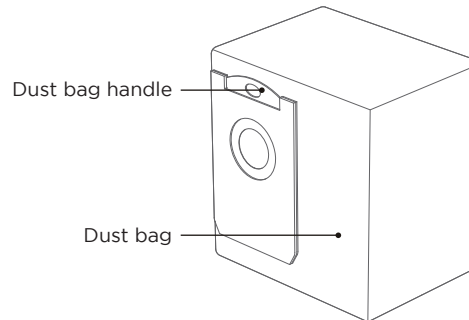
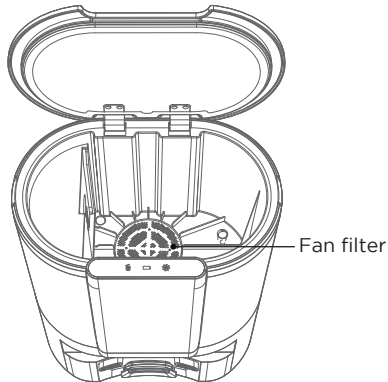
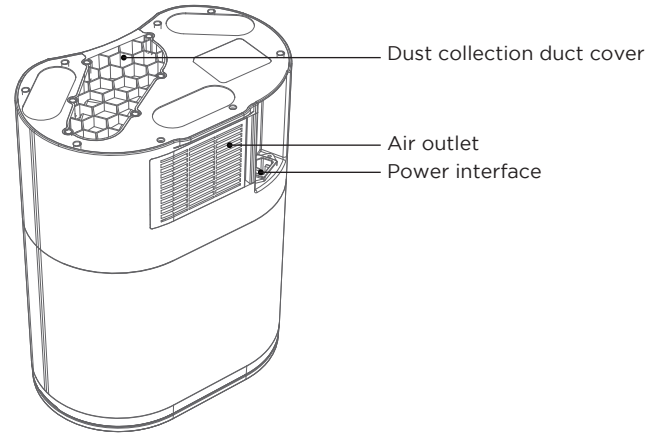

**NOTE:**

- 1:** One dustbag already pre-installed in Auto Empty Base
- 2:** Dustbag may appear “deflated”. This is normal.
- 3:** Dustbag handle must be fully lowered as shown in order for debris to enter properly.

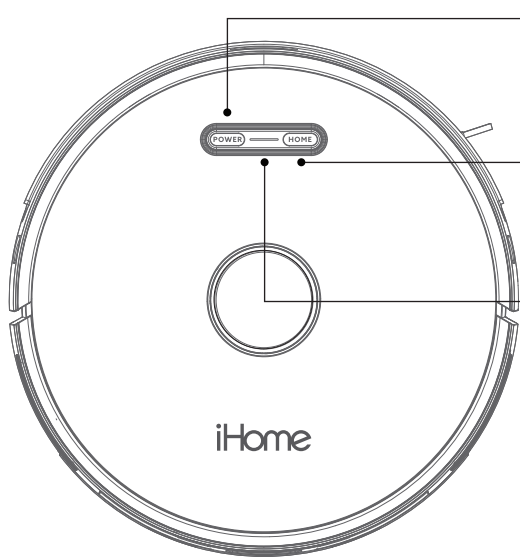

## POWER Button

- Hold to turn on/off
- Press to start/pause cleaning

## HOME Button

- Press to return to Auto Empty Base for recharging

## LED Indicator/Network Configuration

- Press & hold POWER & HOME at the same time for 5 seconds to enter network configuration
- Flashing blue light: Powering on/configuring network/upgrading firmware
- Solid blue light: Powered on/normal working state
- Flashing yellow light: Low battery/recharging
- Flashing green light: Charging
- Solid green light: Fully charged
- Flashing red light: Error state
- Light off: Off/sleeping

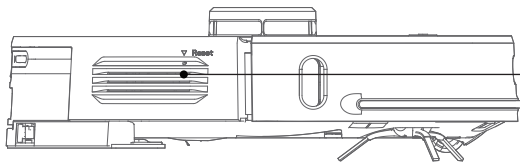

## Reset/Forced shutdown button



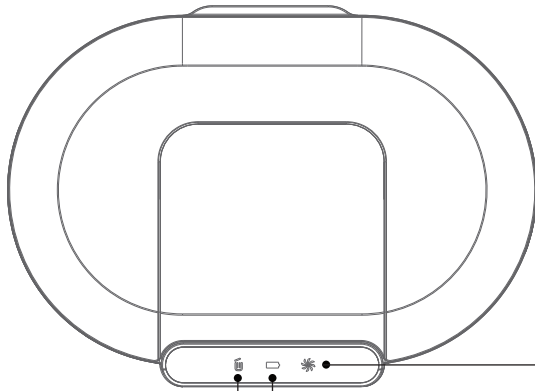

## Status Indicator

- Solid green light: Collecting dust
- Flashing red light: Fan overheating/fan error/cover not closed



## Power Indicator

- Flashing green light: Charging
- Solid green light: Fully charged/standby



## Dust Bag Indicator

- Solid green light: Dust bag is full/dust duct is blocked
- Flashing red light: Dust bag is not installed/dust bag is not installed correctly

## About your Auto Empty Base

The Auto Empty Base is designed to automatically empty and charge the iHome Autovac Halo. **Plug the power cable into the back panel of the Base and plug the other end in a functioning wall outlet. Place on a flat, hard surface at least 2.5 inches away from the wall.** Ensure that there is a clear space in front and both sides so that your Autovac Halo can return to Base to re-charge and empty.

## How to place your Auto Empty Base

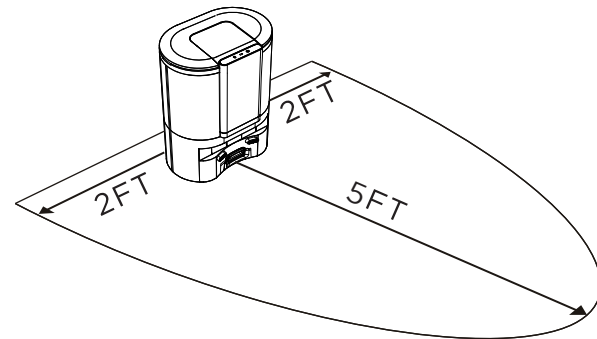
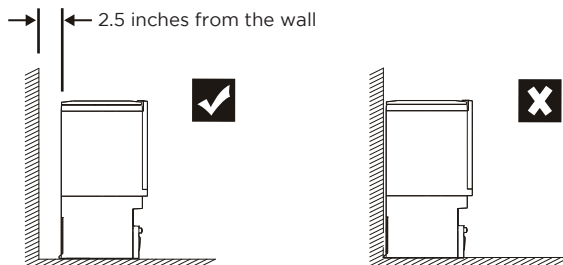

**NOTE:** The Auto Empty Base must always remain connected to power. Avoid using a power source that may inadvertently be switched off (e.g. power strip, outlet controlled by a light switch, GFCI)

## Step 1

Position the Halo on the floor near your Auto Empty Base. Press and hold the POWER button until the indicator turns blue. You will hear a welcome message.

**NOTE:** Voice prompt volume can be adjusted later in the iHome Clean App or muted using the remote control.

## Step 2

Press the HOME button to pair Halo to your Auto Empty Base. Halo will navigate and dock to the base. Allow Halo to fully charge before first use.

**NOTE:** Dust collection may activate during initial docking. Do not be alarmed. Dust collection frequency can be adjusted later in the iHome Clean App.



## Understanding your iHome Autovac Halo

The iHome Autovac Halo is designed to automatically and intelligently clean your home. Halo uses advanced laser scanning technology and multiple sensors to form a navigational map so that Halo can avoid obstructions and cliffs. Halo will continue to clean until it has determined that the addressable floor area has been covered. The navigational map is available to view in the iHome Clean app and is updated during each clean cycle to ensure that Halo takes any changes (moved furniture or other obstructions) into account.

Once cleaning is finished or the battery is low, the Halo will automatically return to the Auto Empty Base to charge and automatically empty the contents of the dustbin.

**NOTE:** Connecting Halo to Wi-Fi is not required but highly recommended. Using the iHome Clean app, you can follow the steps below to connect your Halo. The app will let you manage Halo from anywhere, set cleaning schedules, view intelligent room maps, set virtual boundaries, view cleaning history and more!

## 1: Download the iHome Clean App

Search “iHome Clean” in the App Store or use the QR code below:



## 2: Get started with this helpful video

Use the QR code below or go to [www.ihomeautovac.com/Halovideos](http://www.ihomeautovac.com/Halovideos)



**1:** Make sure your mobile device is connected to Wi-Fi

- Make sure that the Wi-Fi network is not 5G (the app only supports 2.4G network)
- The name & password of the Wi-Fi network cannot contain any special characters

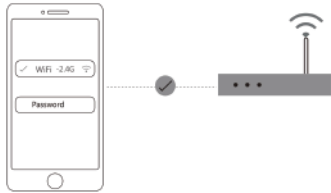

**2:** Open the iHome Clean App, select “Add device” and select Halo



**3:** Press & hold POWER & HOME simultaneously for 5 seconds to enter network config mode



NOTE: Ensure that you have a strong Wi-Fi signal in the location of your setup/charging base

**4:** Select your 2.4G Wi-Fi network and enter the password

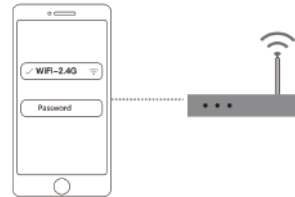

**5:** Go to Wi-Fi settings on your device and select “Autovac Halo”



**6:** Re-open the iHome Clean App & wait for the connection to complete

Before using this product, please clear the floor of all objects other than furniture as some small objects may obstruct, get caught in, or damage the iHome Autovac Halo.

## First Cleaning and Home Mapping

After the first Auto-clean cycle Halo will create a virtual map of your home, viewable in the iHome Clean app. Using that map you can define Areas and set Virtual Boundaries. Those Areas and Boundaries can then be used in any of your cleaning cycles and schedules (eg avoid the “Baby Room” during a daytime clean, mop ONLY the “Kitchen”).

Use the included remote control, or the iHome Clean APP to control your preferred cleaning method. Once you have chosen your preferred cleaning method, the Halo will start cleaning and will continue until it has covered the entire cleaning area, or until the battery is low and needs to be re-charged. Once cleaning is finished, the Halo will automatically return back to the Auto Empty Base to empty the dustbin. If a cleaning session was interrupted due to low battery, Halo will automatically resume cleaning once the power has been sufficiently restored..

## Cleaning Modes

**Auto Clean** - The Halo will automatically clean your floor until it has covered the entire surface. Once cleaning is finished or the battery needs to be re-charged, the Halo will automatically return back to the Auto Empty Base to empty the Halo’s dustbin and charge or resume cleaning

**Area Clean** - Create customizable areas on your floor-plan within the iHome Clean App for your Halo to specifically clean or avoid.

**Spot Clean** - The Halo will focus on a specific spot you desire to have cleaned thoroughly. First, use the manual navigation control on the remote (or in the app) to guide the Halo to the desired area. Then, choose Spot Clean mode.

**Powermop** - Attach the water tank attachment to the dustbin from the rear of the Halo. Choose Powermop in the iHome Clean App or the included remote and the Halo will automatically mop the surface and return to the Auto Empty Base once complete.

**Manual Control** - Using the iHome Clean App or the included remote, you can manually control where the Halo goes.

**NOTE:**

- 1: It is recommended to point the remote to the front of the Halo for best results.
- 2: The remote control range is 10-20 feet.

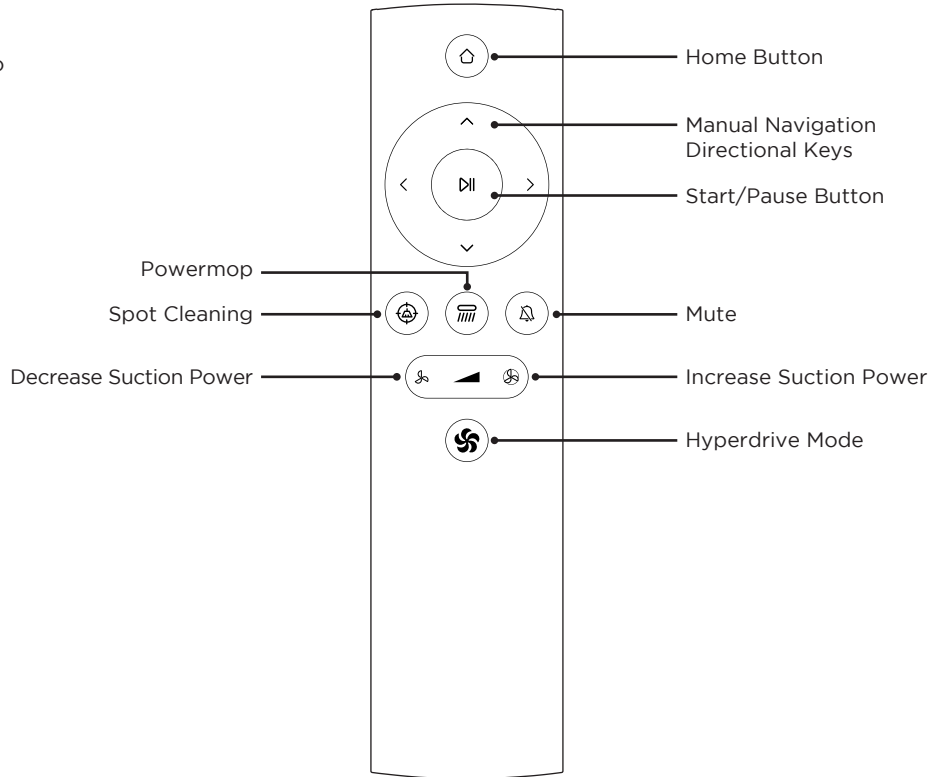
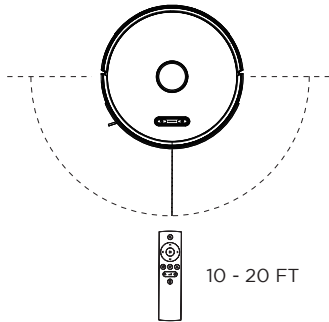

Your Autovac Halo comes equipped with a 2-in-1 Dustbin and water tank. All Halo cleaning modes activate dry vacuuming by default. The wet mopping feature adds an additional cleaning element whenever necessary. Follow these steps to use the Powermop feature.

**1:** Place the mop pad onto the mop attachment and secure it to the Velcro strips. Slip corners of the mop pad over the plastic tabs at the rear of the mop attachment.

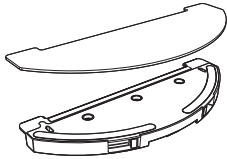

**2:** Slide mop attachment onto dustbin as shown in the figure below until you hear a click confirming that it is locked in place.

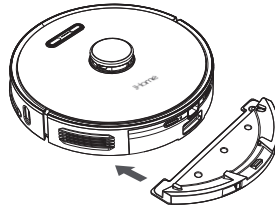

**3:** Remove the dustbin from the iHome Halo with the mop attachment still installed.

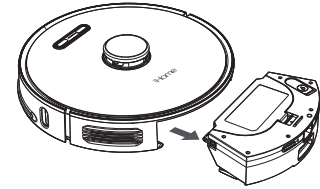

**4:** Open the water fill cap on the dustbin and fill with water, then close cap.

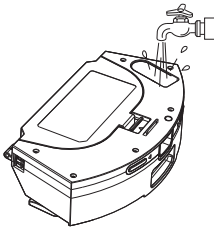

**5:** Install the dustbin with the mop attachment still installed into the Halo according to the figure below.

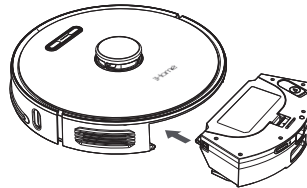

**6:** Activate Powermop mode in the app or using the remote control.

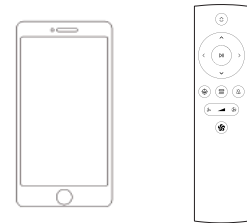

## NOTES

- To avoid carpet while mopping, set up virtual boundaries within the iHome Clean App
- To avoid leakage, install the mop attachment onto the dustbin before filling with water
- Make sure to empty any left over water from the tank after mopping



Your Halo is designed to be used regularly. As with most floor care devices, regular use may cause build-up around brushes, in debris compartments and near filters. We recommend performing regular maintenance, as outlined in the following pages, to keep your iHome Autovac Halo running at optimal performance.

- 1:** Pinch the left and right tabs on the main brush cover. Lift and remove the cover.
- 2:** Remove the main brush and clean with included cleaning tool as seen in the figure below.
- 3:** Replace the main brush and snap the cover back into place.

**NOTE:** It is recommended to replace the main brush every 6-12 months depending on use.

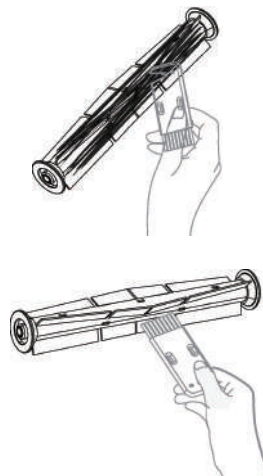
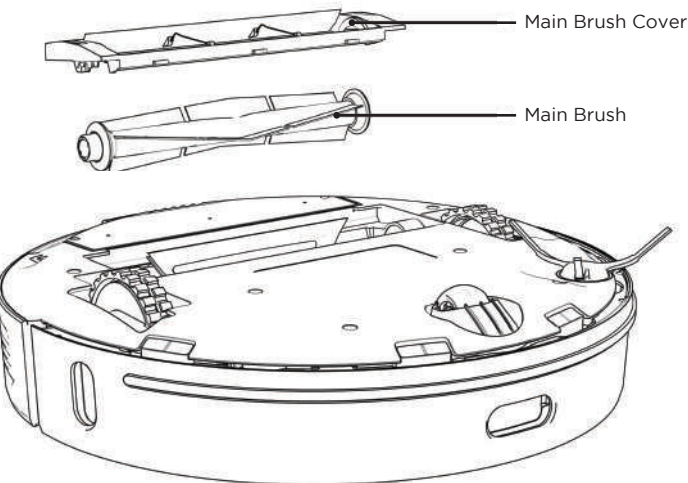

## MAINTENANCE SCHEDULE

PART	CARE FREQUENCY	REPLACEMENT FREQUENCY
Main Brush	Once a month	Once a year
Side Brushes	Once a month	Once a year
HEPA Filter	Every 2 weeks	Every 3 months
Main Filter	Every 2 weeks	Twice a year

**1:** Press the dust bin release button and remove the dust bin.

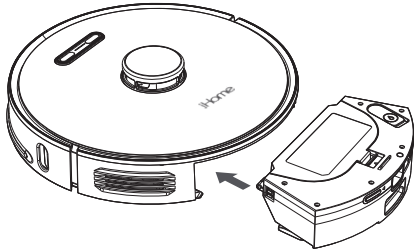

**2:** Open the dust bin and empty contents.

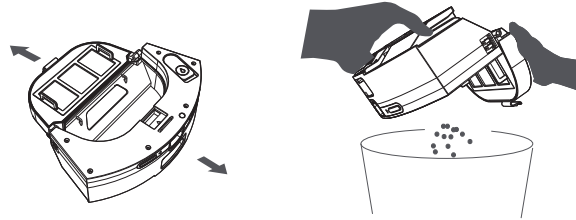

**3:** Remove the primary filter and HEPA filter, wipe down the surface with a dry cloth or use the cleaning tool. Rinse the primary filter with water and let dry.

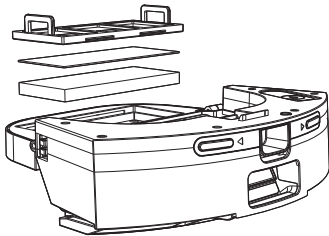

**4:** Remove the mop pad to wash (machine washable)

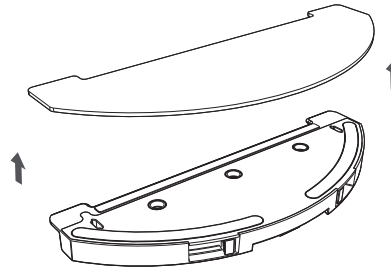

**1:** Use a Philips screwdriver to unscrew the side brush screw and remove the side brush.

**2:** Remove dirt and debris and reinstall using Philips screwdriver.

**NOTE:** It is recommended to replace the side brush every 3-6 months depending on use.

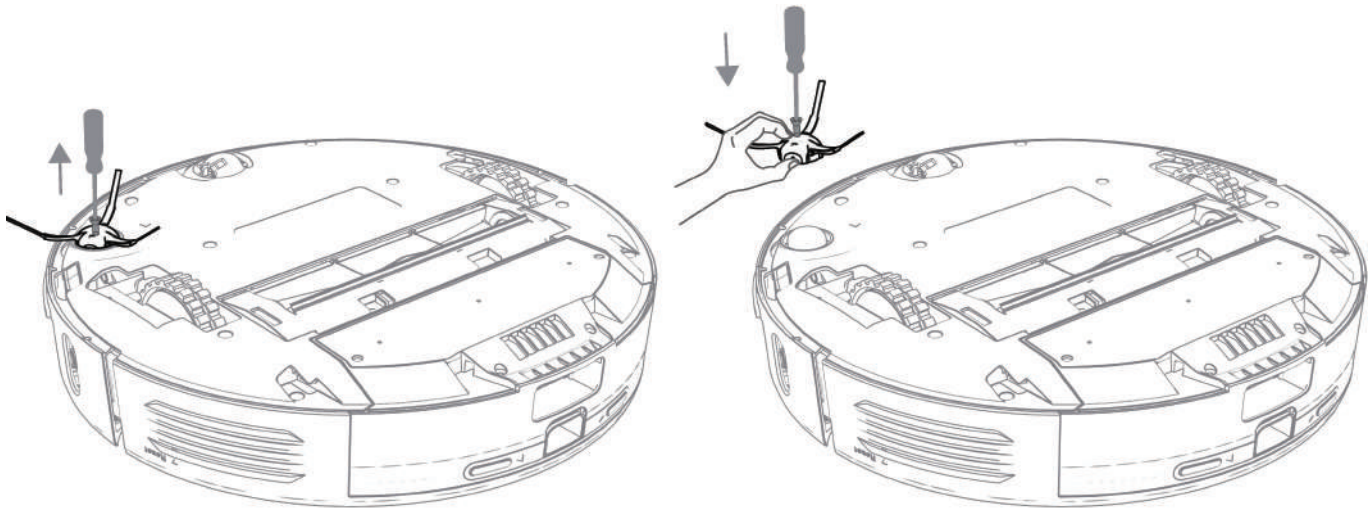



## Auto Empty Base Dust Bag

The Auto Empty Base will indicate when the dust bag is full on the smart LED display panel (Dust bag indicator will be green). Discard of dust bag once full and replace dust bag with a new one. **NOTE:** Extend the dust bag handle to seal the debris hole.



## Filter Maintenance



If the Auto Empty Base indicator light  flashes or the trash icon  is solid green and the dust bag is not full, it is time to clean the filter.

**1:** Unplug the Auto Empty Base and turn it over. Use a Philips screwdriver to remove the screws as shown in the figure to the right. Open the dust duct cover to clean out any dirt and debris.

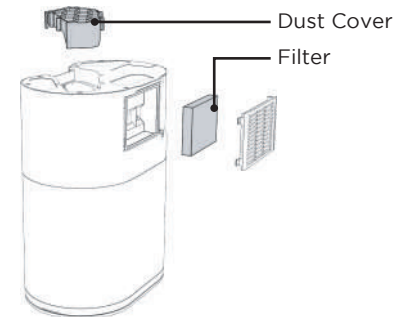
**2:** Open the exhaust at the rear of the Auto Empty Base, clean the filter, and reinstall.



PROBLEM	SOLUTION
Unable to power on	Please charge before use. This is commonly caused due to low battery.
Unable to start cleaning	Please charge before use. This is commonly caused due to low battery.
Unable to return to Auto Empty Base	<ul style="list-style-type: none"> <li>• There are too many obstacles near the Auto Empty Base. Please make sure there is a clear area 2 FT of space on either side and 5 FT in front of the Auto Empty Base.</li> <li>• The Halo is out of range of the Auto Empty Base. Move the Halo closer to the Auto Empty Base to re-establish connection.</li> </ul>
Abnormal behavior	Power down and restart.
Abnormal noise during cleaning	Main brush, side brush or left/right wheel may be obstruction, Check underneath the Halo to make sure it is clear from any obstruction. If there is an obstruction clear it and restart the Halo.
Decrease in cleaning ability or dust falling out from dustbin.	<ul style="list-style-type: none"> <li>• The dustbin is full, please empty the dustbin.</li> <li>• Check and clean the HEPA filter.</li> <li>• Check that the brush is clear from obstruction.</li> </ul>
Unable to connect to Wi-Fi	Wi-Fi signal is not good , please check that there is a strong Wi-Fi connection while paring. Make sure the network is 2.4G and not 5G or dual band.
Halo is not returning to the Auto Empty Base after spot cleaning or after moving it far from the Auto Empty Base.	After spot cleaning or moving the Halo far from the Auto Empty Base the Halo will re-generate the map. If the Halo is far from the Auto Empty Base it may not be able to locate it. Please manually dock the Halo to the Auto Empty Base to recharge.
Unable to charge after docking	Make sure there is no obstruction or heavy dust on both the Halo and Auto Empty Base charging contacts.
Scheduled cleaning not working	Please confirm that the Halo is connected to your Wi-Fi network. If the Halo is not connected to the network you cannot synchronize the scheduled cleaning task.

INDICATOR	DEFINITION	SOLUTION
 <p>Flashing red</p>	<ul style="list-style-type: none"> <li>• Fan error</li> <li>• Overheating</li> <li>• The cover is not closed properly</li> </ul>	<ol style="list-style-type: none"> <li>1. Frequent dust collection leads to fan overheating protection or fan malfunction. It is recommended to try to collect dust after 30 minutes.</li> <li>2. Ensure that the cover of the Auto Empty Base is completely closed and that the Autovac Halo is properly docked and charging.</li> </ol>
 <p>Flashing red</p>	<ul style="list-style-type: none"> <li>• The dust bag is not installed</li> <li>• The dust bag not installed properly</li> </ul>	<ol style="list-style-type: none"> <li>1. Ensure that the dust bag is properly installed and fully lower the cardboard handle (see figure on page 18).</li> <li>2. Check whether the dust bag is installed. If not, please install the dust bag.</li> </ol>

**1:** This device complies with Part 15 of the FCC Rules. Operation is subject to the following two conditions: (1) This device may not cause harmful interference, and (2) This device must accept any interference received, including interference that may cause undesired operation.

**2:** Changes or modifications not expressly approved by the party responsible for compliance could void the user's authority to operate the equipment.

**NOTE:** This equipment has been tested and found to comply with the limits for a Class B digital device, pursuant to Part 15 of the FCC Rules. These limits are designed to provide reasonable protection against harmful interference in a residential installation. This equipment generates uses and can radiate radio frequency energy and, if not installed and used in accordance with the instructions, may cause harmful interference to radio communications. However, there is no guarantee that interference will not occur in a particular installation. If this equipment does cause harmful interference to radio or television reception, which can be determined by turning the equipment off and on, the user is encouraged to try to correct the interference by one or more of the following measures: Reorient or relocate the receiving antenna. Increase the separation between the equipment and receiver.

Connect the equipment into an outlet on a circuit different from that to which the receiver is connected. Consult the dealer or an experienced radio/TV technician for help.

### **FCC Radiation Exposure Statement**

This equipment complies with FCC radiation exposure limits set forth for an uncontrolled environment.

This equipment should be installed and operated with minimum distance 20cm between the radiator & your body.