

Digital fabrication

Showcase

By ARTs, ARTCs, and RhinoFabStudios®

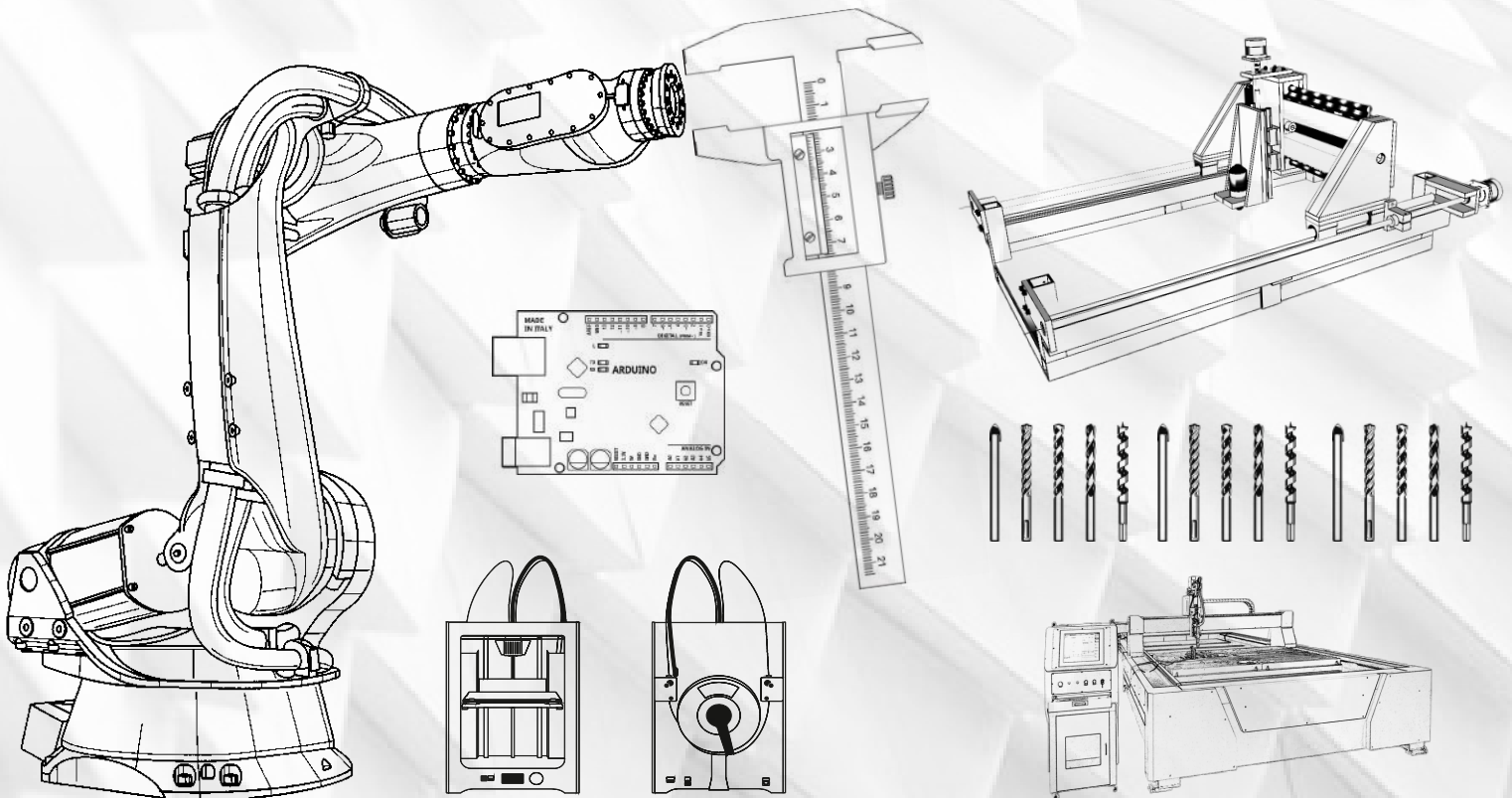



Today we thank all the certified RhinoFabStudios that participated in this construction. This year, we have created this portfolio called "RhinoFabStudio Showcase" in order to include the most outstanding projects manufactured in RhinoFabStudios around the world and thus build community and dissemination.

Hoy agradecemos a todos los RhinoFabStudios certificados que participaron de esta construcción. Este año, hemos creado este portafolio llamado "RhinoFabStudio Showcase" con el fin de incluir los proyectos más sobresalientes fabricados en los RhinoFabStudios alrededor del mundo y así construir comunidad y difusión.



-
- + *Rhino Jewelry CAD*
 - + *University of New Mexico SA+P*
 - + *Akiyo Matsuoka Inc.*

By ARTs, ARTCs, and RhinoFabStudios[®]



RhinoFabStudio®

• **Name:** Akiyo Matsuoka • **Email:** akiyo@akiyomatsuoka.com

• **Company:** Akiyo Matsuoka Inc. • **Website:** leonany.com, akiyomatsuoka.com

• **City:** New York • **Country:** U.S.A.

L E O
N A

• **Project Info:** Designed with Rhino and Grasshopper. Printed with Selective Laser Sintering 3D printer.

Available at www.leonany.com.

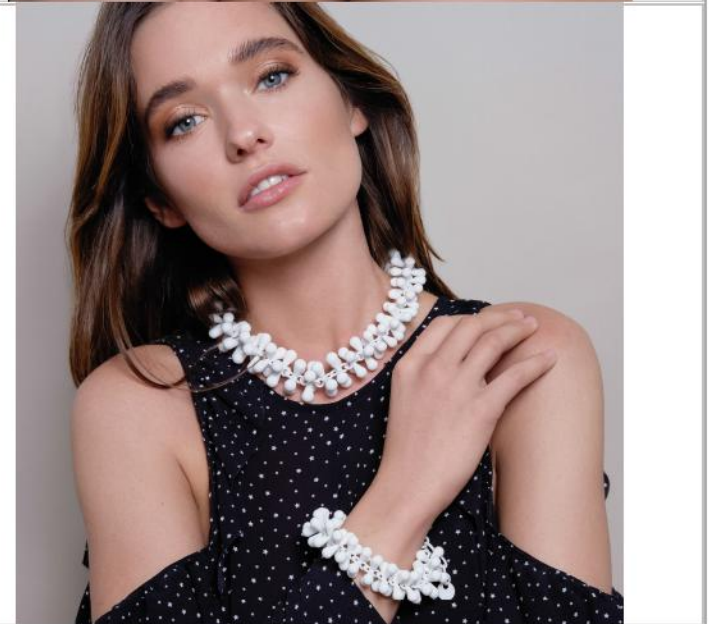
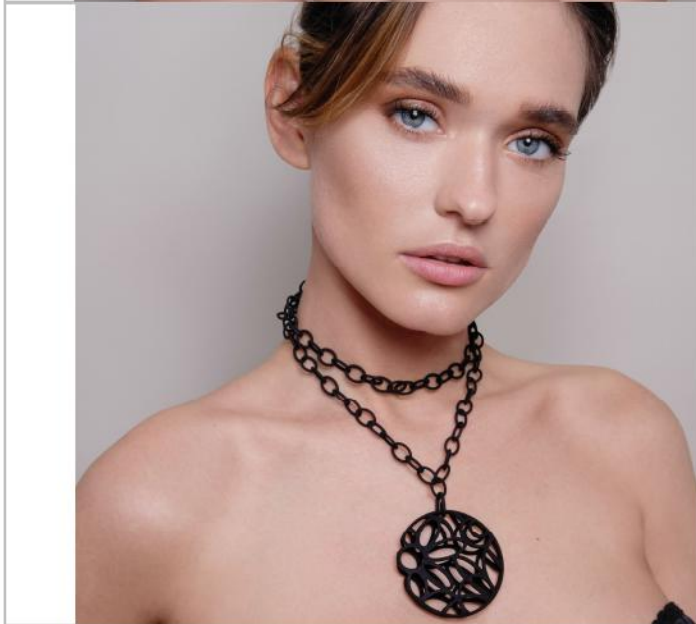
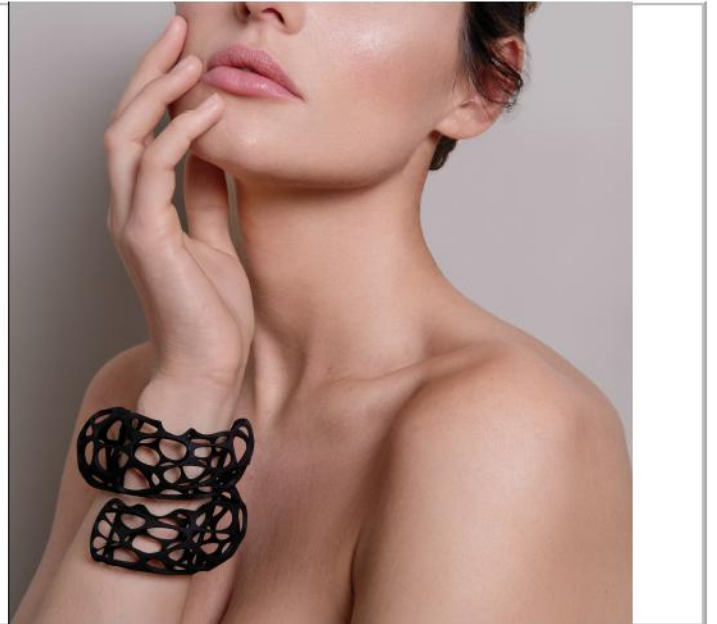
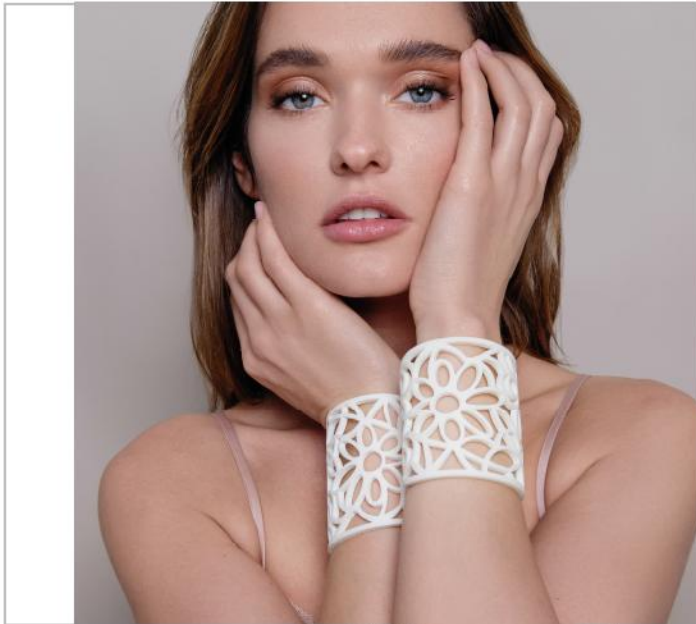



RhinoFabStudio[®]

- **Name:** Akiyo Matsuoka
- **Email:** akiyo@akiyomatsuoka.com
- **Company:** Akiyo Matsuoka Inc.
- **Website:** leonany.com, akiyomatsuoka.com
- **City:** New York
- **Country:** U.S.A.
- **Project Info:** Business card case with hinges. Designed with Grasshopper and Rhino. Printed with Selective Laser Sintering 3D printer. Available at www.leonany.com

LEONANY

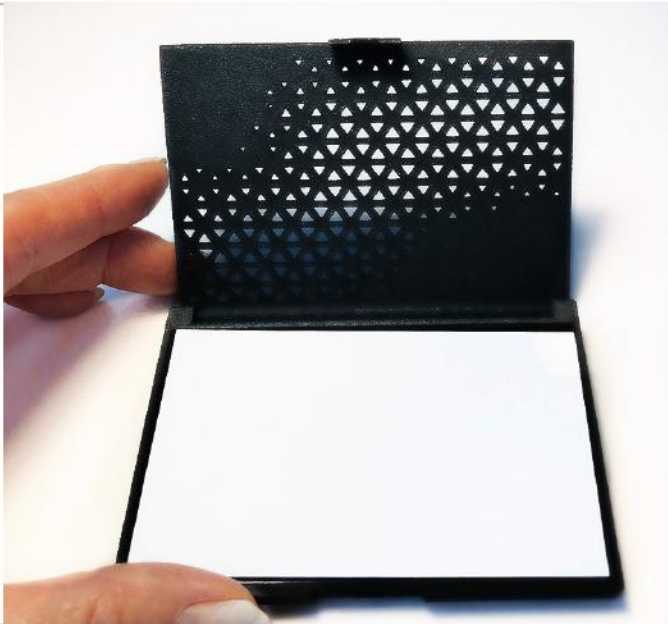



Rhino**Fab**Studio[®]

- Name: Gary Dawson
- Email: gary@garydawsondesigns.com
- Company: Rhino Jewelry CAD
- Website: https://www.rhinojewelrycad.com/#/
- City: Eugene, Oregon
- Country: USA



•Project Info: This was a custom ring design for my client. The center gem was a family heirloom and I supplied the tapered Sapphire baguettes. As you can see from the process images, I used Rhino throughout in designing this ring. It was then printed on a DLP 3-D printer and cast in white gold

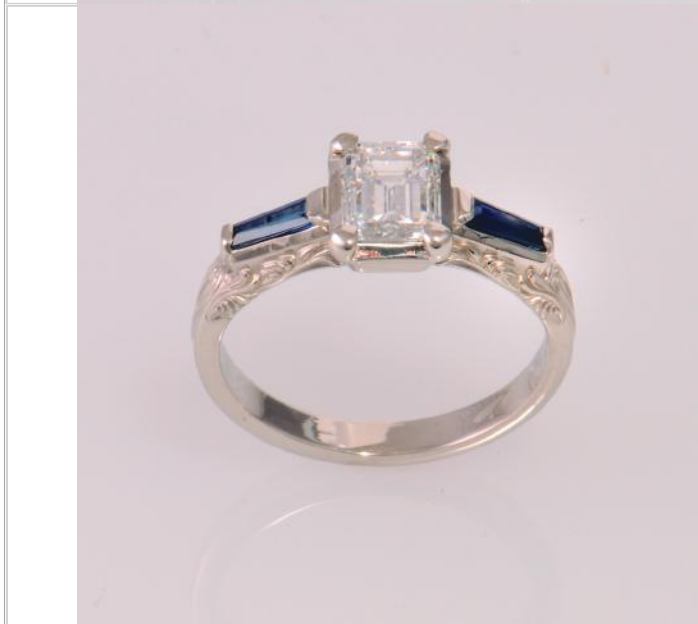
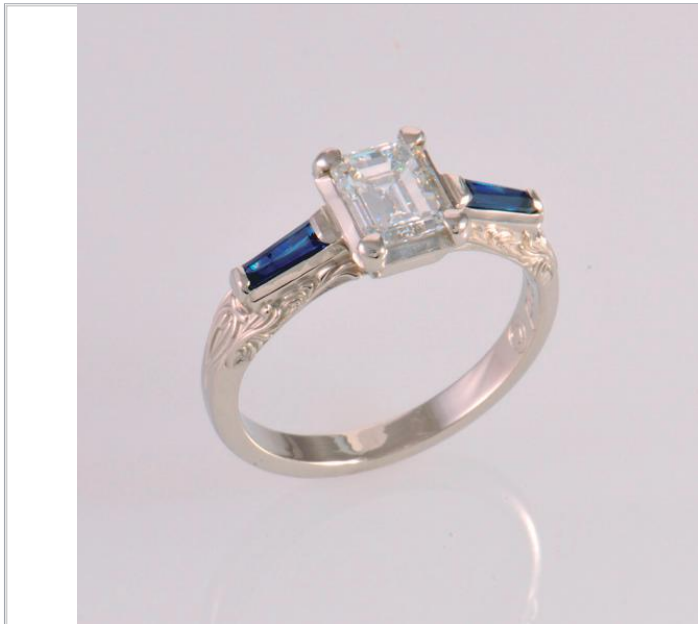



RhinoFabStudio®

- **Name:** Alec Vittitow + Stephen Mora (Instructor) • **Email:** sedmora@unm.edu
- **Company:** [University of New Mexico SA+P](http://saap.unm.edu) • **Website:** saap.unm.edu
- **City:** [Albuquerque NM](http://Albuquerque, NM) • **Country:** USA



- **Project Info:** [Used Rhino to fully model the tower and the connections between each material. Took lines from Make 2D for laser cut files and utilized Rhino Cam for CNC milling to create the model.](#)





RhinoFabStudio®

- **Name:** Stephen Mora + Tim Castillo
- **Email:** sedmora@unm.edu
- **Company:** University of New Mexico SA+P
- **Website:** saap.unm.edu
- **City:** Albuquerque, New Mexico
- **Country:** USA



- **Project Info:** The Maker Lab Express was designed and modeled primarily in Rhino and CNC cut using Rhino CAM. It is intended to introduce kids to new methodologies of creation and inspire them to engage in current and emerging professions in STEM.





RhinoFabStudio®

- **Name:** Garret Schultz, Instructor: Stephen M • **Email:** garretschultz24@gmail.com
- **Company:** University of New Mexico SA+P • **Website:** saap.unm.edu
- **City:** Albuquerque, NM • **Country:** USA



• **Project Info:** This custom contour chair, titled *Lordosis*, required a combination of digital / physical input to achieve the desired ergonomics (prototype). The final design is CNC routed plywood and was modeled in Rhino 3D and cut using RhinoCAM.

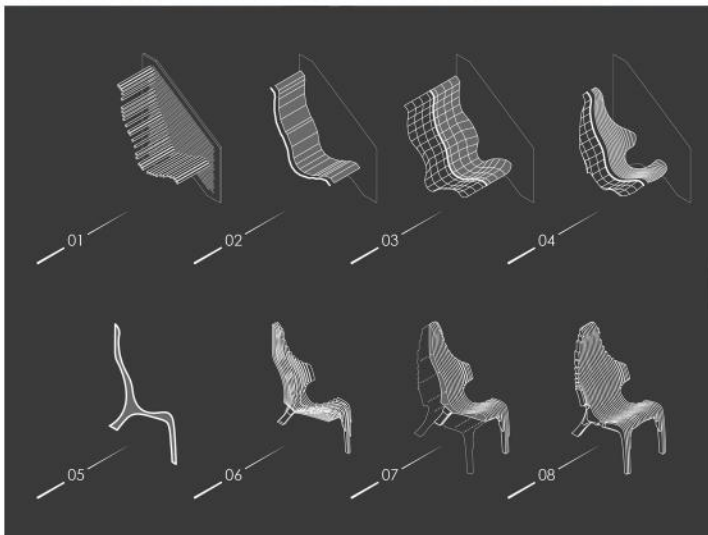



-
- + *McNeel Miami*
 - + *Universidad Pontificia Bolivariana*
 - + *LOBO Designer*
 - + *UTRNG*
 - + *Tec de Monterrey*
 - + *SI CAD-CAM*

By ARTs, ARTCs, and Rhino**Fab**Studios[®]



Rhino**Fab**Studio[®]

•**Name:** Parametric Bracket

•**Email:** andres@mcneel.com

•**Company:** McNeel Miami

•**Website:** www.McNeelMiami.com

•**City:** Miami, Florida

•**Country:** USA



•**Project Info:** Designed with Rhino 6 and Grasshopper, printed with ABS filament.





RhinoFabStudio®

•Name: Parametric Hat

•Email: andres@mcneel.com

•Company: McNeel Miami

•Website: www.McNeelMiami.com

•City: Miami, Florida

•Country: USA



•Project Info: Designed by Donatto Punyet at McNeelMiami's RhinoFabStudio. Cut with a Trotec Laser.

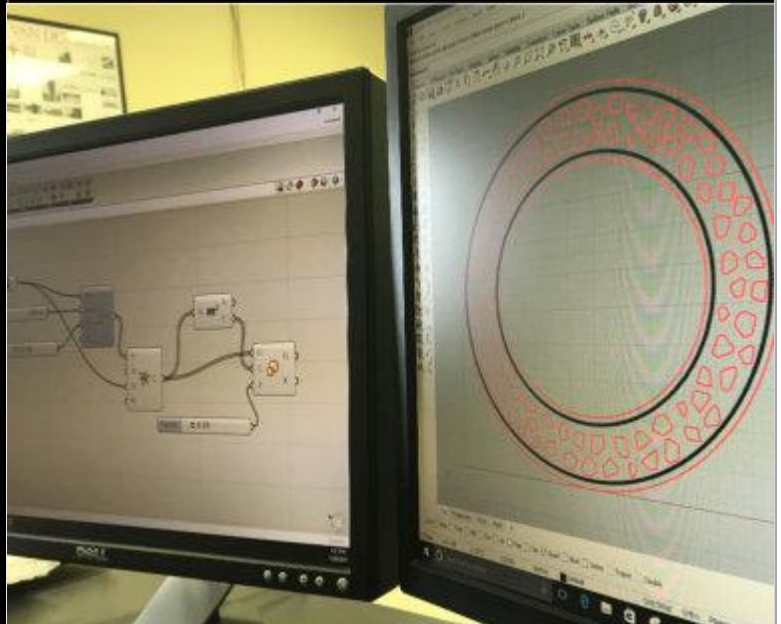
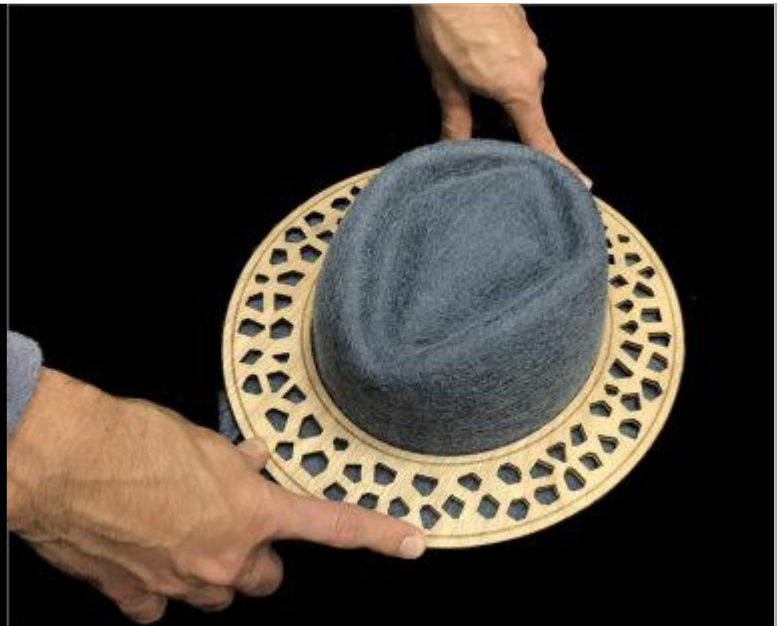



RhinoFabStudio®

•Name: Skateboard

•Email: andres@mcneel.com

•Company: McNeel Miami

•Website: www.McNeelMiami.com

•City: Miami, Florida

•Country: USA



•Project Info: Designed by Ana, Saky and Beatriz, students from TEC of Monterrey at Guadalajara, during their Minor in Design and Fabrication at McNeel Miami's RhinoFabStudio. The pattern was done with Paneling Tools for Grasshopper.





RhinoFabStudio®

•Name: Parametric Lamp

•Email: andres@mcneel.com

•Company: McNeel Miami

•Website: www.McNeelMiami.com

•City: Miami, Florida

•Country: USA



•Project Info: Designed with Rhino and Grasshopper and cut with a Trotec Laser

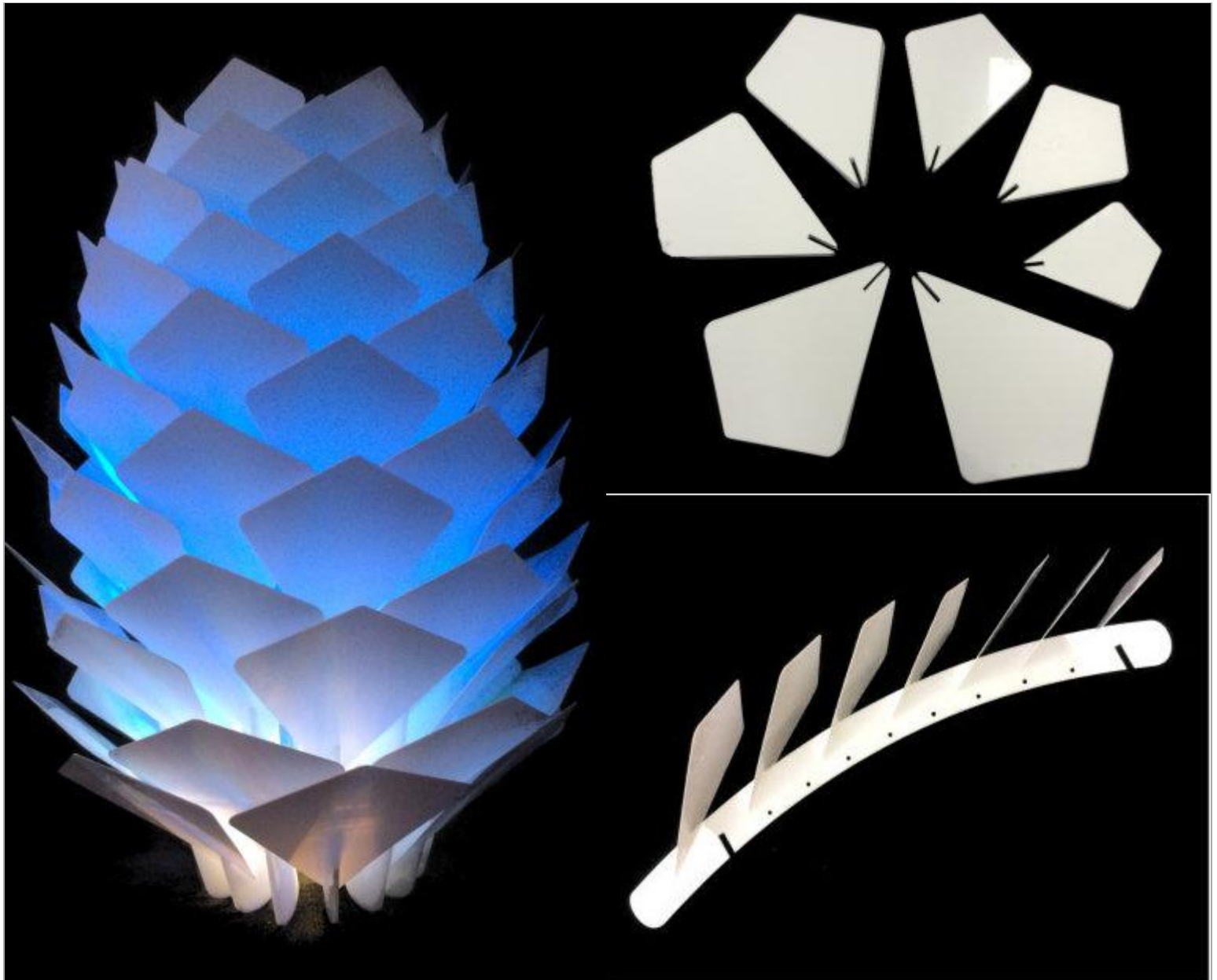



RhinoFabStudio®

•Name: Injection mold for chocolates

•Email: andres@mcneel.com

•Company: McNeelMiami

•Website: www.McNeelMiami.com

•City: Miami, Florida

•Country: USA



•Project Info: Designed in Rhino and then 3D printed the injection molds to make chocolate lollipops.





Rhino**Fab**Studio[®]

•**Name:** Tea Storage Box

•**Email:** andres@mcneel.com

•**Company:** McNeel Miami

•**Website:** www.McNeelMiami.com

•**City:** Miami, Florida

•**Country:** USA



•**Project Info:** Designed with Rhino and mill with RhinoCAM and a Shopbot CNC router.





RhinoFabStudio®

• **Name:** Luis Beltran Lobo Ubrina

• **Email:** luisbeltran88@gmail.com

• **Company:** Freelancer

• **Website:** be.net/LOBO_Designer

• **City:** Santiago

• **Country:** Chile



• **Project Info:** The objective was to design and manufacture a trailer. This bar should work for the tasting of beer, in indoor and outdoor spaces. Using music as a resource, people around were attracted by the trailer. Designed entirely and fabricated using Rhinoceros, including files for CNC and more.





RhinoFabStudio®

• **Name:** Luis Beltran Lobo Ubrina

• **Email:** luisbeltran88@gmail.com

• **Company:** Freelancer

• **Website:** be.net/LOBO_Designer

• **City:** Santiago

• **Country:** Chile



• **Project Info:** Bobi is a stand (for the sale of food) made of fiber glass and it's orange shells allows a fast and accurate modulation. Rhino was a powerful tool during the design process, which helped to achieve an amazing shape and unite all the requirements requested for the client in one shape.





RhinoFabStudio®

- **Name:** Luis Beltran Lobo Ubrina
- **Email:** luisbeltran88@gmail.com
- **Company:** Freelancer
- **Website:** be.net/LOBO_Designer
- **City:** Santiago
- **Country:** Chile



- **Project Info:** Rhino was the main tool to create the Wisdom Knife's hard case, made and created in black hard plastic. Also, Rhino was useful for visualize the packaging with the hard case and the knife in real time for approval. In this case, a photo of the real product ready for the release on the market.





RhinoFabStudio[®]

- **Name:** Design and manufacturing of a dry electrode
- **Email:** ara_0588@hotmail.com, ingarturo@gm
- **Company:** IPN-UTRNG
- **Website:** www.utrng.edu.mx
- **City:** Iguala, Gro.
- **Country:** Mexico



• **Project Info:** EMG is usually made with wet electrodes, the main goal was to build a dry electrode with microneedles, our FABSTUDIO designed and fabricated it with the sisma laser the complete research was published in the book: Improved Performance of Materials: Design and Experiment

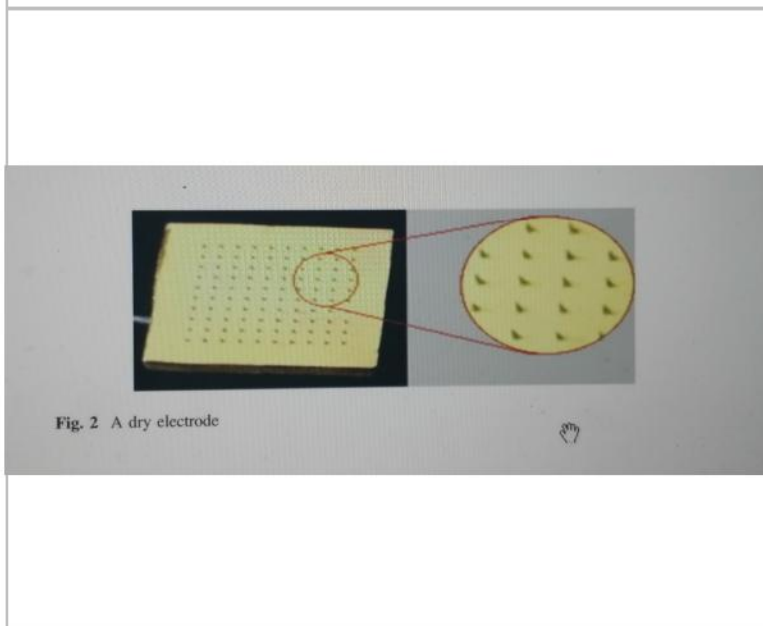
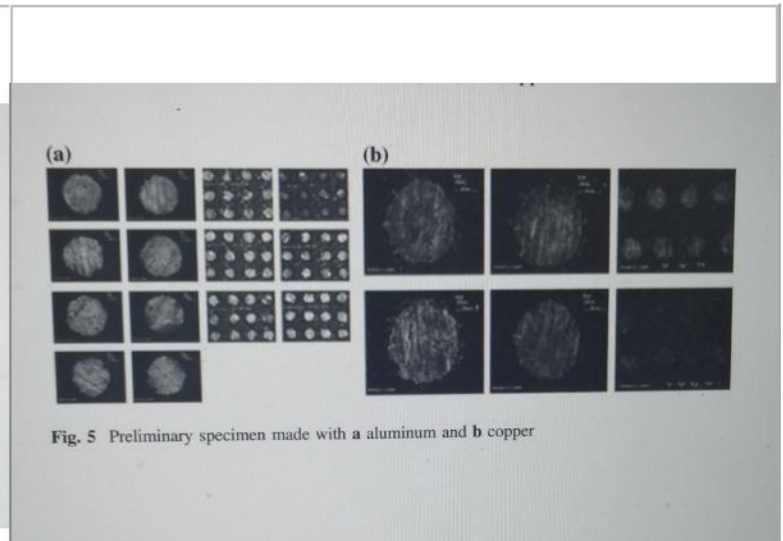
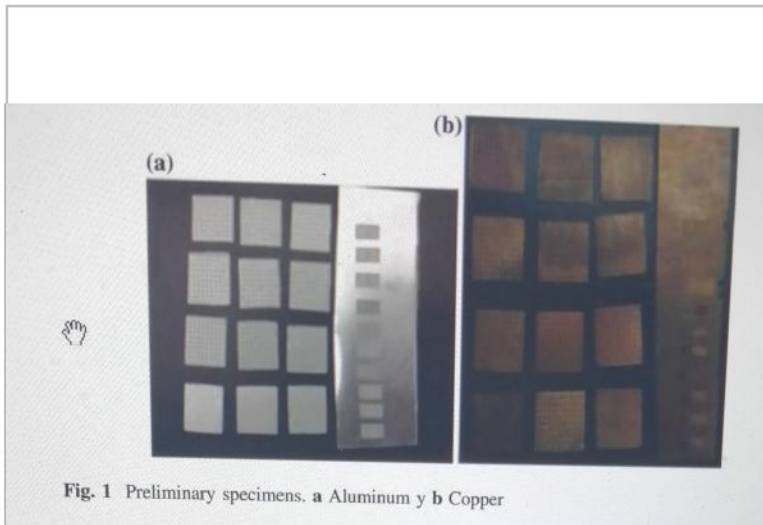



RhinoFabStudio®

• **Name:** Arturo Flores

• **Email:** ingarturo@gmail.com

• **Company:** UTRNG

• **Website:** www.utrng.edu.mx

• **City:** Iguala, Gro.

• **Country:** Mexico



• **Project Info:** In the Regional Sport games, we fabricated the thorch and the cauldron, all of the designs were made in Rhino and two machines were used, a VMC Hass VF-1, running the code generated from RhinoCAM and a Laser SISMA Big Smark.

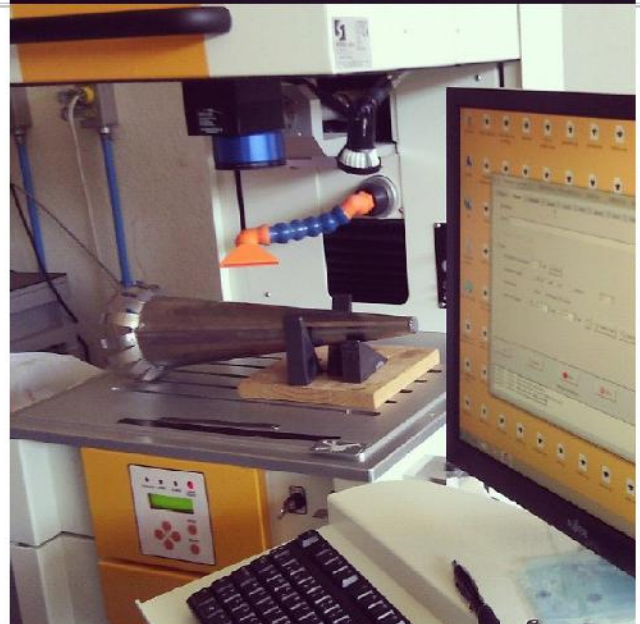
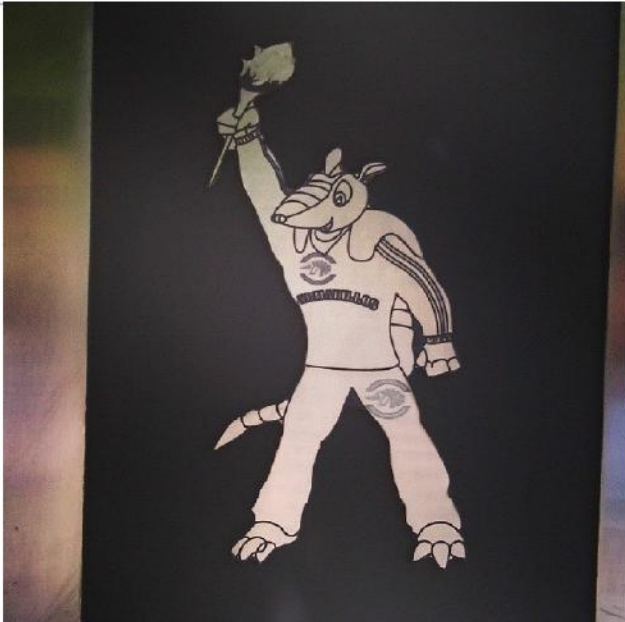



RhinoFabStudio®

- **Name:** Commemorative plates
- **Email:** ingarturo@gmail.com
- **Company:** UTRNG
- **Website:** www.utrng.edu.mx
- **City:** Iguala, Gro.
- **Country:** Mexico



• **Project Info:** Identification plates, located under the statues of Vicente Guerrero and Juan Alvarez in the museum of the national flag in Iguala Guerrero, city known as the crib of the Mexican flag.

Designed in Rhinoceros, RhinoCAM and fabricated in Hass VF-1.

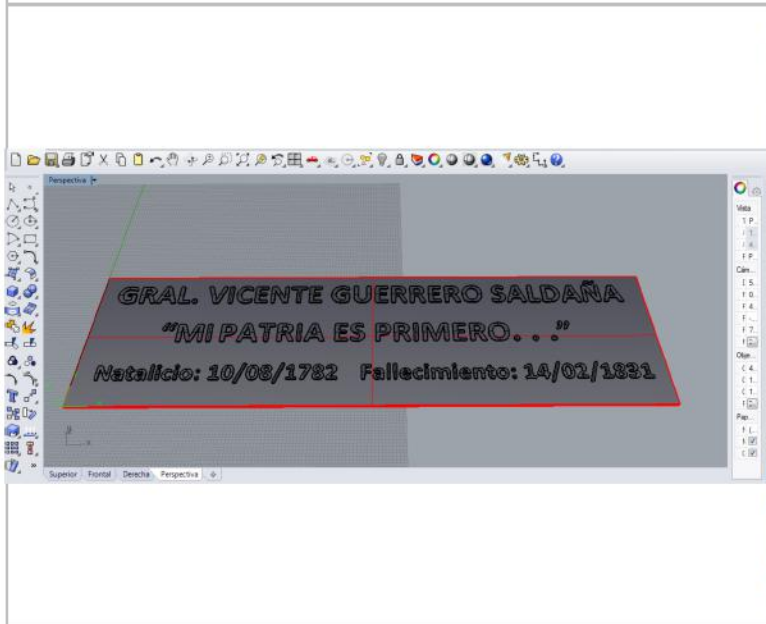
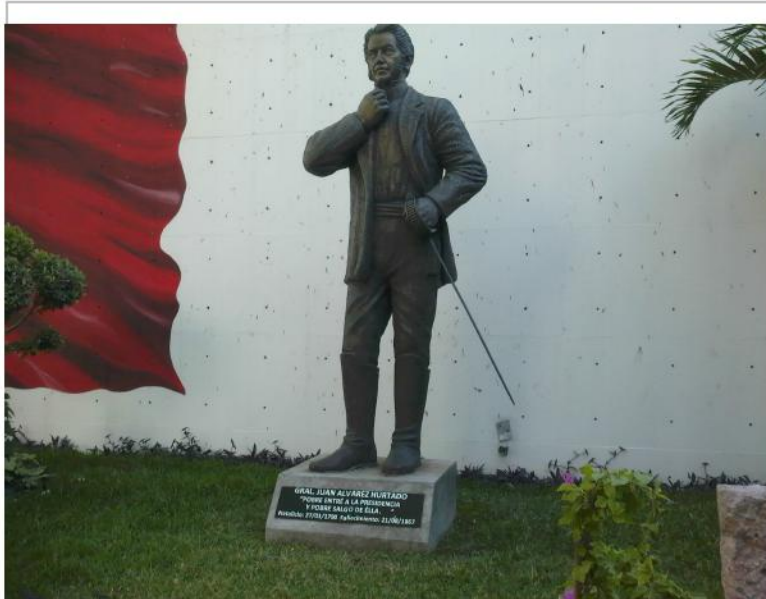



RhinoFabStudio®

- **Name:** Tutor for tomatoes plants. _____
- **Email:** ingarturo@gmail.com, itoledoh@utrng.edu.mx
- **Company:** UTRNG _____
- **Website:** www.utrng.edu.mx _____
- **City:** Iguala, Gro. _____
- **Country:** Mexico _____



- **Project Info:** In several crops are used tutors (large stick) between the plants grow, most of the times in México they use oate trees, in this project we designed and builded a mold for a modular tutor made of recycled plastic. Designed in Rhino and the CNC code was made in RhinoCAM and the mold was build in steel, using the VMC Hass VF1

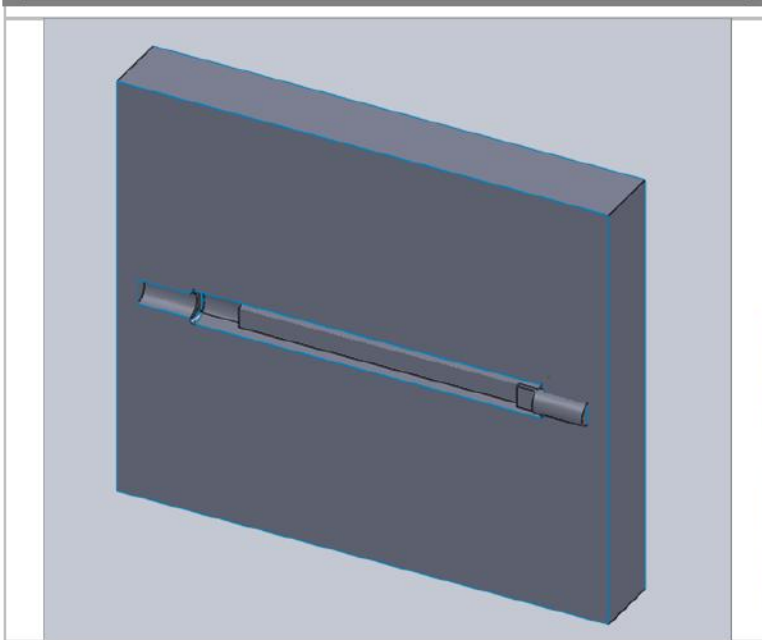
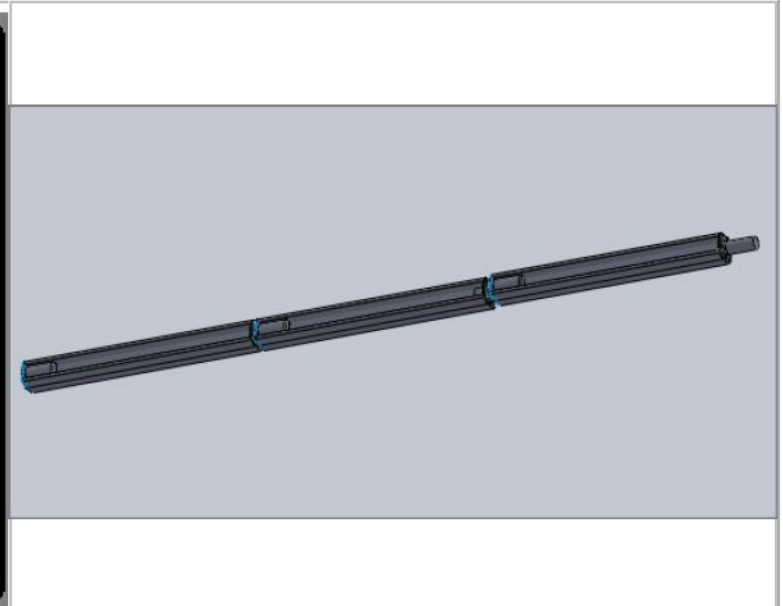



RhinoFabStudio®

- **Name:** Tutor for tomatoes plants.
- **Email:** ingarturo@gmail.com, itoledoh@utrng.edu.mx
- **Company:** UTRNG
- **Website:** www.utrng.edu.mx
- **City:** Iguala, Gro.
- **Country:** Mexico



• **Project Info:** In several crops are used tutors (large stick) between the plants grow, most of the times in México they use oate trees, in this project we designed and builded a mold for a modular tutor made of recycled plastic. Designed in Rhino and the CNC code was made in RhinoCAM and the mold was build in steel, using the VMC Hass VF1

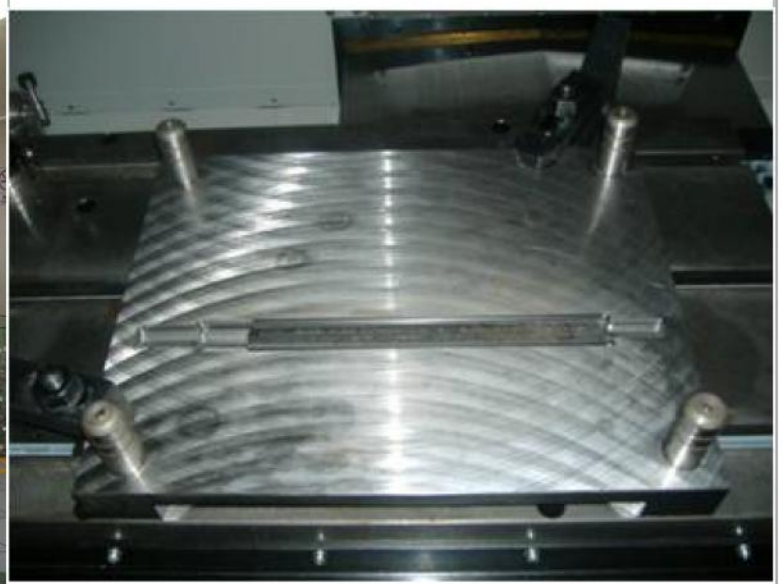



•Name: Coral Ring •Email: alealfaro@tec.mx

•Company: Tec de Monterrey •Website: www.gda.itesm.mx/concentraciondejoyeria/

•City: Guadalajara, Jalisco •Country: México



•Project Info: Silver ring inspired by the natural growth of coral.

Class: Basic jewelry design and manufacturing techniques. Tecnológico de Monterrey

Designer Juan Carlos Banda / Professor PHD Alejandra Alfaro Suzán.

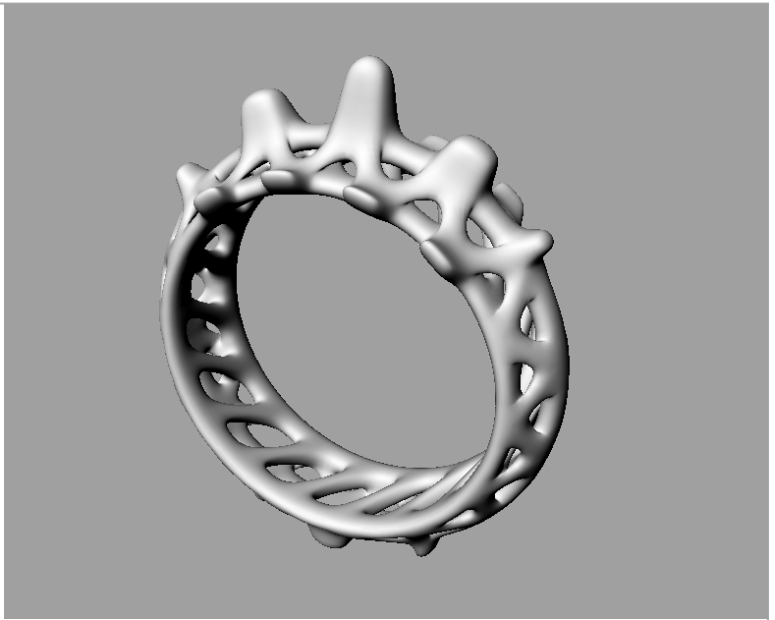



•Name: Ring •Email: alealfaro@tec.mx

•Company: Tec de Monterrey •Website: www.gda.itesm.mx/concentraciondejoyeria/

•City: Guadalajara, Jalisco •Country: México



•Project Info: Ring made using Rhinoceros for 3D printing and casted in silver.

Class: Basic jewelry design and manufacturing techniques. Tecnológico de Monterrey

Designer Diana López Caballero / Professor PHD Alejandra Alfaro Suzán.

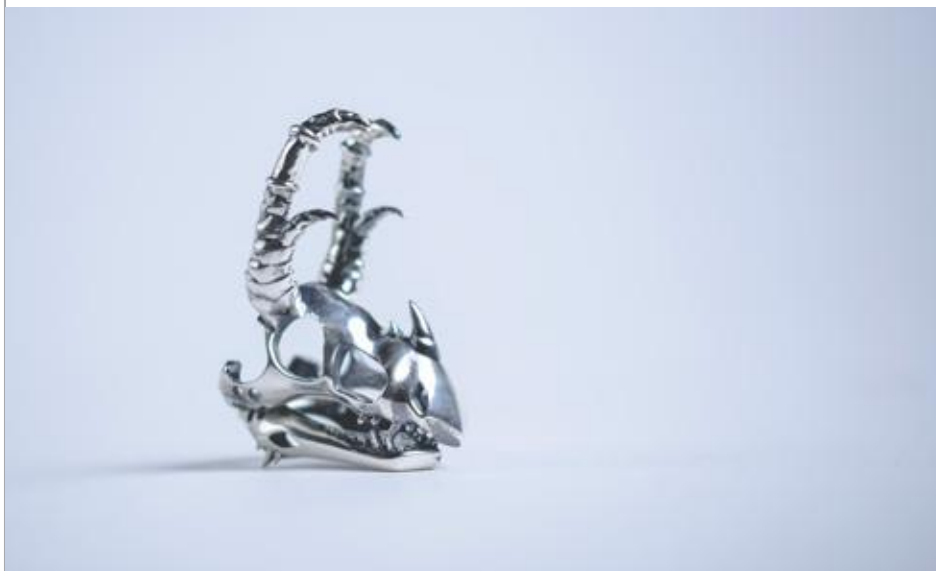



•Name: Hidden light

•Email: alealfaro@tec.mx

•Company: Tec de Monterrey

•Website: www.gda.itesm.mx/concentraciondejoyeria/

•City: Guadalajara, Jalisco

•Country: México



•Project Info: Silver ring with an internal hidden compartment for a LED mechanism.

Class: Basic jewelry design and manufacturing techniques. Tecnológico de Monterrey

Designer Omar Avilez / Professor PHD Alejandra Alfaro Suzán.

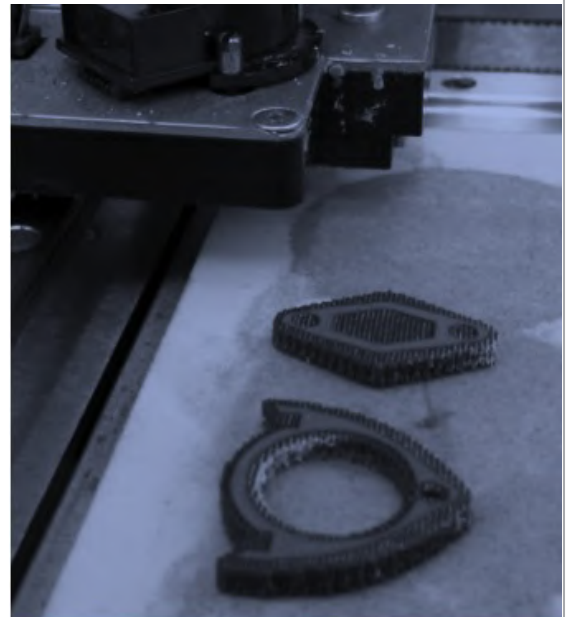
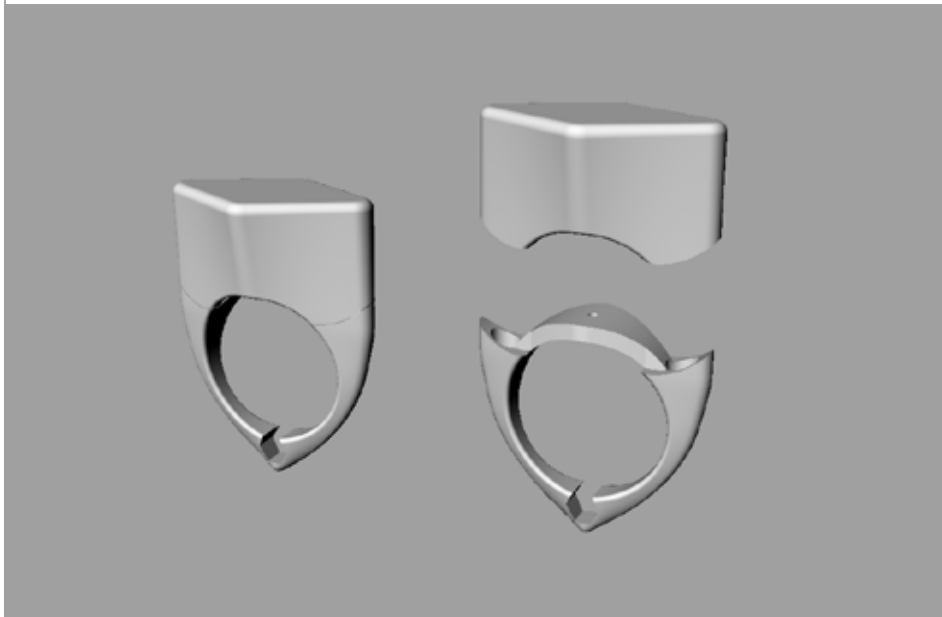



RhinoFabStudio®

- **Name:** Heart for chocolate mould
- **Email:** adrianjuarez@sicadcam.com
- **Company:** Servicios de Ingeniería CAD-CAM
- **Website:** www.sicadcam.com
- **City:** Ciudad de México
- **Country:** México
- **Project Info:** Heart made of zamac for chocolate injection mold, RhinoCeros modeling, RhinoCam machining on SICONO CNC machine

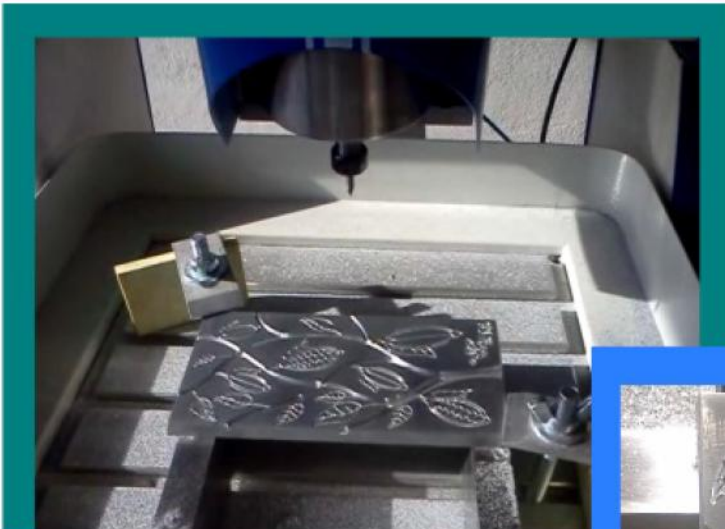



RhinoFabStudio®

• **Name:** Wax injection mould for jewellery • **Email:** adrianjuarez@sicadcam.com

• **Company:** Servicios de Ingeniería CAD-CAM • **Website:** www.sicadcam.com

• **City:** Ciudad de México • **Country:** México



• **Project Info:** Mold made of polyurethane resin to inject wax for lost wax casting in jewelry, RhinoCeros modeling, RhinoCam machining on SICONO CNC machine

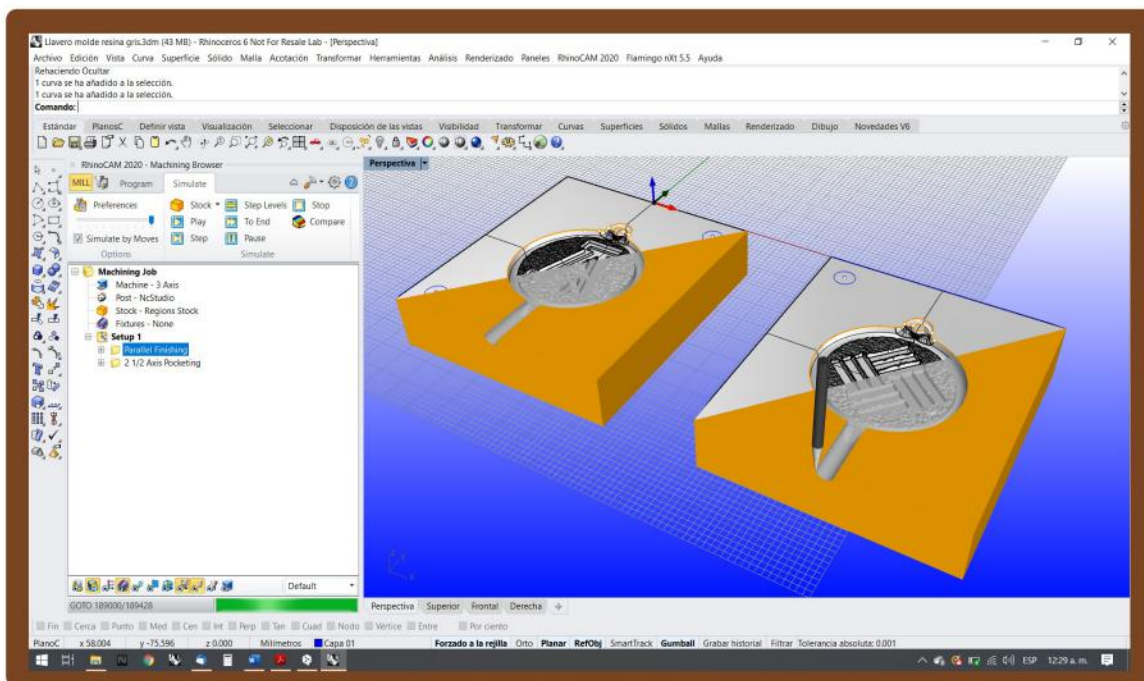



RhinoFabStudio®

- **Name:** Steel hot stamping die
- **Email:** adrianjuarez@sicadcam.com
- **Company:** Servicios de Ingeniería CAD-CAM
- **Website:** www.sicadcam.com
- **City:** Ciudad de México
- **Country:** México
- **Project Info:** Steel hot stamping die, RhinoCeros modeling, RhinoCam machining on the SICONO CNC machine

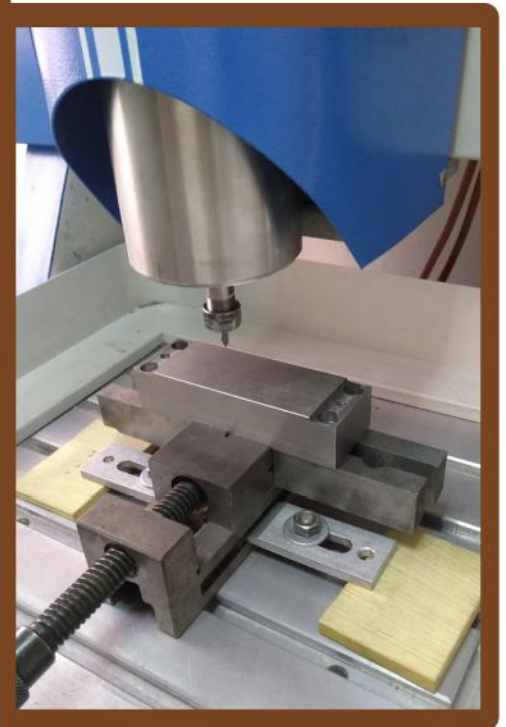
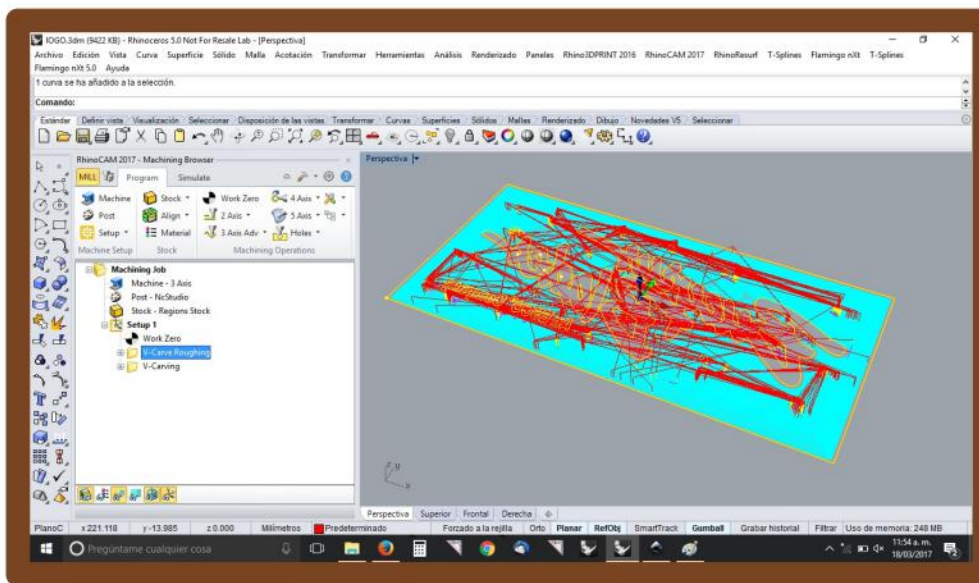



RhinoFabStudio®

- **Name:** Bicycles cut in the FabStudio
- **Email:** ovidio@mcneel.com
- **Company:** RhinoFabStudio UPB
- **Website:** http://rhino3dcolombia.ning.com
- **City:** Medellín
- **Country:** Colombia
- **Project Info:** Between GW (Colombian private bicycle company), F&C (wood seller) and Área Metropolitana (government entity), Tour Pura Vida in research partnership with UPB and RhinoFabStudio.



Universidad
Pontificia
Bolivariana
ESCUELA DE ARQUITECTURA Y DISEÑO



RhinoFabStudio™

- **Name:** Bicycles cut in the FabStudio
- **Email:** ovidio@mcneel.com
- **Company:** RhinoFabStudio UPB
- **Website:** <http://rhino3dcolombia.ning.com>
- **City:** Medellín
- **Country:** Colombia
- **Project Info:** Between GW (Colombian private bicycle company), F&C (wood seller) and Área Metropolitana (government entity), Tour Pura Vida in research partnership with UPB and RhinoFabStudio.





RhinoFabStudio®

•Name: Grasshopper chair

•Email: ovidio@mcneel.com

•Company: RhinoFabStudio UPB

•Website: http://rhino3dcolombia.ning.com

•City: Medellín

•Country: Colombia



•Project Info: Final Grasshopper class project. Teacher: Jose Ovidio Cardona. Students: Juan Camilo

Bermúdez / Juan Fernando Estrada / Andrés Palacio / Luisa María Hernández / Natalia Milena

Naranjo / Mateo Zuluaga





•Name: Morfolámparas

•Email: ovidio@mcneel.com

•Company: RhinoFabStudio UPB

•Website: http://rhino3dcolombia.ning.com

•City: Medellín

•Country: Colombia



•Project Info: Final class project: Flexibility of rigid sheets through experimentation with laser cutting. Teacher:

Andrés Valencia y David Torreblanca / Students of the class: Optativa en Morfología

Experimental.

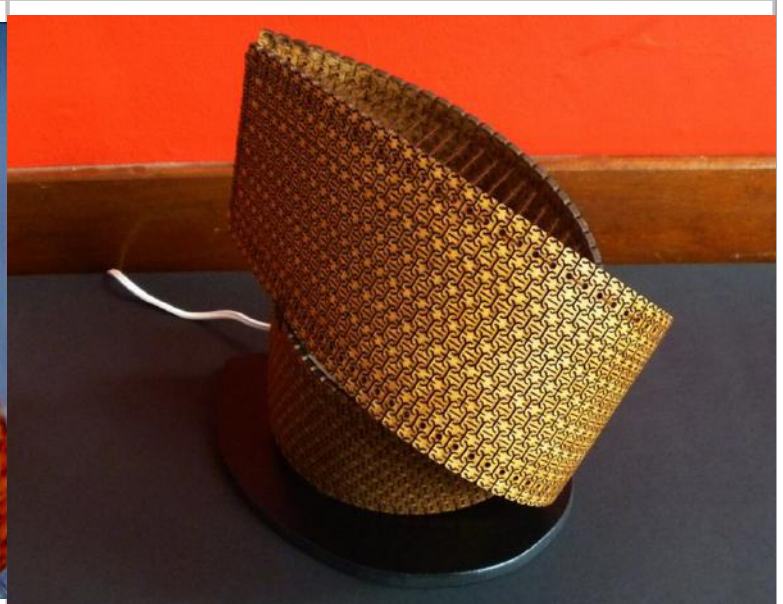



+ *InstituteForComputationalDesign*
+ *Claudia Del Priore*
+ *Sapienza Design Factory*
+ *Controlmad*
+ *Antonio Turiello*

+ *Siemen Cuypers*
+ *RM Gioielli*
+ *AUREASERVICE Design Studio*
+ *Fablab Catania*

By ARTs, ARTCs, and RhinoFabStudios®



RhinoFabStudio®

• **Name:** Claudia Del Priore

• **Email:** claudia@claudiadelpriore.com

• **Company:** Claudia Del Priore

• **Website:** www.claudiadelpriore.com

• **City:** Lausanne

• **Country:** Switzerland



• **Project Info:** Deep Blue is a collection where the circular shape and white and blue colors predominate. The sky, the ocean, diamonds and sapphires, the white and blue combination that is so good for our eyes. Created with Rhinoceros, Rhinogold and rendered with Brazil.

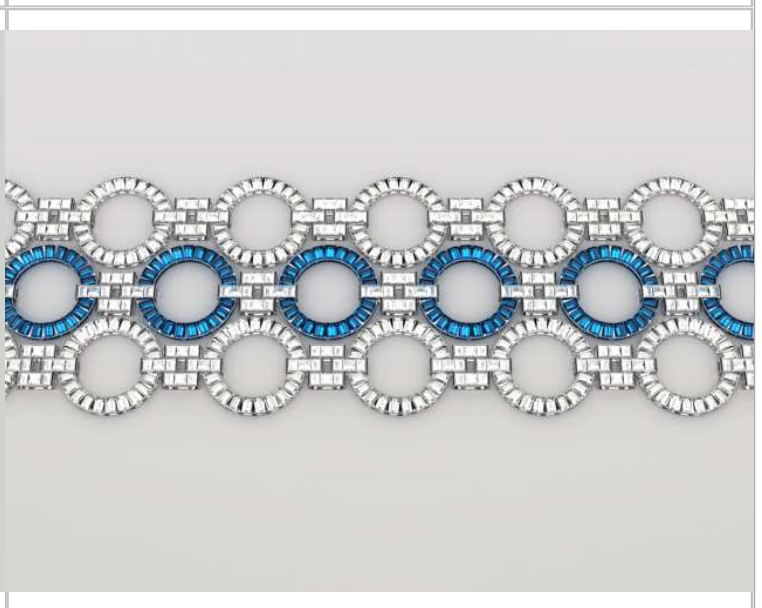



RhinoFabStudio®

- **Name:** Claudia Del Priore
- **Email:** claudia@claudiadelpriore.com
- **Company:** Claudia Del Priore
- **Website:** www.claudiadelpriore.com
- **City:** Lausanne
- **Country:** Switzerland



• **Project Info:** Watches collection (Honeycomb model and Arcturus model). Created with Rhinoceros and Rhinogold. Grasshopper was used to create the honeycomb cells.





Rhino**Fab**Studio[®]

- **Name:** BUGA Fibre Pavilion
- **Email:** serban.bodea@icd.uni-stuttgart.de
- **Company:** InstituteForComputationalDesign
- **Website:** www.icd.uni-stuttgart.de/?p=22271
- **City:** Stuttgart
- **Country:** Germany



• **Project Info:** Rhino and Grasshopper were used in design and simulation to develop the potential of additive manufacturing of large-scale, core-less fiber composite structures. Fast and highly automated robotic fabrication processes were numerically controlled directly from Rhino and Grasshopper.

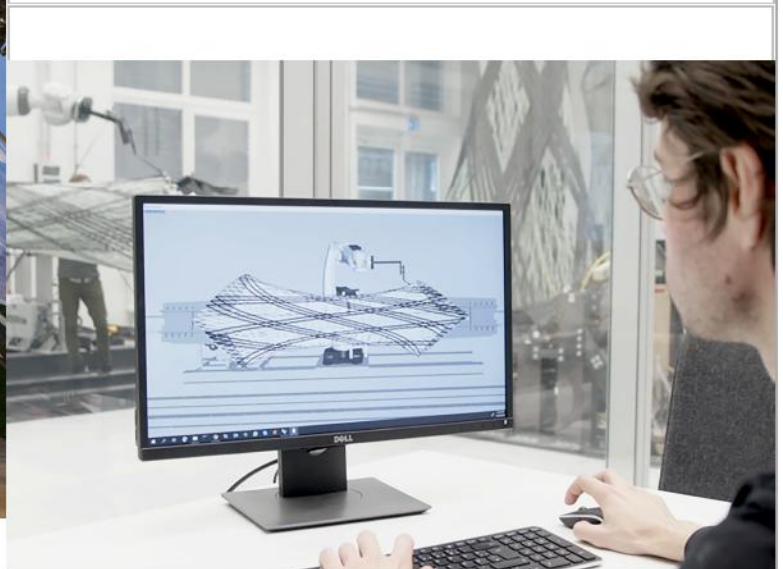
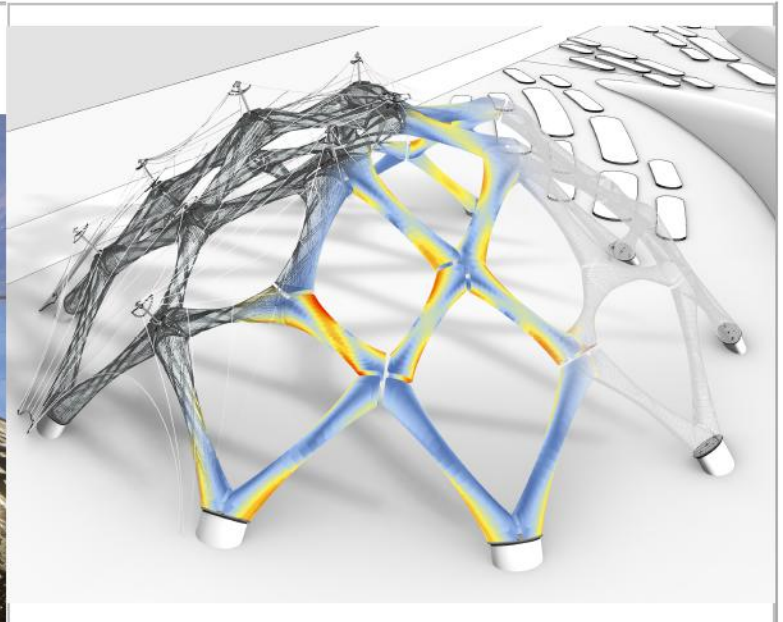
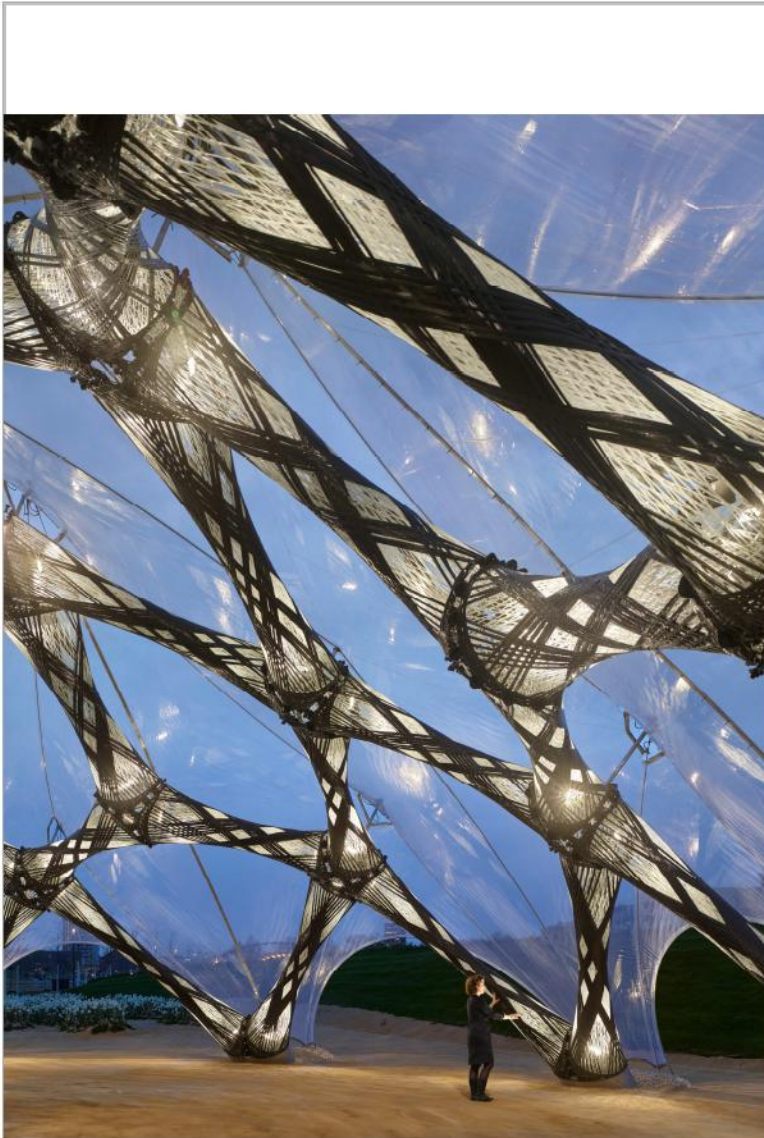



RhinoFabStudio®

• **Name:** DokiDoki Restaurant

• **Email:** info@controlmad.com

• **Company:** Controlmad

• **Website:** www.controlmad.com

• **City:** Madrid

• **Country:** Spain



• **Project Info:** Interior design of a japanese restaurant in Madrid. Furniture made of pinetree plywood milled with our 3 axis CNC milling machine. Designed, manufactured and finished by controlmad. If you like design and good japanese food this is your place.





RhinoFabStudio®

• **Name:** Benches for Ikea Group Valladolid

• **Email:** info@controlmad.com

• **Company:** Controlmad

• **Website:** www.controlmad.com

• **City:** Madrid

• **Country:** Spain



• **Project Info:** Two benches for Ikea at Rio Shopping mall in Valladolid (Spain). Plywood 21mm. Designed by controlmad in collaboration with Eriné Vardanyan. Manufactured by controlmad.





RhinoFabStudio[®]

• **Name:** Rooftop

• **Email:** info@controlmad.com

• **Company:** Controlmad

• **Website:** www.controlmad.com

• **City:** Madrid

• **Country:** Spain



• **Project Info:** This project creates a system of pieces in two directions where the client decides if he prefers a sofa, plants or as in the example, a bbq. The material is a type of wood-cement board suitable for exterior.





RhinoFabStudio®

- **Name:** Siemen Cuypers
- **Email:** siemencuypers@gmail.com
- **Company:** Siemen Cuypers
- **Website:** www.siemencuypers.com
- **City:** Oslo
- **Country:** Norway



• **Project Info:** An award for the winner of Oslo Innovation Week consisting of a Plastic Casting mold and the winner casted in recycled plastic from the Norwegian marine industry. The design and the code that runs the CNC-machine was made & generated using Rhino & Grasshopper.

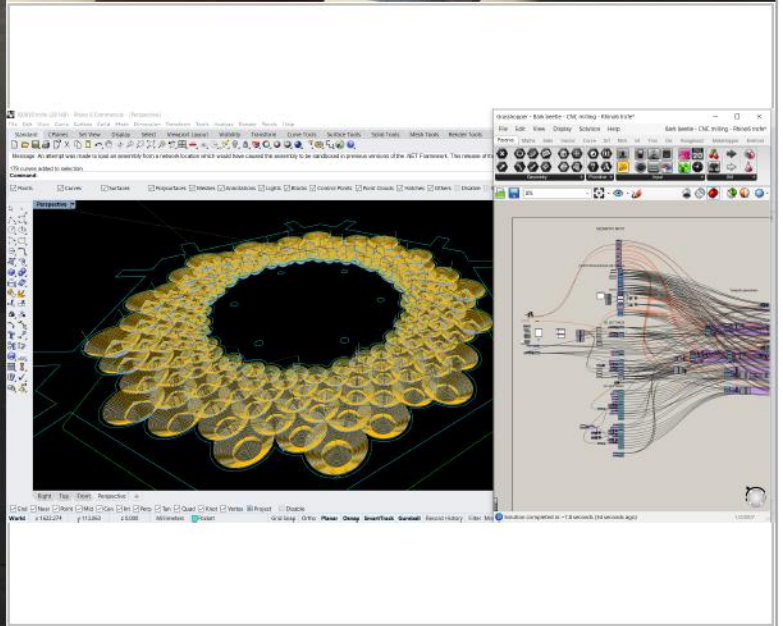
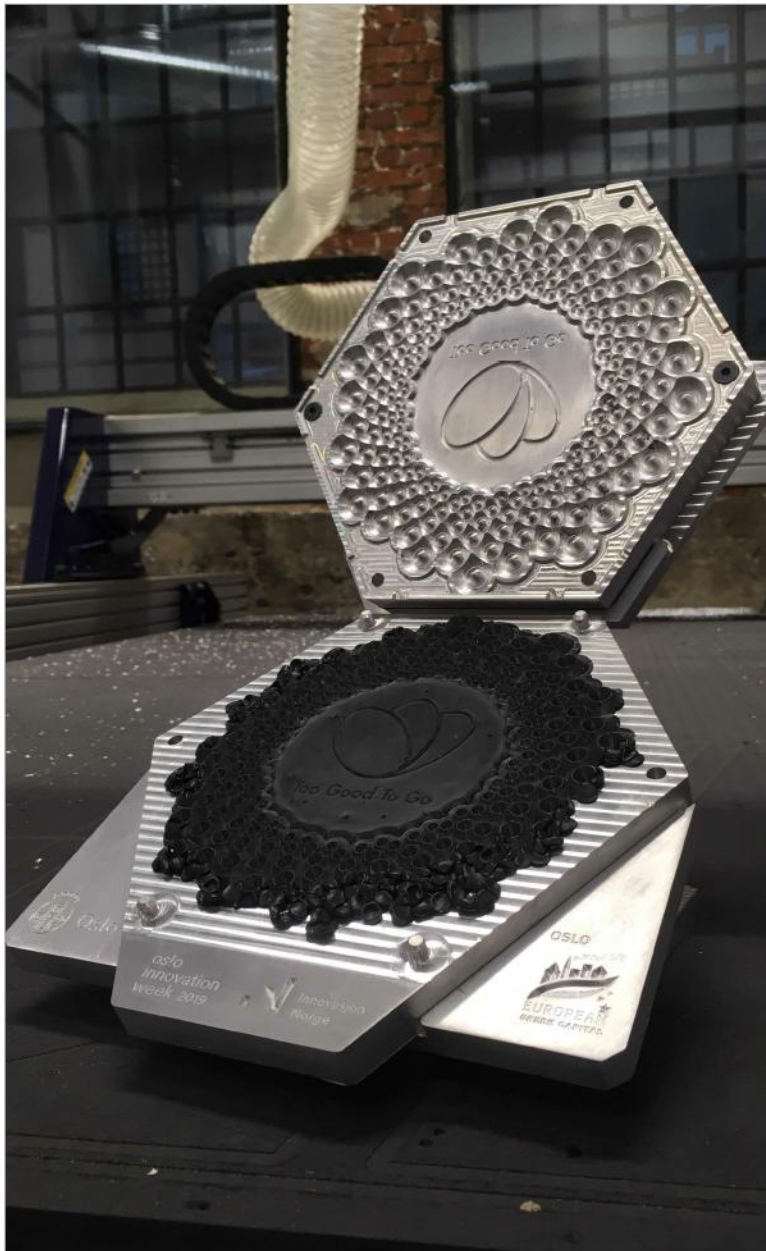



RhinoFabStudio®

• **Name:** LIGHTINVERSE

• **Email:** antonioturIELlo.blog@gmail.com

• **Company:** Antonio Turiello

• **Website:** antonioturIELlo.blogspot.com

• **City:** Salerno, Campania

• **Country:** Italia



Authorized
Rhino
Trainer
webGHAdmin
DESIGNER 3D

antonioturIELlo.blogspot.it

• **Project Info:** LIGHTINVERSE is a street furniture prototype (bollard light) thought to be water jet cut in steel.

Grasshopper was used in the parametric design of the idea and Rhinoceros in digital fabrication.

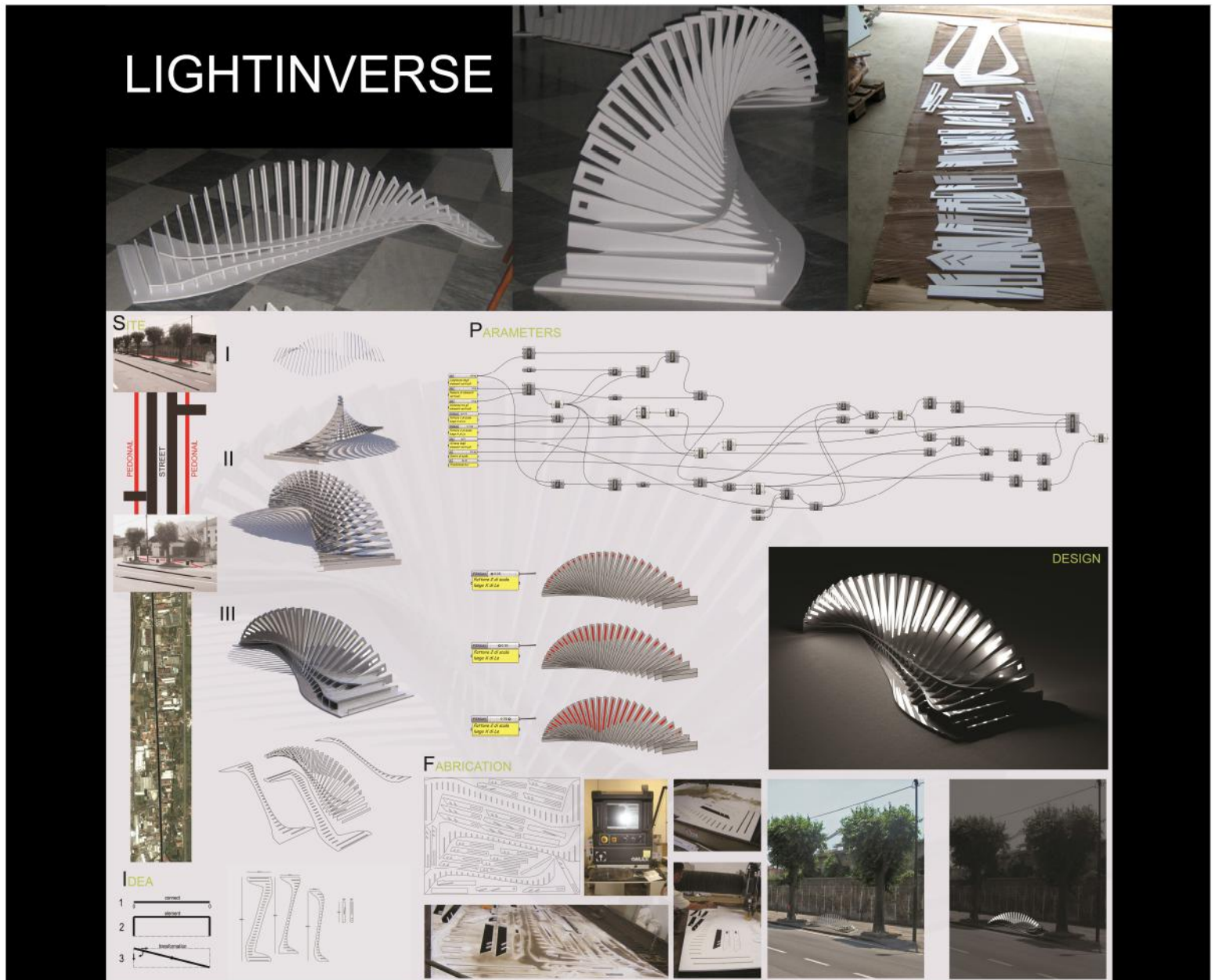



Rhino**Fab**Studio®

• **Name:** MOLECULART

• **Email:** antonioturIELlo.blog@gmail.com

• **Company:** Antonio Turiello

• **Website:** antonioturIELlo.blogspot.com

• **City:** Salerno, Campania

• **Country:** Italia

• **Project Info:** MOLECULART is a generative art sculpture (molecular geometry inspired) in laser cut MDF wood.

Rhinoceros and Grasshopper have been used in the first phase of the generation process called generative digital fabrication.



MOLECULART

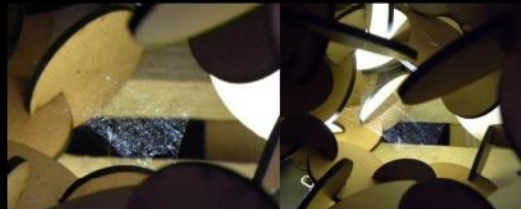

MoleculArt

GEOMETRIA MOLECOLARE (ISPIRAZIONE)

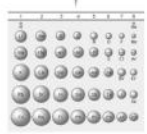

Arte generativa ispirata alla geometria molecolare: l'opera prende forma a partire da un processo che interpreta legami (angoli) tra atomi (raggi) come connessioni geometriche mutevoli tra regole e casualità.

Nella prima fase di questo processo avviene la fabbricazione computerizzata (generazione digitale) degli elementi, tutti diversi, da congiungere entro variazioni possibili di unione degli stessi. I quali poi nella seconda fase del medesimo processo vengono assemblati dall'artista (generazione analogica) che compone l'opera con proprie scelte casuali all'interno di una logica di posizionamento. Il risultato di questo algoritmo generativo digitale-analogico è una proliferazione nello spazio tridimensionale da cui emerge, con un dato livello di complessità, una delle infinite configurazioni possibili controllate ma non del tutto prevedibili nella forma finale che è riconoscibile ed irripetibile.

RAGGI ATOMICI ED ANGOLI DI LEGAME (VARIAZIONI)



DAL PIANO ALLO SPAZIO (SEMPLICITÀ COSTRUTTIVA)

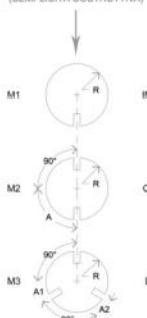

3 MODULI TIPO (ELEMENTI PIANI AD INCASTRO)

PARAMETRI (DOMINI)

$20 \text{ mm} \leq R \leq (2 \cdot 20) \text{ mm}$
 $0^\circ \leq A \leq 90^\circ$
 $0^\circ \leq A1 \leq 30^\circ$
 $0^\circ \leq A2 \leq (60^\circ - A1)$

NUMERO DI ELEMENTI

$M1 \times [2N + 1 - (N - 1)]$
 $M2 \times (2N + 1)$
 $M3 \times N$

INTERRUZIONE

CONNESSIONE

DIRAMAZIONE

REGOLE

DNA (IDENTITÀ)

CASUALITÀ

FABBRICAZIONE DIGITALE GENERATIVA

RHINOCEROS + GRASSHOPPER + GENERATION + VECTORIALISM

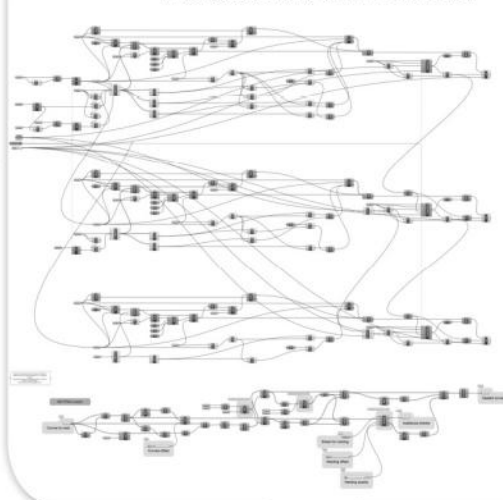

403 elementi con N = 100 (Pannelli MDF con spessore di 4 mm tagliati a laser)

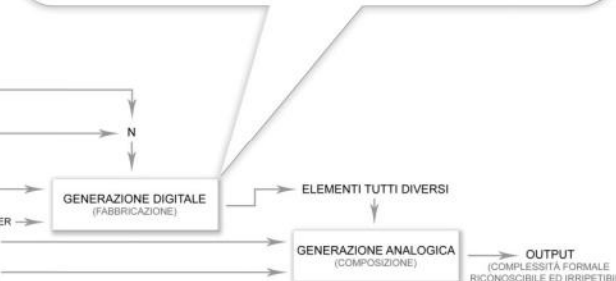

INPUT (LIVELLO DI COMPLESSITÀ)

MOELLAZIONE

COMPUTER

ASSEMBLAGGIO

ARTISTA

GENERAZIONE DIGITALE (FABBRICAZIONE)

ELEMENTI TUTTI DIVERSI

GENERAZIONE ANALOGICA (COMPOSIZIONE)

OUTPUT (COMPLESSITÀ FORMALE RICONOSCIBILE ED IRRIPIETIBILE)



- **Name:** ORGANICUBE
- **Email:** antonioturiello.blog@gmail.com
- **Company:** Antonio Turiello
- **Website:** antonioturiello.blogspot.com
- **City:** Salerno, Campania
- **Country:** Italia
- **Project Info:** ORGANICUBE is a design product (penholder) in SLS 3d printed polyamide.



Rhinoceros and Grasshopper have been used in the 3d model configuration process.

ORGANICUBE

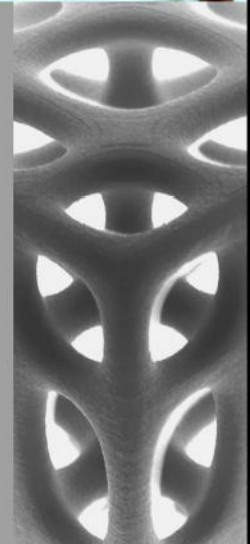
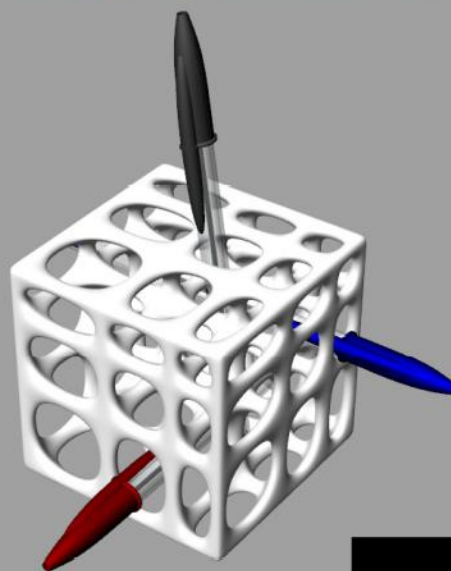
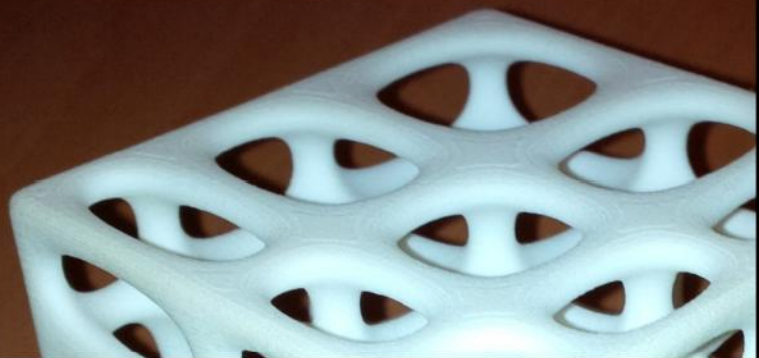
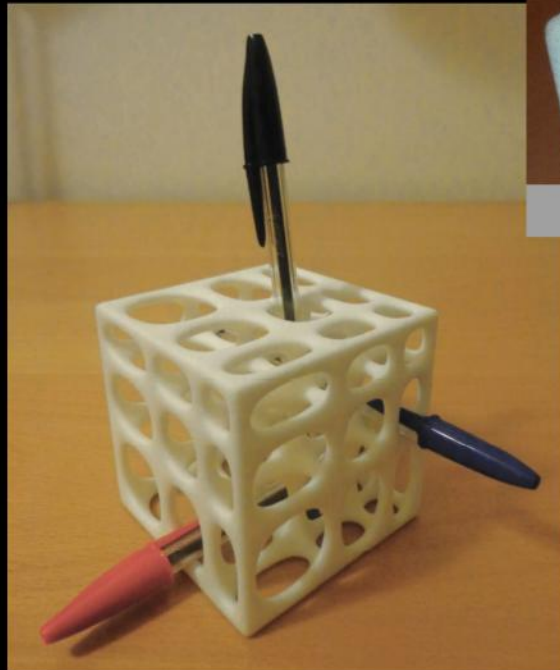

• GENERATOR

FRONT_TOP	<input type="checkbox"/>	3
FRONT_RIGHT	<input type="checkbox"/>	3
F_T_SHUFFLE	<input type="checkbox"/>	2
F_R_SHUFFLE	<input type="checkbox"/>	2
T_R_SHUFFLE	<input type="checkbox"/>	2
RANDOMIZE	<input type="checkbox"/>	

Close Controls

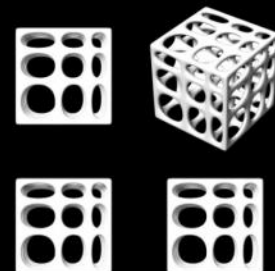



Rhino**Fab**Studio[®]

• **Name:** Golden Lace Band

• **Email:** info@areaservice.it

• **Company:** AUREASERVICE Design Studio

• **Website:** www.aareaservice.it

• **City:** Albizzate (VA)

• **Country:** Italy



• **Project Info:** New concept band in white, yellow and pink gold. Modeled in Rhino and Grasshopper with
Paneling Tools components

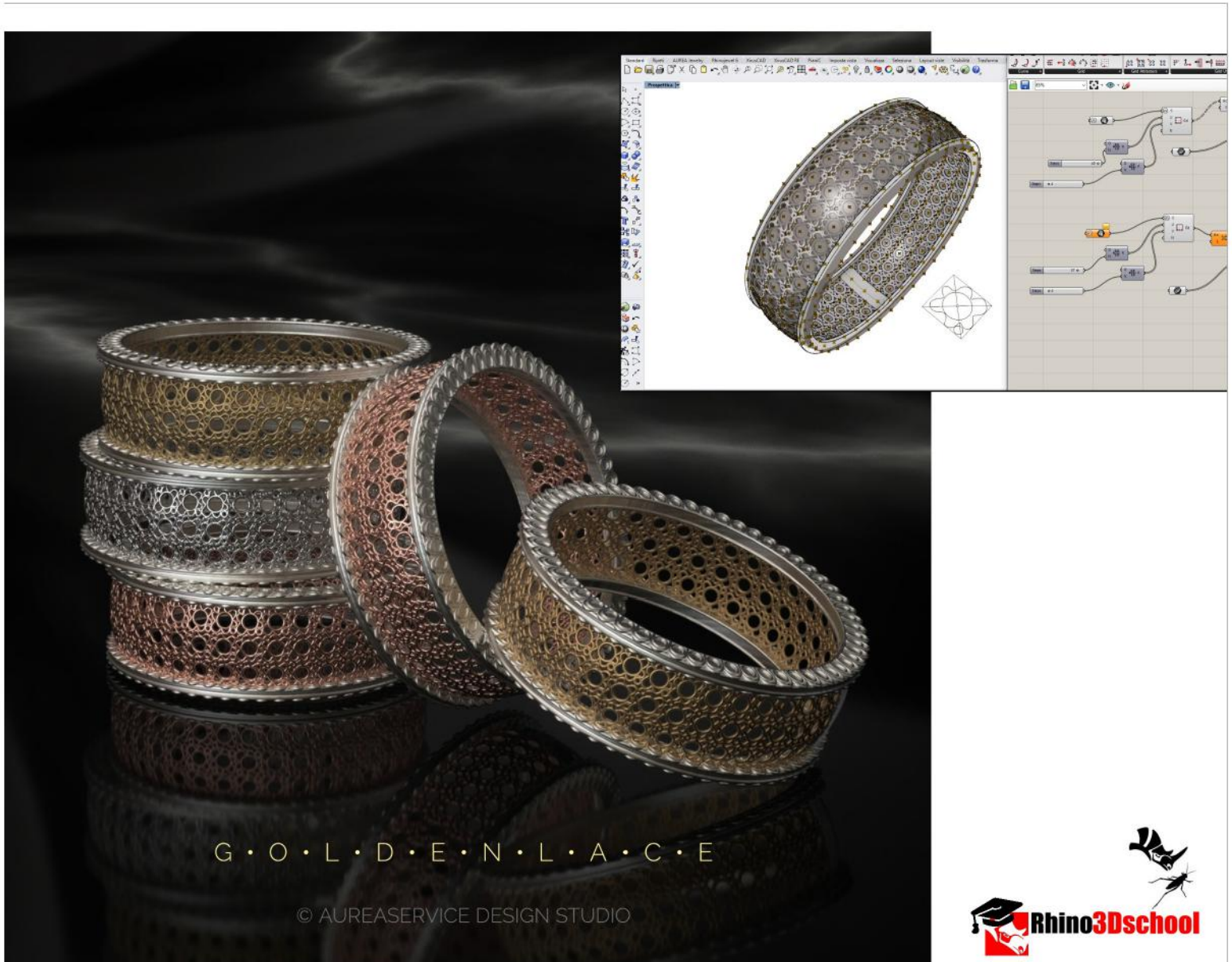



RhinoFabStudio®

• **Name:** Light Butterfly | Pencils Holder • **Email:** info@areaservice.it

• **Company:** AUREASERVICE Design Studio • **Website:** www.aareaservice.it

• **City:** Albizzate (VA) • **Country:** Italy



• **Project Info:** just an idea... the lightness of a butterfly: Pencils Holder modeled with Rhino SubD. FDM 3D Print with Woodfill filament

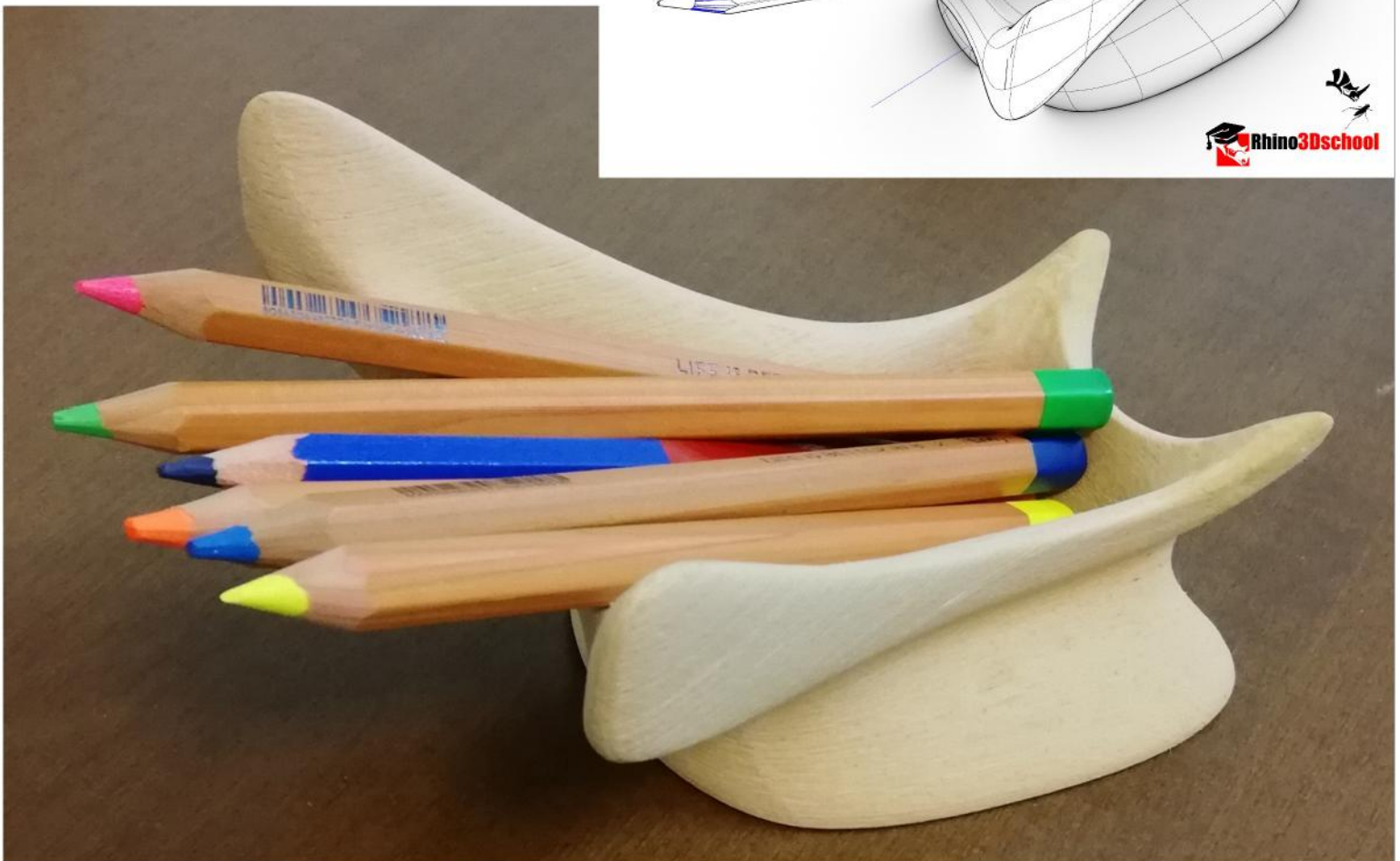
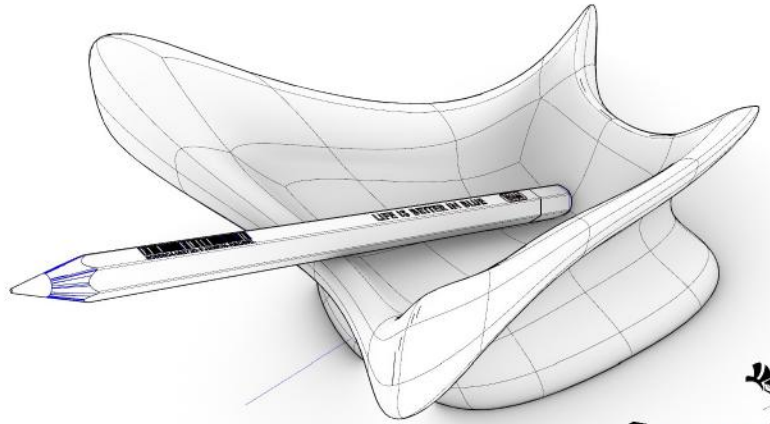
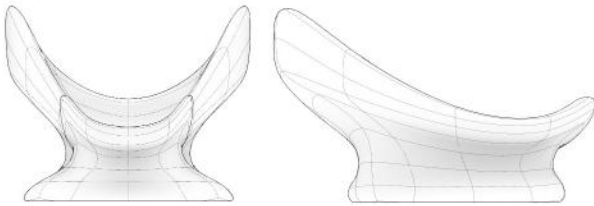



- **Name:** Virtualization Roman Fibula • **Email:** info@aureaservice.it
- **Company:** AUREASERVICE Design Studio • **Website:** www.aureaservice.it
- **City:** Albizzate (VA) • **Country:** Italy



• **Project Info:** This project is a collaboration with Museo Studi Patri (Gallarate-Italy): modeled in Rhino from
high resolution images of original (1st century a.C). 3D model will be kept printed scale 1: 1 in
bronzefill

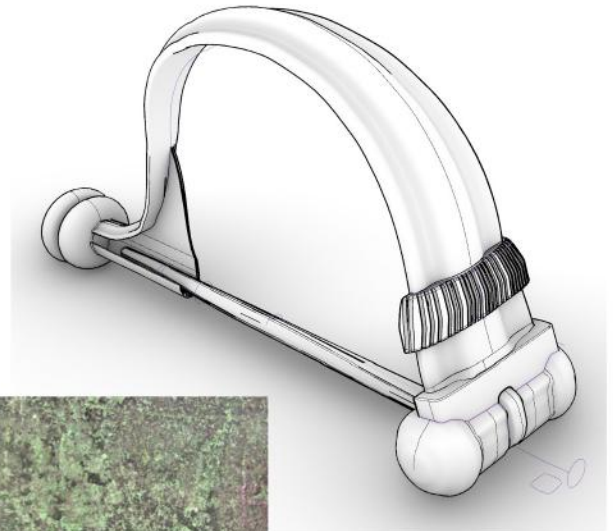
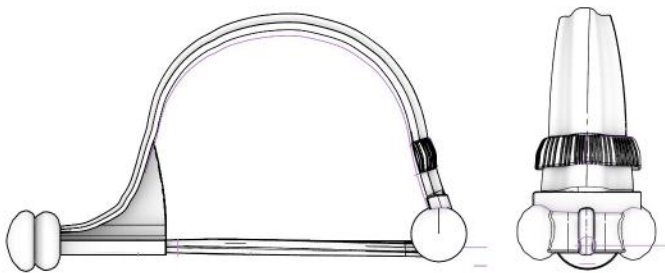

TEXTURING

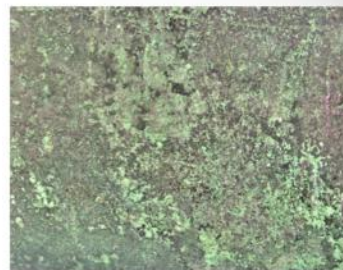

oxidized bronze

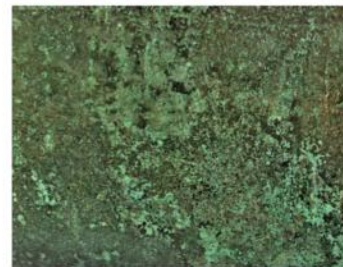

"saturated" bronze

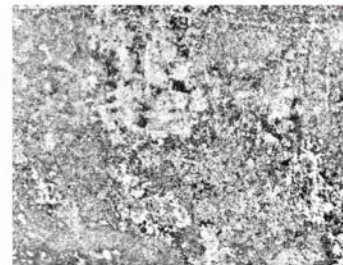

bump mapping



RhinoFabStudio®

Rhinoceros 6



• **Name:** LAURA MANDRELLI

• **Email:** lauramandrelli1961@gmail.com

• **Company:** RM Gioielli

• **Website:** robertomandrelli.wixsite.com

• **City:** ROMA

• **Country:** ITALY

• **Project Info:** Designed and engineered by Laura and Roberto Mandrelli
Artisans in Rome
Made with Rhonoceros 6
Render with Brazil

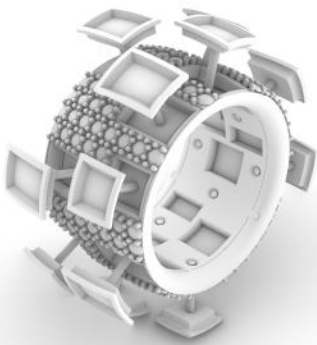



Rhino**Fab**Studio[®]

•Name: Kabuto

•Email: alex.coppola7@gmail.com

•Company: Sapienza Design Factory

•Website: alexcoppoladesign.com

•City: Rome

•Country: Italy



•Project Info: Kabuto is an electric guitar mostly designed in Grasshopper and fabricated through CNC milling and RhinoCAM by the research laboratory Sapienza Design Factory. The algorithm wants to be an AAD system for luthiery. This project is part of Alex Coppola's PhD Thesis "Digital Craft Factory".





RhinoFabStudio®

•Name: CARMEN RUSSO

•Email: CARMEN@FABLABCATANIA.EU

•Company: FABLAB CATANIA

•Website: FABLABCATANIA.EU

•City: CATANIA

•Country: ITALY



FABLAB
Catania

•Project Info: Lollipen (c) was born from the idea of combining a pen and a candy. has been tested by a Dutch speech therapist on children suffering from attention syndrome. The candy can be removed and replaced with a new one. it is washable. The project is looking for supporters and financiers.





• **Name:** Siemen Cuypers • **Email:** siemencuypers@gmail.com

• **Company:** Siemen Cuypers for Artisan Tech • **Website:** www.siemencuypers.com

• **City:** Oslo • **Country:** Norway



• **Project Info:** 2,4 x 2,4 x 0,6 meter working mechanical clock for the technical museum in Oslo. 3D-modeling, preparing CNC cutting files and assembly guides were made using Rhino. Calculating and drawing of the gears was done using Grasshopper.

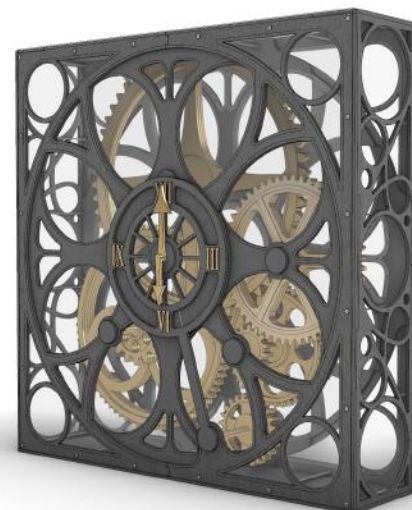



+ *Architechnologies, Inc.*
+ *Formforge*

By ARTs, ARTCs, and RhinoFabStudios[®]



Rhino**Fab**Studio[®]

• **Name:** Parametric Ceiling & Shelves

• **Email:** agdizon@thearchitechy.com

• **Company:** Architechnologies, Inc.

• **Website:** architechnologies.com

• **City:** Cebu City

• **Country:** Philippines



• **Project Info:** Ceiling installation and shelves designed with Rhino 6 and Grasshopper. Shelves were CNC cut with a Shopbot.

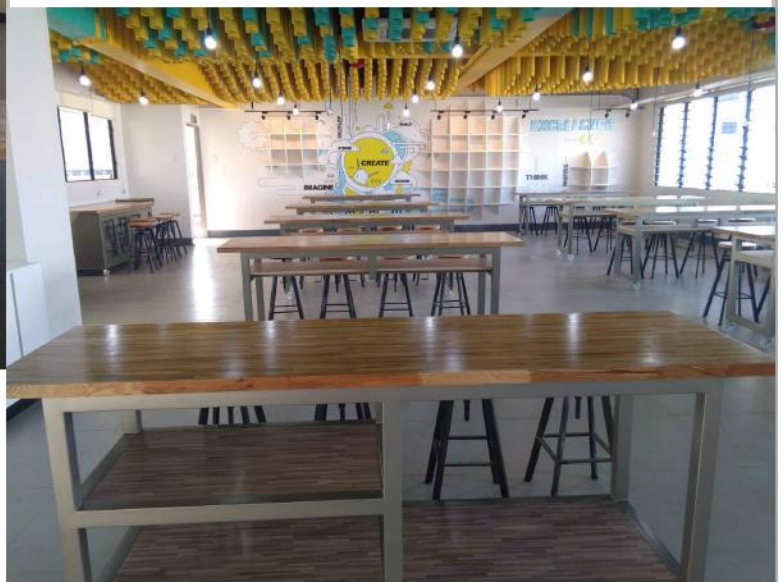
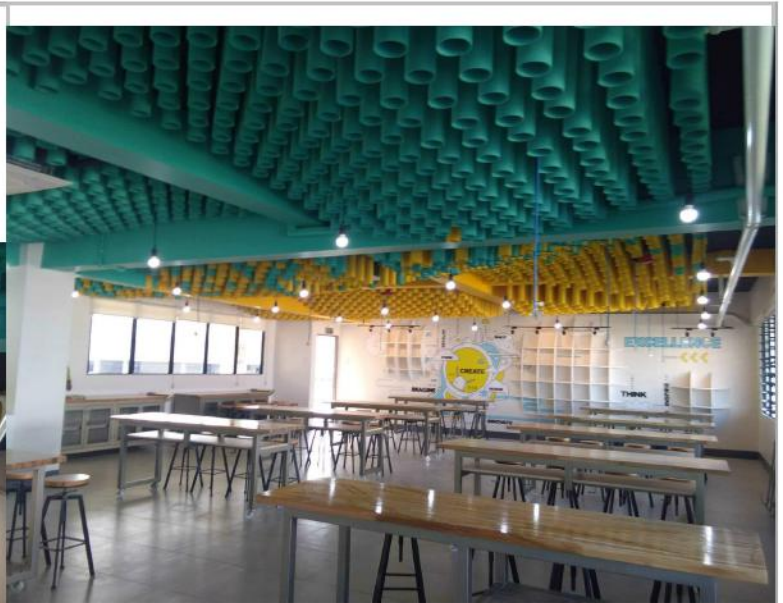
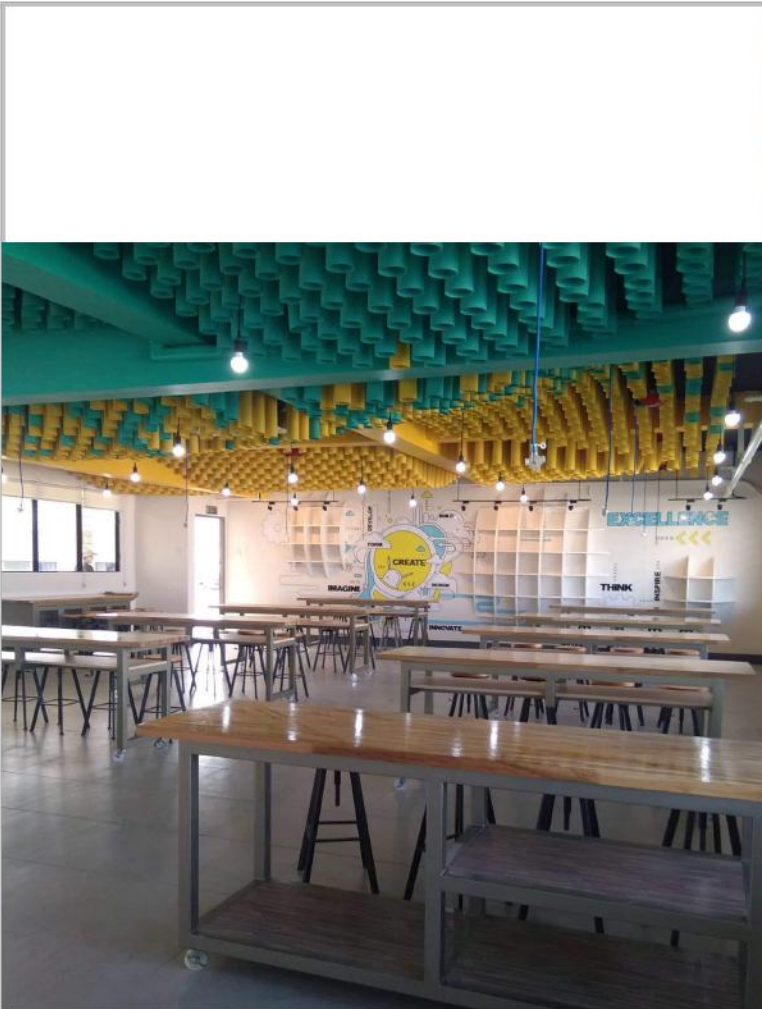



RhinoFabStudio®

• **Name:** Abhinav Goyal

• **Email:** info@formforge.co

• **Company:** Formforge

• **Website:** <https://www.formforge.co/>

• **City:** New Delhi

• **Country:** India

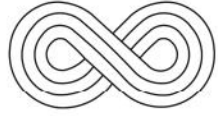

• **Project Info:** Ant hill emerges as a structure of continuum. It represents the layers of intricately carved rigid shapes. This installation showcases the digitized process, at the same time conceals its underlying formative forces to produce something that seems effortless. As the name suggests, the concept behind this installation is changing manifestations from solid to fluid, probing the question of what fluidity designates.

Dimension-16ft. x 8ft. x 1.2ft. Material- Birch Ply

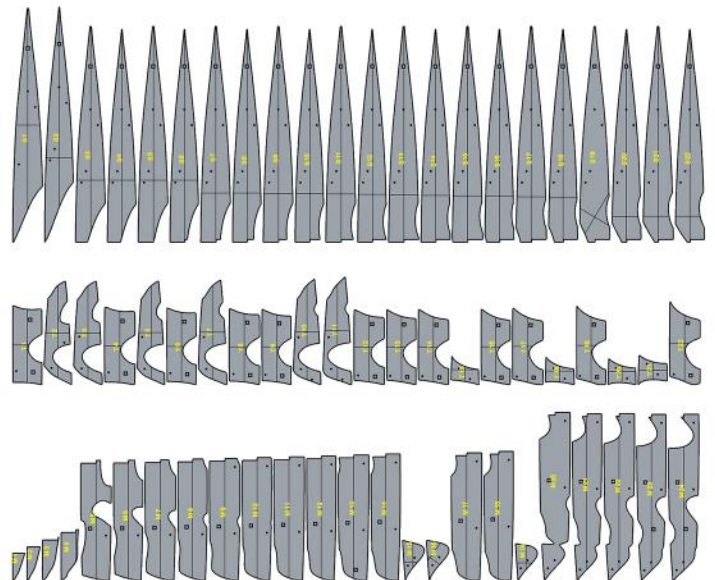
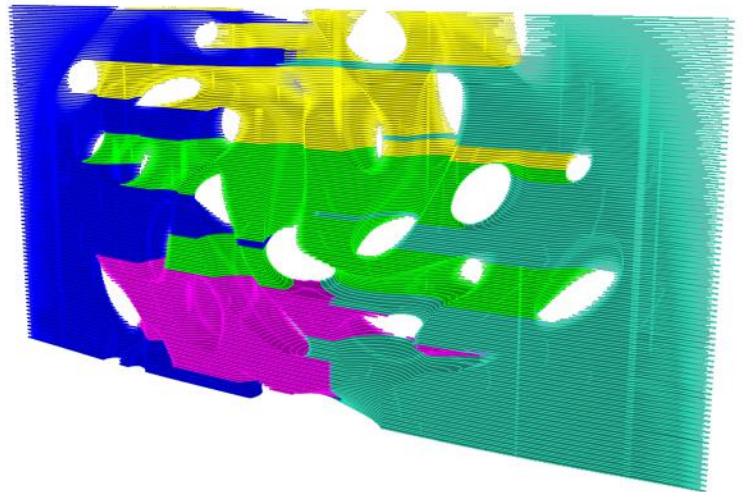



RhinoFabStudio®

• **Name:** Abhinav Goyal

• **Email:** info@formforge.co

• **Company:** Formforge

• **Website:** <https://www.formforge.co/>

• **City:** New Delhi

• **Country:** India

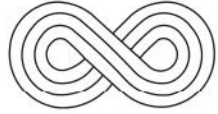

• **Project Info:** This statue is an ode to Mohandas Karamchand Gandhi, an Indian lawyer, anti-colonial nationalist, and political ethicist. It is sculpted and fabricated using algorithmic tools. The process used is slicing. All the unique laser cut pieces are fused together to form this complex and sophisticated statue. The output, hence, is highly detailed.

Dimension-7ft. x 4ft. x 4ft. Material- Birch Ply

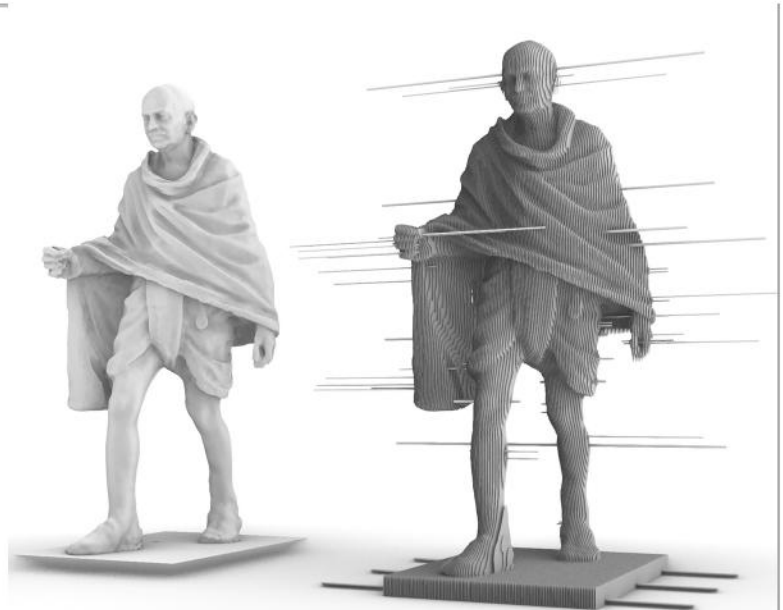



RhinoFabStudio®

• **Name:** Abhinav Goyal

• **Email:** info@formforge.co

• **Company:** Formforge

• **Website:** <https://www.formforge.co/>

• **City:** New Delhi

• **Country:** India

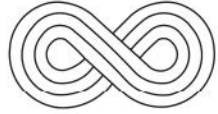

• **Project Info:** The design of Parachair is inspired by the phenomenon of rhythm, continuity and adaptation. The chair frame is constructed with one inch Ply Board, cut and milled with the help of 3axis CNC machine on a digitally generated pattern. Para chair is designed as responsive mass-customized furniture. Designed in computer platform the structure is scripted around 2 variables: The user's height and weight. The chair has two backbone panels and 45 unique components each numbered for its specific position. All the pieces are cut in CNC router and screwed together with the main frame.

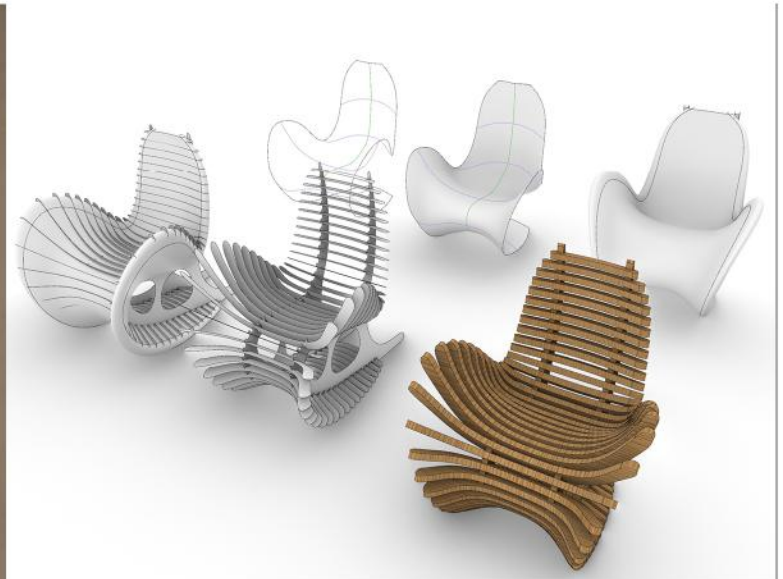



RhinoFabStudio®

• **Name:** Abhinav Goyal

• **Email:** info@formforge.co

• **Company:** Formforge

• **Website:** <https://www.formforge.co/>

• **City:** New Delhi

• **Country:** India



• **Project Info:** The Scorpion is a giant faceted sculpture located at in Hyderabad in an exotic cactus garden. This installation was done to complement the dry and arid nature of landscape with a contrasting corten steel finish. It weighs about 700 kg and 25 ft in length and 12 ft in height with open joints that illuminate in the evening. It constitutes 1475 unique faces with laser cut joints in stitch design. Dimensions- 20ft.x 10ft.x 12ft. Material- Corten steel

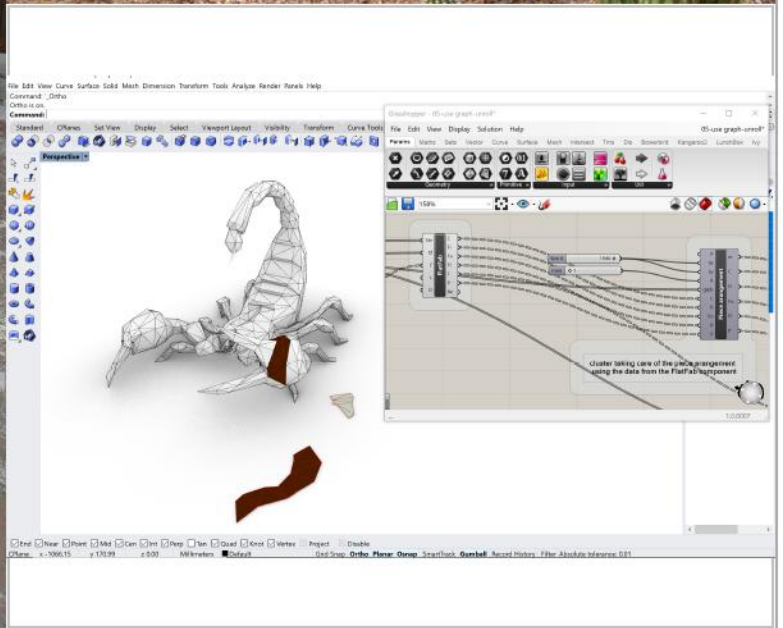

Digital fabrication

Showcase

By ARTs, ARTCs, and RhinoFabStudios®

