

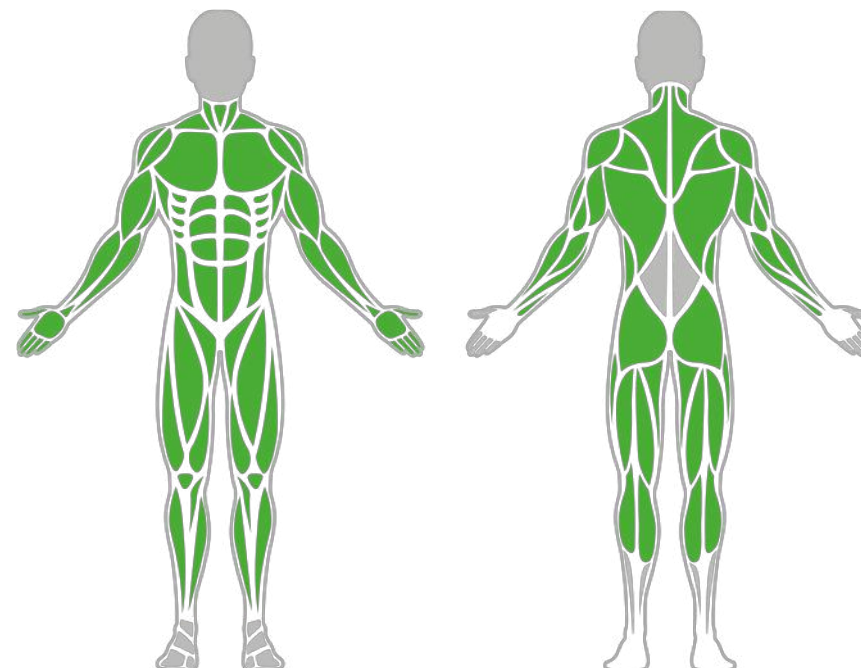

Muscle Groups Focus



Suspension Trainer 1900 930

The Suspension Trainer, with a 6' – 2.80" column and 3' – 0.61" ropes, supports diverse workouts from strength to flexibility. Suitable for all fitness levels, it's key for core, balance, and endurance enhancement.

Attributes

Product code	1-1-229
Certificate	EN 16630, ASTM F3101
Age group	14 + years
Capacity	1 person
Max. weight load	286.60 lbs
Type	Cross Training
Difficulty level	Easy

Side View

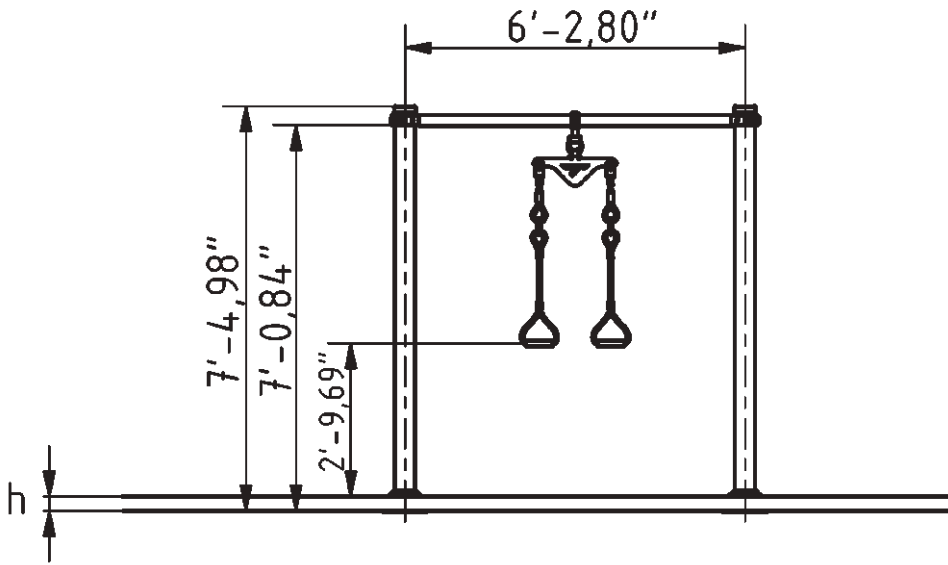

Plan View

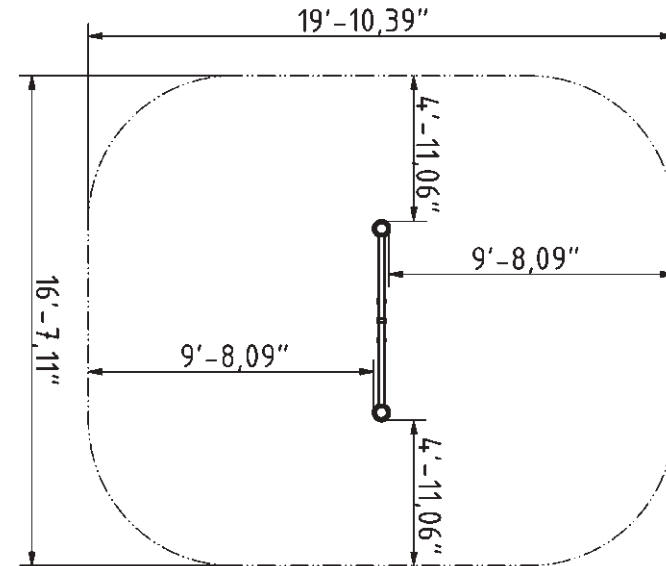

Installation information

Number of installers (concrete)	At least 2 people
Total installation time (concrete)	45-90 min.
Number of installers (equipment)	At least 2 people
Total installation time (equipment)	20-30 min.
Excavation volume	14.13 ft ³
Concrete volume	14.13 ft ³
Size of the base structure	2pc 19.69 x 19.69 x 31.5"
Anchoring options	In-ground or surface
In combined structures, the volume of concrete required varies.	

Technical specification

Safety surface area	Around 4.92 ft radius
Net weight	49 lbs
Material	S235
Critic fall height	-
Color options	
For more color options, discuss with your sales representative.	

Warranty

Structure	25 years
Steel	15 years
Paint	2 years
Plastic	5-10 years
Rubber	1-3 years
Moving parts	2 years
Detailed information in the warranty document	

Material specification

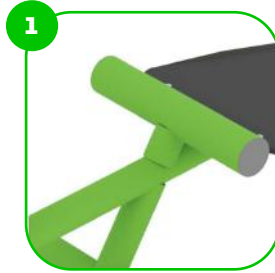
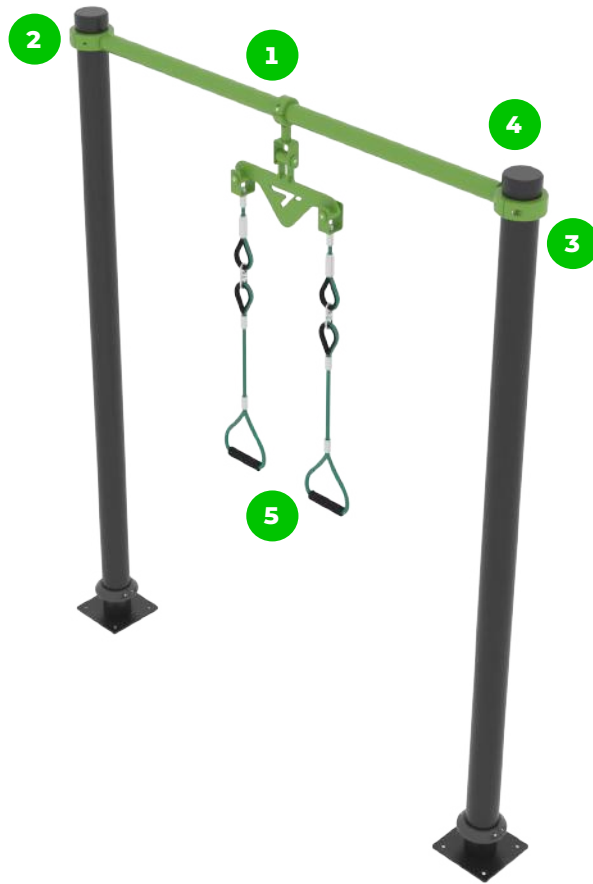

The element is made of high quality S235 steel, which has been cleaned via sandblasting. A corrosion resistant powder coating finish is then applied. Also available with galvanized surface for even greater protection and longevity!



The clamp system allows for easy assembly and extreme stability.



The connecting elements are fastened with vandal-proof stainless steel screws and nuts.



The ends of the bars and posts are sealed with injection-moulded plastic caps.



Steel ropes with a 0.63" diameter, galvanized and sheathed in nylon, are joined using connectors made of plastic. These ropes are UV radiation, abrasion, and rot-resistant.

BESTRONG

bestrongworld bestrongworld usa.bestrong.com usa@bestrong.com

