



TABLE OF CONTENTS

2 FROM THE BAR

- 3 Cocktails
- 4 Wine
- 5 Beer
- 6 Old Fashioned
- 7 General Spirits

10 ZERO PROOF MIXOLOGY

- 11 Mocktails & Liquid Gastronomy
- 12 Non-Alcoholic Wine & Beer
- 13 Botanicals, Adaptogenics & Sodas

14 DINING MENU

- 15 Snacks & Greens
- 16 Lounge Spreads
- 17 Mains
- 18 Z Exclusives
- 19 Sweets



FROM THE BAR

Crafted with care, poured with style and served in the enduring spirit of the classic hotel lounge, where time slows and conversation flows.

"You've got my blessing—'cause the right pour puts a shine on the soul and tucks your troubles in for the night."

— The Lounge Philosopher —



Vegan



Sustainable



Gluten Free



Organic



Biodynamic



ZORBA COCKTAILS

Melon Veil Light & Refreshing 20

Wheatley Vodka, Winter Melon Essence Prosecco, Midori

The Evening Calmness in the West Bright & Floral 20

Tesoro Tequila, Laird's Applejack Brandy, Chamomile, Blue Agave, Clove, Bitters

Solaris Drift Smoky & Tropical 20

Vida Mezcal, Giffard Banana Liqueur, Orgeat, Citrus

Kyoto Ember Quiet & Bold 20

Suntory 'Toki' Whisky, Mr. Black Coffee Liqueur, Campari Peychaud's Walnut Bitters

Moulári Fresh & Herbal 20

Verino Mastiha, Ouzo, Lime Juice, Ginger Beer, Citrus, Dried Fig

Negroni Nero Velvety & Dark 20

Malfy Gin, Campari, Carpano Antica, Averna Orange Swath

Espresso Martini Bold & Silky 20

Ketel One Vodka, Mr. Black Coffee Liqueur, Vanille de Madagascar, Lavazza Cold Brew

Vesper 007 Crisp & Iconic 20

Bombay Sapphire Gin, Grey Goose Vodka, Lillet Blanc, Citrus

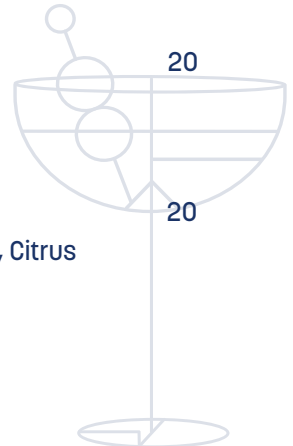



WINE

SPARKLING

Les Allies Blanc de Blanc, Brut 	15
Prosecco Brut Masottina, Veneto 	17
Michele Chiarlo Nivole Moscato d'Asti DOCG  	16





ROSÉ

Zenato Bardolino Chiaretto, Veneto  	15
---	----











ORANGE

Cirelli 'La Collina Biologica' Abruzzo   	16
---	----

WHITE

Sauvignon Blanc Pighin, Friuli-Venezia Giulia  	16
Chardonnay Duck Pond, Willamette  	18
Pinot Grigio Cantina, Tramin Alto Adige DOC  	16
Riesling Fess Parker, Santa Barbara 	15

RED

Merlot Lapostolle, 'Grand Selection', Rapel Valley   	18
Cabernet Sauvignon De Loach Vineyards, Mendocino  	21
Pinot Noir King Estate, 'Inscription', Willamette   	17
Malbec Piattelli Vineyards, 'Reserve' Mendoza  	15



Vegan



Sustainable



Gluten Free



Organic



Biodynamic



BEER

DOMESTIC & LOCAL

Revolution Brewing Anti-Hero IPA (6.7% ABV)	9
Yuengling Golden Ale (4.5% ABV)	9
Firestone Walker Cali Squeeze Blood Orange (4.5% ABV)	9
Noon Whistle Gummylicious Hazy IPA (6.2% ABV)	9
Two Brothers 'Prairie Path' Golden Ale (5.1% ABV) 	8
Coors Light Colorado (4.2% ABV)	7
Miller Lite Wisconsin (4.2% ABV)	7
Michelob Ultra Missouri (4.2% ABV)	7

IMPORTED

Heineken Netherlands (5.0% ABV)	8
Peroni Italy (5.1% ABV)	8
Stella Artois Belgium (5.0% ABV)	8
Corona Mexico (4.6% ABV)	8

SELTZERS

Penrose Brewing 'Seltz Up', Lemon Seltzer, Geneva (6.0% ABV)	9
Penrose Brewing Seasonal Seltzer, Geneva (6.0% ABV)	9
Rotating Seasonal Flavors	9

CIDER & STOUT

Samuel Smith Cider (5.0% ABV)	11
Samuel Smith Chocolate Stout (5.0% ABV)	10

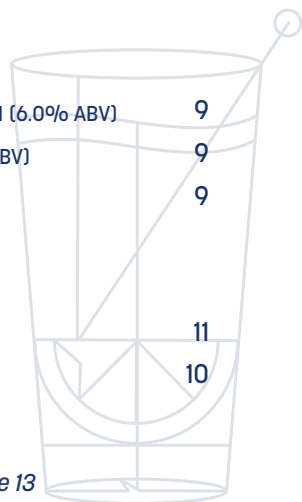

**non-alcoholic options available on page 13*



OLD FASHIONED

Built around your choice of bourbon or rye, our Old Fashioned layers warmth, citrus, spice and subtle sweetness into a cocktail that feels familiar, tastes exceptional and finishes clean.

BOURBON

Jim Beam Harmonious & Nuanced (40% ABV)	17
Old Forester Original & Innovative (43% ABV)	17
WhistlePig 'Snout & Tail' Summer Fruits & Baking Spices (44% ABV)	18
Buffalo Trace Sweet & Creamy (45% ABV)	19
Maker's Mark Sweet & Spicy (45% ABV)	19
Four Roses 'Small Batch' Smooth & Buttery (45% ABV)	19
Woodford Reserve Creamy & Warm (45.2% ABV)	21
Woodford Reserve 'Double Oaked' Bold & Sweet (45.2% ABV)	22
Baker's Single Barrel 7yr Bold & Rich (53.5% ABV)	24
Elijah Craig 'Barrel Proof' 11 yr Bold, Oakey & Warm (63.1% ABV)	26

RYE

Bulleit Smooth & Assertive (45% ABV)	20
WhistlePig 'Piggy Back' 6yr Bold & Spicy (48.28% ABV)	22
Sazerac Spice & Winter Fruit (51% ABV)	18

**add absinthe for the classic Sazerac (+\$2)*

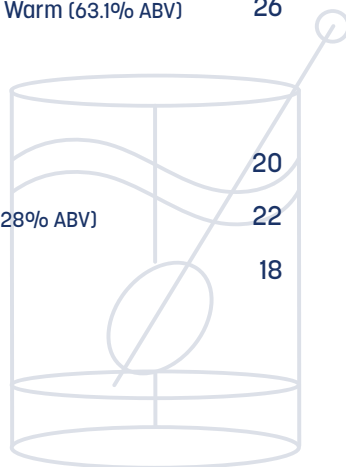

A close-up, low-angle shot of a hand in a brown leather glove pouring whiskey from a bottle into a glass. The glass contains a large ice cube and is partially filled with the golden liquid. The background is dark and textured, possibly a bar counter. The lighting is dramatic, highlighting the bottle's neck and the glass.

GENERAL
SPIRITS

From top-shelf legends to quiet showstoppers—if it belongs in a glass, it's here.

"Know thyself, pour thy spirit."

— The Lounge Philosopher —

SINGLE MALT WHISKEY

Ardbeg 10yr	24
Auchentoshan	16
Balvenie Oak 12yr	22
Balvenie Caribbean Cask 14yr	32
Caol ILA Single 12yr	24
Dalmore 12yr	22
Glenfiddich 12yr	16
Glenlivet 12yr	16
Lagavulin 16yr	26
Laphroaig	18
Macallan Sherry 12yr	34
Macallan DBL Oak 12yr	32
Macallan 15yr	72
Macallan 18yr	110
Magnus	16

JAPANESE WHISKEY

Toki	16
Hibiki Harmony	28
Yamazaki 18y (limited)	160
Yamazaki 12yr	60
Hakushu 12yr	38

BRANDY COGNAC ARMAGNAC

Lustau Solera Reserva (well)	16
Hennessy VSOP	18
Hennessy XO	42
Hine Rare & Antique	26
Lelouvier Calvados Fine	22
Pierre Ferrand 1840	20

BLENDED WHISKEY

Dewar's White Label (well)	15
Chivas Regal 12yr	16
Johnnie Walker Gold 18yr	36
Johnnie Walker Black	18
Johnnie Walker Blue	72
Johnnie Walker Red	15

PORTO MARSALA

Taylor 10yr	14
Dow's Tawny 10yr	16
Fonseca Porto Bin #27	19
Florio Marsala Superiore	16

BOURBON

Old Forester (well)	15
1792 Small Batch	16
Angel's Envy	18
Baker's	22
Bardstown (series)	18
Barton Very Old 100	21
Basil Hayden	15
Buffalo Trace	16
Bulleit	16
Crown Royal	14
Elijah Craig Small Batch	18
Four Roses Small Batch	16
Four Roses Single Barrel	24
Wild Turkey	16
Willett Pot Still	18
Woodford Reserve	16
Woodford Double Oak	22

GIN

Beefeater <i>(well)</i>	14
Bombay Sapphire	16
Hendrick's	16
Monkey 47	19
Nolet's	16
Tanqueray	14
Tanqueray 10	16
The Botanist Islay	16
The Lighthouse NZ	14

RUM

Bacardi Silver <i>(well)</i>	14
Cane Rock	16
Captain Morgan Original	14
Diplomatico Reserva	17
Clément Mahina Coco	14
Plantation 3 Star	14
Zacapa 23yr	18

RYE

Sazerac	16
Templeton Rye	22
WhistlePig 6yr 'Piggy Back'	18
WhistlePig 10yr	26
WhistlePig 12yr	35
WhistlePig 15yr	75
Boss Hog XII	225
Willett Small Batch Rye	18

SHERRY

Lustau Fino	14
Lustau Palo Cortado	18
Lustau Pedro Ximenez Solera	16

VODKA

Wheatley <i>(well)</i>	14
Belvedere	16
Grey Goose	16
Ketel One	16
Tito's	14
Vulcanica	16

TEQUILA

Corazón <i>(well)</i>	14
Casamigos Silver	14
Casamigos Reposado	16
Clase Azul Plata	28
Clase Azul Reposado	32
Don Julio 1942	38
El Tesoro Blanco	16
El Tesoro Reposado	18
Fortaleza Blanco	26
Fortaleza Reposado	32
Fortaleza Añejo	42
G4 Blanco	16
Mijenta Blanco	14
Mijenta Reposado	16
Tequila Ocho Blanco	17
Tequila Ocho Reposado	21

MEZCAL

Del Maguey Vida	16
Casamigos Mezcal	18

IRISH WHISKEY

Jameson	15
RedBreast 12yr	17



ZERO PROOF MIXOLOGY

Our spirit-free creations are crafted with the same care, balance, and style as our cocktails, blending botanicals, fresh juices, and adaptogenic ingredients into drinks that lift the mood without the proof.

*“Balance, my friend, is the mark of wisdom—
and the sharpest look in the room.”*

— The Lounge Philosopher —



Vegan



Sustainable



Gluten Free



Organic



Biodynamic

MOCKTAILS

All the Depth, None of the Proof—Odes to the Classics

Senza Spirito Fritz (Aperol Spritz)	16
Ritual 'Zero Proof' Aperitif, Lyre's Sparkling, Club Soda, Orange	
Free 'Margie' (Margarita)	16
Ritual 'Zero Proof' Tequila, Blue Agave, Orange, Lime	
Temperance Fashioned (Old Fashioned)	16
Ritual 'Zero Proof' Whiskey, Orange Bitters, Agave Syrup, Orange	
French Zero Zero (French 75)	16
Ritual 'Zero Proof' Gin, Lyre's Sparkling, Demerara Syrup, Lemon	

LIQUID GASTRONOMY

Modern Techniques Celebrating Culinary Creativity

	GL / BTL
Muri 'Fade to Black' Sparkling Red	18 / 72
Sparkling Cuvée of Fermented Red & Black Currants, Chamomile Kefir, Fig Leaf, Pine Needle Kvass	
Muri 'Passing Clouds' Sparkling White	18 / 72
Fermented Gooseberries, Quince, Kefir, Jasmine Tea, Woodruff, Geranium Kvass	
Muri 'Yamilé' Sparkling Rosé	17 / 68
Gooseberry, Raspberry, Smoked Rhubarb, Star Anise Pink Peppercorn, Goldenrod	

*These items contain wheat & trace amount of naturally occurring alcohol (<0.05% ABV)

BOTANICALS

Earthy, Floral & Full of Flavor

- Wild Berry & Mint Spritzer** 10
Seasonal Berries, Citrus, Spearmint, Demerara Syrup, Soda
- Passion Fruit Hibiscus Refresher** 10
Egyptian Hibiscus Infusion, Passion Fruit Nectar, Agave, Lemon
- Butterfly Pea Flower, Rose & Lemon Spritzer** 10
Organic Tea, Rose Water, Sicilian Lemon, Acacia Honey, Club Soda

ADAPTOGENICS

Nature's Remedy—Powered by Plants, Herbs & Mushrooms

- Three Spirit 'The Social'** Herbal & Restorative 16
Club Soda, Rosemary Peppercorn Bitters, Citrus
- Three Spirit 'The Livener'** Fiery & Energizing 16
Q' Grapefruit Soda, Capsicum Bitters, Candied Ginger
- Three Spirit 'The Night Cap'** Calming & Dreammaker 16
Club Soda, Smoked Rosemary, Orange Swath

FANCY FIZZ

Natural Ingredients, Organic & No Artificial Flavors or Additives

- Maine Root, Blueberry Soda** 7
Organic Sugar, Caffeine Free, Fair Trade
- Maine Root, Mandarin Orange Soda** 7
Organic Sugar, Caffeine Free, Fair Trade
- Maine Root, Root Beer** 7
Organic Sugar, Caffeine Free, Fair Trade

WINE

SPARKLING

Blanc de Blanc Weingut Leitz Sparkling Eins Zwei Zero (00% ABV) 16

WHITE

Chardonnay Leitz Eins Zwei Zero, Pfalz (00% ABV)   16

Sauvignon Blanc Weingut Leitz Sauvignon Blanc (<0.5% ABV)   16

Riesling Weingut Leitz Eins Zwei Zero Alcohol Free (00% ABV)   16

RED

Pinot Noir Weingut Leitz Baden (0.5% ABV)   16

BEER

DOMESTIC / LOCAL

Go Brewing 'Sunbeam Pils' Naperville (<0.5% ABV) 8

Go Brewing 'Freedom' West Coast Pale, Naperville (<0.5% ABV) 8

Athletic Brewing 'Free Wave' Hazy IPA, (<0.5% ABV) 8

IMPORTED

Heineken '00' Netherlands (00% ABV) 7

Peroni '00' Italy (00% ABV) 7



Vegan



Sustainable



Gluten Free



Organic



Biodynamic



DINING MENU

Bright, layered flavors, inventive preparations and dishes designed to pass, share or savor all to yourself. From craveable small plates to satisfying mains and signature exclusives, our menu plays effortlessly with our cocktail program, enhancing both flavor and mood.

"True abundance isn't excess—it's savoring what the earth gives, while keeping tomorrow on the menu."

— The Lounge Philosopher —



Vegan



Gluten Free



Vegetarian

Consuming raw or undercooked meats, poultry, seafood, shellfish, or eggs may increase your risk of foodborne illness. Please alert your server if you have any food allergies or dietary restrictions.



SNACKS

Small Bites, Big Flavor

- Parmesan & Truffle Fries** (☩) (🌱) 12
Truffle Aioli
- Signature Potato Chips** (☩) (🌱) 10
Creamy Onion Dip
- Warm Pretzel** 12
Truffle Sauce, Whole Grain Mustard, Cheese Sauce
- Crispy Brussels Sprouts** (☩) 10
Yuzu Vinaigrette, Furikake

GREENS

Fresh, Crisp & Composed

- Simple Greens Salad** (☩) (🌱) 14
Butter Lettuce, Shaved Garden Vegetables,
Goat Cheese, Lemon Dijon Vinaigrette
- BLT Salad** (🌱) 18
Iceberg Lettuce, Applewood Smoked Bacon,
Tomato, Avocado, Sherry Vinaigrette
- Baby Frisée Salad** 19
Bacon Lardon, Toasted Brioche, Roasted Walnuts,
Sherry Walnut Vinaigrette, Poached Egg

Add chicken breast +\$8 || Add grilled salmon +\$12
Add jumbo shrimp +\$14

LOUNGE SPREADS

Shareable Favorites, Elevated Classics

Hummus & Crudités 	16
Warm Pita Bread	
Half-Dozen East Coast Oysters 	24
Cocktail Sauce, Shallot Mignonette, Horseradish	
Poached Shrimp Cocktail 	26
Cocktail Sauce, Lemon	
Beef Carpaccio	24
Beef Tenderloin, Arugula, Parmesan Cheese, Capers, Garlic Aioli, Grilled Sourdough	
Wagyu Sliders	21
Ground Wagyu Beef, American Cheese, Pickle, Grilled Onion, Burger Sauce, Potato Bun	
Hot Honey Chicken Sliders	18
Fried Chicken, Hot Honey, Pickle, Coleslaw	



Vegan



Gluten Free



Vegetarian



MAINS

Bold, Well-Balanced & Satisfying

Roasted Maitake Mushroom ☼	22
Bulgur Wheat, Onion Cream, Arugula	
Charred Celery Root ☼ ☿	22
Red Quinoa, Carrot Purée, Crispy Onion	
Seared Faroe Islands Salmon ☿	29
Asparagus, Fingerling Potato, Navel Orange, Sweet Onion Relish, Tarragon Aioli	
Fish 'N Chips	27
Phyllo-cruste Sole, House Fries, Tartar Sauce	
Double Wagyu Smashburger	26
Cheddar Cheese, Lettuce, Tomato, Horseradish Aioli, Choice of House Fries or Side Salad	
ZFC	28
Fried Chicken, House Fries, Coleslaw	
Steak Frites ☿	46
Butter-basted 12oz Prime Striploin, House Fries, Shallot Herb Butter	
Gyro Sandwich	22
Roasted Lamb, Beef, Feta, Hummus, Onion, Kalamata Olive, Tomato, Lettuce, Tzatziki, Warm Pita, Choice of House Fries or Side Salad	



EXCLUSIVES







Exquisitely Crafted, High-End Dishes

Foie Gras Bites	48
Seared Hudson Valley Foie Gras, Savory Pain Perdu, Pickled Blackberry, Candied Fennel	
Caviar Tots 	95
1oz Osetra Caviar, House-Made Tots, Smoked Salmon, Crème Fraîche, Chive, Egg	
Grilled Octopus 	26
Sweet Peppers, Falafel, Kalamata Olive, Basil, Black Tomato Sauce	
Grilled Cheese & Ham	38
Grilled Manchego Curado, Ibérico Ham, Quince Paste, Marcona Almond, Arugula	
Chicken Pot Pie	48
Chicken & Truffle Roulade, Root Vegetables, Savory Pastry Crust, Crispy Chicken Skin	
Wagyu Beef Rossini 	85
6oz Wagyu Striploin, Seared Foie Gras, Crispy Potato Cake, Spinach, Black Truffle Jus	



SWEETS

Decadent, Indulgent Desserts

Classic Cheesecake 	14
Macerated Strawberry, Whipped Cream	
Vanilla Bean Crème Brûlée  	14
Shortbread Cookie, Fresh Berries	
Cinnamon Toast Crunch Cake 	14
Blueberry Compote	
Dark Chocolate Gel 	14
Devil's Food Cake, Vanilla Mousseline Raspberry	
Vanilla Ice Cream  	5



Gluten Free



Vegetarian



Zorba

LOUNGE

*"Here's to the pour that lifts the heart, lights the spark
and makes every hour a happy one."*

— The Lounge Philosopher —