

Unlocking
the potential
of water.

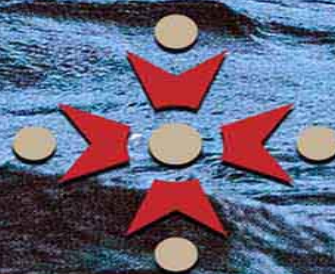

TW CONSULTING
& TRADE LTD.

Purpose.

Speed up the transition
to fossil fuel-free lakes
and oceans.



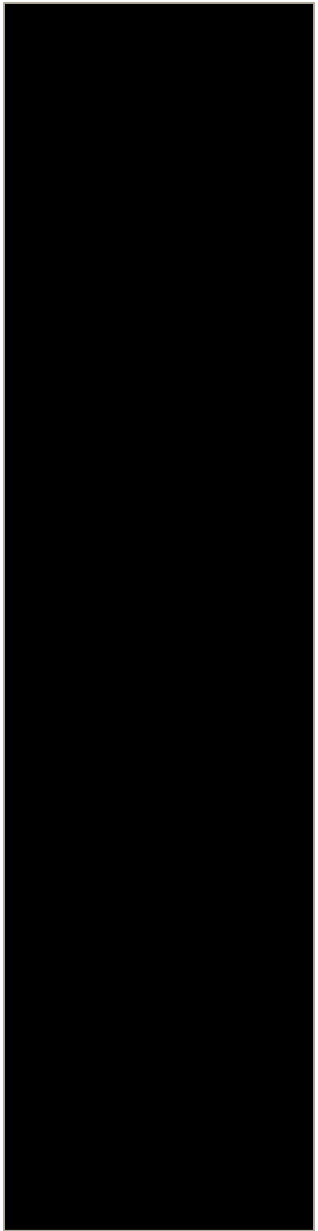

Traditional Ferry

With up to
90%
energy savings.



Candela P-12



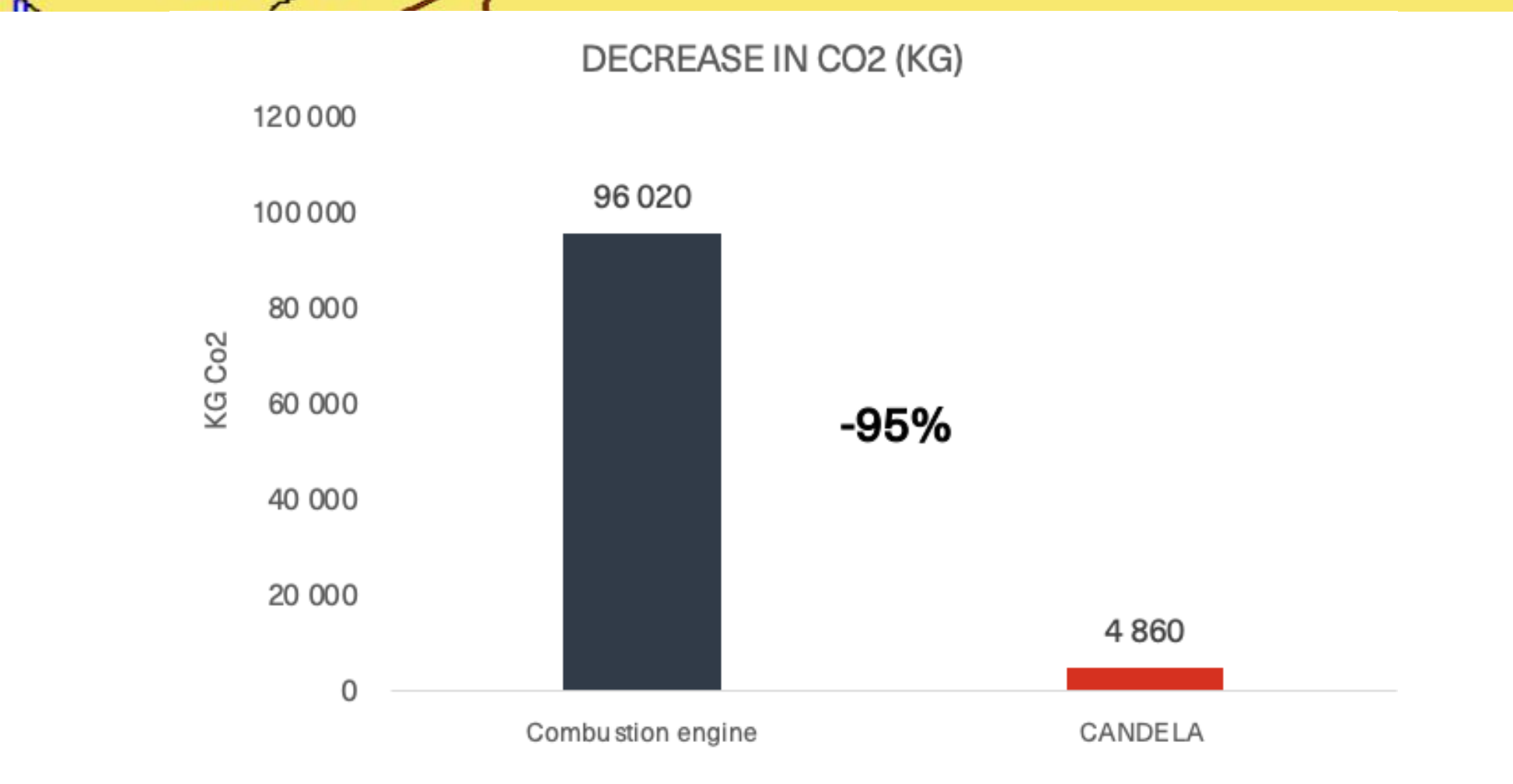
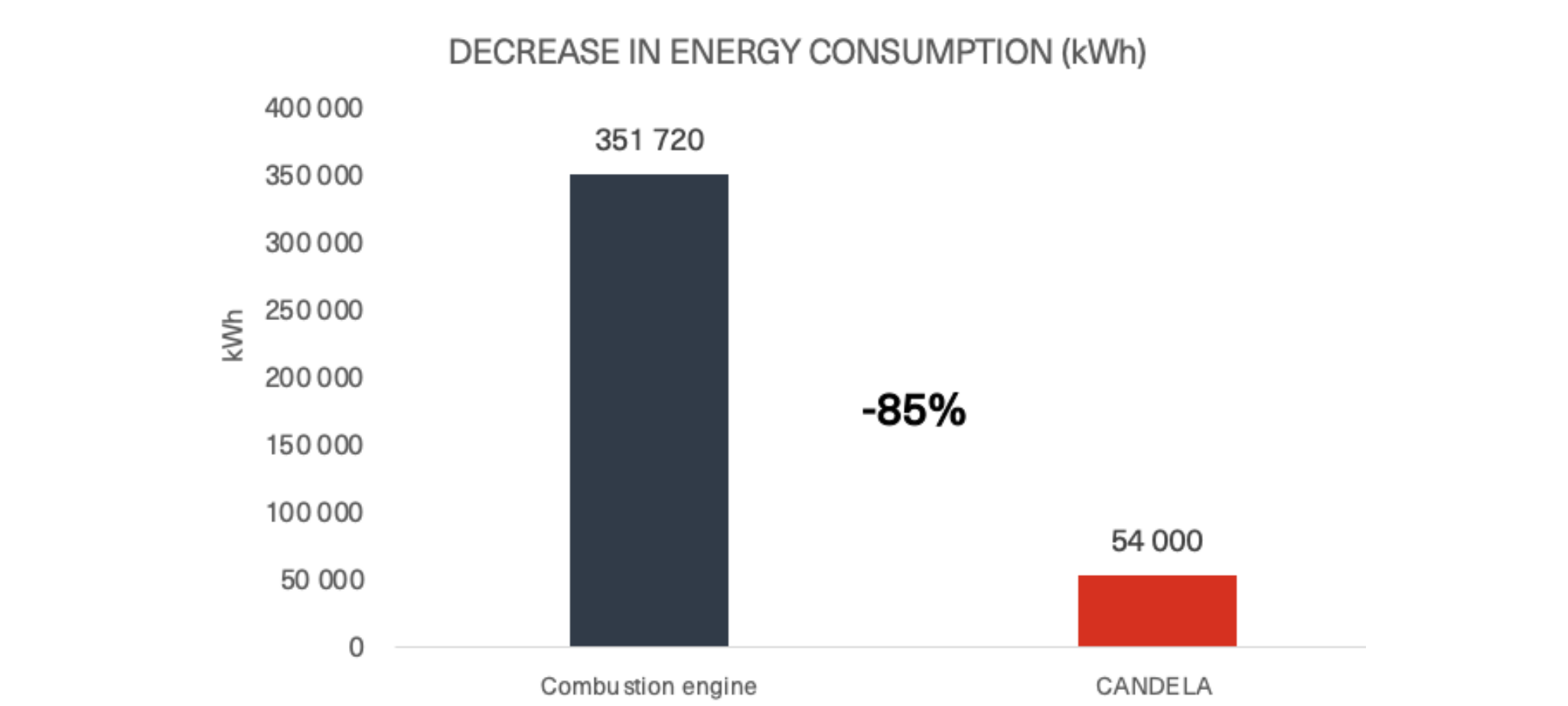
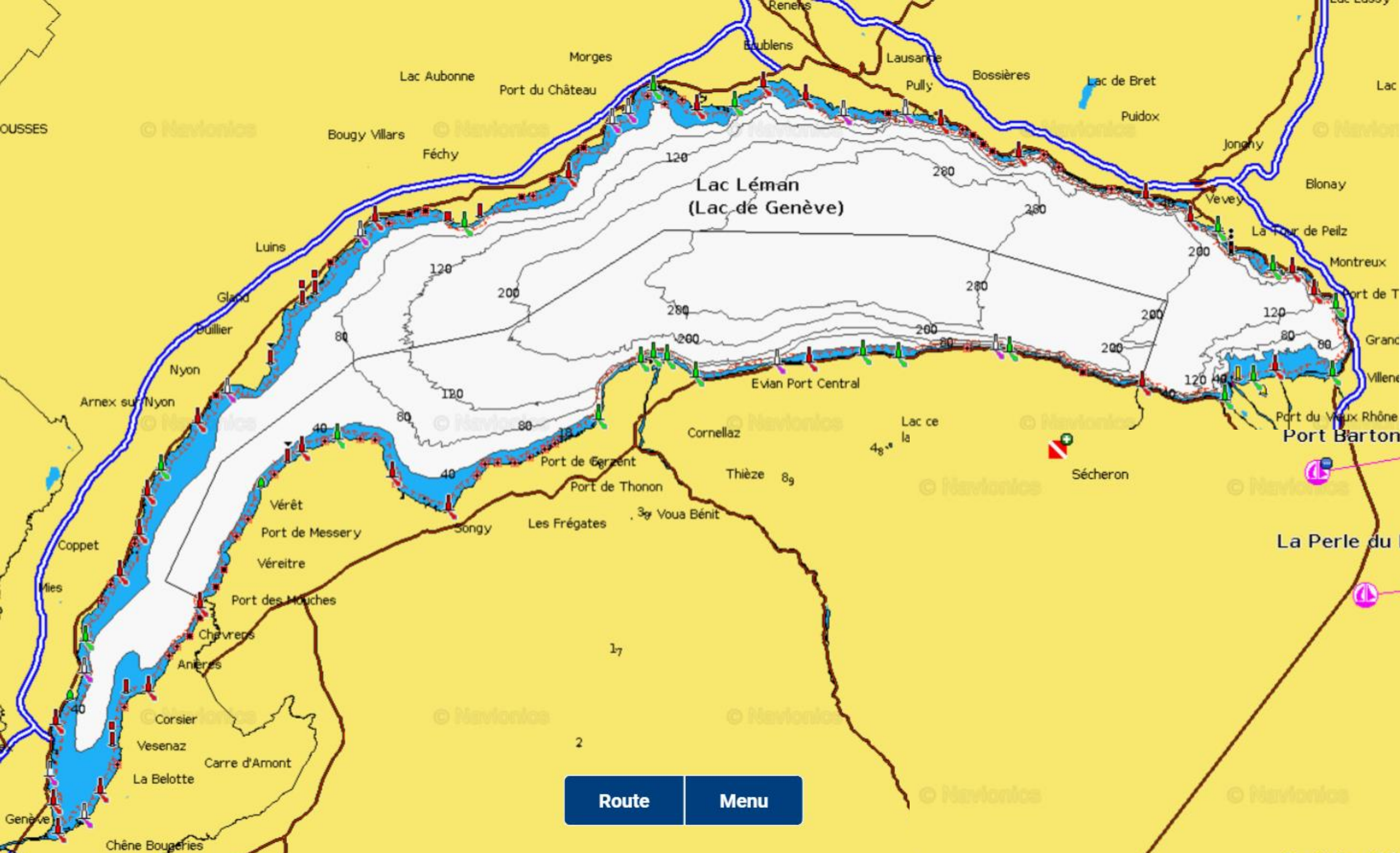

Leap-frog technology. Tried and tested.



C-7 – Serial production
32 made and sold to 10 countries



Advanced R&D and production
Launch of the C-8
Series B round



C-8 hit the water, 100+ boats sold
5 x increase of production facilities



Production and commissioning of Candela
P-12 Shuttle
220 employees



Pro-Series launched



Candela was founded with the mission to:

“Speed up the transition to fossil fuel-free lakes and oceans”

The Products.



Electric leisure boats (B2C)

First model in market	Range	Top speed	Capacity
2019	57 NM	27 kt	8 people



Pro-Series for commercial customers (B2B)

First model in market	Range	Top speed	Capacity
2024	40 NM	30 kt	Up to 30 people

Media coverage.

“A boat that completely redefines what is possible.”

—Motorboat & Yachting, August 2022

BBC

CNN

The New York Times

WIRED

MOTORBOAT
EST. 1904

Forbes

The Economist

Bloomberg

electrek

TAGESSPIEGEL

B.Z.

GOOD MORNING AMERICA

The Guardian

CORRIERE DELLA SERA

Hamburger Abendblatt

NEW ATLAS

BOAT
International

REUTERS

World's cleanest lake is getting a new flying electric hydrofoil ferry

 Micah Toll | Mar 13 2024 - 10:00 am PT |  5 Comments



New Zealand's Lake Manapōuri is often described as the cleanest lake in the world due to its crystal clear water fed by melting glaciers that carved the lake, as well as yearly snow melt. Now the lake's hydro-electric power station is getting even cleaner with the adoption of the world's first flying electric hydrofoil ferry.

FORBES > LIFESTYLE > BOATS & PLANES

What Candela's Electric Hydrofoiling Passenger Ferry Means For Sustainable Transportation

Bill Springer Senior Contributor

Bill Springer would rather be on a superyacht. And he often is.

Follow

  0

Mar 19, 2024, 05:36pm EDT









The all-electric-powered Candela P-12 ferry flies over the water on hydrofoils CANDELA

I would never say “I told you so,” but...now that [Candela](#), the world's leading producer of all-electric-powered hydrofoiling boats, has just closed the largest funding round in the company's history, I might be bold enough to say...”I'm not surprised.”

That's because I've been closely following the development of this wonderfully smart company's hydrofoiling boats since I [test flew a P-7](#) near their small and efficient shop in Stockholm in 2021. So, I'm really not surprised they just raised over \$25 million to expand production of

Global presence.



San Francisco, CA

Regional office

Stockholm, SE

Global HQ
R&D
Rotebro Factory



Bangkok, TH

Regional office



Candela offices



Candela dealers

CANDELA

100% electric hydrofoil crafts

Candela – first mover, way ahead of competitors.

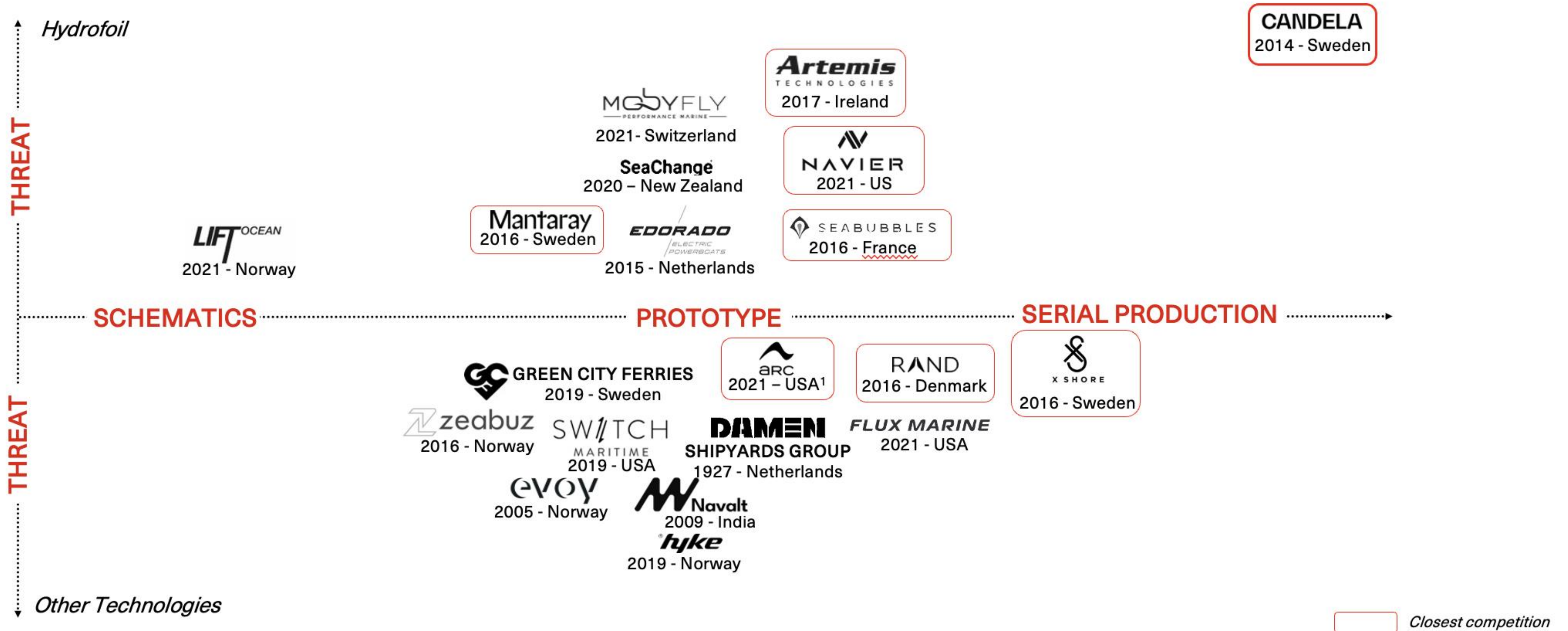

Revolutionary leaps, point by point.

ENVIRONMENT



00

Zero emissions.
Zero air, noise water
pollution.

95%

95% reduced wake - no
shoreline erosion.

95%

Up to 95% reduced
energy
consumption.

ECONOMY

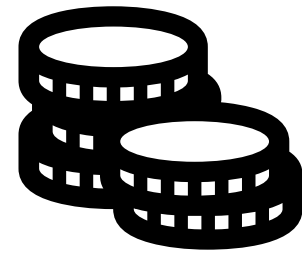

90%

Lower Energy costs

90%

Lower propulsion service
cost

Low

Big overall savings in infrastructure
investment costs.

EXPERIENCE

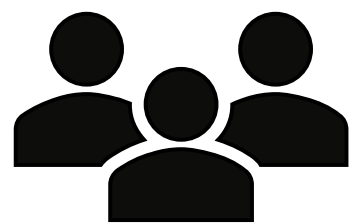

Silent

Silent flight
over choppy waters.

Fast

25 knot cruising

Smooth

No slamming

Life Cycle Assessment (P-12)

Summary of Study.

Comparison between Candela P-12 and current ferries.

The study, conducted by the Royal Institute of Technology in Stockholm, set out to determine the difference in impact of the ferries trafficking the Ekerö commuter line, operated by the City of Stockholm, and the replacement P-12 Shuttle.

The LCA takes into consideration the full impact of all materials and processes to create, use and dispose of the vessel at the end of its life cycle.

97.5%



Summary: The study concluded that over a service life of 30 years, the carbon footprint from the electric hydrofoil craft is 97.5% lower than that of the diesel vessels used to date.

Full Study click [here](#).

Impact per occupied seat GWP (Global Warming Potential)

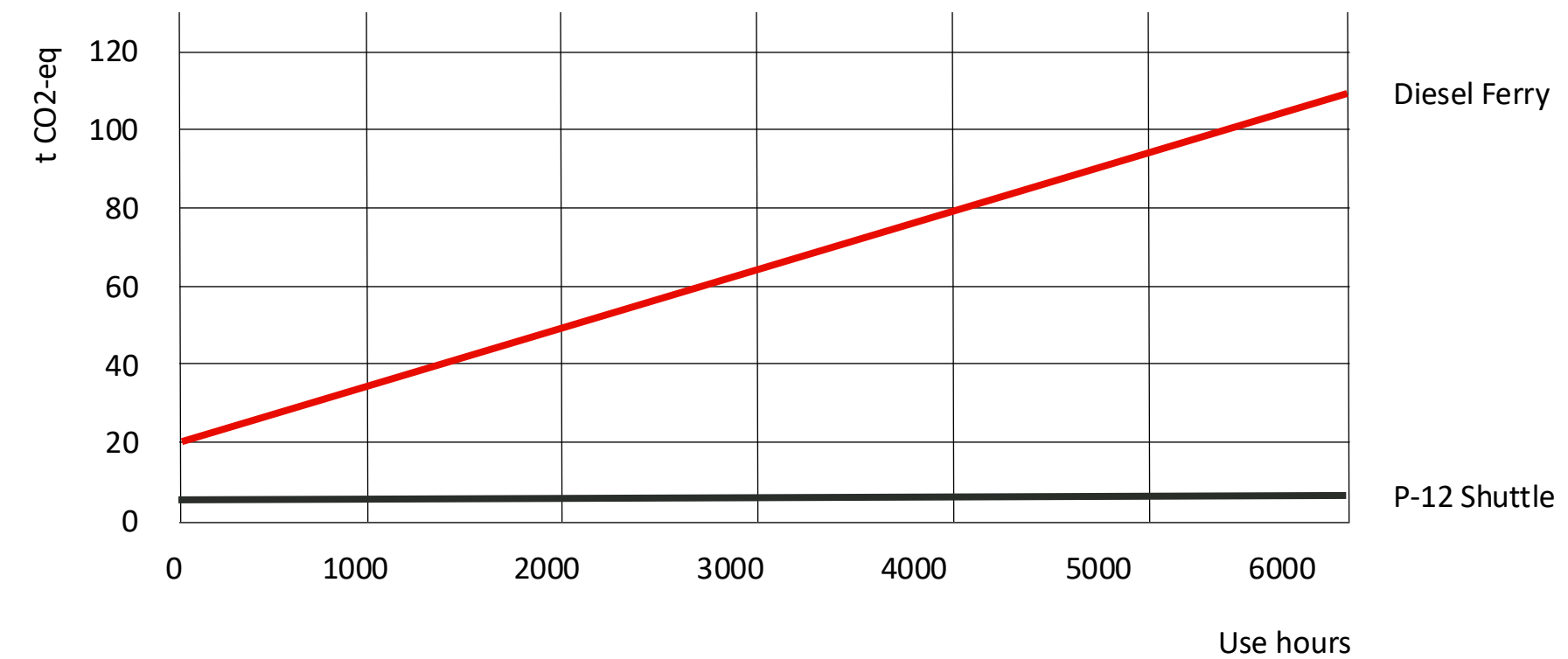

“After 4000 hours driven, the impact per occupied seat has increased by almost 60 tons CO2-equivalents for the current ferries, whereas the P-12 increased its emissions by merely 1 ton. “

Total Fleet Impact GWP (Global Warming Potential)

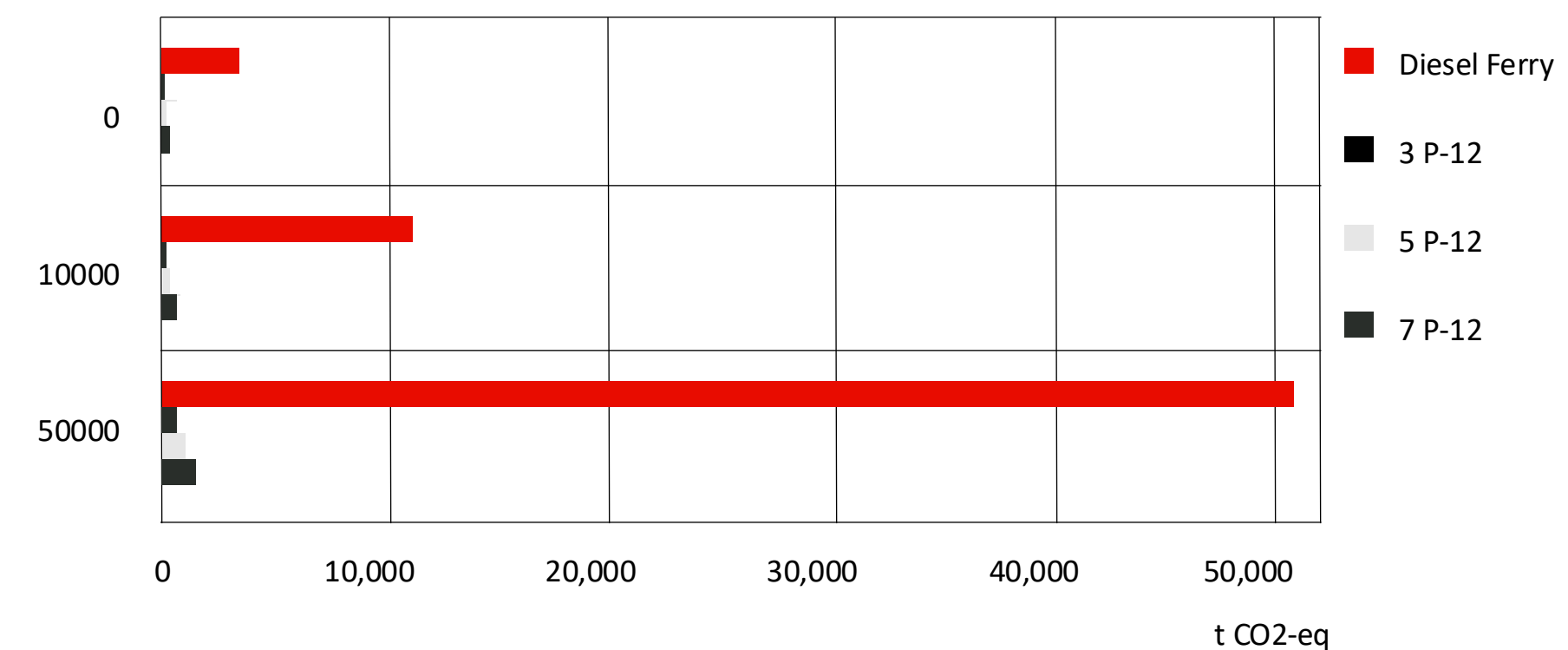

After 10 000 hours driven, the fleet impact from the current ferries is 40 times higher compared to three P-12 s, and 17 times higher than if seven P-12 s were to be used.

P-12 Shuttle (30 pax)



Versatile passenger shuttle for urban communities, new developments, holiday resorts or archipelago commuters. Toilet option available.

P-12 Business (20 pax)



Exclusive business cruiser for airport transfers, off-site meetings, conferences etc. Optional exclusive features are available to fit your needs.

P-12 Voyager (12 pax)



Premium private passenger vessel for island resorts/hotels or VIP transfers, board meetings etc. Optional exclusive features are available to fit your needs.

P-12 CTV (12-30 pax)



Crew Transfer Vessel for fast, safe and smooth transfer of crew, small cargo and other passengers and necessities.

P-12 Cargo (3.5 tons)

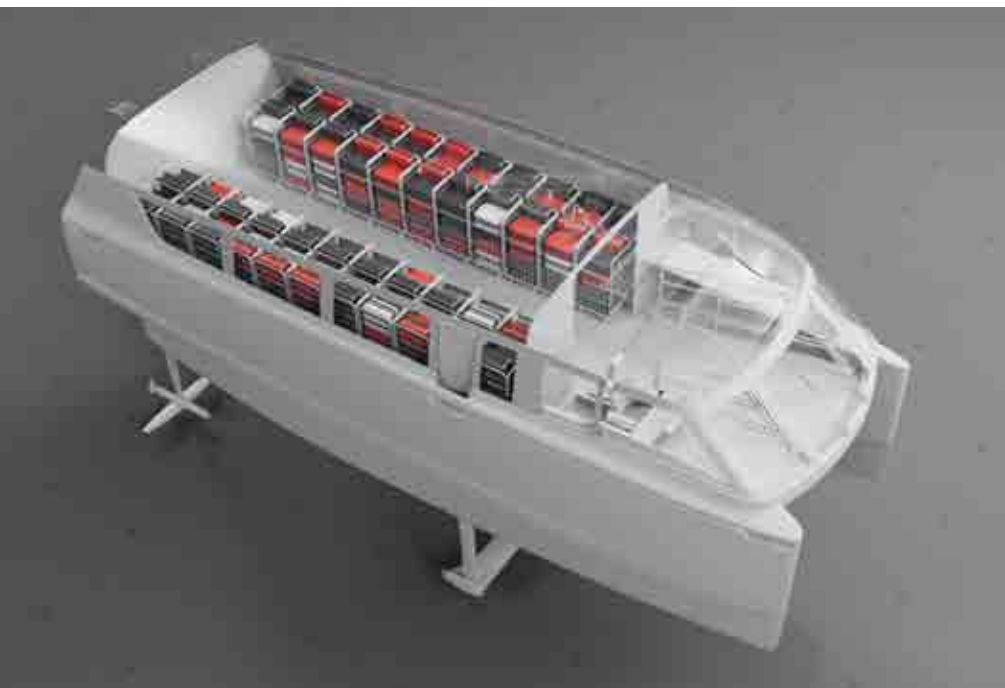

P-12 cargo can carry up to 3.000 kgs at 27 knots for fast and sustainable transport of goods in air conditioned environment if required.

P-12 Shuttle.

Specifications.

Length (m)	12
Beam (m)	4.5
Height (m)	4.3
Draft- Shallow mode (m)	1
Draft- when foiling (m)	1.2
Draft- wings down not foiling (m)	2.7
Max number of passengers	30
Max speed (knots)	27
Service speed (knots)	25
Take-off speed (knots)	20
Battery capacity (kWh)	252
DC charging (kW)	175kW
Range at service speed (Nm)	40 nm
Max payload (kg)	3,000
Certification	Type Approval DNV Craft
Significant wave height (foiling)	Hs 1 M
Significant wave height (displacement)	Hs 2 M
Wind	Beaufort 6



P-12

P-12 Shuttle
100% electric
Hydrofoil craft

30_{pax}

30 passengers
seated
comfortably

40_{nm}

Up to 40
nautical miles
range.

25_{kn}

High service speed
vessels with no
wake.

P-12 Shuttle (30 pax).



P-12 Business.

Specifications.

Length (m)	12
Beam (m)	4.5
Height (m)	4.3
Draft- Shallow mode (m)	1
Draft- when foiling (m)	1.2
Draft- wings down not foiling (m)	2.7
Max number of passengers	30
Max speed (knots)	27
Service speed (knots)	25
Take-off speed (knots)	20
Battery capacity (kWh)	252
AC charging	400Vx3x16A
DC charging (kW)	175kW
Range at service speed (Nm)	40 nm
Max payload (kg)	2,000
Certification	Type Approval DNV Craft
Significant wave height (foiling)	Hs 1 M
Significant wave height (displacement)	Hs 2 M
Wind	Beaufort 6



P-12

P-12 Business
100% electric
Hydrofoil craft

20_{pax}

20 passengers
seated
comfortably

40_{nm}

Up to 40
nautical miles
range.

25_{kn}

High service speed
vessels with no
wake.

P-12 Business (20 pax).



P-12 Voyager.

Specifications.

Length (m)	12
Beam (m)	4.5
Height (m)	4.3
Draft- Shallow mode (m)	1
Draft- when foiling (m)	1.2
Draft- wings down not foiling (m)	2.7
Max number of passengers	30
Max speed (knots)	27
Service speed (knots)	25
Take-off speed (knots)	20
Battery capacity (kWh)	252
AC charging	400Vx3x16A
DC charging (kW)	175kW
Range at service speed (Nm)	40 nm
Max payload (kg)	1,200
Certification	Type Approval DNV Craft
Significant wave height (foiling)	Hs 1 M
Significant wave height (displacement)	Hs 2 M
Wind	Beaufort 6



P-12

P-12 Voyager
100% electric
Hydrofoil craft

12_{pax}

12 passengers
seated
comfortably

40_{nm}

Up to 40
nautical miles
range.

25_{kn}

High service speed
vessels with no
wake.

P-12 Voyager (12 pax).



Smart

Water

Mobility by CANDELA

Fleet Systems

Earth's greatest infrastructure.

Water is flexible and it's maintenance-free.

Today's water mobility is neither cost-efficient nor environmentally sound.

It's over-polluted and under-utilised.

We have the opportunity to unlock water's **full potential.**





Think fleet, not vessel. Candela Fleet Systems.

Traditional Operations.

Few large vessels. 100-200pax.

Slow
Inefficient - Expensive
Often overcapacity
Large investments to scale
Inflexible
Huge emissions

Candela Fleets.

Multiple, fast and nimble. 30pax.

Same # of passengers transported
Increased speed
More frequent departures
Flexibility to shift capacity
Increased utilization
Significantly reduced OPEX
Zero Emission

Total CO₂ emissions vs emissions per passenger /kilometer.

Total emissions (million t CO₂e)

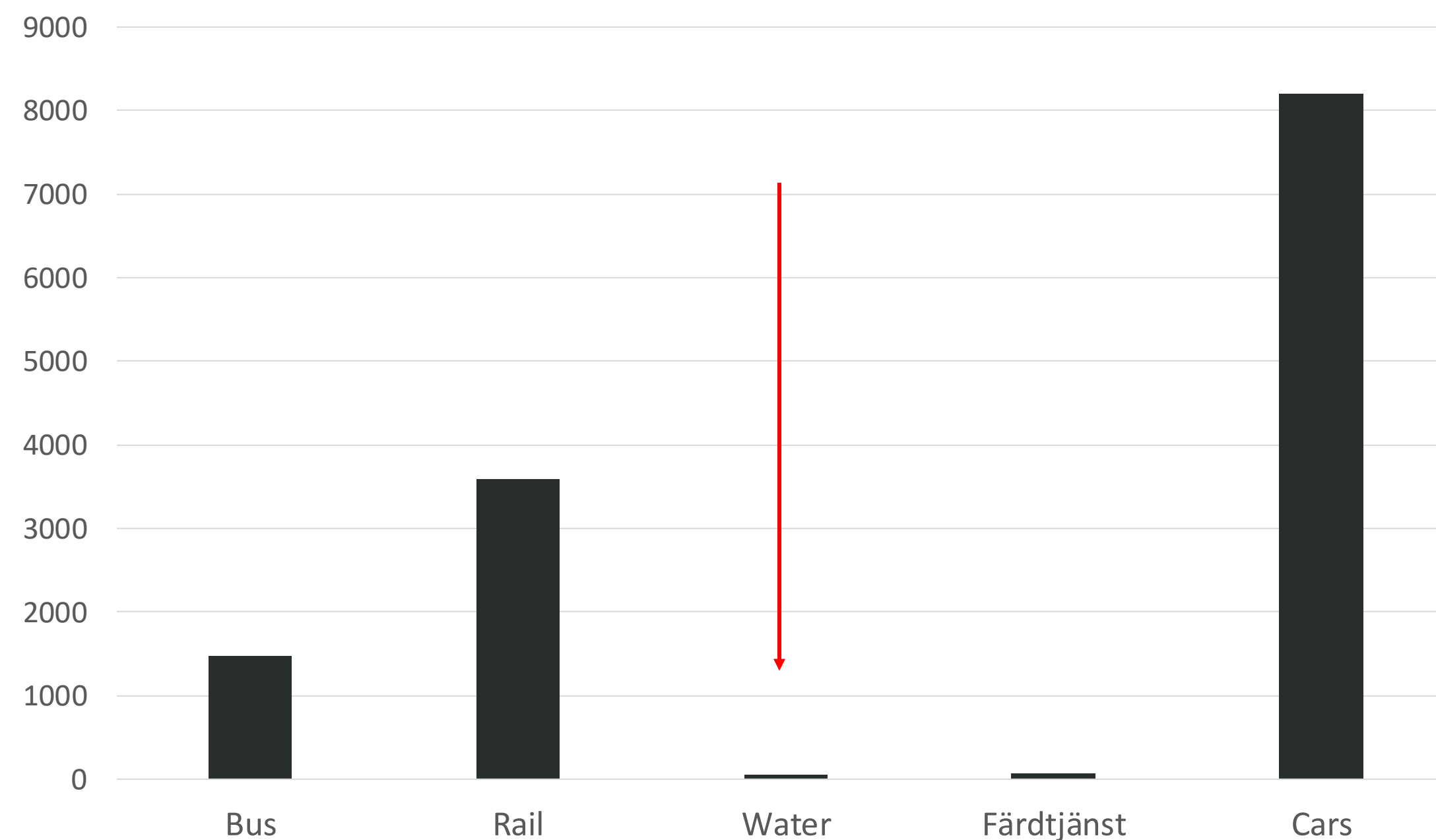

Emissions g/pkm

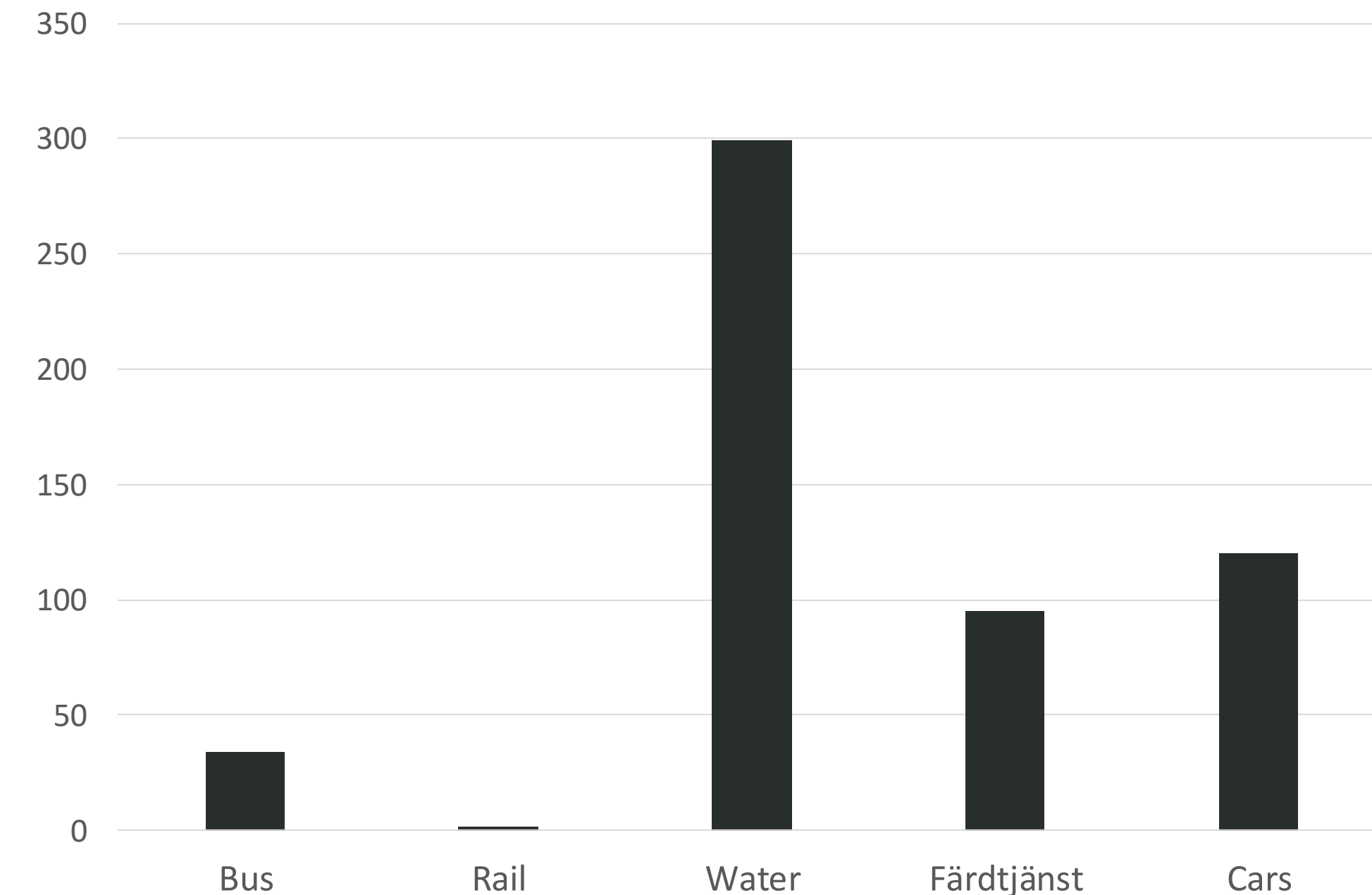

Source: Region Stockholm, Sustainability Report 2023

The Stockholm project.

Proving the case.

In cooperation with:

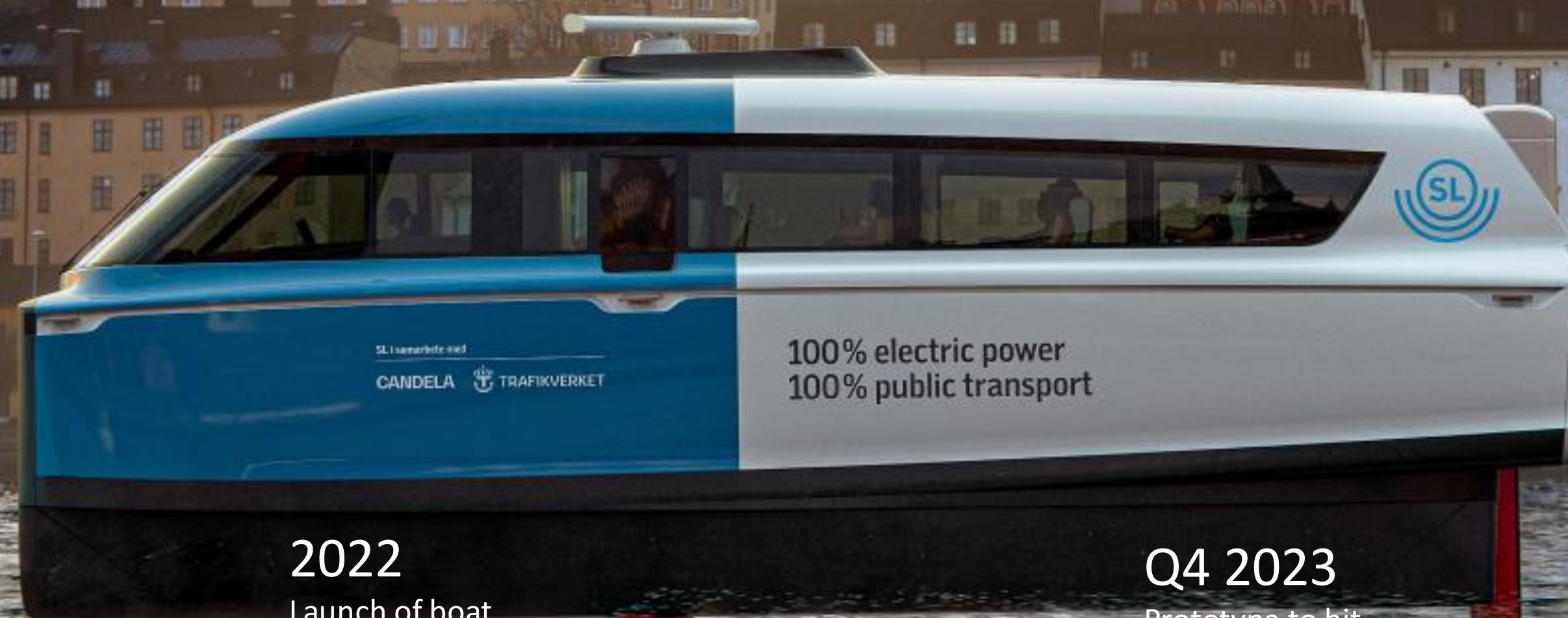

2021
Project start

2022
Launch of boat

Q4 2023
Prototype to hit
water

Q4 2024
In traffic

Extensive testing by Candela



THE STOCKHOLM CASE.

3 x Candela P-12 Shuttle = 2 x Current vessels (200 pax ea)

Passenger capacity increase

+15%

Operating costs decreased with

-60%

Energy consumption down by

-95%

Travel time reduced with

-50%

Zero-emission

0

(+ More frequent departures with reduced waiting time.)



CANDELA

Immediate benefits

With massive scalability.

Scalability case

Existing vs Candela P-12 Shuttle

3 x Candela P-12 vessels:

Passenger increase:		+15%
Investment cost:	-50%	
Operational cost:		-60%

8 x Candela P-12 vessels:

Passenger increase:	+ 35%	+ 210%
Investment cost:		
Operational cost:		+ -0%

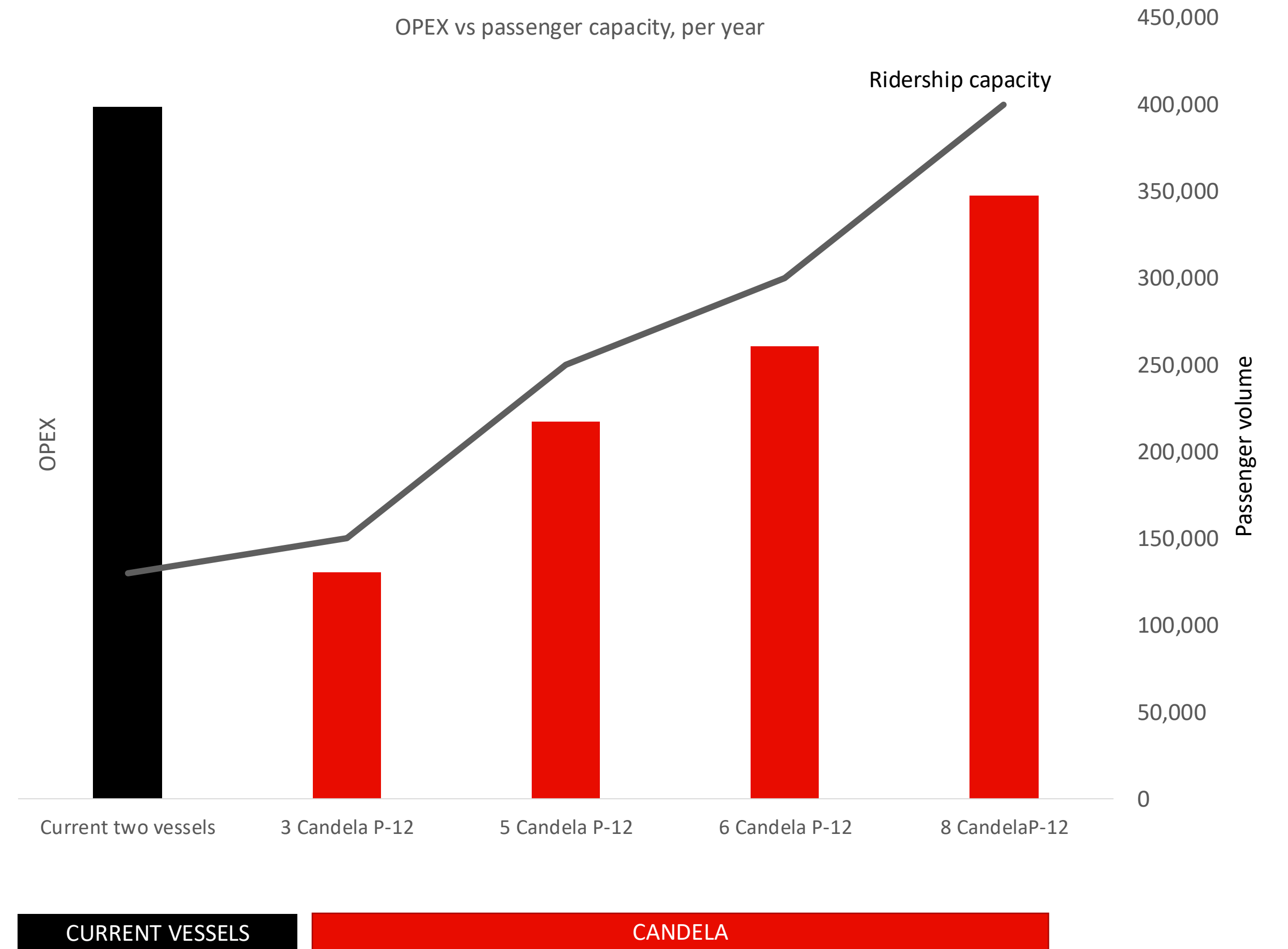

Scenario analysis of potential service demand on Route 89.

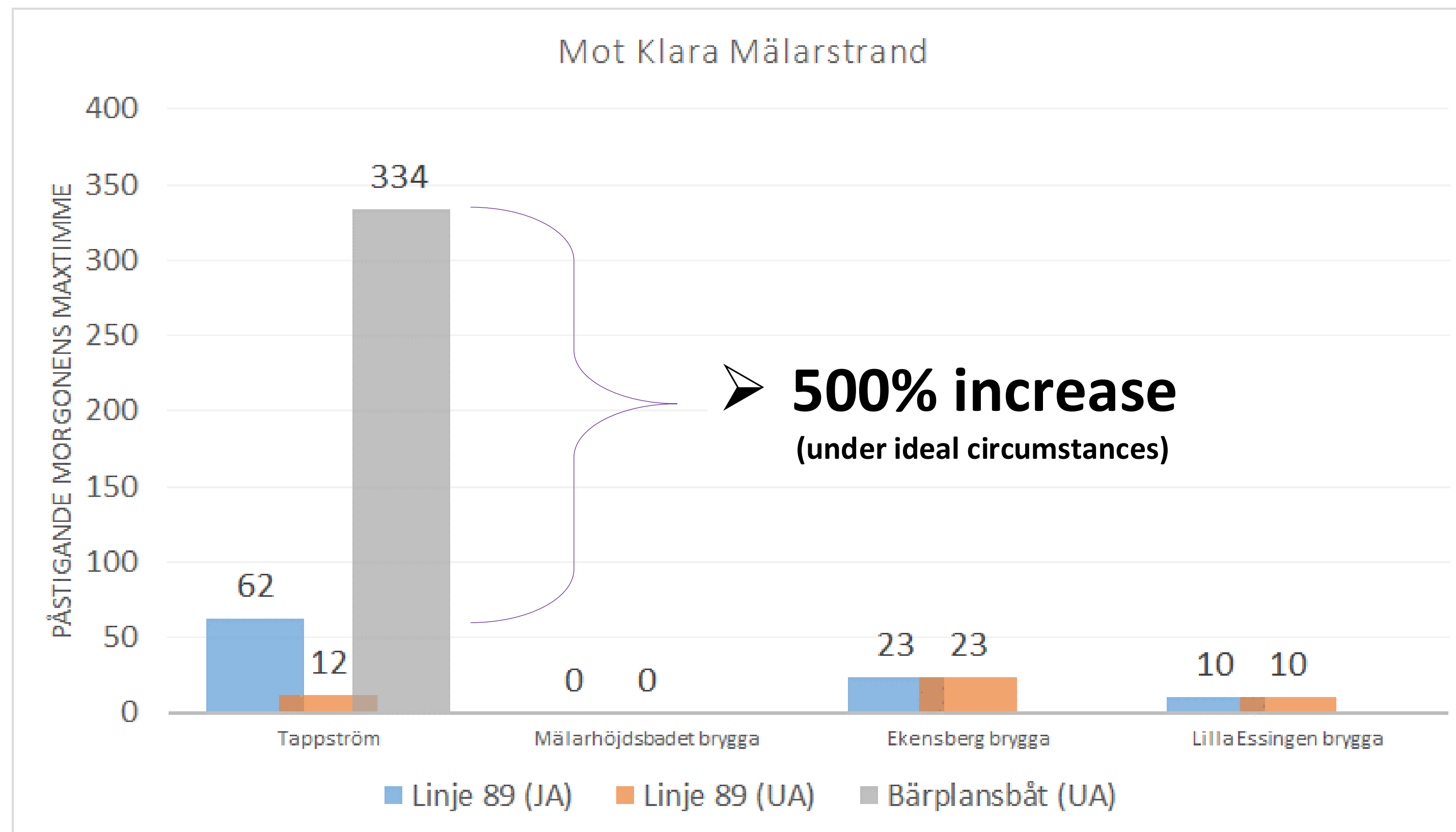

Source: Region Stockholm

8 Boats – suggested time table, including charging stops, operating hours between 05:00 and 24:00

City Center

Suburb

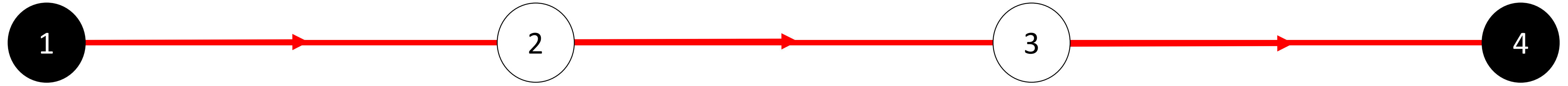

05:00	11:20	17:21	05:11	11:31	17:32	05:17	11:37	17:38	05:20	11:40	17:41
05:08	11:25	17:30	05:19	11:36	17:41	05:25	11:42	17:47	05:28	11:45	17:50
05:16	11:28	18:00	05:27	11:39	18:11	05:33	11:45	18:17	05:36	11:48	18:20
05:20	11:36	18:08	05:31	11:47	18:19	05:37	11:53	18:25	05:40	11:56	18:28
05:25	11:45	18:16	05:36	11:56	18:27	05:42	12:02	18:33	05:45	12:05	18:36
05:28	12:00	18:20	05:39	12:11	18:31	05:45	12:17	18:37	05:48	12:20	18:40
05:36	12:08	18:25	05:47	12:19	18:36	05:53	12:25	18:42	05:56	12:28	18:45
05:45	12:16	18:28	05:56	12:27	18:39	06:02	12:33	18:45	06:05	12:36	18:48
06:15	12:20	18:36	06:26	12:31	18:47	06:32	12:37	18:53	06:35	12:40	18:56
06:23	12:25	18:45	06:34	12:36	18:56	06:40	12:42	19:02	06:43	12:45	19:05
06:31	12:28	19:00	06:42	12:39	19:11	06:48	12:45	19:17	06:51	12:48	19:20
06:35	12:36	19:08	06:46	12:47	19:19	06:52	12:53	19:25	06:55	12:56	19:28
06:40	12:45	19:16	06:51	12:56	19:27	06:57	13:02	19:33	07:00	13:05	19:36
06:43	13:00	19:20	06:54	13:11	19:31	07:00	13:17	19:37	07:03	13:20	19:40
06:51	13:08	19:25	07:02	13:19	19:36	07:08	13:25	19:42	07:11	13:28	19:45
07:00	13:16	19:28	07:11	13:27	19:39	07:17	13:33	19:45	07:20	13:36	19:48
07:15	13:20	19:36	07:26	13:31	19:47	07:32	13:37	19:53	07:35	13:40	19:56
07:23	13:25	19:45	07:34	13:36	19:56	07:40	13:42	20:02	07:43	13:45	20:05
07:31	13:28	20:15	07:42	13:39	20:26	07:48	13:45	20:32	07:51	13:48	20:35
07:35	13:36	20:23	07:46	13:47	20:34	07:52	13:53	20:40	07:55	13:56	20:43
07:40	13:45	20:31	07:51	13:56	20:42	07:57	14:02	20:48	08:00	14:05	20:51
07:43	14:30	20:35	07:54	14:41	20:46	08:00	14:47	20:52	08:03	14:50	20:55
07:51	14:38	20:40	08:02	14:49	20:51	08:08	14:55	20:57	08:11	14:58	21:00
08:00	14:46	20:43	08:11	14:57	20:54	08:17	15:03	21:00	08:20	15:06	21:03
08:15	14:50	20:51	08:26	15:01	21:02	08:32	15:07	21:08	08:35	15:10	21:11
08:23	14:55	21:00	08:34	15:06	21:11	08:40	15:12	21:17	08:43	15:15	21:20
08:31	14:58	21:30	08:42	15:09	21:41	08:48	15:15	21:47	08:51	15:18	21:50
08:35	15:06	21:38	08:46	15:17	21:49	08:52	15:23	21:55	08:55	15:26	21:58
08:40	15:15	21:46	08:51	15:26	21:57	08:57	15:32	22:03	09:00	15:35	22:06
08:43	15:45	21:50	08:54	15:56	22:01	09:00	16:02	22:07	09:03	16:05	22:10
08:51	15:53	21:55	09:02	16:04	22:06	09:08	16:10	22:12	09:11	16:13	22:15
09:00	16:01	21:58	09:11	16:12	22:09	09:17	16:18	22:15	09:20	16:21	22:18
09:30	16:05	22:06	09:41	16:16	22:17	09:47	16:22	22:23	09:50	16:25	22:26
09:38	16:10	22:15	09:49	16:21	22:26	09:55	16:27	22:32	09:58	16:30	22:35
09:46	16:13	22:45	09:57	16:24	22:56	10:03	16:30	23:02	10:06	16:33	23:05
09:50	16:21	22:53	09:57	16:24	22:56	10:07	16:38	23:10	10:10	16:41	23:13
09:55	16:30	23:01	10:01	16:32	23:04	10:12	16:47	23:18	10:15	16:50	23:21
09:58	16:45	23:05	10:06	16:41	23:12	10:15	17:02	23:22	10:18	17:05	23:25
10:06	16:53	23:10	10:09	16:56	23:16	10:23	17:10	23:27	10:26	17:13	23:30
10:15	17:01	23:13	10:17	17:04	23:21	10:32	17:18	23:30	10:35	17:21	23:33
11:00	17:05	23:21	10:26	17:12	23:24	11:17	17:22	23:38	11:20	17:25	23:41
11:08	17:10	23:30	11:11	17:16	23:32	11:25	17:27	23:47	11:28	17:30	23:50
11:16	17:13		11:19	17:21	23:41	11:33	17:30		11:36	17:33	
			11:27	17:24							

Economy.

Fast and sustainable at a minimal cost.
Example route calculations

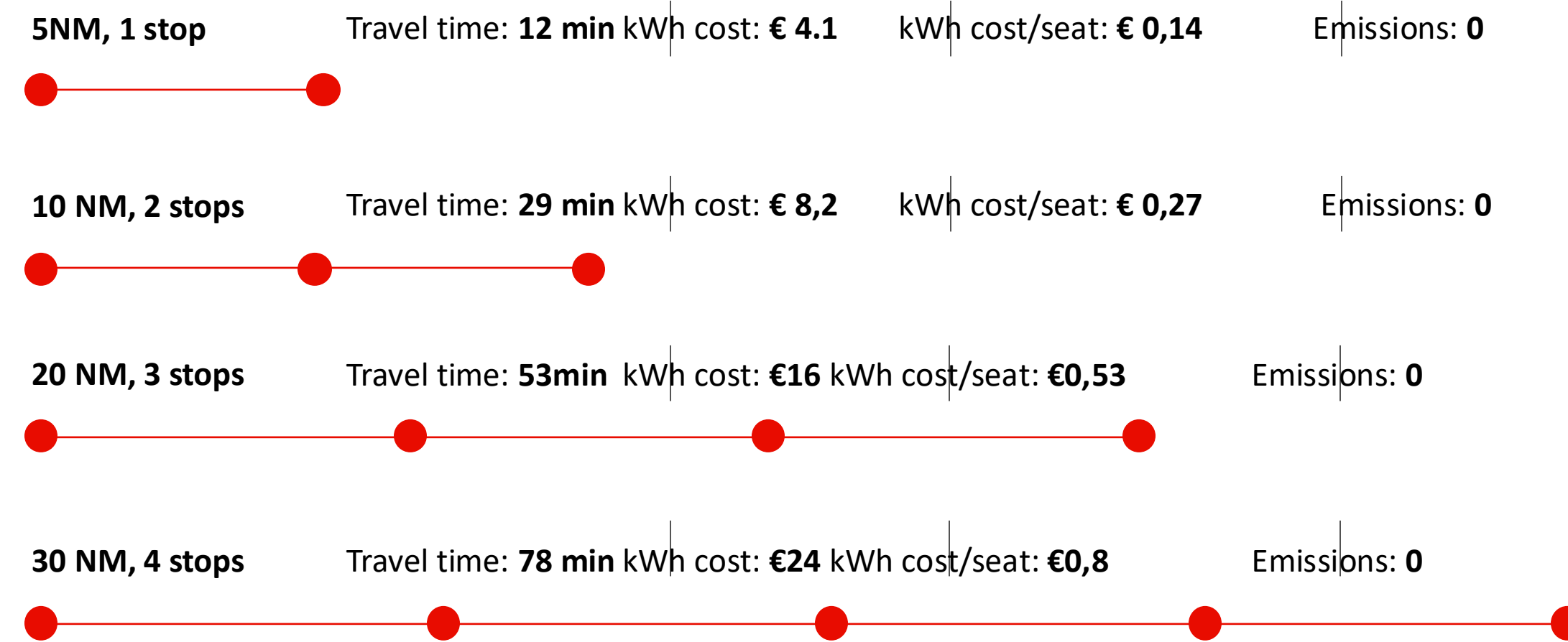

kWh = €0,1. Travel time includes 2 min turnaround per stop

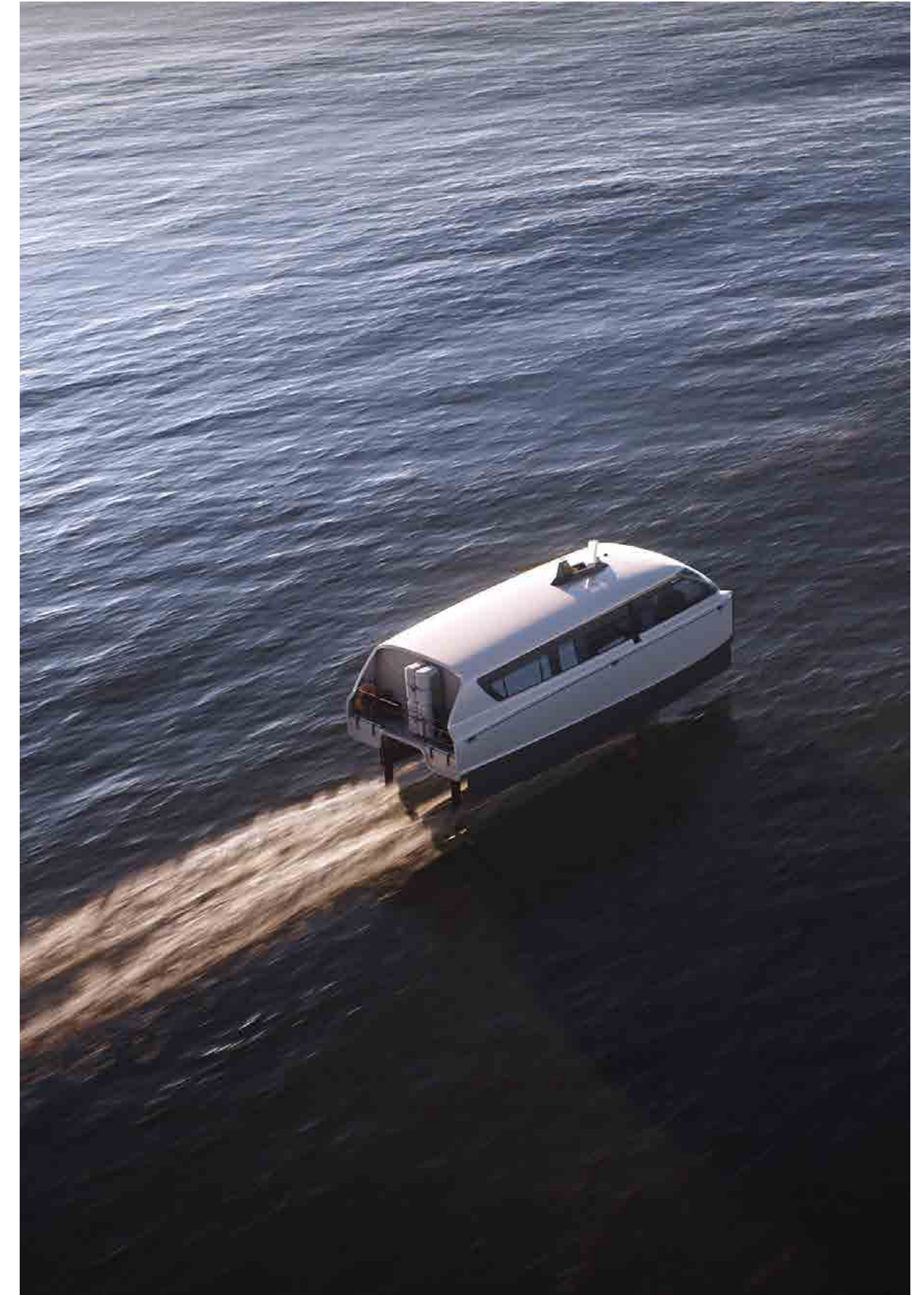

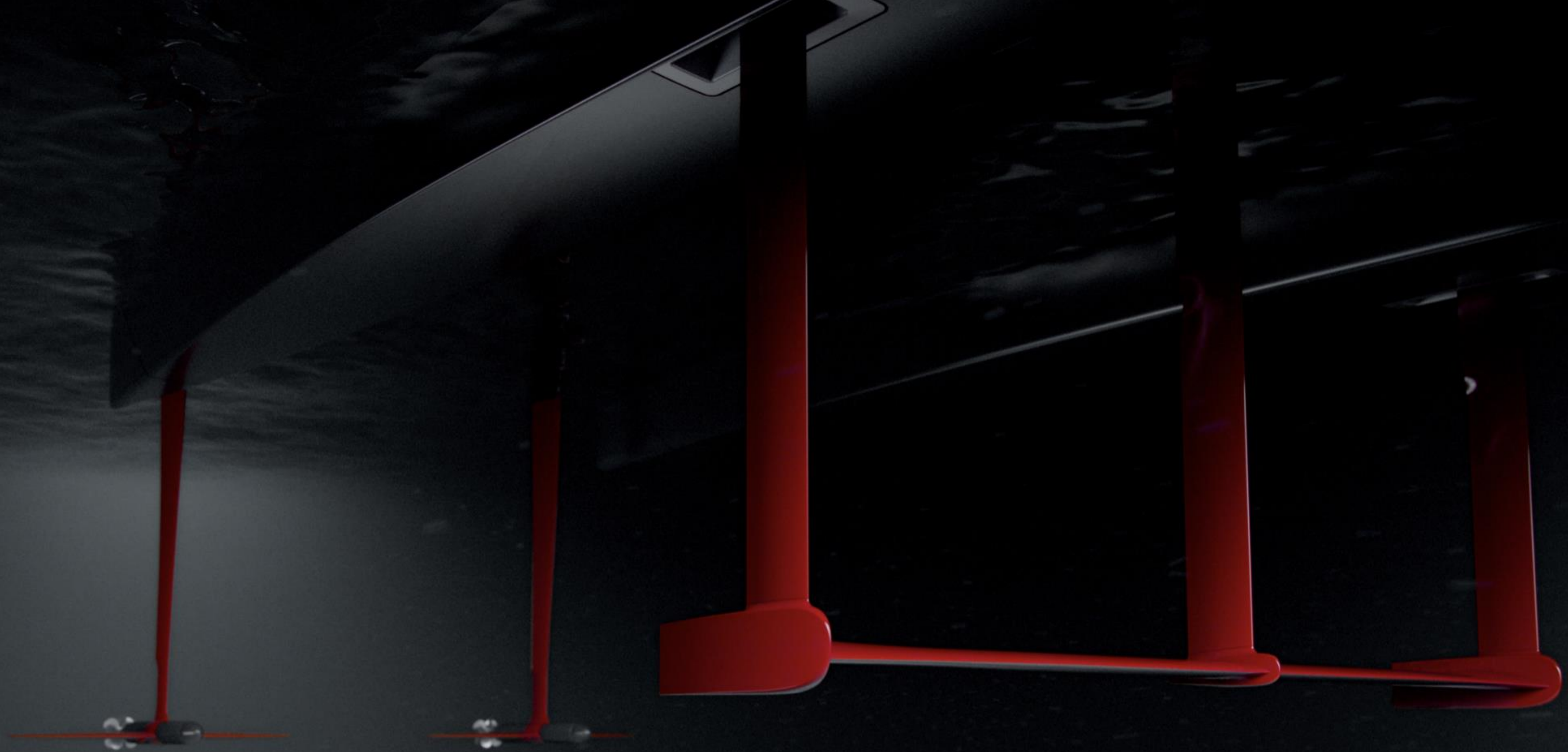

Electric Pod Motor

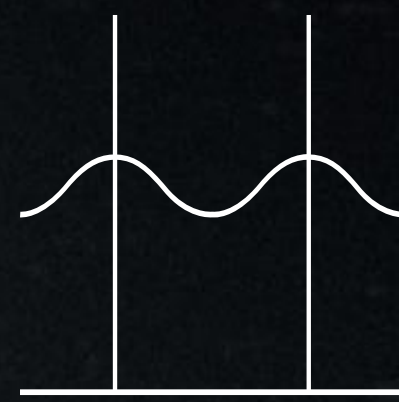

Hydrofoil Technology

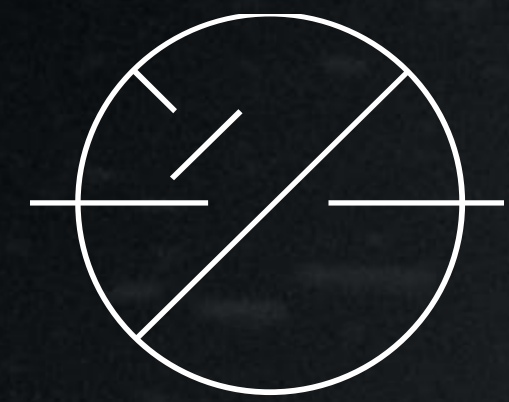

Flight Control System

Core Tech Trinity



Hydrofoil Technology (Candela C-FOIL)

Hydrofoils remove 80% of the drag compared to a planing boat. This is the most important principle in our design.

The C-FOIL System fitted in Candela hydrofoil craft is made entirely from carbon composites and uses design principles from the aviation industry.

Just like an airplane wing, it creates an upward lift, enabling the craft to take off.



Electric Pod Motor (Candela C-POD)

The Candela C-POD is the most efficient and long-lasting boat motor ever made. Two ultra-compact magnet motors, fully submerged, provide enough thrust to make our boats fly at a speed of 30 knots, in absolute silence.

Electric direct-drive means no noise from gears, no oil changes and little maintenance.

The patent-pending Candela C-POD will last a lifetime, with little service needs.

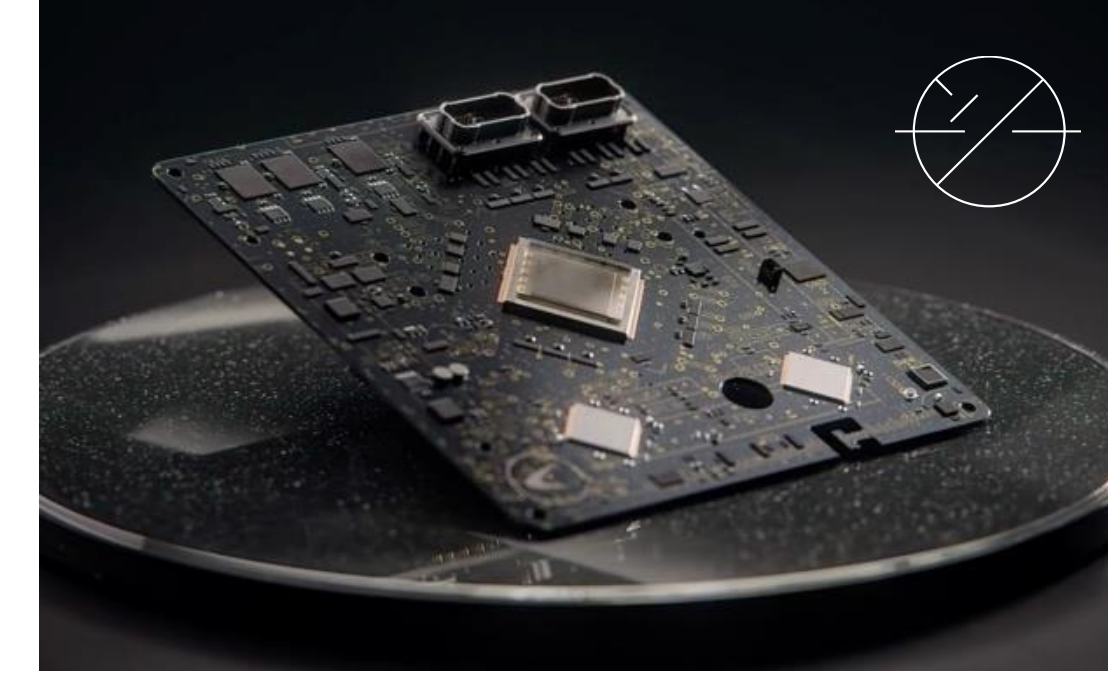

Flight Control System (Candela C-FLHT)

A flying boat with submerged foils needs active stabilization. It's the component that brings it all together and makes the craft easy and safe to manoeuvre.

Our industry-leading software and electronics employ a variety of sensors around the craft to estimate the position, velocity, and acceleration of the boat. Using that data to design a smooth and pleasant experience, even in rough seas or sharp turns.



Key exterior dimensions

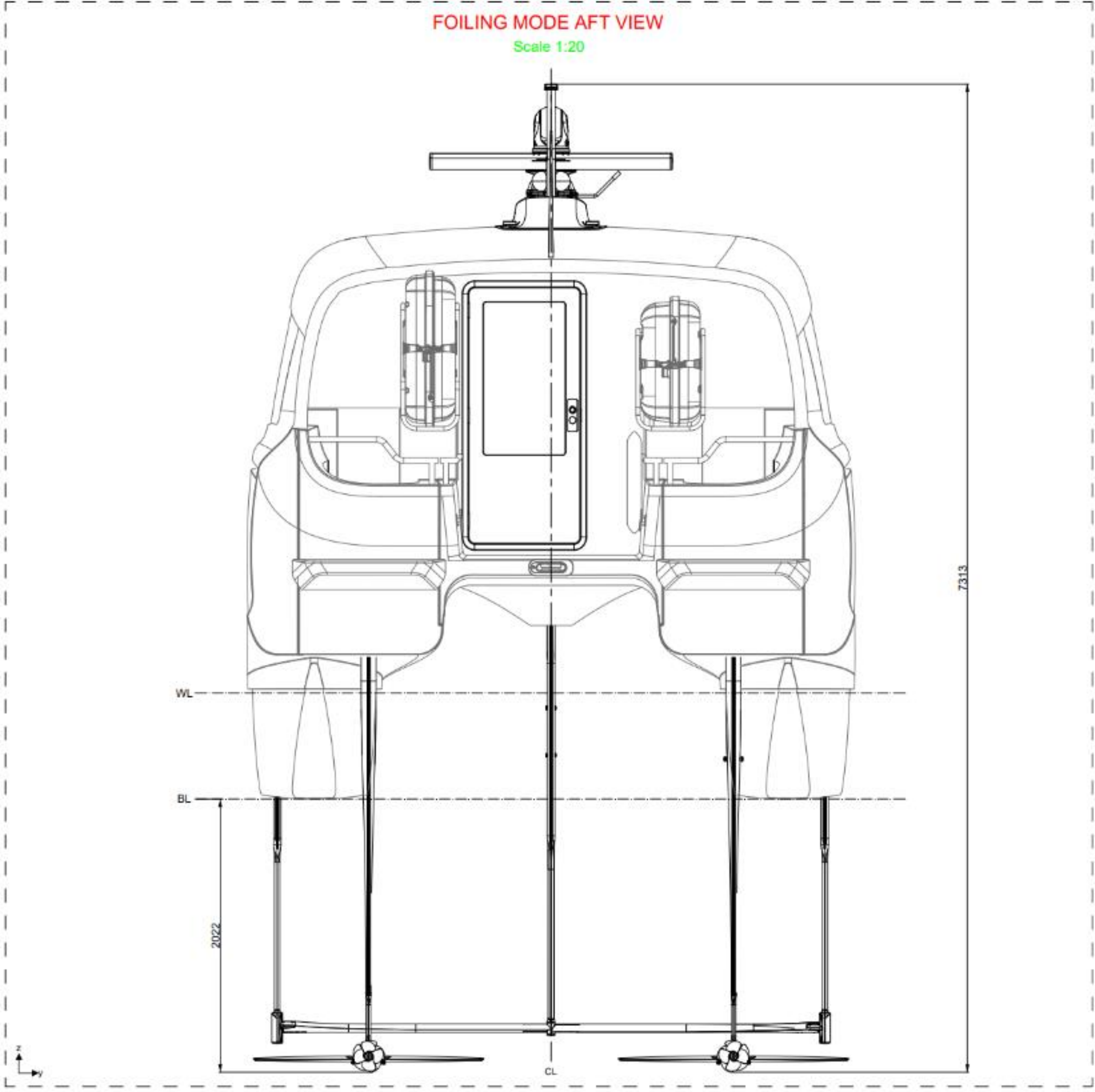
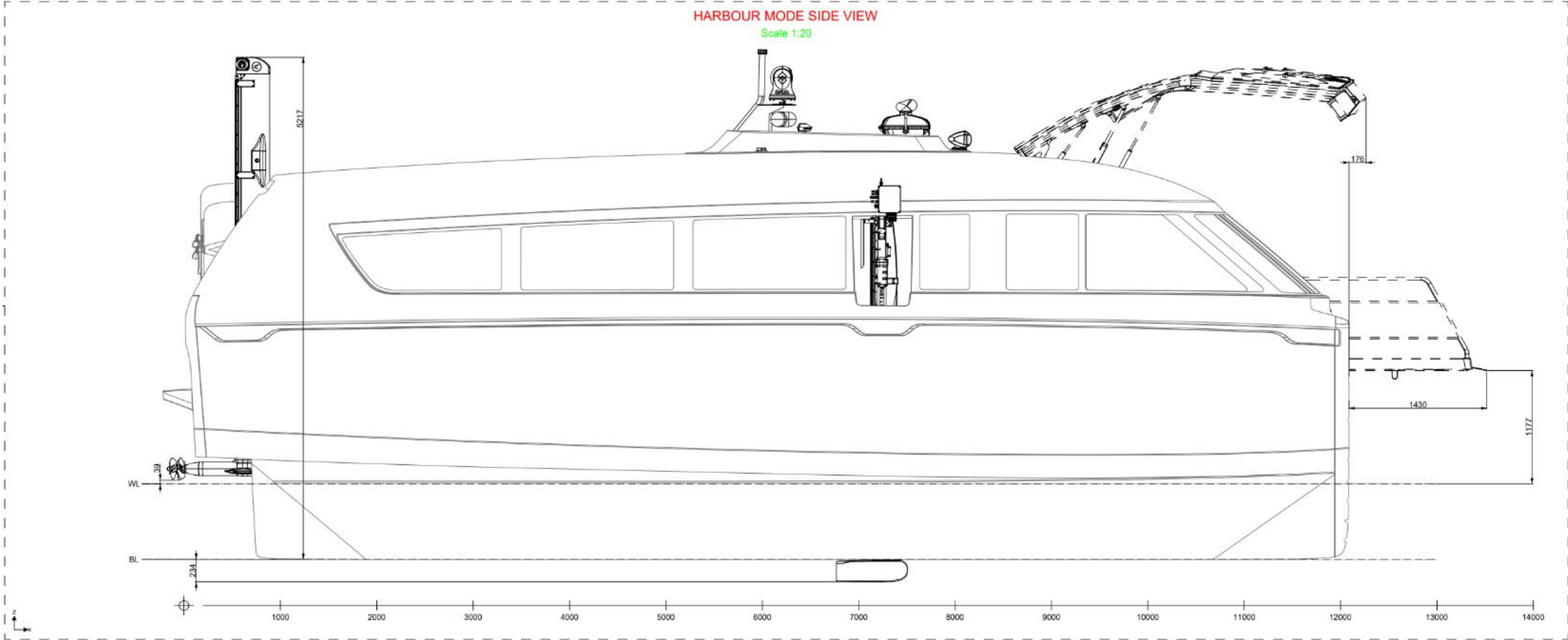
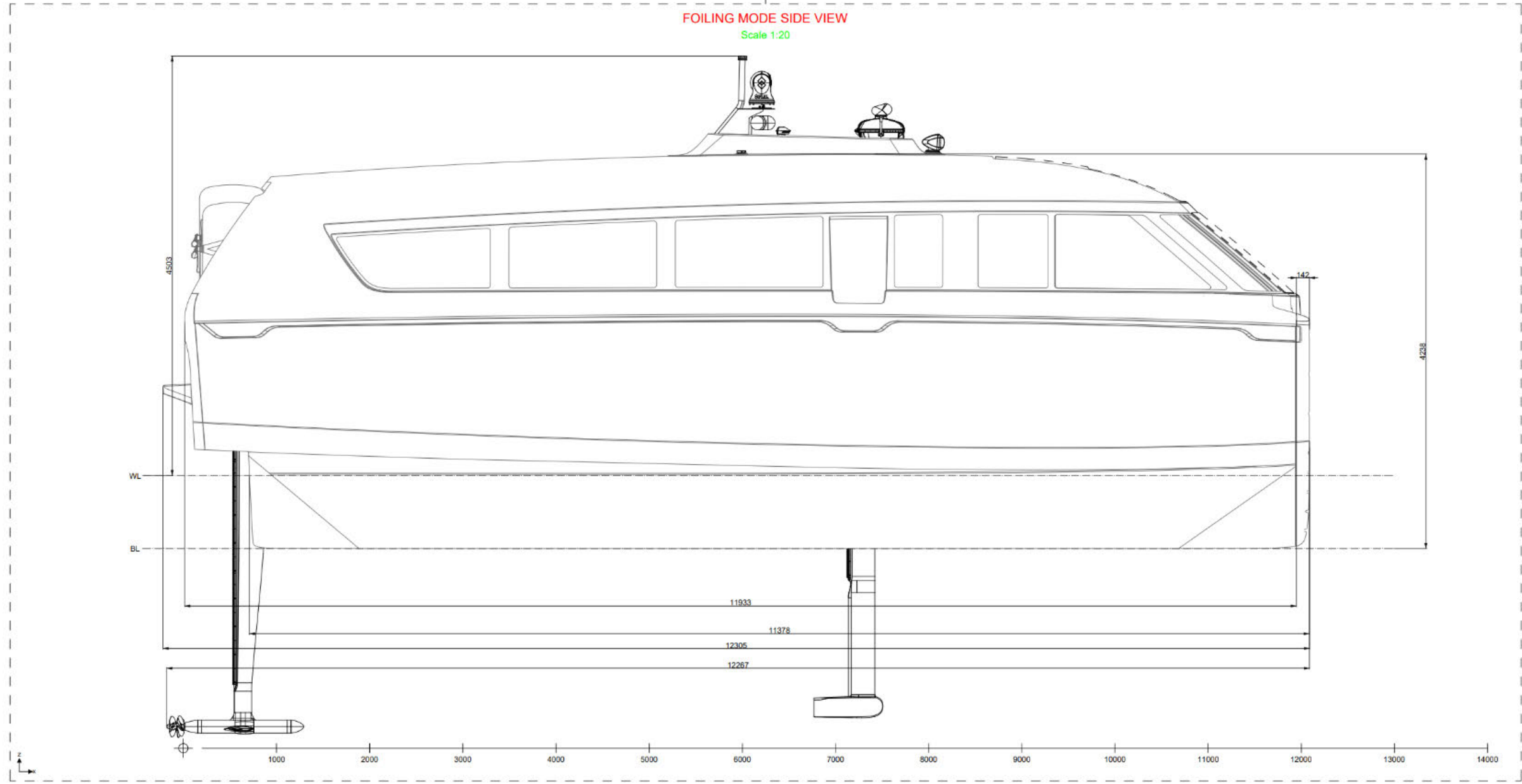

Draft dimensions

Air draft from waterline (displacement)	4.5 m
Air draft from waterline (when foiling)	5.8 m
Draft in shallow mode	1.2 m
Draft with foils extended - Displacement	2.7 m
Draft with foils extended - Foiling	1.5 m

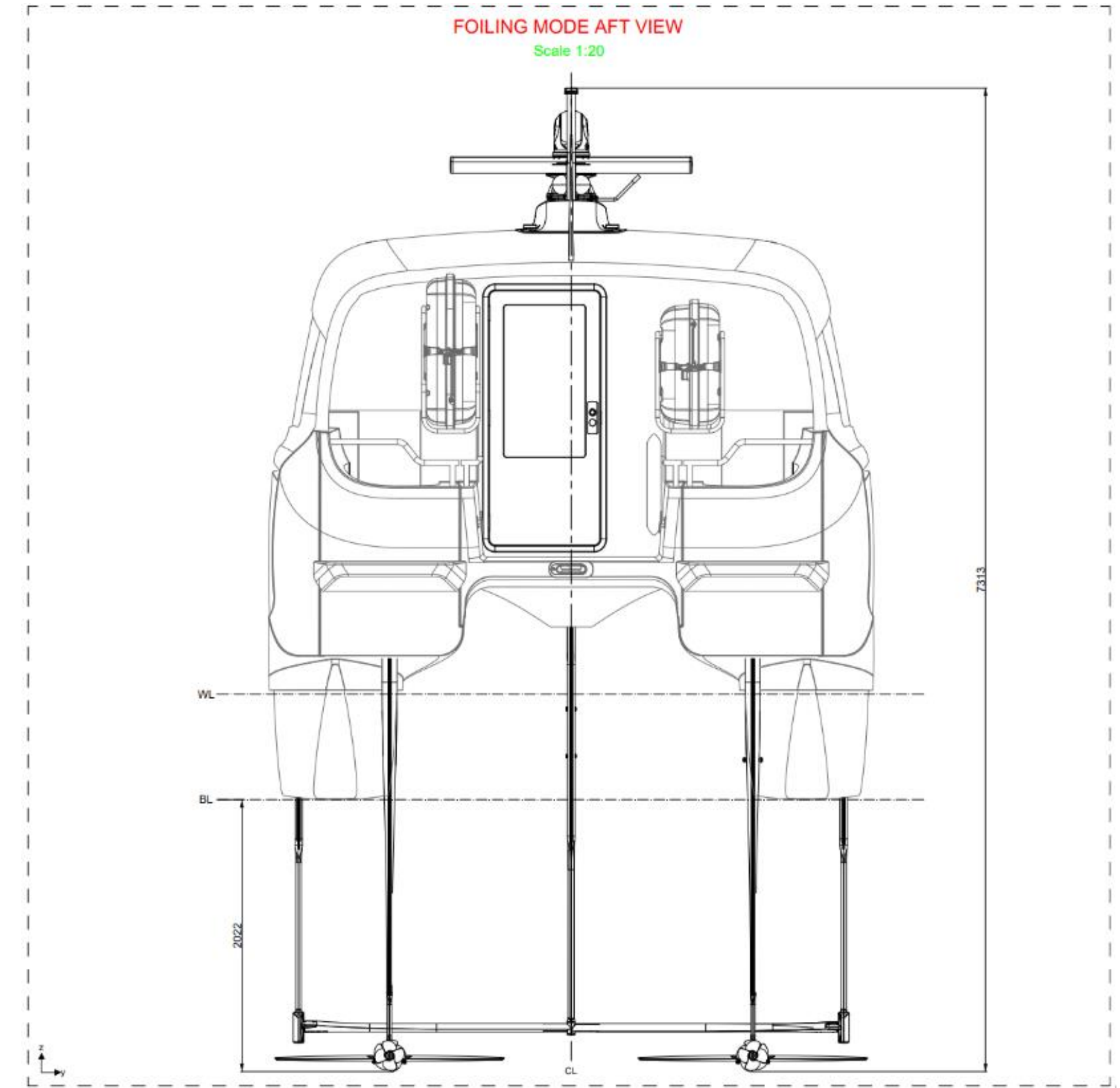
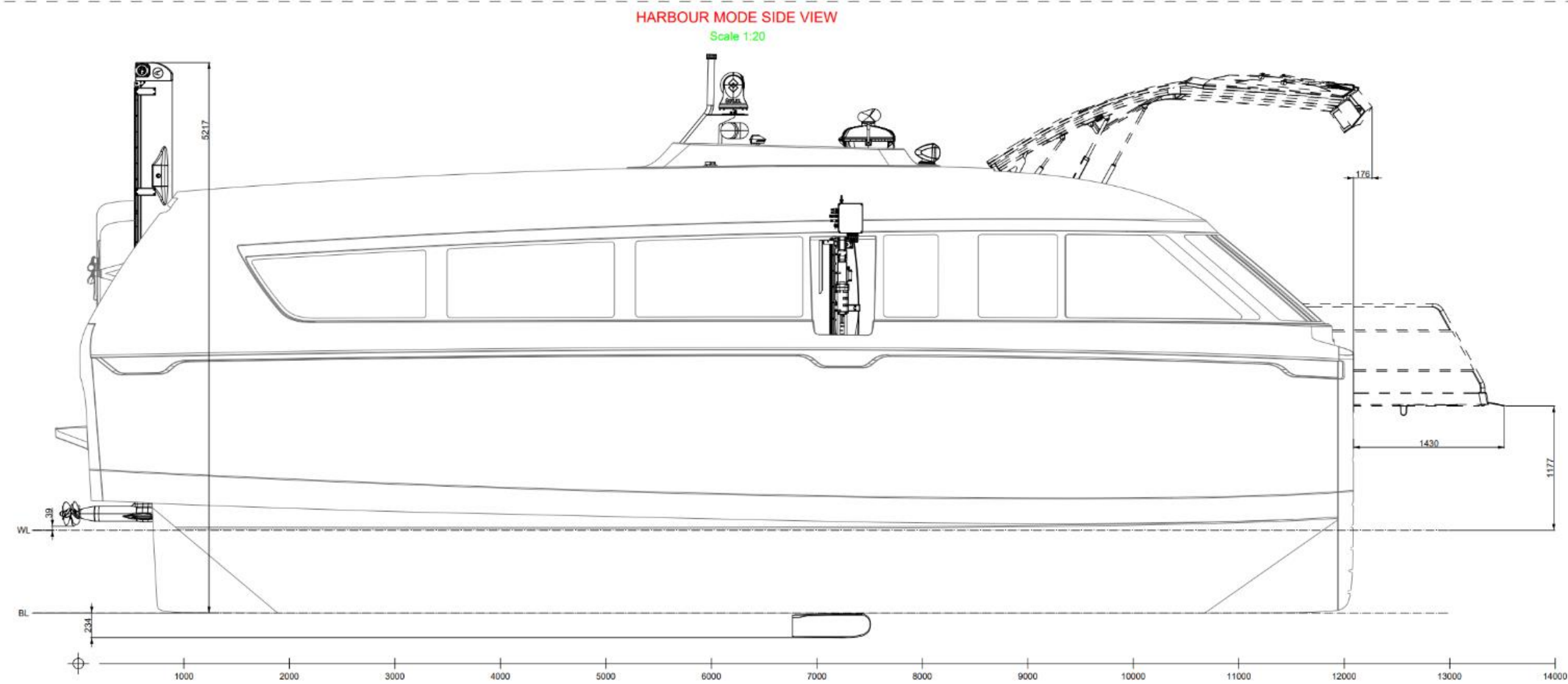

Compliance.

Certified against the highest standards.

The Candela P-12 Shuttle will have a Type approval- DNV Craft with passenger and battery notation. Rigorous attention has been taken to ensure compliance with regulatory frameworks and to guarantee passenger safety.

Operation:

Max significant wave height.

When foiling: Hs = 1M

Non-foiling: Hs = 2M

Max wind: Beaufort 6



DNV Classification

performs certification according to standard for commercial vessels
DNV-ST-0342



Sets requirements to:

- Section 1 General regulations – certification procedures**
- Section 2 Materials and manufacturing**
- Section 3 Structure and equipment**
- Section 4 System and components**
- Section 5 Safety requirements**

DNV Advisory

performs Technology Qualification of foil system according to DNV-RP-A203



Procedure:

- 1. Qualification Basis**
- 2. Technology Assessment**
- 3. Threat assessments (FMECA & HAZID/HAZOP)**
- 4. Qualification Plan**
- 5. Execution of qualification plan**
- 6. Performance assessment**

Outcome:

Statement technology qualified

Gives evidence that the technology meets the specified requirements for the intended use

Outcome:

Type approval certificate for vessel design

Boat certificate for individual boats



Boarding System



Docking.

Service speed to service speed in two minutes.

The flexible ramp system in both height and length can be used with the vast majority of docks. The adaptability of the ramp and the retractable foil system makes it possible to access most docks without major infrastructure investments.

it possible to have a swift turn-around to keep docking time to a minimum. A full sequence from service speed to docking to on/offloading and back to service speed can be carried out in under 2 minutes.

The 1.5-meter-wide ramp makes it possible to have simultaneous boarding and offloading. It is fully wheelchair and handicap compliant.

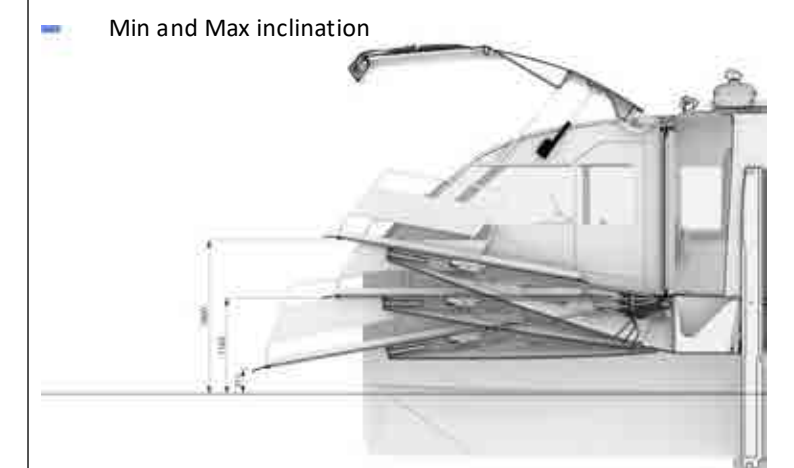
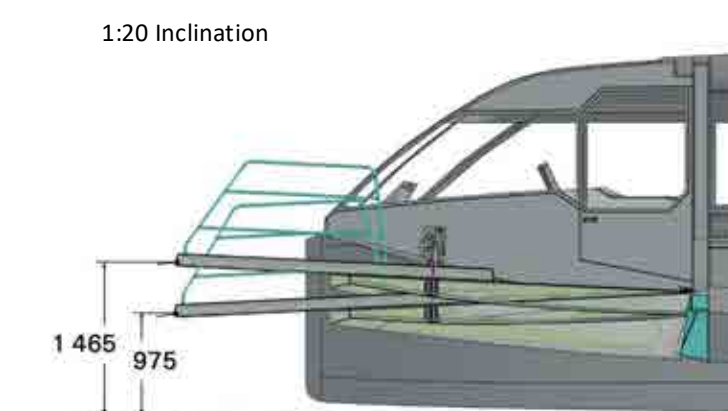
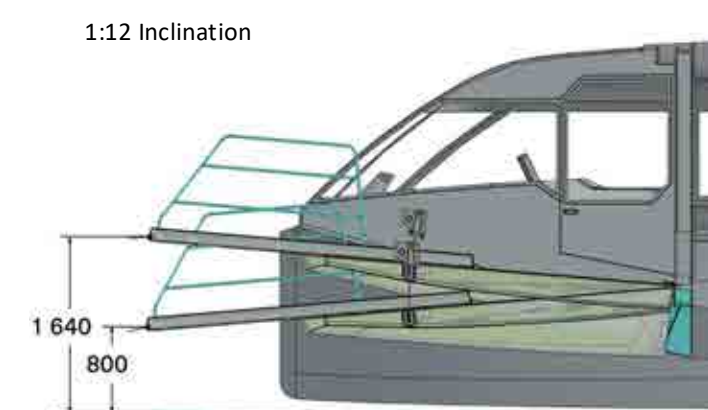

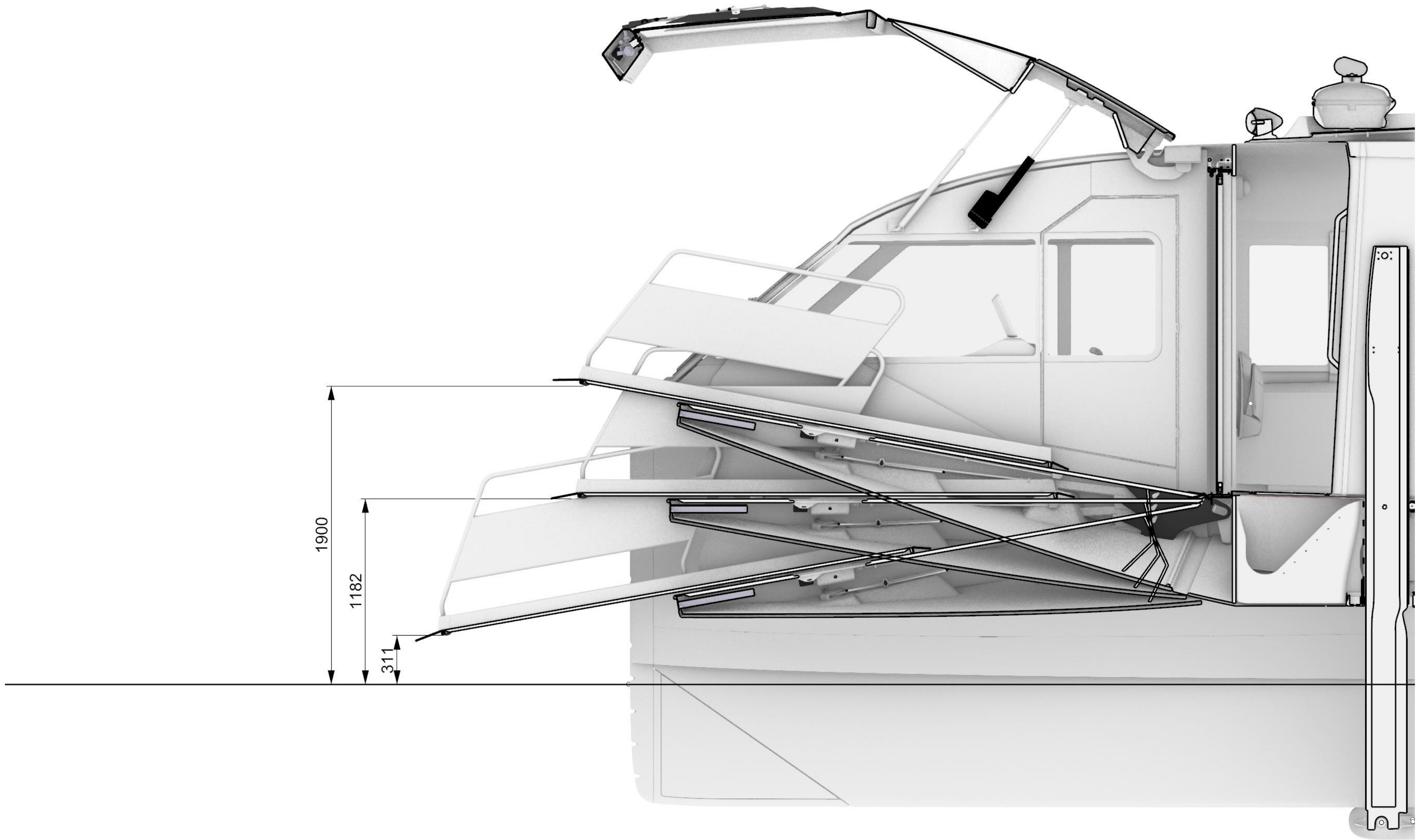

P-12 docking for passenger pickup (no line mooring)

CASE 1



Speedy boarding concept explanation

- Vessel is designed to be operated by 1 Crew (the *captain*) when in regular traffic.
- Vessel is designed for fast boarding operations during regular traffic – not requiring the captain to leave the helmstation.
- Captain is able to fully control the entire boarding sequence from the helmstation and is not required to physically leave the helmstation during boarding operations.
 - *Boarding ramp is adjustable from the helmstation*
 - *Constant contact to the pier during boarding is ensured by engaging thrust and/or heading autopilot*
 - *Captain communicates to land / cabin via PA*
 - *Front bumpers allow to avoid fendering.*

Speedy boarding Operating procedure

1. Vessel approaches dock
2. Captain opens front door and prepositions boarding ramp with button controls
3. Vessel makes contact and pushes against dock (no fendering or mooring lines needed – bow protected by bumper)
4. Boarding Ramp is adjusted/extended towards the dock
5. Passengers board/offboard via boarding ramp
6. Boarding ramp is retracted
7. Vessel leaves dock



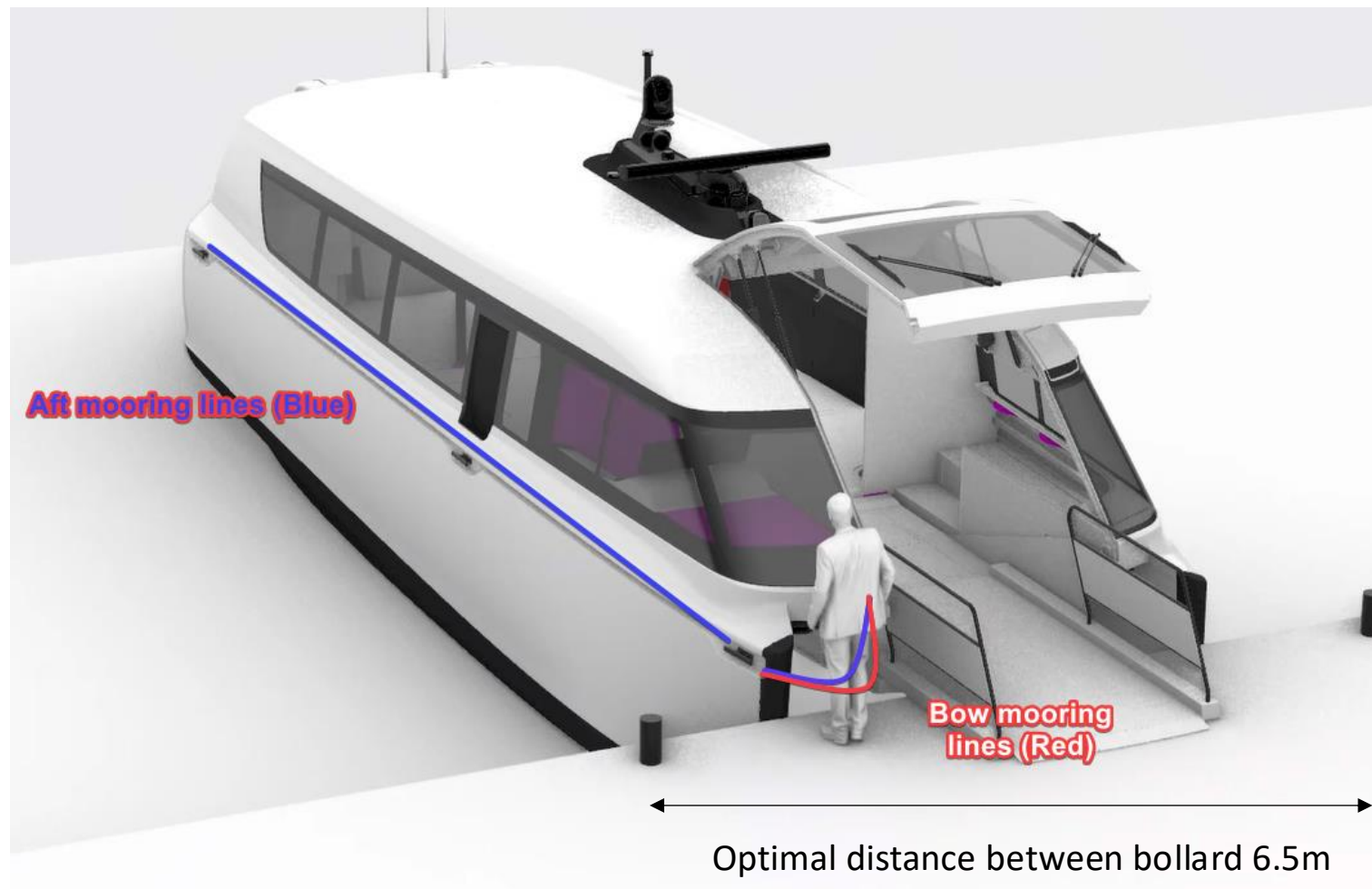

1

Approaching dock

- Captain maneuvers vessel towards dock and adjusts ramp to dock height
- Aft mooring lines are tied to aft cleats and pulled forward to bow cleat while under way. They are stored together with bow lines, in an easy-access location (e.g. in companionway)
- Hull protection towards dock is guaranteed by bow bumpers

2

Mooring the bow lines

- Captain holds position towards dock by engaging forward thrust
- Land crew grabs bow mooring lines from storage area and ties to bollard
- Vessel is moored well enough to disengage thrust

3

Mooring the aft lines

- Captain or land crew untie the aft mooring lines from the bow cleats
- Aft mooring lines are tied to bollard – vessel is fully moored
- Shore charging is connected at this stage

1-crew procedure. *The captain shall approach dock, extend platform, engage heading control & light thrust towards dock and quickly moor the vessel at the two front cleats while controls are unattended for a short time. Throttle can then be released, and aft lines are secured at a second stage.*

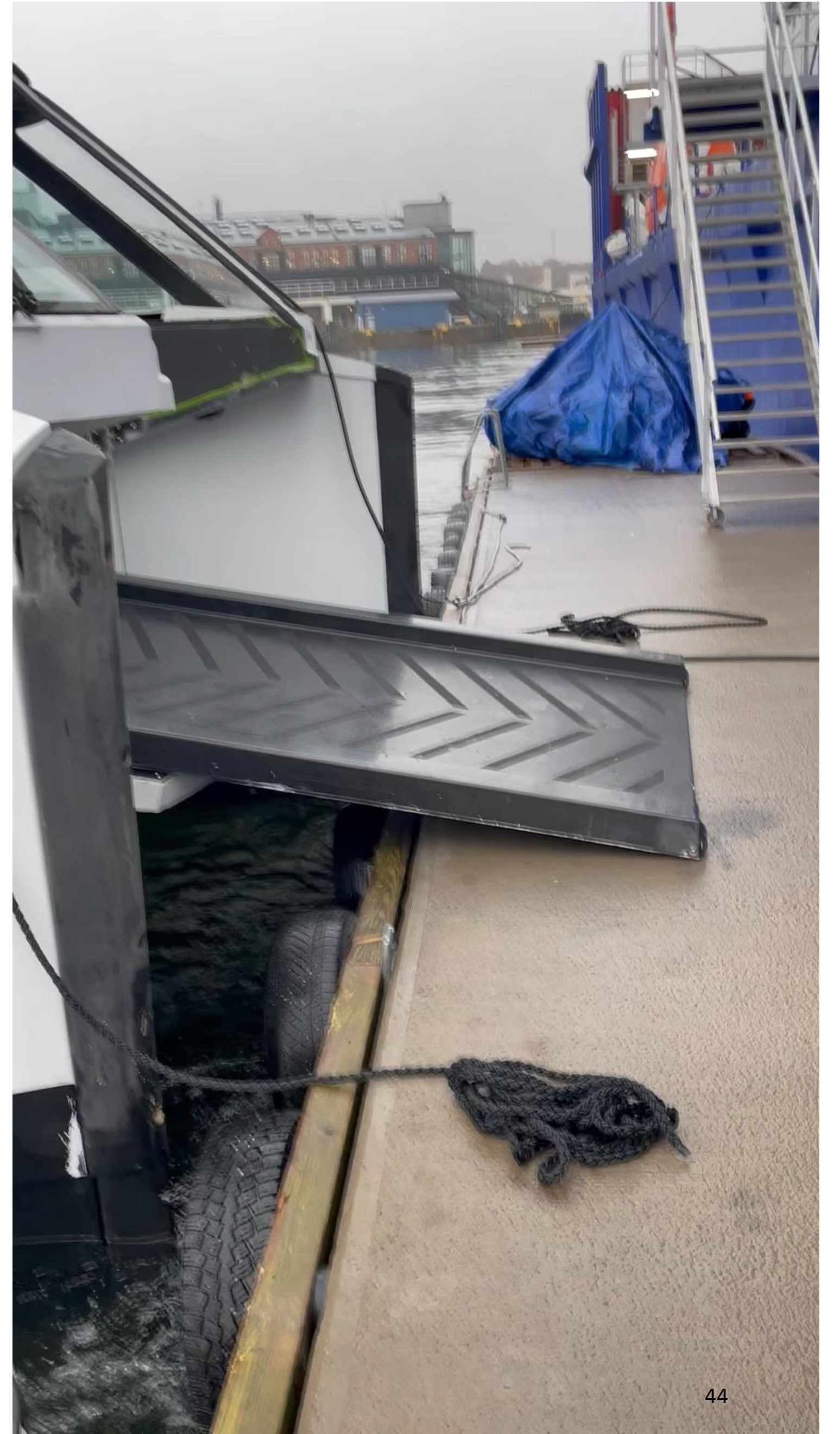

Easy docking.



CANDELA



Smart Water Mobility



100% electric hydrofoil

Infrastructure Requirements

Candela P-12 is designed for standard off-the-shelf charging requirement (CCS Type 2), same standard as the electric car industry. The front ramp is also highly flexible, meaning off- and onboarding can be done at multiple dock-heights lowering infrastructure investments. See details below.

Charging:

2 x 100 kW CC2 Type 2 Connectors is recommended:

Being able to offer a fairly “simple” DC charging infrastructure (compared to other vessels)
Short leadtimes, “off-the-shelf” solution, much lower landside investment.

The max setup is

- Battery capacity is 4x63 kWh nominal, 59 kW useable.
- Proposed charging setup (factoring losses and hotel load) up to 200 kW dual (2x 100 kW connection points), reference Kempower C501-P160-CC-7-D-S-D2-C0
<https://mediabank.kempower.com/l/DcX6Pmmkg6RZ>
- Gives a charging time of
 - 20%-80” = ~50 minutes
 - 0%-80% = ~75 minutes
 - 0%-full = ~105 minutes



Service.

A fraction needed compared to conventional vessels.

The P-12 Shuttle is built to need as little service and maintenance as possible. This to ensure maximum uptime at the lowest costs. Should something happen, support is always close by wherever you are.

Customer support

- Remote diagnostics and troubleshooting.
- Over 200 data points can be analyzed and turned into corrective actions.

Scheduled service

- Candela technicians are available for onsite visits.
- Scheduled maintenance est. every 3000hrs.

Local Service and Maintenance

- Training of local technical staff can be provided.

Spare parts

- Off-the-shelf spare part availability.
- Possibility to order and keep stock locally.





Candela P-12 Cargo

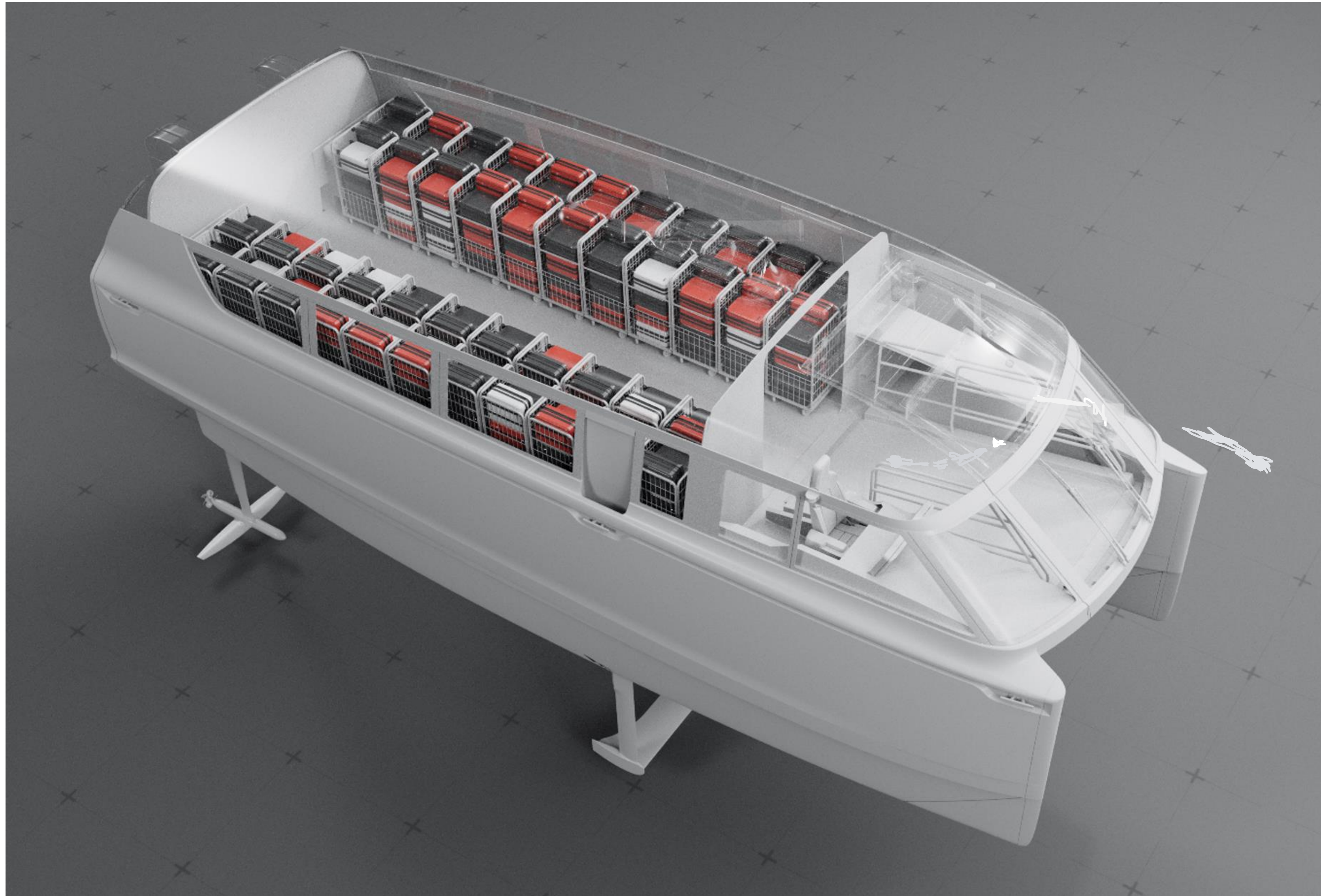

Cargo capacity:
45 m³; 3 tons



CANDELA



Candela P-12 advertisement space

Design Example

– Exterior Branding for Sponsors and Commercials: 81,2 square meters



Example 2



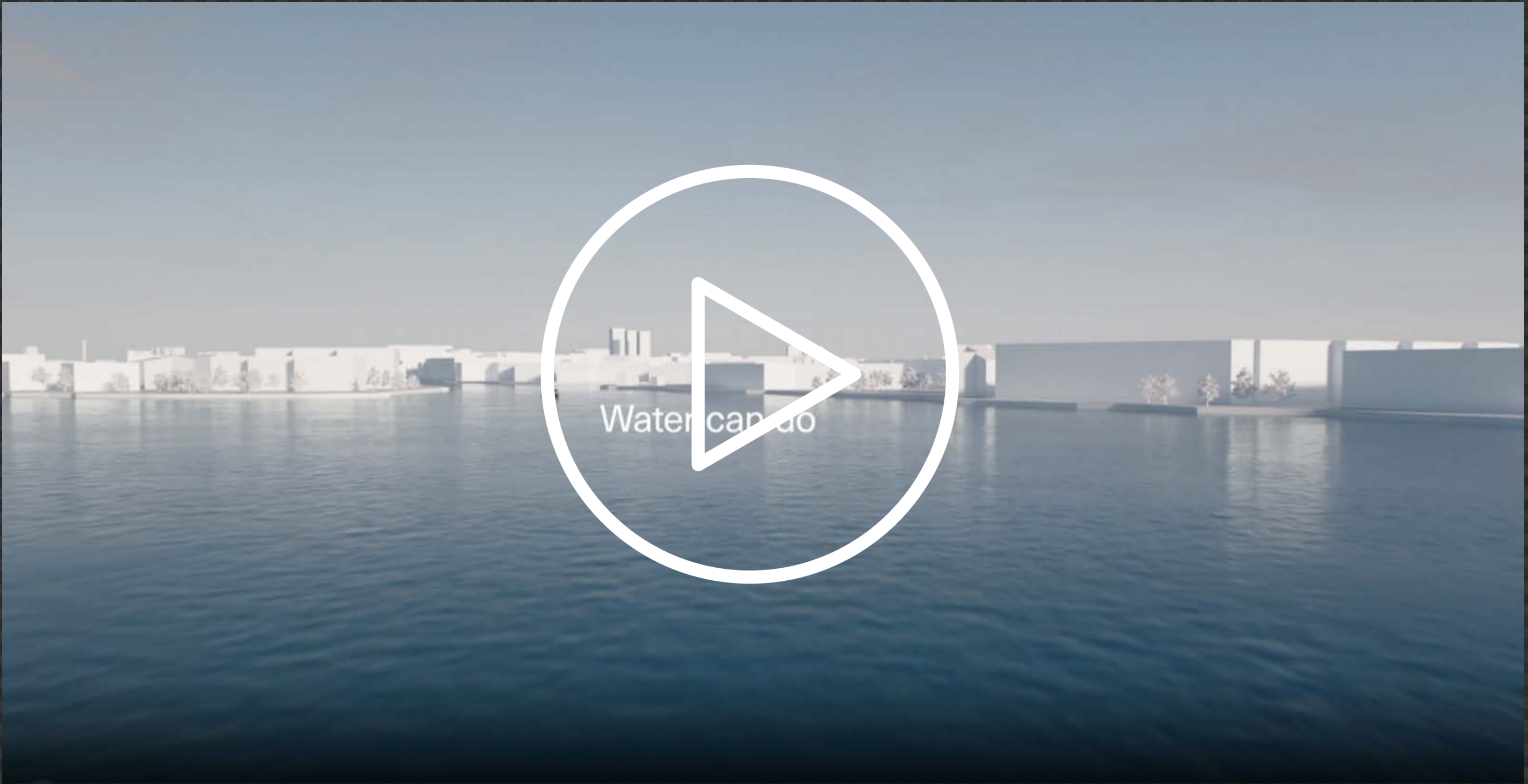

Water can do

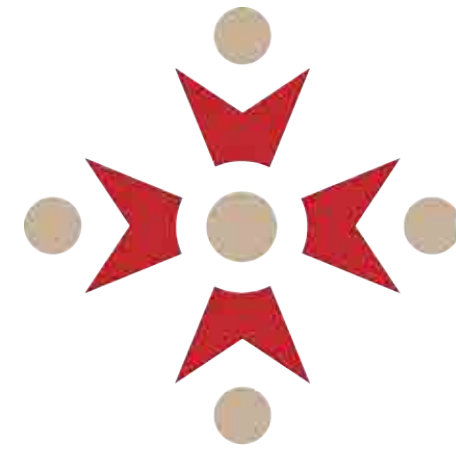

TW CONSULTING
& TRADE LTD.

Exclusive Importer for Malta

Wolfgang Tweraser
CEO/President

Tel EU: +356 2701 9052 (office)
Tel EU: +356 9942 9829 (mobile)

wolfgang@TWCTMT.com

www.TWCTMT.com

CANDELA