

VARIOfit®

2021

The perfect form
of transport



colours.

Proven since 2011! From 2017 . . .



. . . standard!

For you, our proven **EasySTOP** central brake system, available since 2011, will be fitted as standard to virtually all **VARIOfit**® trucks and trolleys.

Use this to your advantage and set yourself apart from the competition.



Contents

VARIOfit® colours.

Trolleys, Dollies, Trucks, Handling of steel-cylinder trucks, Handling of drums, Handling of pallets	14-67	Tyre handling	Tyre trucks	186-187
Trolleys			Tyre rack, Tyre trolley	187-189
Platform trolleys, Push bar trolleys, System trolleys with board sides/mesh sides	69-74	Handling of steel-cylinder trucks	Steel-cylinder trucks	190-192
Heavy-duty trolleys, Long-goods trolley/dolly	75-77		Steel-cylinder trolleys	192
Folding push bar trolleys	78-79	Handling of drums	Drum dollies, Drum trucks, Drum trolley	194-196
C+C trolleys	80		Drum dispenser	197
Box trolleys	82-83		Drip trays, Push bar trolley with drip tray	198
Side-frame trolleys, Tubular-support trolley, Sheet-material trolley, Sheet-material stand, Sheet-material trucks	84-87	Loading and unloading	Bridge plate, Ramp	199
Workpiece trolleys, Carrier-spar trolleys	88-91	Disposal	Self-tipper	200
Table trolleys	92-99		Waste collection stand, Cleaning trolley	201
ESD trolleys	101-109	Handling of pallets	Steel frame dollies, Tipping unit for steel frame dollies	202-205
Workshop trolleys	110-117		Pallet converters	206-213
Shelf trolleys, Parcel trolleys	118-134	Dollies	Dollies, Dolly collector	214, 217
Euro container trolleys, Small order-picking trolleys, Material stands	135-141		Dollies Europa	215
Document trolleys, Book trolley	142-143		Dollies with grooved rubber mat bonded to load surface, Triple-Dogs	216
Order-picking trolleys	144-145	Wheels and castors	Wheels, castors and bearings, Characteristics of castors	218-219
Hand trucks, Roll truck, Roll stand, Bicycle trailer	146-148		Summary of castors	220-223
Hand platform trolleys	149-151	Accessories	Accessories for trucks	224
Industrial trailers	152-153		General accessories	225
Dollies		Index	Index	226-228
Crate dollies	154			
Euro system dollies	156-161			
Push-handle dollies	162-163			
Quick-lift jacks	164-165			
Two-wheeled platforms				
Trucks				
Tubular-steel trucks	166-172			
Aluminium trucks	173-175			
Stair-climber trucks	176-177			
Aluminium stair-climber trucks	178-179			
Chair trucks, Furniture trucks	180			
Table transporter	181			
Appliance trucks, Heavy-duty truck	182-183			
Lightweight folding truck, Parcel trucks	185			

12 up to **years** warranty

12 years 2 years

The strong manufacturer



Behind every strong brand is a strong manufacturer



VARIOfit® lets you and your customers profit from the flexibility of an experienced manufacturer.

Everything started when the company was set up in 1960 and the first trolley was patented: the Möbelhund® (the furniture mover). Continuing developments, TÜV certifications, a complex in-house, partially automated powder coating plant in addition to expansion of product and production facilities have made CORDES into a manufacturer that is a competent partner for the specialist trade and its users at all times.

Our almost 550 employees process around 800 metric tons of steel a month on a footprint of approximately 85,000 m² and on a production and stacking ground of 43,000 m².



Thanks to proven logistics and our narrow-aisle warehouse with more than 7,000 pallet bays served by the latest equipment, direct delivery of even large quantities is no problem.

Our standard items leave our warehouse within 48 hours and with some 2,000 truckloads a year, as well as neutral delivery direct to the end customer, CORDES is a byword for fast and reliable delivery thanks to an efficient logistics chain.



As a result, CORDES stands for quality products and for speedy, reliable delivery based on an efficient logistics chain.



VARIOfit.eu



The eight

Convince yourself of the perfect form of transportation



Modular system

Four basic platforms of different sizes form the base for sturdy bolt-on fitting of almost all superstructures. **VARIOfit** products bearing this symbol allow trouble-free modification to cater for changed requirements. This keeps **VARIOfit** affordable for the customer and ensures that it maintains its value.



Innovative L-section frames

Only **VARIOfit** trucks have the L-section frame developed exclusively by CORDES to ensure maximum load-bearing capacity. This specially designed frame makes **VARIOfit** trucks and trolleys extremely robust and light.



Facility and safeness

Thanks to their new wheels with thermoplastic tyres, **VARIOfit** trucks and trolleys leave no marks even on light-coloured floors. Their sealed precision ball bearings of deepgroove design are not only robust and impact-resistant, but also extremely easy-running. And it goes without saying that their swivel castors are equipped with wheel brakes and foot guards as required by EU standards.



EasySTOP central brake system

The first central foot brake. Since 2011 it has been possible to bring trolleys to a stop in this easy but safe manner.



Special equipment!

VARIOfit, as the name suggests, stands for unusually variable trucks and trolleys. In addition to its special product variants, **VARIOfit** offers virtually unlimited possibilities for modification to suit customers' individual wishes.

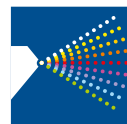

Powder coating

After thorough preliminary treatment, **VARIOfit** products are powder coated, then stove enamelled to optimise and enhance their surface finish. This makes them resistant to impacts and scratches and gives them the robustness they need for a long service life.



Logistics chain

With its efficient logistics chain, CORDES supplies direct to the end customer. This guarantees speedy delivery. It also means that products are normally dispatched within 5 working days - and the customer can depend on it.



TÜV mark

TÜV (the German technical inspection authority) stands for quality and safety. Most **VARIOfit** products bear this mark. The TÜV mark can be awarded to trolleys with a payload of up to 500 kg and trucks with a capacity of 250 kg.



Customizing



Customizing - our daily business!

VARIOfit® is the brand for especially variable materials handling equipment. In addition to these product variants, **VARIOfit**® offers almost unlimited opportunities for modification in line with customers' individual wishes.

In a generous extended production department for special equipment we have created the possibility of offering and supplying not only the usual large quantities, but also sample items and small series (from one piece upwards). Our service includes product approval drawings, short delivery times and reasonable prices.

Every day we develop and produce special equipment in line with customers' requirements. In close cooperation with our customers we analyse parameters such as uses, handling, workflows etc. to design the „made to measure“ equipment for the goods you want to transport. A locally business call is for us self-evident.

We offer you products in ...

- Special sizes
- Special colours
- Complete new design for customer-specific applications

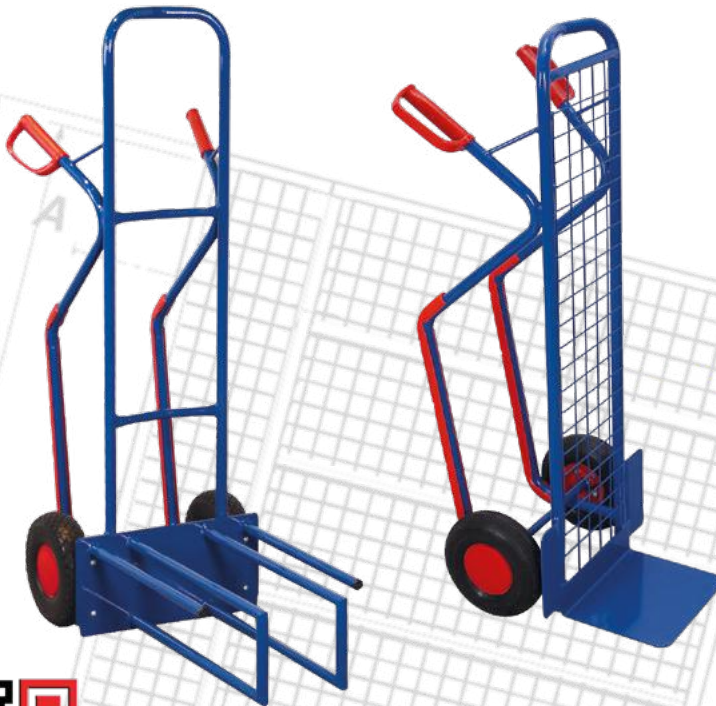

VARIOfit®
Customizing



From the beginning all from one hand

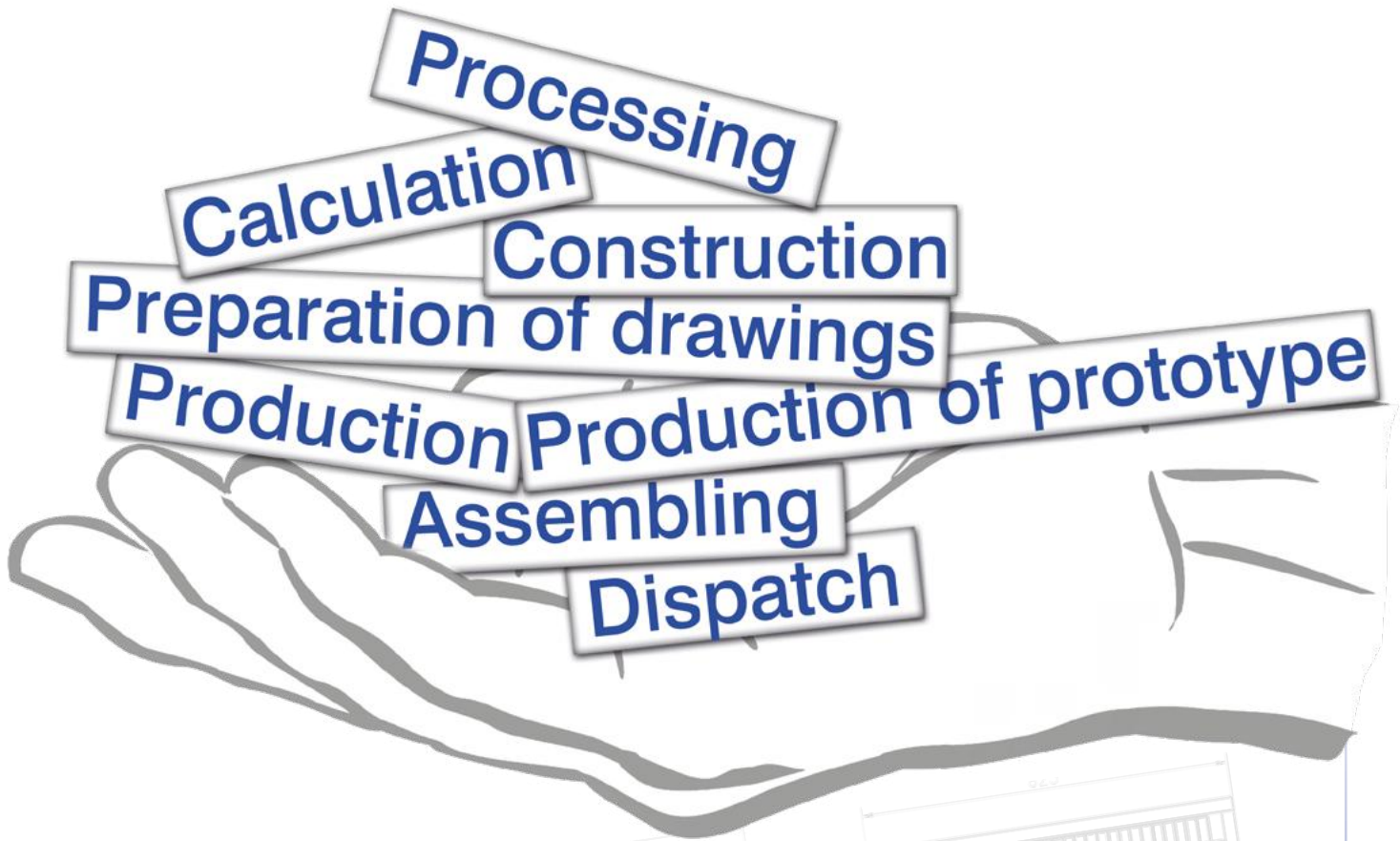

Special colour - depending on the purpose!

Customize the transport devices not only technically, but also optically to your wishes, requirements and circumstances.

"Corporate Identity" is only one of many reasons for opting out of the standard.

In the usual **VARIOfit**[®] quality, after thorough pretreatment, the finishing of the surface takes place in our automatic powder coating system.

The powder coating ensures permanent surface protection as well as impact- and scratch-resistance.

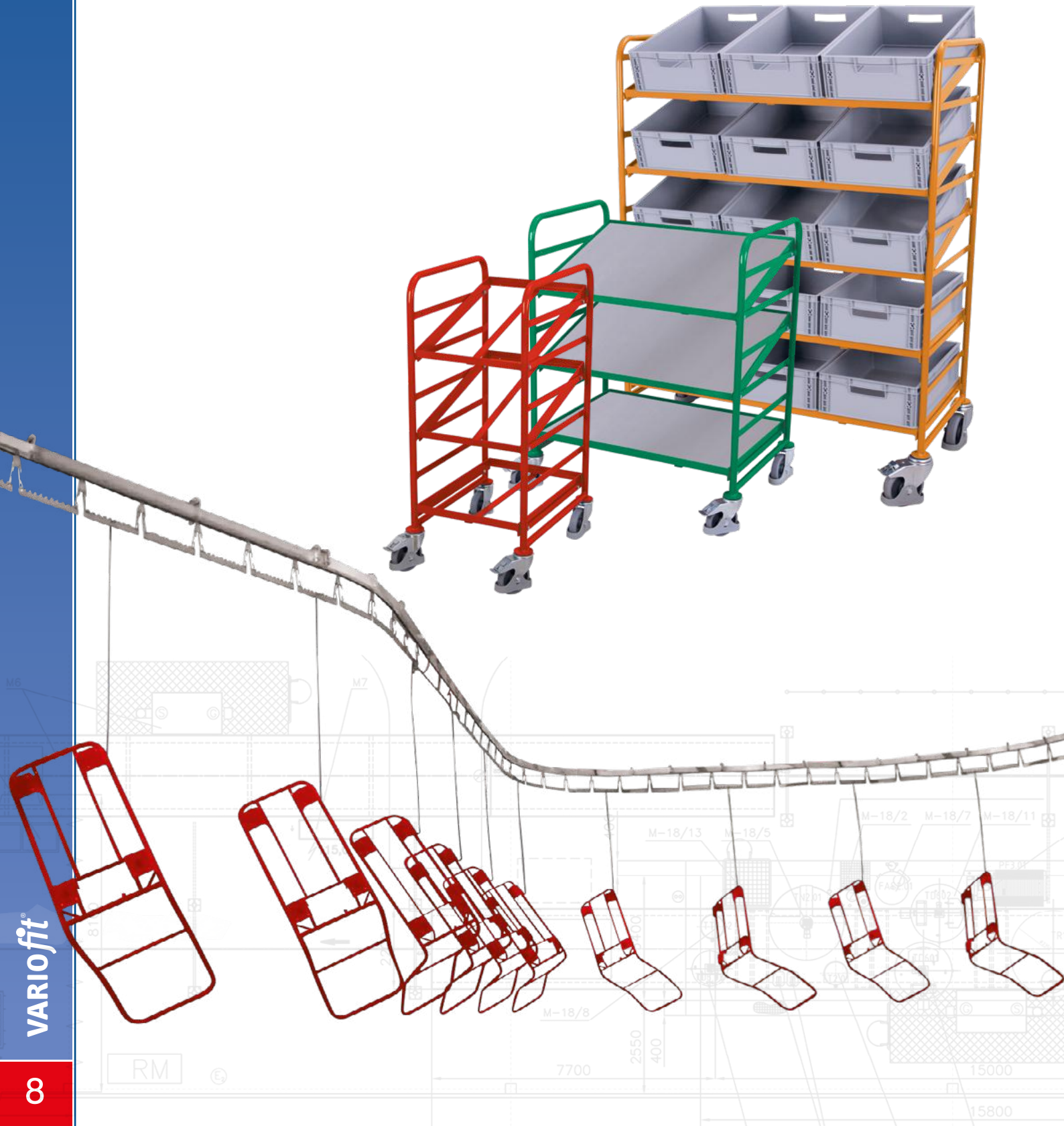

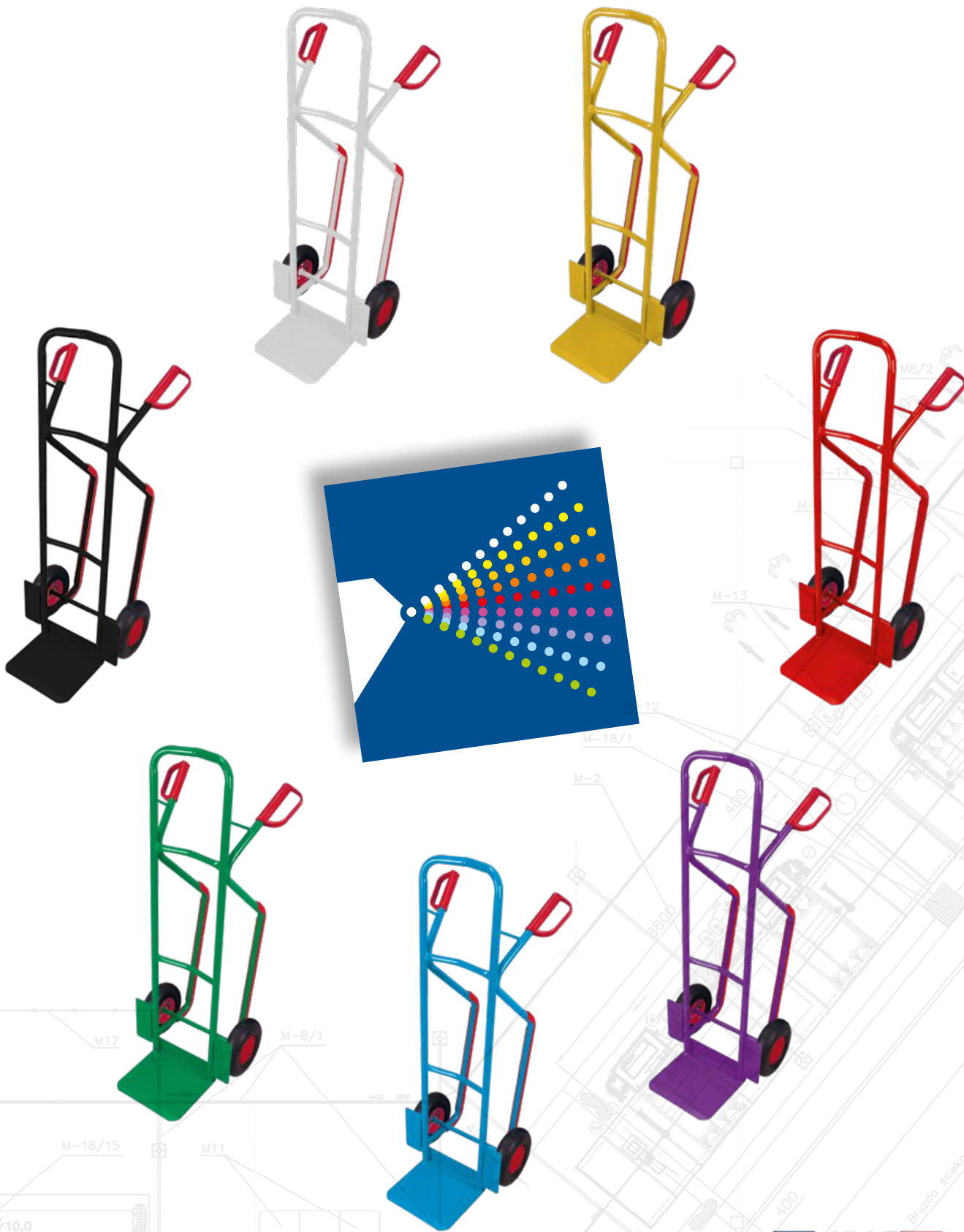

VARIOfit[®]
Special colour



Easy runners, distance no problem

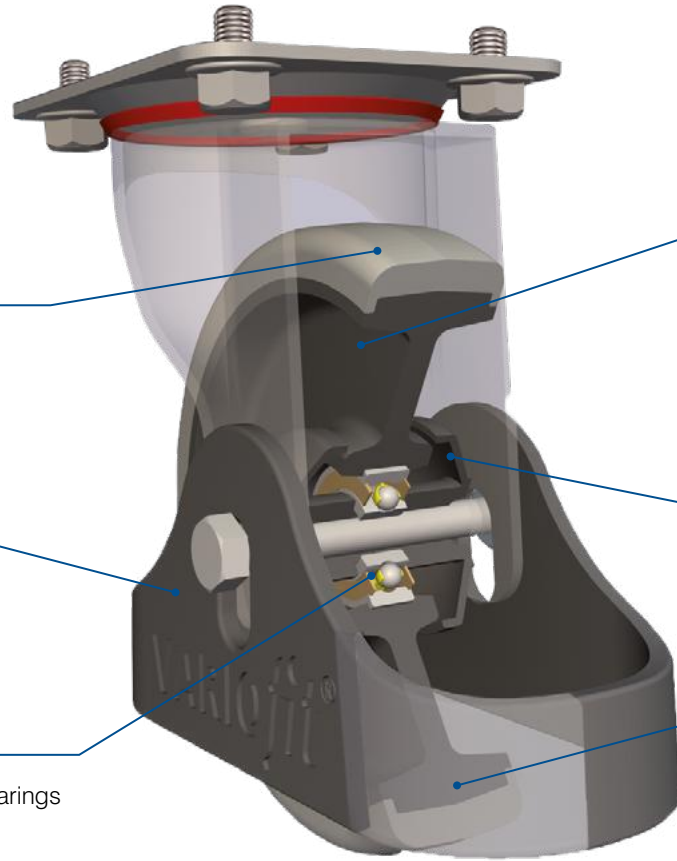

Running surface:
Grey, non-marking thermoplastic rubber

Hygiene:
Low dirt pick-up and easy to clean due to flat wheel rim

Foot guard:
Standard equipment, of course

Thread guard:
Minimises uptake of threads lying on the floor

Long life:
Sealed precision deepgroove ball bearings

Easy-runner wheel:
About 50% less initial and rolling resistance



VARIOfit
Easy runners

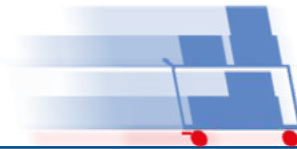

With their maintenance-free precision deepgroove ball bearings and optimised tyres, these **VARIOfit**® wheels offer about 50% less initial resistance than normal castors. So the truck is easy to start moving even when heavily loaded. This saves time, money and effort in day-to-day use. And of course only **VARIOfit**® supplies them as standard with the **VARIOfit**® foot guard.

Conventional wheels need a lot of strength to set the truck in motion and keep it moving.



VARIOfit® easy-runner wheels: they need a minimum of effort to get the truck moving, even when heavily loaded. That also means less effort when pushing and reduces materials handling times.

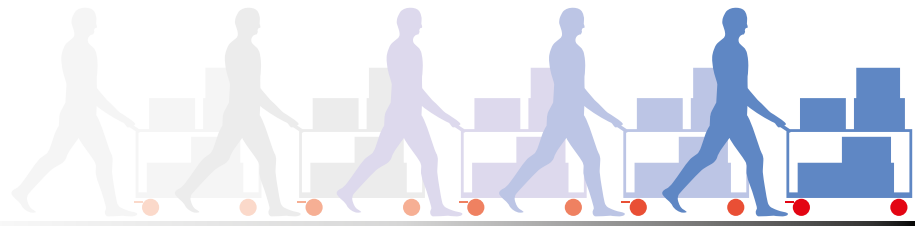

Combined with **EasySTOP**, the perfect solution

Dead man's brake

The **VARIOfit**® dead man's brake provides a further braking system. The design is typically **VARIOfit**®: high quality, smooth and user-friendly. The design was chosen so that the Bowden cable is integrated in the push bar and all parts of the brake system are inside the truck or trolley contours. As a result, there are no protruding parts that could interfere with the operator when using the truck or trolley. The truck or trolley is always braked and secured against rolling away unintentionally until the push bar is depressed and the dead man's brake is thus released. On releasing the push bar, the dead man's brake is activated automatically and the truck or trolley is braked safely again. The additional handle beneath the push bar allows an ergonomic movement of the trucks when the brake is released.

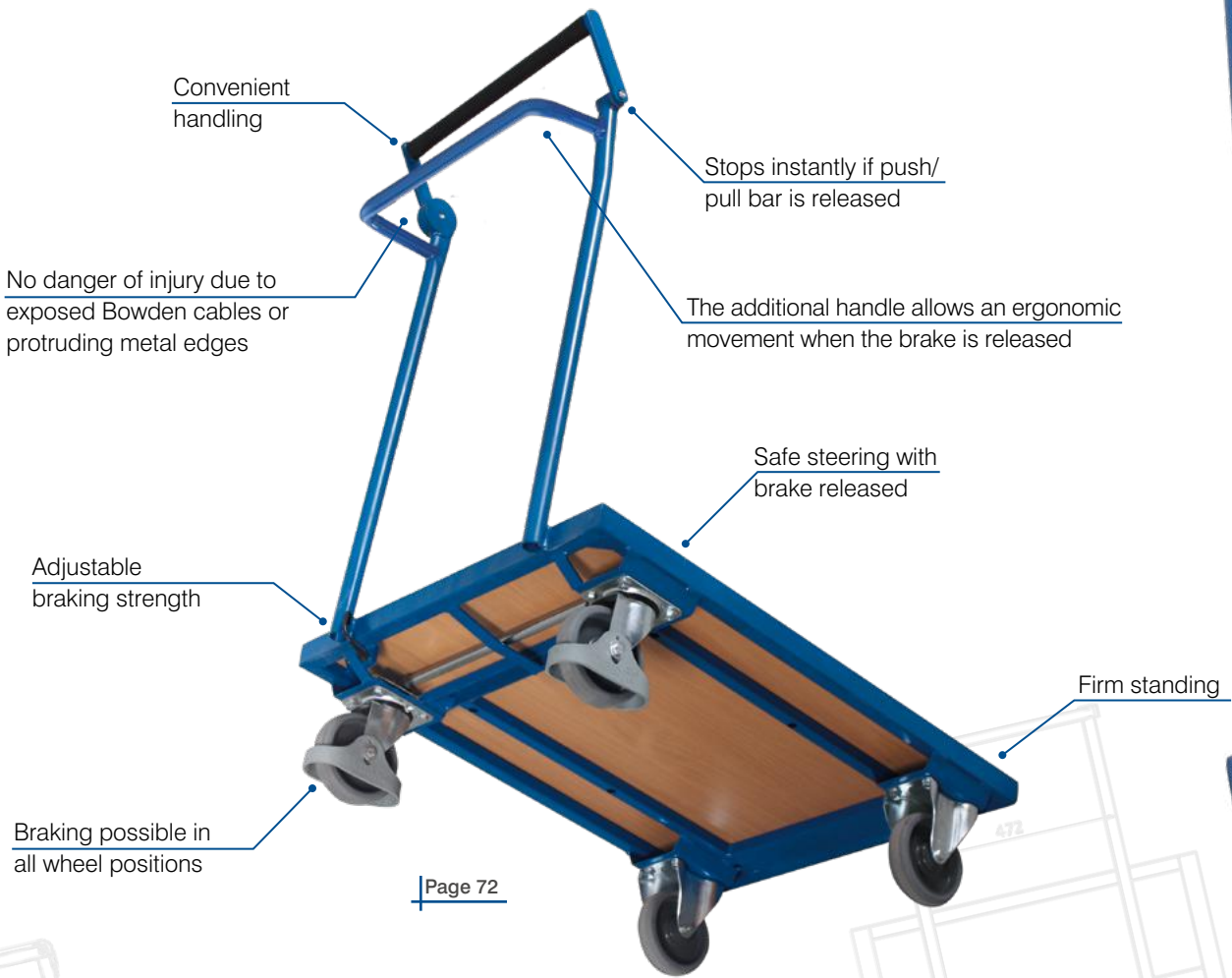
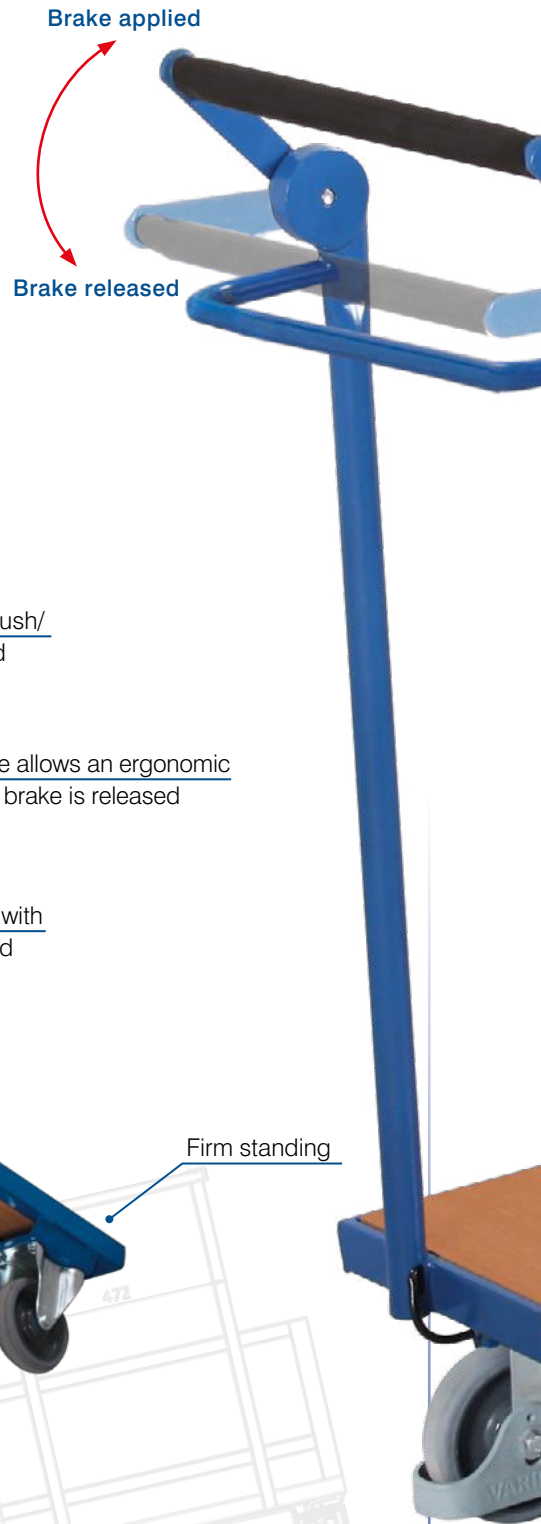

Page 72



Page 78



Page 93



Page 120



Page 126



Page 192



Page 195

Central foot brake

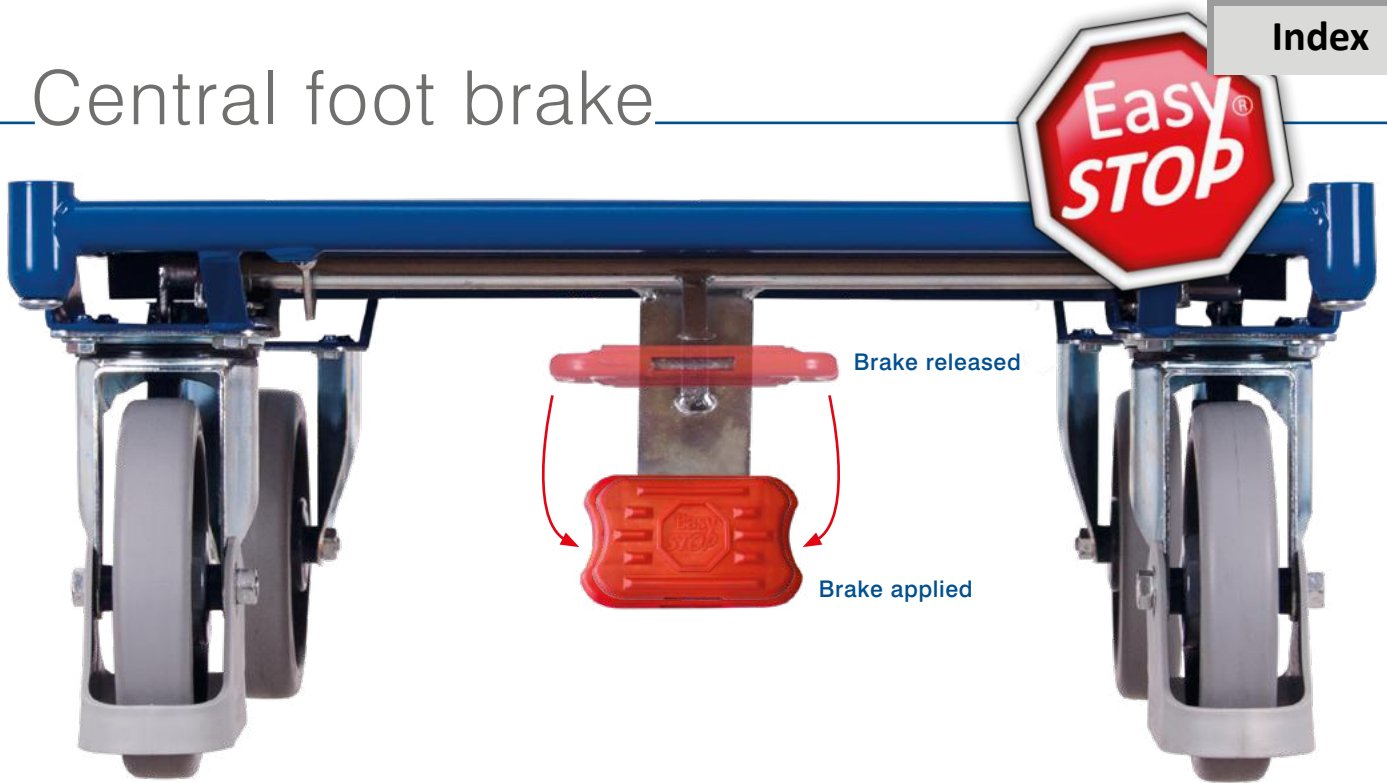

Since 2017 standard in nearly all **VARIOfit**® trucks and trolleys!

- **Easy stop:** Simply press the **EasySTOP** brake once - this arrests both swivel castors
- **Easy go:** Return the pedal to it's starting position - quick and easy
- **Safety:** Fixed position with easy access by trolley operator permits instant braking
- Adjustable braking action
- Pedal can be operated with normal shoes or safety footwear
- Braking always possible regardless of wheel position
- Firm standing
- **Ergonomic:** Light actuation, short travel



Define the operating range yourself



Now our proven **EasySTOP** central brake system can also be operated from **2 sides**. The truck or trolley can be customized as required to satisfy local conditions perfectly.

Stay flexible and benefit from a number of advantages:

- Being able to apply and release the central brake from both sides means you can brake either 2 wheels or all 4 wheels with only one pedal operation
- When combined with a drawbar, the central brake is automatically released on hitching up
- 4 swivel castors ensure more manoeuvrability even in narrow spaces and decrease the turning circle

TWO is **BETTER** ... Use all advantages of our Double **EasySTOP** central brake system



This . . . is ONLY available with **VARIOfit**

Push bar trolleys

Base structure of push bar trolleys with innovative frame section, or of round pipe; Folding push bar trolleys of welded steel construction with folding push bar; Load surface of wood-based board, surface coated in dark grey; Trolleys powder-coated RAL 7016 anthracite grey or RAL 7035 light grey; Permanent surface protection; Impact- and scratch-resistant; Grey non-marking thermoplastic rubber tyres on plastic wheel rim with precision deepgroove ball bearings; Thread guard and foot guard; 2 **EasySTOP** swivel castors and 2 fixed castors.



Push bar trolley, RAL 7016

Article no.	Dimension			Loading surface		Weight kg	Load cap. kg	Wheel diam. mm
	W	mm D	H	w	d			
sw-500.100/AG	975	500	975	880	500	25.0	400	160 x 40
sw-600.100/AG	1125	600	1015	1030	600	29.5	500	200 x 40
sw-700.100/AG	1125	700	1015	1030	700	33.5	500	200 x 40
sw-800.100/AG	1325	800	1015	1230	800	37.0	500	200 x 40

EasySTOP swivel castors and foot guards for your safety!



Push bar trolley, RAL 7016

Article no.	Dimension			Loading surface		Weight kg	Load cap. kg	Wheel diam. mm
	W	mm D	H	w	d			
sw-500.103/AG	950	500	990	850	500	23.5	400	160 x 40
sw-700.103/AG	1100	700	1030	1000	700	28.0	400	200 x 40
sw-700.104/AG	1300	700	1030	1200	700	32.5	400	200 x 40

EasySTOP swivel castors and foot guards for your safety!

Light version tubular steel push bar trolley, RAL 7016

Article no.	Dimension			Loading surface		Weight kg	Load cap. kg	Wheel diam. mm
	W	mm D	H	w	d			
sw-450.103/AG	950	450	945	850	450	17.0	200	125 x 32
sw-600.109/AG	1100	600	945	1000	600	22.5	200	125 x 32

EasySTOP swivel castors and foot guards for your safety!



Folding push bar trolley, RAL 7016

Article no.	Dimension			Loading surface		Weight kg	Load cap. kg	Wheel diam. mm
	W	mm D	H	w	d			
sw-450.802/AG	815	450	940	720	450	15.0	150	125 x 32
sw-600.802/AG	995	600	980	900	600	23.5	250	160 x 40

EasySTOP swivel castors and foot guards for your safety!



Push bar trolleys and folding push bar trolleys



Push bar trolley, RAL 7035

Article no.	Dimension			Loading surface		Weight kg	Load cap. kg	Wheel diam. mm
	W	mm D	H	w mm	d			
sw-500.100/LG	975	500	975	880	500	25.0	400	160 x 40
sw-600.100/LG	1125	600	1015	1030	600	29.5	500	200 x 40
sw-700.100/LG	1125	700	1015	1030	700	33.5	500	200 x 40
sw-800.100/LG	1325	800	1015	1230	800	37.0	500	200 x 40

EasySTOP swivel castors and foot guards for your safety!



Push bar trolley, RAL 7035

Article no.	Dimension			Loading surface		Weight kg	Load cap. kg	Wheel diam. mm
	W	mm D	H	w mm	d			
sw-500.103/LG	950	500	990	850	500	23.5	400	160 x 40
sw-700.103/LG	1100	700	1030	1000	700	28.0	400	200 x 40
sw-700.104/LG	1300	700	1030	1200	700	32.5	400	200 x 40

EasySTOP swivel castors and foot guards for your safety!



Light version tubular steel push bar trolley, RAL 7035

Article no.	Dimension			Loading surface		Weight kg	Load cap. kg	Wheel diam. mm
	W	mm D	H	w mm	d			
sw-450.103/LG	950	450	945	850	450	17.0	200	125 x 32
sw-600.109/LG	1100	600	945	1000	600	22.5	200	125 x 32

EasySTOP swivel castors and foot guards for your safety!



Folding push bar trolley, RAL 7035

Article no.	Dimension			Loading surface		Weight kg	Load cap. kg	Wheel diam. mm
	W	mm D	H	w mm	d			
sw-450.802/LG	815	450	940	720	450	15.0	150	125 x 32
sw-600.802/LG	995	600	980	900	600	23.5	250	160 x 40

EasySTOP swivel castors and foot guards for your safety!



System trolleys with board sides

Modular system; Base structure with innovative frame section; Load surface, end and side walls of wood-based board, surface coated in dark grey; Side walls 500 mm high and removable; Trolleys powder-coated RAL 7016 anthracite grey or RAL 7035 light grey; Permanent surface protection; Impact- and scratch-resistant; Grey non-marking thermoplastic rubber tyres on plastic wheel rim with precision deepgroove ball bearings; Thread guard and foot guard; 2 **EasySTOP** swivel castors and 2 fixed castors.



Single-end trolley with board, RAL 7016

Article no.	Dimension			Loading surface		Weight kg	Load cap. kg	Wheel diam. mm
	W	mm D	H	w mm	d			
sw-500.102/AG	975	500	975	880	500	26.0	400	160 x 40
sw-600.102/AG	1125	600	1015	1030	600	30.0	500	200 x 40
sw-700.102/AG	1125	700	1015	1030	700	33.0	500	200 x 40
sw-800.102/AG	1325	800	1015	1230	800	39.0	500	200 x 40

EasySTOP swivel castors and foot guards for your safety!



Double-end trolley with board, RAL 7016

Article no.	Dimension			Loading surface		Weight kg	Load cap. kg	Wheel diam. mm
	W	mm D	H	w mm	d			
sw-500.202/AG	1040	500	975	850	500	30.5	400	160 x 40
sw-600.222/AG	1190	600	1015	1000	600	34.5	500	200 x 40
sw-700.202/AG	1190	700	1015	1000	700	40.0	500	200 x 40
sw-800.202/AG	1390	800	1015	1200	800	45.5	500	200 x 40

EasySTOP swivel castors and foot guards for your safety!

Three-sided trolley with board, RAL 7016

Article no.	Dimension			Loading surface		Weight kg	Load cap. kg	Wheel diam. mm
	W	mm D	H	w mm	d			
sw-500.302/AG	1040	500	975	850	475	38.0	400	160 x 40
sw-600.302/AG	1190	600	1015	1000	575	45.0	500	200 x 40
sw-700.302/AG	1190	700	1015	1000	675	48.5	500	200 x 40
sw-800.302/AG	1390	800	1015	1200	775	56.0	500	200 x 40

EasySTOP swivel castors and foot guards for your safety!



Four-sided trolley with board, RAL 7016

Article no.	Dimension			Loading surface		Weight kg	Load cap. kg	Wheel diam. mm
	W	mm D	H	w mm	d			
sw-500.400/AG	1040	500	975	850	450	43.5	400	160 x 40
sw-600.400/AG	1190	600	1015	1000	550	51.0	500	200 x 40
sw-700.400/AG	1190	700	1015	1000	650	54.0	500	200 x 40
sw-800.400/AG	1390	800	1015	1200	750	61.0	500	200 x 40

EasySTOP swivel castors and foot guards for your safety!



System trolleys with board sides



Single-end trolley with board, RAL 7035

Article no.	Dimension			Loading surface		Weight kg	Load cap. kg	Wheel diam. mm
	w	mm D	H	w mm	d			
sw-500.102/LG	975	500	975	880	500	26.0	400	160 x 40
sw-600.102/LG	1125	600	1015	1030	600	30.0	500	200 x 40
sw-700.102/LG	1125	700	1015	1030	700	33.0	500	200 x 40
sw-800.102/LG	1325	800	1015	1230	800	39.0	500	200 x 40

EasySTOP swivel castors and foot guards for your safety!



Double-end trolley with board, RAL 7035

Article no.	Dimension			Loading surface		Weight kg	Load cap. kg	Wheel diam. mm
	w	mm D	H	w mm	d			
sw-500.202/LG	1040	500	975	850	500	30.5	400	160 x 40
sw-600.222/LG	1190	600	1015	1000	600	34.5	500	200 x 40
sw-700.202/LG	1190	700	1015	1000	700	40.0	500	200 x 40
sw-800.202/LG	1390	800	1015	1200	800	45.5	500	200 x 40

EasySTOP swivel castors and foot guards for your safety!



Three-sided trolley with board, RAL 7035

Article no.	Dimension			Loading surface		Weight kg	Load cap. kg	Wheel diam. mm
	w	mm D	H	w mm	d			
sw-500.302/LG	1040	500	975	850	475	38.0	400	160 x 40
sw-600.302/LG	1190	600	1015	1000	575	45.0	500	200 x 40
sw-700.302/LG	1190	700	1015	1000	675	48.5	500	200 x 40
sw-800.302/LG	1390	800	1015	1200	775	56.0	500	200 x 40

EasySTOP swivel castors and foot guards for your safety!

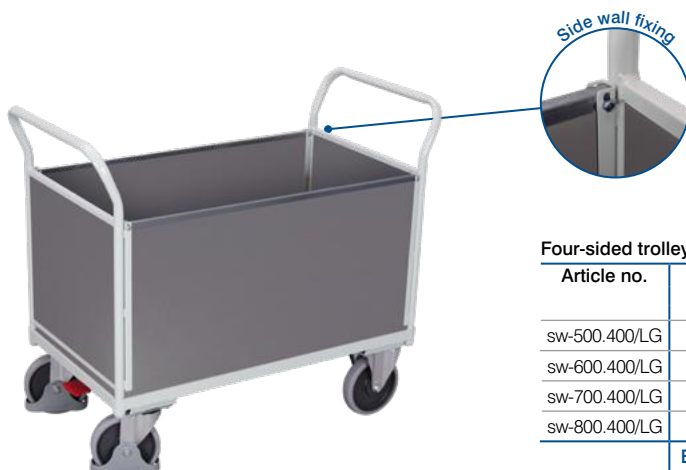

Four-sided trolley with board, RAL 7035

Article no.	Dimension			Loading surface		Weight kg	Load cap. kg	Wheel diam. mm
	w	mm D	H	w mm	d			
sw-500.400/LG	1040	500	975	850	450	43.5	400	160 x 40
sw-600.400/LG	1190	600	1015	1000	550	51.0	500	200 x 40
sw-700.400/LG	1190	700	1015	1000	650	54.0	500	200 x 40
sw-800.400/LG	1390	800	1015	1200	750	61.0	500	200 x 40

EasySTOP swivel castors and foot guards for your safety!



System trolleys with mesh sides

Modular system; Base structure with innovative frame section; Load surface of wood-based board, surface coated in dark grey; End and side walls of mesh with size 50 x 50 mm; Side walls 500 mm high and removable; Trolleys powder-coated RAL 7016 anthracite grey or RAL 7035 light grey; Permanent surface protection; Impact- and scratch-resistant; Grey non-marking thermoplastic rubber tyres on plastic wheel rim with precision deep-groove ball bearings; Thread guard and foot guard; 2 **EasySTOP** swivel castors and 2 fixed castors.



Single-end trolley with mesh, RAL 7016

Article no.	Dimension			Loading surface		Weight kg	Load cap. kg	Wheel diam. mm
	w	mm D	H	w	mm d			
sw-500.101/AG	975	500	975	880	500	25.0	400	160 x 40
sw-600.101/AG	1125	600	1015	1030	600	30.0	500	200 x 40
sw-700.101/AG	1125	700	1015	1030	700	31.5	500	200 x 40
sw-800.101/AG	1325	800	1015	1230	800	36.5	500	200 x 40

EasySTOP swivel castors and foot guards for your safety!



Double-end trolley with mesh, RAL 7016

Article no.	Dimension			Loading surface		Weight kg	Load cap. kg	Wheel diam. mm
	w	mm D	H	w	mm d			
sw-500.201/AG	1040	500	975	850	500	30.5	400	160 x 40
sw-600.201/AG	1190	600	1015	1000	600	36.0	500	200 x 40
sw-700.201/AG	1190	700	1015	1000	700	38.5	500	200 x 40
sw-800.201/AG	1390	800	1015	1200	800	45.0	500	200 x 40

EasySTOP swivel castors and foot guards for your safety!

Three-sided trolley with mesh, RAL 7016

Article no.	Dimension			Loading surface		Weight kg	Load cap. kg	Wheel diam. mm
	w	mm D	H	w	mm d			
sw-500.301/AG	1040	500	975	850	475	32.0	400	160 x 40
sw-600.301/AG	1190	600	1015	1000	575	38.0	500	200 x 40
sw-700.301/AG	1190	700	1015	1000	675	41.5	500	200 x 40
sw-800.301/AG	1390	800	1015	1200	775	47.5	500	200 x 40

EasySTOP swivel castors and foot guards for your safety!



Four-sided trolley with mesh, RAL 7016

Article no.	Dimension			Loading surface		Weight kg	Load cap. kg	Wheel diam. mm
	w	mm D	H	w	mm d			
sw-500.401/AG	1040	500	975	850	450	37.0	400	160 x 40
sw-600.401/AG	1190	600	1015	1000	550	42.5	500	200 x 40
sw-700.401/AG	1190	700	1015	1000	650	45.0	500	200 x 40
sw-800.401/AG	1390	800	1015	1200	750	53.0	500	200 x 40

EasySTOP swivel castors and foot guards for your safety!



System trolleys with mesh sides



Single-end trolley with mesh, RAL 7035

Article no.	Dimension			Loading surface		Weight kg	Load cap. kg	Wheel diam. mm
	W	mm D	H	w mm	d			
sw-500.101/LG	975	500	975	880	500	25.0	400	160 x 40
sw-600.101/LG	1125	600	1015	1030	600	30.0	500	200 x 40
sw-700.101/LG	1125	700	1015	1030	700	31.5	500	200 x 40
sw-800.101/LG	1325	800	1015	1230	800	36.5	500	200 x 40

EasySTOP swivel castors and foot guards for your safety!



Double-end trolley with mesh, RAL 7035

Article no.	Dimension			Loading surface		Weight kg	Load cap. kg	Wheel diam. mm
	W	mm D	H	w mm	d			
sw-500.201/LG	1040	500	975	850	500	30.5	400	160 x 40
sw-600.201/LG	1190	600	1015	1000	600	36.0	500	200 x 40
sw-700.201/LG	1190	700	1015	1000	700	38.5	500	200 x 40
sw-800.201/LG	1390	800	1015	1200	800	45.0	500	200 x 40

EasySTOP swivel castors and foot guards for your safety!



Three-sided trolley with mesh, RAL 7035

Article no.	Dimension			Loading surface		Weight kg	Load cap. kg	Wheel diam. mm
	W	mm D	H	w mm	d			
sw-500.301/LG	1040	500	975	850	475	32.0	400	160 x 40
sw-600.301/LG	1190	600	1015	1000	575	38.0	500	200 x 40
sw-700.301/LG	1190	700	1015	1000	675	41.5	500	200 x 40
sw-800.301/LG	1390	800	1015	1200	775	47.5	500	200 x 40

EasySTOP swivel castors and foot guards for your safety!



Four-sided trolley with mesh, RAL 7035

Article no.	Dimension			Loading surface		Weight kg	Load cap. kg	Wheel diam. mm
	W	mm D	H	w mm	d			
sw-500.401/LG	1040	500	975	850	450	37.0	400	160 x 40
sw-600.401/LG	1190	600	1015	1000	550	42.5	500	200 x 40
sw-700.401/LG	1190	700	1015	1000	650	45.0	500	200 x 40
sw-800.401/LG	1390	800	1015	1200	750	53.0	500	200 x 40

EasySTOP swivel castors and foot guards for your safety!



Box trolleys

Modular system; Base structure with innovative frame section; Load surface of wood-based board, surface coated in dark grey; End and side walls of wood-based board, surface coated in dark grey or of mesh with size 50 x 50 mm; Height of end and side walls: 710 mm; With flap-down half wall on one side; Trolleys powder-coated RAL 7016 anthracite grey or RAL 7035 light grey; Permanent surface protection; Impact- and scratch-resistant; Grey non-marking thermoplastic rubber tyres on plastic wheel rim with precision deepgroove ball bearings; Thread guard and foot guard; 2 **EasySTOP** swivel castors and 2 fixed castors.



Box trolley with board panels, RAL 7016

Article no.	Dimension mm			Loading surface mm		Weight kg	Load cap. kg	Wheel diam. mm
	W	D	H	w	d			
sw-700.406/AG	1060	715	1095	1000	650	73.0	500	200 x 40
sw-800.406/AG	1260	815	1095	1200	750	84.0	500	200 x 40

EasySTOP swivel castors and foot guards for your safety!



Box trolley with mesh, RAL 7016

Article no.	Dimension mm			Loading surface mm		Weight kg	Load cap. kg	Wheel diam. mm
	W	D	H	w	d			
sw-700.404/AG	1060	715	1095	1000	650	50.5	500	200 x 40
sw-800.404/AG	1260	815	1095	1200	750	57.0	500	200 x 40

EasySTOP swivel castors and foot guards for your safety!

Table trolleys

Modular system; Base structure with innovative frame section; Load surfaces of wood-based board, surface coated in dark grey; Load surfaces flush with frame; Upper shelf replaceable; Trolleys powder-coated RAL 7016 anthracite grey or RAL 7035 light grey; Permanent surface protection; Impact- and scratch-resistant; Grey non-marking thermoplastic rubber tyres on plastic wheel rim with precision deepgroove ball bearings; Thread guard and foot guard; 2 **EasySTOP** swivel castors and 2 fixed castors.

Table trolley with 2 load surfaces, RAL 7016

Article no.	Dimension mm			Loading surface mm		Weight kg	Load cap. kg	Wheel diam. mm
	W	D	H	w	d			
sw-500.502/AG	1045	500	935	850	500	30.0	200	125 x 32
sw-600.502/AG	1195	600	935	1000	600	34.0	200	125 x 32

Load capacity shelf: 80 kg*

EasySTOP swivel castors and foot guards for your safety!



520 mm

*Static distributed load; Total load of the transport device must not be exceeded!

Box and table trolleys



Box trolley with board panels, RAL 7035

Article no.	Dimension mm			Loading surface mm		Weight kg	Load cap. kg	Wheel diam. mm
	W	D	H	w	d			
sw-700.406/LG	1060	715	1095	1000	650	73.0	500	200 x 40
sw-800.406/LG	1260	815	1095	1200	750	84.0	500	200 x 40

EasySTOP swivel castors and foot guards for your safety!



Box trolley with mesh, RAL 7035

Article no.	Dimension mm			Loading surface mm		Weight kg	Load cap. kg	Wheel diam. mm
	W	D	H	w	d			
sw-700.404/LG	1060	715	1095	1000	650	50.5	500	200 x 40
sw-800.404/LG	1260	815	1095	1200	750	57.0	500	200 x 40

EasySTOP swivel castors and foot guards for your safety!



520 mm

Table trolley with 2 load surfaces, RAL 7035

Article no.	Dimension mm			Loading surface mm		Weight kg	Load cap. kg	Wheel diam. mm
	W	D	H	w	d			
sw-500.502/LG	1045	500	935	850	500	30.0	200	125 x 32
sw-600.502/LG	1195	600	935	1000	600	34.0	200	125 x 32

Load capacity shelf: 80 kg*

EasySTOP swivel castors and foot guards for your safety!

*Static distributed load; Total load of the transport device must not be exceeded!



Light table trolleys

Modular system; Base structure with innovative frame section; Load surfaces of wood-based board, surface coated in dark grey; Set in angle-steel frame, edge = 15 mm high; Trolleys powder-coated RAL 7016 anthracite grey or RAL 7035 light grey; Permanent surface protection; Impact- and scratch-resistant; Grey non-marking thermoplastic rubber tyres on plastic wheel rim with precision deepgroove ball bearings; Thread guard and foot guard; 2 **EasySTOP** swivel castors and 2 fixed castors.



Table trolley with 2 load surfaces, RAL 7016

Article no.	Dimension			Loading surface		Weight kg	Load cap. kg	Wheel diam. mm
	w	mm D	H	w	d			
sw-500.501/AG	1025	525	850	835	490	28.0	250	125 x 32
sw-600.501/AG	1175	625	850	985	590	33.5	250	125 x 32

Load capacity shelf: 80 kg*
EasySTOP swivel castors and foot guards for your safety!



Table trolley with 3 load surfaces, RAL 7016

Article no.	Dimension			Loading surface		Weight kg	Load cap. kg	Wheel diam. mm
	w	mm D	H	w	d			
sw-500.603/AG	1025	525	850	835	490	37.0	250	125 x 32
sw-600.601/AG	1175	625	850	985	590	44.5	250	125 x 32

Load capacity shelf: 80 kg*
EasySTOP swivel castors and foot guards for your safety!

Table trolley with 2 load surfaces, RAL 7016

Article no.	Dimension			Loading surface		Weight kg	Load cap. kg	Wheel diam. mm
	w	mm D	H	w	d			
sw-500.500/AG	975	525	1010	835	490	28.5	250	125 x 32
sw-600.500/AG	1125	625	1010	985	590	34.0	250	125 x 32

Load capacity shelf: 80 kg*
EasySTOP swivel castors and foot guards for your safety!



Table trolley with 3 load surfaces, RAL 7016

Article no.	Dimension			Loading surface		Weight kg	Load cap. kg	Wheel diam. mm
	w	mm D	H	w	d			
sw-500.600/AG	975	525	1010	835	490	37.5	250	125 x 32
sw-600.600/AG	1125	625	1010	985	590	45.0	250	125 x 32

Load capacity shelf: 80 kg*
EasySTOP swivel castors and foot guards for your safety!



*Static distributed load; Total load of the transport device must not be exceeded!

Light table trolleys



Table trolley with 2 load surfaces, RAL 7035

Article no.	Dimension			Loading surface		Weight kg	Load cap. kg	Wheel diam. mm
	W	D	H	w	d			
sw-500.501/LG	1025	525	850	835	490	28.0	250	125 x 32
sw-600.501/LG	1175	625	850	985	590	33.5	250	125 x 32

Load capacity shelf: 80 kg*
EasySTOP swivel castors and foot guards for your safety!



Table trolley with 3 load surfaces, RAL 7035

Article no.	Dimension			Loading surface		Weight kg	Load cap. kg	Wheel diam. mm
	W	D	H	w	d			
sw-500.603/LG	1025	525	850	835	490	37.0	250	125 x 32
sw-600.601/LG	1175	625	850	985	590	44.5	250	125 x 32

Load capacity shelf: 80 kg*
EasySTOP swivel castors and foot guards for your safety!



Table trolley with 2 load surfaces, RAL 7035

Article no.	Dimension			Loading surface		Weight kg	Load cap. kg	Wheel diam. mm
	W	D	H	w	d			
sw-500.500/LG	975	525	1010	835	490	28.5	250	125 x 32
sw-600.500/LG	1125	625	1010	985	590	34.0	250	125 x 32

Load capacity shelf: 80 kg*
EasySTOP swivel castors and foot guards for your safety!



Table trolley with 3 load surfaces, RAL 7035

Article no.	Dimension			Loading surface		Weight kg	Load cap. kg	Wheel diam. mm
	W	D	H	w	d			
sw-500.600/LG	975	525	1010	835	490	37.5	250	125 x 32
sw-600.600/LG	1125	625	1010	985	590	45.0	250	125 x 32

Load capacity shelf: 80 kg*
EasySTOP swivel castors and foot guards for your safety!

*Static distributed load; Total load of the transport device must not be exceeded!



Heavy-duty table trolleys and table trolleys with pan

Heavy-duty table trolleys of modular system; Base structure with innovative frame section; Load surfaces of wood-based board, surface coated in dark grey; Load surfaces flush with the frame; Table trolleys with pan of welded steel construction; Screwed; Oil-tight pans and edge = 40 mm high; Trolleys powder-coated RAL 7016 anthracite grey or RAL 7035 light grey; Permanent surface protection; Impact- and scratch-resistant; Grey non-marking thermoplastic rubber tyres on plastic wheel rim with precision deepgroove ball bearings; Thread guard and foot guard; 2 **EasySTOP** swivel castors and 2 fixed castors.



Heavy-duty table trolley with 2 load surfaces, RAL 7016

Article no.	Dimension			Loading surface		Weight kg	Load cap. kg	Wheel diam. mm
	W	mm D	H	w	d			
sw-500.504/AG	1040	500	880	850	500	34.0	400	160 x 40
sw-600.510/AG	1190	600	920	1000	600	40.5	500	200 x 40
sw-700.500/AG	1190	700	920	1000	700	46.0	500	200 x 40
sw-800.500/AG	1390	800	920	1200	800	51.5	500	200 x 40

Load capacity shelf: 200 kg*
EasySTOP swivel castors and foot guards for your safety!



Heavy-duty table trolley with 3 load surfaces, RAL 7016

Article no.	Dimension			Loading surface		Weight kg	Load cap. kg	Wheel diam. mm
	W	mm D	H	w	d			
sw-500.650/AG	1040	500	880	850	500	44.5	400	160 x 40
sw-600.512/AG	1190	600	920	1000	600	54.5	500	200 x 40
sw-700.600/AG	1190	700	920	1000	700	55.5	500	200 x 40
sw-800.600/AG	1390	800	920	1200	800	67.5	500	200 x 40

Load capacity shelf: 200 kg*
EasySTOP swivel castors and foot guards for your safety!

Table trolley with 2 load surfaces, RAL 7016

Article no.	Dimension			Loading surface		Weight kg	Load cap. kg	Wheel diam. mm
	W	mm D	H	w	d			
sw-500.510/AG	985	500	910	845	495	36.5	400	160 x 40
sw-700.510/AG	1135	700	950	995	695	50.0	400	200 x 40

Load capacity shelf: 100 kg*
EasySTOP swivel castors and foot guards for your safety!



Table trolley with 3 load surfaces, RAL 7016

Article no.	Dimension			Loading surface		Weight kg	Load cap. kg	Wheel diam. mm
	W	mm D	H	w	d			
sw-500.610/AG	985	500	910	845	495	44.5	400	160 x 40
sw-700.610/AG	1135	700	950	995	695	63.0	400	200 x 40

Load capacity shelf: 100 kg*
EasySTOP swivel castors and foot guards for your safety!



*Static distributed load; Total load of the transport device must not be exceeded!

Heavy-duty table trolleys and table trolleys with pan



Heavy-duty table trolley with 2 load surfaces, RAL 7035

Article no.	Dimension			Loading surface		Weight kg	Load cap. kg	Wheel diam. mm
	W	mm D	H	w	mm d			
sw-500.504/LG	1040	500	880	850	500	34.0	400	160 x 40
sw-600.510/LG	1190	600	920	1000	600	40.5	500	200 x 40
sw-700.500/LG	1190	700	920	1000	700	46.0	500	200 x 40
sw-800.500/LG	1390	800	920	1200	800	51.5	500	200 x 40

Load capacity shelf: 200 kg*
EasySTOP swivel castors and foot guards for your safety!



Heavy-duty table trolley with 3 load surfaces, RAL 7035

Article no.	Dimension			Loading surface		Weight kg	Load cap. kg	Wheel diam. mm
	W	mm D	H	w	mm d			
sw-500.650/LG	1040	500	880	850	500	44.5	400	160 x 40
sw-600.512/LG	1190	600	920	1000	600	54.5	500	200 x 40
sw-700.600/LG	1190	700	920	1000	700	55.5	500	200 x 40
sw-800.600/LG	1390	800	920	1200	800	67.5	500	200 x 40

Load capacity shelf: 200 kg*
EasySTOP swivel castors and foot guards for your safety!



Table trolley with 2 load surfaces, RAL 7035

Article no.	Dimension			Loading surface		Weight kg	Load cap. kg	Wheel diam. mm
	W	mm D	H	w	mm d			
sw-500.510/LG	985	500	910	845	495	36.5	400	160 x 40
sw-700.510/LG	1135	700	950	995	695	50.0	400	200 x 40

Load capacity shelf: 100 kg*
EasySTOP swivel castors and foot guards for your safety!



Table trolley with 3 load surfaces, RAL 7035

Article no.	Dimension			Loading surface		Weight kg	Load cap. kg	Wheel diam. mm
	W	mm D	H	w	mm d			
sw-500.610/LG	985	500	910	845	495	44.5	400	160 x 40
sw-700.610/LG	1135	700	950	995	695	63.0	400	200 x 40

Load capacity shelf: 100 kg*
EasySTOP swivel castors and foot guards for your safety!

*Static distributed load; Total load of the transport device must not be exceeded!

Easy
STOP

Workshop trolleys

Welded steel construction; Base structure with innovative frame section; Load surfaces of wood-based board, surface coated in dark grey; Set in angle-steel frame, edge = 15 mm high; Cupboards with 1 fixed and 1 or 2 variable cupboard shelves; Carrying capacity 30 kg per cupboard shelf; Workshop trolley with double door and T-handle lock; Trolleys powder-coated RAL 7016 anthracite grey or RAL 7035 light grey; Permanent surface protection; Impact- and scratch-resistant; Grey non-marking thermoplastic rubber tyres on plastic wheel rim with precision deepgroove ball bearings; Thread guard and foot guard; 2 **EasySTOP** swivel castors and 2 fixed castors.



Inside dimensions cupboard:
W=470 x D=575 x H=575 mm (1x)

Workshop trolley with 3 load surfaces, RAL 7016

Article no.	Dimension mm			Loading surface mm		Weight kg	Load cap. kg	Wheel diam. mm
	W	D	H	w	d			
sw-600.603/AG	1125	625	1010	985	590	62.5	250	125 x 32

Load capacity shelf: 80 kg*
EasySTOP swivel castors and foot guards for your safety!



Inside dimensions cupboard:
W=470 x D=575 x H=575 mm (2x)

Workshop trolley with 1 load surface, RAL 7016

Article no.	Dimension mm			Loading surface mm		Weight kg	Load cap. kg	Wheel diam. mm
	W	D	H	w	d			
sw-600.604/AG	1125	625	1010	985	590	76.0	250	125 x 32

Load capacity shelf: 80 kg*
EasySTOP swivel castors and foot guards for your safety!

Inside dimensions cupboard:
W=890 x D=575 x H=575 mm (1x)

Workshop trolley with 1 load surface, RAL 7016

Article no.	Dimension mm			Loading surface mm		Weight kg	Load cap. kg	Wheel diam. mm
	W	D	H	w	d			
sw-600.640/AG	1125	625	1010	985	590	67.5	250	125 x 32

Load capacity shelf: 80 kg*
EasySTOP swivel castors and foot guards for your safety!



*Static distributed load; Total load of the transport device must not be exceeded!

Workshop trolleys



Inside dimensions cupboard:
W=470 x D=575 x H=575 mm (1x)

Workshop trolley with 3 load surfaces, RAL 7035

Article no.	Dimension			Loading surface		Weight	Load cap.	Wheel diam.
	W	D	H	w	d			
sw-600.603/LG	1125	625	1010	985	590	62.5	250	125 x 32

Load capacity shelf: 80 kg*
EasySTOP swivel castors and foot guards for your safety!



Inside dimensions cupboard:
W=470 x D=575 x H=575 mm (2x)

Workshop trolley with 1 load surface, RAL 7035

Article no.	Dimension			Loading surface		Weight	Load cap.	Wheel diam.
	W	D	H	w	d			
sw-600.604/LG	1125	625	1010	985	590	76.0	250	125 x 32

Load capacity shelf: 80 kg*
EasySTOP swivel castors and foot guards for your safety!



Inside dimensions cupboard:
W=890 x D=575 x H=575 mm (1x)

Workshop trolley with 1 load surface, RAL 7035

Article no.	Dimension			Loading surface		Weight	Load cap.	Wheel diam.
	W	D	H	w	d			
sw-600.640/LG	1125	625	1010	985	590	67.5	250	125 x 32

Load capacity shelf: 80 kg*
EasySTOP swivel castors and foot guards for your safety!

*Static distributed load; Total load of the transport device must not be exceeded!



Workshop trolleys

Welded steel construction; Base structure with innovative frame section; Load surfaces of wood-based board, surface coated in dark grey; Set in angle-steel frame, edge = 15 mm high; Cupboards with 1 fixed and 1 or 2 variable cupboard shelves; Carrying capacity 30 kg per cupboard shelf; Drawers with sliding runners; Cylinder lock (simultaneous locking); Carrying capacity 25 kg per drawer; Trolleys powder-coated RAL 7016 anthracite grey or RAL 7035 light grey; Permanent surface protection; Impact- and scratch-resistant; Grey non-marking thermoplastic rubber tyres on plastic wheel rim with precision deepgroove ball bearings; Thread guard and foot guard; 2 **EasySTOP** swivel castors and 2 fixed castors.



Inside dimensions drawer:
B=390 x T=535 x H=95 mm (3x)
B=390 x T=535 x H=155 mm (1x)

Suitable drawer divider set
(zsw-600.604) on page 114

Workshop trolley with 3 load surfaces, RAL 7016

Article no.	Dimension			Loading surface		Weight kg	Load cap. kg	Wheel diam. mm
	W	D	H	w	d			
sw-600.605/AG	1125	625	1010	985	590	80.5	250	125 x 32

Load capacity shelf: 80 kg*
EasySTOP swivel castors and foot guards for your safety!



Inside dimensions cupboard:
W=470 x D=575 x H=575 mm (1x)
Inside dimensions drawer:
W=390 x D=535 x H=95 mm (3x)
W=390 x D=535 x H=155 mm (1x)

Suitable drawer divider set
(zsw-600.604) on page 114

Workshop trolley with 1 load surface, RAL 7016

Article no.	Dimension			Loading surface		Weight kg	Load cap. kg	Wheel diam. mm
	W	D	H	w	d			
sw-600.606/AG	1125	625	1010	985	590	94.5	250	125 x 32

Load capacity shelf: 80 kg*
EasySTOP swivel castors and foot guards for your safety!

Inside dimensions drawer:
B=390 x T=535 x H=95 mm (6x)
B=390 x T=535 x H=155 mm (2x)

Suitable drawer divider set
(zsw-600.604) on page 114

Workshop trolley with 1 load surface, RAL 7016

Article no.	Dimension			Loading surface		Weight kg	Load cap. kg	Wheel diam. mm
	W	D	H	w	d			
sw-600.608/AG	1125	625	1010	985	590	112.0	250	125 x 32

Load capacity shelf: 80 kg*
EasySTOP swivel castors and foot guards for your safety!



*Static distributed load; Total load of the transport device must not be exceeded!

Workshop trolleys



Suitable drawer divider set
(zsw-600.604) on page 114

Inside dimensions drawer:
B=390 x T=535 x H=95 mm (3x)
B=390 x T=535 x H=155 mm (1x)

Workshop trolley with 3 load surfaces, RAL 7035

Article no.	Dimension			Loading surface		Weight	Load cap.	Wheel diam.
	W	D	H	w	d			
sw-600.605/LG	1125	625	1010	985	590	80.5	250	125 x 32

Load capacity shelf: 80 kg*
EasySTOP swivel castors and foot guards for your safety!

Suitable drawer divider set
(zsw-600.604) on page 114

Inside dimensions cupboard:
W=470 x D=575 x H=575 mm (1x)
Inside dimensions drawer:
W=390 x D=535 x H=95 mm (3x)
W=390 x D=535 x H=155 mm (1x)



Workshop trolley with 1 load surface, RAL 7035

Article no.	Dimension			Loading surface		Weight	Load cap.	Wheel diam.
	W	D	H	w	d			
sw-600.606/LG	1125	625	1010	985	590	94.5	250	125 x 32

Load capacity shelf: 80 kg*
EasySTOP swivel castors and foot guards for your safety!



Suitable drawer divider set
(zsw-600.604) on page 114

Inside dimensions drawer:
B=390 x T=535 x H=95 mm (6x)
B=390 x T=535 x H=155 mm (2x)

Workshop trolley with 1 load surface, RAL 7035

Article no.	Dimension			Loading surface		Weight	Load cap.	Wheel diam.
	W	D	H	w	d			
sw-600.608/LG	1125	625	1010	985	590	112.0	250	125 x 32

Load capacity shelf: 80 kg*
EasySTOP swivel castors and foot guards for your safety!

*Static distributed load; Total load of the transport device must not be exceeded!



Parcel trolleys

Modular system; Base structure with innovative frame section; Screwed tubular push bar; 2 screwed connecting tubes; Load surface of wood-based board, surface coated in dark grey; Optional removable shelves for insertion at 120 mm intervals; Mesh sides and ends, mesh size 120 x 120 mm; Side walls replaceable and variable removable; Trolleys powder-coated RAL 7016 anthracite grey or RAL 7035 light grey; Permanent surface protection; Impact- and scratch-resistant; Grey non-marking thermoplastic rubber tyres on plastic wheel rim with precision deepgroove ball bearings; Thread guard and foot guard; 2 **EasySTOP** swivel castors and 2 fixed castors.



Three-sided parcel trolley, high, RAL 7016

Article no.	Dimension			Loading surface		Weight kg	Load cap. kg	Wheel diam. mm
	W	mm D	H	w	d			
sw-500.306/AG	1040	525	1780	850	500	43.0	400	160 x 40
sw-600.306/AG	1190	625	1820	1000	600	52.0	500	200 x 40
sw-700.306/AG	1190	725	1820	1000	700	60.5	500	200 x 40
sw-800.306/AG	1390	825	1820	1200	800	68.5	500	200 x 40

EasySTOP swivel castors and foot guards for your safety!



Four-sided parcel trolley, high, RAL 7016

Article no.	Dimension			Loading surface		Weight kg	Load cap. kg	Wheel diam. mm
	W	mm D	H	w	d			
sw-500.405/AG	1040	540	1780	850	500	49.0	400	160 x 40
sw-600.405/AG	1190	640	1820	1000	600	57.5	500	200 x 40
sw-700.403/AG	1190	740	1820	1000	700	68.0	500	200 x 40
sw-800.403/AG	1390	840	1820	1200	800	76.0	500	200 x 40

EasySTOP swivel castors and foot guards for your safety!

Parcel trolleys



Three-sided parcel trolley, high, RAL 7035

Article no.	Dimension			Loading surface		Weight kg	Load cap. kg	Wheel diam. mm
	W	mm D	H	w	d			
sw-500.306/LG	1040	525	1780	850	500	43.0	400	160 x 40
sw-600.306/LG	1190	625	1820	1000	600	52.0	500	200 x 40
sw-700.306/LG	1190	725	1820	1000	700	60.5	500	200 x 40
sw-800.306/LG	1390	825	1820	1200	800	68.5	500	200 x 40

EasySTOP swivel castors and foot guards for your safety!



Side wall fixing

Four-sided parcel trolley, high, RAL 7035

Article no.	Dimension			Loading surface		Weight kg	Load cap. kg	Wheel diam. mm
	W	mm D	H	w	d			
sw-500.405/LG	1040	540	1780	850	500	49.0	400	160 x 40
sw-600.405/LG	1190	640	1820	1000	600	57.5	500	200 x 40
sw-700.403/LG	1190	740	1820	1000	700	68.0	500	200 x 40
sw-800.403/LG	1390	840	1820	1200	800	76.0	500	200 x 40

EasySTOP swivel castors and foot guards for your safety!



Additional articles - Shelves for parcel/shelf trolleys, RAL 7016/7035

Article no.	Dimension		for loading surface		Weight kg	Load cap. kg	
	W	D	w	d			
zsw-500.218/G	835	470	850	500	8.0	80	Additional shelf incl. angle support
zsw-600.218/G	985	570	1000	600	10.0	80	
zsw-700.218/G	985	670	1000	700	12.0	80	
zsw-800.218/G	1185	770	1200	800	16.0	80	





Shelf trolleys

Modular system; Base structure with innovative frame section; Screwed tubular push bar; 2 screwed connecting tubes; Load surface and shelves of wood-based board, surface coated in dark grey; Optional removable shelves for insertion at 120 mm; Mesh ends, mesh size 120 x 120 mm; Trolleys powder-coated RAL 7016 anthracite grey or RAL 7035 light grey; Permanent surface protection; Impact- and scratch-resistant; Grey non-marking thermoplastic rubber tyres on plastic wheel rim with precision deepgroove ball bearings; Thread guard and foot guard; 2 **EasySTOP** swivel castors and 2 fixed castors.



Shelf trolley, high, RAL 7016

Article no.	Dimension mm			Loading surface mm		Weight kg	Load cap. kg	Wheel diam. mm
	W	D	H	w	d			
sw-500.236/AG	1035	520	1780	850	500	64.0	400	160 x 40
sw-600.236/AG	1185	620	1820	1000	600	81.0	500	200 x 40
sw-700.216/AG	1185	720	1820	1000	700	84.0	500	200 x 40
sw-800.216/AG	1385	820	1820	1200	800	102.5	500	200 x 40

Load capacity shelf: 80 kg*

EasySTOP swivel castors and foot guards for your safety!



Shelf trolley, high, RAL 7016

Article no.	Dimension mm			Loading surface mm		Weight kg	Load cap. kg	Wheel diam. mm
	W	D	H	w	d			
sw-500.237/AG	1035	520	1780	850	500	70.0	400	160 x 40
sw-600.237/AG	1185	620	1820	1000	600	87.5	500	200 x 40
sw-700.217/AG	1185	720	1820	1000	700	95.5	500	200 x 40
sw-800.217/AG	1385	820	1820	1200	800	116.0	500	200 x 40

Load capacity shelf: 80 kg*

EasySTOP swivel castors and foot guards for your safety!

*Static distributed load; Total load of the transport device must not be exceeded!

Shelf trolleys



Shelf trolley, high, RAL 7035

Article no.	Dimension			Loading surface		Weight kg	Load cap. kg	Wheel diam. mm
	w	mm D	H	w mm	d			
sw-500.236/LG	1035	520	1780	850	500	64.0	400	160 x 40
sw-600.236/LG	1185	620	1820	1000	600	81.0	500	200 x 40
sw-700.216/LG	1185	720	1820	1000	700	84.0	500	200 x 40
sw-800.216/LG	1385	820	1820	1200	800	102.5	500	200 x 40

Load capacity shelf: 80 kg*
EasySTOP swivel castors and foot guards for your safety!



Shelf trolley, high, RAL 7035

Article no.	Dimension			Loading surface		Weight kg	Load cap. kg	Wheel diam. mm
	w	mm D	H	w mm	d			
sw-500.237/LG	1035	520	1780	850	500	70.0	400	160 x 40
sw-600.237/LG	1185	620	1820	1000	600	87.5	500	200 x 40
sw-700.217/LG	1185	720	1820	1000	700	95.5	500	200 x 40
sw-800.217/LG	1385	820	1820	1200	800	116.0	500	200 x 40

Load capacity shelf: 80 kg*
EasySTOP swivel castors and foot guards for your safety!



Additional articles - Shelves for parcel/shelf trolleys, RAL 7016/7035

Article no.	Dimension		for loading surface		Weight kg	Load cap. kg	Additional shelf incl. angle support
	w mm	D mm	w mm	d mm			
zsw-500.218/G	835	470	850	500	8.0	80	
zsw-600.218/G	985	570	1000	600	10.0	80	
zsw-700.218/G	985	670	1000	700	12.0	80	
zsw-800.218/G	1185	770	1200	800	16.0	80	

*Static distributed load; Total load of the transport device must not be exceeded!



Shelf trolleys

Modular system; Base structure with innovative frame section; Screwed tubular push bar; 2 screwed connecting tubes; Load surface and shelves of wood-based board, surface coated in dark grey; Optional removable shelves for insertion at 120 mm; Mesh sides and ends, mesh size 120 x 120 mm; Side walls replaceable and variable removable; Trolleys powder-coated RAL 7016 anthracite grey or RAL 7035 light grey; Permanent surface protection; Impact- and scratch-resistant; Grey non-marking thermoplastic rubber tyres on plastic wheel rim with precision deepgroove ball bearings; Thread guard and foot guard; 2 **EasySTOP** swivel castors and 2 fixed castors.



Shelf trolley, high, RAL 7016

Article no.	Dimension mm			Loading surface mm		Weight kg	Load cap. kg	Wheel diam. mm
	W	D	H	w	d			
sw-500.304/AG	1040	525	1780	850	500	73.5	400	160 x 40
sw-600.304/AG	1190	625	1820	1000	600	86.5	500	200 x 40
sw-700.304/AG	1190	725	1820	1000	700	91.0	500	200 x 40
sw-800.304/AG	1390	825	1820	1200	800	103.0	500	200 x 40

Load capacity shelf: 80 kg*
EasySTOP swivel castors and foot guards for your safety!



Shelf trolley, high, RAL 7016

Article no.	Dimension mm			Loading surface mm		Weight kg	Load cap. kg	Wheel diam. mm
	W	D	H	w	d			
sw-500.311/AG	1040	540	1780	850	500	83.5	400	160 x 40
sw-600.311/AG	1190	640	1820	1000	600	96.5	500	200 x 40
sw-700.311/AG	1190	740	1820	1000	700	101.0	500	200 x 40
sw-800.311/AG	1390	840	1820	1200	800	113.0	500	200 x 40

Load capacity shelf: 80 kg*
EasySTOP swivel castors and foot guards for your safety!

Shelf trolley, high, RAL 7016

Article no.	Dimension mm			Loading surface mm		Weight kg	Load cap. kg	Wheel diam. mm
	W	D	H	w	d			
sw-500.305/AG	1040	525	1780	850	500	78.5	400	160 x 40
sw-600.305/AG	1190	625	1820	1000	600	91.5	500	200 x 40
sw-700.305/AG	1190	725	1820	1000	700	96.0	500	200 x 40
sw-800.305/AG	1390	825	1820	1200	800	108.0	500	200 x 40

Load capacity shelf: 80 kg*
EasySTOP swivel castors and foot guards for your safety!



*Static distributed load; Total load of the transport device must not be exceeded!

Shelf trolleys



Shelf trolley, high, RAL 7035

Article no.	Dimension			Loading surface		Weight	Load cap.	Wheel diam.
	W	D	H	w	d			
sw-500.304/LG	1040	525	1780	850	500	73.5	400	160 x 40
sw-600.304/LG	1190	625	1820	1000	600	86.5	500	200 x 40
sw-700.304/LG	1190	725	1820	1000	700	91.0	500	200 x 40
sw-800.304/LG	1390	825	1820	1200	800	103.0	500	200 x 40

Load capacity shelf: 80 kg*
EasySTOP swivel castors and foot guards for your safety!



Shelf trolley, high, RAL 7035

Article no.	Dimension			Loading surface		Weight	Load cap.	Wheel diam.
	W	D	H	w	d			
sw-500.311/LG	1040	540	1780	850	500	83.5	400	160 x 40
sw-600.311/LG	1190	640	1820	1000	600	96.5	500	200 x 40
sw-700.311/LG	1190	740	1820	1000	700	101.0	500	200 x 40
sw-800.311/LG	1390	840	1820	1200	800	113.0	500	200 x 40

Load capacity shelf: 80 kg*
EasySTOP swivel castors and foot guards for your safety!



Shelf trolley, high, RAL 7035

Article no.	Dimension			Loading surface		Weight	Load cap.	Wheel diam.
	W	D	H	w	d			
sw-500.305/LG	1040	525	1780	850	500	78.5	400	160 x 40
sw-600.305/LG	1190	625	1820	1000	600	91.5	500	200 x 40
sw-700.305/LG	1190	725	1820	1000	700	96.0	500	200 x 40
sw-800.305/LG	1390	825	1820	1200	800	108.0	500	200 x 40

Load capacity shelf: 80 kg*
EasySTOP swivel castors and foot guards for your safety!



Additional articles - Shelves for parcel/shelf trolleys, RAL 7016/7035

Article no.	Dimension		for loading surface		Weight	Load cap.	
	W	D	w	d			
zsw-500.218/G	835	470	850	500	8.0	80	Additional shelf incl. angle support
zsw-600.218/G	985	570	1000	600	10.0	80	
zsw-700.218/G	985	670	1000	700	12.0	80	
zsw-800.218/G	1185	770	1200	800	16.0	80	

*Static distributed load; Total load of the transport device must not be exceeded!



VARIOFIT®



Shelf trolleys fixed welded

Fixed welded angle-steel construction; With or without double wing door; Trolleys with double wing doors have espagnolette bolt lock with T-handle; Double wing door with cylinder lock, incl. 2 keys (different locking); Push/pull bar and double wing door are flush with the frame when not in use; Push/pull bar with soft plastic grip cover black; End and side walls, roof and doors with mesh sides 50 x 50 mm; Load surface and shelves of wood-based board, surface coated in dark grey; Shelf supports for variable insertion at 50 mm intervals; Trolleys powder-coated RAL 7016 anthracite grey or RAL 7035 light grey; Permanent surface protection; Impact- and scratch-resistant; Grey non-marking thermoplastic rubber tyres on plastic wheel rim with precision deepgroove ball bearings; Thread guard and foot guard; 2 **EasySTOP** swivel castors and 2 fixed castors.



The push/pull bar is flush with the frame when not in use.

Shelf trolley fixed welded, RAL 7016

Article no.	Dimension			Loading surface		Weight kg	Load cap. kg	Wheel diam. mm
	W	D	H	w	d			
sw-700.410/AG	1115	730	1810	1045	685	103.5	500	200 x 40
sw-800.410/AG	1315	830	1810	1245	785	120.5	500	200 x 40

Load capacity shelf: 80 kg*
EasySTOP swivel castors and foot guards for your safety!

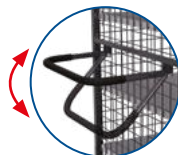

The push/pull bar adjusts to the height of the person pulling when the trolley is being pulled.



Shelf trolley fixed welded, RAL 7016

Article no.	Dimension			Loading surface		Weight kg	Load cap. kg	Wheel diam. mm
	W	D	H	w	d			
sw-700.987/AG	1115	730	1810	1045	685	117.5	500	200 x 40
sw-800.987/AG	1315	830	1810	1245	785	140.0	500	200 x 40

Load capacity shelf: 80 kg*
EasySTOP swivel castors and foot guards for your safety!

*Static distributed load; Total load of the transport device must not be exceeded!

Shelf trolleys fixed welded



The push/pull bar rests on the cross tube when pushing. This ensures that pushing is safe and comfortable.

Shelf trolley fixed welded, RAL 7035

Article no.	Dimension			Loading surface		Weight kg	Load cap. kg	Wheel diam. mm
	w	D	H	w	d			
sw-700.410/LG	1115	730	1810	1045	685	103.5	500	200 x 40
sw-800.410/LG	1315	830	1810	1245	785	120.5	500	200 x 40

Load capacity shelf: 80 kg*
EasySTOP swivel castors and foot guards for your safety!



The double wing door opens 270° and is flush with the frame.

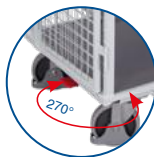

Shelf trolley fixed welded, RAL 7035

Article no.	Dimension			Loading surface		Weight kg	Load cap. kg	Wheel diam. mm
	w	D	H	w	d			
sw-700.987/LG	1115	730	1810	1045	685	117.5	500	200 x 40
sw-800.987/LG	1315	830	1810	1245	785	140.0	500	200 x 40

Load capacity shelf: 80 kg*
EasySTOP swivel castors and foot guards for your safety!



Additional articles - Shelves of wood-based board for shelf trolleys, RAL 7016/7035

Article no.	Dimension		for loading surface		Weight kg	Load cap. kg	Additional shelf
	w	D	w	d			
zsw-700.411/G	1030	660	1045	685	11.5	80	
zsw-800.411/G	1230	760	1245	785	16.0	80	

*Static distributed load; Total load of the transport device must not be exceeded!



Shelf trolleys fixed welded

Fixed welded angle-steel construction; With or without double wing door; Trolleys with double wing doors have espagnolette bolt lock with T-handle; Double wing door with cylinder lock, incl. 2 keys (different locking); Push/pull bar and double wing door are flush with the frame when not in use; Push/pull bar with soft plastic grip cover black; End and side walls, roof and doors of galvanised steel sheet; Load surface and shelves of wood-based board, surface coated in dark grey; Shelf supports for variable insertion at 100 mm intervals; Steel sheets powder-coated RAL 7016 anthracite grey or RAL 7035 light grey; Permanent surface protection; Impact- and scratch-resistant; Grey non-marking thermoplastic rubber tyres on plastic wheel rim with precision deepgroove ball bearings; Thread guard and foot guard; 2 **EasySTOP** swivel castors and 2 fixed castors.

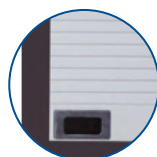

Roller shutter door on request

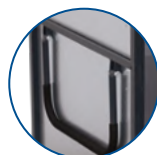

The push/pull bar is flush with the frame when not in use.

Shelf trolley fixed welded, RAL 7016

Article no.	Dimension mm			Loading surface		Weight kg	Load cap. kg	Wheel diam. mm
	w	D	H	w	d			
sw-700.412/AG	1115	730	1810	1045	685	123.0	500	200 x 40
sw-800.412/AG	1315	830	1810	1245	785	153.0	500	200 x 40

Load capacity shelf: 80 kg*

EasySTOP swivel castors and foot guards for your safety!



The double wing door opens 270° and is flush with the frame.

Shelf trolley fixed welded, RAL 7016

Article no.	Dimension mm			Loading surface		Weight kg	Load cap. kg	Wheel diam. mm
	w	D	H	w	d			
sw-700.988/AG	1115	730	1810	1045	685	138.0	500	200 x 40
sw-800.988/AG	1315	830	1810	1245	785	171.5	500	200 x 40

Load capacity shelf: 80 kg*

EasySTOP swivel castors and foot guards for your safety!

*Static distributed load; Total load of the transport device must not be exceeded!



Shelf trolleys fixed welded



The push/pull bar rests on the cross tube when pushing. This ensures that pushing is safe and comfortable.

Shelf trolley fixed welded, RAL 7035

Article no.	Dimension			Loading surface		Weight kg	Load cap. kg	Wheel diam. mm
	w	mm D	H	w	mm d			
sw-700.412/LG	1115	730	1810	1045	685	123.0	500	200 x 40
sw-800.412/LG	1315	830	1810	1245	785	153.0	500	200 x 40

Load capacity shelf: 80 kg*

EasySTOP swivel castors and foot guards for your safety!



The push/pull bar adjusts to the height of the person pulling when the trolley is being pulled.

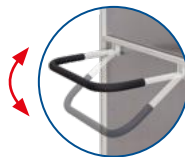

Shelf trolley fixed welded, RAL 7035

Article no.	Dimension			Loading surface		Weight kg	Load cap. kg	Wheel diam. mm
	w	mm D	H	w	mm d			
sw-700.988/LG	1115	730	1810	1045	685	138.0	500	200 x 40
sw-800.988/LG	1315	830	1810	1245	785	171.5	500	200 x 40

Load capacity shelf: 80 kg*

EasySTOP swivel castors and foot guards for your safety!



Additional articles - Shelves of wood-based board for shelf trolleys, RAL 7016/7035

Article no.	Dimension		for loading surface		Weight kg	Load cap. kg	
	w	mm D	w	mm d			
zsw-700.413/G	1000	660	1045	685	10.5	80	Additional shelf
zsw-800.413/G	1200	760	1245	785	14.0	80	

*Static distributed load; Total load of the transport device must not be exceeded!

colours.

Shelf trolleys with sloping shelves

Modular system; Base structure with innovative frame section; Load surface and variable shelves of wood-based board, surface coated in dark grey; For sloping or horizontal insertion; Shelf support interval 120 mm, gradient when sloping 15 degrees; Edge 15 mm high; Tubular push bar welded to one end; Trolleys powder-coated RAL 7016 anthracite grey or RAL 7035 light grey; Permanent surface protection; Impact- and scratch-resistant; Grey non-marking thermoplastic rubber tyres on plastic wheel rim with precision deepgroove ball bearings; Thread guard and foot guard; 2 **EasySTOP** swivel castors and 2 fixed castors.



Shelf trolley with 2 wooden shelves, RAL 7016

Article no.	Dimension			Loading surface		Weight kg	Load cap. kg	Wheel diam. mm
	W	mm D	H	w	mm d			
sw-540.200/AG	1510	550	1235	1355	550	56.0	250	160 x 40
sw-640.200/AG	1805	650	1275	1650	650	64.5	400	200 x 40

Load capacity shelf: 80 kg*
EasySTOP swivel castors and foot guards for your safety!



Shelf trolley with 3 wooden shelves, RAL 7016

Article no.	Dimension			Loading surface		Weight kg	Load cap. kg	Wheel diam. mm
	W	mm D	H	w	mm d			
sw-540.201/AG	1510	550	1535	1355	550	72.0	250	160 x 40
sw-640.201/AG	1805	650	1575	1650	650	87.0	400	200 x 40

Load capacity shelf: 80 kg*
EasySTOP swivel castors and foot guards for your safety!

Non-slip covering for suitable shelf trolleys on request



Shelf trolley with 4 wooden shelves, RAL 7016

Article no.	Dimension			Loading surface		Weight kg	Load cap. kg	Wheel diam. mm
	W	mm D	H	w	mm d			
sw-540.202/AG	1510	550	1815	1355	550	87.0	250	160 x 40
sw-640.202/AG	1805	650	1855	1650	650	101.5	400	200 x 40

Load capacity shelf: 80 kg*
EasySTOP swivel castors and foot guards for your safety!



Additional articles - Wooden shelves for shelf trolley, RAL 7016

Article no.	Dimension		for loading surface		Weight kg	Load cap. kg	
	W	mm D	w	mm d			
zsw-540.202/AG	1320	535	1355	550	12.5	80	Additional shelf
zsw-640.202/AG	1615	635	1650	650	16.0	80	



*Static distributed load; Total load of the transport device must not be exceeded!



Shelf trolleys with sloping shelves

Non-slip covering for suitable shelf trolleys on request

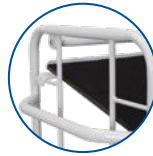

Shelf trolley with 2 wooden shelves, RAL 7035

Article no.	Dimension			Loading surface		Weight kg	Load cap. kg	Wheel diam. mm
	w	mm D	H	w	mm d			
sw-540.200/LG	1510	550	1235	1355	550	56.0	250	160 x 40
sw-640.200/LG	1805	650	1275	1650	650	64.5	400	200 x 40

Load capacity shelf: 80 kg*
EasySTOP swivel castors and foot guards for your safety!

Shelf trolley with 3 wooden shelves, RAL 7035

Article no.	Dimension			Loading surface		Weight kg	Load cap. kg	Wheel diam. mm
	w	mm D	H	w	mm d			
sw-540.201/LG	1510	550	1535	1355	550	72.0	250	160 x 40
sw-640.201/LG	1805	650	1575	1650	650	87.0	400	200 x 40

Load capacity shelf: 80 kg*
EasySTOP swivel castors and foot guards for your safety!

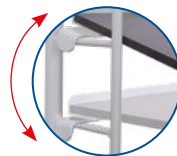

Shelves for insertion diagonally or horizontal

Shelf trolley with 4 wooden shelves, RAL 7035

Article no.	Dimension			Loading surface		Weight kg	Load cap. kg	Wheel diam. mm
	w	mm D	H	w	mm d			
sw-540.202/LG	1510	550	1815	1355	550	87.0	250	160 x 40
sw-640.202/LG	1805	650	1855	1650	650	101.5	400	200 x 40

Load capacity shelf: 80 kg*
EasySTOP swivel castors and foot guards for your safety!

Additional articles - Wooden shelves for shelf trolley, RAL 7035

Article no.	Dimension		for loading surface		Weight kg	Load cap. kg	Additional shelf
	w	mm D	w	mm d			
zsw-540.202/LG	1320	535	1355	550	12.5	80	
zsw-640.202/LG	1615	635	1650	650	16.0	80	

*Static distributed load; Total load of the transport device must not be exceeded!



VARIOfit®

Shelf trolleys with sloping shelves

Modular system; Base structure with innovative frame section; Load surface and variable shelves of mesh 50 x 50 mm in angle-steel frame; For sloping or horizontal insertion; Shelf support interval 120 mm, gradient when sloping 15 degrees; Edge 15 mm high; Tubular push bar welded to one end; Trolleys powder-coated RAL 7016 anthracite grey or RAL 7035 light grey; Permanent surface protection; Impact- and scratch-resistant; Grey non-marking thermoplastic rubber tyres on plastic wheel rim with precision deepgroove ball bearings; Thread guard and foot guard; 2 **EasySTOP** swivel castors and 2 fixed castors.



Shelf trolley with 2 mesh shelves, RAL 7016

Article no.	Dimension			Loading surface		Weight kg	Load cap. kg	Wheel diam. mm
	W	D	H	w	d			
sw-540.223/AG	1510	550	1235	1355	550	47.0	250	160 x 40
sw-640.223/AG	1805	650	1275	1650	650	56.5	400	200 x 40

Load capacity shelf: 50 kg*

EasySTOP swivel castors and foot guards for your safety!



Shelf trolley with 3 mesh shelves, RAL 7016

Article no.	Dimension			Loading surface		Weight kg	Load cap. kg	Wheel diam. mm
	W	D	H	w	d			
sw-540.225/AG	1510	550	1535	1355	550	59.5	250	160 x 40
sw-640.225/AG	1805	650	1575	1650	650	66.0	400	200 x 40

Load capacity shelf: 50 kg*

EasySTOP swivel castors and foot guards for your safety!

Shelf trolley with 4 mesh shelves, RAL 7016

Article no.	Dimension			Loading surface		Weight kg	Load cap. kg	Wheel diam. mm
	W	D	H	w	d			
sw-540.212/AG	1510	550	1815	1355	550	71.0	250	160 x 40
sw-640.212/AG	1805	650	1855	1650	650	79.0	400	200 x 40

Load capacity shelf: 50 kg*

EasySTOP swivel castors and foot guards for your safety!

Additional articles - Mesh shelves for shelf trolley, RAL 7016

Article no.	Dimension		for loading surface		Weight kg	Load cap. kg	
	W	D	w	d			
zsw-540.212/AG	1320	535	1355	550	9.5	50	Additional shelf
zsw-640.212/AG	1615	635	1650	650	10.5	50	



*Static distributed load; Total load of the transport device must not be exceeded!



Shelf trolleys with sloping shelves



Shelf trolley with 2 mesh shelves, RAL 7035

Article no.	Dimension			Loading surface		Weight kg	Load cap. kg	Wheel diam. mm
	W	mm D	H	w	d			
sw-540.223/LG	1510	550	1235	1355	550	47.0	250	160 x 40
sw-640.223/LG	1805	650	1275	1650	650	56.5	400	200 x 40

Load capacity shelf: 50 kg*
EasySTOP swivel castors and foot guards for your safety!



Shelf trolley with 3 mesh shelves, RAL 7035

Article no.	Dimension			Loading surface		Weight kg	Load cap. kg	Wheel diam. mm
	W	mm D	H	w	d			
sw-540.225/LG	1510	550	1535	1355	550	59.5	250	160 x 40
sw-640.225/LG	1805	650	1575	1650	650	66.0	400	200 x 40

Load capacity shelf: 50 kg*
EasySTOP swivel castors and foot guards for your safety!

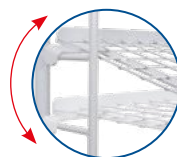

Shelves for insertion
diagonally or horizontal

Shelf trolley with 4 mesh shelves, RAL 7035

Article no.	Dimension			Loading surface		Weight kg	Load cap. kg	Wheel diam. mm
	W	mm D	H	w	d			
sw-540.212/LG	1510	550	1815	1355	550	71.0	250	160 x 40
sw-640.212/LG	1805	650	1855	1650	650	79.0	400	200 x 40

Load capacity shelf: 50 kg*
EasySTOP swivel castors and foot guards for your safety!

Additional articles - Mesh shelves for shelf trolley, RAL 7035

Article no.	Dimension		for loading surface		Weight kg	Load cap. kg	Additional shelf
	W	mm D	w	d			
zsw-540.212/LG	1320	535	1355	550	9.5	50	
zsw-640.212/LG	1615	635	1650	650	10.5	50	

*Static distributed load; Total load of the transport device must not be exceeded!



VARIOFIT®



Small order-picking trolleys

Welded steel construction; Open shelves or with 3 plastic crates (600 x 400 x 220 mm (W/D/H) / 45 l), or of wood-based board, surface coated in dark grey, edge 10 mm high; All small order-picking trolleys suitable for plastic crates 600 x 400 mm (W/D); Middle and upper shelf fixed or tilts to 15° or 30°; Carrying capacity upper and middle shelves: 50 kg; Trolleys powder-coated RAL 7016 anthracite grey or RAL 7035 light grey; Permanent surface protection; Impact- and scratch-resistant; Grey non-marking thermoplastic rubber tyres on plastic wheel rim with precision deepgroove ball bearings; Thread guard and foot guard; 2 **EasySTOP** swivel castors and 2 fixed castors.



Small order-picking trolley, RAL 7016

Article no.	Dimension			Loading surface		Weight kg	Load cap. kg	Wheel diam. mm
	W	D	H	w	d			
sw-400.800/AG	815	455	1185	610	410	21.0	200	125 x 32

Load capacity shelf: 50 kg*
EasySTOP swivel castors and foot guards for your safety!



Small order-picking trolley with 3 plastic crates, RAL 7016

Article no.	Dimension			Loading surface		Weight kg	Load cap. kg	Wheel diam. mm
	W	D	H	w	d			
sw-400.804/AG	815	455	1385	610	410	25.5	200	125 x 32

Load capacity shelf: 50 kg*
EasySTOP swivel castors and foot guards for your safety!

Small order-picking trolley with 3 wooden shelves, RAL 7016

Article no.	Dimension			Loading surface		Weight kg	Load cap. kg	Wheel diam. mm
	W	D	H	w	d			
sw-400.801/AG	815	455	1185	610	410	26.0	200	125 x 32

Load capacity shelf: 50 kg*
EasySTOP swivel castors and foot guards for your safety!



*Static distributed load; Total load of the transport device must not be exceeded!

Small order-picking trolleys



Small order-picking trolley, RAL 7035

Article no.	Dimension			Loading surface		Weight	Load cap.	Wheel diam.
	W	mm D	H	w	mm d			
sw-400.800/LG	815	455	1185	610	410	21.0	200	125 x 32

Load capacity shelf: 50 kg*
EasySTOP swivel castors and foot guards for your safety!

[Plastic crates on page 136](#)

Small order-picking trolley with 3 plastic crates, RAL 7035

Article no.	Dimension			Loading surface		Weight	Load cap.	Wheel diam.
	W	mm D	H	w	mm d			
sw-400.804/LG	815	455	1385	610	410	25.5	200	125 x 32

Load capacity shelf: 50 kg*
EasySTOP swivel castors and foot guards for your safety!



Small order-picking trolley with 3 wooden shelves, RAL 7035

Article no.	Dimension			Loading surface		Weight	Load cap.	Wheel diam.
	W	mm D	H	w	mm d			
sw-400.801/LG	815	455	1185	610	410	26.0	200	125 x 32

Load capacity shelf: 50 kg*
EasySTOP swivel castors and foot guards for your safety!

*Static distributed load; Total load of the transport device must not be exceeded!

Material stands

Welded steel construction; Load surface with 22 mm high edge on one side or 18 mm high edge on all sides; Height adjustment range 500-755, 515-790, 695-1,065 or 750-1,000 mm in steps of 25 mm; Suitable for plastic crates 600 x 400 mm (W/D); Load surfaces fixed or one-sided tilts to 15° or 30°; Secure positioning by spring catch; Material stands powder-coated RAL 7016 anthracite grey or RAL 7035 light grey; Permanent surface protection; Impact- and scratch-resistant; Grey non-marking thermoplastic rubber tyres on plastic wheel rim with precision deepgroove ball bearings; Thread guard and foot guard; 4 swivel castors, 2 of them with brakes.



Material stand, RAL 7016

Article no.	Dimension mm			Loading surface mm		Weight kg	Load cap. kg	Wheel diam. mm
	W	D	H	w	d			
sw-405.000/AG	610	410	770-1020	605	405	16.0	150	75 x 25

Swivel castors with wheel brakes!



Material stand, RAL 7016

Article no.	Dimension mm			Loading surface mm		Weight kg	Load cap. kg	Wheel diam. mm
	W	D	H	w	d			
sw-405.001/AG	610	410	535-810	605	405	14.5	150	75 x 25

Swivel castors with wheel brakes!



Material stand, one-sided tiltable, RAL 7016

Article no.	Dimension mm			Loading surface mm		Weight kg	Load cap. kg	Wheel diam. mm
	W	D	H	w	d			
sw-405.002/AG	600	410	715-1085	510	410	15.0	150	75 x 25

Swivel castors with wheel brakes!

Material stand, one-sided tiltable, RAL 7016

Article no.	Dimension mm			Loading surface mm		Weight kg	Load cap. kg	Wheel diam. mm
	W	D	H	w	d			
sw-405.005/AG	600	410	520-775	510	410	13.5	150	75 x 25

Swivel castors with wheel brakes!



Material stands



Material stand, RAL 7035

Article no.	Dimension			Loading surface		Weight	Load cap.	Wheel diam.
	W	mm D	H	w	mm d			
sw-405.000/LG	610	410	770-1020	605	405	16.0	150	75 x 25

Swivel castors with wheel brakes!

Material stand, RAL 7035

Article no.	Dimension			Loading surface		Weight	Load cap.	Wheel diam.
	W	mm D	H	w	mm d			
sw-405.001/LG	610	410	535-810	605	405	14.5	150	75 x 25

Swivel castors with wheel brakes!



Height adjustment in steps of 25 mm

Material stand, one-sided tiltable, RAL 7035

Article no.	Dimension			Loading surface		Weight	Load cap.	Wheel diam.
	W	mm D	H	w	mm d			
sw-405.002/LG	600	410	715-1085	510	410	15.0	150	75 x 25

Swivel castors with wheel brakes!



Material stand, one-sided tiltable, RAL 7035

Article no.	Dimension			Loading surface		Weight	Load cap.	Wheel diam.
	W	mm D	H	w	mm d			
sw-405.005/LG	600	410	520-775	510	410	13.5	150	75 x 25

Swivel castors with wheel brakes!



Euro system dollies

Welded angle-steel construction; Versions with or without load surface of wood-based board, surface coated in dark grey; Flush with frame or edge 10 mm high; For Euro size container 600 x 400 mm (W/D); Version with two load surfaces with 4 sockets; Dollies powder-coated RAL 7016 anthracite grey or RAL 7035 light grey; Impact- and scratch-resistant; Grey non-marking thermoplastic rubber tyres on plastic wheel rim with precision deepgroove ball bearings; Thread guard and foot guard; 4 swivel castors, 2 of them with brakes.



Euro system dolly, RAL 7016

Article no.	Dimension mm			Loading surface mm		Weight kg	Load cap. kg	Wheel diam. mm
	w	D	H	w	d			
sw-410.003/AG	610	415	205	605	410	8.5	250	125 x 32

Swivel castors with wheel brakes and foot guards for your safety!

Euro system dolly with 2 load surfaces (edge 10 mm), RAL 7016

Article no.	Dimension mm			Loading surface mm		Weight kg	Load cap. kg	Wheel diam. mm
	w	D	H	w	d			
sw-410.500/AG	675	415	635	605	410	19.0	250	125 x 32

Load capacity shelf: 80 kg*

Swivel castors with wheel brakes and foot guards for your safety!



Euro system dolly with 2 load surfaces, RAL 7016

Article no.	Dimension mm			Loading surface mm		Weight kg	Load cap. kg	Wheel diam. mm
	w	D	H	w	d			
sw-410.501/AG	675	415	635	610	415	19.0	250	125 x 32

Load capacity shelf: 80 kg*

Swivel castors with wheel brakes and foot guards for your safety!



*Static distributed load; Total load of the transport device must not be exceeded!

Euro system dollies



Euro system dolly, RAL 7035

Article no.	Dimension			Loading surface		Weight	Load cap.	Wheel diam.
	W	D	H	w	d			
sw-410.003/LG	610	415	205	605	410	8.5	250	125 x 32

Swivel castors with wheel brakes and foot guards for your safety!



Euro system dolly with 2 load surfaces (edge 10 mm), RAL 7035

Article no.	Dimension			Loading surface		Weight	Load cap.	Wheel diam.
	W	D	H	w	d			
sw-410.500/LG	675	415	635	605	410	19.0	250	125 x 32

Load capacity shelf: 80 kg*

Swivel castors with wheel brakes and foot guards for your safety!



Euro system dolly with 2 load surfaces, RAL 7035

Article no.	Dimension			Loading surface		Weight	Load cap.	Wheel diam.
	W	D	H	w	d			
sw-410.501/LG	675	415	635	610	415	19.0	250	125 x 32

Load capacity shelf: 80 kg*

Swivel castors with wheel brakes and foot guards for your safety!

*Static distributed load; Total load of the transport device must not be exceeded!



VARIOFIT®



Crate dollies

Welded steel construction; Load surface of wood-based board, surface coated in dark grey or with diamond-tread; Dollies powder-coated RAL 7016 anthracite grey or RAL 7035 light grey; Permanent surface protection; Impact- and scratch-resistant; Grey non-marking thermoplastic rubber tyres on plastic wheel rim with precision deepgroove ball bearings; Thread guard and foot guard; 4 swivel castors, 2 of them with brakes.



Crate dolly with board load surface, RAL 7016

Article no.	Dimension			Loading surface		Weight kg	Load cap. kg	Wheel diam. mm
	w	mm D	H	w	d			
sw-500.011/AG	500	500	185	500	500	11.5	400	125 x 32

Swivel castors with wheel brakes and foot guards for your safety!



Crate dolly with diamond-tread load surface, RAL 7016

Article no.	Dimension			Loading surface		Weight kg	Load cap. kg	Wheel diam. mm
	w	mm D	H	w	d			
sw-500.012/AG	500	500	170	500	500	12.0	400	125 x 32

Swivel castors with wheel brakes and foot guards for your safety!

Push-handle dollies

Welded steel construction; Load surface of wood based-board, surface coated in dark grey; Screw-on handles; Dollies powder-coated RAL 7016 anthracite grey or RAL 7035 light grey; Permanent surface protection; Impact- and scratch-resistant; Grey non-marking thermoplastic rubber tyres on plastic wheel rim with precision deepgroove ball bearings; Thread guard and foot guard; 2 swivel castors with brakes and 2 fixed castors; Push-handle dolly with 2 load surfaces with 2 **EasySTOP** swivel castors and 2 fixed castors.

Push-handle dolly with board, RAL 7016

Article no.	Dimension			Loading surface		Weight kg	Load cap. kg	Wheel diam. mm
	w	mm D	H	w	d			
sw-500.800/AG	880	500	880	605	500	11.0	250	125 x 32

Swivel castors with wheel brakes and foot guards for your safety!



Push-handle dolly with 2 load surfaces, RAL 7016

Article no.	Dimension			Loading surface		Weight kg	Load cap. kg	Wheel diam. mm
	w	mm D	H	w	d			
sw-450.800/AG	940	455	910	610	455	16.0	200	125 x 32

Load capacity shelf: 80 kg*

EasySTOP swivel castors and foot guards for your safety!



*Static distributed load; Total load of the transport device must not be exceeded!



Crate dollies and push-handle dollies



Crate dolly with board load surface, RAL 7035

Article no.	Dimension			Loading surface		Weight kg	Load cap. kg	Wheel diam. mm
	w	D	H	w	d			
sw-500.011/LG	500	500	185	500	500	11.5	400	125 x 32

Swivel castors with wheel brakes and foot guards for your safety!



Crate dolly with diamond-tread load surface, RAL 7035

Article no.	Dimension			Loading surface		Weight kg	Load cap. kg	Wheel diam. mm
	w	D	H	w	d			
sw-500.012/LG	500	500	170	500	500	12.0	400	125 x 32

Swivel castors with wheel brakes and foot guards for your safety!



Push-handle dolly with board, RAL 7035

Article no.	Dimension			Loading surface		Weight kg	Load cap. kg	Wheel diam. mm
	w	D	H	w	d			
sw-500.800/LG	880	500	880	605	500	11.0	250	125 x 32

Swivel castors with wheel brakes and foot guards for your safety!



Push-handle dolly with 2 load surfaces, RAL 7035

Article no.	Dimension			Loading surface		Weight kg	Load cap. kg	Wheel diam. mm
	w	D	H	w	d			
sw-450.800/LG	940	455	910	610	455	16.0	200	125 x 32

Load capacity shelf: 80 kg*
EasySTOP swivel castors and foot guards for your safety!

*Static distributed load; Total load of the transport device must not be exceeded!



VARIOfit



Tubular steel trucks

Welded steel construction; With 2 innovative plastic safety handles; Toe of sheet steel; Either with bended transverse struts or with verticle struts; Trucks powder-coated RAL 7016 anthracite grey or RAL 7035 light grey; Permanent surface protection; Impact- and scratch-resistant; Pneumatic tyres on steel wheel rim or solid-rubber tyres on special plastic wheel rim with precision deepgroove ball bearings and plastic wheel cap.



Tubular steel truck, RAL 7016

Article no.		Dimension			Toe plate		Weight kg	Load cap. kg	Wheel diam. mm
		W	mm D	H	w	d			
sk-710.015/AG	P	570	530	1105	320	250	12.5	200	260 x 85
sk-710.016/AG	SR	570	530	1105	320	250	14.5	200	260 x 85

P = Pneumatic tyres, SR = Solid-rubber tyres



Tubular steel truck, RAL 7016

Article no.		Dimension			Toe plate		Weight kg	Load cap. kg	Wheel diam. mm
		W	mm D	H	w	d			
sk-710.010/AG	P	570	585	1310	320	250	17.0	250	260 x 85
sk-710.011/AG	SR	570	585	1310	320	250	19.0	250	260 x 85

P = Pneumatic tyres, SR = Solid-rubber tyres

Tubular steel truck, RAL 7016

Article no.		Dimension			Toe plate		Weight kg	Load cap. kg	Wheel diam. mm
		W	mm D	H	w	d			
sk-710.020/AG	P	620	460	1110	400	150	13.5	250	260 x 85
sk-710.021/AG	SR	620	460	1110	400	150	15.5	250	260 x 65

P = Pneumatic tyres, SR = Solid-rubber tyres



Tubular-steel trucks



Tubular steel truck, RAL 7035

Article no.		Dimension			Toe plate		Weight kg	Load cap. kg	Wheel diam. mm
		W	mm D	H	w mm	d			
sk-710.015/LG	P	570	530	1105	320	250	12.5	200	260 x 85
sk-710.016/LG	SR	570	530	1105	320	250	14.5	200	260 x 65

P = Pneumatic tyres, SR = Solid-rubber tyres

Tubular steel truck, RAL 7035

Article no.		Dimension			Toe plate		Weight kg	Load cap. kg	Wheel diam. mm
		W	mm D	H	w mm	d			
sk-710.010/LG	P	570	585	1310	320	250	17.0	250	260 x 85
sk-710.011/LG	SR	570	585	1310	320	250	19.0	250	260 x 65

P = Pneumatic tyres, SR = Solid-rubber tyres



Tubular steel truck, RAL 7035

Article no.		Dimension			Toe plate		Weight kg	Load cap. kg	Wheel diam. mm
		W	mm D	H	w mm	d			
sk-710.020/LG	P	620	460	1110	400	150	13.5	250	260 x 85
sk-710.021/LG	SR	620	460	1110	400	150	15.5	250	260 x 65

P = Pneumatic tyres, SR = Solid-rubber tyres

Tubular steel trucks

Welded steel construction; With 2 innovative plastic safety handles; Toe of sheet steel; With bended transverse strut; Plastic skids are replaceable and mounted completely on the tube; Trucks powder-coated RAL 7016 anthracite grey or RAL 7035 light grey; Permanent surface protection; Impact- and scratch-resistant; Pneumatic tyres on steel wheel rim or solid-rubber tyres on special plastic wheel rim with precision deepgroove ball bearings and plastic wheel cap; Optional with puncture-proof tyres.



Tubular steel truck, RAL 7016

Article no.		Dimension mm			Toe plate mm		Weight kg	Load cap. kg	Wheel diam. mm
		W	D	H	w	d			
sk-710.005/AG	P	550	615	1305	320	250	18.0	250	260 x 85
sk-710.006 /AG	SR	550	615	1305	320	250	19.5	250	260 x 65

P = Pneumatic tyres, SR = Solid-rubber tyres



Tubular steel truck with puncture-proof tyres, RAL 7016

Article no.		Dimension mm			Toe plate mm		Weight kg	Load cap. kg	Wheel diam. mm
		w	D	H	w	d			
sk-710.014/AG		550	615	1305	320	250	18.5	250	260 x 85

Stair-climber trucks

Welded steel construction; With 2 innovative plastic safety handles; Toe of sheet steel; With bended transverse struts; Trucks powder-coated RAL 7016 anthracite grey or RAL 7035 light grey; Permanent surface protection; Impact- and scratch-resistant; 2 three-arm star wheels; Screwed; Three-arm star wheels of grey non-marking thermoplastic rubber tyres on plastic wheel rim with precision deepgroove ball bearings; Thread guard.

Stair-climber truck with 2 three-arm star wheels, RAL 7016

Article no.		Dimension mm			Toe plate mm		Weight kg	Load cap. kg	Wheel diam. mm
		w	D	H	w	d			
sk-1300/AG	TR	610	630	1310	300	255	23.5	200	160 x 40

TR = Thermoplastic rubber tyres



Tubular-steel trucks and stair-climber trucks



Tubular steel truck, RAL 7035

Article no.		Dimension mm			Toe plate mm		Weight kg	Load cap. kg	Wheel diam. mm
		W	D	H	w	d			
sk-710.005/LG	P	550	615	1305	320	250	18.0	250	260 x 85
sk-710.006/LG	SR	550	615	1305	320	250	19.5	250	260 x 65

P = Pneumatic tyres, SR = Solid-rubber tyres

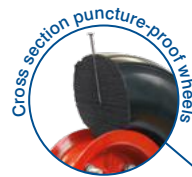

Tubular steel truck with puncture-proof tyres, RAL 7035

Article no.		Dimension mm			Toe plate mm		Weight kg	Load cap. kg	Wheel diam. mm
		W	D	H	w	d			
sk-710.014/LG		550	615	1305	320	250	18.5	250	260 x 85



Stair-climber truck with 2 three-arm star wheels, RAL 7035

Article no.		Dimension mm			Toe plate mm		Weight kg	Load cap. kg	Wheel diam. mm
		W	D	H	w	d			
sk-1300/LG	TR	610	630	1310	300	255	23.5	200	160 x 40

TR = Thermoplastic rubber tyres

Steel-cylinder trucks

Welded steel construction; With 2 innovative plastic safety handles; Toe of sheet steel with edge surrounded on three sides; For easy transport of steel cylinders with a capacity of 20, 40 or 50 l; Diameter 210 – 250 mm; Cylinder holder with safety chains; Trucks powder-coated RAL 7016 anthracite grey or RAL 7035 light grey; Permanent surface protection; Impact- and scratch-resistant; Pneumatic or solid-rubber tyres on steel wheel rim, solid-rubber tyres with diameter 260 x 65 mm on special plastic wheel rim with precision deepgroove ball bearings and plastic wheel cap.



Steel-cylinder truck for 1 steel-cylinder of 40 - 50 l capacity, RAL 7016

Article no.		Dimension mm			Toe plate mm		Weight kg	Load cap. kg	Wheel diam. mm
		W	D	H	w	d			
fk-1201/AG	P	465	445	1185	255	260	9.5	100	260 x 85
fk-1200/AG	SR	465	445	1185	255	260	11.0	100	260 x 65

P = Pneumatic tyres, SR = Solid-rubber tyres



Steel-cylinder truck for 1 steel-cylinder of 20, 40 - 50 l capacity, RAL 7016

Article no.		Dimension mm			Toe plate mm		Weight kg	Load cap. kg	Wheel diam. mm
		W	D	H	w	d			
fk-1201.001/AG	P	465	445	1185	255	260	9.5	100	260 x 85
fk-1200.001/AG	SR	465	445	1185	255	260	11.0	100	260 x 65

P = Pneumatic tyres, SR = Solid-rubber tyres

Steel-cylinder truck for 2 steel-cylinders of 40 - 50 l capacity, RAL 7016

Article no.		Dimension mm			Toe plate mm		Weight kg	Load cap. kg	Wheel diam. mm
		W	D	H	w	d			
fk-1301/AG	P	855	975	1240	515	250	24.5	200	400 x 100
fk-1300/AG	SR	855	975	1240	515	250	37.5	200	400 x 80

P = Pneumatic tyres, SR = Solid-rubber tyres



Handling of steel-cylinder trucks

Steel-cylinder truck for 1 steel-cylinder of 40 - 50 l capacity, RAL 7035

Article no.		Dimension			Toe plate		Weight kg	Load cap. kg	Wheel diam. mm
		w	mm D	H	w	d			
fk-1201/LG	P	465	445	1185	255	260	9.5	100	260 x 85
fk-1200/LG	SR	465	445	1185	255	260	11.0	100	260 x 65

P = Pneumatic tyres, SR = Solid-rubber tyres

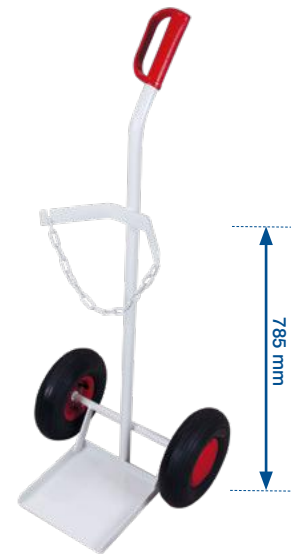

Steel-cylinder truck for 1 steel-cylinder of 20, 40 - 50 l capacity, RAL 7035

Article no.		Dimension			Toe plate		Weight kg	Load cap. kg	Wheel diam. mm
		w	mm D	H	w	d			
fk-1201.001/LG	P	465	445	1185	255	260	9.5	100	260 x 85
fk-1200.001/LG	SR	465	445	1185	255	260	11.0	100	260 x 65

P = Pneumatic tyres, SR = Solid-rubber tyres



Steel-cylinder truck for 2 steel-cylinders of 40 - 50 l capacity, RAL 7035

Article no.		Dimension			Toe plate		Weight kg	Load cap. kg	Wheel diam. mm
		w	mm D	H	w	d			
fk-1301/LG	P	855	975	1240	515	250	24.5	200	400 x 100
fk-1300/LG	SR	855	975	1240	515	250	37.5	200	400 x 80

P = Pneumatic tyres, SR = Solid-rubber tyres



Drum dollies

Welded steel construction of flat steel; Edge height: 40 mm; For upright transport of 200 l drums; Optional with screwed push bar and webbing strap for securing load; Dollies powder-coated RAL 7016 anthracite grey or RAL 7035 light grey; Permanent surface protection; Impact- and scratch-resistant; Grey non-marking thermoplastic rubber tyres on plastic wheel rim with precision deepgroove ball bearings; Thread guard; 4 swivel castors 2 of them with brakes.



Drum dolly, RAL 7016

Article no.		Dimension mm			Loading surface	Weight kg	Load cap. kg	Wheel diam. mm
		W	D diam.	H				
sw-610.000/AG	TR	715	610	160	for 200 l drums	9.5	250	80 x 30

TR = Thermoplastic rubber tyre



Drum dolly with push bar, RAL 7016

Article no.		Dimension mm			Loading surface	Weight kg	Load cap. kg	Wheel diam. mm
		W	D diam.	H				
sw-610.010/AG	TR	715	610	930	for 200 l drums	13.5	250	80 x 30

Incl. webbing strap for securing drum
TR = Thermoplastic rubber tyres

Sheet-material trucks

Sheet-material trucks

Welded tubular steel construction; Sheet-steel platform; Toe plate sloping towards supporting frame, welded to substructure; Tilt 22°; For lengthways transport of large wood and plastic panels; Trucks powder-coated RAL 7016 anthracite grey or RAL 7035 light grey; Permanent surface protection; Impact- and scratch-resistant; Pneumatic tyres on steel wheel rim or solid-rubber tyres on special plastic wheel rim with precision deepgroove ball bearings and plastic wheel cap, plus 2 support rollers.



Sheet-material truck, RAL 7016

Article no.		Dimension mm			Toe plate mm		Weight kg	Load cap. kg	Wheel diam. mm
		w	D	H	w	d			
sk-710.035/AG	P	1260	680	1425	500	200	18.5	250	260 x 85
sk-710.036/AG	SR	1260	680	1425	500	200	20.0	250	260 x 65

P = Pneumatic tyres, SR = Solid-rubber tyres



Handling of drums



Drum dolly, RAL 7035

Article no.		Dimension mm			Loading surface	Weight kg	Load cap. kg	Wheel diam. mm
		W	D diam.	H				
sw-610.000/LG	TR	715	610	160	for 200 l drums	9.5	250	80 x 30

TR = Thermoplastic rubber tyre



Drum dolly with push bar, RAL 7035

Article no.		Dimension mm			Loading surface	Weight kg	Load cap. kg	Wheel diam. mm
		W	D diam.	H				
sw-610.010/LG	TR	715	610	930	for 200 l drums	13.5	250	80 x 30

Incl. webbing strap for securing drum
TR = Thermoplastic rubber tyres



Sheet-material truck, RAL 7035

Article no.		Dimension mm			Toe plate		Weight kg	Load cap. kg	Wheel diam. mm
		w	D	H	w	d			
sk-710.035/LG	P	1260	680	1425	500	200	18.5	250	260 x 85
sk-710.036/LG	SR	1260	680	1425	500	200	20.0	250	260 x 65

P = Pneumatic tyres, SR = Solid-rubber tyres





Steel-frame dollies for pallets

Welded steel construction; Suitable for Euro pallets or cage pallets; Incl. locating cups; Dollies powder-coated RAL 7016 anthracite grey or RAL 7035 light grey; Permanent surface protection; Impact- and scratch-resistant; Grey non-marking thermoplastic rubber tyres on plastic wheel rim with precision deepgroove ball bearings; Thread guard and foot guard, or polyamide tyres with precision deepgroove ball bearing with foot guard; 2 **EasySTOP** swivel castors and 2 fixed castors.



Steel-frame dolly, RAL 7016

Article no.		Dimension			Loading surface		Weight kg	Load cap. kg	Wheel diam. mm
		W	mm D	H	w	d			
sw-870.041/AG	TR	870	670	350	810	610	25.0	500	200 x 40
sw-870.015/AG	TR	1070	870	350	1010	810	28.0	500	200 x 40
sw-870.000/AG	TR	1270	870	350	1210	810	32.0	500	200 x 40
sw-870.020/AG	TR	1270	1070	350	1210	1010	32.5	500	200 x 40

EasySTOP swivel castors and foot guards for your safety!

TR = Thermoplastic rubber tyres



Steel-frame dolly, RAL 7016

Article no.		Dimension			Loading surface		Weight kg	Load cap. kg	Wheel diam. mm
		W	mm D	H	w	d			
sw-870.441/AG	PT	870	670	350	810	610	25.0	1050	200 x 50
sw-870.415/AG	PT	1070	870	350	1010	810	27.5	1050	200 x 50
sw-870.400/AG	PT	1270	870	350	1210	810	31.5	1050	200 x 50
sw-870.420/AG	PT	1270	1070	350	1210	1010	32.5	1050	200 x 50

EasySTOP swivel castors and foot guards for your safety!

PT = Polyamide tyres



Handling of pallets



Steel-frame dolly, RAL 7035

Article no.		Dimension mm			Loading surface mm		Weight kg	Load cap. kg	Wheel diam. mm
		w	D	H	w	d			
sw-870.041/LG	TR	870	670	350	810	610	25.0	500	200 x 40
sw-870.015/LG	TR	1070	870	350	1010	810	28.0	500	200 x 40
sw-870.000/LG	TR	1270	870	350	1210	810	32.0	500	200 x 40
sw-870.020/LG	TR	1270	1070	350	1210	1010	32.5	500	200 x 40

EasySTOP swivel castors and foot guards for your safety!
TR = Thermoplastic rubber tyres



Steel-frame dolly, RAL 7035

Article no.		Dimension mm			Loading surface mm		Weight kg	Load cap. kg	Wheel diam. mm
		w	D	H	w	d			
sw-870.441/LG	PT	870	670	350	810	610	25.0	1050	200 x 50
sw-870.415/LG	PT	1070	870	350	1010	810	27.5	1050	200 x 50
sw-870.400/LG	PT	1270	870	350	1210	810	31.5	1050	200 x 50
sw-870.420/LG	PT	1270	1070	350	1210	1010	32.5	1050	200 x 50

EasySTOP swivel castors and foot guards for your safety!
PT = Polyamide tyres





Steel-frame dollies for pallets

Welded steel construction; Suitable for Euro pallets or cage pallets; Incl. locating cups; Dollies powder-coated RAL 7016 anthracite grey or RAL 7035 light grey; Permanent surface protection; Impact- and scratch-resistant; Elastic solid-rubber tyres on cast aluminium wheel rim with precision deepgroove ball bearings with foot guard, or polyurethane tyres 92° Shore A on cast aluminium wheel rim with precision deepgroove ball bearings with foot guard; 2 **EasySTOP** swivel castors and 2 fixed castors.



Steel-frame dolly, RAL 7016

Article no.		Dimension			Loading surface		Weight kg	Load cap. kg	Wheel diam. mm
		w	mm D	H	w	d			
sw-870.042/AG	ER	870	670	350	810	610	29.5	1200	200 x 50
sw-870.036/AG	ER	1070	870	350	1010	810	32.5	1200	200 x 50
sw-870.001/AG	ER	1270	870	350	1210	810	35.5	1200	200 x 50
sw-870.501/AG	ER	1270	1070	350	1210	1010	37.5	1200	200 x 50

EasySTOP swivel castors and foot guards for your safety!
ER = Elastic solid-rubber tyres



Steel-frame dolly, RAL 7016

Article no.		Dimension			Loading surface		Weight kg	Load cap. kg	Wheel diam. mm
		w	mm D	H	w	d			
sw-870.341/AG	PO	870	670	350	810	610	39.0	1800	200 x 50
sw-870.315/AG	PO	1070	870	350	1010	810	44.0	1800	200 x 50
sw-870.300/AG	PO	1270	870	350	1210	810	47.5	1800	200 x 50
sw-870.514/AG	PO	1270	1070	350	1210	1010	49.5	1800	200 x 50

EasySTOP swivel castors and foot guards for your safety!
PO = Polyurethane tyres

Handling of pallets



Steel-frame dolly, RAL 7035

Article no.		Dimension			Loading surface		Weight kg	Load cap. kg	Wheel diam. mm
		w	D	H	w	d			
sw-870.042/LG	ER	870	670	350	810	610	29.5	1200	200 x 50
sw-870.036/LG	ER	1070	870	350	1010	810	32.5	1200	200 x 50
sw-870.001/LG	ER	1270	870	350	1210	810	35.5	1200	200 x 50
sw-870.501/LG	ER	1270	1070	350	1210	1010	37.5	1200	200 x 50

EasySTOP swivel castors and foot guards for your safety!
ER = Elastic solid-rubber tyres



Steel-frame dolly, RAL 7035

Article no.		Dimension			Loading surface		Weight kg	Load cap. kg	Wheel diam. mm
		w	D	H	w	d			
sw-870.341/LG	PO	870	670	350	810	610	39.0	1800	200 x 50
sw-870.315/LG	PO	1070	870	350	1010	810	44.0	1800	200 x 50
sw-870.300/LG	PO	1270	870	350	1210	810	47.5	1800	200 x 50
sw-870.514/LG	PO	1270	1070	350	1210	1010	49.5	1800	200 x 50

EasySTOP swivel castors and foot guards for your safety!
PO = Polyurethane tyres

Steel-frame dollies for pallets

Welded steel construction; Suitable for Euro pallets or cage pallets; Incl. locating cups; 4 connecting tubes for insert into edges; Add-on frame stackable on connecting tubes; Variable removable; Dollies powder-coated RAL 7016 anthracite grey or RAL 7035 light grey; Permanent surface protection; Impact- and scratch-resistant; Grey non-marking thermoplastic rubber tyres on plastic wheel rim with precision deepgroove ball bearings; Thread guard and foot guard, or elastic solid-rubber tyres on cast aluminium wheel rim with precision deepgroove ball bearings with foot guard; 2 **EasySTOP** swivel castors and 2 fixed castors.



Steel-frame dolly with 2 angle-steel-frames, RAL 7016

Article no.		Dimension			Loading surface		Weight kg	Load cap. kg	Wheel diam. mm
		W	mm D	H	w	mm d			
sw-870.113/AG	TR	870	670	720	810	610	40.5	500	200 x 40
sw-870.114/AG	TR	1070	870	720	1010	810	44.0	500	200 x 40
sw-870.100/AG	TR	1270	870	720	1210	810	48.0	500	200 x 40
sw-870.506/AG	TR	1270	1070	720	1210	1010	49.5	500	200 x 40

EasySTOP swivel castors and foot guards for your safety!
TR = Thermoplastic rubber tyres



Steel-frame dolly with 2 angle-steel-frames, RAL 7016

Article no.		Dimension			Loading surface		Weight kg	Load cap. kg	Wheel diam. mm
		W	mm D	H	w	mm d			
sw-870.115/AG	ER	870	670	720	810	610	45.0	1200	200 x 50
sw-870.116/AG	ER	1070	870	720	1010	810	48.5	1200	200 x 50
sw-870.101/AG	ER	1270	870	720	1210	810	50.5	1200	200 x 50
sw-870.507/AG	ER	1270	1070	720	1210	1010	54.5	1200	200 x 50

EasySTOP swivel castors and foot guards for your safety!
ER = Elastic solid-rubber tyres

Accessories

Add-on frame

Welded steel construction; Incl. 4 locating corners; Height adjustment by internal spring-loaded bolt; Add-on frame can be bolted to dolly; Frame powder-coated RAL 7016 anthracite grey or RAL 7035 light grey; Permanent surface protection; Impact- and scratch-resistant.

Loading heights

- 1 650 mm 3 555 mm
- 2 605 mm 4 505 mm

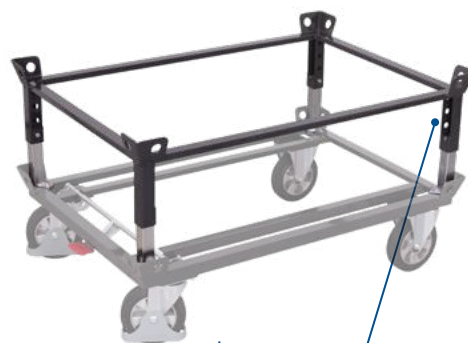

Add-on frame, RAL 7016

Article no.	Dimension		Loading surface		Weight kg	Load cap. kg
	W mm	D mm	w mm	d mm		
zsw-870.101/AG	870	670	810	610	14.5	in accordance with the steel- frame dolly
zsw-870.102/AG	1070	870	1010	810	16.5	
zsw-870.103/AG	1270	870	1210	810	17.0	
zsw-870.104/AG	1270	1070	1210	1010	17.5	



Handling of pallets

Steel-frame dolly with 2 angle-steel-frames, RAL 7035

Article no.		Dimension			Loading surface		Weight kg	Load cap. kg	Wheel diam. mm
		w	mm D	H	w	d			
sw-870.113/LG	TR	870	670	720	810	610	40.5	500	200 x 40
sw-870.114/LG	TR	1070	870	720	1010	810	44.0	500	200 x 40
sw-870.100/LG	TR	1270	870	720	1210	810	48.0	500	200 x 40
sw-870.506/LG	TR	1270	1070	720	1210	1010	49.5	500	200 x 40

EasySTOP swivel castors and foot guards for your safety!
TR = Thermoplastic rubber tyres



Steel-frame dolly with 2 angle-steel-frames, RAL 7035

Article no.		Dimension			Loading surface		Weight kg	Load cap. kg	Wheel diam. mm
		w	mm D	H	w	d			
sw-870.115/LG	ER	870	670	720	810	610	45.0	1200	200 x 50
sw-870.116/LG	ER	1070	870	720	1010	810	48.5	1200	200 x 50
sw-870.101/LG	ER	1270	870	720	1210	810	50.5	1200	200 x 50
sw-870.507/LG	ER	1270	1070	720	1210	1010	54.5	1200	200 x 50

EasySTOP swivel castors and foot guards for your safety!
ER = Elastic solid-rubber tyres



Loading heights
 1 650 mm 3 555 mm
 2 605 mm 4 505 mm

Add-on frame, RAL 7035

Article no.	Dimension		Loading surface		Weight kg	Load cap. kg
	w	D	w	d		
zsw-870.101/LG	870	670	810	610	14.5	in accordance with the steel-frame dolly
zsw-870.102/LG	1070	870	1010	810	16.5	
zsw-870.103/LG	1270	870	1210	810	17.0	
zsw-870.104/LG	1270	1070	1210	1010	17.5	



Additional article - Push bar for steel-frame dollies, RAL 7016

Article no.	Dimension mm		Weight kg
	D	H	
zsw-870.002/AG	500	765	Push bar 5.5

Universal for all sizes, only for combined order with steel-frame dolly (sockets fixed welded, push bar screwed)

Additional article - Shaft and coupling for steel-frame dollies, RAL 7016

Article no.	Dimension mm		Weight kg
	D	H	
zsw-870.003/AG	680		Shaft and coupling 5.0

Universal for all sizes, only for combined order with steel-frame dolly (fixed welded)



Additional article - Push bar with lever release for steel-frame dollies, RAL 7016

Article no.	Dimension mm			Weight kg
	W	D	H	
zsw-870.540/AG	500	335	825	Push bar 6.0

Universal for all sizes

Handling of pallets

Additional article - Push bar for steel-frame dollies, RAL 7035

Article no.	Dimension mm		Weight kg
	D	H	
zsw-870.002/LG	500	765	Push bar 5.5

Universal for all sizes, only for combined order with steel-frame dolly (sockets fixed welded, push bar screwed)



Additional article - Shaft and coupling for steel-frame dollies, RAL 7035

Article no.	Dimension mm		Weight kg
	D	H	
zsw-870.003/LG	680		Shaft and coupling 5.0

Universal for all sizes, only for combined order with steel-frame dolly (fixed welded)



Additional article - Push bar with lever release for steel-frame dollies, RAL 7035

Article no.	Dimension mm			Weight kg
	W	D	H	
zsw-870.540/LG	500	335	825	Push bar 6.0

Universal for all sizes

Our presentation trolley

available in 4 languages

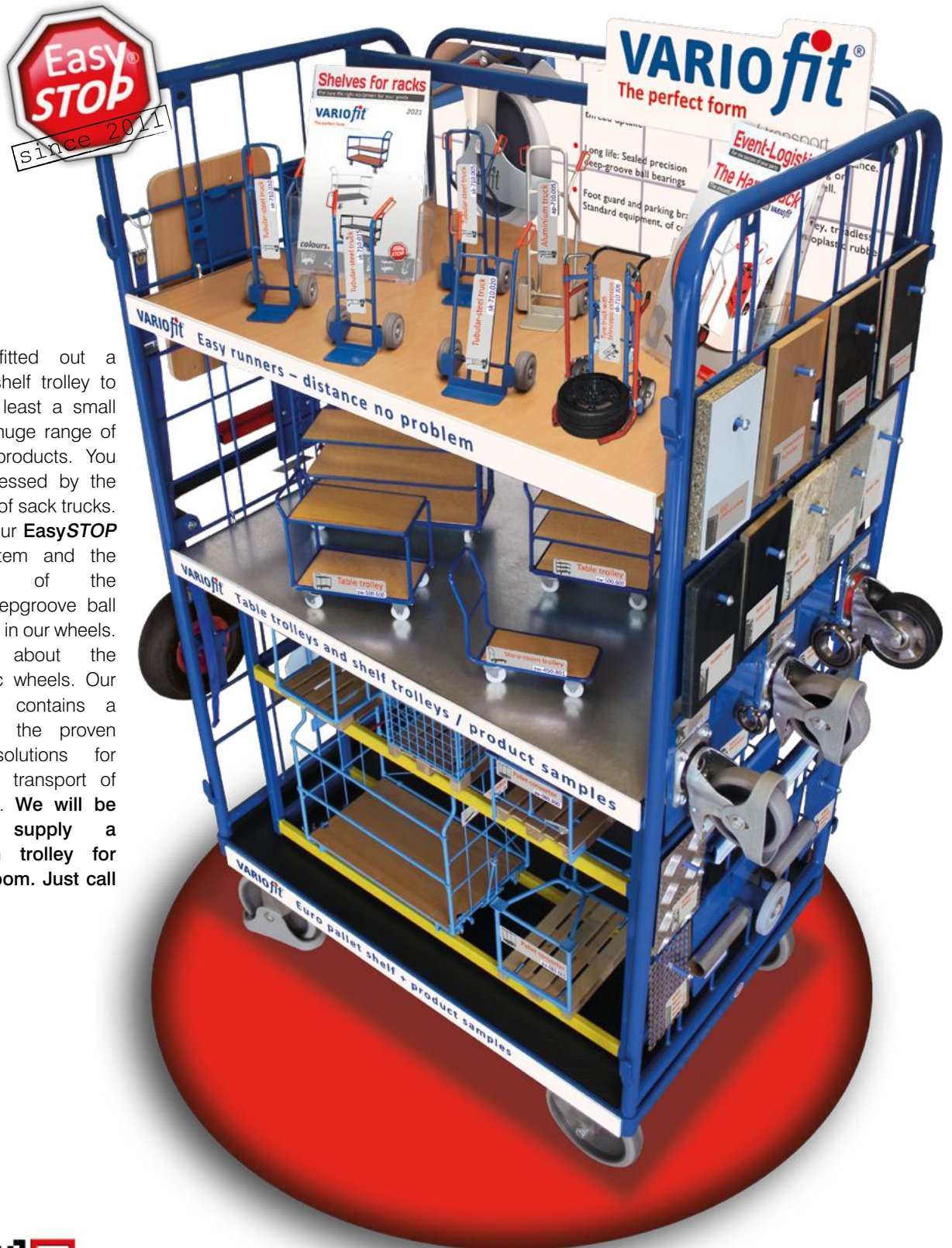

We have fitted out a **VARIOfit**® shelf trolley to give you at least a small idea of the huge range of **VARIOfit**® products. You will be impressed by the great variety of sack trucks. Experience our **EasySTOP** braking system and the smoothness of the precision deepgroove ball bearing used in our wheels. Read all about the thermoplastic wheels. Our trolley also contains a selection of the proven CORDES solutions for storage and transport of bulky goods. We will be glad to supply a presentation trolley for your showroom. Just call us!



VARIOfit® Catalogue
Download

One Base - many facilities



Four basic platforms of different sizes form the basis for almost all types of bodies that are mounted using a sturdy screwed connection. So it's also easy to adapt **VARIOfit**® products bearing this symbol to different requirements. In this way **VARIOfit**® remains affordable and retains its intrinsic value for the customer.



The base



Modular system; Base structure with innovative frame section; Load surface of wood-based board, surface finish beech; Trolley powder-coated RAL 5010 gentian blue; Permanent surface protection; Impact- and scratch-resistant; Grey non-marking thermoplastic rubber tyres on plastic wheel rim with precision deepgroove ball bearings; Thread guard and foot guard; 2 **EasySTOP** swivel castors and 2 fixed castors.



Platform trolley

Article no.	Dimension			Loading surface		Weight kg	Load cap. kg	Wheel diam. mm
	w	mm D	H	w	mm d			
sw-500.000	910	500	255	910	500	20.5	400	160 x 40
sw-600.000	1060	600	295	1060	600	25.0	500	200 x 40
sw-700.000	1060	700	295	1060	700	26.0	500	200 x 40
sw-800.000	1260	800	295	1260	800	32.0	500	200 x 40

EasySTOP swivel castors and foot guards for your safety!



VARIOfit®

Push bar trolleys



Push bar trolleys

Modular system; Base structure with innovative frame section, or of round pipe; Load surface of wood-based board, surface finish beech, or of waterproof bonded plywood, surface finish screen printed, anti-slip; Trolleys powder-coated RAL 5010 gentian blue; Permanent surface protection; Impact- and scratch-resistant; Grey non-marking thermo-plastic rubber tyres on plastic wheel rim with precision deepgroove ball bearings; Thread guard and foot guard, or elastic solid-rubber tyres on cast aluminium wheel rim with precision deepgroove ball bearings with foot guard; 2 **EasySTOP** swivel castors and 2 fixed castors.

Also available in ESD design on page 104

Push bar trolley

Article no.	Dimension mm			Loading surface mm		Weight kg	Load cap. kg	Wheel diam. mm
	w	D	H	w	d			
sw-500.100	975	500	975	880	500	25.0	400	160 x 40
sw-600.100	1125	600	1015	1030	600	29.5	500	200 x 40
sw-700.100	1125	700	1015	1030	700	33.5	500	200 x 40
sw-800.100	1325	800	1015	1230	800	37.0	500	200 x 40

EasySTOP swivel castors and foot guards for your safety!

Push bar trolley

Article no.	Dimension mm			Loading surface mm		Weight kg	Load cap. kg	Wheel diam. mm
	w	D	H	w	d			
sw-500.103	950	500	990	850	500	23.5	400	160 x 40
sw-700.103	1100	700	1030	1000	700	28.0	400	200 x 40
sw-700.104	1300	700	1030	1200	700	32.5	400	200 x 40

EasySTOP swivel castors and foot guards for your safety!

Light version tubular steel push bar trolley

Article no.	Dimension mm			Loading surface mm		Weight kg	Load cap. kg	Wheel diam. mm
	w	D	H	w	d			
sw-450.103	950	450	945	850	450	17.0	200	125 x 32
sw-600.109	1100	600	945	1000	600	22.5	200	125 x 32

EasySTOP swivel castors and foot guards for your safety!

Push bar trolley with screen printing plate

Article no.	Dimension mm			Loading surface mm		Weight kg	Load cap. kg	Wheel diam. mm
	w	D	H	w	d			
sw-700.180	1130	700	1015	1025	700	36.0	1000	200 x 50
sw-800.180	1330	800	1015	1225	800	44.0	1000	200 x 50
sw-800.181	1730	800	1015	1625	800	51.0	1000	200 x 50
sw-800.184	2130	800	1015	2025	800	58.0	1000	200 x 50

EasySTOP swivel castors and foot guards for your safety!





Push bar trolley with bended tubes

Article no.	Dimension			Loading surface		Weight	Load cap.	Wheel diam.
	W	D	H	w	d			
sw-500.119	975	500	935	880	500	21.5	250	125 x 32
sw-600.119	1125	600	935	1030	600	25.0	250	125 x 32

EasySTOP swivel castors and foot guards for your safety!

Double-end push bar trolley with bended tubes

Article no.	Dimension			Loading surface		Weight	Load cap.	Wheel diam.
	W	D	H	w	d			
sw-500.219	1040	500	935	850	500	26.0	250	125 x 32
sw-600.219	1190	600	935	1000	600	30.0	250	125 x 32

EasySTOP swivel castors and foot guards for your safety!



Push bar trolley with vertical tubes

Article no.	Dimension			Loading surface		Weight	Load cap.	Wheel diam.
	W	D	H	w	d			
sw-500.105	950	500	990	850	500	25.5	400	160 x 40
sw-700.105	1100	700	1030	1000	700	31.0	400	200 x 40
sw-700.106	1300	700	1030	1200	700	33.5	400	200 x 40

EasySTOP swivel castors and foot guards for your safety!



Table trolley with push bar

Article no.	Dimension			Loading surface		Weight	Load cap.	Wheel diam.
	W	D	H	w	d			
sw-500.503	955	505	990	850	500	31.5	400	160 x 40
sw-700.503	1105	705	1030	1000	700	40.0	400	200 x 40
sw-700.504	1305	705	1030	1200	700	47.5	400	200 x 40

Load capacity shelf: 120 kg*
EasySTOP swivel castors and foot guards for your safety!

*Static distributed load; Total load of the transport device must not be exceeded!

Push bar trolleys



Push bar trolley with dead man's brake

Base structure with innovative frame section; Fixed welded tubular push bar with dead man's control; Additional handle beneath the push bar; Load surface of wood-based board, surface finish beech; Trolley powder-coated RAL 5010 gentian blue; Permanent surface protection; Impact- and scratch-resistant; Grey non-marking thermoplastic rubber tyres on plastic wheel rim with precision deep-groove ball bearings; Thread guard and foot guard; 2 swivel castors with dead man's brake and 2 fixed castors.

Brake applied

Brake released



Push bar trolley with dead man's brake

Article no.	Dimension			Loading surface		Weight kg	Load cap. kg	Wheel diam. mm
	W	mm D	H	w	d			
sw-600.125	945	600	1015	800	600	25.5	250	125 x 32

Swivel castors with dead man's brake and foot guards for your safety!

Store-room trolley

Robust welded steel construction; Transverse strut in push bar; Load surface of wood-based board; Surface finish beech; Store-room trolley powder-coated RAL 5010 gentian blue; Permanent surface protection; Impact- and scratch-resistant; Grey non-marking thermoplastic rubber tyres on plastic wheel rim with precision deepgroove ball bearings; Thread guard and foot guard; 2 **EasySTOP** swivel castors and 2 fixed castors.

Store-room trolley

Article no.	Dimension			Loading surface		Weight kg	Load cap. kg	Wheel diam. mm
	W	mm D	H	w	d			
sw-450.801	1115	450	970	890	450	16.0	200	125 x 32
sw-600.800	1265	600	970	1040	600	22.0	200	125 x 32

EasySTOP swivel castors and foot guards for your safety!



Aluminium store-room trolley

Robust welded aluminium construction; Transverse strut in push bar; Load surface of waterproof bonded plywood, surface finish screen printed, anti-slip; Grey non-marking thermoplastic rubber tyres on plastic wheel rim with precision deepgroove ball bearings; Thread guard and foot guard; 2 **EasySTOP** swivel castors and 2 fixed castors.

Aluminium store-room trolley

Article no.	Dimension			Loading surface		Weight kg	Load cap. kg	Wheel diam. mm
	W	mm D	H	w	d			
ap-421.000	995	440	975	845	440	9.5	200	125 x 32

EasySTOP swivel castors and foot guards for your safety!



System trolleys with board sides



System trolleys with board sides

Modular system; Base structure with innovative frame section; Load surface, end and side walls of wood-based board, surface finish beech; Side walls 500 mm high and removable; Trolleys powder-coated RAL 5010 gentian blue; Permanent surface protection; Impact- and scratch-resistant; Grey non-marking thermoplastic rubber tyres on plastic wheel rim with precision deepgroove ball bearings; Thread guard and foot guard; 2 **EasySTOP** swivel castors and 2 fixed castors.



Single-end trolley with board

Article no.	Dimension mm			Loading surface mm		Weight kg	Load cap. kg	Wheel diam. mm
	w	D	H	w	d			
sw-500.102	975	500	975	880	500	26.0	400	160 x 40
sw-600.102	1125	600	1015	1030	600	30.0	500	200 x 40
sw-700.102	1125	700	1015	1030	700	33.0	500	200 x 40
sw-800.102	1325	800	1015	1230	800	39.0	500	200 x 40

EasySTOP swivel castors and foot guards for your safety!



Double-end trolley with board

Article no.	Dimension mm			Loading surface mm		Weight kg	Load cap. kg	Wheel diam. mm
	w	D	H	w	d			
sw-500.202	1040	500	975	850	500	30.5	400	160 x 40
sw-600.222	1190	600	1015	1000	600	34.5	500	200 x 40
sw-700.202	1190	700	1015	1000	700	40.0	500	200 x 40
sw-800.202	1390	800	1015	1200	800	45.5	500	200 x 40

EasySTOP swivel castors and foot guards for your safety!



Three-sided trolley with board

Article no.	Dimension mm			Loading surface mm		Weight kg	Load cap. kg	Wheel diam. mm
	w	D	H	w	d			
sw-500.302	1040	500	975	850	475	38.0	400	160 x 40
sw-600.302	1190	600	1015	1000	575	45.0	500	200 x 40
sw-700.302	1190	700	1015	1000	675	48.5	500	200 x 40
sw-800.302	1390	800	1015	1200	775	56.0	500	200 x 40

EasySTOP swivel castors and foot guards for your safety!

Side wall fixing



Four-sided trolley with board

Article no.	Dimension mm			Loading surface mm		Weight kg	Load cap. kg	Wheel diam. mm
	w	D	H	w	d			
sw-500.400	1040	500	975	850	450	43.5	400	160 x 40
sw-600.400	1190	600	1015	1000	550	51.0	500	200 x 40
sw-700.400	1190	700	1015	1000	650	54.0	500	200 x 40
sw-800.400	1390	800	1015	1200	750	61.0	500	200 x 40

EasySTOP swivel castors and foot guards for your safety!

System trolleys with mesh sides



System trolleys with mesh sides

Modular system; Base structure with innovative frame section; Load surface of wood-based board, surface finish beech; End and side walls of mesh with size 50 x 50 mm; Side walls 500 mm high and removable; Trolleys powder-coated RAL 5010 gentian blue; Permanent surface protection; Impact- and scratch-resistant; Grey non-marking thermoplastic rubber tyres on plastic wheel rim with precision deep-groove ball bearings; Thread guard and foot guard; 2 **EasySTOP** swivel castors and 2 fixed castors.



Single-end trolley with mesh

Article no.	Dimension mm			Loading surface mm		Weight kg	Load cap. kg	Wheel diam. mm
	w	D	H	w	d			
sw-500.101	975	500	975	880	500	25.0	400	160 x 40
sw-600.101	1125	600	1015	1030	600	30.0	500	200 x 40
sw-700.101	1125	700	1015	1030	700	31.5	500	200 x 40
sw-800.101	1325	800	1015	1230	800	36.5	500	200 x 40

EasySTOP swivel castors and foot guards for your safety!



Double-end trolley with mesh

Article no.	Dimension mm			Loading surface mm		Weight kg	Load cap. kg	Wheel diam. mm
	w	D	H	w	d			
sw-500.201	1040	500	975	850	500	30.5	400	160 x 40
sw-600.201	1190	600	1015	1000	600	36.0	500	200 x 40
sw-700.201	1190	700	1015	1000	700	38.5	500	200 x 40
sw-800.201	1390	800	1015	1200	800	45.0	500	200 x 40

EasySTOP swivel castors and foot guards for your safety!

Three-sided trolley with mesh

Article no.	Dimension mm			Loading surface mm		Weight kg	Load cap. kg	Wheel diam. mm
	w	D	H	w	d			
sw-500.301	1040	500	975	850	475	32.0	400	160 x 40
sw-600.301	1190	600	1015	1000	575	38.0	500	200 x 40
sw-700.301	1190	700	1015	1000	675	41.5	500	200 x 40
sw-800.301	1390	800	1015	1200	775	47.5	500	200 x 40

EasySTOP swivel castors and foot guards for your safety!



Four-sided trolley with mesh

Article no.	Dimension mm			Loading surface mm		Weight kg	Load cap. kg	Wheel diam. mm
	w	D	H	w	d			
sw-500.401	1040	500	975	850	450	37.0	400	160 x 40
sw-600.401	1190	600	1015	1000	550	42.5	500	200 x 40
sw-700.401	1190	700	1015	1000	650	45.0	500	200 x 40
sw-800.401	1390	800	1015	1200	750	53.0	500	200 x 40

EasySTOP swivel castors and foot guards for your safety!



Heavy-duty trolleys



Heavy-duty trolleys

Modular system; Base structure with innovative frame section; Load surface, end and side walls of waterproof bonded plywood, surface finish screen printed, anti-slip; Side walls 500 mm high and removable; Trolleys powder-coated RAL 5010 gentian blue; Permanent surface protection; Impact- and scratch-resistant; Elastic solid-rubber tyres on cast aluminium wheel rim with precision deepgroove ball bearings with foot guard; 2 **EasySTOP** swivel castors and 2 fixed castors.

Single-end trolley with screen printing plate

Article no.	Dimension			Loading surface		Weight	Load cap.	Wheel diam.
	w	mm D	H	w	mm d			
sw-700.182	1130	700	1015	1025	700	38.5	1000	200 x 50
sw-800.182	1330	800	1015	1225	800	47.5	1000	200 x 50
sw-800.183	1730	800	1015	1625	800	54.5	1000	200 x 50
sw-800.185	2130	800	1015	2025	800	62.0	1000	200 x 50

EasySTOP swivel castors and foot guards for your safety!



Double-end trolley with screen printing plate

Article no.	Dimension			Loading surface		Weight	Load cap.	Wheel diam.
	w	mm D	H	w	mm d			
sw-700.212	1195	700	1015	995	700	45.5	1000	200 x 50
sw-800.212	1395	800	1015	1195	800	54.5	1000	200 x 50
sw-800.213	1795	800	1015	1595	800	61.5	1000	200 x 50
sw-800.226	2195	800	1015	1995	800	69.5	1000	200 x 50

EasySTOP swivel castors and foot guards for your safety!



Three-sided trolley with screen printing plate

Article no.	Dimension			Loading surface		Weight	Load cap.	Wheel diam.
	w	mm D	H	w	mm d			
sw-700.322	1195	700	1015	995	665	54.5	1000	200 x 50
sw-800.322	1395	800	1015	1195	765	66.5	1000	200 x 50
sw-800.323	1795	800	1015	1595	765	72.0	1000	200 x 50
sw-800.324	2195	800	1015	1995	765	80.5	1000	200 x 50

EasySTOP swivel castors and foot guards for your safety!



Four-sided trolley with screen printing plate

Article no.	Dimension			Loading surface		Weight	Load cap.	Wheel diam.
	w	mm D	H	w	mm d			
sw-700.465	1195	700	1015	995	650	58.5	1000	200 x 50
sw-800.465	1395	800	1015	1195	750	71.5	1000	200 x 50
sw-800.299	1795	800	1015	1595	750	82.5	1000	200 x 50
sw-800.466	2195	800	1015	1995	750	94.5	1000	200 x 50

EasySTOP swivel castors and foot guards for your safety!

Heavy-duty trolleys

Heavy-duty trolleys

Modular system; Welded steel construction; With or without waterproof bonded plywood base, surface finish screen printed, anti-slip; End and side walls with vertical tubes; End walls with horizontal push bar; Height of end and side walls: 800 mm; Side walls removable; Plug-in stanchion; Length of stanchion: 625 mm; Trolleys powder-coated RAL 5010 gentian blue; Permanent surface protection; Impact- and scratch-resistant; Grey non-marking thermoplastic rubber tyres on plastic wheel rim with precision deepgroove ball bearings; Thread guard and foot guard; 2 swivel castors with brakes and 2 fixed castors; 1,200 kg carrying capacity: Elastic solid-rubber tyres on cast aluminium wheel rim with precision deepgroove ball bearings with foot guard; 2 swivel castors with brakes and 2 fixed castors.

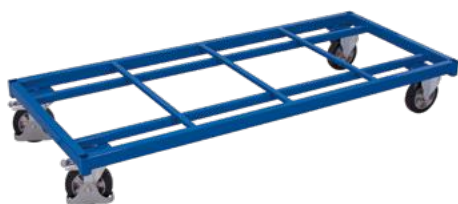

Heavy-duty trolley

Article no.		Dimension			Loading surface		Weight kg	Load cap. kg	Wheel diam. mm
		W	mm D	H	w mm	d			
zu-1225	TR	1380	880	305	1380	880	42.0	500	200 x 40
zu-1226	ER	1380	880	305	1380	880	47.0	1200	200 x 50
zu-1227	TR	1680	880	305	1680	880	49.5	500	200 x 40
zu-1228	ER	1680	880	305	1680	880	53.0	1200	200 x 50
zu-1229	TR	2080	880	305	2080	880	55.5	500	200 x 40
zu-1230	ER	2080	880	305	2080	880	60.5	1200	200 x 50

Swivel castors with wheel brakes and foot guards for your safety!
TR = Thermoplastic rubber tyres, ER = Elastic solid-rubber tyres



Stanchion trolley

Article no.		Dimension			Loading surface		Weight kg	Load cap. kg	Wheel diam. mm
		W	mm D	H	w mm	d			
sw-1310	TR	1380	880	930	1380	805	47.5	500	200 x 40
sw-1300	ER	1380	880	930	1380	805	52.0	1200	200 x 50
sw-1610	TR	1680	880	930	1680	805	53.0	500	200 x 40
sw-1600	ER	1680	880	930	1680	805	57.0	1200	200 x 50
sw-2010	TR	2080	880	930	2080	805	62.5	500	200 x 40
sw-2000	ER	2080	880	930	2080	805	67.0	1200	200 x 50

Swivel castors with wheel brakes and foot guards for your safety!
TR = Thermoplastic rubber tyres, ER = Elastic solid-rubber tyres

Single-end trolley with vertical tubes

Article no.		Dimension			Loading surface		Weight kg	Load cap. kg	Wheel diam. mm
		W	mm D	H	w mm	d			
sw-1312	TR	1475	900	1105	1345	880	59.5	500	200 x 40
sw-1302	ER	1475	900	1105	1345	880	64.0	1200	200 x 50
sw-1612	TR	1775	900	1105	1645	880	67.5	500	200 x 40
sw-1602	ER	1775	900	1105	1645	880	72.0	1200	200 x 50
sw-2012	TR	2175	900	1105	2045	880	82.0	500	200 x 40
sw-2002	ER	2175	900	1105	2045	880	86.5	1200	200 x 50

Swivel castors with wheel brakes and foot guards for your safety!
TR = Thermoplastic rubber tyres, ER = Elastic solid-rubber tyres



Double-end trolley with vertical tubes

Article no.		Dimension			Loading surface		Weight kg	Load cap. kg	Wheel diam. mm
		W	mm D	H	w mm	d			
sw-1313	TR	1575	900	1105	1305	880	68.0	500	200 x 40
sw-1303	ER	1575	900	1105	1305	880	72.5	1200	200 x 50
sw-1613	TR	1875	900	1105	1605	880	76.0	500	200 x 40
sw-1603	ER	1875	900	1105	1605	880	80.5	1200	200 x 50
sw-2013	TR	2275	900	1105	2005	880	90.5	500	200 x 40
sw-2003	ER	2275	900	1105	2005	880	95.0	1200	200 x 50

Swivel castors with wheel brakes and foot guards for your safety!
TR = Thermoplastic rubber tyres, ER = Elastic solid-rubber tyres



Heavy-duty trolleys and long-goods trolley and dolly

Three-sided trolley with vertical tubes

Article no.		Dimension			Loading surface		Weight kg	Load cap. kg	Wheel diam. mm
		W	mm D	H	w mm	d			
sw-1317	TR	1575	900	1105	1305	845	78.0	500	200 x 40
sw-1307	ER	1575	900	1105	1305	845	82.0	1200	200 x 50
sw-1617	TR	1875	900	1105	1605	845	86.5	500	200 x 40
sw-1607	ER	1875	900	1105	1605	845	89.5	1200	200 x 50
sw-2017	TR	2275	900	1105	2005	845	96.0	500	200 x 40
sw-2007	ER	2275	900	1105	2005	845	99.5	1200	200 x 50

Swivel castors with wheel brakes and foot guards for your safety!
TR = Thermoplastic rubber tyres, ER = Elastic solid-rubber tyres



Four-sided trolley with vertical tubes

Article no.		Dimension			Loading surface		Weight kg	Load cap. kg	Wheel diam. mm
		W	mm D	H	w mm	d			
sw-1314	TR	1575	900	1105	1305	810	86.5	500	200 x 40
sw-1304	ER	1575	900	1105	1305	810	90.5	1200	200 x 50
sw-1614	TR	1875	900	1105	1605	810	95.0	500	200 x 40
sw-1604	ER	1875	900	1105	1605	810	97.5	1200	200 x 50
sw-2014	TR	2275	900	1105	2005	810	104.5	500	200 x 40
sw-2004	ER	2275	900	1105	2005	810	108.0	1200	200 x 50

Swivel castors with wheel brakes and foot guards for your safety!
TR = Thermoplastic rubber tyres, ER = Elastic solid-rubber tyres



Long-goods trolley

Welded steel construction; With push-fit tubular steel stanchions; Fill height of the stanchions: 610 mm; Clear depth between the stanchions: 615 mm; 2 material recesses; Centre free for loading by crane or stacker truck; Trolleys powder-coated RAL 5010 gentian blue; Permanent surface protection; Impact- and scratch-resistant; 2 centre wheels of elastic solid-rubber or polyurethane wheels 360 x 60 mm; Plus 1 swivel castor at each end wall with wheel brake, diameter 200 x 50 mm; Elastic solid-rubber or polyurethane tyres with precision deepgroove ball bearings with foot guard.



Long-goods trolley with 4 stanchions

Article no.		Dimension			Loading surface		Fill height mm	Weight kg	Load cap. kg	Wheel diam. mm
		W	mm D	H	w mm	d				
sw-2500	ER	2500	760	1030	2500	615	610	115.0	2000	360 x 60/ 200 x 50
sw-2501	PO	2500	760	1030	2500	615	610	123.0	3000	360 x 60/ 200 x 50

Swivel castors with wheel brakes and foot guards for your safety!
ER = Elastic solid-rubber tyres, PO = Polyurethane wheels

Long-goods dolly

Welded steel construction; With push-fit tubular steel stanchions; Fill height of the stanchions: 610 mm; Clear width between the stanchions: 625 mm; Load surface of waterproof bonded plywood, surface finish screen printed; Dolly powder-coated RAL 5010 gentian blue; Permanent surface protection; Impact- and scratch-resistant; Elastic solid-rubber tyres on cast aluminium wheel rim with precision deepgroove ball bearings with foot guard; 4 swivel castors including 2 with wheel brake.



Long-goods dolly

Article no.		Dimension			Loading surface		Fill height mm	Weight kg	Load cap. kg	Wheel diam. mm
		W	mm D	H	w mm	d				
sw-700.710		700	700	940	625	625	610	51.5	1200	200 x 50

Swivel castors with wheel brakes and foot guards for your safety!

Folding push bar trolleys



Folding push bar trolleys

Welded steel construction; Folding push bar, or tubular push bar with transverse strut and dead man's control; Additional handle beneath the push bar; Load surface of wood-based board, surface finish beech; Trolleys powder-coated RAL 5010 gentian blue; Permanent surface protection; Impact- and scratch-resistant; Grey non-marking thermoplastic rubber tyres on plastic wheel rim with precision deepgroove ball bearings; Thread guard and foot guard; 2 **EasySTOP** swivel castors and 2 fixed castors, or 2 swivel castors with dead man's brake and 2 fixed castors.



Brake applied

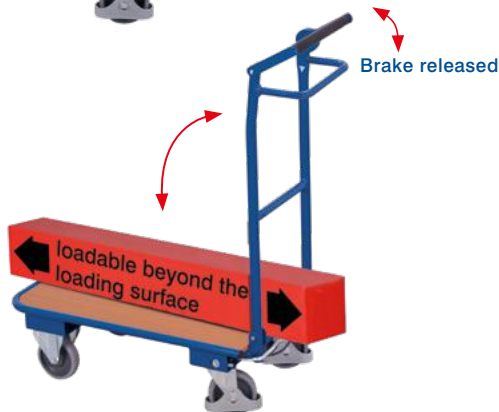

Brake released



Folding push bar trolley

Article no.	Dimension mm			Loading surface mm		Weight kg	Load cap. kg	Wheel diam. mm
	w	D	H	w	d			
sw-450.802	815	450	940	720	450	15.0	150	125 x 32
sw-600.802	995	600	980	900	600	23.5	250	160 x 40

EasySTOP swivel castors and foot guards for your safety!

Folding push bar trolley with dead man's brake

Article no.	Dimension mm			Loading surface mm		Weight kg	Load cap. kg	Wheel diam. mm
	w	D	H	w	d			
sw-450.831	865	450	1005	720	450	17.5	150	125 x 32

Swivel castors with dead man's brake and foot guards for your safety!



Folding push bar trolley with 2 push bars

Article no.	Dimension mm			Loading surface mm		Weight kg	Load cap. kg	Wheel diam. mm
	w	D	H	w	d			
sw-450.803	850	450	940	720	450	18.5	150	125 x 32
sw-600.812	1030	600	980	900	600	27.0	250	160 x 40

EasySTOP swivel castors and foot guards for your safety!

Folding push bar trolley with 2 shelves

Welded steel construction; Folding push bars with transverse strut and folding shelf; Upper shelf lockable in folded state; Lower load surface also usable with shelf folded; Load surface of wood-based board, surface finish beech; Trolley powder-coated RAL 5010 gentian blue; Permanent surface protection; Impact- and scratch-resistant; Grey non-marking thermoplastic rubber tyres on plastic wheel rim with precision deepgroove ball bearings; Thread guard and foot guard; 2 **EasySTOP** swivel castors and 2 fixed castors.



Folding push bar trolley with 2 shelves

Article no.	Dimension mm			Loading surface mm		Weight kg	Load cap. kg	Wheel diam. mm
	w	D	H	w	d			
sw-450.836	890	450	970	720	450	28.0	150	125 x 32

Load capacity shelf: 70 kg*

EasySTOP swivel castors and foot guards for your safety!



*Static distributed load; Total load of the transport device must not be exceeded!





Aluminium folding push bar trolley

Welded aluminium construction; Folding push bar; Transverse strut in push bar; Load surface of diamond-tread plate; Alternative pastet with 3 mm grooved rubber mat, black; Grey non-marking thermoplastic rubber tyres on plastic wheel rim with precision deepgroove ball bearings; Thread guard and foot guard; 2 **EasySTOP** swivel castors and 2 fixed castors.



Aluminium folding push bar trolley

Article no.	Dimension			Loading surface		Weight	Load cap.	Wheel diam.
	mm	mm	mm	mm	mm			
	W	D	H	w	d	kg	kg	mm
ap-450.803	815	450	950	720	450	10.0	150	125 x 32
ap-600.803	995	600	990	900	600	17.5	150	160 x 40

EasySTOP swivel castors and foot guards for your safety!

All folding push bar trolleys have no protruding edges on the load surfaces and can therefore be loaded beyond the edges



Aluminium folding push bar trolley with grooved rubber mat

Article no.	Dimension			Loading surface		Weight	Load cap.	Wheel diam.
	mm	mm	mm	mm	mm			
	W	D	H	w	d	kg	kg	mm
ap-450.810	815	450	950	720	450	12.0	150	125 x 32
ap-600.812	995	600	990	900	600	19.0	150	160 x 40

EasySTOP swivel castors and foot guards for your safety!

Aluminium folding push bar trolley with 2 shelves

Welded aluminium construction; Folding push bars with transverse strut and folding shelf; Upper shelf lockable in folded state; Lower load surface also usable with shelf folded; Load surface of diamond-tread plate; Grey non-marking thermoplastic rubber tyres on plastic wheel rim with precision deepgroove ball bearings; Thread guard and foot guard; 2 **EasySTOP** swivel castors and 2 fixed castors.



Aluminium folding push bar trolley with 2 shelves

Article no.	Dimension			Loading surface		Weight	Load cap.	Wheel diam.
	mm	mm	mm	mm	mm			
	W	D	H	w	d	kg	kg	mm
ap-450.813	890	450	970	720	450	18.0	150	125 x 32

Load capacity shelf: 70 kg*

EasySTOP swivel castors and foot guards for your safety!

*Static distributed load; Total load of the transport device must not be exceeded!



C+C trolleys

C+C trolleys

Welded steel construction; Trolleys nestable; Load surfaces of wood-based board, surface finish beech or waterproof bonded plywood, surface finish screen printed, anti-slip; Push bar with vertical tubes or 4 side frames; Trolleys powder-coated RAL 5010 gentian blue; Permanent surface protection; Impact- and scratch-resistant; Grey non-marking thermoplastic rubber tyres on plastic wheel rim with precision deepgroove ball bearings; Thread guard and foot guard; 2 swivel castors with brakes and 2 fixed castors.



Hang-on wire basket on page 225

C+C trolley

Article no.	Dimension mm			Loading surface mm		Weight kg	Load cap. kg	Wheel diam. mm
	W	D	H	w	d			
sw-500.108	990	640	965	880	500	28.5	400	160 x 40
sw-700.108	1140	840	1005	1030	700	35.5	500	200 x 40

Swivel castors with wheel brakes and foot guards for your safety!



C+C trolley with load surface of screen printing plate

Article no.	Dimension mm			Loading surface mm		Weight kg	Load cap. kg	Wheel diam. mm
	W	D	H	w	d			
sw-500.111	990	640	965	880	500	28.5	400	160 x 40
sw-600.111	1140	740	1005	1030	600	33.0	500	200 x 40
sw-700.111	1140	840	1005	1030	700	38.5	500	200 x 40

Swivel castors with wheel brakes and foot guards for your safety!



C+C trolley with 2 load surfaces of screen printing plate

Article no.	Dimension mm			Loading surface mm		Weight kg	Load cap. kg	Wheel diam. mm
	W	D	H	w	d			
sw-500.112	990	640	965	880	500	36.5	400	160 x 40
sw-600.112	1140	740	1005	1030	600	43.0	500	200 x 40
sw-700.120	1140	840	1005	1030	700	50.0	500	200 x 40

Load capacity shelf: 80 kg*

Swivel castors with wheel brakes and foot guards for your safety!



C+C trolley with 4 side frames

Article no.	Dimension mm			Loading surface mm		Weight kg	Load cap. kg	Wheel diam. mm
	W	D	H	w	d			
sw-500.114	950	640	955	880	445	29.0	400	160 x 40
sw-600.114	1100	740	995	1030	545	32.5	500	200 x 40
sw-700.121	1100	840	995	1030	645	34.0	500	200 x 40

Swivel castors with wheel brakes and foot guards for your safety!

*Static distributed load; Total load of the transport device must not be exceeded!



Customizing



VARIOfit

Customizing comparison

VARIOfit

Box trolleys



Box trolleys

Modular system; Base structure with innovative frame section; Load surface of wood-based board, surface finish beech; End and side walls of wood-based board, surface finish beech or of mesh with size 50 x 50 mm; Height of end and side walls: 200 mm; End and side walls individually removable; Trolleys powder-coated RAL 5010 gentian blue; Permanent surface protection; Impact- and scratch-resistant; Grey non-marking thermoplastic rubber tyres on plastic wheel rim with precision deepgroove ball bearings; Thread guard and foot guard; 2 **EasySTOP** swivel castors and 2 fixed castors.

Box trolley with board panels

Article no.	Dimension			Loading surface		Weight	Load cap.	Wheel diam.
	W	D	H	w	d			
sw-500.402	975	500	975	860	450	30.5	400	160 x 40
sw-600.402	1125	600	1015	1010	550	35.0	500	200 x 40
sw-700.402	1125	700	1015	1010	650	39.5	500	200 x 40
sw-800.402	1325	800	1015	1210	750	45.5	500	200 x 40

EasySTOP swivel castors and foot guards for your safety!

Box trolley with mesh

Article no.	Dimension			Loading surface		Weight	Load cap.	Wheel diam.
	W	D	H	w	d			
sw-500.457	975	500	975	860	450	29.0	400	160 x 40
sw-600.457	1125	600	1015	1010	550	33.0	500	200 x 40
sw-700.457	1125	700	1015	1010	650	37.0	500	200 x 40
sw-800.457	1325	800	1015	1210	750	43.0	500	200 x 40

EasySTOP swivel castors and foot guards for your safety!

Box trolleys

Modular system; Base structure with innovative frame section; Load surface of wood-based board, surface finish beech; End and side walls of wood-based board, surface finish beech or of mesh with size 50 x 50 mm; Height of end and side walls: 710 mm; With flap-down half wall on one side; Trolleys powder-coated RAL 5010 gentian blue; Permanent surface protection; Impact- and scratch-resistant; Grey non-marking thermoplastic rubber tyres on plastic wheel rim with precision deepgroove ball bearings; Thread guard and foot guard; 2 **EasySTOP** swivel castors and 2 fixed castors.

Box trolley with board panels

Article no.	Dimension			Loading surface		Weight	Load cap.	Wheel diam.
	W	D	H	w	d			
sw-700.406	1060	715	1095	1000	650	73.0	500	200 x 40
sw-800.406	1260	815	1095	1200	750	84.0	500	200 x 40

EasySTOP swivel castors and foot guards for your safety!

Box trolley with mesh

Article no.	Dimension			Loading surface		Weight	Load cap.	Wheel diam.
	W	D	H	w	d			
sw-700.404	1060	715	1095	1000	650	50.5	500	200 x 40
sw-800.404	1260	815	1095	1200	750	57.0	500	200 x 40

EasySTOP swivel castors and foot guards for your safety!





Box trolleys

Angle-steel construction; Welded; With horizontal tubular push bar; Load surface of wood-based board, surface finish beech; End and side walls of wood-based board, surface finish beech, or of mesh with size 50 x 50 mm; Height of end and side walls: 800 mm; With flap-down half wall on one side; Double-flap lid, lies flat against side; Lockable by device for padlock; Trolleys powder-coated RAL 5010 gentian blue; Permanent surface protection; Impact- and scratch-resistant; Grey non-marking thermoplastic rubber tyres on plastic wheel rim with precision deepgroove ball bearings; Thread guard and foot guard; 2 **EasySTOP** swivel castors and 2 fixed castors.

Box trolley with board panels and lid, welded

Article no.	Dimension			Loading surface		Weight kg	Load cap. kg	Wheel diam. mm
	W	mm D	H	w	mm d			
sw-700.407	1130	730	1150	970	670	82.0	500	200 x 40
sw-800.407	1330	830	1150	1170	770	96.0	500	200 x 40

EasySTOP swivel castors and foot guards for your safety!



Box trolley with mesh and lid, welded

Article no.	Dimension			Loading surface		Weight kg	Load cap. kg	Wheel diam. mm
	W	mm D	H	w	mm d			
sw-700.405	1130	730	1150	975	680	72.0	500	200 x 40
sw-800.405	1330	830	1150	1175	780	77.5	500	200 x 40

EasySTOP swivel castors and foot guards for your safety!



Steel box trolleys

Welded steel construction; With horizontal tubular push bar; Load surface, end and side walls of steel; Height of end and side walls: 810 mm; With flap-down half wall on one side; Without lid or single-flap lid, lies flat against side, with 2 gas pressure springs; Lid lockable by device for padlock; Trolleys powder-coated RAL 5010 gentian blue; Permanent surface protection; Impact- and scratch-resistant; Grey non-marking thermoplastic rubber tyres on plastic wheel rim with precision deepgroove ball bearings; Thread guard and foot guard; 2 **EasySTOP** swivel castors and 2 fixed castors.

Steel box trolley with lid, welded

Article no.	Dimension			Loading surface		Weight kg	Load cap. kg	Wheel diam. mm
	W	mm D	H	w	mm d			
sw-700.415	1165	730	1115	990	690	99.0	500	200 x 40
sw-800.415	1365	830	1115	1190	790	115.0	500	200 x 40

EasySTOP swivel castors and foot guards for your safety!



Steel box trolley, welded

Article no.	Dimension			Loading surface		Weight kg	Load cap. kg	Wheel diam. mm
	W	mm D	H	w	mm d			
sw-700.414	1130	720	1105	990	690	85.5	500	200 x 40
sw-800.414	1330	820	1105	1190	790	101.0	500	200 x 40

EasySTOP swivel castors and foot guards for your safety!

Side-frame trolleys

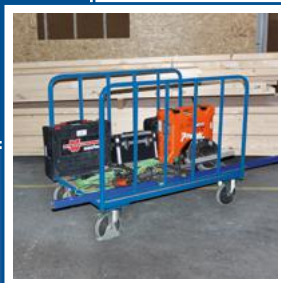

Side-frame trolleys

Modular system; Base structure with innovative frame section; Load surface of wood-based board, surface finish beech; Side walls either of wood-based board, surface finish beech or of mesh with size 50 x 50 mm, or with vertical tubular tubes or with 4 tubular side frames; Trolleys powder-coated RAL 5010 gentian blue; Permanent surface protection; Impact- and scratch-resistant; Grey non-marking thermoplastic rubber tyres on plastic wheel rim with precision deepgroove ball bearings; Thread guard and foot guard; 2 **EasySTOP** swivel castors and 2 fixed castors.



Side-frame trolley with board sides

Article no.	Dimension			Loading surface		Weight kg	Load cap. kg	Wheel diam. mm
	W	mm D	H	w	d			
sw-600.200	1060	600	1045	1060	540	44.5	500	200 x 40
sw-700.200	1060	700	1045	1060	640	46.0	500	200 x 40
sw-800.200	1260	800	1045	1260	740	53.0	500	200 x 40

EasySTOP swivel castors and foot guards for your safety!



Side-frame trolley with mesh sides

Article no.	Dimension			Loading surface		Weight kg	Load cap. kg	Wheel diam. mm
	W	mm D	H	w	d			
sw-600.239	1060	600	1045	1060	540	34.5	500	200 x 40
sw-700.231	1060	700	1045	1060	640	37.5	500	200 x 40
sw-800.237	1260	800	1045	1260	740	49.5	500	200 x 40

EasySTOP swivel castors and foot guards for your safety!

Side-frame trolley with tubular side walls

Article no.	Dimension			Loading surface		Weight kg	Load cap. kg	Wheel diam. mm
	W	mm D	H	w	d			
sw-600.203	1060	600	1045	1060	540	30.5	500	200 x 40
sw-700.203	1060	700	1045	1060	640	33.5	500	200 x 40
sw-800.203	1260	800	1045	1260	740	44.5	500	200 x 40

EasySTOP swivel castors and foot guards for your safety!



Side-frame trolley with 4 tubular side frames

Article no.	Dimension			Loading surface		Weight kg	Load cap. kg	Wheel diam. mm
	W	mm D	H	w	d			
sw-500.204	910	500	990	910	440	30.0	400	160 x 40
sw-600.204	1060	600	1030	1060	540	35.0	500	200 x 40
sw-700.204	1060	700	1030	1060	640	37.0	500	200 x 40
sw-800.204	1260	800	1030	1260	740	43.5	500	200 x 40

EasySTOP swivel castors and foot guards for your safety!



Tubular-support trolley and sheet-material trolley and sheet-material stand



Tubular-support trolley

Modular system; Base structure with innovative frame section; Load surface of wood-based board, surface finish beech; Incl. 2 tubular supports and 2 rows of sockets for 7 tubular supports; Trolley powder-coated RAL 5010 gentian blue; Permanent surface protection; Impact- and scratch-resistant; Grey non-marking thermoplastic rubber tyres on plastic wheel rim with precision deepgroove ball bearings; Thread guard and foot guard; 2 swivel and 2 fixed castors; With central foot brake **EasySTOP** (1 swivel and 1 fixed castor is braked on one longitudinal side).

Tubular-support trolley with 2 tubular supports

Article no.	Dimension			Loading surface		Weight kg	Load cap. kg	Wheel diam. mm
	W	mm D	H	w	mm d			
sw-700.205	1150	700	1040	1075	640	40.5	500	200 x 40
sw-800.205	1350	800	1040	1275	740	47.0	500	200 x 40

EasySTOP swivel castors and foot guards for your safety!

Additional article - Tubular supports

Article no.	for loading surface		Weight kg	Additional tube
	w	mm d		
zsw-700.205	1075	640	5.0	
zsw-800.205	1275	740	5.5	



EasySTOP can also be used when loading long goods



Sheet-material trolley and sheet-material stand

Welded steel construction; Without tubular supports; With one approach roller at end; 7 alternative positions for inserting tubular supports; Clearance between supports 95 mm; Load surface of wood-based board, surface finish beech; Trolley and stand powder-coated RAL 5010 gentian blue; Permanent surface protection; Impact- and scratch-resistant; Grey non-marking thermoplastic rubber tyres on plastic wheel rim with precision deepgroove ball bearings; Thread guard and foot guard; 2 swivel castors with brakes and 2 fixed castors; For 1,200 kg carrying capacity; Elastic solid-rubber tyres on cast aluminium wheel rim with precision deepgroove ball bearings with foot guard; 2 swivel castors with brakes and 2 fixed castors; Sheet-material stand without castors.

Sheet-material trolley (without tubular support)

Article no.		Dimension			Loading surface		Weight kg	Load cap. kg	Wheel diam. mm
		W	mm D	H	w	mm d			
sw-1282	TR	1310	800	310	1200	800	41.5	500	200 x 40
sw-1283	ER	1310	800	310	1200	800	44.5	1200	200 x 50
sw-1284	TR	1710	800	310	1600	800	47.0	500	200 x 40
sw-1285	ER	1710	800	310	1600	800	49.0	1200	200 x 50

Swivel castors with wheel brakes and foot guards for your safety!
TR = Thermoplastic rubber tyres, ER = Elastic solid-rubber tyres



Sheet-material stand (without tubular support)

Article no.	Dimension			Loading surface		Weight kg	Load cap. kg
	W	mm D	H	w	mm d		
zu-1286	1310	800	75	1200	800	33.5	1200
zu-1287	1710	800	75	1600	800	39.5	1200



Additional article - Tubular support for sheet-material trolley/stand

Article no.	Dimension		Weight kg	Tubular support
	W	mm H		
zsw-1290	1200	300	2.5	
zsw-1291	1200	600	3.5	
zsw-1292	1200	900	4.5	
zsw-1293	1600	300	3.0	
zsw-1294	1600	600	4.0	
zsw-1295	1600	900	5.0	

Additional article - Feet for sheet-material stand

Article no.	Ground clearance mm	Weight kg
gzu-1286	100	1.5

Sheet-material trolleys



Sheet-material trolleys

Welded steel construction; Load surface of plywood, tilts to 5°; Height of side tubular support: 915 mm; Trolleys powder-coated RAL 5010 gentian blue; Permanent surface protection; Impact- and scratch-resistant; Grey non-marking thermoplastic rubber tyres on plastic wheel rim with precision deepgroove ball bearings; Thread guard and foot guard; 2 swivel castors with brakes and 2 fixed castors.



Sheet-material trolley

Article no.	Dimension mm			Loading surface mm		Weight kg	Load cap. kg	Wheel diam. mm
	W	D	H	w	d			
pl-150.010	1500	680	1200	1500	370	47.5	500	200 x 40

Swivel castors with wheel brakes and foot guards for your safety!

Information for wheels in rhombic layout on page 218

Sheet-material trolley with rhombic layout

Article no.	Dimension mm			Loading surface mm		Weight kg	Load cap. kg	Wheel diam. mm
	W	D	H	w	d			
pl-150.011	1500	680	1200	1500	370	47.5	500	200 x 40

Swivel castors with wheel brakes and foot guards for your safety!

Sheet-material trolleys, one-sided or two-sided

Welded steel construction; One-sided or two-sided load surface, tilts to 5°; Sheet supports faced with rubber profile; Base support width for one-sided layout: 430 mm, for two-sided layout: 2 x 270 mm; Trolleys powder-coated RAL 5010 gentian blue; Permanent surface protection; Impact- and scratch-resistant; Elastic solid-rubber tyres on cast aluminium wheel rim with precision deepgroove ball bearings with foot guard; 2 swivel castors with brakes and 2 fixed castors.

Sheet-material trolley, one-sided

Article no.	Dimension mm			Loading surface mm		Weight kg	Load cap. kg	Wheel diam. mm
	W	D	H	w	d			
sw-1305	1380	880	1700	1380	430	53.5	1200	200 x 50
sw-1605	1680	880	1700	1680	430	64.0	1200	200 x 50
sw-2005	2080	880	1700	2080	430	81.5	1200	200 x 50

Swivel castors with wheel brakes and foot guards for your safety!



Sheet-material trolley, two-sided

Article no.	Dimension mm			Loading surface mm		Weight kg	Load cap. kg	Wheel diam. mm
	W	D	H	w	d			
sw-1306	1380	880	1705	1380	2 x 270	59.0	1200	200 x 50
sw-1606	1680	880	1705	1680	2 x 270	70.0	1200	200 x 50
sw-2006	2080	880	1705	2080	2 x 270	87.0	1200	200 x 50

Swivel castors with wheel brakes and foot guards for your safety!



Sheet-material trucks



Sheet-material trucks

Welded tubular steel construction; Sheet-steel platform; Toe plate sloping towards supporting frame, welded to substructure; Tilt 22°; For lengthways transport of large wood and plastic panels; Trucks powder-coated RAL 5010 gentian blue; Permanent surface protection; Impact- and scratch-resistant; Pneumatic tyres on steel wheel rim or solid-rubber tyres on special plastic wheel rim with precision deepgroove ball bearings and plastic wheel cap, plus 2 support rollers; Also available: Version with variable panel retainer; For panel stack max. 200 x 1,500 mm (D/H).



Sheet-material truck

Article no.		Dimension mm			Toe plate mm		Weight kg	Load cap. kg	Wheel diam. mm
		W	D	H	w	d			
sk-710.035	P	1260	680	1425	500	200	18.5	250	260 x 85
sk-710.036	SR	1260	680	1425	500	200	20.0	250	260 x 65

P = Pneumatic tyres, SR = Solid-rubber tyres

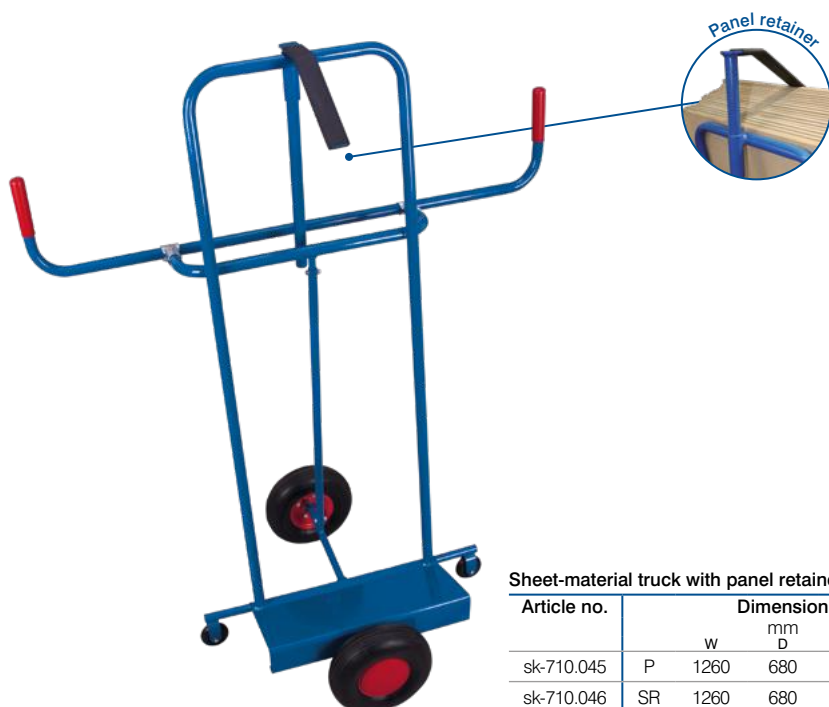

Sheet-material truck with panel retainer

Article no.		Dimension mm			Toe plate mm		Weight kg	Load cap. kg	Wheel diam. mm
		W	D	H	w	d			
sk-710.045	P	1260	680	1440	500	200	20.0	250	260 x 85
sk-710.046	SR	1260	680	1440	500	200	21.5	250	260 x 65

P = Pneumatic tyres, SR = Solid-rubber tyres

Workpiece trolleys



Workpiece trolleys

Modular system; Base structure with innovative frame section; Load surface of wood-based board, surface finish beech; Screwed superstructure made of angle steel with welded mesh 75 x 75 mm; Height of superstructure 1,260 mm; Slope of grid 8%; Usable load surface 2 x 1,260 x 245 mm; Usable load surface of top shelf: 1,185 x 265 mm; Top shelf of wood-based board, surface finish beech; Load surface edge 15 mm high; Trolleys powder-coated RAL 5010 gentian blue; Permanent surface protection; Impact- and scratch-resistant; Grey non-marking thermoplastic rubber tyres on plastic wheel rim with precision deepgroove ball bearings; Thread guard and foot guard; 2 **EasySTOP** swivel castors and 2 fixed castors.

Workpiece trolley

Article no.	Dimension mm			Loading surface mm		Weight kg	Load cap. kg	Wheel diam. mm
	w	D	H	w	d			
sw-800.800	1370	800	1560	1260	2 x 245	89.5	500	200 x 40

EasySTOP swivel castors and foot guards for your safety!



Workpiece trolley with top shelf

Article no.	Dimension mm			Loading surface mm		Weight kg	Load cap. kg	Wheel diam. mm
	w	D	H	w	d			
sw-800.801	1370	800	1585	1260	2 x 245	97.5	500	200 x 40

Load capacity shelf: 50 kg*

EasySTOP swivel castors and foot guards for your safety!



Additional article - Bar for slide down safety

Article no.	Piece	Dimension mm		Weight kg
		w	H	
gsw-800.203.1	2	1260	100	3.5

*Static distributed load; Total load of the transport device must not be exceeded!



Additional articles

Additional article - Thorn bracket

Article no.	Dimension		Weight kg	Load cap. kg
	mm			
zsw-800.800	10 diam. × 210		0.3	10
zsw-800.801	10 diam. × 310		0.4	10



Additional article - Pipe carrier

Article no.	Dimension		Weight kg	Load cap. kg
	mm			
zsw-800.802	16 diam. × 305		0.4	15
zsw-800.803	22 diam. × 305		0.5	25
zsw-800.804	27 diam. × 305		0.6	25



Additional article - Corrugated bracket

Article no.	Dimension		Weight kg	Load cap. kg
	mm			
zsw-800.805	320		0.8	25



Additional article - Fork bracket

Article no.	Dimension		Weight kg	Load cap. kg
	mm			
zsw-800.806	50 × 295		0.8	25



Additional article - Material box

Article no.	Dimension			Weight kg	Load cap. kg
	w	mm D	H		
zsw-800.807	265	150	110	1.5	25
zsw-800.808	1200	265	110	4.5	50



Additional article - Material crate

Article no.	Dimension			Weight kg	Colour
	w	mm D	H		
fk-105.000	105	85	45	0.1	green



Additional article - Material crate

Article no.	Dimension			Weight kg	Colour
	w	mm D	H		
fk-105.001	105	160	75	0.2	yellow



Additional article - Material crate

Article no.	Dimension			Weight kg	Colour
	w	mm D	H		
fk-140.000	140	230	130	0.3	red



Additional article - Material crate

Article no.	Dimension			Weight kg	Colour
	w	mm D	H		
fk-140.001	140	290	130	0.4	blue

Carrier-spar trolleys

Carrier-spar trolleys

Welded tubular steel construction; 4 or 8 carrier spars per upright; Circa carrier-spar length 595 mm (one-sided) and 375 mm (two-sided); Width of trolley continuously adjustable; Height of carrier-spars continuously adjustable; Scale for adjusting arrangement of carrier-spars; Load capacity per carrier-spar 20 kg; Trolleys powder-coated RAL 5010 gentian blue; Permanent surface protection; Impact- and scratch-resistant; Grey non-marking thermoplastic rubber tyres on plastic wheel rim with precision deepgroove ball bearings; Thread guard and foot guard; 2 swivel castors with brakes and 2 swivel castors, 1 of them with direction lock.



Carrier-spar trolley, one-sided

Article no.		Dimension			Weight kg	Load cap. kg	Wheel diam. mm
		W	mm D	H			
sw-130.006	one-sided	540-1400	800	1800	49.0	400	160 x 40
sw-160.006	one-sided	540-1700	800	1800	50.5	400	160 x 40

Load capacity carrier-spar arm: 20 kg*

Swivel castors with wheel brake and foot guards for your safety!

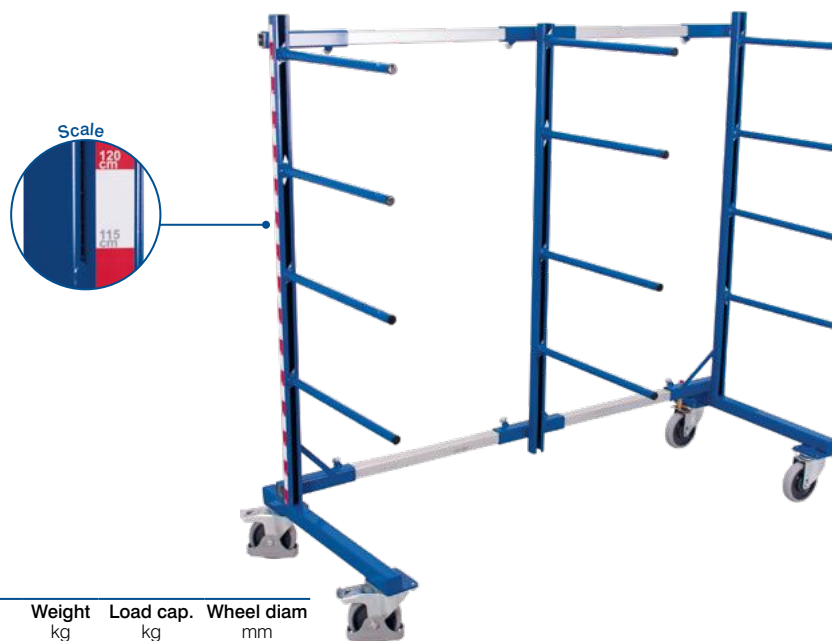

Carrier-spar trolley, one-sided

Article no.		Dimension			Weight kg	Load cap. kg	Wheel diam. mm
		W	mm D	H			
sw-210.006	one-sided	840-2200	800	1800	72.5	400	160 x 40
sw-310.006	one-sided	840-3200	800	1800	76.5	400	160 x 40

Load capacity carrier-spar arm: 20 kg*

Swivel castors with wheel brake and foot guards for your safety!

Additional articles - Carrier-spars and slip off safety

Article no.	Dimension mm		Load cap. kg
zsw-596.000	595 mm x 3/4"	Carrier-spar	20
zsw-596.001	595 mm x 3/4"	Carrier-spar with shrink hose	20
zsw-596.002	1 mm	Shrink hose	-
zsw-596.003	595 mm x 3/4"	Carrier-spar with slip off safety	20
zsw-070.000	diam. 70 mm	Slip off safety	-
zsw-596.004	595 mm x 3/4"	Carrier-spar with shrink hose and anti-roll devices	20



*Total load of the transport device must not be exceeded!



Carrie-spar trolley, two-sided

Article no.		Dimension			Weight kg	Load cap. kg	Wheel diam. mm
		w	mm D	H			
sw-130.007	two-sided	540-1400	830	1800	57.0	400	160 x 40
sw-160.007	two-sided	540-1700	830	1800	59.0	400	160 x 40

Load capacity carrier-spar arm: 20 kg*
Swivel castors with wheel brake and foot guards for your safety!



Carrie-spar trolley, two-sided

Article no.		Dimension			Weight kg	Load cap. kg	Wheel diam. mm
		w	mm D	H			
sw-210.007	two-sided	840-2200	830	1800	80.0	400	160 x 40
sw-310.007	two-sided	840-3200	830	1800	84.0	400	160 x 40

Load capacity carrier-spar arm: 20 kg*
Swivel castors with wheel brake and foot guards for your safety!



Additional articles - Carrier-spars and slip off safety

Article no.	Dimension mm		Load cap. kg
zsw-376.000	375 mm x 3/4"	Carrier-spar	20
zsw-376.001	375 mm x 3/4"	Carrier-spar with shrink hose	20
zsw-376.002	1 mm	Shrink hose	-
zsw-376.003	375 mm x 3/4"	Carrier-spar with slip off safety	20
zsw-070.000	diam. 70 mm	Slip off safety	-
zsw-376.004	375 mm x 3/4"	Carrier-spar with shrink hose and anti-roll devices	20

*Total load of the transport device must not be exceeded!



Light table trolleys

Light table trolleys

Modular system; Base structure with innovative frame section; Load surfaces of wood-based board, surface finish beech; Set in angle-steel frame, edge = 15 mm high; 2 lockable drawers, extractable until 70%; Inside dimensions of the drawers: 400 x 450 x 80 mm (W/D/H); Load capacity per drawer: 25 kg; Trolleys powder-coated RAL 5010 gentian blue; Permanent surface protection; Impact- and scratch-resistant; Grey non-marking thermoplastic rubber tyres on plastic wheel rim with precision deepgroove ball bearings; Thread guard and foot guard; 2 **EasySTOP** swivel castors and 2 fixed castors.



Table trolley with 2 load surfaces

Article no.	Dimension			Loading surface		Weight	Load cap.	Wheel diam.
	W	D	H	w	d			
sw-500.501	1025	525	850	835	490	28.0	250	125 x 32
sw-600.501	1175	625	850	985	590	33.5	250	125 x 32

Load capacity shelf: 80 kg*
EasySTOP swivel castors and foot guards for your safety!

Table trolley with 3 load surfaces

Article no.	Dimension			Loading surface		Weight	Load cap.	Wheel diam.
	W	D	H	w	d			
sw-500.603	1025	525	850	835	490	37.0	250	125 x 32
sw-600.601	1175	625	850	985	590	44.5	250	125 x 32

Load capacity shelf: 80 kg*
EasySTOP swivel castors and foot guards for your safety!



Also available in ESD design on page 106

Inside dimension drawer:
W=400 x D=450 x H=80 mm (2x)

Suitable drawer divider set (zsw-600.604) on page 114

Table trolley with 2 load surfaces and 2 drawers

Article no.	Dimension			Loading surface		Weight	Load cap.	Wheel diam.
	W	D	H	w	d			
sw-600.504	1175	625	850	985	590	46.0	250	125 x 32

Load capacity shelf: 80 kg*
EasySTOP swivel castors and foot guards for your safety!



*Static distributed load; Total load of the transport device must not be exceeded!



VARIOfit



Also available in ESD design on page 102

Table trolley with 2 load surfaces

Article no.	Dimension			Loading surface		Weight	Load cap.	Wheel diam.
	W	mm D	H	w	mm d			
sw-500.500	975	525	1010	835	490	28.5	250	125 x 32
sw-600.500	1125	625	1010	985	590	34.0	250	125 x 32

Load capacity shelf: 80 kg*
EasySTOP swivel castors and foot guards for your safety!



Also available in ESD design on page 102

Table trolley with 3 load surfaces

Article no.	Dimension			Loading surface		Weight	Load cap.	Wheel diam.
	W	mm D	H	w	mm d			
sw-500.600	975	525	1010	835	490	37.5	250	125 x 32
sw-600.600	1125	625	1010	985	590	45.0	250	125 x 32

Load capacity shelf: 80 kg*
EasySTOP swivel castors and foot guards for your safety!



Also available in ESD design on page 106

Suitable drawer divider set (zsw-600.604) on page 114

Inside dimension drawer:
W=400 x D=450 x H=80 mm (2x)

Table trolley with 2 load surfaces and 2 drawers

Article no.	Dimension			Loading surface		Weight	Load cap.	Wheel diam.
	W	mm D	H	w	mm d			
sw-600.503	1125	625	1010	985	590	46.0	250	125 x 32

Load capacity shelf: 80 kg*
EasySTOP swivel castors and foot guards for your safety!



Dead man's brake

Table trolley with dead man's brake

Base structure with innovative frame section; Tubular push bar with dead man's control; Additional handle beneath the push bar; Load surfaces of wood-based board, surface finish beech; Set in angle-steel frame, edge = 15 mm high; Trolley powder-coated RAL 5010 gentian blue; Permanent surface protection; Impact- and scratch-resistant; Grey non-marking thermoplastic rubber tyres on plastic wheel rim with precision deepgroove ball bearings; Thread guard and foot guard; 2 swivel castors with dead man's brake and 2 fixed castors.

Table trolley with 2 load surfaces and dead man's brake

Article no.	Dimension			Loading surface		Weight	Load cap.	Wheel diam.
	W	mm D	H	w	mm d			
sw-600.548	1175	625	1045	985	590	37.5	250	125 x 32

Load capacity shelf: 80 kg*
Swivel castors with dead man's brake and foot guards for your safety!

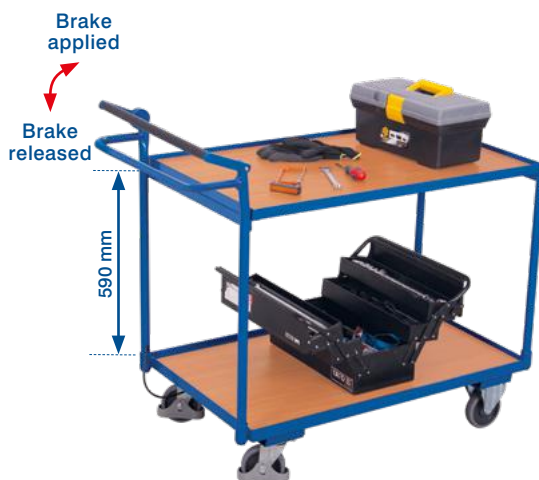

*Static distributed load; Total load of the transport device must not be exceeded!



Order-picking trolleys

Order-picking trolleys

Welded steel construction; Base structure with innovative frame section; Load surfaces of wood-based board, surface finish beech; Set in angle-steel frame, edge = 15 mm high; Step treads of waterproof bonded plywood, surface finish screen printed, anti-slip; Steps lift automatically in the unloaded condition via a gas spring strut; Trolleys powder-coated RAL 5010 gentian blue; Permanent surface protection; Impact- and scratch-resistant; Grey non-marking thermoplastic rubber tyres on plastic wheel rim with precision deepgroove ball bearings; Thread guard and foot guard; 2 swivel castors with brakes and 2 fixed castors.



Order-picking trolley with 2 shelves, low

Article no.	Dimension mm			Loading surface mm		Weight kg	Load cap. kg	Wheel diam. mm
	w	D	H	w	d			
sw-600.614	1455	625	1320	985	590	40.0	250	125 x 32
shelf heights 185 / 805 mm height of top step 500 mm step height 230 mm								
Load capacity shelf: 80 kg* Swivel castors with wheel brakes and foot guards for your safety!								



Order-picking trolley with 3 shelves, low

Article no.	Dimension mm			Loading surface mm		Weight kg	Load cap. kg	Wheel diam. mm
	w	D	H	w	d			
sw-600.615	1455	625	1320	985	590	50.0	250	125 x 32
shelf heights 185 / 490 / 805 mm height of top step 500 mm step height 230 mm								
Load capacity shelf: 80 kg* Swivel castors with wheel brakes and foot guards for your safety!								

Order-picking trolley with 3 shelves, high

Article no.	Dimension mm			Loading surface mm		Weight kg	Load cap. kg	Wheel diam. mm
	w	D	H	w	d			
sw-600.616	1695	625	1900	985	590	64.5	250	160 x 40
shelf heights 225 / 845 / 1465 mm height of top step 980 mm step height 230 mm								
Load capacity shelf: 80 kg* Swivel castors with wheel brakes and foot guards for your safety!								



Order-picking trolley with 4 shelves, high

Article no.	Dimension mm			Loading surface mm		Weight kg	Load cap. kg	Wheel diam. mm
	w	D	H	w	d			
sw-600.617	1695	625	1900	985	590	77.0	250	160 x 40
shelf heights 225 / 695 / 1170 / 1645 mm height of top step 980 mm step height 230 mm								
Load capacity shelf: 80 kg* Swivel castors with wheel brakes and foot guards for your safety!								



*Static distributed load; Total load of the transport device must not be exceeded!

Table trolleys



Table trolleys

Modular system; Base structure with innovative frame section; Load surfaces of wood-based board, surface finish beech; Load surfaces flush with frame; Upper shelf replaceable; Trolleys powder-coated RAL 5010 gentian blue; Permanent surface protection; Impact- and scratch-resistant; Grey non-marking thermoplastic rubber tyres on plastic wheel rim with precision deepgroove ball bearings; Thread guard and foot guard; 2 **EasySTOP** swivel castors and 2 fixed castors.



Table trolley with 2 load surfaces

Article no.	Dimension			Loading surface		Weight	Load cap.	Wheel diam.
	w	D	H	w	d			
sw-500.502	1045	500	935	850	500	30.0	200	125 x 32
sw-600.502	1195	600	935	1000	600	34.0	200	125 x 32

Load capacity shelf: 80 kg*
EasySTOP swivel castors and foot guards for your safety!



Table trolleys

Welded steel or aluminium construction; Load surfaces of wood-based board, surface finish beech; Edge 20 mm high; Steel table trolley powder-coated RAL 5010 gentian blue; Permanent surface protection; Impact- and scratch-resistant; Grey non-marking thermoplastic rubber tyres on plastic wheel rim with precision deepgroove ball bearings; Thread guard and foot guard; 2 swivel castors with brakes and 2 fixed castors.



Steel table trolley

Article no.	Dimension			Loading surface		Weight	Load cap.	Wheel diam.
	w	D	H	w	d			
st-402.000	1090	600	970	970	570	33.0	200	125 x 32

Load capacity shelf: 100 kg*
Swivel castors with wheel brakes and foot guards for your safety!



Aluminium table trolley

Article no.	Dimension			Loading surface		Weight	Load cap.	Wheel diam.
	w	D	H	w	d			
ap-412.000	1090	600	975	970	570	24.0	200	125 x 32

Load capacity shelf: 100 kg*
Swivel castors with wheel brakes and foot guards for your safety!

*Static distributed load; Total load of the transport device must not be exceeded!

Heavy-duty table trolleys



VARIOfit®



Heavy-duty table trolleys

Modular system; Base structure with innovative frame section; Load surfaces of wood-based board, surface finish beech, or waterproof bonded plywood, surface finish screen printed, anti-slip, or covered with galvanised sheet (folded over load surface); Load surfaces flush with the frame; Trolleys powder-coated RAL 5010 gentian blue; Permanent surface protection; Impact- and scratch-resistant; Grey non-marking thermoplastic rubber tyres on plastic wheel rim with precision deepgroove ball bearings; Thread guard and foot guard, or elastic solid-rubber tyres on cast aluminium wheel rim with precision deepgroove ball bearings with foot guard; 2 **EasySTOP** swivel castors and 2 fixed castors.



Also available in ESD design on page 102

Heavy-duty table trolley with 2 load surfaces

Article no.	Dimension			Loading surface		Weight kg	Load cap. kg	Wheel diam. mm
	W	D	H	w	d			
sw-500.504	1040	500	880	850	500	34.0	400	160 x 40
sw-600.510	1190	600	920	1000	600	40.5	500	200 x 40
sw-700.500	1190	700	920	1000	700	46.0	500	200 x 40
sw-800.500	1390	800	920	1200	800	51.5	500	200 x 40

Load capacity shelf: 200 kg*
EasySTOP swivel castors and foot guards for your safety!



Heavy-duty table trolley with 2 load surfaces

Article no.	Dimension			Loading surface		Weight kg	Load cap. kg	Wheel diam. mm
	W	D	H	w	d			
sw-700.530	1190	700	925	995	700	60.5	1000	200 x 50
sw-800.502	1390	800	925	1195	800	66.5	1000	200 x 50
sw-800.511	1790	800	925	1595	800	82.5	1000	200 x 50
sw-800.514	2190	800	925	1995	800	95.5	1000	200 x 50

Load capacity shelf: 500 kg*
EasySTOP swivel castors and foot guards for your safety!



Heavy-duty table trolley with 2 load surfaces covered with galvanised sheet

Article no.	Dimension			Loading surface		Weight kg	Load cap. kg	Wheel diam. mm
	W	D	H	w	d			
sw-700.505	1190	700	920	1000	700	55.0	500	200 x 40
sw-800.505	1390	800	920	1200	800	65.0	500	200 x 40

Load capacity shelf: 200 kg*
EasySTOP swivel castors and foot guards for your safety!

*Static distributed load; Total load of the transport device must not be exceeded!



Also available in ESD design on page 102

Heavy-duty table trolley with 3 load surfaces

Article no.	Dimension			Loading surface		Weight kg	Load cap. kg	Wheel diam. mm
	W	D	H	w	d			
sw-500.650	1040	500	880	850	500	44.5	400	160 x 40
sw-600.512	1190	600	920	1000	600	54.5	500	200 x 40
sw-700.600	1190	700	920	1000	700	55.5	500	200 x 40
sw-800.600	1390	800	920	1200	800	67.5	500	200 x 40

Load capacity shelf: 200 kg*
EasySTOP swivel castors and foot guards for your safety!



Heavy-duty table trolley with 3 load surfaces

Article no.	Dimension			Loading surface		Weight kg	Load cap. kg	Wheel diam. mm
	W	D	H	w	d			
sw-700.617	1190	700	925	995	700	73.5	1000	200 x 50
sw-800.617	1390	800	925	1195	800	92.0	1000	200 x 50
sw-800.618	1790	800	925	1595	800	105.5	1000	200 x 50
sw-800.619	2190	800	925	1995	800	135.0	1000	200 x 50

Load capacity shelf: 500 kg*
EasySTOP swivel castors and foot guards for your safety!



Heavy-duty table trolley with 4 load surfaces

Article no.	Dimension			Loading surface		Weight kg	Load cap. kg	Wheel diam. mm
	W	D	H	w	d			
sw-700.700	1190	700	1235	1000	700	74.5	500	200 x 40
sw-800.700	1390	800	1235	1200	800	87.5	500	200 x 40

Load capacity shelf: 200 kg*
EasySTOP swivel castors and foot guards for your safety!

*Static distributed load; Total load of the transport device must not be exceeded!



Table trolleys with pan



Table trolleys with pan

Welded steel construction; Screwed; Oil-tight pans and edge = 40 mm high; Trolleys powder-coated RAL 5010 gentian blue; Permanent surface protection; Impact- and scratch-resistant; Grey non-marking thermoplastic rubber tyres on plastic wheel rim with precision deepgroove ball bearings; Thread guard and foot guard; 2 **EasySTOP** swivel castors and 2 fixed castors.

Table trolley with 2 load surfaces

Article no.	Dimension mm			Loading surface mm		Weight kg	Load cap. kg	Wheel diam. mm
	W	D	H	w	d			
sw-500.510	985	500	910	845	495	36.5	400	160 x 40
sw-700.510	1135	700	950	995	695	50.0	400	200 x 40

Load capacity shelf: 100 kg*
EasySTOP swivel castors and foot guards for your safety!

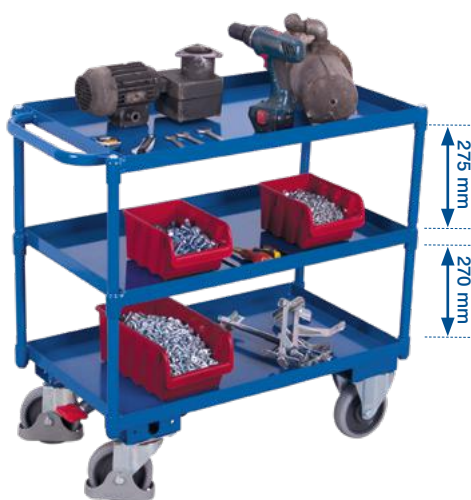

Table trolley with 3 load surfaces

Article no.	Dimension mm			Loading surface mm		Weight kg	Load cap. kg	Wheel diam. mm
	W	D	H	w	d			
sw-500.610	985	500	910	845	495	44.5	400	160 x 40
sw-700.610	1135	700	950	995	695	63.5	400	200 x 40

Load capacity shelf: 100 kg*
EasySTOP swivel castors and foot guards for your safety!

Table trolley with 2 load surfaces

Article no.	Dimension mm			Loading surface mm		Weight kg	Load cap. kg	Wheel diam. mm
	W	D	H	w	d			
sw-500.523	1015	500	1025	845	495	36.5	400	160 x 40
sw-700.523	1165	700	1065	995	695	50.0	400	200 x 40

Load capacity shelf: 100 kg*
EasySTOP swivel castors and foot guards for your safety!



Table trolley with 3 load surfaces

Article no.	Dimension mm			Loading surface mm		Weight kg	Load cap. kg	Wheel diam. mm
	W	D	H	w	d			
sw-500.698	1015	500	1025	845	495	45.0	400	160 x 40
sw-700.623	1165	700	1065	995	695	63.5	400	200 x 40

Load capacity shelf: 100 kg*
EasySTOP swivel castors and foot guards for your safety!



*Static distributed load; Total load of the transport device must not be exceeded!



Table trolleys with pan

Welded steel construction; Screwed; Oil-tight pans and edge = 25 mm high; Alternative with removable steel-sheet pan (113 l), sides 200 mm high and 2 handles, or with screwed drip tray (60 l), incl. galvanised grating, mesh size 30 x 30 mm and conical outlet cock; Top pan 100 mm high; Trolleys powder-coated RAL 5010 gentian blue; Permanent surface protection; Impact- and scratch-resistant; Grey non-marking thermoplastic rubber tyres on plastic wheel rim with precision deepgroove ball bearings; Thread guard and foot guard; 2 **EasySTOP** swivel castors and 2 fixed castors.



Table trolley with 2 load surfaces and removable steel-sheet pan

Article no.	Dimension			Loading surface		Weight	Load cap.	Wheel diam.
	W	D	H	w	d			
sw-600.507	1180	610	1055	995	595	49.5	250	125 x 32

Load capacity shelf: 80 kg*
EasySTOP swivel castors and foot guards for your safety!

Additional article - Removable steel-sheet pan

Article no.	Dimension			Loading surface		Weight	Volume
	W	D	H	w	d		
gsw-600.507	1075	590	235	985	585	12.5	113

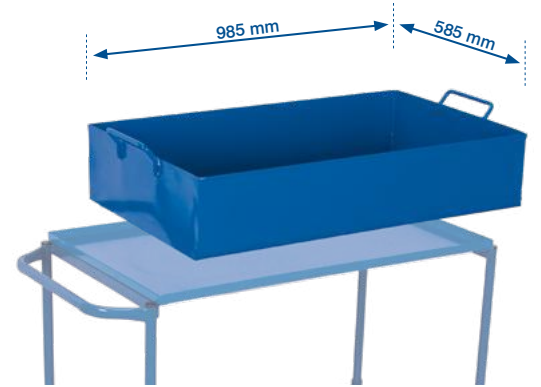

Table trolley with 2 load surfaces

Article no.	Dimension			Loading surface		Weight	Load cap.	Wheel diam.
	W	D	H	w	d			
sw-600.506	1170	610	845	995	595	37.0	250	125 x 32

Load capacity shelf: 80 kg*
EasySTOP swivel castors and foot guards for your safety!



Table trolley with 2 load surfaces and galvanised grating

Article no.	Dimension			Loading surface		Weight	Load cap.	Wheel diam.
	W	D	H	w	d			
sw-600.505	1125	610	1020	995	595	58.0	250	125 x 32

Load capacity shelf: 80 kg*
EasySTOP swivel castors and foot guards for your safety!



*Static distributed load; Total load of the transport device must not be exceeded!

ESD (electrostatic discharge)



Electrostatic charges and the resulting discharges still pose a major threat to sensitive goods in electronics. Moving over various ground materials can cause electrostatic charging of the user and the transport equipment. Delicate goods and electronic devices can be damaged by overvoltage or even completely destroyed. The **VARIOfit**® ESD transport devices therefore ensure that, due to their electrically conductive construction, the load surfaces of conductive decorative chipboard in light grey and the ESD powder coating in RAL 7024 graphite grey, especially those goods are protected from e.g. overvoltage damage according to EN 61340.



VARIOfit®

ESD (electrostatic discharge)

ESD trolleys (electrostatic discharge)



ESD material stands

Welded steel construction; Electrostatic discharge execution; Load surface with 22 mm high edge on one side or 18 mm high edge on all sides; Height adjustment range 500-755, 515-790, 695-1,065 or 750-1,000 mm in steps of 25 mm; Suitable for plastic crates 600 x 400 mm (W/D); Load surfaces fixed or one-sided tilts to 15° or 30°; Secure positioning by spring catch; Material stands powder-coated RAL 7024 graphite grey; Permanent surface protection; Impact- and scratch-resistant; Grey non-marking electrically conductive thermoplastic rubber tyres on plastic wheel rim with precision deepgroove ball bearings; Thread guard and foot guard; 4 swivel castors, 2 of them with brakes.

ESD Material stand

Article no.	Dimension			Loading surface		Weight	Load cap.	Wheel diam.
	W	D	H	w	d			
sw-405.040	610	410	770-1020	605	405	16.0	150	80 x 25

Swivel castors with wheel brakes!



Height adjustment in steps of 25 mm



ESD Material stand

Article no.	Dimension			Loading surface		Weight	Load cap.	Wheel diam.
	W	D	H	w	d			
sw-405.041	610	410	535-810	605	405	14.5	150	80 x 25

Swivel castors with wheel brakes!



Load surfaces tilted on one side



ESD Material stand, one-sided tiltable

Article no.	Dimension			Loading surface		Weight	Load cap.	Wheel diam.
	W	D	H	w	d			
sw-405.042	600	410	715-1085	510	410	15.0	150	80 x 25

Swivel castors with wheel brakes!



ESD Material stand, one-sided tiltable

Article no.	Dimension			Loading surface		Weight	Load cap.	Wheel diam.
	W	D	H	w	d			
sw-405.045	600	410	520-775	510	410	13.5	150	80 x 25

Swivel castors with wheel brakes!

ESD trolleys (electrostatic discharge)



ESD trolleys

Modular system; Electrostatic discharge execution; Base structure of innovative frame section; Load surfaces of electrically conductive faced chipboard light grey; Set in angle-steel frame, edge = 15 mm high; Load surfaces of ESD heavy-duty table trolley are flush with frame; Shelves of the ESD shelf trolleys are inserted in angle steel frame; Replaceable and removable as well as variable applicable; Trolleys powder-coated RAL 7024 graphite grey; Electrically conductive; Permanent surface protection; Impact- and scratch-resistant; Grey non-marking electrically conductive thermoplastic rubber tyres on plastic wheel rim with precision deepgroove ball bearings; Thread guard and foot guard; 2 **EasySTOP** swivel castors and 2 fixed castors.



ESD table trolley with 2 load surfaces

Article no.	Dimension			Loading surface		Weight	Load cap.	Wheel diam.
	W	mm D	H	w	d			
sw-500.557	975	525	1010	835	495	29,5	250	125 x 32
sw-600.557	1125	625	1010	985	595	35,0	250	125 x 32

Load capacity shelf: 80 kg*
EasySTOP swivel castors and foot guards for your safety!



ESD table trolley with 3 load surfaces

Article no.	Dimension			Loading surface		Weight	Load cap.	Wheel diam.
	W	mm D	H	w	d			
sw-500.657	975	525	1010	835	495	38,0	250	125 x 32
sw-600.657	1125	625	1010	985	595	46,0	250	125 x 32

Load capacity shelf: 80 kg*
EasySTOP swivel castors and foot guards for your safety!

ESD heavy-duty table trolley with 2 load surfaces

Article no.	Dimension			Loading surface		Weight	Load cap.	Wheel diam.
	W	mm D	H	w	d			
sw-500.562	1040	500	880	850	500	33,5	400	160 x 40
sw-600.562	1190	600	920	1000	600	41,0	500	200 x 40
sw-700.562	1190	700	920	1000	700	48,5	500	200 x 40
sw-800.562	1390	800	920	1200	800	54,5	500	200 x 40

Load capacity shelf: 200 kg*
EasySTOP swivel castors and foot guards for your safety!



ESD heavy-duty table trolley with 3 load surfaces

Article no.	Dimension			Loading surface		Weight	Load cap.	Wheel diam.
	W	mm D	H	w	d			
sw-500.662	1040	500	880	850	500	44,5	400	160 x 40
sw-600.662	1190	600	920	1000	600	53,5	500	200 x 40
sw-700.662	1190	700	920	1000	700	59,0	500	200 x 40
sw-800.662	1390	800	920	1200	800	70,0	500	200 x 40

Load capacity shelf: 200 kg*
EasySTOP swivel castors and foot guards for your safety!



*Static distributed load; Total load of the transport device must not be exceeded!



ESD shelf trolley, low

Article no.	Dimension			Loading surface		Weight	Load cap.	Wheel diam.
	W	D	H	w	d			
sw-500.257	910	500	990	850	500	41.5	250	160 x 40
sw-600.257	1060	600	990	1000	600	52.0	250	160 x 40
sw-700.257	1060	700	990	1000	700	56.5	250	160 x 40
sw-800.257	1260	800	990	1200	800	62.5	250	160 x 40

Load capacity shelf: 80 kg*
EasySTOP swivel castors and foot guards for your safety!



ESD shelf trolley, high

Article no.	Dimension			Loading surface		Weight	Load cap.	Wheel diam.
	W	D	H	w	d			
sw-500.258	910	500	1530	850	500	45.5	250	160 x 40
sw-600.258	1060	600	1530	1000	600	56.0	250	160 x 40
sw-700.258	1060	700	1530	1000	700	61.5	250	160 x 40
sw-800.258	1260	800	1530	1200	800	67.0	250	160 x 40

Load capacity shelf: 80 kg*
EasySTOP swivel castors and foot guards for your safety!



More products in ESD version available on request

ESD shelf trolley, high

Article no.	Dimension			Loading surface		Weight	Load cap.	Wheel diam.
	W	D	H	w	d			
sw-500.259	910	500	1530	850	500	54.0	250	160 x 40
sw-600.259	1060	600	1530	1000	600	72.5	250	160 x 40
sw-700.259	1060	700	1530	1000	700	81.0	250	160 x 40
sw-800.259	1260	800	1530	1200	800	107.0	250	160 x 40

Load capacity shelf: 80 kg*
EasySTOP swivel castors and foot guards for your safety!

Additional articles - Shelves for ESD shelf trolleys

Article no.	Dimension		for loading surface		Weight	Load cap.	
	W	D	w	d			
zsw-500.557	845	485	850	500	5.5	80	Additional shelf
zsw-600.557	995	585	1000	600	7.5	80	
zsw-700.557	995	685	1000	700	9.0	80	
zsw-800.557	1195	785	1200	800	12.5	80	



*Static distributed load; Total load of the transport device must not be exceeded!

ESD trolleys (electrostatic discharge)



ESD trolleys

Modular system; Electrostatic discharge execution; Base structure of ESD push bar trolleys with innovative frame section; Load surfaces of electrically conductive faced chipboard light grey; Base structure and shelves of ESD euro system dollies in angle-steel frame, edge = 10 mm high, or plates flush with frame; Transverse strut in push bar; Trolleys powder-coated RAL 7024 graphite grey; Electrically conductive; Permanent surface protection; Impact- and scratch-resistant; Grey non-marking electrically conductive thermoplastic rubber tyres on plastic wheel rim with precision deepgroove ball bearings; Thread guard and foot guard; 2 **EasySTOP** swivel castors and 2 fixed castors, or 4 swivel castors, 2 of them with **EasySTOP**, or 4 swivel castors and 2 of them with brakes.

ESD push bar trolley

Article no.	Dimension mm			Loading surface mm		Weight kg	Load cap. kg	Wheel diam. mm
	w	D	H	w	d			
sw-500.141	975	500	975	880	500	25.0	400	160 x 40
sw-600.141	1125	600	1015	1030	600	29.5	500	200 x 40
sw-700.141	1125	700	1015	1030	700	33.5	500	200 x 40
sw-800.141	1325	800	1015	1230	800	37.0	500	200 x 40

EasySTOP swivel castors and foot guards for your safety!

ESD euro system dolly with EasySTOP and 2 load surfaces (edge 10 mm)

Article no.	Dimension mm			Loading surface mm		Weight kg	Load cap. kg	Wheel diam. mm
	w	D	H	w	d			
sw-410.556	675	415	665	605	410	20.0	250	125 x 32

Load capacity shelf: 80 kg*
EasySTOP swivel castors and foot guards for your safety!

ESD euro system dolly with 2 load surfaces (edge 10 mm)

Article no.	Dimension mm			Loading surface mm		Weight kg	Load cap. kg	Wheel diam. mm
	w	D	H	w	d			
sw-410.516	675	415	635	605	410	19.0	250	125 x 32

Load capacity shelf: 80 kg*
Swivel castors with wheel brakes and foot guards for your safety!



ESD euro system dolly with EasySTOP and 2 load surfaces

Article no.	Dimension mm			Loading surface mm		Weight kg	Load cap. kg	Wheel diam. mm
	w	D	H	w	d			
sw-410.546	675	415	665	610	415	20.0	250	125 x 32

Load capacity shelf: 80 kg*
EasySTOP swivel castors and foot guards for your safety!

ESD euro system dolly with 2 load surfaces

Article no.	Dimension mm			Loading surface mm		Weight kg	Load cap. kg	Wheel diam. mm
	w	D	H	w	d			
sw-410.536	675	415	635	610	415	19.0	250	125 x 32

Load capacity shelf: 80 kg*
Swivel castors with wheel brakes and foot guards for your safety!

*Static distributed load; Total load of the transport device must not be exceeded!



ESD trolleys

Welded steel construction; Electrostatic discharge execution; Load surfaces of electrically conductive faced chipboard light grey; Plates flush with frame = 10 mm; ESD euro container trolleys: tilts to 17° or 32°; Clearance between cross tubes: 125 mm; Hole spacing for screwing shelves: 150 mm; ESD small order picking trolley: tilts to 15° or 30°; Trolleys powder-coated RAL 7024 graphite grey; Electrically conductive; Permanent surface protection; Impact- and scratch-resistant; Grey non-marking electrically conductive thermoplastic rubber tyres on plastic wheel rim with precision deepgroove ball bearings; Thread guard and foot guard; 4 swivel castors, 2 of them with brakes or 2 **EasySTOP** swivel castors and 2 fixed castors.

ESD euro container trolley with 5 ESD shelves

Article no.	Dimension			Loading surface		Weight	Load cap.	Wheel diam.
	w	D	H	w	d			
sw-610.315	1350	665	1700	1240	610	103.0	250	160 x 40

Load capacity shelf: 50 kg*
Swivel castors with wheel brakes and foot guards for your safety!



Shelves tilts to 15° or 30°

ESD small order picking trolley with 3 ESD sloping shelves

Article no.	Dimension			Loading surface		Weight	Load cap.	Wheel diam.
	w	D	H	w	d			
sw-400.844	815	455	1185	610	410	29.5	200	125 x 32

Load capacity shelf: 50 kg*
EasySTOP swivel castors and foot guards for your safety!



ESD push-handle dolly with 2 load surfaces

Article no.	Dimension			Loading surface		Weight	Load cap.	Wheel diam.
	w	D	H	w	d			
sw-450.832	940	455	910	610	455	17.0	200	125 x 32

Load capacity shelf: 100 kg*
EasySTOP swivel castors and foot guards for your safety!



*Static distributed load; Total load of the transport device must not be exceeded!

ESD trolleys (electrostatic discharge)

ESD table and workshop trolleys

Modular system; Electrostatic discharge execution; Base structure with innovative frame section; Load surfaces of electrically conductive faced chipboard light grey; Set in angle-steel frame, edge = 15 mm high; Either 2 lockable drawers, extractable until 70%; Inside dimensions of the drawers: 400 x 450 x 80 mm (W/D/H); Load capacity per drawer: 25 kg; Or 1 drawer cabinet with 4 drawers with sliding runners, lockable with a central cylinder lock; Load capacity per drawer: 25 kg; Execution with cupboard with 1 fixed and 2 variable cupboard shelves; Carrying capacity 30 kg per cupboard shelf; Trolleys, drawers and cupboard powder-coated RAL 7024 graphite grey; Electrically conductive; Permanent surface protection; Impact- and scratch-resistant; Grey non-marking electrically conductive thermoplastic rubber tyres on plastic wheel rim with precision deepgroove ball bearings; Thread guard and foot guard; 2 **EasySTOP** swivel castors and 2 fixed castors.



Suitable drawer divider set (zsw-600.604) on page 114

Inside dimension drawer: W=400 x D=450 x H=80 mm (2x)

ESD table trolley with 2 load surfaces and 2 drawers

Article no.	Dimension			Loading surface		Weight kg	Load cap. kg	Wheel diam. mm
	W	mm D	H	w	mm d			
sw-600.939	1175	625	850	985	590	46.0	250	125 x 32

Load capacity shelf: 80 kg*
EasySTOP swivel castors and foot guards for your safety!

Suitable drawer divider set (zsw-600.604) on page 114

Inside dimension drawer: W=400 x D=450 x H=80 mm (2x)



ESD table trolley with 2 load surfaces and 2 drawers

Article no.	Dimension			Loading surface		Weight kg	Load cap. kg	Wheel diam. mm
	W	mm D	H	w	mm d			
sw-600.959	1125	625	1010	985	590	46.0	250	125 x 32

Load capacity shelf: 80 kg*
EasySTOP swivel castors and foot guards for your safety!

*Static distributed load; Total load of the transport device must not be exceeded!





Inside dimensions cupboard:
W=470 x D=575 x H=575 mm (1x)

280 mm
280 mm

ESD workshop trolley with 3 load surfaces

Article no.	Dimension			Loading surface		Weight	Load cap.	Wheel diam.
	W	D	H	w	d			
sw-600.773	1125	625	1010	985	590	62.5	250	125 x 32

Load capacity shelf: 80 kg*
EasySTOP swivel castors and foot guards for your safety!

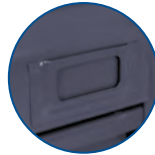

Label holder on the front of the drawer

Suitable drawer divider set (zsw-600.604) on page 114

Inside dimensions drawer:
B=390 x T=535 x H=95 mm (3x)
B=390 x T=535 x H=155 mm (1x)



280 mm
280 mm

ESD workshop trolley with 1 load surface

Article no.	Dimension			Loading surface		Weight	Load cap.	Wheel diam.
	W	D	H	w	d			
sw-600.775	1125	625	1010	985	590	80.5	250	125 x 32

Load capacity shelf: 80 kg*
EasySTOP swivel castors and foot guards for your safety!

ESD workshop trolley

Sheet steel construction; Electrostatic discharge execution; Working surface of 18 mm electrically conductive faced chipboard light grey; Cupboards with 1 fixed and 2 variable cupboard shelves; Carrying capacity 30 kg per cupboard shelf; Drawers with sliding runners; Central locking system with cylinder lock (simultaneous locking); Carrying capacity 25 kg per drawer; Trolley, drawers and cupboard powder-coated RAL 7024 graphite grey; Electrically conductive; Permanent surface protection; Impact- and scratch-resistant; Grey non-marking electrically conductive thermoplastic rubber tyres on plastic wheel rim with precision deepgroove ball bearings; Thread guard and foot guard; 2 **EasySTOP** swivel castors and 2 fixed castors.



Suitable drawer divider set (zsw-985.003) on page 116

Removable shelves for insertion at 30 mm intervals

Inside dimensions cupboard:
W=560 x D=515 x H=660 mm (1x)
Inside dimensions drawer:
W=290 x D=475 x H=95 mm (6x)

ESD workshop trolley with 6 drawers

Article no.	Dimension			Loading surface		Weight	Load cap.	Wheel diam.
	W	D	H	w	d			
sw-985.021	1110	600	960	1000	600	86.0	400	160 x 40

Load capacity shelf: 120 kg*
EasySTOP swivel castors and foot guards for your safety!

*Static distributed load; Total load of the transport device must not be exceeded!

ESD trolleys (electrostatic discharge)

ESD shelf trolleys fixed welded

Fixed welded angle-steel construction; Electrostatic discharge execution; With or without double wing door; Trolleys with double wing doors have espagnolette bolt lock with T-handle; Double wing door with cylinder lock, incl. 2 keys (different locking for order quantity >1); Push/pull bar and double wing door are flush with the frame when not in use; Push/pull bar with soft plastic grip cover black; End and side walls, roof and doors with mesh sides 50 x 50 mm; Load surface and shelves of electrically conductive faced chipboard light grey; Shelves inserted in angle steel frame; Shelf supports for variable insertion at 50 mm intervals; Trolleys powder-coated RAL 7024 graphite grey; Electrically conductive; Permanent surface protection; Impact- and scratch-resistant; Grey non-marking electrically conductive thermoplastic rubber tyres on plastic wheel rim with precision deepgroove ball bearings; Thread guard and foot guard; 2 **EasySTOP** swivel castors and 2 fixed castors.

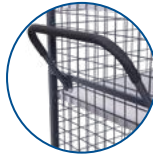

The push/pull bar rests on the cross tube when pushing. This ensures that pushing is safe and comfortable.

ESD shelf trolley fixed welded

Article no.	Dimension mm			Loading surface mm		Weight kg	Load cap. kg	Wheel diam. mm
	W	D	H	w	d			
sw-700.860	1115	730	1810	1045	685	103.5	500	200 x 40
sw-800.860	1315	830	1810	1245	785	120.5	500	200 x 40

Load capacity shelf: 80 kg*
EasySTOP swivel castors and foot guards for your safety!

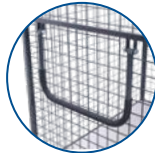

The push/pull bar is flush with the frame when not in use.



The double wing door opens 270° and is flush with the frame.

ESD shelf trolley fixed welded

Article no.	Dimension mm			Loading surface mm		Weight kg	Load cap. kg	Wheel diam. mm
	W	D	H	w	d			
sw-700.867	1115	730	1810	1045	685	117.5	500	200 x 40
sw-800.867	1315	830	1810	1245	785	140.0	500	200 x 40

Load capacity shelf: 80 kg*
EasySTOP swivel castors and foot guards for your safety!

Additional articles - ESD shelves of plywood for shelf trolleys

Article no.	Dimension mm		for loading surface mm		Weight kg	Load cap. kg	
	W	D	w	d			
zsw-700.421	1030	660	1045	685	11.0	120	Additional shelf
zsw-800.421	1230	760	1245	785	14.5	120	

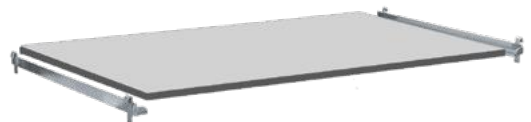

*Static distributed load; Total load of the transport device must not be exceeded!





ESD shelf trolleys fixed welded

Fixed welded angle-steel construction; Electrostatic discharge execution; With or without double wing door; Trolleys with double wing doors have espagnolette bolt lock with T-handle; Double wing door with cylinder lock, incl. 2 keys (different locking for order quantity >1); Push/pull bar and double wing door are flush with the frame when not in use; Push/pull bar with soft plastic grip cover black; End and side walls, roof and doors of galvanised steel sheet; Load surface and shelves of electrically conductive faced chipboard light grey; Shelves inserted in angle steel frame; Shelf supports for variable insertion at 100 mm intervals; Steel sheets powder-coated RAL 7024 graphite grey; Electrically conductive; Permanent surface protection; Impact- and scratch-resistant; Grey non-marking electrically conductive thermoplastic rubber tyres on plastic wheel rim with precision deepgroove ball bearings; Thread guard and foot guard; 2 **EasySTOP** swivel castors and 2 fixed castors.

The push/pull bar adjusts to the height of the person pulling when the trolley is being pulled.

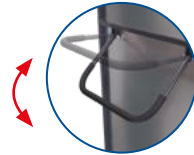

ESD shelf trolley fixed welded

Article no.	Dimension			Loading surface		Weight	Load cap.	Wheel diam.
	W	mm D	H	w	d			
sw-700.872	1115	730	1810	1045	685	123.0	500	200 x 40
sw-800.872	1315	830	1810	1245	785	153.0	500	200 x 40

Load capacity shelf: 80 kg*
EasySTOP swivel castors and foot guards for your safety!



ESD shelf trolley fixed welded

Article no.	Dimension			Loading surface		Weight	Load cap.	Wheel diam.
	W	mm D	H	w	d			
sw-700.868	1115	730	1810	1045	685	138.0	500	200 x 40
sw-800.868	1315	830	1810	1245	785	171.5	500	200 x 40

Load capacity shelf: 80 kg*
EasySTOP swivel castors and foot guards for your safety!



Additional articles - ESD shelves of plywood for shelf trolleys

Article no.	Dimension		for loading surface		Weight	Load cap.	
	W	mm D	w	d			
zsw-700.422	1000	660	1045	685	11.5	80	Additional shelf
zsw-800.422	1200	760	1245	785	16.0	80	

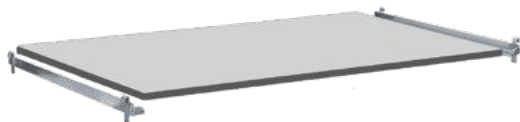

*Static distributed load; Total load of the transport device must not be exceeded!

Workshop trolleys



280 mm
280 mm

Workshop trolleys

Welded steel construction; Base structure with innovative frame section; Load surfaces of wood-based board, surface finish beech; Set in angle-steel frame, edge = 15 mm high; Cupboards with 1 fixed and 1 or 2 variable cupboard shelves; Carrying capacity 30 kg per cupboard shelf; Drawers with sliding runners; Cylinder lock (simultaneous locking); Carrying capacity 25 kg per drawer; Workshop trolley with double door and T-handle lock; Front powder-coated RAL 5010 gentian blue; Body powder-coated RAL 7035 light grey; Permanent surface protection; Impact- and scratch-resistant; Grey non-marking thermoplastic rubber tyres on plastic wheel rim with precision deepgroove ball bearings; Thread guard and foot guard; 2 **EasySTOP** swivel castors and 2 fixed castors.

Inside dimensions cupboard:
W=470 x D=575 x H=575 mm (1x)

Also available in ESD
design on page 107

Workshop trolley with 3 load surfaces

Article no.	Dimension			Loading surface		Weight kg	Load cap. kg	Wheel diam. mm
	w	D	H	w	d			
sw-600.603	1125	625	1010	985	590	62.5	250	125 x 32

Load capacity shelf: 80 kg*
EasySTOP swivel castors and foot guards for your safety!



Inside dimensions cupboard:
W=470 x D=575 x H=575 mm (1x)

Workshop trolley with 1 load surface

Article no.	Dimension			Loading surface		Weight kg	Load cap. kg	Wheel diam. mm
	w	D	H	w	d			
sw-600.604	1125	625	1010	985	590	76.0	250	125 x 32

Load capacity shelf: 80 kg*
EasySTOP swivel castors and foot guards for your safety!



Inside dimensions cupboard:
W=890 x D=575 x H=575 mm (1x)



Workshop trolley with 1 load surface

Article no.	Dimension			Loading surface		Weight kg	Load cap. kg	Wheel diam. mm
	w	D	H	w	d			
sw-600.640	1125	625	1010	985	590	67.5	250	125 x 32

Load capacity shelf: 80 kg*
EasySTOP swivel castors and foot guards for your safety!

*Static distributed load; Total load of the transport device must not be exceeded!



Suitable drawer divider set
(zsw-600.604) on page 114

Also available in ESD
design on page 107

Inside dimensions drawer:
B=390 x T=535 x H=95 mm (3x)
B=390 x T=535 x H=155 mm (1x)



Workshop trolley with 3 load surfaces

Article no.	Dimension			Loading surface		Weight	Load cap.	Wheel diam.
	W	D	H	w	d			
sw-600.605	1125	625	1010	985	590	80.5	250	125 x 32

Load capacity shelf: 80 kg*
EasySTOP swivel castors and foot guards for your safety!

Suitable drawer divider set
(zsw-600.604) on page 114

Inside dimensions cupboard:
W=470 x D=575 x H=575 mm (1x)
Inside dimensions drawer:
W=390 x D=535 x H=95 mm (3x)
W=390 x D=535 x H=155 mm (1x)



Workshop trolley with 1 load surface

Article no.	Dimension			Loading surface		Weight	Load cap.	Wheel diam.
	W	D	H	w	d			
sw-600.606	1125	625	1010	985	590	94.5	250	125 x 32

Load capacity shelf: 80 kg*
EasySTOP swivel castors and foot guards for your safety!



Suitable drawer divider set
(zsw-600.604) on page 114

Inside dimensions drawer:
B=390 x T=535 x H=95 mm (6x)
B=390 x T=535 x H=155 mm (2x)

Workshop trolley with 1 load surface

Article no.	Dimension			Loading surface		Weight	Load cap.	Wheel diam.
	W	D	H	w	d			
sw-600.608	1125	625	1010	985	590	112.0	250	125 x 32

Load capacity shelf: 80 kg*
EasySTOP swivel castors and foot guards for your safety!

*Static distributed load; Total load of the transport device must not be exceeded!

Workshop trolleys

Easy
STOPTUV
SUD

Workshop trolleys

Welded steel construction; Base structure with innovative frame section; Working surface of beech finish plywood; 80 mm high surround on three sides; Usable height: 875 mm; Set in angle-steel frame, edge = 15 mm high; Load surfaces of wood-based board, surface finish beech; Cupboards with 1 fixed and 2 variable cupboard shelves; Carrying capacity 30 kg per cupboard shelf; Drawers with sliding runners; Cylinder lock (simultaneous locking); Carrying capacity 25 kg per drawer; Front powder-coated RAL 5010 gentian blue; Body powder-coated RAL 7035 light grey; Permanent surface protection; Impact- and scratch-resistant; Grey non-marking thermoplastic rubber tyres on plastic wheel rim with precision deepgroove ball bearings; Thread guard and foot guard; 2 **EasySTOP** swivel castors and 2 fixed castors.

Inside dimensions cupboard:
W=470 x D=575 x H=575 mm (1x)

Workshop trolley with 3 load surfaces

Article no.	Dimension			Loading surface		Weight kg	Load cap. kg	Wheel diam. mm
	w	mm D	H	w	mm d			
sw-600.610	1220	640	955	1125	630	68.5	400	160 x 40

Load capacity shelf: 80 kg*
EasySTOP swivel castors and foot guards for your safety!



Inside dimensions cupboard:
W=470 x D=575 x H=575 mm (1x)
Inside dimensions drawer:
W=400 x D=450 x H=80 mm (1x)

Suitable drawer divider set
(zsw-600.604) on page 114

Workshop trolley with 2 load surfaces

Article no.	Dimension			Loading surface		Weight kg	Load cap. kg	Wheel diam. mm
	w	mm D	H	w	mm d			
sw-600.611	1220	640	955	1125	630	65.5	400	160 x 40

Load capacity shelf: 80 kg*
EasySTOP swivel castors and foot guards for your safety!

Suitable drawer divider set
(zsw-600.604) on page 114

Inside dimensions drawer:
B=390 x T=535 x H=95 mm (3x)
B=390 x T=535 x H=155 mm (1x)

Workshop trolley with 3 load surfaces

Article no.	Dimension			Loading surface		Weight kg	Load cap. kg	Wheel diam. mm
	w	mm D	H	w	mm d			
sw-600.612	1220	640	955	1125	630	86.0	400	160 x 40

Load capacity shelf: 80 kg*
EasySTOP swivel castors and foot guards for your safety!



Suitable drawer divider set
(zsw-600.604) on page 114

Inside dimensions cupboard:
W=470 x D=575 x H=575 mm (1x)
Inside dimensions drawer:
W=390 x D=535 x H=95 mm (3x)
W=390 x D=535 x H=155 mm (1x)

Workshop trolley with 1 load surface

Article no.	Dimension			Loading surface		Weight kg	Load cap. kg	Wheel diam. mm
	w	mm D	H	w	mm d			
sw-600.613	1220	640	955	1125	630	101.5	400	160 x 40

Load capacity shelf: 80 kg*
EasySTOP swivel castors and foot guards for your safety!



*Static distributed load; Total load of the transport device must not be exceeded!



Workshop trolleys

Welded steel construction; Base structure with innovative frame section; Load surfaces of wood-based board, surface finish beech; Plates flush with frame; Cupboards with 1 fixed and 2 variable cupboard shelves; Carrying capacity 30 kg per cupboard shelf; Drawers with sliding runners; Cylinder lock; Carrying capacity 25 kg per drawer; Front powder-coated RAL 5010 gentian blue; Body powder-coated RAL 7035 light grey; Permanent surface protection; Impact- and scratch-resistant; Grey non-marking thermoplastic rubber tyres on plastic wheel rim with precision deepgroove ball bearings; Thread guard and foot guard; 2 **EasySTOP** swivel castors and 2 fixed castors.

Suitable drawer divider set (zsw-600.604) on page 114

Inside dimensions drawer:
B=390 x T=535 x H=95 mm (3x)
B=390 x T=535 x H=155 mm (1x)

Workshop trolley with 2 load surfaces

Article no.	Dimension			Loading surface		Weight	Load cap.	Wheel diam.
	w	D	H	w	d			
sw-600.602	1190	600	930	1060	600	82.5	500	200 x 40

Load capacity shelf: 200 kg*
EasySTOP swivel castors and foot guards for your safety!

Inside dimensions cupboard:
W=470 x D=575 x H=575 mm (1x)

Workshop trolley with 2 load surfaces

Article no.	Dimension			Loading surface		Weight	Load cap.	Wheel diam.
	w	D	H	w	d			
sw-600.607	1190	600	930	1060	600	64.0	500	200 x 40

Load capacity shelf: 200 kg*
EasySTOP swivel castors and foot guards for your safety!



Heavy-duty workshop trolley

Welded steel construction; Base structure with innovative frame section; Load surfaces of waterproof bonded plywood, surface finish screen printed, anti slip; Cupboard with 1 fixed and 2 variable cupboard shelves; Carrying capacity 30 kg per cupboard shelf; Front powder-coated RAL 5010 gentian blue; Body powder-coated RAL 7035 light grey; Permanent surface protection; Impact- and scratch-resistant; Elastic solid-rubber tyres on cast aluminium wheel rim with precision deepgroove ball bearings with foot guard; 2 **EasySTOP** swivel castors and 2 fixed castors.

Inside dimensions cupboard:
sw-700.620: W=470 x D=675 x H=575 mm (1x)
sw-800.620: W=570 x D=775 x H=575 mm (1x)



Heavy-duty workshop trolley with 2 load surfaces

Article no.	Dimension			Loading surface		Weight	Load cap.	Wheel diam.
	w	D	H	w	d			
sw-700.620	1190	700	930	1060	700	81.0	1000	200 x 50
sw-800.620	1390	800	930	1260	800	96.5	1000	200 x 50

Load capacity shelf: 500 kg*
EasySTOP swivel castors and foot guards for your safety!

*Static distributed load; Total load of the transport device must not be exceeded!

Workshop trolleys



Workshop trolleys

Welded steel construction; Base structure with innovative frame section; Load surfaces of wood-based board, surface finish beech; Plates flush with frame; Cupboards with 1 fixed and 2 variable cupboard shelves; Carrying capacity 30 kg per cupboard shelf; Drawers with sliding runners; Cylinder lock (simultaneous locking); Carrying capacity 25 kg per drawer; Front powder-coated RAL 5010 gentian blue; Body powder-coated RAL 7035 light grey; Permanent surface protection; Impact- and scratch-resistant; Grey non-marking thermoplastic rubber tyres on plastic wheel rim with precision deepgroove ball bearings; Thread guard and foot guard; 2 **EasySTOP** swivel castors and 2 fixed castors.

Inside dimensions cupboard:
 W=470 x D=575 x H=575 mm (1x)
 Inside dimensions drawer:
 W=390 x D=535 x H=95 mm (3x)
 W=390 x D=535 x H=155 mm (1x)

Workshop trolley with 1 load surface

Article no.	Dimension mm			Loading surface mm		Weight kg	Load cap. kg	Wheel diam. mm
	W	D	H	w	d			
sw-600.698	1190	600	930	1060	600	103.5	500	200 x 40

Load capacity shelf: 200 kg*
 EasySTOP swivel castors and foot guards for your safety!



Inside dimensions drawer:
 B=390 x T=535 x H=95 mm (6x)
 B=390 x T=535 x H=155 mm (2x)

Workshop trolley with 1 load surface

Article no.	Dimension mm			Loading surface mm		Weight kg	Load cap. kg	Wheel diam. mm
	W	D	H	w	d			
sw-600.619	1190	600	930	1060	600	117.0	500	200 x 40

Load capacity shelf: 200 kg*
 EasySTOP swivel castors and foot guards for your safety!



Additional article - Drawer divider set

Article no.	Weight kg
zsw-600.604	1.0

Drawer divider set for products on page 28-29, 92, 93, 106, 111-113 and 117 (only sw-500.015)

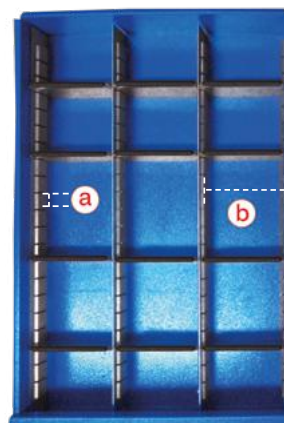

a) 25 mm b) 120 mm

*Static distributed load; Total load of the transport device must not be exceeded!





Additional article - Pegboard tool panel (for article on page 107, 112, 116, 117)

Article no.	Dimension		Weight kg	
	w	D		
zsw-100.500	995	450	7.0	for workshop trolleys with retaining edge
zsw-100.501	995	450	7.0	for workshop trolleys

**Additional article - Holder selection 28 parts
Article no. zsw-280.000**

6x	Tool holder with rising end
8x	Tool holder with vertical end
6x	Double tool holder
2x	Holder for pliers
1x	Machine holder
1x	Spanner holder
1x	Screwdriver holder
1x	Drill holder
2x	Saw holder

**Additional article - Holder selection 18 parts
Article no. zsw-180.000**

5x	Tool holder with rising end
2x	Tool holder with vertical end
3x	Double tool holder
3x	Tool clamp
2x	Holder for pliers
1x	Drill holder
1x	Spanner Holder
1x	Screwdriver holder

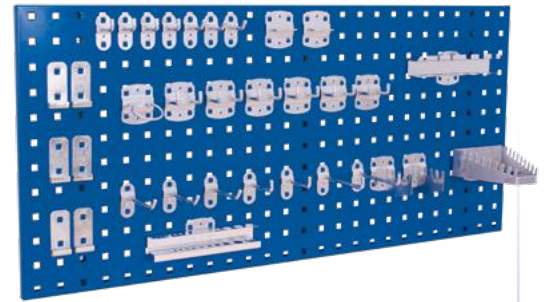

Additional article - Material crate

Article no.	Dimension			Weight kg	Colour
	w	D	H		
fk-105.000	105	85	45	0.1	green



Additional article - Material crate

Article no.	Dimension			Weight kg	Colour
	w	D	H		
fk-105.001	105	160	75	0.2	yellow



Additional article - Material crate

Article no.	Dimension			Weight kg	Colour
	w	D	H		
fk-140.000	140	230	130	0.3	red



Additional article - Material crate

Article no.	Dimension			Weight kg	Colour
	w	D	H		
fk-140.001	140	290	130	0.4	blue

Workshop trolleys

Workshop trolleys

Sheet steel construction; Working surface of beech finish plywood; With or without 80 mm high surround on three sides; Cupboards with 1 fixed and 2 variable cupboard shelves; Carrying capacity 30 kg per cupboard shelf; Drawers with sliding runners; Central locking system with cylinder lock (simultaneous locking); Carrying capacity 25 kg per drawer; Front and push bar powder-coated RAL 5010 gentian blue; Body powder-coated RAL 7035 light grey; Permanent surface protection; Impact- and scratch-resistant; Grey non-marking thermoplastic rubber tyres on plastic wheel rim with precision deepgroove ball bearings; Thread guard and foot guard; 2 **EasySTOP** swivel castors and 2 fixed castors.



Inside dimensions cupboard:
W=560 x D=515 x H=660 mm (1x)
Inside dimensions drawer:
W=290 x D=475 x H=95 mm (1x)
W=290 x D=475 x H=155 mm (2x)
W=290 x D=475 x H=130 mm (1x)

Workshop trolley with 4 drawers

Article no.	Dimension			Loading surface		Weight kg	Load cap. kg	Wheel diam. mm
	W	D	H	w	d			
sw-985.000	1110	600	960	1000	600	83.5	400	160 x 40

Load capacity shelf: 120 kg*
EasySTOP swivel castors and foot guards for your safety!

Also available in ESD
design on page 107

Removable shelves for
insertion at 30 mm intervals

Inside dimensions cupboard:
W=560 x D=515 x H=660 mm (1x)
Inside dimensions drawer:
W=290 x D=475 x H=95 mm (6x)



Workshop trolley with 6 drawers

Article no.	Dimension			Loading surface		Weight kg	Load cap. kg	Wheel diam. mm
	W	D	H	w	d			
sw-985.001	1110	600	960	1000	600	86.0	400	160 x 40

Load capacity shelf: 120 kg*
EasySTOP swivel castors and foot guards for your safety!

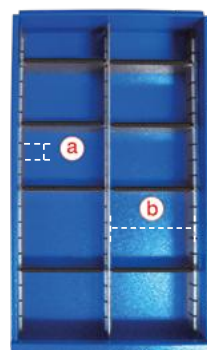

a) 25 mm b) 135 mm

Additional article - Drawer divider set

Article no.		Weight kg
zsw-985.003	Drawer divider set for products on pages 107, 116-117 (except sw-500.015)	1.0

*Static distributed load; Total load of the transport device must not be exceeded!





Label holder on the front of the drawer



Inside dimensions cupboard:
W=560 x D=515 x H=660 mm (1x)
Inside dimensions drawer:
W=290 x D=475 x H=95 mm (1x)
W=290 x D=475 x H=155 mm (2x)
W=290 x D=475 x H=130 mm (1x)



Workshop trolley with 4 drawers and edge

Article no.	Dimension			Loading surface		Weight	Load cap.	Wheel diam.
	W	D	H	w	d			
sw-985.002	1125	610	1040	1000	600	85.0	400	160 x 40

Load capacity shelf: 120 kg*
EasySTOP swivel castors and foot guards for your safety!

Inside dimensions cupboard:
W=560 x D=515 x H=660 mm (1x)
Inside dimensions drawer:
W=290 x D=475 x H=95 mm (6x)



Workshop trolley with 6 drawers and edge

Article no.	Dimension			Loading surface		Weight	Load cap.	Wheel diam.
	W	D	H	w	d			
sw-985.003	1125	610	1040	1000	600	87.5	400	160 x 40

Load capacity shelf: 120 kg*
EasySTOP swivel castors and foot guards for your safety!



Inside dimensions cupboard:
W=470 x D=575 x H=575 mm (1x)

Cabinet with hinged door and 1 load surface

Article no.	Dimension			Loading surface		Weight	Load cap.	Wheel diam.
	W	D	H	w	d			
sw-500.014	575	660	905	550	650	39.0	150	125 x 32

Load capacity shelf: 120 kg*
EasySTOP swivel castors and foot guards for your safety!



Inside dimensions drawer:
B=390 x T=535 x H=95 mm (3x)
B=390 x T=535 x H=155 mm (1x)

Suitable drawer divider set
(zsw-600.604) on page 114

Cabinet with 4 drawers and 1 load surface

Article no.	Dimension			Loading surface		Weight	Load cap.	Wheel diam.
	W	D	H	w	d			
sw-500.015	575	660	905	550	650	54.0	150	125 x 32

Load capacity shelf: 120 kg*
EasySTOP swivel castors and foot guards for your safety!

*Static distributed load; Total load of the transport device must not be exceeded!

Shelf trolleys, low



Shelf trolleys, low

Modular system; Base structure with innovative frame section; Load surface, shelves and trays of wood-based board, surface finish beech; Shelves and trays replaceable and variable removable; Tray height 45 mm inside and 60 mm outside; Trolleys powder-coated RAL 5010 gentian blue; Permanent surface protection; Impact- and scratch-resistant; Grey non-marking thermoplastic rubber tyres on plastic wheel rim with precision deepgroove ball bearings; Thread guard and foot guard; 2 **EasySTOP** swivel castors and 2 fixed castors.

Shelf trolley, low

Article no.	Dimension			Loading surface		Weight kg	Load cap. kg	Wheel diam. mm
	W	mm D	H	w	mm d			
sw-500.205	910	500	990	850	500	31.5	250	160 x 40
sw-600.205	1060	600	990	1000	600	43.0	250	160 x 40
sw-700.239	1060	700	990	1000	700	48.0	250	160 x 40
sw-800.239	1260	800	990	1200	800	52.5	250	160 x 40

Load capacity shelf: 80 kg*
EasySTOP swivel castors and foot guards for your safety!



Shelf trolley, low

Article no.	Dimension			Loading surface		Weight kg	Load cap. kg	Wheel diam. mm
	W	mm D	H	w	mm (Tray) d			
sw-500.207	910	500	990	815	455	34.0	250	160 x 40
sw-600.207	1060	600	990	965	555	43.0	250	160 x 40
sw-700.242	1060	700	990	965	655	51.0	250	160 x 40
sw-800.242	1260	800	990	1165	755	63.5	250	160 x 40

Load capacity shelf: 80 kg*
EasySTOP swivel castors and foot guards for your safety!

Shelf trolley, low

Article no.	Dimension			Loading surface		Weight kg	Load cap. kg	Wheel diam. mm
	W	mm D	H	mm (Tray) w	d			
sw-500.208	910	500	990	815	455	35.0	250	160 x 40
sw-600.208	1060	600	990	965	555	43.5	250	160 x 40
sw-700.243	1060	700	990	965	655	52.5	250	160 x 40
sw-800.243	1260	800	990	1165	755	64.5	250	160 x 40

Load capacity shelf: 80 kg*
EasySTOP swivel castors and foot guards for your safety!



Additional articles - Shelves for shelf trolleys

Article no.	Dimension		for loading surface		Weight kg	Load cap. kg	
	mm	mm	mm	mm			
zsw-500.205	845	485	850	500	6.5	80	Additional shelf
zsw-600.210	995	585	1000	600	8.0	80	
zsw-700.210	995	685	1000	700	10.5	80	
zsw-800.210	1195	785	1200	800	14.0	80	



*Static distributed load; Total load of the transport device must not be exceeded!



Also available in ESD design on page 103



Shelf trolley, low

Article no.	Dimension			Loading surface		Weight	Load cap.	Wheel diam.
	W	mm D	H	w	mm d			
sw-500.206	910	500	990	850	500	37.0	250	160 x 40
sw-600.206	1060	600	990	1000	600	46.0	250	160 x 40
sw-700.240	1060	700	990	1000	700	54.5	250	160 x 40
sw-800.240	1260	800	990	1200	800	67.0	250	160 x 40

Load capacity shelf: 80 kg*
EasySTOP swivel castors and foot guards for your safety!



Shelf trolley, low

Article no.	Dimension			Loading surface		Weight	Load cap.	Wheel diam.
	W	mm D	H	mm (Tray) w	mm (Tray) d			
sw-500.210	910	500	990	815	455	38.0	250	160 x 40
sw-600.210	1060	600	990	965	555	47.0	250	160 x 40
sw-700.241	1060	700	990	965	655	55.5	250	160 x 40
sw-800.241	1260	800	990	1165	755	68.5	250	160 x 40

Load capacity shelf: 80 kg*
EasySTOP swivel castors and foot guards for your safety!



Shelf trolley, low

Article no.	Dimension			Loading surface		Weight	Load cap.	Wheel diam.
	W	mm D	H	mm (Tray) w	mm (Tray) d			
sw-500.209	910	500	990	815	455	45.0	250	160 x 40
sw-600.209	1060	600	990	965	555	51.5	250	160 x 40
sw-700.244	1060	700	990	965	655	60.0	250	160 x 40
sw-800.244	1260	800	990	1165	755	69.5	250	160 x 40

Load capacity shelf: 80 kg*
EasySTOP swivel castors and foot guards for your safety!



Additional article - Trays for shelf trolleys

Article no.	Dimension			for loading surface		Weight	Load cap.	
	W	mm D	H	w	mm d			
zsw-500.209	815	455	45	850	500	6.5	80	Additional tray
zsw-600.209	965	555	45	1000	600	9.0	80	
zsw-700.209	965	655	45	1000	700	10.5	80	
zsw-800.209	1165	755	45	1200	800	15.0	80	

*Static distributed load; Total load of the transport device must not be exceeded!



Shelf trolleys, high



Shelf trolleys, high

Modular system; Base structure with innovative frame section; Load surface, shelves and trays of wood-based board, surface finish beech; Shelves and trays replaceable and variable removable; Shelf trolley high with dead man's brake with tubular push bar with dead man's control and additional handle beneath the push bar; Tray height 45 mm inside and 60 mm outside; Trolleys powder-coated RAL 5010 gentian blue; Permanent surface protection; Impact- and scratch-resistant; Grey non-marking thermoplastic rubber tyres on plastic wheel rim with precision deepgroove ball bearings; Thread guard and foot guard; 2 **EasySTOP** swivel castors and 2 fixed castors, or 2 swivel castors with dead man's brake and 2 fixed castors.

Also available in ESD design on page 103

Shelf trolley, high

Article no.	Dimension			Loading surface		Weight kg	Load cap. kg	Wheel diam. mm
	W	mm D	H	w	d			
sw-500.211	910	500	1530	850	500	42.0	250	160 x 40
sw-600.211	1060	600	1530	1000	600	51.0	250	160 x 40
sw-700.245	1060	700	1530	1000	700	60.0	250	160 x 40
sw-800.245	1260	800	1530	1200	800	73.0	250	160 x 40

Load capacity shelf: 80 kg*
EasySTOP swivel castors and foot guards for your safety!

Dead man's brake



Shelf trolley, high with dead man's brake

Article no.	Dimension			Loading surface		Weight kg	Load cap. kg	Wheel diam. mm
	W	mm D	H	w	d			
sw-600.265	1220	610	1530	1000	600	56.5	250	160 x 40

Load capacity shelf: 80 kg*
Swivel castors with dead man's brake and foot guards for your safety!

Also available in ESD design on page 103

Shelf trolley, high

Article no.	Dimension			Loading surface		Weight kg	Load cap. kg	Wheel diam. mm
	W	mm D	H	w	d			
sw-500.212	910	500	1530	850	500	54.0	250	160 x 40
sw-600.212	1060	600	1530	1000	600	68.5	250	160 x 40
sw-700.246	1060	700	1530	1000	700	80.5	250	160 x 40
sw-800.246	1260	800	1530	1200	800	101.5	250	160 x 40

Load capacity shelf: 80 kg*
EasySTOP swivel castors and foot guards for your safety!



*Static distributed load; Total load of the transport device must not be exceeded!



Shelf trolley, high

Article no.	Dimension mm			Loading surface mm (Tray)		Weight kg	Load cap. kg	Wheel diam. mm
	w	D	H	w	d			
sw-500.213	910	500	1530	815	455	45.0	250	160 x 40
sw-600.213	1060	600	1530	965	555	56.0	250	160 x 40
sw-700.247	1060	700	1530	965	655	65.5	250	160 x 40
sw-800.247	1260	800	1530	1165	755	80.0	250	160 x 40

Load capacity shelf: 80 kg*
EasySTOP swivel castors and foot guards for your safety!



Shelf trolley, high

Article no.	Dimension mm			Loading surface mm (Tray)		Weight kg	Load cap. kg	Wheel diam. mm
	w	D	H	w	d			
sw-500.214	910	500	1530	815	455	60.0	250	160 x 40
sw-600.214	1060	600	1530	965	555	72.5	250	160 x 40
sw-700.248	1060	700	1530	965	655	85.5	250	160 x 40
sw-800.248	1260	800	1530	1165	755	105.0	250	160 x 40

Load capacity shelf: 80 kg*
EasySTOP swivel castors and foot guards for your safety!



Additional article - Trays for shelf trolleys

Article no.	Dimension mm			for loading surface mm		Weight kg	Load cap. kg
	w	D	H	w	d		
zsw-500.209	815	455	45	850	500	6.5	80
zsw-600.209	965	555	45	1000	600	9.0	80
zsw-700.209	965	655	45	1000	700	10.5	80
zsw-800.209	1165	755	45	1200	800	15.0	80

Additional tray



Additional articles - Shelves for shelf trolleys

Article no.	Dimension mm		for loading surface mm		Weight kg	Load cap. kg
	w	D	w	d		
zsw-500.205	845	485	850	500	6.5	80
zsw-600.210	995	585	1000	600	8.0	80
zsw-700.210	995	685	1000	700	10.5	80
zsw-800.210	1195	785	1200	800	14.0	80

Additional shelf



*Static distributed load; Total load of the transport device must not be exceeded!



Customizing



Standard



Customizing



Standard



Customizing



VARIOfit[®]

Customizing comparison

Shelf trolleys with folding shelves



Shelf trolleys with folding shelves

Welded steel construction; Base structure with innovative frame section; Fixed welded tubular push bar; Load surface and shelves of wood-based board, surface finish beech; Folding shelves; End and side walls open or with mesh size 100 x 200 mm; Trolleys powder-coated RAL 5010 gentian blue; Permanent surface protection; Impact- and scratch-resistant; Grey non-marking thermoplastic rubber tyres on plastic wheel rim with precision deepgroove ball bearings; Thread guard and foot guard; 2 **EasySTOP** swivel castors and 2 fixed castors.



Shelf trolley, high with folding shelves

Article no.	Dimension			Loading surface		Weight	Load cap.	Wheel diam.
	W	D	H	w	d			
sw-700.250	1200	700	1890	975	700	73.0	500	200 x 40
sw-800.250	1400	800	1890	1175	800	84.5	500	200 x 40

Load capacity shelf: 50 kg*
EasySTOP swivel castors and foot guards for your safety!

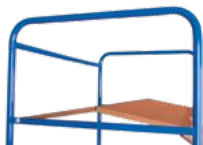

380 mm
380 mm
375 mm



Shelf trolley, high with folding shelves

Article no.	Dimension			Loading surface		Weight	Load cap.	Wheel diam.
	W	D	H	w	d			
sw-700.238	1200	700	1890	975	700	67.5	500	200 x 40
sw-800.238	1400	800	1890	1175	800	80.0	500	200 x 40

Load capacity shelf: 50 kg*
EasySTOP swivel castors and foot guards for your safety!

*Static distributed load; Total load of the transport device must not be exceeded!

Parcel trolleys



Parcel trolleys

Modular system; Base structure with innovative frame section; Screwed tubular push bar; 2 screwed connecting tubes; Load surface of wood-based board, surface finish beech; Optional removable shelves for insertion at 120 mm intervals; Mesh sides and ends, mesh size 120 x 120 mm; Side walls replaceable and variable removable; Trolleys powder-coated RAL 5010 gentian blue; Permanent surface protection; Impact- and scratch-resistant; Grey non-marking thermoplastic rubber tyres on plastic wheel rim with precision deepgroove ball bearings; Thread guard and foot guard; 2 **EasySTOP** swivel castors and 2 fixed castors.



Three-sided parcel trolley, high

Article no.	Dimension			Loading surface		Weight kg	Load cap. kg	Wheel diam. mm
	W	mm D	H	w mm	d			
sw-500.306	1040	525	1780	850	500	43.0	400	160 x 40
sw-600.306	1190	625	1820	1000	600	52.0	500	200 x 40
sw-700.306	1190	725	1820	1000	700	60.5	500	200 x 40
sw-800.306	1390	825	1820	1200	800	68.5	500	200 x 40

EasySTOP swivel castors and foot guards for your safety!



Four-sided parcel trolley, high

Article no.	Dimension			Loading surface		Weight kg	Load cap. kg	Wheel diam. mm
	W	mm D	H	w mm	d			
sw-500.405	1040	540	1780	850	500	49.0	400	160 x 40
sw-600.405	1190	640	1820	1000	600	57.5	500	200 x 40
sw-700.403	1190	740	1820	1000	700	68.0	500	200 x 40
sw-800.403	1390	840	1820	1200	800	76.0	500	200 x 40

EasySTOP swivel castors and foot guards for your safety!

Three-sided parcel trolley, low

Article no.	Dimension			Loading surface		Weight kg	Load cap. kg	Wheel diam. mm
	W	mm D	H	w mm	d			
sw-500.313	1040	525	1180	850	500	35.0	400	160 x 40
sw-600.313	1190	625	1220	1000	600	43.0	500	200 x 40
sw-700.313	1190	725	1220	1000	700	50.5	500	200 x 40
sw-800.313	1390	825	1220	1200	800	57.5	500	200 x 40

EasySTOP swivel castors and foot guards for your safety!



Four-sided parcel trolley, low

Article no.	Dimension			Loading surface		Weight kg	Load cap. kg	Wheel diam. mm
	W	mm D	H	w mm	d			
sw-500.420	1040	540	1180	850	500	40.0	400	160 x 40
sw-600.420	1190	640	1220	1000	600	47.0	500	200 x 40
sw-700.220	1190	740	1220	1000	700	54.5	500	200 x 40
sw-800.220	1390	840	1220	1200	800	61.5	500	200 x 40

EasySTOP swivel castors and foot guards for your safety!



Shelf trolleys

Shelf trolleys

Modular system; Base structure with innovative frame section; Screwed tubular push bar; 2 screwed connecting tubes; Load surface and shelves of wood-based board, surface finish beech; Optional removable shelves for insertion at 120 mm; Mesh sides and ends, mesh size 120 x 120 mm; Side walls replaceable and variable removable; Trolleys powder-coated RAL 5010 gentian blue; Permanent surface protection; Impact- and scratch-resistant; Grey non-marking thermoplastic rubber tyres on plastic wheel rim with precision deepgroove ball bearings; Thread guard and foot guard; 2 **EasySTOP** swivel castors and 2 fixed castors.

Shelf trolley, low

Article no.	Dimension			Loading surface		Weight	Load cap.	Wheel diam.
	W	D	H	w	d			
sw-500.235	1035	520	1180	850	500	55.5	400	160 x 40
sw-600.235	1185	620	1220	1000	600	63.0	500	200 x 40
sw-700.215	1185	720	1220	1000	700	67.5	500	200 x 40
sw-800.215	1385	820	1220	1200	800	79.0	500	200 x 40

Load capacity shelf: 80 kg*
EasySTOP swivel castors and foot guards for your safety!



Shelf trolley, low

Article no.	Dimension			Loading surface		Weight	Load cap.	Wheel diam.
	W	D	H	w	d			
sw-500.307	1040	525	1180	850	500	59.0	400	160 x 40
sw-600.307	1190	625	1220	1000	600	66.5	500	200 x 40
sw-700.303	1190	725	1220	1000	700	70.5	500	200 x 40
sw-800.303	1390	825	1220	1200	800	85.0	500	200 x 40

Load capacity shelf: 80 kg*
EasySTOP swivel castors and foot guards for your safety!



Shelf trolley, low

Article no.	Dimension			Loading surface		Weight	Load cap.	Wheel diam.
	W	D	H	w	d			
sw-500.460	1040	540	1180	850	500	61.5	400	160 x 40
sw-600.460	1190	640	1220	1000	600	73.0	500	200 x 40
sw-700.460	1190	740	1220	1000	700	76.5	500	200 x 40
sw-800.460	1390	840	1220	1200	800	92.0	500	200 x 40

Load capacity shelf: 80 kg*
EasySTOP swivel castors and foot guards for your safety!

Additional articles - Shelves for parcel/shelf trolleys

Article no.	Dimension		for loading surface		Weight	Load cap.	
	W	D	w	d			
zsw-500.218	835	470	850	500	8.0	80	
zsw-600.218	985	570	1000	600	10.0	80	Additional shelf incl. angle support
zsw-700.218	985	670	1000	700	12.0	80	
zsw-800.218	1185	770	1200	800	16.0	80	

Additional articles - Side walls for parcel/shelf trolleys, low

Article no.	Dimension		for loading surface		Weight	
	W	H	w	d		
gsw-500.303	925	925	850	500	5.5	Additional side wall low
gsw-700.303.2	1075	925	1000	600	6.0	
gsw-700.303.2	1075	925	1000	700	6.0	
gsw-800.303.2	1275	925	1200	800	8.0	

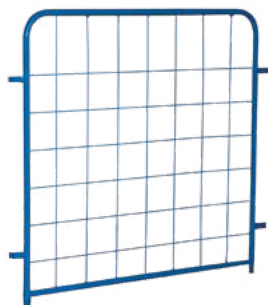

Shelf trolleys



Shelf trolley, high

Article no.	Dimension			Loading surface		Weight	Load cap.	Wheel diam.
	mm	mm	mm	mm	mm			
	W	D	H	w	d	kg	kg	mm
sw-500.236	1035	520	1780	850	500	64.0	400	160 x 40
sw-600.236	1185	620	1820	1000	600	81.0	500	200 x 40
sw-700.216	1185	720	1820	1000	700	84.0	500	200 x 40
sw-800.216	1385	820	1820	1200	800	102.5	500	200 x 40

Load capacity shelf: 80 kg*
EasySTOP swivel castors and foot guards for your safety!



Shelf trolley with dead man's brake

Welded steel construction; Base structure with innovative frame section; Tubular push bar with dead man's control; Additional handle beneath the push bar; Load surface and shelves of wood-based board, surface finish beech; Optional removable shelves for insertion at 120 mm; Mesh ends, mesh size 120 x 120 mm; Trolley powder-coated RAL 5010 gentian blue; Permanent surface protection; Impact- and scratch-resistant; Grey non-marking thermoplastic rubber tyres on plastic wheel rim with precision deepgroove ball bearings; Thread guard and foot guard; 2 swivel castors with dead man's brake and 2 fixed castors.



Shelf trolley, high with dead man's brake

Article no.	Dimension			Loading surface		Weight	Load cap.	Wheel diam.
	mm	mm	mm	mm	mm			
	W	D	H	w	d	kg	kg	mm
sw-700.280	1195	715	1825	1000	700	83.0	500	200 x 40

Load capacity shelf: 80 kg*
Swivel castors with dead man's brake and foot guards for your safety!



Shelf trolley, high

Article no.	Dimension			Loading surface		Weight	Load cap.	Wheel diam.
	mm	mm	mm	mm	mm			
	W	D	H	w	d	kg	kg	mm
sw-500.237	1035	520	1780	850	500	70.0	400	160 x 40
sw-600.237	1185	620	1820	1000	600	87.5	500	200 x 40
sw-700.217	1185	720	1820	1000	700	95.5	500	200 x 40
sw-800.217	1385	820	1820	1200	800	116.0	500	200 x 40

Load capacity shelf: 80 kg*
EasySTOP swivel castors and foot guards for your safety!

Additional articles - Side walls for parcel/shelf trolleys, high

Article no.	Dimension		for loading surface		Weight
	mm	mm	mm	mm	
	W	H	w	d	kg
gsw-500.304	925	1525	850	500	8.0
gsw-700.304.2	1075	1525	1000	600	9.0
gsw-700.304.2	1075	1525	1000	700	9.0
gsw-800.304.2	1275	1525	1200	800	10.5

Additional side wall high

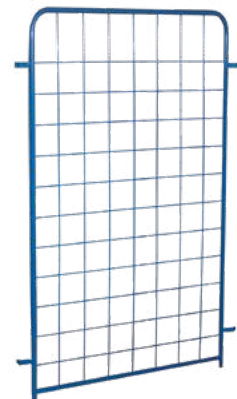

*Static distributed load; Total load of the transport device must not be exceeded!



Shelf trolleys

Modular system; Base structure with innovative frame section; Screwed tubular push bar; 2 screwed connecting tubes; Load surface and shelves of wood-based board, surface finish beech; Optional removable shelves for insertion at 120 mm; Mesh sides and ends, mesh size 120 x 120 mm; Side walls replaceable and variable removable; Trolleys powder-coated RAL 5010 gentian blue; Permanent surface protection; Impact- and scratch-resistant; Grey non-marking thermoplastic rubber tyres on plastic wheel rim with precision deepgroove ball bearings; Thread guard and foot guard; 2 **EasySTOP** swivel castors and 2 fixed castors.

Shelf trolley, high

Article no.	Dimension			Loading surface		Weight kg	Load cap. kg	Wheel diam. mm
	W	mm D	H	w mm	d			
sw-500.304	1040	525	1780	850	500	73.5	400	160 x 40
sw-600.304	1190	625	1820	1000	600	86.5	500	200 x 40
sw-700.304	1190	725	1820	1000	700	91.0	500	200 x 40
sw-800.304	1390	825	1820	1200	800	103.0	500	200 x 40

Load capacity shelf: 80 kg*
EasySTOP swivel castors and foot guards for your safety!

Shelf trolley, high

Article no.	Dimension			Loading surface		Weight kg	Load cap. kg	Wheel diam. mm
	W	mm D	H	w mm	d			
sw-500.311	1040	540	1780	850	500	83.5	400	160 x 40
sw-600.311	1190	640	1820	1000	600	96.5	500	200 x 40
sw-700.311	1190	740	1820	1000	700	101.0	500	200 x 40
sw-800.311	1390	840	1820	1200	800	113.0	500	200 x 40

Load capacity shelf: 80 kg*
EasySTOP swivel castors and foot guards for your safety!



Shelf trolley, high

Article no.	Dimension			Loading surface		Weight kg	Load cap. kg	Wheel diam. mm
	W	mm D	H	w mm	d			
sw-500.305	1040	525	1780	850	500	78.5	400	160 x 40
sw-600.305	1190	625	1820	1000	600	91.5	500	200 x 40
sw-700.305	1190	725	1820	1000	700	96.0	500	200 x 40
sw-800.305	1390	825	1820	1200	800	108.0	500	200 x 40

Load capacity shelf: 80 kg*
EasySTOP swivel castors and foot guards for your safety!

Additional articles - Side wall with folding top half for parcel/shelf trolleys, high

Article no.	Dimension		for loading surface		Weight kg	Additional side wall with folding top half
	W	H	w mm	d		
gsw-500.305	945	1525	850	500	9.0	
gsw-600.305	1095	1525	1000	600	10.5	
gsw-700.305	1095	1525	1000	700	12.0	
gsw-800.305	1295	1525	1200	800	15.0	



*Static distributed load; Total load of the transport device must not be exceeded!

Shelf trolleys fixed welded

Shelf trolleys fixed welded

Fixed welded angle-steel construction; With or without double wing door; Trolleys with double wing doors have espagnolette bolt lock with T-handle or lever; Double wing door with cylinder lock, incl. 2 keys (different locking); Push/pull bar and double wing door are flush with the frame when not in use; Push/pull bar with soft plastic grip cover black; End and side walls, roof and doors with mesh sides 50 x 50 mm; Load surface and shelves of wood-based board, surface finish beech; Shelf supports for variable insertion at 50 mm intervals; Trolleys powder-coated RAL 5010 gentian blue; Permanent surface protection; Impact- and scratch-resistant; Grey non-marking thermoplastic rubber tyres on plastic wheel rim with precision deepgroove ball bearings; Thread guard and foot guard; 2 **EasySTOP** swivel castors and 2 fixed castors.

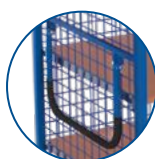

The push/pull bar is flush with the frame when not in use.

Also available in ESD design on page 108

Shelf trolley fixed welded

Article no.	Dimension			Loading surface		Weight kg	Load cap. kg	Wheel diam. mm
	W	mm D	H	w	mm d			
sw-700.410	1115	730	1810	1045	685	103.5	500	200 x 40
sw-800.410	1315	830	1810	1245	785	120.5	500	200 x 40

Load capacity shelf: 80 kg*

EasySTOP swivel castors and foot guards for your safety!

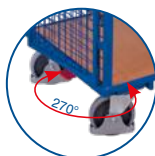

The double wing door opens 270° and is flush with the frame.

Shelf trolley fixed welded

Article no.	Dimension			Loading surface		Weight kg	Load cap. kg	Wheel diam. mm
	W	mm D	H	w	mm d			
sw-700.440	1115	810	1810	1045	685	77.0	500	200 x 40
sw-800.440	1315	910	1810	1245	785	89.5	500	200 x 40

EasySTOP swivel castors and foot guards for your safety!

*Static distributed load; Total load of the transport device must not be exceeded!

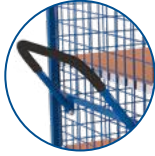

The push/pull bar rests on the cross tube when pushing. This ensures that pushing is safe and comfortable.



Shelf trolley fixed welded

Article no.	Dimension			Loading surface		Weight	Load cap.	Wheel diam.
	W	D	H	w	d			
sw-700.411	1115	810	1810	1045	685	117.5	500	200 x 40
sw-800.411	1315	910	1810	1245	785	140.0	500	200 x 40

Load capacity shelf: 80 kg*
EasySTOP swivel castors and foot guards for your safety!

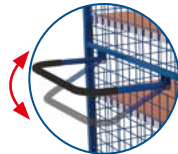

The push/pull bar adjusts to the height of the person pulling when the trolley is being pulled.



Also available in ESD design on page 108

Shelf trolley fixed welded

Article no.	Dimension			Loading surface		Weight	Load cap.	Wheel diam.
	W	D	H	w	d			
sw-700.987	1115	730	1810	1045	685	117.5	500	200 x 40
sw-800.987	1315	830	1810	1245	785	140.0	500	200 x 40

Load capacity shelf: 80 kg*
EasySTOP swivel castors and foot guards for your safety!

Additional articles - Shelves of wood-based board for shelf trolleys

Article no.	Dimension		for loading surface		Weight	Load cap.	
	W	D	w	d			
zsw-700.411	1030	660	1045	685	11.5	80	Additional shelf
zsw-800.411	1230	760	1245	785	16.0	80	



Additional articles - Shelves of plywood for shelf trolleys

Article no.	Dimension		for loading surface		Weight	Load cap.	
	W	D	w	d			
zsw-700.412	1030	660	1045	685	11.0	120	Additional shelf
zsw-800.412	1230	760	1245	785	14.5	120	



Additional articles - Shelves of waterproof bonded plywood, surface finish screen printed for shelf trolleys

Article no.	Dimension		for loading surface		Weight	Load cap.	
	W	D	w	d			
zsw-700.416	1030	660	1045	685	11.5	120	Additional shelf
zsw-800.416	1230	760	1245	785	15.5	120	



*Static distributed load; Total load of the transport device must not be exceeded!

Shelf trolleys fixed welded



Shelf trolleys fixed welded

Fixed welded angle-steel construction; With or without double wing door; Trolleys with double wing doors have espagnolette bolt lock with T-handle or lever; Double wing door with cylinder lock, incl. 2 keys (different locking); Push/pull bar and double wing door are flush with the frame when not in use; Push/pull bar with soft plastic grip cover black; End and side walls, roof and doors of galvanised steel sheet; Load surface and shelves of wood-based board, surface finish beech; Shelf supports for variable insertion at 100 mm intervals; Steel sheets powder-coated RAL 5010 gentian blue; Permanent surface protection; Impact- and scratch-resistant; Grey non-marking thermoplastic rubber tyres on plastic wheel rim with precision deepgroove ball bearings; Thread guard and foot guard; 2 **EasySTOP** swivel castors and 2 fixed castors.



Roller shutter door on request

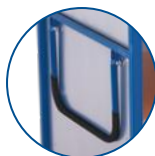

The push/pull bar is flush with the frame when not in use.

Also available in ESD design on page 109

Shelf trolley fixed welded

Article no.	Dimension			Loading surface		Weight kg	Load cap. kg	Wheel diam. mm
	w	mm D	H	w	mm d			
sw-700.412	1115	730	1810	1045	685	123.0	500	200 x 40
sw-800.412	1315	830	1810	1245	785	153.0	500	200 x 40

Load capacity shelf: 80 kg*
EasySTOP swivel castors and foot guards for your safety!

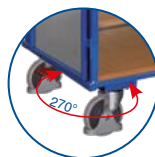

The double wing door opens 270° and is flush with the frame.

Shelf trolley fixed welded

Article no.	Dimension			Loading surface		Weight kg	Load cap. kg	Wheel diam. mm
	w	mm D	H	w	mm d			
sw-700.448	1115	810	1810	1045	685	107.0	500	200 x 40
sw-800.448	1315	910	1810	1245	785	124.0	500	200 x 40

EasySTOP swivel castors and foot guards for your safety!

*Static distributed load; Total load of the transport device must not be exceeded!





The push/pull bar rests on the cross tube when pushing. This ensures that pushing is safe and comfortable.

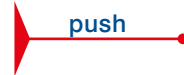

Shelf trolley fixed welded

Article no.	Dimension			Loading surface		Weight	Load cap.	Wheel diam.
	W	D	H	w	d			
sw-700.413	1115	810	1810	1045	685	138.0	500	200 x 40
sw-800.413	1315	910	1810	1245	785	171.5	500	200 x 40

Load capacity shelf: 80 kg*
EasySTOP swivel castors and foot guards for your safety!

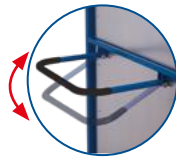

The push/pull bar adjusts to the height of the person pulling when the trolley is being pulled.



Also available in ESD design on page 109

Shelf trolley fixed welded

Article no.	Dimension			Loading surface		Weight	Load cap.	Wheel diam.
	W	D	H	w	d			
sw-700.988	1115	730	1810	1045	685	138.0	500	200 x 40
sw-800.988	1315	830	1810	1245	785	171.5	500	200 x 40

Load capacity shelf: 80 kg*
EasySTOP swivel castors and foot guards for your safety!

Additional articles - Shelves of wood-based board for shelf trolleys

Article no.	Dimension		for loading surface		Weight	Load cap.	
	W	D	w	d			
zsw-700.413	1000	660	1045	685	10.5	80	Additional shelf
zsw-800.413	1200	760	1245	785	14.0	80	



Additional articles - Shelves of plywood for shelf trolleys

Article no.	Dimension		for loading surface		Weight	Load cap.	
	W	D	w	d			
zsw-700.414	1000	660	1045	685	11.0	120	Additional shelf
zsw-800.414	1200	760	1245	785	14.0	120	



Additional articles - Shelves of waterproof bonded plywood, surface finish screen printed for shelf trolleys

Article no.	Dimension		for loading surface		Weight	Load cap.	
	W	D	w	d			
zsw-700.417	1000	660	1045	685	11.0	120	Additional shelf
zsw-800.417	1200	760	1245	760	14.5	120	



*Static distributed load; Total load of the transport device must not be exceeded!



Shelf trolleys with sloping shelves

Shelf trolleys with sloping shelves

Modular system; Base structure with innovative frame section; Load surface and variable shelves of wood-based board, surface finish beech or mesh 50 x 50 mm in angle-steel frame; For sloping or horizontal insertion; Shelf support interval 120 mm, gradient when sloping 15 degrees; Edge 15 mm high; Tubular push bar welded to one end; Trolleys powder-coated RAL 5010 gentian blue; Permanent surface protection; Impact- and scratch-resistant; Grey non-marking thermoplastic rubber tyres on plastic wheel rim with precision deepgroove ball bearings; Thread guard and foot guard; 2 **EasySTOP** swivel castors and 2 fixed castors.

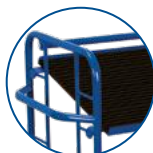

Non-slip covering for suitable shelf trolleys on request

Shelf trolley with 2 wooden shelves

Article no.	Dimension mm			Loading surface mm		Weight kg	Load cap. kg	Wheel diam. mm
	w	D	H	w	d			
sw-540.200	1510	550	1235	1355	550	56.0	250	160 x 40
sw-640.200	1805	650	1275	1650	650	64.5	400	200 x 40

Load capacity shelf: 80 kg*
EasySTOP swivel castors and foot guards for your safety!



Shelf trolley with 3 wooden shelves

Article no.	Dimension mm			Loading surface mm		Weight kg	Load cap. kg	Wheel diam. mm
	w	D	H	w	d			
sw-540.201	1510	550	1535	1355	550	72.0	250	160 x 40
sw-640.201	1805	650	1575	1650	650	87.0	400	200 x 40

Load capacity shelf: 80 kg*
EasySTOP swivel castors and foot guards for your safety!

Shelves for insertion diagonally or horizontal

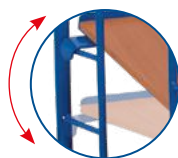

Shelf trolley with 4 wooden shelves

Article no.	Dimension mm			Loading surface mm		Weight kg	Load cap. kg	Wheel diam. mm
	w	D	H	w	d			
sw-540.202	1510	550	1815	1355	550	87.0	250	160 x 40
sw-640.202	1805	650	1855	1650	650	101.5	400	200 x 40

Load capacity shelf: 80 kg*
EasySTOP swivel castors and foot guards for your safety!

Additional articles - Wooden shelves for shelf trolley

Article no.	Dimension mm		for loading surface mm		Weight kg	Load cap. kg	
	w	D	w	d			
zsw-540.202	1320	535	1355	550	12.5	80	Additional shelf
zsw-640.202	1615	635	1650	650	16.0	80	



*Static distributed load; Total load of the transport device must not be exceeded!





Shelf trolley with 2 mesh shelves

Article no.	Dimension			Loading surface		Weight kg	Load cap. kg	Wheel diam. mm
	W	D	H	w	d			
sw-540.223	1510	550	1235	1355	550	47.0	250	160 x 40
sw-640.223	1805	650	1275	1650	650	56.5	400	200 x 40

Load capacity shelf: 50 kg*
EasySTOP swivel castors and foot guards for your safety!



Shelf trolley with 3 mesh shelves

Article no.	Dimension			Loading surface		Weight kg	Load cap. kg	Wheel diam. mm
	W	D	H	w	d			
sw-540.225	1510	550	1535	1355	550	59.5	250	160 x 40
sw-640.225	1805	650	1575	1650	650	66.0	400	200 x 40

Load capacity shelf: 50 kg*
EasySTOP swivel castors and foot guards for your safety!

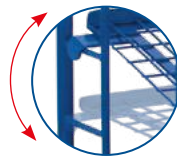

Shelves for insertion
diagonally or horizontal

Shelf trolley with 4 mesh shelves

Article no.	Dimension			Loading surface		Weight kg	Load cap. kg	Wheel diam. mm
	W	D	H	w	d			
sw-540.212	1510	550	1815	1355	550	71.0	250	160 x 40
sw-640.212	1805	650	1855	1650	650	79.0	400	200 x 40

Load capacity shelf: 50 kg*
EasySTOP swivel castors and foot guards for your safety!

Additional articles - Mesh shelves for shelf trolley

Article no.	Dimension		for loading surface		Weight kg	Load cap. kg	
	W	D	w	d			
zsw-540.212	1320	535	1355	550	9.5	50	Additional shelf
zsw-640.212	1615	635	1650	650	10.5	50	

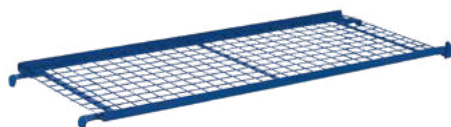

*Static distributed load; Total load of the transport device must not be exceeded!



Shelf trolleys with sloping shelves

Shelf trolleys with sloping shelves

Modular system; Base structure with innovative frame section; Variable shelves of mesh 50 x 50 mm in angle-steel frame; For sloping or horizontal insertion; Shelf support interval 120 mm; Gradient when sloping 15 degrees; Edge 15 mm high; Tubular push bar welded to one end; Trolleys galvanised; Grey non-marking thermoplastic rubber tyres on plastic wheel rim with precision deepgroove ball bearings; Thread guard and foot guard; 2 **EasySTOP** swivel castors and 2 fixed castors.



Shelf trolley with 2 mesh shelves, galvanised

Article no.	Dimension			Loading surface		Weight kg	Load cap. kg	Wheel diam. mm
	W	mm D	H	w	mm d			
sw-540.224	1510	550	1235	1355	550	47.0	250	160 x 40
sw-640.224	1805	650	1275	1650	650	56.5	400	200 x 40

Load capacity shelf: 50 kg*
EasySTOP swivel castors and foot guards for your safety!



Shelf trolley with 3 mesh shelves, galvanised

Article no.	Dimension			Loading surface		Weight kg	Load cap. kg	Wheel diam. mm
	W	mm D	H	w	mm d			
sw-540.226	1510	550	1535	1355	550	59.5	250	160 x 40
sw-640.226	1805	650	1575	1650	650	66.0	400	200 x 40

Load capacity shelf: 50 kg*
EasySTOP swivel castors and foot guards for your safety!

Shelves for insertion diagonally or horizontal

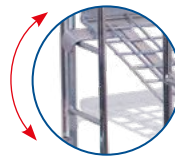

Shelf trolley with 4 mesh shelves, galvanised

Article no.	Dimension			Loading surface		Weight kg	Load cap. kg	Wheel diam. mm
	W	mm D	H	w	mm d			
sw-540.218	1510	550	1815	1355	550	71.0	250	160 x 40
sw-640.218	1805	650	1855	1650	650	79.0	400	200 x 40

Load capacity shelf: 50 kg*
EasySTOP swivel castors and foot guards for your safety!

Additional articles - Galvanised mesh shelves for shelf trolley

Article no.	Dimension		for loading surface		Weight kg	Load cap. kg	Additional shelf
	W	mm D	w	mm d			
zsw-540.218	1320	535	1355	550	9.5	50	
zsw-640.218	1615	635	1650	650	10.5	50	



*Static distributed load; Total load of the transport device must not be exceeded!



Euro container trolleys



Euro container trolleys

Welded steel construction; Screwed; Tilts to 17° or 32° by bolting; Shelves open; Edge 27 mm high; Clearance between cross tubes: 125 mm; Hole spacing for screwing shelves: 150 mm; Suitable for euro boxes 600 x 400 mm (W/D); Trolleys powder-coated RAL 5010 gentian blue; Permanent surface protection; Impact- and scratch-resistant; Grey non-marking thermoplastic rubber tyres on plastic wheel rim with precision deepgroove ball bearings; Thread guard and foot guard; 4 swivel castors, 2 of them with brakes.

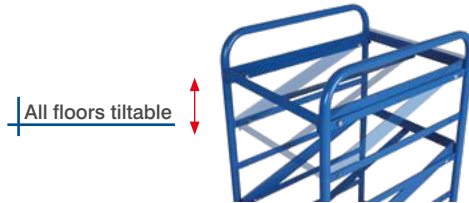

Euro container trolley

Article no.	Dimension			Loading surface		Weight	Load cap.	Wheel diam.
	W	D	H	w	d			
sw-610.100	520	665	1125	410	610	33.5	200	125 x 32

Load capacity shelf: 50 kg*
Swivel castors with wheel brakes and foot guards for your safety!



Euro container trolley

Article no.	Dimension			Loading surface		Weight	Load cap.	Wheel diam.
	W	D	H	w	d			
sw-610.200	935	665	1125	825	610	38.5	200	125 x 32

Load capacity shelf: 50 kg*
Swivel castors with wheel brakes and foot guards for your safety!



Euro container trolley

Article no.	Dimension			Loading surface		Weight	Load cap.	Wheel diam.
	W	D	H	w	d			
sw-610.300	1350	665	1700	1240	610	69.5	250	160 x 40

Load capacity shelf: 50 kg*
Swivel castors with wheel brakes and foot guards for your safety!

*Static distributed load; Total load of the transport device must not be exceeded!

Euro container trolleys

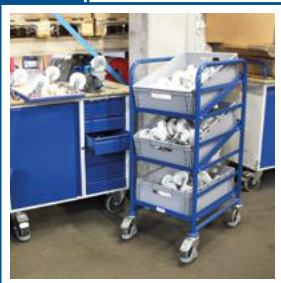

Euro container trolleys

Welded steel construction; Screwed; Tilts to 17° or 32° by bolting; Shelves open with plastic crates (edge 27 mm high) or with wood-based board, surface finish beech (edge 10 mm high); Clearance between cross tubes: 125 mm; Hole spacing for screwing shelves: 150 mm; Suitable for plastic crates 600 x 400 mm (W/D); Pictured with plastic crates 600 x 400 x 170 mm (W/D/H); Trolleys powder-coated RAL 5010 gentian blue; Permanent surface protection; Impact- and scratch-resistant; Grey non-marking thermoplastic rubber tyres on plastic wheel rim with precision deepgroove ball bearings; Thread guard and foot guard; 4 swivel castors, 2 of them with brakes.

Euro container trolley with 3 plastic crates

Article no.	Dimension			Loading surface		Weight kg	Load cap. kg	Wheel diam. mm
	W	D	H	w	d			
sw-610.102	520	665	1160	410	610	38.5	200	125 x 32

Load capacity shelf: 50 kg*

Swivel castors with wheel brakes and foot guards for your safety!

Euro container trolley with 6 plastic crates

Article no.	Dimension			Loading surface		Weight kg	Load cap. kg	Wheel diam. mm
	W	D	H	w	d			
sw-610.202	935	665	1160	825	610	47.5	200	125 x 32

Load capacity shelf: 50 kg*

Swivel castors with wheel brakes and foot guards for your safety!

Euro container trolley with 15 plastic crates

Article no.	Dimension			Loading surface		Weight kg	Load cap. kg	Wheel diam. mm
	W	D	H	w	d			
sw-610.302	1350	665	1785	1240	610	92.0	250	160 x 40

Load capacity shelf: 50 kg*

Swivel castors with wheel brakes and foot guards for your safety!



Additional articles - Plastic crates

Article no.	Dimension			Weight kg	Volume l	Plastic crate
	W	D	H			
fk-040.004	600	400	170	1.5	35	
fk-040.000	600	400	220	3.3	45	

*Static distributed load; Total load of the transport device must not be exceeded!

Euro container trolley with 3 wooden shelves

Article no.	Dimension			Loading surface		Weight	Load cap.	Wheel diam.
	w	D	H	w	d			
sw-610.101	520	665	1125	410	610	40.5	200	125 x 32

Load capacity shelf: 50 kg*
Swivel castors with wheel brakes and foot guards for your safety!



Euro container trolley with 3 wooden shelves

Article no.	Dimension			Loading surface		Weight	Load cap.	Wheel diam.
	w	D	H	w	d			
sw-610.201	935	665	1125	825	610	52.5	200	125 x 32

Load capacity shelf: 50 kg*
Swivel castors with wheel brakes and foot guards for your safety!



Also available in ESD design on page 105

Euro container trolley with 5 wooden shelves

Article no.	Dimension			Loading surface		Weight	Load cap.	Wheel diam.
	w	D	H	w	d			
sw-610.301	1350	665	1700	1240	610	103.0	250	160 x 40

Load capacity shelf: 50 kg*
Swivel castors with wheel brakes and foot guards for your safety!

*Static distributed load; Total load of the transport device must not be exceeded!

Small order-picking trolleys



Small order-picking trolleys

Welded steel construction; Open shelves or with 3 plastic crates (600 x 400 x 220 mm (W/D/H) / 45 l), or of wood-based board, surface finish beech, edge 10 mm high; All small order-picking trolleys suitable for plastic crates 600 x 400 mm (W/D); Middle and upper shelf fixed or tilts to 15° or 30°; Carrying capacity upper and middle shelves: 50 kg; Trolley powder-coated RAL 5010 gentian blue; Permanent surface protection; Impact- and scratch-resistant; Grey non-marking thermoplastic rubber tyres on plastic wheel rim with precision deepgroove ball bearings; Thread guard and foot guard; 2 **EasySTOP** swivel castors and 2 fixed castors.

Small order-picking trolley

Article no.	Dimension			Loading surface		Weight kg	Load cap. kg	Wheel diam. mm
	W	D	H	w	d			
sw-400.800	815	455	1185	610	410	21.0	200	125 x 32

Load capacity shelf: 50 kg*
EasySTOP swivel castors and foot guards for your safety!



Small order-picking trolley with 3 plastic crates

Article no.	Dimension			Loading surface		Weight kg	Load cap. kg	Wheel diam. mm
	W	D	H	w	d			
sw-400.804	815	455	1385	610	410	25.5	200	125 x 32

Load capacity shelf: 50 kg*
EasySTOP swivel castors and foot guards for your safety!

Small order-picking trolley with 3 wooden shelves

Article no.	Dimension			Loading surface		Weight kg	Load cap. kg	Wheel diam. mm
	W	D	H	w	d			
sw-400.801	815	455	1185	610	410	26.0	200	125 x 32

Load capacity shelf: 50 kg*
EasySTOP swivel castors and foot guards for your safety!



*Static distributed load; Total load of the transport device must not be exceeded!



All floors tiltable



Small order-picking trolley, tiltable

Article no.	Dimension mm			Loading surface mm		Weight kg	Load cap. kg	Wheel diam. mm
	W	D	H	w	d			
sw-400.802	815	455	1185	610	410	22.0	200	125 x 32

Load capacity shelf: 50 kg*
EasySTOP swivel castors and foot guards for your safety!

Plastic crates on page 136

Small order-picking trolley with 3 plastic crates, tiltable

Article no.	Dimension mm			Loading surface mm		Weight kg	Load cap. kg	Wheel diam. mm
	W	D	H	w	d			
sw-400.805	815	455	1385	610	410	28.5	200	125 x 32

Load capacity shelf: 50 kg*
EasySTOP swivel castors and foot guards for your safety!



Also available in ESD design on page 105

Small order-picking trolley with 3 wooden shelves, tiltable

Article no.	Dimension mm			Loading surface mm		Weight kg	Load cap. kg	Wheel diam. mm
	W	D	H	w	d			
sw-400.803	815	455	1185	610	410	29.5	200	125 x 32

Load capacity shelf: 50 kg*
EasySTOP swivel castors and foot guards for your safety!

*Static distributed load; Total load of the transport device must not be exceeded!

Material stands

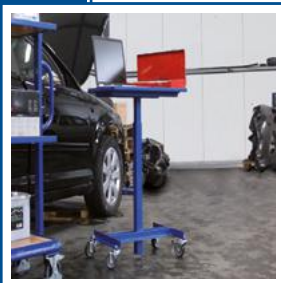

Material stands

Welded steel construction; Load surface with 22 mm high edge on one side or 18 mm high edge on all sides; Height adjustment range 500-755, 515-790, 695-1,065 or 750-1,000 mm in steps of 25 mm; Suitable for plastic crates 600 x 400 mm (W/D); Load surfaces fixed or one-sided tilts to 15° or 30°; Secure positioning by spring catch; Material stands powder-coated RAL 5010 gentian blue; Permanent surface protection; Impact- and scratch-resistant; Grey non-marking thermoplastic rubber tyres on plastic wheel rim with precision deepgroove ball bearings; Thread guard and foot guard; 4 swivel castors, 2 of them with brakes.



Also available in ESD design on page 101

Material stand

Article no.	Dimension mm			Loading surface mm		Weight kg	Load cap. kg	Wheel diam. mm
	W	D	H	w	d			
sw-405.000	610	410	770-1020	605	405	16.0	150	75 x 25

Swivel castors with wheel brakes!

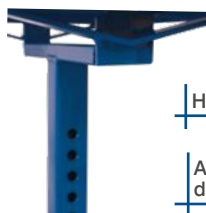

Height adjustment in steps of 25 mm

Also available in ESD design on page 101

Material stand

Article no.	Dimension mm			Loading surface mm		Weight kg	Load cap. kg	Wheel diam. mm
	W	D	H	w	d			
sw-405.001	610	410	535-810	605	405	14.5	150	75 x 25

Swivel castors with wheel brakes!

Also available in ESD design on page 101



Material stand, one-sided tiltable

Article no.	Dimension mm			Loading surface mm		Weight kg	Load cap. kg	Wheel diam. mm
	W	D	H	w	d			
sw-405.002	600	410	715-1085	510	410	15.0	150	75 x 25

Swivel castors with wheel brakes!



Also available in ESD design on page 101

Material stand, one-sided tiltable

Article no.	Dimension mm			Loading surface mm		Weight kg	Load cap. kg	Wheel diam. mm
	W	D	H	w	d			
sw-405.005	600	410	520-775	510	410	13.5	150	75 x 25

Swivel castors with wheel brakes!



Material stand with hand crank

Welded steel construction; Load surface with edge on one side, 22 mm high; Platform bolted to frame, permitting variable extension with other types of platform; Zero-play adjustable telescopic system, self-locking; Continuously adjustable by hand crank; Height adjustment range 660 - 1,035 mm; Platform height adjustable even under full load; Load surfaces one-sided tilts to 15° or 30°; Material stand powder-coated RAL 5010 gentian blue; Permanent surface protection; Impact- and scratch-resistant; Grey non-marking thermoplastic rubber tyres on plastic wheel rim with precision deepgroove ball bearings; Thread guard and foot guard; 4 swivel castors, 2 of them with brakes.



Material stand with hand crank

Article no.	Dimension			Loading surface		Weight kg	Load cap. kg	Wheel diam. mm
	w	D	H	w	d			
sw-405.012	600	415	680-1055	510	410	19.0	150	75 x 25

Swivel castors with wheel brakes!

Document trolleys and book trolley



Document trolley

Welded tubular steel construction; Document compartment enclosed on 3 sides; End and side wall height: 505 mm; Load surface inclined at 10° towards back; 1 push bar at each end; Trolley powder-coated RAL 5010 gentian blue; Permanent surface protection; Impact- and scratch-resistant; Grey non-marking thermoplastic rubber tyres on plastic wheel rim with precision deepgroove ball bearings; Thread guard and foot guard; 4 swivel castors with brakes.

Document trolley

Article no.	Dimension mm			Loading surface mm			Weight kg	Load cap. kg	Wheel diam. mm
	W	D	H	w	d	h			
sw-500.380	625	550	1025	550	500	420	25.0	100	100 x 32

Swivel castors with wheel brakes!

Document trolley with 12 compartments

Robust angle-steel construction; 6 compartments on each side; Superstructure and compartments of waterproof bonded plywood; Surface finish screen printed tilt 9°; With 2 top push bars; Base frame with surrounding protective strip of plastic profile; Trolley powder-coated RAL 5010 gentian blue; Permanent surface protection; Impact- and scratch-resistant; Grey non-marking thermoplastic rubber tyres on plastic wheel rim with precision deepgroove ball bearings; Thread guard and foot guard; 2 **EasySTOP** swivel castors and 2 fixed castors.



Compartments:
W=340 x D=320 x H=345 mm

Document trolley with 12 compartments

Article no.	Dimension mm			Loading surface mm	Weight kg	Load cap. kg	Wheel diam. mm
	W	D	H				
sw-700.995	1105	700	1185	2 x 6 compartments	66.5	400	200 x 40

Load capacity shelf: 30 kg*

EasySTOP swivel castors and foot guards for your safety!

Book trolley

Welded steel construction; 3 sloping shelves for transport and storage of books; Tilt 5°; Vertical distance between shelves 300 mm; 1 push bar at each end; Trolley powder-coated RAL 5010 gentian blue; Permanent surface protection; Impact- and scratch-resistant; Grey non-marking thermoplastic rubber tyres on plastic wheel rim with precision deepgroove ball bearings; Thread guard; 4 swivel castors, 2 of them with brakes.

Book trolley

Article no.	Dimension mm			Loading surface mm		Weight kg	Load cap. kg	Wheel diam. mm
	W	D	H	w	d			
sw-300.000	1085	300	900	830	265	26.0	150	75 x 25

Load capacity shelf: 50 kg*

Swivel castors with wheel brakes!



*Static distributed load; Total load of the transport device must not be exceeded!



Document trolley with 20 compartments

Welded steel construction; With 10 compartments at each end; Shelves of waterproof bonded plywood, surface finish screen printed; Tilt 5°; Width of compartments: 305 mm; Depth of compartments: 345 mm; Height of compartments: 330 mm; Central wall with mesh 50 x 100 mm; Side walls of perforated sheet; With 2 vertical push bars (projecting 100 mm); Base frame with surrounding protective strip of plastic profile; Trolley powder-coated RAL 5010 gentian blue; Permanent surface protection; Impact- and scratch-resistant; Grey non-marking thermoplastic rubber tyres on plastic wheel rim with precision deepgroove ball bearings; Thread guard and foot guard; 2 **EasySTOP** swivel castors and 2 fixed castors.



Compartments:
W=305 x D=345 x H=330 mm

Document trolley with 20 compartments

Article no.	Dimension			Loading surface mm	Weight kg	Load cap. kg	Wheel diam. mm
	W	D	H				
sw-574.002	690	860	2015	2 x 10 compartments	69.0	500	160 x 40

Load capacity shelf: 25 kg*
EasySTOP swivel castors and foot guards for your safety!



Document trolley with 9 compartments

Robust angle-steel construction; 9 compartments for files; Superstructure and compartments of wood-based board, surface finish beech; Width of compartment: 250 mm, height of compartments: 330 mm; Compartments can be closed by roller shutter with cylinder lock; Recessed handle at end; Base frame with surrounding protective strip of plastic profile; Trolley powder-coated RAL 5010 gentian blue; Permanent surface protection; Impact- and scratch-resistant; Grey non-marking thermoplastic rubber tyres on plastic wheel rim with precision deepgroove ball bearings; Thread guard and foot guard; 2 **EasySTOP** swivel castors and 2 fixed castors.

Compartments:
W=250 x D=400 x H=330 mm

Document trolley with 9 compartments, lockable

Article no.	Dimension			Loading surface	Weight kg	Load cap. kg	Wheel diam. mm
	w	D	H				
sw-474.000	875	490	1460	9 compartments	76.0	400	160 x 40

Load capacity shelf: 50 kg*
EasySTOP swivel castors and foot guards for your safety!



VARIOfit

*Static distributed load; Total load of the transport device must not be exceeded!



Order-picking trolleys with additional articles

Order-picking trolley

Welded steel construction; Load surface, end and side walls and roof with mesh sides 50 x 100 mm; Horizontal push bar painted RAL 2008 bright red orange; With document pocket DIN A4 across; 2 sheets for table; Galvanised; Grey non-marking thermoplastic rubber tyres on plastic wheel rim with precision deepgroove ball bearings; Thread guard and foot guard; 2 swivel castors with wheel brakes and 2 fixed castors.



Load surface use for Euro size containers

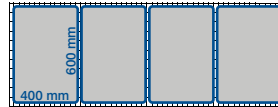

Order-picking trolley, galvanised

Article no.	Dimension			Loading surface		Weight kg	Load cap. kg	Wheel diam. mm
	w	mm D	H	w	d			
sw-520.200	1860	650	1850	1675	615	86.5	300	125 x 32

Swivel castors with wheel brakes and foot guards for your safety!

Order-picking trolley

Welded steel construction; Load surface, end and side walls and roof with mesh sides 100 x 50 mm; 2 vertical push bars painted RAL 2008 bright red orange; With document pocket DIN A4 across; Galvanised; Grey non-marking thermoplastic rubber tyres on plastic wheel rim with precision deepgroove ball bearings; Thread guard and foot guard; 2 swivel castors with wheel brakes and 2 fixed castors.

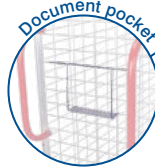

Load surface use for Euro size containers

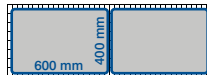

Order-picking trolley, galvanised

Article no.	Dimension			Loading surface		Weight kg	Load cap. kg	Wheel diam. mm
	w	mm D	H	w	d			
sw-490.100	1435	490	1820	1250	460	43.5	300	125 x 32

Swivel castors with wheel brakes and foot guards for your safety!

Additional articles

Additional article - EasySTOP central brake

Article no.
rsa-125.500

As ex-factory equipment



Additional article - EasySTOP central brake accessible from both sides

Article no.	
rsa-000.050	2 brakes applied
rsa-000.051	4 brakes applied

As ex-factory equipment

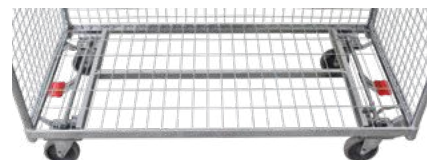

Special needs require special solutions . . .



You have the opportunity here to adapt the order-picking trolley to your processes. Configure it to your liking and to your requirements.



Additional article - Coupling and drawbar

Article no.	Weight
rsa-000.060	

As ex-factory equipment



Additional article - Middle wheel (enables turning on the spot)

Article no.	Weight
rsa-125.600	1.5

As ex-factory equipment



Additional article - 3-tread steps

Article no.	Weight
zsw-200.000	8.5

As ex-factory equipment



Additional article - Push and pull bar

Article no.	Weight
zsw-100.004	1.2



Additional article - Drinks holder

Article no.	Weight
zsw-100.001	0.3



Additional article - Plastic divider

Article no.	Weight
zsw-490.103	1.4
zsw-520.203	1.7

Additional article - Shelves of wire mesh base, replaceable

Article no.	Weight
zsw-490.100	4.5
zsw-520.200	5.5

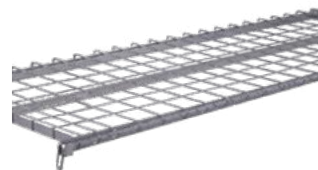

Additional article - Shelves of sheet steel base, replaceable

Article no.	Weight
zsw-490.102	5.5
zsw-520.202	6.5



Additional article - Shelves of waterproof bonded plywood, surface finish screen printed, replaceable

Article no.	Weight
zsw-490.106	10.0
zsw-520.206	11.0



Additional article - Shelves of wire mesh base with scanner rail, replaceable

Article no.	Weight
zsw-490.101	6.5
zsw-520.201	8.0



Additional article - Clothes rail

Article no.	Weight
zsw-490.104	1.5
zsw-520.204	1.5



Additional article - Front wall

Article no.	Weight
zsw-490.105	7.5
zsw-520.205	8.5

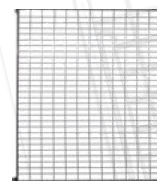

Hand trucks



Hand trucks

Welded steel construction; With reflective films; Screwed hand drawer with plastic handles and stand; Load surface and optional side walls of waterproof bonded plywood, surface finish screen printed, anti-slip; Hand trucks powder-coated RAL 5010 gentian blue; Permanent surface protection; Impact- and scratch-resistant; Pneumatic or solid-rubber tyres on steel wheel rim, solid-rubber tyres with diameter 260 x 65 mm on special plastic wheel rim with precision deepgroove ball bearings.



Hand truck without side walls

Article no.		Dimension			Loading surface		Weight kg	Load cap. kg	Wheel diam. mm
		W	mm D	H	w mm	d			
zu-1290	P	1560	685	780	785	435	19.0	200	260 x 85
zu-1291	P	1600	810	860	825	535	25.5	400	400 x 100
zu-1292	P	1900	810	860	1125	535	28.5	400	400 x 100
zu-1278	P	1770	910	860	1000	635	30.0	400	400 x 100

P = Pneumatic tyres



Hand truck without side walls

Article no.		Dimension			Loading surface		Weight kg	Load cap. kg	Wheel diam. mm
		W	mm D	H	w mm	d			
zu-1276	SR	1560	645	780	785	435	21.0	200	260 x 65
zu-1277	SR	1600	770	860	825	535	38.0	400	400 x 80
zu-1263	SR	1900	770	860	1125	535	41.5	400	400 x 80
zu-1264	SR	1770	870	860	1000	635	43.0	400	400 x 80

SR = Solid-rubber tyres

Hand truck with side walls

Article no.		Dimension			Loading surface		Weight kg	Load cap. kg	Wheel diam. mm
		W	mm D	H	w mm	d			
zu-1280	P	1560	685	780	765	435	22.0	200	260 x 85
zu-1281	P	1600	810	860	805	535	28.0	400	400 x 100
zu-1282	P	1900	810	860	1105	535	32.5	400	400 x 100
zu-1279	P	1770	910	860	975	635	33.5	400	400 x 100

P = Pneumatic tyres



Hand truck with side walls

Article no.		Dimension			Loading surface		Weight kg	Load cap. kg	Wheel diam. mm
		W	mm D	H	w mm	d			
zu-1284	SR	1560	645	780	765	435	24.0	200	260 x 65
zu-1283	SR	1600	770	860	805	535	41.0	400	400 x 80
zu-1285	SR	1900	770	860	1105	535	45.5	400	400 x 80
zu-1272	SR	1770	870	860	975	635	47.0	400	400 x 80

SR = Solid-rubber tyres



Lightweight hand truck, roll truck and roll stand

Lightweight hand truck

Welded steel construction; Railing 220 mm high; With reflective films; Screwed hand drawer with plastic handles and stand; Load surface and side walls of waterproof bonded plywood, surface finish screen printed, anti-slip; Lightweight hand truck powder-coated RAL 5010 gentian blue; Permanent surface protection; Impact- and scratch-resistant; Pneumatic tyres on plastic wheel rim with precision deepgroove ball bearings.

Lightweight hand truck

Article no.		Dimension			Loading surface		Weight	Load cap.	Wheel diam.
		w	mm D	H	w	d			
zu-1181	P	1575	625	765	690	425	16.0	150	310 x 55

P = Pneumatic tyres



Roll truck

Welded steel construction; Pull bar with horizontal handle; Screwed; Mountable on the right or left side; Roll truck powder-coated RAL 5010 gentian blue; Permanent surface protection; Impact- and scratch-resistant; Pneumatic tyres on steel wheel rim with precision deepgroove ball bearings.

Roll truck

Article no.		Dimension			Loading surface		Weight	Load cap.	Wheel diam.
		w	mm D	H	w	d			
sk-1310	P	2700	865	840	1590	575	32.0	400	400 x 100

P = Pneumatic tyres

Drawbar can be fitted right and left

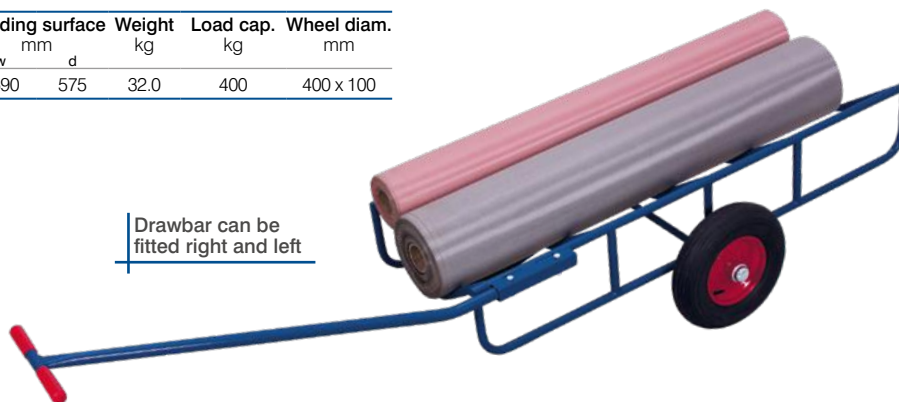

Roll stand

Welded steel construction; Chrome-plated loading bar; Loading height: 800 mm; Roll stand painted RAL 5012 light blue; 4 feet.

Roll stand

Article no.	Dimension			Weight	Load cap.
	w	mm D	H		
sg-100.011	1830	1010	1210	20.5	100

Bicycle trailers

Bicycle trailers

Welded steel construction; With reflective films; All bicycle trailers are supplied with complete trailer coupling and plastic handles; The ball socket is welded to the towbar; The ball head with clamp is supplied loose for the user to fit to the cycle frame; Universal fitting for saddle tubes from 26 mm - 31 mm; Maximum load: 40 kg; Lean load: 4 kg; Load surface and optional side walls of waterproof bonded plywood, surface finish screen printed, anti-slip; Trailer powder-coated RAL 5010 gentian blue; Permanent surface protection; Impact- and scratch-resistant; Pneumatic tyres on steel wheel rim with precision deepgroove ball bearings.



Including trailer coupling

Bicycle trailer without side walls

Article no.		Dimension			Loading surface		Weight kg	Load cap. kg	Wheel diam. mm
		W	mm D	H	w	mm d			
zu-1380	P	1795	685	735	785	435	20.0	200	260 x 85
zu-1381	P	1835	810	810	825	535	24.0	400	400 x 100
zu-1382	P	2135	810	810	1125	535	28.5	400	400 x 100

P = Pneumatic tyres

Bicycle trailer only for internal material-transport



Bicycle trailer with side walls

Article no.		Dimension			Loading surface		Weight kg	Load cap. kg	Wheel diam. mm
		W	mm D	H	w	mm d			
zu-1390	P	1795	685	735	765	435	23.0	200	260 x 85
zu-1391	P	1835	810	860	805	535	29.5	400	400 x 100
zu-1392	P	2135	810	860	1105	535	34.0	400	400 x 100

P = Pneumatic tyres

Lightweight bicycle trailer

Welded steel construction; Railing 220 mm high; With reflective films; All bicycle trailers are supplied with complete trailer coupling and plastic handles; The ball socket is welded to the towbar; The ball head with clamp is supplied loose for the user to fit to the cycle frame; Load surface and side walls of waterproof bonded plywood, surface finish screen printed, anti-slip; Trailer powder-coated RAL 5010 gentian blue; Permanent surface protection; Impact- and scratch-resistant; Pneumatic tyres on plastic wheel rim with precision deepgroove ball bearings.



Lightweight bicycle trailer

Article no.		Dimension			Loading surface		Weight kg	Load cap. kg	Wheel diam. mm
		W	mm D	H	w	mm d			
zu-1180	P	1595	625	765	590	425	16.0	150	310 x 55

P = Pneumatic tyres

Hand platform trolleys

Hand platform trolleys

Welded steel construction; With reflective films; Optional side walls with fastener; 3 sides foldable; Height of side wall: 210 mm; Safety handles of drawbar with soft plastic grip cover black; With turntable steering and ball bearing steering rings; Automatic parking brake acting on front wheels; Automatically damped return to rest position; Load surface and optional side walls of waterproof bonded plywood, surface finish screen printed, anti-slip; Hand platform trolleys powder-coated RAL 5010 gentian blue; Permanent surface protection; Impact- and scratch-resistant; Pneumatic or solid-rubber tyres on steel wheel rim, solid-rubber tyres with diameter 260 x 65 mm on special plastic wheel rim with precision deepgroove ball bearings.

Hand platform trolley without side walls

Article no.		Dimension			Loading surface		Weight kg	Load cap. kg	Wheel diam. mm
		w	mm D	H	w	mm d			
zu-05102	P	1120	700	1200	1000	700	47.5	700	260 x 85
zu-05101	SR	1120	700	1200	1000	700	51.0	700	260 x 65
zu-05122	P	1320	800	1200	1200	800	53.0	700	260 x 85
zu-05121	SR	1320	800	1200	1200	800	57.0	700	260 x 65

P = Pneumatic tyres, SR = Solid-rubber tyres



Hand platform trolley without side walls

Article no.		Dimension			Loading surface		Weight kg	Load cap. kg	Wheel diam. mm
		w	mm D	H	w	mm d			
zu-05132	P	1265	800	1340	1200	800	62.0	1000	400 x 100
zu-05131	SR	1265	800	1340	1200	800	88.5	1000	400 x 80
zu-05162	P	1665	800	1340	1600	800	68.5	1000	400 x 100
zu-05161	SR	1665	800	1340	1600	800	95.0	1000	400 x 80
zu-05202	P	2065	1000	1340	2000	1000	84.0	1000	400 x 100
zu-05201	SR	2065	1000	1340	2000	1000	110.0	1250	400 x 80

P = Pneumatic tyres, SR = Solid-rubber tyres



Hand platform trolley with side walls

Article no.		Dimension			Loading surface		Weight kg	Load cap. kg	Wheel diam. mm
		w	mm D	H	w	mm d			
zu-15102	P	1135	730	1200	985	680	68.5	700	260 x 85
zu-15101	SR	1135	730	1200	985	680	72.5	700	260 x 65
zu-15122	P	1335	830	1200	1185	780	76.0	700	260 x 85
zu-15121	SR	1335	830	1200	1185	780	79.5	700	260 x 65

P = Pneumatic tyres, SR = Solid-rubber tyres



Hand platform trolley with side walls

Article no.		Dimension			Loading surface		Weight kg	Load cap. kg	Wheel diam. mm
		w	mm D	H	w	mm d			
zu-15132	P	1280	830	1340	1185	780	85.0	1000	400 x 100
zu-15131	SR	1280	830	1340	1185	780	111.0	1000	400 x 80
zu-15162	P	1680	830	1340	1585	780	93.5	1000	400 x 100
zu-15161	SR	1680	830	1340	1585	780	120.0	1000	400 x 80
zu-15202	P	2080	1030	1340	1985	980	112.0	1000	400 x 100
zu-15201	SR	2080	1030	1340	1985	980	138.5	1250	400 x 80

P = Pneumatic tyres, SR = Solid-rubber tyres

Hand platform trolleys

Hand platform trolleys

Welded steel construction; With reflective films; Removable side walls of tubular grid; End walls screwed; Side walls suspended; Height of tubular grid walls: 755 mm; Safety handles of drawbar with soft plastic grip cover black; With turntable steering and ball bearing steering rings; Automatic parking brake acting on front wheels; Automatically damped return to rest position; Load surface of waterproof bonded plywood, surface finish screen printed, anti-slip; Hand platform trolleys powder-coated RAL 5010 gentian blue; Permanent surface protection; Impact- and scratch-resistant; Pneumatic or solid-rubber tyres on steel wheel rim, solid-rubber tyres with diameter 260 x 65 mm on special plastic wheel rim with precision deepgroove ball bearings.



Hand platform trolley with 2 tubular grid side walls

Article no.		Dimension			Loading surface		Weight kg	Load cap. kg	Wheel diam. mm
		W	mm D	H	w	d			
zu-42120	P	1120	715	1200	940	700	61.0	700	260 x 85
zu-42119	SR	1120	715	1200	940	700	65.0	700	260 x 65
zu-42122	P	1320	815	1200	1140	800	67.5	700	260 x 85
zu-42121	SR	1320	815	1200	1140	800	71.0	700	260 x 65

P = Pneumatic tyres, SR = Solid-rubber tyres



Hand platform trolley with 2 tubular grid side walls

Article no.		Dimension			Loading surface		Weight kg	Load cap. kg	Wheel diam. mm
		W	mm D	H	w	d			
zu-42132	P	1265	815	1340	1140	800	76.5	1000	400 x 100
zu-42131	SR	1265	815	1340	1140	800	103.0	1000	400 x 80
zu-42162	P	1665	815	1340	1540	800	83.0	1000	400 x 100
zu-42161	SR	1665	815	1340	1540	800	109.5	1000	400 x 80
zu-42202	P	2065	1015	1340	1940	1000	99.5	1000	400 x 100
zu-42201	SR	2065	1015	1340	1940	1000	126.0	1250	400 x 80

P = Pneumatic tyres, SR = Solid-rubber tyres

Hand platform trolley with 4 tubular grid side walls

Article no.		Dimension			Loading surface		Weight kg	Load cap. kg	Wheel diam. mm
		W	mm D	H	w	d			
zu-45102	P	1120	715	1200	940	640	74.0	700	260 x 85
zu-45101	SR	1120	715	1200	940	640	78.0	700	260 x 65
zu-45122	P	1320	815	1200	1140	740	82.0	700	260 x 85
zu-45121	SR	1320	815	1200	1140	740	86.0	700	260 x 65

P = Pneumatic tyres, SR = Solid-rubber tyres



Hand platform trolley with 4 tubular grid side walls

Article no.		Dimension			Loading surface		Weight kg	Load cap. kg	Wheel diam. mm
		W	mm D	H	w	d			
zu-45132	P	1265	815	1340	1140	740	91.0	1000	400 x 100
zu-45131	SR	1265	815	1340	1140	740	117.5	1000	400 x 80
zu-45162	P	1665	815	1340	1540	740	103.0	1000	400 x 100
zu-45161	SR	1665	815	1340	1540	740	129.5	1000	400 x 80
zu-45202	P	2065	1015	1340	1940	940	123.0	1000	400 x 100
zu-45201	SR	2065	1015	1340	1940	940	149.0	1250	400 x 80

P = Pneumatic tyres, SR = Solid-rubber tyres



Automatic parking brake acting on front wheels and drawbar with safety handle; Braking point and braking effect manually adjustable; Automatically damped return to rest position; Big fastener for simple and safely locking of walls; Red and white reflective films. All manual platform trucks can be extended with a towing eye and/or coupling hitch. It is therefore possible to move the manual platform truck using a tractor unit, either individually or in a train.

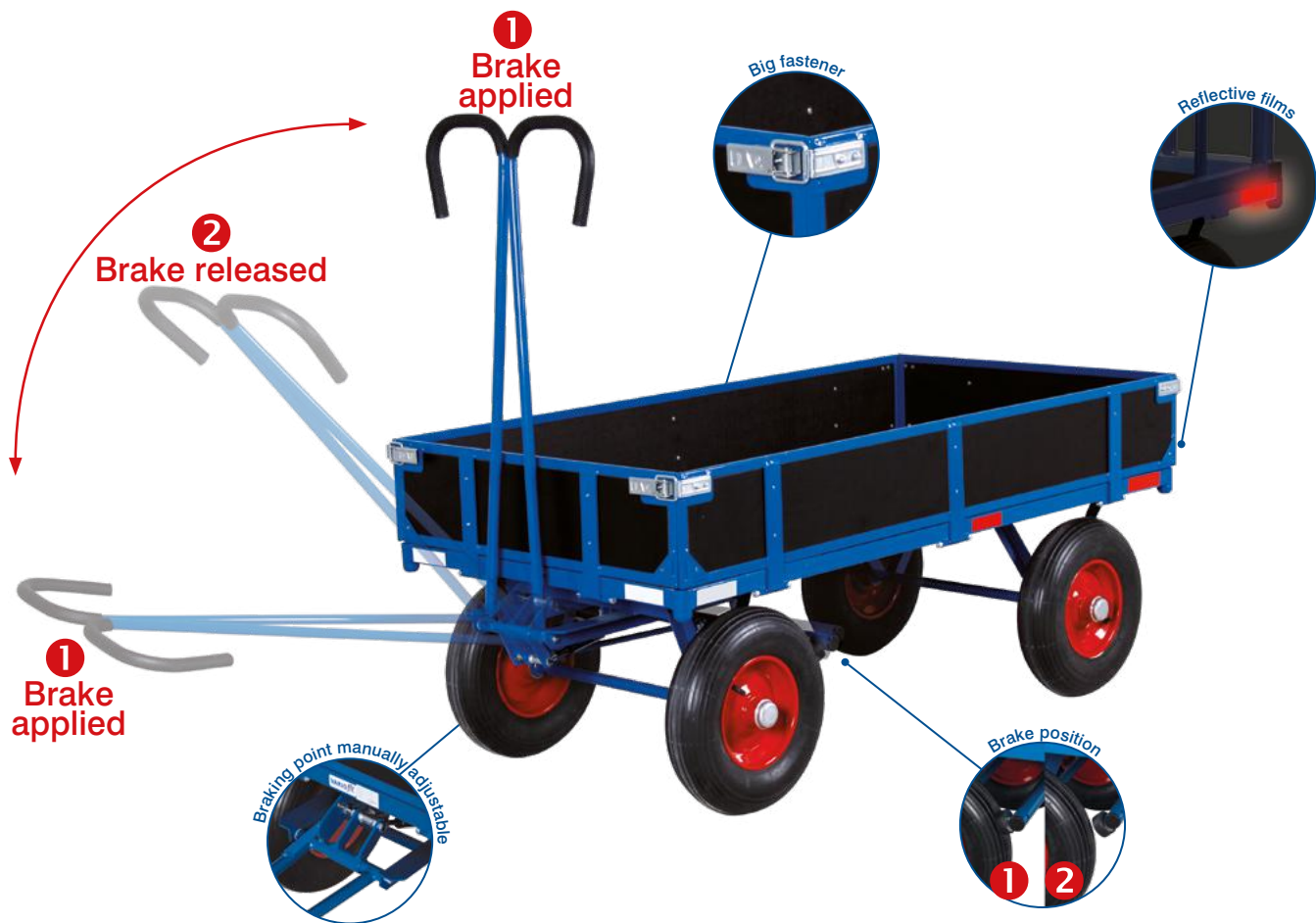

Additional articles for hand platform trolleys

Article no.	
01-1030	Drawbar eye on drawbar
01-1031	Coupling at the end
As ex-factory equipment	



Automatic locking of drawbar eye. Protection against unlocking by spring mechanism.

Industrial trailers

1-axle turnable steering



Industrial trailer with 1-axle turnable steering

Article no.		Loading surface		Loading height mm	Weight kg	Load cap. kg	Wheel diam. mm
		w mm	d mm				
zu-1002	P	2000	1000	540	270.0	2000	410 x 110
zu-1001	SR	2000	1000	510	285.0	2000	360 x 60
zu-1004	P	2500	1250	540	315.0	2000	410 x 110
zu-1003	SR	2500	1250	510	335.0	2000	360 x 60
zu-1006	P	3000	1500	540	375.0	2000	410 x 110
zu-1005	SR	3000	1500	510	390.0	2000	360 x 60
zu-1008	P	2000	1000	560	270.0	3000	460 x 140
zu-1007	SR	2000	1000	530	285.0	3000	400 x 75
zu-1010	P	2500	1250	560	320.0	3000	460 x 140
zu-1009	SR	2500	1250	530	335.0	3000	400 x 75
zu-1012	P	3000	1500	560	375.0	3000	460 x 140
zu-1011	SR	3000	1500	530	390.0	3000	400 x 75
zu-1014	P	2000	1000	700	310.0	5000	530 x 160
zu-1013	SR	2000	1000	530	315.0	5000	400 x 130
zu-1016	P	2500	1250	700	350.0	5000	530 x 160
zu-1015	SR	2500	1250	530	355.0	5000	400 x 130
zu-1018	P	3000	1500	700	395.0	5000	530 x 160
zu-1017	SR	3000	1500	530	400.0	5000	400 x 130
zu-1019	SR	2500	1250	540	335.0	8000	415 x 200
zu-1020	SR	3000	1500	540	425.0	8000	415 x 200
zu-1021	SR	4000	2000	540	560.0	8000	415 x 200
zu-1022	SR	5000	2000	540	585.0	8000	415 x 200

P = Pneumatic tyres, SR = Solid-rubber tyres

2-axle turnable steering



Industrial trailer with 2-axle turnable steering

Article no.		Loading surface		Loading height mm	Weight kg	Load cap. kg	Wheel diam. mm
		w mm	d mm				
zu-1032	P	2000	1000	540	285.0	2000	410 x 110
zu-1031	SR	2000	1000	510	300.0	2000	360 x 60
zu-1034	P	2500	1250	540	335.0	2000	410 x 110
zu-1033	SR	2500	1250	510	350.0	2000	360 x 60
zu-1036	P	3000	1500	540	390.0	2000	410 x 110
zu-1035	SR	3000	1500	510	405.0	2000	360 x 60
zu-1038	P	2000	1000	560	285.0	3000	460 x 140
zu-1037	SR	2000	1000	530	300.0	3000	400 x 75
zu-1040	P	2500	1250	560	335.0	3000	460 x 140
zu-1039	SR	2500	1250	530	350.0	3000	400 x 75
zu-1042	P	3000	1500	560	395.0	3000	460 x 140
zu-1041	SR	3000	1500	530	405.0	3000	400 x 75
zu-1044	P	2000	1000	700	325.0	5000	530 x 160
zu-1043	SR	2000	1000	530	330.0	5000	400 x 130
zu-1046	P	2500	1250	700	365.0	5000	530 x 160
zu-1045	SR	2500	1250	530	370.0	5000	400 x 130
zu-1048	P	3000	1500	700	410.0	5000	530 x 160
zu-1047	SR	3000	1500	530	415.0	5000	400 x 130

P = Pneumatic tyres, SR = Solid-rubber tyres

Industrial trailer with 4-axle turnable steering

Article no.		Loading surface		Loading height mm	Weight kg	Load cap. kg	Wheel diam. mm
		w mm	d mm				
zu-4050	P	2000	1000	540	265.0	2000	410 x 110
zu-4049	SR	2000	1000	510	280.0	2000	360 x 60
zu-4052	P	2500	1250	540	315.0	2000	410 x 110
zu-4051	SR	2500	1250	510	330.0	2000	360 x 60
zu-4054	P	3000	1500	540	370.0	2000	410 x 110
zu-4053	SR	3000	1500	510	385.0	2000	360 x 60
zu-4056	P	2000	1000	560	265.0	3000	460 x 140
zu-4055	SR	2000	1000	530	280.0	3000	400 x 75
zu-4058	P	2500	1250	560	315.0	3000	460 x 140
zu-4057	SR	2500	1250	530	330.0	3000	400 x 75
zu-4060	P	3000	1500	560	370.0	3000	460 x 140
zu-4059	SR	3000	1500	530	385.0	3000	400 x 75
zu-4062	P	2000	1000	700	305.0	5000	530 x 160
zu-4061	SR	2000	1000	530	310.0	5000	400 x 130
zu-4064	P	2500	1250	700	345.0	5000	530 x 160
zu-4063	SR	2500	1250	530	350.0	5000	400 x 130
zu-4066	P	3000	1500	700	390.0	5000	530 x 160
zu-4065	SR	3000	1500	530	395.0	5000	400 x 130

P = Pneumatic tyres, SR = Solid-rubber tyres

4-axle turnable steering



Industrial trailers

Extremely robust, pulse-welded steel-section construction; With rounded corners; The steering system is of turntable design with heavy-duty precision deepgroove ball bearings; Steering ring with safety stop in accordance with German accident prevention regulations (UVV); Maximum speed: 6 km/h; Trailers painted RAL 2004 pure orange; Welded drawbar with retaining system in accordance with German accident prevention regulations (UVV); Standard drawbar eye for 35 mm coupling bolts (offset drawbars or drawbars with swivel eyes also available on request); Compatible towing hitch height: 400 - 600 mm; Caution: if the customer does not specify the height of the drawbar jaw, we accept no liability for ease of coupling of the trailer; Load surface of waterproof bonded plywood, surface finish screen printed, anti-slip; Heavy-duty wheels in robust welded-steel construction with elastic solid-rubber tyres or heavy-duty pneumatic wheels with industrial tread; The hubs are fitted with dustproof encapsulated, pre-lubricated bearings in accordance with DIN ISO 355 or 15-1981.

**Additional article - Four push-fit stanchions;
Usable length: 600 mm**

Article no.	
zu-1069	Four push-fit stanchions

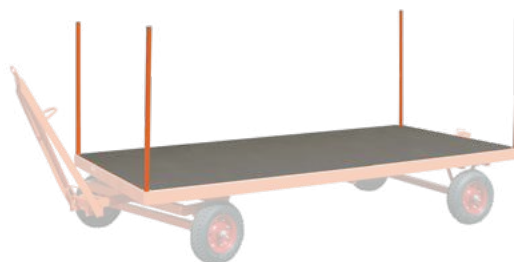

Additional article - 4 side walls, 400 mm high, 2 sides foldable; Front wall fixed but removable; 4 locks

Article no.	for loading surface		
	w	d	
zu-1060	2000	1000	Four side walls, 400 mm high
zu-1061	2500	1250	
zu-1062	3000	1500	

As ex-factory equipment
not additionally mountable

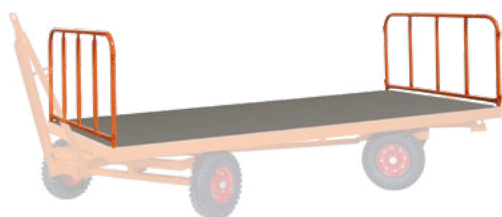

Additional article - 2 tubular-steel end walls, 750 mm high, removable

Article no.	for loading surface		
	w	d	
zu-1063	2000	1000	Two tubular-steel walls, 750 mm high
zu-1064	2500	1250	
zu-1065	3000	1500	

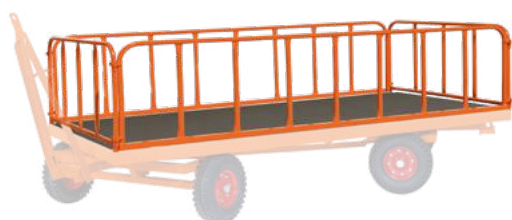

Additional article - 4 tubular-steel walls, 750 mm high, removable, sides insertable

Article no.	for loading surface		
	w	d	
zu-1066	2000	1000	Four tubular-steel walls, 750 mm high
zu-1067	2500	1250	
zu-1068	3000	1500	

Crate dollies



Crate dollies

Welded steel construction; Load surface open or of wood-based board, surface finish beech or with ribbed rubber covering, or with diamond-tread; Dollies powder-coated RAL 5010 gentian blue; Permanent surface protection; Impact- and scratch-resistant; Grey non-marking thermoplastic rubber tyres on plastic wheel rim with precision deepgroove ball bearings; Thread guard and foot guard; 4 swivel castors, 2 of them with brakes.



Crate dolly

Article no.	Dimension mm			Loading surface mm		Weight kg	Load cap. kg	Wheel diam. mm
	w	D	H	w	d			
sw-500.010	500	500	170	500	500	8.5	400	125 x 32

Swivel castors with wheel brakes and foot guards for your safety!



Crate dolly with board load surface

Article no.	Dimension mm			Loading surface mm		Weight kg	Load cap. kg	Wheel diam. mm
	w	D	H	w	d			
sw-500.011	500	500	185	500	500	11.5	400	125 x 32

Swivel castors with wheel brakes and foot guards for your safety!

Crate dolly with ribbed rubber covering

Article no.	Dimension mm			Loading surface mm		Weight kg	Load cap. kg	Wheel diam. mm
	w	D	H	w	d			
sw-500.013	500	500	185	500	500	12.0	400	125 x 32

Swivel castors with wheel brakes and foot guards for your safety!



Crate dolly with diamond-tread load surface

Article no.	Dimension mm			Loading surface mm		Weight kg	Load cap. kg	Wheel diam. mm
	w	D	H	w	d			
sw-500.012	500	500	170	500	500	12.0	400	125 x 32

Swivel castors with wheel brakes and foot guards for your safety!



Customizing



VARIOfit[®]
Customizing comparison



Euro system dollies

Euro system dollies

Welded angle-steel construction; Versions with or without load surface of wood-based board, surface finish beech; Flush with frame or edge 10 mm high; For Euro size container 600 x 400 mm (W/D); Dollies powder-coated RAL 5010 gentian blue; Permanent surface protection; Impact- and scratch-resistant; Grey non-marking thermoplastic rubber tyres on plastic wheel rim with precision deepgroove ball bearings; Thread guard and foot guard; 4 swivel castors, 2 of them with brakes, or 4 swivel castors, 2 of them with **EasySTOP**.



Euro system dolly

Article no.	Dimension mm			Loading surface mm		Weight kg	Load cap. kg	Wheel diam. mm
	w	D	H	w	d			
sw-410.003	610	415	205	605	410	8.5	250	125 x 32

Swivel castors with wheel brakes and foot guards for your safety!



Euro system dolly with board (edge 10 mm)

Article no.	Dimension mm			Loading surface mm		Weight kg	Load cap. kg	Wheel diam. mm
	w	D	H	w	d			
sw-410.010	610	415	205	605	410	10.0	250	125 x 32

Swivel castors with wheel brakes and foot guards for your safety!

Euro system dolly with board

Article no.	Dimension mm			Loading surface mm		Weight kg	Load cap. kg	Wheel diam. mm
	w	D	H	w	d			
sw-410.009	610	415	205	610	415	10.0	250	125 x 32

Swivel castors with wheel brakes and foot guards for your safety!



Euro system dollies with EasySTOP



Euro system dolly

Article no.	Dimension			Loading surface		Weight	Load cap.	Wheel diam.
	W	D	H	w	d			
sw-410.063	610	415	235	605	410	9.5	250	125 x 32

EasySTOP swivel castors and foot guards for your safety!

Euro system dolly with board (edge 10 mm)

Article no.	Dimension			Loading surface		Weight	Load cap.	Wheel diam.
	W	D	H	w	d			
sw-410.070	610	415	235	605	410	11.0	250	125 x 32

EasySTOP swivel castors and foot guards for your safety!



Euro system dolly with board

Article no.	Dimension			Loading surface		Weight	Load cap.	Wheel diam.
	W	D	H	w	d			
sw-410.069	610	415	235	610	415	11.0	250	125 x 32

EasySTOP swivel castors and foot guards for your safety!

Euro system dollies

Euro system dollies

Welded angle-steel construction; Versions with or without load surface of wood-based board, surface finish beech; Flush with frame or edge 10 mm high; For Euro size container 600 x 400 mm (W/D); 4 sockets; Dollies powder-coated RAL 5010 gentian blue; Permanent surface protection; Impact- and scratch-resistant; Grey non-marking thermoplastic rubber tyres on plastic wheel rim with precision deepgroove ball bearings; Thread guard and foot guard; 4 swivel castors, 2 of them with **EasySTOP**.



Euro system dolly with sockets

Article no.	Dimension mm			Loading surface mm		Weight kg	Load cap. kg	Wheel diam. mm
	w	D	H	w	d			
sw-410.000	675	415	205	605	410	9.0	250	125 x 32

Swivel castors with wheel brakes and foot guards for your safety!



Euro system dolly with board (edge 10 mm) and sockets

Article no.	Dimension mm			Loading surface mm		Weight kg	Load cap. kg	Wheel diam. mm
	w	D	H	w	d			
sw-410.001	675	415	205	605	410	10.0	250	125 x 32

Swivel castors with wheel brakes and foot guards for your safety!



Euro system dolly with board and sockets

Article no.	Dimension mm			Loading surface mm		Weight kg	Load cap. kg	Wheel diam. mm
	w	D	H	w	d			
sw-410.002	675	415	205	610	415	10.5	250	125 x 32

Swivel castors with wheel brakes and foot guards for your safety!

Euro system dollies with EasySTOP



Euro system dolly with sockets

Article no.	Dimension			Loading surface		Weight	Load cap.	Wheel diam.
	w	D	H	w	d			
sw-410.060	675	415	235	605	410	10.0	250	125 x 32

EasySTOP swivel castors and foot guards for your safety!



Euro system dolly with board (edge 10 mm) and sockets

Article no.	Dimension			Loading surface		Weight	Load cap.	Wheel diam.
	w	D	H	w	d			
sw-410.061	675	415	235	605	410	11.5	250	125 x 32

EasySTOP swivel castors and foot guards for your safety!



Euro system dolly with board and sockets

Article no.	Dimension			Loading surface		Weight	Load cap.	Wheel diam.
	w	D	H	w	d			
sw-410.062	675	415	235	610	415	11.5	250	125 x 32

EasySTOP swivel castors and foot guards for your safety!

Euro system dollies



Euro system dollies

Welded angle-steel construction; Load surface of wood-based board, surface finish beech; Flush with frame or edge 10 mm high; For Euro size container 600 x 400 mm (W/D); 4 sockets; Versions with push bar or second load surface; Dollies powder-coated RAL 5010 gentian blue; Permanent surface protection; Impact- and scratch-resistant; Grey non-marking thermoplastic rubber tyres on plastic wheel rim with precision deepgroove ball bearings; Thread guard and foot guard; 4 swivel castors, 2 of them with brakes, or 4 swivel castors, 2 of them with **EasySTOP**.



Euro system dolly with board (edge 10 mm) and push bar

Article no.	Dimension			Loading surface		Weight kg	Load cap. kg	Wheel diam. mm
	W	D	H	w	d			
sw-410.011	740	415	970	605	410	13.5	250	125 x 32

Swivel castors with wheel brakes and foot guards for your safety!



Euro system dolly with board and push bar

Article no.	Dimension			Loading surface		Weight kg	Load cap. kg	Wheel diam. mm
	W	D	H	w	d			
sw-410.039	740	415	970	610	415	14.0	250	125 x 32

Swivel castors with wheel brakes and foot guards for your safety!

Also available in ESD design on page 104

Euro system dolly with 2 load surfaces (edge 10 mm)

Article no.	Dimension			Loading surface		Weight kg	Load cap. kg	Wheel diam. mm
	W	D	H	w	d			
sw-410.500	675	415	635	605	410	19.0	250	125 x 32

Load capacity shelf: 80 kg*
Swivel castors with wheel brakes and foot guards for your safety!



Also available in ESD design on page 104

Euro system dolly with 2 load surfaces

Article no.	Dimension			Loading surface		Weight kg	Load cap. kg	Wheel diam. mm
	W	D	H	w	d			
sw-410.501	675	415	635	610	415	19.0	250	125 x 32

Load capacity shelf: 80 kg*
Swivel castors with wheel brakes and foot guards for your safety!



*Static distributed load; Total load of the transport device must not be exceeded!

Euro system dollies with EasySTOP



Euro system dolly with board (edge 10 mm) and push bar

Article no.	Dimension			Loading surface		Weight	Load cap.	Wheel diam.
	W	D	H	w	d			
sw-410.071	740	415	1000	605	410	14.5	250	125 x 32

EasySTOP swivel castors and foot guards for your safety!

Euro system dolly with board and push bar

Article no.	Dimension			Loading surface		Weight	Load cap.	Wheel diam.
	W	D	H	w	d			
sw-410.079	740	415	1000	610	415	14.5	250	125 x 32

EasySTOP swivel castors and foot guards for your safety!



Also available in ESD design on page 104

Euro system dolly with 2 load surfaces (edge 10 mm)

Article no.	Dimension			Loading surface		Weight	Load cap.	Wheel diam.
	W	D	H	w	d			
sw-410.540	675	415	665	605	410	20.0	250	125 x 32

Load capacity shelf: 80 kg*
EasySTOP swivel castors and foot guards for your safety!



Also available in ESD design on page 104

Euro system dolly with 2 load surfaces

Article no.	Dimension			Loading surface		Weight	Load cap.	Wheel diam.
	W	D	H	w	d			
sw-410.541	675	415	665	610	415	20.0	250	125 x 32

Load capacity shelf: 80 kg*
EasySTOP swivel castors and foot guards for your safety!

*Static distributed load; Total load of the transport device must not be exceeded!

Push-handle dollies



Push-handle dollies

Welded steel construction; Open load surface or tubular steel load surface or load surface of wood based-board, surface finish beech; Open load surface suitable for plastic crates 600 x 400 mm (W/D); Screw-on handles; Dollies powder-coated RAL 5010 gentian blue; Permanent surface protection; Impact- and scratch-resistant; Grey non-marking thermoplastic rubber tyres on plastic wheel rim with precision deepgroove ball bearings; Thread guard and foot guard; 1 or 2 swivel castors with brakes and 2 fixed castors; Push-handle dolly with 2 load surfaces with 2 **EasySTOP** swivel castors and 2 fixed castors.



Push-handle dolly

Article no.	Dimension mm			Loading surface mm		Weight kg	Load cap. kg	Wheel diam. mm
	W	D	H	w	d			
sw-450.807	890	420	875	615	415	11.0	250	125 x 32

Swivel castors with wheel brakes and foot guards for your safety!



Push-handle dolly with plastic crate

Article no.	Dimension mm			Loading surface mm		Weight kg	Load cap. kg	Wheel diam. mm
	W	D	H	w	d			
sw-450.806	890	420	875	615	415	13.0	250	125 x 32

Swivel castors with wheel brakes and foot guards for your safety!

Push-handle dolly with tubular steel load surface

Article no.	Dimension mm			Loading surface mm		Weight kg	Load cap. kg	Wheel diam. mm
	W	D	H	w	d			
sw-450.805	785	450	875	565	450	8.5	150	125 x 32

Swivel castor with wheel brake and foot guard for your safety!



Push-handle dolly with tubular steel load surface

Article no.	Dimension mm			Loading surface mm		Weight kg	Load cap. kg	Wheel diam. mm
	W	D	H	w	d			
sw-500.801	880	500	880	605	500	9.5	250	125 x 32

Swivel castors with wheel brakes and foot guards for your safety!





Push-handle dolly with board

Article no.	Dimension			Loading surface		Weight	Load cap.	Wheel diam.
	W	D	H	w	d			
sw-450.804	785	450	875	565	450	9.5	150	125 x 32

Swivel castor with wheel brake and foot guard for your safety!

Push-handle dolly with board

Article no.	Dimension			Loading surface		Weight	Load cap.	Wheel diam.
	W	D	H	w	d			
sw-500.800	880	500	880	605	500	11.0	250	125 x 32

Swivel castors with wheel brakes and foot guards for your safety!



Also available in ESD design on page 105

Push-handle dolly with 2 load surfaces

Article no.	Dimension			Loading surface		Weight	Load cap.	Wheel diam.
	W	D	H	w	d			
sw-450.800	940	455	910	610	455	16.0	200	125 x 32

Load capacity shelf: 80 kg*
EasySTOP swivel castors and foot guards for your safety!

*Static distributed load; Total load of the transport device must not be exceeded!



VARIOfit

Quick-lift jack and two-wheeled platforms



Quick-lift jack

With ball head; Ball without safety catch; 2 plastic handles; Quick-lift jack powder-coated RAL 5010 gentian blue; Permanent surface protection; Impact- and scratch-resistant; Suitable for two-wheeled platforms with a load capacity of 500 kg; Grey non-marking thermoplastic rubber tyres on plastic wheel rim with precision deepgroove ball bearings, Ø 200 mm.

Quick-lift jack

Article no.	TR	Dimension mm			Weight kg	Load cap. kg	Wheel diam. mm
		w	D	H			
zu-1100	TR	400	270	1205	7.0	500	200 x 40

TR = Thermoplastic rubber tyres

Two-wheeled platforms

Welded steel construction; With 2 support runners; Ball head without safety catch; Platform and optional walls of wood-based board, surface finish beech; Walls permanently screwed; Usable height: 315 mm; Walled version has stacking corners with locating cups; Stacking height: 590 mm; Stackable four high when unloaded; Platforms powder-coated RAL 5010 gentian blue; Permanent surface protection; Impact- and scratch-resistant; Grey non-marking thermoplastic rubber tyres on plastic wheel rim with precision deepgroove ball bearings; Thread guard; 2 fixed castors.



Two-wheeled platform

Article no.	Dimension mm			Loading surface mm		Weight kg	Load cap. kg	Wheel diam. mm
	w	D	H	w	d			
zu-1109	905	495	285	895	495	28.5	500	200 x 40
zu-1110	1005	695	285	995	695	36.0	500	200 x 40
zu-1112	1205	795	285	1195	795	41.5	500	200 x 40
zu-1116	1605	895	285	1595	895	49.5	500	200 x 40



Two-wheeled platform with end walls

Article no.	Dimension mm			Loading surface mm		Weight kg	Load cap. kg	Wheel diam. mm
	w	D	H	w	d			
zu-1120	1090	780	660	1000	700	43.0	500	200 x 40
zu-1121	1290	880	660	1200	800	46.0	500	200 x 40



Two-wheeled platform with 4 walls

Article no.	Dimension mm			Loading surface mm		Weight kg	Load cap. kg	Wheel diam. mm
	w	D	H	w	d			
zu-1122	1090	780	660	975	675	52.5	500	200 x 40
zu-1123	1290	880	660	1175	775	55.0	500	200 x 40

Safety quick-lift jack

Steel construction with ball head of diameter 47 mm; With locking system; Reliable engagement with two-wheeled platform; Safety quick-lift jack painted RAL 2002 vermillion; Suitable for two-wheeled platforms with a load capacity of 1,000 - 3,000 kg; Elastic solid-rubber tyres with ball bearings.

Safety quick-lift jack

Article no.	Dimension			for two-wheeled platforms with load cap. kg	Weight kg	Wheel diam. mm	
	w	mm D	H				
zsw-1000	ER	385	270	1275	1000	18.0	180 x 50
zsw-1500	ER	390	305	1305	1500	22.0	250 x 80
zsw-2000	ER	440	305	1305	2000	25.0	250 x 80
zsw-3000	ER	440	305	1305	3000	25.0	250 x 80

ER = Elastic solid-rubber tyres



Two-wheeled platforms

Welded steel construction; 2 support runners; Socket with safety catch; Load surface of waterproof bonded plywood, surface finish screen printed, anti-slip; Platforms powder-coated RAL 5010 gentian blue; Permanent surface protection; Impact- and scratch-resistant; Elastic solid-rubber tyres or polyurethane tyres on cast aluminium wheel rim with precision deepgroove ball bearings; Mounted on a single axle.

Two-wheeled platform

Article no.		Dimension			Loading surface		Weight kg	Load cap. kg	Wheel diam. mm
		w	mm D	H	w	mm d			
zu-1130	ER	1005	700	315	990	700	46.5	1000	200 x 50
zu-1131	ER	1205	800	315	1190	800	57.0	1000	200 x 50
zu-1132	ER	1605	900	315	1590	900	62.5	1000	200 x 50
zu-1133	ER	2005	1000	315	1990	1000	69.5	1000	200 x 50

ER = Elastic solid-rubber tyres



Two-wheeled platform

Article no.		Dimension			Loading surface		Weight kg	Load cap. kg	Wheel diam. mm
		w	mm D	H	w	mm d			
zu-1134	ER	1005	700	340	990	700	51.0	1500	250 x 50
zu-1135	ER	1205	800	340	1190	800	54.5	1500	250 x 50
zu-1136	ER	1605	900	340	1590	900	68.0	1500	250 x 50
zu-1137	ER	2005	1000	340	1990	1000	86.0	1500	250 x 50
zu-1138	ER	2505	800	340	2490	800	91.5	1500	250 x 50
zu-1141	PO	1205	800	340	1190	800	57.0	2000	250 x 50
zu-1142	PO	1605	900	340	1590	900	71.0	2000	250 x 50
zu-1143	PO	2005	1000	340	1990	1000	88.5	2000	250 x 50
zu-1144	PO	2505	800	340	2490	800	94.5	2000	250 x 50
zu-1147	PO	1205	800	340	1190	800	54.5	3000	250 x 50
zu-1148	PO	1605	900	340	1590	900	72.5	3000	250 x 50
zu-1149	PO	2005	1000	340	1990	1000	90.5	3000	250 x 50
zu-1150	PO	2505	800	340	2490	800	96.0	3000	250 x 50

ER = Elastic solid-rubber tyres, PO = Polyurethane tyres



Two-wheeled platform

Article no.		Dimension			Loading surface		Weight kg	Load cap. kg	Wheel diam. mm
		w	mm D	H	w	mm d			
zu-1139	ER	3305	800	390	3290	800	97.0	1500	250 x 50
zu-1140	ER	4005	800	390	3990	800	187.5	1500	250 x 50
zu-1145	PO	3305	800	390	3290	800	161.5	2000	250 x 50
zu-1146	PO	4005	800	390	3990	800	194.0	2000	250 x 50
zu-1151	PO	3305	800	390	3290	800	161.5	3000	250 x 50
zu-1152	PO	4005	800	390	3990	800	194.0	3000	250 x 50

ER = Elastic solid-rubber tyres, PO = Polyurethane tyres

Tubular-steel trucks



Tubular steel trucks

Welded steel construction; With 2 innovative plastic safety handles; Toe of sheet steel; Either with bended transverse struts or with verticle struts; Trucks powder-coated RAL 5010 gentian blue; Permanent surface protection; Impact- and scratch-resistant; Pneumatic tyres on steel wheel rim or solid-rubber tyres on special plastic wheel rim with precision deepgroove ball bearings and plastic wheel cap; Tubular steel truck with additional support roller with grey non-marking thermoplastic rubber tyres on plastic wheel rim with precision deepgroove ball bearings; Thread guard; 2 swivel castors; With gas pressure spring and 1 non-slip pedal on axle.



Tubular steel truck

Article no.		Dimension			Toe plate		Weight kg	Load cap. kg	Wheel diam. mm
		W	mm D	H	w mm	d			
sk-710.015	P	570	530	1105	320	250	12.5	200	260 x 85
sk-710.016	SR	570	530	1105	320	250	14.5	200	260 x 65

P = Pneumatic tyres, SR = Solid-rubber tyres



Tubular steel truck

Article no.		Dimension			Toe plate		Weight kg	Load cap. kg	Wheel diam. mm
		W	mm D	H	w mm	d			
sk-710.010	P	570	585	1310	320	250	17.0	250	260 x 85
sk-710.011	SR	570	585	1310	320	250	19.0	250	260 x 65

P = Pneumatic tyres, SR = Solid-rubber tyres



Tubular steel truck with 2 additional support roller

Article no.		Dimension			Toe plate		Weight kg	Load cap. kg	Wheel diam. mm
		W	mm D	H	w mm	d			
sk-710.055	P	575	585	1305	320	250	21.5	250	260 x 85
sk-710.065	SR	575	585	1305	320	250	25.5	250	260 x 65

P = Pneumatic tyres, SR = Solid-rubber tyres





Tubular steel truck

Article no.		Dimension			Toe plate		Weight kg	Load cap. kg	Wheel diam. mm
		W	mm D	H	w	d			
sk-710.020	P	620	460	1110	400	150	13.5	250	260 x 85
sk-710.021	SR	620	460	1110	400	150	15.5	250	260 x 65

P = Pneumatic tyres, SR = Solid-rubber tyres

Tubular steel truck with large toe plate

Article no.		Dimension			Toe plate		Weight kg	Load cap. kg	Wheel diam. mm
		W	mm D	H	w	d			
sk-710.213	P	570	585	1310	480	300	21.0	250	260 x 85
sk-710.214	SR	570	585	1310	480	300	23.0	250	260 x 65

P = Pneumatic tyres, SR = Solid-rubber tyres



Tubular steel truck

Article no.		Dimension			Toe plate		Weight kg	Load cap. kg	Wheel diam. mm
		W	mm D	H	w	d			
sk-710.030	P	550	740	1600	300	260	20.0	250	260 x 85
sk-710.031	SR	550	740	1600	300	260	22.0	250	260 x 65

P = Pneumatic tyres, SR = Solid-rubber tyres

Tubular steel trucks

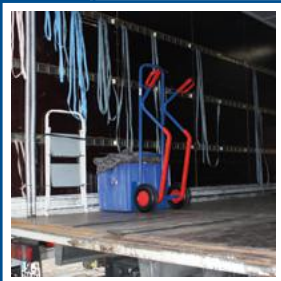

Tubular steel trucks

Welded steel construction; With 2 innovative plastic safety handles; Toe of sheet steel; Partial with bended transverse strut; Plastic skids are replaceable and mounted completely on the tube; Trucks powder-coated RAL 5010 gentian blue; Permanent surface protection; Impact- and scratch-resistant; Pneumatic tyres on steel wheel rim or solid-rubber tyres on special plastic wheel rim with precision deepgroove ball bearings and plastic wheel cap; Optional with puncture-proof tyres.



Tubular steel truck

Article no.		Dimension mm			Toe plate mm		Weight kg	Load cap. kg	Wheel diam. mm
		W	D	H	w	d			
sk-710.005	P	550	615	1305	320	250	18.0	250	260 x 85
sk-710.006	SR	550	615	1305	320	250	19.5	250	260 x 65

P = Pneumatic tyres, SR = Solid-rubber tyres

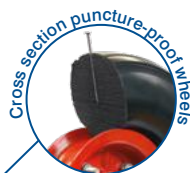

Tubular steel truck with puncture-proof tyres

Article no.		Dimension mm			Toe plate mm		Weight kg	Load cap. kg	Wheel diam. mm
		W	D	H	w	d			
sk-710.014		550	615	1305	320	250	18.5	250	260 x 85

Tubular steel truck with large toe plate

Article no.		Dimension mm			Toe plate mm		Weight kg	Load cap. kg	Wheel diam. mm
		W	D	H	w	d			
sk-710.201	P	570	655	1315	480	300	20.0	250	260 x 85
sk-710.202	SR	570	655	1315	480	300	22.0	250	260 x 65

P = Pneumatic tyres, SR = Solid-rubber tyres



Tubular steel trucks

Welded steel construction; With 2 innovative plastic safety handles; Toe of sheet steel; Optional foldable; Partial with bended transverse strut; Plastic skids are replaceable and mounted completely on the tube; Trucks powder-coated RAL 5010 gentian blue; Permanent surface protection; Impact- and scratch-resistant; Pneumatic tyres on steel wheel rim or solid-rubber tyres on special plastic wheel rim with precision deepgroove ball bearings and plastic wheel cap.



Tubular steel truck with folding toe plate

Article no.		Dimension mm			Toe plate mm		Weight kg	Load cap. kg	Wheel diam. mm
		W	D	H	w	d			
sk-710.217	P	570	610	1300	320	255	21.0	200	260 x 85
sk-710.218	SR	570	610	1300	320	255	23.0	200	260 x 65

P = Pneumatic tyres, SR = Solid-rubber tyres

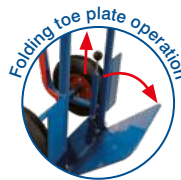

Tubular steel truck with folding toe plate

Article no.		Dimension mm			Toe plate mm		Weight kg	Load cap. kg	Wheel diam. mm
		W	D	H	w	d			
sk-710.215	P	570	545	1300	320	255	18.5	250	260 x 85
sk-710.216	SR	570	545	1300	320	255	20.0	250	260 x 65

P = Pneumatic tyres, SR = Solid-rubber tyres



Tubular steel truck with large toe plate

Article no.		Dimension mm			Toe plate mm		Weight kg	Load cap. kg	Wheel diam. mm
		W	D	H	w	d			
sk-710.203	P	570	650	1305	480	300	19.5	250	260 x 85
sk-710.204	SR	570	650	1305	480	300	21.0	250	260 x 65

P = Pneumatic tyres, SR = Solid-rubber tyres

Tubular steel trucks



Tubular steel trucks

Welded steel construction; With 2 innovative plastic safety handles; Toe of sheet steel; Bended transverse struts and verticle struts; Optionally available with 2 stands for parking the truck; Trucks powder-coated RAL 5010 gentian blue; Permanent surface protection; Impact- and scratch-resistant; Pneumatic tyres on steel wheel rim or solid-rubber tyres on special plastic wheel rim with precision deepgroove ball bearings and plastic wheel cap.

Tubular steel truck with large toe plate

Article no.		Dimension mm			Toe plate mm		Weight kg	Load cap. kg	Wheel diam. mm
		W	D	H	w	d			
sk-710.205	P	690	600	1110	480	300	18.0	250	260 x 85
sk-710.206	SR	690	600	1110	480	300	20.0	250	260 x 65

P = Pneumatic tyres, SR = Solid-rubber tyres



Additional carrying bars for all trucks on pages 52 - 55, 166 - 180 and 182 you find on page 182

Tubular steel truck with large toe plate

Article no.		Dimension mm			Toe plate mm		Weight kg	Load cap. kg	Wheel diam. mm
		W	D	H	w	d			
sk-710.207	P	690	710	1200	480	300	22.5	250	260 x 85
sk-710.208	SR	690	710	1200	480	300	24.0	250	260 x 65

P = Pneumatic tyres, SR = Solid-rubber tyres

Tubular steel truck with large toe plate

Article no.		Dimension mm			Toe plate mm		Weight kg	Load cap. kg	Wheel diam. mm
		W	D	H	w	d			
sk-710.117	P	690	550	1200	480	140	20.0	250	260 x 85
sk-710.118	SR	690	550	1200	480	140	21.5	250	260 x 65

P = Pneumatic tyres, SR = Solid-rubber tyres





Tubular steel truck

Article no.		Dimension			Toe plate		Weight kg	Load cap. kg	Wheel diam. mm
		W	mm D	H	w mm	d			
sk-1151	P	550	430	1100	400	110	14.5	200	260 x 85
sk-1150	SR	550	430	1100	400	110	16.5	200	260 x 65

P = Pneumatic tyres, SR = Solid-rubber tyres

Tubular steel truck

Article no.		Dimension			Toe plate		Weight kg	Load cap. kg	Wheel diam. mm
		W	mm D	H	w mm	d			
sk-1153	P	620	440	1110	450	120	15.5	250	260 x 85
sk-1152	SR	620	440	1110	450	120	17.0	250	260 x 65

P = Pneumatic tyres, SR = Solid-rubber tyres



Tubular steel truck

Article no.		Dimension			Toe plate		Weight kg	Load cap. kg	Wheel diam. mm
		W	mm D	H	w mm	d			
sk-1155	P	620	470	1110	450	120	16.5	250	260 x 85
sk-1154	SR	620	470	1110	450	120	18.0	250	260 x 65

P = Pneumatic tyres, SR = Solid-rubber tyres

Tubular steel trucks

Tubular steel trucks

Welded steel construction; With 2 innovative plastic safety handles; Toe of sheet steel; Bended transverse struts and verticle struts; With 2 stands for parking the truck; Trucks powder-coated RAL 5010 gentian blue; Permanent surface protection; Impact- and scratch-resistant; Pneumatic tyres on steel wheel rim or solid-rubber tyres on special plastic wheel rim with precision deepgroove ball bearings and plastic wheel cap.



Tubular steel truck

Article no.		Dimension			Toe plate		Weight kg	Load cap. kg	Wheel diam. mm
		W	D	H	w	d			
sk-1251	P	620	500	1220	450	150	19.5	250	260 x 85
sk-1250	SR	620	500	1220	450	150	21.0	250	260 x 65

P = Pneumatic tyres, SR = Solid-rubber tyres

Our quality characteristics

Plastic safety handle

Using improved materials; Their flexibility reduces the risk of breakage and ensures optimum user safety.

Precision deepgroove ball bearings

Sealed, maintenance-free precision deepgroove ball bearings. Guaranteed easy running when loaded, even on sloping or rough surfaces.

Wheel mounting

The **VARIOfit**® truck wheels (pneumatic, solid-rubber and puncture-proof tyres) are secured with a lock nut which is screwed onto the axle. This prevents the wheels from working loose during use.

Plastic skirts

Specially developed by **VARIOfit**®, provide optimum safety. They continue past the bend in the tube to ensure there is no chance of catching or jamming.

Puncture-proof tyres

Same good running characteristics as pneumatic tyres; Filled with foamed ethylene vinyl acetate; Absorbs shocks, absorbs vibrations and is very directionally stable; Resistant to nails, curbs or other physical impacts; Optimum tires for heavy loads and daily use; On steel wheel rim with precision deepgroove ball bearing and plastic hub cap.

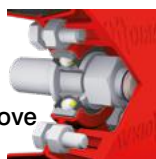
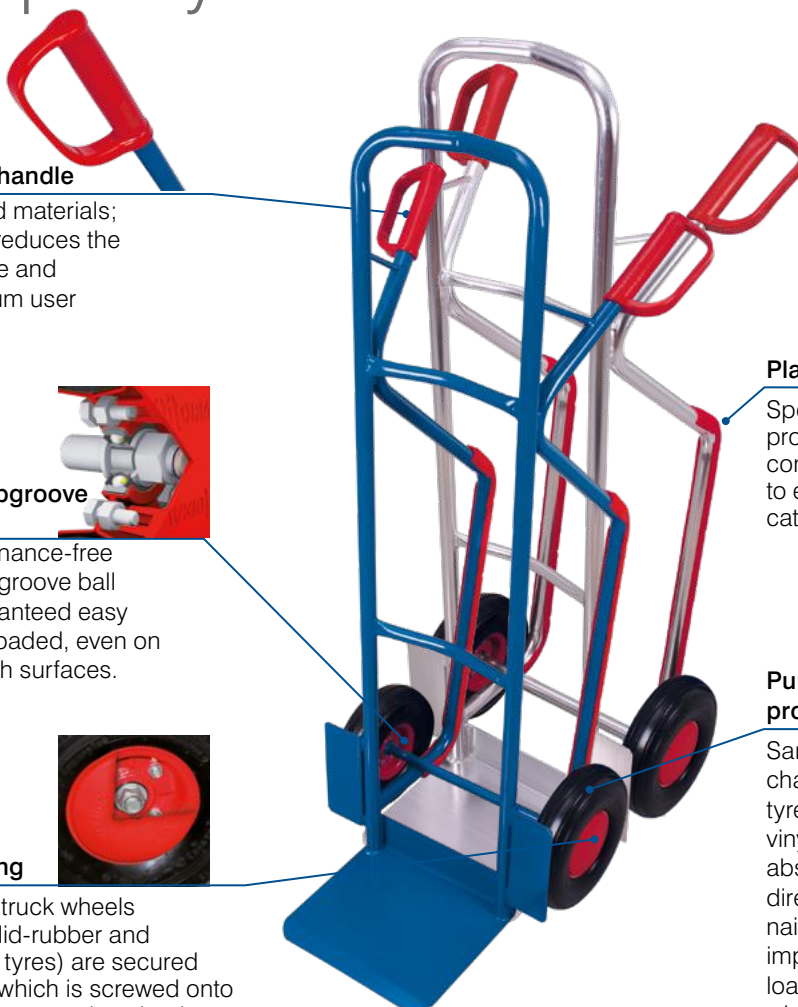

Aluminium trucks



Aluminium trucks

Welded aluminium construction; Very light and handy; With 2 innovative plastic safety handles; Bended transverse struts; Plastic skirts are replaceable and mounted completely on the tube; Pneumatic tyres on steel wheel rim or solid-rubber tyres on special plastic wheel rim with precision deepgroove ball bearings and plastic wheel cap.

Aluminium truck

Article no.		Dimension			Toe plate		Weight	Load cap.	Wheel diam.
		W	D	H	w	d			
ap-710.015	P	570	530	1075	320	250	9.5	150	260 x 85
ap-710.016	SR	570	530	1075	320	250	11.0	150	260 x 65

P = Pneumatic tyres, SR = Solid-rubber tyres



Aluminium truck

Article no.		Dimension			Toe plate		Weight	Load cap.	Wheel diam.
		W	D	H	w	d			
ap-710.010	P	570	610	1305	320	250	11.0	200	260 x 85
ap-710.011	SR	570	610	1305	320	250	13.0	200	260 x 65

P = Pneumatic tyres, SR = Solid-rubber tyres



Aluminium truck

Article no.		Dimension			Toe plate		Weight	Load cap.	Wheel diam.
		W	D	H	w	d			
ap-710.005	P	570	615	1300	320	250	12.5	200	260 x 85
ap-710.006	SR	570	615	1300	320	250	13.5	200	260 x 65

P = Pneumatic tyres, SR = Solid-rubber tyres

Aluminium trucks

Aluminium trucks

Welded aluminium construction; Very light and handy; With 2 innovative plastic safety handles; Either with bended transverse struts or with vertical struts; Optional with folding toe plate; Plastic skids are replaceable and mounted completely on the tube; Pneumatic tyres on steel wheel rim or solid-rubber tyres on special plastic wheel rim with precision deepgroove ball bearings and plastic wheel cap; Optional with puncture-proof tyres.

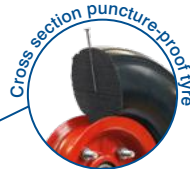

Aluminium truck with puncture-proof tyres

Article no.	Dimension mm			Toe plate mm		Weight kg	Load cap. kg	Wheel diam. mm
	w	D	H	w	d			
ap-710.214	570	615	1300	320	250	13.0	200	260 x 85



Aluminium truck with large toe plate

Article no.		Dimension mm			Toe plate mm		Weight kg	Load cap. kg	Wheel diam. mm
		w	D	H	w	d			
ap-710.107	P	605	660	1305	480	300	14.0	200	260 x 85
ap-710.204	SR	605	660	1305	480	300	15.0	200	260 x 65

P = Pneumatic tyres, SR = Solid-rubber tyres



Aluminium truck with folding toe plate

Article no.		Dimension mm			Toe plate mm		Weight kg	Load cap. kg	Wheel diam. mm
		w	D	H	w	d			
ap-710.211	P	550	640	1300	380	280	13.0	200	260 x 85
ap-710.212	SR	550	640	1300	380	280	16.0	200	260 x 65

P = Pneumatic tyres, SR = Solid-rubber tyres



Aluminium trucks with large toe



Aluminium truck with large toe plate

Article no.		Dimension mm			Toe plate mm		Weight kg	Load cap. kg	Wheel diam. mm
		w	D	H	w	d			
ap-710.103	P	570	635	1310	480	300	12.0	200	260 x 85
ap-710.202	SR	570	635	1310	480	300	13.5	200	260 x 65

P = Pneumatic tyres, SR = Solid-rubber tyres



Aluminium truck with large toe plate

Article no.		Dimension mm			Toe plate mm		Weight kg	Load cap. kg	Wheel diam. mm
		w	D	H	w	d			
ap-710.205	P	690	600	1110	480	300	11.5	200	260 x 85
ap-710.206	SR	690	600	1110	480	300	13.5	200	260 x 65

P = Pneumatic tyres, SR = Solid-rubber tyres

Solid-rubber tyres
with groove profile

Puncture-proof tyres
with groove profile

Pneumatic tyres with
groove profile



Stair-climber trucks

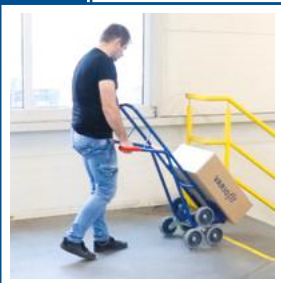

Stair-climber trucks

Welded steel construction; With 2 innovative plastic safety handles; Toe of sheet steel; Partial with bended transverse struts; Trucks powder-coated RAL 5010 gentian blue; Permanent surface protection; Impact- and scratch-resistant; Available with 2 three-arm or five-arm star wheels; Screwed; Three- or five-arm star wheels of grey non-marking thermoplastic rubber tyres on plastic wheel rim with precision deepgroove ball bearings; Thread guard; Pneumatic tyres on steel wheel rim or solid-rubber tyres on special plastic wheel rim with precision deepgroove ball bearings and plastic wheel cap.



Stair-climber truck with 2 three-arm star wheels

Article no.		Dimension			Toe plate		Weight	Load cap.	Wheel diam.
		W	D	H	w	d			
sk-1300	TR	610	630	1310	300	255	23.5	200	160 x 40

TR = Thermoplastic rubber tyres



Stair-climber truck with 2 three-arm star wheels

Article no.		Dimension			Toe plate		Weight	Load cap.	Wheel diam.
		W	D	H	w	d			
sk-710.212	TR	620	625	1310	320	245	22.0	200	160 x 40

TR = Thermoplastic rubber tyres



Stair-climber truck with 2 three-arm star wheels

Article no.		Dimension			Toe plate		Weight	Load cap.	Wheel diam.
		W	D	H	w	d			
sk-710.210	TR	620	675	1310	480	295	24.0	200	160 x 40

TR = Thermoplastic rubber tyres



Stair-climber truck with 2 five-arm star wheels

Article no.		Dimension			Toe plate		Weight	Load cap.	Wheel diam.
		w	D	H	w	d			
sk-1301	P	610	705	1310	300	285	25.5	200	260 x 85
sk-1303	SR	610	705	1310	300	285	27.5	200	260 x 65

P = Pneumatic tyres, SR = Solid-rubber tyres

Stair-climber truck with 2 five-arm star wheels

Article no.		Dimension			Toe plate		Weight	Load cap.	Wheel diam.
		w	D	H	w	d			
sk-710.211	P	610	675	1310	300	250	24.5	200	260 x 85
sk-710.222	SR	610	675	1310	300	250	26.5	200	260 x 65

P = Pneumatic tyres, SR = Solid-rubber tyres



Stair-climber truck with 2 five-arm star wheels

Article no.		Dimension			Toe plate		Weight	Load cap.	Wheel diam.
		w	D	H	w	d			
sk-710.209	P	610	725	1310	480	300	27.5	200	260 x 85
sk-710.236	SR	610	725	1310	480	300	29.5	200	260 x 65

P = Pneumatic tyres, SR = Solid-rubber tyres

Aluminium stair-climber trucks



Aluminium stair-climber trucks

Welded aluminium construction; With 2 innovative plastic safety handles; Partial with bended transverse struts; Available with 2 three-arm or five-arm star wheels; Screwed; Three- or five-arm star wheels of grey non-marking thermoplastic rubber tyres on plastic wheel rim with precision deepgroove ball bearings; Thread guard; Pneumatic tyres on steel wheel rim or solid-rubber tyres on special plastic wheel rim with precision deepgroove ball bearings and plastic wheel cap.



Aluminium stair-climber truck with 2 three-arm star wheels

Article no.	Dimension			Toe plate		Weight kg	Load cap. kg	Wheel diam. mm	
	w	D	H	w	d				
ap-1300	TR	610	630	1310	300	255	16.0	200	160 x 40

TR = Thermoplastic rubber tyres



Aluminium stair-climber truck with 2 three-arm star wheels

Article no.	Dimension			Toe plate		Weight kg	Load cap. kg	Wheel diam. mm	
	w	D	H	w	d				
ap-710.208	TR	620	625	1310	320	245	15.0	200	160 x 40

TR = Thermoplastic rubber tyres



Aluminium stair-climber truck with 2 three-arm star wheels

Article no.	Dimension			Toe plate		Weight kg	Load cap. kg	Wheel diam. mm	
	w	D	H	w	d				
ap-710.210	TR	620	675	1310	480	295	16.0	200	160 x 40

TR = Thermoplastic rubber tyres



Aluminium stair-climber truck with 2 five-arm star wheels

Article no.		Dimension			Toe plate		Weight	Load cap.	Wheel diam.
		w	D	H	w	d			
ap-1301	P	610	705	1310	300	285	18.5	200	260 x 85
ap-1302	SR	610	705	1310	300	285	20.5	200	260 x 65

P = Pneumatic tyres, SR = Solid-rubber tyres



Aluminium stair-climber truck with 2 five-arm star wheels

Article no.		Dimension			Toe plate		Weight	Load cap.	Wheel diam.
		w	D	H	w	d			
ap-710.207	P	610	675	1310	300	250	18.0	200	260 x 85
ap-710.228	SR	610	675	1310	300	250	20.0	200	260 x 65

P = Pneumatic tyres, SR = Solid-rubber tyres



Aluminium stair-climber truck with 2 five-arm star wheels

Article no.		Dimension			Toe plate		Weight	Load cap.	Wheel diam.
		w	D	H	w	d			
ap-710.209	P	610	725	1310	480	300	19.5	200	260 x 85
ap-710.298	SR	610	725	1310	480	300	21.5	200	260 x 65

P = Pneumatic tyres, SR = Solid-rubber tyres

Chair and furniture trucks



Chair and furniture trucks

Welded steel or aluminium construction; With 2 innovative plastic safety handles; Bended transverse struts; Chair support with antislip covering; Removable; With continuous height adjustment; Length: 505 mm; Furniture trucks with transparent soft tube cover; Toe with antislip covering; Steel trucks powder-coated RAL 5010 gentian blue; Permanent surface protection; Impact- and scratch-resistant; Pneumatic tyres on steel wheel rim or solid-rubber tyres on special plastic wheel rim with precision deepgroove ball bearings and plastic wheel cap.

Chair truck

Article no.		Dimension			Toe plate		Weight kg	Load cap. kg	Wheel diam. mm
		W	D	H	w	d			
sk-710.028	P	570	795	1305	320	250	20.0	250	260 x 85
sk-710.029	SR	570	795	1305	320	250	22.0	250	260 x 65

P = Pneumatic tyres, SR = Solid-rubber tyres



Aluminium chair truck

Article no.		Dimension			Toe plate		Weight kg	Load cap. kg	Wheel diam. mm
		W	D	H	w	d			
ap-710.058	P	570	795	1305	320	250	12.0	250	260 x 85
ap-710.059	SR	570	795	1305	320	250	13.5	250	260 x 65

P = Pneumatic tyres, SR = Solid-rubber tyres



Furniture truck

Article no.		Dimension			Toe plate		Weight kg	Load cap. kg	Wheel diam. mm
		W	D	H	w	d			
sk-710.230	P	620	635	1400	360	335	17.5	250	260 x 85
sk-710.231	SR	620	635	1400	360	335	19.5	250	260 x 65

P = Pneumatic tyres, SR = Solid-rubber tyres

Anti-slip cover:

The anti-slip cover prevents the loaded goods from slipping off the toe.



Soft tube cover:

The transparency soft tube cover protects the goods from minor damage.



Aluminium furniture truck

Article no.		Dimension			Toe plate		Weight kg	Load cap. kg	Wheel diam. mm
		W	D	H	w	d			
ap-710.200	P	640	625	1410	360	320	12.5	200	260 x 85
ap-710.201	SR	640	625	1410	360	320	14.5	200	260 x 65

P = Pneumatic tyres, SR = Solid-rubber tyres

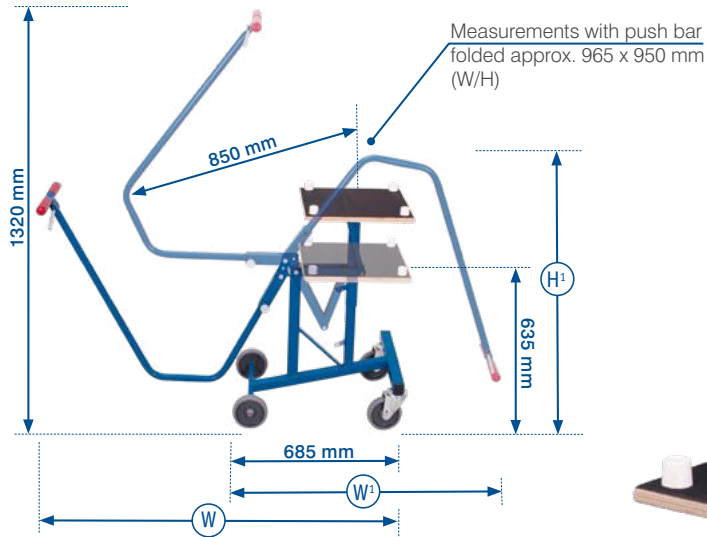

Table transporter



Table transporter

Welded steel construction; Push bar with 2 plastic handles; Reversible; Lockable; Including lever for locking the lifting movement; Support with ribbed rubber covering and 4 white rubber studs; For diagonal and length wise transport; Table-transporter powder-coated RAL 5010 gentian blue; Permanent surface protection; Impact- and scratch-resistant; Grey non-marking thermoplastic rubber tyres on plastic wheel rim with precision deepgroove ball bearings; Thread guard; 2 castors on one axle and 2 swivel castors.



Saves min. 50% work!

Table support with rubber pads; Guaranteed non-damaging engagement and non-slip transport



Lift is automatically locked in final position; The table is lowered by operation a release lever on the push bar

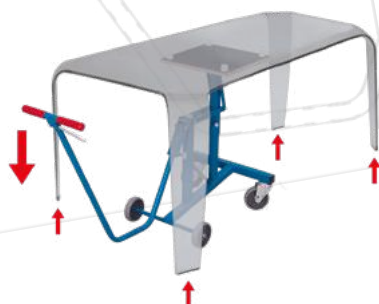
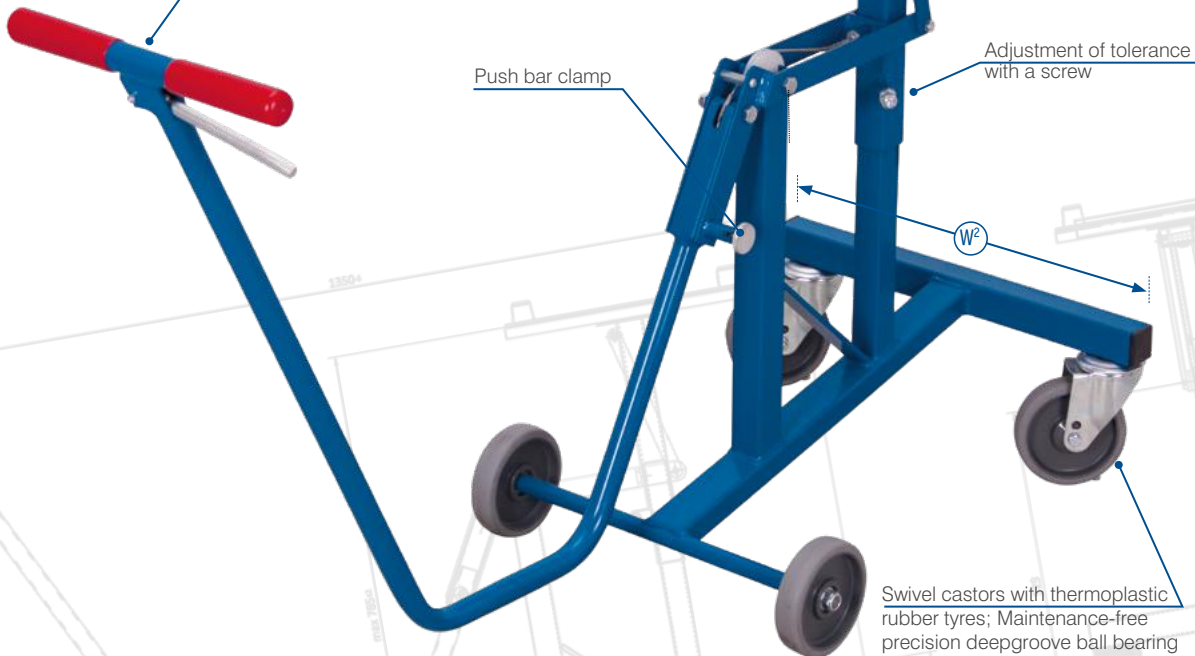

Table transporter

Article no.	Dimension			Loading surface		Weight kg	Load cap. kg	Wheel diam. mm
	W	D	H	w	d			
sw-490.001	1350	490	815	375	375	17.5	100	125 x 32
	w ¹	w ²	H ¹	Measurements with push bar folded				

Wheels with precision deepgroove ball bearings

Appliance trucks



Appliance trucks

Welded steel construction; With 2 innovative plastic safety handles; Toe of sheet steel; Partial with bended transverse strut; Optionally available with 2 stands for parking the truck; Optional toes and bars with hollow rubber profile; Trucks powder-coated RAL 5010 gentian blue; Permanent surface protection; Impact- and scratch-resistant; Appliance truck with 2 three-arm star wheels with star wheel clamp; Three-arm star wheels of grey non-marking thermoplastic rubber tyres on plastic wheel rim with precision deepgroove ball bearings; Thread guard; Pneumatic tyres on steel wheel rim or solid-rubber tyres on special plastic wheel rim with precision deepgroove ball bearings and plastic wheel cap.

Appliance truck

Article no.		Dimension			Toe plate		Weight kg	Load cap. kg	Wheel diam. mm
		W	mm D	H	w mm	d			
sk-1399	P	705	575	1455	450	120	25.0	250	260 x 85
sk-1400	SR	705	575	1455	450	120	27.0	250	260 x 65

P = Pneumatic tyres, SR = Solid-rubber tyres



Appliance truck with 2 three-arm star wheels

Article no.		Dimension			Toe plate		Weight kg	Load cap. kg	Wheel diam. mm
		W	mm D	H	w mm	d			
sk-1157	TR	640	525	1155	450	150	21.5	250	160 x 40

TR = Thermoplastic rubber tyres

Appliance truck

Article no.		Dimension			Toe plate		Weight kg	Load cap. kg	Wheel diam. mm
		W	mm D	H	w mm	d			
sk-1156	P	640	425	1145	450	150	17.5	250	260 x 85
sk-1163	SR	640	425	1145	450	150	19.5	250	260 x 65

P = Pneumatic tyres, SR = Solid-rubber tyres



Additional carrying bars for all trucks on pages 52-55, 166-180 and 182

Additional article - Carrying bar for stair climbing (1 pair)

Article no.	Length mm	Weight kg	
gsk-1156	855	3.0	Carrying bar

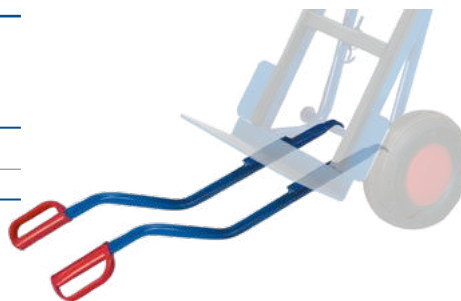

Heavy-duty truck with 2 additional support roller

NEW

Heavy-duty truck with 2 additional support roller

Stable welded tubular steel construction; Especially developed for the transport of bulky goods, e.g. vending machines and cabinets; Handles of round tube with soft black plastic cover; Contact surface with grey hollow rubber profile; Toe plate with vulcanized rubber; Incl. 4 eyes at heights 600 and 1,600 mm for fastening the goods using 2 integrated tension belts; With fold-out, height-adjustable supporting wheels; Supporting wheels of grey non-marking thermoplastic rubber tyres on plastic wheel rim with precision deepgroove ball bearings; Thread guard; 2 swivel castors with brakes; Supporting wheels element can be adjusted in 3 stages with just one handle; Heavy-duty truck powder-coated RAL 5010 gentian blue; Permanent surface protection; Impact- and scratch-resistant; Polyurethane tyres 92° Shore A on cast aluminium wheel rim with precision deepgroove ball bearings.



Heavy-duty truck with 2 additional support roller

Article no.	PO	Dimension mm			Toe plate mm		Weight kg	Load cap. kg	Wheel diam. mm
		w	D	H	w	d			
sk-710.083	PO	600	400	1700	600	150	35.0	550	250 x 50

PO = Polyurethane tyres

Dimensions

Pos. 1		Pos. 2		Pos. 3		Pos. 4	
D	H	D	H	D	H	D	H
400	1700	1410	1370	1575	1160	1685	920



Pos. 1



Pos. 2



Pos. 3



Pos. 4



Customizing

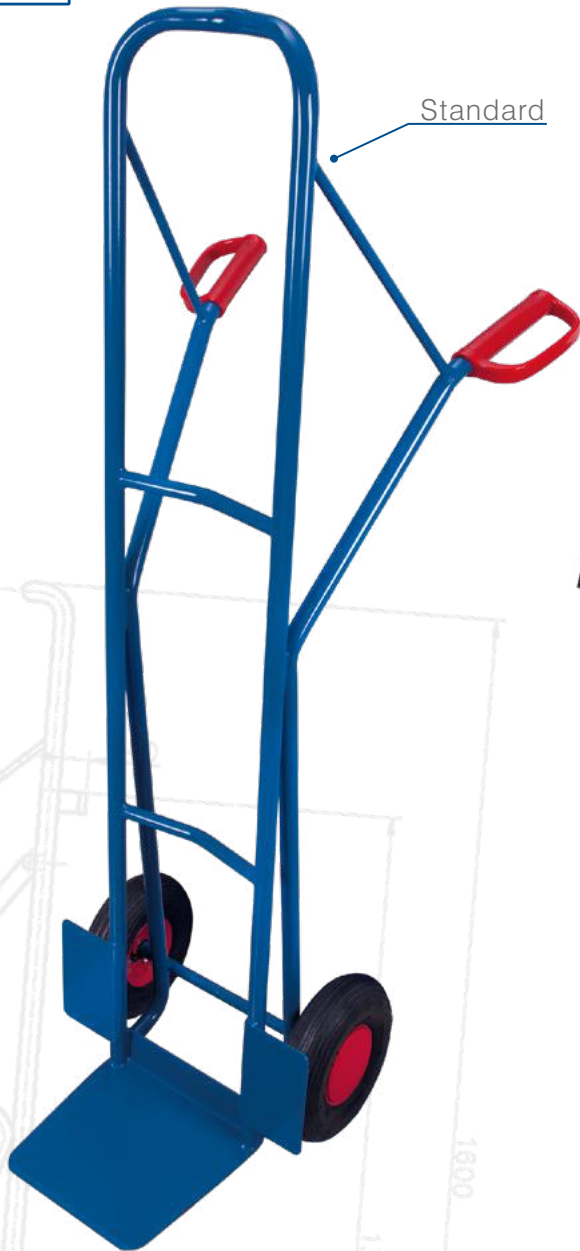

Standard



Customizing



VARIOfit[®]

Customizing comparison

Lightweight folding truck and parcel trucks



Lightweight folding truck

Welded steel construction; Double-fold for easy transport; Locking and unlocking by cable; Grip with soft plastic cover; Lightweight folding truck powder-coated RAL 5010 gentian blue; Permanent surface protection; Impact- and scratch-resistant; Pneumatic tyres on steel wheel rim with precision deepgroove ball bearings and plastic wheel cap.



Folded W=420 x D=322 x H=465 mm

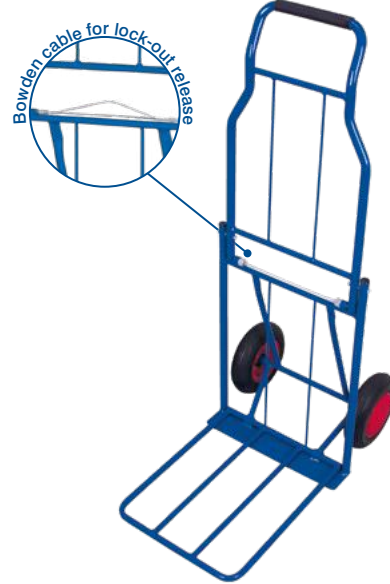

Lightweight folding truck

Article no.	Dimension mm			Toe plate mm		Weight kg	Load cap. kg	Wheel diam. mm	
	w	D	H	w	d				
sk-710.420	P	430	715	1165	375	450	9.5	80	230 x 55

P = Pneumatic tyres

Parcel trucks

Welded steel construction; Either only toe plate foldable or double-fold version for easy transport; Parcel trucks powder-coated RAL 5010 gentian blue; Permanent surface protection; Impact- and scratch-resistant; Pneumatic tyres on steel wheel rim, black, or thermoplastic rubber tyres on plastic wheel rim with precision deepgroove ball bearings, grey, non-marking; Thread guard.



Parcel truck

Article no.		Dimension mm			Toe plate mm		Weight kg	Load cap. kg	Wheel diam. mm
		w	D	H	w	d			
pr-4001	P	490	635	1025	295	390	14.0	150	220 x 70
pr-4000	TR	475	625	1025	295	390	11.0	150	200 x 40

P = Pneumatic tyres, TR = Thermoplastic rubber tyres



Parcel truck, double-fold version

Article no.		Dimension mm			Toe plate mm		Weight kg	Load cap. kg	Wheel diam. mm
		w	D	H	w	d			
pr-4003	P	490	635	1025	295	390	15.5	100	220 x 70
pr-4002	TR	475	625	1025	295	390	12.0	100	200 x 40

P = Pneumatic tyres, TR = Thermoplastic rubber tyres

Tyre handling



Tyre trucks

Welded steel construction; For tyre diameter 540 - 820 mm; With wheel protection guards; Makes it easy to pick up, transport and set down whole stacks of tyres; Large push bar with soft plastic grip cover black; Lever system with gas pressure springs; Frame powder-coated RAL 5010 gentian blue; Moveable pickup arms powder-coated RAL 3000 flame red; Permanent surface protection; Impact- and scratch-resistant, or galvanised; Pneumatic tyres on steel wheel rim or solid-rubber tyres on special plastic wheel rim with precision deepgroove ball bearings and plastic wheel cap; Tyre truck with telescopic extension, extensible in 4 steps and with supporting wheels; Supporting wheels of grey non-marking thermoplastic rubber tyres on plastic wheel rim with precision deepgroove ball bearings; Thread guard; 2 swivel castors; With gas pressure spring and non-slip pedal on each axle.



Tyre truck, low

Article no.		Dimension			Weight kg	Load cap. kg	Wheel diam. mm
		w	mm D	H			
sk-710.302	P	705	660	1165	19.0	200	260 x 85
sk-710.303	SR	705	660	1165	21.0	200	260 x 65

P = Pneumatic tyres, SR = Solid-rubber tyres

Tyre truck, high

Article no.		Dimension			Weight kg	Load cap. kg	Wheel diam. mm
		w	mm D	H			
sk-710.300	P	705	740	1600	22.0	200	260 x 85
sk-710.301	SR	705	740	1600	23.0	200	260 x 65

P = Pneumatic tyres, SR = Solid-rubber tyres

1 non-slip pedal each on axle and supporting wheel

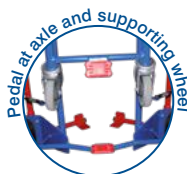

Tyre truck with supporting wheels

Article no.		Dimension			Weight kg	Load cap. kg	Wheel diam. mm
		w	mm D	H			
sk-710.304	P	705	740	1600	26.0	200	260 x 85
sk-710.305	SR	705	740	1600	28.0	200	260 x 65

P = Pneumatic tyres, SR = Solid-rubber tyres



Tyre truck with telescopic extension complete extended and loaded with 2 sets of wheels



Tyre truck with telescopic extension

Article no.		Dimension			Weight kg	Load cap. kg	Wheel diam. mm
		w	mm D	H			
sk-710.306	P	705	740	1275 - 1905	27.0	200	260 x 85
sk-710.307	SR	705	740	1275 - 1905	29.5	200	260 x 65

P = Pneumatic tyres, SR = Solid-rubber tyres



Tyre truck, low, galvanised

Article no.		Dimension			Weight kg	Load cap. kg	Wheel diam. mm
		W	mm D	H			
sk-710.312	P	705	660	1165	19.0	200	260 x 85
sk-710.313	SR	705	660	1165	21.0	200	260 x 65

P = Pneumatic tyres, SR = Solid-rubber tyres



Tyre truck, high, galvanised

Article no.		Dimension			Weight kg	Load cap. kg	Wheel diam. mm
		W	mm D	H			
sk-710.310	P	705	740	1600	22.0	200	260 x 85
sk-710.311	SR	705	740	1600	23.0	200	260 x 65

P = Pneumatic tyres, SR = Solid-rubber tyres



Tyre rack and tyre trolley

Welded steel construction; Incl. document pocket DIN A4 high; Galvanised connecting tubes; Boltmounted; Hence variable width; Suitable for wheel diameters of 540 - 820 mm; Rack and trolley powder-coated RAL 5010 gentian blue; Permanent surface protection; Impact- and scratch-resistant; Grey non-marking thermoplastic rubber tyres on plastic wheel rim with precision deepgroove ball bearings; Thread guard and foot guard; 2 swivel castors with brakes and 2 fixed castors, or 4 plastic feet.

Tyre rack with 2 levels

Article no.	Dimension			Loading surface		Weight kg	Load cap. kg
	W	mm D	H	w	mm d		
sw-646.004	1205	750	1325	1140	395	23.0	300

Load capacity tube: 150 kg*

Additional article - Connection tube galvanised for tyre rack and trolley

Article no.	Description
zsw-646.104	Connection tube for using length = 940 mm (4x till 225 mm tyres per level)
zsw-646.103	Connection tube for using length = 1800 mm (8x till 225 mm tyres per level)

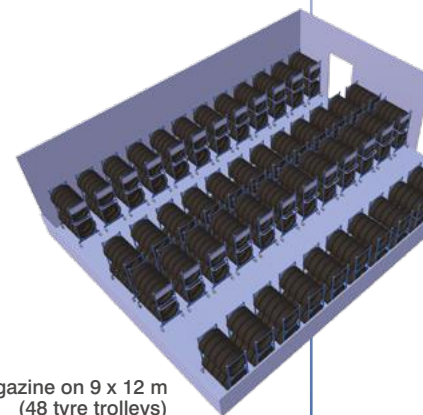

Tyre magazine on 9 x 12 m (48 tyre trolleys)



Tyre trolley with 2 levels

Article no.	Dimension			Loading surface		Weight kg	Load cap. kg	Wheel diam. mm
	W	mm D	H	w	mm d			
sw-646.003	1205	780	1430	1140	395	27.0	300	125 x 32

Load capacity tube: 150 kg*
Swivel castors with wheel brakes and foot guards for your safety!

*Total load of the transport device must not be exceeded!

Accessories for tyre rack and tyre trolley



Shelf for tyre rack and tyre trolley

Welded steel construction; Galvanised connecting tubes; Boltmounted; Suitable for wheel diameters of 540 - 820 mm; Inserting the shelf means that the middle shelf can then only be used for wheel diameters 540 - 650 mm; Shelf powder-coated RAL 5010 gentian blue; Permanent surface protection; Impact- and scratch-resistant.

Additional article - Shelf for tyre rack and tyre trolley

Article no.	Dimension			Loading surface		Weight kg	Load cap. kg
	W	mm D	H	w	d		
gsw-646.003	1205	605	750	1140	395	11.0	150

Distance pieces

Putting the galvanised distance pieces in the tubes of the tyre rack/trolley you can store wheels with diameter up to 820 mm instead of 650 mm in the second level even if a further level is installed.



Additional article - Distance pieces for tyre rack and tyre trolley

Article no.	Piece	Dimension	Weight kg
		mm W	
zsw-646.009	4	160	0.4

Additional article - Plastic clips for tyre rack and tyre trolley

Article no.	Piece	mm Ø	Dimension	Weight kg
zsw-646.005	4	33.7	670 mm for lower pipes of the tyre truck	0.8
	2		300 mm for right pipes of the tyre truck	
	2		270 mm for left pipes of the tyre truck (clipboard)	



Additional article - Plastic clips for shelf for tyre rack and tyre trolley

Article no.	Piece	mm Ø	Dimension	Weight kg
zsw-646.006	4	33.7	275 mm for pipes of the upper level	0.4
	4		260 mm for pipes of the lower level	





Additional article - Plastic feet for tyre rack

Article no.	Dimension		Weight	Load cap.
	Piece	mm	kg	kg
zsw-646.007	4	70	0.8	300

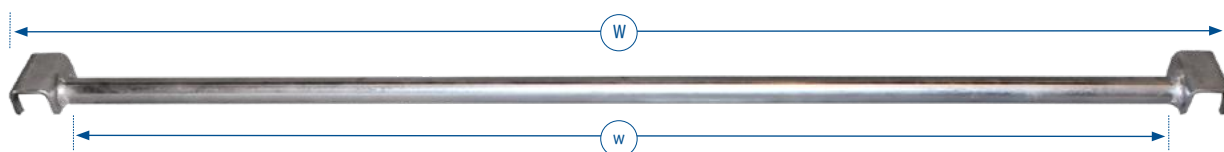

Make 3 out of 2

Additional article - Extension tube for tyre rack and tyre trolley

Article no.	Piece	Dimension			Weight	Load cap.
		mm	mm	mm	kg	kg
		ø	W	w		
zsw-646.008	2	26.9	1220	1130	2.0	150



Additional article - Push/pull bar for tyre trolley

Article no.	Dimension	Weight
	mm	kg
zsw-646.004	370	1.3

Handling of steel-cylinder trucks



Steel-cylinder trucks

Welded steel construction; With 1 or 2 innovative plastic safety handles; Toe of sheet steel with edge surrounded on three sides; For easy transport of steel cylinders with a capacity of 20, 40 or 50 l capacity; Diameter 210 – 250 mm; Cylinder holder with safety chains; Trucks powder-coated RAL 5010 gentian blue; Permanent surface protection; Impact- and scratch-resistant; Pneumatic or solid-rubber tyres on steel wheel rim, solid-rubber tyres with diameter 260 x 65 mm on special plastic wheel rim with precision deepgroove ball bearings and plastic wheel cap; Steel-cylinder truck with additional support roller; Additional support roller fixed welded; Not to be foldable; Grey non-marking thermoplastic rubber tyre on plastic wheel rim with precision deepgroove ball bearings; Thread guard; 1 swivel castor.

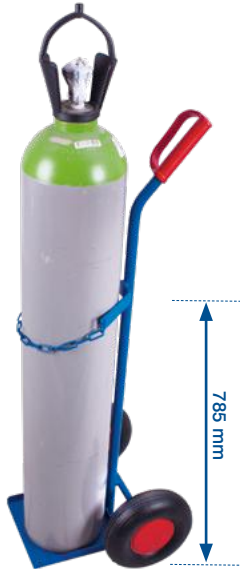

Steel-cylinder truck for 1 steel-cylinder of 40 - 50 l capacity

Article no.		Dimension			Toe plate		Weight kg	Load cap. kg	Wheel diam. mm
		W mm	D mm	H mm	w mm	d mm			
fk-1201	P	465	445	1185	255	260	9.5	100	260 x 85
fk-1200	SR	465	445	1185	255	260	11.0	100	260 x 65

P = Pneumatic tyres, SR = Solid-rubber tyres



Steel-cylinder truck for 1 steel-cylinder of 20, 40 - 50 l capacity

Article no.		Dimension			Toe plate		Weight kg	Load cap. kg	Wheel diam. mm
		W mm	D mm	H mm	w mm	d mm			
fk-1201.001	P	465	445	1185	255	260	9.5	100	260 x 85
fk-1200.001	SR	465	445	1185	255	260	11.0	100	260 x 65

P = Pneumatic tyres, SR = Solid-rubber tyres

Steel-cylinder truck for propane gas cylinder

Article no.		Dimension			Toe plate		Weight kg	Load cap. kg	Wheel diam. mm
		W mm	D mm	H mm	w mm	d mm			
fk-1206/11	P	570	555	1250	360	365	11.5	100	260 x 85
fk-1204/11	SR	570	555	1250	360	365	13.0	100	260 x 65

P = Pneumatic tyres, SR = Solid-rubber tyres

Steel-cylinder truck for propane gas cylinder

Article no.		Dimension			Toe plate		Weight kg	Load cap. kg	Wheel diam. mm
		W mm	D mm	H mm	w mm	d mm			
fk-1206/33	P	570	555	1250	360	365	11.5	100	260 x 85
fk-1204/33	SR	570	555	1250	360	365	13.0	100	260 x 65

P = Pneumatic tyres, SR = Solid-rubber tyres

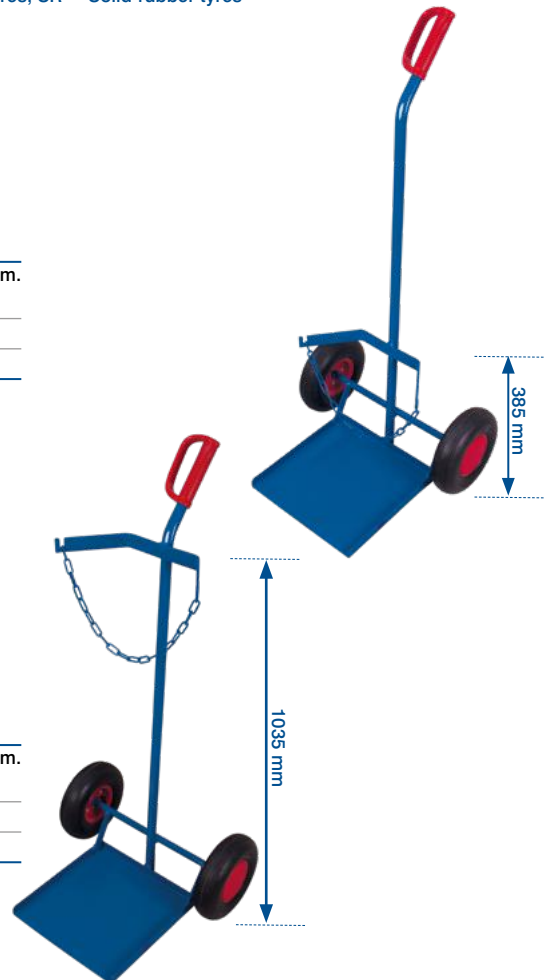

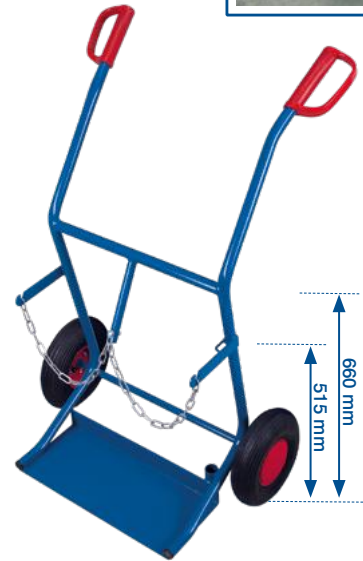

Steel-cylinder truck for 2 steel-cylinders of 20 l capacity

Article no.		Dimension			Toe plate		Weight	Load cap.	Wheel diam.
		w	D	H	w	d			
fk-1101	P	710	570	1110	470	210	15.0	100	260 x 85
fk-1100	SR	710	570	1110	470	210	17.0	100	260 x 65

P = Pneumatic tyres, SR = Solid-rubber tyres

Steel-cylinder truck for 2 steel-cylinders of 40 - 50 l capacity

Article no.		Dimension			Toe plate		Weight	Load cap.	Wheel diam.
		w	D	H	w	d			
fk-1301	P	855	975	1240	515	250	24.5	200	400 x 100
fk-1300	SR	855	975	1240	515	250	37.5	200	400 x 80

P = Pneumatic tyres, SR = Solid-rubber tyres

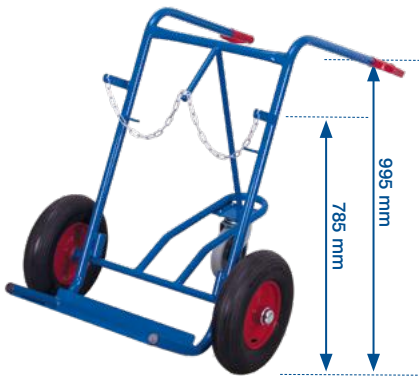

Steel-cylinder truck for 2 steel-cylinders of 40 - 50 l capacity

Article no.		Dimension			Toe plate		Weight	Load cap.	Wheel diam.
		w	D	H	w	d			
fk-1303	P	855	975	1240	515	250	29.0	200	400 x 100
fk-1302	SR	855	975	1240	515	250	42.0	200	400 x 80

P = Pneumatic tyres, SR = Solid-rubber tyres



Additional article - Toolbox for steel-cylinder trucks

Article no.	Dimension			Weight	
	w	D	H		kg
zfk-460.000	460	210	155	fk-1300 / 1301	5.0
zfk-460.001	460	210	155	fk-1000	5.0
zfk-460.002	460	210	155	fk-1100 / 1101	5.0
zfk-460.003	460	210	155	fk-1302 / 1303	5.0



VARIOfit

Handling of steel-cylinder trucks

Steel-cylinder trolleys

Welded steel construction; Push bar vertical or horizontal with dead man's brake; Additional handle beneath the push bar; 2 shelves with hole cutouts diameter 160 mm; Load surface of waterproof bonded plywood, surface finish screen printed, antislip; For 24 steel cylinders; Load capacity 80 kg; Trolley powder-coated RAL 5010 gentian blue; Permanent surface protection; Impact- and scratch-resistant; Grey non-marking thermoplastic rubber tyres on plastic wheel rim with precision deepgroove ball bearings; Thread guard and foot guard; 2 **EasySTOP** swivel castors and 2 fixed castors, or 2 swivel castors with dead man's brake and 2 fixed castors.



Steel-cylinder trolley with dead man's brake

Article no.	Dimension			Toe plate		Weight	Load cap.	Wheel diam.
	W	mm D	H	w	mm d			
sw-700.287	1280	775	1095	1120	760	63.5	500	200 x 40

Load capacity shelf: 80 kg*

Swivel castors with dead man's brake and foot guards for your safety!



Steel-cylinder trolley

Article no.	Dimension			Toe plate		Weight	Load cap.	Wheel diam.
	W	mm D	H	w	mm d			
sw-700.295	1265	775	1000	1120	760	60.0	500	200 x 40

Load capacity shelf: 80 kg*

EasySTOP swivel castors and foot guards for your safety!

Steel-cylinder truck and steel-cylinder stand

Welded steel construction; Steel-cylinder truck: toe of sheet steel with edge surrounded on three sides; For easy transport of steel cylinders with a capacity of 10 l; Diameter 140 mm; Or 40 or 50 l capacity; Diameter 210 – 250 mm; Cylinder holder with safety chains; Steel-cylinder stand incl. hole for wall fastening; Truck and stand powder-coated RAL 5010 gentian blue; Permanent surface protection; Impact- and scratch-resistant; Grey non-marking thermoplastic rubber tyres on plastic wheel rim with precision deepgroove ball bearings; Thread guard.

Steel-cylinder truck for 2 steel-cylinders of 10 l capacity

Article no.	TR	Dimension			Toe plate		Weight	Load cap.	Wheel diam.
		W	mm D	H	w	mm d			
fk-1000	TR	565	370	1045	410	210	11.5	50	200 x 40

TR = Thermoplastic rubber tyres

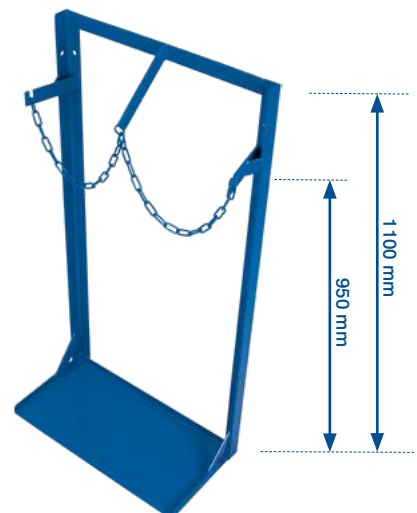

Steel-cylinder stand for 2 steel-cylinders of 40 - 50 l capacity

Article no.	Dimension			Toe plate		Weight
	W	mm D	H	w	mm d	
fk-1001	570	285	1100	555	275	13.0

*Static distributed load; Total load of the transport device must not be exceeded!



Information of steel-cylinder and drums

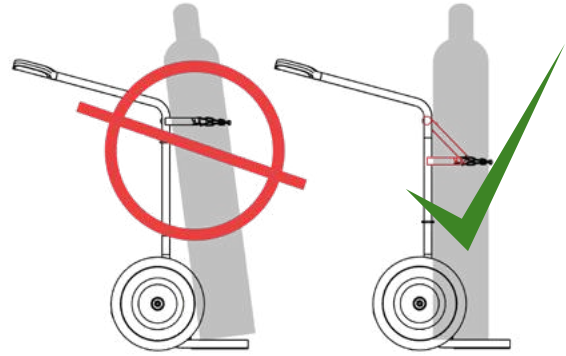

Correct positioning for increased safety

The point where the steel cylinder rests on the back of the truck is above the chain guard. This ensures that the steel cylinder is held securely and is prevented from slipping off the blade.

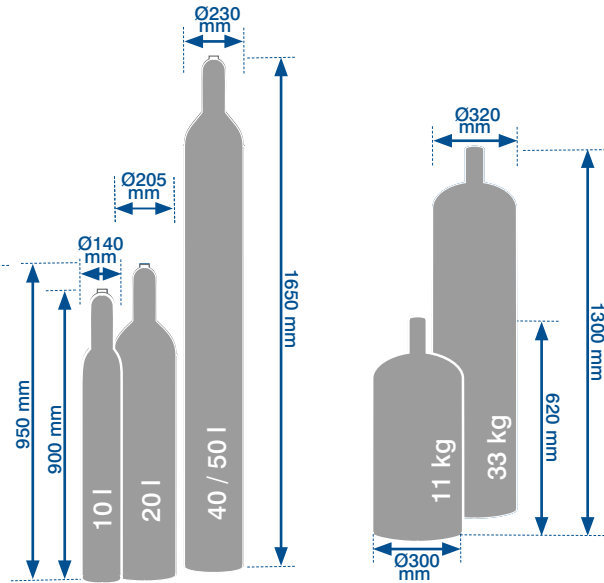
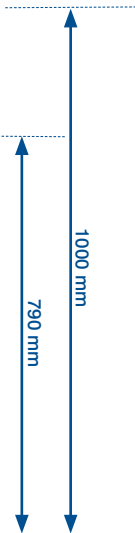

Gas cylinder

Propane gas cylinder

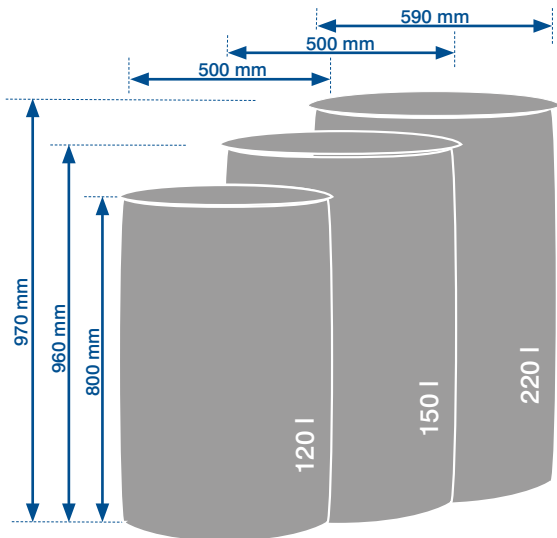

Plastic drums

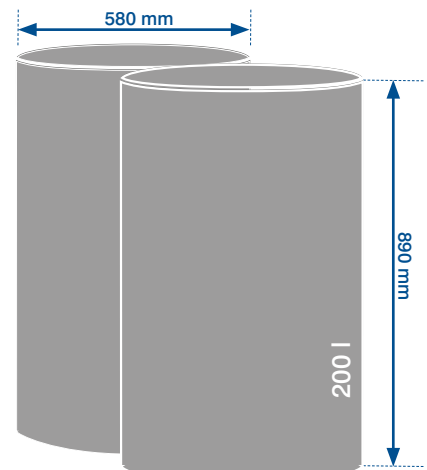

Steel sheet drums

Handling of drums



Drum dollies

Welded steel construction of flat steel; Edge height: 40 mm; For upright transport of 200 l drums; Optional with screwed push bar and webbing strap for securing load; Dollies powder-coated RAL 5010 gentian blue; Permanent surface protection; Impact- and scratch-resistant; Grey non-marking thermoplastic rubber tyres on plastic wheel rim with precision deepgroove ball bearings; Thread guard; 4 swivel castors 2 of them with brakes.

Drum dolly

Article no.		Dimension mm			Loading surface	Weight kg	Load cap. kg	Wheel diam. mm
		W	D diam.	H				
sw-610.000	TR	715	610	160	for 200 l drums	9.5	250	80 x 30

TR = Thermoplastic rubber tyre



Drum dolly with push bar

Article no.		Dimension mm			Loading surface	Weight kg	Load cap. kg	Wheel diam. mm
		W	D diam.	H				
sw-610.010	TR	715	610	930	for 200 l drums	13.5	250	80 x 30

Incl. webbing strap for securing drum
TR = Thermoplastic rubber tyres

Drum truck for plastic drums

Welded steel construction; With 2 innovative plastic safety handles; Toe of sheet steel; Bended transverse struts; Plastic skids are replaceable and mounted completely on the tube; Webbing strap for securing load; Truck powder-coated RAL 5010 gentian blue; Permanent surface protection; Impact- and scratch-resistant; Pneumatic tyres on steel wheel rim or solid-rubber tyres on special plastic wheel rim with precision deepgroove ball bearings and plastic wheel cap.

- Suitable for transporting 120 - 220 l plastic drums
- Liquid can be drained in horizontal position



Drum truck for plastic drums

Article no.		Dimension mm			Toe plate mm		Weight kg	Load cap. kg	Wheel diam. mm
		W	D	H	w	d			
fk-1110	P	660	470	1190	470	160	18.0	250	260 x 85
fk-1109	SR	660	470	1190	470	160	20.0	250	260 x 65

Incl. webbing strap for securing drum
P = Pneumatic tyres, SR = Solid-rubber tyres





Drum trolley

Fixed welded, foldable construction made of section steel; Swiveling push handle with dead man control for ergonomic handling; Push bar with black shrink tube cover; Firm and secure stand at an incline of up to 25° thanks to the newly developed, particularly strong dead man's brake; Absorption of standing drum; Includes 2 eyelets to secure the drum using the integrated tension belt; Suitable for the transport of 60 or 200 liter steel sheet drums with rim; Incl. 4 welded-on safety eyelets for fixing the drum trolley using tension belts; With 2 supporting wheels; Supporting wheels of black elastic solid-rubber tyres on cast aluminium wheel rim with precision deepgroove ball bearings; 2 swivel castors; Drum trolley powder-coated RAL 5010 gentian blue; Permanent surface protection; Impact- and scratch-resistant; Solid-rubber tyres on special plastic wheel rim with precision deepgroove ball bearings and plastic wheel cap.



4 welded-on safety eyelets for fixing the drum trolley using tension belts



Drum trolley

Article no.	SR	Dimension			Weight	Load cap.	Wheel diam.
		W	mm D	H			
zu-3344		655	1390	1040	38.0	250	260 / 125

SR = Solid-rubber tyres
Swivel castors with dead man's brake



Handling of drums



Drum trucks

Welded steel construction; With 2 innovative plastic safety handles; For transporting drums; For all 200 l drums with rim; Not suitable for plastic drums (drum truck for plastic drum on page 194); Trucks powder-coated RAL 5010 gentian blue; Permanent surface protection; Impact- and scratch-resistant; Pneumatic tyres on steel wheel rim or solid-rubber tyres on special plastic wheel rim with precision deepgroove ball bearings and plastic wheel cap; Drum truck with supporting wheels of grey non-marking thermoplastic rubber tyres on plastic wheel rim with precision deepgroove ball bearings; Thread guard.

Drum truck

Article no.	Dimension			Loading surface	Weight kg	Load cap. kg	Wheel diam. mm	
	W	mm D	H					
fk-1103	P	735	1600	410	for 200 l drums	14.0	250	260 x 85
fk-1102	SR	735	1600	410		16.0	250	260 x 65

P = Pneumatic tyres, SR = Solid-rubber tyres



Drum truck with 1 supporting swivel castor

Article no.	Dimension			Loading surface	Weight kg	Load cap. kg	Wheel diam. mm	
	W	mm D	H					
fk-1105	P	735	1445	870	for 200 l drums	18.0	250	260 x 85
fk-1104	SR	735	1445	870		20.0	250	260 x 65

P = Pneumatic tyres, SR = Solid-rubber tyres



Drum truck with 2 supporting wheels

Article no.	Dimension			Loading surface	Weight kg	Load cap. kg	Wheel diam. mm	
	W	mm D	H					
zu-3342	P	735	1430	870	for 200 l drums	19.5	250	260 x 85
zu-3341	SR	735	1430	870		21.5	250	260 x 65

P = Pneumatic tyres, SR = Solid-rubber tyres

Drum dispenser

Welded steel construction; For moving, storing and emptying 200 l steel drums; Lever with plastic safety handle; The drums rests either on 4 plastic wheels or on 2 steel rollers for thin-walled drums; Drum dispenser powder-coated RAL 5010 gentian blue; Permanent surface protection; Impact- and scratch-resistant; Polyamide tyres with precision deepgroove ball bearings, 2 swivel castors with brakes and 2 polyamide wheels on one axle.



Drum dispenser with 4 plastic wheels

Article no.	Dimension mm			Loading surface	Weight kg	Load cap. kg	Wheel diam. mm	
	W	D	H					
zu-3201	PT	895	715	690	for 200 l drums	17.5	250	125 x 40

PT = Polyamide tyres

Drum dispenser like zu-3201, but with 2 steel rollers with diameter 60 mm, length 500 mm, for thin-walled drums



Drum dispenser with 2 steel rollers

Article no.	Dimension mm			Loading surface	Weight kg	Load cap. kg	Wheel diam. mm	
	W	D	H					
zu-3202	PT	895	715	670	for 200 l drums	24.0	250	125 x 40

PT = Polyamide tyres



Drum dispenser like zu-3202, but with big drip tray 203 l, on 2 wheels with diameter 125 mm; Measurement of drip tray: 1,445 x 475 x 295 mm (W/D/H)

Drum dispenser with drip tray 203 l capacity

Article no.	Dimension mm			Loading surface	Weight kg	Load cap. kg	Wheel diam. mm	
	W	D	H					
zu-3203	PT	1505	715	670	for 200 l drums	68.5	250	125 x 40

PT = Polyamide tyres



Additional article - 10 l drip tray

Article no.	Dimension mm			Weight kg	Volume l
	W	D	H		
zu-3150	460	350	150	2.5	10

Handling of drums

Drip trays and push bar trolley with drip tray

Welded steel oil-tight; With galvanised grating; Mesh size 30 x 30 mm; For 2 or 4 drums of 200 l capacity; Optional with outlet cock; Ground clearance = 100 mm; Drip tray of push bar trolley with capacity of 42,5 l Drip trays and push bar trolley powder-coated RAL 5010 gentian blue; Permanent surface protection; Impact- and scratch-resistant; 4 or 6 feet or grey non-marking thermoplastic rubber tyres on plastic wheel rim with precision deepgroove ball bearings; Thread guard and foot guard; 2 swivel castors with brakes and 2 fixed castors.



Drip tray with grating for 2 drums of 200 l capacity

Article no.	Dimension			Loading surface		Weight kg	Load cap. kg
	W	mm D	H	w	mm d		
aw-800.000	1200	800	360	1190	790	69.0	500



Additional article - Outlet cock

Article no.	
zsw-000.500	Outlet cock
Outlet cock for articles with steel-sheet pan and self-tipper (as ex-factory equipment)	

Drip tray with grating for 4 drums of 200 l capacity

Article no.	Dimension			Loading surface		Weight kg	Load cap. kg
	W	mm D	H	w	mm d		
aw-120.000	1200	1200	285	1190	1190	84.5	1000
Outlet cock is not extent of delivery							

Drip tray with grating for 4 drums of 200 l capacity

Article no.	Dimension			Loading surface		Weight kg	Load cap. kg
	W	mm D	H	w	mm d		
aw-800.002	2390	800	250	2380	790	109.5	1000

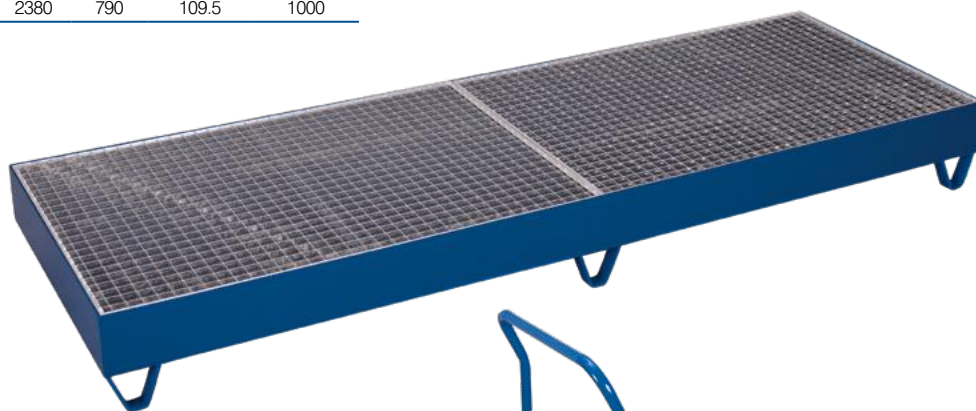

Push bar trolley with drip tray

Article no.	Dimension			Loading surface		Weight kg	Load cap. kg	Wheel diam. mm
	W	mm D	H	w	mm d			
sw-600.121	1100	600	940	990	590	37.0	250	125 x 32
Swivel castors with wheel brakes and foot guards for your safety!								



Loading and unloading



Bridge plate for loading and unloading vehicles

Lightly but strong aluminium construction; Easy and safely handling; Integrated grip holes; With positioning aids that also secure against slipping; Inclined and chamfered access areas; Anti-slip surface

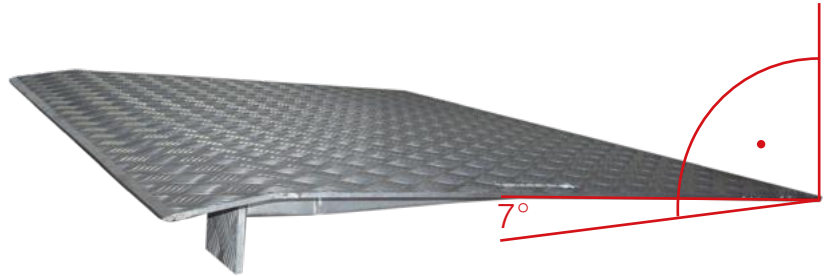

Bridge plate

Article no.	Dimension			Weight kg	Load cap. kg
	W	mm D	H		
sg-100.008	1250	995	120	35.0	1200



Ramp

Welded steel construction; The entire area of the ramp is resting on the ground when the lift truck drives in; It rises from 0 to 200 mm; Height under the lip 190 mm; Lip 10/12 mm at front, angled at 10°; Chain with hook on both sides to prevent shifting; With retractable lifting stirrup for transporting the ramp by lift truck; Colour RAL 9017 traffic black; Industrial paint.

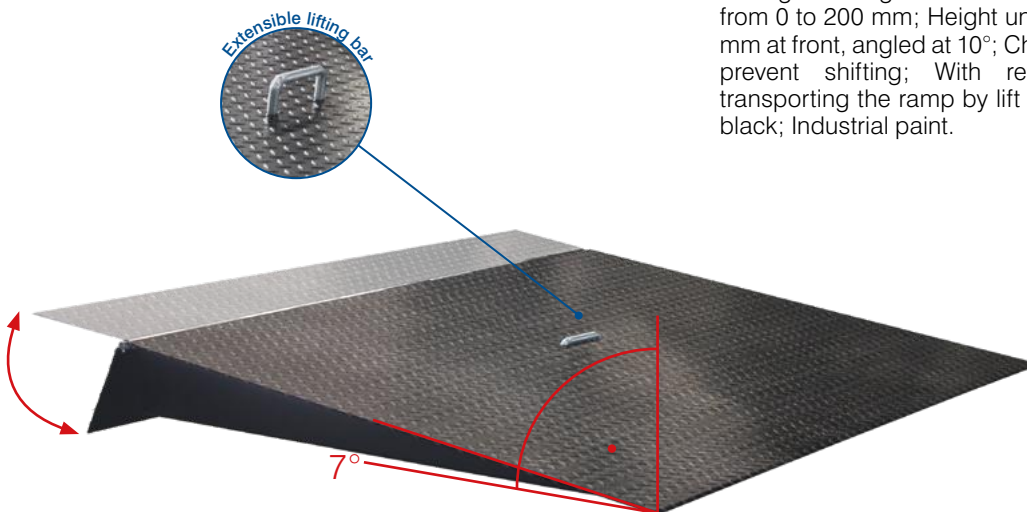

Ramp with movable lip

Article no.	Dimension			Lip depth mm	Weight kg	Load cap. kg
	W	mm D	H			
sg-200.520	2000	1815	200	300	282.5	7500

Disposal

Self-tipper for bulk material

Welded steel construction; With roll-away system; Tipping by manual release or by contact with container to be filled; Automatic return after trough is emptied; Fork-lift tunnel for safe transport; Self-tipper painted RAL 5012 light blue; Facility for retrofitting wheels; Various wheel types with different carrying capacities available as options; Optional with outlet cock (as ex-factory equipment, not additional mountable).



Self-tipper

Article no.	Dimension			Bulk-edge height mm	Weight kg	Load cap. kg	Volume l
	W	mm D	H				
sw-300.004	1375	880	615	615	93.5	1500	300
sw-500.004	1485	1400	615	615	121.0	2000	520
sw-600.004	1535	860	865	865	118.0	2000	600
sw-100.004	1525	1205	1070	1070	168.5	2000	1000



Additional articles - Wheelsets for self-tipper

Article no.		Load cap.	Wheel diam.
		kg	mm
zsw-000.500	Outlet cock (on page 198)	-	-
rsa-200.400	Thermoplastic rubber tyres	500	200 x 40
rsa-200.401	Polyamide tyres	1050	200 x 50
rsa-200.402	Elastic solid-rubber tyres	1050	200 x 50
rsa-200.403	Poyurethane tyres 92° Shore A	1500	200 x 50
rsa-200.404	Poyurethane tyres 96° Shore A	2000	200 x 50

The type of wheels used may reduce the carrying capacity

Wheelset consisting of:

2 swivel castor with brake and foot guard and 2 fixed castor



Thermoplastic rubber tyre



Polyamide tyre



Elastic solid-rubber tyre



Polyurethane tyre

Automatic reset and lock after emptying



Waste collection stands

Welded steel construction; Holder for 240 l plastic sacks; Foldable open frame for securing waste collection sack; Sack opening with 40° inclination; Waste collection stand powder-coated RAL 5010 gentian blue; Permanent surface protection; Impact- and scratch-resistant.

Waste collection stand

Article no.	Dimension			Load cap. l	Weight kg
	W	mm D	H		
sw-240.100	635	500	1210	240	13.0

Sack opening with 40° inclination

Waste collection stand

Article no.	Dimension			Load cap. l	Weight kg
	W	mm D	H		
sw-240.200	480	400	1210	240	11.0

Sack opening with 40° inclination

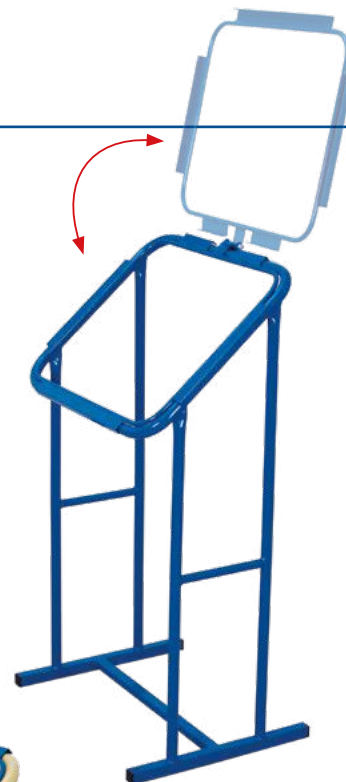

Cleaning trolley

Welded steel construction; With lockable sheet steel compartment; With holders for plastic sacks and cleaning tools; Push bars with 2 innovative plastic safety handles; Trolley powder-coated RAL 2009 traffic orange; Permanent surface protection; Impact- and scratch-resistant; Rear axle with pneumatic tyres on steel wheel rim with precision deepgroove ball bearings; Front axle with grey non-marking thermoplastic rubber tyres on plastic wheel rim with precision deepgroove ball bearings; Thread guard.



Cleaning trolley

Article no.		Dimension			Weight kg	Load cap. kg	Wheel diam. mm
		W	mm D	H			
sw-780.100	P	1125	780	1045	38.5	100	400 x 100

Incl. steel compartment with triangular lock
P = Pneumatic tyres



VARIOfit®

Handling of pallets



Steel-frame dollies for pallets

Welded steel construction; Suitable for Euro pallets or cage pallets; Incl. locating cups; Dollies powder-coated RAL 5010 gentian blue; Permanent surface protection; Impact- and scratch-resistant; Grey non-marking thermoplastic rubber tyres on plastic wheel rim with precision deepgroove ball bearings; Thread guard and foot guard, or polyamide tyres with precision deepgroove ball bearings, or elastic solid-rubber tyres on cast aluminium wheel rim with precision deepgroove ball bearings with foot guard, or polyurethane tyres 92° Shore A on cast aluminium wheel rim with precision deepgroove ball bearings with foot guard; 2 **EasySTOP** swivel castors and 2 fixed castors.



Steel-frame dolly

Article no.		Dimension			Loading surface		Weight kg	Load cap. kg	Wheel diam. mm
		W	mm D	H	w	d			
sw-870.041	TR	870	670	350	810	610	25.0	500	200 x 40
sw-870.015	TR	1070	870	350	1010	810	28.0	500	200 x 40
sw-870.000	TR	1270	870	350	1210	810	32.0	500	200 x 40
sw-870.020	TR	1270	1070	350	1210	1010	32.5	500	200 x 40

EasySTOP swivel castors and foot guards for your safety!
TR = Thermoplastic rubber tyres



Steel-frame dolly

Article no.		Dimension			Loading surface		Weight kg	Load cap. kg	Wheel diam. mm
		W	mm D	H	w	d			
sw-870.441	PT	870	670	350	810	610	25.0	1050	200 x 50
sw-870.415	PT	1070	870	350	1010	810	27.5	1050	200 x 50
sw-870.400	PT	1270	870	350	1210	810	31.5	1050	200 x 50
sw-870.420	PT	1270	1070	350	1210	1010	32.5	1050	200 x 50

EasySTOP swivel castors and foot guards for your safety!
PT = Polyamide tyres





Steel-frame dolly

Article no.		Dimension			Loading surface		Weight kg	Load cap. kg	Wheel diam. mm
		w	mm D	H	w	d			
sw-870.042	ER	870	670	350	810	610	29.5	1200	200 x 50
sw-870.036	ER	1070	870	350	1010	810	32.5	1200	200 x 50
sw-870.001	ER	1270	870	350	1210	810	35.5	1200	200 x 50
sw-870.501	ER	1270	1070	350	1210	1010	37.5	1200	200 x 50

EasySTOP swivel castors and foot guards for your safety!
ER = Elastic solid-rubber tyres



Steel-frame dolly

Article no.		Dimension			Loading surface		Weight kg	Load cap. kg	Wheel diam. mm
		w	mm D	H	w	d			
sw-870.341	PO	870	670	350	810	610	39.0	1800	200 x 50
sw-870.315	PO	1070	870	350	1010	810	44.0	1800	200 x 50
sw-870.300	PO	1270	870	350	1210	810	47.5	1800	200 x 50
sw-870.514	PO	1270	1070	350	1210	1010	49.5	1800	200 x 50

EasySTOP swivel castors and foot guards for your safety!
PO = Polyurethane tyres

Handling of pallets

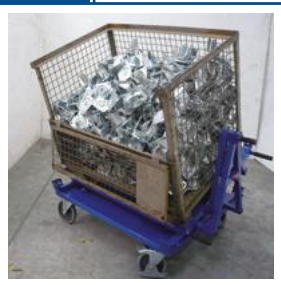

Steel-frame dollies for pallets

Welded steel construction; Suitable for Euro pallets or cage pallets; Incl. locating cups; 4 galvanised connecting tubes for insert into edges; Add-on frame stackable on connecting tubes; Variable removable; Dollies powder-coated RAL 5010 gentian blue; Permanent surface protection; Impact- and scratch-resistant; Grey non-marking thermoplastic rubber tyres on plastic wheel rim with precision deepgroove ball bearings; Thread guard and foot guard, or elastic solid-rubber tyres on cast aluminium wheel rim with precision deepgroove ball bearings with foot guard; 2 **EasySTOP** swivel castors and 2 fixed castors.



Steel-frame dolly with 2 angle-steel-frames

Article no.		Dimension			Loading surface		Weight kg	Load cap. kg	Wheel diam. mm
		w	D	H	w	d			
sw-870.113	TR	870	670	720	810	610	40.5	500	200 x 40
sw-870.114	TR	1070	870	720	1010	810	44.0	500	200 x 40
sw-870.100	TR	1270	870	720	1210	810	48.0	500	200 x 40
sw-870.506	TR	1270	1070	720	1210	1010	49.5	500	200 x 40

EasySTOP swivel castors and foot guards for your safety!
TR = Thermoplastic rubber tyres



Steel-frame dolly with 2 angle-steel-frames

Article no.		Dimension			Loading surface		Weight kg	Load cap. kg	Wheel diam. mm
		w	D	H	w	d			
sw-870.115	ER	870	670	720	810	610	45.0	1200	200 x 50
sw-870.116	ER	1070	870	720	1010	810	48.5	1200	200 x 50
sw-870.101	ER	1270	870	720	1210	810	50.5	1200	200 x 50
sw-870.507	ER	1270	1070	720	1210	1010	54.5	1200	200 x 50

EasySTOP swivel castors and foot guards for your safety!
ER = Elastic solid-rubber tyres

Accessories

Add-on frame

Welded steel construction; Incl. 4 locating corners; Height adjustment by internal spring-loaded bolt; Add-on frame can be bolted to dolly; Frame powder-coated RAL 5010 gentian blue; Permanent surface protection; Impact- and scratch-resistant.

Loading heights

- 1 650 mm 3 555 mm
- 2 605 mm 4 505 mm

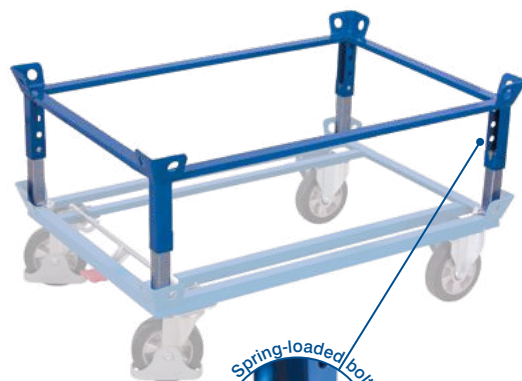
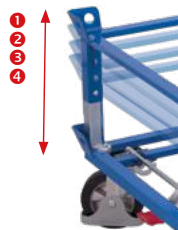

Add-on frame

Article no.	Dimension		Loading surface		Weight kg	Load cap. kg
	w	D	w	d		
zsw-870.101	870	670	810	610	14.5	in accordance with the steel- frame dolly
zsw-870.102	1070	870	1010	810	16.5	
zsw-870.103	1270	870	1210	810	17.0	
zsw-870.104	1270	1070	1210	1010	17.5	



Tipping unit for steel-frame dollies

Robust welded steel construction; Load surface of steel sheet; Basic position: horizontal position, tipping position approx. 18° to left and right; Tilting movement by "foot power" by means of 2 end-mounted foot pedals with protective cap; Locking in the three basic positions is by spring catch; Incl. locating cups and lifting rings; Suitable for **VARIOfit**® steel-frame dollies; Tipping unit powder-coated RAL 5010 gentian blue; Permanent surface protection; Impact- and scratch-resistant.

Tipping unit for steel-frame dollies

Article no.	Dimension mm			Loading surface mm		Weight kg	Load cap. kg
	w	D	H	w	d		
sw-810.004	1660	870	660	1210	810	83.0	in accordance with the steel-frame dolly

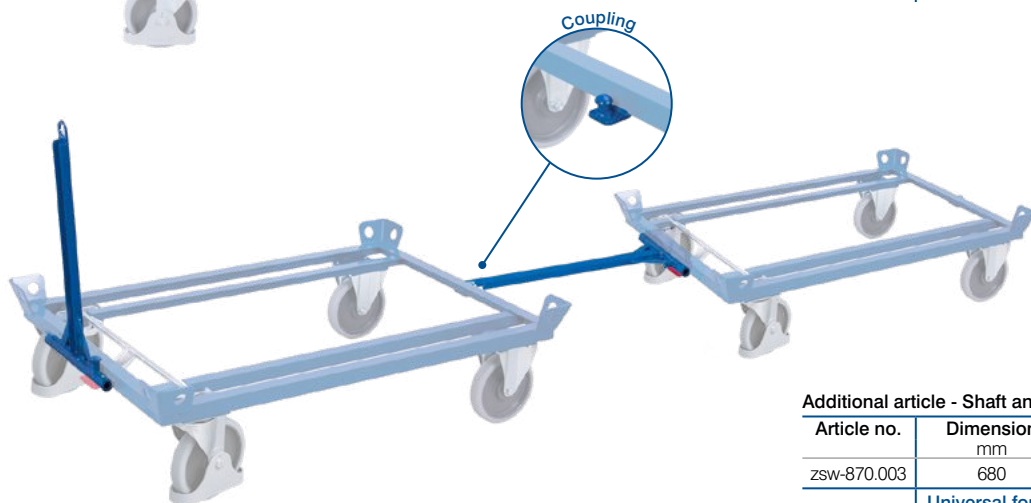

Additional article - Push bar for steel-frame dollies

Article no.	Dimension mm		Weight kg
	D	H	
zsw-870.002	500	765	Push bar 5.5

Universal for all sizes, only for combined order with steel-frame dolly (sockets fixed welded, push bar screwed)

Additional article - Shaft and coupling for steel-frame dollies

Article no.	Dimension mm		Weight kg
	w	D	
zsw-870.003	680		Shaft and coupling 5.0

Universal for all sizes, only for combined order with steel-frame dolly (fixed welded)



Additional article - Push bar with lever release for steel-frame dollies

Article no.	Dimension mm			Weight kg
	w	D	H	
zsw-870.540	500	335	825	Push bar 6.0

Universal for all sizes

Handling of pallets

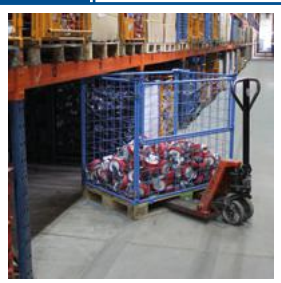

Pallet converter

Welded steel construction; Suitable for Euro and Industry pallets; Stackable, but do not move when stacked; Grilled, mesh size 100 x 100 mm; Either all sides closed, or 1 side wall with fold-down upper half; Optional replaceable pallet converter separation grid; Pallet converter painted RAL 5012 light blue; Can be collapsed or folded to save space when not in use.

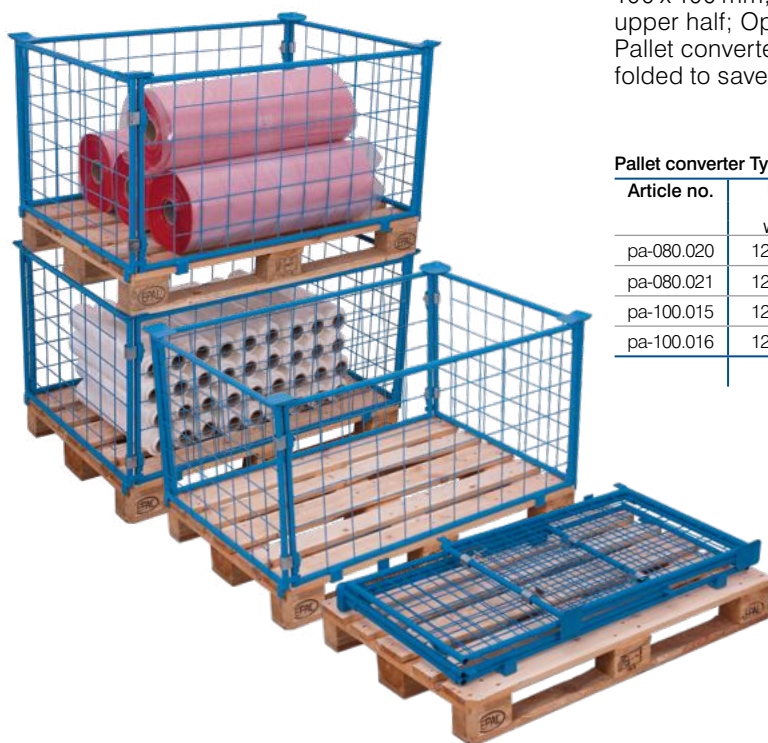

Pallet converter Type 62

Article no.	Pallet dim.		Fill height mm H	Stacking	Weight kg	Support load kg
	w mm	D mm				
pa-080.020	1200	800	400	4	16.0	1500
pa-080.021	1200	800	600	4	19.0	1500
pa-100.015	1200	1000	400	4	17.5	1500
pa-100.016	1200	1000	600	4	20.5	1500

Pallet converter Type 64

Article no.	Pallet dim.		Fill height mm H	Stacking	Weight kg	Support load kg
	w mm	D mm				
pa-080.027	1200	800	800	4	24.5	1000
pa-080.028	1200	800	1000	4	27.5	1000
pa-080.029	1200	800	1200	4	31.0	750
pa-080.030	1200	800	1600	3	40.0	750
pa-100.022	1200	1000	800	4	26.0	1000
pa-100.023	1200	1000	1000	4	29.0	1000
pa-100.024	1200	1000	1200	4	32.5	750
pa-100.025	1200	1000	1600	3	41.5	750



Pallet converter separation grid

Article no.	Dimension mm		Weight kg
	w	H	
zpa-080.055	750	400	2.9
zpa-080.056	750	600	3.8
zpa-100.014	950	400	3.9
zpa-100.015	950	600	4.6
zpa-080.051	750	800	4.2
zpa-080.052	750	1000	5.0
zpa-080.053	750	1200	5.8
zpa-080.054	750	1600	7.6
zpa-100.022	950	800	5.4
zpa-100.023	950	1000	5.8
zpa-100.024	950	1200	6.5
zpa-100.025	950	1600	8.8



Pallet converter separation grid, sloping

Article no.	Dimension mm		Weight kg
	w	H	
zpa-080.061	750	800 / 400	4.5
zpa-080.062	750	1000 / 500	5.2
zpa-080.063	750	1200 / 600	5.6
zpa-080.064	750	1600 / 800	7.7
zpa-100.010	950	800 / 400	5.5
zpa-100.011	950	1000 / 500	5.9
zpa-100.012	950	1200 / 600	6.6
zpa-100.013	950	1600 / 800	8.9

Mesh size 100 x 100 mm
only for Type 64

Mesh size 100 x 100 mm
only for Type 62 and 64



Pallet converter, galvanised

Welded steel construction; Suitable for Euro and Industry pallets; Stackable, but do not move when stacked; Grilled, mesh size 100 x 100 mm; Either all sides closed, or 1 side wall with fold-down upper half; Optional replaceable pallet converter separation grid; Hot-galvanised; Can be collapsed or folded to save space when not in use.

Pallet converter Type 62, galvanised

Article no.	Pallet dim. mm		Fill height	Stacking	Weight kg	Support load kg
	w	D	mm H			
vpa-080.020	1200	800	400	4	16.0	1500
vpa-080.021	1200	800	600	4	19.0	1500
vpa-100.015	1200	1000	400	4	17.5	1500
vpa-100.016	1200	1000	600	4	20.5	1500



Pallet converter Type 64, galvanised

Article no.	Pallet dim. mm		Fill height	Stacking	Weight kg	Support load kg
	w	D	mm H			
vpa-080.027	1200	800	800	4	24.5	1000
vpa-080.028	1200	800	1000	4	27.5	1000
vpa-080.029	1200	800	1200	4	31.0	750
vpa-080.030	1200	800	1600	3	40.0	750
vpa-100.022	1200	1000	800	4	26.0	1000
vpa-100.023	1200	1000	1000	4	29.0	1000
vpa-100.024	1200	1000	1200	4	32.5	750
vpa-100.025	1200	1000	1600	3	41.5	750

Pallet converter separation grid, sloping, galvanised

Article no.	Dimension mm		Weight kg
	w	H	
zpa-080.161	750	800 / 400	4.5
zpa-080.162	750	1000 / 500	5.2
zpa-080.163	750	1200 / 600	5.9
zpa-080.164	750	1600 / 800	7.7
zpa-100.110	950	800 / 400	5.5
zpa-100.111	950	1000 / 500	5.9
zpa-100.112	950	1200 / 600	6.6
zpa-100.113	950	1600 / 800	8.9

Mesh size 100 x 100 mm only for Type 64



Pallet converter separation grid, galvanised

Article no.	Dimension mm		Weight kg
	w	H	
zpa-080.155	750	400	3.1
zpa-080.156	750	600	3.8
zpa-100.114	950	400	3.9
zpa-100.115	950	600	4.6
zpa-080.151	750	800	4.4
zpa-080.152	750	1000	5.1
zpa-080.153	750	1200	5.8
zpa-080.154	750	1600	7.6
zpa-100.122	950	800	5.4
zpa-100.123	950	1000	5.8
zpa-100.124	950	1200	6.5
zpa-100.125	950	1600	8.8

Mesh size 100 x 100 mm only for Type 62 and 64

Handling of pallets



Pallet converter Type 63

Welded steel construction; Suitable for Euro and Industry pallets; Stackable, but do not move when stacked; Grilled, mesh size 100 x 100 mm; 1 side wall with V-cutout; Pallet converter painted RAL 5012 light blue; Can be collapsed or folded to save space when not in use.



Pallet converter Type 63

Article no.	Pallet dim.		Fill height mm H	Stacking	Weight kg	Support load kg
	w	D				
pa-080.023	1200	800	800	3	22.5	1000
pa-080.024	1200	800	1000	3	26.0	1000
pa-080.025	1200	800	1200	3	29.0	750
pa-080.026	1200	800	1600	3	37.0	750
pa-100.018	1200	1000	800	3	23.5	1000
pa-100.019	1200	1000	1000	3	27.0	1000
pa-100.020	1200	1000	1200	3	30.5	750
pa-100.021	1200	1000	1600	3	43.5	750

Pallet converter Type 65

Welded steel construction; Suitable for Euro and Industry pallets; Stackable, but do not move when stacked; All sides open; The stored goods can be accessed from all sides; Stabilised by hooking together 2 horizontal frames at top; Pallet converter painted RAL 5012 light blue; Can be collapsed or folded to save space when not in use.



Pallet converter Type 65

Article no.	Pallet dim.		Fill height mm H	Stacking	Weight kg	Support load kg
	w	D				
pa-080.005	1200	800	800	3	22.0	1500
pa-080.006	1200	800	1000	3	24.0	1500
pa-080.007	1200	800	1200	3	27.5	750
pa-080.008	1200	800	1600	3	31.5	750
pa-100.000	1200	1000	800	3	25.5	1500
pa-100.001	1200	1000	1000	3	27.5	1500
pa-100.002	1200	1000	1200	3	29.5	750
pa-100.003	1200	1000	1600	3	33.5	750

Pallet converter Type 63, galvanised

Welded steel construction; Suitable for Euro and Industry pallets; Stackable, but do not move when stacked; Grilled, mesh size 100 x 100 mm; 1 side wall with V-cutout; Hot-galvanised; Can be collapsed or folded to save space when not in use.



Pallet converter Type 63, galvanised

Article no.	Pallet dim.		Fill height mm H	Stacking	Weight kg	Support load kg
	W mm	D mm				
vpa-080.023	1200	800	800	3	22.5	1000
vpa-080.024	1200	800	1000	3	26.0	1000
vpa-080.025	1200	800	1200	3	29.0	750
vpa-080.026	1200	800	1600	3	37.0	750
vpa-100.018	1200	1000	800	3	23.5	1000
vpa-100.019	1200	1000	1000	3	27.0	1000
vpa-100.020	1200	1000	1200	3	30.5	750
vpa-100.021	1200	1000	1600	3	43.5	750



Pallet converter Type 65, galvanised

Welded steel construction; Suitable for Euro and Industry pallets; Stackable, but do not move when stacked; All sides open; The stored goods can be accessed from all sides; Stabilised by hooking together 2 horizontal frames at top; Hot-galvanised; Can be collapsed or folded to save space when not in use.



Pallet converter Type 65, galvanised

Article no.	Pallet dim.		Fill height mm H	Stacking	Weight kg	Support load kg
	W mm	D mm				
vpa-080.005	1200	800	800	3	22.0	1500
vpa-080.006	1200	800	1000	3	24.0	1500
vpa-080.007	1200	800	1200	3	27.5	750
vpa-080.008	1200	800	1600	3	31.5	750
vpa-100.000	1200	1000	800	3	25.5	1500
vpa-100.101	1200	1000	1000	3	27.5	1500
vpa-100.002	1200	1000	1200	3	29.5	750
vpa-100.003	1200	1000	1600	3	33.5	750

Handling of pallets



for subsequent fitting on a loaded pallet



Pallet converter with clamping device Type 65K

Welded steel construction; Suitable for Euro and Industry pallets; Stackable, but do not move when stacked; For subsequent fitting to loaded pallet; Frame parts secured by manual clamping function; Stabilised by hooking together 2 horizontal frames at top; Pallet converter painted RAL 5012 light blue; Can be collapsed or folded to save space when not in use.



Pallet converter Type 65K

Article no.	Pallet dim.		Fill height mm H	Stacking	Weight kg	Support load kg
	w	D				
pa-080.300	1200	800	800	3	26.5	1500
pa-080.301	1200	800	1000	3	30.0	1500
pa-080.302	1200	800	1200	3	32.5	750
pa-080.303	1200	800	1600	3	34.5	750
pa-100.304	1200	1000	800	3	29.0	1500
pa-100.305	1200	1000	1000	3	31.0	1500
pa-100.306	1200	1000	1200	3	32.5	750
pa-100.307	1200	1000	1600	3	36.5	750

Pallet converter Type 66

Welded steel construction; Suitable for Euro and Industry pallets; Stackable, but do not move when stacked; End walls are fitted with vertical tubular bars; Side walls open; Incl. connecting tube for stabilising the frame; Pallet converter painted RAL 5012 light blue; Can be collapsed or folded to save space when not in use.



Pallet converter Type 66

Article no.	Pallet dim.		Fill height mm H	Stacking	Weight kg	Support load kg
	w	D				
pa-080.009	1200	800	800	4	26.5	500
pa-080.010	1200	800	1000	3	29.0	500
pa-080.011	1200	800	1200	3	31.5	300
pa-100.004	1200	1000	800	4	29.0	500
pa-100.005	1200	1000	1000	3	31.0	500
pa-100.006	1200	1000	1200	3	36.5	300





Pallet converter with clamping device Type 65K, galvanised

Welded steel construction; Suitable for Euro and Industry pallets; Stackable, but do not move when stacked; For subsequent fitting to loaded pallet; Frame parts secured by manual clamping function; Stabilised by hooking together 2 horizontal frames at top; Hot-galvanised; Can be collapsed or folded to save space when not in use.



Pallet converter Type 65K, galvanised

Article no.	Pallet dim.		Fill height	Stacking	Weight	Support load
	W	D				
vpa-080.300	1200	800	800	3	26.5	1500
vpa-080.301	1200	800	1000	3	30.0	1500
vpa-080.302	1200	800	1200	3	32.5	750
vpa-080.303	1200	800	1600	3	34.5	750
vpa-100.304	1200	1000	800	3	29.0	1500
vpa-100.305	1200	1000	1000	3	31.0	1500
vpa-100.306	1200	1000	1200	3	32.5	750
vpa-100.307	1200	1000	1600	3	36.5	750

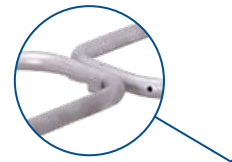

for subsequent fitting on a loaded pallet



Pallet converter Type 66, galvanised

Welded steel construction; Suitable for Euro and Industry pallets; Stackable, but do not move when stacked; End walls are fitted with vertical tubular bars; Side walls open; Incl. connecting tube for stabilising the frame; Hot-galvanised; Can be collapsed or folded to save space when not in use.



Pallet converter Type 66, galvanised

Article no.	Pallet dim.		Fill height	Stacking	Weight	Support load
	W	D				
vpa-080.009	1200	800	800	4	26.5	500
vpa-080.010	1200	800	1000	3	29.0	500
vpa-080.011	1200	800	1200	3	31.5	300
vpa-100.004	1200	1000	800	4	29.0	500
vpa-100.005	1200	1000	1000	3	31.0	500
vpa-100.006	1200	1000	1200	3	36.5	300



Handling of pallets

Pallet converter Type 68

Welded steel construction; Suitable for Euro and Industry pallets; Stackable, but do not move when stacked; All 4 sides with diagonal tubes running from bottom corners to meet at top centre; For subsequent fitting to loaded pallet; Pallet converter painted RAL 5012 light blue; Can be collapsed or folded to save space when not in use.



for subsequent fitting on a loaded pallet



Pallet converter Type 68

Article no.	Pallet dim.		Fill height mm H	Stacking	Weight kg	Support load kg
	W mm	D				
pa-080.012	1200	800	800	3	37.5	2000
pa-080.013	1200	800	1000	3	40.5	2000
pa-080.014	1200	800	1200	3	44.0	2000
pa-080.015	1200	800	1600	3	51.5	2000
pa-100.007	1200	1000	800	3	39.0	2000
pa-100.008	1200	1000	1000	3	41.0	2000
pa-100.009	1200	1000	1200	3	45.0	2000
pa-100.010	1200	1000	1600	3	53.0	2000

Pallet converter Type 75

Welded steel construction; Suitable for Euro and Industry pallets; Stackable, but do not move when stacked; Side walls with 4 vertical tubular bars; End walls open; Pallet converter painted RAL 5012 light blue; Can be collapsed or folded to save space when not in use.



Pallet converter Type 75

Article no.	Pallet dim.		Fill height mm H	Stacking	Weight kg	Support load kg
	W mm	D				
pa-080.016	1200	800	755	4	29.0	2000
pa-080.017	1200	800	955	4	31.5	2000
pa-080.018	1200	800	1155	3	34.0	1000
pa-080.019	1200	800	1555	3	39.0	1000
pa-100.011	1200	1000	755	4	30.5	1000
pa-100.012	1200	1000	955	4	33.0	1000
pa-100.013	1200	1000	1155	3	36.0	500
pa-100.014	1200	1000	1555	3	41.0	500

Pallet converter Type 68, galvanised

Welded steel construction; Suitable for Euro and Industry pallets; Stackable, but do not move when stacked; All 4 sides with diagonal tubes running from bottom corners to meet at top centre; For subsequent fitting to loaded pallet; Hot-galvanised; Can be collapsed or folded to save space when not in use.

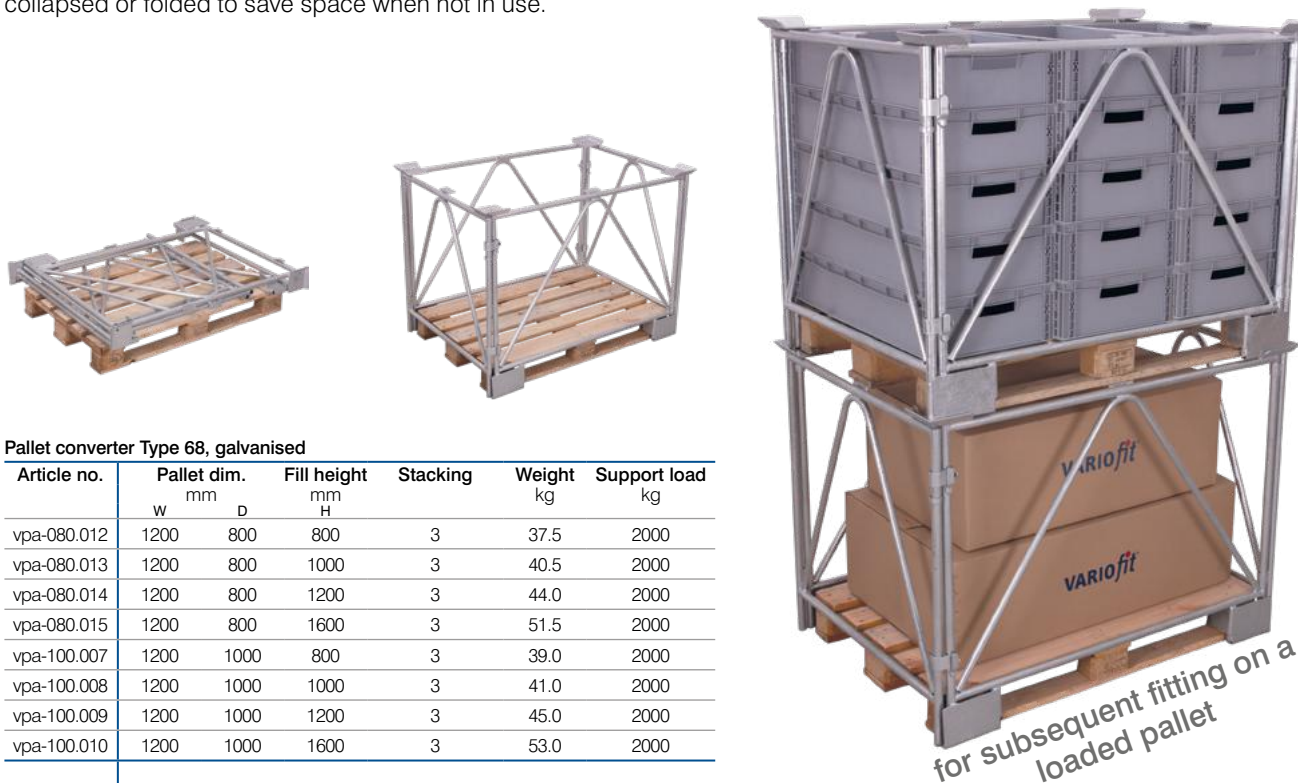

Pallet converter Type 68, galvanised

Article no.	Pallet dim.		Fill height mm H	Stacking	Weight kg	Support load kg
	W mm	D mm				
vpa-080.012	1200	800	800	3	37.5	2000
vpa-080.013	1200	800	1000	3	40.5	2000
vpa-080.014	1200	800	1200	3	44.0	2000
vpa-080.015	1200	800	1600	3	51.5	2000
vpa-100.007	1200	1000	800	3	39.0	2000
vpa-100.008	1200	1000	1000	3	41.0	2000
vpa-100.009	1200	1000	1200	3	45.0	2000
vpa-100.010	1200	1000	1600	3	53.0	2000

Pallet converter Type 75, galvanised

Welded steel construction; Suitable for Euro and Industry pallets; Stackable, but do not move when stacked; Side walls with 4 vertical tubular bars; End walls open; Hot-galvanised; Can be collapsed or folded to save space when not in use.



Pallet converter Type 75, galvanised

Article no.	Pallet dim.		Fill height mm H	Stacking	Weight kg	Support load kg
	W mm	D mm				
vpa-080.016	1200	800	755	4	29.0	2000
vpa-080.017	1200	800	955	4	31.5	2000
vpa-080.018	1200	800	1155	3	34.0	1000
vpa-080.019	1200	800	1555	3	39.0	1000
vpa-100.011	1200	1000	755	4	30.5	1000
vpa-100.012	1200	1000	955	4	33.0	1000
vpa-100.013	1200	1000	1155	3	36.0	500
vpa-100.014	1200	1000	1555	3	41.0	500

Dollies and dolly collector



Dollies

Plywood panel with non-slip covering; Colour blue; Polyamide tyres with precision deepgroove ball bearings, white; Or grey non-marking thermoplastic rubber tyres on plastic wheel rim with precision deepgroove ball bearings; Thread guard; 4 swivel castors; All dolly products are available in packaging units of 2 dollies; Non-slip cover in different colours on request!



Dollies with polyamide swivel castors

Article no.	Dimension			Loading surface		Weight kg	Load cap. kg	Wheel diam. mm
	w	mm D	H	w	mm d			
mh-934.003	600	350	145	600	350	5.0	500	100 x 36
mh-938.000	600	350	175	600	350	6.0	500	125 x 40
mh-951.013	600	300	145	600	300	5.5	500	100 x 36

Packaging units of 2 dollies



Dollies with thermoplastic rubber swivel castors

Article no.	Dimension			Loading surface		Weight kg	Load cap. kg	Wheel diam. mm
	w	mm D	H	w	mm d			
mh-935.003	600	350	145	600	350	5.5	300	100 x 32
mh-939.000	600	350	175	600	350	6.0	300	125 x 32
mh-935.020	600	300	145	600	300	5.5	300	100 x 32

Packaging units of 2 dollies

Dollies with thermoplastic rubber swivel castors (Premium)

Article no.	Dimension			Loading surface		Weight kg	Load cap. kg	Wheel diam. mm
	w	mm D	H	w	mm d			
mh-949.050	600	350	145	600	350	5.0	350	100 x 32
mh-948.050	600	350	175	600	350	6.0	350	125 x 32
mh-949.051	600	300	145	600	300	5.0	350	100 x 32

Packaging units of 2 dollies



Dolly collector

Welded steel construction; For approx. 40 dollies measuring 600 x 300 mm (W/D) or 600 x 350 mm (W/D); Dolly collector powder-coated RAL 5012 light blue; Polyamide tyres with precision deepgroove ball bearings, 4 swivel castors.

Dolly collector in special dimensions on request

Dolly collector

Article no.	Dimension			Loading surface dolly	Weight kg	Load cap. kg	Wheel diam. mm
	w	mm D	H				
mh-942.500	700	740	2000	40x	22.0	250	125 x 40



Dollies Europa

Dollies Europa

Plywood panel with rubber buffer; Surround as additional collision protection for walls and doors; Polyamide tyres with precision deepgroove ball bearings, white; Or grey non-marking thermoplastic rubber tyres on plastic wheel rim with precision deepgroove ball bearings; Thread guard; 4 swivel castors; All dolly products are available in packaging units of 2 dollies.

Dolly Europa with polyamide swivel castors

Article no.	Dimension			Loading surface		Weight	Load cap.	Wheel diam.
	w	D	H	w	d			
mh-936.003	600	350	145	600	350	5.5	500	100 x 36

Packaging units of 2 dollies



Dolly Europa with thermoplastic rubber swivel castors

Article no.	Dimension			Loading surface		Weight	Load cap.	Wheel diam.
	w	D	H	w	d			
mh-937.003	600	350	145	600	350	6.5	300	100 x 32

Packaging units of 2 dollies



Dolly Europa with thermoplastic rubber swivel castors (Premium)

Article no.	Dimension			Loading surface		Weight	Load cap.	Wheel diam.
	w	D	H	w	d			
mh-949.300	600	350	145	600	350	6.0	300	100 x 32

Packaging units of 2 dollies

More colours on request

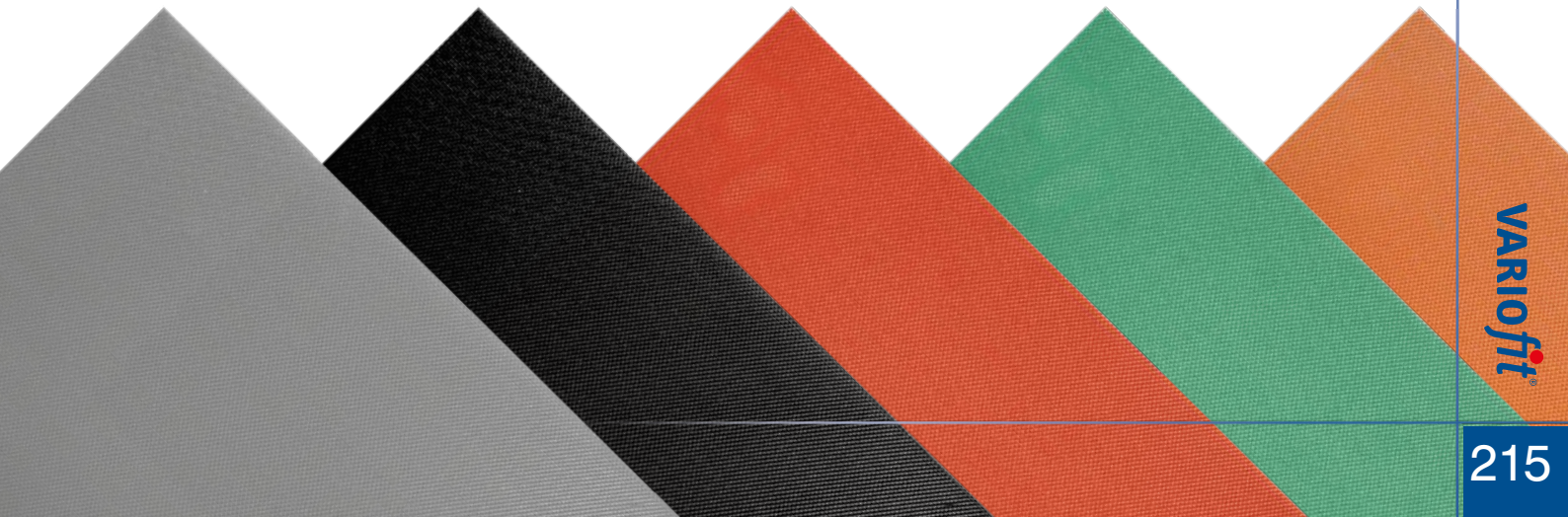

Dollies with grooved rubber mat bonded to load surface and Triple-Dogs

Dollies

Plywood panel with grooved rubber mat bonded to load surface; Colour black; Polyamide tyres with precision deepgroove ball bearings, white; Or grey non-marking thermoplastic rubber tyres on plastic wheel rim with precision deepgroove ball bearings; Thread guard; 4 swivel castors; All dolly products are available in packaging units of 2 dollies.



Dollies with polyamide swivel castors

Article no.	Dimension			Loading surface		Weight kg	Load cap. kg	Wheel diam. mm
	W	mm D	H	w	mm d			
mh-934.017	600	350	145	600	350	5.0	500	100 x 36
mh-938.500	600	350	175	600	350	6.0	500	125 x 40
mh-951.500	600	300	145	600	300	4.5	500	100 x 36

Packaging units of 2 dollies



Dollies with thermoplastic rubber swivel castors

Article no.	Dimension			Loading surface		Weight kg	Load cap. kg	Wheel diam. mm
	W	mm D	H	w	mm d			
mh-935.014	600	350	145	600	350	6.0	300	100 x 32
mh-939.500	600	350	175	600	350	6.5	300	125 x 32
mh-935.500	600	300	145	600	300	5.5	300	100 x 32

Packaging units of 2 dollies

Triple-Dog

Plywood panel, raw; Polyamide tyres with precision deepgroove ball bearings, white; Or grey non-marking thermoplastic rubber tyres on plastic wheel rim with precision deepgroove ball bearings; Thread guard; 3 swivel castors; All dolly products are available in packaging units of 2 dollies.

Triple-Dog with polyamide swivel castors

Article no.	Dimension			Loading surface		Weight kg	Load cap. kg	Wheel diam. mm
	W	mm D	H	w	mm d			
mh-540.000	540	540	145	540	540	3.0	300	100 x 36

Packaging units of 2 dollies



Dollies in special dimensions on request

Triple-Dog with thermoplastic rubber swivel castors

Article no.	Dimension			Loading surface		Weight kg	Load cap. kg	Wheel diam. mm
	W	mm D	H	w	mm d			
mh-540.500	540	540	145	540	540	3.5	200	100 x 32

Packaging units of 2 dollies



Dollies

Dollies

Plywood panel with non-slip covering; Colour blue; Polyamide tyres with precision deepgroove ball bearings, white; Or grey non-marking thermoplastic rubber tyres on plastic wheel rim with precision deepgroove ball bearings; Thread guard; 4 swivel castors; All dolly products are available in packaging units of 2 dollies; Non-slip cover in different colours on request!

Dolly with polyamide swivel castors

Article no.	Dimension			Loading surface		Weight kg	Load cap. kg	Wheel diam. mm
	W	mm D	H	w	mm d			
mh-938.024	600	600	175	600	600	10.5	900	125 x 40

Packaging units of 2 dollies



Dolly with thermoplastic rubber swivel castors

Article no.	Dimension			Loading surface		Weight kg	Load cap. kg	Wheel diam. mm
	W	mm D	H	w	mm d			
mh-950.003	600	600	255	600	600	11.5	750	200 x 40

Packaging units of 2 dollies



Wheels, castors and bearings

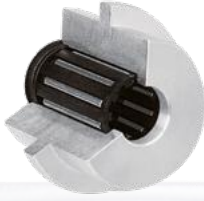

Roller bearing

Robust, sturdy, largely maintenance-free bearing; Low bearing friction; Impact-resistant; Permanent lubrication; The most widely used bearing for low-speed trucks and trolleys.



Precision deepgroove ball bearings

Sealed, maintenance-free precision deepgroove ball bearings; Guaranteed easy running when loaded, even on sloping or rough surfaces as well as on large strain and high speed; Minimum bearing friction; Impact-resistant.

What is a castor?

A Castor consists of at least one wheel, a fixed or swivelling fork and axle and a means of attachment (e.g. to a truck or trolley). There are four basic types of castors: Swivel and fixed castors with top plates, bolt-hole castors, and swivel castors with spring.



Wheel



Fixed castor



Swivel castor



Swivel castor with brake

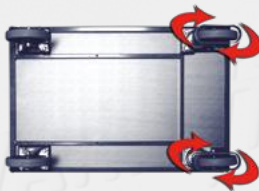

Two swivel and two fixed castors

- commonest layout
- good direction stability
- good cornering

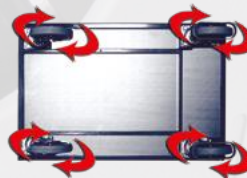

Four swivel castors

- highly manoeuvrable, suitable for cramped conditions
- improved directional stability thanks to lockable swivel castors



One swivel and two fixed castors

- suitable for light loads
- highly manoeuvrable
- tends to tip if load concentrated at front



Two swivel and two fixed castors, rhombic layout

- good direction stability
- lighty turn on spot
- tends to tip if load concentrated at corners
- fixed castors are slightly higher

Characteristics of castors

Thermoplastic rubber tyre
Standard castors by **VARIOfit**® trucks and trolleys. Suitable for the most several grounds and applications in the daily use.

- precision deepgroove ball bearing
- high carrying capacity
- low noise
- low rolling resistance
- non-marking
- high wear-resistance

- resistant to chemicals (oils, gases, acids, solvents and organic substances)
- (-20°/+80°C / 65° Shore A)

65°
Shore A



Pneumatic tyre
Suitable for uneven ground, e.g. with differences in level, especially outdoors.

- roller bearing
- low carrying capacity

- good ride comfort
- low noise



Polyamide tyre
For use on level ground in wet areas

- precision deepgroove ball bearings
- high carrying capacity

- resistant to chemicals (salts, fats, acids, alkalis)
- (-40°/+90°C / 75° Shore A)

75°
Shore A



Elastic solid-rubber tyre
Recommended for heavy loads even on poor grounds and with sensitive payloads.

- precision deepgroove ball bearing
- high carrying capacity
- low noise

- low rolling resistance
- high wear-resistance
- (-20°/+80°C / 72° Shore A)

72°
Shore A



Electrically conductive thermoplastic rubber tyre (ESD)
Suitable where there is a need to prevent static charging of the trolley and payload.

- precision deepgroove ball bearing
- high carrying capacity
- low noise

- low rolling resistance
- non-marking
- high wear-resistance
- (-20°/+80°C / 65° Shore A)

65°
Shore A



Polyurethane tyres

For use in the industrial sector with heavy loads and for mixed indoor/outdoor applications. Polyurethane can be selected specifically for your field of application.



92°
Shore A

Polyurethane tyre 92° Shore A

Suitable for high stress situations on rough ground, e.g. thresholds and outdoors areas.

- precision deepgroove ball bearing
- high carrying capacity
- low noise
- high abrasion resistance

- high cut resistance
- low rolling resistance
- high wear-resistance
- (-20°/+80°C / 92° Shore A)



96°
Shore A

Polyurethane tyre 96° Shore A

Particularly suitable in high-friction situations, e.g. for motorised trolleys.

- precision deepgroove ball bearing
- high carrying capacity
- low noise
- high abrasion resistance

- high cut resistance
- low rolling resistance
- high wear-resistance
- (-20°/+80°C / 96° Shore A)

Summary of castors

Thermoplastic rubber tyres - Fixed castor - 65° Shore A

Article no.	Dimension		Overall height mm	Top-plate outer dimension mm	Bolt hole spacing mm	Weight kg	Load cap. kg
	w mm	D mm					
bpg-200.050	200	40	235	110 x 4 x 135	75/80 x 105	1.5	225
bpg-160.050	160	40	195	110 x 4 x 135	75/80 x 105	1.4	200
bpg-125.050	125	32	155	80 x 4 x 105	75/80 x 60	0.6	110

Thermoplastic rubber tyres - Swivel castor - 65° Shore A

Article no.	Dimension		Overall height mm	Top-plate outer dimension mm	Bolt hole spacing mm	Weight kg	Load cap. kg
	w mm	D mm					
lpg-200.050	200	40	235	110 x 4 x 135	75/80 x 105	2.0	225
lpg-160.050	160	40	195	110 x 4 x 135	75/80 x 105	1.7	200
lpg-125.050	125	32	155	80 x 4 x 105	75/80 x 60	0.8	110

Thermoplastic rubber tyres - Swivel castor with brake - 65° Shore A

Article no.	Dimension		Overall height mm	Top-plate outer dimension mm	Bolt hole spacing mm	Weight kg	Load cap. kg
	w mm	D mm					
dpg-200.050	200	40	235	110 x 4 x 135	75/80 x 105	2.4	225
dpg-160.050	160	40	195	110 x 4 x 135	75/80 x 105	2.1	200
dpg-125.050	125	32	155	80 x 4 x 105	75/80 x 60	0.9	110

What does Shore mean?

Shore hardness is a material parameter for elastomers and plastics and is defined in the standards DIN EN ISO 868 and DIN ISO 7619-1. The main part of the Shore hardness tester is a spring-loaded needle made of hardened steel. The depth to which it penetrates the material to be tested is a measure of the Shore hardness which is measured on a scale of 0 Shore (2.5 millimetre penetration depth) to 100 Shore (0 millimetre penetration depth). A high number thus signifies high hardness.

Pneumatic tyres - Fixed castor

Article no.	Dimension		Overall height mm	Top-plate outer dimension mm	Bolt hole spacing mm	Weight kg	Load cap. kg	Pressure bar
	w mm	D mm						
bpl-230.000	230	65	250	110 x 4 x 135	75/80 x 105	2.0	130	3.5
bpl-200.000	200	50	235	110 x 4 x 135	75/80 x 105	1.9	75	2.5
bpl-150.001	150	30	178	80 x 4 x 105	75/80 x 60	0.8	50	2.5



Pneumatic tyres - Swivel castor

Article no.	Dimension		Overall height mm	Top-plate outer dimension mm	Bolt hole spacing mm	Weight kg	Load cap. kg	Pressure bar
	w mm	D mm						
lpl-230.000	230	65	250	110 x 4 x 135	75/80 x 105	2.5	130	3.5
lpl-200.000	200	50	235	110 x 4 x 135	75/80 x 105	2.3	75	2.5
lpl-150.001	150	30	178	80 x 4 x 105	75/80 x 60	1.0	50	2.5



Pneumatic tyres - Swivel castor with brake

Article no.	Dimension		Overall height mm	Top-plate outer dimension mm	Bolt hole spacing mm	Weight kg	Load cap. kg	Pressure bar
	w mm	D mm						
dpl-230.000	230	65	250	110 x 4 x 135	75/80 x 105	2.9	130	3.5
dpl-200.000	200	50	235	110 x 4 x 135	75/80 x 105	2.7	75	2.5
dpl-150.001	150	30	178	80 x 4 x 105	75/80 x 60	1.3	50	2.5



Additional surcharge for pneumatic tyres - set -
(Caution: lower carrying capacity)

Article no.	Dimension mm		Load cap. / trolley kg
	w	D	
rsa-230.003	230	65	390
rsa-200.003	200	50	225
rsa-150.002	150	30	150

In exchange for standard execution
*TR = Thermoplastic rubber tyres

Polyamide tyres - Fixed castor - 75° Shore A

Article no.	Dimension		Overall height mm	Top-plate outer dimension mm	Bolt hole spacing mm	Weight kg	Load cap. kg
	w mm	D mm					
bpp-200.002	200	50	235	110 x 4 x 135	75/80 x 105	1.9	350
bpp-150.000	150	40	185	110 x 4 x 135	75/80 x 105	1.5	350
bpp-125.002	125	38	155	80 x 4 x 105	75/80 x 60	1.3	200



Polyamide tyres - Swivel castor - 75° Shore A

Article no.	Dimension		Overall height mm	Top-plate outer dimension mm	Bolt hole spacing mm	Weight kg	Load cap. kg
	w mm	D mm					
lpp-200.002	200	50	235	110 x 4 x 135	75/80 x 105	2.3	350
lpp-150.000	150	40	185	110 x 4 x 135	75/80 x 105	1.8	350
lpp-125.008	125	38	155	80 x 4 x 105	75/80 x 60	1.5	200



Polyamide tyres - Swivel castor with brake - 75° Shore A

Article no.	Dimension		Overall height mm	Top-plate outer dimension mm	Bolt hole spacing mm	Weight kg	Load cap. kg
	w mm	D mm					
dpp-200.002	200	50	235	110 x 4 x 135	75/80 x 105	2.6	350
dpp-150.000	150	40	185	110 x 4 x 135	75/80 x 105	2.0	350
dpp-125.002	125	38	155	80 x 4 x 105	75/80 x 60	1.7	200



Additional surcharge of polyamide tyres - set - 75° Shore A

Article no.	Dimension mm	
	w	D
rsa-200.014	200	50
rsa-150.014	150	40
rsa-125.014	125	38

In exchange for standard execution

Elastic solid-rubber tyres - Fixed castor - 72° Shore A

Article no.	Dimension		Overall height mm	Top-plate outer dimension mm	Bolt hole spacing mm	Weight kg	Load cap. kg
	w mm	D mm					
bpg-200.006	200	50	235	110 x 4 x 135	75/80 x 105	2.8	350
bpg-160.007	160	50	195	110 x 4 x 135	75/80 x 105	2.1	300
bpg-125.007	125	40	155	80 x 4 x 105	75/80 x 60	1.5	200



Elastic solid-rubber tyres - Swivel castor - 72° Shore A

Article no.	Dimension		Overall height mm	Top-plate outer dimension mm	Bolt hole spacing mm	Weight kg	Load cap. kg
	w mm	D mm					
lpg-200.006	200	50	235	110 x 4 x 135	75/80 x 105	3.0	350
lpg-160.007	160	50	195	110 x 4 x 135	75/80 x 105	2.3	300
lpg-125.007	125	40	155	80 x 4 x 105	75/80 x 60	1.6	200



Elastic solid-rubber tyres - Swivel castor with brake - 72° Shore A

Article no.	Dimension		Overall height mm	Top-plate outer dimension mm	Bolt hole spacing mm	Weight kg	Load cap. kg
	w mm	D mm					
dpg-200.006	200	50	235	110 x 4 x 135	75/80 x 105	3.3	350
dpg-160.007	160	50	195	110 x 4 x 135	75/80 x 105	2.6	300
dpg-125.007	125	40	155	80 x 4 x 105	75/80 x 60	1.9	200



Additional surcharge for elastic solid-rubber tyres - set - 72° Shore

Article no.	Dimension mm	
	w	D
rsa-200.012	200	50
rsa-160.018	160	50
rsa-125.012	125	40

In exchange for standard execution

Summary of castors



ESD tyres - Fixed castor - 65° Shore A

Article no.	Dimension		Overall height mm	Top-plate outer dimension mm	Bolt hole spacing mm	Weight kg	Load cap. kg
	w mm	D mm					
bpg-200.036	200	40	235	110 x 4 x 135	75/80 x 105	1.6	225
bpg-160.036	160	40	195	110 x 4 x 135	75/80 x 105	1.4	200
bpg-125.036	125	32	155	80 x 4 x 105	75/80 x 60	0.8	110



ESD tyres - Swivel castor - 65° Shore A

Article no.	Dimension		Overall height mm	Top-plate outer dimension mm	Bolt hole spacing mm	Weight kg	Load cap. kg
	w mm	D mm					
lpg-200.036	200	40	235	110 x 4 x 135	75/80 x 105	2.0	225
lpg-160.036	160	40	195	110 x 4 x 135	75/80 x 105	1.7	200
lpg-125.036	125	32	155	80 x 4 x 105	75/80 x 60	1.0	110



ESD tyres - Swivel castor with brake - 65° Shore A

Article no.	Dimension		Overall height mm	Top-plate outer dimension mm	Bolt hole spacing mm	Weight kg	Load cap. kg
	w mm	D mm					
dpg-200.036	200	40	235	110 x 4 x 135	75/80 x 105	2.4	225
dpg-160.036	160	40	195	110 x 4 x 135	75/80 x 105	2.1	200
dpg-125.036	125	32	155	80 x 4 x 105	75/80 x 60	1.1	110

Additional surcharge of ESD tyres - set - 65° Shore A

Article no.	Dimension mm	
	w	D
rsa-200.016	200	40
rsa-160.016	160	40
rsa-125.016	125	32

In exchange for standard execution

Polyurethane tyres - Fixed, swivel and swivel castor with brake - 92° Shore A

Article no.	Dimension		Overall height mm	Top-plate outer dimension mm	Bolt hole spacing mm	Weight kg	Load cap. kg
	w mm	D mm					
bpt-200.001	200	50	235	110 x 4 x 135	75/80 x 105	2.5	350
lpt-200.007	200	50	235	110 x 4 x 135	75/80 x 105	2.9	350
dpt-200.001	200	50	235	110 x 4 x 135	75/80 x 105	3.4	350



Additional surcharge for polyurethane tyres - set - 92° Shore A

Article no.	Dimension mm	
	w	D
rsa-200.063	200	50

In exchange for standard execution

Polyurethane tyres - Fixed, swivel and swivel castor with brake - 96° Shore A

Article no.	Dimension		Overall height mm	Top-plate outer dimension mm	Bolt hole spacing mm	Weight kg	Load cap. kg
	w mm	D mm					
bpd-200.000	200	50	235	110 x 4 x 135	75/80 x 105	2.5	350
lpd-200.000	200	50	235	110 x 4 x 135	75/80 x 105	2.8	350
dpd-200.000	200	50	235	110 x 4 x 135	75/80 x 105	3.3	350



Additional surcharge for polyurethane tyres - set - 96° Shore A

Article no.	Dimension mm	
	w	D
rsa-200.065	200	50

In exchange for standard execution

Pneumatic tyre with groove profile

Article no.	Dimension mm		Weight kg	Load cap. kg	Pressure bar
	w	d			
lug-400.002	400	100	2.9	300	2.0

Solid-rubber tyre - 80° Shore A

Article no.	Dimension mm		Weight kg	Load cap. kg
	w	d		
ebg-400.000	400	80	11.0	450



Puncture-proof tyre

Article no.	Dimension mm		Weight kg	Load cap. kg
	w	d		
lug-390.000	390	90	3.2	150

Additional surcharge for puncture-proof tyre - pair

Article no.	Piece	Dimension mm	
		w	d
rsa-390.000	2	390	90

In exchange for standard execution (400 mm)

Accessories for trucks



Safety handle

Article no.	Piece	Weight kg
kca-000.160	1	0.2



Plastic skids

Article no.	Piece	usable for	Weight kg
kap-710.009	1	for all handtrucks with skids	0.3



Plastic cap

Article no.	Piece	usable for	Ø mm	Weight kg
k00-000.186	1	lug-260.008	117	0.1
k00-000.257	1	ebg-260.000	192	0.1



Gas pressure spring

Article no.	Version	usable for	Weight kg
k00-000.228	new	tyre trucks	0.4
k00-000.178	old		0.1

- moves 30% easier
- groove profile absorbs less dirt
- low noise moving profile

Pneumatic tyre with groove profile

Article no.	Dimension mm		Weight kg	Load cap. kg	Pressure bar
	w	D			
lug-260.008	260	65	1.5	150	2.5

Solid-rubber tyre with groove profile

Article no.	Dimension mm		Weight kg	Load cap. kg
	w	D		
ebg-260.000	260	65	2.5	200

Additional surcharge for puncture-proof tyre - pair

Article no.	Piece	Dimension mm	
		B	T
rsa-260.005	2	260	85
In exchange for standard execution (260mm)			

Puncture-proof tyre

Article no.	Dimension mm		Weight kg	Load cap. kg
	B	T		
lug-260.011	260	85	1.5	150



General accessories

Clipboard for DIN A4 of wood-based board, surface finish beech or surface coated in dark grey; With paper grip and pencil holder; Attached by tube clamps on the push bar

Article no.	Decor	Format DIN	Weight kg
zsw-000.000	beech	A4 high	1.0
zsw-000.003	beech	A4 transversely	1.5
zsw-000.000/G	grey	A4 high	1.0
zsw-000.003/G	grey	A4 transversely	1.5



Hang-on wire basket for articles on page 80

Article no.	Dimension mm			Weight kg
	W	D	H	
zu-so-1073	520	200	230	1.5



Protective strip made of plastic profile; Attached around the basic frame; Protects door frames and walls from damage, scratches, etc.; Cannot be retrofitted!

Article no.	Dimension mm	
	W	H
zsw-000.030	30	

As ex-factory equipment



Revolving buffers of light grey plastics; Suitable for narrow passages; To protect walls from damage, scratches, etc.; This increases the overall width by 70 mm; 1 set = 4 buffers; Cannot be retrofitted!

Article no.	Dimension mm	
	W	D
zsw-000.002	100	24

As ex-factory equipment

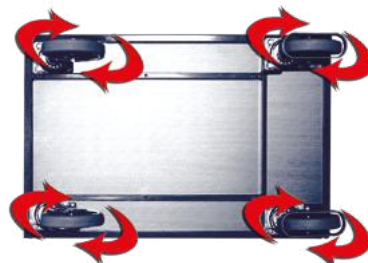
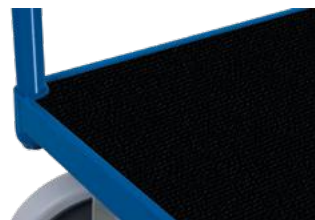
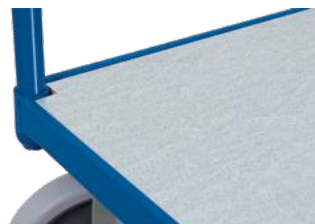

Additional surcharge for galvanised steel load surface
galvanised steel sheet folded over load surface

Article no.	Dimension mm	
	W	D
zsw-500.500	850	500
zsw-600.500	1000	600
zsw-700.500	1000	700
zsw-800.500	1200	800

As ex-factory equipment

Additional surcharge for plastic load surface abrasion-resistant surface; Weather-resistant; Resistant to oil and most acids; Recyclable

Article no.	Dimension mm	
	W	D
zsw-500.600	850	500
zsw-600.602	1000	600
zsw-700.600	1000	700
zsw-800.600	1200	800

As ex-factory equipment

Additional surcharge for 2 swivel tyres

Article no.	
rsa-000.000	TR This makes the trolley highly manoeuvrable and it can
rsa-000.004	P turn on the spot
rsa-000.005	ER

As ex-factory equipment
TR = Thermoplastic rubber tyres
P = Pneumatic tyres
ER = Elastic solid-rubber tyres

Index

A	Page	E	
Additional board	31,33,35,37,39,40,41,42,43,103,108,109,118,121,125,129,131,132-134,145	EasySTOP - Explanation -	2,5,12,13
Additional tray	119,121	Elastic solid-rubber tyres	62-65,70,75-77,86,96,97,113,165,195,200,203,204,219,221
Add-on frame	64,65,204	Electrostatic discharge	70,92,93,96,97,100-111,116,119,120,128-131,137,139,140,160,161,163,219,222
Aluminium	72,79,95,173-175,178-180,199	Environment protection	98,99,197,198
Aluminium truck	173-175,178-180	ESD trolley	100-109
Anti-slip	40,41,70,75-77,79,80,90,91,94,96,97,113,129,131,132,142-152,152,154,165,180-183,192,199,214-217	ESD tyre	100-109,219,222
Antistatic	100-109,219,222	Euro boxes	44-49,101,104,105,135-141,144,156,162
Appliance truck	182	Euro container trolley	105,132-139,156-162
B		Euro system dolly	48,49,104,156-161
Ball socket	164,165	Extension tube	189
Bicycle trailer	148	F	
Book trolley	142	Feet	85,187,189,192,198,201
Box trolley	20,21,30,31,34,39,82,83,124-127,108,109,128-131	Folding push bar trolley	14,15,78,79
Box trolley with board panels	20,21,82,83	Folding toe	169,174,185
Box trolley with mesh	18-21,74,82,83	Folding trolley	14,15,78,79
Bridge plate	199	Folding truck	185
Bulk material	200	Fork bracket	89
C		Four-sided trolley	16-21,30,31,34-39,73-75,77,82,83,108,109,124,125,127,128-131,146-150,153
C+C trolley	80	G	
Carrier-spar trolley	90,91	Galvanised	38,39,64,65,89,96,99,114-116,130,131,134,144,145,187,188,189,198,204,207,209,211,213,225
Carrie-spars	90,91	Galvanised steel load surface	96,225
Carrying bars	182	Gas pressure spring	83,94,149-151,166,186,187,224
Chair truck	180	Grating	99,198
Clamping device	210,211	H	
Cleaning trolley	201	Hand platform trolley	149-151
Clipboard	225	Hand truck	146,147
Corrugated bracket	89	Handling of drums	58,59,194-198
Coupling	66,67,145,148,151,152,205	Hang-on wire basket	80,225
Crate dolly	50,51,154	Heavy-duty trolley	62,63,70,75-77,96,97,113,149,150,152,203
Cupboard	28-29,107,111-117	Heavy-duty truck	183
D		Holder selection	115
Dead man's brake	11,72,78,93,120,126,192,195	I	
Distance piece	188	Industrial trailer	152,153
Document trolley	142,143	L	
Dolly	214-217	Light version tubular steel pushbar trolley	14,15,70
Dolly collector	214	Lightweight folding truck	185
Dolly Europa	215	Locating corners	60-65,164,202-205
Double wing door	26-29,36-39,108-110,128-131	Lock	26-29,36-39,83,92,93,106-114,116,117,128-131,143,191,201
Double-end push bar trolley	71	Long-goods dolly	77
Double-end trolley	16-19,73-76	Long-goods trolley	77
Drawbar eye	151,152	M	
Drawer	28,29,92,93,106,107,111-114,116,117	Material box	89
Drawer divider	28,29,92,93,106,107,111-114,116-117	Material crate	89,115
Drip tray	24,25,98,99,197,198	Material stand	46,47,101,140,141
Drum dispenser	197	Mesh	18-21,30-37,42,43,74,82-84,88,108,123-129,133-134,143-145,198,206-209,225
Drum dolly	58,59,194		
Drum trolley	195,198		
Drum truck	194,196		

N

Non-slip covering	40,41,79,132,154,180,182,214-217 181-183
-------------------	---

O

Oil-tight loading surface	24,25,98,99,197,198,200
Order-picking trolley	94,144,145
Outlet cock	99,198,200

P

Pallet converter	206-213
Pallet converter separations grid	206,207
Parcel trolley	30,31,124
Parcel truck	185
Pegboard tool pane	115
Pipe carrier	89
Plastic cap	52-57,58,59,87,146,148-150, 166-175,177,179,180,182,185,187
Plastic crate	44,45,136,138,139,156,161,162
Plastic load surface	225
Plastic skid	54,55,168,169,172-174,194,224
Platform trolley	69
Pneumatic tyre	52-59,87,146-150,152,166-175, 177,179,180,182,185-187,190,191, 194,196,201,219,220,223,224
Polyamide tyre	60,61,197,200,202,214-217, 219,221
Polyurethane tyre	62,63,77,165,183,200,203,219,222
Protective strip	142,143,188,225
Pull bar	36-39,108,109,128-131,145,189
Puncture-proof tyres	54,55,168,172,174,175,223,224
Push/pull bar	36-39,108,109,128-131,145,189
Push bar trolley	14,15,70-72,104,160,161,198
Push-handle dolly	50,51,105,162,163

Q

Quick-lift jack	164,165
-----------------	---------

R

Ramp	199
Reflective films	146-151
Revolving buffers	142,143,225
Roll stand	143
Roll truck	143
Roller shutter door	38,130,143
Roller shutter locking	38,130,143

S

Safety chain	56,57,190-193
Safety handle	52-57,149-150,166-180,182, 190,191,194,196,197,201,224
Screen-printed panel	70,75-77,80,94,96,97,113,129,131, 145-153,165,192
Self-tipper	200
Separation grid	206,207
Shaft	66,67,145-153,205
Sheet-material stand	85
Sheet-material trolley	85,86
Sheet-material truck	58,59,87
Shelf trolley	32-43,68,103,108,109,118-123, 125-134
Shrink hose	90,91,183,195
Side frame trolley	80,84,85

Singel-end trolley	16-19,73-76
Skid	54,55,168,169,172-174,194,224
Slide down safety	88
Slip off safety	90,91
Small order-picking trolley	44,45,105,138,139
Soft tube	36-39,66,67,72,93,108,109,120, 126,128-131,145,149,150,180,183, 185,186,187,189,192,195,205
Solid-rubber tyre	52-59,87,146-150,152,166-175, 177,179,180,182,186,187,190,191, 194,196,223,224
Stackable	164,206-213
Stacking corners	60-65,164,202-205
Stair-climber truck	54,55,176-179
Stanchion trolley	76,77
Star wheels	54,55,176-179
Steel box trolley	83
Steel frame dolly	60-63,202-205
Steel-cylinder stand	192
Steel-cylinder trolley	192
Steel-cylinder truck	56,57,190-192
Step tread	94,145
Store-room trolley	72
Supporting roller	87,166,183,186,191,195,196
System dolly	48,49,104,156-161

T

Table transporter	181
Table trolley	20-25,71,92,93,95-99,102,106
T-handle lock	26,27,36-39,108-110,129,131
Thorn bracket	89
Three-sided trolley	16-19,30,31,34,35,73-75,77, 123-125,127
Tiltable loading surface	40-43,46,47,101,105,132-137, 139-141,142,143,205
Tipping unit	205
Toolbox	191
Trailer	148,152-153
Tray	95,118,119,121
Triple-Dog	216
Tubular bar	71,76,77,80,84,85
Tubular-steel truck	52,53,166-172
Tubular-support trolley	85
Turnable steering	149-153
Two-wheeled platform	164,165
Tyre rack	187
Tyre trolley	187
Tyre truck	186,187
Tyre truck with telescopic extension	186

W

Wall	16-21,30-39,73-77,82-84,108, 109,146-150,153,164,206-209
Waste collection stand	201
Waterproof	70,72,75-77,80,94,96,97,113, 129,131,142,143,145-153,165,192
Workpiece trolley	88
Workshop trolley	26-29,107,110-117



www.variofit.eu

Cordes GmbH & Co. KG
Weißfelder Straße 1
D - 21698 Harsefeld
tel.: +49 (0) 4164 816 0
fax: +49 (0) 4164 816 28 300
email: info@cordes.eu
info@variofit.eu

Transport Systems

Your **VARIOfit**® dealer

