



---

**SATELLIET**<sup>®</sup>  
ORIGINALS

---



BE AN  
ORIGINAL



Satelliet Originals originated from the need to create a European hospitality furniture collection with its own recognisable signature. This also includes a strong message. A message that clarifies what Satelliet Originals stands for. Be an original is about just being yourself. That alone is what makes you unique. Every product that is created by our designers embodies hospitality, quality, strength, diversity, individuality, inspiration, relevance and functionality. That is the promise of Satelliet Originals.

# Brand New.

Brand new Originals

9

# Designers.

Erik Remmers	13
Elise Luttk	19
Jan Dijkstra	23
Lars Snellaars	33
Hofmeijer & Dekker	41
Dirk van Sliedregt	47
Studio Satelliet	51
Paul Philipsen	71
Diederik Schneemann	77
Buro NOW	81
Jon + Sven	87
Frans Schrofer	91
Dave Keune	103
Gerard van den Berg	109
Ardie van Bommel	113
Tom Frencken	117



# About Originals.

Be an Original	3
Sustainability	6
Hospitality proof	7
Tailor made	7
Designers	11

# Collections.

Pebble	17
Chester	21
Cozito	25
Fioli	27
Olyn	29
Norwe	31
ReUnited	35
Circl	39
25.25	43
Steelwood	45
550	49
Calypso	53
Manado	55
Lux	57
Canu	59
Chantilly	63
Current	65
Gerlin	67
Code	69
S-17	73
Tube	79
Biscuit	83
Oso	89
Mistral	93
Loop	97
Orbit	99
Gelato	101
Brewer	105
Forge	107
Montana	111
Ear	115
Legs	119

# SUSTAINABLE HOSPITALITY PROOF TAILOR MADE



**'Waste isn't waste  
until we waste it.'**



still usable materials

We work hard on the future of sustainable hospitality furniture. We do this by continuously making sustainable decisions and use SUM - Still Usable Materials – for the creation of great new products. At Originals we strongly believe that contemporary and sustainable furniture items should be used in an

interior concept because they are beautiful and comfortable. In this way you unconsciously, yet consciously, contribute to a sustainable future, without compromising on appearance and quality. When you strive for sustainability beautiful collaborations arise. Together we can make the difference.



### Touch of hospitality

Satelliet hospitality furniture has been established in 1971 in The Netherlands and has become an authority in the field of hospitality furniture. Hospitality is on the rise in more and more markets. Atmosphere goes above and beyond pure functionality, but comfort and quality will always be in style. With Satelliet

Originals we want to offer creatives in the hospitality interior sector the tools to deliver our promise on a larger scale. We believe that sharing our creativity and expertise in the form of a contemporary furniture collection will contribute to the creation of unique hospitality locations: places where people like to meet.



### Tailored design

Satelliet Originals' collection is unique and responds to the ever-changing needs of users and guests. Each piece of furniture in the Originals collection has its own character, its own face, and in this way supports the identity of a concept or interior. We know that every project is unique and that this requires

a wide and broad range of possibilities. The real strength of Satelliet Originals therefore lies in customisation. Due to the extensive choices in material and design, the possibilities with Satelliet Originals are unprecedented. Models, materials and colours must feel like a tailored suit.

# BRAND NEW.



▲ Loop



▲ Code



## Meet our brand new Originals

Through years of experience in the hospitality furniture industry we are fully aware that trends follow each other at lightning speed. For this reason we are always searching for the latest developments and trends to inspire us. All with the aim to offer a qualitative and up-to-date collection. By being at the basis of every product within the

Satelliet Originals collection, we are able to respond quickly to the continuously changing wishes and needs of the market. Together with the versatile team of designers and our knowledge of the market trends, technical developments and materials we created Brand New Originals. All available to you to realize on point hospitality interiors.



▲ Orbit



▲ Chester



▲ Chantilly



▲ Calypso



▲ Gelato



▲ Pebble



▲ Stijn van Woerkom

▲ Frans Schrofer

Ardie van Bommel ▲

▲ Erik Remmers

Jan Dijkstra ▲

Wessel Storms ▲

# Designers.



▲ Chris Montijn-Spiering

▲ Jesse Visser

▲ Gerard van den Berg

▲ Tom Frencken

▲ Elise Luttkik

Dave Keune ▲

## Meet our designers

What makes our collection truly original? The designers behind the unique designs. Satelliet Originals is not just a label with a versatile collection, there is also a very versatile team of progressive designers behind it. All of them believe that together you can achieve more than alone. These

collaborations are unique and give an extra dimension to the brand and the products. The eye, the hand and the heart of the designer, that's where Satelliet Originals makes the difference. It is a feeling, an emotion. Meet the designers and their Originals here.





I am a wood enthusiast. Wood brings charm and suits my accessible design style, which is simple and without fuss.

Erik Remmers

Be an original.

Erik Remmers

Designer Erik Remmers rediscovered his love for product design. After studying furniture design, he joined a design agency 14 years ago and focused on interior design. Recently, he took up his sketchpad again and designed the wooden Pebble chair, lounge chair and bar stool for Satelliet Originals, as a counterpoint to what he sees as the one-sided supply of steel-framed furniture.

#### DESIGNED FOR SATELLIET ORIGINALS

- Pebble

#### ABOUT



Scan the QR code for more information.



# Be an original.

A graceful and sturdy design.

PEBBLE - ERIK REMMERS





**PEBBLE** ORGANICALLY SHAPED, BEAUTIFULLY ROUND AND CUDDLY, BUT AT THE SAME TIME STURDY AND ROBUST. PEBBLE HAS A FRIENDLY APPEARANCE AND OWES HIS NAME TO THE ROUNDED SHAPE OF THE SEAT AND BACK. THE DESIGN IS GRACEFUL, BUT THE WOODEN FRAME MAKES THE CHAIR TOUGH AND DISTINCTIVE.





PEBBLE SC



PEBBLE HS



PEBBLE LSC

# PEBBLE

A design by Erik Remmers for Satelliet Originals, inspired by the round and flattened shape of a pebble. Pebble steals the show with this distinct 'future heritage look'. Pebble has slender, tapered legs and a beautiful curved wooden detail at the back against the softly upholstered back." The Pebble is available as chair, stool and lounge chair.

## MATERIALS

frame	solid beechwood
frame finishing	lacquered
seat / back	upholstered, full

## EXTRA

stackable	no
outdoor	no
CMHR foam	optional

## COLOURS

frame	walnut, classic walnut, wenge, mahogany, cognac, classic honey, blank, matte blank, carbon, clay
seat / back	fabric or leather, Satelliet collection or supplier

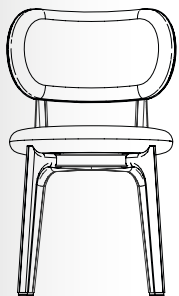

h h A h  
80 51 45 48

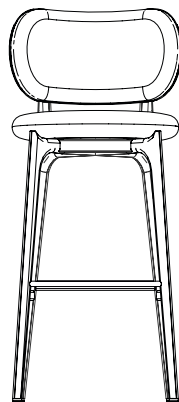
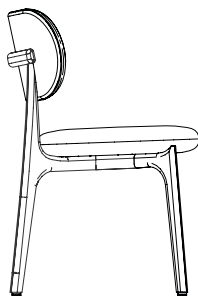

h h A h  
107 56 46 80

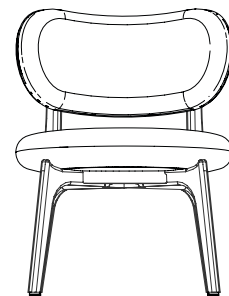
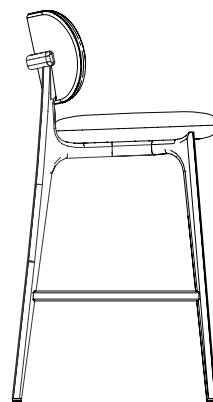

h h A h  
71 60 55 43





I enjoy the puzzle of aesthetics and poetry on the one hand, and construction and production methods on the other.

Elise Luttk

Be an original.

Elise Luttk

As a Master of Science in Integrated Product Design graduated in 2007 from TU Delft, Elise Luttk's work is always characterized by well-thought-out technology and construction. She looks for ways to materialize illusions, using transparency, iridescent effects and rupture of light. Like the illusion of cushioning used in Chester chair.

**DESIGNED FOR SATELLIET ORIGINALS**

- Chester

**ABOUT**



Scan the QR code for more information.



**CHESTER** CHESTER CHAIR TRANSLATES THE CLASSY STYLE OF THE ICONIC CHESTERFIELD CHAIR TO CONTEMPORARY TIME. WITH MODERN TECHNIQUES, ASH WOOD IS MADE TO MATCH THE NOBLESSE OF THE ORIGINAL LEATHER LUXURY.



CHESTER SC

# CHESTER

Chester Chair is designed for Satelliet Originals by Elise Luttik. She captured the softness and pattern of the iconic Chesterfield leather upholstery in wood. This 'new classic' is designed to fit dining tables in pronounced hospitality concepts. The seat features flat upholstery that enhances the uniqueness of the design. It creates additional creative possibilities and increases comfort.

## MATERIALS

frame	hardwood, ashwood
frame finishing	lacquered
seat	wood or upholstered
back	hardwood, ashwood

## EXTRA

stackable	no
outdoor	no

## COLOURS

frame	walnut, classic walnut, wenge, mahogany, cognac, classic honey, blank, matte blank, carbon, clay
seat / back	wood or upholstered

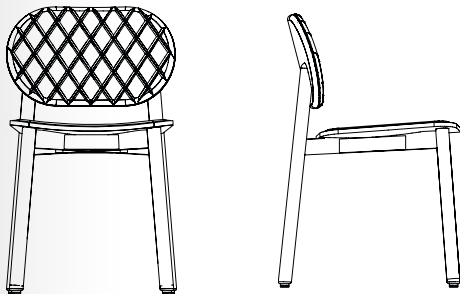

h	h	A	h
79	41	46	46





My design style can be described as friendly, cheerful, sympathetic and always a bit quirky.

Jan Dijkstra

Be an original.

Jan Dijkstra

In 2005 Jan Dijkstra graduated from the Design Academy in Eindhoven as an industrial designer and started his own studio: studio JanJannes. From there on Jan developed his own style that he describes as 'friendly, cheerful, sympathetic and always a bit quirky'. Jan brings his design to life by making optimal use of his creativity and imagination.

#### DESIGNED FOR SATELLIET ORIGINALS

- Cozito
- Fioli
- Norwe
- Olyn

#### ABOUT



Scan the QR code for more information.



**COZITO** STEEL FRAMES ARE BEING USED IN INCREASINGLY INGENUOUS WAYS IN FURNITURE DESIGN. IN THE CASE OF THE COZITO, A STRIKING STEEL DETAIL HAS BEEN ADDED TO THE BACK OF THIS CHAIR. IN COMBINATION WITH THE UPHOLSTERY OF THE SEAT AND THE EXTRA HIGH BACKREST, IT IS SIMPLY A STRIKING DESIGN WITH ITS OWN CHARACTER.





COZITO AC



COZITO HS



# COZITO

Cozito was exclusively designed for Satelliet Originals by the Dutch product and furniture designer Jan Dijkstra. The Cozito has a wired, steel frame with an upholstered seat and back. It is simply an eye-catching chair with its own character. The Cozito is also available as an armchair and a stool.

## MATERIALS

frame	metal, steel
frame finishing	powder coated
seat	upholstered
back	wire steel, upholstered

## EXTRA

stackable	no
outdoor	no
CMHR foam	yes

## COLOURS

frame	black standard, various RAL colours (request)
seat / back	fabric or leather, Satelliet collection or supplier

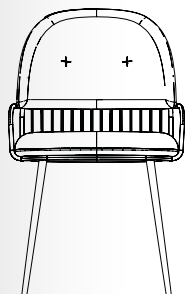

h h A h  
81 51 51 45

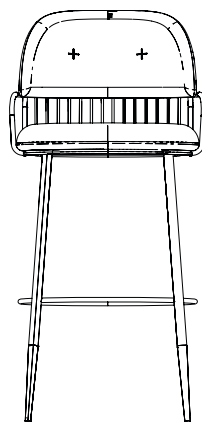

h h A h  
112 51 51 80

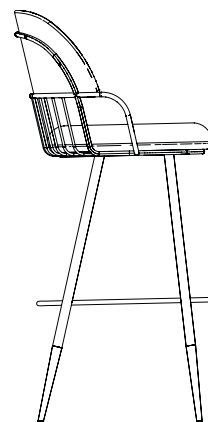



FIOLI AC

FIOLI LAC

FIOLI HS

## FIOLI FAMILY

Fioli is exclusively designed for Satelliet Originals by the Dutch designer Jan Dijkstra. The steel framework of the Fioli makes the chair a special one. Not only for its edgy look, but because the steel frame follows the contour of the seat. The seat and back are fully upholstered for maximum comfort.

### MATERIALS

frame	metal, steel
frame finishing	powder coated
seat shell	upholstered, flat

### EXTRA

stackable	no
outdoor	no
CMHR foam	yes

### STANDARD COLOURS

**FRAME** RAL 1005 honey yellow, RAL 1036 pearl gold, RAL 3004 purple red, RAL 3012 beige red, RAL 5003 sapphire blue, RAL 5020 oceanblue, RAL 6011 reseda green, RAL 7016 anthracite grey, RAL 7021 black grey, RAL 7042 traffic grey a, RAL 9005 jet black, RAL 9010 pure white, NCS 2005-B80G misty grey, NCS 4050-Y60R russet orange, NCS 5020-R80B koi blue, NCS 7010-G10Y hunter green

**SEAT / BACK** fabric or leather, Satelliet collection or supplier

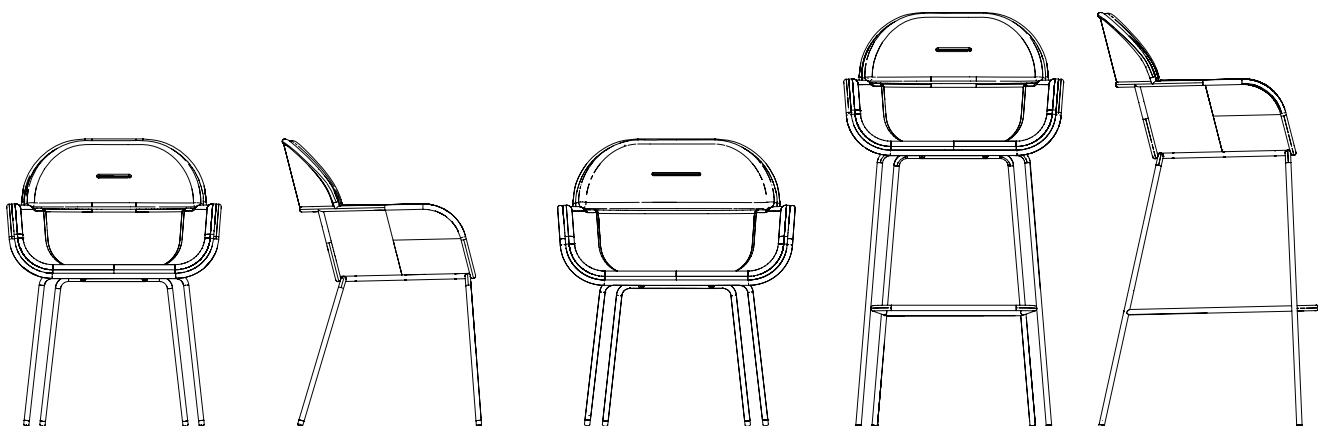

h h A h  
79 63 62 46

h h A h  
76 64 66 43

h h A h  
115 63 62 80



**FIOLI** THE DESIGN OF THE FIOI IS INSPIRED BY ROSE PETALS. THE PETALS' ROUND, OPEN SHAPE LOOKS CHEERFUL, FRIENDLY AND INVITING. THE STEEL FRAME OF THE FIOI ELEGANTLY DEFINES THE CONTOURS OF THIS DESIGN. THE MOULDED SEAT SHELL CONTINUES UNDER THE ARMRESTS.



OLYN SC



OLYN AC



OLYN HS-WB



OLYN HS

## OLYN FAMILY

The Olyn series, designed exclusively for Satelliet Originals by Jan Dijkstra, has a steel frame that standardly comes in the colour matte black. The seat and back are upholstered in a fabric or leather of choice. The family consists of a side chair, an armchair and a stool with or without backrest.

### MATERIALS

frame	metal, steel
frame finishing	matt black powder coated
seat / back	upholstered, flat
armrests	upholstered

### EXTRA

stackable	no
outdoor	no

### COLOURS

frame	black standard, various RAL colours (request)
seat / back	fabric or leather, Satelliet collection or supplier

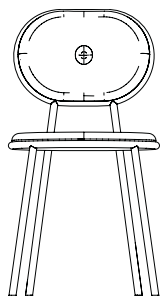

h h A h  
81 51 44 46

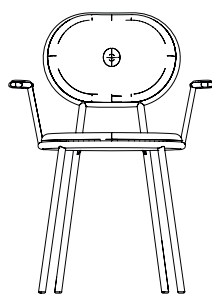

h h A h  
81 51 68 46

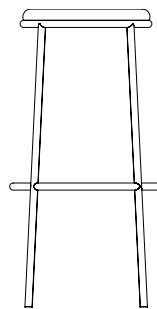

h h A h  
80 41 41 80

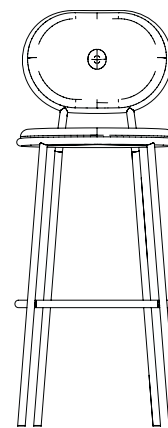

h h A h  
111 50 43 80

**OLYN** OLYN HAS A VERY DISTINCTIVE LOOK. THE CHAIR IS UNIQUE BECAUSE THE METAL FRAME EMBRACES THE SEAT AND BACKREST OF THIS COMPACT AND CHARACTERFUL DESIGN.





**NORWE** THE NORWE IS CHARACTERIZED BY ITS MINIMALIST LOOK, WITHOUT COMPROMISING ON SEATING COMFORT. THE FRIENDLY ROUND SHAPES AND TRANSPARENT BACK MAKE THE NORWE APPLICABLE IN EVERY INTERIOR.



NORWE SC



NORWE AC



NORWE HS

## NORWE FAMILY

Norwe is exclusively designed for Satelliet Originals by the Dutch product and furniture designer Jan Dijkstra. The Norwe has a steel frame with a wooden seat or upholstered seat of choice. The back of the chair is made of mesh. The Norwe series is stackable.

### MATERIALS

frame	metal, steel
frame finishing	powder coated
seat	rubberwood / upholstered, flat
back	metal, wire steel

### EXTRA

stackable	yes
outdoor	no

### COLOURS

frame	matt black
seat / back	rubberwood / fabric or leather, Satelliet collection or supplier

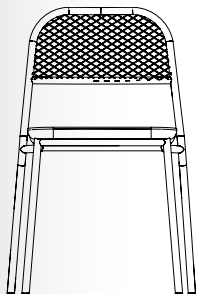

h h A h  
79 55 52 47

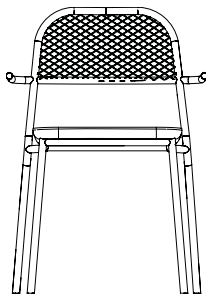

h h A h  
79 55 55 47

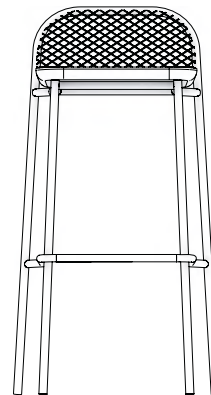
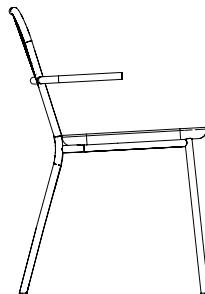

h h A h  
95 50 50 79

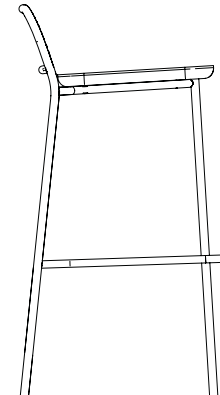







**A chair is one of the  
hardest things, but  
also one of the most  
beautiful things  
to design.**

Lars Snellaars

**Be an original.**

Lars Snellaars

Lars Snellaars graduated from the Design Academy in Eindhoven in 2006 and has been working in his own design studio ever since. For him the most beautiful product to design is a chair. He calls it pure architecture. To Lars a chair is much more than a tool. A chair is defined by its vision, form and functionality, with the individual in his environment as its focal point.

**DESIGNED FOR SATELLIET ORIGINALS**

- ReUnited
- Circl

**ABOUT**



Scan the QR code for  
more information.



**REUNITED** THE REUNITED, A ROARING TWENTIES CHAIR. A TYPICAL SNELLAARS DESIGN: WITH A CLEAR STORY AND FUNCTIONAL DESIGN. THE REUNITED CHAIR REFERS TO THAT LIVELY PERIOD A CENTURY AGO. THAT MEANS NO RIGID, ANGULAR SHAPES BUT RATHER SOFT AND ROUND. THE REUNITED REFLECTS THE SOCIETY WE LIVE IN TODAY.



REUNITED SC



REUNITED HS



## REUNITED

The design stands out with its Art Deco style and a cross in the backrest. The expressive chair can be provided in gold and silver in combination with different colours. The upholstery is nice and soft. The fringes are like the nonsense of life: you don't need them, but they make everything more fun.

### MATERIALS

frame	metal, steel
frame finishing	powder coated
seat / back	upholstered, full

### EXTRA

stackable	no
outdoor	no
CMHR foam	yes

### STANDARD COLOURS

**FRAME** RAL 1005 honey yellow, RAL 1036 pearl gold, RAL 3004 purple red, RAL 3012 beige red, RAL 5003 sapphire blue, RAL 5020 oceanblue, RAL 6011 reseda green, RAL 7016 anthracite grey, RAL 7021 black grey, RAL 7042 traffic grey a, RAL 9005 jet black, RAL 9010 pure white, NCS 2005-B80G misty grey, NCS 4050-Y60R russet orange, NCS 5020-R80B koi blue, NCS 7010-G10Y hunter green, PO57 Brass optic

**SEAT / BACK** fabric or leather, Satelliet collection or supplier

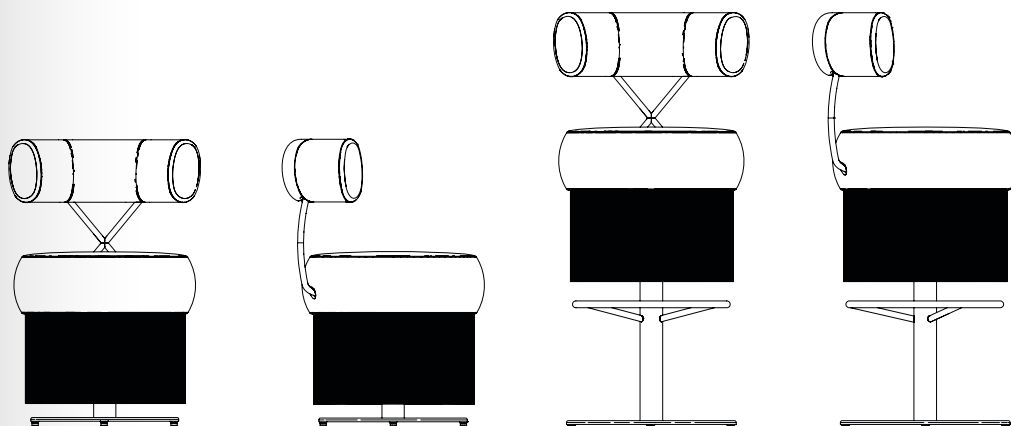

h h A h  
82 60 59 46

h h A h  
103 60 46 80



# Be an original.

## Storytelling with a frivolous touch.

REUNITED - LARS SNELLAARS





CIRCL AC



CIRCL HS



CIRCL 04 HS

## CIRCL FAMILY

The Circl collection was designed exclusively for Satelliet Originals by designer Lars Snellaars. The collection has a steel frame that can be finished in various RAL colours. The seat shell is fully upholstered with a fabric or leather of choice and comes standard with fire-retardant foam (CMHR).

### MATERIALS

frame	metal, steel
frame finishing	powder coated
seat / back	shell, upholstered

### EXTRA

stackable	no
outdoor	no
CMHR foam	yes

### STANDARD COLOURS

**FRAME** RAL 1005 honey yellow, RAL 1036 pearl gold, RAL 3004 purple red, RAL 3012 beige red, RAL 5003 sapphire blue, RAL 5020 oceanblue, RAL 6011 reseda green, RAL 7016 anthracite grey, RAL 7021 black grey, RAL 7042 traffic grey a, RAL 9005 jet black, RAL 9010 pure white, NCS 2005-B80G misty grey, NCS 4050-Y60R russet orange, NCS 5020-R80B koi blue, NCS 7010-G10Y hunter green

**SEAT / BACK** fabric or leather, Satelliet collection or supplier

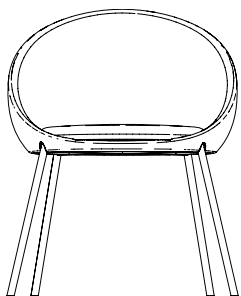

h h A h  
79 59 63 47

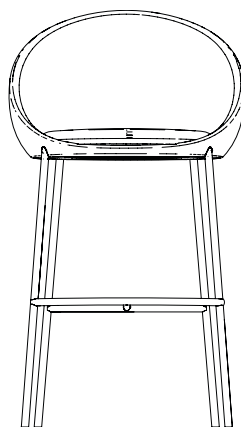
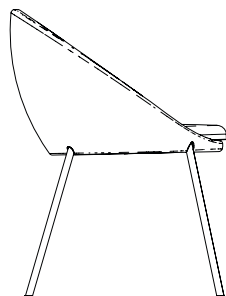

h h A h  
113 68 80 63

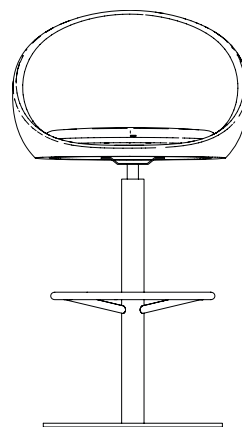

h h A h  
113 68 80 63



**CIRCL** THE DISTINCTIVE ROUND AND CONVEX SHAPES DOES THE NAME CIRCL JUSTICE AND ELEGANTLY DEFINES THE CONTOURS OF THIS DESIGN. THE PREFORMED SHELL IS MADE OF INJECTION FOAM. THE COMBINATION OF SHAPES AND MATERIALS GIVES THIS MODEL A PERFECT SEAT.







A good design should feel like new but at the same time particularly accessible. As if it has always been there.

Jonathan & Babke

Be an original.

HOFMEIJER  
& DEKKER

This designer duo started a studio together in 2011, after graduating from the Design Academy in Eindhoven. Their motto is: 'a design only comes to life when it is used', whether it is products or complete interiors. Jonathan delves into the details, while Babke takes care of the appearance.

#### DESIGNED FOR SATELLIET ORIGINALS

- 25.25
- Steelwood

#### ABOUT



Scan the QR code for more information.

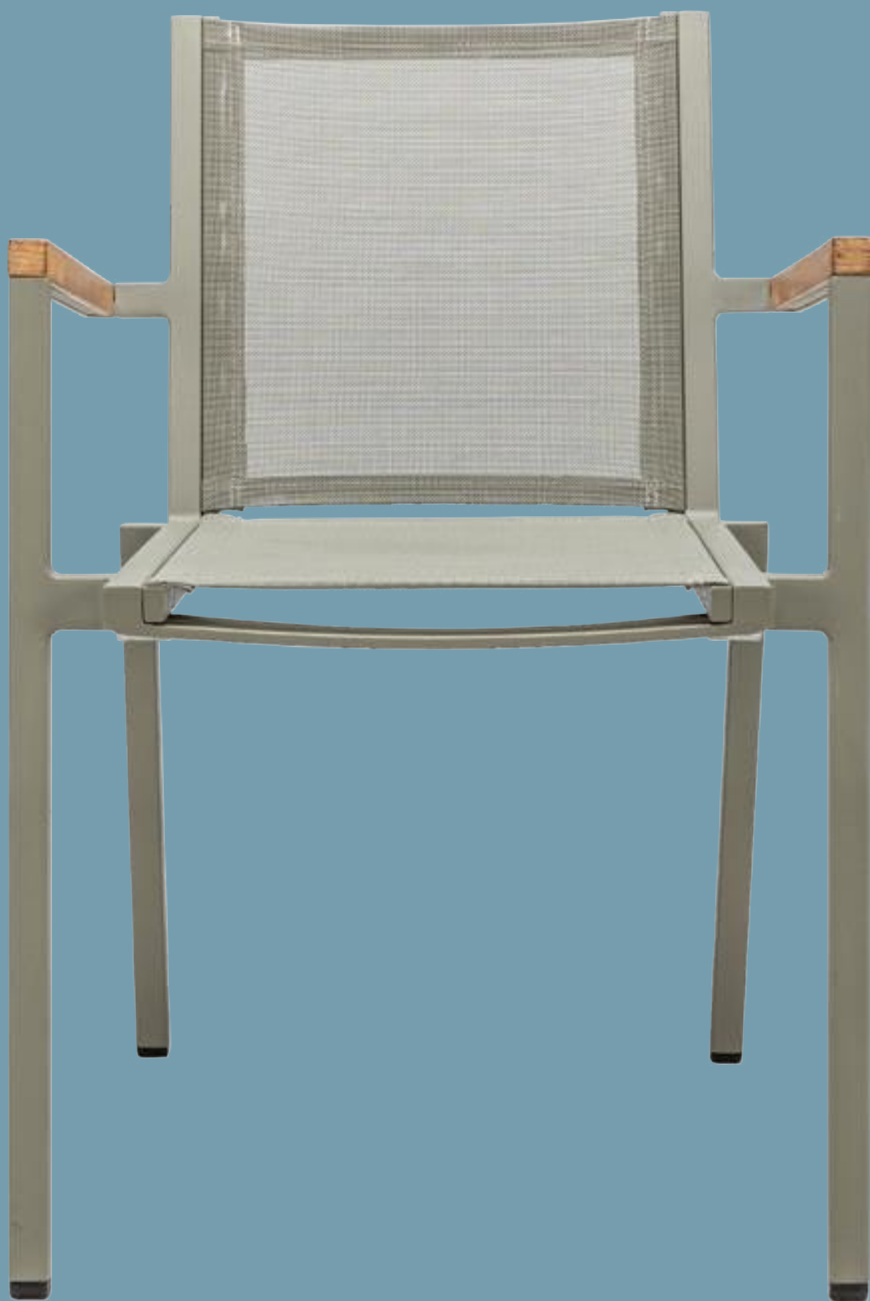

**25.25** THE DESIGNER DUO JONATHAN HOFMEIJER AND BABKE DEKKER ARE RESPONSIBLE FOR A MINIMAL BUT EFFICIENT DESIGN FOR THE 25.25. THE 25.25 IS AN ALL-ROUNDER, STRAIGHTFORWARD AND CAN BE PUT ANYWHERE TO LIGHT UP A ROOM.



25.25 AC



25.25 LAC

## 25.25 FAMILY

The designer duo made a stackable patio chair that has grown into a complete furniture collection: the 25.25 series. Named after the dimensions of the materials used: tubular aluminium profiles of 25 x 25 mm. Armchair 25.25 is stackable and suitable for outdoor use.

### MATERIALS

frame	metal, aluminium
frame finishing	powder coated
seat / back	batyline, upholstered, teak
armrests	teak

### EXTRA

stackable	yes
outdoor	yes (except 25.25 LAC)

### COLOURS

frame	black, moss grey, olive green, terra
seat / back	black, moss grey, olive green, terra

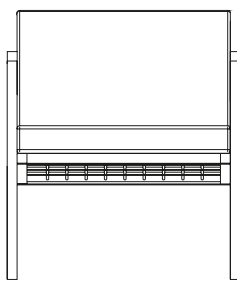
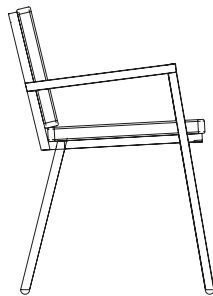
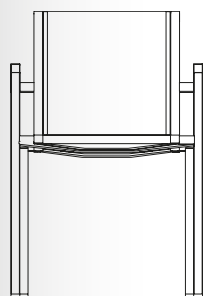

h h A h  
80 60 58 45

h h A h  
63 81 63 39



STEELWOOD SC

STEELWOOD HS

## STEELWOOD

Steelwood has a steel frame and backrest in the colour matte black. The seat is made of rubber wood. The Steelwood series consists of a side chair and stool.

### MATERIALS

frame	metal, steel
frame finishing	powder coated
seat	rubberwood
back	metal, steel

### EXTRA

stackable	no
outdoor	no

### COLOURS

frame	black standard, various RAL colours (request)
-------	---

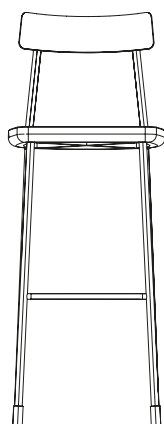
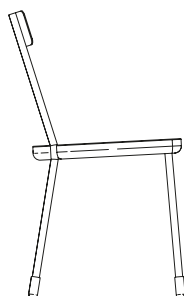
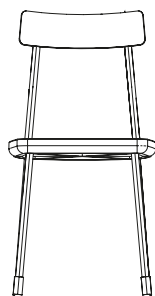

h h A h  
81 51 41 45

h h A h  
110 52 41 80

**STEELWOOD** THE DESIGN OF THE STEELWOOD LOOKS SLEEK AND IS SURPRISINGLY COMFORTABLE. THE 'SOCKS' GIVE IT A CHARACTER OF ITS OWN. STEELWOOD IS EXCLUSIVELY DESIGNED FOR SATELLIET ORIGINALS BY THE DESIGNERS DUO HOFMEIJER AND DEKKER.





The design is a combination of rattan with a metal tubular frame. Apparently simple but on closer inspection extremely complicated.

Be an original.

DIRK VAN SLIEDREGT

We knew Dirk van Sliedregt (1920-2010) as a furniture designer, interior architect and teacher. He was the first to come up with the combination of rattan seating elements with a tubular steel frame. His impressive work ultimately consists of more than 250 models. Chair 550 for Jonkers Meubelen was registered in 1952 and is now produced under license by Satelliet Originals.

**DESIGNED FOR SATELLIET ORIGINALS**

- 550

**ABOUT**



Scan the QR code for more information.



550 SC



550 AC



550 HS

## 550 FAMILY

The aluminium frame, topped with a high-quality synthetic wicker seats and backrests makes this series also suitable for outdoor use. The seat and back are made of the plastic HDPE. The frame is made of aluminium with a coating.

### MATERIALS

frame	metal, aluminium
frame finishing	powder coated
seat / back	rattan look, HDPE wickerwork

### EXTRA

stackable	no
outdoor	yes

### COLOURS

frame	black
seat / back	black, natural

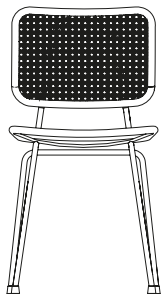

h h A h  
86 51 46 47

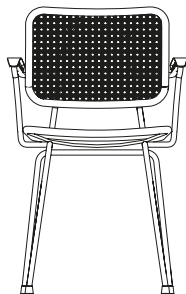

h h A h  
86 51 46 47

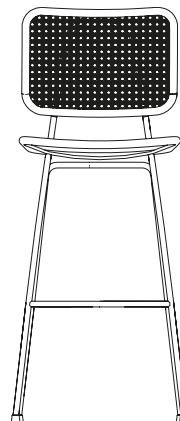
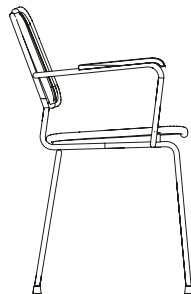

h h A h  
119 51 46 80



**550** CHAIR 550 WAS REGISTERED IN 1952 AND IS NOW PRODUCED UNDER LICENSE BY SATELLIET ORIGINALS. THE 550 SERIES CONSISTS OF A CHAIR, AN ARMCHAIR AND A STOOL.







In our design process  
the applicability for the  
hospitality industry is  
key. It's simply part  
of our DNA.

Chris & Wessel

Be an original.

Chris Montijn and Wessel Storms, both part of the design team that works under the name Studio Satelliet, can be found at Satelliet's production sites with great regularity. There they can closely follow the dynamic process from design to production.

#### DESIGNED FOR SATELLIET ORIGINALS

- |           |             |
|-----------|-------------|
| - Calypso | - Chantilly |
| - Manado  | - Current   |
| - Lux     | - Gerlin    |
| - Canu    | - Code      |

Check out more designs: [satellietoriginals.net](https://satellietoriginals.net)

#### ABOUT



Scan the QR code for  
more information.



**CALYPSO** FINE STRUCTURES, TACTILE TEXTURES WITH A REFERENCE TO NATURE. CALYPSO IS AIRY BUT STURDY, CHEERFUL AND LIGHT. THE POWDER-COATED ALUMINIUM FRAME AND LATTICEWORK GIVE THIS 'GODDESS OF THE SEA' A SUMMERY AND NATURAL LOOK. LIGHTWEIGHT AND WEATHER-RESISTANT.



CALYPSO LOW LAC



CALYPSO HIGH LSC



## CALYPSO FAMILY

Calypso is not only the goddess of the sea, it is also the eye-catcher on any terrace. The powder-coated aluminium frame gives Calypso a cheerful summer look. Calypso is available with a low and high backrest.

### MATERIALS

frame	aluminium, aluminium mesh
frame finishing	powder coated
seat / back	separate seat and back cushion available

### EXTRA

stackable	no
outdoor	yes
CMHR foam	no

### COLOURS

frame	black
seat / back	black

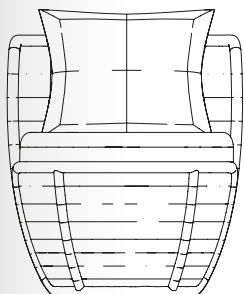

h h A h  
71 63 64 45

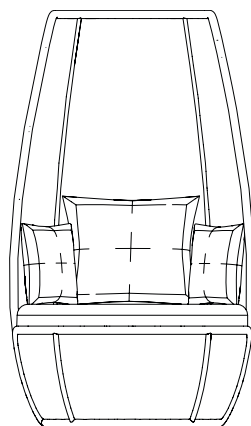
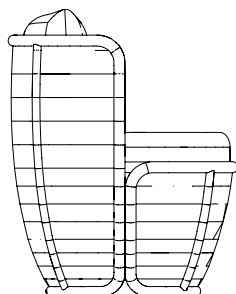

h h A h  
150 88 89 45

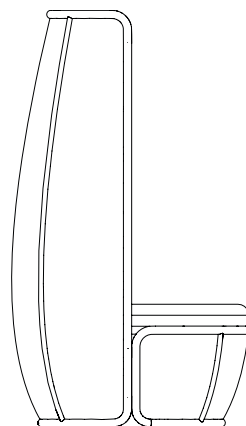



MANADO SC

MANADO SC

MANADO HS

## MANADO FAMILY

The chair has an aluminium frame that comes in the colour black as standard. The seat and back of the Manado are both interwoven with natural cane and give this design the characteristic Thonet look. The seat can be finished in cane or fitted with a flat upholstery with a fabric or leather of your choice. The powder-coated aluminium frame gives it a contemporary touch.

### MATERIALS

frame	metal, aluminium
frame finishing	powder coated
seat	natural cane / upholstered, flat
back	natural cane

### EXTRA

stackable	no
outdoor	no

### COLOURS

frame	black
seat / back	natural cane, fabric or leather, Satelliet collection or supplier

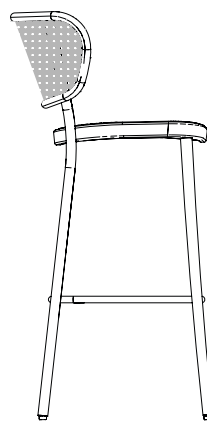
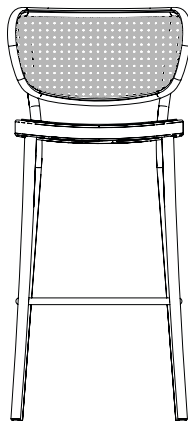
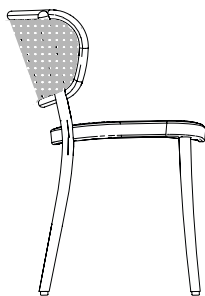
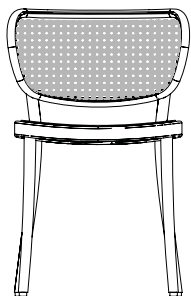

h h A h  
78 54 49 46

h h A h  
111 55 49 80

**MANADO** MANADO IS A DESIGN BY STUDIO SATELLIET. WHEN YOU FIRST LAY EYES ON THE MANADO, IT MAY GIVE YOU HINTS OF A MODERN THONET-CHAIR.





**LUX** THIS LUXURY COLLECTION REALLY INVITES YOU TO TAKE A SEAT AND ENJOY THE COMFORT. THE CHAIRS AND STOOL WERE DESIGNED BY STUDIO SATELLIET AND ARE DISTINGUISHED BY THE FUSION OF THE RECOGNISABLE ROUND AND CONVEX SHAPES.





LUX SC



LUX METAL AC



LUX LAC



LUX HS

## LUX FAMILY

The Lux has the shape of a bullet, the chair is predominantly round. You have options for a wooden or steel frame and an upholstered seat. The lux is optionally available with brass socks.

### MATERIALS

frame	hardwood, beech, metal, steel
frame finishing	lacquered, powder coated
seat / back	upholstered, full

### EXTRA

stackable	no
outdoor	no
CMHR foam	optional
others	brass socks optional

### COLOURS

frame	black
seat / back	fabric or leather, Satelliet collection or supplier

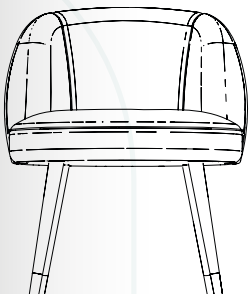

h h A h  
75 66 62 50

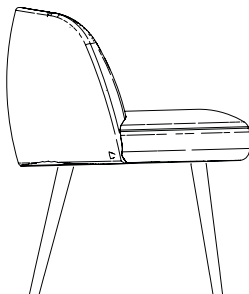

h h A h  
76 65 66 50

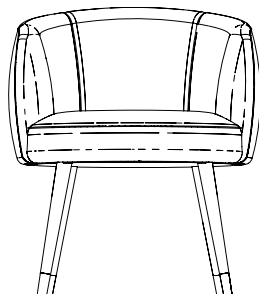

h h A h  
71 70 73 47

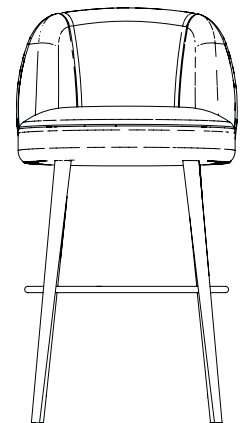
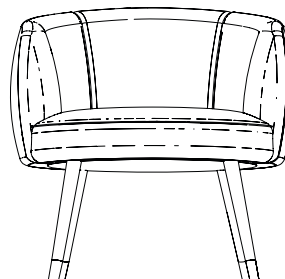

h h A h  
104 64 62 80



CANU SC



CANU SOFT SC



CANU HS



CANU SOFT HS

## CANU FAMILY

The Canu is a design by Studio Satelliet. The chair has round shapes, pretty joints and is solid but slender. The seat is fitted with Danish cord, but can also be upholstered with a fabric or leather of your choice.

### MATERIALS

frame	hardwood, ashwood
frame finishing	lacquered
seat	danish cord, upholstered, leather
back	hardwood, ashwood

### EXTRA

stackable	no
outdoor	no

### COLOURS

frame	walnut, classic walnut, wenge, mahogany, cognac, classic honey, blank, matte blank, carbon, clay
seat / back	danish cord (natural or black) or upholstered, leather

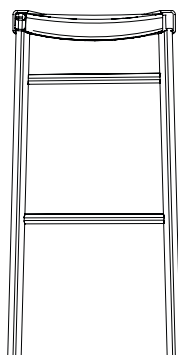
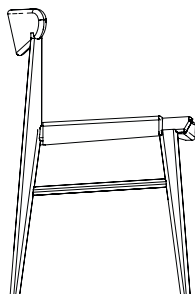
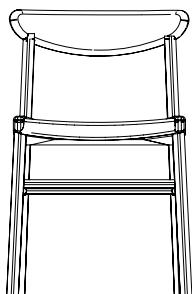

h h A h  
78 50 50 46

h h A h  
82 40 40 82



**CANU** A DESIGN CANNOT LOOK MORE SCANDINAVIAN THAN THE CANU. THIS FOCUS ON NATURE IS REFLECTED IN THE MATERIALS USED: WOOD AND WICKER. IN THE CANU CHAIR SERIES, NATURE INSPIRES CLEAR DESIGN, ORGANIC LINES AND PURE MATERIALS. THE ASHWOOD FRAME COMPLEMENTS THE DESIGN AND FORM THE LANGUAGE OF THE CHAIR.



# Be an original.

## A classic design with a soft touch.

CHANTILLY - STUDIO SATELLIET





**CHANTILLY** THAT A CHAIR MADE OF STEEL CAN ALSO LOOK SOFT AND ROMANTIC IS PROVEN BY THE NEW CHANTILLY. THE GRACEFUL, CLASSIC LINES GIVE THE DESIGN ITS CHARM. ROUND AND RETRO, BUT ALSO SOFT, CUDDLY AND PLAYFUL. WE LOVE THAT RETRO WINK!



CHANTILLY SC



CHANTILLY AC



## CHANTILLY FAMILY

Chantilly is a design by Studio Satelliet. Retro with a wink, and romantic without being overly decorative. Give way to an airy, feminine retro style full of round shapes, soft fabrics and floral designs. A touch fussy, yet cool. That is Chantilly, a chair made of curved steel, a classic design and a soft touch because of the cushion with fringes.

### MATERIALS

frame	stainless, steel
frame finishing	powder coated
seat / back	separate seat and back cushion available

### EXTRA

stackable	yes
outdoor	yes
CMHR foam	no

### COLOURS

frame	white, RAL 1019 grey beige
seat / back	white, RAL 1019 grey beige

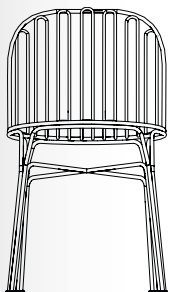

h h A h  
76 58 43 46

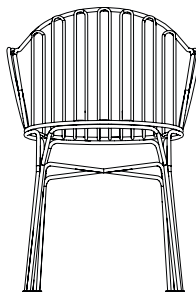
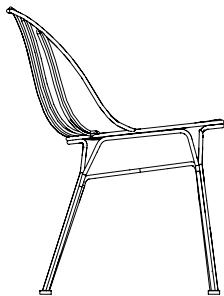

h h A h  
76 58 53 46

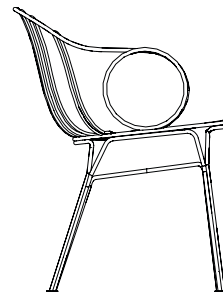



 CURRENT SC



 CURRENT AC



 CURRENT LAC

## CURRENT FAMILY

Current is part of the Satelliet Originals collection and is the first family of products made entirely of recycled materials. Current falls under the initiative SUM - Still Usable Materials. The frames of the various designs are made from recycled aluminium and recycled plastic wickerwork.

### MATERIALS

frame	metal, recycled aluminum
frame finishing	powder coated
seat	upholstered, full, recycled foam
back	recycled HDPE wickerwork

### EXTRA

stackable	no
outdoor	no
others	ring pattern or cane pattern

### COLOURS

frame	black
seat	fabric or leather, Satelliet collection or supplier



still usable materials

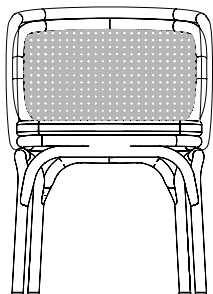

h h A h  
78 58 53 48

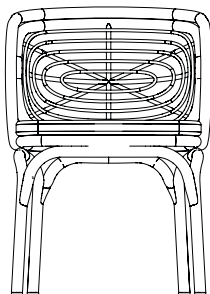

h h A h  
78 58 57 48

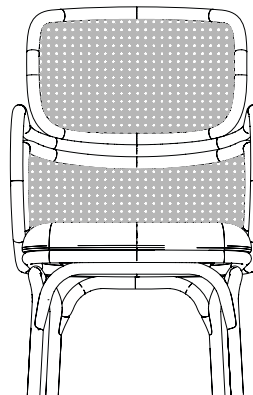
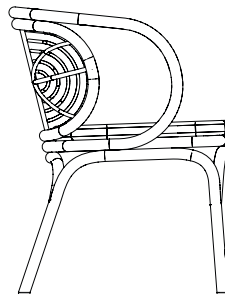

h h A h  
92 78 61 43



**CURRENT** THE CURRENT OWES ITS NAME BECAUSE OF TWO REASONS: THE CURRENT OF THE SEA WHERE MOST MATERIALS COME FROM AND TODAY'S ZEITGEIST. IN A WORLD WHERE SUSTAINABILITY IS THE NEW MANTRA, CURRENT FEELS LIKE THE RIGHT NAME TO SHOW CONTRIBUTION TO THE MATTER.





**GERLIN** THE GERLIN IS EVERYMAN'S FRIEND. THE CHAIR IS  
UTMOST VERSATILE DUE TO ITS SIMPLE DESIGN.  
THEREFORE, THE GERLIN CAN BE PLACED  
ANYWHERE TO ADD COMFORT AND FLAIR TO A  
SPACE. CONICAL COMPACT LEGS AND SLIGHTLY  
CURVED SEAT AND BACK ELEMENTS FORM THE  
BASIS FOR GERLIN'S DESIGN.



GERLIN SC



GERLIN MESH AC



GERLIN LAC



GERLIN MESH HS

## GERLIN FAMILY

Gerlin is a design by Studio Satelliet. The collection leaves a dazzling amount of room for a personal touch in terms of frame finishes and upholstery. You choose how you want your Gerlin: in plywood, steel wire or fully upholstered.

### MATERIALS

frame	metal, steel
frame finishing	powder coated
seat / back	upholstered, full, metal, wire steel, wood, oak plywood
armrests	bakelite

### EXTRA

stackable	no
outdoor	no
CMHR foam	optional

### COLOURS

frame	matt black standard, brass, various RAL colours (on request)
seat / back	fabric or leather, Satelliet collection or supplier

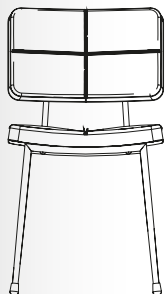

h h A h  
80 50 43 47

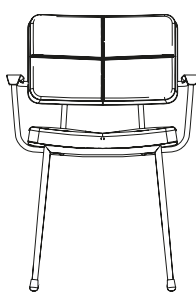
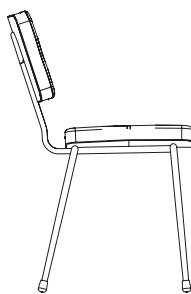

h h A h  
80 50 57 47

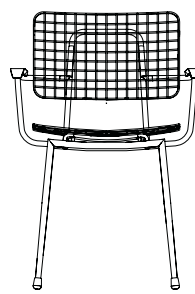

h h A h  
81 51 57 47

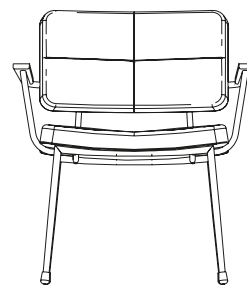

h h A h  
74 65 68 41

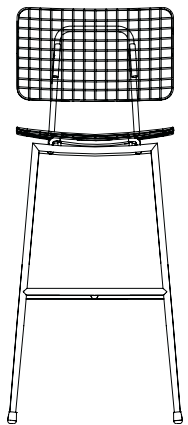

h h A h  
112 53 47 80



 CODE SC



 CODE AC



 CODE HS

## CODE FAMILY

The idea for Code grew out of the previous sustainable models developed by Studio Satelliet. Those who dare to opt for a colourful, cheerful, cool interior will be right with Code. The chair is available in different colours: ocean blue, forest green, desert yellow and galaxy black. The Code series consists of an armchair, chair and barstool.

### MATERIALS

frame	recycled aluminium
frame finishing	powder coated
seat / back	recycled plastic

### EXTRA

stackable	yes
outdoor	no
others	Still Usabe Materials collection

### COLOURS

frame	black, RAL 1024 ochre yellow, RAL 5003 Sapphire blue, NCS S 7010-B70G
seat / back	galaxy black, desert yellow, ocean blue, forest green



still usable materials

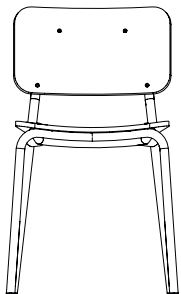

h h A h  
81 53 48 46

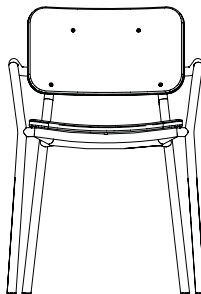
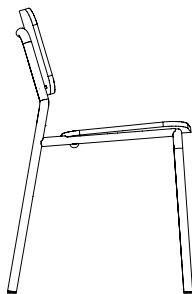

h h A h  
81 53 55 46

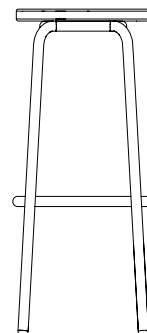
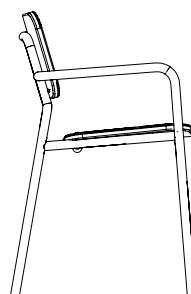

h h A h  
80 45 45 80

**CODE** CODE REPRESENTS THE VALUE OF STILL USABLE MATERIALS. THE FRAME IS MADE OF RECYCLED ALUMINIUM. THE SEAT AND BACK ARE MADE OF RECYCLED PLASTIC AND CONSISTS OF 100% 'POSTCONSUMER WASTE'. THE PLASTICS ARE SORTED BY COLOUR AND THEN REMELTED, CREATING THE CHARACTERISTIC BASE COLOUR WITH CHEERFUL SPECKLES.







Dutch Design classic  
created for Galvanitas  
and redesigned for  
Satelliet Originals with  
respect for its iconic  
'compass legs'.

Be an original.

PAUL  
PHILIPSEN

The Galvanitas S-17 chair has the rightful title of 'style icon'. The design, which is more contemporary than ever, dates back to the 1950s. At that time, the Galvanitas factory faced the huge demand for sturdy and lightweight furniture. Paul Philipssen, one of the designers at Galvanitas, drew the design for the chair with the 'compass leg'.

**DESIGNED FOR SATELLIET ORIGINALS**

- S-17

**ABOUT**



Scan the QR code for  
more information.



**S-17** DESIGNED BY PAUL PHILIPSEN, S-17 IS AN OLD GEM. THE VINTAGE CHAIR IS A REPRODUCTION OF THE CLASSIC GALVANITAS SCHOOL CHAIR FROM THE 1950'S. CHARACTERISTIC FEATURES OF THE MODEL ARE THE STEEL U-PROFILE FRAME, THE COMPASS LEGS AND THE CARBON WOOD SEAT AND BACKREST.





S-17 SC

S-17 AC

S-17 HS

S-17 TB

## S-17 FAMILY

S-17 has a steel frame and a carbon wood seat and back. Even the iconic caps of the chair fit onto the newer versions of the S-17 chairs. The chair is stackable if no upholstery has been applied and also available with armrests. The stool and table complete this special series. The frame, back and seat can be made in different colours. The seat and back can also be upholstered with a fabric of your choice.

### MATERIALS

frame	metal, steel
frame finishing	powder coated
seat / back	carbon wood / upholstered, flat
armrests	carbon wood

### EXTRA

stackable	no
outdoor	no

### COLOURS

frame	black, cement grey, white
seat / back	black, ebony, reddish brown, white / fabric or leather, Satelliet collection or supplier

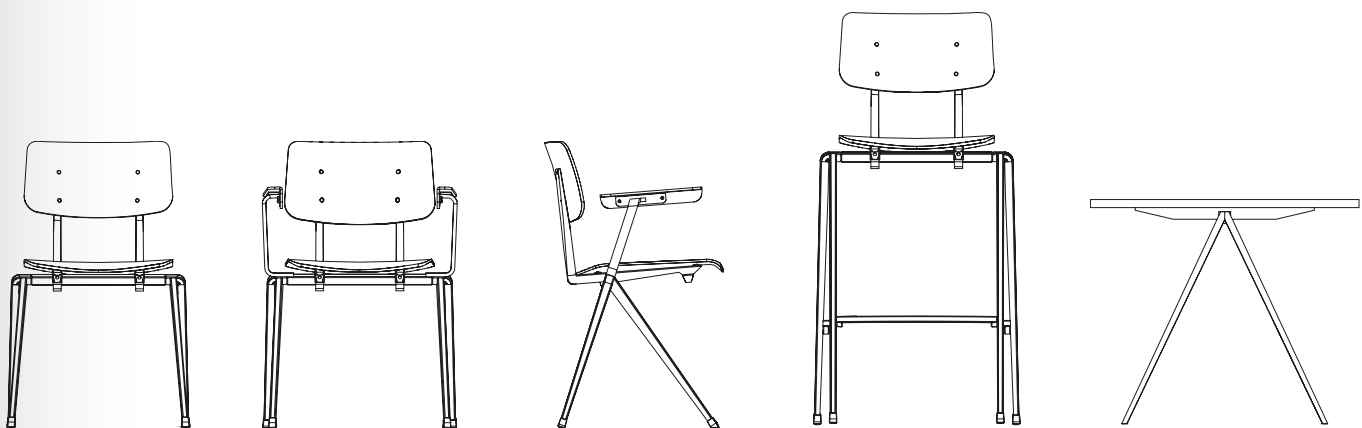

h h A h  
80 50 54 46

h h A h  
82 62 56 46

h h A h  
115 62 54 78

□ □ □  
80 - 100 73 120 - 220





**S-17 TB** THIS TABLE BASE IS INSPIRED BY THE 'COMPASS LEGS' OF THE FAMOUS GALVANITAS S-17 CHAIR. THE BASE IS SUPPLIED IN THE COLOUR BLACK AS STANDARD BUT CAN BE PRODUCED IN OTHER COLOURS ON REQUEST.





**My work balances  
between art and design.  
I have a passion for  
the art of making  
something out  
of nothing.**

Diederik Schneemann

**Be an original.**

DIEDERIK SCHNEEMANN

After his study at the AKI Academy for Art & Design in Enschede, Diederik Schneemann started his own studio in Rotterdam. As a designer, in the broadest sense of the word, he designs designer objects and products. He allows himself to be surprised and inspired by the simple things in everyday life.

**DESIGNED FOR SATELLIET ORIGINALS**

- Tube

**ABOUT**



Scan the QR code for  
more information.



TUBE SC



TUBE AC



TUBE HS

## TUBE FAMILY

Tube is exclusively designed for Satelliet Originals by Diederik Schneemann. Tube has a slender steel frame. The seating and back are either made of plywood or can be fully upholstered. The Tube series consists of a chair, an armchair and a stool.

### MATERIALS

frame	metal, steel
frame finishing	powder coated
seat / back	upholstered, flat
armrests	upholstered

### EXTRA

stackable	no
outdoor	no
CMHR foam	yes

### STANDARD COLOURS

**FRAME** RAL 1005 honey yellow, RAL 1036 pearl gold, RAL 3004 purple red, RAL 3012 beige red, RAL 5003 sapphire blue, RAL 5020 oceanblue, RAL 6011 reseda green, RAL 7016 anthracite grey, RAL 7021 black grey, RAL 7042 traffic grey a, RAL 9005 jet black, RAL 9010 pure white, NCS 2005-B80G misty grey, NCS 4050-Y60R russet orange, NCS 5020-R80B koi blue, NCS 7010-G10Y hunter green

**SEAT / BACK** fabric or leather, Satelliet collection or supplier

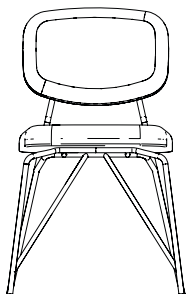

h h A h  
80 53 50 47

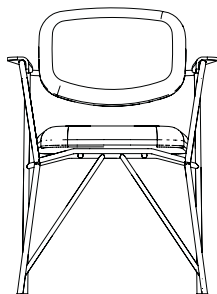

h h A h  
80 53 53 47

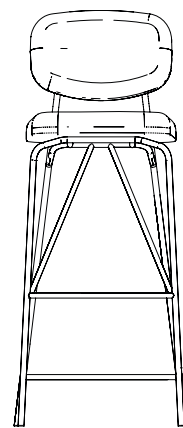
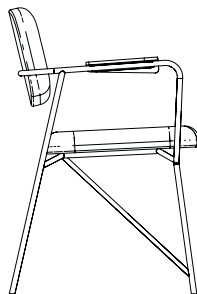

h h A h  
106 49 44 80

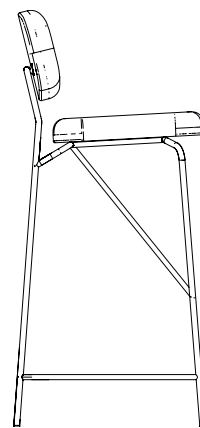

**TUBE** THE INTERPLAY OF LINES FORMED BY THE TUBULAR FRAME MAKES THE CHAIR A STAND-OUT. THE DESIGN EXPLORES THE TENSION BETWEEN STRAIGHT LINES AND ROUNDED FORMS. THE CONNECTION BETWEEN THE BACKREST AND THE FRAME IS A PARTICULARLY AESTHETIC DETAIL.









Design is meant to  
be consumed, so it  
has to be tasty.

Stijn & Victor

Be an original.

BURO NOW

Stijn van Woerkom, graduated designer at Design Academy Eindhoven, designed interiors for shops, restaurants and houses. Since the summer of 2019, they have joined forces in BURO NOW. Stijn and Victor are not guided by conventionalism and make their own plans. 'Design is meant to be consumed, so it has to be tasty.'

**DESIGNED FOR SATELLIET ORIGINALS**

- Biscuit

**ABOUT**



Scan the QR code for  
more information.



BISCUIT SC



BISCUIT LSC



BISCUIT MS



BISCUIT HS

## BISCUIT FAMILY

The Biscuit series is exclusively designed for Satelliet Originals by the Dutch designers of BURO NOW. Biscuit has a steel frame that can be executed in various RAL colours. The back and seat are upholstered in a fabric or leather of your choice from our house-collection and standardly come with fire retardant foam (CMHR).

### MATERIALS

frame	metal, steel
frame finishing	powder coated
seat / back	upholstered, full

### EXTRA

stackable	no
outdoor	no
CMHR foam	yes

### STANDARD COLOURS

**FRAME** RAL 1005 honey yellow, RAL 1036 pearl gold, RAL 3004 purple red, RAL 3012 beige red, RAL 5003 sapphire blue, RAL 5020 oceanblue, RAL 6011 reseda green, RAL 7016 anthracite grey, RAL 7021 black grey, RAL 7042 traffic grey a, RAL 9005 jet black, RAL 9010 pure white, NCS 2005-B80G misty grey, NCS 4050-Y60R russet orange, NCS 5020-R80B koi blue, NCS 7010-G10Y hunter green

**SEAT / BACK** fabric or leather, Satelliet collection or supplier

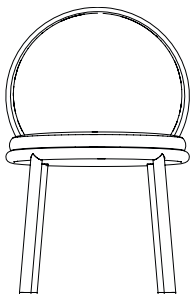

h h A h  
80 57 52 46

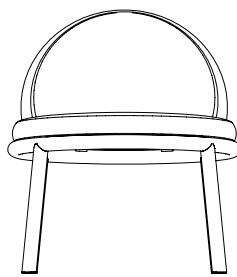
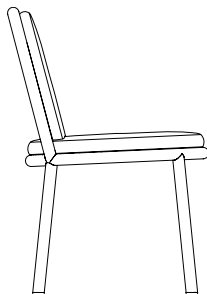

h h A h  
70 65 59 43

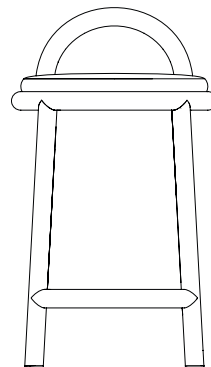

h h A h  
73 45 43 60

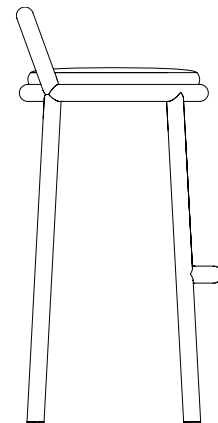

h h A h  
93 46 39 80



**BISCUIT** CRAVING SOMETHING SWEET AND LIGHT? THE BISCUIT SATISFIES THAT NEED WITH ITS SEAT AND BACK THAT LOOK LIKE A COOKIE. THE CHAIR HAS A STURDY LOOK DUE TO THE THICK STEEL FRAME. IT IS A FUN, STURDY CHAIR WITH A JOYOUS LOOK AND FEEL.



# Be an original.

## Design needs to be tasteful.

BISCUIT - BURO NOW







Our goal is to turn every design into a sensual experience. Smart functional products, where the character reinforces the brand identity.

Jon & Sven

Be an original.

JON+SVEN

Jon+Sven is a Dutch designer duo formed by Jon Assink and Sven Schimmer. Their goal is to turn every design into a sensual experience. Smart functional products, where the character reinforces the brand identity. In recent years Jon and Sven have built up a broad portfolio, in which well-known Dutch and international brands are represented. Their style: friendly yet business-like, and soft with a surprisingly sharp edge.

#### DESIGNED FOR SATELLIET ORIGINALS

- Oso

#### ABOUT



Scan the QR code for more information.



**OSO** AN EYECATCHER IN EVERY SPACE. OSO HAS A DARING APPEARANCE AND STANDS FIRMLY ON ITS THICK WOODEN FEET. THE OSO IS PART OF A SERIES OF SOFAS THAT ARE AVAILABLE IN BOTH DINING AND LOUNGE HEIGHT.





OSO AC



OSO B

## OSO FAMILY

The Oso series is exclusively designed for Satelliet Originals by the Dutch designers Jon+Sven. The playful shapes make this design a favourite in many interiors. The wooden frame with foam construction provides a robust base with soft seating.

### MATERIALS

frame	wood, oak
frame finishing	lacquered
seat / back	upholstered, full

### EXTRA

stackable	no
outdoor	no

### COLOURS

frame	walnut, classic walnut, wenge, mahogany, cognac, classic honey, blank, matte blank, carbon, clay
seat / back	fabric or leather, Satelliet collection or supplier

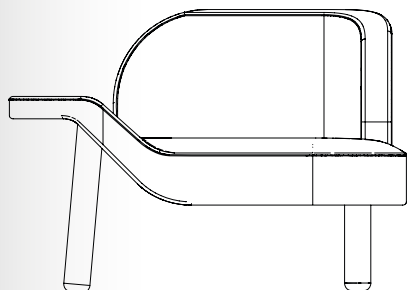

h h A h  
75 80 100 40

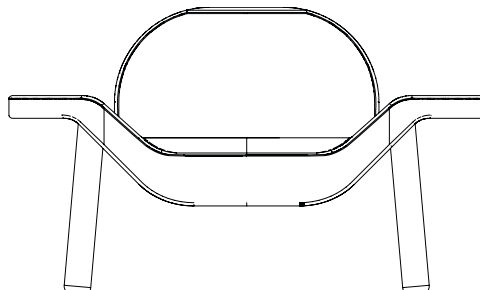

h h A h  
75 80 120 40

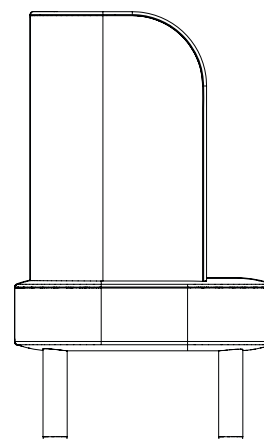

h h A h  
160 80 -- 40





I'm inspired by  
different shapes  
and forms around  
me and that  
influences my  
designs.

Frans Schrofer

Be an original.

FRANS  
SCHROFER

Born into a family of artists and designers, Frans Schrofer graduated from the Design Academy in Eindhoven in 1983 and started his own studio in The Hague a few years later. Studio Schrofer is known for its recognisable world of shapes and has won various international design awards for innovation, technology and sustainability. Schrofer's 'hands-on design' guarantees ergonomically comfortable designs that are also visually appealing.

#### DESIGNED FOR SATELLIET ORIGINALS

- Mistral
- Loop
- Orbit
- Gelato

#### ABOUT



Scan the QR code for  
more information.



**MISTRAL** A TRENDY CHAIR WHICH CAN BE CATEGORIZED AS 'NEW INDUSTRIAL'. THE CHAIR IS AVAILABLE IN TWO VARIANTS. THE MISTRAL EXUDES COMFORT AND HAS A CASUAL LOOK AND FEEL.



MISTRAL AC

## MISTRAL

The Mistral series is exclusively designed for Satelliet Originals by designer Frans Schrofer. The practical steel frame and a tub of wire steel has an upholstered cover. The characteristic design of the cover makes the Mistral look casual and sleek.

### MATERIALS

frame	metal, steel
frame finishing	powder coated
seat / back	shell, wire steel, standard cushion
armrests	metal, wire steel, standard cushion

### EXTRA

stackable	no
outdoor	no
CMHR foam	optional
others	seat and back cushion included

### COLOURS

frame	black
seat	fabric or leather, Satelliet collection or supplier

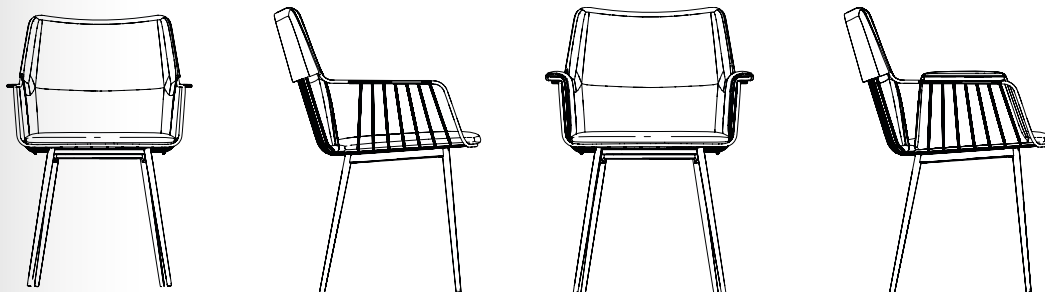

h h A h  
84 60 58 48

h h A h  
84 60 58 47



# Be an original.

## A futuristic and playful look.

LOOP - FRANS SCHROFER





LOOP HS

## LOOP

The Loop, designed by Frans Schrofer, has a steel frame with an upholstered seat and back. The stool is rotatable, making it widely applicable in various hospitality settings.

The characteristic steel frame can be customised and coated in various RAL colours. This freedom also applies to the extensive choice of back and seat upholstery.

### MATERIALS

frame	metal, steel
frame finishing	powder coated
seat / back	upholstered, full

### EXTRA

stackable	no
outdoor	no
CMHR foam	yes

### STANDARD COLOURS

**FRAME** RAL 1005 honey yellow, RAL 1036 pearl gold, RAL 3004 purple red, RAL 3012 beige red, RAL 5003 sapphire blue, RAL 5020 ocean blue, RAL 6011 reseda green, RAL 7016 anthracite grey, RAL 7021 black grey, RAL 7042 traffic grey a, RAL 9005 jet black, RAL 9010 pure white, NCS 2005-B80G misty grey, NCS 4050-Y60R russet orange, NCS 5020-R80B koi blue, NCS 7010-G10Y hunter green

**SEAT / BACK** fabric or leather, Satelliet collection or supplier

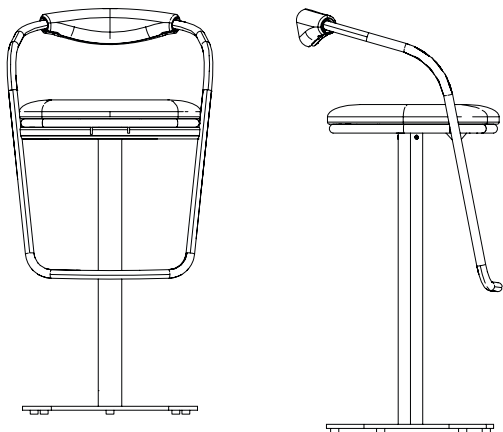

h	h	A	h
104	50	52	80





**LOOP** HOW DO YOU MAKE A STEEL FRAME SPECIAL? DESIGNER FRANS SCHROFER KNEW HOW. THE LINES OF THE FRAME CONTINUE FROM THE BACK INTO A FOOTREST, GIVING THE STOOL A FUTURISTIC AND PLAYFUL LOOK. THE FOOTPLATE FOLLOWS THE SHAPE OF THE SEAT. THE SWIVEL STOOL HAS A SMALL UPHOLSTERED BACK AND SEAT.



**ORBIT** THIS REMARKABLE DESIGN BY FRANS SCHROFER TAKES YOU INTO ORBIT. THE ROUND SHAPE OF THE SEAT AND BACK ARE EMPHASISED BY THE STRIKING FRAME THAT SEEMS TO FLOAT AROUND THE CHAIR.



ORBIT SC



ORBIT AC

# ORBIT

Orbit has been designed exclusively for Satelliet Originals by Frans Schrofer. The frame is striking and, together with the round shape of the seat and back, creates the unique character of this functional chair. The frame can be finished in different colours.

### MATERIALS

frame	metal, steel
frame finishing	powder coated
seat / back	shell and back upholstered
armrests	upholstered

### EXTRA

stackable	no
outdoor	no
CMHR foam	optional

### STANDARD COLOURS

**FRAME** RAL 1005 honey yellow, RAL 1036 pearl gold, RAL 3004 purple red, RAL 3012 beige red, RAL 5003 sapphire blue, RAL 5020 ocean blue, RAL 6011 reseda green, RAL 7016 anthracite grey, RAL 7021 black grey, RAL 7042 traffic grey a, RAL 9005 jet black, RAL 9010 pure white, NCS 2005-B80G misty grey, NCS 4050-Y60R russet orange, NCS 5020-R80B koi blue, NCS 7010-G10Y hunter green

**SEAT / BACK** fabric or leather, Satelliet collection or supplier

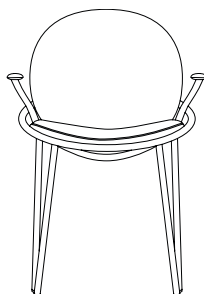
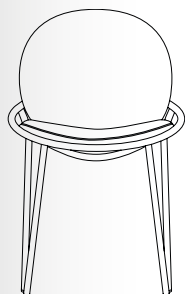

h h A h  
84 62 53 48

h h A h  
84 62 61 48



GELATO SC



GELATO AC



GELATO LAC



GELATO HS

## GELATO FAMILY

The Gelato series is exclusively designed for Satelliet Originals by designer Frans Schrofer. The collection has a steel frame that comes standard in the colour black. On request, the frame can also be coated in other RAL colours. The seat shell is fully upholstered with a fabric or leather of your choice and standardly comes with fire-retardant foam (CMHR).

### MATERIALS

frame	metal, steel
frame finishing	powder coated
seat / back	shell, upholstered, flat

### EXTRA

stackable	no
outdoor	no
CMHR foam	yes

### COLOURS

frame	black standard, various RAL colours (on request)
seat / back	fabric or leather, Satelliet collection or supplier

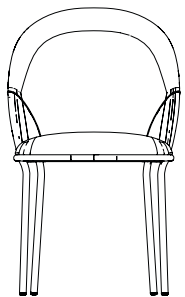

h h A h  
80 53 53 47

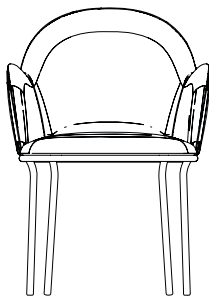
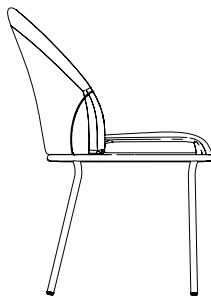

h h A h  
116 53 52 80

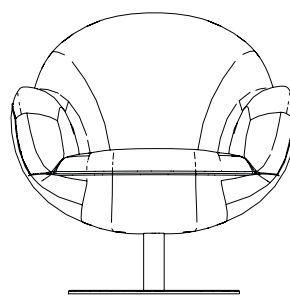

h h A h  
86 73 84 43

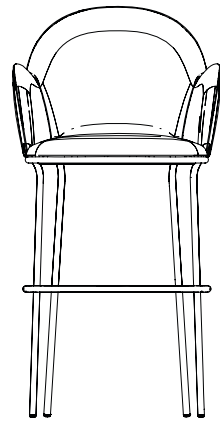

h h A h  
116 53 52 80

**GELATO** THE NAME GELATO IS THE ITALIAN WORD FOR ICE CREAM. THE SHAPE OF THE CHAIR, STACKED SCOOPS OF ICE CREAM, NOT ONLY GIVES GELATO AN INVITING LOOK, BUT ALSO FACILITATES THE ARMRESTS IN THE DESIGN.







The design itself  
is the core,  
its implementation  
or realisation  
is an option,  
not a 'must'.

Dave Keune

Be an original.

DAVE KEUNE

Dave Keune enjoys working on various projects in his own studio. It is characteristic of his work that the design itself is the core. The execution or realization of his products are in his opinion an option, not a 'must'. The design of Dave Keune targets both aesthetic as functional values. While developing his design, either products or environments, Keune operates through layers of research, development and production.

#### DESIGNED FOR SATELLIET ORIGINALS

- Brewer
- Forge

#### ABOUT



Scan the QR code for  
more information.



**BREWER** BREWER HAS AN INDUSTRIAL ORIGIN AND ENCOURAGES A COSY MEET & GREET. THE MODERN TABLE IS A PERFECT FIT IN EVERY HOSPITALITY INTERIOR.





BREWER T

## BREWER

Brewer is a table made of solid oak wood that can be finished in the colours walnut, classic walnut, carbon, clay, wengé, cherry, mahogany, cognac, classic honey, white and matte white.

The table is also available in natural or bleached ash wood.

Brewer is available in five dimensions (table top): 200 x 100 cm, 225 x 100 cm, 250 x 100 cm, 275 x 100 cm and 300 x 100 cm.

The footrest has a black coating.

### MATERIALS

frame	wood, solid oak, ash wood
frame finishing	lacquered
table top	wood, solid oak, ash wood

### EXTRA

stackable	no
outdoor	no
others	metal, steel footrest

### COLOURS

frame / table top	walnut, classic walnut, wenge, mahogany, cognac, classic honey, blank, matte blank, carbon, clay
-------------------	--

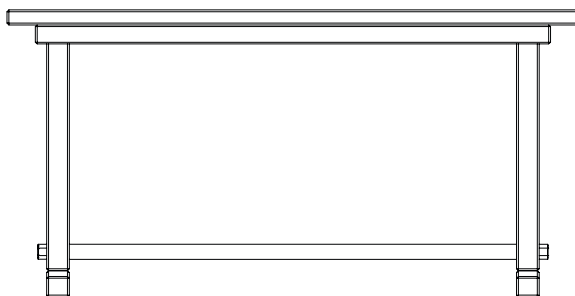
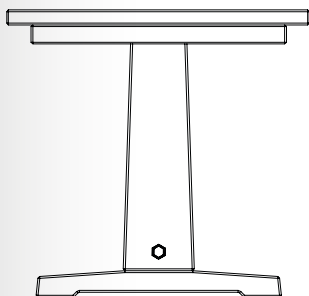

100



76



200 - 300



FORGE T

## FORGE

Forge is a table made of solid oak wood that can be finished in the colours walnut, classic walnut, carbon, clay, wengé, cherry, mahogany, cognac, classic honey, white and matte white. The table is also available in natural or bleached ash wood.

Forge is available in six dimensions (table top): 200 x 80 cm, 200 x 100 cm, 225 x 100 cm, 250 x 100 cm, 275 x 100 cm and 300 x 100 cm. The footrest has a black coating.

### MATERIALS

frame	wood, solid oak, ash wood
frame finishing	lacquered
table top	wood, solid oak, ash wood

### EXTRA

stackable	no
outdoor	no
others	metal, steel footrest

### COLOURS

frame / table top	walnut, classic walnut, wenge, mahogany, cognac, classic honey, blank, matte blank, carbon, clay
-------------------	--

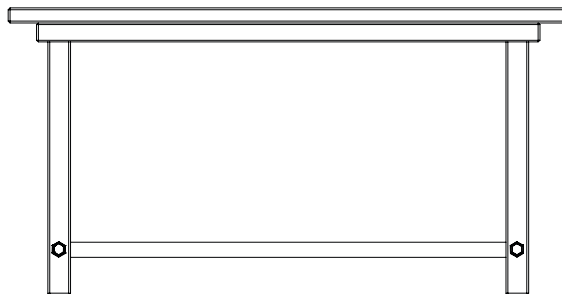
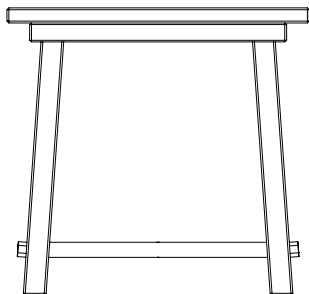

80 - 100    76    200 - 300

**FORGE** THE DESIGN OF THE FORGE TABLE FOCUSES ON BOTH AESTHETIC AND FUNCTIONAL VALUES. THE STURDY TABLE IS EXPERTLY CRAFTED AND STRIVES FOR HIGH USABILITY AND DURABILITY. THE ROBUST TABLE HAS A MODERN TWIST THANKS TO THE BLACK FOOTREST.







The art of design  
is to keep thinking  
very purely. Trying to  
maintain the simple,  
pure form.

Gerard van den Berg

Be an original.

GERARD  
VAN DEN BERG

Although Gerard van den Berg grew up in the furniture company as the son of a furniture manufacturer, he first developed his artistic talents when he was trained as a painter. Later he studied furniture manufacturing at the MTS in Rotterdam and started working as a designer in his father's company. According to Van den Berg, the art of design is to keep thinking very purely. He tries to maintain the simple, pure form from the first sketch to the final production.

**DESIGNED FOR SATELLIET ORIGINALS**

- Montana

**ABOUT**



Scan the QR code for  
more information.



**MONTANA** ACCORDING TO VAN DEN BERG, THE ART OF DESIGN IS TO KEEP THINKING VERY PURELY. HE TRIES TO MAINTAIN THE SIMPLE, PURE FORM FROM THE FIRST SKETCH TO THE FINAL PRODUCTION. MONTANA IS PURE, NONCHALANT AND LOOSE.



MONTANA COVER AC



MONTANA CUSHION AC

## MONTANA

Van den Berg's signature, the metal framework with a baggy loose cover, make for an extremely comfortable casual looking chair. The Montana is stackable and suitable for outdoor use. The cushions are available in different fabrics.

### MATERIALS

frame	metal, steel
frame finishing	powder coated
seat / back	textilene, full cover, cushion
armrests	textilene, full cover

### EXTRA

stackable	yes
outdoor	yes
others	seat cushion included

### COLOURS

frame	black
seat	fabric, Satelliet collection or supplier

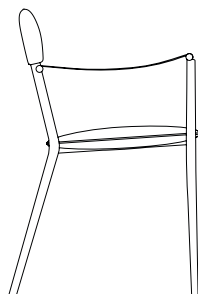
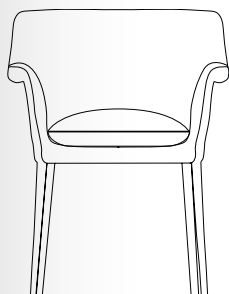

h h A h  
80 51 58 46

h h A h  
80 51 58 46





”

**Every product is the result of a creative thinking process with one common dominator: bringing people together.**

Ardie van Bommel

**Be an original.**

Ardie van Bommel graduated from the Design Academy Eindhoven in 2010. From her design studio BOMM she designs and develops new products and concepts defining private and public spaces. Each final product is the result of an enthusiastic, creative thought process with one common denominator: bringing people together. As a designer, Ardie is very involved: from the design phase to realization. She also likes to work together with other inspiring professionals, because she believes that in this way no challenge is too big.

**DESIGNED FOR SATELLIET ORIGINALS**

- Ear

**ABOUT**



Scan the QR code for more information.



**EAR** INTENDED AS A MODEL WHERE YOU CAN SIT TO SHUT YOURSELF OFF FOR A WHILE. THE EAR INVITES YOU TO YOUR ME-TIME, TO READ OR WORK. THIS GIGANTIC EYECATCHER EMBRACES YOU WITH THE LARGE FLAP IN THE FRONT. THIS CHAIR WAS EXCLUSIVELY DESIGNED FOR SATELLIET ORIGINALS BY THE DUTCH DESIGNER ARDIE VAN BOMMEL.



EAR AC

## EAR

Ear has an oak frame and table top that can be finished in the colours walnut, classic walnut, wengé, cherry, mahogany, cognac, classic honey, blank and matte blank. The chair is fully upholstered with a fabric of your choice. The chair comes with an adjustable table top (25 mm thick) made of solid oak and a loose back cushion (45 x 45 cm).

### MATERIALS

frame	wood, oak
frame finishing	lacquered
seat / back	shell, upholstered, flat

### EXTRA

stackable	no
outdoor	no
others	loose back cushion

### COLOURS

frame	walnut, classic walnut, wenge, mahogany, cognac, classic honey, blank, matte blank, carbon, clay
seat / back	fabric or leather, Satelliet collection or supplier

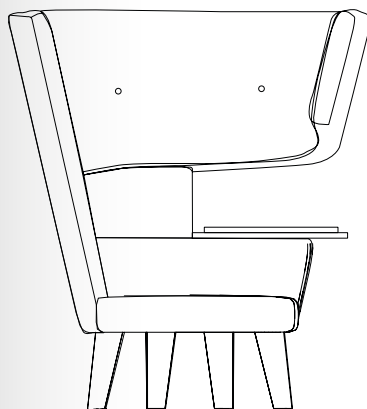

h h A h  
162 150 123 47





I want to experience every facet of the design first. That's why I always build my prototypes myself.

Tom Frencken

Be an original.

TOM  
FRENCKEN

Tom Frencken studied Interior Architecture and Furniture Design at the KHM in Mechelen. Since 2007 he has been working from his own studio on free work and assignments. Frencken makes timeless high quality furniture that should last for several generations. In addition, his designs often have an idiosyncratic appearance.

**DESIGNED FOR SATELLIET ORIGINALS**

- Legs

**ABOUT**



Scan the QR code for more information.



**LEGS** DESIGNS BY TOM FRENCKEN OFTEN HAVE A CARTOONISH LOOKING TWIST. IN THIS DESIGN, THE CLEAR SHAPES AND ROUNDED LINES GIVE THE TABLE A DISTINCTIVE CHARACTER.



LEGS T

## LEGS

This table is exclusively designed by Tom Frencken for the Satelliet Originals collection. The Table is available in a solid beech, a standard oak and an aged oak version. The table can be stained in various colours.

### MATERIALS

frame	wood, solid oak, aged oak, beech
frame finishing	lacquered
table top	wood, solid oak, aged oak, beech

### EXTRA

stackable	no
outdoor	no
others	metal, steel footrest

### COLOURS

frame / table top	walnut, classic walnut, wenge, mahogany, cognac, classic honey, blank, matte blank, carbon, clay
-------------------	--

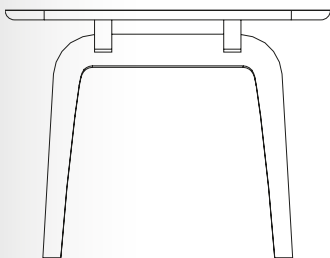

80 - 100	76	120 - 300







# Be an



All shown pictures can deviate from reality. Variations possible to actual finish and sizes.  
Misprints or printing errors with reservation.

This magazine contains a selection of the Satelliet Originals collection. Discover all the possibilities at [www.satellietoriginals.net](http://www.satellietoriginals.net)



**original.**

**Be an original.**

---

**SATELLIET**<sup>®</sup>  
ORIGINALS

---

[satellietoriginals.net](http://satellietoriginals.net)