

**Surge Protective Devices**  
Product Catalog





# TABLE OF CONTENTS

PQ GLOBAL · Surge Protective Devices Product Catalog · 2026

Surge Suppression Devices Explained	4
Product Family	6
<b>T42</b> T42 Non-Modular Surge Protective Device 50kA per Phase	8
<b>T45</b> T45 Non-Modular Surge Protective Device 50kA per Phase	10
<b>T460</b> Tier 460 Over/Under Motor Protection 50kA T45 Series SPD · Contactor and Active Monitoring & Control	13
<b>T470</b> Tier 470 Power Quality System 50kA T45 Series SPD · Contactor, Line Reactor, and Active Monitoring & Control	16
<b>T71</b> T71 Non-Modular Surge Protective Device High Energy Series · 100kA per Phase	19
<b>T45</b> T45 Non-Modular Surge Protective Device 100kA – 300kA per Phase	22
<b>T45</b> T45 Modular Surge Protective Device 100kA – 300kA per Phase	25
<b>T45</b> T45 Modular Surge Protective Device 100kA – 300kA per Phase	26
<b>T45</b> T45 Modular Surge Protective Device 400kA – 600kA per Phase	28
<b>T1</b> T1 2-Pair Dataline Surge Protective Device Modular Pluggable DIN	31
<b>T2</b> T2 AC Noise Filter & Surge Protective Device 50kA per Phase	33
<b>T2-FD</b> T2-FD SLAC – AC Series Surge Filter Data/Signal Line Surge Protection	35
<b>T2L</b> T2 Line Reactor Series	38
<b>T2-45</b> T2-45 Surge Reactor Series Surge Protection and Line Reactor	40
<b>PQGMP</b> Medium Voltage Digital Monitoring Panel	43
<b>T65</b> Medium Voltage Surge Arrester – 1000V or Greater	46
What Electrical System Is It?	48

*YOU CANNOT AVOID TRANSIENTS, BUT YOU CAN PROTECT AGAINST THEM*

Transients are the most destructive power quality problem, causing continuous or permanent damage to your critical equipment and are responsible for 80% of downtime costs.

Fortunately, Surge Protection Devices (SPD) are simple to select, simple to implement, simple to install, and is the lowest cost power quality solution there is.

**UL-1449 and National Electric Code  
285 recommend 3 levels of protection**

- *Service Entrance*  
(Category C or Type 1)
- *Branch Panels*  
(Category B or Type 2)
- *Point of Use*  
(Category A or Type 3)



## SERVICE ENTRANCE:

External transients are generated by lightning, utility switching or nearby facilities.  
Your service entrance can be fully protected with a surge suppressor > 150KA



***The Surge Protection Devices must be installed close to the service entrance.***

## BRANCH PANEL:

65% of all transients are generated inside a building and can damage or reduce the life of expensive critical equipment, stopping important costly processes and causing long term power outages.

Your facility's every day operation is the cause of these transients. (Load switching, motor starts, air conditioners, robotics, chillers, or any equipment that turns on and off)

These branch panel transients cause millions of dollars in equipment damage and production losses.

Branch panel protection recommended is >100KA



***These Surge Protection Devices will protect everything that is connected to the panel.***

## POINT OF USE:

At the point of use, it is important to protect the equipment and processes that are critical to your operation. Such as VFDs, controls, CNCs, AC controls, communication equipment, servers, routers, internet equipment, and Building Management Systems.

Point of use protection recommended is >50KA



***These Surge Protection Devices must be installed close to the critical load***

## IN SUMMARY:

If you know the electrical location (Service Entrance, Branch Panel, or Point of Utilization) and you know the voltage of the panel, you can easily define what protection you need.



## Category A (Type 3)

Point of Use Protection  
50 KA to 100 KA Surge Rating



50 KA



50 KA



50KA (Motor Protection)

## Category B (Type 2)

Branch Panel Protection  
100 KA to 200 KA Surge Rating



100KA



100KA, 150KA, 200KA, 250KA, 300KA

## Category C (Type 1)

Service Entrance Protection  
200 KA to 600 KA Surge Rating



100KA, 150KA, 200KA, 250KA, 300KA



400KA, 500KA, 600KA

## Specialty Products

### AC Series Surge Filter and Data/Signal Line Surge Protection



Dataline SPD



Noise Filter & SPD



SPD, Filter, Data/Signal

## Reactors



Line Reactor Series



Reactor & SPD

## Medium Voltage



Power Meter



MV SPD

## T42 Non-Modular Surge Protective Device 50kA per Phase

### 50kA/phase Model



This is the T42 Non-Modular SPD with a 50kA per Phase surge current capacity. This T42 Non-Modular Surge Protective Device has a 2.3" x 2.5" x 1.6" NEMA 4X rated polycarbonate enclosure and weighs 0.5 pounds. It has a watertight indoor/outdoor rating, a liquid-tight connector, and external mounting flanges. This unit is the perfect fit for applications in which the SPD must fit in a small space or where high-capacity units are not required. These qualities also make this unit especially useful in downstream applications.

The T42 is a single phase unit, available in 120V and 240V configurations; the 120V unit may be used interchangeably in 127V applications. Phase protection is indicated by a single LED. The LED will remain lit to let the user know the unit has power and is in good health. The LED should be lit after installation; an off condition after proper installation will indicate one of the monitored modes experienced a failure.

It is only available as a UL 1449 Type 1 device, which may be placed on the line or load side of a main disconnect. This SPD uses advanced Thermally Protected Metal Oxide Varistors. Its MOVs are of the same high quality and design as all the other SPDs in our surge protection family of units. The T42 carries a 10-year warranty.

This unit has 30" of #12 AWG wire leads.

### General Technical Specifications

Connection Type	Parallel, Wire Lead - #12 AWG
Voltage, Phase Configuration	120V Single Phase, (L1, N, G) 240V Single Phase, (L1, L2, G)
Maximum Continuous Operating Voltage	120V, 150 VAC (125%); 127V, 150 VAC (118%); 240V, 320 VAC (115%)
Surge Capacity	25kA/Mode, 50kA/Phase
Short Circuit Current Rating (SCCR)	200kAIC
Protection Modes	All Modes: L-N, L-G, N-G
Operating Frequency Range	47 - 63 Hz
UL 1449 Location Type	Type 1 ( <i>SPDs intended for Line or Load Side of Main Disconnect</i> ) only
UL 1449 Nominal Discharge Current	10 kA
Standards	UL 1449 4th Edition, CSA, UL 96A Lightning Protection Master Label compliant
Status Indication	LED
Enclosure	NEMA 4X Polycarbonate
Dimensions	2.29" x 2.54" x 1.63" (H x W x D)
Weight	0.50 lbs
50 Ohm EMI/RFI Attenuation	-45db max(Type 1); from 10 kHz to 100MHz. The system provides up to 120dB insertion loss from 100 kHz to 100 MHz when used in a coordinated facility system.
Response Time	<0.5 nanoseconds
Operating Temperature	-40°C to +75°C
Operating Humidity	0% to 95% non-condensing
Warranty	10 Years



## T42 Non-Modular Surge Protective Device 50kA per Phase

T42

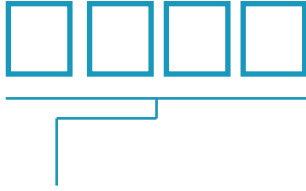

Voltage & Phase Configuration Code

**120N** = 120V Single Phase (L1, N, G) - Fig 1

**240L** = 240V Single Phase (L1, L2, G) - Fig 2



Surge Current Capacity Code  
**025** = 50kA/Phase

A W A J 1 S M

Connection Type

**W** - Wire Lead

UL 1449 Location Type

**1** - Type 1

**Example Product number:**

Filled in:

Complete:

T42 120N 025 A W A J 1 S M = T42120N025AWAJ1SM

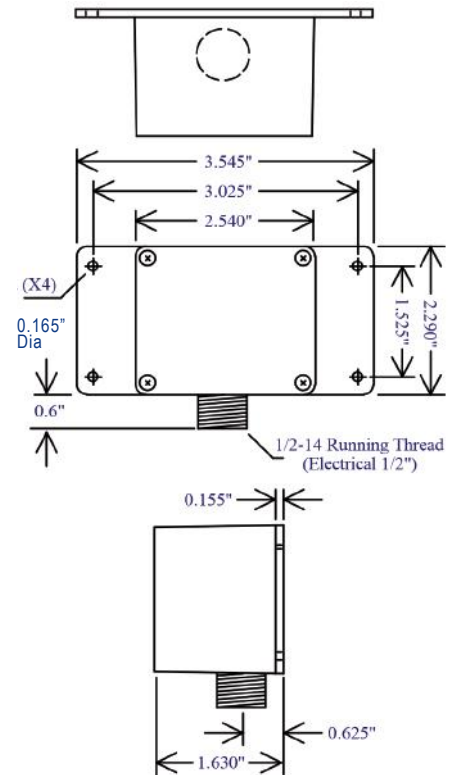
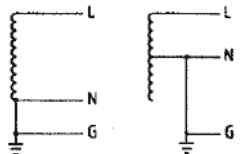
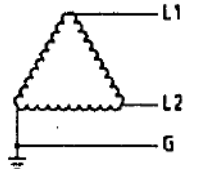

Fig. 1



Single Phase L-N, 2 W + G

Fig. 2



Single Phase L-L, 2 W + G

### System Voltage Compatibility

Model Voltage/ Phase Code	Nominal System Voltages	System Configuration	MCOV	I <sub>n</sub>	SCCR	UL 1449 Voltage Protection Rating			
						L-N	L-G	N-G	L-L
120N	120	Single Phs, 2W+G	150	10kA	200kA	700	700	700	
240L	240	Single Phs, 2W+G	320	10kA	200kA		1200		1200



## T45 Non-Modular Surge Protective Device 50kA per Phase

### 50kA/phase Model



This is the T45 Non-Modular unit in the 50kA per Phase surge current capacity. This T45 Non-Modular Surge Protective Device has a 5.2" x 3.2" x 2.8" NEMA 4X rated polycarbonate enclosure and weighs less than 1.5 pounds, making this the smallest T45 SPD. It has a watertight indoor/outdoor rating, a liquid-tight connector, and external mounting flanges. The flange brackets are removable, and the unit may be mounted with #6 screws. This second mounting location is beneath the cover screws and will exit where the brackets were attached, allowing for an even more compact install. This unit is the perfect fit for applications in which the SPD must fit in a small space or where high-capacity units are not required. These qualities also make this unit especially useful in downstream applications.

This is the smallest T45 unit; however, it is still available in a wide range of voltage and phase configurations. Each protected phase uses combined indication by a singular LED. It has Form "C" dry contact relays for remote indication capabilities. There is a separate "Power" LED to let users know it is energized and functional since the service LED will remain off unless there is a failure. All modes are monitored by the service LED.

It is available as either a UL 1449 Type 1 or Type 2 device. Despite its small size, this SPD in a Type 2 configuration is still equipped with a UL 1283 Listed filter.

This SPD uses advanced Thermally Protected Metal Oxide Varistors. They are in the same rugged MOVs as the larger units in the T45 family, and we continue to use symmetrical surge pathways to allow the unit to take a strike at its full capacity rating.

This unit has 36" of #12 AWG wire leads.

#### Features:

- 50kA/phase available
- Compact and easy to install
- UL 1449 Fourth Edition Listed
- Available in UL 1449 Type 1 or Type 2 Configurations
- Sine Wave Tracking: UL 1449 Type 2  
UL 1283 Listed
- 36" of #12 AWG Wire Leads
- LED Status Indication
- Form "C" Dry Contacts
- Flange style mounting brackets pre-installed

- NEMA 4X rated enclosure for indoor & outdoor use
- Liquid tight connection
- 200kA SCCR
- Lifecycle tested to 12,000 10kA Impulses
- All modes of protection
- Thermally Protected MOVs
- Multiple MOV technology featuring large and robust MOVs
- Equidistant and symmetrical surge pathways for a true surge capacity rating
- 10 Year Warranty



## T45 Non-Modular Surge Protective Device 50kA per Phase

General Technical Specifications	
Connection Type	Parallel, Wire Lead - #12 AWG
Voltage, Phase Configuration	120/240 Split Phase, (3W+G) 120/208V Three Phase Wye, (4W+G)* (127/220V Three Phase Wye, (4W+G))* (220/380V Three Phase Wye, (4W+G))** 277/480V Three Phase Wye (4W+G)** 240V Three Phase Delta (3W+G) 480V Three Phase Delta, (3W+G) 240/480V Three Phase Delta Hi-Leg, (4W+G)
Maximum Continuous Operating Voltage	120V, 150 VAC (125%); 127V, 150 VAC (118%); 220V, 320 VAC (145%); 240V, 320 VAC; 277V, 320 VAC; 480V, 550 VAC; All Others 115%
Surge Capacity	25kA/Mode, 50kA/Phase
Short Circuit Current Rating (SCCR)	200kAIC
Protection Modes	All Modes: L-N, L-L, L-G, N-G
Operating Frequency Range	47 - 63 Hz
UL 1449 Location Type	Type 1 (SPDs intended for Line or Load Side of Main Disconnect) or Type 2 (Intended for Load Side of Main Disconnect)
UL 1449 Nominal Discharge Current (In)	10 kA
Standards	UL 1449 4th Edition, CSA, UL 96A Lightning Protection Master Label compliant
Status Indication	Power and Service LEDs, Form "C" Dry Contact Relay
Enclosure	NEMA 4X Polycarbonate
Dimensions	5.115" x 3.16" x 2.79" (H x W x D)
Weight	1.40 lbs
50 Ohm EMI/RFI Attenuation	-50 db max(Type 2), -45db max(Type 1); from 10 kHz to 100MHz. The system provides up to 120dB insertion loss from 100 kHz to 100 MHz when used in a coordinated facility system.
Response Time	<0.5 nanoseconds
Operating Temperature	-40°C to +75°C
Operating Humidity	0% to 95% non-condensing
Warranty	10 Years

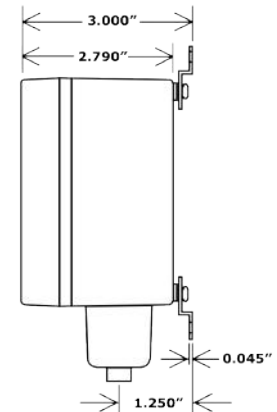
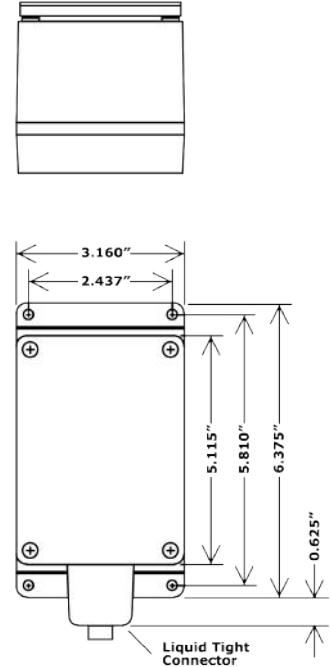

\*This is a 120/208V unit, and can be used in 127/220V applications

\*\*This is a 277/480V unit, and can be used in 220/380V applications



## T45 Non-Modular Surge Protective Device 50kA per Phase

T45

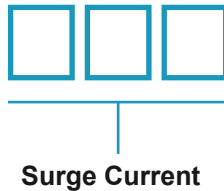
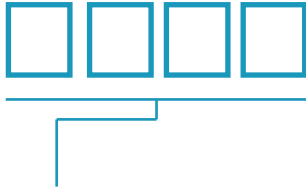

S M

### Voltage & Phase Configuration Code

- 120S** = 120/240V Split Phase (3W+G) - Fig 1
- 120N** = 120V Single Phase (L1, N, G) - Fig 5
- 120Y** = 120/208V 3 Phase Wye, (4W+G)\* - Fig 2
- 127Y** = 127/220V 3 Phase Wye, (4W+G)\* - Fig 2
- 220Y** = 220/380V 3 Phase Wye, (4W+G)\*\* - Fig 2
- 277Y** = 277/480V 3 Phase Wye (4W+G)\*\* - Fig 2
- 240L** = 240V Single Phase (L1, L2, G) - Fig 6
- 240D** = 240V 3 Phase Delta (3W+G) - Fig 3
- 240H** = 240/480V 3 Phase Delta Hi-Leg (4W+G) - Fig 4
- 480D** = 480V 3 Phase Delta, (3W+G) - Fig 3

**Surge Current Capacity Code**  
**025** = 50kA/Phase

**Connection Type**  
**W** - Wire Lead

**UL 1449 Location Type**  
1 - Type 1  
2 - Type 2

### Example Product number:

Filled in:

Complete:

T45 120Y 025 A W AJ 1 S M = T45120Y025AWAJ1SM

Fig. 1

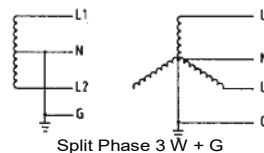
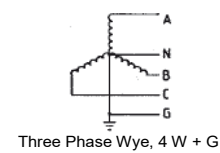

Fig. 2



\*This is a 120/208V unit, and can be used in 127/220V applications

\*\*This is a 277/480V unit, and can be used in 220/380V applications

You may place the order as either part number.

Fig. 3

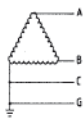

Fig. 4

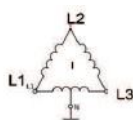

Fig. 5

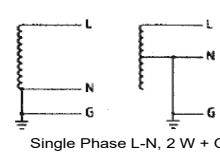
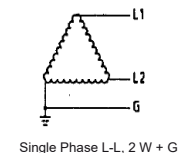

Fig. 6



### System Voltage Compatibility

Model Voltage/Phase Code	Nominal System Voltages	System Configuration	MCOV	I <sub>n</sub>	SCCR	UL 1449 Voltage Protection Rating			
						L-N	L-G	N-G	L-L
120N	120	Single Phs, 2W+G	150	10kA	200kA	700	700	700	
120S	120/240	Split Phs, 3W+G	150	10kA	200kA	700	700	700	1200
120Y	120/208; 127/220	3 Phs Wye, 4W+G	150	10kA	200kA	700	700	700	1200
127Y	120/208; 127/220	3 Phs Wye, 4W+G	150	10kA	200kA	700	700	700	1200
220Y	220/380; 240/415; 277/480	3 Phs Wye, 4W+G	320	10kA	200kA	1200	1200	1200	2000
240L	240	Single Phs, 2W+G	320	10kA	200kA		1200		1200
240H	240/480	3 Phs Delta Hi-leg, 4W+G	320/550	10kA	200kA	1200/1800	1200/1800	1200	2000/3000
277Y	220/380; 240/415; 277/480	3 Phs Wye, 4W+G	320	10kA	200kA	1200	1200	1200	2000
240D	220; 230; 240	3 Phs Delta, 3W+G	320	10kA	200kA		1200		1200
480D	380; 400; 415; 440; 460; 480	3 Phs Delta, 3W+G	550	10kA	200kA		1800		3000
600D	525; 600	3 Phs Delta, 3W+G	690	10kA	200kA		2000		4000



## The “2-In-1” Over/Under Motor Protection System



### Why Install Surge Protection with Dedicated Motor Protection?

Transient impulses can significantly impact your facility's power quality, easily disrupting or damaging your process or equipment. While it's important to protect against high-energy events, a more frequent, yet often overlooked power quality concern is the damage caused by a phase loss, a temporary voltage sag, or a voltage swell condition. Disconnecting your sensitive loads during these longer duration PQ events is the easiest way to safeguard important equipment.

### Why Install a Tier 460 Contactor with an Auto Disconnect and Restart Controller?

The Tier 460 Over/Under Motor Surge Protection system, or the “2-In-1”, will protect a motor, or an entire system, from power quality events. It runs a surge protective device with a series equipped contactor and controller. Our proprietary monitor and control system will disconnect the load at predetermined levels, and will reconnect the load at separate predetermined levels automatically. The SPD remains online while the load is disconnected.

This twofold level of protection greatly improves system defenses from power disruption damage. This unit is also available in a shunt trip configuration.

## Features:

### Surge

- Thermally Protected MOVs
- Surge Levels Available:  
25 kA/Mode, 50kA/Phase
- ANSI/UL 1449 4th Edition, cUL
- Sine Wave Tracking: Type 2
- Surge Impulse Rated and Tested

### Monitoring & Control

- Monitor Under/Over Voltage, Phase Loss, Imbalance
- Audible Alarm w/ disable switch, and LED indication
- Active Load Disconnect & Reset
- User Selectable Controls:  
+/- 5, 7.5, 10, 15, 20, 25% Over/Under Voltage Trip Settings
- Auto restart available with user selectable reset time. Includes: No delay, 5s, 10s, 30s, 1m, 5m, 10m, No restart



## General Technical Specifications

Connection Type	Contactor is Series
Voltage, Phase Configuration	120/240 Split Phase, (3W+G) 120/208V Three Phase Wye, (4W+G)* (127/220V Three Phase Wye, (4W+G))* (220/380V Three Phase Wye, (4W+G))* 277/480V Three Phase Wye (4W+G)** 240V Three Phase Delta (3W+G) 480V Three Phase Delta, (3W+G)
Maximum Continuous Operating Voltage	120V, 150 VAC (125%); 127V, 150 VAC (118%); 220V, 320 VAC (145%); 240V, 320 VAC; 277V, 320 VAC; 480V, 550 VAC; All Others 115%
Short Circuit Current Rating (SCCR)	200kAIC Surge; 22kAIC Contactor
Contactor Current Rating	30, 40, 50, 60, or 90 Amp
Protection Modes	All Connected Modes: L-N, L-L, L-G, N-G
Operating Frequency Range	47 - 63 Hz
UL 1449 Location Type	Type 1 or Type 2
Nominal Discharge Current (In)	10 kA
Connection	Terminals
Status Indication	Blue/Red LEDs, Form C, Audible Alarm w/ disable switch
Monitoring	Under Voltage/ Over Voltage + activation LED, Phase loss, Phase Imbalance
Enclosure	NEMA 4, 12, &13 Rated (16 Gauge Steel)
50 Ohm EMI/RFI Attenuation	-50 db max(Type 2), -45db max(Type 1); from 10 kHz to 100MHz. The system provides up to 120dB insertion loss from 100 kHz to 100 MHz when used in a coordinated facility system.
Response Time	<0.5 nanoseconds
Operating Temperature	-40°C to +75°C
Operating Humidity	0% to 95% non-condensing
50 kA/Phase Case Size	M2 - 12" x 12" x 6" M3 - 16" x 16" x 6"
Selectable Over/Under Voltage Trigger Levels	+/- 5%, 7.5%, 10%, 15%, 20%, 25%
Contactor Options for Auto Reset	Selectable resets: No Delay, 5s, 10s, 30s, 1m, 5m, 10m, No Restart
Warranty	SPD: 10 years; Control System: 5 years

**M2 Enclosure**

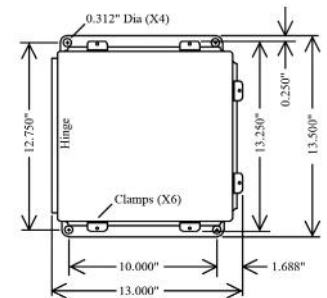

**M3 Enclosure**

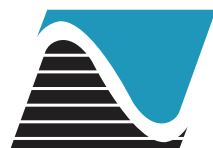
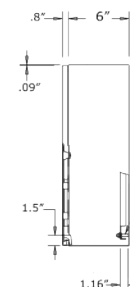
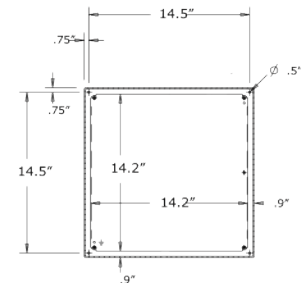
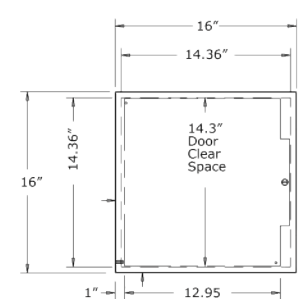

**T46**  **025 AL**   **S**  **M**

### Voltage & Phase Configuration Code

- 120S** = 120/240V Split Phase (3W+G)- Fig 1
- 120Y** = 120/208V 3 Phase Wye, (4W+G)\* - Fig 2
- 127Y** = 127/220V 3 Phase Wye, (4W+G)\* - Fig 2
- 220Y** = 220/380V 3 Phase Wye, (4W+G)\*\* - Fig 2
- 277Y** = 277/480V 3 Phase Wye (4W+G)\*\* - Fig 2
- 240D** = 240V 3 Phase Delta (3W+G) - Fig 3
- 240H** = 240/480V 3 Phase Delta Hi-Leg (4W+G) - Fig 4
- 480D** = 480V 3 Phase Delta, (3W+G) - Fig 3

\*This is a 120/208V unit, and can be used in 127/220V applications

\*\*This is a 277/480V unit, and can be used in 220/380V applications

You may place the order as either part number.

### Enclosure

- M2** - 12x12x6
- M3** - 16x16x6

Enclosure size is determined based on selected options. Please see pre-configured options on product list.

### 1449 Location

- 1** - UL Type 1
- 2** - UL Type 2

### Current Rating

- 03** - 30 Amp
- 04** - 40 Amp
- 05** - 50 Amp
- 06** - 60 Amp
- 09** - 90 Amp

### Example Product number:

Filled in:

Complete:

T46 120Y 025 AL M3 1 S 09 M = T46120Y025ALM31S09M

## Tier 460 - 2-In-1 Over/Under SPD - Product List

Product Number	Surge Rating	Current Rating	Enclosure (HxWxD)	Weight
<b>2-In-1 Over/Under Motor Surge System: SPD, Contactor, and Controller</b>				
T46XXX025ALM2XS03M	25 kA/Mode, 50 kA/Phase	30 Amps	M2 - 12" x 12" x 6"	21 lbs
T46XXX025ALM2XS04M		40 Amps	M2 - 12" x 12" x 6"	21.5 lbs
T46XXX025ALM3XS05M		50 Amps	M3 - 16" x 16" x 6"	26.5 lbs
T46XXX025ALM3XS06M		60 Amps	M3 - 16" x 16" x 6"	27 lbs
T46XXX025ALM3XS09M		90 Amps	M3 - 16" x 16" x 6"	28 lbs

Fig. 1

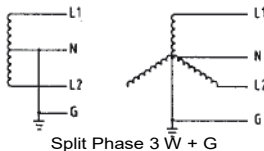

Fig. 2

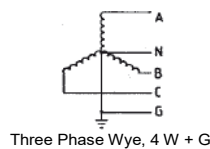

Fig. 3

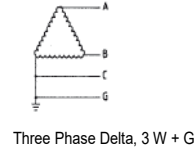
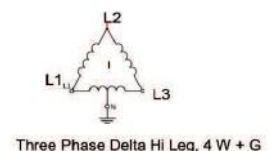

Fig. 4



## The “3-In-1” Power Quality System



## Why Install a Tier 470 Contactor with an Auto Disconnect and Restart Controller, a Line Reactor, and SPD?

The Tier 470 Power Quality System is a motor surge protection contactor restart device with a line reactor, or the “3-In-1”. It will protect a motor, or an entire system, from power quality events. It runs a surge protective device with a series contactor, a line reactor, and our proprietary monitor and control system.

The contactor will disconnect the load at predetermined levels, and will reconnect the load at separate predetermined levels automatically. The SPD remains online while the load is disconnected. The line reactor will limit Inrush current, along with starting and peak current; as well as reducing low frequency interference, current harmonics, distortion of reactive power, circuit feedback, and losses at the line transformer and in neutral wire loads.

This “3-In-1” Power Quality System rigorously defends your essential equipment from damaging disruptions. If you are experiencing power quality anomalies that you have not been able to identify or remediate, or are continuously replacing equipment due to damage from a known process; this unit may provide the solution you have been looking for.

## Features:

### Surge

- Thermally Protected MOVs
- Surge Levels Available:  
25 kA/Mode, 50kA/Phase
- ANSI/UL 1449 4th Edition, cUL
- Sine Wave Tracking: Type 2
- Surge Impulse Rated and Tested

### Line Reactor

- Inrush Current Limitation
- Starting and Peak Current Limitation
- Circuit Feedback Protection
- Harmonic Mitigation
- Reduction in Losses

### Monitoring & Control

- Monitor Under/Over voltage, Phase Loss, Imbalance
- Audible Alarm w/ disable switch, and LED indication
- Active Load Disconnect & Reset
- User Selectable Controls:  
+/- 5, 7.5, 10, 15, 20, 25% Over/Under Voltage Trip Settings
- Auto restart available with user selectable reset time. Includes: No delay, 5s, 10s, 30s, 1m, 5m, 10m, No restart



## General Technical Specifications

Connection Type	Contactor and Line Reactor are Series
Voltage, Phase Configuration	120/240 Split Phase, (3W+G) 120/208V Three Phase Wye, (4W+G)* (127/220V Three Phase Wye, (4W+G))* (220/380V Three Phase Wye, (4W+G))* 277/480V Three Phase Wye (4W+G)** 240V Three Phase Delta (3W+G) 480V Three Phase Delta, (3W+G)
Maximum Continuous Operating Voltage	120V, 150 VAC (125%); 127V, 150 VAC (118%); 220V, 320 VAC (145%); 240V, 320 VAC; 277V, 320 VAC; 480V, 550 VAC; All Others 115%
Short Circuit Current Rating (SCCR)	200kAIC Surge; 22kAIC Contactor
Contactor Current Rating	30, 40, 50, 60 Amps
Line Reactor Current Rating	30, 40, 50, 60(Typically matches Contactor)
Line Reactor Impedance	3% or 5%
Protection Modes	All Connected Modes: L-N, L-L, L-G, N-G
Operating Frequency Range	47 - 63 Hz
UL 1449 Location Type	Type 1 or Type 2
Nominal Discharge Current (In)	10 kA
Connection	Terminals
Status Indication	Blue/Red LEDs, Form C, Audible Alarm w/ disable switch
Monitoring	Under Voltage/ Over Voltage + activation LED, Phase loss, Phase Imbalance
Enclosure	NEMA 4, 12, & 13 Rated (16 Gauge Steel)
50 Ohm EMI/RFI Attenuation	-50 db max(Type 2), -45db max(Type 1); from 10 kHz to 100MHz. The system provides up to 120dB insertion loss from 100 kHz to 100 MHz when used in a coordinated facility system.
Response Time	<0.5 nanoseconds
Operating Temperature	-40°C to +75°C
Operating Humidity	0% to 95% non-condensing
3-in-1 50kA/Phase Case Size	M2 12" x 12" x 6" M4 20" x 16" x 10" Note: Different dimensions may be required as size depends on bend needed for wire per NEC
Selectable Over/Under Voltage Trigger Levels	+/- 5%, 7.5%, 10%, 15%, 20%, 25%
Contactor Options for Auto Reset	Selectable resets: No Delay, 5s, 10s, 30s, 1m, 5m, 10m, No Restart
Warranty	SPD: 10 years Control System and Line Reactor: 5 Years

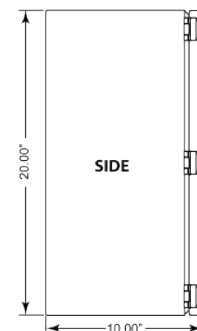
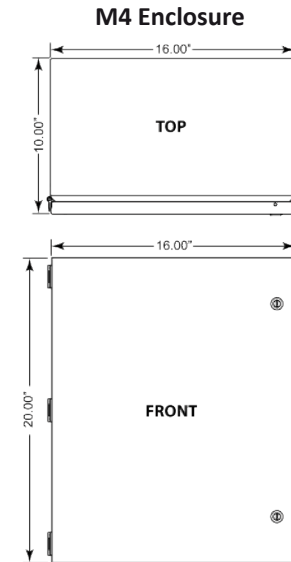
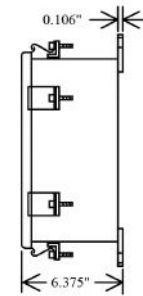
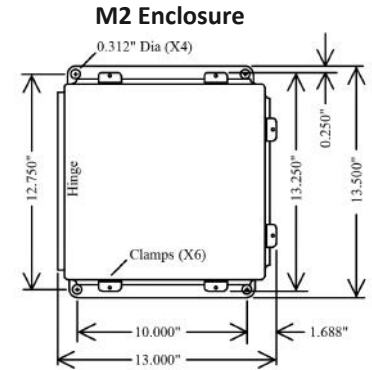

**T47**  **025 AL**     **M**

### Voltage & Phase Configuration Code

- 120S** = 120/240V Split Phase (3W+G)- Fig 1
- 120Y** = 120/208V 3 Phase Wye, (4W+G)\* - Fig 2
- 127Y** = 127/220V 3 Phase Wye, (4W+G)\* - Fig 2
- 220Y** = 220/380V 3 Phase Wye, (4W+G)\*\* - Fig 2
- 277Y** = 277/480V 3 Phase Wye (4W+G)\*\* - Fig 2
- 240D** = 240V 3 Phase Delta (3W+G) - Fig 3
- 240H** = 240/480V 3 Phase Delta Hi-Leg (4W+G) - Fig 4
- 480D** = 480V 3 Phase Delta, (3W+G) - Fig 3

- Enclosure**  
**M2** - 12x12x6  
**M4** - 20x16x10

Enclosure size is determined based on selected options. Please see pre-configured options on product list.

- 1449 Location**  
**1** - UL Type 1  
**2** - UL Type 2

### Options

- 3** - 3% Line Reactor
- 5** - 5% Line Reactor

- Current Rating\***  
**03** - 30 Amp  
**04** - 40 Amp  
**05** - 50 Amp  
**06** - 60 Amp

\*Line Reactor Current Size will Match Contactor Current Size Selection in Position 17-18 of the product number.

\*This is a 120/208V unit, and can be used in 127/220V applications

\*\*This is a 277/480V unit, and can be used in 220/380V applications

You may place the order as either part number.

### Example Product number:

Filled in:

Complete:

T47 120Y 025 AL M4 1 3 06 M = T47120Y025ALM41306M

## Tier 470 - 3-In-1 Power Quality Systems - Product List

Product Number	Surge Rating	Current Rating	Enclosure (HxWxD)	Weight
<b>3-In-1 Power Quality System: SPD, Contactor, Controller, and Line Reactor 3%</b>				
T47XXX025ALM2X303M	25 kA/Mode, 50 kA/Phase	30 Amps	M2 - 12" x 12" x 6"	33 lbs
T47XXX025ALM2X304M		40 Amps	M2 - 12" x 12" x 6"	37 lbs
T47XXX025ALM4X305M		50 Amps	M4 - 20" x 16" x 10"	50 lbs
T47XXX025ALM4X306M		60 Amps	M4 - 20" x 16" x 10"	51 lbs
Product Number	Surge Rating	Current Rating	Enclosure	Weight
<b>3-In-1 Power Quality System: SPD, Contactor, Controller, and Line Reactor 5%</b>				
T47XXX025ALM2X503M	25 kA/Mode, 50 kA/Phase	30 Amps	M2 - 12" x 12" x 6"	37 lbs
T47XXX025ALM2X504M		40 Amps	M2 - 12" x 12" x 6"	41 lbs
T47XXX025ALM4X505M		50 Amps	M4 - 20" x 16" x 10"	58 lbs
T47XXX025ALM4X506M		60 Amps	M4 - 20" x 16" x 10"	61 lbs

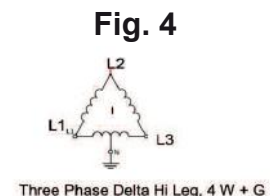
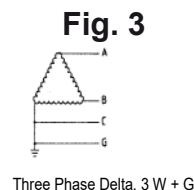
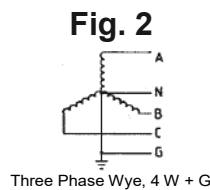
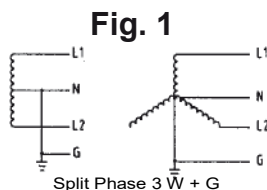

## T71 Non-Modular Surge Protective Device High Energy Series 100kA per Phase

### 100kA/phase Model

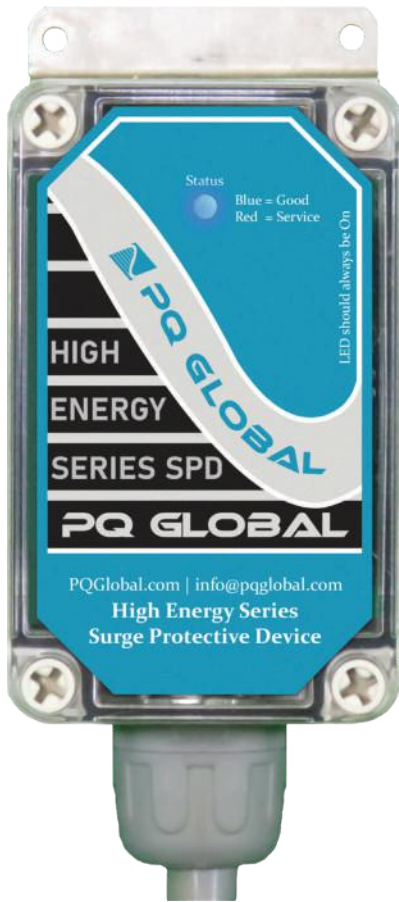

This is the T71 Non-Modular unit in the 100kA per Phase surge current capacity, a member of the Tier 700 High-Energy Surge Protection family of products. This T71 Non-Modular Surge Protective Device has a 5.2" x 3.2" x 2.8" NEMA 4X rated polycarbonate enclosure and weighs less than 1.5 pounds, making this the smallest T71 SPD.

This SPD uses Enhanced Thermally Protected Metal Oxide Varistors. These are a UL 5th Edition High-Energy version of our Tier 400 Series SPD MOVs, taking our robust MOVs to even greater protection capabilities in a similar-sized enclosure.

It has a watertight indoor/outdoor rating, a liquid-tight connector, and external mounting flanges. This unit is the perfect fit for applications in which the SPD must fit in a small space, but still needs higher energy surge current capacity protection. These qualities also make this unit especially useful in downstream applications where more demanding protection is required.

This is the smallest T71 unit; however, it is still available in a wide range of voltage and phase configurations. Each protected phase uses combined indication by a singular LED, each mode is monitored. It has Form "C" dry contact relays for remote indication capabilities. It uses a dual-color LED, so regardless of unit status, it will remain lit to let users know it is energized and functional. If the LED is off, it likely indicates an issue with the installation, facility, or power to the unit.

It is available as either a UL 1449 Type 1 or Type 2 device. Despite its small size, this SPD in a Type 2 configuration is still equipped with a UL 1283 Listed filter.

This unit has 36" of #12 AWG wire leads.

#### Features:

- 100kA/phase available
- Compact and easy to install
- UL 1449 Fifth Edition Listed
- Available in UL 1449 Type 1 or Type 2 Configurations
- Sine Wave Tracking: UL 1449 Type 2  
UL 1283 Listed
- 36" of #12 AWG Wire Leads
- LED Status Indication
- Form "C" Dry Contacts
- Flange style mounting brackets pre-installed

- NEMA 4X rated enclosure for indoor & outdoor use
- Liquid tight connection
- 200kA SCCR
- Lifecycle tested to 12,000 10kA Impulses
- All modes of protection
- Thermally Protected MOVs
- Multiple MOV technology featuring large and robust MOVs
- Equidistant and symmetrical surge pathways for a true surge capacity rating
- 10 Year Warranty



## T71 Non-Modular Surge Protective Device High Energy Series 100kA per Phase

General Technical Specifications	
Connection Type	Parallel, Wire Lead - #12 AWG
Voltage, Phase Configuration	120/240 Split Phase, (3W+G) 120/208V Three Phase Wye, (4W+G)* (127/220V Three Phase Wye, (4W+G))* (220/380V Three Phase Wye, (4W+G))** 277/480V Three Phase Wye (4W+G)** 240V Three Phase Delta (3W+G) 480V Three Phase Delta, (3W+G) 240/480V Three Phase Delta Hi-Leg, (4W+G)
Maximum Continuous Operating Voltage	120V, 150 VAC (125%); 127V, 150 VAC (118%); 220V, 320 VAC (145%); 240V, 320 VAC; 277V, 320 VAC; 480V, 550 VAC; All Others 115%
Surge Capacity	50kA/Mode, 100kA/Phase
Short Circuit Current Rating (SCCR)	200kAIC
Protection Modes	All Modes: L-N, L-L, L-G, N-G
Operating Frequency Range	47 - 63 Hz
UL 1449 Location Type	Type 1 (SPDs intended for Line or Load Side of Main Disconnect) or Type 2 (Intended for Load Side of Main Disconnect)
UL 1449 Nominal Discharge Current (In)	20 kA
Standards	UL 1449 5th Edition, CSA, UL 96A Lightning Protection Master Label compliant
Status Indication	Each phase is monitored, and uses combined indication by a single dual-color LED
Enclosure	NEMA 4X Polycarbonate
Dimensions	5.115" x 3.16" x 2.79" (H x W x D)
Weight	1.40 lbs
50 Ohm EMI/RFI Attenuation	-50 db max(Type 2), -45db max(Type 1); from 10 kHz to 100MHz. The system provides up to 120dB insertion loss from 100 kHz to 100 MHz when used in a coordinated facility system.
Response Time	<0.5 nanoseconds
Operating Temperature	-40°C to +75°C
Operating Humidity	0% to 95% non-condensing
Warranty	10 Years

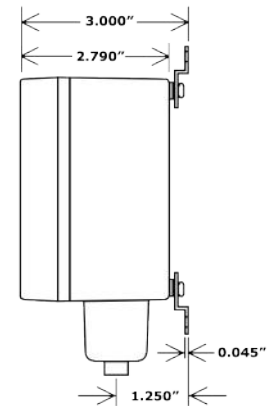
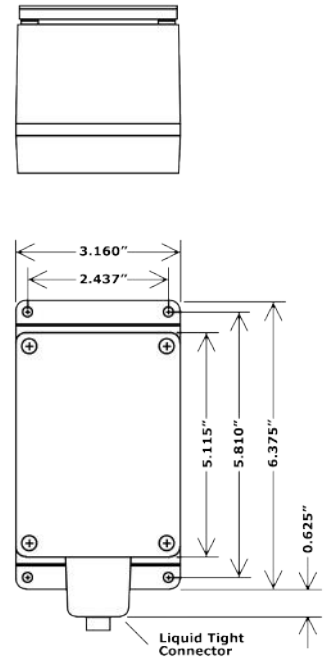

\*This is a 120/208V unit, and can be used in 127/220V applications

\*\*This is a 277/480V unit, and can be used in 220/380V applications



## T71 Non-Modular Surge Protective Device High Energy Series 100kA per Phase



### Voltage & Phase Configuration Code

- 120S** = 120/240V Split Phase (3W+G) - Fig 1
- 120N** = 120V Single Phase (L1, N, G) - Fig 5
- 120Y** = 120/208V 3 Phase Wye, (4W+G)\* - Fig 2
- 127Y** = 127/220V 3 Phase Wye, (4W+G)\* - Fig 2
- 220Y** = 220/380V 3 Phase Wye, (4W+G)\*\* - Fig 2
- 277Y** = 277/480V 3 Phase Wye (4W+G)\*\* - Fig 2
- 240L** = 240V Single Phase (L1, L2, G) - Fig 6
- 240D** = 240V 3 Phase Delta (3W+G) - Fig 3
- 240H** = 240/480V 3 Phase Delta Hi-Leg (4W+G) - Fig 4
- 480D** = 480V 3 Phase Delta, (3W+G) - Fig 3

### Surge Current Capacity Code

**050** = 100kA/Phase

### Connection Type

**W** - Wire Lead

### Status

**L0** - LED +  
Form C Relay

### UL 1449 Location Type

**1** - Type 1  
**2** - Type 2

### Modes

- A** - All Connected Modes
- G** - Neutral Delete (L-L & L-G Only)

### Example Product number:

Filled in:

T71 120Y 050 A W P2 L0 1 M

Complete:

T71120Y050AWP2L01M

\*This is a 120/208V unit, and can be used in 127/220V applications

\*\*This is a 277/480V unit, and can be used in 220/380V applications

You may place the order as either part number.

**Fig. 1**

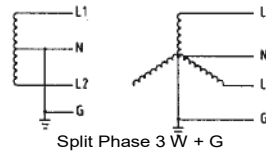

**Fig. 2**

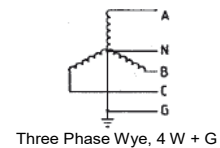

**Fig. 3**

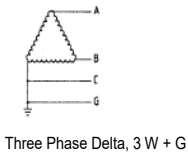

**Fig. 4**

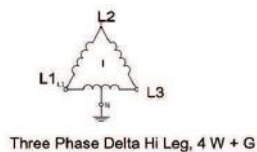

**Fig. 5**

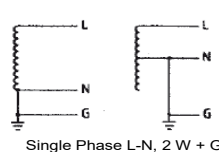

**Fig. 6**

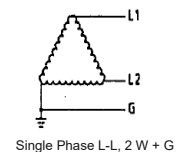

### System Voltage Compatibility

Model Voltage/Phase Code	Nominal System Voltages	System Configuration	MCOV	I <sub>n</sub>	SCCR	UL 1449 Voltage Protection Rating			
						L-N	L-G	N-G	L-L
<b>120N</b>	120	Single Phs, 2W+G	150	20kA	200kA	700	700	700	
<b>120S</b>	120/240	Split Phs, 3W+G	150	20kA	200kA	700	700	700	1200
<b>120Y</b>	120/208; 127/220	3 Phs Wye, 4W+G	150	20kA	200kA	700	700	700	1200
<b>127Y</b>	120/208; 127/220	3 Phs Wye, 4W+G	150	20kA	200kA	700	700	700	1200
<b>220Y</b>	220/380; 240/415; 277/480	3 Phs Wye, 4W+G	320	20kA	200kA	1200	1200	1200	2000
<b>240L</b>	240	Single Phs, 2W+G	320	20kA	200kA		1200		1200
<b>240H</b>	240/480	3 Phs Delta Hi-leg, 4W+G	320/550	20kA	200kA	1200/1800	1200/1800	1200	2000/3000
<b>277Y</b>	220/380; 240/415; 277/480	3 Phs Wye, 4W+G	320	20kA	200kA	1200	1200	1200	2000
<b>240D</b>	220; 230; 240	3 Phs Delta, 3W+G	320	20kA	200kA		1200		1200
<b>480D</b>	380; 400; 415; 440; 460; 480	3 Phs Delta, 3W+G	550	20kA	200kA		1800		3000



## T45 Non-Modular Surge Protective Device 100kA - 300kA per Phase

### 100kA/phase - 300kA/phase Model



This is the T45 Non-Modular unit in the 100kA - 300kA per Phase surge current capacity range.

This T45 Non-Modular Surge Protective Device has a 8" x 6" x 4" NEMA 4X rated polycarbonate enclosure. This unit is highly versatile due to the small form factor, the watertight indoor/outdoor rating, and the external mounting flanges. These features allow this unit to be placed in most locations that require an SPD, without taking up much space or requiring time-consuming mounting procedures.

This unit is more compact than its modular counterpart, but it still houses a full array of status indication. Each protected phase is separately indicated by a dual-color LED; it has an audible alarm with a silence switch and Form "C" Relays. It is also available with an externally viewable surge counter(optional).

It is available in surge current capacities from 100kA - 300kA/phase, in increments of 50kA/phase spanning the range. The large range of current capacity is another testament to the versatility of this unit. It can be placed anywhere that the larger Terminal Block unit in the same capacity range can go, provided the wire size properly fits the application and there is no need for a steel enclosure.

The modules use advanced Thermally Protected Metal Oxide Varistors. The large-capacity MOVs with symmetrical surge pathways allow these modules to take a strike at their full capacity rating. They come in a variety of voltage and phase configurations. UL 1449 Type 2 configurations have a UL 1283 listed filter installed.

This SPD has 5ft of #10 AWG wire leads.

#### Features:

- 100kA, 150kA, 200kA, 250kA & 300kA/phase available
- Compact and easy to install
- UL 1449 Fourth Edition Listed
- Available in UL 1449 Type 1 or Type 2 Configurations
- Sine Wave Tracking: UL 1449 Type 2  
UL 1283 Listed
- Audible Alarm with a Disable Switch
- Per Phase Dual LED Status Indication
- Form C Dry Contacts
- Flange style mounting brackets pre-installed

- NEMA 4X rated enclosure for indoor & outdoor use
- 20kA Inominal
- 200kA SCCR
- Lifecycle tested to 12,000 10kA Impulses
- All modes of protection
- Thermally Protected MOVs
- Multiple MOV technology featuring large and robust MOVs
- Equidistant and symmetrical surge pathways for a true surge capacity rating
- 10 Year Warranty



## T45 Non-Modular Surge Protective Device 100kA - 300kA per Phase

General Technical Specifications	
Connection Type	Parallel, Wire Lead - #10 AWG
Voltage, Phase Configuration	120/240 Split Phase, (3W+G) 120/208V Three Phase Wye, (4W+G)* (127/220V Three Phase Wye, (4W+G))* (220/380V Three Phase Wye, (4W+G))** 277/480V Three Phase Wye (4W+G)** 240V Three Phase Delta (3W+G) 480V Three Phase Delta, (3W+G) 240/480V Three Phase Delta Hi-Leg, (4W+G)
Maximum Continuous Operating Voltage	120V, 150 VAC (125%); 127V, 150 VAC (118%); 220V, 320 VAC (145%); 240V, 320 VAC; 277V, 320 VAC; 480V, 550 VAC; All Others 115%
Surge Capacity	50 kA/Mode, 100kA/Phase 75 kA/Mode, 150kA/Phase 100 kA/Mode, 200kA/Phase 125 kA/Mode, 250kA/Phase 150 kA/Mode, 300kA/Phase
Short Circuit Current Rating (SCCR)	200kAIC
Protection Modes	All Modes: L-N, L-L, L-G, N-G
Operating Frequency Range	47 - 63 Hz
UL 1449 Location Type	Type 1 (SPDs intended for Line or Load Side of Main Disconnect) or Type 2 (Intended for Load Side of Main Disconnect)
UL 1449 Nominal Discharge Current (In)	20 kA
Standards	UL 1449 4th Edition, CSA, UL 96A Lightning Protection Master Label compliant
Status Indication	Dual Colored LEDs, Audible Alarm, Form C Relay, Surge Counter(Optional)
Enclosure	NEMA 4X Polycarbonate
Dimensions	7.87" x 5.90" x 3.98" (H x W x D)
Weight	5.3 lbs
50 Ohm EMI/RFI Attenuation	-50 db max(Type 2), -45db max(Type 1); from 10 kHz to 100MHz. The system provides up to 120dB insertion loss from 100 kHz to 100 MHz when used in a coordinated facility system.
Response Time	<0.5 nanoseconds
Operating Temperature	-40°C to +75°C
Operating Humidity	0% to 95% non-condensing
Warranty	10 Years

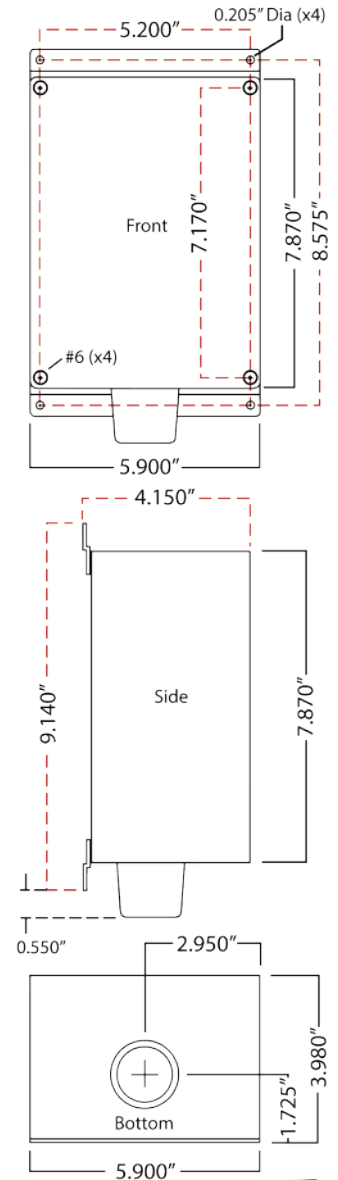

\*This is a 120/208V unit, and can be used in 127/220V applications

\*\*This is a 277/480V unit, and can be used in 220/380V applications



## T45 Non-Modular Surge Protective Device 100kA - 300kA per Phase

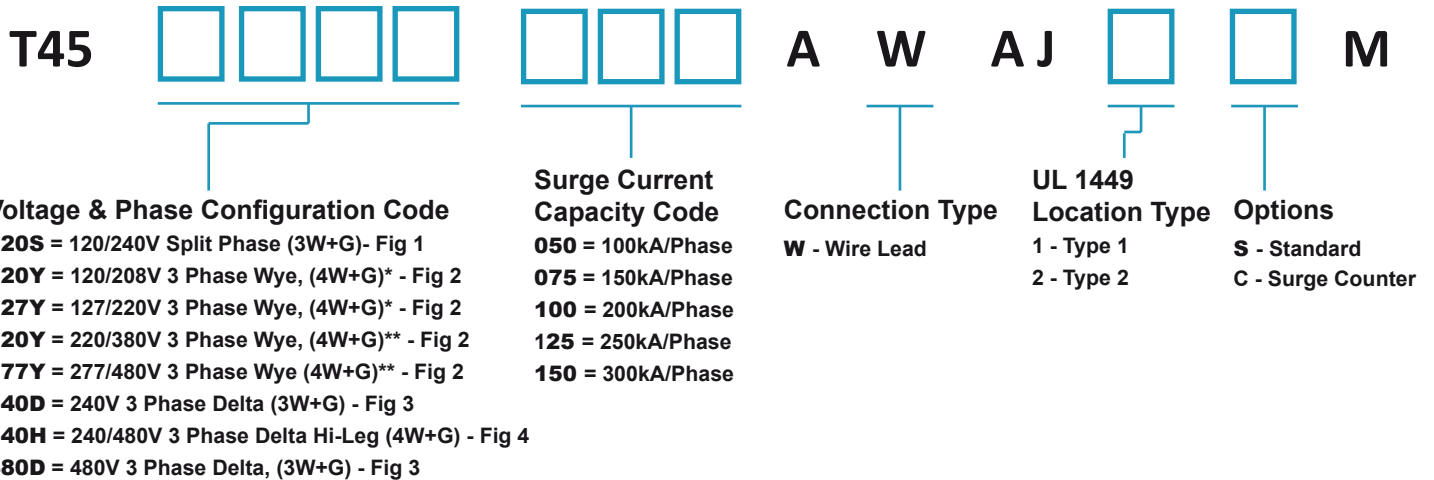

\*This is a 120/208V unit, and can be used in 127/220V applications

\*\*This is a 277/480V unit, and can be used in 220/380V applications

You may place the order as either part number.

### Example Product number:

Filled in:

T45 120Y 100 A W AJ 1 S M =

Complete:

T45120Y100AWAJ1SM

Fig. 1

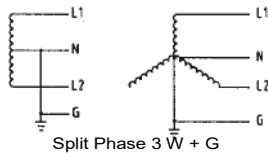

Fig. 2

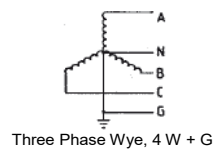

Fig. 3

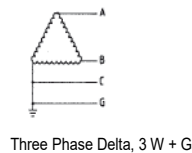
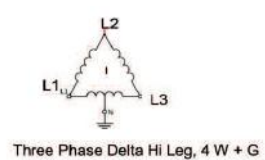

Fig. 4



### System Voltage Compatibility

Model Voltage/ Phase Code	Nominal System Voltages	System Configuration	MCOV	I <sub>n</sub>	SCCR	UL 1449 Voltage Protection Rating			
						L-N	L-G	N-G	L-L
120S	120/240	Split Phs, 3W+G	150	20kA	200kA	600	700	700	1200
120Y	120/208; 127/220	3 Phs Wye, 4W+G	150	20kA	200kA	600	700	700	1200
127Y	120/208; 127/220	3 Phs Wye, 4W+G	150	20kA	200kA	600	700	700	1200
220Y	220/380; 240/415; 277/480	3 Phs Wye, 4W+G	320	20kA	200kA	1200	1200	1200	2000
240L	240	Single Phs, 2W+G	320	20kA	200kA		1200		1200
240H	240/480	3 Phs Delta Hi-leg, 4W+G	320/550	20kA	200kA	1200/1800	1200/1800	1200	2000/3000
277Y	220/380; 240/415; 277/480	3 Phs Wye, 4W+G	320	20kA	200kA	1200	1200	1200	2000
240D	220; 230; 240	3 Phs Delta, 3W+G	320	20kA	200kA		1200		1200
480D	380; 400; 415; 440; 460; 480	3 Phs Delta, 3W+G	550	20kA	200kA		1800		2000



### 100kA/phase - 300kA/phase Models

#### Terminal Block Option



These units are the T45 Modular units in the 100kA - 300kA per Phase surge current capacity range. These T45 Modular Surge Protective Devices have a 12" x 12" x 6" NEMA 4 rated steel exterior enclosure. This unit houses a surge module inside that is additionally protected by a NEMA 4X rated polycarbonate enclosure. This helps protect the surge modules during shipping, installation, and provides an extra level of personal safety.

These are modular units; in the event of a module failure or the need to upgrade capacity, the module may be removed and replaced without disturbing the mounted external enclosure or the unit's wiring connections. Due to the internal module being in a NEMA 4X enclosure, replacement and upgraded modules are quick and easy to install, with a greatly mitigated risk of damage from the installer. After disconnecting power, the installer must simply attach the encased module to the mount, and connect the wires to the terminal block.

#### Rotary Disconnect Option



The modules use advanced Thermally Protected Metal Oxide Varistors. The large-capacity MOVs with symmetrical surge pathways allow these modules to take a strike at their full capacity rating. They come in a variety of voltage and phase configurations. Each module houses dual LED status lights that indicate per phase health, Form "C" dry contact relays, and an Audible Alarm with a silence switch. The module also contains a Surge Counter that is externally viewable. The integrated external mount flange makes mounting quick and easy.

This unit utilizes a terminal block connection that allows for a connection range from #10AWG to 2/0. It is available with a rotary disconnect option.

#### Features:

- 100kA, 150kA, 200kA, 250kA & 300kA/phase available
- Replaceable & Upgradable Module
- UL 1449 Fourth Edition Listed
- Available in UL 1449 Type 1 or Type 2 Configurations
- Sine Wave Tracking: UL 1449 Type 2  
UL 1283 Listed
- Audible Alarm with a Disable Switch
- Per Phase Dual LED Status Indication
- Externally Viewable Surge Counter
- Form C Dry Contacts

- NEMA 4 Steel Unit with NEMA 4X encased module installed inside
- 20kA Inominal
- 200kA SCCR
- Lifecycle tested to 12,000 10kA Impulses
- All modes of protection
- Thermally Protected MOVs
- Multiple MOV technology featuring large and robust MOVs
- Equidistant and symmetrical surge pathways for a true surge capacity rating
- 10 Year Warranty



## T45 Modular Surge Protective Device 100kA - 300kA per Phase

General Technical Specifications	
Connection Type	Parallel, Terminal Lugs - #10AWG - 2/0 AWG Disconnect - #10AWG - 1/0
Voltage, Phase Configuration	120/240 Split Phase, (3W+G) 120/208V Three Phase Wye, (4W+G)* (127/220V Three Phase Wye, (4W+G))* (220/380V Three Phase Wye, (4W+G))* 277/480V Three Phase Wye (4W+G)** 240V Three Phase Delta (3W+G) 480V Three Phase Delta, (3W+G)
Maximum Continuous Operating Voltage	120V, 150 VAC (125%); 127V, 150 VAC (118%); 220V, 320 VAC (145%); 240V, 320 VAC; 277V, 320 VAC; 480V, 550 VAC; All Others 115%
Surge Capacity	50 kA/Mode, 100kA/Phase 75 kA/Mode, 150kA/Phase 100 kA/Mode, 200kA/Phase 125 kA/Mode, 250kA/Phase 150 kA/Mode, 300kA/Phase
Short Circuit Current Rating (SCCR)	200kAIC
Protection Modes	All Modes: L-N, L-L, L-G, N-G
Operating Frequency Range	47 - 63 Hz
UL 1449 Location Type	Type 1 (SPDs intended for Line or Load Side of Main Disconnect) or Type 2 (Intended for Load Side of Main Disconnect)
UL 1449 Nominal Discharge Current (In)	20 kA
Standards	UL 1449 4th Edition, CSA, UL 96A Lightning Protection Master Label compliant
Status Indication	Dual Colored LEDs, Audible Alarm, Form C Relay, Surge Counter
Enclosure	NEMA 4, 12, & 13 Rated
Weight	21 lbs
Dimensions	12" x 12" x 6.375"
50 Ohm EMI/RFI Attenuation	-50 db max(Type 2), -45db max(Type 1); from 10 kHz to 100MHz. The system provides up to 120dB insertion loss from 100 kHz to 100 MHz when used in a coordinated facility system.
Response Time	<0.5 nanoseconds
Operating Temperature	-40°C to +75°C
Operating Humidity	0% to 95% non-condensing
Warranty	10 Years

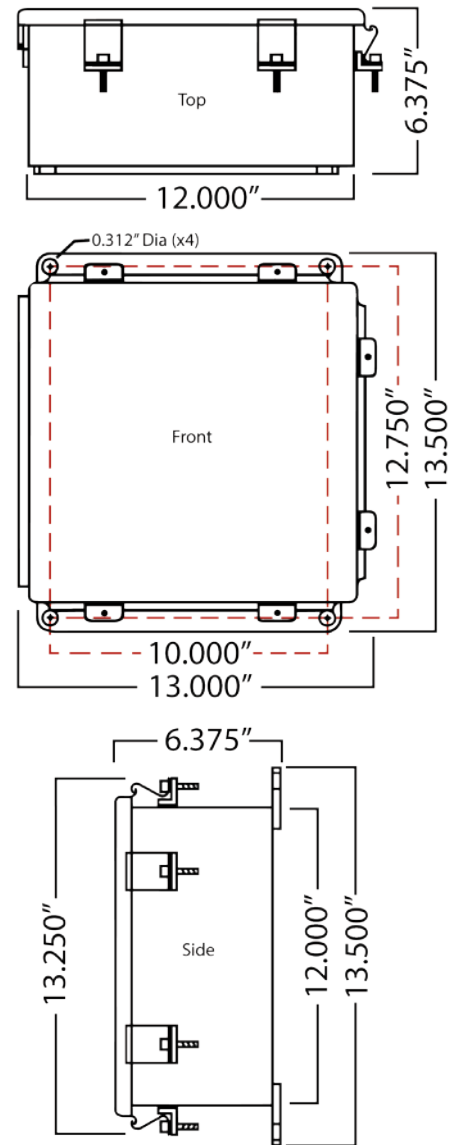

\*This is a 120/208V unit, and can be used in 127/220V applications

\*\*This is a 277/480V unit, and can be used in 220/380V applications



## T45 Modular Surge Protective Device 100kA - 300kA per Phase

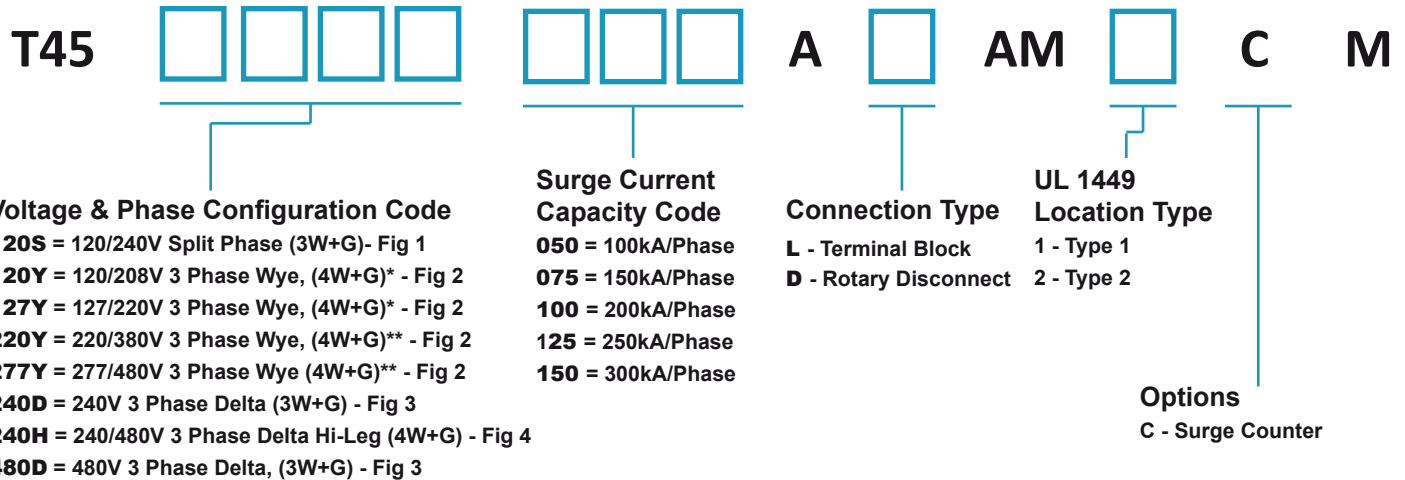

\*This is a 120/208V unit, and can be used in 127/220V applications

\*\*This is a 277/480V unit, and can be used in 220/380V applications

You may place the order as either part number.

### Example Product number:

Filled in:

Complete:

T45 120Y 150 A L AM 1 C M = T45120Y150ALAM1CM

**Fig. 1**

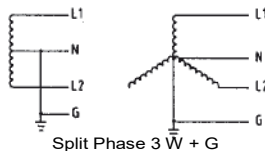

**Fig. 2**

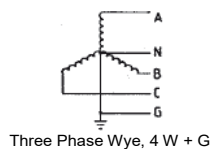

**Fig. 3**

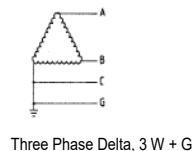

**Fig. 4**

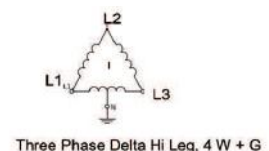

### System Voltage Compatibility

Model Voltage/Phase Code	Nominal System Voltages	System Configuration	MCOV	I <sub>n</sub>	SCCR	UL 1449 Voltage Protection Rating			
						L-N	L-G	N-G	L-L
<b>120S</b>	120/240	Split Phs, 3W+G	150	20kA	200kA	700	700	700	1200
<b>120Y</b>	120/208; 127/220	3 Phs Wye, 4W+G	150	20kA	200kA	700	700	700	1200
<b>127Y</b>	120/208; 127/220	3 Phs Wye, 4W+G	150	20kA	200kA	700	700	700	1200
<b>220Y</b>	220/380; 240/415; 277/480	3 Phs Wye, 4W+G	320	20kA	200kA	1000	1000	1000	1800
<b>240L</b>	240	Single Phs, 2W+G	320	20kA	200kA		1200		1200
<b>240H</b>	240/480	3 Phs Delta Hi-leg, 4W+G	320/550	20kA	200kA	1200/1800	1200/1800	1200	2000/3000
<b>277Y</b>	220/380; 240/415; 277/480	3 Phs Wye, 4W+G	320	20kA	200kA	1000	1000	1000	1800
<b>240D</b>	220; 230; 240	3 Phs Delta, 3W+G	320	20kA	200kA		1200		1200
<b>480D</b>	380; 400; 415; 440; 460; 480	3 Phs Delta, 3W+G	550	20kA	200kA		1800		2000



### 400kA/phase - 600kA/phase Models

#### Terminal Block Option



These units are the T45 Modular units in the 400kA - 600kA per Phase surge current capacity range. These T45 Modular Surge Protective Devices have a 16" x 16" x 6" NEMA 4 rated steel exterior enclosure. This unit houses two surge modules, each within their own NEMA 4X rated polycarbonate enclosure. This helps protect the surge modules during shipping, installation, and provides an extra level of personal safety.

These are modular units; in the event of a module failure or the need to upgrade capacity, that module may be removed and replaced without disturbing the mounted external enclosure or the unit's wiring connections. Due to the internal module being in a NEMA 4X enclosure, replacement and upgraded modules are quick and easy to install, with a greatly mitigated risk of damage from the installer. After disconnecting power, the installer must simply attach the encased module to the mount and connect the wires to the terminal block.

#### Rotary Disconnect Option



The two separate surge modules within this unit and the modular nature of this design allow for continued redundant protection in the event one of the modules fails. When the failed surge module is removed from the unit, the unit may be re-energized and continue to operate on the remaining module. This greatly reduces the downtime of protection while waiting for a replacement module and keeps your facility protected.

The modules use advanced Thermally Protected Metal Oxide Varistors. They come in a variety of voltage and phase configurations. Each module houses dual LED status lights, Form "C" dry contact relays, and an Audible Alarm with a silence switch. Module A is equipped with an externally viewable Surge Counter.

This unit utilizes a terminal block connection that allows for a connection range from #10AWG to 2/0. It is available with a rotary disconnect option.

#### Features:

- Modular Design - 400kA, 500kA, & 600kA/phase available
- Dual Module Protection
- UL 1449 Fourth Edition Listed
- Available in UL 1449 Type 1 or Type 2 Configurations
- Sine Wave Tracking: UL 1449 Type 2  
UL 1283 Listed
- Audible Alarm with a Disable Switch
- Per Phase Dual LED Status Indication
- Externally Viewable Surge Counter on Module A
- Form C Dry Contacts

- NEMA 4 Steel Unit with NEMA 4X encased modules installed inside
- 20kA Inominal
- 200kA SCCR
- Lifecycle tested to 12,000 10kA Impulses
- All modes of protection
- Thermally Protected MOVs
- Multiple MOV technology featuring large and robust MOVs
- Equidistant and symmetrical surge pathways for a true surge capacity rating
- 10 Year Warranty



## T45 Modular Surge Protective Device 400kA - 600kA per Phase

General Technical Specifications	
Connection Type	Parallel, Terminal Lugs - #10AWG - 2/0 AWG Disconnect - #10AWG - 1/0
Voltage, Phase Configuration	120/208V Three Phase Wye, (4W+G)* (127/220V Three Phase Wye, (4W+G))* (220/380V Three Phase Wye, (4W+G)** 277/480V Three Phase Wye (4W+G)** 240V Three Phase Delta (3W+G) 480V Three Phase Delta, (3W+G)
Maximum Continuous Operating Voltage	120V, 150 VAC (125%); 127V, 150 VAC (118%); 220V, 320 VAC (145%); 240V, 320 VAC; 277V, 320 VAC; 480V, 550 VAC; All Others 115%
Surge Capacity	200 kA/Mode, 400kA/Phase 250 kA/Mode, 500kA/Phase 300 kA/Mode, 600kA/Phase
Short Circuit Current Rating (SCCR)	200kAIC
Protection Modes	All Modes: L-N, L-L, L-G, N-G
Operating Frequency Range	47 - 63 Hz
UL 1449 Location Type	Type 1 (SPDs intended for Line or Load Side of Main Disconnect) or Type 2 (Intended for Load Side of Main Disconnect)
UL 1449 Nominal Discharge Current (In)	20 kA
Standards	UL 1449 4th Edition, CSA, UL 96A Lightning Protection Master Label compliant
Status Indication	Dual Colored LEDs, Audible Alarm, Form C Relay, Surge Counter
Enclosure	NEMA 4, 12, & 13 Rated
Dimensions	16" x 16" x 6.8"
Weight	34.7 lbs
50 Ohm EMI/RFI Attenuation	-50 db max(Type 2), -45db max(Type 1); from 10 kHz to 100MHz. The system provides up to 120dB insertion loss from 100 kHz to 100 MHz when used in a coordinated facility system.
Response Time	<0.5 nanoseconds
Operating Temperature	-40°C to +75°C
Operating Humidity	0% to 95% non-condensing
Warranty	10 Years

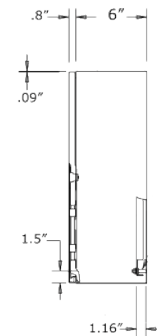
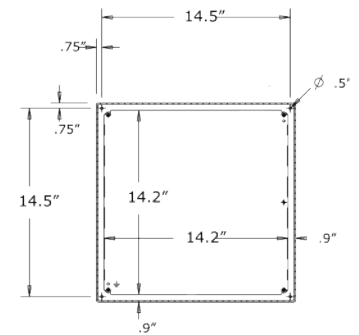
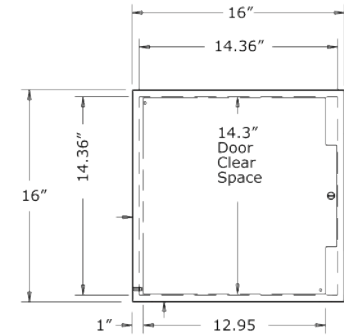

\*This is a 120/208V unit, and can be used in 127/220V applications

\*\*This is a 277/480V unit, and can be used in 220/380V applications



## T45 Modular Surge Protective Device 400kA - 600kA per Phase

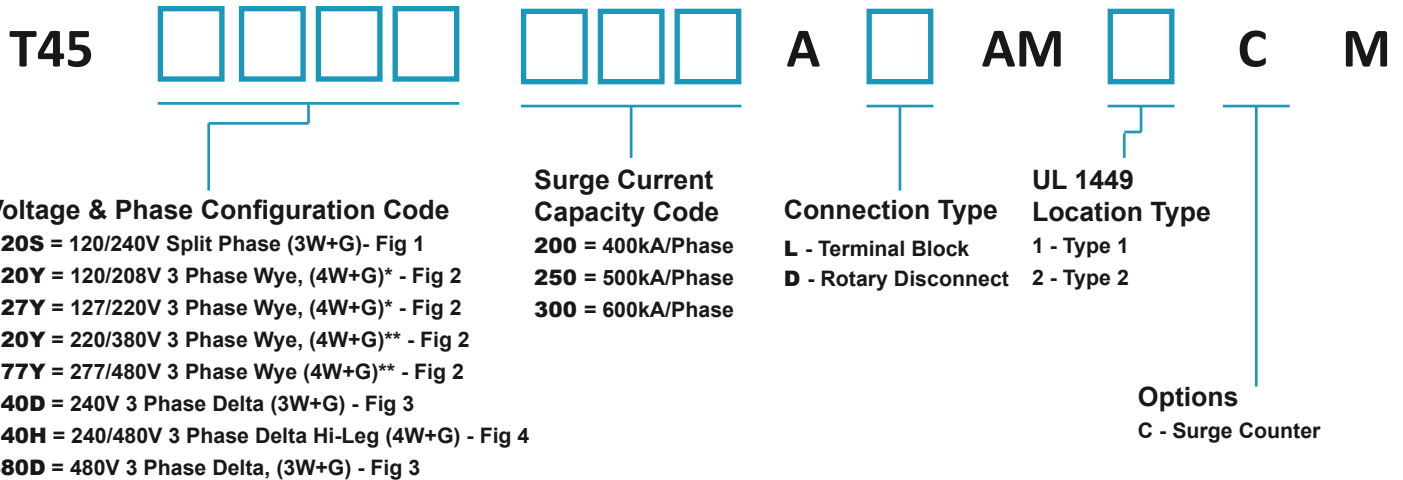

\*This is a 120/208V unit, and can be used in 127/220V applications

\*\*This is a 277/480V unit, and can be used in 220/380V applications

You may place the order as either part number.

### Example Product number:

Filled in:

Complete:

T45 120Y 300 A L AM 1 C M = T45120Y300ALAM1CM

**Fig. 1**

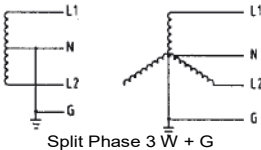

**Fig. 2**

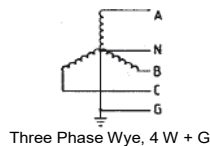

**Fig. 3**

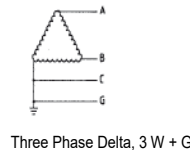

**Fig. 4**

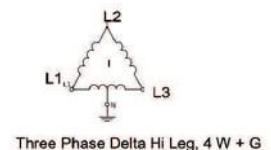

### System Voltage Compatibility

Model Voltage/Phase Code	Nominal System Voltages	System Configuration	MCOV	I <sub>n</sub>	SCCR	UL 1449 Voltage Protection Rating			
						L-N	L-G	N-G	L-L
<b>120S</b>	120/240	Split Phs, 3W+G	150	20kA	200kA	700	700	700	1200
<b>120Y</b>	120/208; 127/220	3 Phs Wye, 4W+G	150	20kA	200kA	700	700	700	1200
<b>127Y</b>	120/208; 127/220	3 Phs Wye, 4W+G	150	20kA	200kA	700	700	700	1200
<b>220Y</b>	220/380; 240/415; 277/480	3 Phs Wye, 4W+G	320	20kA	200kA	1000	1000	1000	1800
<b>240L</b>	240	Single Phs, 2W+G	320	20kA	200kA		1200		1200
<b>240H</b>	240/480	3 Phs Delta Hi-leg, 4W+G	320/550	20kA	200kA	1200/1800	1200/1800	1200	2000/3000
<b>277Y</b>	220/380; 240/415; 277/480	3 Phs Wye, 4W+G	320	20kA	200kA	1000	1000	1000	1800
<b>240D</b>	220; 230; 240	3 Phs Delta, 3W+G	320	20kA	200kA		1200		1200
<b>480D</b>	380; 400; 415; 440; 460; 480	3 Phs Delta, 3W+G	550	20kA	200kA		1800		2000



## T1 2-Pair Dataline Surge Protective Device Modular Pluggable DIN

### DIN Mount Dataline SPD Base and Surge Module

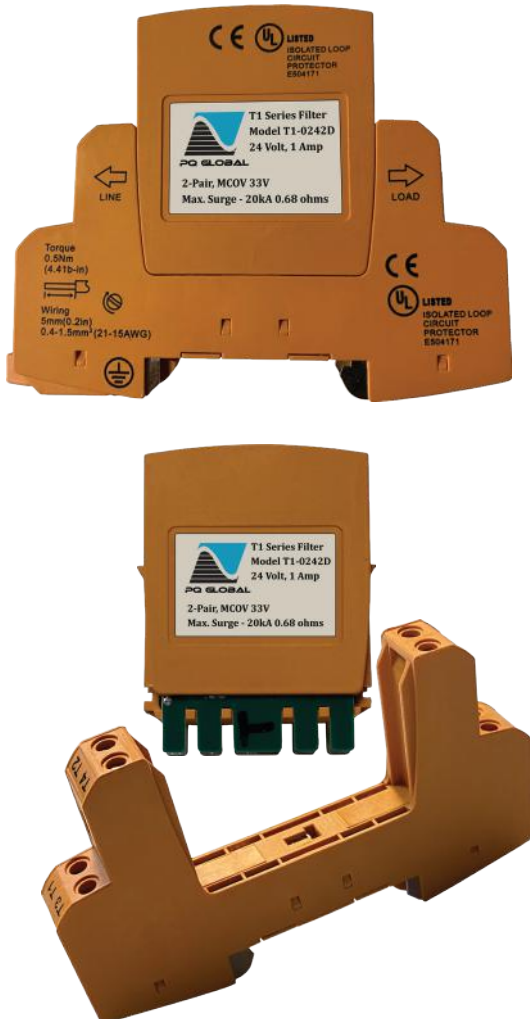

This is the T1 2-Pair Dataline Surge Protective Device.

The T1 2-Pair (4-Line) Dataline Protector is a surge protection device available in 5V, 12V, 24V, and 48V configurations. Its modular design allows modules to be exchanged without the need for removal of the base and without interruption of the signal transmission. This module model is for two pairs, or four lines, with a common reference potential in the system. It is suitable for use in ANSI/IEEE C62.41 Category B or C locations, as well as upstream directly at or near the protected device.

This unit is designed for mounting on a 35mm DIN rail. The base uses screw terminals to secure each wire on the load and line sides.

It has a three-stage protection circuit using gas discharge tubes and diodes to protect from surges and mitigate transients. Each unit has a 1-year warranty.

This device is suitable for protecting data or signal transmissions from transients, voltage spikes, and surges that may travel through communication lines. Sensitive equipment on data or signal lines can be easily disrupted and damaged from transients without a device to divert excess energy to ground.

This is a UL497b listed surge suppressor. Suitable for use from 0-20mA, 4-20mA current loops, TTY 4-20mA, TTY, TTL, V24 RS232C, and high-frequency transmission systems

RS485 surge protection, suitable to use for 4-20 mA current loops, analog/digital communication, RS485, RS422 (V11) interface, high-frequency bus system and two wires video transmission systems.

This SPD has screw terminal connections, and ground through DIN.

### Key Specs:

- **Operating Voltage:** 5V, 12V, 24V, or 48V DC
- **Operating Current:** 1 Amp
- **UL497 Compliant**
- **IEC61643-21:2012 cat D1/C1/C2/C3 Compliant**
- **4-20mA RS485/RS232/Modbus Signal Input Surge Protection**
- **Connection:** Series; Screw Terminals

### Features:

- **DIN Rail Mountable Base** with grounding potential
- **Modular Design** - Modules can be exchanged without removing the base or disrupting signals
- **Pluggable Surge Protection**
- **Three-Stage Protection Circuit**
- **1 year warranty**

Rev 25.09.21-1.6



## T1 2-Pair Dataline Surge Protective Device Modular Pluggable DIN

General Technical Specifications	
Connection Type	Series
Protection Line	2 pairs (4 Lines)
Series Impedance per line	0.68 Ohm
Nominal Voltage	5V, 12V, 24V, 48V
Lightning Impulse Current (10/350µs) per line	2.5kA
Maximum Continuous Operating Voltage (VDC/VAC)	5V, 6 / 4.2; 12V, 15 / 10.6; 24V, 33 / 23.3; 48V, 54 / 38.1
Maximum Discharge current (8/20µs) per line	20kA
Protection Modes	All Connected Modes: L-L, L-PG
Cutoff Frequency	100 MHz
C2 Nominal discharge current(8/20µs) per line	10kA
Nominal Current	1 Amp
Connection	Screw Terminals, Ground connection through DIN
C2 Voltage Protection L-L & L-PG 8/20µs	5V: ≤ 30 12V: ≤ 45 24V: ≤ 55 48V: ≤ 100
C3 Voltage Protection L-L & L-PG 1KV/µs	5V: ≤ 24 12V: ≤ 38 24V: ≤ 48 48V: ≤ 75
Enclosure	Thermoplastic, UL49 V-0 Rated
Standard Compliance	UL497b; IEC 61643-21:2012
Response Time	<0.5 nanoseconds
Operating Temperature	-40°C to +85°C
Mounting	35mm DIN-rail
Weight	0.14 lbs
Size: in/(mm)	2.9" x 3.5" x 0.47" /(74 x 90 x 12) (H x W x D)
Warranty	1 Year

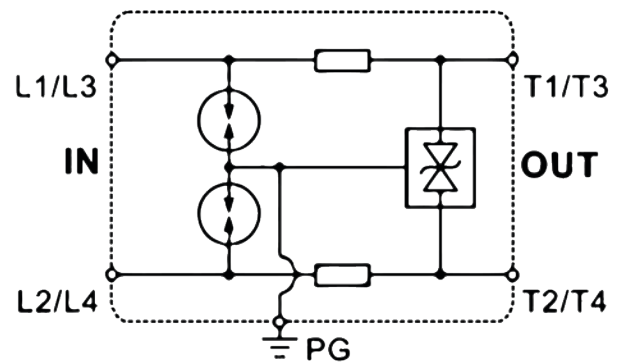
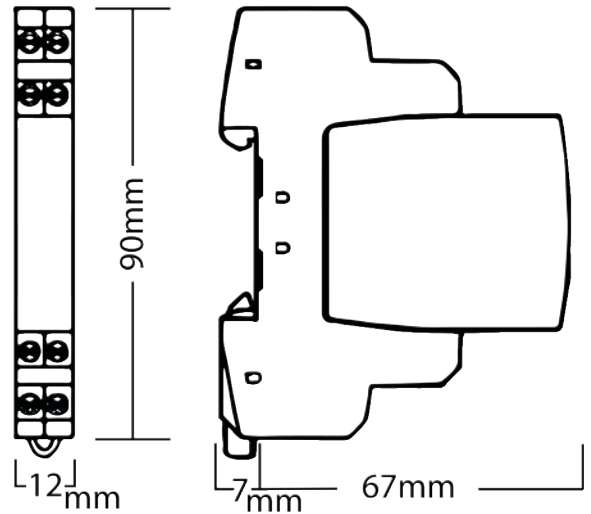

**T1**



**Voltage Configuration Code**

**005** = 5V DC  
**012** = 12V DC  
**024** = 24V DC  
**048** = 48V DC



**# of Pairs**

**1** = 1-Pair  
**2** = 2-Pair



**Mount**

**D** - DIN

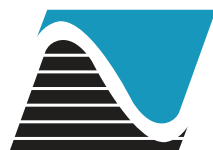

## T2 AC Noise Filter & Surge Protective Device 50kA per Phase

### Finger Safe Terminal Block AC Noise Filter & Surge Protective Device 25kA/Mode, 50kA/Phase



This is the T2 AC Noise Filter and Surge Protective Device. The SPD has a 50kA per Phase surge current capacity.

This filter has a 5.75" x 3.25" x 1.875" enclosure with integrated external mounting flanges. The terminal blocks on this model are internal, offering a finger safe installation and reduction of electrical exposure to unintended contact.

The T2 Filter offers status indication with a single LED; when illuminated, it indicates the unit is operational.

This filter has a multi-stage hybrid design. The noise mitigation and surge protective stages work in a coordinated array that allows disruptive impulses that would bypass a standard clamping device to be attenuated. The T2 uses advanced Thermally Protected Metal Oxide Varistors, inductors, and capacitors, which allows this device to achieve a more comprehensive protection of sensitive equipment in demanding applications.

High-frequency noise and ringing transients generated by lightning, utility switching, or an internal operation can significantly impact your sensitive equipment. These power anomalies can easily disrupt your critical processes or degrade and damage sensitive microprocessor-driven equipment.

Low-energy transients and high-frequency noise events are responsible for both disruption and long-term degradation of sensitive microprocessor driven equipment. A complete power protection strategy should include installation of a high frequency noise/surge filter at the input of your most critical equipment as well as at the output of known disruptive devices.

This filter has 18-10AWG terminal connections.

#### Key Specs:

- **Operating Voltage:** 120, 240, or 277 VAC
- **Operating Current:** 5, 10, 15, 20, 30 Amps
- **EMI Attenuation**
- **Surge Capacity:**  
25kA/mode, 50kA/Phase
- **Connection:** Series; Terminal Block

#### Features:

- **Multi-stage hybrid design;** Inductor, Capacitor, Thermally Protected MOV
- **LED Status Indication:** Monitors all protected modes
- **Finger Safe** Internal Terminal Blocks
- **5 year warranty**



## T2 AC Noise Filter & Surge Protective Device 50kA per Phase

General Technical Specifications	
Operating Voltage	120, 240, or 277 VAC
Maximum Operating Current	5A, 10A, 15A, 20A & 30A
Maximum Continuous Operating Voltage (MCOV)	120V, 150 VAC; 125% 240V, 320 VAC; 115% 277V, 320 VAC; 115%
Peak Surge Current Rating	25 kA/Mode, 50 kA/Phase
Connection Type	Series, Input/Output; 18-10AWG Terminal Connections
Clamping Voltage	340 VAC
Operating Frequency Range	47 - 63 Hz
EMI Attenuation	Up to 70 dB typical from 25kHz to 2MegHz
Protection Modes	All Connected Modes: L-N, L-G, N-G
Technology	Hybrid technology featuring thermally protected MOVs, Inductors and Capacitors
Standards: <b>Designed and tested to:</b>	UL 1449 4th Edition Recognized SPD, Type 2 Component Assembly, CSA 22.2, UL 1283 Rec. Filter
Status Indication	Green LED
Dimensions (in/mm)	1.875"(H) x 3.25" (W) x 5.75" (L) (47.6 x 82.6 x 146.1 mm)
Weight (lb/kg)	12 oz (.34 kg)
Operating Temperature	-40°C to +85°C
Operating Humidity	0% to 95% non-condensing
Warranty	5 Years

### Wiring Connections

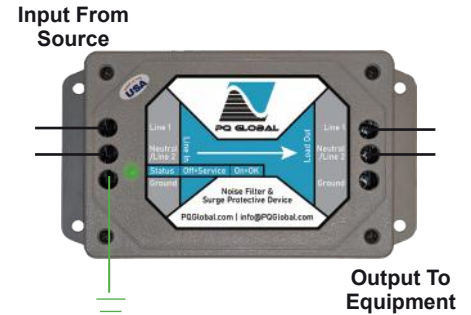

### Mounting

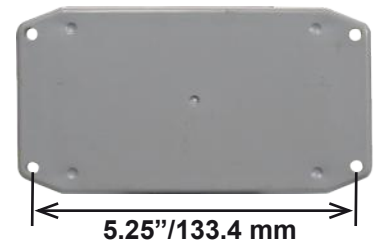

### T2F

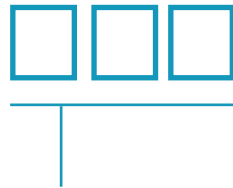

#### Voltage & Phase Configuration Code

**120** = 120V Single Phase (2W+G)

**240** = 240V Single Phase (2W+G)



#### Load Capacity

**05** = 5 Amps

**10** = 10 Amps

**15** = 15 Amps

**20** = 20 Amps

**30** = 30 Amps



#### Connection Type

**T** - Terminal Block



## T2-FD SLAC - AC Series Surge Filter with Data/Signal Line Surge Protection

### T2-FDSLAC Surge Filter & Data/Signal Protection 25kA/Mode, 50kA/Phase

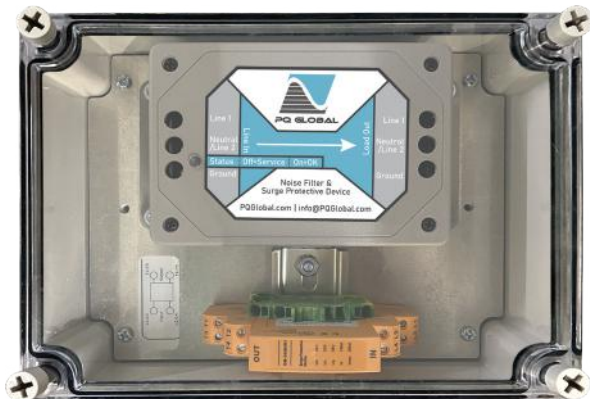

### DIN Mount Dataline/Signal-line SPD Base and Surge Module



This is the T2-FD SLAC AC Series Surge Filter with a Data/Signal-Line surge protection device. These protective devices are mounted together inside one enclosure, offering power and communication protection in one package.

The AC Series Surge Filter is available in 120V, 240V, or 277V configurations and with 5A, 10A, 15A, 20A, or 30 Amp ratings. The Data/Signal Line Protection is available as 1-Pair (two lines) or 2-Pair (4 lines) and in 5V, 12V, 24V, or 48V DC configurations. The Dataline component is DIN mounted inside of the enclosure adjacent to the surge filter.

The terminal blocks on this model are internal, offering a finger-safe installation and reduction of electrical exposure to unintended contact.

The T2 Filter offers status indication with a single LED; when illuminated, it indicates the unit is operational.

The AC SPD has a 50kA per Phase surge current capacity.

This filter has a multi-stage hybrid design. The noise mitigation and surge protective stages work in a coordinated array that allows disruptive impulses that would bypass a standard clamping device to be attenuated.

The Dataline protector has a removable surge module, leaving the base, wiring, and data/signal flow uninterrupted during a module change. The data lines are connected by screw terminals.

The Dataline SPD has a three-stage protection circuit using gas discharge tubes and diodes to protect from surges and mitigate transients. This device is suitable for protecting data or signal transmissions from transients, voltage spikes, and surges that may travel through communication lines.

#### Key Specs - Filter:

- **Operating Voltage - Filter:** 120, 240, 277 VAC
- **Operating Current - Filter:** 5, 10, 15, 20, 30 Amps
- **EMI Attenuation:** Up to 70dB from 25kHz to 2MegHz
- **Surge Capacity:** 25kA/mode, 50kA/Phase
- **Finger Safe Internal Terminal Blocks**
- **Connection:** Series; Terminal Block

#### Key Specs - Dataline:

- **Operating Voltage - Dataline:** 5V, 12V, 24V, 48V DC
- **Operating Current - Dataline:** 1 Amp
- **Three-stage protection circuit**
- **Modular Design - Effortless module changes**
- **35mm DIN Rail Mount - With grounding**
- **UL497b Listed, RS485 Compliant**

Rev 25.09.23-1.3



## T2-FD SLAC - AC Series Surge Filter with Data/Signal Line Surge Protection

### AC Noise Filter & Surge Protective Device

General Technical Specifications	
Operating Voltage	120, 240, 277 VAC
Maximum Operating Current	5A, 10A, 15A, 20A & 30A
Maximum Continuous Operating Voltage (MCOV)	120V, 150 VAC; 125% 240V, 320 VAC; 115% 277V, 320 VAC; 115%
Peak Surge Current Rating	25 kA/Mode, 50 kA/Phase
Connection Type	Series, Input/Output; 18-10AWG Terminal Connections
Clamping Voltage	340 VAC
Operating Frequency Range	47 - 63 Hz
EMI Attenuation	Up to 70 dB typical from 25kHz to 2MegHz
Protection Modes	All Connected Modes: L-N, L-G, N-G
Technology	Hybrid technology featuring thermally protected MOVs, Inductors and Capacitors
Standards: <b>Designed and tested to:</b>	UL 1449 4th Edition Recognized SPD, Type 2 Component Assembly, CSA 22.2, UL 1283 Rec. Filter
Status Indication	Green LED
Dimensions (in/mm)	1.875"(H) x 3.25" (W) x 5.75" (L) (47.6 x 82.6 x 146.1 mm)
Weight (lb/kg)	12 oz (.34 kg)
Operating Temperature	-40°C to +85°C
Operating Humidity	0% to 95% non-condensing
Warranty	5 Years

### Wiring Connections

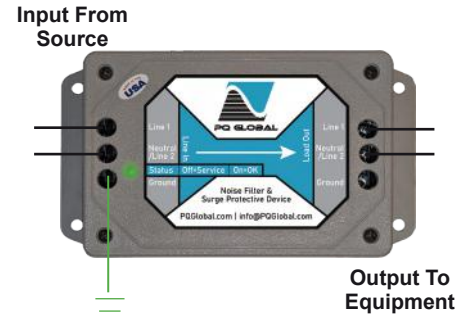

### Mounting

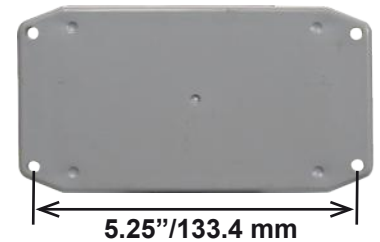

### AC Surge Filter

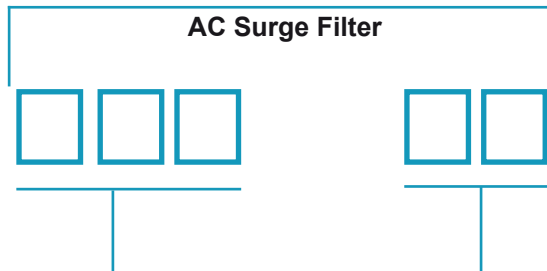

### Dataline SPD

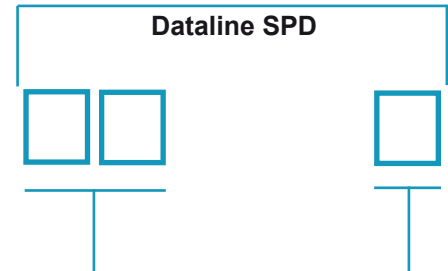

## T2-FD

FD - Filter & Data

Voltage & Phase Configuration Code

**120** = 120V Single Phase (2W+G)  
**240** = 240V Single Phase (2W+G)

Load Capacity

**05** = 5 Amps  
**10** = 10 Amps  
**15** = 15 Amps  
**20** = 20 Amps  
**30** = 30 Amps

Voltage Configuration Code

**05** = 5V DC  
**12** = 12V DC  
**24** = 24V DC  
**48** = 48V DC

# of Pairs

**1** = 1-Pair  
**2** = 2-Pair

Rev 25.09.23-1.3



## T2-FD SLAC - AC Series Surge Filter with Data/Signal Line Surge Protection

### DIN Mount Dataline/Signal-line SPD

General Technical Specifications	
Connection Type	Series
Protection Line	1 pair (2 Lines) or 2 pairs (4 Lines)
Series Impedance per line	0.68 Ohm
Nominal Voltage	5V, 12V, 24V, 48V
Lightning Impulse Current (10/350µs) per line	2.5kA
Maximum Continuous Operating Voltage (VDC/VAC)	5V, 6 / 4.2; 12V, 15 / 10.6; 24V, 33 / 23.3; 48V, 54 / 38.1
Maximum Discharge current (8/20µs) per line	20kA
Protection Modes	All Connected Modes: L-L, L-PG
Cutoff Frequency	100 MHz
C2 Nominal discharge current(8/20µs) per line	10kA
Nominal Current	1 Amp
Connection	Screw Terminals, Ground connection through DIN
C2 Voltage Protection L-L & L-PG 8/20µs	5V: ≤ 30 12V: ≤ 45 24V: ≤ 55 48V: ≤ 100
C3 Voltage Protection L-L & L-PG 1KV/µs	5V: ≤ 24 12V: ≤ 38 24V: ≤ 48 48V: ≤ 75
Enclosure	Thermoplastic, UL49 V-0 Rated
Standard Compliance	UL497b; IEC 61643-21:2012
Response Time	<0.5 nanoseconds
Operating Temperature	-40°C to +85°C
Mounting	35mm DIN-rail
Weight	0.14 lbs
Size: in/(mm)	2.9" x 3.5" x 0.47" / (74 x 90 x 12) (H x W x D)
Warranty	1 Year

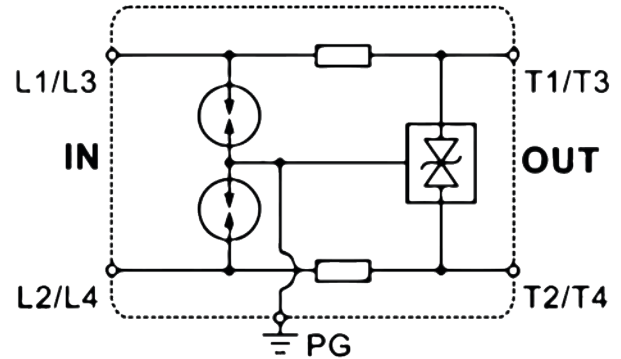
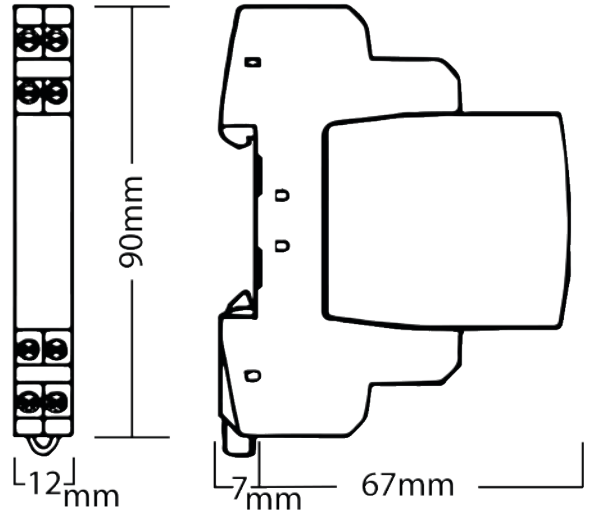

Rev 25.09.23-1.3



## T2 Line Reactor Series



The T2 Line Reactor is part of the Tier 200 series product line. It is a three-phase 3% or 5% impedance line reactor factory-installed in a NEMA 1 steel enclosure, providing a complete, ready-to-install solution for harmonic mitigation and equipment protection. Designed for industrial and commercial power quality applications, it reduces low-frequency harmonic distortion while extending the service life of connected equipment.

### Protection & Performance Benefits

Installed in series with your electrical system, the line reactor delivers multiple protective functions that improve both power quality and equipment longevity:

**Harmonic Reduction** – Attenuates low-frequency harmonics generated by variable frequency drives and other non-linear loads, reducing distortion fed back to the supply network

**Inrush Current Limiting** – Controls starting currents and commutation effects, reducing stress on upstream electrical infrastructure and downstream equipment

**Voltage Transient Dampening** – The added system impedance helps bridge minor voltage dips and limit peak currents, providing a buffer against power quality disturbances

**Extended Equipment Life** – By smoothing current waveforms and reducing electrical stress, the reactor helps protect motors, drives, and other connected loads from premature wear

### Industrial Construction

Each unit is built to order in a painted steel NEMA 1 enclosure sized appropriately for the application. Terminal block connections provide straightforward series installation. Enclosures for higher-amperage units include ventilation provisions to ensure adequate heat dissipation under full load conditions. Also available with a lug kit connection.

### Flexible Sizing & Custom Configurations

Standard configurations are available from 20A through 200A. Custom amperage ratings, enclosure modifications, and application-specific requirements are available upon request.

### Standards & Warranty

cURus Recognized, cULus Listed  
RoHS Compliant  
EN 61558-2-20 / IEC 61558-2-20  
5-Year Manufacturer Warranty



## T2 Line Reactor Series

Line Reactor Specifications	
Connection Type - Line Reactor	Series, Terminal Block or Lug Kit
Maximum Current Capacity	Available in: 20A - 200A (or custom)
Impedance/Inductance	High Impedance 3% or 5% available
Maximum Heat Dissipation	Dependent on the size of the line reactor
Insulation Class	Dependent on the size of the line reactor
Short Circuit Current Rating (SCCR)	22kAIC
Enclosure	NEMA 1 Steel
Dimensions	Dependent on the amperage
Weight	Dependent on the amperage
Standards	cURus, CULus, IEC 61558-2-20/EN 61558-2-20
Operating Temperature	-40°C to +75°C
Operating Humidity	0% to 95% non-condensing
Warranty	5 Years

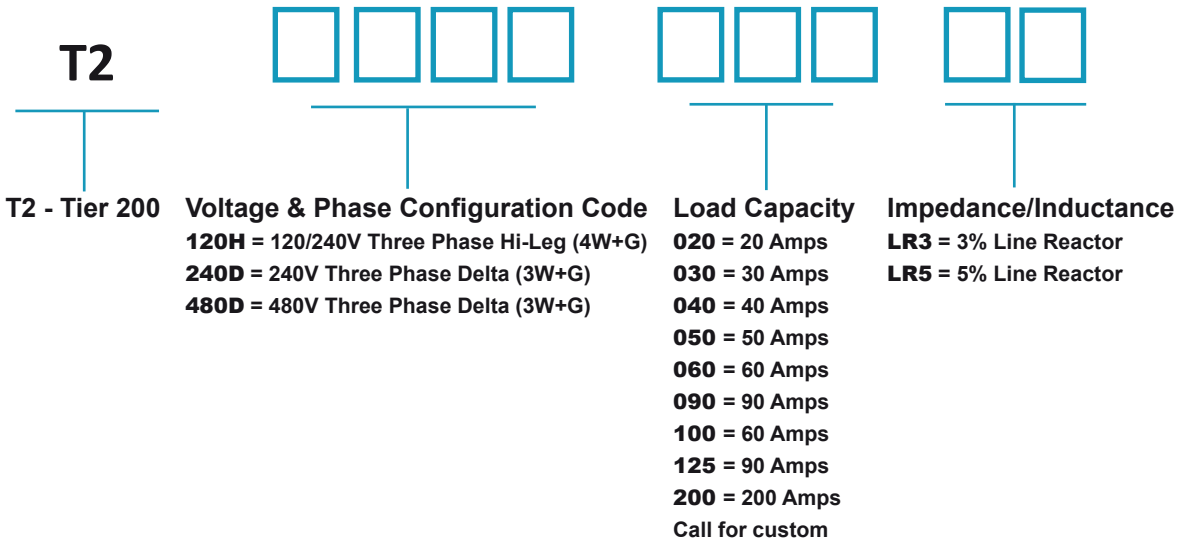

Example Model Number: T2-480D100LR3

Rev 26.01.16-1.1



## T2-45 Surge Reactor Series Surge Protection and Line Reactor



The T2-45 Surge Reactor is a Tier 200 series comprehensive protection system designed to safeguard critical equipment from the full spectrum of power quality disturbances. By integrating three protective technologies in a single enclosure, it delivers complete coverage for equipment operating in harsh electrical environments.

### Complementary Protection Technology

The system combines a UL 1449 5th Edition listed Type-2 Surge Protective Device with an integrated UL 1283 electromagnetic interference (EMI) filter and a line reactor. Each component addresses specific power quality threats:

- **Surge Protective Device (parallel connection)** – Provides rapid clamping action against high-energy transient overvoltages from lightning strikes, switching events, and utility disturbances
- **EMI Filter** – Attenuates high-frequency noise and electromagnetic interference that can disrupt sensitive electronics
- **Line Reactor (series connection)** – Mitigates harmonic currents, limits inrush currents and transient voltage spikes, and provides protective impedance that enhances overall system performance

### The Protective Overlap Advantage

The integration of these technologies creates a multi-stage filtering system with complementary protection characteristics. The series line reactor and integrated EMI filter work together to progressively attenuate electrical disturbances across a broad frequency spectrum—from low-frequency harmonics through high-frequency electromagnetic interference. Meanwhile, the parallel-connected SPD provides rapid protection against high-energy transient overvoltages.

Each component enhances the others: the line reactor's impedance improves the SPD's ability to handle repetitive transients, the SPD protects against voltage spikes, and the EMI filter addresses high-frequency noise throughout the system. This synergistic design delivers comprehensive protection that individual devices cannot achieve alone.

All protective elements are factory-integrated into a single, ready-to-install unit housed in a NEMA 1 rated enclosure. The Surge Reactor is available in multiple configurations to precisely match your system requirements, with enclosure dimensions and technical specifications tailored to each application.

Rev 26.01.16-1.1



## T2-45 Surge Reactor Series Surge Protection and Line Reactor

Surge Protective Device Specifications	
Connection Type - SPD	Pre-wired - Parallel, Wire Lead - #12 AWG
Voltage, Phase Configuration	120/208V Three Phase Wye, (4W+G)* (127/220V Three Phase Wye, (4W+G))* (220/380V Three Phase Wye, (4W+G))* 277/480V Three Phase Wye (4W+G)* 240V Three Phase Delta (3W+G) 480V Three Phase Delta, (3W+G)
Maximum Continuous Operating Voltage	120V, 150 VAC (125%); 127V, 150 VAC (118%); 240V, 320 VAC; 220V, 320 VAC (145%); 277V, 320 VAC; 480V, 550 VAC; All Others 115%
Surge Capacity	25 kA/Mode, 50kA/Phase
50 Ohm EMI/RFI Attenuation	-50 db max(Type 2); from 10 kHz to 100MHz. The system provides up to 120dB insertion loss from 100 kHz to 100 MHz when used in a coordinated system.
Protection Modes	All Available Modes: L-N, L-L, L-G, N-G
Operating Frequency Range	47 - 63 Hz
Response Time	<0.5 nanoseconds
UL 1449 Location Type	Type 2 (Intended for Load Side of Main Disconnect)
UL 1449 Nominal Discharge Current (In)	20 kA
Status Indication	Status LEDs: Blue(or Green) = OK, Red = Replace
Line Reactor Specifications	
Connection Type - Line Reactor	Series, Terminal Block or Lug Kit
Maximum Current Capacity	Available in: 20A - 200A (or custom)
Impedance/Inductance	High Impedance 3% or 5% available
Maximum Heat Dissipation	Dependent on the size of the line reactor
Insulation Class	Dependent on the size of the line reactor
General Technical Specifications	
Short Circuit Current Rating (SCCR)	22kAIC
Enclosure	NEMA 1 Steel
Dimensions	Dependent on the size of the line reactor
Weight	Dependent on the size of the line reactor
Standards	UL 1449 5th Edition, CSA, UL 96A Lightning Protection Master Label compliant, UL1283 cURus, CULus, UL506, CSA 22.2, IEC 61558-2-20
Operating Temperature	-40°C to +75°C
Operating Humidity	0% to 95% non-condensing
Warranty	SPD:10 Years ; Line Reactor: 5 Years

\*If ordering a Wye configuration ensure you have a neutral running to the protected equipment\*  
Consult the factory for custom configurations

Rev 26.01.16-1.1



## T2-45 Surge Reactor Series Surge Protection and Line Reactor



### T2-45 Surge Reactor Series Product Number Ordering Guide

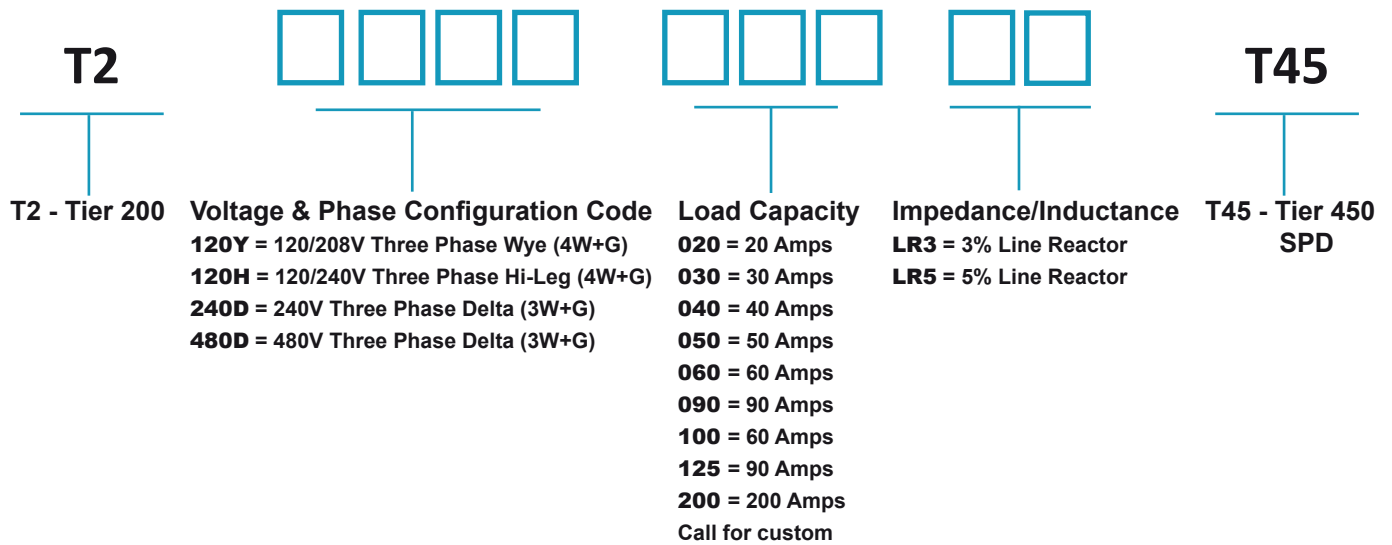

Example Model Number: T2-480D100LR3-T45



## Medium Voltage Digital Monitoring Panel



The Power Quality Monitoring Panel is a low- or medium-voltage measurement device that revolutionizes safety for technicians and personnel. The Monitoring Panel provides a digital display that allows for the measurements of voltage, current, power, and frequency without the need to use a meter and test leads.

This device requires separate connections for voltage and current; both are connected in parallel. This device is available in Medium-Voltage configurations, up to 5000V, or Low Voltage configurations up to 600V.

The Monitoring Panel takes the line voltage and reduces it 100:1 to a safer level where they can be monitored without the need for excessive personal protective equipment. There is one conductor per phase for the voltage connection. Connections can be made at the source, the connected device, or on the line anywhere in between. The metrics for the voltage can be read on the digital display, where it will show the real-time actual values. Additionally, they can be read with a meter by using test leads and the available voltage taps on the Monitoring Panel at their reduced values; you must use the reduction ratios to calculate the full line reading.



This system also measures current with the use of current transformers. The factory default is 200:5 current transformers for the medium voltage unit, but the system is USB programmable for user-defined transformers. One transformer is required per phase. If using solid-core transformers, in order to feed it through the center of the current transformer, it will require the conductor to be disconnected from either the source or the connected device. The metrics for current can be read on the digital display, where it will show the real-time actual values. Just like with voltage, there are taps provided to manually read current with a meter and test leads, and it will require the use of the current ratio to calculate the actual value.

The Medium Voltage Monitoring Panel will remain on, active, and monitoring, even if the monitored equipment is disconnected from the power. It requires a separate low-voltage power connection for the digital display to function; 25 ft leads with a 0.5" conduit hub are provided. The Low Voltage Monitoring Panel is self-powered from the connected voltage, and the display will turn off if the power is disconnected.

All standard Medium Voltage Power Quality Monitors will ship with 3 Solid-Core 200:5 Current Transformers—for a custom configuration, please consult your sales representative.

Note: Current Transformers are polarity sensitive, H1(Line side) must face the source, or the polarity will be reversed.

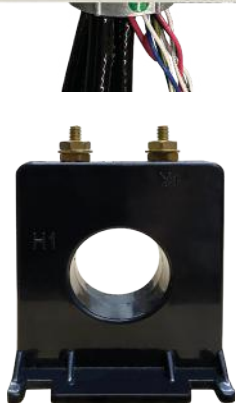

Medium Voltage Digital Model



## Medium Voltage Digital Monitoring Panel

Voltage Measuring	
• Voltage Input Range:	0 - 5000V
• Operating Frequency:	0 - 400Hz
• Input Impedance:	500k Ohm
• Input Load:	2 Watts
• Manual Voltage Test Point Ratio:	100:1
Current Measuring	
• Manual Current Test Point Ratio:	200:5
• Standard CT Current Ratio:	200:5
• Standard Solid CT Inner Diameter:	1.13"
• Standard CT Dimensions:	2.68" x 2.5" x 2.00"
• Standard CT Mounting Dimensions:	1.75" x 1.75"
General Technical Specifications	
• Connection Type:	8 ft #10 AWG 10kV w/ Shield Wire Leads For Voltage 10 ft Twisted #14 for Current
• Digital Display Measurements:	Voltage, Current, Power, kWh, Frequency
• Remote Programming:	USB-A Port
• Remote Monitoring:	Modbus Through Externally Accessible RJ45 Connection
• Power Requirements:	Externally Powered Display 600VAC - 277VAC; 25ft Remote Power Leads Included 0.5" Conduit Hub
• Accuracy:	+/- 1% @ 55°C
• Main Conduit Hub	2" Diameter
• Communications Conduit Hub	1" Diameter
• Enclosure:	NEMA 4X Polycarbonate
• Enclosure Dimensions (body):	10" x 8" x 6" (H x W x D)
• Total Footprint:	12.50" x 10.25" x 7.72"
• Mounting Dimensions (flange):	11.25" x 5.50"
• Operating Temperature:	-40°C to +85°C
• Operating Humidity:	0% to 95% non-condensing
• Country of Manufacture:	United States of America
• Warranty:	3 Years

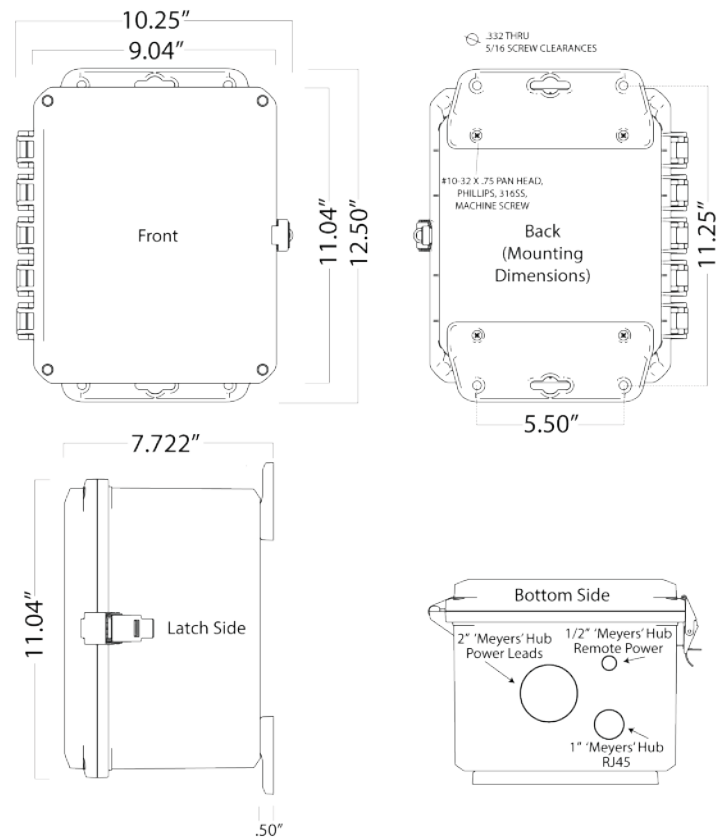
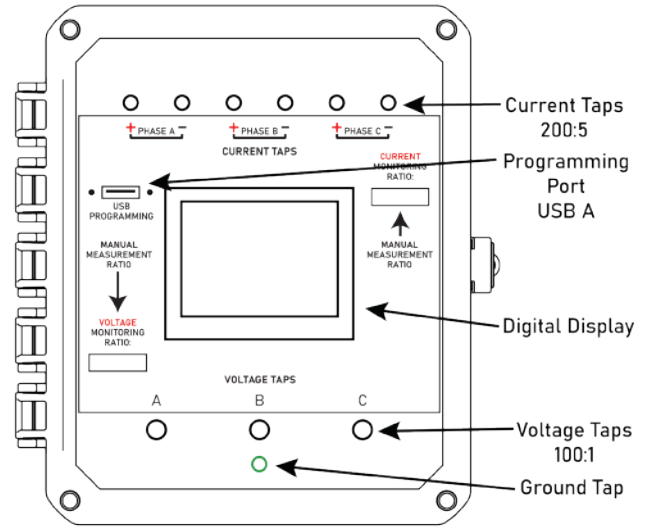

**PQGMP**

**Product Family**  
PQGMP = PQ Global Monitoring Panel



**Voltage**  
MV = Medium Voltage  
LV = Low Voltage



**Monitor**  
D = Digital  
M = Manual

**Example Product Number:**  
PQGMP - MVD

Rev 25.10.29-1.1



## Current Transformer Ordering Information - Standard Offering 200:5 CT

The technical data on this sheet is for our standard 200:5 solid-core current transformers and does not apply to other configurations. The product is not limited to this configuration and can be customer specified; just reflect the necessary "Current Ratio" for your current ratio in the product number ordering information below. If no number is appended to the base Monitoring Panel order, CTs will not be included on low voltage models. If no number is appended to the Medium Voltage model base unit it will come with 3 standard 200:5 solid core CTs.

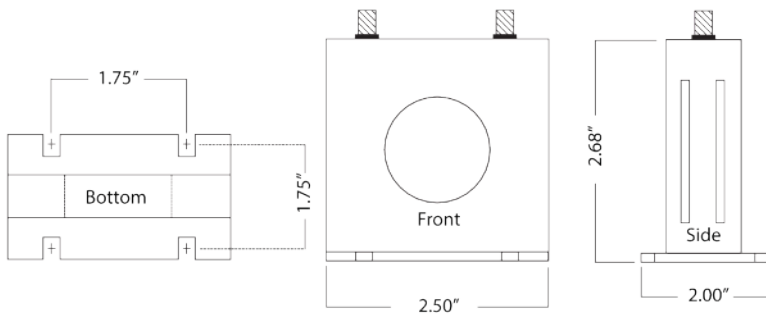

General Technical Specifications - 200:5 CT	
CT Quantity Required For Ziton	3
Current Ratio	200:5
Window Diameter	1.13"
Frequency Range	50Hz - 400Hz
Insulation Voltage	3500 VAC/1min
Accuracy @ 60Hz	± 1%
Thermal Drift	100 PPM/ °C
Installation Category	CAT II
Studs	#8-32
Torque Spec on Studs	10 in/lb.
Pollution Degree	2
Operating Temperature	-20° C to +75° C
Dimensions	2.68" x 2.50 x 2.00"
Mounting Dimensions	1.75" x 1.75"
Standards	UL, CUL, CE, RoHs recognized
Warranty	3 Years

**NOTE: The current transformers are polarity-sensitive! They must be installed with H1 (line side), the lettering on the CTs, facing the source. Improper wiring will result in the reversed polarity of the current reading.**

If the current transformer is not connected to the Monitoring Panel, short the X1 terminal (positive) to the unlabeled terminal X2 (common), since high voltages can be induced in the transformer secondary windings.

Connect the Positive from the Monitoring Panel, the colored (non-white) wire that corresponds to the respective phase, to the X1 (positive) terminal on the CT. Connect the corresponding common white wire to the unlabeled terminal on the CT (X2 - Common).

Remove the short between terminals after wiring.

## CT Ordering Information

Standard Qty 3 x CT 200:5 Amp

Add - **CTxxxx** to the end of product #

Example: Standard 200:5

PQGMP - MVD - **CT02005S**



Product ID

CT = Current Transformer

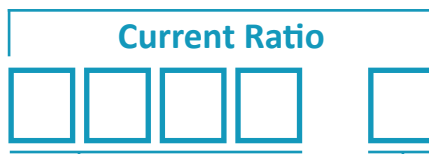

Primary Input

0200 = 200A

XXXX = xxxxA

Secondary Output

5 = 5A



Core Design

S = Solid

P = Split



## Medium Voltage Surge Arrester - 1000V or Greater

### Medium Voltage Surge Arrester



### Interior Status Panel



### Back with Mounting



The Medium Voltage SPD is an industrial-grade surge protection system engineered to safeguard critical medium voltage equipment from damaging transient overvoltages. Originally designed for demanding applications in resource extraction and industrial facilities, it delivers robust protection for systems operating from 1000V through 4160V.

### Core Protection Technology

The system employs parallel-connected surge protection optimized for medium voltage applications:

- **Large and Robust UL Recognized Metal Oxide Varistors (MOVs)** – High-energy varistors engineered to handle the transient currents of medium voltage systems, providing superior surge current capacity and extended service life.
- **Thermally Protected MOVs (TPMOVs)** – Integrated thermal disconnect technology that permanently isolates failed varistor elements, preventing thermal runaway and ensuring continued protection even after component degradation.
- **Parallel Connected with Prewired 10kV Shielded Cable** – Factory-terminated #10 AWG shielded conductors rated for 10kV service, pre-installed with 1.5" conduit hub for streamlined field installation.

### Operational Monitoring & Diagnostics

The system incorporates monitoring features that enable proactive maintenance and fault diagnosis:

- **Isolated Test Points** – Safely accessible test points housed within the enclosure on a dedicated panel behind the door, allowing technicians to verify unit performance without exposure to system level voltages.
- **Per-Phase Manual Status Testing** – Individual phase testing capability enables precise diagnostics and confirmation of protection integrity for each line conductor independently.

### Industrial Construction & Reliability

Built to withstand harsh environments where contamination and environmental exposure can threaten equipment reliability:

- **Potted Internal Components** – Critical surge protection elements are fully encapsulated in protective potting compound, preventing moisture ingress, dust contamination, and chemical exposure that could compromise performance.
- **NEMA 4X Rated Enclosure** – Corrosion-resistant construction provides weatherproof and dusttight protection, suitable for both indoor and outdoor installations in industrial atmospheres.

### Flexible Voltage Configurations

The Medium Voltage SPD is available in multiple voltage ratings to precisely match your system requirements: 1000V, 1500V, 2500V, 3600V, and 4160V. Each configuration is optimized for its specific voltage class, ensuring proper coordination with upstream and downstream equipment while maintaining adequate protection margins.

*Manufacturer Recommends Best Practice of Installing Behind Fusing or a Breaker*

**Unit is not operator serviceable - Do NOT open unit behind Status Panel**  
**Opening unit panel will expose you to high voltages and may result in serious injury or death - standard Shock Hazard labels will be on the unit.**

Rev 26.01.16-1.1

### General Technical Specifications

Connection Type:	Parallel, Pre-wired Wire Lead
Wire Lead Specifications:	8 Ft of 10kV Shielded #10 AWG 1.50" Internally Threaded Conduit Hub
Voltage, Phase Configuration:	1000V, Three Phase Delta, (3W+G) 1500V, Three Phase Delta, (3W+G) 2500V, Three Phase Delta, (3W+G) 3600V, Three Phase Delta (3W+G) 4160V, Three Phase Delta (3W+G)
Maximum Continuous Operating Voltage:	1000V, 1380 VAC (125%); 1500V, 2000 VAC (125%); 2500V, 3400 VAC (125%); 3600V, 4800 VAC (125%); 4160V, 5500 VAC (125%);
Surge Capacity:	50kA/Mode, 100kA/Phase
Short Circuit Current Rating (SCCR):	MOV Components Rated to SCCR 200kAIC
Protection Modes:	All Available Modes: L-L, L-G
Operating Frequency Range :	47 - 63 Hz
Location Type:	Suitable for High Energy Applications Including Category A, B, & C High Energy
Nominal Discharge Current (In):	20 kA
Status Indication:	Isolated test points for each phase
Enclosure:	NEMA 4, 4X, 12, & 13 Rated Polycarbonate Detachable Flange Mounting Bracket Kit Included
Enclosure Size: Mounting:	15.25" x 14.00" x 7.22" (7.72" w/ Feet) (H x W x D) 15.25" x 9.50"
Standards Tested Consistent With:	UL-508A Listed ANSI/IEEE 62.11 IEEE C62.41.2
Response Time:	<0.5 nanoseconds
Operating Temperature:	-40°C to +75°C
Operating Humidity:	0% to 95% non-condensing
Warranty:	5 Years

### Medium Voltage Surge Arrester Dimensional Drawing

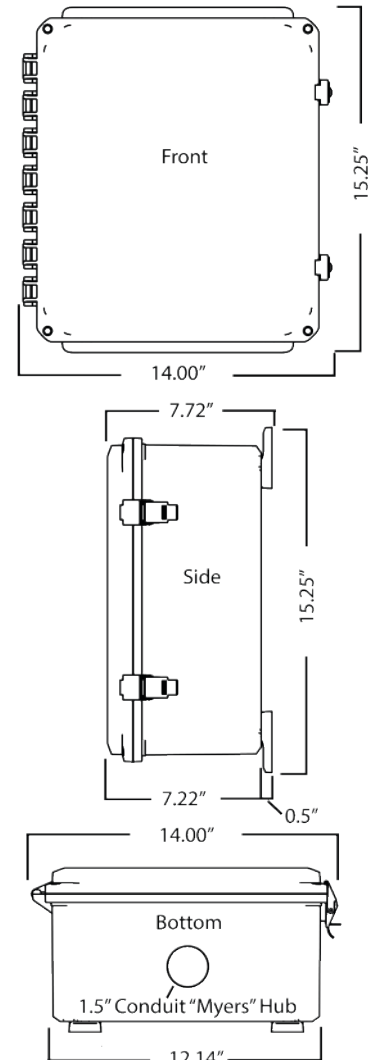

**T65**



**T65 - 650 MVSPD**

**Voltage Code**

**100 = 1000V**  
**150 = 1500V**  
**250 = 2500V**  
**360 = 3600V**  
**416 = 4160V**

**Phase**

**D = Three Phase**  
**Delta**

**Protected Modes**

**A = All Connected Modes**

**Connection**

**W = Wire Lead**

**Status**

**S = Manual Status**

**650 Family Ordering Information: Example Model Number: T65360DAWS**

Rev 26.01.16-1.1

- Based on secondary side of upstream transformer, **NOT** by how load is connected.
- Most SPD order errors are misunderstandings related to grounding or neutrals.
- **Grounded system means that the system is referenced to ground, NOT that there is a safety ground.**
- By convention, ground wires are not 'counted' as one of the wires (3-wire, 4-wire, etc.).

### 3-phase 4-wire Grounded Wye / Neutral Pulled

Neutral bonded to ground.  
Neutral pulled into facility.

V = 120V (208Y/120V)  
V = 277V (480Y/277V)  
V = 347V (600Y/347V)  
V = 127V (220Y/127V)\*  
V = 220V (380Y/220V)\*

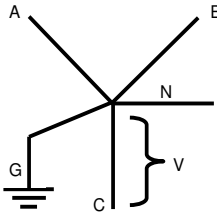

### 3-phase 4-wire Grounded Wye

Neutral bonded to ground. Neutral NOT pulled into facility.

V = 120V (208Y/120V)  
V = 277V (480Y/277V)  
V = 347V (600Y/347V)  
V = 127V (220Y/127V)\*  
V = 220V (380Y/220V)\*

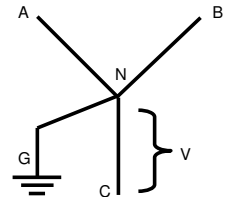

### Resistive or Impedance Grounded Wye

Neutral bonded to ground via grounding resistor. Neutral may, or may not, be pulled into facility.

V = 120V (208Y/120V)  
V = 277V (480Y/277V)  
V = 347V (600Y/347V)  
V = 127V (220Y/127V)\*  
V = 220V (380Y/220V)\*

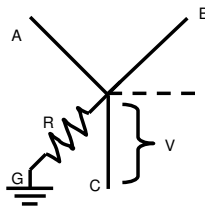

### 3-phase 4-wire Ungrounded Wye

Neutral NOT bonded to ground. Neutral may or may not be pulled into facility.  
Note NEC 285.3(2).

V = 120V (208Y/120V)\*\*  
V = 277V (480Y/277V)  
V = 347V (600Y/347V)  
V = 127V (220Y/127V)\*\*  
V = 220V (380Y/220V)\*\*

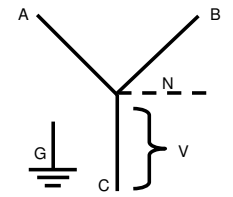

### Split-Phase 'Single-Phase'

Neutral bonded to ground. Neutral usually pulled into facility.

V = 120V (120/240V)  
V = 240V (240/480V)\*\*  
V = 127V (127/254V)\*

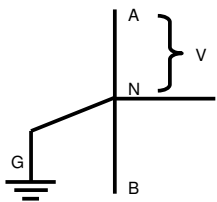

### Single-Phase

Verify where neutral and ground are! Often this is used for one leg or one piece of equipment. Neutral is bonded to ground.

V = 120V  
V = 240V  
V = 277V  
V = 480V\*\*  
V = 127V\*  
V = 220V\*

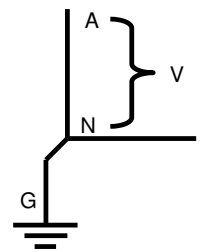

### Hi-Leg Grounded Delta

Neutral bonded to ground. Neutral often pulled into facility.

V = 120/240V  
V = 240/480V\*\*

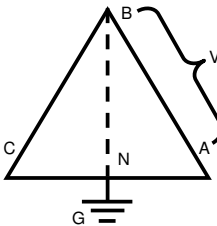

### 3-phase 3-wire Ungrounded Delta

System has NO reference to ground. L-L voltages fixed by transformer, but L-G voltages can vary.

V = 240V  
V = 480V  
V = 600V  
Note NEC 285.3(2)

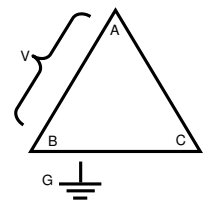

### 3-phase 3-wire Corner Grounded Delta

System has reference to ground because B phase is grounded.

V = 240V  
V = 480V  
V = 600V  
Note NEC 285.3(2)

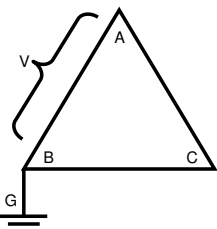

### Open Delta

3-phase 3 or 4-wire. Could be ungrounded, corner grounded or Hi-leg.

Call PQ Global for information.

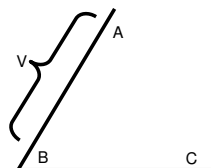

\* non-USA  
\*\* Call PQ Global



# **PQ GLOBAL**

