

PAVEGEN

GENERATING POWER FROM YOUR FOOTSTEPS



FINANCIAL
TIMES

THE
INDEPENDENT

THE TIMES

The
Washington
Post

FOX 5

WIRED

CITYA.M.



NISSAN

Uber

SIEMENS



Sainsbury's

Schneider
Electric

SEAT



UNI QLO

Vikings

Westfield



H&M

L'OREAL

LIDL



Google

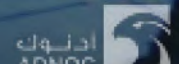

Company

- Over **250** projects in **45** different countries, including **KSA, UAE and Qatar**
- Backed by **Wadi Makkah Ventures**, Tamar Capital and The Hinduja Group and other leading investors



Deployed Globally

250+ Installations 37+ countries.



World Class Team

40+ UK based engineers & technologists



Production & Distribution

UK based with global distribution at a 1000m²/month capacity



Patents Granted

8 global granted patents



Proven Durability

Internal & External (+50°C to -20°C)



Strategic Investors

Wadi Makkah Ventures KSA, The Hinduja Group
Ex CEO of JLL



Technology Applications

Energy storage, custom software development, instantaneous energy

Smart Cities



Muscat, Oman

Public Areas



Washington DC, USA

Urban Parks



Dubai Expo, UAE

Residential Developments



Hong Kong

Key Metrics

- Over **£14m of revenue** generated for Pavegen technology
- In excess of **1000 qualified leads** generated per year from mostly organic leads. 250 leads alone from KSA.
- Increase in **YTD 42%** YoY Sale team activity from inbound leads.
- £14m live pipeline across 50+ active opportunities
- **£800k+** LOI secured (Hong Kong project)
- Multiple projects progressing with Tier 1 global brands and government entities
- **300+ installations across 45+ countries**
- **1 billion+** footsteps captured globally
- Trusted by brands including Google, Toyota, UEFA, and Westfield

Smart Cities



Muscat, Oman

Public Areas



Washington DC, USA

Urban Parks



Dubai Expo, UAE

Residential Developments



Hong Kong



GLOBAL REACH

250+ Installations

Footprint in 45 countries



Improving the world through the power of a human step

Pavegen transforms everyday movement into moments, lighting up public spaces and creating joyful encounters between people and place.

The Telegraph

"The next step in alternative energy supply"

Forbes

"Pavegen wants to become the Tesla of walking"

WIRED

"The best new green energy tech could be right underfoot"

theguardian

"The floor tiles that use foot power to light up cities"

THE HUFFINGTON POST

"Is this the next step for kinetic power?"

Recent news: Global Focus Regions for Pavegen.

Saudi Arabia, USA, SE Asia



Toyota USA Factory install

First People powered Padel court in Mexico

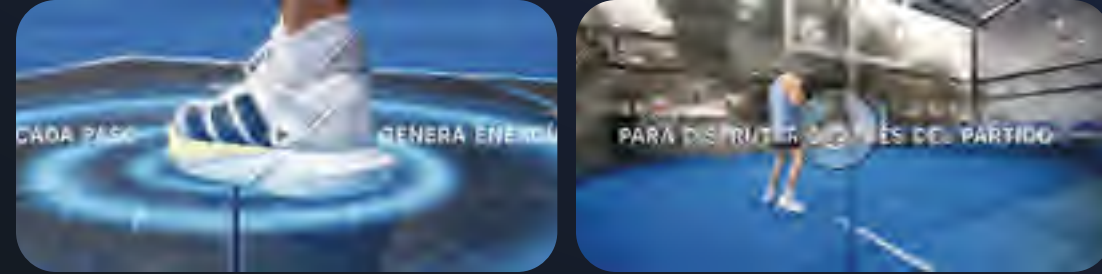

Successful installation at Sport Boulevard with newly established local partnerships



Flagship project successfully completed at Cyberport, Hong Kong (£170k)



Signed £806k Letter of Intent



Success in Saudi Arabia so far: flagship Riyadh project delivered



SPORTS BOULEVARD

RIYADH, SAUDI ARABIA

Pavegen is live with our biggest installation ever in Riyadh. "Thank you and your team for the hard work and tremendous effort in ensuring the full scope of the project was completed ahead of time. Your team's performance has been exemplary, and we look forward to future collaborations."

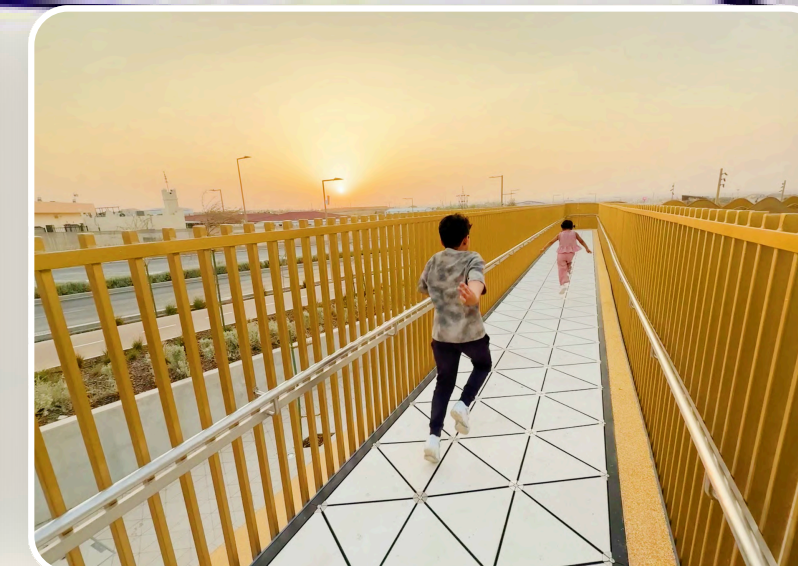

Pavegen CEO strong relationship with Sports Boulevard CEO

Jayne McGivern leads Riyadh's Sports Boulevard, overseeing its development, delivery, and strategy.

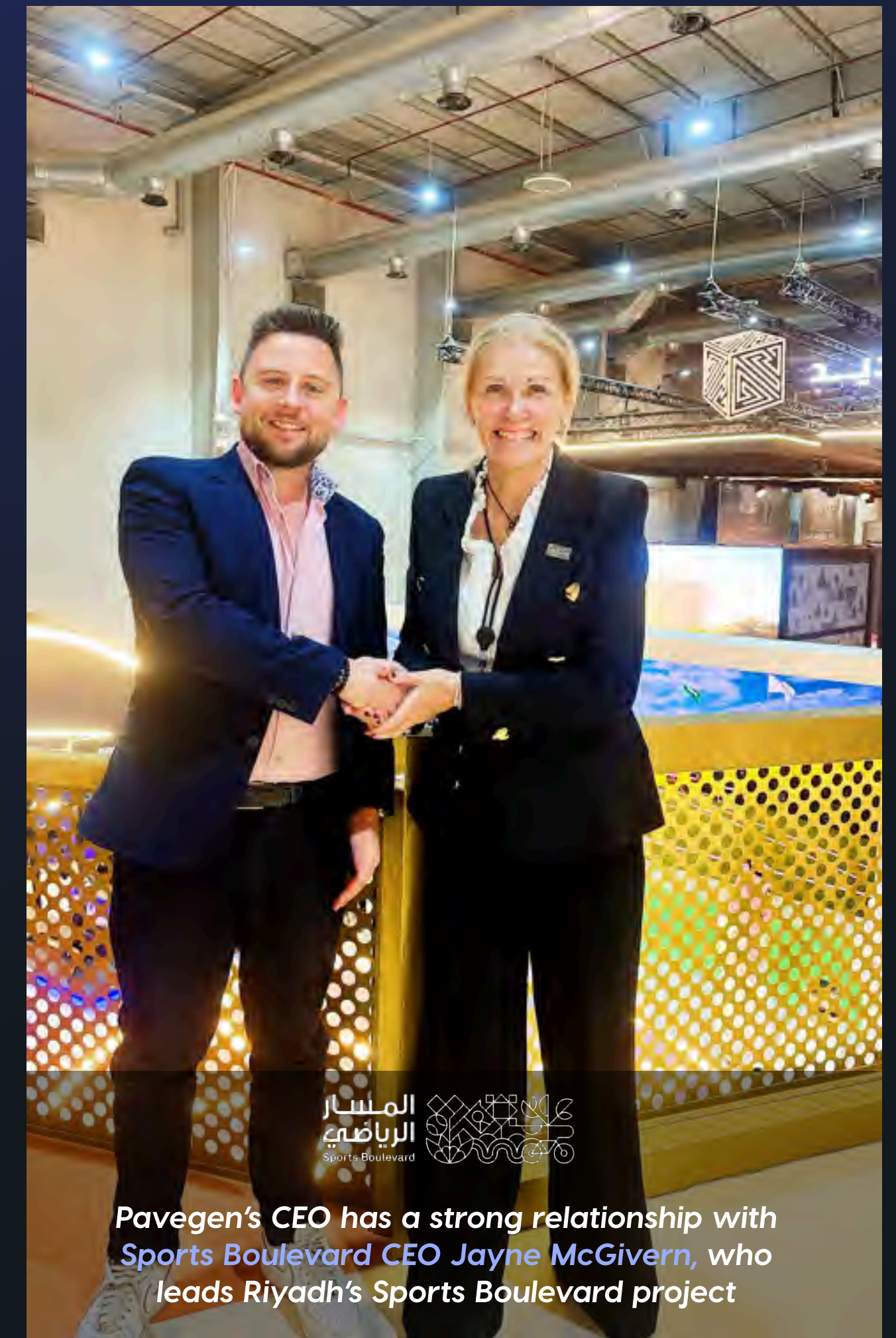
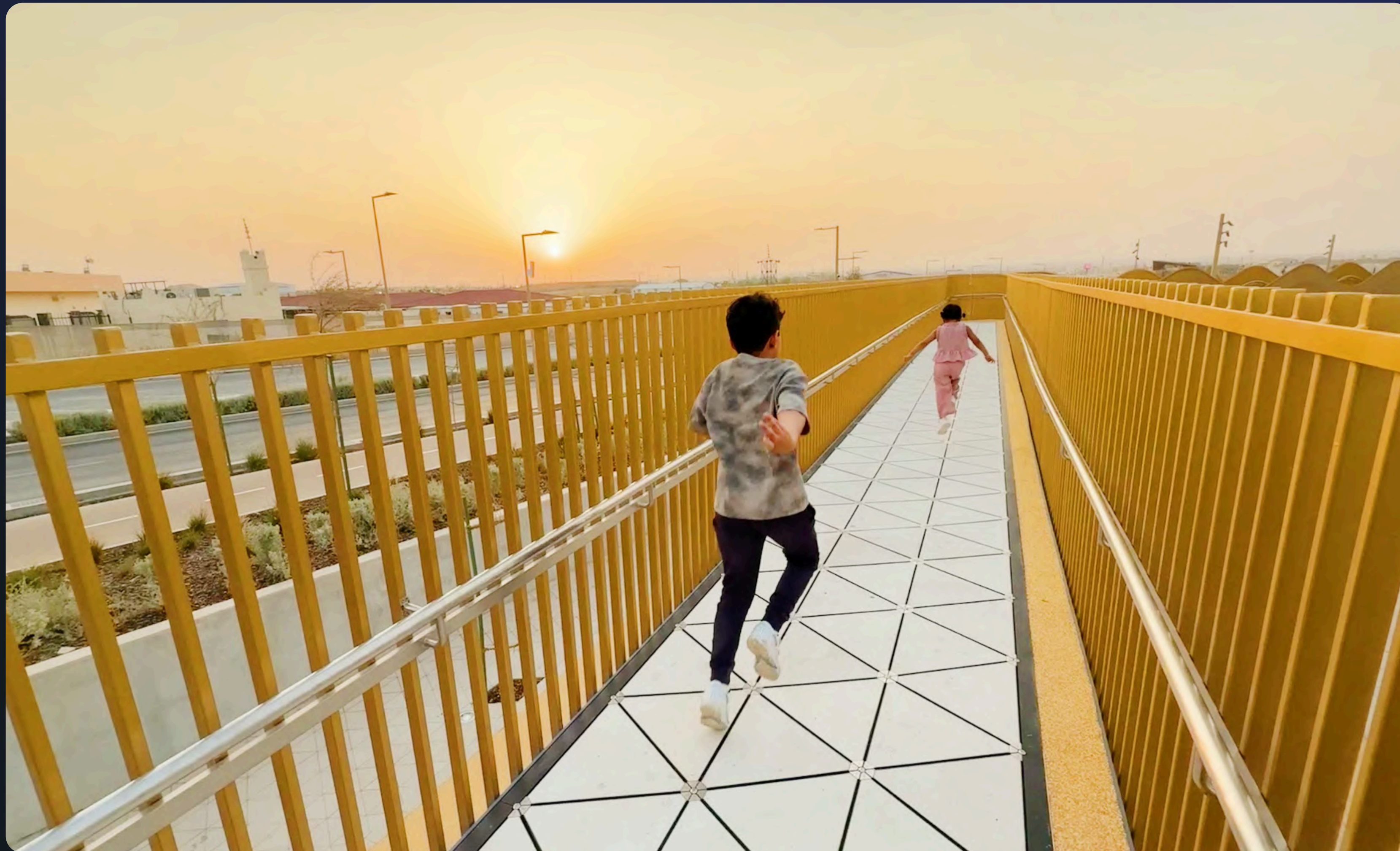

المسار الرياضي Sports Boulevard

Pavegen's CEO has a strong relationship with Sports Boulevard CEO Jayne McGivern, who leads Riyadh's Sports Boulevard project

Product pipeline

We have established a strong brand in the smart city sector. Our market position provides a unique opportunity to release other complementary technologies across vehicle based systems and licensing into industrial use cases

Industrial Uses

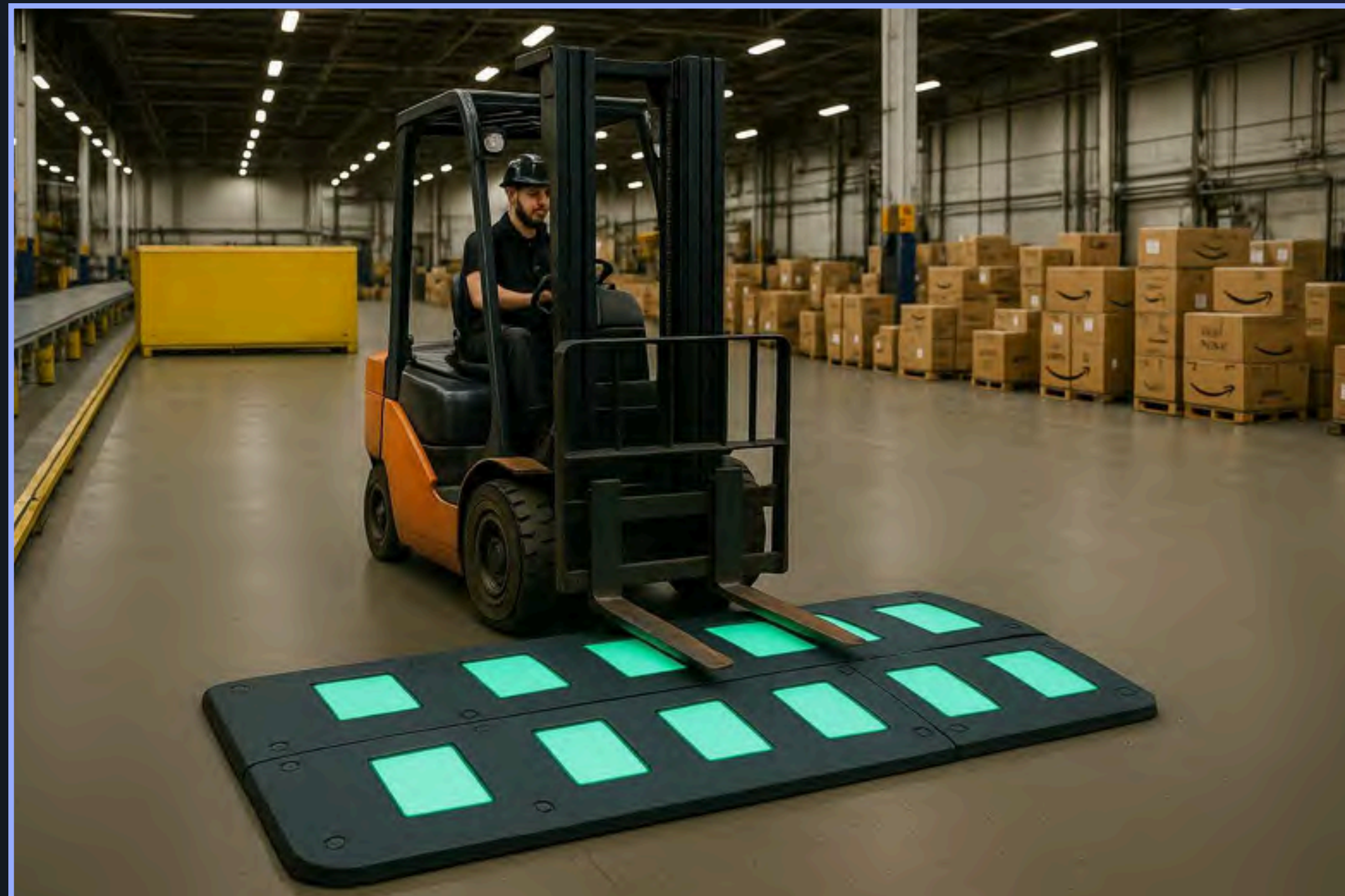

Kinetic Roads



Global Markets

Starting expansion in MENA our roll out will focus on the below sectors. Key markets all ready for using Pavegen technology in their ESG drives. An off grid, sustainable energy source with a software component.



Smart cities and spaces
Investment forecast at \$4.76 Trillion



Events & brand activations
Marketing spend to hit \$3.8 trillion



Transport hubs
Global 2024 Investment = £467B+



Retail
£23.5 trillion

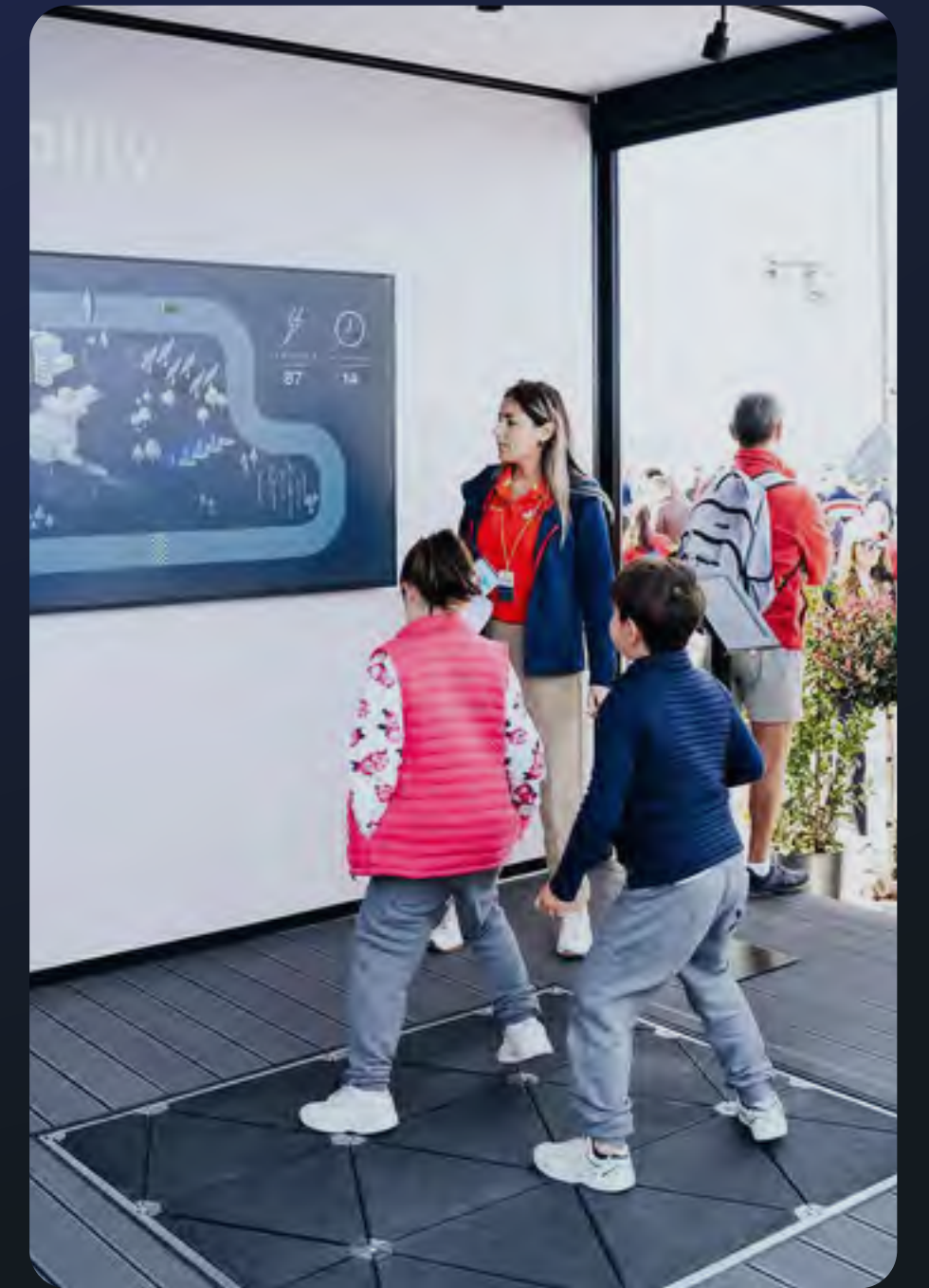

Museums and education
Projected to £1 trillion in 2028

Saudi Arabia Regional Proof

- Secured lead investors **Wadi Makkah** and **Saudi Royal Family**, Due Diligence completed.
- **Flagship POC Installed** - Sports Boulevard Foundation, Riyadh. Pavegen's **largest permanent site globally** (~\$1m)
- Delivered with **Saudi Aramco** (ESG engagement) and **King Faisal Hospital**
- **KSA local factory** feasibility being scoped by lead investors and to be built by Q2 2026
- **Flagship clients ready to deploy** Pavegen tech (King Khalid International Airport, Bank Albilad, Saudi Aramco, Saudi Electricity Company, Jeddah Tower)



المسار الرياضي
Sports Boulevard



وادي مكة
Wadi Makkah Ventures



أرامكو السعودية
saudi aramco

R+D Finished, product ready for Market.

Pavegen Solar+ is a hybrid version of the Pavegen System, combining kinetic and solar energy capture.



Pavegen CEO and Founder - Laurence Kemball-Cook launching Solar Plus to the Middle Eastern market at the Liveable City Summit

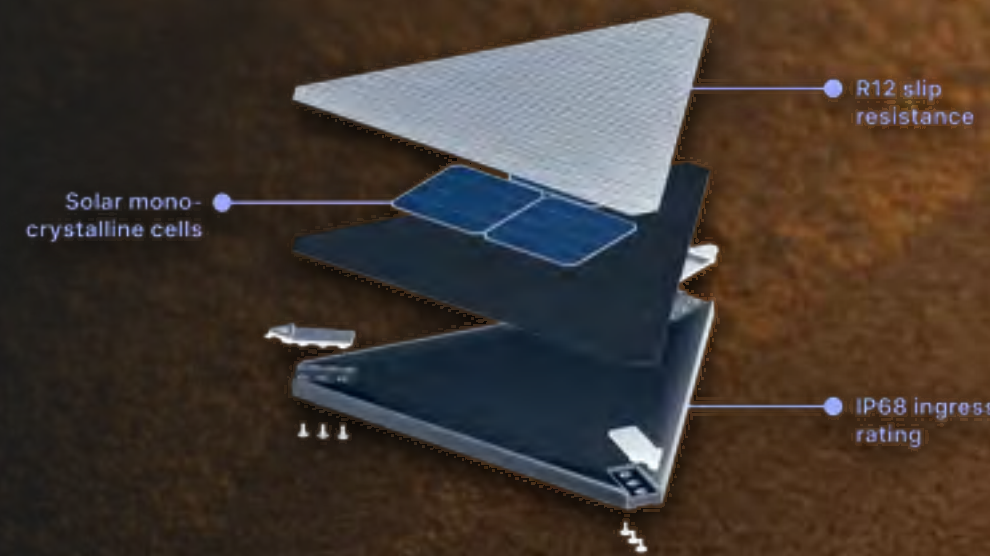
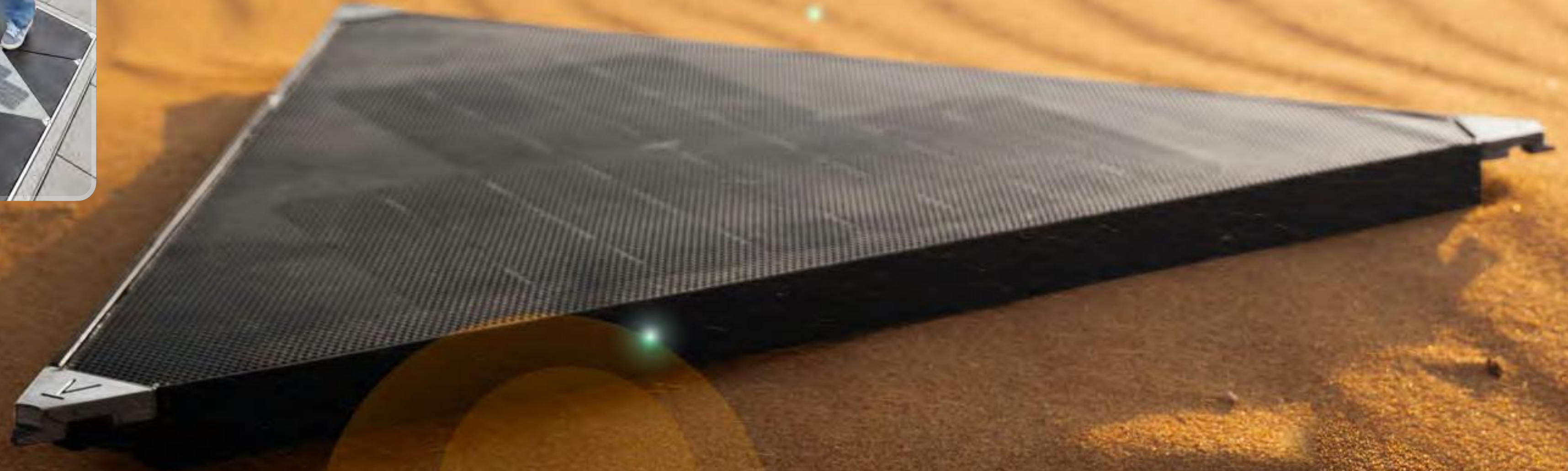

Off Grid power

More energy for higher power consumption applications, off-grid systems and wider energy storage.



Plug and play installation

Our greenest product ever. 30% less embodied energy in its manufacture. With modular, plug-and-play installation.



24/7 continuous power

Unbroken energy generation from the sun in the day and people at night.

Pavegen Solar: Power Walker



The system can sustain 50x 10W lights for 12 hours a day



Energy Generation

Solar Energy



+

Step Energy



→

Street Lighting

Walk to light - Interactive Illuminated Tiles



+

Up to 50 Street Lights



PAVEGEN

Why now

Smart Cities

\$1.06 Trillion

by 2028



AI-Powered Engagement

\$50 Billion+

Emerging market (PwC, WEF)

Cleantech ESG Investment

\$50 Trillion+

by 2025

TAM

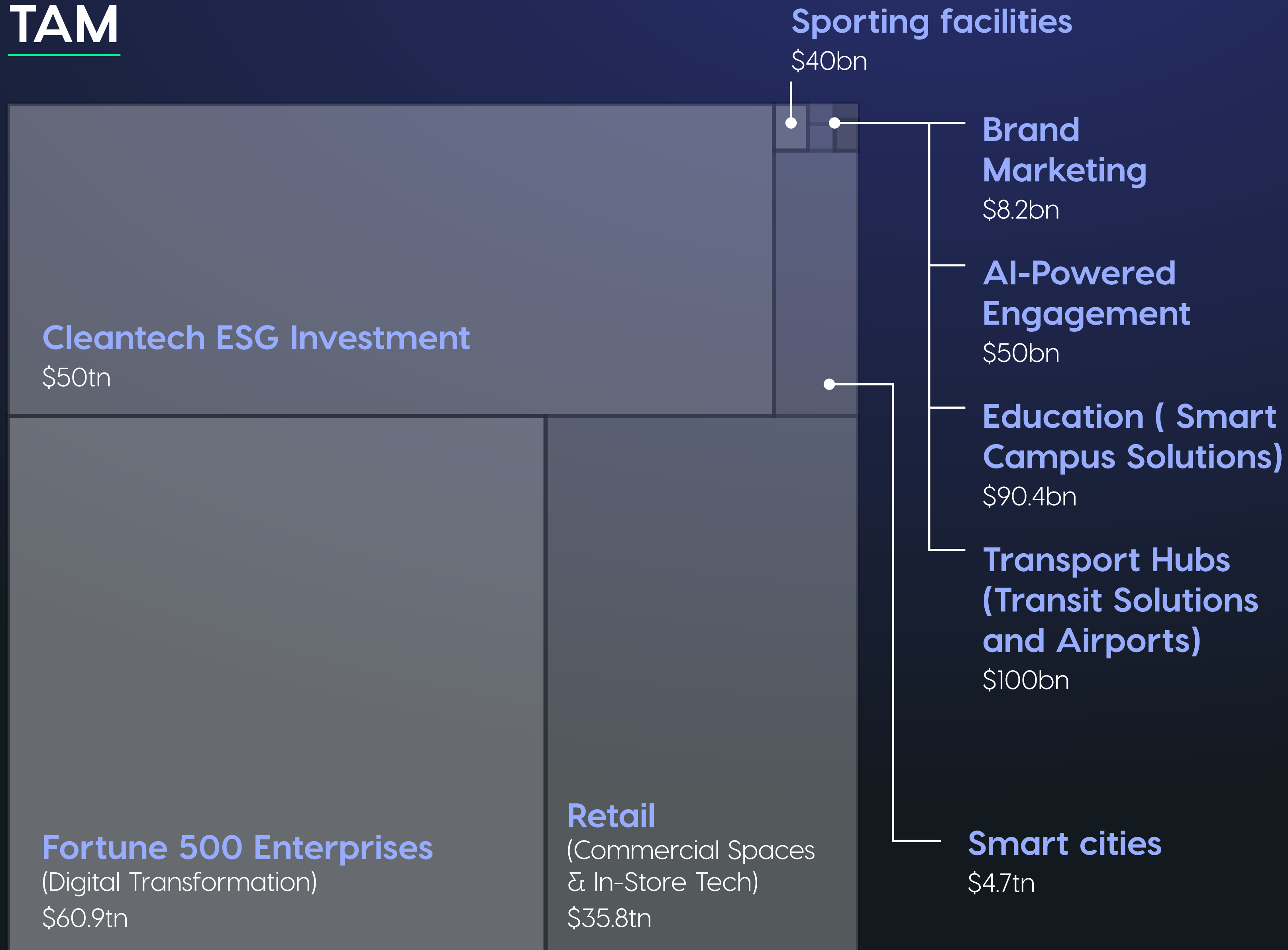

Why Saudi Arabia now?

Saudi Arabia is deploying trillions into high-footfall, experiential infrastructure.

Every major sector (cities, transport, retail, sport) is being rebuilt around:

01 Engagement

02 Data

03 ESG Visibility

- Saudi Arabia is deploying over **\$1 trillion** into next-generation infrastructure and smart cities.
- **\$1.3 trillion** has already been committed to real estate and infrastructure transformation.
- Flagship projects alone exceed **\$20bn–\$500bn** each, creating one of the largest addressable markets globally.



**PAVEGEN SAUDI
ARABIA
EXPANSION
PLANS**



Vision and Context

Saudi Arabia is now in Vision 2030 execution. PIF giga-projects are moving from concept to construction, creating an opportunity to specify Pavegen into flagship destinations and set the benchmark for human-centric smart cities.

With strategic Saudi backing (Wadi Makkah plus Royal Family stakeholders), we are positioned for a long-term KSA commitment through local manufacturing, jobs, and diversification.

2026 to 2030 objectives

- Make KSA our Middle East growth hub and template for a repeatable GCC model
- Get specified across 3+ giga-projects in high-footfall locations
- Build high-margin recurring revenue from data and engagement alongside capex projects
- Launch "Made in Saudi" manufacturing (10,000 sq ft, scalable)
- Scale via a lean team, partners, and tier-one consultants
- Create an exit opportunity, circa £1BN via PIF or a leading regional industrial group



Pavegen's CEO has a strong relationship with Sports Boulevard CEO Jayne McGivern, who leads Riyadh's Sports Boulevard project

Market Traction & Organic Demand (Saudi Arabia)

Strong Product–Market Fit

- Pavegen has achieved global category leadership with proven technology across 45 countries. Momentum is accelerating in MENA, underpinned by Royal family backing and landmark regional contracts.

Leap Finalist 2024, Cityscape Finalist 2024 + 2025

Demand Without Sales Effort:

- 250+ highly qualified inbound leads from Saudi Arabia in the last 12 months
- Generated without local sales presence or regional marketing

Includes:

- Invitations to tender on giga-projects
- Direct engagement from government, developers, architects, and ministries
- Corporate ESG activations and technical specification discussions
- Massive demand for the Solar+ product

Why This Matters:

- This level of unsolicited demand confirms exceptional product–market fit aligned to Vision 2030's infrastructure and experience-led developments, supporting the case for a permanent Saudi base and local capability.



Delivered Projects & Regional Proof

Flagship Saudi Deployment

- Sports Boulevard (Riyadh): Pavegen's largest permanent site globally (~\$1m)
- Delivered with Saudi Aramco (ESG engagement) and King Faisal Hospital

Proven Across the Middle East

- Live installations in Qatar, Oman, UAE (Dubai & Abu Dhabi)
- Demonstrates execution capability at scale across diverse environments

Positioning Saudi Arabia as the GCC hub enables:

- Faster delivery cycles
- Lower logistics costs
- Higher margins, recurring service revenue and long-term institutional contracts

The Middle East is an ideal deployment market:

- High solar exposure
- Dense footfall corridors
- Outdoor, destination-led developments
- Engagement-driven infrastructure investment

Differentiated Platform - Solar+ uniquely combines:

- Kinetic energy + solar generation
- Real-time data + digital engagement
 - Creating a category-defining proposition for governments, giga-projects, banks, transport authorities and real-estate owners.

Current Clients in the Region:



مستشفى الملك فيصل التخصصي ومركز الأبحاث
King Faisal Specialist Hospital & Research Centre

Go To Market Plan - KSA

- Secured lead investors Wadi Makkah and Saudi Royal Family, Due Diligence completed.
- Flagship POC Installed - Sports Boulevard Foundation, Riyadh.
- KSA local factory feasibility being scoped by lead investors and to be built by Q3 2026 with the aim to move HQ to KSA in 2027
- Flagship clients ready to deploy Pavegen tech (King Khalid International Airport, Bank Albilad, Saudi Aramco, Saudi Electricity Company, Jeddah Tower)

Pavegen's Target Clients



Red Sea Project

Regenerative tourism destination focused on sustainability



Diriyah

Advancing Saudi's tourism sector through culture, history, and arts



NEW MURABBA

New Murabba

Aiming to create human-centric spaces and dynamic urban developments



Masar

Creating a modern, distinctive hub in the heart of Makkah



Misk City

Urban development focused on fostering innovation and creativity for Saudi's youth



Qiddiya

376km² site established for innovative and immersive experiences

Competitive advantage

We have built a defensive moat around the business that has accelerated pavegen to product-market-fit. This moat has been built on the following pillars'

RICH GLOBAL PATENT IP PROTECTION

4 patents granted offering wide coverage.

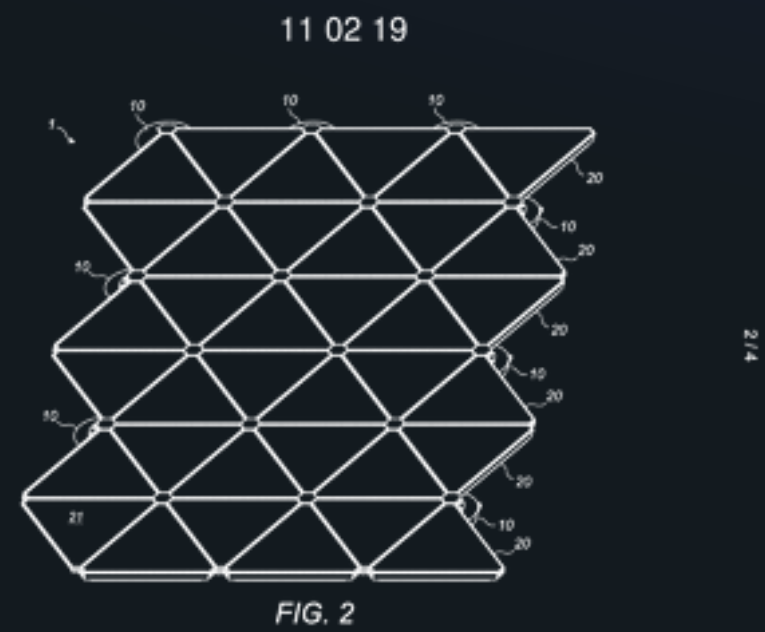
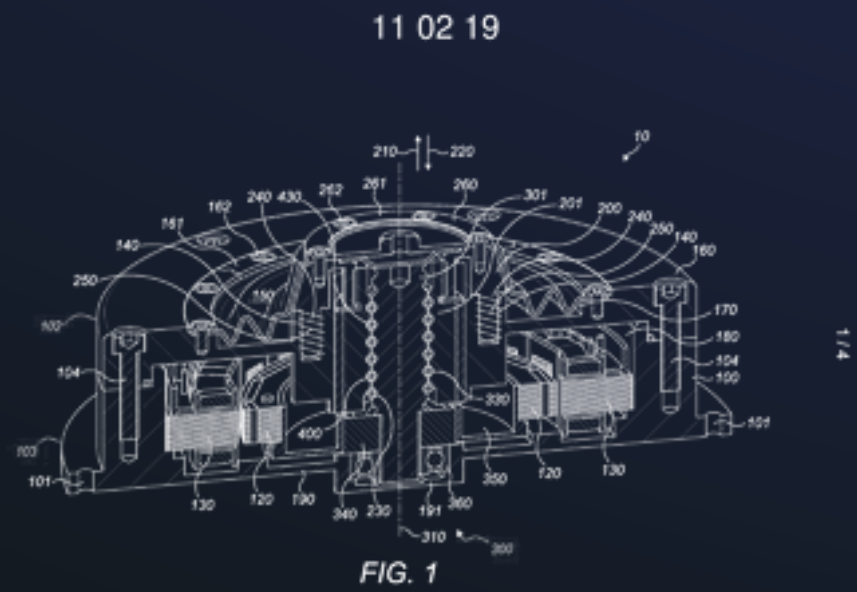

GLOBALLY RECOGNISED BRAND



REPEATABLE BLUE-CHIP CLIENTS

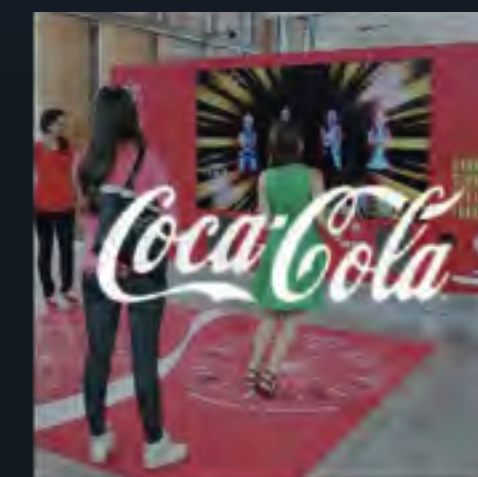
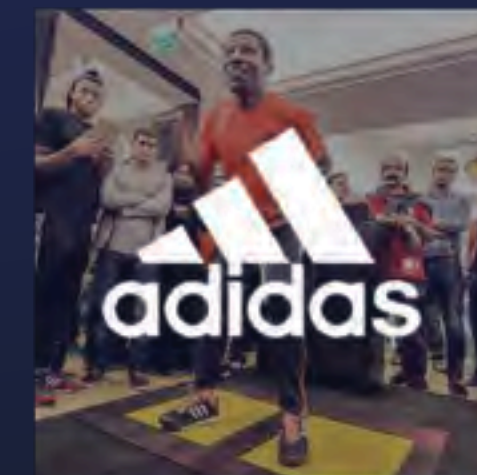
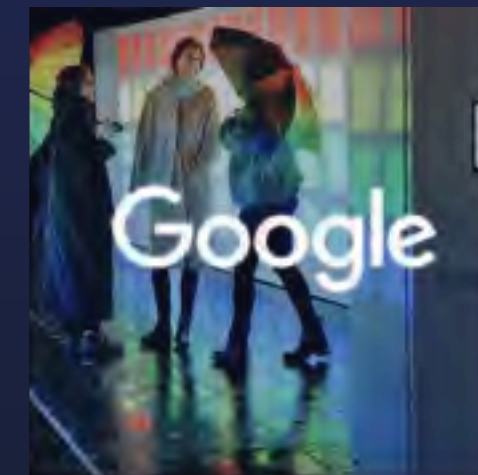

UNRIVALLED CUSTOMER EXPERIENCE

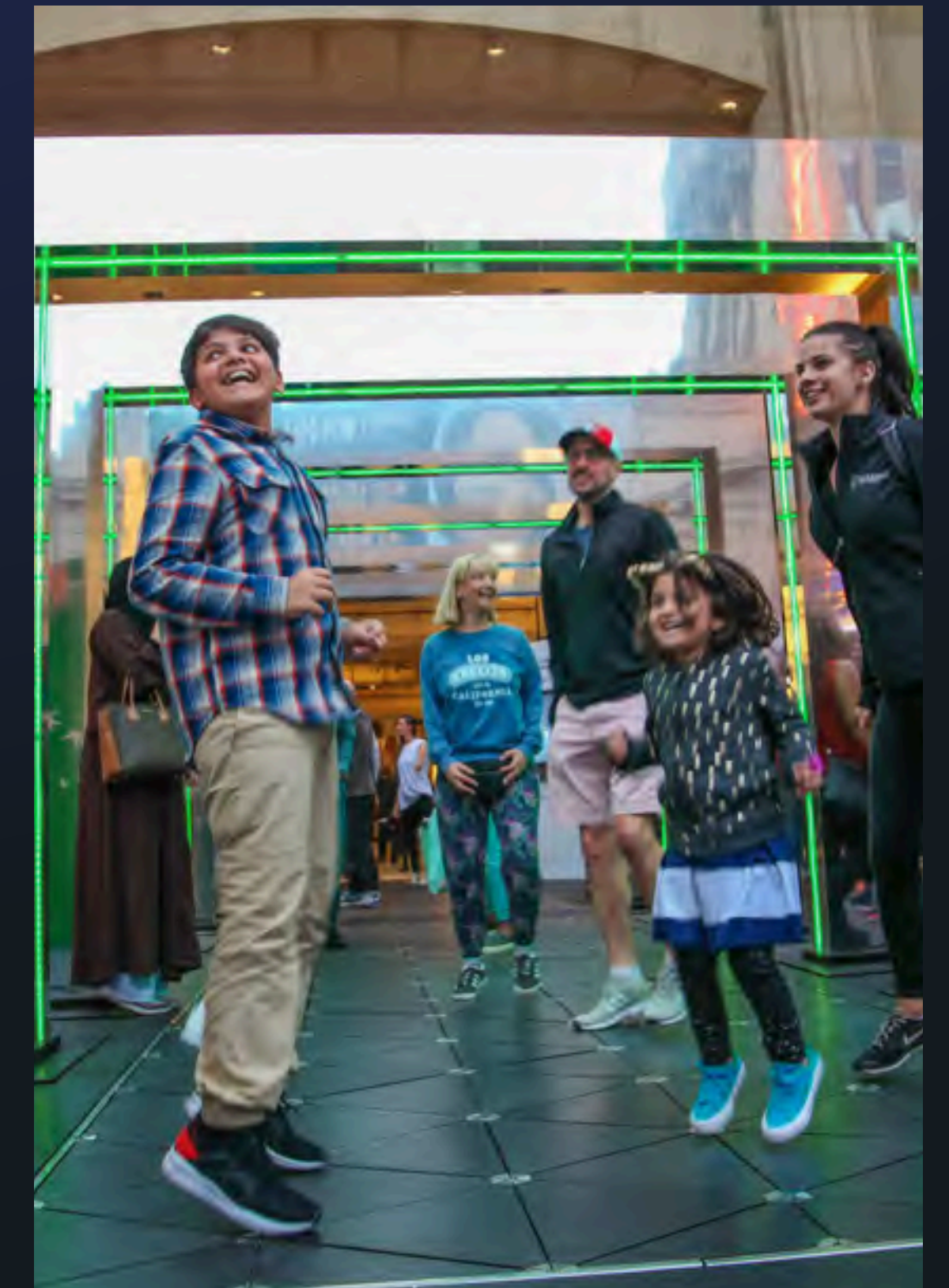

THANK YOU



TW CONSULTING
& TRADE LTD.

TW Consulting & Trade Ltd. (Malta)

Wolfgang Tweraser
CEO/President

Tel EU: +356 2701 9052 (office)
Tel EU: +356 9942 9829 (mobile)
Tel UAE: +971 50 209 3055

wolfgang@TWCTMT.com
www.TWCTMT.com