

CRUISE LINE CATALOGUE

ULTIMATE CABIN EXPERIENCE

PROFESSIONAL MINIBARS AND SAFES FOR CRUISE SHIPS

 **DOMETIC** **PROFESSIONAL**



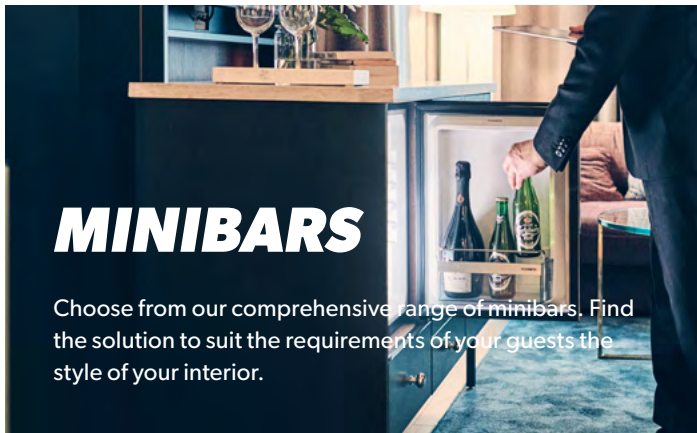

MINIBARS

Choose from our comprehensive range of minibars. Find the solution to suit the requirements of your guests the style of your interior.

MINIBARS

HiPro minibars	12 – 13
Drawer minibar	14 – 15
Ventilation guidelines	16 – 17

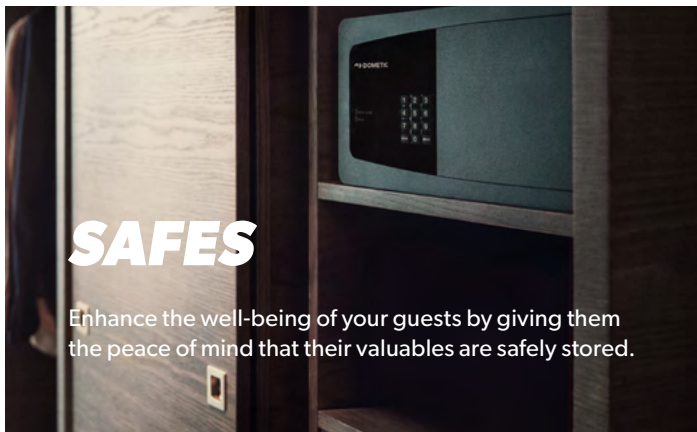

SAFES

Enhance the well-being of your guests by giving them the peace of mind that their valuables are safely stored.

SAFES

Dometic safes intro	18 – 21
Dometic Premium Class	22 – 25
Dometic Standard Class	26 – 29

DOMETIC ON THE WEB

Here's where you can find the complete Dometic range, with detailed information about all products. Plus, interesting facts about our company and download links for all our catalogues.

DOMETIC.COM/PROFESSIONAL

DOMETIC CRUISE LINE SOLUTIONS

Offer the ultimate cabin experience

Add comfort and convenience to your ship cabins. Dometic offer premium, space-efficient minibars and safes. The minibar ranges include silent, state-of-the art refrigeration technology, beneficial both for the environment and for your costs. For Dometic safes, featuring the latest security technology, choose between wall-hanging or in-drawer-installed safes - all tested to withstand any kind of a day at sea.

1. COST REDUCTION

Best-in-class energy efficiency – no matter which cooling technology is used.

2. SUSTAINABILITY

Sustainability is part our corporate culture and a major driving force in our research and development. All our minibars meet the most stringent regulatory criteria, this means environmental and health protection for production workers, customers and users.

ALWAYS AT YOUR SERVICE

We believe in sustainable innovation for a better guest experience.

3. GUEST EXPERIENCE

Strong cooling performance, robust build and noiseless operation allows guests to fully enjoy their travels.

4. STRONG PARTNERSHIP

After more than 50 years in the industry we have a strong promise to ensure care free maintenance.



DRIVING SUSTAINABILITY IN OUR INDUSTRY

After recently having been granted the “Most Efficient 2024” EnergyStar certification in the USA, Dometic also scored the “Leader Level” for its minibar products in the MindClick Sustainability Assessment Program (MSAP) of the hospitality sector. These accomplishments stand as a testament to the dedication and hard work of our exceptional team. We are committed to maintaining and even elevating our efforts in driving sustainability in our industry.

More and more hotel guests today expect a sustainable travel experience. Dedicated to a more sustainable lifestyle, they seek to reduce their overall carbon footprint – including that of their travels. When it comes to choosing their holiday accommodation, they are likely to prefer hotels that share their mindset. The MindClick Sustainability Assessment Program (MSAP) helps traveller and hotel brands to make well informed decisions in the jungle of labels and certifications.

The MindClick methodology rates candidates into three levels based on their scores: Starter, Achiever or Leader. Dometic achieved notably high scores in the rating, with emphasis on hotel impact, end-of-use considerations, packaging, and social/environmental aspects of production. That means that Dometic minibars are currently performing at “Leader Level”, which is not only an achievement we are proud of, but also a motivation to keep up our efforts in developing sustainable solutions for the future.



HIPRO CRUISE LINE MINIBARS

Efficient, silent, and maintenance-free

Dressed in all-black, the Dometic HiPro Cruise Line offers a timeless look that complements any cabin interior. Available in totally silent thermoelectric and highly efficient compressor versions, it's perfect for an undisturbed night's sleep and boasts an outstandingly low energy consumption. Thanks to a versatile layout, guests will benefit from access to neatly displayed snacks and beverages. Ensure passenger satisfaction with our efficient, silent, and maintenance-free in-cabin minibars. Specifically designed for the cruise industry, it is no wonder these small-but-mighty refrigerators, with their advanced cooling technology, are so popular with cruise line owners and guests alike.



Plastic door racks

Adjustable transparent door racks.



Control panel

Easy to use control panel with status LED.



Lock (optional)

Secure storage of minibar contents.

MODEL	ALPHA N30S	ALPHA N40S	ALPHA C40S
Cooling technology	Thermoelectric	Thermoelectric	Compressor
Model class (litre)	30	40	40
Storage volume (litre)	26	33	33
Door type	Metal sheet door	Metal sheet door	Metal sheet door
Product dimensions (H x W x D, mm)	520/384/415	550/405/435	550/405/481
Can be built-in/integrated	With ventilation	With ventilation	With ventilation
Sliding hinge kit	Yes	Yes	Yes
Variable door hinge	Yes	Yes	Yes
LED interior light	LED top light	LED top light	LED top light
Input rating (W)	55	55	45
Energy consumption (kWh/24 h)	0.259	0.262	0.130
Noise level (dB[A])	0	0	33
Energy class	F	F	C
Features	<ul style="list-style-type: none"> Noiseless Low energy consumption 1 x door rack 1 x plastic shelf Adjustable shelf 	<ul style="list-style-type: none"> Noiseless Low energy consumption 2 x door rack 1 x plastic shelf Adjustable shelf 	<ul style="list-style-type: none"> High performance Lowest energy consumption Integrated silent mode 2 x door rack 1 x plastic shelf Adjustable shelf
Options	Key lock	Key lock	Key lock



ALPHA N30S



ALPHA N40S



ALPHA C40S



Convenient slide-out access, noiseless operation, low energy consumption: Dometic DM 50 NTE provides 50 litres capacity featuring an automatic slide-out tray for snacks and mini bottles and an adjustable drawer for bottles and cans.

- Unique design for convenient slide-out access
- Thermoelectric cooling unit for low energy consumption
- Noiseless cooling comfort
- Patented and design awarded technology



DM 50 NTE F



TECHNICAL DATA

MODEL

DM 50 NTE D/F

Model class (litre)	50
Storage volume (litre)	45
Cabinet colors	Anthracite
Dimensions built-in version (H × W × D, in mm)	DM 50 NTE D: 418 × 550 × 524 DM 50 NTE F: 418 × 550 × 496
Can be built-in/integrated	with ventilation
LED interior light	●
Input rating (W)	75
Energy consumption (kWh/24 h)	0.33
Noise level (dB[A])	0
Features	<ul style="list-style-type: none"> • Highly flexible system of dividers and bottle fingers • DM 50 D: with a decorative anthracite panel and handle • DM 50 F: prepared for a decor panel to match the furniture design of the room
Options	<ul style="list-style-type: none"> • Lock



Pull-out cool

Removeable and smooth running sliding rails for convenient use.



Light the way

LED interior light – nicely features the snacks and beverages inside.



Organized storage

Simply slides out and self closing drawer provides easy access to the contents.

VENTILATION GUIDELINES

Important note

Please read these instructions carefully and follow all instructions, guidelines, and warnings included in all our product manuals in order to ensure that you install, use, and maintain our products properly at all times.

By using our products, you hereby confirm that you have read all instructions, guidelines, and warnings carefully and that you understand and agree to abide by the terms and conditions as set forth herein. You agree to use our products only for the intended purpose and application and in accordance with the instructions, guidelines, and warnings as set forth in the product manuals as well as in accordance with all applicable laws and regulations. A failure to read and follow the instructions and warnings set forth herein may result in an injury to yourself and others, damage to your product or damage to other property in the vicinity. Our product manuals, including the instructions, guidelines, and warnings, and related documentation, may be subject to changes and updates. For up-to-date product information, please visit dometic.com.

The heat which the cooling unit extracts from the refrigerator interior is emitted at the back of the fridge. If you have a free-standing model, sufficient ventilation is provided in most cases. If you want to integrate the fridge into a piece of furniture, however, the following instructions need to met.

Please note that there must be sufficient room for ventilation behind the refrigerator to prevent heat build-up. During installation, make

sure that the refrigerator is standing on a stable, level surface, and not directly near a heat source.

You can find all our documents, manuals and guidelines at documents.dometic.com.

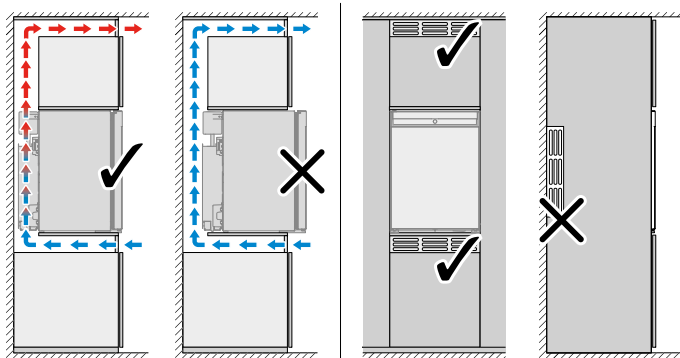
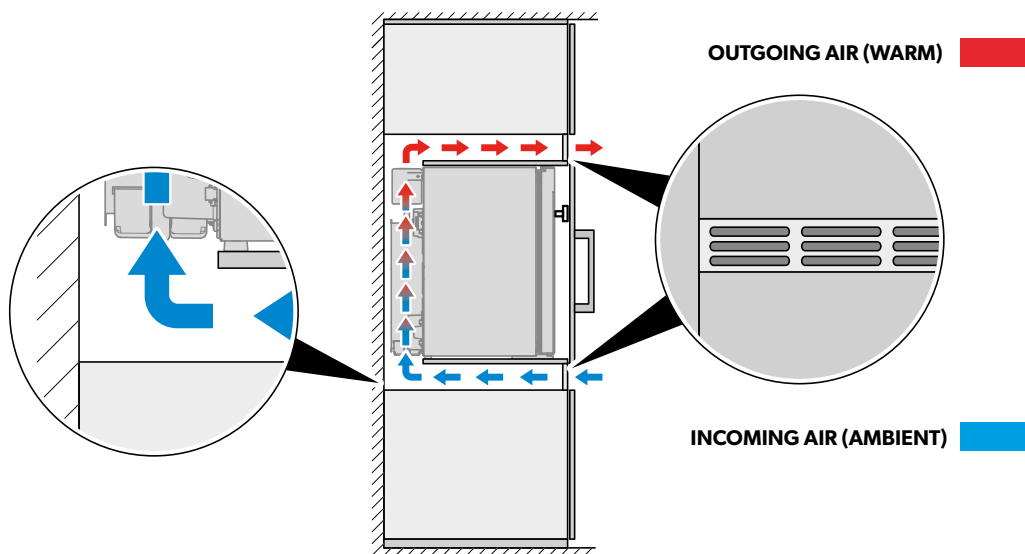

	Air inlet	Air outlet
N30, N40	≥ 200 cm ²	200 cm ²
A30, A40, C40	≥ 150 cm ²	200 cm ²

HIPRO MINIBARS

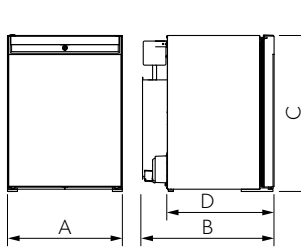
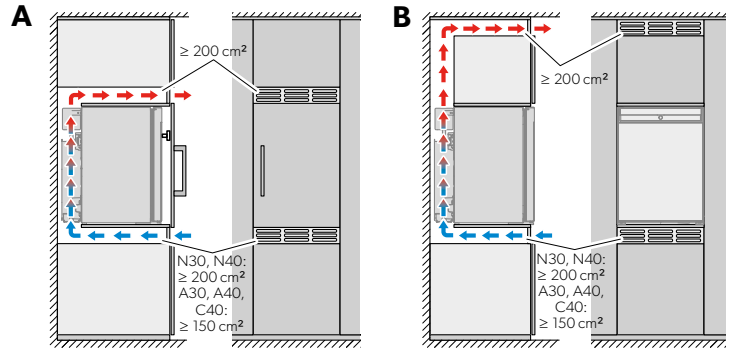
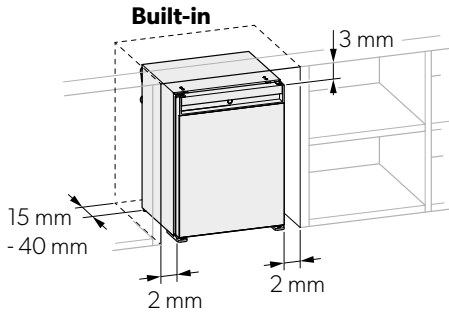

	A	B	C	D
A30	384 mm	446 mm	520 mm	356 mm
N30	384 mm	415 mm	520 mm	356 mm
A40	405 mm	466 mm	550 mm	376 mm
N40	405 mm	435 mm	550 mm	376 mm
C40	405 mm	481 mm	550 mm	376 mm

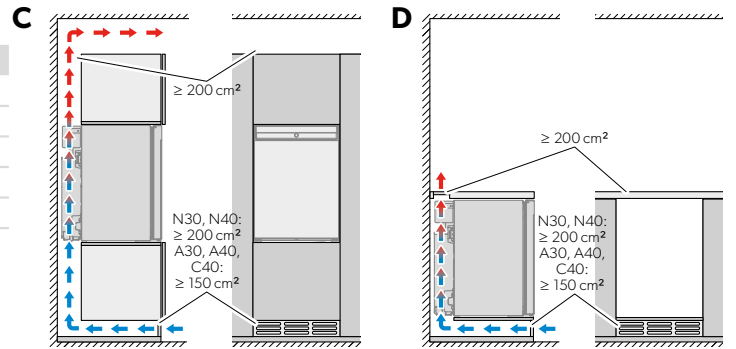

DM50 NTE DRAWER MINIBARS

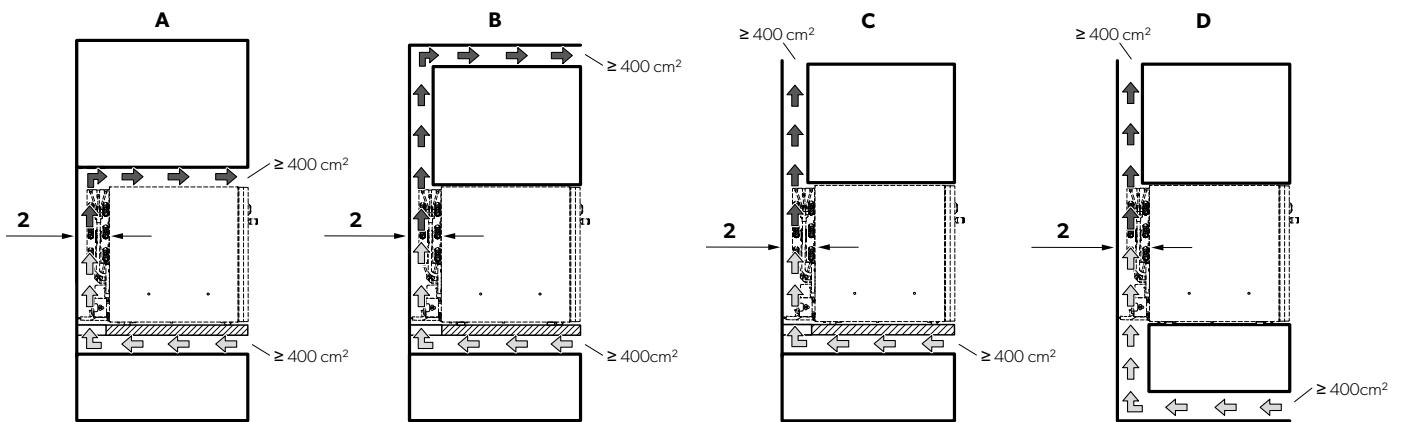

2* : Minimum 15 mm distance between the minibar's back (incl. the cooling unit) and the surrounding structure)





ES



FROM STANDARD TO PREMIUM

The range of Dometic proSafe models

Security is an essential requirement for hotel guests, and one of the main reasons for choosing or discarding a destination and a hotel. The Dometic Group aware of this, is always developing and improving all of its products in order to meet the needs of customers.

The latest product innovation Dometic has launched is a proSafe range which goes one step further in terms of design, functionality, technology and security. This proSafe range has a very modern design with a color display, an illuminated keypad, the latest anti-tampering system and a new website platform which offers the possibility to

operate the safe with the strictest security. The elegant cabinets of the new proSafe generation have rounded corners and edges for enhanced safety. Contemporary design.

- Master key
- LED interior light
- iAudit system – unique in the industry
- Remote Emergency Opening System (REOS 2.0)
– ultimate security and user comfort
- Battery level check



Premium Class

Excellence in form and function: Dometic innovations like iAudit tracking and the REOS Remote Emergency Opening System ensure security on all levels.

Standard Class

High security level combined with easy operation for perfect comfort and convenience.

PRODUCT FINDER – THE QUICK WAY TO FIND THE RIGHT PRODUCT

Laser-cut door

Our doors are precisely cut and crafted by a laser beam. This allows us to achieve 100% accuracy in dimensions and an extremely small clearance between the door and casing, making the door impossible to pry open.

Anti-Tamper system

With the anti-tampering system, Dometic offers a unique security feature for their models. All anti-tampering manipulation attempts are recorded in the electronic of the safe and can be tracked back at any time.

REOS code

REOS stands for Dometic’s Remote Emergency Opening System. The emergency-opening system from Dometic is based on an innovative encoding system. The unique solution combines advanced electronics with state-of-the-art online technology to allow simple yet highly secure emergency opening by authorised hotel staff.

Premium iAudit

All operations effected on a safe must be documented – for your own security and for your insurance provider. This is where

Dometic’s Premium iAudit system offers a truly convenient solution: the integrated microchip provides storage capacity for the last 1,000 events.

SAM

The unique Dometic safe management system (SAM) allows for iAudit Trail and one time emergency code generation (REOS) from a user friendly but PIN secured internet based software tool.

● Yes / – No / ○ Optional

WHAT’S IMPORTANT TO YOU?	PREMIUM CLASS	STANDARD CLASS
Easy operation	●	●
Motorised opening	●	●
LED interior light	●	●
LED display	●	●
Emergency opening with master key	●	●
Emergency opening with master code	●	●
Emergency opening with REOS Code	○	–
Anti-Tamper System	○	–
Premium iAudit	●	–
SAM	○	–
Laser-cut door	●	–
From page	34	38



SAFE TO SAY IT'S MORE CONVENIENT

PREMIUM CLASS IN-ROOM SAFES

DOMETIC PREMIUM CLASS SAFES

Protection for more privacy – comfortably and with absolute reliability. With a Dometic Premium Class proSafe, a hotel room becomes a perfectly private haven for the guest. A safe place for storage, conceived and implemented according to the newest standards. Its innovative and customisable design suits every hotel in a stylish way. Smooth surfaces and rounded edges make it easy to look after and give it long-lasting character. A color display and the integrated soft-touch keypad make operation easy. And a Premium Class proSafe

also breaks new ground when it comes to protective properties: pioneering technology like the unique iAudit and the anti-tampering system ensure security on all levels. The demand for contemporary security systems with added convenience is supported by special features such as REOS 2.0 software with its emergency code-opening system (optional).

- LED interior light
- Laser-cut door and frame
- iAudit for convenient documentation
- Emergency opening with key and master code
- Remote Emergency Opening System (REOS 2.0) – ultimate security and user comfort (optional)



WIDE CHOICE OF MODELS AND SIZES

Dometic ProSafe MD series Premium Class safes are available in various sizes to suit different capacity demands, interior designs and installation conditions. Sizes range from 8.2 to 29 litres.



Batteries included

Dometic safes come ready to use.



Plug

Optional inside plug to charge mobile devices.



Automatic opening

Safe door opens automatically.



Fixing kit

Optional fixing kit for secure fastening.

MODEL	MD 283	MD 363	MD 383
TECHNICAL DATA			
Type of product	Electronic safe		
Capacity (litres)	8.2	24	28
Exterior dimensions (H×W×D, mm)	165 × 280 × 235	190 × 360 × 410	190 × 380 × 450
Interior dimensions (H×W×D, mm)	162 × 277 × 185	187 × 357 × 360	187 × 377 × 400
Steel thickness (mm)	Door: 5.0 / Body 1.2	Door: 5.0 / Body 1.5	Door: 5.0 / Body 1.5
Net weight (kg)	6.1	10.2	11.3
Keypad	ADA-compliant rubber keypad		
Display	White LED color display, 4-digit guest code, English language		
Locking mechanism	Two 18 mm solid steel bolts		
Locking system	Motorised with automatic opening		
Power	4 LR6/AA 1.5 V batteries (incl.)		
Cabinet color	Anthracite		
FEATURES			
LED interior light	●	●	●
Laser cut technology	●	●	●
Masterkey opening	●	●	●
Mastercode opening	●	●	●
Anti-tampering System	○	○	○
REOS	○	○	○
iAudit	●	●	●
Laptop size	–	15"	17"
OPTIONS			
	<ul style="list-style-type: none"> • Left-hand hinge • Fixing Kit 	<ul style="list-style-type: none"> • Left-hand hinge • Two steps emergency code opening (REOS) • Fixing Kit 	<ul style="list-style-type: none"> • Left-hand hinge • Two steps emergency code opening (REOS) • Fixing Kit



MODEL	MD 408	MD 493	MDD 403
TECHNICAL DATA			
MODEL	MD 408	MD 493	MDD 403
Type of product	Electronic safe		
Capacity (litres)	22.5	29	15.7
Exterior dimensions (H × W × D, mm)	190 × 405 × 350	190 × 490 × 370	200 × 400 × 400
Interior dimensions (H × W × D, mm)	187 × 402 × 300	187 × 487 × 320	135 × 315 × 370
Steel thickness (mm)	Door: 5.0 / Body 1.5	Door: 5.0 / Body 1.5	Door: 5.0 / Body 1.5
Net weight (kg)	10.4	12.4	17.5
Keypad	ADA-compliant rubber keypad		
Display	White LED color display, 4-digit guest code, English language		
Locking mechanism	Two 18 mm solid steel bolts		
Locking system	Motorised with automatic opening		
Power	4 LR6/AA 1.5 V batteries (incl.)		
Cabinet color	Anthracite		
FEATURES			
LED interior light	●	●	●
Laser cut technology	●	●	●
Masterkey opening	●	●	●
Mastercode opening	●	●	●
ANTI-TAMPERING SYSTEM	○	○	○
REOS	○	○	○
iAudit	●	●	●
Laptop size	15"	17"	15"
OPTIONS			
	<ul style="list-style-type: none"> • Left-hand hinge • Two steps emergency code opening (REOS) • Fixing Kit 	<ul style="list-style-type: none"> • Left-hand hinge • Fixing Kit 	<ul style="list-style-type: none"> • Two steps emergency code opening (REOS) • Fixing Kit

● Yes / – No / ○ Optional

DOMETIC STANDARD CLASS SAFES

Robustly made with user-friendly features and functions

It puts hotel guests' mind at rest to have a safe place for their valuables while travelling. Providing a secure space for important or valuable objects yet it is a distinctive feature when choosing a hotel room or suite. With a Standard Class proSafe, you can create a reliable spot in a guest room that is worth every penny. Security and functionality are paramount with all Dometic safe models. The Standard Class safe models offer your guests a high level of security thanks to their robust construction. Their simple and intuitive usability provides perfect comfort and convenience.

- Robust and reliable
- LED display
- LED interior light
- Master key and master code emergency opening
- Wide choice: vertical, horizontal, top-opening

DOMETIC PROSAFE MDL – VERTICAL OR HORIZONTAL

MDL 408



MDL 193

With quality and security at their core, these value-for-money in-room safes significantly enhance the security of existing hotel rooms.

- Value-for-money solution for upgrading hotel rooms
- Vertical or horizontal model – both with 18.4 litres capacity
- Easy installation inside a cabinet or on the wall
- Emergency opening with master code or master key
- Battery-low warning alerts users to change battery

DOMETIC PROSAFE MD 310 / 390 / 450 SAFE INVESTMENT

The doors on all the Standard Class safe models are precisely cut and crafted. Their robust construction and a locking system with extra-strong steel bolts leave no point of attack for burglars. The LED interior light minimises the risk of forgotten valuables. Fast and secure emergency opening is possible with a master key or master code (depending on the model).

- Robust, reliable construction for optimal safety
- LED interior light makes the contents visible at a glance
- Emergency opening with master key or master code



DOMETIC PROSAFE MDT TOP-OPENING SAFE

Part of the Dometic Standard Class range, the Dometic proSafe MDT 400 X top-opening safe provides a simple, yet ingenious solution that is easy to operate and safe to use. The top-opening drawer safe can be integrated in an existing furniture drawer and provides easy access to guests' valuables. At the same time it meets the highest demands on ergonomic design, comfort and security with an LED inside light for standard, master key and master code opening possibility in case of emergency, digital LED illuminated keypad, four-digit code and top-opening stabilizer arm. An audio signal confirms that the safe is securely locked.

- Convenient access from above
- LED interior light makes the contents visible at a glance
- Enough room to fit laptop and tablet computers
- Ideal for installation into existing hotel room drawer
- Stabilizer arm for smooth opening and closing of the lid



Easy operation

The operation is easy to understand and explained via the pictogram.

Handle

Integrated handle for easy opening and closing.

Light the way

Standard LED interior lighting.

Soft close

Muted door closing.

SAFETY & SECURITY

SAFETY SOLUTIONS / PROSAFE STANDARD CLASS



MODEL	MD 310	MD 390	MD 450
TECHNICAL DATA			
Type of product	Electronic safe		
Capacity (litres)	9	31.5	30.4
Exterior dimensions (H × W × D, mm)	165 × 310 × 245	200 × 390 × 480	200 × 450 × 400
Interior dimensions (H × W × D, mm)	161 × 306 × 182	196 × 386 × 418	196 × 446 × 348
Steel thickness (mm)	Door: 5.0 / Body 2	Door: 5.0 / Body 2	Door: 5.0 / Body 2
Net weight (kg)	7.1	14.3	14.5
Keypad	Rubber keypad		
Display	Red LED 4-digit guest code, English language		
Locking mechanism	Two 19 mm steel bolts		
Locking system	Motorised with automatic opening		
Power	4 LR6/AA 1.5 V batteries (incl.)		
Cabinet color	Anthracite		
FEATURES			
Confirmation buzzer	●	●	●
LED interior light	●	●	●
Door handle opening	-	-	-
Masterkey opening	●	●	●
Mastercode opening	●	●	●
Anti-tampering System	-	-	-
REOS	-	-	-
iAudit	-	-	-
Laptop size	-	17"	15"
OPTIONS			
(available for all models)	<ul style="list-style-type: none"> • Left-hand hinge • Fixing kit 		

**MDT 400X****MDL 408****MDL 193**

	Electronic safe	
9.7	18.4	18.4
130 x 400 x 350	190 x 405 x 300	405 x 190 x 300
75 x 380 x 300	187 x 402 x 245	402 x 187 x 245
Door: 3.0 / Body 1.5	Door: 4.0 / Body 1.5	
9	10	
Rubber keypad	Rubber keypad	
Red LED 4-digit guest code, English language	Red LED 4-digit guest code, English language	
Two 19 mm steel bolts	Two 18 mm solid steel bolts	
Motorised with automatic opening	Motorised	
4 LR6/AA 1.5 V batteries (incl.)	4 LR6/AA 1.5 V batteries (incl.)	
Anthracite	Anthracite	
●	-	-
●	-	-
-	●	●
●	●	●
●	●	●
-	-	-
-	○	○
-	○	○
15"	13"	13"
<ul style="list-style-type: none"> Fixing kit 	<ul style="list-style-type: none"> Left-hand hinge Fixing kit White cabinet color 	<ul style="list-style-type: none"> Left-hand hinge Fixing kit White cabinet color

● Yes / - No / ○ Optional

**BELGIUM, NETHERLANDS
& LUXEMBOURG**

Dometic BeNeLuX

Lourdesstraat 84 B
B-8940 Geluwe

Tel +32 2 3598040
+32 (0) 478 6414 68

Mail hospitality_nl@dometric.com

DENMARK

Dometic Denmark A/S

Nordensvej 15, Taulov
DK-7000 Fredericia

Tel +45 75585966

Mail hospitality_ne@dometric.com

FINLAND

Dometic Finland Oy

Valimotie 15

FIN-00380 Helsinki

Tel +358 20 7413220

Mail hospitality_ne@dometric.com

FRANCE

Dometic SAS

6 Avenue du Poteau
Batiment B1

60300 Chamant

Tel +33 3 44633521/33

Mail hospitality_fr@dometric.com

**GERMANY, AUSTRIA
& SWITZERLAND**

Dometic GmbH

In der Steinwiese 16
D-57074 Siegen

Tel +49 (0) 271 692 134 / 142
+49 (0) 271 692 127

Mail hospitality_de@dometric.com

ITALY

Dometic Italy S.r.l.

Via Virgilio, 3

I-47122 Forlì (FC)

Tel +39 0543 754901

Mail hospitality_it@dometric.com

MIDDLE EAST & AFRICA

Dometic Middle East FZCO

P.O. Box 17860

S-D 6, Jebel Ali Freezone

Dubai

Tel +971 4 883 3858

Mail hospitality_ae@dometric.com

NORWAY

Dometic Norway AS

Elveveien 30B

3262 Larvik

Tel +47 33428450

Mail hospitality_ne@dometric.com

SWEDEN

Dometic Scandinavia AB

Gustaf Melins gata 7

S-421 31 Västra Frölunda

Tel +46 31 7341100

Mail hospitality_ne@dometric.com

SPAIN

Dometic Spain, S.L.

Avda. Sierra del Guadarrama, 16

E-28691 Villanueva de la Cañada

Madrid

Tel +34 91 833 6089

Mail hospitality_es@dometric.com

PORTUGAL

Dometic Spain, S.L.

Branch Office em Portugal

Rot. de São Gonçalo nº 1– Esc. 12

2775-399 Carcavelos

Tel +351 219 244 173

Mail hospitality_pt@dometric.com

UNITED KINGDOM & IRELAND

Dometic UK Ltd.

Dometic House, The Brewery,

Blandford St. Mary's

Dorset DT11 9LS

Tel +44 125 841 4581

Mail hospitality_uk@dometric.com

**FOR SALES IN POLAND, EASTERN
EUROPE, TURKEY & ISRAEL, PLEASE
CONTACT**

HOSPITALITY_EE@DOMETIC.COM

**FOR SALES IN GREECE, PLEASE
CONTACT**

HOSPITALITY_GR@DOMETIC.COM

We distribute our products in around 100 markets. Please mail us at: hospitality@dometric.com, or check our website Dometric.com/hospitality

USA & CANADA

Dometic Corporation

Columbia Centre 1

5600 N. River Rd

Suite 250

Rosemont, IL 60018

Tel +1 574 326 7635

Tel +1 574 294 2511

Mail hospitality_us@dometric.com

MEXICO

Dometic MX

Circuito Médicos No. 6 Local 1

Colonia Ciudad Satélite

CP 53100 Naucalpan de Juárez

Estado de México

Tel +52 55 5374 4108

Mail hospitality_mx@dometric.com

EXPORT

Dometic Competence Center

Circuito Médicos No. 6 Local 1

Colonia Ciudad Satélite

CP 53100 Naucalpan de Juárez

Estado de México

Tel +52 55 5374 4108

Mail hospitality_mx@dometric.com

AUSTRALIA

Dometic Austria

7 Nursery ave

Clayton South

Victoria 3169

Tel +61 1800 212 121

Mail hospitality_au@dometric.com

CHINA

Dometic Asia Co., Ltd

Room 803-805A, Waterfront Place Block E,

No.31, Lane 168, Daduhe Road, Putuo

District, Shanghai, China

Tel +86-21-60325088

Mail hospitality_cn@dometric.com

JAPAN

Dometic KK

Maekawa-Shibaura, Bldg. 2

2-13-9 Shibaura Minato-ku

Tokyo 108-0023

Tel +81 3 5445 3333

Mail hospitality_jp@dometric.com