

Alpha VERSADRIVE®



CUT
DRILL
TAP

LESS
DOING...

**MORE
DONE!**



VERSADRIVE



Heavy Duty Impact Wrench Adaptors	6
Rapid-Lock 1/2" Impact Wrench Adaptors	6
Rapid-Lock Mag-Based Drill Adaptors	7
Mag-Based Drill Adaptors	7
Rapid-Lock 1/4" Impact Driver Adaptors	8
Rapid-Lock SDS Plus Adaptors	8
Rapid-Lock Morse Taper Arbors	9
Morse Taper Arbors	9
Rapid-Lock Extension Arbors - 300mm	10
Rapid-Lock Extension Arbors - 130mm	10
Clutched Tap Adaptors	11
Blind Hole Tapping Kit	11
Clutched Blind Hole Tap Collets	11
Weldon Shank Tap Collet Holders	11
Impact Starter Kit	12
Impact Installation Kit	13
TurboTip® Drill Bits	14
Cobalt Drill Bits	16
ImpactaStep Cutters	18
Impact Step Drills	20
Impact Reamer s	22
ImpactaTaps®	24
Spiral Flute Taps	29
Combi Drill Taps	30
HD ImpactaTaps® Drill Taps	32
Combination DrillSinks	34
3 Flute Countersinks 90°	36
TCT Hole Cutters	38
Extra Long TCT Hole Cutters	40
CarbideMax® TCT Broach Cutters	42
Extra Long CarbideMax® TCT Broach Cutters	44
MutliSink® Combination Countersink Tools	46
Reference Guide	48

IMPACT RATED

DRILLING



REAMING



TAPPING



SUITS



1/2" IMPACT
WRENCH



3/4" IMPACT
WRENCH



1/4" IMPACT
DRIVER



HAMMER
DRILL



ADAPTOR



TOOL



ROTARY RATED

BROACHING / 
COUNTERSINKING / 
HEAVY TAPPING / 

SUITS

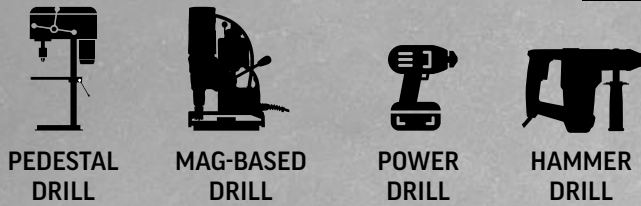

ADAPTOR



TOOL



IMPACT RATED

Heavy Duty Impact Wrench Adaptor



- Engineered for heavy duty applications
- Impact hardened manganese phosphate adaptor
- 1/2" HD adaptor has full-forward release
- that reduces the risk of tool loosening during use

Code: 111120-012A

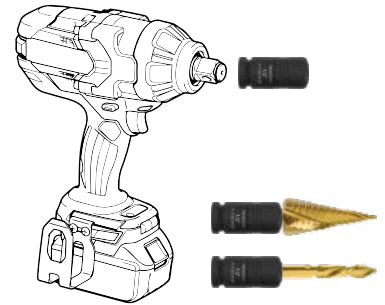

- Engineered for heavy duty applications
- 3/4" adaptor has pull back release
- Developed to work with latest generation of high torque power impact wrenches capable of generating above 1,000Nm of torque

Code: 111120-034A

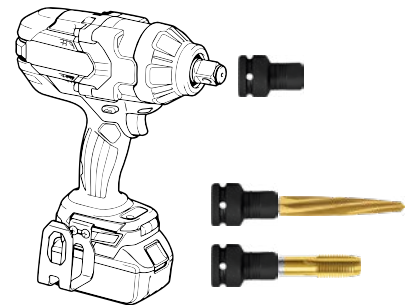

IMPACT RATED

Rapid-Lock 1/2" Impact Wrench Adaptor

Rated to 650nm

Supplied with retention pin & ring

- Rapid-Lock single handed loading
- Improved quick release collar prevents accidental tool release caused by vibrations or contact with the work-piece
- Knurled collar provides ultimate grip in greasy or damp conditions
- High quality, heavy duty steel components
- Increased strength for withstanding the drive forces from the latest generation of high torque 1/2" impact wrenches
- Converts standard 1/2" impact wrenches for use with VersaDrive



Code: 111130-012A

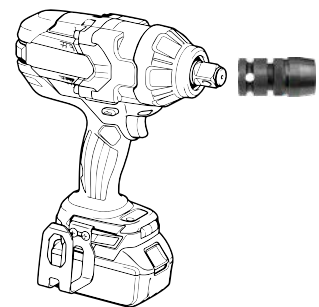

Click or Scan & See | ▶



Click or Scan | Pack Sizes

ROTARY RATED

Rapid-Lock Mag-Based Drill Adaptor



- Rapid-Lock single handed loading
- Improved quick release collar prevents accidental tool release caused by vibrations or contact with the work-piece
- Fits all standard 19.05 mm ($3/4$ ") mag-based drill arbors

Code: 111035-01

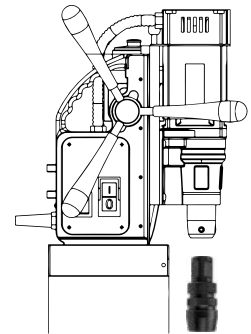

VERSADRIVE

IMPACT RATED

ROTARY RATED

Mag-Based Drill Adaptor



- 3 x stainless steel M8 doghead grub screws supplied per adaptor
- Fits into any standard 19.05mm ($3/4$ ") mag-based drill arbor

Code: 111030-0001

WSL

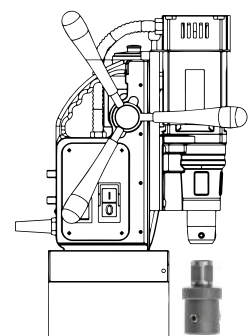

IMPACT RATED

Rapid-Lock 1/4" Impact Driver Adaptor

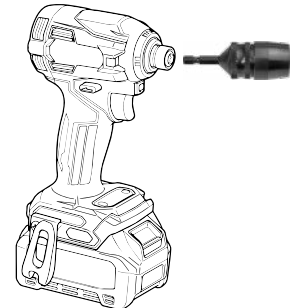
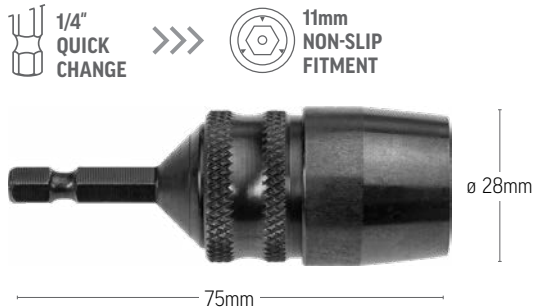

- Rapid-Lock single handed loading
- Improved quick release collar prevents accidental tool release caused by vibrations or contact with the work-piece
- Knurled collar provides ultimate grip in greasy or damp conditions

- High quality, heavy duty steel components
- Increased strength for withstanding the drive forces from the latest generation of high torque 1/4" hex impact drivers
- Converts standard 1/4" impact drivers for use with VersaDrive

RECOMMENDED FOR UP TO 10.0mm DIAMETER



Code: 111026-014A

IMPACT RATED

ROTARY RATED

Rapid-Lock SDS Plus Adaptor

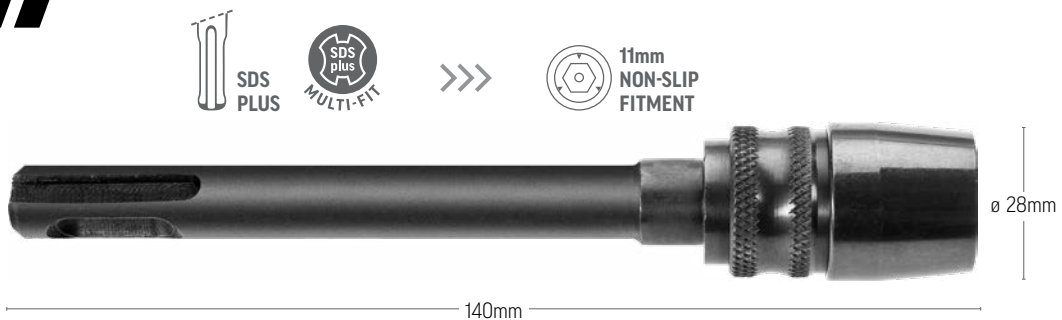

- Rapid-Lock single handed loading
- Improved quick release collar prevents accidental tool release caused by vibrations or contact with the work-piece
- Knurled collar provides ultimate grip in greasy or damp conditions
- High quality, heavy duty steel components
- Converts all standard SDS Plus rotary hammer drills for use with VersaDrive system (in rotary mode)

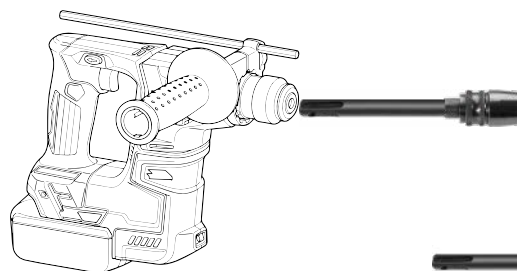

USE IN ROTARY MODE ONLY



Code: 112010-01



Click or Scan & See | ▶



Click or Scan | Pack Sizes

ROTARY RATED

Rapid-Lock Morse Taper Arbor



METRIC		HANDI PACK	
Shank Size	ø mm	OAL mm	CODE 1 PCE
MT2	28	130	111045-02
MT3	28	147	111045-03

- Ideal for workshop use with radial arm drills and pillar drills
- Rapid-Lock single handed loading action
- Quick release collar that prevents accidental tool release caused by vibrations or contact with the workpiece
- Knurled collar - ultimate grip in greasy or damp conditions
- High quality, heavy duty steel components

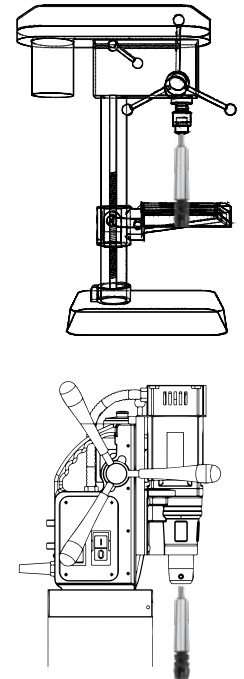

VERSADRIVE

ROTARY RATED

Morse Taper Arbor



METRIC		HANDI PACK	
Shank Size	ø mm	OAL mm	CODE 1 PCE
MT2	30	80	111040-001
MT3	30	99	111040-002

- 3 x stainless steel M8 grub screws supplied per adaptor
- Ideal for workshop use with radial arm drills and pedestal drill
- Also suitable for mag-based drills with morse taper capability

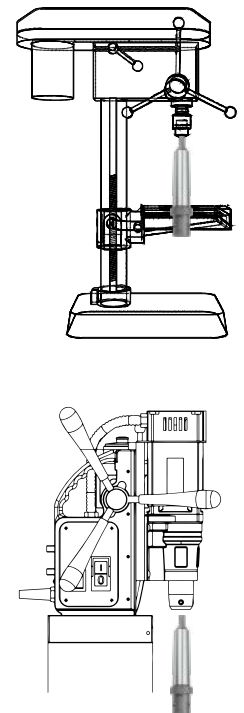

Indicates product is available on enquiry (lead times may vary)

IMPACT RATED

ROTARY RATED

Rapid-Lock Extension Arbor – 300mm

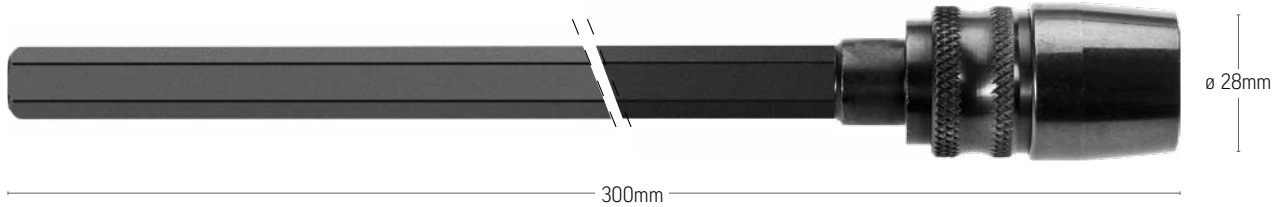

- Extends the working reach of all VersaDrive tools
- Rapid-Lock single handed loading action and can also be used in combination with other VersaDrive adaptors
- Hex shank for non-slip use in any drill chuck
- Improved quick release collar that prevents accidental tool release caused by vibrations or contact with the workpiece
- Knurled collar - ultimate grip in greasy or damp conditions
- High quality, heavy duty steel components
- Rated for impact wrench use

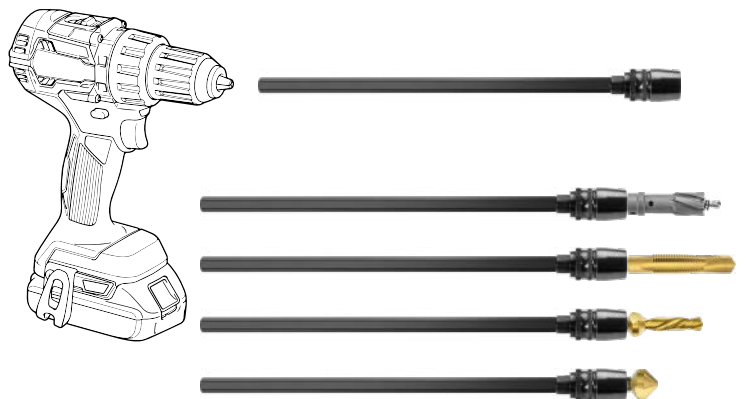

Code: 111015-300

IMPACT RATED

ROTARY RATED

Rapid-Lock Extension Arbor – 130mm

- Extends the working reach of all VersaDrive tools
- Rapid-Lock single handed loading action and can also be used in combination with other VersaDrive adaptors
- Hex shank for non-slip use in any drill chuck
- Improved quick release collar that prevents accidental tool release caused by vibrations or contact with the workpiece
- Knurled collar - ultimate grip in greasy or damp conditions
- High quality, heavy duty steel components
- Rated for impact wrench use

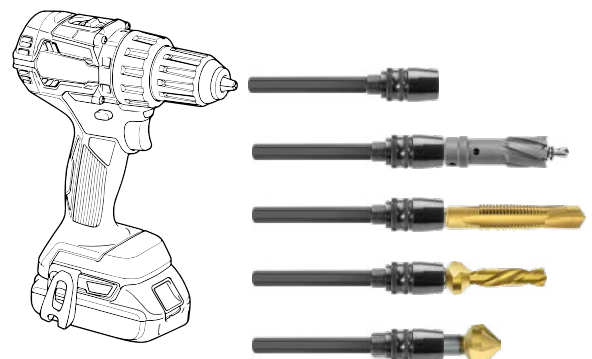
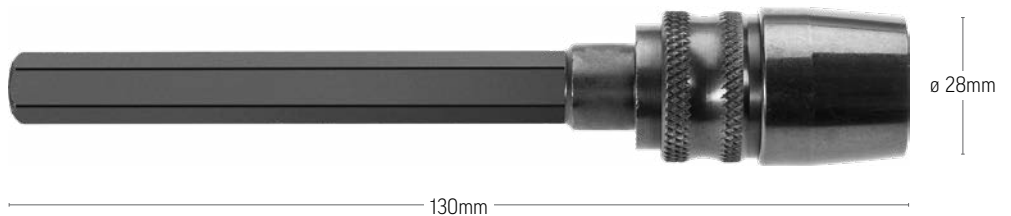

Code: 111015-130



Click or Scan & See | ▶



Click or Scan | Pack Sizes

IMPACT RATED

ROTARY RATED

Clutched Tap Adaptor

Versatile blind hole tapping



The VersaDrive clutched tap collet system is a unique method of effectively threading blind holes.

All collets work with the full range of VersaDrive taps. When the tap reaches the bottom of the hole, the clutch system will engage and stop the tap from breaking. The tap is then reversed out of the completed hole.

This system fits a 19.05mm ($\frac{3}{4}$ ") mag-based drill arbor, or can be adapted for use with a $\frac{1}{2}$ " or $\frac{3}{4}$ " impact wrench.

- Quick change system accepts all VersaDrive taps
- Collets are pre-set to the appropriate clutch settings
- Further clutch adjustment options available
- For blind hole tapping with VersaDrive spiral flute taps
- For use with variable speed, reversible mag-based drills, pedestal drills or impact wrenches

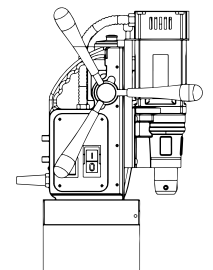
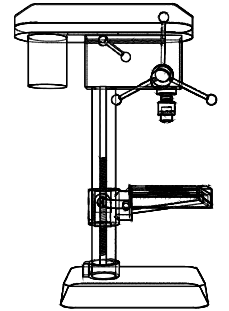
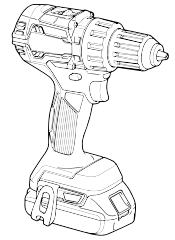

VERSADRIVE



Weldon Shank Tap Collet Holder

19.05mm | $\frac{3}{4}$ " **Code: 120010**



Clutched Blind Hole Tap Collet

M6-M12 **Code: 121015-M12**

M16-M24 **Code: 121015-M24**



M6-M24

Blind Hole Tapping Kits

7 x Spiral Flute Taps (Metric Coarse):

M6, M8, M10, M12, M16, M20 & M24

includes $\frac{1}{2}$ " Impact Adaptor **Code: 121015-SET12**

includes $\frac{3}{4}$ " Impact Adaptor **Code: 121015-SET34**

IMPACT RATED

ROTARY RATED

The Impact Kits have been created to meet the demanding Australian on-site industrial and remote location hole-making challenges i.e heavy engineering, mining, plant maintenance, construction, rail, heavy industrial and steel fabrication.

Utilises all portable tool types with a complete range of adaptors – the perfect starter kits.

Presented in a tough ABS case with cut-out foam inserts, protecting your tools from the elements in the harshest environments.



Impact Starter Kit

Metric Set

19 PCE

Set Contents:

- 3 x Reamers 14.0, 18.0 & 22.0mm
- 3 x DrillTaps M6, M8 & M10
- 3 x ImpactaTaps M12, M16 & M20
- 7 x TurboTips 6.8, 8, 8.5, 10.0, 10.5, 12.0 & 14.0mm
- 1 x 1/4" Impact Driver Adaptor
- 1 x 1/2" Impact Wrench Adaptor
- 1 x 130mm Extension

Code: STC-TOP-VSD01

Imperial Set

19 PCE

Set Contents:

- 3 x Reamers 9/16, 11/16 & 13/16"
- 3 x DrillTaps 1/4, 5/16 & 3/8" UNC
- 3 x ImpactaTaps 1/2, 5/8 & 3/4" UNC
- 7 x TurboTips #F, 9/32, 5/16, 3/8, 27/64, 7/16 & 1/2"
- 1 x 1/4" Impact Driver Adaptor
- 1 x 1/2" Impact Wrench Adaptor
- 1 x 130mm Extension

Code: STC-TOP-VSD02



Click or Scan & See | ▶



Click or Scan | Pack Sizes



Impact Installation Kit

Metric Set

28 PCE

Set Contents:

- 6 x TurboTips 6, 6.35, 8.0, 10.5, 12 & 14mm
- 5 x Hole Cutters 14, 17, 18, 20 & 22mm
- 2 x ImpactaStep Cutters 16 & 22mm
- 3 x DrillTaps M6, M8 & M10
- 3 x ImpactaTaps M12, M16 & M20
- 4 x Reamers 12, 14, 18 & 22mm
- 1 x 1/4" Impact Driver Adaptor
- 1 x 1/2" Impact Wrench Adaptor
- 1 x Magnet Drill Adaptor
- 1 x 130mm Extension
- 1 x 300mm Extension

Code: STC-EMID-MEIK

(replaces VSD-INSET-ME)

Imperial Set

28 PCE

Set Contents:

- 6 x TurboTips 1/4, 9/32, 5/16, 3/8, 7/16 & 1/2"
- 5 x Hole Cutters 9/16, 5/8, 3/4, 7/8 & 1"
- 2 x ImpactaStep Cutters 9/16 & 13/16"
- 3 x DrillTaps 5/16, 3/8 & 1/2"
- 3 x ImpactaTaps 1/2, 5/8 & 3/4"
- 4 x Reamers 1/2, 9/16, 11/16 & 13/16"
- 1 x 1/4" Impact Driver Adaptor
- 1 x 1/2" Impact Wrench Adaptor
- 1 x Magnet Drill Adaptor
- 1 x 130mm Extension
- 1 x 300mm Extension

Code: STC-EMID-INIK 



IMPACT RATED

ROTARY RATED

TurboTip® Drill Bits

IDEAL FOR



CAST IRON



STAINLESS STEEL



STEEL



ALUMINIUM



BRASS



PLASTIC

FAST PERFORMANCE



IMPACT WRENCH | IMPACT DRIVER

LONG LIFE



POWER DRILL | MAG BASED DRILL



11mm NON-SLIP SHANK

50mm



∅ diameter

87mm



MAX. MATERIAL THICKNESS

VersaDrive TurboTip® Drill Bits are stepped tip bits that drill at twice the speed of standard bits without the need for pilot drilling while cutting a perfectly round hole.

Turbo-charge your drilling performance by using this revolutionary tool with an impact wrench or impact driver. Double-hardened and titanium coated for faster drilling and reduced wear.

VersaDrive TurboTip® Drill Bits have a patented non-slip, hex shank suitable for use in any standard 1/2" drill chuck for cordless or corded drills or used with a VersaDrive Rapid-Lock adaptor for use in a wide range of power tools such as magnetic drills.

- Specially hardened for impact wrench use
- 50% faster drilling with 30% less pressure
- Fully impact rated on structural steel
- Incredible finished hole quality
- Instant drill start with no slipping
- No 'snatch' when drill bit breaks through
- Fantastic tool life
- Titanium nitride coating reduces heat and increases lubricity for extended life
- High strength, non-slip shank design



HANDI PACK
Supplied in hangable plastic pack



Recommended Adaptors



Speeds & Feeds | PG 51



Click or Scan & See |



Alpha Liquid Gold Cutting Fluid*



Click or Scan | Pack Sizes

*Alpha Liquid Gold Cutting Fluid is formulated for extreme cutting performance and is recommended for use when tapping, drilling or reaming into all metals

IMPACT RATED

ROTARY RATED

Cobalt Drill Bits

IDEAL FOR

- HARD STEEL** ●●●●●
- CAST IRON** ●●●●●
- STAINLESS STEEL** ●●●●●
- STEEL** ●●●●●
- ALUMINIUM** ●●●○●
- BRASS** ●●●○●
- PLASTIC** ●●●●●

FAST PERFORMANCE

- IMPACT WRENCH**
 - IMPACT DRIVER**
- UP TO 10mm**

LONG LIFE

- POWER DRILL**
- PEDESTAL DRILL**



HANDI PACK
Supplied in hangable plastic pack

11mm
NON-SLIP
SHANK



40mm
MAX.
MATERIAL
THICKNESS

VersaDrive Cobalt Drill Bits are a premium grade 8% cobalt drill with fully ground flutes, 135° split point and Titanium coating for faster drilling and reduced wear.

Suitable for heavy fabrication use, this Cobalt Drill Bit can also be used to drill stainless steel, mild steel, cast iron and a wide range of other structural materials.

VersaDrive drill bits have a patented non-slip, hex shank suitable for use in any standard 1/2" drill chuck for cordless or corded drills or used with a VersaDrive Rapid-Lock adaptor for use in a wide range of power tools such as magnetic drills.

- Specially hardened for impact wrench use
- Fast drilling with minimal kick-back
- Dual hardened for impact wrench use up to 10mm (see application information)
- Precision ground flutes for easy chip clearance
- 135° split point for easy starting and high accuracy
- 8% cobalt for long life and high performance
- Titanium nitride coating reduces heat and increases lubricity for extended life
- High strength, non-slip shank design



Recommended Adaptors



Speeds & Feeds | PG 52



Click or Scan & See | ▶



Alpha
Liquid Gold
Cutting Fluid*



Click or Scan | Pack Sizes









*Alpha Liquid Gold Cutting Fluid is formulated for extreme cutting performance and is recommended for use when tapping, drilling or reaming into all metals

IMPACT RATED

ROTARY RATED

ImpactaStep Cutters

IDEAL FOR

-  HIGH TENSILE STEEL ●●●●○
-  CAST IRON ●●●●○
-  STAINLESS STEEL ●●●●○
-  STEEL ●●●●●
-  ALUMINIUM ●●●●○
-  BRASS ●●●●○
-  FIBREGLASS ●●●●○
-  PLASTIC ●●●●●

FAST PERFORMANCE

-  IMPACT WRENCH
-  IMPACT DRIVER

LONG LIFE

-  POWER DRILL
-  PEDESTAL DRILL



HANDI PACK
Supplied in hangable plastic pack

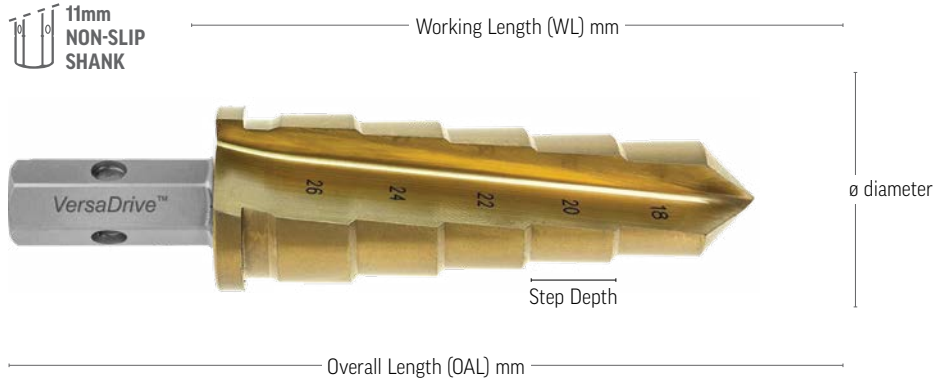

Alpha VersaDrive is designed to meet the demanding Australian on-site industrial requirements, and remote location hole-making challenges i.e heavy engineering, mining, plant maintenance, construction, rail, heavy industrial and steel fabrication.

Utilise the convenience and power of an impact wrench. Provides fast, efficient performance while being safer to use with minimal kickback.

VersaDrive ImpactaStep Cutters have a patented non-slip, hex shank suitable for use in any standard 1/2" drill chuck for cordless or corded drills or use with a VersaDrive Rapid-Lock adaptor for use in a wide range of power tools such as magnetic drills.

- 5 drill bits in one
- Enlarge holes in material up to 12mm thick
- Safety breakthrough collar to prevent injury and damage
- Fast, smooth drilling and reaming with minimal kickback
- Specially hardened for impact wrench use
- Titanium nitride coating reduces heat and increases lubricity for extended life



Recommended Adaptors



Speeds & Feeds | PG 48



Click or Scan & See | ▶



Alpha Liquid Gold Cutting Fluid*



Click or Scan | Pack Sizes

*Alpha Liquid Gold Cutting Fluid is formulated for extreme cutting performance and is recommended for use when tapping, drilling or reaming into all metals



SET CASE
Supplied in sturdy plastic storage case

Metric Set

3 PCE

Sizes: 8 - 16, 14 - 22 & 18 - 26mm

Code: 506010-SET1

Imperial Set

3 PCE

Sizes: 5/16 - 9/16, 9/16 - 13/16 & 13/16 - 1 1/16"

Code: 506030-SET1

METRIC					HANDI PACK	
Ø mm	No. of Steps	Step Depth mm	OAL mm	WL mm	Ø included mm	CODE 1 PCE
8.0 - 16.0	5	12	107	72	8, 10, 12, 14 & 16	506010-0160
14.0 - 22.0	5	12	110	82	14, 16, 18, 20 & 22	506010-0220
18.0 - 26.0	5	12	112	84	18, 20, 22, 24 & 26	506010-0260
24.0 - 32.0	5	12	115	87	24, 26, 28, 30 & 32	506010-0360

IMPACT WRENCH	IMPACT DRIVER	HAMMER DRILL	POWER DRILL	PEDESTAL DRILL	MAG BASED DRILL
IMPACT			ROTARY		
✓	—	—	✓	✓	✓
✓	—	✗	✓	✓	✓
✓	✗	✗	—	✓	✓
✓	✗	✗	—	✓	✓

IMPERIAL					HANDI PACK	
Ø	No. of Steps	Step Depth	OAL	WL	Ø included	CODE 1 PCE
5/16 - 9/16"	5	4 3/16"			5/16, 3/8, 7/16, 1/2 & 9/16"	506030-0010
9/16 - 13/16"	5	4 5/16"			9/16, 5/8, 11/16, 3/4 & 13/16"	506030-0020
13/16 - 1 1/16"	5	4 7/16"			13/16, 7/8, 15/16, 1 & 1 1/16"	506030-0030

IMPACT WRENCH	IMPACT DRIVER	HAMMER DRILL	POWER DRILL	PEDESTAL DRILL	MAG BASED DRILL
IMPACT			ROTARY		
✓	—	—	✓	✓	✓
✓	—	✗	✓	✓	✓
✓	✗	✗	—	✓	✓

IMPACT RATED

ROTARY RATED

Impact Step Drills

IDEAL FOR

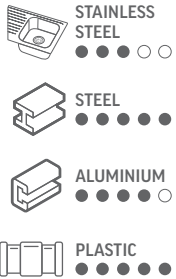

FAST PERFORMANCE



LONG LIFE

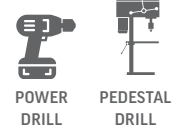

11mm
NON-SLIP
SHANK

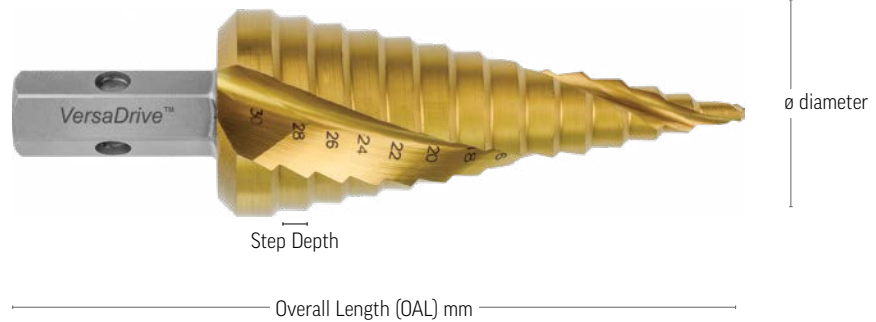

5mm
MAX.
MATERIAL
THICKNESS

The first step drill optimised for use with impact wrenches and impact drivers allowing the user to create holes in seconds.

Featuring a spiral flute design with self-starting drill tip, for fast, smooth drilling with a rotary drill or impact wrench and market-leading 5mm thick drilling capacity.

VersaDrive Step Drills have a patented non-slip, hex shank suitable for use in any standard 1/2" drill chuck for cordless or corded drills or used with a VersaDrive Rapid-Lock adaptor for use in a wide range of power tools such as magnetic drills.

- Specially hardened for impact wrench use
- Market-leading 5mm thick drilling capacity
- Precision ground flutes for easy chip clearance with 135° split point angle for easy starting and accuracy
- Spiral flute design, for fast, smooth drilling with minimal kickback
- Titanium nitride coating reduces heat and increases lubricity for extended life
- High strength, non-slip shank design



HANDI PACK
Supplied in hangleable plastic pack

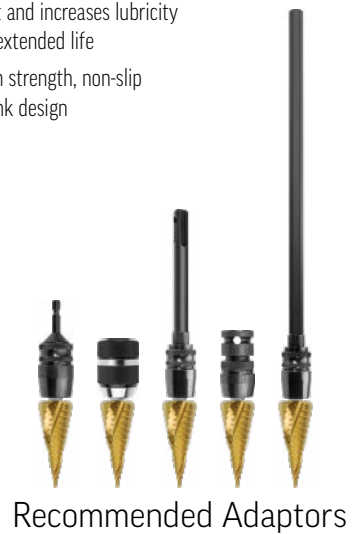

Speeds & Feeds | PG 49



Click or Scan & See | ▶



Alpha
Liquid Gold
Cutting Fluid*



Click or Scan | Pack Sizes

*Alpha Liquid Gold Cutting Fluid is formulated for extreme cutting performance and is recommended for use when tapping, drilling or reaming into all metals



SET CASE
Supplied in sturdy plastic storage case

Metric Set

3 PCE

Sizes: 4 - 12, 4 - 22 & 4 - 30mm

Code: 505020-SET1

4 PCE

Sizes: 4 - 12, 4 - 22,
4 - 30 & 6 - 40mm

Code: 505020-SET2

Imperial Set

3 PCE

Sizes: 3/16 - 1/2, 3/16 - 7/8 & 1/4 - 1 3/8"

Code: 505030-SET1

METRIC						HANDI PACK
ø mm	No. of Steps	Step Depth mm	OAL mm	WL mm	ø included mm	CODE 1 PCE
4.0 - 12.0	5	5	75	47	4, 6, 8, 10 & 12	505020-0120
4.0 - 22.0	9	5	86	58	4, 6, 8, 10, 12, 14, 16, 18 & 22	505020-0220
4.0 - 30.0	13	5	105	77	4, 6, 8, 10, 12, 14, 16, 18, 22, 24, 26, 28 & 30	505020-0300
6.0 - 40.0	11	6	101	72	6, 8, 10, 12, 16, 20, 25, 29, 32, 36 & 40	505020-0400

IMPACT WRENCH	IMPACT DRIVER	HAMMER DRILL	POWER DRILL	PEDESTAL DRILL	MAG BASED DRILL
IMPACT			ROTARY		
✓	✓	✗	✓	✓	✓
✓	✓	✗	✓	✓	✓
✓	✓	✗	✓	✓	✓
—	✗	✗	✓	✓	✓

IMPERIAL						HANDI PACK
ø	No. of Steps	Step Depth	OAL	WL	ø included	CODE 1 PCE
3/16 - 1/2"	6	3/16"	2 43/64"	1 1/2"	3/16, 1/4, 5/16, 3/8, 7/16 & 1/2"	505030-0010 (📞)
3/16 - 7/8"	12	3/16"	3 15/32"	2 9/32"	3/16, 1/4, 5/16, 3/8, 7/16, 1/2, 9/16, 5/8, 11/16, 3/4, 13/16 & 7/8"	505030-0020 (📞)
1/4 - 1 3/8"	10	3/16"	3 5/32"	1 31/32"	1/4, 3/8, 1/2, 5/8, 3/4, 7/8, 1, 1 1/8, 1 1/4 & 1 3/8"	505030-0030 (📞)

IMPACT WRENCH	IMPACT DRIVER	HAMMER DRILL	POWER DRILL	PEDESTAL DRILL	MAG BASED DRILL
IMPACT			ROTARY		
✓	✓	✗	✓	✓	✓
✓	✓	✗	✓	✓	✓
✓	✓	✗	✓	✓	✓

IMPACT RATED

ROTARY RATED

Impact Reamers

11mm
NON-SLIP
SHANK

Working Length 1 (WL1) mm

Working Length 2 (WL2) mm



Overall Length (OAL) mm



To maximise tool life do not attempt to increase the existing hole diameter beyond 2-3mm. If a larger, finished hole size is required, then the next size reamer should be used to 'step up' until the finished hole diameter is reached.

IDEAL FOR



FAST PERFORMANCE



LONG LIFE

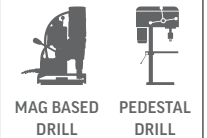

34-61mm
MAX. MATERIAL THICKNESS

VersaDrive Reamers are the perfect hole alignment and enlarging tools for metalworkers and erectors for keeping the job moving when a hole is misaligned or the incorrect size for the fixing.

Featuring a specially designed 6-flute cutting geometry and Titanium coating, VersaDrive Reamers are fully impact-rated and perform fastest when used with an impact wrench providing ultimate cutting performance with virtually no power tool kickback.

VersaDrive Reamers have a patented non-slip, hex shank suitable for use in any standard 1/2" drill chuck for cordless or corded drills or used with a VersaDrive Rapid-Lock adaptor for use in a wide range of power tools such as magnetic drills.

- Specially hardened for impact wrench use
- Precision 6-flute design for smooth cutting
- Safer reaming with minimal kickback
- High grade tool steel for high accuracy and long life
- Titanium nitride coating reduces heat and increases lubricity for extended life
- Use on impact or rotary
- High strength, non-slip shank design



HANDI PACK
Supplied in hangable plastic pack



Recommended Adaptors



Speeds & Feeds | PG 50



Click or Scan & See |



Alpha Liquid Gold Cutting Fluid*



Click or Scan | Pack Sizes

*Alpha Liquid Gold Cutting Fluid is formulated for extreme cutting performance and is recommended for use when tapping, drilling or reaming into all metals



SET CASE

Supplied in sturdy plastic storage case

Metric Set

3 PCE

Sizes: 14, 18, & 22mm

Code: 501030-3SET

4 PCE

Sizes: 12, 14, 18, 22, & 26mm

Code: 501030-SET

Imperial Set

3 PCE

Sizes: 1/2, 5/8 & 3/4"

Code: 501040-3SET

4 PCE

Sizes: 1/2, 5/8, 3/4, 7/8 & 1 1/16"

Code: 501040-SET

METRIC					HANDI PACK
Ø mm	Ø d1 mm	OAL mm	WL1 mm	WL2 mm	CODE 1 PCE
8.0	4.4	108	34	36	501030-0080
10.0	6.0	108	34	36	501030-0100
12.0	7.1	144	43	59	501030-0120
14.0	7.5	144	52	50	501030-0140
16.0	8.0	152	58	56	501030-0160
18.0	9.4	170	58	56	501030-0180
20.0	11.2	178	61	65	501030-0200
21.0	12.3	185	61	66	501030-0210
22.0	13.2	185	61	66	501030-0220
24.0	15.1	185	63	64	501030-0240
26.0	15.9	185	61	64	501030-0260

IMPERIAL					HANDI PACK	
Ø	Ø mm	Ø d1	OAL	WL1	WL2	CODE 1 PCE
1/2"	12.7	19/64"	5 1/2"	1 15/16"	2 1/16"	501040-0040
9/16"	14.3	9/32"	5 1/2"	2 1/16"	1 15/16"	501040-0050
5/8"	15.9	5/16"	6"	2 11/64"	2 21/64"	501040-0060
11/16"	17.5	3/8"	6"	2 1/4"	2 1/4"	501040-0070
3/4"	19.05	13/32"	7"	2 31/64"	2 33/64"	501040-0080
13/16"	20.63	15/32"	7"	2 33/64"	2 31/64"	501040-0085
7/8"	22.2	17/32"	7"	2 19/32"	2 13/32"	501040-0090
15/16"	23.8	19/32"	7"	2 43/64"	2 21/64"	501040-0100
1"	25.4	5/8"	7"	2 43/64"	2 21/64"	501040-0110
1 1/16"	27.0	45/64"	7"	2 9/16"	2 7/16"	501040-0120

IMPACT WRENCH	IMPACT DRIVER	HAMMER DRILL	POWER DRILL	PEDESTAL DRILL	MAG BASED DRILL
IMPACT		ROTARY			
✓	✓	✓	✓	✓	✓
✓	✓	✓	✓	✓	✓
✓	✓	✓	✓	✓	✓
✓	✓	✓	—	✓	✓
✓	✓	✓	—	✓	✓
✓	—	✓	—	✓	✓
✓	—	✓	—	✓	✓
✓	—	✗	—	✓	—
✓	—	✗	—	✓	—
✓	—	✗	—	✓	—

IMPACT WRENCH	IMPACT DRIVER	HAMMER DRILL	POWER DRILL	PEDESTAL DRILL	MAG BASED DRILL
IMPACT		ROTARY			
✓	✓	✓	✓	✓	✓
✓	✓	✓	✓	✓	✓
✓	✓	✓	✓	✓	✓
✓	—	✓	✓	✓	✓
✓	—	✓	—	✓	✓
✓	—	✓	—	✓	✓
✓	—	✗	—	✓	—
✓	—	✗	—	✓	—
✓	—	✗	—	✓	—
✓	—	✗	—	✓	—

IMPACT RATED

ROTARY RATED

15x
FASTER

faster performance than tapping by hand

IDEAL FOR

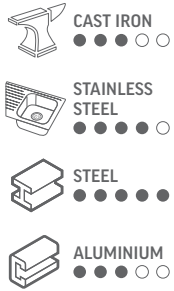

FAST PERFORMANCE



LONG LIFE



HANDI PACK
Supplied in hangable plastic pack

ImpactaTaps®

11mm
NON-SLIP
SHANK

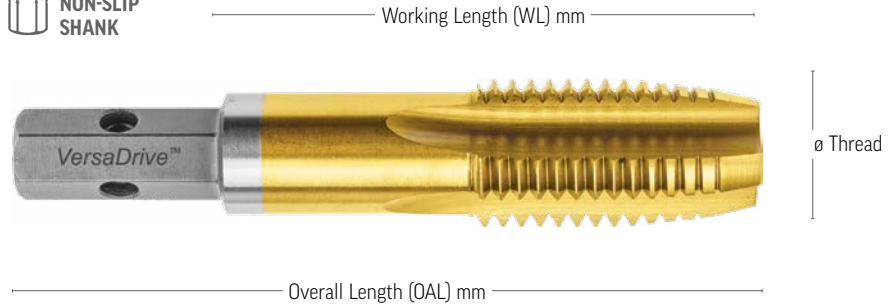

CUT DEPTH 3xD MAX. 50mm

VersaDrive ImpactaTaps® are the first and only range of taps that are suitable to be driven by impact wrenches and impact drivers, providing at least 15x faster performance than tapping by hand.

A specially designed twin-lead, cutting geometry - the dual hardening process with Titanium coating provides a fantastic solution for tapping holes in steel.

VersaDrive ImpactaTaps® have a patented non-slip, hex shank suitable for use in any standard 1/2" drill chuck for cordless or corded drills (up to M10) or used with a VersaDrive Rapid-Lock adaptor for use in a wide range of power tools such as magnetic drills. They can even be used by hand in a socket wrench.

- Specially hardened for impact wrench use
- Precision ground for high accuracy to create the perfect tapped hole
- Safer tapping with minimal kickback
- High grade tool steel for high performance and long life
- Titanium nitride coating reduces heat and increases lubricity for extended life
- High strength, non-slip shank design



Recommended Adaptors



Speeds & Feeds | PG 53



Click or Scan & See



Alpha Liquid Gold Cutting Fluid*



Click or Scan | Pack Sizes

*Alpha Liquid Gold Cutting Fluid is formulated for extreme cutting performance and is recommended for use when tapping, drilling or reaming into all metals



9 PCE
TurboTip® Drill Bit & ImpactaTaps® Set

- 4 x TurboTip® Drill Bits:
6.8, 8.5, 10.5 & 14mm
- 4 x ImpactaTaps® Metric Coarse:
M8, M10, M12, M16
- 1 x 1/2" Impact Wrench Adaptor

Code: 328015-SET1

ImpactaTaps® Metric Coarse

METRIC COARSE					HANDI PACK
Thread ø	Pitch mm	OAL mm	WL mm	Tap Hole Size mm	CODE 1 PCE
M5	0.80	55	18	4.2	308010-0050
M6	1.00	55	20	5.0	308010-0060
M8	1.25	60	22	6.8	308010-0080
M10	1.50	70	24	8.5	308010-0100
M12	1.75	80	29	10.2	308010-0120
M14	2.00	90	32	12.0	308010-0140
M16	2.00	90	32	14.0	308010-0160
M18	2.50	100	37	15.5	308010-0180
M20	2.50	100	37	17.5	308010-0200
M24	3.00	110	45	21.0	308010-0240
M27	3.00	130	48	24.0	308010-0270
M30	3.50	130	48	26.5	308010-0300

	IMPACT			ROTARY		
✓	✓	✗	✓	✓	✓	
✓	✓	✗	✓	✓	✓	
✓	✓	✗	✓	✓	✓	
✓	✓	✗	✓	✓	✓	
✓	✓	✗	✓	✓	✓	
✓	✗	✗	✗	✓	✓	
✓	✗	✗	✗	✓	✓	
✓	✗	✗	✗	✓	✓	
✓	✗	✗	✗	✓	✓	
✓	✗	✗	✗	✓	✓	
✓	✗	✗	✗	✓	✓	
✓	✗	✗	✗	✓	✓	



Metric Coarse Set

- 5 PCE**
Sizes: M6, M8, M10, M12 & M16

Code: 308010-SET1

- 4 PCE**
Sizes: M12, M16, M20 & M24

Code: 308010-SET2

IMPACT RATED

ROTARY RATED

15x
FASTER

faster performance than tapping by hand

ImpactaTaps® Metric Coarse Long Series



- Spiral Point Taps for fast chip ejection in through holes

METRIC COARSE						HANDI PACK
Thread ø	Pitch mm	OAL mm	WL mm	Tap Hole Size mm	Max Cutting Depth mm	CODE 1 PCE
M8	1.25	140	45	6.8	112	308015-0080
M10	1.50	155	50	8.5	127	308015-0100
M12	1.75	180	55	10.2	152	308015-0120
M16	2.0	200	65	14.0	172	308015-0160
M20	2.5	230	70	17.5	202	308015-0200
M24	3.0	260	75	21.0	232	308015-0240

IMPACT WRENCH	IMPACT DRIVER	HAMMER DRILL	POWER DRILL	PEDESTAL DRILL	MAG BASED DRILL
IMPACT			ROTARY		
✓	✓	✗	✓	✓	✓
✓	✓	✗	✓	✓	✓
✓	✓	✗	✓	✓	✓
✓	✗	✗	✗	✓	✓
✓	✗	✗	✗	✓	✓
✓	✗	✗	✗	✓	✓

IMPACT RATED

ROTARY RATED

15x
FASTER

faster performance than tapping by hand



- Used for tapping holes used in galvanised fixings

METRIC COARSE						HANDI PACK
Thread ø	Pitch mm	OAL mm	WL mm	Tap Hole Size mm	CODE 1 PCE	
M5 + 0.4	0.80	55	18	4.2	308020-0050	
M6 + 0.4	1.00	55	20	5.0	308020-0060	
M8 + 0.4	1.25	60	22	6.8	308020-0080	
M10 + 0.4	1.50	70	24	8.5	308020-0100	
M12 + 0.4	1.75	80	29	10.2	308020-0120	
M16 + 0.4	2.00	90	32	14.0	308020-0160	
M20 + 0.4	2.50	100	37	17.5	308020-0200	
M24 + 0.4	3.00	110	45	21.0	308020-0240	
M30 + 0.4	3.50	130	48	26.5	308020-0300	

IMPACT WRENCH	IMPACT DRIVER	HAMMER DRILL	POWER DRILL	PEDESTAL DRILL	MAG BASED DRILL
IMPACT			ROTARY		
✓	✓	✗	✓	✓	✓
✓	✓	✗	✓	✓	✓
✓	✓	✗	✓	✓	✓
✓	✓	✗	✓	✓	✓
✓	✓	✗	✓	✓	✓
✓	✗	✗	✗	✓	✓
✓	✗	✗	✗	✓	✓
✓	✗	✗	✗	✓	✓
✓	✗	✗	✗	✓	✓



Metric Coarse Oversized Set

6 PCE

Sizes: M5, M6, M8, M10, M12 & M16

Code: 308020-SET1



Speeds & Feeds | PG 53



Click or Scan & See | ▶



Alpha Liquid Gold Cutting Fluid*



Click or Scan | Pack Sizes

*Alpha Liquid Gold Cutting Fluid is formulated for extreme cutting performance and is recommended for use when tapping, drilling or reaming into all metals

IMPACT RATED

ROTARY RATED

15x
FASTER

faster performance than tapping by hand

ImpactaTaps® Metric Fine



METRIC FINE					HANDI PACK
Thread ø	Pitch mm	OAL mm	WL mm	Tap Hole Size mm	CODE 1 PCE
MF6	0.75	60	19	5.2	308030-0060
MF8	1.00	70	22	7.0	308030-0080
MF10	1.25	70	24	8.8	308030-0100
MF12	1.50	80	29	10.5	308030-0120
MF16	1.50	90	32	14.5	308030-0160
MF18	1.50	100	37	16.5	308030-0180
MF20	1.50	100	37	18.5	308030-0200
MF24	1.50	120	92	22.5	308030-0240



IMPACT			ROTARY		
IMPACT WRENCH	IMPACT DRIVER	HAMMER DRILL	POWER DRILL	PEDESTAL DRILL	MAG BASED DRILL
✓	✓	✗	✓	✓	✓
✓	✓	✗	✓	✓	✓
✓	✓	✗	✓	✓	✓
✓	✓	✗	✓	✓	✓
✓	✗	✗	✗	✓	✓
✓	✗	✗	✗	✓	✓
✓	✗	✗	✗	✓	✓
✓	✗	✗	✗	✓	✓

VERSADRIVE

IMPACT RATED

ROTARY RATED

15x
FASTER

faster performance than tapping by hand

ImpactaTaps® UNC Unified National Coarse



IMPERIAL UNC					HANDI PACK
Thread ø	Pitch mm	OAL mm	WL mm	Tap Hole Size mm	CODE 1 PCE
1/4"	20	58	20	5.10	308050-0010
5/16"	18	60	22	6.60	308050-0020
3/8"	16	70	24	8.00	308050-0030
1/2"	13	80	29	10.80	308050-0040
5/8"	11	90	32	13.50	308050-0050
3/4"	10	100	37	16.50	308050-0060
7/8"	9	105	40	19.50	308050-0065
1"	8	110	45	22.25	308050-0070



IMPACT			ROTARY		
IMPACT WRENCH	IMPACT DRIVER	HAMMER DRILL	POWER DRILL	PEDESTAL DRILL	MAG BASED DRILL
✓	✓	✗	✓	✓	✓
✓	✓	✗	✓	✓	✓
✓	✓	✗	✓	✓	✓
✓	✓	✗	✓	✓	✓
✓	✗	✗	✗	✓	✓
✓	✗	✗	✗	✓	✓
✓	✗	✗	✗	✓	✓
✓	✗	✗	✗	✓	✓



UNC Set

5 PCE

Sizes: 1/4, 5/16, 3/8, 1/2 & 5/8"

Code: 308050-SET1

4 PCE

Sizes: 1/2, 5/8, 3/4 & 1"

Code: 308050-SET2

IMPACT RATED

ROTARY RATED

**15x
FASTER**

faster performance
than tapping by hand

ImpactaTaps® BSW British Standard Whitworth



IMPERIAL BSW					HANDI PACK
Thread ø	TPI	OAL mm	WL mm	Tap Hole Size mm	CODE 1 PCE
1/4"	20	58	20	5.1	308060-0010
5/16"	18	60	22	6.5	308060-0015
3/8"	16	70	24	7.9	308060-0020
1/2"	12	80	29	10.5	308060-0030
5/8"	11	90	32	13.5	308060-0040
3/4"	10	100	37	16.25	308060-0050
1"	8	110	45	22.0	308060-0060

	IMPACT WRENCH	IMPACT DRIVER	HAMMER DRILL	POWER DRILL	PEDESTAL DRILL	MAG BASED DRILL
	IMPACT			ROTARY		
	✓	✓	✗	✓	✓	✓
	✓	✓	✗	✓	✓	✓
	✓	✓	✗	✓	✓	✓
	✓	✓	✗	✓	✓	✓
	✓	✗	✗	✗	✓	✓
	✓	✗	✗	✗	✓	✓
	✓	✗	✗	✗	✓	✓

IMPACT RATED

ROTARY RATED

**15x
FASTER**

faster performance
than tapping by hand

ImpactaTaps® BSPF British Standard Pipe Fitting



IMPERIAL BSPF					HANDI PACK
Thread ø	TPI	OAL mm	WL mm	Tap Hole Size mm	CODE 1 PCE
1/8"	28	70	24	8.8	308070-0010
1/4"	19	90	32	11.8	308070-0020
3/8"	19	90	32	15.25	308070-0030
1/2"	14	100	37	19.0	308070-0040
5/8"	14	100	37	21.0	308070-0050
3/4"	14	100	37	24.5	308070-0060
1"	11	110	45	30.75	308070-0070

	IMPACT WRENCH	IMPACT DRIVER	HAMMER DRILL	POWER DRILL	PEDESTAL DRILL	MAG BASED DRILL
	IMPACT			ROTARY		
	✓	✓	✗	✓	✓	✓
	✓	✓	✗	✓	✓	✓
	✓	✓	✗	✓	✓	✓
	✓	✓	✗	✓	✓	✓
	✓	✗	✗	✗	✓	✓
	✓	✗	✗	✗	✓	✓
	✓	✗	✗	✗	✓	✓



Speeds & Feeds | PG 53



Click or Scan & See |



Alpha
Liquid Gold
Cutting Fluid*



Click or Scan | Pack Sizes

*Alpha Liquid Gold Cutting Fluid is formulated for extreme cutting performance and is recommended for use when tapping, drilling or reaming into all metals

IMPACT RATED

ROTARY RATED

Spiral Flute Tap Metric Coarse



VERSADRIVE

METRIC COARSE					HANDI PACK
Thread ø	Pitch mm	OAL mm	WL mm	Tap Hole Size mm	CODE 1 PCE
M6	1.00	58	20	5.0	309010-0060
M8	1.25	60	22	6.8	309010-0080
M10	1.50	70	24	8.5	309010-0100
M12	1.75	80	29	10.2	309010-0120
M16	2.00	90	32	14.0	309010-0160
M20	2.50	100	37	17.5	309010-0200
M24	3.00	110	45	21.0	309010-0240
M30	3.50	130	48	26.5	309010-0300

IMPACT WRENCH	IMPACT DRIVER	HAMMER DRILL	POWER DRILL	PEDESTAL DRILL	MAG BASED DRILL
IMPACT			ROTARY		
✓	✓	✗	✓	✓	✓
✓	✓	✗	✓	✓	✓
✓	✓	✗	✓	✓	✓
✓	✓	✗	✓	✓	✓
✓	✗	✗	✗	✓	✓
✓	✗	✗	✗	✓	✓
✓	✗	✗	✗	✓	✓

Spiral Flute Tap Metric Coarse Set

5 PCE

Sizes: M6, M8, M10, M12 & M16

Code: 309010-SET

4 PCE

Sizes: M12, M16, M20 & M24

Code: 309010-SET2

IMPACT RATED

ROTARY RATED

Spiral Flute Tap UNC



IMPERIAL UNC					HANDI PACK
Thread ø	TPI	OAL mm	WL mm	Tap Hole Size mm	CODE 1 PCE
1/4"	20	58	20	5.1 #7	309020-0010
5/16"	18	60	22	6.6 #F	309020-0020
3/8"	16	70	24	8.0 5/16"	309020-0030
1/2"	13	80	29	10.8 27/64"	309020-0040
5/8"	11	90	32	13.5 17/32"	309020-0050
3/4"	10	100	37	16.5 21/32"	309020-0060
7/8"	9	105	40	19.5 49/64"	309020-0065
1"	8	110	45	22.25 7/8"	309020-0070
1-1/4"	7	128	41	28.17 1 7/64"	309020-0110

IMPACT WRENCH	IMPACT DRIVER	HAMMER DRILL	POWER DRILL	PEDESTAL DRILL	MAG BASED DRILL
IMPACT			ROTARY		
✓	✓	✗	✓	✓	✓
✓	✓	✗	✓	✓	✓
✓	✓	✗	✓	✓	✓
✓	✓	✗	✓	✓	✓
✓	✗	✗	✗	✓	✓
✓	✗	✗	✗	✓	✓
✓	✗	✗	✗	✓	✓
✓	✗	✗	✗	✓	✓

Spiral Flute Tap UNC Set

5 PCE

Sizes: 1/4, 5/16, 3/8, 1/2 & 5/8"

Code: 309020-SET1

3 PCE

Sizes: 1/2, 3/4 & 1"

Code: 309020-SET2





IMPACT RATED

ROTARY RATED

Combi Drill Taps

Drill & Tap in
ONE EASY OPERATION
with an
Impact Wrench



IDEAL FOR

-  CAST IRON ●●●○
-  STAINLESS STEEL ●●●○
-  STEEL ●●●●●
-  ALUMINIUM ●●●○

FAST PERFORMANCE

-  IMPACT WRENCH
-  IMPACT DRIVER

LONG LIFE

-  PEDESTAL DRILL
-  MAG BASED DRILL

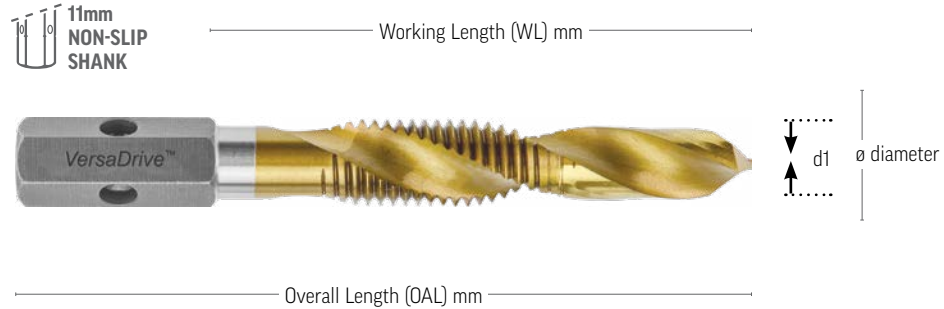

VersaDrive Combi Drill Taps are a time-saving solution for pilot drilling and tapping in one easy operation. The Titanium coating provides wear resistance and faster-cutting performance.

VersaDrive Combi Drill Taps have a patented non-slip, hex shank suitable for use in any standard 1/2" drill chuck for cordless or corded drills or used with a VersaDrive Rapid-Lock adaptor for use in a wide range of power tools such as magnetic drills.

Recommended for use with impact drivers for high drilling and tapping productivity.

- Specially hardened for impact wrench use
- Drill and tap in one easy operation
- Safer tapping with minimal kickback
- Ground flute twist drill and spiral tap creates the perfect tapped hole
- High grade tool steel for high accuracy and long life
- Titanium nitride coating reduces heat and increases lubricity for extended life
- High strength, non-slip shank design



HANDI PACK
Supplied in hangable plastic pack



Recommended Adaptors



Speeds & Feeds | PG 54



Click or Scan & See | ▶



Alpha Liquid Gold Cutting Fluid*



Click or Scan | Pack Sizes

*Alpha Liquid Gold Cutting Fluid is formulated for extreme cutting performance and is recommended for use when tapping, drilling or reaming into all metals



Metric Course Set

5 PCE

Sizes: M5, M6, M8, M10 & M12

Code: 301125-SET1

Imperial UNC Set

4 PCE

Sizes: 1/4, 5/16, 3/8 & 1/2"

Code: 301126-SET1

VERSADRIVE

METRIC						HANDI PACK
Thread ø	Pitch mm	ø mm	OAL mm	WL mm	Max tapping depth with impact wrench	CODE 1 PCE
M3	0.50	2.5	55	6	3mm	301125-0030
M4	0.70	3.3	60	9	4mm	301125-0040
M5	0.80	4.2	71	13	5mm	301125-0050
M6	1.00	5.0	75	17	6mm	301125-0060
M8	1.25	6.8	82	20	8mm	301125-0080
M10	1.50	8.5	92	25	10mm	301125-0100
M12	1.75	10.2	103	31	12mm	301125-0120

IMPACT WRENCH	IMPACT DRIVER	HAMMER DRILL	POWER DRILL	PEDESTAL DRILL	MAG BASED DRILL
IMPACT			ROTARY		
✓	✓	✗	✓	✓	✓
✓	✓	✗	✓	✓	✓
✓	✓	✗	✓	✓	✓
✓	✓	✗	✓	✓	✓
✓	✓	✗	—	✓	✓
✓	—	✗	—	✓	✓
✓	—	✗	—	✓	✓

IMPERIAL UNC						HANDI PACK
Thread ø	TPI	OAL mm	WL mm	Max tapping depth with impact wrench	CODE 1 PCE	
4 UNC	40	3/32	2 11/64	15/64"	3/32"	301126-0010
6 UNC	32	7/64	2 23/64	23/64"	1/8"	301126-0020
8 UNC	32	9/64	2 23/64	23/64"	5/32"	301126-0030
10 UNC	24	5/32	2 51/64	33/64"	13/64"	301126-0040
1/4"	20	13/64	2 61/64	19/32"	1/4"	301126-0050
5/16"	18	1/4	3 15/64	45/64"	5/16"	301126-0060
3/8"	16	5/16	3 5/8	55/64"	3/8"	301126-0070
1/2"	13	27/64	4 1/16	1 7/64"	1/2"	301126-0080





IMPACT WRENCH	IMPACT DRIVER	HAMMER DRILL	POWER DRILL	PEDESTAL DRILL	MAG BASED DRILL
IMPACT			ROTARY		
✓	✓	✗	✓	✓	✓
✓	✓	✗	✓	✓	✓
✓	✓	✗	✓	✓	✓
✓	✓	✗	✓	✓	✓
✓	✓	✗	—	✓	✓
✓	—	✗	—	✓	✓
✓	—	✗	—	✓	✓

ROTARY RATED

Drill & Tap in one easy operation with

RIGID MACHINE TOOLS

IDEAL FOR

-  **CAST IRON** ●●●○
-  **STAINLESS STEEL** ●●●●○
-  **STEEL** ●●●●●
-  **ALUMINIUM** ●●●○

FAST PERFORMANCE



LONG LIFE

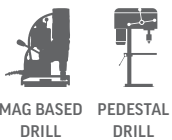

Heavy Duty ImpactaTaps® Drill Taps

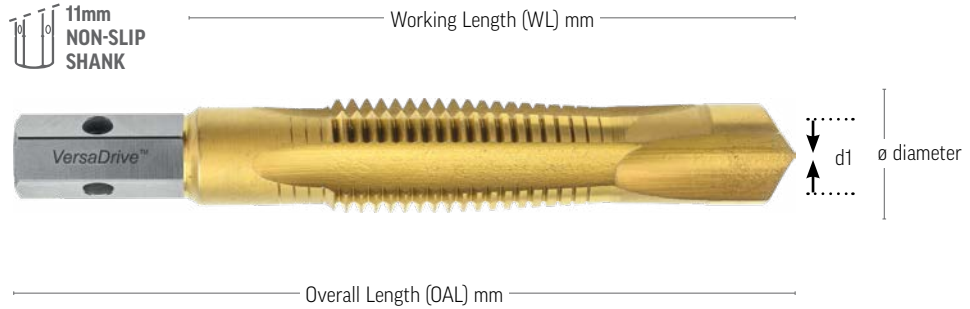

VersaDrive Heavy Duty ImpactaTaps® Drill Taps are an industrial metalwork or fabrication tool for drilling and tapping heavy steel in one easy operation.

Primarily they are designed to be used with a reversible magnet drill, although they can also be adapted for use with an impact wrench to enlarge and tap existing holes.

With a drill point optimised for use in fixed drilling machines like magnetic drills or pillar drills, these are not recommended for use in a cordless drill. Where they are used with an impact wrench to enlarge and tap holes pilot drilling is recommended with a separate drill bit.

- Specially hardened for impact wrench use (check application guide page 33)
- Drill point optimised for use in fixed drilling machines including mag-based drills and pedestal drills
- Unique dual-point starting angle for easy alignment and fast cut
- Fast tapping with minimal kick-back
- Straight flute chipbreaker action for automatic chip clearance when impact tapping (check application guide)
- High-grade tool steel for high accuracy and long life
- Titanium nitride coating reduces heat and increases lubricity for extended life
- High strength, non-slip shank design



HANDI PACK
Supplied in hangable plastic pack



Recommended Adaptors



Speeds & Feeds | **PG 54**



Click or Scan & See | 



Alpha **Liquid Gold** Cutting Fluid*



Click or Scan | **Pack Sizes** 

*Alpha Liquid Gold Cutting Fluid is formulated for extreme cutting performance and is recommended for use when tapping, drilling or reaming into all metals



Metric Course Set

4 PCE

Sizes: M12, M16, M20 & M24

Code: 301130-SET1

Imperial UNC Set

4 PCE

Sizes: 1/2, 5/8, 3/4 & 1"

Code: 301140-SET1

VERSADRIVE

METRIC COARSE						HANDI PACK
Thread ø	Pitch mm	ø mm	OAL mm	WL mm	Max tapping depth	CODE 1 PCE
M8	1.25	6.8	100	30	20mm	301130-0080
M10	1.50	8.5	105	30	20mm	301130-0100
M12	1.75	10.2	117	35	25mm	301130-0120
M16	2.00	14	117	37	25mm	301130-0160
M20	2.50	17.5	135	40	35mm	301130-0200
M24	3.00	21	148	45	40mm	301130-0240

IMPACT WRENCH	IMPACT DRIVER	HAMMER DRILL	POWER DRILL	PEDESTAL DRILL	MAG BASED DRILL
IMPACT			ROTARY		
⊖	⊖	⊗	⊖	✓	✓
⊖	⊖	⊗	⊖	✓	✓
⊖	⊗	⊗	⊖	✓	✓
⊖	⊗	⊗	⊗	✓	✓
⊖	⊗	⊗	⊗	✓	✓
⊖	⊗	⊗	⊗	✓	✓

IMPERIAL UNC						HANDI PACK
Thread ø	TPI	OAL mm	WL mm	Max tapping depth with impact wrench	CODE 1 PCE	
1/2"	13	27/64	4 23/32	1 3/8	1	301140-0001
5/8"	11	17/32	5 1/8	1 29/64	1	301140-0002
3/4"	10	21/32	5 33/64	1 37/64	1 3/8	301140-0003
1"	8	7/8	6 19/64	1 49/64	1 37/64	301140-0005

IMPACT WRENCH	IMPACT DRIVER	HAMMER DRILL	POWER DRILL	PEDESTAL DRILL	MAG BASED DRILL
IMPACT			ROTARY		
⊖	⊗	⊗	⊖	✓	✓
⊖	⊗	⊗	⊗	✓	✓
⊖	⊗	⊗	⊗	✓	✓
⊖	⊗	⊗	⊗	✓	✓

IMPACT RATED

ROTARY RATED

ULTIMATE PRECISION

for Drilled & Countersunk Holes

IDEAL FOR

- CAST IRON ●●●●○
- STAINLESS STEEL ●●●●○
- STEEL ●●●●●
- ALUMINIUM ●●●●○
- PLASTIC ●●●●●

FAST PERFORMANCE

- IMPACT WRENCH
- IMPACT DRIVER

LONG LIFE

- PEDESTAL DRILL
- MAG BASED DRILL



HANDI PACK
Supplied in hangable plastic pack

Combination DrillSinks

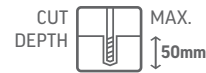

The VersaDrive Combination DrillSink is an innovative combined drilling and countersinking tool to save metalworkers time and increase hole accuracy by drilling and then countersinking fixing holes in one operation.

This combination tool provides perfect countersinking accuracy every time by locating the drilled hole in perfect alignment to the countersink. This helps prevent tool chatter and blunting commonly found with standard countersinks.

VersaDrive Combination DrillSinks have a patented non-slip, hex shank suitable for use in any standard 1/2" drill chuck for cordless or corded drills or used with a VersaDrive Rapid-Lock adaptor for use in a wide range of power tools such as magnetic drills.

- Drill and countersink in one easy operation
- Concentricity creates the perfect countersink and leaves no sharp edges
- Unique combination prevents chattering
- Precision ground flutes for high accuracy and long life
- High-grade tool steel
- Titanium nitride coating reduces heat and increases lubricity for extended life
- High strength, non-slip shank design



Recommended Adaptors



Speeds & Feeds | PG 55



Click or Scan & See



Alpha Liquid Gold Cutting Fluid*



Click or Scan | Pack Sizes

*Alpha Liquid Gold Cutting Fluid is formulated for extreme cutting performance and is recommended for use when tapping, drilling or reaming into all metals



Metric Set

4 PCE

Sizes: 8, 10, 12 & 14mm

Code: 603070-SET4

VERSADRIVE

METRIC				HANDI PACK
Ø mm	Countersink Size	OAL mm	Countersunk Screw	CODE 1 PCE
6.8	16.5	85	M8 (Tapped)	603070-68165
8.0	12.4	96	M6	603070-08124
8.5	20.5	89	M10 (Tapped)	603070-85205
10.0	16.5	85	M8	603070-10165
10.2	25.0	93	M12 (Tapped)	603070-102250
11.0	20.5	88	M10	603070-11205
12.0	20.5	88	M10	603070-12205
13.0	25.0	92	M12	603070-13250
14.0	25.0	92	M12	603070-14250

IMPACT WRENCH	IMPACT DRIVER	HAMMER DRILL	POWER DRILL	PEDESTAL DRILL	MAG BASED DRILL
IMPACT			ROTARY		
✓	✓	✗	✓	✓	✓
✓	✓	✗	✓	✓	✓
✗	✗	✗	✓	✓	✓
✓	✓	✗	✓	✓	✓
✗	✗	✗	✓	✓	✓
✗	✗	✗	✓	✓	✓
✗	✗	✗	✓	✓	✓
✗	✗	✗	✓	✓	✓





IMPACT RATED

ROTARY RATED

1st
IMPACT RATED

countersinks in
the market



IDEAL FOR

-  CAST IRON ●●●●○
-  STAINLESS STEEL ●●●●○
-  STEEL ●●●●●
-  ALUMINIUM ●●●●○
-  PLASTIC ●●●●●

FAST PERFORMANCE

-  IMPACT WRENCH
-  IMPACT DRIVER

LONG LIFE

-  POWER DRILL
-  PEDESTAL DRILL
-  MAG BASED DRILL



HANDI PACK
Supplied in
hangable
plastic pack

3 Flute Countersinks 90°

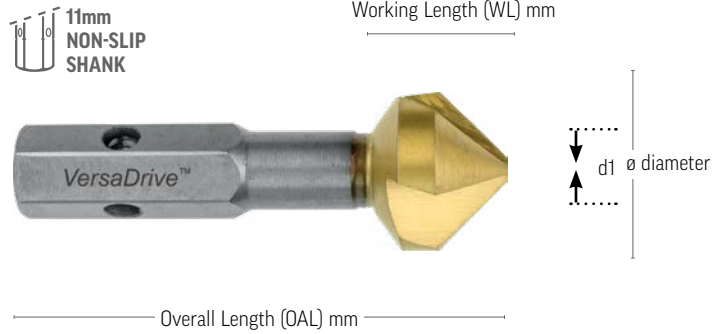

The VersaDrive Countersink is a premium quality countersink with fully ground flutes and Titanium coating to help reduce wear and blunting.

VersaDrive Countersinks have a patented non-slip, hex shank suitable for use in any standard 1/2" drill chuck for cordless or corded drills or used with a VersaDrive Rapid-Lock adaptor for use in a wide range of power tools such as magnetic drills.

Utilise the convenience and power of an impact wrench to quickly debur and countersink holes up to 16.5mm with minimal torque kickback against the operator.

- Specially hardened for impact wrench use up to \varnothing 16.5mm
- Safer use with minimal kickback
- 90° point angle for countersunk bolt heads
- High-grade tool steel for high accuracy and long life
- Titanium nitride coating reduces heat and increases lubricity for extended life
- High strength, non-slip shank design



Recommended Adaptors



Speeds & Feeds | PG 56



Click or Scan & See



Alpha
Liquid Gold
Cutting Fluid*



Click or Scan | Pack Sizes

*Alpha Liquid Gold Cutting Fluid is formulated for extreme cutting performance and is recommended for use when tapping, drilling or reaming into all metals



Metric Set

5 PCE

Sizes: 12.4, 16.5, 20.5, 25.0 & 31.0mm

Code: 603060-5SET

Imperial Set

4 PCE

Sizes: 3/8, 1/2, 5/8 & 1"

Code: 603065-5SET 

VERSADRIVE

METRIC						HANDI PACK
ø mm	ø d1 mm	OAL mm	WL mm	Countersunk Screw	Point Angle	CODE 1 PCE
6.3	1.5	45	17	M3	90°	603060-0063
8.3	2.0	50	22	M4	90°	603060-0083
10.4	2.5	50	22	M5	90°	603060-0104
12.4	2.8	56	28	M6	90°	603060-0124
16.5	3.2	60	32	M8	90°	603060-0165
20.5	3.5	63	35	M10	90°	603060-0205
25.0	3.8	67	39	M12	90°	603060-0250
31.0	4.2	71	43	M16	90°	603060-0310

IMPACT WRENCH	IMPACT DRIVER	HAMMER DRILL	POWER DRILL	PEDESTAL DRILL	MAG BASED DRILL
IMPACT			ROTARY		
✓	✓	—	✓	✓	✓
✓	✓	—	✓	✓	✓
✓	✓	—	✓	✓	✓
✓	✓	—	✓	✓	✓
—	—	—	✓	✓	✓
✗	✗	—	✓	✓	✓
✗	✗	—	✓	✓	✓
✗	✗	—	✓	✓	✓

IMPERIAL						HANDI PACK
ø	ø d1	OAL	WL	Countersunk Screw	Point Angle	CODE 1 PCE
1/4"	1/16	1 27/32	7/64	-	82°	603065-0100
3/8"	7/64	2 3/64	5/32	-	82°	603065-0200
1/2"	7/64	2 9/32	7/32	-	82°	603065-0300
5/8"	1/8	2 7/16	9/32	-	82°	603065-0400
3/4"	1/8	2 9/16	11/32	-	82°	603065-0500
1"	11/64	2 23/32	31/64	-	82°	603065-0600

IMPACT WRENCH	IMPACT DRIVER	HAMMER DRILL	POWER DRILL	PEDESTAL DRILL	MAG BASED DRILL
IMPACT			ROTARY		
✓	✓	—	✓	✓	✓
✓	✓	—	✓	✓	✓
✓	✓	—	✓	✓	✓
—	—	—	✓	✓	✓
✗	✗	—	✓	✓	✓
✗	✗	—	✓	✓	✓





ROTARY RATED

TCT Hole Cutters

**10x
LIFE**

than standard holesaws

IDEAL FOR

-  CAST IRON ●●●●●
-  STAINLESS STEEL ●●●●●
-  STEEL ●●●●●
-  ALUMINIUM ●●●●●
-  PLASTIC ●●●●●

FAST PERFORMANCE



LONG LIFE

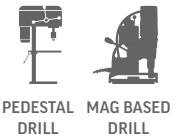

11mm
NON-SLIP
SHANK

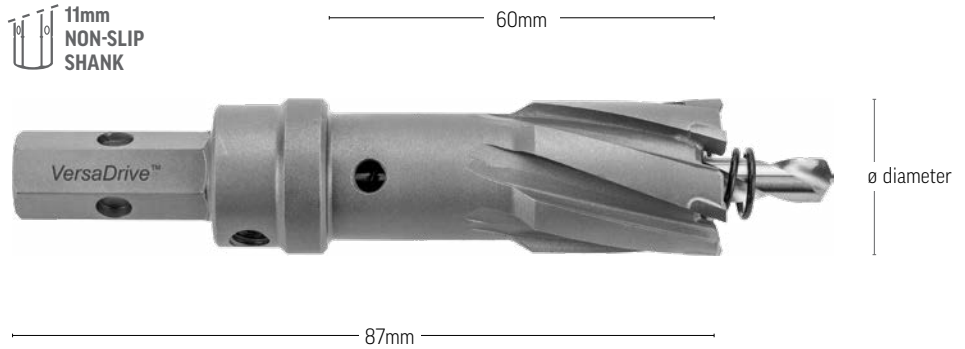

CUT DEPTH
MAX. 55mm

VersaDrive TCT Hole Cutters are a high performance solution for cutting larger diameter holes quickly and effectively.

These are rapidly becoming the go-to, alternative solution for fabricators and steel erectors needing to drill through heavy steel in locations and on projects where a rotary drill is more convenient and possibly safer than a magnetic drill.

VersaDrive TCT Hole Cutters have a patented non-slip, hex shank suitable for use in any standard 1/2" drill chuck for cordless or corded drills or used with a VersaDrive Rapid-Lock adaptor for use in a wide range of power tools such as magnetic drills.

- Massive 70mm reach with 55mm depth of cut
- Premium grade Sandvik tungsten carbide teeth for the highest performance
- Perfect for drilling in remote locations
- Ideal for use with cordless drills, drill presses and mag-based drills
- One piece design includes arbor and (replaceable) pilot drill / pin
- Can be combined with a multisink to broach and countersink in one operation (see MultiSink® Combination Tools pg 46)
- Triple cut carbide teeth
- High strength, non-slip shank design
- Spring loaded pilot drill: centers and stabilises cutter during drilling and ejects metal slug upon completion



HANDI PACK
Supplied in hangable plastic pack



Recommended Adaptors



Speeds & Feeds | PG 57



Click or Scan & See



Alpha Liquid Gold Cutting Fluid*



Click or Scan | Pack Sizes

*Alpha Liquid Gold Cutting Fluid is formulated for extreme cutting performance and is recommended for use when tapping, drilling or reaming into all metals

ROTARY RATED

Extra Long TCT Hole Cutters

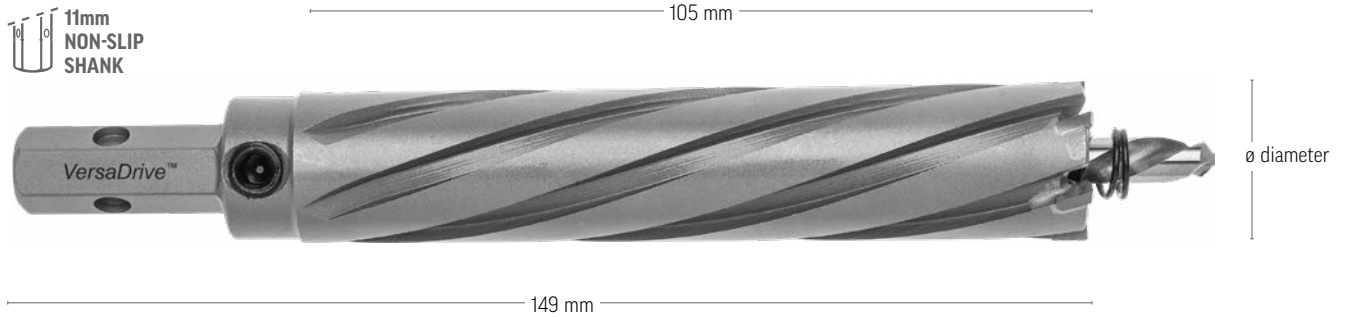

10x LIFE
than standard holesaws

IDEAL FOR

STEEL ●●●●●	ALUMINIUM ●●●●●	PLASTIC ●●●●●
CAST IRON ●●●●●	STAINLESS STEEL ●●●●●	

FAST PERFORMANCE

POWER DRILL

LONG LIFE

PEDESTAL DRILL

MAG BASED DRILL



Extra Long reach version of the popular VersaDrive Hole Cutter.

Ideal for applications where a metal plate is encountered amongst wood joists or where both sides of a steel beam require drilling.

These are rapidly becoming the go-to solution for fabricators and steel erectors needing to drill through heavy steel in locations and on projects where a rotary drill is more convenient and safe than a magnetic drill.

- Massive 120mm reach with 100mm depth of cut
- Premium quality tungsten carbide teeth for the highest performance
- Perfect for drilling box section with inaccessible sides
- Ideal for use with cordless drills, drill presses and mag-based drills
- One piece design includes arbor and (replaceable) pilot drill / pin
- Can be combined with a multisink to broach and countersink in one operation
- Triple cut carbide teeth
- High strength, non-slip shank design
- Spring loaded pilot drill: centers and stabilises cutter during drilling and ejects metal slug upon completion



HANDI PACK
Supplied in hangable plastic pack

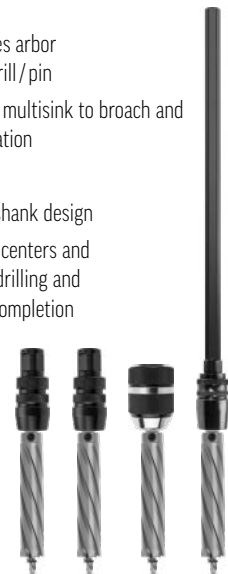

Recommended Adaptors



Speeds & Feeds | PG 57



Click or Scan & See



Alpha Liquid Gold Cutting Fluid*



Click or Scan | Pack Sizes

*Alpha Liquid Gold Cutting Fluid is formulated for extreme cutting performance and is recommended for use when tapping, drilling or reaming into all metals





Metric Set

8 PCE

Sizes: 14, 18, 20, 22, 24, 26mm,
Pilot Drill & Guide Pin

Code: 101035-SET1

VERSADRIVE

METRIC		HANDI PACK
Thread ø	Pitch mm	CODE 1 PCE
14.0	9/16"	101035-0140
17.0	11/16"	101035-0170 
18.0		101035-0180
20.0		101035-0200
21.0	13/16"	101035-0210 
22.0	7/8"	101035-0220
24.0	15/16"	101035-0240
26.0		101035-0260

IMPACT WRENCH	IMPACT DRIVER	HAMMER DRILL	POWER DRILL	PEDESTAL DRILL	MAG BASED DRILL
IMPACT			ROTARY		
✗	✗	—	✓	✓	✓
✗	✗	—	✓	✓	✓
✗	✗	—	✓	✓	✓
✗	✗	—	✓	✓	✓
✗	✗	—	✓	✓	✓
✗	✗	—	✓	✓	✓
✗	✗	—	✓	✓	✓
✗	✗	—	✓	✓	✓



2 x Extra Long Pilot Drills

6.35mm x 165mm

Supplied with ejection spring

Code: 101035P-01



2 x Extra Long Guide Pins

6.35mm x 205mm

Supplied with ejection spring

Code: 101035P-02

ROTARY RATED

CarbideMax® Ultra Broach Cutters

9x
LIFE

than uncoated
TCT cutters

IDEAL FOR

BISALLOY®
HARDOX®
RAEX®
ABRO®
STRENX®
CREUSABRO®

LONG LIFE



MAG BASED
DRILL

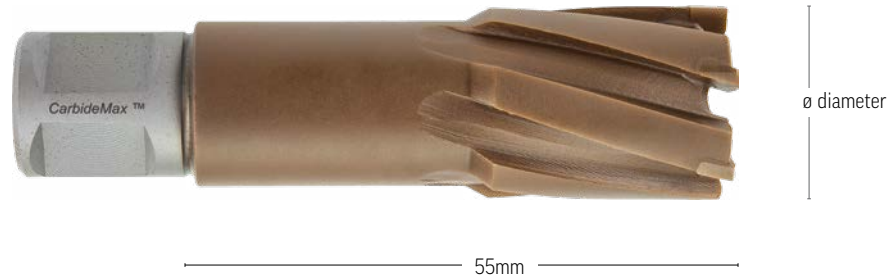
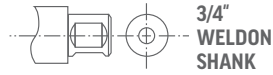

CarbideMax® Ultra Broach Cutters are specifically designed for long-life performance in the toughest broaching jobs on the planet, including Hardox® steel.

The specialist Ultra coating is proven to significantly increase tool life, making Ultra products the perfect solution in situations requiring high-performance durability, prolonged use or machining extremely hard materials.

They are produced from premium-grade materials and coated using a range of state-of-the-art, high-temperature surface coatings.

- Ultra coated for optimum performance and lifespan
- Increased wear resistance in the hardest materials
- Elaborate tool geometry for faster, quieter cutting
- Chatter free performance when used correctly
- Highest quality carbide teeth
- Individually brazed cutting teeth
- Up to 55mm depth of cut
- Standard 19.05mm Weldon shank



HANDI PACK
Supplied in
haggable
plastic pack



Best Practice Advice

PG 58



Speeds & Feeds | PG 58



Click or Scan & See



Alpha
Liquid Gold
Cutting Fluid*



Click or Scan | Pack Sizes

*Alpha Liquid Gold Cutting Fluid is formulated for extreme cutting performance and is recommended for use when tapping, drilling or reaming into all metals

ROTARY RATED

Extra Long CarbideMax® Ultra Broach Cutters

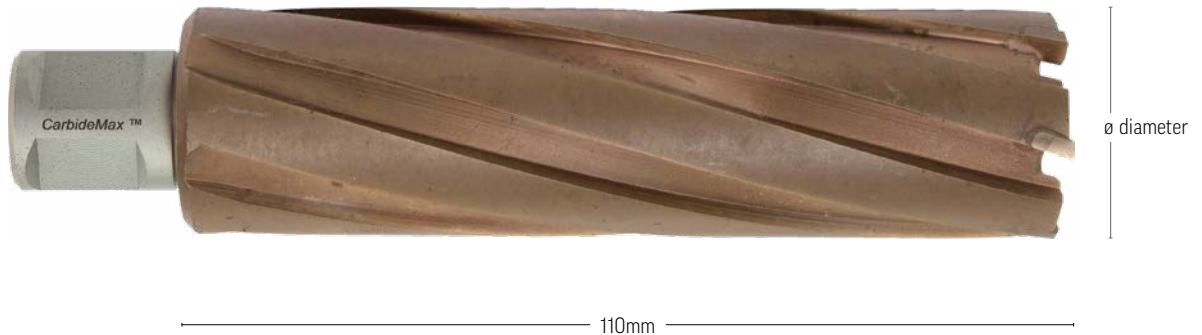
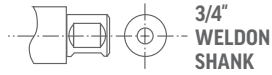

9x
LIFE

than uncoated
TCT tools

IDEAL FOR

- BISALLOY®
- HARDOX®
- RAEX®
- ABRO®
- STRENX®
- CREUSABRO®



LONG LIFE



MAG BASED
DRILL

CarbideMax® Ultra cutters are specifically designed for long-life performance in the toughest broaching jobs on the planet, including Hardox® steel.

The specialist Ultra coating is proven to significantly increase tool life, making Ultra products the perfect solution in situations requiring high-performance durability, prolonged use or machining extremely hard materials.

They are produced from premium-grade materials and coated using a range of state-of-the-art, high-temperature surface coatings.

- Ultra coated for optimum performance and lifespan
- Increased wear resistance in the hardest materials
- Elaborate tool geometry for faster, quieter cutting
- Chatter free performance when used correctly
- Highest quality carbide teeth
- Individually brazed cutting teeth
- Up to 55mm depth of cut
- Standard 19.05mm Weldon shank



HANDI PACK
Supplied in
haggable
plastic pack



Best Practice Advice

PG 58



Speeds & Feeds | PG 58



Click or Scan & See



Alpha
Liquid Gold
Cutting Fluid*



Click or Scan | Pack Sizes

*Alpha Liquid Gold Cutting Fluid is formulated for extreme cutting performance and is recommended for use when tapping, drilling or reaming into all metals

MultiSink® Combination Countersink Tools

ROTARY RATED

For countersinking bolt holes from 16 - 26mm diameter. Use MultiSink® with variable speed magnet drill. The speed must be reduced when countersinking.

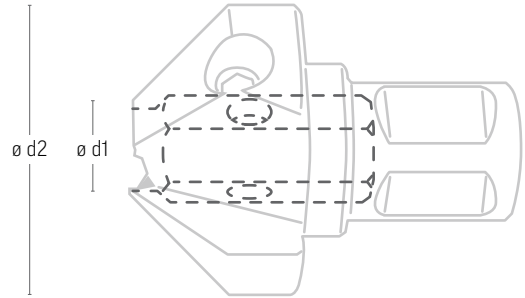
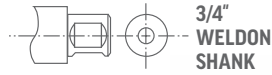

LONG LIFE



MAG BASED DRILL



2 x Pilot Pins
6.34mm x 145mm
14 - 17mm cutter size

Code: 101030P-0003



The MultiSink® is a worldwide unique new Combination Countersink Tool designed and developed for use with magnetic drills.

The tool is designed to combine with the VersaDrive product range to broach and countersink, drill and countersink, tap and countersink or even drill, tap and countersink in one operation - providing huge time-saving benefits.

The MultiSink® is available in HSS and Tungsten Carbide Tipped versions. The HSS MultiSink® features a Titanium nitride coating which reduces heat and increases lubricity for extended life whilst the TCT version is specifically designed for countersinking Inox and the hardest structural steels.

- Innovative combination countersinking tool
- Save time completing countersunk holes
- Broach and countersink in one operation
- Operations involving tapping require a magnet drill with variable speed and reverse features
- For predrilled holes, the MultiSink® should always be used with a pilot to avoid damage
- When used to drill or broach and countersink or for multiple operations eg drill/tap/countersink it is important to use the correct RPM for each separate operation
- Drill and countersink in one operation
- Tap and countersink in one operation
- Drill-Tap and countersink in one operation



Best Practice Advice

PG 58



Recommended Companions



Speeds & Feeds | **PG 58**



Click or Scan & See |



Alpha Liquid Gold Cutting Fluid*



Click or Scan | **Pack Sizes**

*Alpha Liquid Gold Cutting Fluid is formulated for extreme cutting performance and is recommended for use when tapping, drilling or reaming into all metals



CARBIDEMAX® ULTRA				HANDI PACK
ø mm d2	ø d1 mm	OAL mm	Point Angle	CODE 1 PCE
40.0	14	50	90°	601056-0400
55.0	14	65	90°	601056-0550

IDEAL FOR

BISALLOY®
HARDOX®
RAEX®
ABRO®
STRENX®
CREUSABRO®

● ● ● ● ●



CARBIDEMAX® TCT				HANDI PACK
ø d2mm	ø d1 mm	OAL mm	Point Angle	CODE 1 PCE
40.0	14	50	90°	601055-0400
55.0	14	65	90°	601055-0550

IDEAL FOR

	CAST IRON ● ● ● ● ●		PLASTIC ● ● ● ● ●
	STAINLESS STEEL ● ● ● ● ●		FIBREGLASS ● ● ● ● ○
	STEEL ● ● ● ● ●		COMPOSITE DECKING ● ● ● ● ○
	ALUMINIUM ● ● ● ● ●		WOOD ● ● ● ● ○

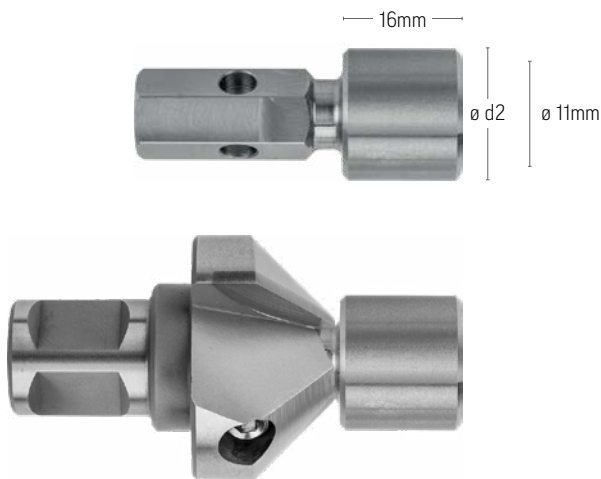

PILOT		HANDI PACK
ø d2 mm	OAL mm	CODE 1 PCE
14.0	45	601050-0140
16.0	45	601050-0160
18.0	45	601050-0180
20.0	45	601050-0200
22.0	45	601050-0220
24.0	45	601050-0240
26.0	45	601050-0260

For predrilled holes, the MultiSink® should always be used with a pilot to avoid damage.

Select the correct size pilot based on the hole size.

Securely locate and fasten shank inside the Multisink®.

Registered Trademarks: Bisalloy® is a registered trademark of Bisalloy Steels Pty Limited. Hardox® Wear Plate, Raex® Steel & Strenx® Performance Steel are registered trademarks of SSAB Technology AB.

ImpactaStep Cutters Guide



Product Range

PG 18

Ø	IMPACT TORQUE Nm		IMPACT TORQUE Ft Lbs		RPM (ROTATIONS PER MINUTE)					
	< 12mm Thick Steel	< 25mm Thick Steel	< 1/2" Thick Steel	< 1" Thick Steel	Structural Steel 500Nm	Structural Steel 1000Nm	Stainless Steel	Brass	Cast Iron	Aluminium
8 - 16mm	200 - 340	380 - 510	160 - 260	290 - 390	640 - 940	335 - 540	225 - 410	660 - 1020	340 - 550	920 - 1365
14 - 22mm	320 - 400	480 - 600	220 - 300	330 - 435	460 - 690	210 - 360	180 - 305	470 - 700	235 - 500	290 - 1100
18 - 26mm	360 - 545	540 - 840	270 - 405	410 - 640	310 - 535	140 - 290	135 - 210	375 - 550	200 - 305	400 - 800
24 - 32mm	520 - 680	780 - 1020	385 - 545	600 - 820	250 - 360	110 - 150	100 - 140	275 - 430	170 - 215	305 - 490
5/16 - 9/16"	200 - 340	380 - 510	160 - 260	290 - 390	640 - 940	335 - 540	225 - 410	660 - 1020	340 - 550	920 - 1365
9/16 - 13/16"	320 - 400	480 - 600	220 - 300	330 - 435	460 - 690	210 - 360	180 - 305	470 - 700	235 - 500	290 - 1100
13/16 - 1/16"	360 - 545	540 - 840	270 - 405	410 - 640	310 - 535	140 - 290	135 - 210	375 - 550	200 - 305	400 - 800

Best Practice Advice



Follow guidelines to set correct torque/RPM speed. Incorrect torque/RPM can lead to poor life or tool breakage.



Hardened or heat-affected materials may require higher torque, reduced RPM and feed rates and extra cutting fluid.



Apply firm, steady feed pressure throughout the cut.



When drilling into box section ensure the tip of the tool is not contacting the far side of the box section at the same time it is drilling the outside wall. This may cause breakage to the tool.



Avoid lateral movement or tilting which can cause damage to the tool.



When using with cordless power tools keep an eye on battery charge levels as torque consistency will diminish in a low battery.

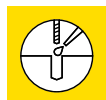

Ensure regular application of quality cutting fluid, especially when drilling thick or hardened materials.

Correct usage and setup are critical for good results. An incorrect and poorly maintained drill, wrench or driver with unstable operations, poor hold, excessive pressure or inadequate lubrication will likely result in early tool failure. This information is intended to provide general guidance and best practice advice to users of an appropriate skill level at their own discretion and risk. These recommendations are dependent on the user, material, application and circumstance of use. Alpha is not accountable for any user's actions. It's the user's responsibility to determine how much skill, technical experience, safety measures and operational knowledge is needed before using an Alpha VersaDrive product.

Impact Step Drills Guide



Product Range

PG 20

ø	IMPACT TORQUE		RPM (ROTATIONS PER MINUTE)					
	Nm	Ft Lb	Structural Steel 500Nm	Structural Steel 1000Nm	Stainless Steel	Aluminium	Cast Iron	Plastic
4 - 12mm	200 - 280	-	1200 - 3100	740 - 2000	380 - 1000	1200 - 3100	450 - 1300	650 - 1800
14 - 22mm	330 - 400	-	430 - 597	270 - 390	145 - 200	440 - 600	180 - 245	275 - 380
24 - 30mm	400 - 485	-	330 - 420	215 - 260	110 - 140	330 - 420	135 - 175	180 - 275
32 - 40mm	610 - 750	-	230 - 260	145 - 160	75 - 85	230 - 260	85 - 95	140 - 150
3/16 - 1/2"	-	270 - 380	1200 - 3100	740 - 2000	380 - 1000	1200 - 3100	450 - 1300	650 - 1800
3/16 - 7/8"	-	440 - 540	430 - 597	270 - 390	145 - 200	440 - 600	180 - 245	275 - 380
1/4 - 1 3/8"	-	540 - 660	330 - 420	215 - 260	110 - 140	330 - 420	135 - 175	180 - 275

Best Practice Advice



Step drills are not designed to drill a new hole, rather enlarge an existing one. Apply firm, steady feed pressure throughout the cut.



Follow guidelines to set correct torque/RPM speed. Incorrect torque/RPM can lead to poor life or tool breakage. When drilling stainless steel and harder materials, a lower RPM is recommended.



Avoid lateral movement or tilting which can cause damage to the tool.

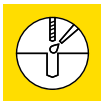

Ensure regular application of quality cutting fluid, especially when drilling thick or hardened materials.



Hardened or heat-affected materials may require higher torque, reduced RPM and feed rates and extra cutting fluid.



When drilling into box section ensure the tip of the Step-Drill is not contacting the far side of the box section at the same time it is drilling the outside wall. This may cause breakage to the tool.

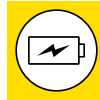

When using with cordless power tools keep an eye on battery charge levels as torque consistency will diminish in a low battery.

Impact Reamers Guide





Ø	IMPACT TORQUE Nm		IMPACT TORQUE Ft Lbs		RPM (ROTATIONS PER MINUTE)					
	< 12mm Thick Steel	< 25mm Thick Steel	< 1/2" Thick Steel	< 1" Thick Steel	Structural Steel 500Nm	Structural Steel 1000Nm	Stainless Steel	Brass	Cast Iron	Aluminium
8.0	200	380	160	290	940	540	410	1020	550	1365
10.0	220	400	175	300	900	510	380	1005	530	1290
12.0	280	420	185	305	875	490	370	995	520	1200
14.0	320	480	220	330	690	360	305	700	500	1100
16.0	340	510	260	390	640	335	225	660	340	920
18.0	360	540	270	410	535	290	210	550	305	800
20.0	380	570	285	425	490	230	195	510	250	745
21.0	390	580	290	430	480	225	190	500	240	710
22.0	400	600	300	435	460	210	180	470	235	690
24.0	520	780	385	600	310	140	135	375	200	400
26.0	545	840	405	640	310	140	135	375	200	400
1/2"	300	445	205	310	875	490	370	520	510	1185
9/16"	330	490	235	355	690	360	305	450	450	1025
5/8"	335	505	250	375	640	335	225	340	340	975
11/16"	350	525	265	400	535	290	210	305	305	860
3/4"	370	550	280	420	490	230	195	250	280	745
13/16"	390	580	290	430	480	225	190	500	240	710
7/8"	425	630	310	440	460	210	180	235	235	675
15/16"	460	695	380	575	360	150	140	215	215	540
1"	530	805	390	620	310	140	135	200	200	410
1 1/16"	596	894	440	660	295	130	125	185	190	385

Best Practice Advice

- 

Follow guidelines to set correct torque/RPM speed. Incorrect torque/RPM can lead to poor life or tool breakage.
- 

Ensure regular application of quality cutting fluid, especially when drilling thick or hardened materials.
- 

To maximise tool life do not attempt to increase the existing hole diameter beyond 2mm. If a larger, finished hole size is required, then the next size reamer should be used to 'step up' until the finished hole diameter is reached.
- 

Apply firm, steady feed pressure throughout the cut, applying the feed very slowly and cautiously during the first 1mm of cut.
- 

Flame cut, laser cut or punched holes may not be possible to ream with impact wrench. In this situation ream with a slow speed magnet drill.
- 

Never run a reamer in reverse, this will prematurely make the tool blunt.
- 

Avoid lateral movement or tilting which can cause damage to the tool.
- 

When using with cordless power tools keep an eye on battery charge levels as torque consistency will diminish in a low battery.

Correct usage and setup are critical for good results. An incorrect and poorly maintained drill, wrench or driver with unstable operations, poor hold, excessive pressure or inadequate lubrication will likely result in early tool failure. This information is intended to provide general guidance and best practice advice to users of an appropriate skill level at their own discretion and risk. These recommendations are dependent on the user, material, application and circumstance of use. Alpha is not accountable for any user's actions. It's the user's responsibility to determine how much skill, technical experience, safety measures and operational knowledge is needed before using an Alpha VersaDrive product.

TurboTip® Drill Bits Guide



Product Range

PG 14

Ø	IMPACT TORQUE Nm			IMPACT TORQUE Ft Lbs			RPM (ROTATIONS PER MINUTE)						
	< 6mm Thick Steel	< 12mm Thick Steel	< 25mm Thick Steel	< 1/4" Thick Steel	< 1/2" Thick Steel	< 1" Thick Steel	Structural Steel 500Nm	Structural Steel 1000Nm	Stainless Steel	Brass	Cast Iron	Plastic	Aluminium
6.0	140	170	280	104	126	207	2040	1070	710	1820	1045	1630	2850
6.8	155	189	291	114	139	214	1831	1049	643	1605	833	1450	2304
7.0	160	195	300	119	144	222	1780	1020	625	1560	810	1410	2240
8.0	220	270	380	163	200	281	1580	840	550	1340	725	1220	1765
8.5	278	339	490	205	250	361	1277	792	443	1193	633	1098	1636
9.0	295	360	520	219	267	385	1210	750	420	1130	600	1040	1550
10.0	320	395	580	237	293	430	1030	520	385	1020	550	990	1480
10.5	323	400	590	238	295	590	1000	510	365	990	510	960	1400
11.0	325	405	595	241	300	441	980	500	345	960	490	950	1365
12.0	350	430	635	259	319	470	860	440	310	825	405	860	1280
13.0	370	445	675	274	330	500	720	390	260	730	385	745	1160
14.0	375	455	690	278	337	511	660	350	225	665	340	620	950
16.0	455	580	880	337	430	652	535	290	200	610	310	510	875
18.0	580	720	1120	430	533	830	490	245	190	580	275	440	800
20.0	685	845	1245	507	626	922	450	220	175	550	240	350	730
22.0	720	900	1360	533	667	1007	340	180	160	510	210	330	645
3/16"	120	150	220	89	111	163	2270	1135	750	2215	1290	1910	3340
#7	125	155	240	93	115	178	2250	1100	745	2100	1220	1800	3100
7/32"	135	160	260	100	119	193	2125	1095	730	1980	1125	1710	3020
#F	154	185	298	114	137	220	1898	1015	663	1673	917	1503	2562
1/4"	150	180	290	111	133	215	1945	1040	680	1715	940	1540	2625
9/32"	175	220	320	130	163	237	1710	985	595	1410	785	1355	2110
5/16"	190	245	350	141	181	259	1695	915	570	1355	760	1290	1940
11/32"	260	330	470	193	244	348	1390	800	515	1435	660	1200	1660
3/8"	300	375	545	222	278	404	1140	665	400	1095	590	1020	1510
27/64"	330	410	610	244	304	452	925	480	330	890	465	915	1320
7/16"	340	420	625	252	311	463	895	455	320	845	430	890	1305
1/2"	365	440	650	270	326	481	780	410	375	780	400	805	1210

Best Practice Advice



Follow guidelines to set correct torque/RPM speed. Incorrect torque/RPM can lead to poor life or tool breakage.



Ensure regular application of quality cutting fluid, especially when drilling thick or hardened materials.



VersaDrive TurboTips can be used without piloting at all sizes.



Apply firm, steady feed pressure throughout the cut.



Hardened or heat-affected materials may require higher torque, reduced RPM and feed rates and extra cutting fluid.

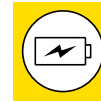

When using with cordless power tools keep an eye on battery charge levels as torque consistency will diminish in a low battery.

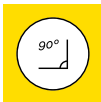

Avoid lateral movement or tilting which can cause damage to the tool.

Cobalt Drill Bits Guide



Product Range

PG 16

Ø	IMPACT TORQUE Nm	RPM (ROTATIONS PER MINUTE)					
		Structural Steel 500Nm	Structural Steel 1000Nm	Stainless Steel	Special Alloys Duplex Hardox® Bisalloy®	Cast Iron	Aluminium Brass Plastic
4.2	120	2264	1360	1210	680	2264	5220
5.0	130	2220	1140	1010	570	2220	4390
5.5	135	2020	1040	920	520	2020	3990
6.0	140	1850	950	840	470	1850	3660
6.5	160	1700	880	680	440	1700	3370
6.8	170	1630	840	740	420	1630	3230
7.0	195	1580	810	725	400	1580	3130
7.5	220	1480	760	670	380	1480	2920
8.0	240	1390	710	630	350	1390	2740
8.5	270	1310	670	590	330	1310	2580
9.0	360	1230	630	560	310	1230	2440
9.5	370	1170	600	530	300	1170	2310
10.0	375	1110	570	500	280	1110	2190
10.2	380	1190	560	490	275	1190	2150
10.5	405	1160	545	480	270	1160	2090
11.0	410	1010	520	460	260	1010	1990
11.5	415	960	495	440	245	960	1900
12.0	420	920	470	420	235	920	1830
12.5	430	890	450	400	225	890	1750
13.0	435	810	440	390	220	810	1680
14.0	440	790	405	360	200	790	1560
16.0	N/A	690	350	310	175	690	1370
17.5	N/A	630	320	280	160	630	1250
18.0	N/A	610	310	270	155	610	1120
20.0	N/A	550	280	250	140	550	1090
21.0	N/A	530	270	240	135	530	1040
22.0	N/A	500	260	220	130	500	990

Best Practice Advice



Follow guidelines to set correct torque/RPM speed. Incorrect torque/RPM can lead to poor life or tool breakage.



Avoid lateral movement or tilting which can cause damage to the tool.



Hardened or heat-affected materials may require higher torque, reduced RPM and feed rates and extra cutting fluid.



Apply firm, steady feed pressure throughout the cut.



Ensure regular application of quality cutting fluid, especially when drilling thick or hardened materials.



When using with cordless power tools keep an eye on battery charge levels as torque consistency will diminish in a low battery.

Registered Trademarks: Bisalloy® is a registered trademark of Bisalloy Steels Pty Limited. Hardox® Wear Plate, Raex® Steel & Strenx® Performance Steel are registered trademarks of SSAB Technology AB. Creusabro® is a registered trademark of Industeel France. Abro® is a registered trademark of ABRO Industries, Inc.

Correct usage and setup are critical for good results. An incorrect and poorly maintained drill, wrench or driver with unstable operations, poor hold, excessive pressure or inadequate lubrication will likely result in early tool failure. This information is intended to provide general guidance and best practice advice to users of an appropriate skill level at their own discretion and risk. These recommendations are dependent on the user, material, application and circumstance of use. Alpha is not accountable for any user's actions. It's the user's responsibility to determine how much skill, technical experience, safety measures and operational knowledge is needed before using an Alpha VersaDrive product.

ImpactaTaps® Guide



Ø	IMPACT TORQUE Nm			IMPACT TORQUE Ft Lbs			RPM (ROTATIONS PER MINUTE)				
	< 6mm Thick Steel	< 12mm Thick Steel	< 25mm Thick Steel	< 1/4" Thick Steel	< 1/2" Thick Steel	< 1" Thick Steel	Structural Steel 500Nm	Structural Steel 1000Nm	Stainless Steel	Aluminium	Cast Iron
M3	105	160	N/A	80	120	N/A	960	809	650	2700	1295
M4	120	180	N/A	90	135	N/A	730	610	490	2060	975
M5	135	200	N/A	100	150	N/A	585	485	385	1750	780
M6	140	240	400	105	180	N/A	485	405	325	1455	650
M8	150	280	430	115	210	330	365	310	245	1095	485
M10	170	300	480	125	220	360	295	245	195	870	390
M12	185	320	512	135	235	400	240	200	162	730	330
M14	190	340	544	140	250	400	210	175	140	625	275
M16	200	360	576	150	265	425	185	155	125	550	243
M20	315	400	640	235	300	470	145	125	100	440	194
M24	N/A	600	960	N/A	440	720	120	100	85	370	165
M27	N/A	740	1184	N/A	545	875	105	90	75	330	145
M30	N/A	800	1200	N/A	590	885	95	80	60	310	130
1/4"	145	255	410	105	180	295	485	405	325	1455	650
5/16"	145	265	420	110	205	320	365	310	245	1095	485
3/8"	165	290	440	125	220	355	295	245	195	870	390
1/2"	190	330	525	135	235	375	240	200	162	730	330
5/8"	195	355	555	145	365	425	185	155	125	550	243
3/4"	245	385	615	230	295	470	145	125	100	440	194
7/8"	N/A	515	775	N/A	370	710	130	115	92	410	180
1"	N/A	695	1050	N/A	445	735	120	100	85	370	165

Best Practice Advice

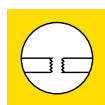

ImpactaTaps® are recommended for through hole applications only. Spiral flute taps are designed for blind hole applications.



Pilot drill the exact tapping size hole for best results.



Apply firm, steady feed pressure throughout the cut.

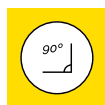

Ensure the tap is inserted squarely to the hole - poorly aligned or off-centre taps will greatly increase the risk of breakage.



Select the correct torque power for impact wrench/drivers using the data range above. If exact match is not available select the closest torque setting above the recommendation.



Regularly apply quality cutting fluid, especially when drilling thick or hardened materials.



Hardened or heat-affected materials may require higher torque, reduced RPM and feed rates and extra cutting fluid.



Flame cut/punched holes will require more torque to tap than drilled holes due to heat build up. Caution: Sometimes flame cut holes do not have parallel sides meaning risk of tap breakage. This application may also reduce tool life.

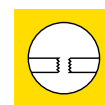

Tap the hole in one pass where possible, applying adequate lubrication before you start. For thicker materials above 25mm multiple passes may be required (to clean out swarf and re lubricate tap).

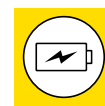

When using with cordless power tools keep an eye on battery charge levels as torque consistency will diminish in a low battery.



If the tap is over-run from the hole once it is tapped, to remove the risk of cross-threading/damage to the tap, remove the tap from the adapter and locate it in the thread by hand, before reversing.

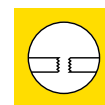

When re-threading an existing thread, use caution to avoid cross-threading which can lead to tap breakage or thread damage. It is advisable to insert/start the tap into the thread by hand before driving it through at the correct torque





Combi Drill Taps & Heavy Duty ImpactaTaps® Drill Taps Guide



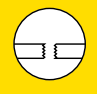

Ø	IMPACT TORQUE Nm			IMPACT TORQUE Ft Lbs			RPM (ROTATIONS PER MINUTE)				
	< 6mm Thick Steel	< 12mm Thick Steel	< 25mm Thick Steel	< 1/4" Thick Steel	< 1/2" Thick Steel	< 1" Thick Steel	Structural Steel 500Nm	Structural Steel 1000Nm	Stainless Steel	Aluminium	Cast Iron
M3	105	160	N/A	75	120	N/A	960	809	650	2700	1295
M4	120	180	N/A	90	130	N/A	730	610	490	2060	975
M5	135	200	N/A	95	145	N/A	585	485	385	1750	780
M6	140	240	N/A	100	180	N/A	485	405	325	1455	650
M8	150	280	N/A	110	205	N/A	365	310	245	1095	485
M10	170	300	N/A	170	300	N/A	295	245	195	870	390
M12	185	320	512	135	235	380	240	200	162	730	330
M14	195	340	544	140	300	405	210	175	140	625	275
M16	200	360	576	150	265	425	185	155	125	550	243
M20	315	400	640	230	295	475	145	125	100	440	194
M24	N/A	600	960	N/A	420	720	120	100	85	370	165
1/4"	145	255	N/A	105	175	295	485	405	325	1455	650
5/16"	145	265	N/A	105	205	330	365	310	245	1095	485
3/8"	160	290	N/A	115	220	355	295	245	195	870	390
1/2"	190	330	520	140	235	375	240	200	162	730	330
5/8"	195	355	555	145	365	425	185	155	125	550	243
3/4"	245	380	610	185	295	470	145	125	100	440	194
7/8"	N/A	515	715	N/A	370	710	130	115	92	410	180
1"	N/A	675	1050	N/A	445	735	120	100	85	370	165

Best Practice Advice

- 

Impact Drill Taps are recommended for through hole applications only. Follow guidelines to set correct torque/RPM speed. Incorrect torque/RPM can lead to poor life or tool breakage.
- 

When tapping material thicker than 15-20mm, to speed up the process it is advisable to pilot drill the hole first, before drill-tapping the hole.
- 

Tap the hole in one pass where possible, applying adequate lubrication before you start.
- 

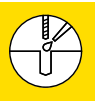
Pilot drill the exact tapping size hole for best results (HD variant when used with an impact wrench).
- 

Ensure regular application of quality cutting fluid, especially when drilling thick or hardened materials.
- 

301125- Sheet Metal Drill-Taps are intended for tapping material no greater than the tap diameter when driven with an impact wrench.
- 

Select correct Nm torque power for impact wrench applications.
- 

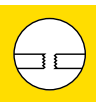
Hardened or heat-affected materials may require higher torque, reduced RPM and feed rates and extra cutting fluid.
- 

301130- Heavy Duty Drill Taps are designed for use with magnet drills/ Pillar Drills, or for tapping pre-drilled holes with an impact wrench. They are not designed for drill-tapping with hand-held rotary tools.
- 

Apply firm, steady feed pressure throughout the cut.
- 

Flame cut/punched holes will require more torque to tap than drilled holes due to heat build up. Caution: Sometimes flame cut holes do not have parallel sides meaning risk of tap breakage. This application may also reduce tool life.
- 

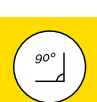
When using with cordless power tools keep an eye on battery charge levels as torque consistency will diminish in a low battery.
- 

Ensure the tap is inserted squarely to the hole - misaligned taps will greatly increase the risk of breakage.

Correct usage and setup are critical for good results. An incorrect and poorly maintained drill, wrench or driver with unstable operations, poor hold, excessive pressure or inadequate lubrication will likely result in early tool failure. This information is intended to provide general guidance and best practice advice to users of an appropriate skill level at their own discretion and risk. These recommendations are dependent on the user, material, application and circumstance of use. Alpha is not accountable for any user's actions. It's the user's responsibility to determine how much skill, technical experience, safety measures and operational knowledge is needed before using an Alpha VersaDrive product.

Combination Drillsinks Guide



ø	COUNTERSINK RPM (ROTATIONS PER MINUTE)					
	Structural Steel 500Nm	Structural Steel 1000Nm	Stainless Steel	Aluminium	Cast Iron	Plastic
12.4	385	255	110	635	265	480
16.5	295	185	80	485	210	345
20.5	230	155	50	385	165	280
25.0	185	130	50	315	130	225
31.0	155	105	35	265	105	185

ø	DRILLING RPM (ROTATIONS PER MINUTE)					
	Structural Steel 500Nm	Structural Steel 1000Nm	Stainless Steel	Aluminium	Cast Iron	Plastic
6.8	1630	840	740	3230	1630	3230
8.0	1390	710	630	2740	1390	2740
8.5	1310	670	590	2580	1310	2580
10.0	1110	570	500	2190	1110	2190
10.2	1190	560	490	2150	1190	2150
11.0	1010	520	460	1990	1010	1990
12.0	920	470	420	1830	920	1830
13.0	810	440	390	1680	195	1680
14.0	790	405	360	1560	790	1560

Best Practice Advice



The Drillsink should be used with a variable speed motor, and the drill and countersink operations should be run at the appropriate speed for each process.

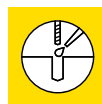

Ensure regular application of quality cutting fluid, especially when drilling thick or hardened materials.



Best countersinking results are achieved using a variable speed drill that allows the correct speed to be set, allowing high torque and low gear speed. (reduce RPM further for difficult applications).



Apply firm, steady feed pressure throughout the cut.



Hardened or heat-affected materials may require higher torque, reduced RPM and feed rates and extra cutting fluid.



Follow guidelines to set correct RPM speed. Incorrect RPM can lead to poor life or tool breakage.



Avoid lateral movement or tilting which can cause damage to the tool.



Flame/Lazer cut/punched holes will require more torque to Countersink than drilled holes due to heat build up. Caution: Sometimes flame cut holes do not have parallel sides meaning risk of wear breakage. This application may also reduce tool life.



When using with cordless power tools keep an eye on battery charge levels as torque consistency will diminish in a low battery.



Piloted Countersink Bits (like the MultiSink® see pg 46) will significantly increase countersinking performance preventing movement of the countersink whilst drilling.

3 Flute Countersinks 90° Guide



Product Range

PG 36

ø	RPM (ROTATIONS PER MINUTE)					
	Structural Steel 500Nm	Structural Steel 1000Nm	Stainless Steel	Cast Iron	Plastic	Aluminium
6.3	765	505	265	1250	500	850
10.4	460	300	145	765	315	530
12.4	385	255	110	635	265	480
16.5	295	185	80	485	210	345
20.5	230	155	50	385	165	280
25.0	185	130	50	315	130	225
30.0	155	105	35	265	105	185
40.0	120	80	30	205	80	140
55.0	95	60	25	145	70	120
63.0	80	55	20	130	55	90
80.0	65	40	20	100	45	75

Best Practice Advice



Follow guidelines to set correct RPM speed. Incorrect RPM can lead to poor life or tool breakage. For CarbideMax MultiSink® (601056) recommended range of 25-60 RPM is necessary for good results in Hardox/Bisalloy.

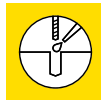

Ensure regular application of quality cutting fluid, especially when drilling thick or hardened materials.



Flame/Lazer cut/punched holes will require more torque to Countersink than drilled holes due to heat build up. Caution: Sometimes flame cut holes do not have parallel sides meaning risk of wear breakage. This application may also reduce tool life.



Apply firm, steady feed pressure throughout the cut.



Hardened or heat-affected materials may require higher torque, reduced RPM and feed rates and extra cutting fluid.



Piloted Countersink Bits (like the MultiSink® see pg 46) will significantly increase countersinking performance preventing movement of the countersink whilst drilling.

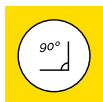

Avoid lateral movement or tilting which can cause damage to the tool.



Best countersinking results are achieved using a variable speed drill that allows the correct speed to be set. Use at correct RPM (if unsure use tachometer to check drill speed).

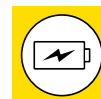

When using with cordless power tools keep an eye on battery charge levels as torque consistency will diminish in a low battery.

Correct usage and setup are critical for good results. An incorrect and poorly maintained drill, wrench or driver with unstable operations, poor hold, excessive pressure or inadequate lubrication will likely result in early tool failure. This information is intended to provide general guidance and best practice advice to users of an appropriate skill level at their own discretion and risk. These recommendations are dependent on the user, material, application and circumstance of use. Alpha is not accountable for any user's actions. It's the user's responsibility to determine how much skill, technical experience, safety measures and operational knowledge is needed before using an Alpha VersaDrive product.

TCT Hole Cutters Guide



Product Range

PG 38

Ø	RPM (ROTATIONS PER MINUTE)								
	Structural Steel 500Nm	Structural Steel 1000Nm	Stainless Steel	Aluminium	Cast Iron	Fibreglass	Composite Decking	Plastic	Wood
13 - 17	850 - 1350	585 - 840	360 - 500	1575 - 2210	625 - 900	705 - 780	850 - 1350	640 - 900	1010 - 1495
18 - 25	625 - 850	420 - 580	250 - 350	1125 - 1575	455 - 600	520 - 700	625 - 850	450 - 620	895 - 990
26 - 31	500 - 620	325 - 415	195 - 240	885 - 1080	345 - 435	405 - 500	500 - 620	345 - 440	850 - 895
32 - 39	410 - 480	275 - 320	160 - 195	740 - 875	285 - 330	330 - 400	410 - 480	280 - 345	740 - 850
40 - 46	340 - 390	220 - 270	145 - 160	620 - 730	240 - 285	275 - 315	340 - 390	175 - 235	610 - 740
47 - 53	300 - 335	180 - 220	120 - 140	545 - 615	215 - 235	245 - 275	300 - 335	215 - 235	505 - 600
54 - 60	260 - 295	165 - 180	100 - 115	485 - 525	180 - 210	215 - 240	260 - 295	185 - 210	460 - 500
61 - 70	225 - 260	155 - 165	90 - 100	415 - 475	160 - 180	185 - 205	225 - 260	160 - 180	400 - 455
71 - 80	195 - 220	140 - 155	75 - 90	365 - 410	140 - 155	160 - 180	195 - 220	140 - 155	360 - 395

Best Practice Advice

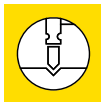

Centre punch or pilot drill the surface for accurate hole start.



Ensure regular application of quality cutting fluid, especially when drilling thick or hardened materials.



For drilling holes in steel thicker than 25mm it is recommended to ventilate the hole frequently to clear the swarf.



Follow guidelines to set correct RPM speed. Incorrect RPM can lead to poor life or tool breakage.



Hardened or heat-affected materials may require higher torque, reduced RPM and feed rates and extra cutting fluid.



For thicker materials, predrill 6.35mm pilot hole first and use then sprung pilot drill or pilot pin as a guide.



Apply firm, steady feed pressure throughout the cut, applying the feed very slowly and cautiously during the first 1mm of cut.



When using a magnet drill regularly check that the slides, handles, arbors and movable parts have not vibrated loose over time.



When using with cordless power tools keep an eye on battery charge levels as torque consistency will diminish in a low battery.

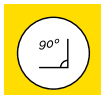

Avoid lateral movement or tilting which can cause damage to the tool.

CarbideMax® Ultra Broach Cutters & MultiSink® Guide



MULTISINK® RPM	
ø mm	Hardox® 400 / 500
40.0	30 - 60
55.0	25 - 60

BROACH CUTTER RPM (NO LOAD)	
ø mm	Hardox® 400 / 500 (Based on 18.0 m/min)
16.0	358
18.0	318
20.0	286
22.0	250
24.0	239
26.0	220

BROACH CUTTER RPM (NO LOAD)	
ø mm	Hardox® 400 / 500 (Based on 18.0 m/min)
28.0	205
30.0	191
32.0	179
34.0	169
36.0	159

Best Practice Advice



Cautious & gentle feed pressure should be used at all times, especially during the start of the cut and exiting the material.



For best results, use a powerful magnet drill with high torque and low gear speed.



Swarf removal from the cutter can assist with longer tool life.

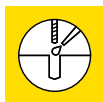

Backing off the cutter & applying more cutting fluid is necessary for increasing tool life.

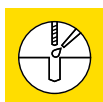

Generous application of cutting fluid should be used during the cut & applied frequently during the cut with thorough cutter cutting fluid supply if possible.

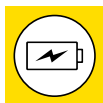

When using with cordless power tools keep an eye on battery charge levels as torque consistency will diminish in a low battery.

MACHINING OF WEAR PLATES

HARDOX®

BISALLOY®

RAEX®

STRENX®

ABRO®

CREUSABRO®

The extreme hardness and resistance of wear plate makes machining it extremely challenging. Good results are dependent on the right setup - including high torque/ slow speed, geared magnet drills and ample lubrication when broaching countersinking.

Using an incorrect or poorly maintained magnet drill with unstable drilling operation, poor magnet hold, excessive pressure or inadequate lubrication is likely to result in rapid tool failure.

Even with high tech tooling, successfully machining wear plates is challenging with little or no margin for error. It not only requires the correct setup but also experienced operators with the time necessary to proceed with caution.

Application information

Drilling holes in very hard materials is a specialist task and good results are dependent on the correct set-up, including:

- Slow RPM speed
- Consistent feed
- Hi rigidity/clamping force
- Geared mag-based drills with high torque
- Abundant and high quality lubricant

Inadequate lubrication and/or using an incorrect or a poorly maintained mag-based drill with unstable drilling operation, poor magnet hold or excessive pressure is likely to result in tool failure.

Registered Trademarks: Bisalloy® is a registered trademark of Bisalloy Steels Pty Limited. Hardox® Wear Plate, Raex® Steel & Strenx® Performance Steel are registered trademarks of SSAB Technology AB. Creusabro® is a registered trademark of Industeel France. Abro® is a registered trademark of ABRO Industries, Inc.

Correct usage and setup are critical for good results. An incorrect and poorly maintained drill, wrench or driver with unstable operations, poor hold, excessive pressure or inadequate lubrication will likely result in early tool failure. This information is intended to provide general guidance and best practice advice to users of an appropriate skill level at their own discretion and risk. These recommendations are dependent on the user, material, application and circumstance of use. Alpha is not accountable for any user's actions. It's the user's responsibility to determine how much skill, technical experience, safety measures and operational knowledge is needed before using an Alpha VersaDrive product.



**NEW
POCKET
MANUAL**

**SPEED?
RPM?
TORQUE?
MATERIAL?
TOOL?**

**ON-HAND
NO DOUBT**

**FEEDBACK
ENQUIRIES**
0800 65 69 11

Alpha

LESS
DOING...
**MORE
DONE!**



POWERED BY  **Sheffield**
GROUP

T 0800 65 69 11

alphatools.com.au

E sales@sheffieldgroup.co.nz

sheffieldgroup.co.nz



@alphatoolsaus
@sheffieldgroup