

08/24

ISSUE 8

JOIN THE GAP WEEK
A WEEK TO IMPACT YOUR LIFE
26-29 SEP

Career week in a holiday week

DIVE THE PHILLIPINES
THE ULTIMATE HOLIDAY SPOT
26 DEC - 5 JAN

Time to travel is all the time

INSERTS & ORINGS

Cowboy Social

Join us for a day of being a cowboy and cowgirl

scubaversity
the place you'd rather be

TABLE OF CONTENTS



3	<u>THE COWBOY SOCIAL</u> Don't miss this ol' rootin'-tootin' shindig!
4	<u>MASTER SCUBA DIVER</u> Join us and make memories with one of the best dive spots
5-6	<u>PHILIPPINES</u> Come join us on this incredible journey and experience the wonders and beauty of the Philippines!
7	<u>MARICO OOG</u> The best fresh water diving you could hope for.
8	<u>SOMETHING NEW</u> The Galileo Luna 2.0 and Galileo Luna 2.0 AI
9	<u>SODWANA</u> Breathtaking reefs for breathtaking people.
10	<u>THE SUN FISH</u> Natures beauty.
11	<u>MOZAMBIQUE</u> White beaches, blue skies, and good vibes, don't miss this one!
12	<u>EQUIP AND SIGN THE PETTITON</u> Learn more about our equipment evening, the plastic treaty and how you can make a difference.
13	<u>ALIWAL</u> Home to the kingdom of sharks and wrecks.
14	<u>COMBO DEALS</u> Don't miss out on these incredible deals.
15	<u>SEARCH PATTERNS</u> Learn more about the different search patterns and our search and recovery course.
16	<u>DIVE MASTER</u> Take your scuba diving to the next level.
17-18	<u>GAP WEEK</u> Learn more about our gap week, it's costs and what it includes.
19	<u>BREATHING SYSTEMS</u> The difference between an open, semi-closed, and closed circuit.
20-21	<u>SOMETHING FUN</u> Learn about air endurance and how to calculate SAC rates as well as your ears while diving.
22-24	<u>COURSES</u> Learn more about our rescue, nitrox online course, and courses of the month.
25-26	<u>ROB ALLEN AND MEMBER OF THE MONTH</u> See what a Rob Allen wetsuit is and our new club member of the month
27-28	<u>EQUIPMENT PROBLEMS, CLUB ALBUMS</u> Learn some solutions to common equipment problems and see our club albums.
29-30	<u>INTERNSHIP AND SOCIAL MEDIA</u> Learn more about our Blue Ocean internship and join our social media.

JOIN OUR COWBOY SOCIAL SAT | 3 Aug | 6PM

WANTED

ALIVE AND READY TO PARTY

Get ready for some gun-slinging high noon cowboy fun on the 3rd of August because the Scubaversity team is back at it again with another fun filled social in our own wild wild west setting! So saddle up and join us for a rip-roarin' Wild West hoedown! Dust off your cowboy boots, gather your posse, and mosey on over to the Scubaversity Saloon for a rootin' tootin' good time. Let's make this ol shindig one for the history books!

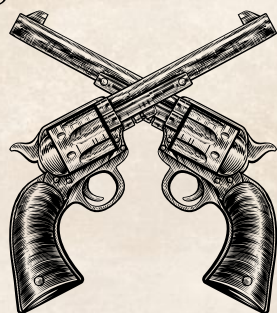

[CONTACT US!](#)

by Ethan Kiagias

Become a

Master Scuba Diver

Elite Status: Elevate your recreational diver status and join the world's elite 2% of divers with your PADI Master Scuba Diver rating.

Diverse Experience: Demonstrate your diving knowledge and depth of experience with the PADI Master Scuba Diver rating. From advanced dives to dive specialties, you've mastered it all.

Unparalleled Achievement: Reach the pinnacle of recreational diving with the PADI Master Scuba Diver rating.

Unlimited Opportunity: Explore a world of possibilities and dive into next-level adventure with your PADI Master Scuba Diver rating. Go deeper into dive specialties, access professional-level courses, and seek leadership roles within the dive community.

MSD Challenge: Maximize your dive potential and expand your horizons with the PADI Master Scuba Diver Challenge. Hone your dive skills, experience new adventures, and become the best of the best in recreational diving.

**APPLY FOR YOUR
MASTER SCUBA DIVER
RATING BEFORE END OF
2024 AND SAVE £55**

Prerequisites

- PADI Open Water Diver (or qualifying certification from another training organization)
- PADI Advanced Open Water Diver (or qualifying certification from another training organization)
- PADI Rescue Diver or Junior Rescue Diver (or qualifying certification from another training organization)
- Minimum of five PADI Specialty Diver courses
- Minimum of 50 logged dives
- £55.20 for PADI application form



Become a Master Scuba Diver

[CONTACT US!](#)

New Years Trip!

PHILIPPINES

26 DEC - 5 JAN

8 Nights 10 Dives

R25 750

White sandy beaches and the crystal clear warm water make this destination a divers paradise. Vast coral reefs and beautiful flora and fauna make the Philippines a true scuba diver's paradise. Including Scorpionfish, emperor fish, barracuda, Moorish idol, flutemouth, tuna, batfish, trevally, pygmy sea horses, parrotfish, lionfish, triggerfish, unicorn fish, trumpet fish, wrasse, mantis shrimp, squid, octopus, eagle rays, devil rays, manta rays and sharks.

MOALBOAL: MARCOSAS RESORT- 3 STAR LODGE IN CEBU

- 4 Night's accommodation in the Hideaway Room
- Tanks and weights
- Breakfast
- Marine Fees
- Scheduled transfers
- Wi-Fi

MALAPASCUA: EVOLUTION BEACH AND DIVE RESORT

- 4 Nights' accommodation in a Deluxe Air-Conditioned room
- 3 Dives including Monad Shoal
- 2 Dive Daytrip to Kalanggaman or Capitancillo Island including lunch, tanks and weights
- Breakfast daily
- Coffee & Tea
- Marine Fees
- Scheduled transfers

[CONTACT US!](#)





**JUST SOME REASONS
WHY YOU SHOULD
VISIT THE
PHILIPPINES!
ISLAND VIBE
WATERFALLS
ADVENTURE
NATURE
THRESHER SHARKS
WHALESHARKS
MACRO HEAVEN
BUDGET FRIENDLY**



Map of the Philippines showing 19 numbered locations for diving sites:

- 1. White Beach
- 2. Malibu Beach
- 3. Airplane wreck
- 4. ...
- 5. ...
- 6. ...
- 7. Tubia
- 8. ...
- 9. ...
- 10. ...
- 11. ...
- 12. Sempaguita
- 13. ...
- 14. ...
- 15. ...
- 16. Balabagon
- 17. ...
- 18. ...
- 19. Sunken Is.



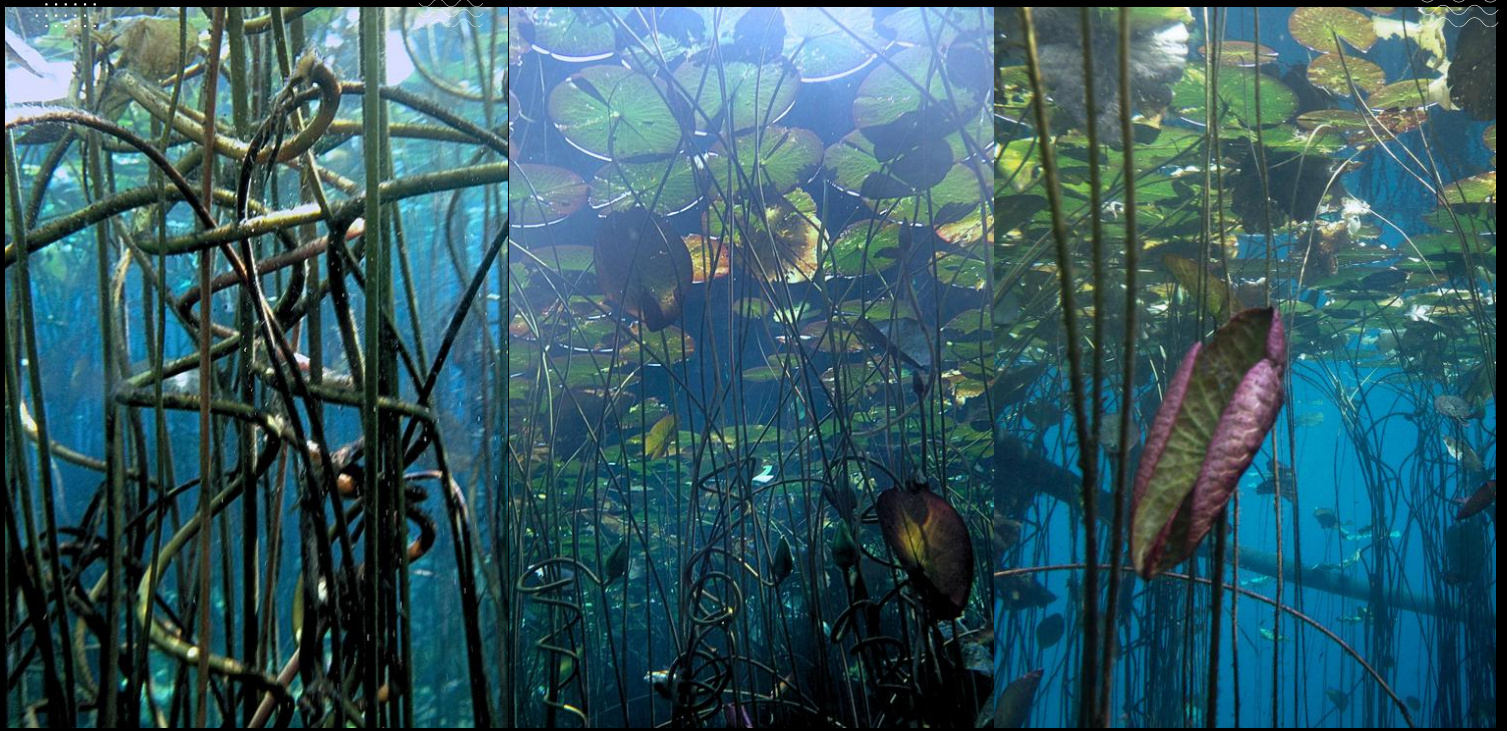

MARICO OOG

23-25 AUG

[CONTACT US!](#)

2 Nights 4 Dives **R1899**

Marico is renowned for its excellent visibility and lush underwater vegetation and is currently rated as the most scenic of all inland dive sights. The facilities are basic so bring out the usual camping equipment, chairs, tents, lamps etc. We'll supply the Breakfast and the infamous Potjie on Saturday night. All you'll need is your own snacks, drinks & alcohol.

Courses	Club Member	Non Member
Night Specialty	R3920	R4070
Peak Performance Specialty	R3920	R4070
Trip Cost: Includes, entrance, overnight fee, catering, airfills and gear.		
Casual Diver	R1899	R1999
Non Diver	R1499	R1599

JOIN THE CLUB!

MEMBERSHIP BENEFITS:

TRIPS

- Discounts on all trips.
- Free hard gear rental on all trips you do with Scubaversity.

POOL

- Free usage of our pool.
- Free usage of rental equipment when diving at our facility, only pay for your air fill

COURSES

- Discount on all courses
- Discount on all gear

PRIVATE RENTAL

- Discount on private gear rental , only pay for the days you are diving.
- Free printed Scubaversity calendar
- Invite to awesome socials!

AIR FILLS

- Discount on all airfills
- Free first air fill with cylinder hire if you join one of our monthly inland trips.

VIBE WITH YOUR TRIBE

R750 annually



GALILEO LUNA 2.0



GALILEO LUNA 2.0

GALILEO LUNA 2.0 AIR INTEGRATED GALILEO LUNA
2.0 AI WITH SMART+ PRO TRANSMITTER GALILEO

The NEW SCUBAPRO Luna 2.0 is a sleek, intuitive all-purpose dive computer loaded with easy-to-use features. Designed to be one of the thinnest dive computers, the Luna 2.0 offers an oil-filled thermoplastic housing for reliable performance and comfort. Its large modern widescreen features a high contrast black/white LCD display and large characters for easy reading at depth. A simple two-button interface lets you navigate the system with ease, aided by clearly marked screen prompts. You get a choice of ADT and GF algorithms, plus 100% nitrox compatibility and three selectable gasses for open circuit diving. Three dive modes are available – Scuba, Apnea and Gauge, along with selectable PDIS and six Microbubble levels.

- ◊ Easy-to-use design.
- ◊ Oil-filled thermoplastic housing is super thin and sits comfortably on the arm.
- ◊ Wide, high-contrast black and white LCD display screen and large characters for easy reading at depth.
- ◊ Intuitive menu and two button controls make it easy to navigate through the system.
- ◊ Choice of 2 algorithms: Predictive Multi-Gas Bühlmann ZH-L16 ADT MB PMG, or ZH-L16 + GF (Gradient Factor).
- ◊ Nitrox compatible (100%) with 3 selectable gasses.
- ◊ PDIS (Profile Dependent Intermediate Stops) calculates an intermediate stop based on N2 loading, current and previous dives, and breathing mixes for safer diving.
- ◊ Six Microbubble levels (L0-L5) let you personalise and adjust the level of conservatism in the ADT algorithm to match your experience level, age and physical conditioning.
- ◊ 3 Dive modes: Scuba, Gauge, and Apnea.
- ◊ NEW soft silicone arm strap is comfortable against your wrist.
- ◊ Durable silicone housing case cover & pre-installed screen protector
- ◊ Max Operating Depth: 394ft/120m.
- ◊ Bluetooth Low Energy interface lets you download dives to any iOS or Android device or PC/Mac.
- ◊ Firmware can be user-updated by going to scubapro.eu or the SCUBAPRO LogTRAK 2.0 app.
- ◊ CR2450 battery is user-changeable and rated for up to two years/300 dives.
- ◊ Bungee mounts on the corners of the housing allow for alternate securing methods.

GALILEO LUNA 2.0 AI



NOW!

R10 995

R 8 695

R12 495

R9 995

R19 995

R15 995

The NEW SCUBAPRO Luna 2.0 AI is a sleek, intuitive air-integrated dive computer loaded with easy-to-use features. Its wireless air integration feature enables you to monitor tank pressure easily, plus provides true remaining bottom time (RBT) and allows your air consumption to be factored into the decompression calculation. Designed to be one of the thinnest dive computers, the Luna 2.0 AI offers an oil-filled plastic housing for reliable performance and comfort. Its large modern widescreen features a high contrast black/white LCD display and large characters for easy reading at depth. A simple two-button interface lets you navigate the system with ease, aided by clearly marked screen prompts. You get a choice of ADT and GF algorithms, plus 100% nitrox compatibility and three selectable gasses for open circuit diving. Three dive modes are available – Scuba, Apnea and Gauge, along with selectable PDIS and six Microbubble levels. The Luna 2.0 AI also offers an optional integrated heart rate monitor that lets you visually track your heart rate and skin temperature to ensure you stay in your individual target zone to maximise fun and safety at depth.

- ◊ Air-integration monitors tank pressure and provides true remaining bottom time. (RBT) calculations based on the workload from breathing.
- ◊ Optional heart rate monitor (05.060.020) records heartbeat and skin temperature that can be factored into the decompression calculation along with workload.

logtrak[®]
SCUBAPRO



CONTACT US!

The annual birthday Trip!



SODWANA

20-24 SEP

4 Nights 3 Dives **R3999**

Includes tented accommodation, dives, breakfast & supper!
Excludes Parks Board Fees +/- R550

Sodwana is legendary, sunshine, warm 28-30° flat seas awesome visibility, and expect the occasional Manta.... Those who have been there know and have done it more than once, and keep coming back. Situated within the reserve it is geared towards an easy diving holiday. The food is good, accommodation is great and best of all there is a range to fit everyone's budget. This is undoubtedly the best Sodwana trip of the year so don't miss out!

Courses	Club Member	Non Member
Deep Specialty	R3920	R4070
Advanced	R5248	R5398
Upgrades		
Luxury Ensuite Cabins	R780 per night	
Hut with Linen Toilet & Shower	R385 per night	
Extra Dives	R460 per dive	

JOIN THE CLUB!

MEMBERSHIP BENEFITS:

TRIPS

- Discounts on all trips.
- Free hard gear rental on all trips you do with Scubaversity.

POOL

- Free usage of our pool.
- Free usage of rental equipment when diving at our facility, only pay for your air fill

COURSES

- Discount on all courses
- Discount on all gear

PRIVATE RENTAL

- Discount on private gear rental , only pay for the days you are diving.
- Free printed Scubaversity calendar
- Invite to awesome socials!

AIR FILLS

- Discount on all airfills
- Free first air fill with cylinder hire if you join one of our monthly inland trips.

VIBE WITH YOUR TRIBE

R750 annually

CONTACT US!



THE SUN FISH

UNIQUE TRAITS



Sunfish develop their bullet-like shape because the back fin which they are born with simply never grows. Instead, it folds into itself as the enormous creature matures, creating a rounded rudder called a clavus. Mola being the scientific name are found in temperate and tropical oceans around the world. They are frequently seen basking in the sun near the surface and are often mistaken for sharks when their huge dorsal fins emerge above the water.

MOVEMENT & THREATS TO SURVIVAL

They move awkwardly in the water, wriggling their massive anal and dorsal fins and using their clavus for steering. Though they will also consume little fish, massive amounts of zooplankton, and algae, jellyfish are their preferred meal. Although they are not harmful to humans, they frequently approach divers out of curiosity. Its population is thought to be in a vulnerable state and has a decreasing population trend. Sunfish are often entangled in drift gill nets and may choke on marine debris, such as plastic bags, which mimic the appearance of jellyfish.



JUVENILE

Mola fish are the largest bony fish, with some growing up to 4m tall and 3m wide, weighing almost 2.5 tons. When at a height of roughly 1.7m their skins thickness can be 15cm in width already. Ocean sunfish can get heavily infested with skin parasites, leading them to attract small fish or birds to feed on them. They may even leap up to 3m above the water and splash down to rid themselves of the parasites. They spend most of their time at depths between 300m and all the way down to 1000m but will often come up to the surface for basking.



The Year End Trip you dont want to miss!



MOZAMBIQUE

21-24 NOV

Or make it an 8 day trip till the 28th!

4 Nights 3 Dives **R4999**

Includes hut accommodation, dives, breakfast & supper and a party!
Excludes Tips, Reef Tax and one evening supper which will be on town

IT'S BACK! The legendary Scubaversity Year End Trip! Malongane, a rustic, very quaint and quiet setting close to all the popular reefs and right on the beach. We guarantee an easy going and relaxed atmosphere with professional friendly service – Scubaversity style!

Included in the packages are supers (except one night on the town), eat as much bacon as you like Scubaversity Breakfasts, a braai and then of course the year end function with proper cutlery, fancy table cloths, decorations, but most importantly good times & all you guys!

Courses	Club Member	Non Member
Deep Specialty	R3920	R4070
Advanced	R5248	R5398
Upgrades		

[CONTACT US!](#)



EQUIPMENT EVENING

31 JULY
6:30PM

COME LEARN ALL ABOUT THE CYLINDER PILLAR VALVE!

We are going to show you the inside of a pillar valve and give you the opportunity to disassemble and assemble it yourself! Something fun to do!

[For more information click here](#)

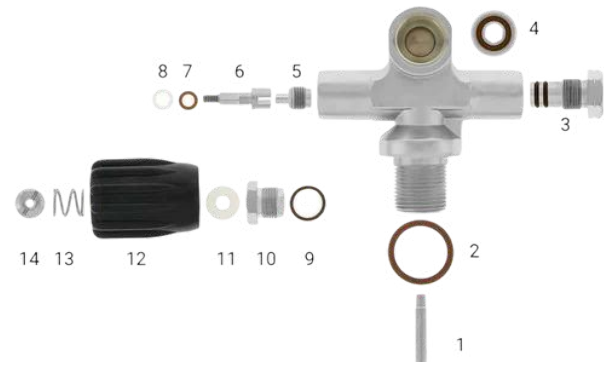

PADI AWARE SIGN THE PETITION TODAY

[CLICK AND SIGN HERE](#)

PADI AWARE will be representing your voice at every step of the development of a new United Nations Global Plastic Treaty. We urgently need your support to influence the decision-makers to ensure we end plastic pollution entering our ocean.

It is the duty of our elected representatives to ensure our oceans are protected from plastic pollution. We implore you to help solve the global plastic pandemic and to champion a strong and effective Global Plastics Treaty that limits single-use plastic production and focusses on reusable products and holds polluters to account.



by Zander Duffield

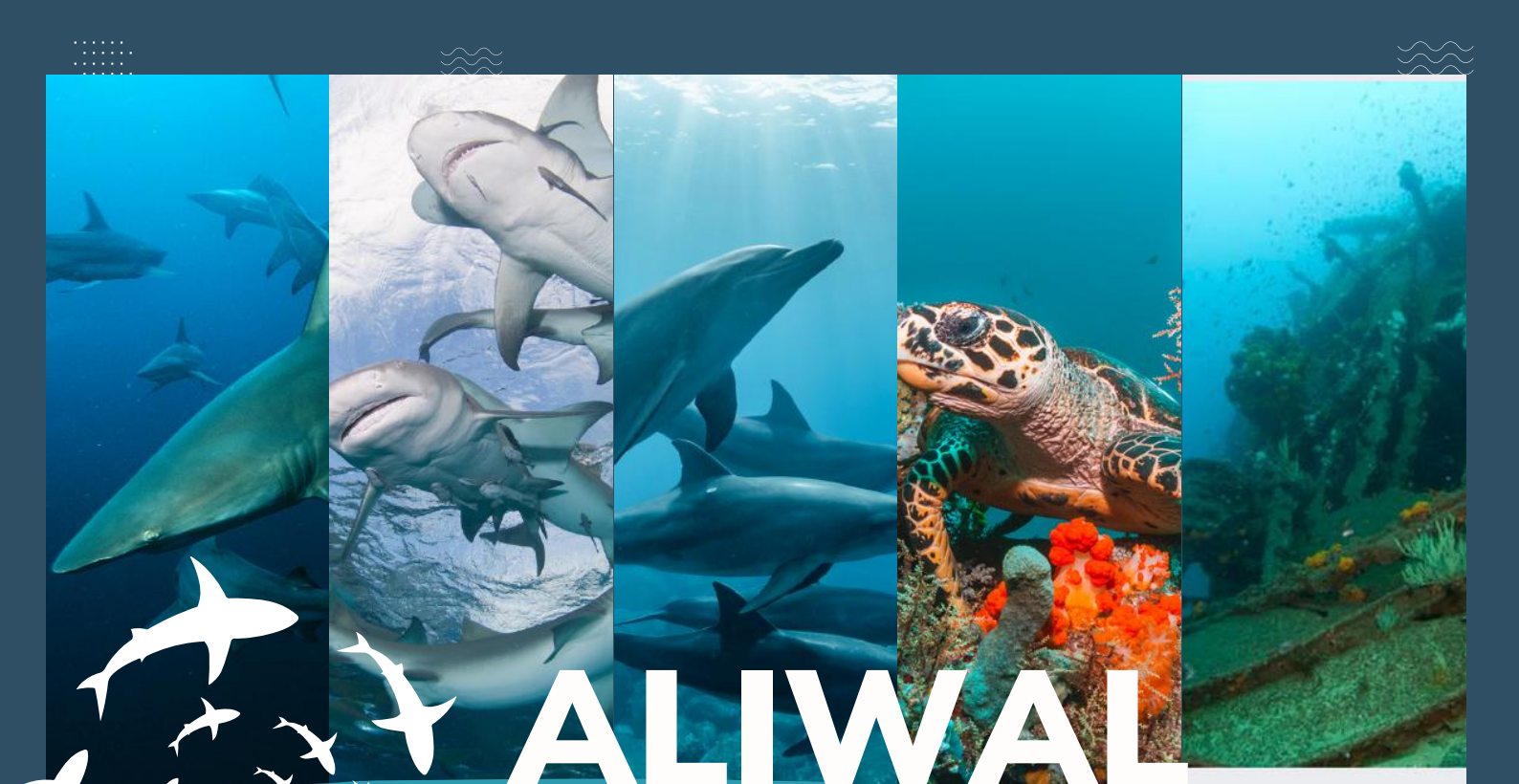

ALIWAL

17-20 OCT

3 Nights 2 Dives **R3750**

Includes Bed, Breakfast and 2 Dives

Join us on an adventure to a small little town called Umkomaas, one of South Africa's biggest diving hubs! Aliwal Shoal is listed in Jacques Cousteau's top 10 dive sites to dive in the world. The reefs are alive with a diversity of marine life that you would travel to multiple destinations worldwide to experience. The reef plays host too many kinds of hard and soft corals and an estimated 1200 species of tropical and subtropical fish. There are two wrecks near the reef that are prime sites for divers. The Nebo which sank in 1884 and the Norwegian bulk carrier called the "Produce" which sank in 1974.

This dive site gives you the opportunity to experience everything that is great about diving Sharks, Wrecks, Reef, Drift and launches that are African style exciting!

Courses	Club Member	Non Member
Deep Specialty	R3920	R4070
Advanced	R5248	R5398
Wreck Specialty	R3920	R4070

[CONTACT US!](#)

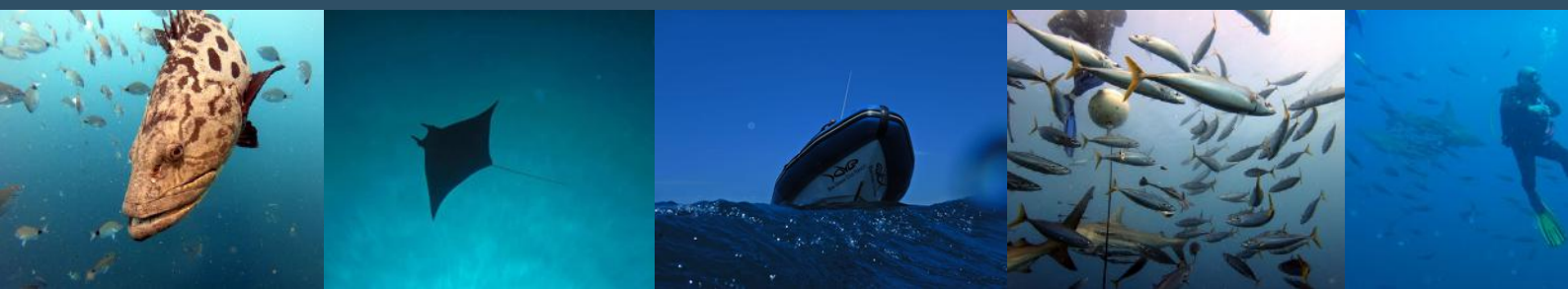

GRAB THESE COURSE COMBO DEALS

PAY NOW AND SAVE!

RESCUE+ EFR COMBO

R6920

YOU SAVE R1 500



DIVE LATER!

NITROX + EQUIPMENT

R5998

YOU SAVE R1 100



ADVANCED + FREE GLOVES

R5598

YOU SAVE R700



AWESOME DEALS FOR YOU!

Terms and Conditions:

Four people are required to run each course.

The course(s) must be completed before the end of the year.

The Combo Deals ends - 31 August

CONTACT US!

by Max du Toit

SEARCH PATTERNS

The next time someone loses an item underwater, you can be the hero that finds the missing object.

The 3 most common search patterns you can use while searching for an item underwater.



U-PATTERN

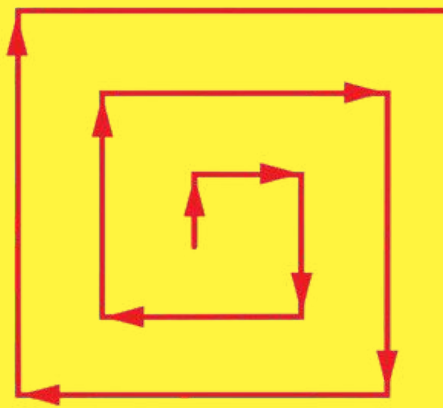

EXPANDING SQUARE

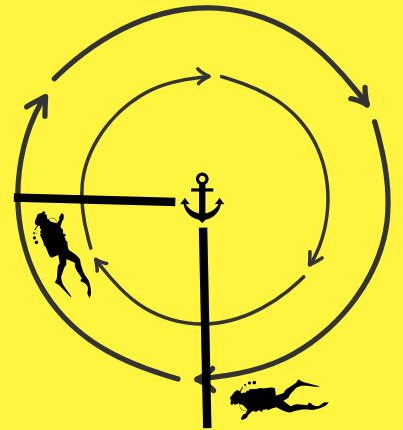

CIRCULAR SEARCH

Finding items underwater is both challenging and rewarding!

WHY TAKE THIS COURSE?

YOU WILL LEARN:

- How to find and recover lost items
- How to use a lift bag
- Search patterns
- Search operations
- Better navigation skills



WHAT WILL YOU BE DOING?

- Swimming search patterns using your compass and natural navigation.
- Locating small and large objects using various search patterns.
- Using a lift bag for large or heavy objects, plus other recovery methods.
- Planning a search operation based on facts gathered about a lost object prior to the dive.

CONTACT US AT:

011 958 2418

dive@scubaversity.co.za

PADI DIVEMASTER COURSE



PADI[®]

The Way the World Learns to Dive[®]



Open doors you have only imagined, as a PADI Professional, you do things others only dream of. Whether you help at Scubaversity, at a resort or on a liveaboard dive boat, the adventure of a lifetime is yours for the taking.

The PADI Divemaster qualification is the first leadership level in the PADI progression. The qualification focuses on a high level of physical diving skills, instructor-level knowledge of diving theory and qualifies you to assume the responsibility for the welfare of other divers.

Imagine a job where you look forward to heading off to work in the morning. Living life others only fantasize about. Sailing into incredible sunsets could be the rule, not the exception, especially if you work in a tropical dive destination. The commute to work could be as easy as a ten-minute boat ride. Work now becomes an adventure. It's not all fun and games in paradise but the rewards are well worth the effort.

This is one of the most rewarding courses diving can offer. If you are at a stage in your diving where you are thinking that you need a bit more, this course is for you. It is the ideal opportunity for the serious diver with ambitions in personal self-development or just achieving a professional level in diving. Maybe you need a desperate change and are considering kissing the corporate world goodbye, going the professional diving route could be just what you are looking for!

31 JULY 2024

CONTACT US AT:
082 852 8253
mandy@scubaversity.co.za



GAP WEEK

your time in the sun

How one week would impact my whole life

Hey, my name is Ethan Kehagias, and I'm a blue ocean intern working here at Scubaversity. Before coming to work here, I had no direction in my life. I was lost, but more prominently, I was alone. I didn't know what or who I wanted to be in life. My hobbies became mundane, and little things brought me joy or excitement. Then one day, on a whim, I decided to partake in the Scubaversity gap week during my school break. Suddenly, everything made sense, it was an eye-opening experience. I had started diving already in 2019, but experiencing what it's like to live and work at Scubaversity, that's living a proper lifestyle.

To say the gap week was a one-in-a-lifetime experience would be an understatement. It was some of the most fun I had in a long while, so much so that it influenced me enough to take the leap and sign up for the Blue Ocean Internship, and the fun just kept getting better ever since. The connections and friends I have made along the way, I feel that we will always share a connection, a bond, that even if we lost contact, we will always remember each other and the incredible memories we share diving and working together in this incredible industry. I will never forget these moments and if I was given a second chance at life, I wouldn't change a thing.

[CONTACT US!](#)

by Ethan Kiagias

WHY DO THE GAP WEEK?

01

To find out and learn more about the scuba diving industry.

02

To advance your scuba diving knowledge and skills.

03

Something to do over the school holidays, not just sitting at home.

04

Have loads of fun, meeting new people and making lots of memories!

GAP WEEK PROGRAM R3 799 P/P

- AGES 16-18
- Accommodation provided
- All food provided
- 26-29 September



DIVE WORK

- Rescue exercise workshop, unresponsive diver and different diver tows.
- Basic Freediving pool work.
- Peak performance buoyancy workshops fixing weights and trim.
- Basic Skill demonstration, intro to dive master.



TEAM BUILDING

- Build a raft with anything on Scubaversity property.
- Make breakfast and supper for everyone in specified teams.
- EFR and CPR introduction, STAYING ALIVE! Bandaging as well
- Set up camp site on beach and make a bonfire! And let's not forget the pootjie on the beach



FUN ACTIVITIES

- Volleyball on the beach while having a braai
- Stalk the lantern on the property
- Movie night at the dive centre and let's not forget the popcorn
- Dance-asize upstairs in the morning
- Games and Pizza evening

THE DIFFERENCE BETWEEN OPEN, SEMI-CLOSE AND CLOSED CIRCUIT

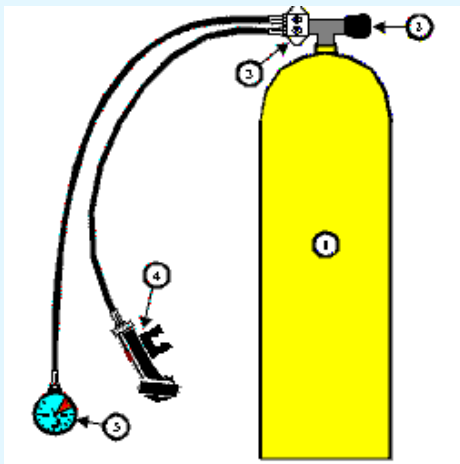

1 OPEN CIRCUIT REGULATOR

When a diver inhales, they breathe from a compressed gas cylinder. This is known as a demand system. When a diver exhales, the breath vents into the water and bubbles to the surface i.e. exhaled air is released directly into the water. It means that the path of air from the cylinder terminates when it is exhaled into the water.

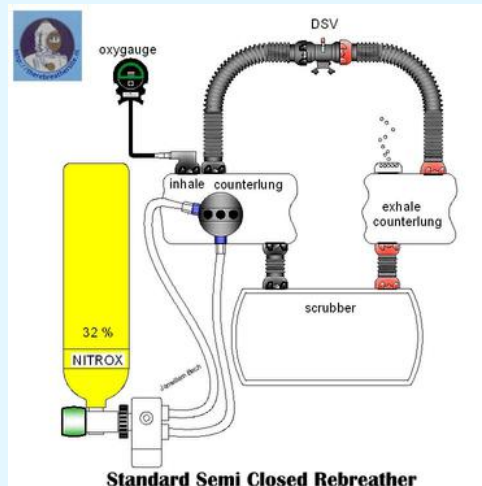

2 SEMI-CLOSED CIRCUIT

The diver inhales, from a bag or counter-lung, and the exhaled breath cycles through a system that removes waste carbon dioxide and returns it to the counter-lung. It replaces consumed oxygen by employing a slow steady flow of oxygen into the counter-lung resulting in a slow, small stream of bubbles.

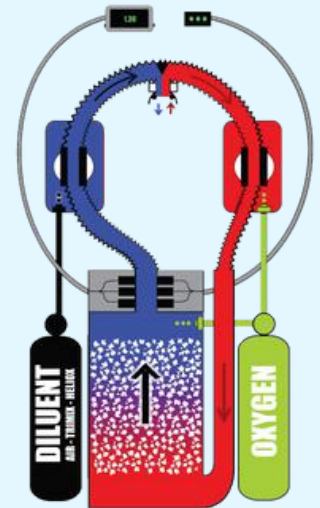

3 CLOSED-CIRCUIT

The inhaled breath comes from a bag/counter-lung, and when exhaled, is then cycled through a system that removes waste carbon dioxide and replaces the consumed oxygen, then returned to the bag. There are no bubbles.

[CONTACT US!](#)

AIR ENDURANCE

The steps needed to calculate your air consumption before and during a dive

For any dive, it is vital that a pre-dive plan is drawn up. It is paramount that you plan your dive in detail and brief the dive with your fellow divers before hand. This includes taking into account your air consumption before and after a dive, we can use the SAC rate to calculate our overall air endurance for a dive.

HOW DO I CALCULATE SAC RATES:

Firstly, there are some things one must take into consideration.

- cylinder size
- start air pressure
- end air pressure
- average depth
- dive duration

For reference

- a dive to 27 meters
- for a duration of 42 minutes
- on a 15 litre cylinder
- with a start pressure of 212 bar
- and an end pressure of 53 bar
- and an average depth of 21.56 meters

To calculate an SAC rate;

- Start by subtracting your start and end pressure.
- In this case, it would be 212-53, which gives us 159.
- Multiply this answer with the size of the cylinder, 159x15 which equals 2385.
- Next, divide this by the dive duration. 2385 divided by 42 equates to 56,79 litres per minute under water.
- Lastly, taking into consideration the absolute pressure, which in this case would be 3,7
- Finally, divide your air consumption underwater with your atmosphere pressure, 56.79 divided by 3.7 equals 15.34 litres per minute.
- Therefore, your SAC rate would be 15.34 litres of air consumed per minute.

OUR AIR ENDURENCE:

To calculate our air endurance we use the formula:

$$\text{air endurance} = \frac{\text{total air-reserve air}}{\text{SAC x absolute pressure}}$$



[CONTACT US!](#)

by Ethan Kiagias

Ears in Diving

OUTER EAR

The outer ear is the part that sticks out your head and catches all the sound, it is connected to the ear canal which travels to the eardrum.

- When we dive or swim, the ear canal is filled up with water which causes no damage if the ear drum is healthy and there are no holes or tears in it, therefore no water will flow into the middle ear.

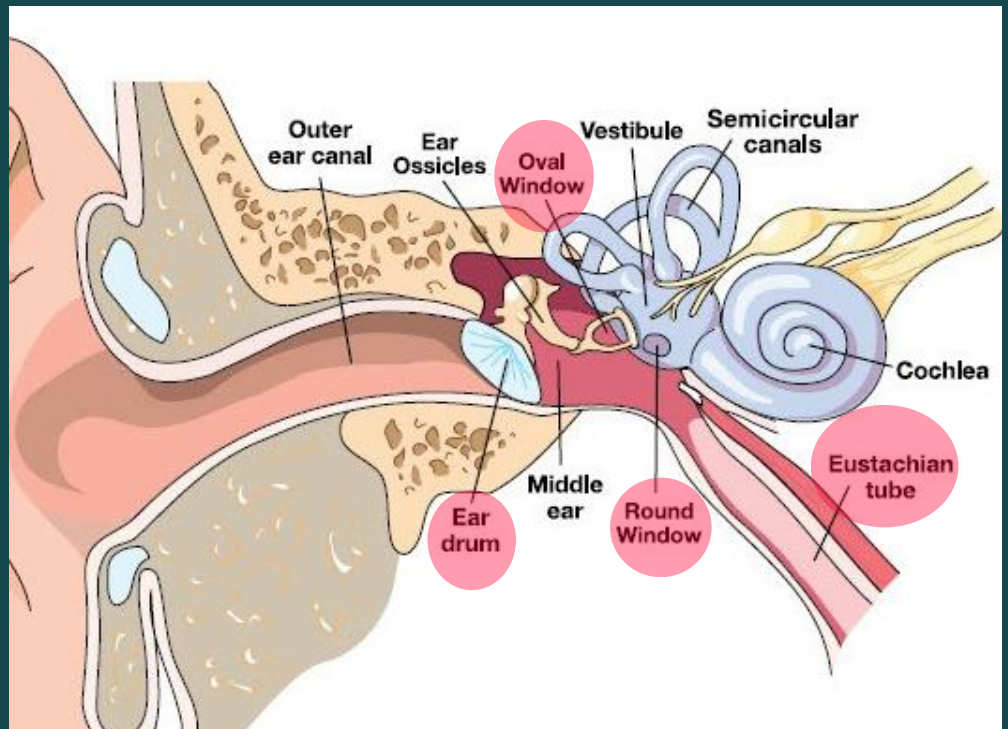

MIDDLE EAR

The middle ear contains the eardrum which vibrates when sound waves come into contact with which then goes to the inner ear which allows us to hear.

- The middle ear is connected to the back of the throat by the Eustachian tube. When we pinch our noses and blow, it forces air from the lungs up the Eustachian tube which then balances the pressure in the ear.
- When descending If you do not equalize your middle ear and too much pressure build up, you can suffer a middle-ear barotrauma (MEBT). This occurs when the pressure difference causes the eardrum to bulge inward, leading to pain, fluid buildup, and potentially a ruptured eardrum.
- Symptoms of MEBT include ear pain, muffled hearing, dizziness, and in severe cases, bleeding
- The best way to prevent this is to simply equalize early and often and not only when you feel pain.

INNER EAR

The inner ear contains a lot smaller and more delicate parts than the rest of the ear, its what allows us to hear and and equalize as the Eustachian tube is part of it.

- When blowing (equalizing) against a blocked nose, it raises your internal fluid pressure, including the fluid pressure in your inner ear, which may rupture your "round windows." So don't blow too hard, and don't maintain pressure for more than five seconds.
- If you do not equalize on descent, the pressure on the eardrum will transfer through the middle ear ossicles to the oval window resulting in the round window to bulge outwards. If there is excessive pressure either the oval or round window may tear and inner ear fluid will leak into the middle ear.
- This may result in symptoms like hearing loss, off balance, vertigo and tinnitus.

WE WILL BE HOSTING AN ONLINE NITROX COURSE

THUR, 15 AUG 18:30



ONLY R2 999

Scubaversity is hosting their very first online speciality course on Zoom! On the 15th of August we will be sending invites to those who are interested in joining in on the course. In these cold times we don't really want to leave the comfort of our cozy homes. Now you can relax on the couch, make a cup of coffee and learn how to dive with enriched air nitrox!

The PADI Enriched Air Diver course is PADI's most popular specialty scuba course. Why? Because scuba diving with enriched air nitrox gives you more no decompression time, especially on repetitive scuba dives. If staying down longer and getting back in the water sooner sounds appealing, then don't hesitate to become an enriched air diver.

CONTACT: MANDY [082 852 8253](tel:0828528253) FOR MORE INFO

**[Sign up now for your
Qualifying weekend](#)**

by Zander Duffield

RESCUE



No doubt one of the most fun and exciting courses we offer, rescue not only helps you to become a more confident diver, but also a safe one. The course consists of three sections, knowledge development, which will take place as a lecture in one of our classrooms, as well as homework and tests. Second is skills development and practice exercises, which would take place in our five meter deep pool with one of our very talented dive instructors there with you. and third is the practical open water scenarios, where everything you learned is put to the test.

The PADI Rescue Diver course will change the way you dive – in the best possible way. Learn to identify and fix minor issues before they become big problems, gain a lot of confidence, and have serious fun along the way.

Discover why countless divers say Rescue Diver is their favorite scuba course.

Take This Course If You Want to:

- **Be a better dive buddy.**
- **Improve your navigation skills.**
- **Enroll in a divemaster course.**
- **become more aware and capable of handling tense situations**
- **Become more knowledgeable of safety procedures and first aid.**



Genuinely the most fun and memorable courses I have ever taken!

for more info visit

www.scubaversity.co.za

[CONTACT US!](#)

by Ethan Kiagias

COURSES OF THE MONTH



DEEP

16 Aug 6:30pm-9pm

[Sign up now for your Qualifying weekend](#)

[Sign up now for your Qualifying trip](#)

As you descend into the quite dark of the ocean, the cool waters caress your weightless body, and the golden rays of sun light slowly meld into the deep blue of the great deep sea, its mysteries intrigue you.

In deep diving, you will learn the safety procedures of how to descend and ascend safely using a dive computer. You will also learn to master your buoyancy. What's more, despite the lack of sunlight in some places, entire ecosystems and marine life thrive in the depths where you wouldn't be able to find them anywhere else.



WRECK

16 Aug 6:30pm-9pm

[Sign up now for your Qualifying Trip](#)

Whether purpose-sunk as an artificial reef for scuba divers, or lost as the result of an accident, wrecks are fascinating windows to the past.

Ships, airplanes and even cars are fascinating to explore and usually teem with aquatic life. Each wreck dive offers a chance for discovery, potentially unlocking a mystery or spying something others have missed.

The PADI Wreck Diver Specialty course is popular because it offers rewarding adventures while observing responsible wreck diving practices.



RESCUE

6 Aug 6:30pm-9pm

[Sign up now for your Qualifying weekend](#)

"Challenging" and "rewarding" best describe the PADI Rescue Diver course. Building upon what you've already learned, this course expands on what you already know about how to prevent problems, and how to manage them if they occur.

As one of our most fun and exciting courses, it's no wonder it's so popular. Learn useful medical skills such as basic first aid, emergency oxygen provider, and do it all while having an absolute blast!

So don't miss this course and the opportunity to have an awesome adventure!

[CONTACT US!](#)

THE CUSTOM WETSUIT

[CONTACT US!](#)



OWN YOUR OWN FOR ONLY

R 6 600

DESCRIPTION

If you are looking for a quick and easy solution for getting cold on dives, here it is! This wetsuit is hands down one of the best. With it's super soft inside making it super easy just to slip in to at any time and keeping you very warm. The neoprene is also very stretchy so once you've got it on it sort of molds to your body. If you're looking for even more warmth you can get the two-piece wetsuit which will give you double layers on your chest and torso!



ITS FULLY CUSTOMISED

Yes, the Rob Allen wetsuits are fully customizable, meaning you measure every centimetre of your body and they make the wetsuit according to your body measurements.

FEATURES

- Rob Allen Digital Camo Pattern
- Super Stretch Ultraspan Fabric
- Fully Glued & Blind Stitched
- Chest Loading Pad & Knee Pads
- Beavertail Fastener with Dual Locking Clips



CLUB OF MEMBER OF THE MONTH

Jizelle Fischer

Jizelle, we take this time to thank you for everything you have done for Scubaversity since the day you joined in December of 2023! You've always shown massive support towards our projects and petitions. You are such a delight to be around, with your warm hearted personality and your will to have fun. Not scared to take your bakkie for some good old 4x4'ing on the sand dunes in Sodwana and even helping in the kitchen. We love your dedication and passion for diving. Seeing you and your son, Austin, becoming great cooperative dive buddies and great divers in general. Keep on being this awesome person that you are and we at Scubaversity will love you forever!



COMMON EQUIPMENT PROBLEMS AND THEIR SOLUTIONS

[CONTACT US!](#)

MASK

Water in mask



CAUSE

Some of the causes for a leaking mask include a torn skirt, improper fit, leaky purge valve, hoods, and hair under the skirt.

SOLUTION

Visual inspection, check the straps for cracks, ripped skirt, and other anomalies. Inhaling to test before dive.

SNORKEL

Unable to clear



CAUSE

Some causes may include a leaky self drain, or it is incorrectly placed on head or in mouth

SOLUTION

be sure to do a pre dive check before and after entering the water to make sure it is indeed functioning.

FINS

Cramp



CAUSE

We've all experienced cramps, but do we know the cause of said cramp? Some causes include fins that are too large or stiff, foot pocket too small, and strap or bootie too tight.

SOLUTION

Check fins for fit, comfort, and adjust prior to dive.

REGULATOR

Free flow



CAUSE

A common problem among divers, some causes may be due to poor maintenance, a dented cover, foreign matter in regulator, and freezing.

SOLUTION

proper routine maintenance is key, as well as servicing and using anti-freeze provisions. What also helps is keeping the second stage inside clear.

BCD

Overly Buoyant



CAUSE

It's common for new divers to become overly buoyant, some of the causes for this include having air in the suit, or being underweighted. However, it mainly just comes down to practice and skill.

SOLUTION

Check if you are properly weighted as well as know and maintain your gear. Test before dive.

WET SUIT

Breathing difficulty



CAUSE

There is a simple cause for having difficulty breathing when wearing a wet suit, it may be too tight.

SOLUTION

Much like the cause, the solution is also simple, check for a suit that properly fits you when buying a wet suit.

by Ethan Kiagias

CLUB ALBUMS | PLAN YOUR TRIPS

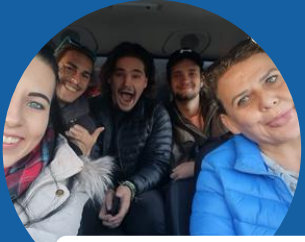

ALI WAL/LESOTHO



INHAMBANE



OUTDOOR X



SODWANA

MARICO OOG

23-25 August

SODWANA

20 - 24 September

ALI WAL

18-20 October

MOZAMBIQUE

21-28 November

PHILIPPINES

26 Dec - 5 Jan

[CONTACT US!](#)

SYNC YOUR CALENDER WITH OURS

[click here to sync with](#)



scubaversity
it's a lifestyle!

AUGUST

MON	TUE	WED	THU	FRI	SAT	SUN
			1	2	3 SOCIAL	4 OPEN WATER
5	6 RESCUE	7	8	9	10	11 POOL SESSIONS
12 WRECK	13 DEEP	14	15 NITROX ADVANCED	16	EGYPT INLAND TRIP	
RED SEA 16 - 25 AUG				MARICO OOG		
26	27	28 EFR	29	30	31	

011 958 2418
dive@scubaversity.co.za
www.scubaversity.co.za

Have you taken the plunge into refreshing spring water yet?

Sodwana
Marico Oog
Mozambique

20 - 24 Sept
25 - 27 Oct
21 - 24 Nov



SEPTEMBER

MON	TUE	WED	THU	FRI	SAT	SUN
						1 OPEN WATER
2	3 RESCUE	4	5	6	7 SOCIAL	8 POOL SESSIONS
9	10	11	12 NIGHT	13	14	15 INLAND TRIP
16	17 DEEP FISH ID	18	19 ADVANCED	20	SODWANA	
20-24 SEPT				25 EFR	26	27 OPEN WATER

011 958 2418
dive@scubaversity.co.za
www.scubaversity.co.za

A birthday party is coming up, and it's promised to be a wild time.

Marico Oog
Mozambique
Marico Oog

25 - 27 Oct
21 - 24 Nov
18 - 20 Oct

JOIN OUR BLUE OCEAN INTERNSHIP



THE BEST WAY TO SPEND YOUR GAP YEAR!

Scubaversity's Blue Ocean Program is an exciting opportunity! During this fun year, you'll learn to become a PADI Scuba Diving Instructor and gain solid industry experience. Plus, you'll walk away with a CV showcasing work experience in a reputable scuba diving business and a solid reference letter. It's a fantastic way to kickstart your career in diving!

For more information
contact:

mandy@scubaversity.co.za
[011 958 2418](tel:0119582418)

**BLUE
OCEAN
PROGRAM**



JOIN OUR SOCIAL MEDIA CHANNELS !

SUBSCRIBE BY CLICKING HERE

NEVER MISS AN ISSUE!

- Enjoy huge savings
- Free home delivery via e-mail / whatsapp
- Get your copy before everyone else

WWW.SCUBAVERSITY.CO.ZA

- Catch the freshest features
- Updated monthly
- Read anytime, anywhere



INSERTS AND ORINGS

www.scubaversity.co.za
dive@scubaversity.co.za
011 958 2418 Dive Center
083 616 4066 WhatsApp

