

# Products

# 2023



**zanotta:**



# Index

8-57

Divani  
Sofas  
Canapés  
Sofas  
Sofás

58-81

Poltrone  
Armchairs  
Fauteuils  
Sessel  
Butacas

82-105

Tavolini  
Small tables  
Petites tables  
Couchtische  
Mesitas

106-131

Sedie  
Chairs  
Chaises  
Stühle  
Sillas

132-161

Tavoli, consolle, scrivanie  
Tables, console tables, desks  
Tables, consoles, tables bureau  
Tische, Wandtische,  
Schreibtische  
Mesas, consolas,  
mesas escritorios

178-205

Complementi d'arredo  
Furnishing accessories  
Compléments d'ameublement  
Wohnaccessoires  
Complementos de decoracion

# Products

## A

Albero 180  
Alfa 10  
Allunaggio 230  
Ambrosiano 134  
April 108  
Arabesco CM 84  
Ardea CM 60  
Arom 61  
Aster 182

## B

Basello 85  
Blanco 136  
Bol 138 **NEW**  
Box 164  
Bruce 14  
Bumper 18 **NEW**  
Butterfly 86

## C

Calamo 140  
Calla 62  
Campiello+ 63  
Carlino CM 87  
Cavour CM 142  
Celestina 109  
Chichibio 183  
Club 22  
Comacina 144  
Confortevole 176  
Cumano 88

## D

Daisy 114 **NEW**  
Dan 110  
Dan 112  
Dan Outdoor 113  
Derby 64

## E

Echino 89  
Elica 146  
Elica 147

## F

Fenice 148  
Fenis CM 116  
Flamingo 24  
Follia 184  
Formaplust 176

## G

Galeotta 67 **NEW**  
Genni 65  
Gilda CM 66  
Giotto 185  
Girò 90  
Grangala 166  
Graphium 91

## I

Ido 117

## J

Joy 186

## K

Karelia 68  
Kent 69  
Kilt / Kilt 84 28

## L

Lama 71  
Lea 118  
Lealta 119  
Leonardo 149  
Lia 120  
Lialta 121  
Lio/Leo 122  
Liza 124  
Lord 125

## M

Maggiolina 72  
Marcuso 150  
Mezzadro 187  
Milano 168  
Milano+ 32  
Milleunanotte 170  
Milo CM 188  
Mollaplust 176  
Molleggio 176  
Moretta 73  
Museo 189

## N

Natura 176  
Nena 126  
Nena Lounge 74 **NEW**

Nena Stool 127

Niobe 92

Noah 34

Nyx 171

O

Oliva 76

Onda 38

Orione 151

Oscar 93

P

Parco 39

Pianoalto  
/ Pianoalto 96 40

Pisolo 177

Poker 152

Primate 190

Q

Quaderna Carpet 191

Quaderna  
Coffee Table 94

Quaderna Consolle 156

Quaderna  
Cupboard 192 NEW

Quaderna Desk 154

Quaderna Mirror 194 NEW

Quaderna  
Sideboard 193 NEW

Quaderna  
Small Table 95

Quaderna Table 153

Quaderna  
Writing Desk 155

R

Raperonzolo 195

Reale 157

Reale CM 158

Ricordi 172

Rider 77

S

Sacco 78

Sacco Medium 78

Sacco Small 78

Sant'Elia 80

Sciangai 196

Sciangai 50 197 NEW

Sella 198

Servento 199

Servietto 202

Servobandiera 201

Servofumo 203

Servomanto 204

Servomuto 96

Servonotte 202

Servopluvio 203

Servostop 200

Sgabillo 97

Shiki 44

Susanna 81

T

Talamo 174

Talia 128

Taschino 98

Tempo 99

Teti 100

Throw-Away 48

Tod 101

Toi 102

Tonietta 129

Topper 176

Toto 103

Tucano 159

Tusa High 130

Tusa Low 131

Tweed 160

Tweed Marble 161 NEW

Tweed Mini 104

W

William 50

Z

Za:Za 56

Zeus 105

# Designers

## A

Atelier Oï  
Gae Aulenti

## B

Roberto Barbieri  
Liisi Beckmann  
Max Bill  
Piero Bottoni  
Todd Bracher

## C

Calvi Brambilla  
Louise Campbell  
Federica Capitani  
Achille e Pier Giacomo  
Castiglioni  
Achille Castiglioni  
Joe Colombo

## D

De Pas - D'Urbino -  
Lomazzi  
Anna Deplano  
Rodolfo Dordoni  
Alessandro Dubini  
Noé Duchaufour  
Lawrance

## E

Emaf Progetti

## F

Monica Förster

## G

Garcia Cumini  
Gatti - Paolini -  
Teodoro  
Guisset Constance

## H

Alfredo Häberli  
Sebastian Herkner

## I

Salvatore Indriolo

## L

Willie Landels  
Lanzavecchia + Wai  
Bertrand Lejoly  
Gino Levi Montalcini  
Lievore, Altherr, Molina

## M

Enzo Mari  
Bernard Marstaller  
Mist-o  
Carlo Mollino  
Gabriele Mucchi

## N

Patrick Norguet

## P

Giuseppe Pagano  
Pogatschnig  
Ludovica+Roberto  
Palomba

## R

Prospero Rasulo  
Frank Rettenbacher  
Gabriele Rosa

## S

Spalvieri & Del Ciotto  
Superstudio

## T

Alexander Taylor  
Giuseppe Terragni

## W

Damian Williamson

## Z

Marco Zanuso  
Zaven  
Jacopo Zibardi







*Divani*  
*Sofas*  
*Canapés*  
*Sofas*  
*Sofás*



Design

Emaf Progetti

1999

**Poltrona, divani monoblocco, componibili, pouf**

Piedini in acciaio cromato, o nichelsatinato colore naturale o nero, oppure verniciato colore grafite. Struttura in acciaio. Molleggio su nastri elastici. Imbottitura in poliuretano/ fibra poliestere termolegata. Rivestimento sfilabile in stoffa o in pelle, con cuscino seduta trapuntato. Cuscinetti in Dacron Du Pont o piumino d'oca.

**Armchair, monobloc, modular sofas, poufs**

Steel feet, chromium-plated or varnished graphite, or with natural or black nickel-satin finish. Steel frame. Elastic strips suspension. Upholstery in polyurethane/ heat-bound polyester fibre. Fabric or leather removable cover with quilted seat cushion. Small cushions in Dacron Du Pont or in goose down.

**Fauteuil, canapés monoblocs, composables, poufs**

Pieds en acier chrome ou nickel satiné, dans les couleurs naturel ou noir, ou verni couleur graphite. Structure en acier. Suspension sur sangles élastiques. Rembourrage en polyuréthane/fibre polyester liée à chaud. Revêtement avec coussin assise surpiqué, déhoussable en tissu ou en cuir. Coussinets en Dacron Du Pont ou en duvet d'oie.

**Sessel, einteilige – zusammenstellbare Sofas, Hocker**

Füße aus Stahl, verchromt oder mit naturfarben- oder schwarz- vernickeltem und mattiertem Finish oder Graphit lackiert. Gestell aus Stahl. Federung mit elastischen Gurten. Polsterung aus Polyhurethan/ wärmegebundener Polyesterfaser. Abnehmbarer Bezug mit Steppung über den Sitzpolstern aus Stoff oder Leder. Kleine Kissen aus Dacron Du Pont oder aus Gänsedaunen.

**Butaca, sofás monobloque, modulares, púfs**

Pies de acero cromado, o niquelado mate en los acabados natural o negro o pintado color grafito. Estructura de acero. Suspensión sobre cintas elásticas. Acolchado de poliuretano/fibra poliéster termounida. Tapizado desenfundable de tejido o de piel, con cojín del asiento respunteado. Cojines de Dacron Du Pont o de plumón de ganso.

Piedini/Feet/Pieds/Füße/Patas



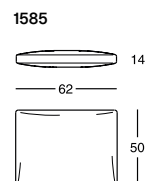
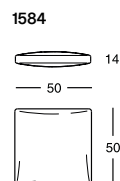
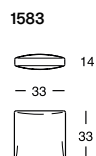
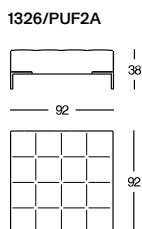
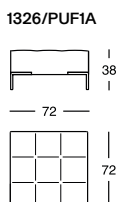
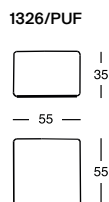
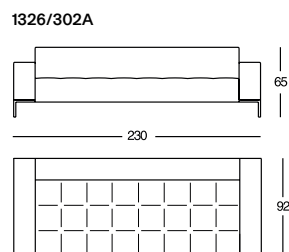
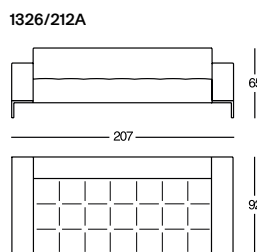
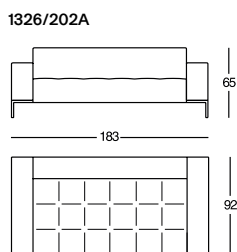
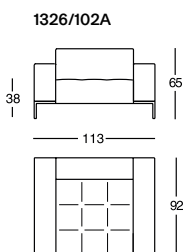

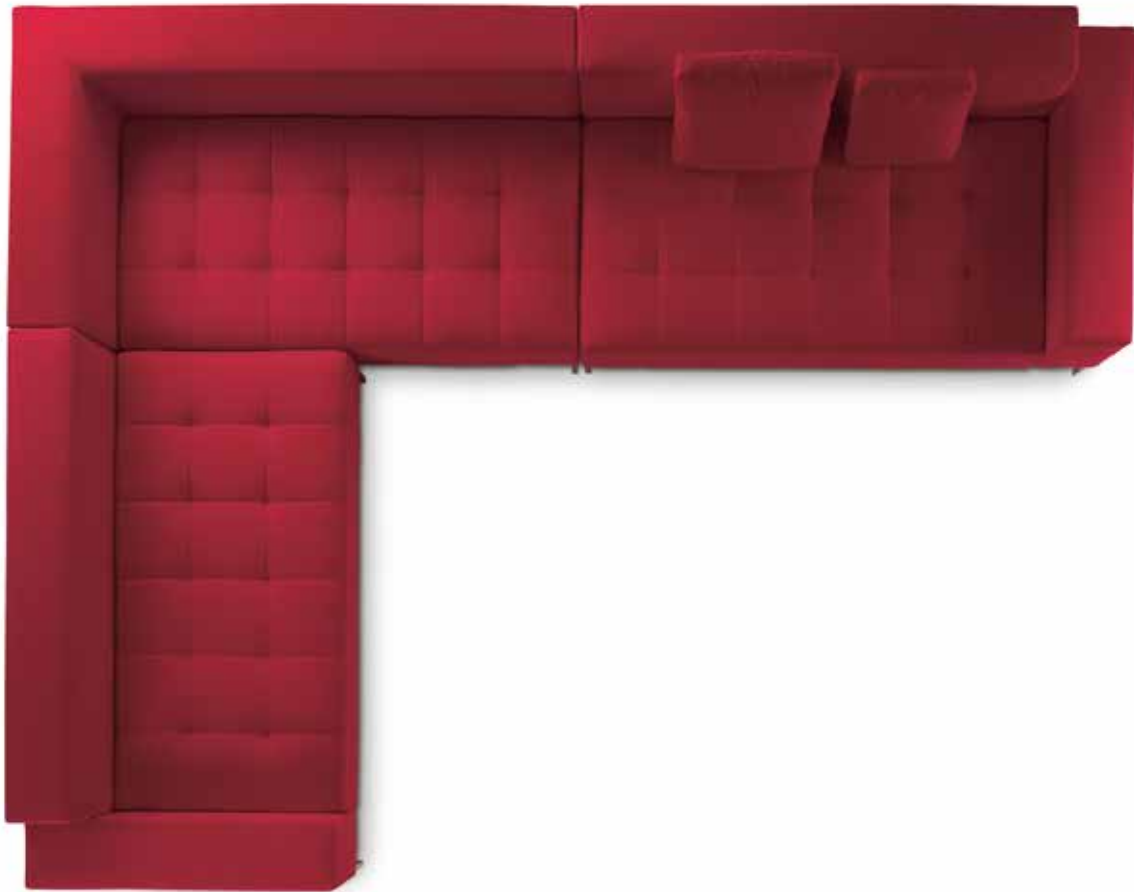

1326/DORA

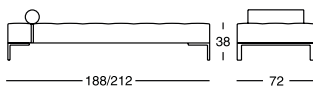

1326/AL1

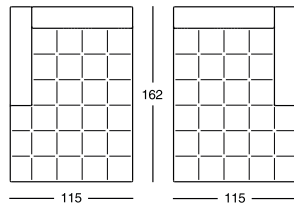

1326/ALP1

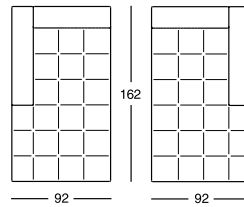

1326/ANGA

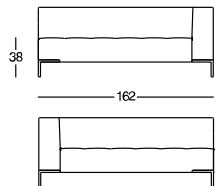

1326/201A

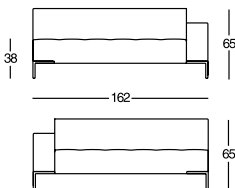

1326/301A

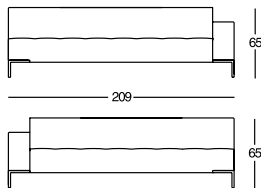

1326/201TA

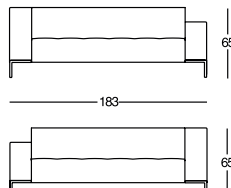

1326/301TA

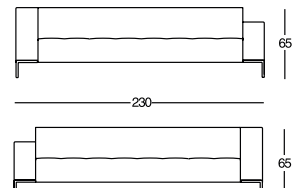

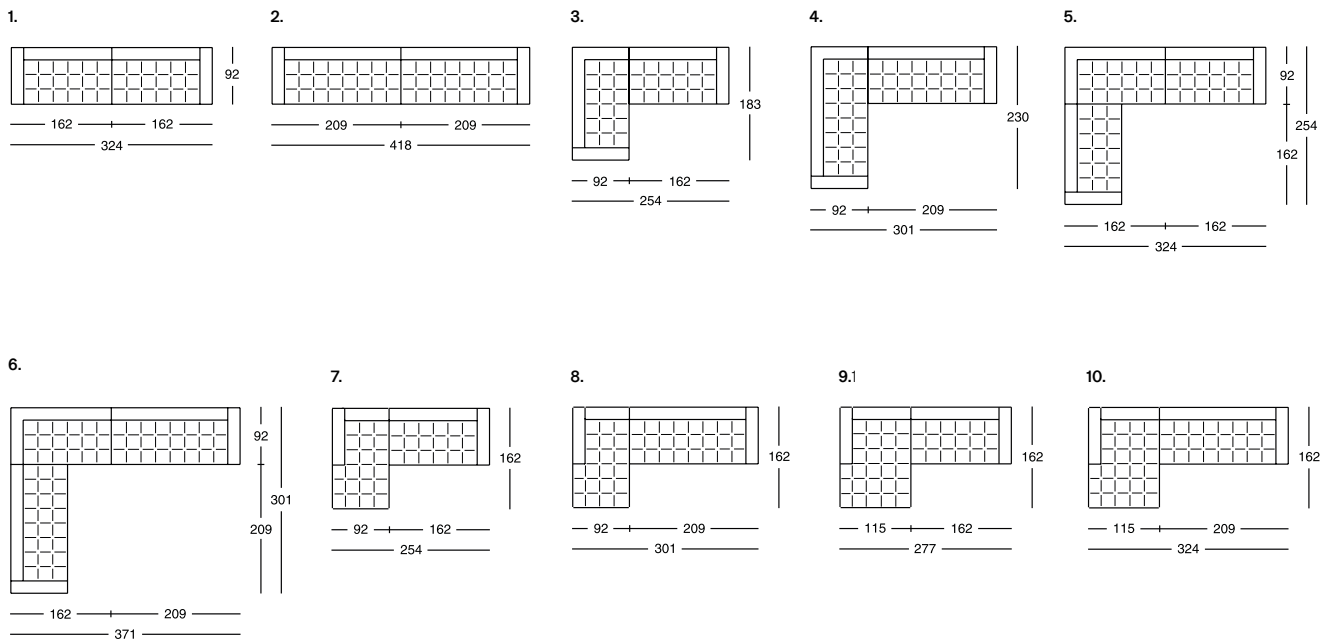

# Bruce <sup>1335</sup>



Design

Ludovica+Roberto Palomba

2013

**Divani monoblocco, componibili, pouf**

Piedini in lega di alluminio lucidato, nichelsatinato colore naturale o nero, oppure verniciato colore nero. Struttura in acciaio. Molleggio su nastri elastici. Imbottitura in poliuretano/Dacron Du Pont. Cuscino seduta in poliuretano/

Dacron Du Pont. Cuscini schienale e bracciolo in piuma d'oca. Imbottitura rullo in poliuretano/fibra poliestere termolegata. Rivestimento sfilabile in stoffa o pelle.

**Monobloc and modular sofas, pouf**

Polished aluminum alloy, or with natural or black nickel-satin finish, or black painted. Steel frame. Elastic strips suspension. Upholstery in polyurethane/Dacron Du Pont. Seat cushion in polyurethane/Dacron Du Pont. Back and armrest

cushions in goose feather. Upholstery of roll-shaped cushion in polyurethane/heat-bound polyester fibre. Removable cover in fabric or leather.

**Canapés monoblocs, composables, pouf**

Pieds en alliage d'aluminium poli ou nickel satiné, dans les couleurs naturel ou noir, ou verni noir. Structure en acier. Suspension sur sangles élastiques. Rembourrage en polyuréthane/Dacron Du Pont. Coussin du siège en polyuréthane/Dacron Du

Piedini/Feet/Pieds/FüÙe/Patas





Pont. Coussins du dossier et accoudoir en plumes d'oie. Rembourrage de cale-reins en polyuréthane/fibre polyester liée à chaud. Revêtement déhoussable en tissu ou en cuir.

**Einteilige, zusammenstellbare Sofas, Hocker**  
Füße aus Aluminiumlegierung, poliert oder mit naturfarben oder schwarz- vernickeltem und mattiertem Finish, oder schwarz lackiert. Stahlgestell. Federung auf elastischen Gurten. Polsterung aus

Polyurethan/Dacron Du Pont. Sitzkissen aus Polyurethan/ Dacron Du Pont. Rücken und Armlehne-Kissen aus Gänsfedern. Polsterung der Nierenrolle aus Polyurethan/ wärmegebundener Polyesterfaser. Abnehmbarer Bezug aus Stoff oder Leder.

**Sofás monobloques, modulares, puf**  
Patas de aleación de aluminio pulido o niquelado mate en los acabados natural o negro, o pintado negro. Estructura de acero. Suspensión sobre cintas elásticas. Acolchado de poliuretano/Dacron

Du Pont. Cojín asiento de poliuretano/Dacron Du Pont. Cojines de respaldo y apoyabrazo de pluma de ganso. Acolchado de cojín lumbar de poliuretano/ fibra poliéster termounida. Tapizado desenfundable de tejido o piel.

1335/202

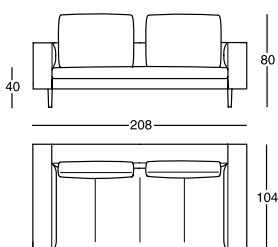

1335/212

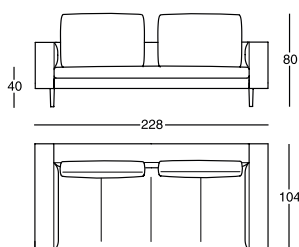

1335/302

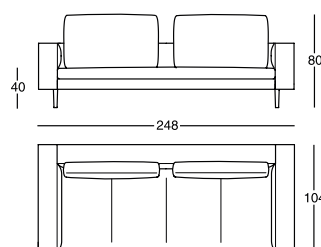

1335/PUF

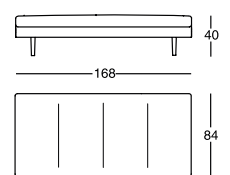



1335/201

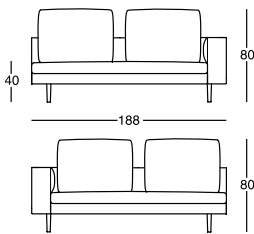

1335/301

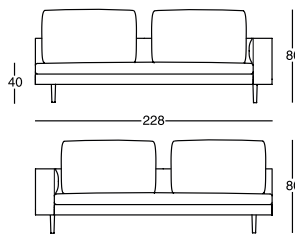

1335/200

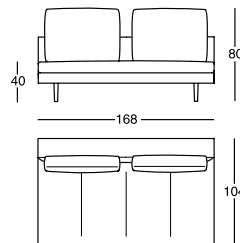

1335/300

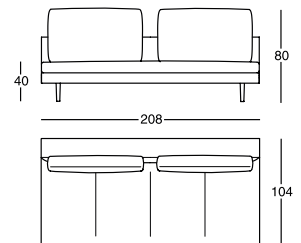

1335/200P

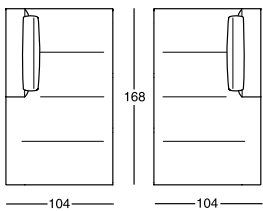

1335/300P

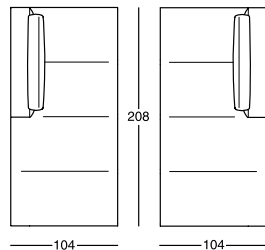

1335/ALP1

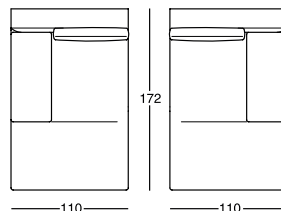

1335/AL1

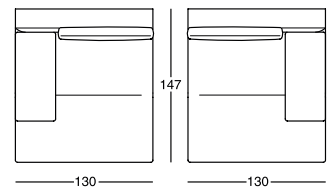

1335/70C

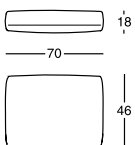

1335/90C

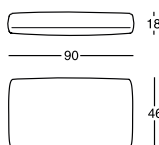

1335/70R

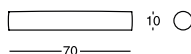

1335/BRA

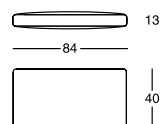





1.

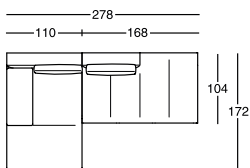

2.

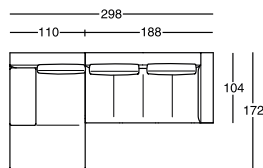

3.

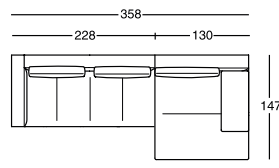

4.

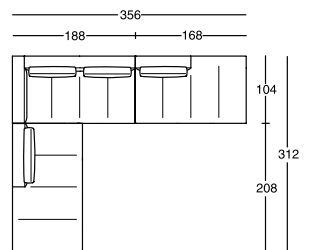

5.

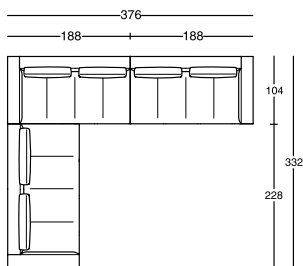

6.

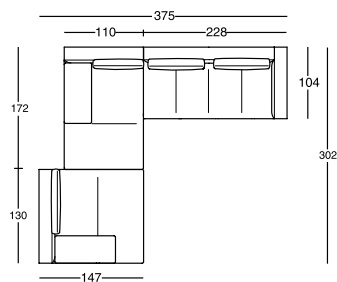

7.

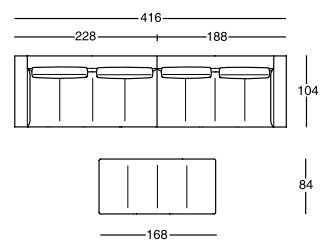

8.

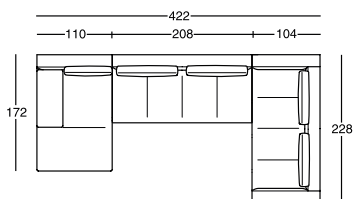

9.

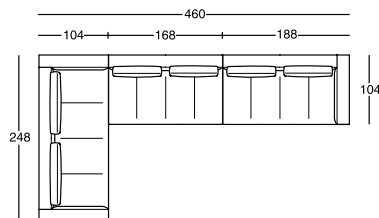

10.

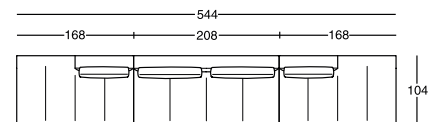

# Bumper<sup>1265</sup>



Design

Calvi Brambilla

2023

**Divani monoblocco e componibili, pouf e cuscino**

Struttura in legno. Imbottitura sedile, schienale e base in poliuretano a quote differenziate/ Dacron Du Pont. Cuscino in fiocchi di poliestere rigenerato e rigenerabile. Rivestimento sfilabile in stoffa.

**Monobloc and modular sofas, pouf and cushion**

Wooden frame. Seat, back and base upholstered in graduated polyurethane/ Dacron Du Pont. Cushion in regenerated and regenerable polyester flakes. Removable fabric cover.

**Canapés monoblocs et composables, pouf et coussin**

Structure en bois. Rembourrage assise, dossier et base en polyuréthane à densité variable/ Dacron Du Pont. Coussin en flocons de polyester régénérés et régénérables. Revêtement déhoussable en tissu.

**Einteilige und zusammenstellbare Sofas, Hocker und Kissen**

Gestell aus Holz. Sitz-, Rücken- und Basispolsterung aus Polyurethan mit unterschiedlicher Dichte/ Dacron Du Pont. Kissen aus regenerierten und regenerierbaren Polyesterflocken. Abnehmbarer Bezug aus Stoff.

**Sofás monobloque y modulares, puf y cojín**

Estructura de madera. Asiento, respaldo y base de poliuretano a densidades diferenciadas/ Dacron Du Pont. Cojín de copos de poliéster regenerado y regenerable. Tapizado desenfundable de tejido.



1265/212

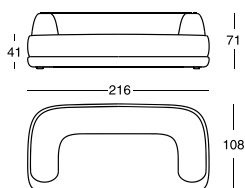

1265/302

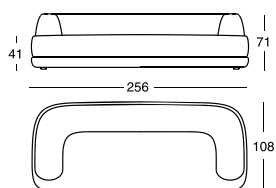

1265/300P

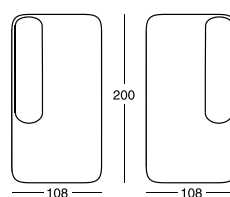

1265/AL1

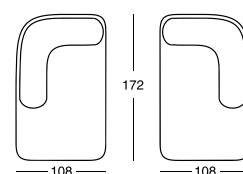

1265/201

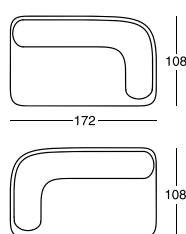

1265/ANG1

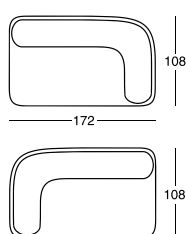

1265/PUF

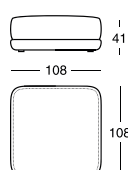

1265/50C

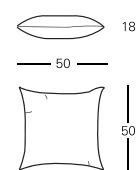

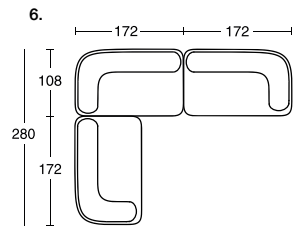
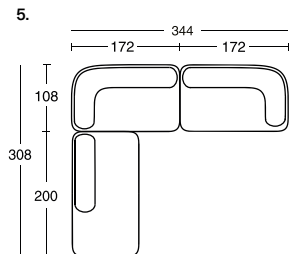
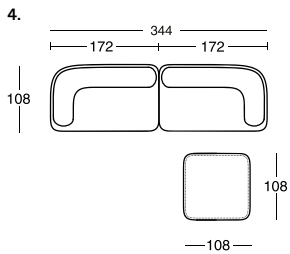
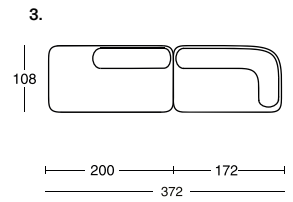
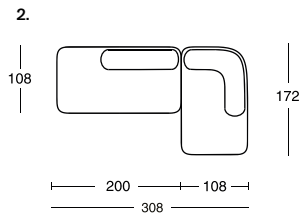
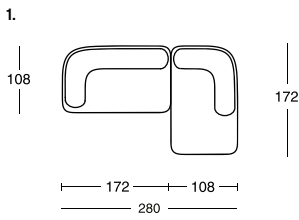





Design

Prospero Rasulo

2008

IN/OUT

**Poltrona e divano per esterni e interni**

Struttura interna in acciaio verniciato per esterni. Incordatura in filo di PVC con rinforzo interno di nylon colore marrone. A richiesta

è disponibile un cuscinetto di seduta imbottito in poliuretano/Dacron Du Pont.

**Armchair and sofa for outdoor and indoor**  
Steel internal structure painted for outdoor use. Weave in brown PVC thread with nylon internal reinforcement. Upon

request a small seat cushion upholstered with polyurethane/Dacron Du Pont is available.

**Fauteuil et canapé pour extérieurs et intérieurs**  
Structure interne en acier verni pour extérieurs. Tressage en fil de PVC avec renfort interne en nylon, couleur marron. Sur

1009/102

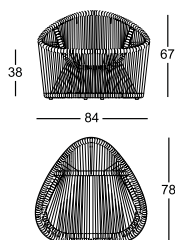

1009/302

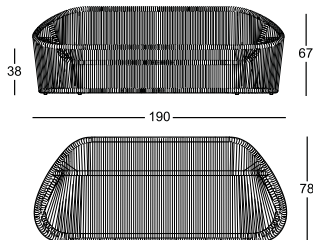

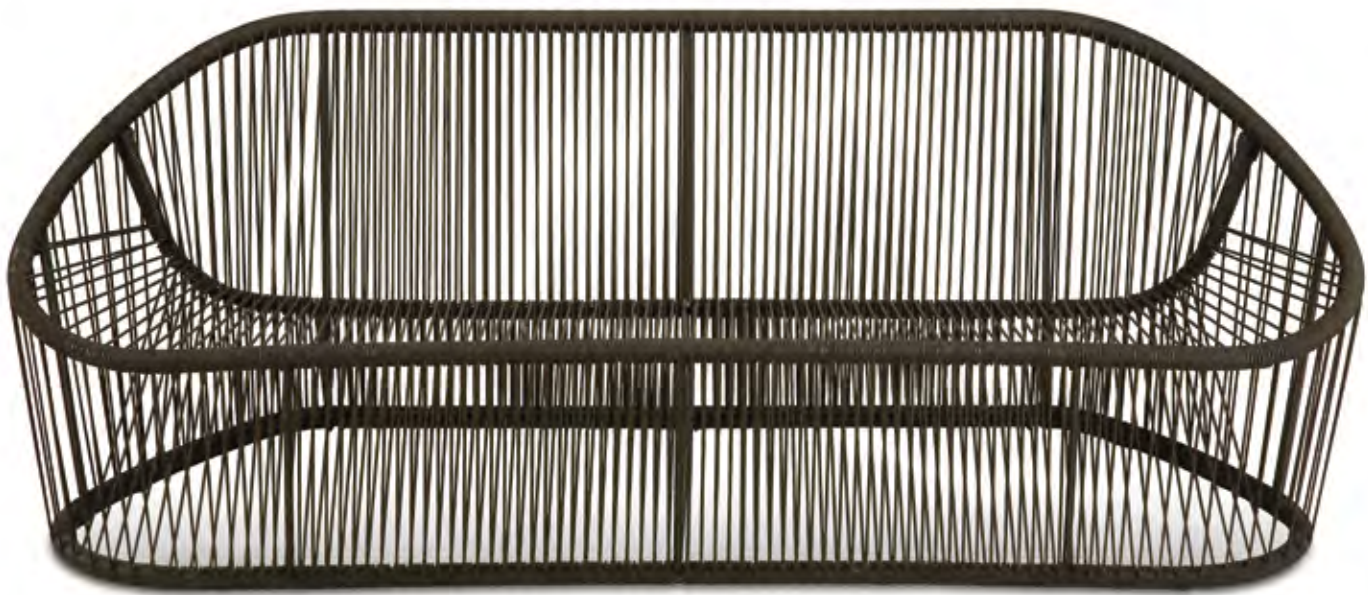

---

demande est disponible  
un coussinet du siege  
rembourré en polyuréthane/  
Dacron Du Pont.

**Sessel und Sofa für Innen  
und Freie**

Innere Struktur aus  
lackiertem Stahl fürs Freie.  
Geflecht aus PVC Draht  
mit innerer Verstärkung  
aus Nylon in der Farbe

braun. Auf Nachfrage ist ein  
gepolstertes Sitzkissen mit  
Polyurethan/Dacron Du Pont  
verfügbar.

**Sillón y sofá para  
exteriores y interiores**

Estructura interior de acero  
pintado para exteriores.  
Trenzado en hilo de PVC  
con refuerzo interno de  
nylon color marrón. Sobre

pedido es disponible un  
cojín pequeño de asiento  
acolchado de poliuretano/  
Dacron Du Pont.

# Flamingo <sup>1333</sup>



Design

Damian Williamson

2017

## Poltrona, divani monoblocco e componibili

Piedini in lega di alluminio lucidato, nichelsatinato colore naturale o nero, oppure verniciato colore nero. Struttura in acciaio. Molleggio su nastri elastici. Imbottitura in poliuretano/fibra poliestere termolegata. Cuscino seduta in poliuretano/fibra poliestere termolegata. Imbottitura cuscini schienale e poggiatesta in piuma d'oca. Rivestimento sfilabile in stoffa o in pelle.

## Armchair, monobloc and modular sofas.

Polished or black painted aluminum alloy feet, or with natural or black nickel-satin finish. Steel frame. Elastic strips suspension. Upholstery in polyurethane/heat-bound polyester fibre. Seat cushion upholstered with polyurethane/heat-bound polyester fibre. Back and lumbar cushions upholstered with goose feathers. Removable fabric or leather cover.

## Fauteuil et canapés monoblocs et composables

Pieds en alliage d'aluminium poli, ou nickel satiné, dans les couleurs naturel ou noir, ou verni noir. Structure en acier. Suspension sur sangles élastiques. Rembourrage en polyuréthane/fibre polyester liée à chaud. Coussins d'assise en polyuréthane/fibre polyester liée à chaud. Rembourrage en plume d'oie. Revêtement déhoussable en tissu ou en cuir.

## Sessel, einteilige und zusammenstellbare Sofas

Füße aus polierter oder schwarz-lackierter Aluminiumlegierung, oder mit naturfarbenen- oder schwarz-vernicheltem und mattiertem Finish. Gestell aus Stahl. Federung auf elastischen Gurten. Polsterung aus Polyurethan/wärmegebundener Polyesterfaser. Sitzkissen aus Polyurethan/wärmegebundener Polyesterfaser. Polsterung der Rücken- und Nierenkissen aus Gänsefedern. Abnehmbarer Bezug aus Stoff oder Leder.

## Butaca, sofás monobloque y modulares

Patas de aleación de aluminio pulido, o niquelado mate en los acabados natural o negro, o pintado negro. Estructura de acero. Suspensión sobre cintas elásticas. Acolchado de poliuretano/fibra poliéster termounida. Cojín asiento de poliuretano/fibra poliéster termounida. Cojín de respaldo y lumbar acolchados con pluma de ganso. Tapizado desenfundable de tejido o de piel.

Piedini/Feet/Pieds/Füße/Patas





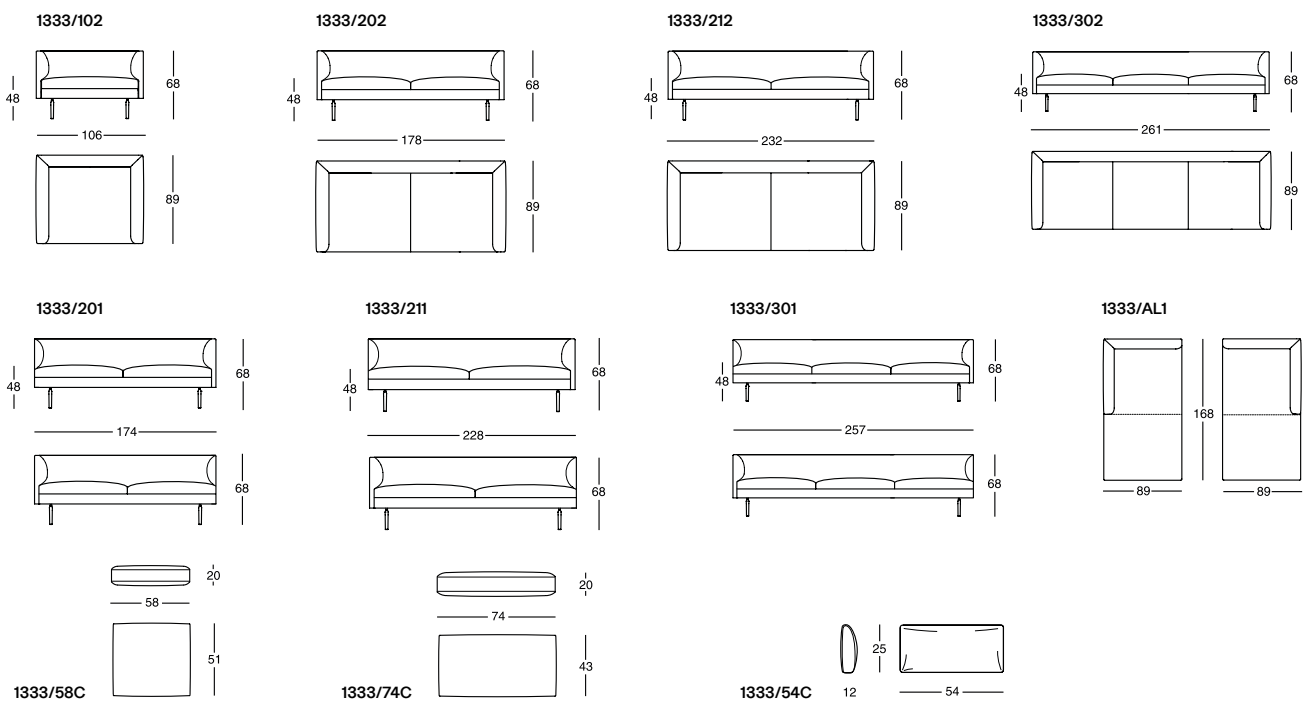

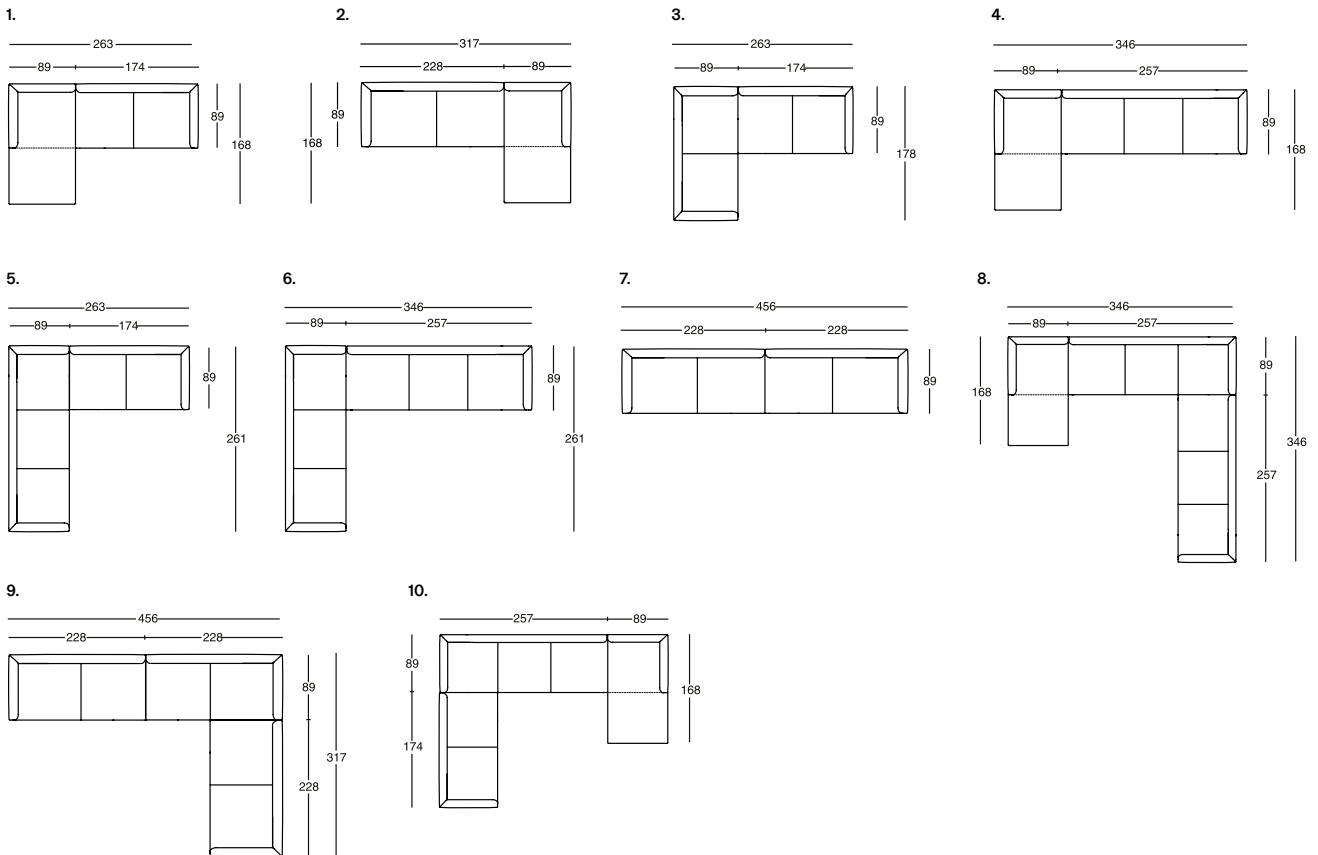



# Kilt<sup>1242</sup>

# Kilt 84<sup>1243</sup>



Design

Emaf Progetti

2006

**Poltrona, divani monoblocco, componibili, pouf**

Struttura in acciaio. Molleggio su nastri elastici. Imbottitura in poliuretano/fibra poliestere termolegata. Rivestimento con cuscino seduta trapuntato, sfilabile, in stoffa o in pelle.

**Armchair, monobloc, modular sofas, pouf**  
Steel frame. Elastic strips suspension. Upholstery in polyurethane/heat-bound polyester fibre. Removable fabric or leather cover with quilted seat cushion.

**Fauteuil, canapés monoblocs, composables, pouf**  
Structure en acier. Suspensions sur sangles élastiques. Rembourrage en polyuréthane/fibre polyester liée à chaud. Revêtement avec coussin assise surpiqué, déhoussable en tissu ou en cuir.

**Sessel, einteilige, zusammenstellbare Sofas, Hocker**  
Stahlgestell. Federung mit elastischen Gurten. Polsterung aus Polyhurethan/wärmegebundener Polyesterfaser. Abnehmbarer Bezug mit Steppung über den Sitzpolstern aus Stoff oder Leder.

**Butaca, sofás monobloque, modulares, puf**  
Estructura de acero. Asiento sobre cintas elásticas. Acolchado de poliuretano/fibra poliéster termounida. Tapizado con cojín del asiento respuntado, desenfundable, de tejido o de piel.



1242/202

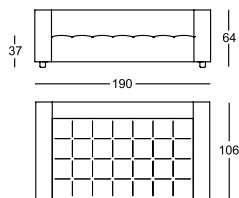

1242/212

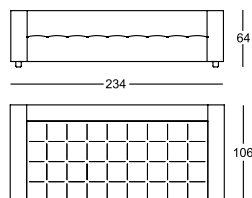

1242/302

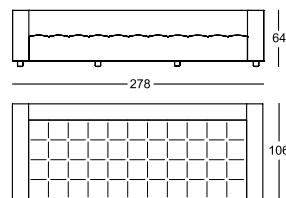

1242/301P

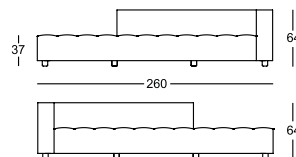

1242/PUF

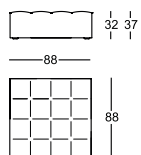

1242/201

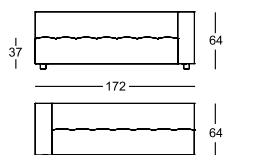

1242/211

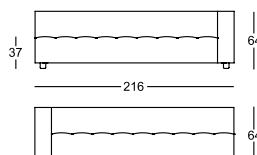

1242/301

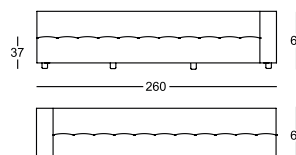

1242/ALPIS-ALPID

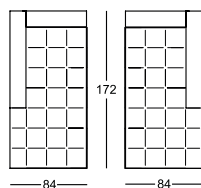

1242/ALIS-ALID

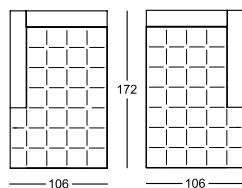



1243/102

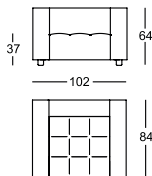

1243/202

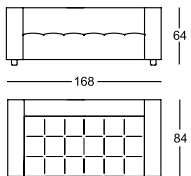

1243/212

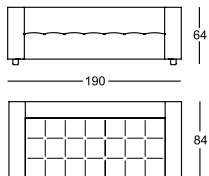

1243/302

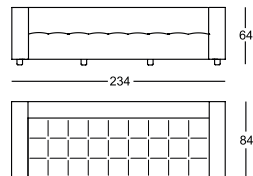

1243/201

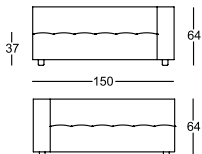

1243/211

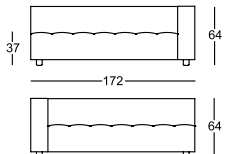

1243/301

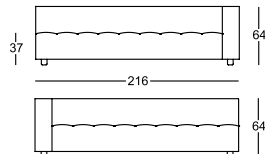

1243/301P

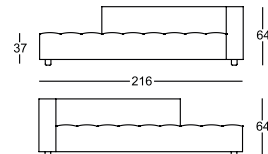

1243/ALPIS-ALPID

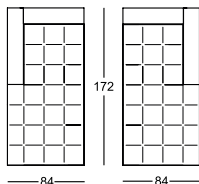

1243/ALIS-ALID

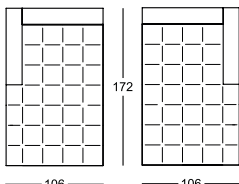

1244/C

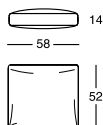

1245/C

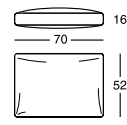

1.

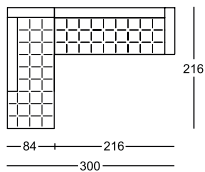

2.

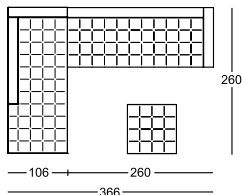

3.

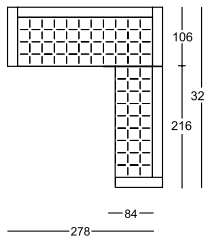

4.

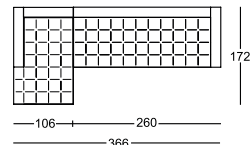

5.

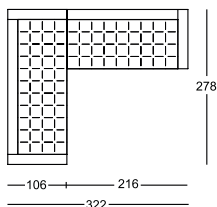

6.

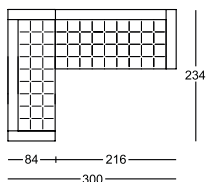

7.

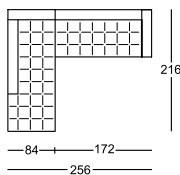

8.

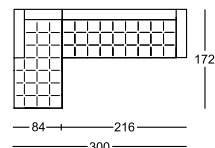

9.

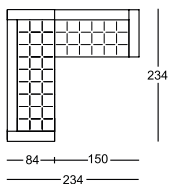

10.

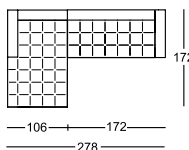

11.

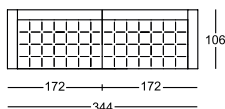

12.

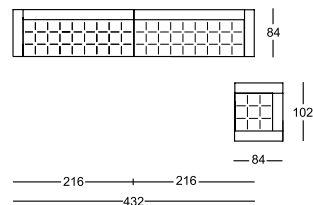

13.

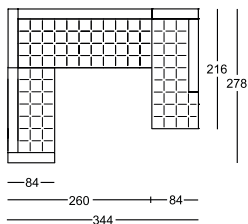

14.

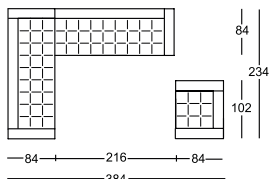

15.

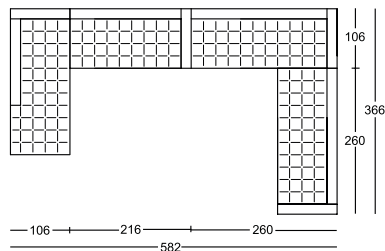



Design

De Pas, D'Urbino, Lomazzi

1982-2019

**Divani monoblocco, componibili e pouf**

Piedini in lega di alluminio nichelsatinato colore naturale o nero. Struttura in acciaio. Molleggio su nastri elastici. Cuscino seduta unico in poliuretano/fibra poliestere termolegata; cuscini schienale e braccioli in fibra poliestere. Rivestimento sfilabile in stoffa o in pelle.

**Monobloc, modular sofas and pouf**

Aluminum alloy feet, with natural or black nickel-satin finish. Steel frame. Elastic strips suspension. Single seat cushion in polyurethane/heat-bound polyester fibre; backrest cushions and armrests in polyester fibre. Removable fabric or leather cover.

**Canapés monoblocs, composables et pouf**

Pieds en alliage d'aluminium nickel satiné dans les finitions naturelle ou noire. Structure en acier. Suspension sur sangles élastiques. Coussin siège d'une seule pièce en polyuréthane/fibre de polyester liée à chaud; coussins dossier et accoudoirs fibre de polyester. Revêtement déhoussable en tissu ou en cuir.

**Einteilige, zusammenstellbare Sofas und Hocker**

Füße aus Alu-Legierung, mit naturfarben- oder schwarz- vernickeltem und mattiertem Finish. Gestell aus Stahl. Federung mit elastischen Gurten. Einteilige Sitzpolsterung aus Polyurethan/wärmegebundener Polyesterfaser; Rückenkissen und Armlehnen aus Polyesterfaser. Abnehmbarer Bezug aus Stoff oder Leder.

**Sofás monobloque, modulares y púf**

Patas de aleación de aluminio niquelado mate en los acabados natural o negro. Estructura de acero. Asiento sobre cintas elásticas. Cojín de asiento único de poliuretano/fibra poliéster termounida; cojines de respaldo y apoyabrazos de fibra de poliéster. Tapizado desenfundable de tejido o de piel.

Piedini/Feet/Pieds/Füße/Patas







1039/212

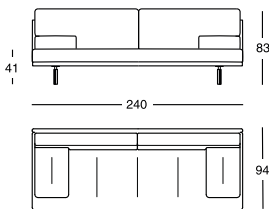

1039/302

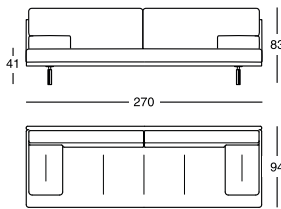

1039/PUF

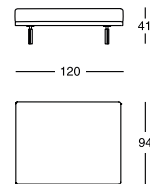

1039/211

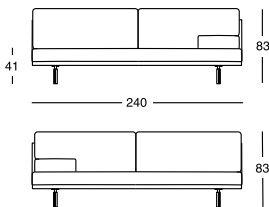

1039/301

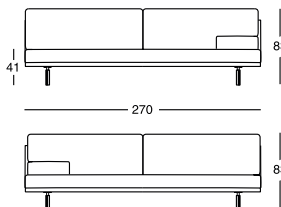

1039/AL1

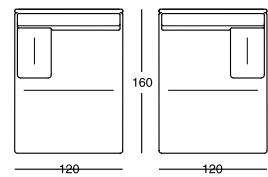

1.

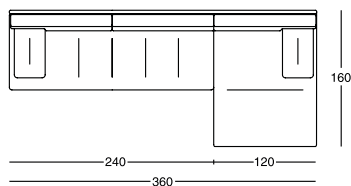

2.

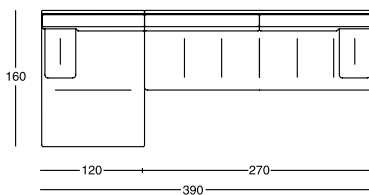

3.

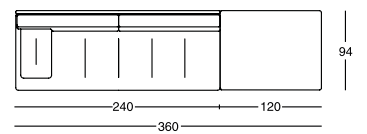

4.

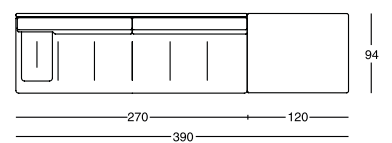



Design

Damian Williamson

2022

**Divani monoblocco, componibili rettilinei e curvi con bracciolo o vassoio, pouf**

Piedini in acciaio nichelsatinato lucido colore nero oppure verniciato colore grafite. Struttura in acciaio. Molleggio su nastri elastici. Cuscino seduta unico in poliuretano/fiocchi di poliestere rigenerato e rigenerabile. Cuscino schienale in piuma d'oca — materiale 100% vergine. Cuscino bracciolo in fiocchi di poliestere rigenerato e rigenerabile. Gli elementi terminali rettilinei e curvi possono essere dotati di cuscino bracciolo oppure essere attrezzati con un

vassoio in legno massello di frassino verniciato nero poro aperto opaco sulla base portante del divano. Rivestimento sfilabile in stoffa o in pelle. È disponibile un vassoio circolare Ø 45 cm in legno massello di frassino verniciato nero poro aperto opaco che può essere appoggiato liberamente sui cuscini di seduta. I pannelli perimetrali sono rivestiti nella stessa stoffa o pelle dei cuscini.

**Monobloc, straight and curved modular sofas with armrest or tray, pouf**

Steel feet, with glossy black nickelsatin finish or varnished graphite. Steel frame. Elastic strips suspension. Single-piece seat cushion in polyurethane/regenerated and regenerable polyester flakes. Back cushion in 100% new goose feathers. Armrest cushion in regenerated and regenerable polyester flakes. The straight and curved end-sofas can be equipped with an armrest cushion or with a tray, made of solid matt black painted ash with open pore, placed on the supporting base of the sofa. Removable fabric or leather cover. One

round-shaped tray, diameter 45 cm, made of solid matt black painted ash with open pore, is available and can be placed as desired on the seat cushions. The side panels are covered in the same fabric or leather as the cushions.

**Canapés monoblocs, composables rectilignes et incurvés avec accoudoir ou plateau, pouf**

Pieds en acier nickel-satiné poli noir ou verni graphite. Structure en acier. Suspension sur sangles élastiques. Coussin assise dans une seule pièce en polyuréthane à densité variable/flocons de polyester régénérés et régénérables. Coussin dossier en plume d'oie - matériel 100% vierge. Coussin accoudoir en flocons de polyester régénérés et régénérables. Les éléments terminaux droits et courbes peuvent être équipés d'un coussin d'accoudoir ou être équipés



d'un plateau en bois de frêne massif verni noir mat à pores ouverts sur la base de support du canapé. Revêtement déhoussable en tissu ou en cuir. Un plateau circulaire Ø 45 cm est disponible en bois de frêne massif verni noir mat à pores ouverts qui peut être placé librement sur les coussins d'assise. Les panneaux périmétriques sont recouverts du même tissu ou du même cuir que les coussins.

**Einteilige, zusammenstellbare geradlinige oder gebogene Sofas mit Armlehne oder Tablett, Hocker**

Stahl-Füße, in der schwarz vernickelten und mattierten Ausführung oder Graphit lackiert. Stahl-Gestell. Federung mit elastischen Gurten. Einteiliges Sitzkissen aus Polyurethan mit unterschiedlicher Dichte/regenerierten und regenerierbaren Polyesterflocken. Rückenkissen aus 100% reinen Gänsefedern. Armlehnen Kissen aus regenerierten und regenerierbaren Polyesterflocken. Die

geradlinigen und gebogenen Endelemente können mit einem Armlehnen Kissen oder einem Tablett, aus massivem Eschenholz, matt offenporig schwarz lackiert, auf dem Traggestell des Sofas ausgestattet werden. Abnehmbarer Bezug aus Stoff oder Leder. Ein rundes Tablett, Durchmesser 45 cm., aus massivem Eschenholz, matt offenporig schwarz lackiert, ist lieferbar und kann wunschgemäß auf dem Sitzkissen gelegt werden. Die Seitenpaneele werden mit dem gleichen Stoff oder Leder wie die Kissen bezogen.

**Sofás monobloque, modulares rectilíneos y curvos con apoyabrazos o bandeja, puf**

Patas de acero niquelado brillante negro, o pintado color grafito. Estructura de acero. Suspensión sobre cintas elásticas. Cojín de asiento único de poliuretano a densidades diferenciadas/ copos de poliéster regenerado y regenerable. Cojín de respaldo de pluma de ganso - material 100% virgen. Cojín apoyabrazo de copos de poliéster regenerado y regenerable. Los elementos terminales rectilíneos y curvos pueden equiparse con un cojín apoyabrazos o

equiparse con una bandeja en madera maciza de fresno pintada de negro poro abierto mate colocada en la estructura del sofá. Tapizado desenfundable de tejido o de piel. Una bandeja redonda de Ø 45 cm está disponible en madera maciza de fresno pintada mate de poro abierto negro que se puede colocar libremente sobre los cojines de asiento. Los paneles perimetrales están tapizados en el mismo tejido o piel de los cojines.

Piedini/Feeet/Pieds/Füße/Patas





1345/202

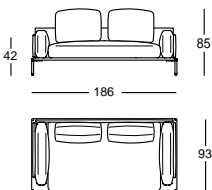

1345/212

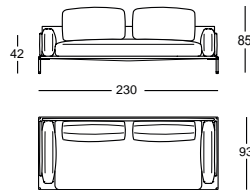

1345/302

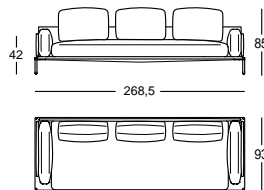

1345/POUF

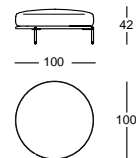

1345/201

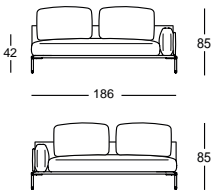

1345/211

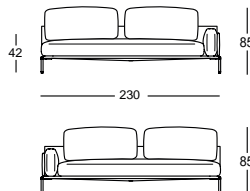

1345/301

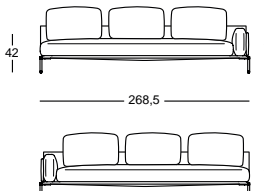

1345/301T

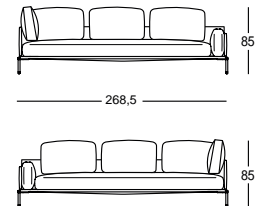

1345/AL1

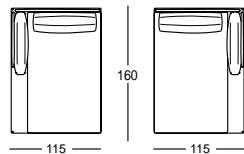

1345/300PANG

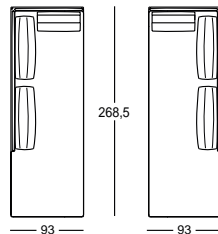

1345/211V

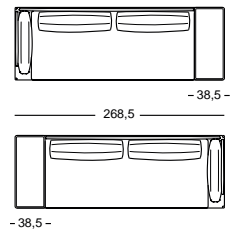

1345/210V

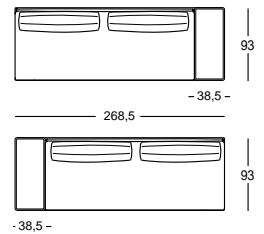

1345/201C

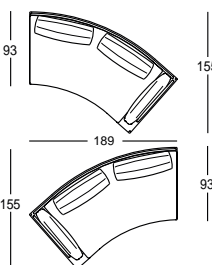

1345/200CV

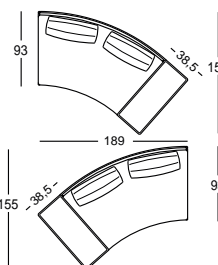

1345/VD45

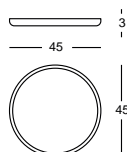



1.

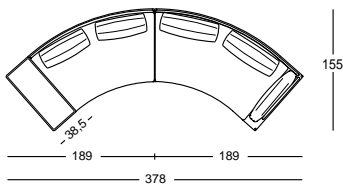

2.

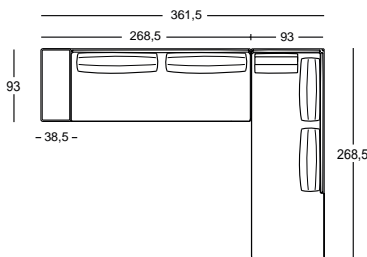

3.

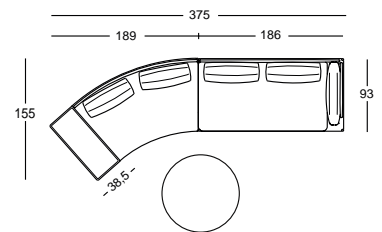

4.

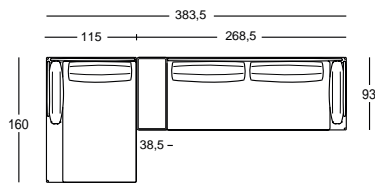

5.

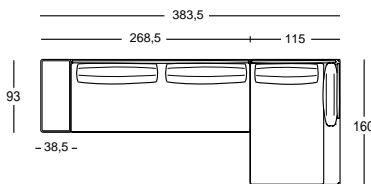

6.

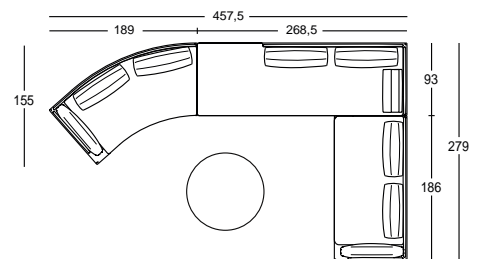

7.

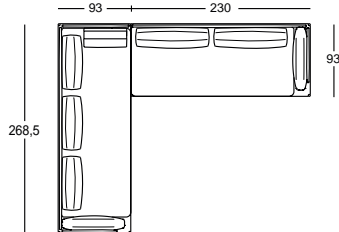

8.

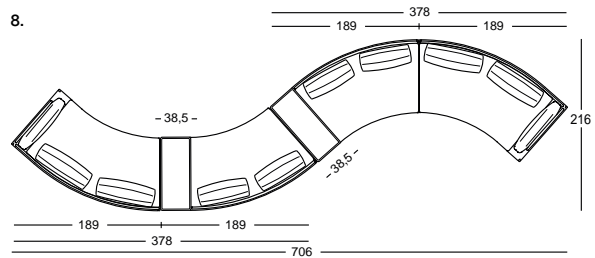

9.

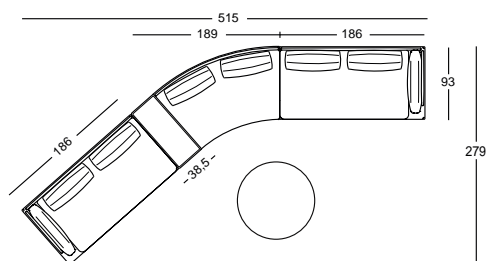

10.

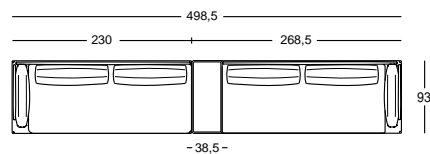

# Onda 1030



Design

De Pas, D'Urbino, Lomazzi

1985

## Poltrona e divani monoblocco

Struttura portante in tubo di acciaio inox. Imbottitura in poliuretano/fibra poliestere termolegata. Rivestimento sfilabile in stoffa o in pelle. La sfoderabilità è resa possibile solamente da personale specializzato.

## Armchair and monobloc sofas

Stainless steel tubular frame. Upholstery in polyurethane/heat-bound polyester fibre. Removable fabric or leather cover. The cover can be removed only by skilled staff.

## Fauteuil et canapés monoblocs

Structure portante en tube d'acier inox. Rembourrage en polyuréthane fibre polyester liée à chaud. Revêtement déhoussable en tissu ou en cuir. Il est possible de dehousser le canapé seulement par un personnel spécialisé.

## Sessel und einteilige Sofas

Tragendes Gestell aus Inox-Stahlrohr. Polsterung aus Polyhurethan/wärmegebundener Polyesterfaser. Abnehmbarer Bezug aus Stoff oder Leder. Der Bezug kann nur vom Fachpersonal abgenommen werden.

## Butaca y sofás monobloque

Estructura portante de tubo de acero inox. Acolchado de poliuretano/fibra poliéster termounida. Tapizado desenfundable de tejido o de piel. Es posible quitar la funda solo de personal especializado.

1030/102

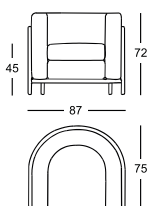

1030/202

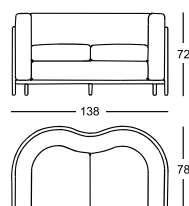

1030/302

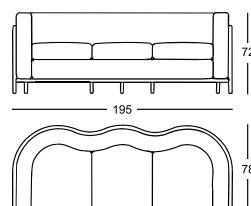



Design

Emaf Progetti

2011

IN/OUT

**Divani monoblocco e pouf per esterni**

Struttura portante in acciaio verniciato per esterni, colore bianco o nero. Molleggio su nastri elastici. Cuscini seduta, schienale e bracciolo in poliuretano reticolato a cellula aperta/Paineira, fibra vegetale idrorepellente. Rivestimento sfilabile in tessuto Talasso.

**Monobloc sofas and pouf for outdoor use**

Supporting frame in painted steel for outdoor use in the shade of white or black. Elastic strips suspension. Seat, back and armrest cushion in open cell reticulated polyether/Paineira, water-repellent vegetal fibre. Removable cover in fabric Talasso.

**Canapés monoblocs et pouf pour extérieur**

Structure portante en acier verni pour extérieurs, couleur blanc ou noir. Suspension sur sangles élastiques. Coussins d'assise, dossier et accoudoir en polyéther réticulé à cellule ouverte/Paineira, fibre végétale hydrofuge. Revêtement déhoussable en tissu Talasso.

**Einteilige Sofas und Hocker fürs Freie**

Tragendes Gestell mit Lackierung fürs Freie, in den Farben weiß oder schwarz. Federung auf elastischen Gurten. Sitzkissen, Rücken und Armlehne aus vernetztem Polyether mit offenen Zellen/Paineira, Pflanzenfaser, wasserabweisend. Abnehmbarer Bezug aus Stoff Talasso.

**Sofás monobloque y puf para exteriores**

Estructura portante de acero barnizada para exteriores color blanco o negro. Suspensión sobre cintas elásticas. Cojines de asiento, respaldo y apoyabrazo de poliéter reticulado con célula abierta/Paineira, fibra vegetal hidrorrepelente. Tapizado desenfundable de tejido Talasso.

Struttura/Frame/Structure/Gestell/Estructura



1034/202

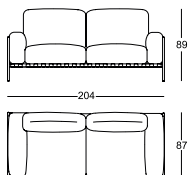

1034/212

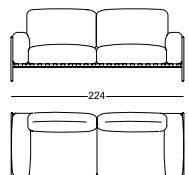

1034/302

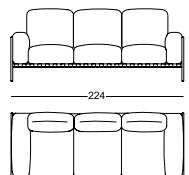

1034/312

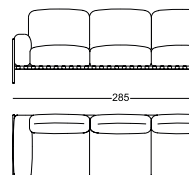

1034/402

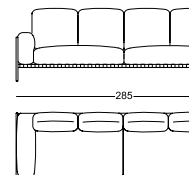

1034/PUF

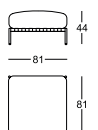

# Pianoalto <sup>1272</sup>

# Pianoalto 96 <sup>1273</sup>



Design

Ludovica+Roberto Palomba

2012

**Divani monoblocco, componibili, pouf**

Piedini in acciaio verniciati colore grafite. Struttura in legno. Molleggio su nastri elastici. Imbottitura sedile in poliuretano/Dacron Du Pont con inserto trapuntato in piuma d'oca. Imbottitura schienale e braccioli in poliuretano/Dacron Du Pont con inserto trapuntato in piuma d'oca e fiocchi di fibra poliestere. Imbottitura cuscini schienale in poliuretano/Dacron Du Pont o in piuma d'oca. Rivestimento sfilabile in stoffa o in pelle.

**Monobloc and modular sofas, pouf**

Graphite painted steel feet. Wooden frame. Elastic strips suspension. Seat upholstered in polyurethane/Dacron Du Pont with quilted insert of goose feathers. Backrest and armrests upholstered in polyurethane/Dacron Du Pont with quilted insert of goose feathers and polyester fibre flakes. Back cushions upholstered in polyurethane/Dacron Du Pont or in goose feathers. Removable cover in fabric or leather.

**Canapés monoblocs, composables, pouf**

Pieds en acier verni graphite. Structure en bois. Suspension sur sangles élastiques. Rembourrage de l'assise en polyuréthane / Dacron Du Pont avec insertion matelassé en plume d'oie. Rembourrage du dossier et des accoudoirs en polyuréthane/Dacron Du Pont avec insertion matelassé en plume d'oie et flocons de fibre polyester. Rembourrage des coussins du dossier en polyuréthane/Dacron Du Pont ou en plume d'oie. Revêtement déhoussable en tissu ou en cuir.

**Einteilige, zusammenstellbare Sofas, Hocker**

Füße aus graphitfarben lackiertem Stahl. Gestell aus Holz. Federung auf elastischen Gurten. Sitzpolsterung aus Polyurethan/Dacron Du Pont mit Steppeinsatz aus Gänsefedern. Polsterung von Arm- Rückenlehne aus Polyurethan/ Dacron Du Pont mit Steppeinsatz aus Gänsefedern und Flocken aus Polyesterfasern. Polsterung der Rückenkissen aus Polyurethan/Dacron Du Pont oder aus Gänsefedern. Abnehmbarer Bezug aus Stoff oder Leder.

**Sofás monobloques, modulares, pouf**

Pies de acero lacados en grafite. Estructura de madera. Suspensión con cintas elásticas. Asiento acolchado de poliuretano/Dacron Du Pont con inserción de pluma de ganso. Respaldo y brazos acolchados de poliuretano/Dacron Du Pont con inserción de pluma de ganso y copos de fibra de poliéster. Cojines de respaldo acolchados de poliuretano/Dacron Du Pont o pluma de ganso. Tapizado desenfundable de tejido o piel.





1272/302

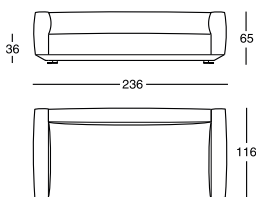

1272/201

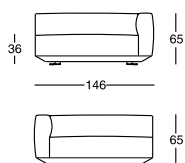

1272/301

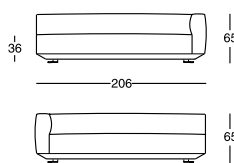

1272/200

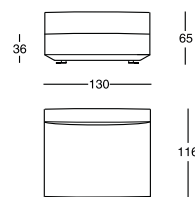

1272/300P

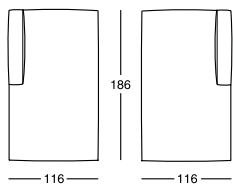

1272/ALIS-AL1D

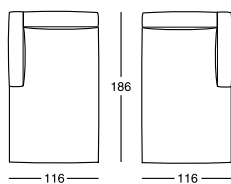

1272/245

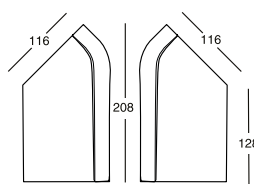

1272/245P

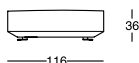
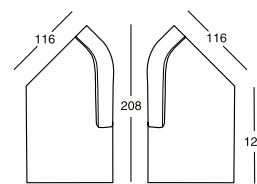

1272/PUF

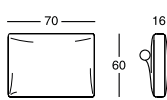

1272/70CR



1272/52C

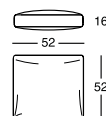

1272/70C

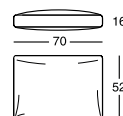



1273/212

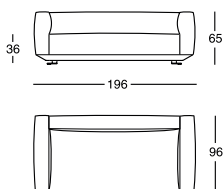

1273/302

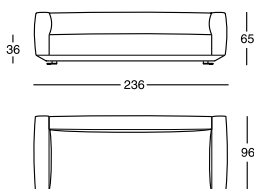

1273/201

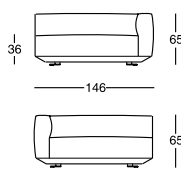

1273/301

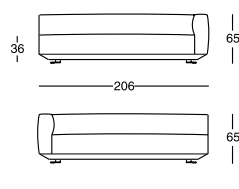

1273/300P

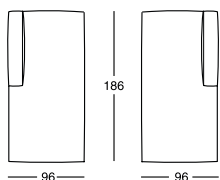

1273/ALIS-ALID

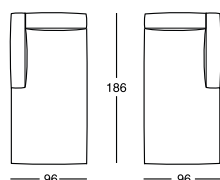

1273/200

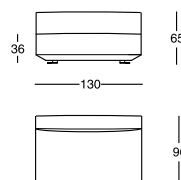

1272/PUF

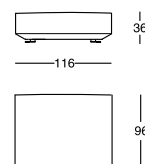

1273/52C

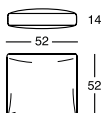

1273/70C

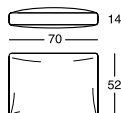



1.

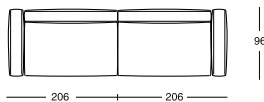

2.

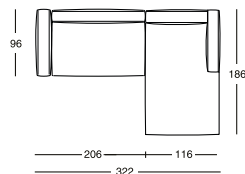

3.

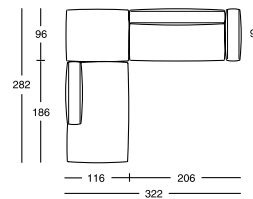

4.

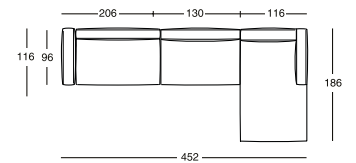

5.

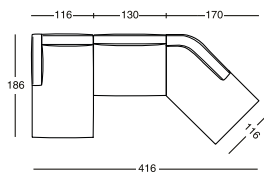

6.

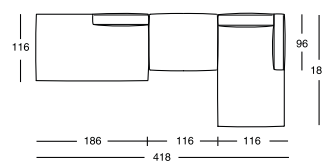

7.

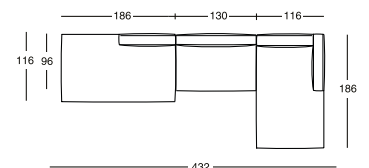

8.

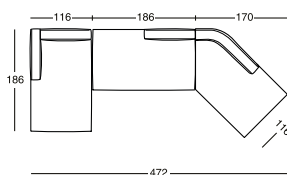

9.

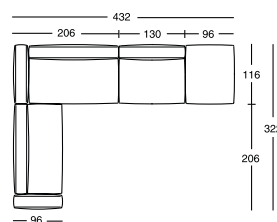

10.

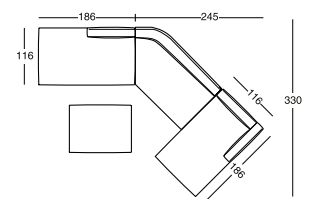



Design

Damian Williamson

2019

**Divani monoblocco e componibili**

Base in legno rivestita nello stesso tessuto o pelle del divano. Struttura in legno. Molleggio su nastri elastici. Imbottitura schienale e sedile in poliuretano/fibra poliestere termolegata. Cuscino schienale in piuma d'oca - materiale 100% vergine. Cuscino a rullo in poliuretano/fibra poliestere termolegata.

Rivestimento con cuscino seduta trapuntato, sfilabile in stoffa o in pelle. A richiesta, per i divani monoblocco, è disponibile la versione con tutti gli schienali alti.

**Monobloc and modular sofas**

Wooden base covered with the same fabric or leather of the sofa. Wooden frame. Elastic strips suspension. Backrest and seat upholstered with polyurethane/heat-bound polyester fibre. Backrest cushion in 100% new goose feathers. Roll-shaped cushion in polyurethane/heat-bound polyester fibre.

Removable fabric or leather cover with quilted seat cushion. Upon request, only for the monobloc sofas, the version with all higher backrests is available.

**Canapés monoblocs et composables**

Embasement en bois revêtu dans le même tissu ou cuir du canapé. Structure en bois. Suspension sur sangles élastiques. Rembourrage du dossier et du siège en polyuréthane / fibre de polyester liée à chaud. Coussin dossier en plume d'oie - matériel 100% vierge. Coussin cale-reins en polyuréthane/fibre polyester



liée à chaud. Revêtement avec coussin siège surpiqué, déhoussable en tissu ou en cuir. Sur demande, pour les canapés monoblocs, il est disponible une version avec tous les dossiers hauts.

**Einteilige und zusammenstellbare Sofas**  
Holzsockel mit dem gleichen Stoff oder Leder Bezug des Sofas. Holzgestell. Federung mit elastischen Gurten. Polsterung der Rückenlehne und Sitz aus Polyurethan/ wärmegebundener Polyesterfaser. Rückenkissen mit 100% reinen Gänsefedern. Nierenrolle-Kissen

aus Polyurethan/ wärmegebundener Polyesterfaser. Abnehmbarer Bezug mit Steppung über den Sitzpolstern aus Stoff oder Leder. Auf Nachfrage, nur für die einteilige Sofas, ist die Ausführung mit allen höhen Rückenlehnen verfügbar.

**Sofás monobloque y modulares**  
Base en madera tapizada con el mismo tejido o piel del sofá. Estructura en madera. Suspensión sobre cintas elásticas. Acolchado del respaldo y del asiento en poliuretano/fibra poliéster termounida. Cojín de respaldo en pluma de ganso, material 100% virgen. Cojín lumbar en poliuretano/

fibra poliéster termounida. Tapizado con cojín de asiento respunteado, desenfundable de tejido o de piel. Sobre pedido, para los sofás monobloque, está disponible la versión con los respaldos altos.



1247/212DX

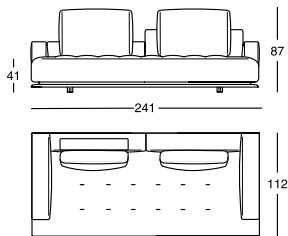

1247/212SX

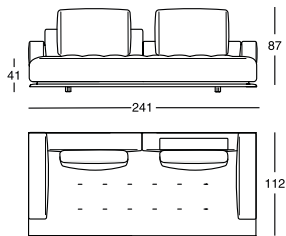

1247/302DX

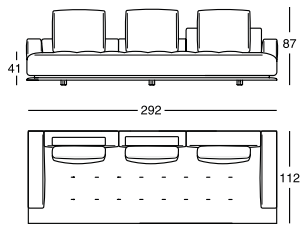

1247/302SX

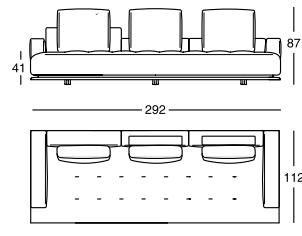

1247/301DANG

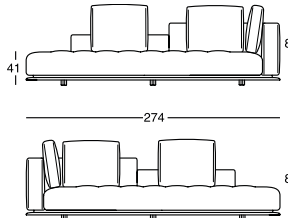

1247/211

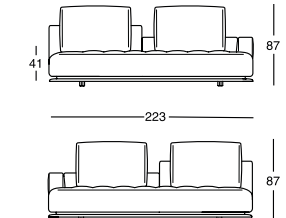

1247/301

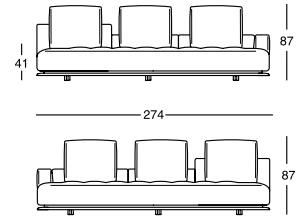

1247/301T

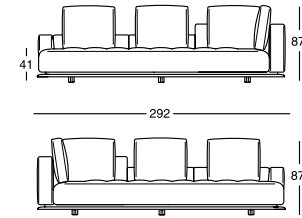

1247/ALP1

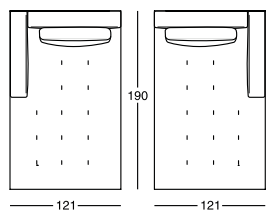

1247/AL1

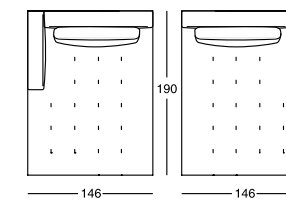



1.

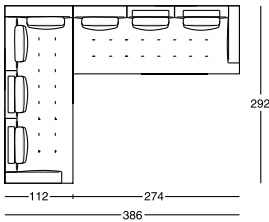

2.

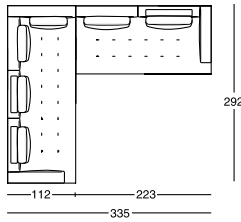

3.

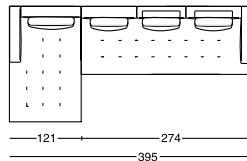

4.

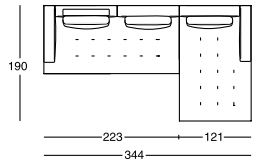

5.

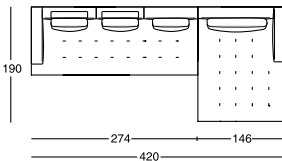

6.

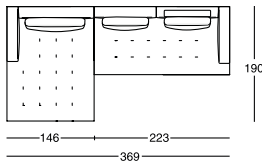

7.

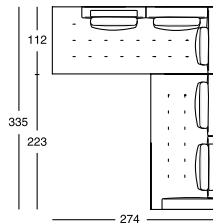

8.

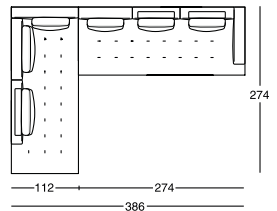

9.

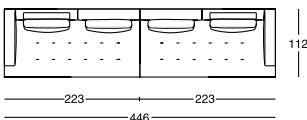

10.

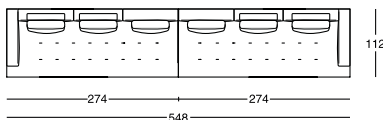

# Throw-Away<sup>1150</sup>



Design

Willie Landels

1965

**Poltrona, divani e pouf**  
Struttura in poliuretano espanso. Rivestimento sfilabile in stoffa o in pelle.

**Armchair, sofas and pouf**  
Expanded polyurethane frame. Removable cover in fabric or leather.

**Fauteuil, canapés et pouf**  
Structure en polyurethane expansé. Revêtement déhoussable en tissu ou en cuir.

**Sessel, Sofas und Hocker**  
Gestell aus Polyurethan-Schaum. Abnehmbarer Bezug aus Stoff oder Leder.

**Butaca, sofas y puf**  
Estructura de poliuretano espanso. Tapizado desenfundable de tejido o de piel.

1150/102

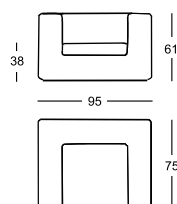

1150/202

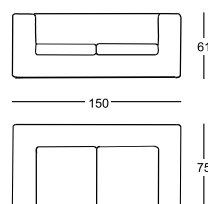

1150/302

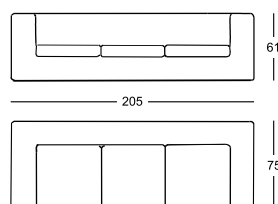

1150/PUF

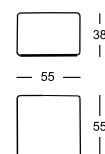







Design

Damian Williamson

2010-2015

**Poltrona, divani monoblocco, componibili, pouf, dormeuse e mensole**

Piedini in lega di alluminio lucidato, nichelsatinato colore naturale o nero, oppure verniciato nero. Struttura in acciaio. Molleggio su nastri elastici. Imbottitura in poliuretano/ fibra poliestere termolegata. Cuscini seduta, schienale e bracciolo in piuma d'oca. Rivestimento sfilabile in stoffa o in pelle. Le poltrone allungate senza bracciolo e i divani terminali sono predisposti per l'attacco

di una mensola in legno massello di rovere verniciato colore naturale o tinto grigio oppure in noce Canaletto verniciato colore naturale. Reggi-mensole in alluminio lucidato, nichelsatinato colore naturale o nero, o verniciato nero.

**Armchair, monobloc, modular sofas, pouf, day bed and shelves**

Aluminum alloy feet, either polished or with natural or black nickel-satin finish, or black painted. Steel frame. Elastic strips suspension. Upholstery in polyurethane/ heat-bound polyester fibre. Seat, back and armrest cushions upholstered with goose down. Removable fabric or leather cover. The lounge chairs without armrest and the end-sofas are fit to arrange a solid wood shelf, in natural or grey

painted oak or in natural painted Canaletto walnut. Shelf supports in polished, with natural or black nickel-satin finish, or black painted aluminum.

**Fauteuil, canapés monoblocs, composables, pouf, dormeuse et étagères**

Pieds en alliage d'aluminium poli, ou nickel-satiné, dans les couleurs naturel ou noir, ou verni noir. Piètement en acier. Suspension sur sangles élastiques. Rembourrage en polyuréthane/fibre polyester liée à chaud. Coussins d'assise, dossier et accoudoirs en plume d'oie. Revêtement déhoussable en tissu ou en cuir. Les fauteuils allongés sans accoudoir et



les canapés composables sont prédisposés pour l'accrochage d'une étagère en bois massif rouvre verni naturel ou teinté gris ou en noyer Canaletto verni naturel. Supports d'étagère en aluminium poli, ou nickel satiné, dans les couleurs naturel ou noir, ou verni noir.

**Sessel, einteilige, zusammenstellbare Sofas, Hocker, Liege und Stützfläche**

Füße aus polierter Aluminiumlegierung, oder mit naturfarben- oder schwarz vernickeltem und mattiertem Finish, oder schwarz lackiert. Gestell aus Stahl. Federung auf elastischen Gurten. Polsterung aus Polyurethan/wärmegebundener Polyesterfaser. Sitz-, Rücken und Armlehnen-Polsterung aus Gänsefedern. Abnehmbarer Bezug aus

Stoff oder Leder. Die Liegesessel ohne Armlehne und die zusammenstellbaren Sofas werden zur Befestigung einer Stützfläche ausgestattet, die entweder aus Massivholz in naturfarbener oder graugebeizter Eiche oder in naturfarben lackiertem Nussbaum Canaletto erhältlich ist. Stützfläche-Träger aus poliertem Aluminium, oder mit naturfarben- oder schwarz vernickeltem und mattiertem Finish, oder schwarz lackiert.

**Butaca, sofás monobloque, modulares, puf, butacas alargadas y repisas**

Patas de aleación de aluminio pulido o niquelado mate en los acabados natural o negro, o pintado negro. Estructura de acero. Suspensión sobre cintas elásticas. Acolchado de poliuretano/fibra poliéster termounida. Cojines asiento, respaldo y apoyabrazo de pluma de ganso. Tapizado desenfundable de tejido o de piel. Las butacas alargadas sin apoyabrazos y los sofás

modulares se preparan para fijar una repisa en madera maciza de roble pintado color natural o teñido gris, o en nogal Canaletto pintado color natural. Soportes de las repisas en aluminio pulido o niquelado mate en los acabados natural o negro, o pintado negro.

Piedini/Fee/Pieds/Füße/Patas



Reggi Mensole/Shelf supports/ Supports d'étagère/Stützfläche-Träger/ Soportes repisa



Rovere naturale/ Natural oakwood/ Rouvre naturel/ Naturfarbene Eiche/ Roble natural



Rovere tinta grigio/Grey varnished oak/ Rouvre teinté gris/Graugebeizte Eiche/ Roble teñido gris



Noce Canaletto/ Canaletto walnut/Noyer Canaletto/ Nussbaum Canaletto/Nogal Canaletto





1330/102

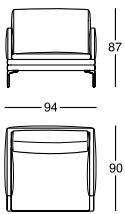

1330/202

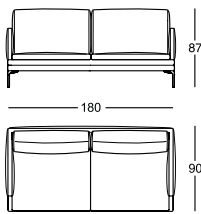

1330/212

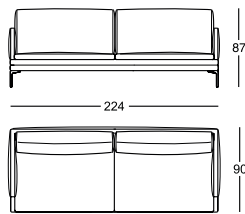

1330/302

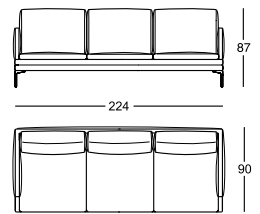

1330/312

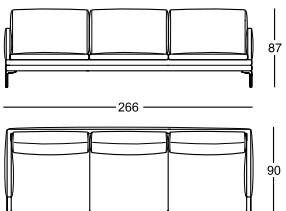

1330/201

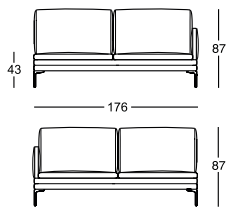

1330/211

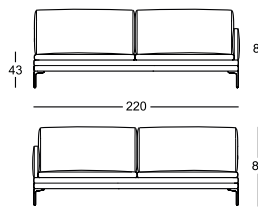

1330/301

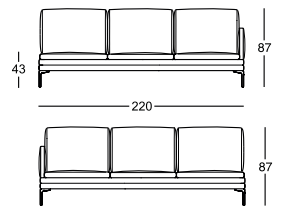

1330/M125

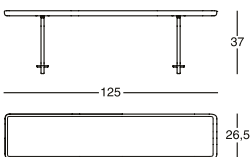

1330/M88

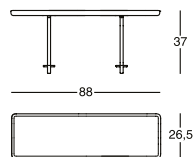

1330/M104

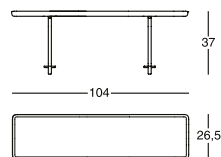



1330/311

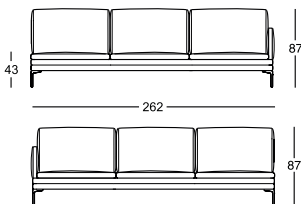

1330/301T

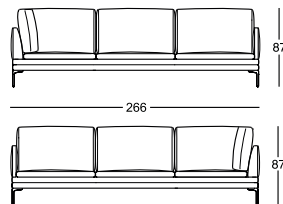

1330/AL1

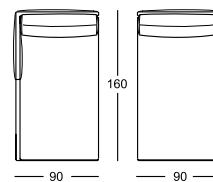

1330/DOR

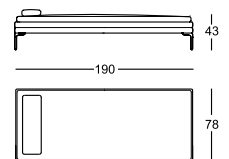

1330/AL2

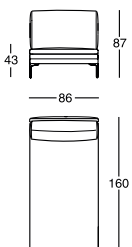

1330/AL3

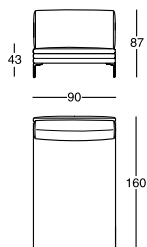

1330/AL4

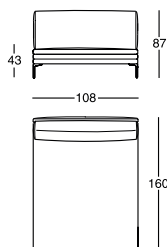

1330/210P

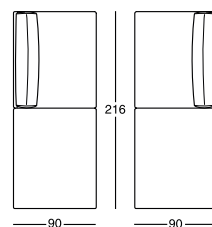

1330/210PANG

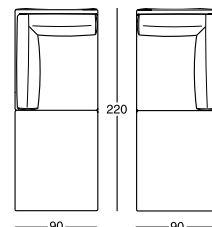

1330/211PT

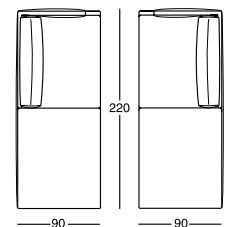

1330/PUF

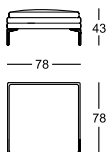

1330/BRA

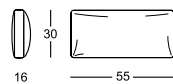





1.

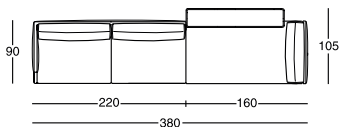

2.

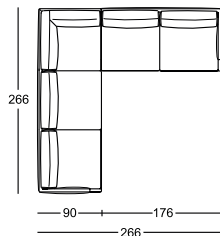

3.

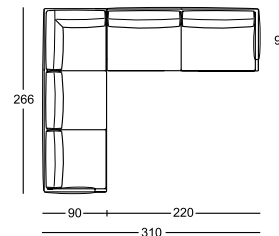

4.

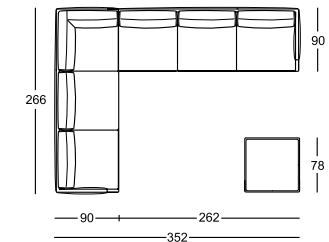

5.

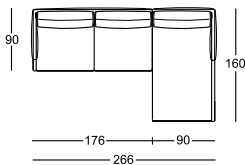

6.

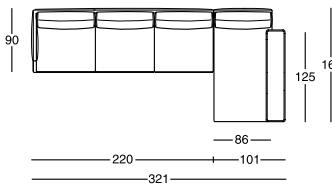

7.

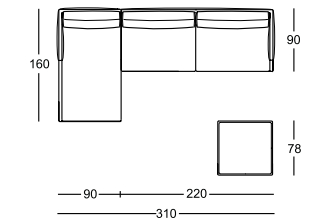

8.

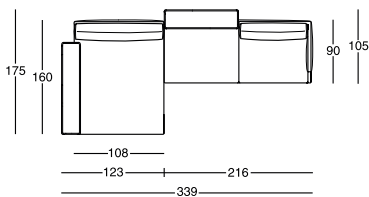

9.

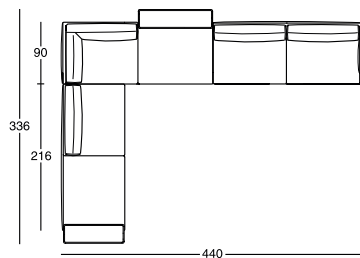

10.

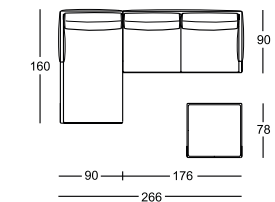



Design

Zaven

2022

#### Divani monoblocco

Struttura portante in acciaio verniciato colore nero o rosso opaco RAL 3004 dotata di nastri rigidi in poliestere colore antracite per il supporto dei cuscini. Cuscini seduta, schienale e bracciolo in poliuretano/ sfere di poliestere rigenerato e rigenerabile. Assemblaggio imbottiture privo di collanti. Rivestimento sfilabile in stoffa.

#### Monobloc sofas

Carrying frame in matt black or red RAL 3004 steel, complete of stiff polyester straps in the shade anthracite for the support of the cushions. Seat, back and armrest cushions in polyurethane/ regenerated and regenerable polyester balls. Paddings assembly without glues. Removable fabric cover.

#### Canapés monoblocs

Structure porteuse en acier verni noir ou rouge mat RAL 3004 avec rubans rigides en polyester anthracite pour le soutien des coussins. Coussins d'assise, dossier et accoudoir en polyuréthane/ boules de polyester régénéré et régénérable. Assemblage du rembourrage sans adhésifs. Revêtement déhoussable en tissu.

#### Einteilige Sofas

Traggestell aus matt schwarz oder rot RAL 3004 lackiertem Stahl mit steifen anthrazitfarbenen Polyesterbändern zur Unterstützung der Kissen. Sitz-Rücken und Armlehnen-Kissen aus Polyurethan/regenerierten und regenerierbaren Polyesterkugeln. Polstermontage ohne Klebstoffe. Abnehmbarer Bezug aus Stoff.

#### Sofás monobloque

Estructura portante en acero pintado en negro o rojo mate RAL 3004 con cintas rígidas de poliéster antracita para el soporte de los cojines. Cojines de asiento, respaldo y apoyabrazos en copos de poliuretano/bolas de poliéster regenerado y regenerable. Montaje de los acolchados sin cola. Tapizado desenfundable de tejido.

1045/202

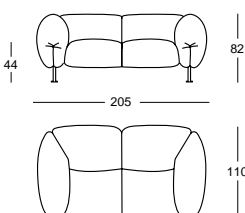

1045/212

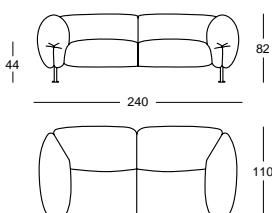

1045/302

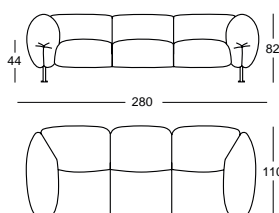

Struttura/Frame/Structure/Gestell/  
Estructura









Poltrone  
Armchairs  
Fauteuils  
Sessel  
Butacas

# Ardea CM <sup>882</sup>



Omaggio a

Carlo Mollino

1946

## Poltrona/Bergère

Base in legno massello di rovere naturale o tinto nero oppure in legno massello di noce Canaletto colore naturale; verniciatura con finitura a cera. Struttura in acciaio con molleggio su nastri elastici. Imbottitura in poliuretano/fibra poliestere termolegata. Rivestimento sfilabile in stoffa o pelle.

## Armchair/Bergère

Base in solid natural or black varnished oak, or in solid natural Canaletto walnut; wax-finished varnish. Steel frame, with elastic strips suspension. Upholstery in polyurethane/heat-bound polyester fibre. Removable cover in fabric or leather.

## Fauteuil/bergère

Socle en rouvre naturel massif ou teinté noir ou en noyer Canaletto massif, couleur naturelle; verni finition cirée. Structure en acier avec suspension sur sangles élastiques. Rembourrage en polyuréthane/fibre de polyester liée à chaud. Revêtement déhoussable en tissu ou en cuir.

## Sessel/Bergère

Sockel aus massiver naturfarbener oder schwarz lackierter Eiche, oder aus massivem naturfarbenem Nussbaum Canaletto; Lackierung mit Wachs-Endbehandlung. Gestell aus Stahl mit Federung auf elastischen Gurten. Polsterung aus Polyhurethan/wärmegebundener Polyesterfaser. Abnehmbarer Bezug aus Stoff oder Leder.

## Butaca de orejas

Base en madera maciza de roble natural o teñido negro o en madera maciza de nogal Canaletto color natural; pintura con acabado de cera. Estructura de acero con suspensión sobre cintas elásticas. Acolchado de poliuretano/fibra poliéster termounida. Tapizado desenfundable en tejido o piel.

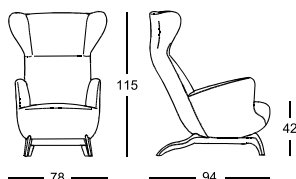

Rovere naturale/Natural oakwood/Rouvre naturel/Naturfarbene Eiche/Roble natural



Rovere tinto nero/Black varnished oak/Rouvre teinté noir/Schwarz-gebeizte Eiche/Roble teñido negro



Noce Canaletto/Canaletto walnut/Noyer Canaletto/Nussbaum Canaletto/Nogal Canaletto



# Arom <sup>872</sup>



Design

Noé Duchaufour Lawrance

2014

## Poltrona

Struttura in acciaio. Imbottitura in poliuretano/ fibra poliester termolegata con molleggio su nastri elastici. Rivestimento sfilabile in stoffa, Pied de poule o in pelle. La scocca esterna può essere rivestita anche in cuoio 95 in abbinamento a tessuto o pelle.

## Armchair

Steel frame. Upholstery with polyurethane/heat bound polyester fibre with elastic strips suspension. Removable cover in fabric, Pied de poule or leather. The exterior body can be covered with cowhide 95, combined with fabric or leather.

## Fauteuil

Structure en acier. Rembourrage en polyuréthane/fibre polyester liée à chaud avec suspension sur sangles élastiques. Revêtement déhoussable en tissu, Pied de poule ou en cuir. La coque extérieure peut également être revêtue en cuir sellier 95 en combinaison avec du tissu ou de cuir.

## Sessel

Gestell aus Stahl. Polsterung aus Polyurethan/wärmegebundener Polyesterfaser mit Federung auf elastischen Gurten. Abnehmbarer Bezug aus Stoff, aus Pied de poule oder Leder. Die Sitzschale kann außen mit Kernleder 95 in Kombination mit Stoff oder Leder bezogen werden.

## Butaca

Estructura de acero. Acolchado de poliuretano/ fibra poliéster termounida con suspensión sobre cintas elásticas. Tapizado desenfundable de tejido, Pied de poule o de piel. El bastidor exterior puede ser tapizado en cuero 95 en combinación con tejido o piel.

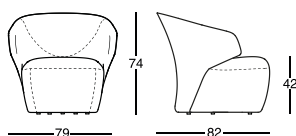

# Calla <sup>873</sup>



Design

Noé Duchaufour Lawrance

2010

## Poltroncina

Base su ruote o fissa con piedini. Struttura in acciaio. Imbottitura in poliuretano/ fibra poliestere termolegata con molleggio su nastri elastici. Rivestimento sfilabile in stoffa o in pelle. La scocca esterna può essere rivestita anche in cuoio 95 in abbinamento a tessuto o pelle. La poltroncina è disponibile in due differenti altezze da terra: alta 873/A con rotelle, bassa 873/B con piedini.

## Small armchair

Base on castors or fixed with feet. Steel frame. Upholstery with polyurethane/heat bound polyester fibre with elastic strips suspension. Removable fabric or leather cover. The exterior body can be covered with cowhide 95, combined with fabric or leather. The armchair is available in two different heights above ground level: high 873/A with castors, low 873/B with feet.

## Petit fauteuil

Base sur roulettes ou fixe avec pieds. Piètement en acier. Rembourrage de polyuréthane/fibre polyester liée à chaud avec suspension sur sangles élastiques. Revêtement déhoussable en tissu ou en cuir. La coque extérieure peut également être revêtue en cuir sellier 95 en combinaison avec du tissu ou de cuir. Le fauteuil est disponible en deux hauteurs du sol: haut 873/A avec roulettes, bas 873/B avec pieds.

## Kleiner Sessel

Sockel auf Rollen oder fest mit Füßen. Gestell aus Stahl. Polsterung aus Polyurethan/wärmegebundener Polyesterfaser mit Federung auf elastischen Gurten. Abnehmbarer Bezug aus Stoff oder Leder. Die Sitzschale kann außen mit Kernleder 95 in Kombination mit Stoff oder Leder bezogen werden. Der kleine Sessel ist in zwei verschiedenen Höhen ab Boden erhältlich: hoch 873/A mit Rollen, niedrig 873/B mit Füßen.

## Butaquita

Base sobre ruedas o fija con patas. Estructura de acero. Acolchado de poliuretano/ fibra poliéster termounida con suspensión sobre cintas elásticas. Tapizado desenfundable de tejido o de piel. El bastidor exterior puede ser tapizado en cuero 95 en combinación con tejido o piel. La butaquita está disponible en dos alturas diferentes: alto 873/A con ruedas, bajo 873/B con patas.

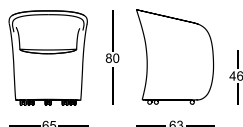

873/A

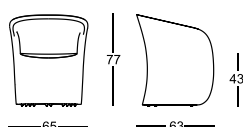

873/B

# Campiello+ 880



Design

De Pas, D'Urbino, Lomazzi

1984-2022

## Poltrona girevole

Schienale in multistrato di legno ricoperto in cuoio pigmentato 90 nei colori colore nero, antracite e fango o cuoio 95 nel colore gold. Sedile in poliuretano a quote differenziate/fiocchi di poliestere rigenerato e rigenerabile; poggiatesta e cuscino schienale in fiocchi di poliestere rigenerato e rigenerabile. Rivestimento sfilabile in stoffa. Solo il cuscino poggiatesta può essere richiesto in un colore diverso all'interno della stessa tipologia di tessuto.

## Swivel armchair

Backrest in plywood covered with cowhide 95 in the shade gold or with cowhide pigmentato 90 in the shades black, anthracite and mud. Seat with graduated polyurethane/regenerated and regenerable polyester flakes; lumbar and back cushion in regenerated and regenerable polyester flakes. Removable fabric cover. Only the lumbar cushion can be requested in a distinct colour within the same fabric.

## Fauteuil pivotant

Dossier en contreplaqué du bois recouvert en cuir sellier pigmentato 90 noir, anthracite, boue ou cuir sellier 95 couleur gold. Assise en polyuréthane à densité variable / flocons de polyester régénéré et régénérable; cale-reins et coussin de dossier en flocons de polyester régénéré et régénérable. Revêtement déhoussable en tissu. Le coussin cale-reins seulement peut être demandé dans le même type de tissu mais une couleur différente.

## Drehbarer Sessel

Rücken aus Sperrholz, bezogen mit Kernleder pigmentato 90 in den Farben schwarz, anthrazit und Schlamm, oder mit Kernleder 95 in der Farbe gold. Sitz aus Polyurethan in unterschiedlicher Dichte/ regenerierten und regenerierbaren Polyesterflocken; Nierenkissen und Rückenkissen aus regenerierten und regenerierbaren Polyesterflocken. Abnehmbarer Bezug aus Stoff. Nur das Nierenkissen kann innerhalb derselben Stoffart in einer anderen Farbe bestellt werden.

## Butaca giratoria

Respaldo en madera contrachapada recubierta en cuero pigmentato 90 en negro, antracita y barro o cuero 95 en color gold. Asiento en poliuretano a densidades diferenciadas/ copos de poliéster regenerado y regenerable; cojín respaldo y cojín lumbar regenerado y regenerable. Tapizado desenfundable de tejido. Sobre pedido se puede hacer el cojín de respaldo en un color diferente dentro del mismo tipo de tejido.

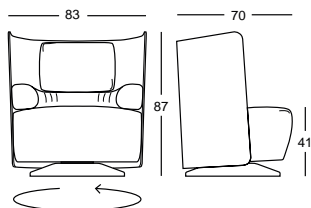

Schienale / Backrest / Dossier / Rücken / Respaldo



# Derby<sup>875</sup>



Design

Noé Duchaufour Lawrance

2009 - 2010

**Poltrona/bergère, pouf**

Poltrona con base girevole in acciaio o fissa con piedini e scocca esterna in poliuretano rigido rivestita in cuoio 95. Imbottitura scocca interna e pouf in poliuretano/fibra poliestere termolegata con molleggio su nastri elastici. Rivestimento sfilabile in stoffa o in pelle. Struttura pouf in acciaio.

**Armchair/bergère, pouf**

Armchair with steel base, swivel or fixed with feet and stiff polyurethane exterior body covered with cowhide 95. Upholstery of internal body and pouf in polyurethane/heat-bound polyester fibre with elastic strips suspension. Removable fabric or leather cover. Pouf steel frame.

**Fauteuil/Bergère, pouf**

Fauteuil avec base pivotante en acier ou fixée avec pieds et coque extérieure en polyuréthane rigide, revêtue en cuir sellier 95. Rembourrage de la coque intérieure et pouf en polyuréthane/fibre polyester liée à chaud avec suspension sur sangles élastiques. Revêtement déhoussable en tissu ou en cuir. Structure pouf en acier.

**Sessel/Bergère, Hocker**

Sessel mit Stahlsockel, drehbar oder fest mit Füßen und äußere Sitzschale aus steifem Polyurethan, mit Kernleder 95 bezogen. Innere Sitzschale und Hocker mit Polsterung aus Polyurethan/wärmegebundener Polyesterfaser mit Federung auf elastischen Gurten. Abnehmbarer Bezug aus Stoff oder Leder. Hocker-Gestell aus Stahl.

**Sillón/bergère, puf**

Sillón con base giratoria de acero o fija con pies y bastidor exterior de poliuretano tapizado de cuero 95. Acolchado del bastidor interior y del puf de poliuretano/fibra poliéster termounida con suspensión sobre cintas elásticas. Tapizado desenfundable de tejido o de piel. Estructura puf de acero.

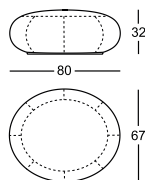
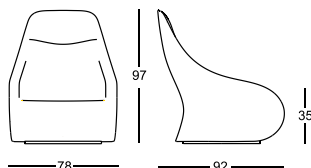





Design

Gabriele Mucchi

1935

#### Chaise longue

Struttura in acciaio cromato, o nichelsatinato colore naturale o nero, oppure verniciato nero. Molleggio su spirali di acciaio. Seduta regolabile su due posizioni. Imbottitura cuscino seduta e poggiatesta in poliuretano. Rivestimento cuscini e braccioli in pelle.

#### Lounge chair

Chromium-plated steel frame or with natural or black nickel-satin finish, or black painted. Suspension on steel springs. Adjustable seat in two positions. Cushion and headrest upholstered in polyurethane. Leather-covered cushions and armrests.

#### Chaise longue

Structure en acier chromé, nickel satiné, dans les finitions naturelle ou noire, ou en acier verni noir. Suspension à spirales d'acier. Assise réglable en deux positions. Coussin et appuie-tête en polyuréthane. Revêtement coussins et accoudoirs en cuir.

#### Chaiselongue

Gestell aus verchromtem oder schwarz-lackiertem Stahl, oder mit naturfarben- oder schwarz- vernickeltem und mattiertem Finish. Federung auf Stahlfedern. Sitzhöhe zweifach regulierbar. Kissen und Kopfrolle aus Polyurethan. Kissen- und Armlehnenbezug aus Leder

#### Sillón

Estructura de acero cromado, o niquelado mate en los acabados natural o negro, o pintada de color negro. Muelles de espiral de acero. Asiento regulable en dos posiciones. Cojín y apoyacabeza acolchados de poliuretano. Tapizado cojines y apoyabrazos de piel.

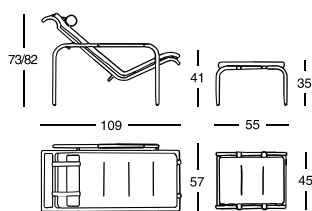

Struttura/Frame/Structure/ Gestell/Estructura



# Gilda CM <sup>888</sup>



Omaggio a

Carlo Mollino

1953

## Poltrona

Struttura in rovere naturale o tinto nero oppure in noce Canaletto colore naturale; verniciatura con finitura a cera. Parti metalliche in ottone nichelsatinato colore nero. Schienale regolabile su quattro posizioni. Imbottitura in poliuretano /fibra poliestere termolegata con molleggio su spirali d'acciaio. Rivestimento sfilabile in stoffa o in pelle.

## Armchair

Frame in natural or black varnished oak, or in natural Canaletto walnut; wax-finished varnish. Black-nickel satin finished brass metal components. Four-position adjustable backrest. Upholstery in polyurethane/heat-bound polyester fibre with suspension on steel springs. Removable fabric or leather cover.

## Fauteuil

Structure en rovere naturel ou teinté noir ou en noyer Canaletto, couleur naturelle; verni finition cirée. Quincaillerie en laiton nickel satiné couleur noire. Dossier réglable sur quatre positions. Rembourrage en polyuréthane/fibre de polyester liée à chaud avec suspension à spirales d'acier. Revêtement déhoussable en tissu ou en cuir.

## Sessel

Gestell aus naturfarbener oder schwarz lackierter Eiche, oder aus naturfarbenem Nussbaum Canaletto; Lackierung mit Wachs-Endbehandlung. Metallteilen aus Messing mit schwarz-vernickelter und mattierter Ausführung. Rückenlehne in vier Positionen verstellbar. Polsterung aus Polyhurethan/wärmegebundener Polyesterfaser mit Federung auf Stahlfedern. Abnehmbarer Bezug aus Stoff oder Leder.

## Butaca

Estructura de roble natural o teñido negro o de nogal Canaletto color natural; pintura con acabado de cera. Herrajes de latón niquelado color mate negro. Respaldo regulable en cuatro posiciones. Acolchado de poliuretano/fibra de poliéster termounida con suspensión de espirales de acero. Tapizado desenfundable de tejido o de piel.

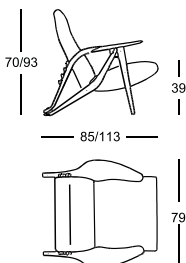

Rovere naturale/Natural oakwood/Rouvre naturel/  
Naturfarbene Eiche/  
Roble natural



Rovere tinto nero/Black varnished oak/  
Rouvre teinté noir/Schwarz-gebeizte Eiche/  
Roble teñido negro



Noce Canaletto/Canaletto walnut/Noyer Canaletto/  
Nussbaum Canaletto/  
Nogal Canaletto





Design

De Pas, D'Urbino, Lomazzi

1968-2023

**Poltrona trasformabile**  
Struttura in poliuretano  
espanso a quote  
differenziate. Rivestimento  
sfilabile in stoffa.

**Convertible armchair**  
Frame in graduated  
polyurethane foam.  
Removable fabric cover.

**Fauteuil transformable**  
Structure en mousse de  
polyuréthane à densité  
variable. Revêtement  
déhoussable en tissu.

**Umwandelbarer Sessel**  
Gestell aus  
Polyurethanschaum mit  
unterschiedlicher Dichte.  
Abnehmbarer Bezug aus  
Stoff.

**Sillón convertible**  
Estructura en espuma de  
poliuretano a densidades  
diferenciadas. Tapizado  
desenfundable en tejido.

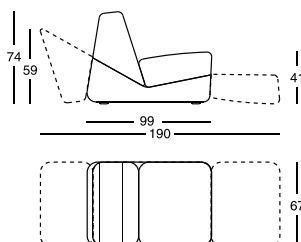



Design

Liisi Beckmann

1966

**Poltrona**

Struttura in poliuretano espanso a quote differenziate. Rivestimento sfilabile realizzabile solo nel tessuto bielastico Samba.

**Armchair**

Graduated polyurethane foam frame. Removable cover only available in bielastic Samba fabric.

**Fauteuil**

Structure en mousse de polyuréthane à densité variable. Revêtement déhoussable seulement dans le tissu Samba biélastique.

**Sessel**

Gestell aus Polyurethanschaum in unterschiedlicher Dichte. Abnehmbarer Bezug nur aus bielastischem Stoff Samba.

**Butaca**

Estructura en espuma de poliuretano a densidades diferenciadas. Tapizado desenfundable solo en tejido bielástico Samba.

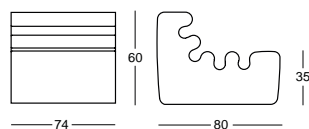



Design

Ludovica+Roberto Palomba

2013

**Poltrona**

Base girevole in acciaio verniciato, colore nero o grafite. Struttura in acciaio. Imbottitura in poliuretano/fibra poliestere termolegata. Rivestimento sfilabile in stoffa o in pelle.

**Armchair**

Revolving base in varnished steel, colours: black or graphite. Steel frame. Upholstery in polyurethane/heat-bound polyester fibre. Removable fabric or leather cover.

**Fauteuil**

Piètement pivotant en acier verni, couleur noire ou graphite. Structure en acier. Rembourrage de polyuréthane/fibre polyester liée à chaud. Revêtement déhoussable en tissu ou en cuir.

**Sessel**

Drehbarer Stahlsockel, graphitfarben oder schwarz lackiert. Stahlgestell. Polsterung aus Polyurethan/wärmegebundener Polyesterfaser. Abnehmbarer Bezug aus Stoff oder Leder.

**Butaca**

Base giratoria de acero barnizado, color negro o grafito. Estructura de acero. Acolchado de poliuretano/fibra poliéster termounida. Tapizado desenfundable de tejido o de piel.

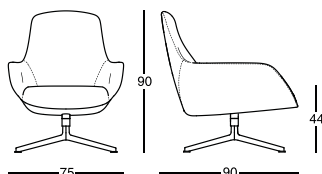

Base/Base/Piètement/Sockel/Base





Design

Ludovica+Roberto Palomba

2013

**Poltrona/bergère. Pouf**

Base girevole in acciaio verniciato, colore nero o grafite. Struttura in acciaio. Imbottitura in poliuretano/fibra poliestere termolegata. Rivestimento sfilabile in stoffa o in pelle

**Armchair/bergère. Pouf**

Revolving base in varnished steel, colours: black or graphite. Steel frame. Upholstery in polyurethane/heat-bound polyester fibre. Removable fabric or leather cover.

**Fauteuil/bergère. Pouf**

Piètement pivotant en acier verni, couleur noire ou graphite. Structure en acier. Rembourrage de polyuréthane/fibre polyester liée à chaud. Revêtement déhoussable en tissu ou en cuir.

**Sessel/bergère. Hocker**

Drehbarer Stahlsockel, graphitfarben oder schwarz lackiert. Stahlgestell. Polsterung aus Polyurethan/wärmegebundener Polyesterfaser. Abnehmbarer Bezug aus Stoff oder Leder.

**Butaca/bergère. Púf**

Base giratoria de acero barnizado, color negro o grafito. Estructura de acero. Acolchado de poliuretano/fibra poliéster termounida. Tapizado desenfundable de tejido o de piel.

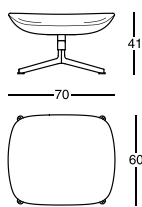
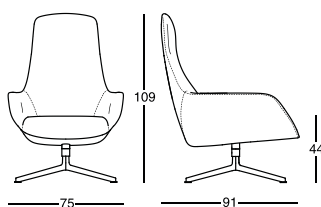

Base/Base/Piètement/Socket/Base



# Lama <sup>921</sup>



Design

Ludovica+Roberto Palomba

2006

#### Chaise longue

Struttura in acciaio verniciato, colore grafite. Imbottitura in poliuretano con molleggio su nastri elastici. Rivestimento sfilabile in stoffa o pelle, o non sfilabile in cuoio.

#### Lounge chair

Graphite varnished steel frame. Polyurethane upholstery with elastic strips suspension. Removable cover in fabric or leather, or non-removable in cowhide.

#### Chaise longue

Structure en acier verni, couleur graphite. Rembourrage de polyuréthane avec suspensions sur sangles élastiques. Revêtement déhoussable en tissu ou cuir, ou pas déhoussable en cuir sellier.

#### Chaiselongue

Lackiertes Stahlgestell, Graphitfarben. Polsterung aus Polyurethan auf elastischen Gurten. Abnehmbarer Bezug aus Stoff oder Leder, oder nicht abnehmbar aus Kernleder.

#### Sillón

Estructura de acero pintado color grafito. Acolchado de poliuretano sobre cintas elásticas. Tapizado desenfundable en tejido o piel, o non desenfundable en cuero.

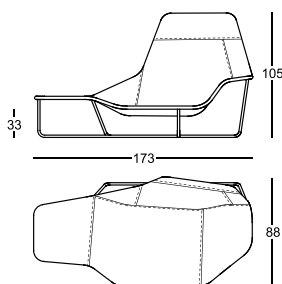

# Maggiolina <sup>900</sup>



Design

Marco Zanuso

1947

## Chaise longue

Struttura in acciaio inox lucidato, o nichelsatinato colore naturale o nero, oppure verniciato nero. Scocca in cuoio pigmentato 90. Imbottitura cuscino schienale in piuma d'oca. Imbottitura cuscino seduta in poliuretano/Dacron Du Pont. Rivestimento, cuscini e braccioli in stoffa, Ecofire o pelle.

## Lounge chair

Polished or black painted steel tubular frame, or with natural or black nickel-satin finish. Sling in cowhide pigmentato 90. Back cushion in new goose feathers. Seat cushion upholstered in polyurethane/Dacron Du Pont. Cushions and armrests covered with fabric, Ecofire or leather.

## Chaise longue

Structure en acier inox poli, nickel satiné dans les finitions naturelle ou noire, ou verni couleur noire. Support en cuir sellier pigmentato 90. Coussin dossier en plume d'oie. Coussin assise en polyuréthane/Dacron Du Pont. Revêtement, coussins et accoudoirs en tissu, Ecofire ou cuir.

## Chaiselongue

Gestell aus poliertem, oder schwarz lackiertem Inox-Stahl oder mit naturfarben- oder schwarz-vernickeltem und mattiertem Finish. Tragschale aus Kernleder pigmentato 90. Rückenkissen gefüllt mit reinen Gänsefedern. Sitzkissen aus Polyurethan/Dacron Du Pont. Kissen- und Armlehnen-Bezug aus Stoff, Ecofire oder Leder.

## Sillón

Estructura de acero inox pulido o niquelado mate en los acabados natural o negro, o pintado de color negro. Soporte para los cojines de cuero pigmentato 90. Cojín respaldo acolchado de plumas de ganso. Cojín asiento acolchado de poliuretano/Dacron Du Pont. Tapizado cojines y apoyabrazos de tejido, Ecofire o piel.

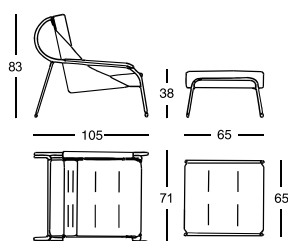

Struttura/Frame/Structure/ Gestell/Estructura





# Moretta <sup>851</sup>



Design

Bernard Marstaller

1917

**Poltroncina con schienale basculante**  
Struttura in faggio, colore naturale. Schienale inclinabile. Rivestimento sfilabile in Telastrong o in cuoio.

**Armchair with tilting backrest**  
Natural beech frame. Tilting back. Removable cover in Telastrong or cowhide.

**Petit fauteuil avec dossier inclinable**  
Structure en hêtre, couleur naturelle. Dossier inclinable. Revêtement déhoussable en Telastrong ou en cuir sellier.

**Armlehnstuhl mit verstellbarer Rückenlehne**  
Gestell aus Buche, naturfarben. Schräg verstellbare Rückenlehne. Abnehmbarer Bezug aus Telastrong oder aus Kernleder.

**Butaquita con respaldo basculante**  
Estructura de haya, color natural. Respaldo abatible. Tapizado desenfundable en Telastrong o en cuero.

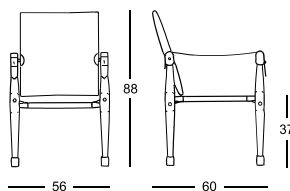

# Nena Lounge <sup>928</sup>



Design

Lanzavecchia + Wai

2023

## Poltrona

Struttura in acciaio verniciato colore grafite o nero opaco. Imbottitura sedile in poliuretano a quote differenziate/Dacron

Du Pont, imbottitura schienale in poliuretano schiumato autoestinguente. Rivestimento sfilabile in stoffa o in pelle.

## Armchair

Steel frame varnished matt graphite or black. Seat upholstered in graduated polyurethane/Dacron Du Pont; backrest upholstered

with self-extinguishing polyurethane foam. Removable cover in fabric or leather.

## Fauteuil

Structure en acier verni graphite ou noir mat. Assise rembourré en polyuréthane à densité variable/Dacron Du Pont, dossier rembourré

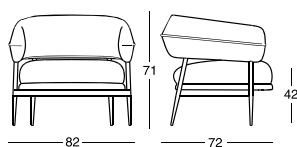



en mousse de polyuréthane autoextinguible. Revêtement déhoussable en tissu ou en cuir.

**Sessel**  
Gestell aus matt schwarz oder graphit lackiertem Stahl. Sitz -Polsterung aus Polyurethan mit unterschiedlicher

Dichte/ Dacron Du Pont. Rückenlehne mit selbstlöschendem Polyurethanschaum gepolstert. Abnehmbarer Bezug aus Stoff oder Leder.

**Butaca**  
Estructura de acero pintado en los colores grafito o negro mate. Acolchado del asiento de poliuretano a densidades diferenciadas/

Dacron Du Pont; acolchado del respaldo de espuma de poliuretano autoextintivo. Tapizado desfundable de tejido o piel.

Struttura/Frame/Structure/ Gestell/Estructura





Design

Constance Guisset

2019

**Poltrona**

Gambe in legno massello di acero laccato nero. Struttura in acciaio. Imbottitura in poliuretano/fibra poliestere termolegata. Rivestimento sfilabile in stoffa o pelle.

**Armchair**

Legs in black laquered solid maple wood. Steel frame. Upholstery with self-extinguishing polyurethane foam/heat-bound polyester fibre. Removable cover in fabric or leather.

**Fauteuil**

Pieds en bois massif d'érable laqué noir. Structure en acier. Rembourrage en mousse de polyuréthane autoextinguible/fibre de polyester liée à chaud. Revêtement déhoussable en tissu ou en cuir.

**Sessel**

Beine aus schwarz lackiertem massiven Ahornholz. Stahl-Gestell. Polsterung aus selbstlöschendem Polyurethan-Schaum/wärmegebundener Polyesterfaser. Abnehmbarer Bezug aus Stoff oder Leder.

**Butaca**

Patas de madera maciza de arce lacada negro. Estructura de acero. Acolchado de espuma de poliuretano autoextintivo/fibra poliéster termounida. Tapizado desenfundable de tejido o de piel.

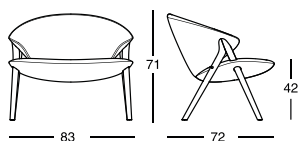

# Rider<sup>926</sup>



Design

Ludovica+Roberto Palomba

2020

**Chaise longue basculante**  
Struttura in poliuretano rigido con imbottitura in poliuretano a quote differenziate. Rivestimento struttura in cuoio 95. Trapuntino amovibile in poliuretano/fibra poliestere termolegata rivestito in tessuto. A richiesta è disponibile un poggiatesta con imbottitura in poliuretano/fibra poliestere termolegata rivestito in tessuto sfoderabile.

**Tilting lounge chair**  
Stiff polyurethane frame with upholstery in graduated polyurethane. Frame covered with cowhide 95. Removable topper made of polyurethane/heat-bound polyester fibre, covered with fabric. Upon request one headrest cushion upholstered with polyurethane/head-bound polyester fibre, covered with removable fabric, is available.

**Chaise longue basculant**  
Structure en polyuréthane rigide avec rembourrage en polyuréthane à densité variable, recouverte en cuir sellier 95. Topper amovible en polyuréthane/fibre polyester liée à chaud recouvert en tissu. Un appui-tête avec rembourrage en polyuréthane/fibre polyester liée à chaud recouvert en tissu déhoussable, est disponible sur demande.

**Schaukel-Chaiselongue**  
Gestell aus steifem Polyurethan mit Polsterung aus Polyurethan in unterschiedlicher Dichte. Gestell bezogen mit Kernleder 95. Abnehmbares Topper aus Polyurethan/wärmegebundener Polyesterfaser mit Stoff-Bezug. Auf Nachfrage ist ein Kopfkissen lieferbar, das mit Polyurethan/wärmegebundener Polyesterfaser gepolstert und mit abnehmbarem Stoff-Bezug ist.

**Chaise longue basculante**  
Estructura de poliuretano rígido con acolchado de poliuretano a densidades diferenciadas. Tapizado de la estructura en cuero 95. Topper retirable de poliuretano/fibra poliéster termounida tapizado en tejido. Sobre pedido es disponible un cojín apoyacabeza acolchado de poliuretano/fibra poliéster termounida tapizado en tejido desenfundable.

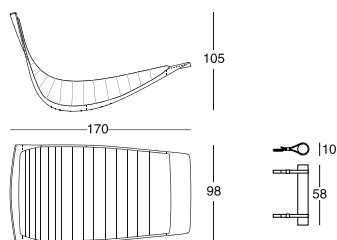

# Sacco Small <sup>278</sup>

# Sacco Medium <sup>279</sup>

# Sacco <sup>280</sup>



Design

Gatti, Paolini, Teodoro

1968

IN/OUT

#### Poltrone anatomiche

Involucro contenente palline di polistirolo espanso ad alta resistenza. Rivestimento in Vip (anche per esterni, antibatterico con trattamento Silverguard® e antimacchia

con trattamento Permablock 3®), Tulip, Pied de poule e pelle. Le versioni in Tulip e Pied de poule sono sfoderabili.

#### Anatomical easy chairs

Envelope containing highly resistant expanded polystyrene pellets. Cover in: Vip (also for outdoor, antibacterial with Silverguard® and stain-

proof with Permablock 3® treatment), Tulip, Pied de poule and leather. The versions in Tulip and Pied de poule are removable.

#### Fauteuils anatomiques

Housse contenant de petites billes de polystyrène à grande résistance. Revêtement en: Vip (aussi pour extérieurs, antibactérien avec traitement Silverguard®

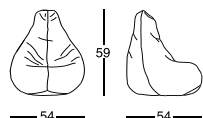

278

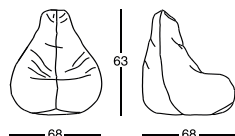

279

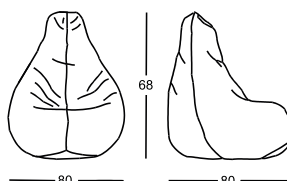

280



et antitache avec traitement Permablock 3®), Tulip, Pied de poule et cuir. Les versions en Tulip et Pied de poule sont déhoussables.

**Anatomische Sessel**  
Hülle mit aufgeschäumten Polystyrol-Kügelchen gefüllt, widerstandsfähig. Bezug aus: Vip (auch fürs Freie, anti-bakteriell mit Behandlung Silverguard®)

und Fleckenschutz mit Behandlung Permablock 3®), Tulip, Pied de poule und Leder. Die Bezüge aus Tulip und Pied de poule sind abnehmbar.

**Butacas anatómicas**  
Bolsa rellena de bolitas de poliestirol expando de alta resistencia. Tapizado en: Vip (también para exteriores, antibacteriano con tratamiento Silverguard® y

antimancha con tratamiento Permablock 3®), Tulip, Pied de poule y piel. Las versiones en Tulip y Pied de poule son desenfundables.

Rivestimento/Cover/Revêtement/Bezug/Tapizado

VIP



Pied de poule



Tulip



# Sant'Elia <sup>850</sup>



Design

Giuseppe Terragni

1936

**Poltroncina**

Struttura in acciaio inox 18/8.  
Imbottitura in poliuretano.  
Rivestimento in pelle.

**Armchair**

18/8 stainless steel frame.  
Polyurethane upholstery.  
Leather cover.

**Petit fauteuil**

Structure en acier inox  
18/8. Rembourrage en  
polyuréthane. Revêtement  
en cuir.

**Armlehnstuhl**

Gestell aus Inox-Stahl 18/8.  
Polsterung aus Polyurethan.  
Bezug aus Leder.

**Butaquita**

Estructura de acero  
inox 18/8. Acolchado de  
poliuretano. Tapizado en piel.

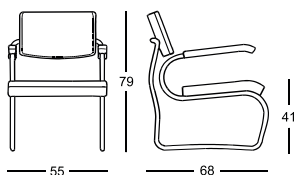



# Susanna <sup>852</sup>



Design

Gabriele Mucchi

1983

## Poltroncina

Struttura portante in tubo di acciaio cromato, o nichel satinato colore naturale o nero, oppure verniciato nero. Telaio porta-cuscini in acciaio verniciato nero, regolabile su due posizioni. Imbottitura cuscini in poliuretano/ fibra poliestere termolegata. Rivestimento cuscini sfilabile in stoffa o pelle. Nella versione con cuscini rivestiti in tessuto, i braccioli sono in pelle 95.

## Armchair

Carrying frame in chromium-plated, or in natural or black nickel-satin finished, or black painted tubular steel. Adjustable two-position cushion support in black painted steel. Cushions upholstery in polyurethane/ heat-bound polyester fibre. Removable cushions cover in fabric or leather. The model with fabric covered cushions features the armrests covered with leather 95.

## Petit fauteuil

Structure portante en tube d'acier chromé, ou nickel satiné, dans les finitions naturelle ou noire, ou verni noir. Châssis porte-coussins en acier verni noir, réglable sur deux positions. Rembourrage coussins en polyuréthane/fibre polyester liée à chaud. Revêtement coussins déhoussable en tissu ou cuir. Dans la version avec les coussins en tissu, les accoudoirs sont en cuir 95.

## Armlehnstuhl

Gestell aus verchromtem oder schwarz-lackiertem Stahlrohr, oder mit naturfarben-oder schwarz-vernickeltem und mattiertem Finish. Kissenträger-Rahmen aus schwarz lackiertem Stahl, in zwei Positionen verstellbar. Polsterung der Kissen aus Polyhurethan/ wärmegebundener Polyesterfaser. Abnehmbarer Kissen-Bezug aus Stoff oder Leder. Für die Version mit Stoff-bezogenen Kissen, sind die Armlehnen mit Leder 95.

## Butaquita

Estructura tubular de acero cromado, o niquelado mate en los acabados natural o negro, o lacado negro. Bastidor porta-cojines de acero pintado de negro, regulable en dos posiciones. Acolchado de los cojines de poliuretano/fibra poliéster termounida. Tapizado desenfundable de los cojines de tejido o de piel. Por el modelo con cojines tapizados de tejido, los apoyabrazos están tapizados de piel 95.

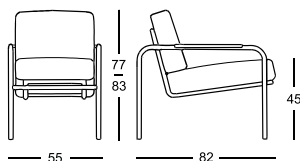

Struttura/Frame/Structure/Gestell/Estructura





Tavolini  
Small tables  
Petites tables  
Couchtische  
Mesitas

82–105

# Arabesco CM<sup>697</sup>

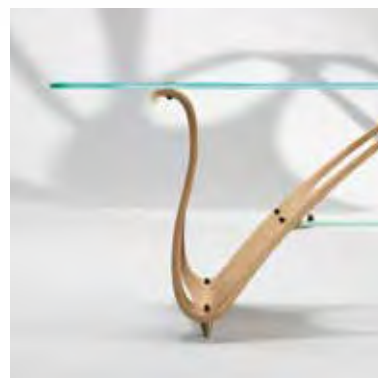
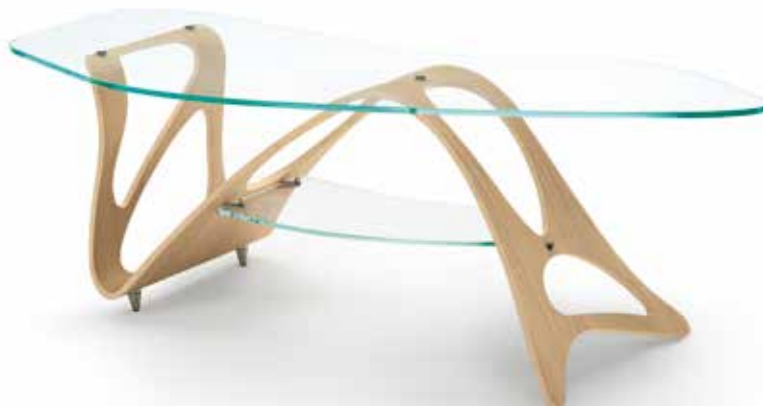

Omaggio a

Carlo Mollino

1949

## Tavolino

Struttura in multistrati curvato, in rovere naturale o tinto nero; verniciatura con finitura a cera. La struttura è fissata al piano tramite bussole passanti. Piano superiore in cristallo temperato, piano inferiore in cristallo temperato, entrambi rispettivamente in cristallo extra-chiaro per la versione in rovere naturale o in cristallo fumè grigio per la versione in rovere tinto nero.

## Small table

Bent plywood frame in natural or black varnished oak; wax-finished varnish. The frame is attached to the top with an internally threaded screw. Top shelf in tempered plate glass; bottom shelf in tempered plate glass, both either extra-clear, matching the frames in natural oak or in smoky grey plate glass, matching the black varnished oak frame.

## Petite table

Structure en contreplaqué courbé, plaqué en rovere naturel ou teinté noir; verni finition cirée. La structure est fixée au plateau avec des traversées. Plateau supérieur en verre trempé, les deux respectivement en verre extra-clair pour la version en rovere naturel ou en verre gris fumé pour la version en rovere teinté noir.

## Couchtisch

Gestell aus gebogenem Schichtholz, mit naturfarbener oder schwarz lackierter Eiche furniert; Lackierung mit Wachs-Endbehandlung. Das Gestell ist mittels Durchführungsbuchsen am Gestell verbunden. Obere Platte aus gehärtetem Kristallglas; untere Platte aus gehärtetem Kristallglas, beide entweder extra-klar für die Version aus naturfarbener Eiche oder grau rauchfarben für die Version aus schwarz lackierter Eiche.

## Mesita

Estructura en madera contrachapada curvada, aplacada en roble natural o teñido negro; pintura con acabado de cera. La estructura se fija al sobre con brújulas que pasan a través. Superficie superior en cristal templado; superficie inferior en cristal templado, ambos respectivamente en cristal extra-claro para la versión de roble natural o en cristal gris humo para la versión de roble teñido negro.

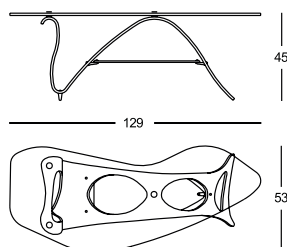

### Struttura/Frame/Structure/ Gestell/Estructura

Rovere naturale/  
Natural  
oakwood/  
Rouvre naturel/  
Naturfarbene  
Eiche/Roble  
natural

Rovere tinto nero/  
Black varnished  
oak/Rouvre teinté  
noir/Schwarz-  
gebeizte Eiche/  
Roble teñido  
negro



### Piano/Top/Plateau/Platte/Sobre

Cristallo extra-  
chiaro/Extra-clear  
plate glass/Verre  
extra-clair/Extra-  
klares Kristallglas/  
Cristal extra-claro

Cristallo fumé  
grigio/Smoky  
grey plate glass/  
Verre gris fumé/  
Rauchfarbenes  
Kristallglas/Cristal  
gris humo





Design

Achille Castiglioni

1987

**Tavolino a doppia altezza con ripiani rotanti**

Struttura in medium density fiberboard, verniciatura gofrata antigraffio nei colori bianco, nero o bordeaux. Snodo in acciaio verniciato nero nelle versioni nera o bordeaux oppure bianco nella versione bianca.

**Double height small table with rotating shelves**

Frame in medium density fiberboard finished with scratch resistant embossing in the shades white, black or burgundy. Steel articulated joint in black for the models black or burgundy, or in the shade white for the white model.

**Petite table à deux hauteurs à étagères pivotantes**

Structure en medium density fiberboard, vernie antirayures dans les couleurs blanche, noire ou bordeaux. Articulation en acier verni noir dans les versions noire ou bordeaux ou verni blanc pour la version blanche.

**Zweiteiliger verstellbarer mit Drehregalen**

Gestell aus Medium Density Fiberboard mit Anti-Kratzer-Lackierung, in den Farben weiß, schwarz oder burgunderrot. Verbindungsstück aus schwarz-lackiertem Stahl für die Modelle in den Farben schwarz oder burgunderrot; oder weiß lackiert für die weiße Version.

**Mesita de doble altura con estantes giratorios**

Estructura en medium density fiberboard, laca en relieve anti-rasguño en los colores blanco, negro o burdeos. Articulación de acero pintado negro por las versiones en negro o burdeos, o blanco por la versión en blanco.

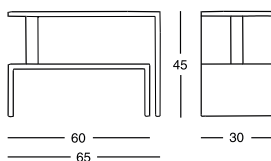

Verniciatura gofrata/Embossed paint/Vernissage gaufré/Gaufrierte Lackierung/Lacadura anti-rasguño



Snodo/Articulated joint/Articulation/ Verbindungsstück/Articulación



# Butterfly<sup>695</sup>

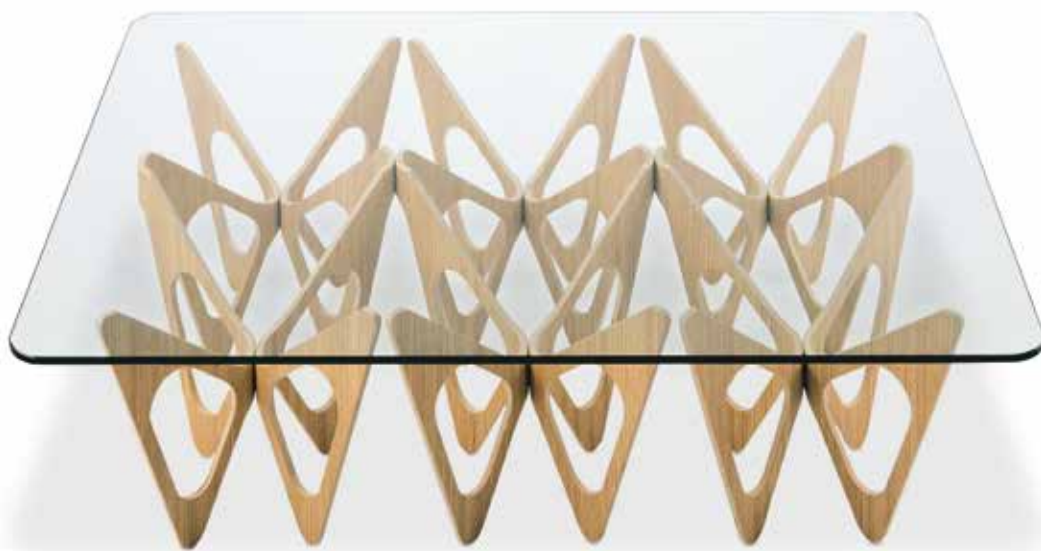

Design

Alexander Taylor Zanotta - E&Y Co-Edition

2006

## Tavolino

Struttura in multistrati curvato, impiallacciato in rovere naturale o tinto bianco o nero. Piano in cristallo temperato.

## Small table

Bent plywood frame, veneered with natural, white or black painted oak. Top in tempered plate glass.

## Petite table

Structure en contreplaqué courbé, plaqué en rouvre, couleur naturelle ou teinté blanc ou noir. Plateau en cristal trempé.

## Beistelltisch

Untergestell aus gebogenem Sperrholz, eichenfurniert, naturfarben, weiß oder schwarz lackiert. Platte aus gehärtetem Kristallglas.

## Mesita

Estructura con panel multiestrato curvado, contrachapado en roble natural, teñido blanco o negro. Sobre de cristal templado.

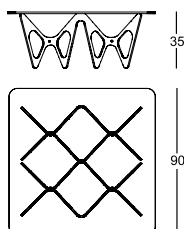

Rovere tinto bianco/White varnished oak/  
Rouvre teinté blanc/Weiß gebeizte Eiche/  
Roble teñido blanco



Rovere naturale/Natural oakwood/  
Rouvre naturel/Naturfarbene Eiche/Roble natural



Rovere tinto nero/Black varnished oak/  
Rouvre teinté noir/Schwarzgebeizte Eiche/  
Roble teñido negro



# Carlino CM<sup>335</sup>



Omaggio a

Carlo Mollino

1938

#### Contenitore di servizio

Struttura e cassetto in legno verniciato nei colori bianco e nero. Pianetto d'appoggio in cristallo nei medesimi colori. Prevede il fissaggio a parete.

#### Service storage unit

Frame and drawer in painted wood, in the shades black and white. Plate glass top in the same colours. It must be fastened to wall.

#### Petit meuble d'appoint

Structure et tiroir en bois peint couleur noir et blanc. Tablette d'appui en verre dans les mêmes couleurs. Il prévoit le montage mural.

#### Service-Behälter

Gestell und Schublade aus lackiertem Holz, in den Farben weiß und schwarz. Platte aus Kristallglas in den gleichen Farben. Für die Wandmontage vorgesehen.

#### Mueble de apoyo

Estructura y cajón de madera lacada en los colores blanco y negro. Superficie de apoyo en cristal en los mismos colores. Debe ser fijado a la pared.

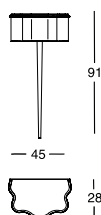

Struttura/Frame/Structure/  
Gestell/Estructura



# Cumano <sup>630</sup>



Design

Achille Castiglioni

1978

## Tavolino pieghevole

Struttura e piano in acciaio, colore nero, bianco, amaranto, antracite o azzurro acqua. Giunto scorrevole in ABS. E' dotato di un gancio per appenderlo a parete.

## Folding table

Steel frame and top. Colours: black, white, amaranth, anthracite or light blue. ABS sliding joint. It is equipped with a hook for hanging.

## Petite table pliante

Structure et plateau en acier, dans les couleurs noire, blanc, rouge amarante, anthracite ou bleu mer. Joint coulissant en ABS. Il est équipé d'un crochet pour l'accrocher au mur.

## Klapptisch

Gestell und Platte aus Stahl in den Farben Schwarz, weiß, Anthrazit, Amaranthrot oder Hellblau. Verschiebbares Gelenk aus ABS. Er ist mit einem Haken zum Aufhängen an der Wand ausgestattet.

## Mesita plegable

Estructura y sobre de acero, en los colores: negro, blanco, granate, antracita o azul agua. Anilla corredera en ABS. Esta equipado de un gancho para colgarlo a la pared.

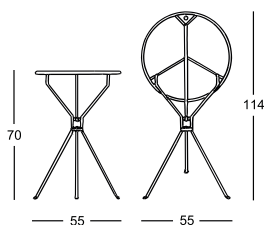

Struttura/Frame/Structure/Gestell/Estructura





# Echino <sup>667</sup>



Design

Sebastian Herkner

2019

## Tavolino

Gambe in vetro soffiato a tre strati nei colori fumè o ambra. Piani in lamiera di acciaio nichelsatinato colore naturale o nero.

## Small table

Three-layered blown glass legs in the shades smoky grey or amber. Steel sheet top with natural or black nickel-satin finish.

## Petite table

Pieds en verre soufflé à trois couches dans les couleurs gris-fumé ou ambre. Plateau en tôle d'acier dans les finitions nickel satiné naturel ou noir.

## Beistelltisch

Beine aus dreischicht-geblasenem Glas in den Farben rauchgrau oder Bernstein. Platten aus Stahlblech mit naturfarben oder schwarz vernickeltem Finish.

## Mesita

Patatas de vidrio soplado de tres capas en color gris ahumado o ámbar. Sobre de chapa de acero en los acabados níquel satinado natural o negro.

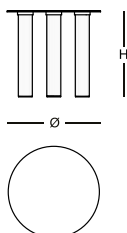

Dimensioni/Sizes/Dimensions/  
Abmessungen/Medidas

Ø 48 H 44 cm  
Ø 68 H 34 cm

Gambe/Legs/Pieds/Beine/Patas





Design

Anna Deplano

1997-1999

**Tavolino con rotelle**

Struttura in acciaio verniciato, colore alluminio. Pianetti in laminato plastico stratificato, colore bianco.

**Castor-mounted table**

Aluminium- painted steel frame. Shelves in layered plastic laminate in white.

**Petite table avec roulettes**

Structure en acier verni, couleur aluminium. Plateaux en laminé plastique stratifié, couleur blanc.

**Tischchen mit Rollen**

Gestell aus alufarben lackiertem Stahl. Platten aus massivem weißen Plastiklaminat.

**Mesita con ruedas**

Estructura de acero pintado de color aluminio. Repisas de laminado plástico estratificado, de color blanco.

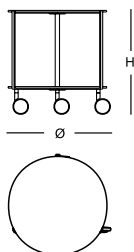

**Dimensioni/Sizes/Dimensions/  
Abmessungen/Medidas**

Ø 50 H 53,5 cm

Ø 75 H 37 cm

Ø 110 H 37 cm

# Graphium 681/682



Design

Garcia Cumini

2019

## Tavolini

Struttura in acciaio verniciato colore nero. Piani in marmo Calacatta grigio, in marmo rosso Lepanto o in marmo Sahara Noir con verniciatura protettiva antimacchia, in poliestere trasparente opaco.

## Small tables

Black varnished steel frame. Tops available either in grey Calacatta marble, in red Lepanto marble or in Sahara Noir marble with stain-resistant protective varnish, in clear matt polyester.

## Petites tables

Structure en acier verni noir. Plateaux en marbre Calacatta gris, en marbre rouge Lepanto ou en marbre Sahara Noir avec peinture de protection anti-taches en polyester transparent opaque.

## Couchtische

Gestell aus schwarz lackiertem Stahl. Platten aus graufarbenem Calacatta Marmor, oder aus rotem Lepanto Marmor oder aus Sahara Noir Marmor mit Fleckenschutz Lackierung aus klarem mattem Polyester.

## Mesitas

Estructura en acero pintado negro. Sobres de mármol Calacatta gris, de mármol Lepanto rojo o de mármol Sahara Noir con laca de protección antimancha en poliéster opaco transparente.

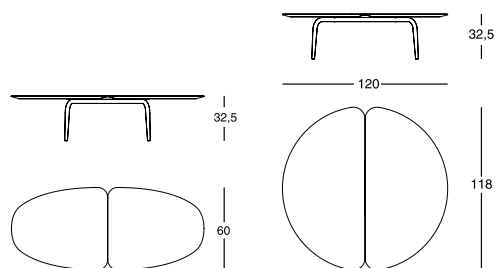

681

682

Dimensioni/Sizes/Dimensions/  
Abmessungen/Medidas

140x60 cm  
200x60 cm  
120x118 cm

## Piano/Top/Plateau/Platte/Sobre

Marmo Calacatta/  
Calacatta marble/  
Marbre Calacatta/  
Calacatta  
Marmor/Mármol  
Calacatta

Marmo Lepanto/  
Lepanto marble/  
Marbre Lepanto/  
Lepanto Marmor/  
Mármol Lepanto

Marmo Sahara  
Noir/Sahara  
Noir marble/  
Marbre Sahara  
Noir/Sahara Noir  
Marmor/Mármol  
Sahara Noir



# Niobe 648/671



Design

Federica Capitani

2016

## Tavolino

Struttura in acciaio verniciato colore bianco o nero. Piani in marmo bianco di Carrara, in marmo nero Marquinia o in marmo Emperador, con verniciatura protettiva antimacchia, in poliестere trasparente opaco.

## Small table

Steel frame painted in the shades black or white. Tops available either in white Carrara marble, in black Marquinia marble or in Emperador marble, with stain resistant protective varnish, in clear matt polyester.

## Petite table

Structure en acier verni blanc ou noir. Plateaux en marbre blanc de Carrare, en marbre noir Marquinia ou en marbre Emperador, avec vernis de protection anti-taches de polyester transparent mat.

## Beistelltisch

Gestell aus weiß oder schwarz lackiertem Stahl. Platten aus weißem Carrara Marmor, oder aus schwarzem Marquinia Marmor oder aus Emperador Marmor, mit Fleckenschutz Lackierung aus klarem mattem Polyester.

## Mesita

Estructura de acero pintado blanco o negro. Sobres en marmól blanco de Carrara, en marmól negro Marquinia o en marmól Emperador, con laca de protección anti mancha, en poliéster mate transparente

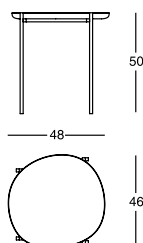

648

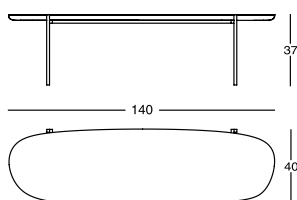

671

Struttura/Frame/Structure/  
Gestell/Estructura



## Piano/Top/Plateau/Platte/Sobre

Marmo Marquinia/  
Marquinia  
marble/Marbre  
Marquinia/  
Marquinia/  
Marmor/Mármol  
Marquinia

Marmo  
Emperador/  
Emperador  
marble/Marbre  
Emperador/  
Emperador  
Marmor/Mármol  
Emperador

Marmo di Carrara/  
Carrara marble/  
Marbre de  
Carrare/Carrara  
Marmor/Mármol  
de Carrara





Design

Emaf Progetti

2005

**Comodino con cassetto**  
Struttura in acciaio verniciato colore grafite. Maniglia in alluminio verniciato colore grafite. Cassetto in medium density fiberboard impiallacciato in rovere naturale, tinto grigio o bianco.

**Night table with drawer**  
Graphite painted steel frame. Handle in graphite painted aluminium. Drawer in medium density fiberboard veneered with natural oak or varnished grey or white.

**Table de chevet avec tiroir**  
Structure en acier verni couleur graphite. Poignée en aluminium verni couleur graphite. Tiroir en medium density fiberboard, contreplaqué en rovere naturel, teinté gris ou blanc.

**Nachtisch mit Schublade**  
Gestell aus Graphit lackiertem Stahl. Griff aus Graphit lackiertem Aluminium. Schublade aus medium density fiberboard mit Eichenfurnier, naturfarben, grau oder weiß gebeizt.

**Mesita de noche con cajón**  
Estructura de acero pintado grafito. Manecilla de aluminio pintado color grafito. Cajón de medium density fiberboard enchapado de roble natural, teñido gris o blanco.

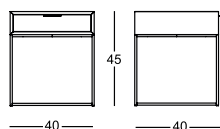

**Cassetto/Drawer/Tiroir /Schublade/Cajón**

Rovere tinto bianco/White varnished oak/  
Rouvre teinté blanc/Weiß gebeizte Eiche/  
Roble teñido blanco



Rovere tinto grigio/Grey varnished oak/  
Rouvre teinté gris/  
Grau gebeizte Eiche/Roble teñido gris



Rovere naturale/  
Natural oakwood/  
Rouvre naturel/  
Naturfarbene Eiche/Roble natural



# Quaderna Coffee Table <sup>656</sup>

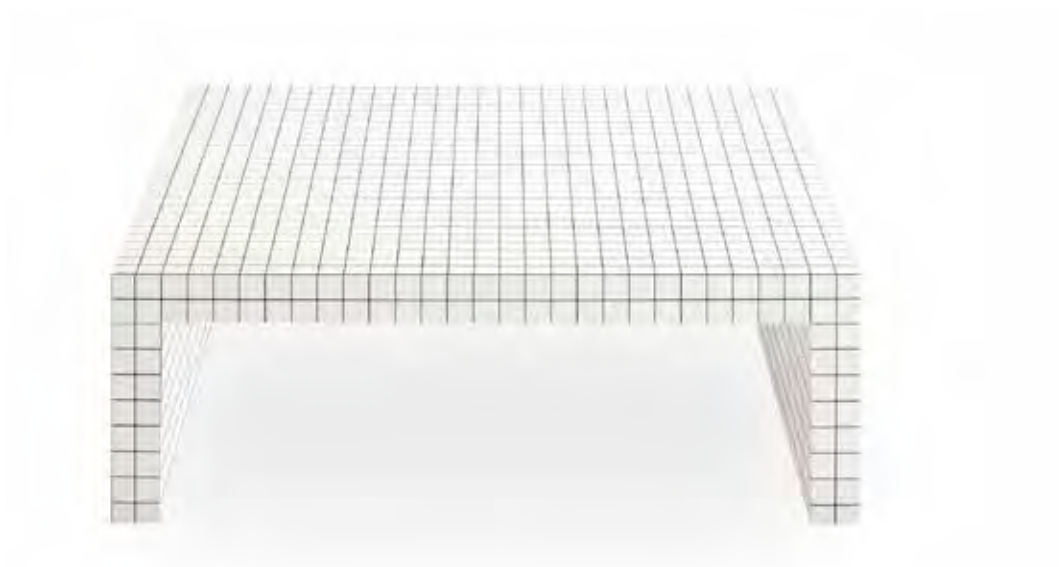

Design

Superstudio

1969-1972

## Tavolino

Struttura in legno tamburato placcato laminato Print, colore bianco, a stampa digitale a quadretti con interasse di 3 cm.

## Coffee table

Honeycomb core structure coated with white Print laminate, digitally printed with black squares at 3 cm spacing.

## Petite table

Structure en panneau alvéolaire plaqué en laminé Print, couleur blanche, imprimé en digital à carrés noirs avec entraxe de 3 cm.

## Beistelltisch

Gestell aus Sperrholz mit weißem Print Laminat belegt. Digitaldruck mit kariertem Muster, Linienabstand 3 cm.

## Mesita

Estructura de madera aplacada con laminado Print, color blanco, a impresión digital en cuadritos negros de 3 cm.

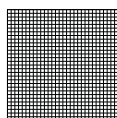
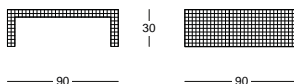

# Quaderna Small Table <sup>710</sup>

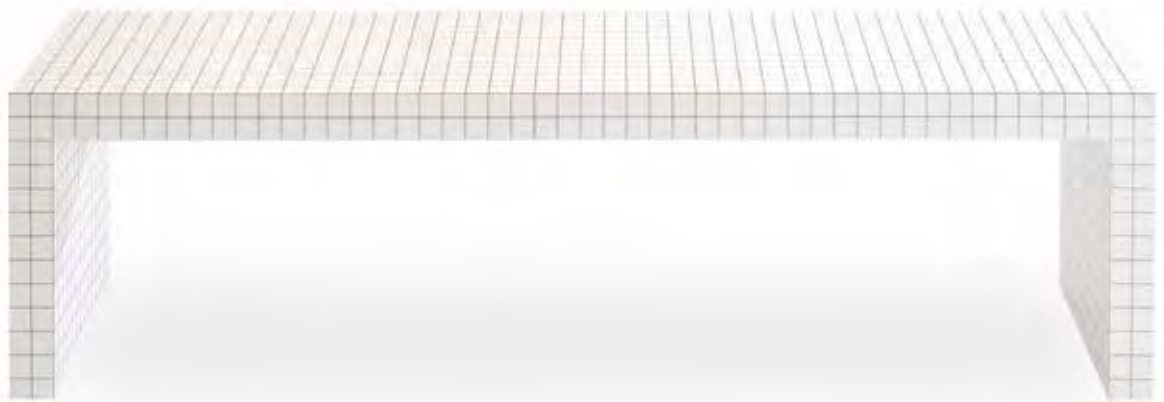

Design

Superstudio

1969-1972

## Tavolino

Struttura in legno tamburato placcato laminato Print, colore bianco, a stampa digitale a quadretti con interasse di 3 cm.

## Small table

Honeycomb core structure coated with white Print laminate, digitally printed with black squares at 3 cm spacing.

## Petite table

Structure en panneau alvéolaire plaqué en laminé Print, couleur blanche, imprimé en digital à carrés noirs avec entraxe de 3 cm.

## Beistelltisch

Gestell aus Sperrholz mit weißem Print Laminat belegt. Digitaldruck mit kariertem Muster, Linienabstand 3 cm.

## Mesita

Estructura de madera aplacada con laminado Print, color blanco, a impresión digital en cuadrillos negros de 3 cm.

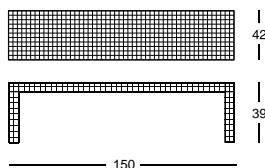

# Servomuto <sup>360</sup>



Design

Achille Castiglioni

della serie Servi di Achille & Pier Giacomo Castiglioni

1974

## Tavolino

Base in polipropilene e asta in acciaio verniciato colore nero o bianco. Pianetto in laminato plastico stratificato, colore bianco/nero, reversibile.

## Small table

Base in polypropylene and steel rod painted, colour black or white. Top in reversible black/white plastic laminate.

## Petite table

Base en polypropylène et tige en acier peint en couleur noir ou blanc. Plateau en laminé plastique stratifié, couleur blanc/noir, réversible.

## Beistelltisch

Fuß aus Polypropylen und Stange aus lackiertem Stahl, Farbe schwarz oder weiß. Tischplatte aus massivem Plastiklaminat, in den Farben weiß/schwarz, umkehrbar.

## Mesita

Base de polipropileno y soporte de acero pintado, color negro o blanco. Repisa de laminado plástico estratificado, en los colores blanco/negro, reversible.

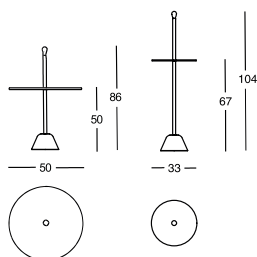

Struttura/Frame/Structure/Gestell/Estructura



Pianetti/Shelves/Plateaux/Platten/Repisas





# Sgabillo <sup>650</sup>



Design

Max Bill

1950

## Sgabello

Struttura in multistrati di betulla verniciata, colore naturale, o in medium density fiberboard, verniciatura gofrata antigraffio, colore nero.

## Stool

Structure in natural varnished, layered birch or in black lacquered medium density fiberboard finished with scratch-resistant embossing.

## Tabouret

Structure en contreplaqué de bouleau verni, couleur naturelle ou en medium density fiberboard, vernissage gaufré antirayures, couleur noire.

## Hocker

Gestell aus Birkensperrholz, naturfarben oder aus Medium Density Fiberboard, gaufrierte Anti-Kratzer-Lackierung, schwarz.

## Taburete

Estructura de madera chapada de abedul, barnizada de color natural o de medium density fiberboard, laca en relieve anti-rasguño, color negro.

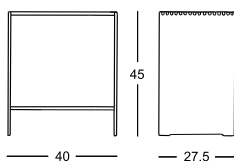

Struttura/Frame/Structure/Gestell/Estructura





Design

Gabriele Rosa

2017

**Comodino con cassetto**

Struttura e piano in acciaio verniciato colore bianco, nero o grafite. Piano e vano portaoggetti in cuoio pigmentato 90. Il vano è accessibile mediante apertura a ribalta.

**Nightstand with drawer**

Top and frame in white, black or graphite painted steel. Top and storage space in cowhide pigmentato 90. The storage is accessed by a dropleaf opening.

**Table de chevet avec tiroir**

Structure et plateau en acier verni couleur blanche, noire ou graphite. Plateau et élément porte-objets en cuir sellier pigmentato 90. L'élément est accessible par une ouverture basculante.

**Nachttisch mit Schublade**

Gestell und Platte aus weiß-, schwarz- oder graphitfarben- lackiertem Stahl. Platte und Ablagefach aus Kernleder pigmentato 90. Das Ablagefach ist mit Kippöffnung versehen.

**Mesita de noche con cajón**

Estructura y sobre de acero pintado de color blanco, negro o grafito. Sobre y compartimento portaobjetos de cuero pigmentato 90. Se puede acceder al compartimento mediante apertura abatible.

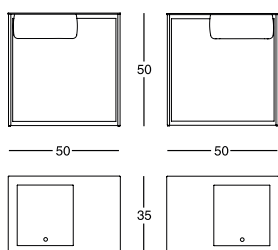

Struttura/Frame/Structure/Gestell/Estructura



# Tempo <sup>631</sup>



Design

Prospero Rasulo

2001

**Tavolino**

Coni in poliuretano rigido, asta di sostegno in acciaio, laccatura lucida nei colori della cartella.

**Small table**

Stiff polyurethane cones, steel stem, glossy lacquer in the colours shown on the colour card.

**Table basse**

Cônes en polyuréthane rigide, tige de soutien en acier, laquage brillant dans les couleurs de la fiche.

**Tischchen**

Kegel aus steifem Polyurethan, Trägerstange aus Stahl mit poliertem Glanzlack in den Farben der Musterkarte.

**Mesita**

Conos de poliuretano rígido, asta central de acero, lacados brillante en los colores del muestrario.

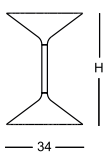

H 36 cm  
H 50 cm

Struttura/Frame/Structure/Gestell/Estructura





Design

Prospero Rasulo

2006

IN/OUT

#### Tavolino

Struttura in gres fine porcellanato antigelivo per esterni, con doppia smaltatura manuale a spessore controllato, cotto a 1250°C con un ciclo di lavorazione di 36 ore, colore verde-giallo.

#### Occasional table

Freeze resistant frame in fine porcelainized grès for outdoors use with thickness controlled two-layering applied by hand and baked at 1250°C with a 36-hour processing cycle, colour green-yellow..

#### Petite table

Structure en grès fin émaillé résistante au gel pour externes, avec double émaillage manuel à épaisseur contrôlée, cuit à 1250°C en appliquant un cycle d'oeuvre de 36 heures, couleur vert-jaune.

#### Couchtisch

Gestell aus frostfestem und wetter-beständigem Feinsteinzeug, doppelte, dickenkontrollierte Handglasur, über 36 Stunden bei 1250 °C gebrannt, Farbe grün-gelb.

#### Mesita

Estructura de gres fino porcelánico antihielo para uso exterior, con doble capa de esmalte a mano de espesor controlado, cocido a 1250°C con un ciclo de elaboración de 36 horas, color verde-amarillo.

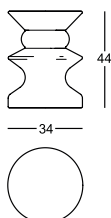



Design

Todd Bracher

2005

**Tavolino**

Struttura in polipropilene, laccatura lucida nei colori della cartella.

**Small table**

Polypropylene frame and glossy lacquer finish in the colours shown on our colour card.

**Petite table**

Structure en polypropylène, laquage brillant dans les couleurs de la fiche.

**Tischchen**

Gestell aus Polypropylen, glanzlackiert in den Farben der Musterkarte.

**Mesita**

Estructura de polipropileno, lacado brillante en los colores del muestrario.

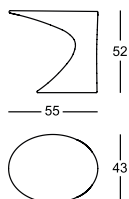

Struttura/Frame/Structure/Gestell/Estructura





Design

Salvatore Indriolo

2012

#### Tavolino

Struttura in poliuretano rigido. Piano in multistrato placcato alluminio. Verniciatura nei colori bianco, nero o rosso. Il piano superiore ruotando a 360° permette l'accesso ad un vano portaoggetti sottostante.

#### Small table

Stiff polyurethane frame. Aluminum-covered plywood top. Varnish in black, white or red. Organizer compartment revealed by rotating tabletop 360°.

#### Petite table

Structure en polyurethane rigide. Plateau en multicouche plaqué aluminium. Peinture en blanche, noire ou rouge. Le plateau supérieur tourne à 360° et permet ainsi d'accéder à un espace porte-objets situé dessous.

#### Couchtisch

Gestell aus steifem Polyurethan. Furnierholzplatte mit Aluminium beschichtet. Lackierung in den Farben weiß, schwarz oder rot. Die Platte lässt sich über einem darunterliegenden Staufach um 360° drehen.

#### Mesita

Estructura de poliuretano rígido. Sobre en multicapa chapado de aluminio. Lacado en color blanco, negro o rojo. Girando 360° el sobre superior se accede a un compartimento portaobjetos inferior.

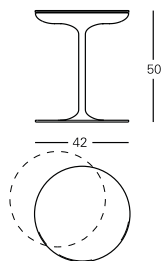

Struttura/Frame/Structure/Gestell/Estructura





Design

Bertrand Lejoly

2022

### Tavolini

Struttura in acciaio verniciato colore nero opaco. Piani in lamiera di acciaio rivestiti in cuoio pigmentato 90 nei colori gold, nero, antracite e fango in abbinamento al piede in faggio laccato colore nero lucido, oppure piani in marmo bianco di Carrara o verde Alpi, in abbinamento rispettivamente al piede in faggio laccato colore bianco lucido RAL 9010 o verde lucido RAL 6012.

### Coffee tables

Matt black varnished steel frame. Steel sheet tops, covered with cowhide pigmentato 90 in the shades gold, black, anthracite and mud matching the foot in glossy black painted beech; or tops made of white Carrara or green Alpi marbles, matching the foot respectively in glossy white RAL 9010 painted or glossy green RAL 6012 painted beech.

### Petites tables

Structure en acier verni noir mat. Plateaux en tôle d'acier recouverts de cuir sellier pigmentato 90 dans les couleurs gold, noir, anthracite et boue en combinaison avec le pied en hêtre laqué noir brillant, ou plateaux en marbre blanc de Carrare ou Alpi vert, en combinaison respectivement avec le pied en hêtre laqué blanc brillant RAL 9010 ou vert brillant RAL 6012.

### Beistelltische

Stahlgestell schwarz matt lackiert. Platten aus Stahlblech, bezogen mit Kernleder pigmentato 90 in den Farben gold, schwarz, anthrazit und Schlamm, passend zum Fuß aus glänzend schwarz lackiertem Eschenholz; oder Platten aus weißem Carrara-Marmor oder grünem Alpi-Marmor, passend zum Fuß bzw. aus glänzend weiß RAL 9010 - oder glänzend grün RAL 6012 lackiertem Eschenholz.

### Mesitas

Estructura en acero pintado en negro mate. Sobres en chapa de acero recubiertas de cuero pigmentato 90 en los colores gold, negro, antracita y barro en combinación con el pie en haya lacada en negro brillante, o sobres en mármol blanco de Carrara o Alpi verde, en combinación respectivamente con el pie en haya lacada en blanco brillante RAL 9010 o verde brillante RAL 6012.

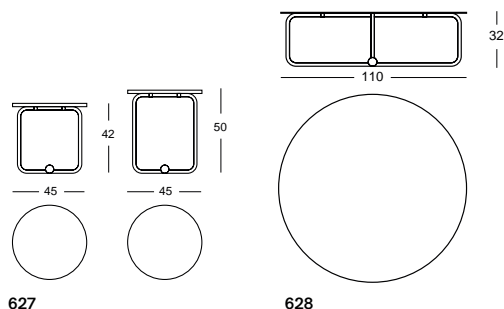

### Piani/Tops/Plateaux/Platten/Sobres



Marmo di Carrara/Carrara marble/  
Marbre de Carrare/Carrara Marmor/  
Mármol de Carrara

Marmo Alpi/Alpi marble/Marbre  
Alpi/Alpi Marmor/ Mármol Alpi



627

628

# Tweed Mini <sup>662</sup>



Design

Garcia Cumini

2021

## Tavolini

Piano in legno placcato in rovere verniciato colore naturale, o a poro aperto colore nero, oppure laccato in noce Canaletto. Sotto piano verniciato colore nero. Gambe in tubolare di acciaio verniciato colore nero opaco.

## Small tables

Top available either in natural painted oak veneered wood, or black painted with open pore, or in Canaletto walnut veneered wood. Black painted under-top. Legs in tubular stainless steel, matt black painted.

## Petites tables

Plateau en bois plaqué en rouvre verni couleur naturel, ou verni à pore ouvert de couleur noire, ou plaqué en noyer Canaletto. Le plateau au-dessous est verni couleur noire. Pieds en acier tubulaire vernis couleur noir mat.

## Beistelltische

Holzplatte furniert mit naturfarben lackierter Eiche, oder schwarz lasiert, oder mit Nussbaum Canaletto. Schwarz lackierte Unterplatte. Beine aus matten schwarz- lackierten Stahlrohr.

## Mesitas

Superficie de madera chapado en roble barnizado natural, o pintado a poro abierto en color negro, o chapado en nogal Canaletto. La parte inferior del sobre es pintado de color negro. Patas en acero tubular pintado de color negro mate.

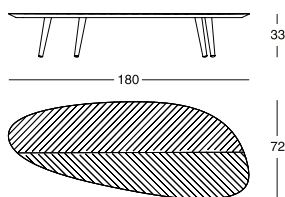
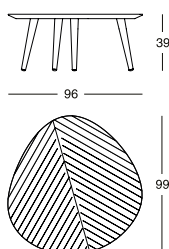
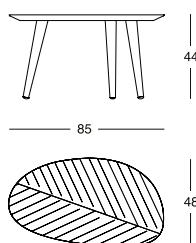

## Piani/Tops/Plateaux/Platten/Sobres

Rovere naturale/  
Natural oakwood/  
Rouvre naturel/  
Naturfarbene  
Eiche/Roble  
natural

Rovere tinto nero/  
Black varnished  
oak/Rouvre teinté  
noir/Schwarz-  
gebeizte Eiche/  
Roble teñido  
negro

Noce Canaletto/  
Canaletto walnut/  
Noyer Canaletto/  
Nussbaum  
Canaletto/Nogal  
Canaletto







Design

Prospero Rasulo

2006

IN/OUT

**Tavolino**

Struttura in gres fine porcellanato antigelivo per esterni, con doppia smaltatura manuale a spessore controllato, cotto a 1250°C con un ciclo di lavorazione di 36 ore, colore blu-marrone.

**Occasional table**

Freeze resistant frame in fine porcelainized grès for outdoors use with thickness controlled two-layering applied by hand and baked at 1250°C with a 36-hour processing cycle, colour blue brown.

**Petite table**

Structure en grès fin émaillé résistante au gel pour externes, avec double émaillage manuel à épaisseur contrôlée, cuit à 1250°C en appliquant un cycle d'oeuvre de 36 heures, couleur bleu-brun.

**Couchtisch**

Gestell aus frostfestem und wetter-beständigem Feinsteinzeug, doppelte, dickenkontrollierte Handglasur, über 36 Stunden bei 1250 °C gebrannt, Farbe blau-braun.

**Mesita**

Estructura de gres fino porcelánico antihielo para uso exterior, con doble capa de esmalte a mano de espesor controlado, cocido a 1250°C con un ciclo de elaboración de 36 horas, color azul-marrón.

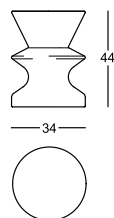



*Sedie*  
Chairs  
*Chaises*  
Stühle  
*Sillas*

106–131



Design

Gae Aulenti

1964

IN/OUT

**Sedia pieghevole**

Struttura in acciaio inox.  
Snodi in lega di alluminio.  
Rivestimento sfilabile in Vip  
(per esterni), in Telastrong o  
in cuoio 95.

**Folding chair**

Stainless steel frame.  
Aluminum alloy joints.  
Removable cover in Vip (for  
outdoors), in Telastrong, or in  
cowhide 95.

**Chaise pliante**

Structure en acier inox.  
Articulations en alliage  
d'aluminium. Revêtement  
déhoussable en Vip (pour  
extérieurs), en Telastrong, ou  
en cuir sellier 95.

**Klappsessel**

Gestell aus Inox-  
Stahl. Gelenke aus  
Aluminiumlegierung.  
Abnehmbarer Bezug aus Vip  
(fürs Freie), aus Telastrong,  
oder aus Kernleder 95.

**Silla plegable**

Estructura de acero inox.  
Articulaciones de aleación  
de aluminio. Tapizado  
desenfundable de Vip (para  
exteriores), de Telastrong, o  
de cuero 95.

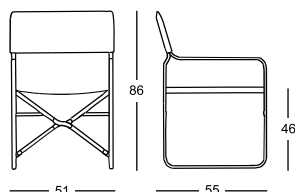

# Celestina <sup>2260</sup>



Design

Marco Zanuso

1978

**Sedia pieghevole**

Struttura in acciaio verniciato, colore nero o bianco. Sedile e schienale in nylon ricoperti in cuoio 95.

**Folding chair**

Frame in black or white painted steel. Nylon seat and back covered in cowhide 95.

**Chaise pliante**

Structure en acier verni noir ou blanc. Assise et dossier en nylon recouverts de cuir sellier 95.

**Klappstuhl**

Gestell aus lackiertem Stahl, schwarz oder weiß. Sitzfläche und Rückenlehne aus Nylon mit Kernleder 95 bezogen.

**Silla plegable**

Estructura de acero pintado en los colores: negro o blanco. Asiento y respaldo de nylon tapizados de cuero 95.

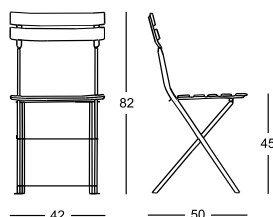

Struttura/Frame/Structure/ Gestell/Estructura





Design

Patrick Norguet

2020

**Sedia con o senza braccioli**

Struttura in acciaio verniciato colore grigio ferro o nero opaco. Seduta e schienale realizzati con nastri elastici in filato di poliestere nei colori giallo, corda, antracite e blu. Il logo Zanotta è stampato sulla

prima cinghia della seduta e collocato sul lato destro. A richiesta è disponibile la personalizzazione di stampa delle cinghie.

**Chair with or without armrests**

Steel frame varnished iron grey or matt black. Seat and backrest made of elastic straps in polyester thread available in yellow, string, anthracite and blue. The Zanotta logo is printed on the

first strap of the seat, on the right side. Upon request the customized writing on the straps is available.

**Chaise avec ou sans accoudoirs**

Structure en acier verni gris fer ou noir mat. Assise et dossier réalisés avec des rubans élastiques en fil de polyester dans les couleurs jaune, corde, anthracite et bleu. Le logo Zanotta est

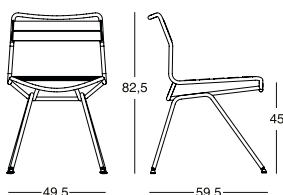

2057

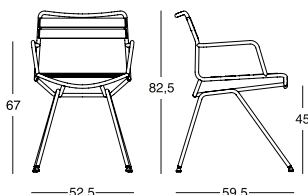

2058



imprimé sur le premier ruban d'assise sur le côté droit. Sur demande est disponible une personnalisation de la presse des sangles.

**Stuhl mit oder ohne Armlehnen**  
Gestell aus eisengrauem oder mattem schwarz-lackierten Stahl. Sitz und Rückenlehne bestehen aus Gummibändern in Polyestergerne in den Farben Gelb, Schnur, anthrazit und

blau. Das Zanotta Logo ist auf das erste Band des Sitzens, an der rechten Seite, gedruckt. Auf Nachfrage können die Aufschriften auf die Bänder personalisiert werden.

**Silla con o sin apoyabrazos**  
Estructura de acero pintado en los colores gris hierro o negro mate. Asiento y respaldo realizados con cintas elásticas de poliéster en los colores amarillo, cuerda, antracita y azul. El

logo Zanotta está impreso en la primera cinta del asiento, y colocado en el lado derecho. Sobre pedido es disponible la personalización de la impresión de las cintas.

Struttura/Frame/Structure/ Gestell/Estructura



Seduta/Seat/Siège/Sitz/Asiento



# Dan <sup>2059</sup>



Design

Patrick Norguet

2020

## Sedia

Struttura in acciaio verniciato colore grigio ferro o nero opaco. Seduta e schienale imbottiti in poliuretano. Rivestimento non sfilabile in cuoio 95.

## Chair

Steel frame varnished iron grey or matt black. Seat and backrest upholstered with polyurethane. Non removable cover in cowhide 95.

## Chaise

Structure en acier verni gris fer ou noir mat. Siège et dossier rembourrés en polyuréthane. Revêtement pas déhoussable en cuir sellier 95.

## Stuhl

Gestell aus eisengrauem oder mattem schwarz-lackierten Stahl. Sitz und Rückenlehne gepolstert mit Polyurethan. Nicht abnehmbarer Bezug aus Kernleder 95.

## Silla

Estructura de acero pintado en los colores gris hierro o negro mate. Asiento y respaldo acolchados de poliuretano. Tapizado no desenfundable de cuero.

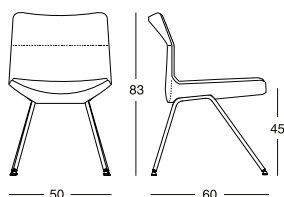

Struttura/Frame/Structure/ Gestell/Estructura





# Dan outdoor 2073/2074



Design

Patrick Norguet

2020

IN/OUT

## Sedia per esterni con o senza braccioli

Struttura in acciaio verniciato per esterno colore grigio ferro o nero opaco. Seduta e schienale realizzati con nastri elastici in filato di poliestere nei colori giallo, corda, antracite e blu. Il logo Zanotta è stampato sulla prima cinghia della seduta e collocato sul lato destro. A richiesta è disponibile la personalizzazione di stampa delle cinghie.

## Outdoor chair with or without armrests

Steel frame varnished for outdoor iron grey or matt black. Seat and backrest made of elastic straps in polyester thread available in yellow, string, anthracite and blue. The Zanotta logo is printed on the first strap of the seat, on the right side. Upon request the customized writing on the straps is available.

## Chaise pour extérieur avec ou sans accoudoirs

Structure en acier verni gris fer ou noir mat pour extérieur. Assise et dossier réalisés avec des rubans élastiques en fil de polyester dans les couleurs jaune, corde, anthracite et bleu. Le logo Zanotta est imprimé sur le premier ruban d'assise sur le côté droit. Sur demande est disponible une personnalisation de la presse des sangles.

## Stuhl fürs Freie mit oder ohne Armlehnen

Gestell aus fürs Freie eisengrauem oder mattem schwarz-lackierten Stahl. Sitz und Rückenlehne bestehen aus Gummibändern in Polyesterfarn in den Farben Gelb, Schnur, anthrazit und blau. Das Zanotta Logo ist auf das erste Band des Sitzens, an der rechten Seite, gedruckt. Auf Nachfrage können die Aufschriften auf die Bänder personalisiert werden.

## Silla para exteriores con o sin apoyabrazos

Estructura de acero pintado en los colores gris hierro o negro mate para exteriores. Asiento y respaldo realizados con cintas elásticas de poliéster en los colores amarillo, cuerda, antracita y azul. El logo Zanotta está impreso en la primera cinta del asiento, y colocado en el lado derecho. Sobre pedido es disponible la personalización de la impresión de las cintas.

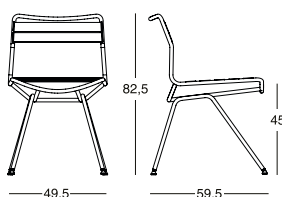

2073

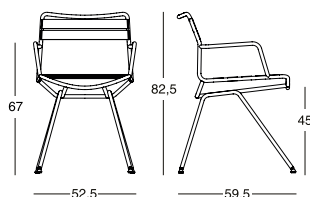

2074

Struttura/Frame/Structure/ Gestell/Estructura



Seduta/Seat/Siège/Sitz/Asiento



# Daisy<sup>2125</sup>



Design

Mist-o

2023

**Sedia sovrapponibile**

Gambe in lega di alluminio verniciato colore nero o bianco opaco. Sedile in multistrato con imbottitura in poliuretano schiumato autoestinguente. Struttura

schienale in acciaio con imbottitura in poliuretano schiumato autoestinguente. Rivestimento sfilabile in stoffa o in pelle.

**Stackable chair**

Aluminum alloy legs painted matt black or white. Plywood seat with self-extinguishing polyurethane foam upholstery. Steel backrest frame with self-extinguishing

polyurethane foam upholstery. Removable cover in fabric or leather.

**Chaise superposable**

Pieds en alliage d'aluminium verni, couleur noir ou blanc mat. Siège en multicouche avec rembourrage en mousse de polyuréthane autoextinguible. Structure

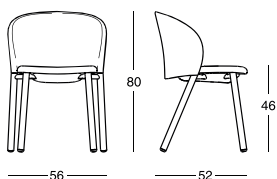



dossier en acier avec rembourrage en mousse de polyuréthane autoextinguible. Revêtement déhoussable en tissu ou en cuir.

**Stapelbarer Stuhl**  
Beine aus weiß oder schwarz matt lackierter Alu-Legierung. Sitz aus Sperrholz mit selbstlöschendem Polyurethanschaum gepolstert. Rückenlehne aus

Stahl mit selbstlöschendem Polyurethanschaum gepolstert. Abnehmbarer Bezug aus Stoff oder Leder.

**Silla apilable**  
Patas de aleación de aluminio pintado negro o blanco mate. Asiento de madera contrachapada con acolchado de espuma de poliuretano autoextintivo.

Respaldo de acero con acolchado de espuma de poliuretano autoextintivo. Tapizado desenfundable de tejido o piel.

Gambe/Legs/Pieds/Beine/Patas



# Fenis CM<sup>2051</sup>



Omaggio a

Carlo Mollino

1959

## Sedia

Struttura in legno massello di acero verniciato colore naturale o nero.

## Chair

Frame in natural or black painted solid maple wood.

## Chaise

Structure en érable massif verni couleur naturel ou noir.

## Stuhl

Gestell aus massivem Ahornholz, naturfarben oder schwarz lackiert.

## Silla

Estructura de madera de arce maciza con acabado en color natural o negro.

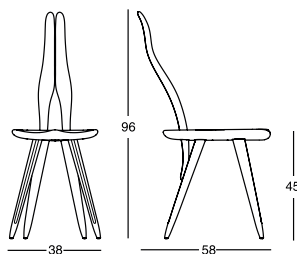

Struttura/Frame/Structure/ Gestell/Estructura





Design

Frank Rettenbacher

2016

### Sgabelli

Struttura in legno massello di rovere o noce Canaletto verniciati, colore naturale. Poggiapiedi in acciaio inox satinato.

### Stools

Frame in solid oak or Canaletto walnut, natural painted. Footrest in satin-finished stainless steel.

### Tabourets

Structure en bois massif de rouvre ou noyer Canaletto, vernis naturel. Appui-pieds en acier inox satiné.

### Hocker

Gestell aus Massivholz in Eiche oder Nussbaum Canaletto, beide naturfarben lackiert. Fußstütze aus satiniertem Stahl.

### Taburetes

Estructura de madera maciza de roble o nogal Canaletto, barnizados natural. Reposapiés de acero inox satinado.

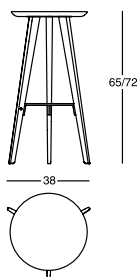

2286/A 38 x 72 cm  
2286/B 38 x 65 cm

Rovere naturale/Natural oakwood/Rouvre naturel/Naturfarbene Eiche/Roble natural



Noce Canaletto/Canaletto walnut/Noyer Canaletto/Nussbaum Canaletto/Nogal Canaletto





Design

Roberto Barbieri

2003

#### Sedia

##### Sedia con braccioli

Struttura in lega di alluminio. Sedile, schienale e braccioli imbottiti in poliuretano. Rivestimento sfilabile in stoffa o in pelle oppure non sfilabile in cuoio. A richiesta viene fornita una fodera coprisedia da calzare senza fissare: in tessuto 100% cotone, colore bianco, disponibile sia corta che ricopre sedile e schienale, sia lunga che ricopre anche le gambe.

#### Chair

##### Chair with armrests

Aluminium alloy frame. Seat, back and armrests upholstered in polyurethane. Removable cover in fabric or leather or non-removable in cowhide. Upon request one loose cover to be put on without fixing can be supplied: in 100% white cotton, available either short covering seat and backrest or long covering legs too.

#### Chaise

##### Chaise avec accoudoirs

Structure en alliage d'aluminium. Siège, dossier et accoudoirs rembourrés en polyuréthane. Revêtement déhoussable en tissu ou en cuir ou pas déhoussable en cuir sellier. Sur demande on peut fournir une housse à poser sans la fixer pour protéger les chaises : en tissu 100% coton, couleur blanche, dans les versions courte qui couvre assise et dossier ou longue qui couvre même les pieds.

#### Stuhl

##### Stuhl mit Armlehnen

Gestell aus Alu-Legierung. Sitz, Rückenlehne und Armlehnen Polyurethan-gepolstert. Abnehmbarer Bezug aus Stoff oder Leder oder aus nicht abnehmbarem Kernleder. Auf Nachfrage ist ein loser Bezug verfügbar, der auf dem Stuhl ohne befestigen anzuziehen ist: aus 100% weißer Baumwolle, in zwei Versionen lieferbar, kurz, der Sitz und Rücken überzieht, oder lang, der auch die Beine überzieht.

#### Silla

##### Silla con apoyabrazos

Estructura de aleación de aluminio. Asiento, respaldo y apoyabrazos acolchados en poliuretano. Tapizado desenfundable de tejido o de piel o no desenfundable de cuero. A pedido suministramos una funda de poner sobre la silla sin fijarla: de tejido 100% algodón, color blanco, disponible corta que cubre asiento y respaldo o larga que cubre también las patas.

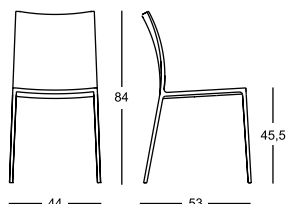

2083

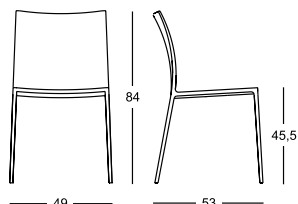

2084

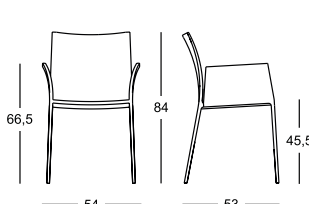

2085

# Lealta <sup>2081</sup>



Design

Roberto Barbieri

2006

## Sedia

Struttura in lega di alluminio. Sedile e schienale imbottiti in poliuretano. Rivestimento sfilabile in stoffa o in pelle oppure non sfilabile in cuoio. A richiesta viene fornita una fodera coprisedia da calzare senza fissare: in tessuto 100% cotone, colore bianco, disponibile sia corta che ricopre sedile e schienale, sia lunga che ricopre anche le gambe.

## Chair

Aluminium alloy frame. Seat and back upholstered in polyurethane. Removable cover in fabric or leather or non-removable in cowhide. Upon request one loose cover to be put on without fixing can be supplied: in 100% white cotton, available either short covering seat and backrest or long covering legs too.

## Chaise

Structure en alliage d'aluminium. Siège et dossier rembourrés en polyuréthane. Revêtement déhoussable en tissu ou en cuir ou pas déhoussable en cuir sellier. Sur demande on peut fournir une housse à poser sans la fixer pour protéger les chaises: en tissu 100% coton, couleur blanche, dans les versions courte qui couvre assise et dossier ou longue qui couvre même les pieds.

## Stuhl

Gestell aus Aluminiumlegierung. Sitz und Rückenlehne Polyurethangepolstert. Abnehmbarer Bezug aus Stoff oder Leder oder aus nicht abnehmbarem Kernleder. Auf Nachfrage ist ein loser Bezug verfügbar, der auf dem Stuhl ohne befestigen anzuziehen ist: aus 100% weißer Baumwolle, in zwei Versionen lieferbar, kurz, der Sitz und Rücken überzieht, oder lang, der auch die Beine überzieht.

## Silla

Estructura de aleación de aluminio. Asiento y respaldo acolchados en poliuretano. Tapizado desenfundable de tejido o de piel o no desenfundable de cuero. A pedido suministramos una funda de poner sobre la silla sin fijarla: de tejido 100% algodón, color blanco, disponible corta que cubre asiento y respaldo o larga que cubre también las patas.

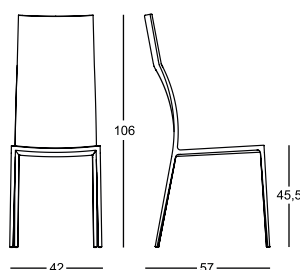



Design

Roberto Barbieri

1998-1999

## Sedia

### Sedia con braccioli

Struttura in lega di alluminio lucidato oppure verniciato, colore nero, grafite o bianco. Sedile, schienale e braccioli imbottiti in poliuretano. Rivestimento sfilabile in stoffa o in pelle oppure non sfilabile in cuoio. A richiesta viene fornita una fodera coprisedia da calzare senza fissare: in tessuto 100% cotone, colore bianco, disponibile sia corta che ricopre sedile e schienale, sia lunga che ricopre anche le gambe.

## Chaise

### Chair with armrests

Aluminum alloy frame, polished or painted black, graphite or white. Seat, back and armrests upholstered in polyurethane. Removable cover in fabric or leather or non-removable in cowhide. Upon request one loose cover to be put on without fixing can be supplied: in 100% white cotton, available either short covering seat and backrest or long covering legs too.

## Chaise

### Chaise avec accoudoirs

Structure en alliage d'aluminium poli ou verni, couleur noir, graphite ou blanc. Siège, dossier et accoudoirs rembourrés en polyuréthane. Revêtement déhoussable en tissu ou en cuir ou pas déhoussable en cuir sellier. Sur demande on peut fournir une housse à poser sans la fixer pour protéger les chaises: en tissu 100% coton, couleur blanche, dans les versions courte qui couvre assise et dossier ou longue qui couvre même les pieds.

## Stuhl

### Stuhl mit Armlehnen

Gestell aus polierter Aluminiumlegierung oder schwarz, graphit oder weiß lackiert. Sitz, Rückenlehne und Armlehnen Polyurethan-gepolstert. Abnehmbarer Bezug aus Stoff oder Leder oder aus nicht abnehmbarem Kernleder. Auf Nachfrage ist ein loser Bezug verfügbar, der auf dem Stuhl ohne befestigen anzuziehen ist: aus 100% weißer Baumwolle, in zwei Versionen lieferbar, kurz, der Sitz und Rücken überzieht, oder lang, der auch die Beine überzieht.

## Silla

### Silla con apoyabrazos

Estructura de aleación de aluminio pulido o pintado de color negro, grafito o blanco. Asiento, respaldo y apoyabrazos acolchados en poliuretano. Tapizado desenfundable de tejido o de piel o no desenfundable de cuero. A pedido suministramos una funda de poner sobre la silla sin fijarla: de tejido 100% algodón, color blanco, disponible corta que cubre asiento y respaldo o larga que cubre también las patas.

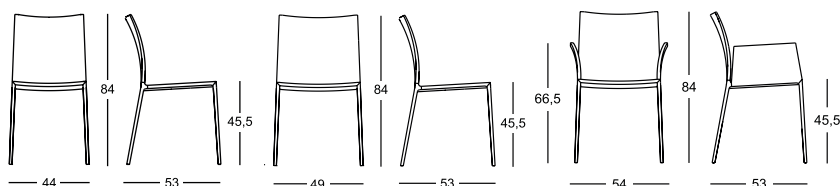

2086

2087

2088

Struttura/Frame/Structure/ Gestell/Estructura





# Lialta <sup>2082</sup>



Design

Roberto Barbieri

2006

## Sedia

Struttura in lega di alluminio lucidato oppure verniciato colore nero, grafite o bianco. Sedile e schienale imbottiti in poliuretano. Rivestimento sfilabile in stoffa o in pelle oppure non sfilabile in cuoio. A richiesta viene fornita una fodera copriesedia da calzare senza fissare: in tessuto 100% cotone, colore bianco, disponibile sia corta che ricopre sedile e schienale, sia lunga che ricopre anche le gambe.

## Chair

Aluminum alloy frame, polished or painted black, graphite or white. Seat and back upholstered in polyurethane. Removable cover in fabric or leather or non-removable in cowhide. Upon request one loose cover to be put on without fixing can be supplied: in 100% white cotton, available either short covering seat and backrest or long covering legs too.

## Chaise

Structure en alliage d'aluminium poli ou verni, couleur noir, graphite ou blanc. Siège et dossier rembourrés en polyuréthane. Revêtement déhoussable en tissu ou en cuir ou pas déhoussable en cuir sellier. Sur demande on peut fournir une housse à poser sans la fixer pour protéger les chaises: en tissu 100% coton, couleur blanche, dans les versions courte qui couvre assise et dossier ou longue qui couvre même les pieds.

## Stuhl

Gestell aus polierter Aluminiumlegierung oder schwarz, Graphit oder weiß lackiert. Sitz und Rückenlehne Polyurethangepolstert. Abnehmbarer Bezug aus Stoff oder Leder oder aus nicht abnehmbarem Kernleder. Auf Nachfrage ist ein loser Bezug verfügbar, der auf dem Stuhl ohne befestigen anzuziehen ist: aus 100% weißer Baumwolle, in zwei Versionen lieferbar, kurz, der Sitz und Rücken überzieht, oder lang, der auch die Beine überzieht.

## Silla

Estructura de aleación de aluminio pulido o pintado de color negro, grafito o blanco. Asiento y respaldo acolchados en poliuretano. Tapizado desenfundable de tejido o de piel o no desenfundable de cuero. A pedido suministramos una funda de poner sobre la silla sin fijarla: de tejido 100% algodón, color blanco, disponible corta que cubre asiento y respaldo o larga que cubre también las patas.

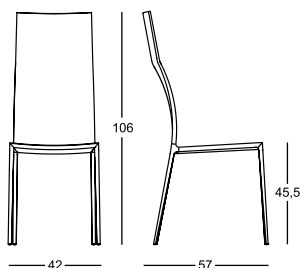

Struttura/Frame/Structure/ Gestell/Estructura



# Lio/Leo 2291/2292



Design

Roberto Barbieri

2005

## Sgabelli

Struttura in lega di alluminio (2292) oppure in lega di alluminio lucidato o verniciato colore nero, grafite o bianco (2291). Sedile e schienale imbottiti in poliuretano. Rivestimento sfilabile in stoffa o in pelle oppure non sfilabile in cuoio. Poggiapiedi

in acciaio inox satinato. A richiesta viene fornita una fodera copri sgabello, in tessuto 100% cotone, colore bianco, da calzare senza fissare, che ricopre sedile e schienale.

## Stools

Frame in aluminum alloy (2292) or in polished aluminum alloy, or painted black, graphite or white (2291). Seat and back with polyurethane upholstery. Removable cover in fabric or leather or non-removable in cowhide. Footrest in satin-

finished stainless steel. Upon request a 100% white cotton loose stool cover to be put on without fixing, covering seat and backrest, can be supplied.

## Tabourets

Structure en alliage d'aluminium (2292) ou en alliage d'aluminium poli, ou verni couleur noir, graphite ou blanche (2291). Assise et dossier rembourrés en polyuréthane. Revêtement déhoussable en tissu ou en cuir ou pas déhoussable en

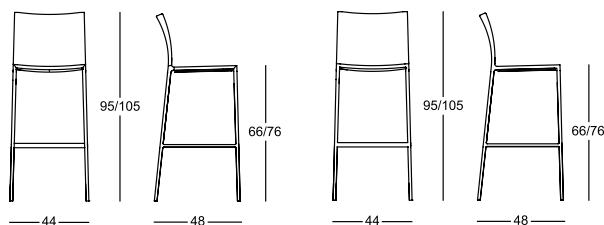

2291/A h 76 cm / 2291/B h 66 cm

2292/A h 76 cm / 2292/B h 66 cm



cuir sellier. Appuie-pieds en acier inox satiné. Sur demande on va fournir une housse qui protège le tabouret en tissu 100% coton, couleur blanche, de poser sans la fixer, qui couvre assise et dossier.

**Hocker**  
Gestell aus Aluminiumlegierung (2292) oder aus polierter Aluminiumlegierung, oder schwarz, Graphit oder weiß lackiert (2291). Sitz und Rückenlehne mit Polsterung aus Polyurethan. Abnehmbarer Außenbezug

aus Stoff oder Leder oder aus nicht abnehmbarem Kernleder. Fußstütze aus satiniertem Edelstahl. Auf Nachfrage ist ein loser Bezug aus 100% weißer Baumwolle lieferbar, der auf dem Hocker ohne Befestigen anzuziehen ist und Sitz und Rücken überzieht.

**Taburetes**  
Estructura de aleacion de aluminio (2292) o de aleacion de aluminio pulido o barnizado color negro, grafito o blanco (2291). Asiento y respaldo acolchados de poliuretano. Tapizado desenfundable de tejido o de piel o no desenfundable de

cuero. Reposapiés de acero inoxidable satinado. A pedido suministramos una funda que protege el taburete de tejido 100% algodón, color blanco, de poner sobre el taburete sin fijarla, que cubre asiento y respaldo.

Struttura/Frame/Structure/ Gestell/Estructura (mod. 2291)



# Liza 2271/R



Design

Lievore, Altherr, Molina

2015

## Poltroncina

Gambe in legno massello di rovere verniciato, colore naturale, o tinto nero o in noce Canaletto colore naturale. Scocca con braccioli in polipropilene caricato fibra di vetro, colore bianco o nero. Imbottitura cuscino seduta in poliuretano. Rivestimento cuscino seduta sfilabile in stoffa o in pelle. Rivestimento schienale sfoderabile in stoffa o pelle accoppiato a Dacron Du Pont.

## Armchair

Legs in solid natural or black painted oak or in natural Canaletto walnut. Sling with armrests of polypropylene reinforced with glass fibre, in the shades white or black. Seat cushion upholstered with polyurethane. Removable cover of the seat cushion in fabric or leather. Removable backrest cover in fabric or leather with Dacron Du Pont.

## Petit fauteuil

Pieds en bois massif rouvre verni naturel, ou teinté noir ou en noyer Canaletto, couleur naturelle. Coque avec accoudoirs en polypropylène, renforcée de fibres de verre, dans les couleurs blanche ou noire. Rembourrage coussin assise en polyuréthane. Revêtement coussin assise déhoussable en tissu ou cuir. Revêtement dossier déhoussable en tissu ou cuir, couplé à Dacron Du Pont.

## Kleiner Sessel

Beine aus massiver Eiche, naturfarben oder schwarz lackiert, oder aus naturfarbenem Nussbaum Canaletto. Sitzschale mit Armlehnen aus Polypropylen mit Glasfaser verstärkt, in den Farben weiß oder schwarz. Sitzkissen-Polsterung aus Polyhurethan. Sitzkissen mit abnehmbarem Bezug aus Stoff oder Leder. Abnehmbarer Bezug der Rückenlehne aus Stoff oder Leder, mit Dacron Du Pont gekoppelt.

## Butaquita

Patatas de madera maciza de roble, pintado color natural o teñido negro, o de nogal Canaletto color natural. Armazón con apoyabrazos de polipropileno reforzado con fibra de vidrio, color blanco o negro. Cojín asiento acolchado de poliuretano. Cojín asiento con tapizado desenfundable, de tejido o de piel. Tapizado del respaldo, desenfundable, de tejido o de piel acoplado con Dacron Du Pont.

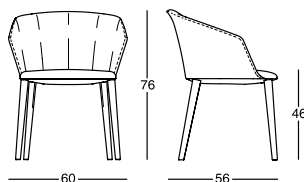

### Gambe/Legs/Pieds/Beine/Patas

Rovere naturale/Natural oakwood/Rouvre naturel/  
Naturfarbene Eiche/  
Roble natural



Rovere tinto nero/Black varnished oak/ Rouvre teinté noir/Schwarz-gebeizte Eiche/ Roble teñido negro



Noce Canaletto/Canaletto walnut/Noyer Canaletto/  
Nussbaum Canaletto/  
Nogal Canaletto



### Scocca/Sling/Coque/Sitzschale/Armazón





Design

Alfredo Häberli

2003

### Poltroncina girevole e reclinabile

Base a cinque razze in lega di alluminio lucidato con rotelle o con piedini (2278/P). Altezza seduta regolabile. Schienale reclinabile, con comando, fissabile in cinque posizioni diverse o oscillante in maniera continua. Imbottitura in poliuretano con molleggio su nastri elastici. Cuscino seduta, a richiesta, in poliuretano/Dacron Du Pont. Rivestimento sfilabile in stoffa o in pelle.

### Reclining swivel armchair

Five-spoke base in polished aluminum alloy with castors or feet (2278/P). Adjustable seat height. The tilting back, with controls, can be set in five different positions or made to constantly rock. Polyurethane upholstery with elastic strips suspension. Seat cushion in polyurethane/Dacron Du Pont, on request. Removable fabric or leather cover.

### Petit fauteuil tournant et inclinable

Base à cinq rayons en alliage d'aluminium poli à roulettes ou pieds (2278/P). Hauteur du siège réglable. Le dossier inclinable par commande peut être fixé dans cinq positions différentes ou basculer de manière continue. Rembourrage en polyuréthane avec suspension sur sangles élastiques. Sur demande, coussin du siège en polyuréthane/Dacron Du Pont. Revêtement déhoussable en tissu ou en cuir.

### Verstellbarer Drehsessel

Fünfbeiniger Fuß aus polierter Aluminiumlegierung auf Rollen oder mit festen Füßen (2278/P). Sitzhöhe regulierbar. Neigung der Lehne über Mechanismus verstellbar, in fünf Positionen zu fixieren oder stufenlos beweglich. Polsterung aus Polyurethan mit Federung auf elastischen Gurten. Auf Wunsch Sitzkissen aus Polyurethan/Dacron Du Pont. Abnehmbarer Bezug aus Stoff oder Leder.

### Sillón giratorio y reclinable

Base con cinco radios en aleación de aluminio pulido con ruedas o patas (2278/P). Altura del asiento regulable. Respaldo reclinable, mediante control, se puede fijar en cinco posiciones diferentes o oscilar de forma continua. Acolchado de poliuretano con suspensión sobre cintas elásticas. Cojín del asiento, a pedido, en poliuretano/Dacron Du Pont. Tapizado desenfundable de tejido o de piel.

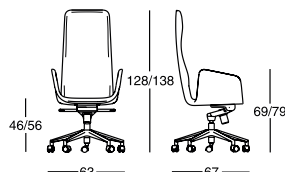
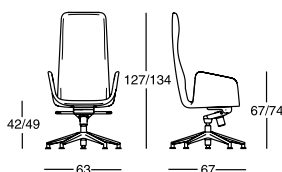

# Nena <sup>2262</sup>



Design

Lanzavecchia+Wai

2020

## Poltroncina

Struttura in acciaio verniciato colore grafite o nero opaco. Imbottitura sedile e schienale in poliuretano. Rivestimento sfilabile in stoffa o in pelle.

## Armchair

Steel frame varnished graphite or matt black. Seat and backrest upholstered with polyurethane. Removable fabric or leather cover.

## Petit fauteuil

Structure en acier verni graphite ou noir mat. Assise et dossier rembourrés en polyuréthane. Revêtement déhoussable en tissu ou en cuir.

## Kleiner Sessel

Gestell aus graphitfarben oder matten schwarz lackierten Stahl. Sitz- und Rückenlehne Polsterung mit Polyurethan gepolstert. Abnehmbarer Bezug aus Stoff oder Leder

## Butaquita

Estructura de acero pintado en los colores grafite o negro mate. Acolchado del asiento y del respaldo en poliuretano. Tapizado desenfundable de tejido o piel.

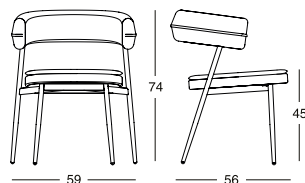

Struttura/Frame/Structure/ Gestell/Estructura



# Nena Stool <sup>2293</sup>



Design

Lanzavecchia+Wai

2022

## Sgabello

Struttura in acciaio verniciato colore grafite o nero opaco. Imbottitura sedile e schienale in poliuretano. Rivestimento sfilabile in stoffa o in pelle. Poggiapiedi ricoperto in acciaio inox satinato.

## Stool

Steel frame varnished graphite or matt black. Seat and backrest upholstered with polyurethane. Removable fabric or leather cover. Footrest covered with satin-finished stainless steel.

## Tabouret

Structure en acier verni graphite ou noir mat. Assise et dossier rembourrés en polyuréthane. Revêtement déhoussable en tissu ou en cuir. Appuie-pieds recouvert en acier inox satiné.

## Hocker

Stahl-Gestell, graphitfarben oder matt schwarz lackiert. Sitz- und Rückenlehne Polsterung mit Polyurethan gepolstert. Abnehmbarer Bezug aus Stoff oder Leder. Fußstütze bezogen mit satiniertem Inox-Stahl.

## Taburete

Estructura de acero pintado en los colores grafite o negro mate. Acolchado del asiento y del respaldo en poliuretano. Tapizado desenfundable de tejido o piel. Reposapiés recubierto de acero inoxidable satinado.

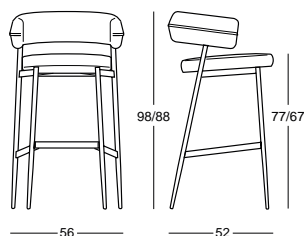

Struttura/Frame/Structure/ Gestell/Estructura



# Talia <sup>2080</sup>



Design

Roberto Barbieri

2007

## Sedia impilabile

Struttura in lega di alluminio lucidato oppure verniciato colore nero, grafite o bianco. Sedile e schienale imbottiti in poliuretano. Rivestimento sfilabile in stoffa o in pelle oppure non sfilabile in cuoio. A richiesta viene fornita una fodera coprisedia da calzare senza fissare: in tessuto 100% cotone, colore bianco, disponibile sia corta che ricopre sedile e schienale, sia lunga che ricopre anche le gambe. A richiesta è disponibile un carrello per il trasporto delle sedie impilate (massimo 15 sedie).

## Stackable chair

Aluminum alloy frame, polished or painted black, graphite or white. Seat and back upholstered in polyurethane. Removable cover in fabric or leather or non-removable in cowhide. Upon request one loose cover to be put on without fixing can be supplied: in 100% white cotton, available either short covering seat and backrest or long covering legs too. Upon request a trolley for carrying the stacked chairs (max 15 chairs) is available.

## Chaise superposable

Structure en alliage d'aluminium poli ou verni, couleur noir, graphite ou blanc. Siège et dossier rembourrés en polyuréthane. Revêtement déhoussable en tissu ou en cuir ou pas déhoussable en cuir sellier. Sur demande on peut fournir une housse à poser sans la fixer pour protéger les chaises: en tissu 100% coton, couleur blanche, dans les versions courte qui couvre assise et dossier ou longue qui couvre même les pieds. Sur demande est disponible aussi un chariot pour déplacer les chaises superposées (maximum 15 chaises).

## Stapelbarer Stuhl

Gestell aus polierter Aluminiumlegierung oder Graphit, schwarz oder weiß lackiert. Sitz und Rückenlehne Polyurethan-gepolstert. Abnehmbarer Bezug aus Stoff oder Leder oder aus nicht abnehmbarem Kernleder. Auf Nachfrage ist ein loser Bezug verfügbar, der auf dem Stuhl ohne befestigen anzuziehen ist: aus 100% weißer Baumwolle, in zwei Versionen lieferbar, kurz, der Sitz und Rücken überzieht, oder lang, der auch die Beine überzieht. Auf Nachfrage ist ein Wagen zum Transport der gestapelten Stühle (max 15 Stühle) lieferbar.

## Silla apilable

Estructura de aleación de aluminio pulido o pintado de color negro, grafito o blanco. Asiento y respaldo acolchados en poliuretano. Tapizado desenfundable de tejido o de piel o no desenfundable de cuero. A pedido suministramos una funda de poner sobre la silla sin fijarla: de tejido 100% algodón, color blanco, disponible corta que cubre asiento y respaldo o larga que cubre también las patas. A pedido suministramos un carro para transportar las sillas apiladas (máximo 15 sillas).

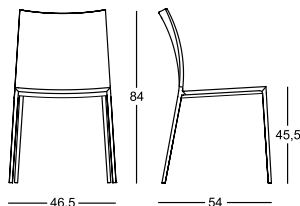

Struttura/Frame/Structure/ Gestell/Estructura





# Tonietta <sup>2090</sup>



Design

Enzo Mari

1985

## Sedia

Struttura in lega di alluminio lucidato o verniciato nero. Sedile e schienale in polipropilene ricoperto in cuoio 95 nei colori della cartella.

## Chair

Polished or black painted aluminum alloy frame. Seat and back in polypropylene covered in cowhide 95 in the colours indicated on our colour card.

## Chaise

Structure en alliage d'aluminium poli ou verni noir. Assise et dossier en polypropylène recouverts en cuir sellier 95 dans les couleurs de la fiche.

## Stuhl

Gestell aus polierter oder schwarz lackierter Aluminiumlegierung. Sitzfläche und Rückenlehne aus Polypropylen mit Kernleder 95 bezogen in den Farben der Musterkarte.

## Silla

Estructura de aleación de aluminio pulido o pintado negro. Asiento y respaldo de polipropileno tapizado con cuero 95 en los colores del muestrario.

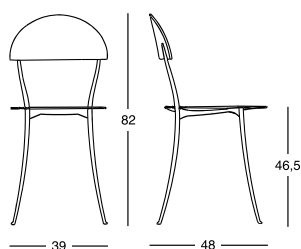

Struttura/Frame/Structure/ Gestell/Estructura



# Tusa High <sup>2261/A</sup>



Design

Rodolfo Dordoni

2019

**Poltroncina  
con schienale alto**

Gambe in acciaio verniciato colore nero. Sedile in multistrato con imbottitura in poliuretano. Struttura schienale in acciaio con imbottitura in poliuretano. Rivestimento sfilabile in stoffa o in pelle. Disponibile anche la versione con sedile in pelle 95 e schienale in tessuto cat. 30.

**Armchair  
with high backrest**

Legs in black painted steel. Plywood seat upholstered with polyurethane. Steel backrest with polyurethane upholstery. Removable fabric or leather cover. The version with leather 95 covered seat cushion and backrest in fabric cat. 30 is also available.

**Fauteuil avec dossier haut**

Pieds en acier verni noir. Assise en contreplaqué et rembourrée en polyuréthane. Structure du dossier en acier avec rembourrage en polyuréthane. Revêtement déhoussable en tissu ou en cuir. La version avec siège revêtu en cuir 95 et dossier en tissu cat. 30 est aussi disponible.

**Sessel mit hoher  
Rückenlehne**

Beine aus schwarz lackiertem Stahl. Sitz aus Sperrholz mit Polsterung aus Polyurethan. Rückenlehne aus Stahl mit Polsterung aus Polyurethan. Abnehmbarer Bezug aus Stoff oder Leder. Die Ausführung mit Sitzkissen aus Leder 95 und Rückenlehne mit Stoff Kat. 30 ist auch verfügbar.

**Butaquita  
con respaldo alto**

Patas de acero pintado negro. Asiento en contrachapado y acolchado con poliuretano. Estructura del respaldo en acero acolchado de poliuretano. Tapizado desenfundable de tejido o de piel. Existe también una versión con asiento en piel 95 y respaldo en tejido cat. 30.

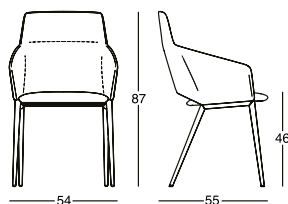

# Tusa Low <sup>2261/B</sup>



Design

Rodolfo Dordoni

2019

**Poltroncina  
con schienale basso**

Gambe in acciaio verniciato colore nero. Sedile in multistrato con imbottitura in poliuretano. Struttura schienale in acciaio con imbottitura in poliuretano. Rivestimento sfilabile in stoffa o in pelle. Disponibile anche la versione con sedile in pelle 95 e schienale in tessuto cat. 30.

**Armchair  
with low backrest**

Legs in black painted steel. Plywood seat upholstered with polyurethane. Steel backrest with polyurethane upholstery. Removable fabric or leather cover. The version with leather 95 covered seat cushion and backrest in fabric cat. 30 is also available.

**Fauteuil avec dossier bas**

Pieds en acier verni noir. Assise en contreplaqué et rembourrée en polyuréthane. Structure du dossier en acier avec rembourrage en polyuréthane. Revêtement déhoussable en tissu ou en cuir. La version avec siège revêtu en cuir 95 et dossier en tissu cat. 30 est aussi disponible.

**Sessel mit niedriger  
Rückenlehne**

Beine aus schwarz lackiertem Stahl. Sitz aus Sperrholz mit Polsterung aus Polyurethan. Rückenlehne aus Stahl mit Polsterung aus Polyurethan. Abnehmbarer Bezug aus Stoff oder Leder. Die Ausführung mit Sitzkissen aus Leder 95 und Rückenlehne mit Stoff Kat. 30 ist auch verfügbar.

**Butaquita  
con respaldo bajo**

Patas de acero pintado negro. Asiento en contrachapado y acolchado con poliuretano. Estructura del respaldo en acero acolchado de poliuretano. Tapizado desenfundable de tejido o de piel. Existe también una versión con asiento en piel 95 y respaldo en tejido cat. 30.

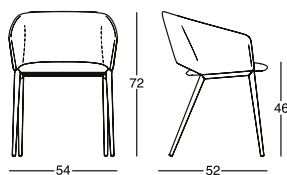



Tavoli, *consolle*,  
scrivanie

Tables, *console* tables,  
desks

Tables, consoles,  
tables bureau

Tische, Wandtische,  
*Schreibtische*

Mesas, *consolas*,  
mesas escritorios

# Ambrosiano <sup>2322</sup>



Design

Mist-o

2021

## Tavoli

Cavalletti in legno massello di rovere colore naturale o tinto nero a poro aperto. Piano in cristallo temperato colore fumé grigio in abbinamento al cavalletto tinto nero; oppure piano in particelle di legno placcato in rovere, disponibile nel colore naturale in abbinamento al cavalletto naturale oppure tinto poro aperto nel colore nero in abbinamento al cavalletto tinto nero; oppure piano in particelle di legno

placcato in laminato Fenix®, colore grigio chiaro o grigio antracite con bordo in rovere naturale in abbinamento al cavalletto colore naturale; oppure piano in marmo bianco di Carrara con verniciatura protettiva antimacchia, in poliestere trasparente opaco e in pietra Onsernone levigata al cavalletto naturale, con trattamento olio idrorepellente antimacchia, in abbinamento ai cavalletti nel colore naturale o tinto nero.

## Tables

Trestles in solid natural oak or painted black with open pore. Top available either in smoky grey tempered plate glass matching the black painted trestle; or in oak-plated particle wood, either natural matching the natural oak trestle or black painted with open pore matching the black painted trestle. Top is also available in Fenix® laminate plated particle wood in the shades light grey or anthracite grey with natural oak edge

matching the natural oak trestle; or in either white Carrara marble with stain-resistant protective varnish, in clear matt polyester or in naturally smoothed Onsernone stone, with water repellent stain-resistant oil treatment, matching the trestles in natural or black varnished oak.

## Tables

Tréteaux en rouvre naturel massif ou teinté noir à pore ouvert. Plateau en verre trempé gris fumé, en combinaison avec les tréteaux vernis noirs; ou plateau en particules de bois en couleur naturelle en combinaison avec les tréteaux naturel ou verni noir à pore ouvert en combinaison avec les tréteaux verni noir; ou plateau en particules de bois plaqué stratifié avec



74,5

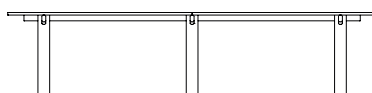

74,5



165x90 cm  
190x90 cm  
245x90 cm  
275x90 cm

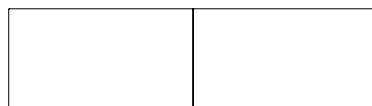

330x90 cm  
380x90 cm



laminé Fenix® gris clair ou couleur gris anthracite avec borde de rouvre naturel en combinaison avec les tréteaux de couleur naturelle; ou plateau en marbre blanc de Carrare avec peinture de protection anti taches en polyester transparent opaque, et pierre d' Onsernone, lissée naturellement, avec un traitement à l'huile hydrofuge et antitache, en combinaison avec les tréteaux de couleur naturelle ou teintés de couleur noir.

**Tische**  
Tragböcke aus naturfarbener oder schwarz lasierter Eiche. Platte aus grau rauchfarbenem Kristallglas, passend zum schwarz lasierten Tragbock; oder Platte aus Holz-Spannplatte mit naturfarbener Eiche furniert, passend zum naturfarbenen Tragbock oder schwarz lasierten Tragbock. Auch lieferbar ist die Platte aus Holz-Spannplatte furniert mit Fenix® Laminat, entweder

in den Farben hellgrau oder Anthrazit-grau, mit Rand aus naturfarbener Eiche passend zum naturfarbenen Tragbock; oder Platte entweder aus weißem Carrara-Marmor mit Fleckenschutz Lackierung aus klarem mattem Polyester oder aus Onsernone-Stein, naturgeschliffen mit wasserabweisendem, Fleckenschutz Öl behandelt, passend zu den Tragböcken aus naturfarbener oder schwarz lasierter Eiche.

**Mesas**  
Caballetes de roble macizo barnizado de color natural o teñido negro a poro abierto. Superficie de cristal templado, color gris humo, combinado con los caballetes teñidos negro; o superficie de aglomerado de madera aplacado en roble, disponible barnizado en color natural combinado con los caballetes barnizado color natural o teñidos a poro abierto en color negro combinado con los caballetes teñidos negro; o superficie de aglomerado

de madera aplacado con laminado Fenix®, de color gris claro o color gris antracita con borde de roble natural combinado con los caballetes barnizados de color natural; o superficie de mármol blanco de Carrara con laca de protección antimancha en poliéster opaco transparente, y piedra Onsernone pulida natural, con tratamiento de aceite repelente al agua anti-mancha, combinados con los caballetes barnizados en color natural o teñidos negro.

**Struttura/Frame/Structure/  
Gestell/Estructura**

Rovere naturale/  
Natural  
oakwood/  
Rouvre naturel/  
Naturfarbene  
Eiche/Roble  
natural

Rovere tinto  
nero/Black  
varnished oak/  
Rouvre teinté  
noir/Schwarz-  
gebeizte Eiche/  
Roble teñido  
negro



**Piano/Top/Plateau/Platte/Sobre**

Cristallo fumé  
grigio/Smoky  
grey plate glass/  
Verre gris fumé/  
Rauchfarbenes  
Kristallglas/  
Cristal gris humo

Rovere naturale/  
Natural  
oakwood/  
Rouvre naturel/  
Naturfarbene  
Eiche/Roble  
natural

Rovere tinto  
nero/Black  
varnished oak/  
Rouvre teinté  
noir/Schwarz  
gebeizte Eiche/  
Roble teñido  
negro

Laminato Fenix® /  
Fenix® laminate/  
Laminé Fenix® /  
Fenix® Laminat/  
Laminado Fenix®

Marmo di  
Carrara/Carrara  
marble/Marbre  
de Carrare/  
Carrara Marmor/  
Mármol de  
Carrara

Pietra  
Onsernone/  
Onsernone  
stone/Pierre  
Onsernone/  
Onsernone  
Stein/Piedra  
Onsernone





Design

Jacopo Zibardi

2010

**Tavoli**

Basamento e piano in Cristalplant®, materiale composito a base di resine poliestere e acriliche cariche di minerali, pigmentato in

massa colore bianco opaco. Nella versione 2577/C il piano è in cristallo temperato, extra-chiaro acidato verniciato bianco.

**Tables**

Base and top in Cristalplant®, composite material based on polyester and acrylic resins, loaded with minerals and mass pigmented in the

shade of matt white. For the model 2577/C the top is in tempered, extraclear, acidated plate glass, painted in the shade of white.

**Tables**

Base et plateau en Cristalplant®, matériau composite à base de résines polyester et acryliques, riches en minéraux, pigmenté

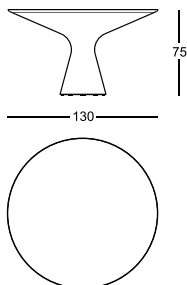

2577





dans la masse, couleur blanc mat. Pour la version 2577/C le plateau est en verre trempé, extra-clair acidifié verni blanc.

**Tische**  
Sockel und Tischplatte aus Cristalplant®, weißopakenpigmentiertem, mineralhaltigem Polyesterharz- und Acryl

Kompositmaterial. Bei der Version 2577/C ist die Tischplatte aus extra-klaarem, geätztem und gehärtetem Kristallglas, weißfarben.

**Mesas**  
Base y sobre de Cristalplant®, material compuesto a base de resinas poliéster y acrílicas cargadas de minerales,

pigmentado en masa color blanco opaco. Por el modelo 2577/C el sobre es de cristal templado, extra-claro al ácido barnizado blanco.

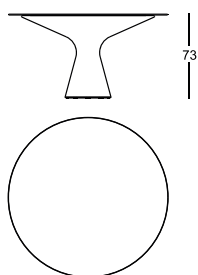

2577C

Ø 138 cm  
Ø 158 cm



Design

Zaven

2023

**Tavolo**

Basi in poliuretano rigido laccate opaco colore talco, caramello e alga o laccate lucide in colore talco, caramello metallizzato e alga metallizzato in abbinamento

a piani in MDF nei medesimi colori laccati opachi talco, caramello e alga.

**Table**

Hard polyurethane bases matt lacquered in the shades talc, caramel and algae or glossy lacquered in the shades talc, caramel metallic and algae metallic in

combination with MDF tops in the same matt lacquered colours talc, caramel and algae.

**Table**

Bases en polyuréthane rigide laqué mat dans les couleurs talc, caramel et algues ou laqué brillant dans les couleurs talc, caramel métallisé et algues métallisé

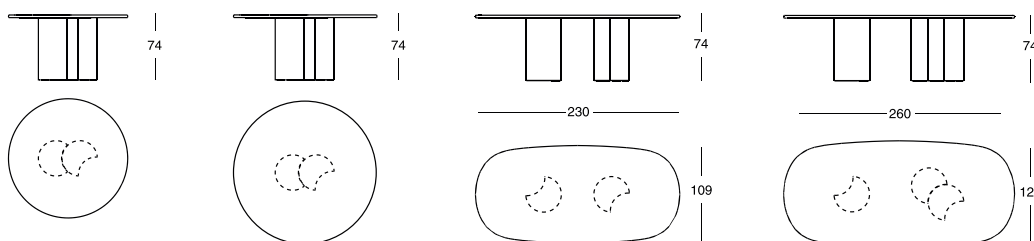

**Dimensioni/Sizes/  
Dimensions/  
Abmessungen/  
Medidas**

Ø 135 cm  
Ø 160 cm  
230x109 cm  
260x120 cm



en combinaison avec des plateaux en MDF dans les mêmes couleurs laquées mat talc, caramel et algues.

**Tisch**  
Untergestelle aus hartem Polyurethan, matt lackiert in den Farben Talkum, Karamell und Algen oder glänzend lackiert in den Farben Talkum, metallic-Karamell

und metallic-Algen in Kombination mit MDF-Platten in den gleichen matt lackierten Farben Talkum, Karamell und Algen.

**Mesa**  
Bases de poliuretano rígido lacado mate en colores talco, caramelo y alga o lacado brillante en colores talco, caramelo metalizado y alga metalizada en combinación

con sobres de MDF en los mismos colores lacado mate talco, caramelo y alga.

Talco opaco/Matt talc/Talc mat/Talkum matt/Talco mate

Talco lucido/Glossy lacquered talc/Talc laqué brillant/Talkum glänzend lackiert/Talco lacado brillante

Alga opaco/Matt algae/Algues mat/Algen matt/Alga mate

Alga metallizzato/Algae metallic/Algues métallisé/Metallic-Algen/Alga metalizada

Caramello opaco/Matt caramel/Caramel mat/Karamell matt/Caramelo mate

Caramello metallizzato/Caramel metallic/Caramel métallisé/Metallic-Karamell/Caramelo metalizado



# Calamo <sup>2730</sup>



Design

Gabriele Rosa

2013

## Scrivania

Struttura e piano in acciaio verniciato colore bianco, nero o grafite. Piano e vano portaoggetti in cuoio

pigmentato 90. Il vano è accessibile mediante apertura a ribalta.

## Desk

Varnished steel frame and top in black, white or graphite. Top and storage space in cowhide pigmentato

90. The storage space is accessed by a drop-leaf opening.

## Table bureau

Structure et plateau en acier verni couleur blanche, noire ou graphite. Plateau et élément porte-objets en

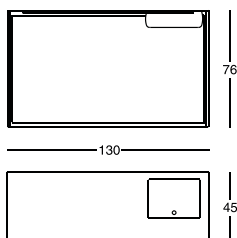



cuir sellier pigmentato 90.  
L'élément est accessible par  
une ouverture basculante.

**Schreibtisch**  
Gestell und Platte aus  
weiß- graphitfarben oder  
schwarz lackiertem Stahl.  
Platte und Ablagefach aus

Kernleder pigmentato 90.  
Das Ablagefach ist mit  
Kippöffnung versehen.

**Escritorio**  
Estructura y sobre de acero  
barnizado color blanco,  
negro o grafito. Sobre y  
compartimento portaobjetos

de cuero pigmentato  
90. Se puede acceder al  
compartimento mediante  
apertura abatible.

Struttura/Frame/Structure/Gestell/  
Estructura



# Cavour CM <sup>2690</sup>



Omaggio a

Carlo Mollino

1949

## Tavolo scrivania

Gambe in legno massello di rovere naturale o tinto nero, oppure in legno massello di noce Canaletto; verniciatura con finitura a cera. Cassettiera e piano estraibile impiallacciati in rovere naturale o tinto nero, oppure in noce Canaletto, verniciatura con finitura a cera, entrambi rivestiti con cristallo temperato, extra-chiaro, retro-verniciato nero. Piano in cristallo trasparente o extra-chiaro, oppure cristallo fumé grigio, in

abbinamento alla struttura in rovere tinto nero. A richiesta è disponibile un Executive kit che prevede il rivestimento in cuoio nero del fondo del piano estraibile e del primo cassetto della cassetiera, un sottomano in cuoio nero e un portapenne in legno massello realizzato nelle medesime finiture della scrivania.

## Writing desk

Legs in solid natural or black varnished oak, or in solid Canaletto walnut; wax-finished varnish. Extractable open tray and drawer element veneered in natural or black varnished oak, or in Canaletto walnut, wax-finished varnish, both covered with extra-clear tempered plate glass, back-painted in black. Clear or extra clear plate glass top, or smoky grey plate glass top, matching the black oak frame. Upon request an

Executive kit is available, including the bottom of the extractable open tray and the first drawer covered with black cowhide, one desk pad in black cowhide and one penholder in solid wood, made in the same finishes as the writing desk.

## Table bureau

Pieds en rovere naturel massif ou teinté noir ou en noyer Canaletto massif; verni finition cirée. Bloque tiroirs et plateau coulissant plaqués en rovere naturel ou teinté noir, ou en noyer Canaletto, verni finition cirée, les deux recouverts en verre trempé, extra clair, dos-vernì noir. Plateau en verre extra clair ou transparent, ou en verre gris fumé, en combinaison avec la structure en rovere teinté noir. Sur demande il est disponible un Executive

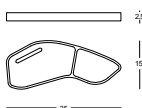
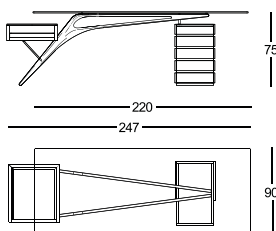

## Struttura/Frame/Structure/Gestell/Estructura

Rovere naturale/  
Natural  
oakwood/  
Rovere naturale/  
Naturfarbene  
Eiche/Roble  
natural

Rovere tinto nero/  
Black varnished  
oak/Rouvre teinté  
noir/Schwarz-  
gebeizte Eiche/  
Roble tenido  
negro

Noce Canaletto/  
Canaletto walnut/  
Noyer Canaletto/  
Nussbaum  
Canaletto/Nogal  
Canaletto





kit pour recouvrir en cuir sellier noir le fond du plateau coulissant et du premier tiroir du caisson, un sous-main en cuir sellier noir et pot à crayons en bois massif réalisé dans les mêmes finitions du bureau.

#### Schreibtisch

Beine aus massiver naturfarbener oder schwarz gebeizter Eiche, oder aus massivem Nussbaum Canaletto; Lackierung mit Wachs-Endbehandlung. Ausziehbares offenes Tablett und Schublade furniert mit naturfarbener oder schwarz gebeizter Eiche, oder mit Nussbaum Canaletto; Lackierung mit Wachs-Endbehandlung. Beide sind bezogen mit extra-klarem gehärtetem und nach hinten schwarz lackiertem Kristallglas.

Tischplatte aus transparentem oder extra-klarem Kristallglas, oder aus grau rauchfarbenem Kristallglas, passend zum Gestell aus schwarz gebeizter Eiche. Auf Nachfrage ist ein Executive Kit verfügbar, das den Bodenbezug des ausziehbaren offenen Tablettes und der ersten Schubladen aus schwarzem Kernleder, sowie eine Schreibunterlage aus schwarzem Kernleder, und einen Holzstifthalter in den gleichen Ausführungen des Schreibtisches enthält.

#### Mesa escritorio

Patas de madera maciza de roble natural o teñido negro o de nogal Canaletto macizo; pintura con acabado de cera. Cajonera y top extraíble contrachapados de roble natural o teñido negro, o de nogal Canaletto, pintura con acabado de cera, ambos tapizados de cristal templado extra claro, parte trasera pintada negra. Superficie de cristal transparente o extra claro, o de cristal gris humo, combinado con la estructura de roble teñido negro. Sobre pedido es disponible un

Executive kit para tapizar de cuero negro el fondo del top extraíble y del primero cajón de la cajonera, un deskpads de cuero negro y un portalápiz de madera maciza realizado en los mismos acabados del escritorio.

#### Piano/Top/Plateau/Platte/Sobre

Cristallo trasparente/Transparent plate glass/Verre transparent/Transparentes Kristallglas/Cristal transparente

Cristallo extra-chiaro/Extra-clear plate glass/Verre extra-clair/Extra-klares Kristallglas/Cristal extra-claro

Cristallo fumé grigio/Smoky grey plate glass/Verre gris fumé/Rauchfarbenes Kristallglas/Cristal gris humo



# Comacina <sup>2725</sup>



Design

Piero Bottoni

1930

## Scrivania

Struttura in tubo di acciaio inox. Piano e cassetteria verniciati goffrati antigraffio nei colori bianco o nero. Il

piano può essere con inserto in cuoio pigmentato.

## Writing desk

Stainless steel tubular frame. Top and drawer unit finished with scratch resistant embossing in the colours

black or white. The top can be with cowhide pigmentato insert.

## Table bureau

Structure en tube d'acier inox. Plateau et caisson vernis anti-rayures dans les couleurs blanche ou noire. Le

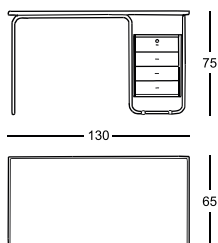





plateau peut être avec finition en cuir sellier pigmentato.

**Schreibtisch**  
Gestell aus Inox-Stahl-Rohr. Platte und Schubladen mit kratzfester Lackierung in den Farben weiß oder

schwarz. Die Platte ist auch mit eingelegtem Kernleder pigmentato.

**Mesa escritorio**  
Estructura en tubo de acero inox. Sobre y cajonera lacados con relieve antirasguño en los

colores blanco o negro. El sobre puede ser también con inserción de cuero pigmentato.



Design

Prospero Rasulo

2009

#### Tavolo

Basamento in Cristalplant®, materiale composito a base di resine poliestere e acriliche cariche di minerali pigmentato in massa colore bianco opaco. Piano in cristallo temperato, extrachiaro acidato verniciato bianco, oppure in marmo bianco di Carrara. È prevista anche la versione con base verniciata opaca nera in abbinamento al piano in marmo Sahara Noir, con verniciatura protettiva antimacchia in poliestere trasparente opaco.

#### Table

Base in Cristalplant®, composite material based on polyester and acrylic resins, loaded with minerals and mass pigmented in the shade of matt white. Tempered, extraclear, acidated plate glass top painted in the shade of white or made of white Carrara marble. The version with matt black varnished base matching the Sahara Noir marble top, with stain-resistant clear matt polyester protective varnish, is also available.

#### Table

Base en Cristalplant®, matériau composite à base de résines polyester et acryliques, riches en minéraux, pigmenté dans la masse, couleur blanc mat. Plateau en verre trempé, extrclair acidifié verni blanc, ou bien en marbre blanc de Carrare. La version avec base vernie noire mat en combinaison avec plateau en marbre Sahara Noir avec vernis de protection anti-taches en polyester transparent mat est aussi disponible.

#### Tisch

Sockel aus Cristalplant®, weißpak maßenpigmentiertem, mineralhaltigem Polyesterharz und Acryl Kompositmaterial. Tischplatte aus weißem extraklarem, geätztem und gehärtetem Kristallglas oder aus weißem Carrara-Marmor. Die Ausführung mit schwarz mattem lackiertem Sockel nur passend zur Platte aus Sahara Noir Marmor, mit Fleckenschutz Lackierung aus klarem mattem Polyester, ist auch lieferbar.

#### Mesa

Base de Cristalplant®, material compuesto a base de resinas de poliéster y acrílicas cargadas de minerales pigmentado en masa color blanco opaco. Superficie de cristal templado, extraclaro al ácido, barnizado blanco o en mármol blanco de Carrara. Existe también la versión con base barnizada mate color negro en combinación solo con la superficie de mármol Sahara Noir con laca de protección antimancha, en poliéster opaco transparente.

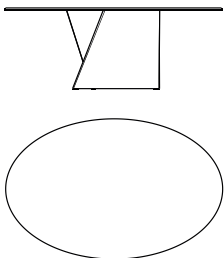

Dimensioni/Sizes/Dimensions/  
Abmessungen/Medidas

Ø 138 cm  
Ø 158 cm  
128x198 cm  
138x238 cm \*

\*Solo per piano in marmo/For marble top only/Seulement pour plateau en marbre/Nur für Marmor-Platte/Solo por sobre en mármol

#### Piano/Top/Plateau/Platte/Sobre

Cristallo extra-chiaro acidato bianco/  
Extraclear, acidated white plate glass/  
Verre extrclair acidifié blanc/ Weiße  
extraklares geätztes Kristallglas/Cristal  
extraclaro al ácido blanco



Marmo di  
Carrara/Carrara  
marble/Marbre  
de Carrare/  
Carrara Marmor/  
Mármol de  
Carrara



Marmo Sahara  
Noir/Sahara  
Noir marble/  
Marbre Sahara  
Noir/Sahara Noir  
Marmor/Mármol  
Sahara Noir



#### Basamento/ Base/Piètement/ Sockel/Base





Design

Prospero Rasulo

2010

### Tavolo

Basamento in Cristalplant<sup>®</sup>, materiale composito a base di resine poliester e acriliche cariche di minerali pigmentato in massa colore bianco opaco o laccato nero. Piano in cristallo trasparente oppure fumé grigio in abbinamento solo con base nera.

### Table

Base in Cristalplant<sup>®</sup>, composite material based on polyester and acrylic resins, loaded with minerals and mass pigmented in the shade of matt white, or black glossy lacquered. Plate glass top, clear or smoky grey, only matching the black base.

### Table

Base en Cristalplant<sup>®</sup>, matériau composite à base de résines polyester et acryliques, riches en minéraux, pigmenté dans la masse, couleur blanc mat, ou laqué brillant noir. Plateau en verre transparent ou fumé gris en combinaison seulement avec la base noire.

### Tisch

Sockel aus Cristalplant<sup>®</sup>, weißopak maßenpigmentiertem, mineralhaltigem Polyesterharz und Acryl Kompositmaterial, oder schwarz glanzlackiert. Tischplatte aus Kristallglas, klar oder grau rauchfarben nur passend zu dem schwarzem Sockel.

### Mesa

Base de Cristalplant<sup>®</sup>, material compuesto a base de resinas de poliéster y acrilicas cargadas de minerales pigmentado en masa color blanco opaco, o lacada brillante negra. Superficie de cristal transparente o gris humo en combinación solo con la base negra.

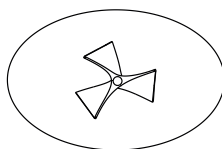
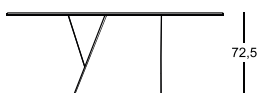

### Dimensioni/Sizes/Dimensions/ Abmessungen/Medidas

Ø 138 cm  
Ø 158 cm  
128x198 cm  
138x238 cm

### Piano/Top/Plateau/Platte/Sobre

Cristallo trasparente/Transparent plate glass/Verre transparent/Transparentes Kristallglas/Cristal transparente



Cristallo fumé grigio/Smoky grey plate glass/Verre gris fumé/Rauchfarbenes Kristallglas/Cristal gris humo



### Basamento/ Base/Piètement/ Sockel/Base





Design

Piero Bottoni

1936

**Tavolo**

Esemplare numerato.  
Struttura in Polimex®, rivestita in cemento con finitura acrilica e trattamento di protezione nano tecnologico antimacchia a base di biossido di titanio, colore grigio.

**Table**

Numbered piece. Frame in Polimex®, covered with acryl finish cement with protective titanium dioxide nanotech stain-resistant treatment, in the shade of grey.

**Table**

Exemplaire énuméré.  
Structure en Polimex®, revêtu en ciment avec finition acrylique et traitement de protection nano technologique anti-tâche à base de bioxyde de titane, couleur gris.

**Tisch**

Nummeriertes Exemplar.  
Gestell aus Polimex®, mit Zement verkleidet, mit Akrylfinish und nanotechnologischer Fleckenschutzbehandlung mit Titandioxid, in der Farbe grau.

**Mesa**

Pieza numerada. Estructura de Polimex®, revestido en cemento con acabado acrilico y tratamiento de protección nanotecnológico antimancha a base de dióxido de titanio, color gris.

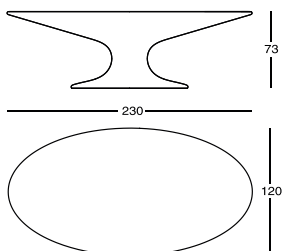

# Leonardo <sup>2650</sup>



Design

Achille Castiglioni

1969

## Tavolo da lavoro

Struttura in faggio evaporato, colore naturale. Piano placcato in laminato colore bianco, oppure in cristallo temperato. Regolabile in altezza.

## Working table

Natural varnished steam-treated beech trestle. Top coated with white plastic laminate, or with tempered plate glass. Adjustable height.

## Table de travail

Structure en hêtre évaporé, couleur naturelle. Plateau plaqué en laminé plastique, couleur blanche, ou en verre trempé. Hauteur réglable.

## Arbeitstisch

Tragböcke aus gedampfter Buche, naturfarben. Platte mit weißem Schichtpreßstoff Laminat beschichtet, oder aus hitzebeständigem Kristallglas. Höhenverstellbar.

## Mesa de trabajo

Estructura de haya vaporizada, color natural. Sobre aplacado con laminado, color blanco o de cristal templado. Altura regulable.

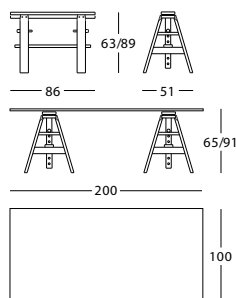

## Piano/Top/Plateau/Platte/Sobre

Cristallo/Glass/  
Verre/Kristallglas/  
Cristal

Laminato/  
Laminate/Laminé/  
Laminat/Laminado



# Marcuso <sup>2530</sup>



Design

Marco Zanuso

1969

## Tavolo

Piano in cristallo, trasparente oppure rivestito in cemento, colore antracite, con finitura acrilica e trattamento di protezione nanotecnologico antimacchia. Gambe in acciaio inox, abbinare al piano in cristallo trasparente o verniciate colore antracite abbinare al piano rivestito in cemento.

## Table

Plate glass top, either clear or covered in acrylic finish cement- in the shade anthracite- with protective nanotech stain-resistant treatment. Stainless steel legs, matching the clear top, or in anthracite painted steel, matching the cement covered top.

## Table

Plateau en verre, transparent ou en ciment couleur anthracite avec une finition acrylique et un traitement nanotechnologique antitaches. Pieds en acier, finition inox pour le plateau en verre ou en couleur anthracite pour le plateau en ciment.

## Tisch

Platte aus Kristallglas, klar oder mit anthrazitfarbenem Zement verkleidet, mit Akryl Finish und nanotechnologischer Fleckenschutzbehandlung. Beine aus Inox Stahl, passend zu klarer Kristallglas-Platte, oder anthrazitfarben lackiert, passend zur Zement-Platte.

## Mesa

Sobre de cristal, transparente o cemento de color antracita, con acabado acrílico y un tratamiento nanotecnológico anti manchas. Patas de acero inox, con el sobre en cristal transparente, o color antracita con el sobre en acabado cemento.

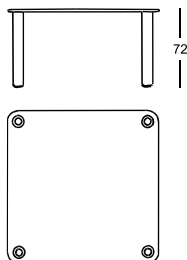

Dimensioni/Sizes/Dimensions/  
Abmessungen/Medidas

100x100 cm  
140x140 cm  
90x200 cm

## Piano/Top/Plateau/Platte/Sobre

Cristallo trasparente/ Transparent plate glass/Verre transparent/ Transparentes Kristallglas/Cristal transparente	Cemento/ Cement/ Cement/ Zement/ Cemento
--	--



Struttura/Frame/Structure/Gestell/  
Estructura

# Orione <sup>2337</sup>



Design

Roberto Barbieri

1996

## Tavolo

Piano in cristallo. Struttura in rovere naturale con tiranti in acciaio nichelato e spazzolato, oppure in rovere tinto nero, con tiranti in acciaio nichelsatinato nero.

## Table

Plate glass top. Frame in natural oak with brushed and nickel-plated steel tie-rods, or in black varnished oak, with black nickel satin finished steel tie-rods.

## Table

Plateau en verre. Structure en rovere naturel, avec tirants en acier niquelé et brossé, ou en rovere teinté noir, avec tirants en acier nickel-satiné noir.

## Tisch

Platte aus Kristallglas. Gestell aus naturfarbener Eiche, mit Streben aus vernickeltem und gebürstetem Stahl, oder aus schwarz gebeizter Eiche mit Streben aus schwarz-vernickeltem und mattedem Stahl.

## Mesa

Superficie de cristal. Estructura de roble natural, con tirantes de acero niquelado y cepillado, o de roble teñido negro, con tirantes de acero niquelado mate negro.

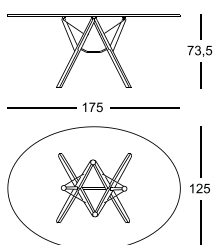

## Dimensioni/Sizes/Dimensions/Abmessungen/Medidas

Ø 125 cm  
Ø 135 cm  
125x175 cm

## Struttura/Frame/Structure/Gestell/Estructura

Rovere naturale/Natural oakwood/  
Rouvre naturel/Naturfarbene Eiche/  
Roble natural

Rovere tinto nero/Black varnished oak/  
Rouvre teinté noir/Schwarz-gebeizte  
Eiche/Roble teñido negro





Design

Joe Colombo

1968

#### Tavolo da gioco

Piani in laminato plastico stratificato, colore bianco. Panno verde con bordo in pelle, amovibile. Gambe in acciaio inox.

#### Card table

Tops in white layered plastic laminate. Removable, leather trimmed green baize. Stainless steel legs.

#### Table de jeu

Plateaux en laminé plastique stratifié, couleur blanche. Tapis vert avec bords en cuir, amovible. Pieds en acier inox.

#### Spieltisch

Tischplatten aus massivem Schichtpreßstoff Laminat, weißfarben. Grünes Filztuch mit Lederrand, abnehmbar. Beine aus Inox-Stahl.

#### Mesa de juego

Sobres de laminado plástico estratificado, color blanco. Tapete verde extraíble con borde de piel. Patas de acero inox.

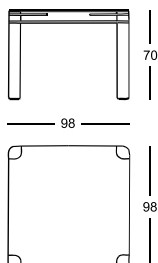



# Quaderna Table <sup>2600</sup>

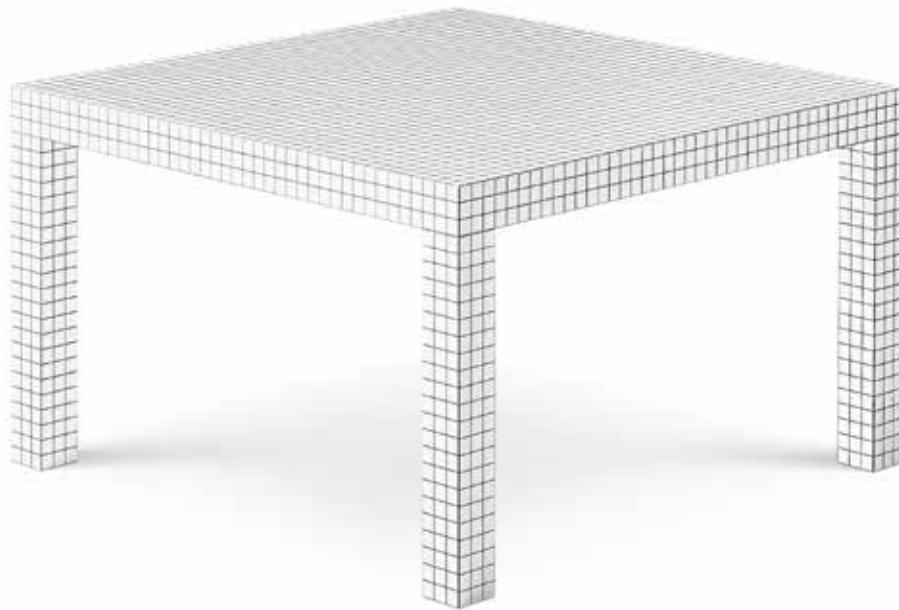

Design

Superstudio

1969-1972

**Tavolo/tavolo scrivania**  
Struttura in legno tamburato  
placcato in laminato Print,  
colore bianco, a stampa  
digitale a quadretti neri con  
interasse di 3 cm.

**Table/writing desk**  
Honeycomb core structure  
coated with white plastic  
laminate, digitally printed  
with black squares at 3 cm  
spacing.

**Table/table bureau**  
Structure en panneau  
alvéolaire plaqué en Print,  
couleur blanche, imprimé en  
digital à carrés noirs avec  
entraxe de 3 cm.

**Tisch/Schreibtisch**  
Gestell aus Sperrholz  
mit weißem Print belegt.  
Digitaldruck mit kariertem  
Muster, Linienabstand 3 cm.

**Mesa/mesa escritorio**  
Estructura de madera  
enchapada aplacada con  
laminado Print, color blanco,  
a impresión digital en  
cuadritos negros de 3 cm.

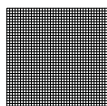
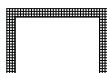

Dimensioni/Sizes/Dimensions/  
Abmessungen/Medidas

111x111 cm  
126x126 cm  
90x180 cm

# Quaderna Desk <sup>2830</sup>

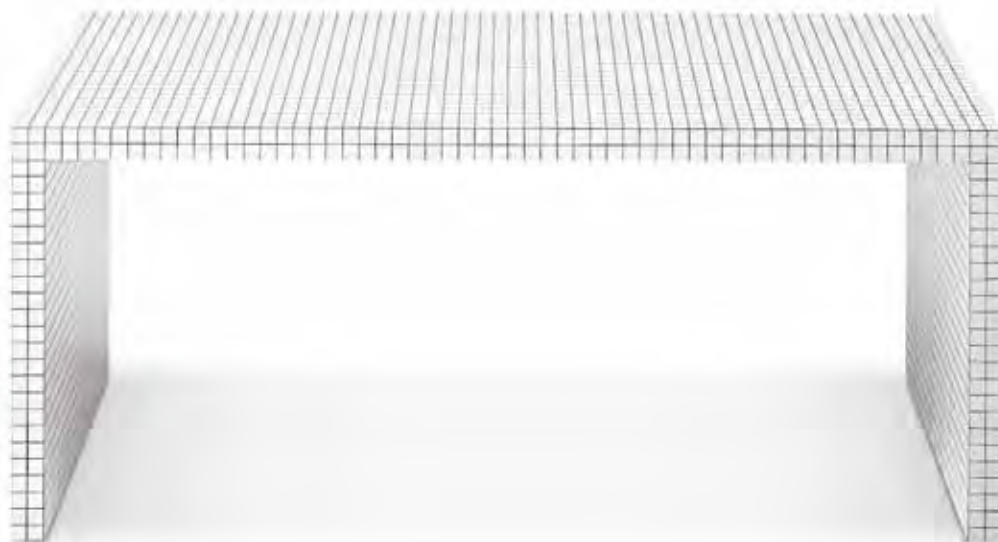

Design

Superstudio

1969-1972

**Tavolo/tavolo scrivania**

Struttura in legno tamburato placcato in laminato Print, colore bianco, a stampa digitale a quadretti neri con interasse di 3 cm.

**Table/writing desk**

Honeycomb core structure coated with white plastic laminate, digitally printed with black squares at 3 cm spacing.

**Table/table bureau**

Structure en panneau alvéolaire plaqué en Print, couleur blanche, imprimé en digital à carrés noirs avec entraxe de 3 cm.

**Tisch/Schreibtisch**

Gestell aus Sperrholz mit weißem Print belegt. Digitaldruck mit kariertem Muster, Linienabstand 3 cm.

**Mesa/mesa escritorio**

Estructura de madera enchapada aplacada con laminado Print, color blanco, a impresión digital en cuadritos negros de 3 cm.

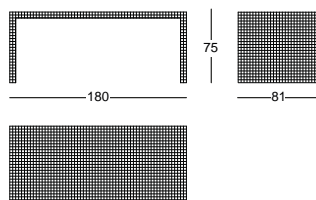

# Quaderna Writing Desk <sup>2750</sup>

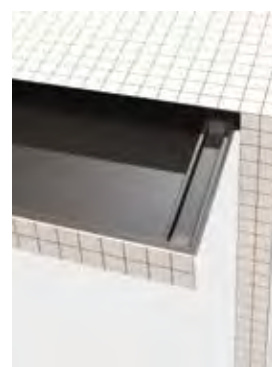

Design

Superstudio

1969-1972

## Scrittoio

Struttura in legno tamburato placcato laminato Print, colore bianco, a stampa digitale a quadretti con interasse di 3 cm. Cassetto estraibile a scomparsa ricavato nello spessore del piano, vano cassetto in legno verniciato goffrato antigraffio colore nero.

## Desk

Honeycomb core structure coated with white Print laminate, digitally printed with black squares at 3 cm spacing. The top hides a retractable pull-out drawer, with a drawer compartment in black scratch-resistant embossed painted wood.

## Bureau

Structure en panneau alvéolaire plaqué en laminé Print, couleur blanche, imprimé en digital à carrés noirs avec entraxe de 3 cm. Tiroir rétractable obtenu dans l'épaisseur du dessus du plateau; compartiment intérieur du tiroir en bois verni gaufré noir résistant aux rayures.

## Schreibtisch

Gestell aus Sperrholz mit weißem Print Laminat belegt. Digitaldruck mit kariertem Muster, Linienabstand 3 cm. Eine einziehbare Schublade befindet sich in dem Dicken der Oberplatte mit Schubladenfach aus schwarz kratzfestem und lackiertem Holz.

## Escritorio

Estructura de madera aplacada con laminado Print, color blanco, a impresión digital en cuadritos negros de 3 cm. Cajón retráctil obtenido en el grosor de la parte superior; compartimento del cajón en madera pintada en relieve antirasguño, color negro.

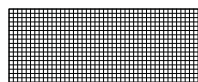
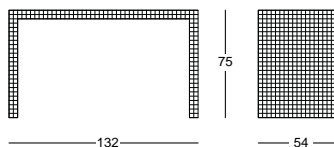

# Quaderna Console <sup>710</sup>



Design

Superstudio

1969-1972

## Consolle

Struttura in legno tamburato placcato in laminato Print, colore bianco, a stampa digitale a quadretti neri con interasse di 3 cm.

## Console table

Honeycomb core structure coated with white plastic laminate, digitally printed with black squares at 3 cm spacing.

## Console

Structure en panneau alvéolaire plaqué en Print, couleur blanche, imprimé en digital à carrés noirs avec entraxe de 3 cm.

## Wandtisch

Gestell aus Sperrholz mit weißem Print belegt. Digitaldruck mit kariertem Muster, Linienabstand 3 cm.

## Consola

Estructura de madera aplacada con laminado Print, color blanco, a impresión digital en cuadrillos negros de 3 cm.

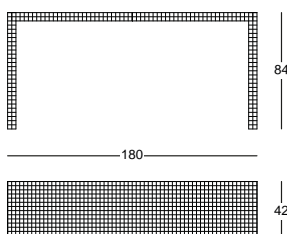

# Reale <sup>2320</sup>



Omaggio a

Carlo Mollino

1948

## Tavolo

Piano in cristallo trasparente con o senza bordi bisellati, oppure in marmo Emperador, con verniciatura protettiva antimacchia in poliestere trasparente opaco. Struttura in legno massello di rovere naturale o tinto noce Canaletto, oppure tinto nero; verniciatura con finitura a cera.

## Table

Clear plate glass top, with or without bevelled edges or in Emperador marble, with stain-resistant protective varnish, in clear matt polyester. Frame in solid natural or black varnished oak, or in Canaletto walnut-dyed oak; wax-finished varnish.

## Table

Plateau en verre transparent avec ou sans bords biseautés, ou en marbre Emperador, avec vernis de protection anti-taches en polyester transparent mat. Structure en rouvre naturel massif ou teinté noir, ou en rouvre teinté noyer Canaletto; verni finition cirée.

## Tisch

Tischplatte aus transparentem Kristallglas mit oder ohne schräg-abgeschliffenen Rändern, oder aus Emperador Marmor, mit Fleckenschutz-Lackierung aus klarem mattem Polyester. Gestell aus massiver naturfarbener oder schwarz gebeizter Eiche oder aus Nussbaum Canaletto gebeizter Eiche; Lackierung mit Wachs-Endbehandlung.

## Mesa

Superficie de cristal transparente con o sin borde biselado, o en mármol Emperador, con laca de protección anti mancha en poliéster transparente mate. Estructura de madera maciza de roble natural o teñido negro o de roble teñido nogal Canaletto; pintura con acabado de cera.

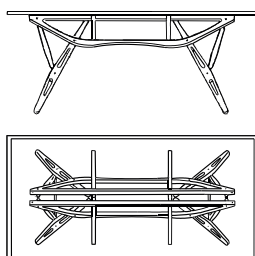

**Dimensioni/Sizes/  
Dimensions/  
Abmessungen/  
Medidas**

80x160 cm  
90x180 cm  
90x200 cm

## Struttura/Frame/Structure/Gestell/ Estructura

Rovere naturale/  
Natural oakwood/  
Rouvre naturel/  
Naturfarbene  
Eiche/Roble  
natural

Rovere tinto nero/  
Black varnished  
oak/Rouvre teinté  
noir/Schwarz-  
gebeizte Eiche/  
Roble teñido  
negro

Rovere tinto noce  
Canaletto/Cana-  
letto walnut dyed  
oak/Rouvre teinté  
noyer Canaletto/  
Nussbaum  
Canaletto  
gebeizte Eiche/  
Roble teñido nogal  
Canaletto



## Piano/Top/Plateau/Platte/Sobre

Cristallo  
trasparente/  
Transparent  
plate glass/Verre  
transparent/  
Transparentes  
Kristallglas/Cristal  
transparente

Marmo  
Emperador/  
Emperador  
marble/Marbre  
Emperador/  
Emperador/  
Marmor/Marmól  
Emperador



# Reale CM <sup>2320</sup>



Omaggio a

Carlo Mollino

1948

## Tavolo

Struttura in legno massello di rovere naturale o tinto nero oppure in legno massello di noce Canaletto colore naturale; verniciatura con finitura a cera. Piano in cristallo extra-chiaro con bordo a taglio inclinato, oppure in cristallo fumé grigio con bordo a taglio inclinato, in abbinamento alla struttura in rovere tinto nero.

## Table

Frame in solid natural or black varnished oak, or in solid natural Canaletto walnut; wax-finished varnish. Extra clear plate glass top, with inclined cut edges, or smoky grey plate glass top, with inclined cut edges, matching the black oak frame.

## Table

Structure en rouvre naturel massif ou teinté noir ou en noyer Canaletto massif, couleur naturelle; verni finition cirée. Plateau en verre extra- clair à bord coupé oblique, ou en verre gris fumé à bord coupé oblique, en combinaison avec la structure en rouvre teinté noir.

## Tisch

Gestell aus massivem naturfarbener oder schwarz gebeizter Eiche, oder aus massivem naturfarbenem Nussbaum Canaletto. Lackierung mit Wachs-Endbehandlung. Tischplatte aus extra-klarem Kristallglas, mit geneigten geschnittenen Rändern, oder aus grau rauchfarbenem Kristallglas mit geneigten geschnittenen Rändern, passend zu dem Gestell aus schwarz gebeizter Eiche.

## Mesa

Estructura de madera maciza de roble natural o teñido negro o de madera maciza de nogal Canaletto color natural; pintura con acabado de cera. Superficie de cristal extra claro con borde de corte inclinado, o de cristal gris humo con borde de corte inclinado, combinado con la estructura en roble teñido negro.

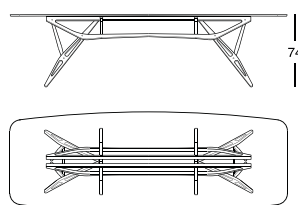

**Dimensioni/Sizes/  
Dimensions/  
Abmessungen/  
Medidas**

90x220 cm  
100x250 cm  
100x280 cm

## Struttura/Frame/Structure/Gestell/Estructura

Rovere naturale/  
Natural oakwood/  
Rouvre naturel/  
Naturfarbene  
Eiche/Roble  
natural

Rovere tinto nero/  
Black varnished  
oak/Rouvre teinté  
noir/Schwarz-  
gebeizte Eiche/  
Roble teñido  
negro

Noce Canaletto/  
Canaletto walnut/  
Noyer Canaletto/  
Nussbaum  
Canaletto/Nogal  
Canaletto



## Piano/Top/Plateau/Platte/Sobre

Cristallo extra-  
chiaro/Extra-clear  
plate glass/Verre  
extra-clair/Extra-  
klares Kristallglas/  
Cristal extra-claro

Cristallo fumé  
grigio/Smoky  
grey plate glass/  
Verre gris fumé/  
Rauchfarbenes  
Kristallglas/Cristal  
gris humo



# Tucano <sup>2740</sup>



Design

Monica Förster

2020

**Scrigno**

Struttura in acciaio verniciato colore nero opaco. Piano rivestito in cuoio pigmentato 90.

**Writing desk**

Matt black varnished steel frame. Top covered with cowhide pigmentato 90.

**Table bureau**

Structure en acier verni noir mat. Plateau en cuir sellier pigmentato 90.

**Schreibtisch**

Gestell aus matten schwarz lackiertem Stahl. Platte mit Kernleder pigmentato 90 bezogen.

**Escritorio**

Estructura de acero pintado color negro mate. Superficie tapizada de cuero pigmentado 90.

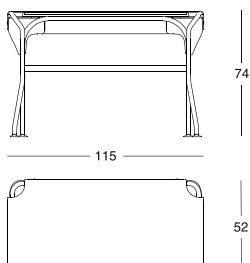



Design

Garcia Cumini

2017

## Tavolo

Piano in legno placcato in rovere, verniciato colore naturale, con sottopiano verniciato colore grigio, o a poro aperto colore nero, con sottopiano verniciato colore nero, oppure in noce Canaletto, verniciato colore naturale, con sottopiano verniciato colore nero. Gambe in abbinamento rispettivamente in legno massello di rovere verniciato colore naturale, o di rovere verniciato a poro aperto nero, oppure di noce Canaletto, verniciato colore naturale. Piedino regolabile in alluminio verniciato nero.

## Table

Top available either in natural painted oak veneered wood, with grey painted under-top, or black painted with an open pore, with black painted under-top or in natural painted Canaletto walnut veneered wood, with black painted under-top. Legs are available respectively in natural painted solid oak, or in open pore black painted oak, or in natural painted Canaletto walnut. Black painted aluminium adjustable foot.

## Table

Plateau en bois plaqué dans la finition rouvre, verni couleur naturel, avec un sous-plateau verni gris, ou verni à pore ouvert noir avec sous-plateau verni noir, ou plaqué en noyer Canaletto, verni couleur naturel avec un sous-plateau verni noir. Pieds en combinaison respectivement en bois massif de rouvre, verni couleur naturel, ou en rouvre verni à pore ouvert noir, ou en noyer Canaletto, verni couleur naturel. Petit pied réglable en aluminium verni noir.

## Tisch

Holzplatte furniert mit naturfarben lackierter Eiche, mit grau lackierter Unterplatte, oder schwarz lasiert mit schwarz lackierter Unterplatte, oder mit naturfarben lackiertem Nussbaum Canaletto, mit schwarz lackierter Unterplatte. Beine aus massiver Eiche, naturfarben lackiert, oder bzw. aus schwarz lasierter Eiche oder bzw. aus Nussbaum Canaletto, naturfarben lackiert. Verstellbarer Fuß aus schwarz lackiertem Aluminium.

## Mesa

Superficie de madera chapada en roble barnizado natural, con la parte inferior pintada de color gris, o pintada a poro abierto, color negro, con la parte inferior pintada de color negro, o en nogal Canaletto barnizado natural, con la parte inferior pintada de color negro. Patas combinadas respectivamente en madera maciza de roble, barnizado natural, o de roble pintado a poro abierto negro, o de nogal Canaletto barnizado natural. Pie regulable en aluminio pintado negro.

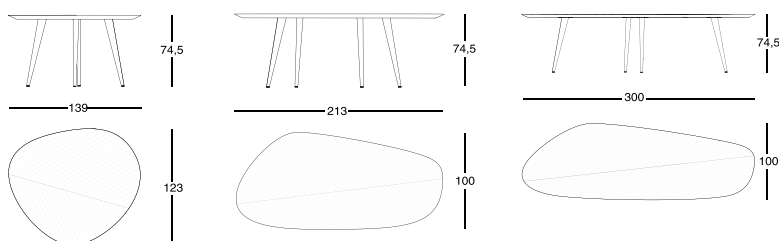

## Piani/Tops/Plateaux/Platten/Sobres

Rovere naturale/Natural oakwood/Rouvre naturel/Naturfarbene Eiche/Roble natural

Rovere tinto nero/Black varnished oak/Rouvre teinté noir/Schwarzgebeizte Eiche/Roble teñido negro

Noce Canaletto/Canaletto walnut/Noyer Canaletto/Nussbaum Canaletto/Nogal Canaletto





# Tweed Marble 2318

NEW

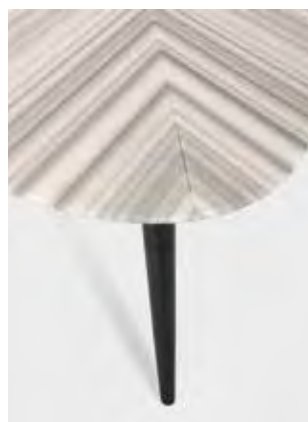

Design

Garcia Cumini

2023

## Tavolo

Piano in marmo Striato Olimpico con verniciatura protettiva antimacchia in poliestere trasparente opaca. Sotto piano in MDF laccato colore nero opaco. Gambe in tubolare di acciaio verniciato colore nero opaco.

## Table

Top in Striato Olimpico marble with stain resistant protective varnish in clear matt polyester. MDF under-top, lacquered matt black. Legs in matt black painted tubular steel.

## Table

Plateau en marbre Striato Olimpico, vernis de protection anti-taches en polyester transparent mat. Sous-plateau en MDF, laqué noir mat. Pieds en tube d'acier verni noir mat.

## Tisch

Platte aus Striato Olimpico-Marmor, mit Fleckenschutz Lackierung aus transparentem matten Polyester. Unterplatte aus matt schwarz lackiertem MDF. Beine aus matt schwarz lackiertem Stahlrohr.

## Mesa

Sobre de mármol Striato Olimpico, con laca de protección antimancha, en poliéster opaco transparente. Parte inferior de MDF lacado en negro mate. Patas de tubo de acero pintadas en negro mate.

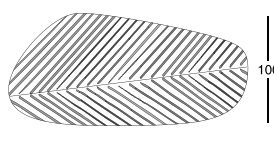
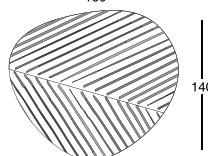
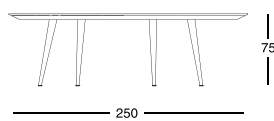
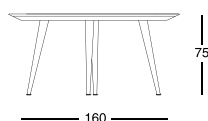

160

250



*Letti*  
*Beds*  
*Lits*  
*Betten*  
*Camas*

162–177



Design

Emaf Progetti

2005

### Letti con o senza vano contenitore

Struttura in acciaio. Molleggio in doghe di faggio curvato con regolatori di rigidità. Testiera e base imbottite in poliuretano/fibra poliestere termolegata. Rivestimento trapuntato, sfilabile, in stoffa o in pelle. Il letto, nella versione 1874, all'interno della base, è dotato di un vano contenitore

al quale si accede alzando il materasso tramite un meccanismo. A richiesta, solo per il modello 1875, è possibile fornire il letto con supporti angolari regolabili che permettono l'inserimento della rete ad altezze diverse e la misura per il materasso da 210 cm di lunghezza.

### Beds with or without container unit

Steel frame. Suspension in bent beech strips with stiffness adjusters. Upholstered base and headboard in polyurethane/heat-bound polyester fibre. Removable quilted cover in fabric or leather. The model 1874, fitted inside the base, is furnished with a container unit accessed by lifting the

mattress with a special device. Upon request, only for the model 1875, the bed with adjustable corner supports that enable to place the springing at different heights and the bed size for 210 cm. long mattress can be supplied.

### Lits avec ou sans élément de rangement

Structure en acier. Suspension en douves de hêtre courbé, avec régulateurs de rigidité. Cadre et tête de lit rembourrés en polyuréthane/fibre polyester liée à chaud. Revêtement surpiqué déhoussable en tissu ou en cuir. En version 1874 le lit, à l'intérieur du cadre, est doté d'un élément

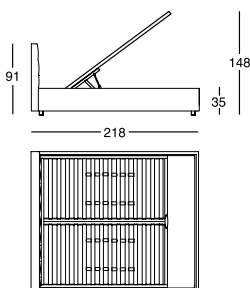

1874

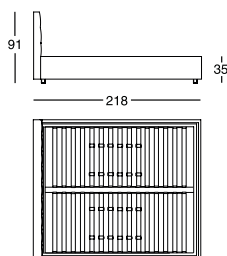

1875

### Dimensioni/Sizes/Dimensions/Abmessungen/Medidas

15x218 cm	(140x200 cm)*
17x218 cm	(160x200 cm)*
19x218 cm	(180x200 cm)*
21x218 cm	(200x200 cm)*

\* Dimensioni del materasso/Mattress sizes/Dimensions du matelas/Abmessungen der Matratze/Medidas del colchón



de rangement auquel l'on accède en levant le matelas à l'aide d'un mécanisme. Sur demande, seulement pour le modèle 1875, il est possible de fournir le lit avec des supports angulaires réglables qui permettent l'introduction du sommier à des hauteurs différentes et dans la mesure pour un matelas de 210 cm de longueur.

**Betten mit oder ohne Stauraum**

Gestell aus Stahl. Lattenrost aus gebogenen Buchen- Dauben, in der Nachgiebigkeit regulierbar. Unterteil und Kopfteil mit Polsterung aus Polyurethan/ wärmegebundener Polyesterfaser. Abnehmbarer Bezug aus Stepp-Stoff oder Leder. Die Ausführung 1874 hat im Bettrahmen einen integrierten Stauraum, der über einen Mechanismus zum Anheben

der Matratze zugänglich wird. Auf Nachfrage, nur für die Version 1875, ist das Bett mit verstellbaren Winkelhalterungen lieferbar, die die Einfügung des Rostes in verschiedenen Höhen ermöglichen. Die Bett-Maße für die Matratze 210 cm lang ist auch verfügbar.

**Camas con o sin base contenedora**

Estructura de acero. Somier con lamas de haya curvadas con reguladores de rigidez. Base y cabezal acolchados de poliuretano/fibra poliéster termounida. Tapizado pespunteado desenfundable de tejido o de piel. El modelo 1874 está provisto de una base contenedora a la cual se accede alzando el colchón por medio de un mecanismo al efecto. Sobre pedido, solo por el modelo 1875

podemos suministrar la cama con los soportes angulares regulables para poder poner el somier a alturas diferentes y en la medida para el colchón de 210 cm de largo.



Design

Gabriele Rosa

2018

#### Letti con rete unica o separata

Piedini e mensole in acciaio rivestiti in cuoio pigmentato 90 nel medesimo colore. Struttura in acciaio con doghe in faggio curvato, verniciato naturale. Imbottitura testiera e base in poliuretano/fibra poliestere termolegata. Rivestimento, sfilabile, in stoffa o pelle. A richiesta sono disponibili le

misure per i materassi da 210 e 220 cm di lunghezza ed è possibile rivestire interamente il retro della testiera nel medesimo tessuto o pelle del letto.

#### Beds with single or separate springing

Steel feet and shelves covered with cowhide pigmentato 90 in the same colour. Steel frame with suspension on natural bent beech strips. Base and headboard upholstered in polyurethane/heat bound polyester fibre. Removable fabric or leather cover. Upon request the bed sizes for

210 cm. and 220 cm. long mattresses are available, as well as the headboard can be fully covered with the same fabric or leather of the bed.

#### Lits avec sommier single ou séparé

Pieds et étagère en acier recouverts en cuir sellier pigmentato 90 dans la même couleur. Structure en acier avec douves en hêtre courbé, verni naturel. Cadre et tête de lit rembourrés en polyuréthane/fibre polyester liée à chaud. Revêtement déhoussable en tissu ou en cuir. Sur demande, il sont

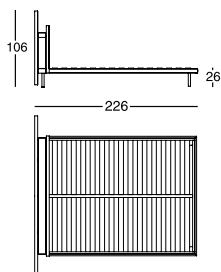

#### Dimensioni/Sizes/Dimensions/Abmessungen/Medidas

205x226 cm	(140x200 cm)*
221x226 cm	(160x200 cm)*
235x226 cm	(170x200 cm)*
240x226 cm	(180x200 cm)*

\* Dimensioni del materasso/Mattress sizes/ Dimensions du matelas/ Abmessungen der Matratze/Medidas del colchón



prévus les mesures pour des matelas de 210 cm. et 220 cm de longueur et il est possible de couvrir complètement le dos de la tête de lit avec le même tissu ou cuir que le lit.

**Betten mit einzelner oder getrenntem Lattenrost**  
Stahl-Füße und Stützfläche bezogen mit Kernleder pigmentato 90 in der derselben Farbe. Stahl-Gestell mit gebogenen Buchen-Dauben, naturfarben lackiert. Kopfteil und Unterteil mit Polyurethan/wärmegebundener Polyesterfaser gepolstert. Abnehmbarer Bezug aus Stoff oder Leder. Auf Nachfrage sind die Bett-Maßen für die Matratzen

210 cm und 220 cm lang verfügbar und kann das ganze Kopfteil in dem gleichen Stoff oder Leder des Bettes bezogen werden.

**Camas con somier unico o separado**

Patas y repisa de acero tapizados de cuero pigmentato 90 del mismo color. Estructura de acero con lamas de haya curvada, barnizado natural. Base y cabezal acolchados de poliuretano/fibra poliéster termounida. Tapizado desenfundable de tejido o de piel. Sobre pedido están disponibles las medidas de la cama para colchones de 210 cm y 220 cm de largo;

es posible tambien tapizar completamente la parte trasera del cabezal con el mismo tejido o piel de la cama.



## Design

## De Pas, D'Urbino, Lomazzi

1983

### Letto

Struttura in acciaio con doghe in faggio curvato. Piedini in acciaio nichelsatinato colore naturale o nero che permettono di ottenere diverse altezze del letto. Rivestimento sfilabile, in tessuto o pelle o non sfilabile

in cuoio. La versione in cuoio ha le cuciture in filo bianco. A richiesta è disponibile anche la misura per il materasso da 210 cm di lunghezza.

### Bed

Steel frame with bent beech strips. Steel feet, with natural or black nickel-satin finish that allow different heights of the bed. Removable fabric or leather cover, or non-removable in cowhide. The version in cowhide has

the stitching in white thread. Upon request the bed size for 210 cm. long mattress is also available.

### Lit

Structure en acier avec douves en hêtre courbé. Pieds en acier nickel satiné, dans les couleurs naturel ou noir que permettent d'obtenir différentes hauteurs du lit. Revêtement déhoussable, en tissu ou cuir ou non

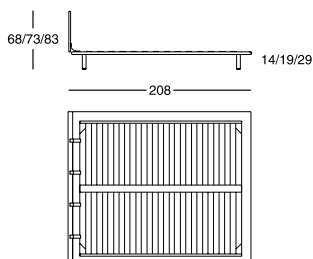

### Dimensioni/Sizes/Dimensions/ Abmessungen/Medidas

93x208 cm	(90x200 cm)*
143x208 cm	(140x200 cm)*
163x208 cm	(160x200 cm)*
183x208 cm	(180x200 cm)*
203x208 cm	(200x200 cm)*

\* Dimensioni del materasso/Mattress sizes/ Dimensions du matelas/ Abmessungen der Matratze/Medidas del colchón





déhoussable en cuir sellier. La version en cuir sellier a les coutures en fil blanc. Sur demande, il est prévu aussi la mesure pour un matelas de 210 cm de longueur.

**Bett**  
Stahlgestell mit Lattenrost aus gebogenen Buchen-Dauben. Füße aus Stahl mit naturfarben- oder schwarz- vernickeltem und mattiertem Finish, die verschiedene Betthöhen erlauben. Abnehmbarer

Bezug aus Stoff oder Leder oder nicht abziehbares aus Kernleder. Die Nähte der Kernlederausführung sind weiß. Auf Nachfrage ist die Bett- Maße für die Matratze 210 cm lang auch verfügbar.

**Cama**  
Estructura de acero con lamas de haya curvadas. Pies de acero niquelado mate en los acabados natural o negro que permiten diferentes alturas de la cama. Tapizado de tejido o de piel, desenfundable, o de cuero,

fijo. La versión en cuero tiene las costuras en hilo blanco. Sobre pedido está también disponible la medida de la cama para el colchón de 210 cm de largo.

Piedini/Feet/Pieds/Füße/Patas



# Milleunanotte <sup>1603</sup>



Design

Emaf Progetti

2006

## Letto con struttura a baldacchino

Struttura smontabile in legno impiallacciato in rovere verniciato naturale o tinto grigio. Molleggio in doghe di faggio curvato, con regolatori di rigidità. Testiera imbottita in poliuretano/fibra poliestere termolegata. Rivestimento sfilabile in stoffa o in pelle. A richiesta è disponibile anche la misura per il materasso da 210 cm di lunghezza.

## Four-poster bed with canopy

Demountable wooden frame either veneered with natural or grey vanished oak. Suspension in bent beech strips, with stiffness adjusters. Headboard upholstered in polyurethane/heat-bound polyester fibre. Removable fabric or leather cover. Upon request the bed size for 210 cm. long mattress is also available.

## Lit avec structure à baldaquin

Structure démontable, en bois contreplaqué en rouvre, couleur naturelle ou teinté gris. Suspension en douves de hêtre courbé, couleur naturelle, avec régulateurs de rigidité. Tête de lit rembourré en polyuréthane/fibre polyester liée à chaud. Revêtement déhoussable en tissu ou en cuir. Sur demande, il est prévu aussi la mesure pour un matelas de 210 cm de longueur.

## Himmelbett

Zerlegbares Gestell aus Holz, mit naturfarben oder grau-gebeizter Eiche furniert. Lattenrost aus gebogenen Buchen-Dauben, in der Nachgiebigkeit regulierbar. Kopfteil-Polsterung aus Polyurethan/wärmegebundener Polyesterfaser. Abnehmbarer Bezug aus Stoff oder Leder. Auf Nachfrage ist die Bett-Maße für die Matratze 210 cm lang auch verfügbar.

## Cama con dosel

Estructura desmontable de madera contrachapada de roble pintado natural o teñido gris. Somier de lamas de haya curvadas, con reguladores de rigidez. Cabezal acolchado de poliuretano/fibra poliéster termounida. Tapizado desenfundable de tejido o de piel. Sobre pedido está también disponible la medida de la cama para el colchón de 210 cm de largo.

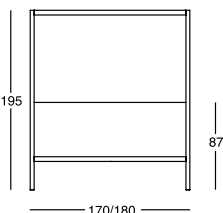

### Struttura/Frame/Structure/Gestell/Estructura

Rovere naturale/Natural oakwood/  
Rouvre naturel/Naturfarbene Eiche/  
Roble natural



Rovere tinto grigio/Grey varnished oak/  
Rouvre teinté gris/Grau gebeizte Eiche/  
Roble teñido gris



### Dimensioni/Sizes/Dimensions/ Abmessungen/Medidas

170x210 cm (160x200 cm)\*  
180x210 cm (170x200 cm)\*

\* Dimensioni del materasso/Mattress  
sizes/Dimensions du matelas/  
Abmessungen der Matratze/Medidas  
del colchón



Design

Emaf Progetti

2010

## Letti

Struttura smontabile in acciaio verniciato, colore nero o bianco. Molleggio in doghe di faggio curvato con regolatori di rigidità. La versione 1707 è dotata di cuscini testiera in piuma d'oca - materiale 100% vergine con inserto in poliuretano. Rivestimento sfilabile in stoffa o pelle (solo per il mod. 1707). A richiesta è disponibile anche la misura per il materasso da 210 cm di lunghezza.

## Beds

Demountable steel frame painted in the shade of black or white. Springing in bent beech strips, with stiffness adjusters. Version 1707 has headboard cushions with goose down - 100% pure material, with polyurethane insert. Removable fabric or leather cover (only for model 1707). Upon request the bed size for 210 cm. long mattress is also available.

## Lits

Structure démontable en acier laqué, noire ou blanche. Suspension en douves de hêtre courbé, avec régulateurs de rigidité. Dans la version 1707, les coussins à la tête du lit sont en plumes d'oie - matériau 100 % vierge, avec insert en polyuréthane. Revêtement déhoussable en tissu ou en cuir (seulement pour le modèle 1707). Sur demande, il est prévu aussi la mesure pour un matelas de 210 cm de longueur.

## Betten

Zerlegbares Gestell aus weiß oder schwarz lackiertem Stahl. Lattenrost aus gebogenen Buchen-Dauben, in der Nachgiebigkeit regulierbar. Bei der Ausführung 1707 sind die Kissen des Kopfteils mit 100% reinen Gänsedaunen gefüllt, mit Einlage aus Polyurethan. Abnehmbarer Bezug aus Stoff oder Leder (nur fürs Modell 1707). Auf Nachfrage ist die Bett-Maße für die Matratze 210 cm lang auch verfügbar

## Camas

Estructura desmontable de acero barnizado, color negro o blanco. Somier con lamas de haya curvadas, con reguladores de rigidez. La versión 1707 está dotada de cojines de cabecal en plumón de ganso - material 100% virgen con inserción de poliuretano. Tapizado desenfundable en tejido o piel (solo por el modelo 1707). Sobre pedido está también disponible la medida de la cama para el colchón de 210 cm de largo.

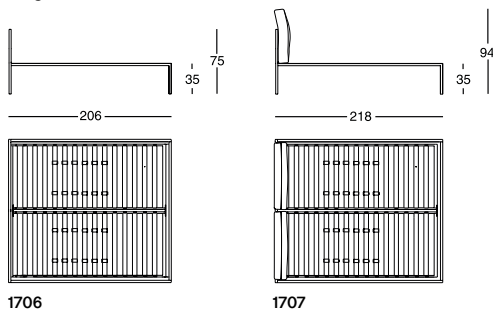

1706

1707

Piedini/Feet/Pieds/FüÙe/Patas



## Dimensioni/Sizes/Dimensions/Abmessungen/Medidas

Mod. 1706		Mod. 1707	
96x206 cm	(90x200 cm)*	96x218 cm	(90x200 cm)*
146x206 cm	(140x200 cm)*	146x218 cm	(140x200 cm)*
166x206 cm	(160x200 cm)*	166x218 cm	(160x200 cm)*
186x206 cm	(180x200 cm)*	186x218 cm	(180x200 cm)*
206x206 cm	(200x200 cm)*	206x218 cm	(200x200 cm)*

\* Dimensioni del materasso/Mattress sizes/Dimensions du matelas/Abmessungen der Matratze/Medidas del colchón



Design

Spalvieri & Del Ciotto

2020

#### Letti con rete unica o separata

Struttura testiera in rovere naturale o verniciato a poro aperto colore nero. Imbottitura in poliuretano/fibra poliestere termolegata. Piedi anteriori e asta superiore testiera in acciaio verniciato colore nero opaco. Rivestimento sfilabile in

stoffa o pelle. Struttura base in acciaio con doghe in faggio curvato verniciato naturale. A richiesta è disponibile anche la misura per il materasso da 210 cm di lunghezza.

#### Beds with single or separate springing

Headboard frame in natural or in black open pore painted oak. Upholstery in polyurethane/heat-bound polyester fibre. Front feet and headboard upper rod in matt black varnished steel. Removable fabric or leather cover. Steel base with natural

bent beech strips. Upon request the bed size for 210 cm long mattress.

#### Lits avec sommier single ou séparé

Structure tête et pied du lit en rouvre naturel ou verni à pore ouvert, dans la couleur noire. Rembourrage en polyuréthane/fibre polyester liée à chaud. Pieds avant et tête de lit supérieure en acier peint en noir mat. Revêtement déhoussable

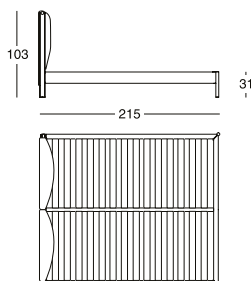

#### Dimensioni/Sizes/Dimensions/Abmessungen/Medidas

173x215 cm	(160x200)*
183x215 cm	(170x200)*
193x215 cm	(180x200)*

\* Dimensioni del materasso/Mattress sizes/ Dimensions du matelas/ Abmessungen der Matratze/Medidas del colchón

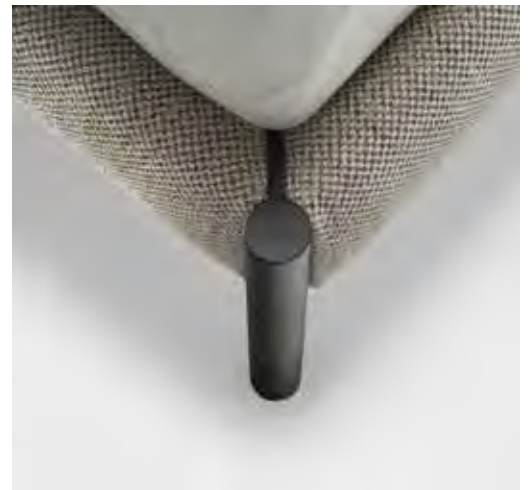
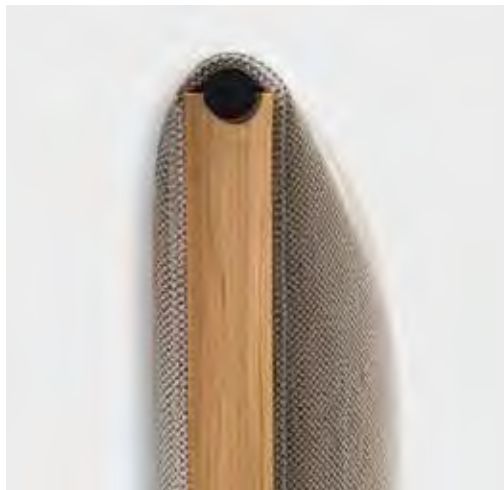

en tissu ou en cuir. Structure en acier avec douves en hêtre courbé verni naturel. Sur demande il est possible de commander le lit pour le matelas en longueur de 210 cm.

**Betten mit einzelner oder getrenntem Lattenrost**  
Kopfteil aus naturfarbener oder schwarz lasierter Eiche. Polsterung aus Polyurethan/wärmegebundener Polyesterfaser. Vordere Füße und obere Stange des Kopfteils aus matten schwarz lackiertem Stahl. Abnehmbarer Bezug aus

Stoff oder Leder. Unterteil-Gestell aus Stahl mit Lattenrost aus gebogenen Buchen-Dauben, naturfarben lackiert. Auf Nachfrage sind die Bett-Maße für die Matratze 210 cm lang verfügbar.

**Cama con somier unico o separado**  
Estructura cabezal y pies en roble natural o lacado a poro abierto color negro. Acolchado de poliuretano/fibra de poliéster termounida. Patas anteriores y varilla superior del cabezal en acero pintado color negro mate. Tapizado desenfundable de

tejido o piel. Estructura de acero con lamas de haya curvada, barnizado natural. Sobre pedido la cama puede realizarse para alojar un colchón de 210 cm de largo.

**Struttura/Frame/Structure/Gestell/Estructura**

Rovere naturale/Natural oakwood/  
Rouvre naturel/Naturfarbene Eiche/  
Roble natural

Rovere tinto nero/Black varnished oak/  
Rouvre teinté noir/Schwarz-gebeizte  
Eiche/Roble teñido negro





Design

Damian Williamson

2011

**Letti con rete unica o separata**

Piedini in lega di alluminio lucidato o nichel-satinato colore naturale o nero, oppure verniciato nero. Struttura in acciaio con doghe in faggio curvato. Imbottitura testiera in poliuretano/fibra poliestere termolegata. Rivestimento

sfilabile in stoffa o pelle. A richiesta sono disponibili anche le misure per i materassi da 210 e 220 cm di lunghezza.

**Beds with single or separate springing**

Polished or black painted aluminium alloy feet, or with natural or black nickel-satin finish. Steel frame with suspension in bent beech strips. Headboard upholstered with polyurethane/heat-bound polyester fibre. Removable

fabric or leather cover. Upon request the bed sizes for 210 cm. and 220 cm. long mattresses are also available.

**Lits avec sommier single ou séparé**

Pieds en alliage d'aluminium poli ou nickel satiné, dans les couleurs naturel ou noir, ou verni noir. Structure en acier avec douves en hêtre courbé. Rembourrage de la tête de lit en polyuréthane/fibre polyester liée à chaud. Revêtement déhoussable

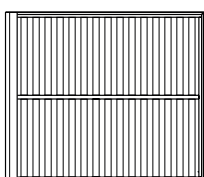
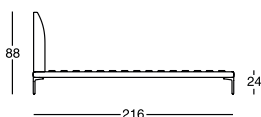

1883

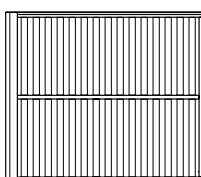

1884



en tissu ou en cuir. Sur demande, ils sont prévus aussi les mesures pour des matelas de 210 cm. ou 220 cm. de longueur.

**Betten mit individuelm oder getrenntem Lattenrost**

Füße aus polierter oder schwarz-lackierter Aluminiumlegierung oder mit naturfarben- oder schwarz-vernickeltem und mattiertem Finish. Stahlgestell mit gebogenen Buchen-Dauben. Kopfteilpolsterung aus Polyurethan/ wärme-

gebundener Polyesterfaser. Abnehmbarer Bezug aus Stoff oder Leder. Auf Nachfrage sind die Bett-Maßen für die Matratzen 210 cm und 220 cm lang auch verfügbar.

**Cama con somier unico o separado**

Pies de aleación de aluminio pulido o niquelado mate en los acabados natural o negro, o pintado negro. Estructura de acero con lamas de haya curvada. Cabezal acolchado de poliuretano/ fibra poliéster termounida. Tapizado desenfundable, de

tejido o de piel. Sobre pedido están también disponibles las medidas de la cama para colchones de 210 cm y 220 cm de largo.

**Dimensioni/Sizes/Dimensions/Abmessungen/Medidas**

166x216 cm (160x200 cm)\*  
176x216 cm (170x200 cm)\*  
186x216 cm (180x200 cm)\*  
206x216 cm (200x200 cm)\*

\* Dimensioni del materasso/Mattress sizes/ Dimensions du matelas/ Abmessungen der Matratze/Medidas del colchón

**1883**  
piedino h. 17,5 cm  
foot h. 17,5 cm  
pied h. 17,5 cm  
Fuß h. 17,5 cm  
pie h. 17,5 cm

**1884**  
piedino h. 27,5 cm  
foot h. 27,5 cm  
pied h. 27,5 cm  
Fuß h. 27,5 cm  
pie h. 27,5 cm

Piedini/Feet/Pieds/Füße/Patas



# Confortevole <sup>1890/1891</sup>

Materasso a molle insacchettate con automodellante/Pocket sprung mattress with memory foam/Matelas à ressorts ensachés avec auto-moulant/Selbstmodellierende Matratze mit Taschenfedern/Colchón de muelles ensacados con auto-amoldante

Dimensioni/Sizes/Dimensions/  
Abmessungen/Medidas

80x200 cm  
85x200 cm  
90x200 cm  
100x200 cm  
140x200 cm  
160x200 cm  
170x200 cm  
180x200 cm  
200x200 cm

1890 - h 20 cm  
1891 - h 30 cm

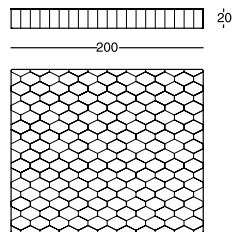

# Formaplus <sup>1889</sup>

Materasso automodellante/Memory foam mattress/Matelas auto-moulant/Selbstmodellierende Matratze/Colchón auto-amoldante

Dimensioni/Sizes/Dimensions/  
Abmessungen/Medidas

80x200 cm  
85x200 cm  
90x200 cm  
100x200 cm  
140x200 cm  
160x200 cm  
170x200 cm  
180x200 cm  
200x200 cm

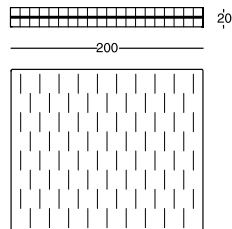

# Mollaplus <sup>1887</sup>

Materasso a molle insacchettate/Pocket sprung mattress/Matelas à ressorts ensachés/Matratze mit Taschenfedern/Colchón de muelles ensacados

Dimensioni/Sizes/Dimensions/  
Abmessungen/Medidas

80x200 cm  
85x200 cm  
90x200 cm  
100x200 cm  
140x200 cm  
160x200 cm  
170x200 cm  
180x200 cm  
200x200 cm

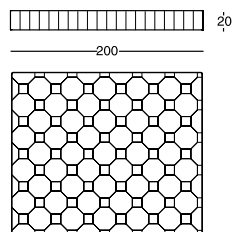

# Molleggio <sup>1886</sup>

Materasso a molle/Spring mattress/Matelas à ressorts/Matratze mit Stahlfedern/Colchón de muelles

Dimensioni/Sizes/Dimensions/  
Abmessungen/Medidas

90x200 cm  
140x200 cm  
160x200 cm  
170x200 cm  
180x200 cm  
200x200 cm

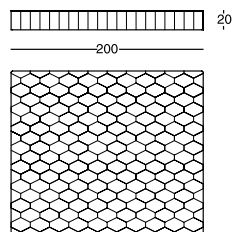

# Natura <sup>1893</sup>

Materasso in lattice/Latex mattress/Matelas en latex/Latex-Matratze/Colchón de látex

Dimensioni/Sizes/Dimensions/  
Abmessungen/Medidas

80x200 cm  
85x200 cm  
90x200 cm  
100x200 cm  
140x200 cm  
160x200 cm  
170x200 cm  
180x200 cm  
200x200 cm

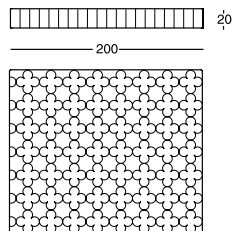

# Topper <sup>1898</sup>

Materassino aggiuntivo per materassi/Mattress topper/Petit matelas d'appoint pour matelas/Matratzenauflage für normale Matratzen/Colchoncillo adicional para colchones

Dimensioni/Sizes/Dimensions/  
Abmessungen/Medidas

80x200 cm  
85x200 cm  
90x200 cm  
100x200 cm  
140x200 cm  
160x200 cm  
170x200 cm  
180x200 cm  
200x200 cm

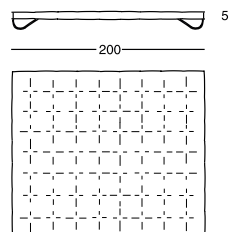





Guanciaie in Hollofil/ Hollofil pillow/ Oreiller en Hollofil/  
Hollofil Kissen/ Almohada de Hollofil

Guanciaie in piuma/ Feather pillow/ Oreiller en plume/  
Daunenkissen/ Almohada de pluma

Guanciaie automodellante cervicale/Wave-shaped  
memory foam pillow/Oreiller auto-moulante à deux ondes/  
Selbstmodellierendes Kissen mit zwei Erhebungen/  
Almohada auto-amoldante con doble ola

Guanciaie in lattice cervicale/Wave-shaped latex pillow/  
Oreiller en latex à deux ondes/Kissen aus Latex mit zwei  
Erhebungen/Almohada de látex con doble ola

Guanciaie in lana/Wool pillow/Oreiller en laine/Kissen aus  
Wolle/Almohada de lana

Guanciaie automodellante saponetta/Soap-shaped memory  
foam pillow/Oreiller auto-moulante en forme de savon/  
Selbstmodellierendes Kissen seifenförmig/Almohada auto-  
amoldante de forma tradicional



Complimenti  
d'arredo  
Furnishing  
accessories  
Compléments  
d'ameublement  
Wohnaccessoires  
Complementos  
de decoracion

178–205

# Albero<sup>400</sup>



Design

Achille Castiglioni

1983

**Portavasi con piani rotanti**

Struttura in acciaio verniciato nei colori bianco, nero, amaranto o verde. Piattelli portavasi in poliammide, colore nero. Piedini in polipropilene colore nero.

**Rotating flowerpot stand**

Painted steel frame in the shades black, white, amaranth or green. Pot-holder dishes in black polyamide. Black polypropylene feet.

**Jardinière à plateau tournant**

Structure en acier verni dans les couleurs blanc, noir, amarante ou vert. Petits plats en polyamide, couleur noire. Pieds en polypropylène noir.

**Blumenständer mit drehbaren Ablagen**

Gestell aus lackiertem Stahl, in den Farben weiß, schwarz, Amaranthrot oder grün. Polyamid-Untersetzer, schwarzfarben. Füße aus schwarzem Polypropylen.

**Macetas con patas giratorias**

Estructura en acero pintado en los colores blanco, negro, granate o verde. Platos porta-macetas en poliamida color negro. Patas en polipropileno negro.

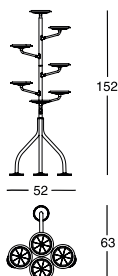

Struttura/Frame/Structure/ Gestell/Estructura



# Allunaggio <sup>230</sup>



Design

Achille e Pier Giacomo Castiglioni

1965

IN/OUT

**Sedile per esterni**

Gambe in acciaio, sedile in lega di alluminio, verniciati colore verde prato. Piedini in polietilene, colore naturale.

**Outdoor stool**

Steel legs, aluminium alloy seat painted grass green. Natural polyethylene feet.

**Siège pour extérieurs**

Pieds en acier, siège en alliage d'aluminium, vernis vert pré. Pieds en polyéthylène, couleur naturelle.

**Stuhl fürs Freie**

Beine aus Stahl, Sitz aus Aluminiumlegierung, grasgrün lackiert. Fußenden aus naturfarbenem Polyäthylen.

**Taburete para exteriores**

Patas de acero, asiento de aleación de aluminio, pintados de color verde prado. Pies de polietileno de color natural.

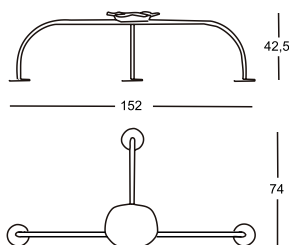

# Aster<sup>303</sup>



Design

Alessandro Dubini

2010

**Appendiabiti**

Struttura in acciaio verniciato, colore bianco, nero o rosso.

**Clothes stand**

Steel frame painted white, black or red.

**Portemanteaux**

Structure en acier vernie blanche, noire ou rouge.

**Kleiderständer**

Gestell aus weiß, schwarz oder rot lackiertem Stahl.

**Colgador**

Estructura de acero barnizado de color blanco, negro o rojo.

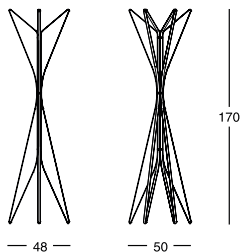

Struttura/Frame/Structure/ Gestell/Estructura



# Chichibio <sup>340</sup>



Design

G. Levi Montalcini, G. Pagano Pogatschnig

1932

**Portaoggetti**

Struttura in tubo di acciaio cromato. Pianetti in laminato plastico stratificato, colore bianco/nero, reversibile.

**Objects stand**

Chromium-plated, tubular steel frame. Shelves in reversible black/white plastic laminate.

**Porte-objets**

Structure en tube d'acier chromé. Plateaux en laminé plastique stratifié, couleur blanche/noire, réversible.

**Ständer für Gegenstände**

Gestell aus verchromtem Stahlrohr. Platten aus Schichtpress-Stoff Laminat, weiß/schwarz, umkehrbar.

**Porta objetos**

Estructura tubular de acero cromado. Estantes de laminado plástico estratificado, color blanco/negro, reversible.

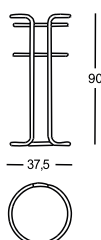



Design

Giuseppe Terragni

1934

**Poltroncina**

Sedile e schienale colore nero. Balestre di sostegno schienale in acciaio inox 18/8.

**Chair**

Black seat and back. 18/8 stainless steel backrest support spring.

**Petit fauteuil**

Siège et dossier couleur noire. Ressort de soutien en acier inox 18/8.

**Stuhl**

Sitzfläche und Rückenlehne schwarz. Federbogen der Rückenlehne aus Inox- Stahl 18/8.

**Butaquita**

Asiento y respaldo de color negro. Elementos de soporte respaldo de acero inox 18/8.

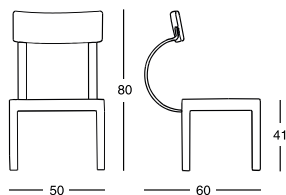





Design

De Pas, D'Urbino, Lomazzi

1975

**Sgabello**

Struttura in faggio, colore naturale, con crociera rossa. Sedile girevole e regolabile in altezza.

**Stool**

Natural varnished beech frame with red bracket. Vertically adjustable revolving seat.

**Tabouret**

Structure en hêtre naturel avec croisillon rouge. Assise tournante et réglable en hauteur.

**Hocker**

Struktur aus Buche, naturfarben, mit rotem Kreuz. Drehbarer Sitz, höhenverstellbar.

**Taburete**

Estructura de haya natural con cruceta en rojo. Asiento giratorio y regulable en altura.

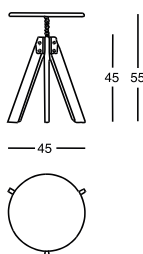



Design

Achille Castiglioni

1989

#### Libreria a ripiani rotanti

Piani in medium density fiberboard, verniciatura gofrata antigraffio nei colori bianco, nero o bordeaux. Snodi portanti in acciaio verniciato nero nelle versioni nera o bordeaux oppure bianco nella versione bianca. Il mobile è disponibile nella versione a cinque o a sette ripiani.

#### Rotating shelf bookcase

Uprights and shelves in medium density fiberboard, finished with scratch-resistant embossing in white, black or burgundy. Steel articulated joints painted black for the models black or burgundy, or in the shade white for the white model. The shelf unit is available with either five or seven shelves.

#### Bibliothèque avec étagères pivotantes

Éléments en medium density fiberboard avec vernissage gaufré anti rayures dans le couleur blanc, noir ou bordeaux. Articulations porteuses en acier verni noir dans les versions noire ou bordeaux ou verni blanc pour la version blanche. Le meuble est disponible dans la version avec cinq ou sept étagères.

#### Bücherregal mit Drehregalen

Platten aus Medium Density Fiberboard, kratzfest gaufriert lackiert in den Farben weiß, schwarz oder burgunderrot. Gelenk-Stützen aus schwarz lackiertem Stahl für die Modelle in den Farben schwarz oder burgunderrot; oder weiß lackiert für die weiße Version. Das Drehregal ist in zwei Versionen lieferbar, bzw. mit fünf oder sieben Platten.

#### Biblioteca con estantes giratorios

Estantes de MDF lacado en relieve anti-rasguño en los colores blanco, negro o burdeos. Articulaciones portantes de acero pintado negro por las versiones en negro o burdeos, o blanco por la versión en blanco. El mueble está disponible con cinco o siete estantes.

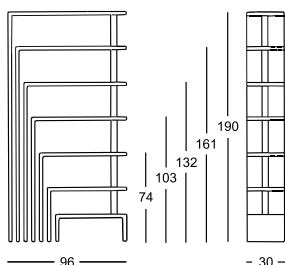

Snodo/Articulated joint/Articulation/  
Verbindungsstück/Articulación



Piani/Shelves/Plateaux/Platten/  
Estantes



# Mezzadro <sup>220</sup>



Design

Achille e Pier Giacomo Castiglioni 1957

## Sgabello

Gambo in acciaio cromato. Sedile verniciato nei colori: arancio, rosso, giallo, bianco o nero. Base in faggio evaporato, colore naturale.

## Stool

Chromium-plated steel stem. Seat lacquered in the colours: orange, red, yellow, white or black. Footrest in steam-treated beech, natural colour.

## Tabouret

Pied en acier chromé. Siège verni dans les couleurs: orange, rouge, jaune, blanc ou noir. Base en hêtre évaporé, couleur naturelle.

## Hocker

Stützstange aus verchromtem Stahl. Sitz lackiert orange, rot, gelb, weiß oder schwarz. Fuß aus gedampfter Buche, naturfarben.

## Taburete

Pata de acero cromado. Asiento pintado en los colores: rojo, naranja, amarillo, blanco o negro. Base de haya vaporizada, color natural.

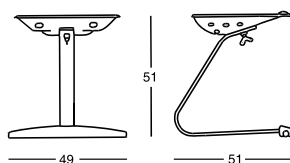

# Milo CM<sup>465</sup>



Omaggio a

Carlo Mollino

1938

## Specchio

Silhouette della Venere di Milo in cristallo con nottolino in acciaio inox per il fissaggio a parete.

## Mirror

Venus de Milo's silhouette plate glass, with stainless steel pawl for hanging.

## Miroir

Silhouette de la Venus de Milo en verre avec attache en acier inox pour l'accrochage au mur.

## Spiegel

Silhouette der Venus von Milo aus Kristallglas. Aufhängung aus Inox-Stahl.

## Espejo

Silueta de la Venus de Milo de cristal con pletinas de acero inox para colgar el espejo a la pared.





Design

Enzo Mari

1991

**Appendiabiti a muro**

Elemento singolo in acciaio verniciato antigraffio, colore nero o bianco.

**Coat hanger**

Single steel element painted black or white with scratch resistant finish.

**Porte-manteaux a mur**

Élément single en acier verni anti rayures, couleur noire ou blanche.

**Wandgarderobe**

Einzelelement aus Stahl mit Anti-Kratzer-Lackierung, Farbe schwarz oder weiß.

**Perchero de pared**

Elemento colgador de acero, lacado con relieve antirasguño de color negro o blanco.

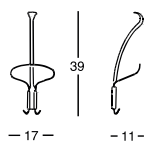

- 17 -

- 11 -



# Primate <sup>240</sup>



Design

Achille Castiglioni

1970

#### Sedile inginocchiato

Struttura in poliuretano rigido. Basamento in polistirolo, colore nero. Imbottitura in poliuretano flessibile. Gambo in acciaio inox 18/8. Rivestimento in Ecofire o pelle 95.

#### Kneeling-stool

Stiff polyurethane frame. Base in black painted polystyrene. Flexible polyurethane upholstery. 18/8 stainless steel leg. Cover in Ecofire or leather 95.

#### Siège-agenouilloir

Structure en polyuréthane rigide. Embase en polystyrène, couleur noire. Rembourrage en polyuréthane flexible. Tige en acier inox 18/8. Revêtement en Ecofire ou cuir 95.

#### Kniesitz

Gestell aus steifem Polyhurethan. Basis aus schwarzem Polystyrol. Polsterung aus flexiblem Polyhurethan. Stützstange aus Inox-Stahl 18/8. Bezug aus Ecofire oder Leder 95.

#### Asiento ergonómico

Estructura de poliuretano rígido. Base de poliestirolo, de color negro. Acolchado de poliuretano flexible. Elemento de soporte asiento de acero inox 18/8. Tapizado en Ecofire o piel 95.

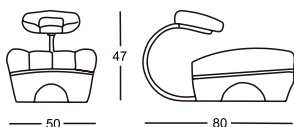

# Quaderna Carpet <sup>150</sup>

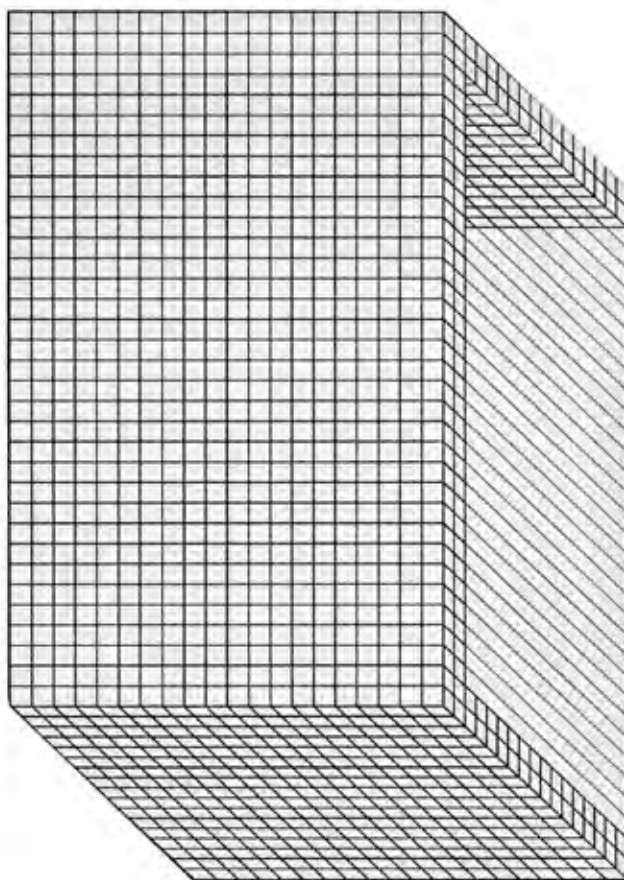
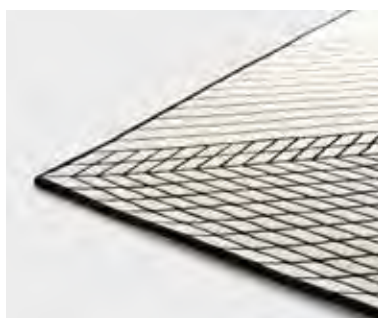

Design

Superstudio / Cristiano Toraldo di Francia

1969-1972

## Tappeto

Tappeto tuftato a mano con vello uniforme su tutta la superficie realizzato in 100% lana neozelandese. Supporto inferiore in tela 100% cotone fissata con colla in lattice 100% naturale. Bordatura perimetrale eseguita a mano con filo di lana a rifinire i sei lati. Disponibile nella dimensione 200x300 e 250x350 cm in un unico colore: fondo bianco e linee grigie e nere in linea con il disegno originale.

## Carpet

Hand-tufted carpet with uniform fleece over the entire surface made of 100% New Zealand wool. Perimeter edging finished by hand with wool thread on all six sides. Available in sizes 200x300 cm and 250x350 cm in a single colour scheme: white background and gray and black lines compliant with the original design.

## Tapis

Tapis tufté à la main avec toison uniforme sur toute la surface en laine 100% néo-zélandaise. Ordure périmétrique réalisée à la main avec du fil de laine pour finir les six côtés. Disponible en tailles 200x300 et 250x350 cm en une seule couleur: fond blanc et lignes grises et noires en ligne avec le design original.

## Teppich

Handgetufteter Teppich mit einheitlichem Vlies über die gesamte Fläche aus 100% neuseeländischer Wolle. Umfangseinfassung von Hand mit Wollfaden, um die sechs Seiten zu beenden. Erhältlich in den Größen 200x300 und 250x350 cm in einer einzigen Farbe: weißer Hintergrund und graue und schwarze Linien im Einklang mit dem ursprünglichen Design.

## Alfombra

Alfombra con copetes a mano con vellón uniforme sobre toda la superficie hecha de lana 100% neozelandesa. Soporte inferior en lona 100% algodón fijada con pegamento de látex 100% natural. Borde perimetral realizado a mano con hilo de lana para terminar los seis lados. Disponible en tamaños 200x300 y 250x350 cm en un solo color: fondo blanco y líneas grises y negras en línea con el diseño original.

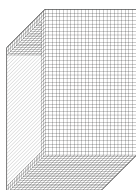

Dimensioni/  
Sizes/  
Dimensions/  
Abmessungen/  
Medidas

200 x 300 cm  
250 x 350 cm

# Quaderna Cupboard <sup>757</sup>

NEW



Design

Superstudio

1969-1972

## Madia

Struttura in legno placcato laminato Print, colore bianco, a stampa digitale a quadretti neri con interasse di 3 cm. Placcatura interna in laminato colore nero. Ripiani interni regolabili in cristallo temperato.

## Cupboard

Honeycomb core structure coated with white Print laminate, digitally printed with black squares at 3 cm spacing. Internal black laminate plating. Adjustable internal shelves in tempered plate glass.

## Armoire

Structure en panneau alvéolaire plaqué en laminé Print couleur blanche, imprimé en digital à carrés noirs avec entraxe de 3 cm. Revêtement intérieur en stratifié noir. Plateaux intérieures réglables en verre trempé.

## Schrank

Gestell aus Sperrholz mit weißem Print Laminat belegt. Digitaldruck mit kariertem Muster, Linienabstand 3 cm. Innen mit schwarzem Laminat überzogen. Verstellbare innere Regale aus gehärtetem Kristallglas.

## Aparador

Estructura de madera aplacada con laminado Print, color blanco, a impresión digital en cuadritos negros de 3 cm. Al interior esta chapado en laminado negro. Estantes interiores regulables de cristal templado.

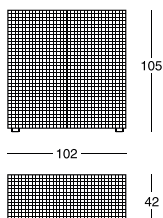



# Quaderna Sideboard <sup>756</sup>

NEW

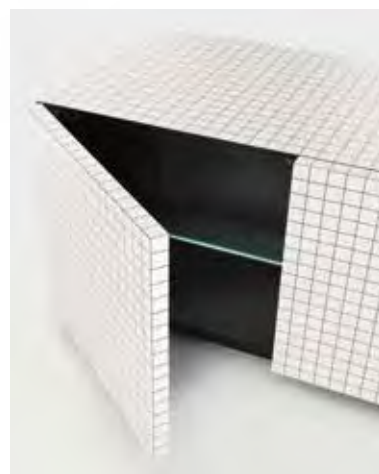

Design

Superstudio

1969-1972

## Contenitore

Struttura in legno placcato laminato Print, colore bianco, a stampa digitale a quadretti neri con interasse di 3 cm. Placcatura interna in laminato colore nero. Ripiani interni regolabili in cristallo temperato. Sullo schienale, il contenitore è dotato di aperture passacavi.

## Sideboard

Honeycomb core structure coated with white Print laminate, digitally printed with black squares at 3 cm spacing. Internal black laminate plating. Adjustable internal shelves in tempered plate glass. On the back panel, the sideboard is equipped with cable entries.

## Container de rangement

Structure en panneau alvéolaire plaqué en laminé Print couleur blanche, imprimé en digital à carrés noirs avec entraxe de 3 cm. Revêtement intérieur en stratifié noir. Plateaux intérieures réglables en verre trempé. Sur le panneau arrière, le container est équipé des ouvertures pour câbles.

## Sideboard

Gestell aus Sperrholz mit weißem Print Laminat belegt. Digitaldruck mit kariertem Muster, Linienabstand 3 cm. Innen mit schwarzem Laminat überzogen. Verstellbare innere Regale aus gehärtetem Kristallglas. Auf der Rückseite ist das Sideboard mit Öffnungen für Kabeldurchführung verstatet.

## Mueble contenedor

Estructura de madera aplacada con laminado Print, color blanco, a impresión digital en cuadritos negros de 3 cm. Al interior esta chapado en laminado negro. Estantes interiores regulables de cristal templado. En el panel trasero, el contenedor está equipado de agujeros de entrada para cables.

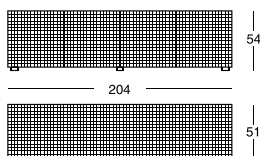

# Quaderna Mirror<sup>476</sup>

NEW

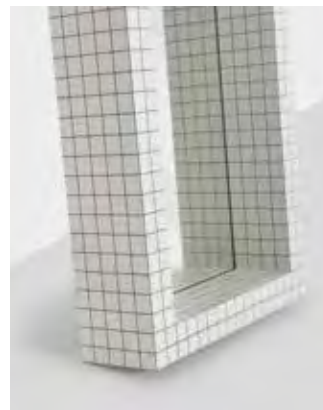

Design

Superstudio

1969-1972

## Specchio

Cristallo spessore 5 mm.  
Cornice in legno placcato  
laminato Print, colore bianco,  
a stampa digitale a quadretti  
neri con interasse di 3 cm.

## Mirror

5mm thick plate glass.  
Honeycomb core frame  
coated with white Print  
lamine, digitally printed  
with black squares at 3 cm  
spacing.

## Miroir

Cristal de 5 mm d'épaisseur.  
Cadre en panneau alvéolaire  
plaqué en laminé Print,  
couleur blanche, imprimé en  
digital à carrés noirs avec  
entraxe de 3 cm.

## Spiegel

5 mm. starkes Kristallglas.  
Rahmen aus Sperrholz mit  
weißem Print Laminat belegt.  
Digitaldruck mit kariertem  
Muster, Linienabstand 3 cm.

## Espejo

Cristal, 5 mm de espesor.  
Marco de madera aplacada  
con laminado Print, color  
blanco, a impresión digital en  
cuadritos negros de 3 cm.

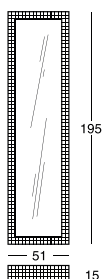

# Raperonzolo <sup>471</sup>

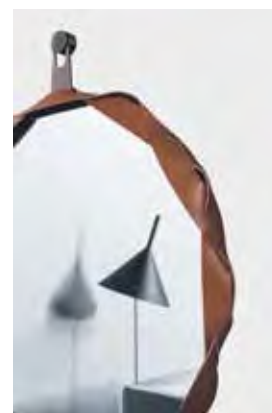

Design

Atelier Oi

2015

## Specchio

Superficie in cristallo. Il bordo dello specchio è in cuoio intrecciato colore gold accoppiato ad Alcantara® nei colori gold, blu e melanzana. Il fissaggio a parete è realizzato con una piastra in metallo bronzato.

## Mirror

Plate glass surface. The mirror outline is made of cowhide in the shade of gold, interwoven with Alcantara® in the shades gold, blue and aubergine. Wall fastening by means of a bronzed metal plate.

## Miroir

Surface en cristal. Le bord du miroir est en cuir sellier tressé dans la couleur gold couplé au Alcantara® dans les couleurs gold, bleu et aubergine. L'accrochage au mur est prévu à travers une plaque en métal bronzée.

## Spiegel

Fläche aus Glasscheiben. Der Spiegel ist mit einem Zopf aus goldfarbenen Kernlederbänder umfasst, welche mit Alcantara® bzw. in den Farben Gold, Blau und Aubergine geflochten werden. Befestigung an der Wand mittels einer Platte aus bronziertem Metall.

## Espejo

Superficie en cristal. El borde del espejo es en cuero trenzado en color gold acoplado con Alcantara® en los colores gold, azul y berenjena. Para colgar el espejo a la pared está prevista una placa en metal bronceado.

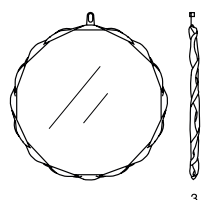

Dimensioni/  
Sizes/  
Dimensions/  
Abmessungen/  
Medidas

Ø 51  
Ø 69  
Ø 105



Design

De Pas, D'Urbino, Lomazzi

1973

**Appendiabiti chiudibile e regolabile**

Struttura in frassino tinto rovere, tinto grigio, bianco, nero o bordeaux.

**Folding and adjustable clothes stand**

Frame in natural, grey, white, black or burgundy varnished ash.

**Portemanteau pliant et réglable**

Structure en frêne teinté rouvre, teinté gris, blanc, noir ou bordeaux.

**Zusammenfaltbarer und verstellbarer Kleiderständer**

Gestell aus Esche, Eichenfarben oder grau, weiß, schwarz oder burgunderrot gebeizt.

**Perchero plegable y arreglable**

Estructura de fresno teñido roble, gris, blanco, negro o burdeos.

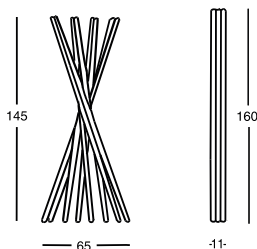

**Struttura/Frame/Structure/ Gestell/Estructura**

Frassino tinto nero/Black varnished ash/  
Frêne teinté noir/Schwarz-gebeizte Esche/  
Fresno teñido negro

Frassino tinto grigio/Grey varnished ash/  
Frêne teinté gris/  
Grau-gebeizte Esche/  
Fresno teñido gris

Frassino tinto bianco/White varnished ash/  
Frêne teinté blanc/Weiß-gebeizte Esche/  
Fresno teñido blanco

Frassino tinto rovere/Oak varnished ash/  
Frêne teinté rouvre/Eiche-gebeizte Esche/  
Fresno teñido roble

Frassino tinto bordeaux/Burgundy varnished ash/  
Frêne teinté bordeaux/  
Burgunderrot gebeizte Esche/  
Fresno teñido burdeos





Design

De Pas, D'Urbino, Lomazzi

1973-2023

**Appendiabiti chiudibile e regolabile**  
Struttura in faggio laccata multicolore. Edizione numerata.

**Folding and adjustable clothes-stand**  
Multicoloured lacquered beech frame. Numbered edition.

**Portemanteaux pliant et réglable**  
Structure en hêtre laqué multi-couleur. Édition numérotée.

**Zusammenfaltbarer und verstellbarer Kleiderständer**  
Gestell aus mehrfarbig lackierter Buche. Nummerierte Auflage.

**Perchero plegable y arreglable**  
Estructura de haya lacada multicolor. Edición numerada.

# Sella<sup>200</sup>



Design

Achille e Pier Giacomo Castiglioni

1957

**Sedile**

Sella di bicicletta da corsa, colore nero, asta in acciaio verniciato, colore rosa. Basamento in fusione di ghisa.

**Seat**

Black saddle of racing bicycle, pink lacquered steel column. Cast-iron base.

**Siège**

Selle de bicyclette de course couleur noire. Tige en acier verni couleur rose. Base en fonte.

**Sitz**

Rennradsattel Farbe schwarz. Stützstange aus lackiertem Stahl, rosa. Fuß aus Gusseisen.

**Taburete**

Sillín de bicicleta de carrera de color negro, vástago de acero pintado de rosa. Base en hierro fundido.

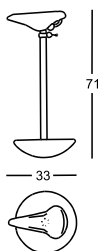

# Servento <sup>527</sup>



Design

Achille Castiglioni

della serie Servi di Achille & Pier Giacomo Castiglioni

1986

## Paravento

Base in polipropilene verniciato nero, bianco o bordeaux. Asta di sostegno in acciaio verniciato, colore nero, bianco o bordeaux. Telo in panno di lana, misure cm 66 x 150, nei colori: grigio chiaro, grigio medio, grigio scuro, rosso, giallo, carta da zucchero, mattone, verde chiaro, verde scuro o viola.

## Screen

Base in black, white, or burgundy painted polypropylene. Steel support rod, painted in the shade black, white or burgundy. Wool canvas screen, sizes cm 66 x 150, in the shades: light grey, medium grey, dark grey, red, yellow, powder blue, brick, light green, dark green or purple.

## Paravent

Base en polypropylène verni noir, blanc ou bordeaux. Tige de soutien en acier verni, noir, blanc ou bordeaux. Toile en tissu de laine, mesure 66 x 150 cm, dans les couleurs: gris clair, gris moyen, gris foncé, rouge, jaune, bleu poudre, brique, vert clair, vert foncé ou violet.

## Paravent

Fuß aus schwarz, weiß oder burgunderrot lackiertem Polypropylen. Stange aus lackiertem Stahl, in den Farben schwarz, weiß oder burgunderrot. Leinwand aus Wolle, Maße 66 x 150 cm, in den Farben: hellgrau, mittelgrau, dunkelgrau, rot, gelb, taubenblau, Backstein, hellgrün, dunkelgrün oder Veilchen.

## Separador de ambiente

Base de polipropileno pintado negro, blanco o burdeos. Asta de soporte de acero pintado, negro, blanco o burdeos. Panel en tejido de lana, medida 66 x 150 cm, en los colores: gris claro, gris medio, gris obscuro, rojo, amarillo, azul polvo, ladrillo, verde claro, verde obscuro o púrpura.

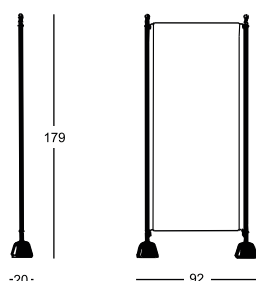

Base/Base/Base/Fuß/Base



Vello

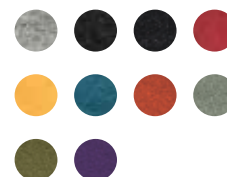

# Servostop<sup>525</sup>



Design

Achille Castiglioni

della serie Servi di Achille & Pier Giacomo Castiglioni

1984

## Transenna

Base in polipropilene verniciato nero. Asta di sostegno con gancio in acciaio verniciato, colore nero. Catena in acciaio verniciato rosso.

## Partition system

Base in black painted polypropylene. Black painted steel support rod with hook. Red painted steel chain.

## Transenne

Base en polypropylène verni noir. Tige de soutien avec crochet en acier verni noir. Chaîne en acier verni rouge.

## Absperrsystem

Fuß aus Polypropylen, schwarz lackiert. Stange mit Haken aus schwarz lackiertem Stahl. Kette aus rot lackiertem Stahl.

## Catenaria

Base de polipropileno pintado negro. Asta de soporte con gancho de acero pintado de negro. Cadena de acero barnizado rojo.

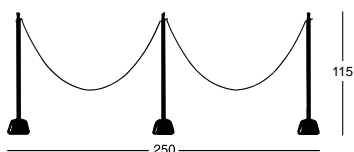



# Servobandiera <sup>515</sup>



Design

Achille Castiglioni

della serie Servi di Achille & Pier Giacomo Castiglioni

1986

IN/OUT

## Portabandiera

Base in polipropilene verniciato nero. Asta di sostegno in acciaio verniciato, colore nero per esterni. Bandiera in stamigna di lana. Colori, simboli e misure da capitolato. Misura del drappo cm 100 x 150. La bandiera svizzera misura cm 100 x 100. I simboli delle bandiere statunitense e Consiglio d'Europa sono ricamati. Disponibile anche la sola base e asta senza drappo.

## Flag-holder

Base in black painted polypropylene. Steel support rod, in the shade black for outdoor. Bunting flag. Regulation colours, symbols and sizes. Flag size cm 100 x 150, Swiss flag cm 100 x 100. On the USA and Council of Europe flags, the symbols are embroidered. Base and support rod, without cloth, are available separately.

## Porte-étendard

Base en polypropylène verni noir. Tige de soutien en acier verni couleur noire pour extérieurs. Drapeau en étamine de laine. Couleurs, symboles et mesures suivant cahier de charges. Dimensions du drapeau cm 100 x 150. Le drapeau suisse mesure cm 100 x 100. Les symboles des drapeaux américain et du Conseil d'Europe sont brodés. Nous pouvons fournir la base et la tige de soutien, sans le drapeau.

## Fahnenständer

Fuß aus Polypropylen, schwarz lackiert. Stange aus Stahl, schwarz lackiert fürs Freie. Fahne aus Wolletamin. Genormte Farben, Symbole und Maße. Maße 100 x 150 cm. Maße der Schweizer Fahne 100 x 100 cm. Die Symbole Europarats und der USA sind aufgestickt. Fuß und Stange auch ohne Fahne lieferbar.

## Portabandera

Base de polipropileno pintado negro. Asta de acero pintado de negro para exteriores. Bandera de lana. Colores, símbolos y medidas según las normas. Medidas de la bandera 100 x 150 cm. La bandera suiza mide 100 x 100 cm. Los símbolos de las banderas estadounidense y del Consejo de Europa están bordados. También suministramos solamente la base y el asta, sin bandera.

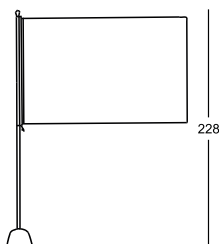

-20-

# Servonotte <sup>350</sup>

# Servietto <sup>355</sup>

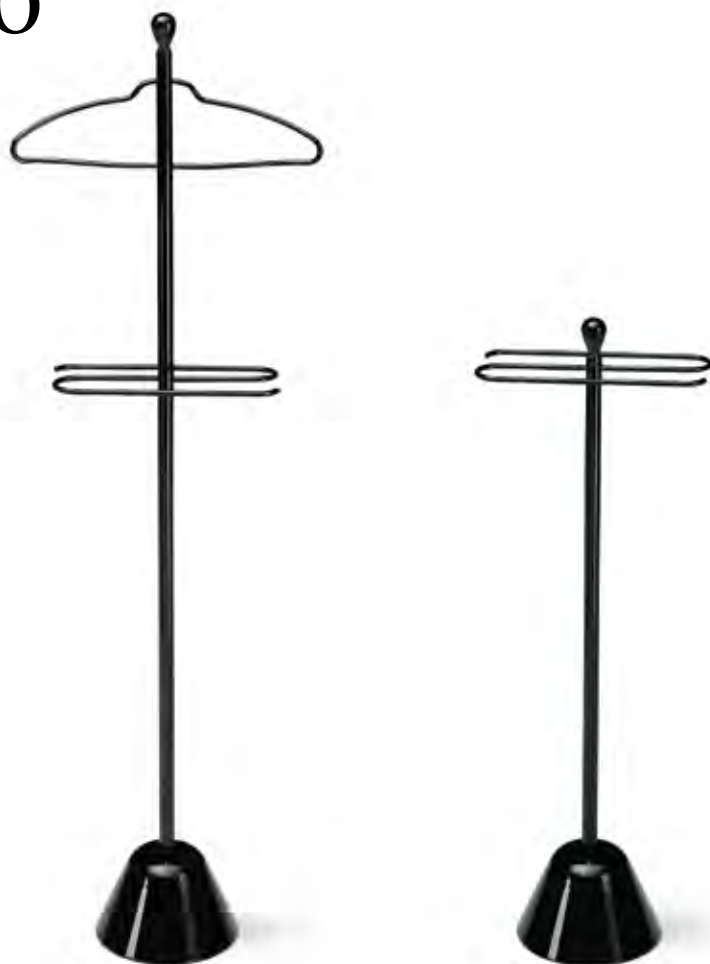

Design

Achille Castiglioni

della serie Servi di Achille & Pier Giacomo Castiglioni

1986

**Portabito/  
Portasciugamani**

Base in polipropilene e struttura verniciata in acciaio, colore nero o bianco.

**Clothes-stand/Towel-rack**

Polypropylene base and steel frame, painted in the colours: black or white.

**Valet de chambre/  
porte-serviettes**

Base en polypropylène et structure en acier verni, couleur noire ou blanche.

**Stummer Diener/  
Handtuchträger**

Fuß aus Polypropylen und Gestell aus lackiertem Stahl, schwarz oder weiß.

**Galán de noche/  
porta toallas**

Base de polipropileno y estructura de acero pintado en los colores: negro o blanco.

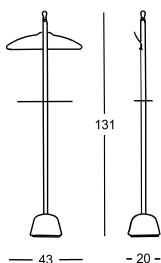

350

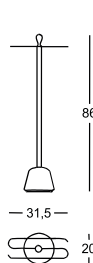

355



# Servofumo <sup>370</sup>

# Servopluvio <sup>380</sup>



Design

Achille e Pier Giacomo Castiglioni

1961

IN/OUT

**Portacenere/portaombrelli**

Base in polipropilene, vaschetta in alluminio e struttura di sostegno in acciaio verniciato, colore nero per esterni.

**Ashtray/umbrella stand**

Base in polypropylene, container in aluminium and steel support frame, black painted for outdoor.

**Cendrier/porte-parapluies**

Base en polypropylène, bassinnet en aluminium et structure de soutien en acier verni couleur noire pour extérieurs.

**Standascher/Regenschirmständer**

Fuß aus Polypropylen, Behälter aus Aluminium und tragendes Gestell aus lackiertem Stahl, schwarzfarben fürs Freie.

**Cenicero/paragüero**

Base de polipropileno, cubeta de aluminio y estructura de acero pintado, color negro para exteriores.

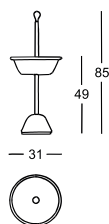

370/B

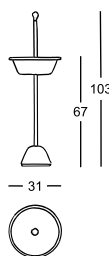

370/A

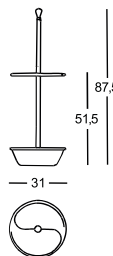

380

# Servomanto <sup>305</sup>



Design

Achille Castiglioni

della serie Servi di Achille & Pier Giacomo Castiglioni

1985

## Appendiabiti

Base in polipropilene verniciato nero o bianco. Asta di sostegno e bracci appendiabiti in acciaio verniciato, colore nero o bianco.

## Clothes stand

Base in black or white painted polypropylene. Support rod and arms in black or white painted steel.

## Portemanteaux

Base en polypropylène verni noir ou blanc. Tige de soutien et bras en acier verni noir ou blanc.

## Kleiderständer

Fuß aus Polypropylen, schwarz oder weiß lackiert. Stützstange und Arme aus schwarz oder weiß lackiertem Stahl.

## Perchero

Base de polipropileno pintado negro o blanco. Estructura de acero pintado, color negro o blanco.

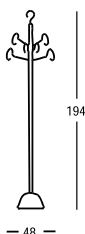

— 48 —





# Finiture/Finishes

## Verniciatura gofrata legno/Wood embossed paint/Vernissage grainé du bois/Gaufrierte Holzlackierung/Lacado rugoso de la madera

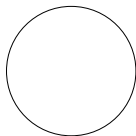

**100**  
Bianco/White/  
Blanc/Weiß/Blanco  
RAL 9016

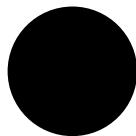

**110**  
Nero/Black/Noir/  
Schwarz/Negro  
RAL 9005



**130**  
Bordeaux/Burgundy/  
Bordeaux/  
Burgunderrot/  
Bordeos  
RAL 3005

## Laccatura lucida legno/Wood glossy lacquer/Laquage brillant du bois/Holzglanzlack/Lacado brillante de la madera

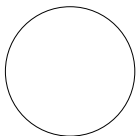

**500**  
Bianco/White/  
Blanc/Weiß/Blanco  
RAL 9016

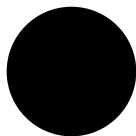

**510**  
Nero/Black/Noir/  
Schwarz/Negro  
RAL 9005



**528**  
Rosso/Red/Rouge/  
Rot/Rojo  
RAL 3003

## Laccatura poliuretano/Polyurethane lacquer/Laquage polyuréthane/Polyurethan-Lackierung/Poliuretano lacado



Alga opaco/Matt  
algae/Algues mat/  
Algen matt/Alga  
mate

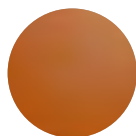

Caramello opaco/  
Matt caramel/  
Caramel mat/  
Karamell matt/  
Caramelo mate

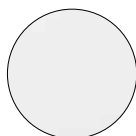

Talco opaco/Matt  
talc/Talc mat/Talkum  
matt/Talco mate



Alga metallizzato/  
Algae metallic/  
Algues métallisé/  
Metallic-Algen/Alga  
metallizada



Caramello  
metallizzato/Caramel  
metallic/Caramel  
métallisé/Metallic-  
Karamell/Caramelo  
metallizado

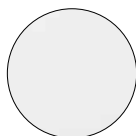

Talco lucido/Glossy  
lacquered talc/  
Talc laqué brillant/  
Talkum glänzend  
lackiert/Talco lacado  
brillante



Cristallo rivestito  
in cemento/Plate  
glass covered  
with cement/Verre  
revêtu en ciment/  
Kristallglas mit  
Zement verkleidet/  
Cristal revestido en  
cemento



Polimex® rivestito in  
cemento con finitura  
acrilica/Polimex® covered  
with acryl finish cement/  
Polimex® revêtu en ciment  
avec finition acrylique/  
Polimex® mit Zement  
verkleidet und Akryl Finish/  
Polimex® revestido en  
cemento, acabado acrílico

## Nichelsatinatura/Nickel-satin finish/Nickelage satiné/Vernickeltes Finish/Niquelado satinado



Naturale opaca/Matt  
natural/Naturel mat/  
Naturfarben mattiert  
/Natural mate



Nera opaca/Matt  
black/Noir mat/  
Schwarz mattiert/  
Negro mate



Nera lucida/Glossy  
black/Noir brillant/  
Schwarz glänzend/  
Negro brillante

## Laminato/Laminate/Laminé/Laminat/Laminado

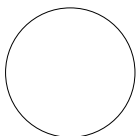

**600**  
Bianco/White/  
Blanc/Weiß/Blanco

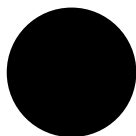

**610**  
Nero/Black/Noir/  
Schwarz/Negro



**629**  
Fenix grigio  
antracite/Anthracite  
grey Fenix/Fenix  
gris anthracite/  
Anthrazitgrau  
Fenix/Fenix gris  
antracita



**630**  
Fenix grigio chiaro/  
Light grey Fenix/  
Fenix gris clair/  
Hellgrau  
Fenix/Fenix gris claro

## Cristallo/Plate glass/Verre/Kristallglas/Cristal

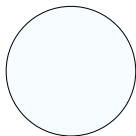

Cristallo trasparente/  
Clear plate glass/  
Verre transparent/  
Klares Kristallglas/  
Cristal transparente

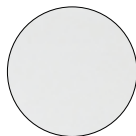

Cristallo extra chiaro  
trasparente/Extra-clear  
plate glass/Verre extra-  
clair transparent/Extra  
klares Kristallglas/Cristal  
extraclaro transparente



Cristallo fumé/Smoky  
grey plate glass/  
Verre fumé gris/  
Grau rauchfarbenes  
Kristallglas/Cristal  
gris humo



Cristallo extra chiaro acidato  
verniciato bianco/Extra-clear acidated white  
painted plate glass/Verre extra-clair  
acidifié verni blanc/Weiß lackiertes, extra  
klares und geätztes Kristallglas/Cristal  
extraclaro al ácido, barnizado blanco

## Cristalplant®

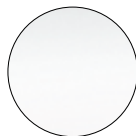

Verniciatura opaca metalli/Matt metal paint/Peinture mat métaux/  
Matte Metall-Lackierung/Pintura mate metales

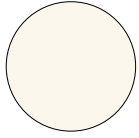

**800**  
Bianco/White/  
Blanc/Weiß/Blanco  
RAL 9016



**801**  
Azzurro acqua/Light  
blue/Bleue mer/  
Hellblau/Azul agua  
RAL 6034



**807**  
Amaranto/  
Amaranth/  
Rouge amarante/  
Amarantrot/Granate  
RAL 3011



**808**  
Verde/Green/Vert/  
Grün/Verde  
RAL 6005



**809**  
Antracite/Anthracite/  
Anthracite/Anthrazit/  
Antracita  
RAL 7012



**810**  
Nero/Black/Noir/  
Schwarz/Negro  
RAL 9005

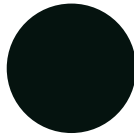

**8100**  
Nero opaco/Matt  
black/Noir mat/  
Schwarz matt/Negro  
mate  
RAL 9005



**810M**  
Nero metallizzato/  
Metallic black/Noir  
métallisé/Schwarz  
metallisiert/Negro  
metalizado  
RAL 9005



**830**  
Grafite/Graphite/  
Graphite/Graphit/  
Grafito



Rosso opaco/Matt  
red/Rouge mat/Rot  
matt/Rojo mate  
RAL 3004

Marmo/Marble/Marbre/Marmor/Marmól  
+ Pietra/Stone/Pierre/Stein/Piedra



Calacatta grigio/  
Grey Calacatta /  
Gris Calacatta/  
Grau Calacatta/Calacatta



Bianco di Carrara/  
White Carrara/  
Blanc Carrara/Weiß  
Carrara/Blanco  
Carrara



Emperador

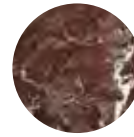

Rosso Lepanto/  
Red Lepanto/  
Rouge Lepanto/  
Rot Lepanto/Rojo  
Lepanto



Marquina

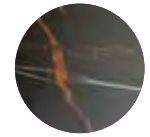

Sahara Noir

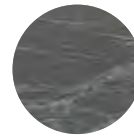

Verde Alpi/Green  
Alpi/Vert Alpi/Grün  
Alpi/Verde Alpi

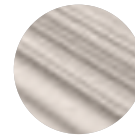

Striato Olimpico

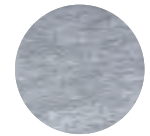

Pietra Onsernone/  
Onsernone stone/  
Pierre d'Onsernone/  
Onsernone-Stein/  
Piedra Onsernone

Essenza legno/Wood finish/Essence du bois/Holzart/Esencia de madera



Acero/Maple/  
Érable/Ahorn/Arce



Betulla/Birch/  
Bouleau/Birke/  
Abedul



Faggio naturale/  
Natural beech/  
Hêtre naturel/  
Naturfarbene Buche  
/Haya natural



Faggio evaporato/  
Steam-treated  
beech/Hêtre  
évaporé/Gedampfte  
Buche/Haya  
vaporizada



Faggio laccato  
bianco/White  
varnished beech/  
Hêtre teinté blanc/  
Weiß gebeizte  
Buche/Haya teñida  
blanco



Faggio laccato  
verde/Green  
varnished beech/  
Hêtre teinté vert/  
Grün gebeizte  
Buche/Haya teñida  
verde



Rovere naturale/  
Natural oak/  
Rouvre naturel/  
Naturfarbene Eiche/  
Roble natural



Rovere tinto grigio/  
Grey varnished oak/  
Rouvre teinté gris/  
Grau gebeizte Eiche/  
Roble teñido gris



Rovere tinto nero/  
Black varnished oak/  
Rouvre teinté noir/  
Schwarz gebeizte  
Eiche/Roble teñido  
negro



Rovere tinto noce  
Canaletto/Canaletto  
walnut dyed-oak/  
Rouvre teinté noyer  
Canaletto/Nussbaum  
Canaletto-gebeizte  
Eiche/Roble teñido  
nogal Canaletto



Frassino tinto  
bordeaux/Burgundy  
varnished ash/Frêne  
teinté bordeaux/  
Burgunderrot  
gebeiztes  
Eschenholz/Fresno  
teñido burdeos



Frassino tinto grigio/  
Grey varnished ash/  
Frêne teinté gris/  
Grau gebeiztes  
Eschenholz/Fresno  
teñido gris

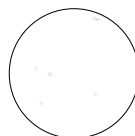

Frassino tinto  
bianco/White  
varnished ash/  
Frêne teinté blanc/  
Weiß gebeiztes  
Eschenholz/Fresno  
teñido blanco



Frassino tinto nero/  
Black varnished ash/  
Frêne teinté noir/  
Schwarz gebeiztes  
Eschenholz/Fresno  
teñido negro



Frassino tinto rovere  
naturale/Natural oak  
varnished ash/Frêne  
teinté rovere naturel/  
Naturfarbene  
Eiche gebeiztes  
Eschenholz/Fresno  
teñido roble natural

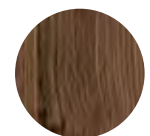

Noce Canaletto/  
Canaletto walnut/  
Noyer Canaletto/  
Nussbaum  
Canaletto/Nogal  
Canaletto

# **zanotta:**

Concept, Art direction  
**Calvi Brambilla**

Graphic design  
**Tomo Tomo**

Pre-press  
**Alt<sup>®</sup>aLuce, Milano**

Printing  
**Grafiche Antiga, 2023**

Copyright© Zanotta SpA, 2023  
All rights reserved

**Zanotta Spa**  
I – 20834 Nova Milanese  
Via Vittorio Veneto 57  
T: + 39 0362 4981  
zanottaspa@zanotta.it  
www.zanotta.com





**ALTAGAMMA**  
CREATIVITÀ E CULTURA ITALIANA

Zanotta è membro di Fondazione Altgamma che, dal 1992, riunisce i marchi dell'eccellenza italiana famosi a livello internazionale.

Zanotta is member of the Altgamma Foundation which, since 1992, has gathered together high-end Italian brands famous at international level.



Zanotta è certificata secondo le norme internazionali UNI EN ISO 9001 per i sistemi di gestione per la qualità e UNI ISO 45001 per la sicurezza e salute sui luoghi di lavoro.

Zanotta is certified according to international standards UNI EN ISO 9001 for the quality management systems and UNI ISO 45001 for the safety and health in the workplace.

Zanotta spa si riserva di apportare, senza preavviso, modifiche nei materiali, nei rivestimenti, nelle finiture e nei disegni dei prodotti presentati in questo catalogo. Le texture ed i colori dei materiali e delle finiture hanno valore indicativo in quanto soggetti alle tolleranze dei processi di stampa.

Zanotta spa reserves the right to change, without previous notice, materials, covers, finishes and drawings of the products presented in this catalogue. The textures and colours of materials and finishes are indicative as they are depending on the tolerances of the printing process.

Zanotta spa se réserve le droit d'apporter, sans préavis, des modifications au niveau des matériaux, des revêtements, des finitions et du design des produits présentés dans ce catalogue. Les textures et les couleurs des matériaux et des finitions sont une valeurs indicative parce-que ils changent selon la tolérance aux procédés d'imprimerie.

Zanotta spa behaltet sich vor, ohne Vorankündigung, Veränderungen an den Materialien, Bezügen, Finish und Zeichnungen der in diesem Katalog vorgestellten Produkte vorzunehmen. Die Texturen und Farben der Materialien und Finish haben einen hinweisenden Wert, da sie von den Toleranzen im Druckprozess abhängig sind.

Zanotta spa se reserva el derecho de aportar modificaciones de dibujo, materiales, acabados y tapicerías, sin que esté obligada a dar aviso anticipado. Las texturas y los colores de los materiales y de los acabados tienen solo un valor indicativo porque están sujetos a la tolerancia en los procesos de imprenta.

**zanotta:**



ZANOTTA SPA  
I – 20834 Nova Milanese  
Via Vittorio Veneto 57  
T: + 39 0362 4981  
[zanottaspa@zanotta.it](mailto:zanottaspa@zanotta.it)  
[www.zanotta.com](http://www.zanotta.com)