

## FitStay 6

Unlock the full potential of your hotel with the FitStay 6 Outdoor Fitness Park. Designed to inspire and motivate, this exceptional outdoor fitness facility will leave a lasting impression on your guests. Featuring a wide array of top-of-the-line exercise equipment, FitStay 6 offers a one-of-a-kind fitness experience amidst the natural beauty of your hotel surroundings.

## Attributes

Product code	1-3-240
Certificate	EN 16630, ASTM F3101
Age group	14 + years
Designed for	Hotels
Capacity	44 people
Fall height	4.592 ft

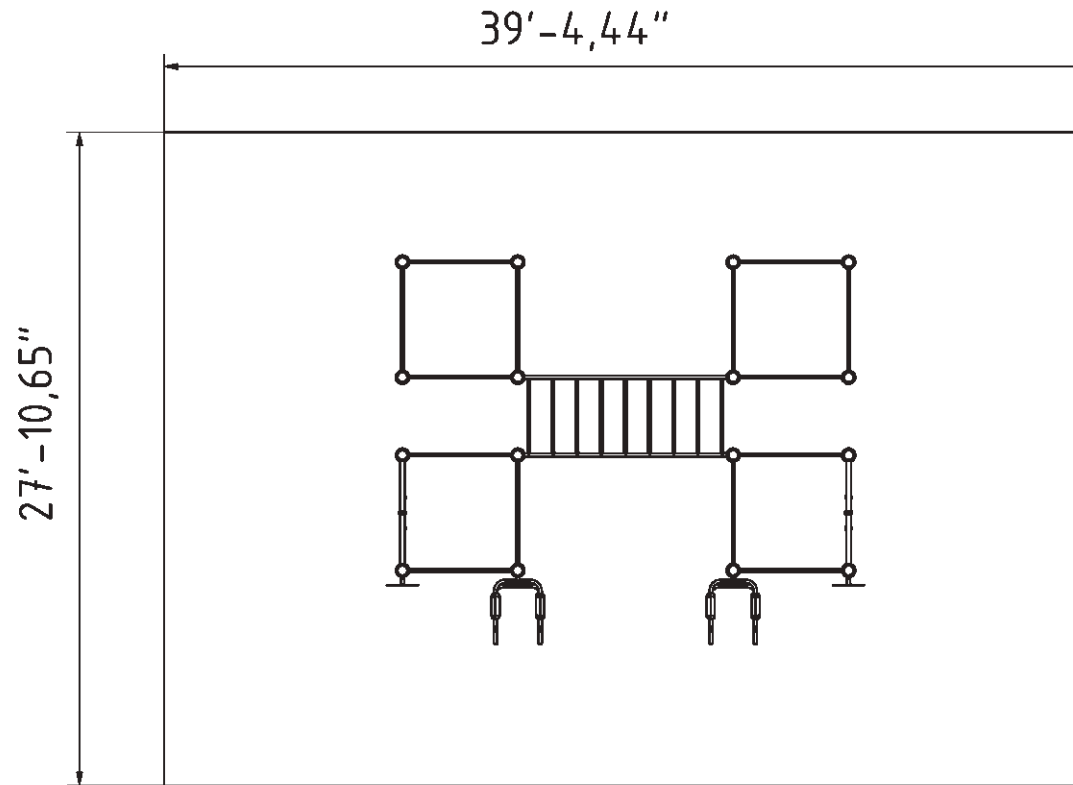

## Technical specification

Anchoring option  
 Net weight  
 Material  
 Anti-corrosion possibility  
 Total Area  
 Color options  
 For more color options, discuss with your sales representative.

In-ground or surface  
 1438 lbs  
 S235  
 Galvanized or EPD  
 1098 ft<sup>2</sup>



## Warranty

Structure  
 Steel  
 Paint  
 Plastic  
 Rubber  
 Moving parts  
 Detailed information in the warranty document

25 years  
 15 years  
 2 years  
 5-10 years  
 1-3 years  
 2 years