

FRP GRATING PRODUCT CATALOGUE



 gratingfrpaustralia.com.au

 **WA, NT & SA**
(08) 9584 2500

 wa-sales@gratingfrpaustralia.com.au

 **NSW, QLD, VIC, TAS & ACT**
(02) 4244 1008

 nsw-sales@gratingfrpaustralia.com.au

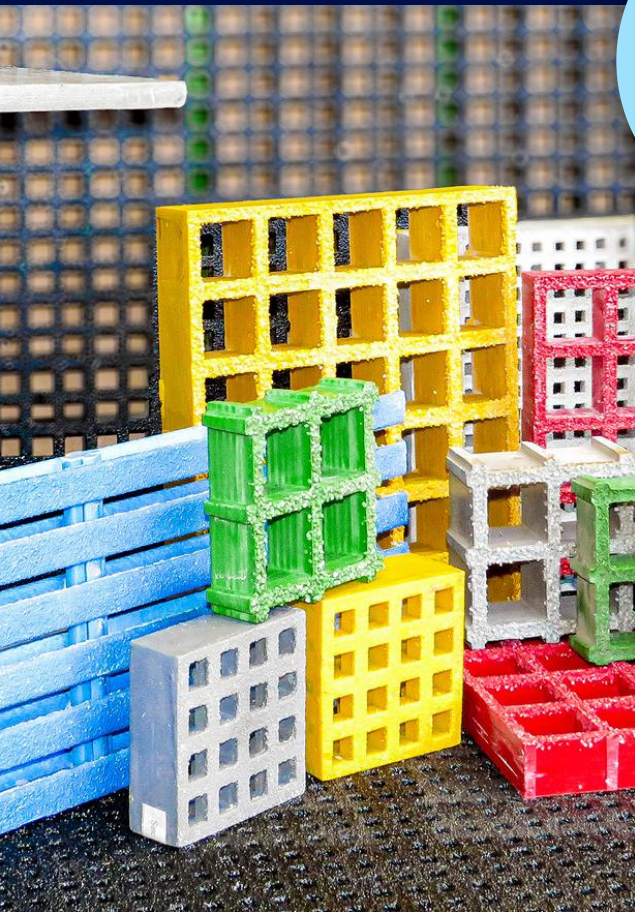



 **gratingfrp**
AUSTRALIA



Table of Contents

Managers Welcome	4
Company Overview	5 - 7
Certifications	8 - 10
About Fiber Reinforced Polymer Products	11 - 18
Molded Grating FRP Products	19 - 27
Pultruded Grating FRP Products	28 - 41
Structural Shape FRP Products	42 - 49
Anti-Slip FRP Products	50 - 53
FRP Ladders	54 - 57
FRP Hand Rails	58 - 60
Clips	61 - 62
Chemical Resistance Data Charts	63 - 65
Molded Grating Load Tables	66 - 84
Pultruded Grating Load Tables	85 - 91

Managers Welcoming

Welcome,

We are delighted to present our product catalogue for Grating FRP Australia and provide you with an insight into what makes Grating FRP Australia a leader in our field. Since our founding in 2007 by Warren Blay, who remains an integral part of our operations, we have built a robust reputation for excellence and innovation - seeing us become one of the most trusted Fibre Reinforced Polymer suppliers in Australia.

Our journey has been marked by the successful completion of over 2,500 projects nationwide. This extensive experience has allowed us to refine our expertise and maintain a consistent 5-star rating for service and product, a testament to the dedication and skill of our exceptional team. We take pride in our ability to deliver high-quality FRP products and solutions tailored to meet the diverse needs of our clients across Australia.

In this catalogue, you will find a detailed overview of our products, our industrious capabilities, and the various forms of engineering data and load tables you may require for further knowledge. Our commitment to quality, reliability, and customer satisfaction is at the core of everything we do, and we are eager to demonstrate how we can bring these strengths to your projects.

Thank you for taking the time to learn more about Grating FRP Australia. We look forward to the opportunity to collaborate and achieve great results together.

Sincerely,

Grating FRP Australia Management Team

Grating FRP Australia Management

Company Overview

We are an Australian-owned and Australia-wide specialist in industrial supplies. We have a niche focus to Fiberglass Reinforced Polymer products, structural systems and engineering services.

FACT: We are the only FRP supplier with ISO 9001 QA and BAL40 certified practices in Australia.

Grating FRP Australia supplies and designs high-quality Fiberglass Reinforced Polymer (FRP) structural products, offering a wide range of products and services. We provide fiberglass gratings, structural shapes, manhole covers, panels, access systems, stair treads, handrails, walkways, and complete structural design and fabrication for FRP projects. Our company collaborates with clients from various industries, offering technical advice and innovative FRP solutions.

Founded in 2007	We are a long-standing Australian supplier who have upheld an excellent portfolio of consumers and manufacturers over our decades of business. With an extensive track record of fabrication and installations under our belt, the fiber reinforced polymer (FRP) composites market continues to offer significant benefits to the industrial, commercial and building infrastructure in Australia and around the world.
The Leadership	At Grating FRP Australia, our leadership is characterized by a commitment to innovation, integrity, and excellence, driving our team to continually exceed expectations and pioneer new standards in the FRP industry.
Core Competency	Our core competency lies in our ability to engineer and deliver innovative FRP solutions tailored to our clients' specific needs, supported by our expertise in materials science, manufacturing processes, and industry-leading services.
The Product	Grating FRP Australia sells and supplies Fiber Reinforced Polymer products.
Innovation	At Grating FRP Australia, our innovation is evident in our customized solutions, material advancements, and sustainability initiatives. We continuously collaborate with clients and invest in research to enhance our products and processes, ensuring we deliver cutting-edge FRP solutions that meet evolving industry standards and client needs.
Research & Development	As an accredited Triple A Organization , we take pride in remaining active with our involvement of product and service development. At Grating FRP Australia, our dedicated Research and Development team collaborates on innovative projects to enhance the performance, functionality, and sustainability of our FRP products. By investing in R&D, we stay ahead of industry trends and market demands, ensuring that we deliver cutting-edge solutions tailored to our clients' evolving needs.
International Presence	Grating FRP Australia has a global presence, recognized for quality and innovation. Through strategic partnerships and collaborations, we deliver FRP solutions worldwide.

The Team



We have a full circle approach of our involvement in our team's knowledge, supply opportunities and quality controls. On a regular basis, our staff travel to our manufacturers, where we continue to ensure raw material qualities and manufacturing procedures are maintained to complete compliance, where our priorities of ethical, safe and viable services continue.

Furthermore, we work closely with Australian & Beijing Universities, in the development of new applications for FRP in conjunction with our manufacturers.

We're proudly represented by skilled and passionate staff who have extensive experience in their respected sections of our organization. We prioritise our standard of working with quality service and reliable equipment – ensuring that at all times we are providing value packed services and improvements to benefit your FRP project longevity and outcomes.

The Service



We will work alongside you to offer the complete structural design and fabrication services you require, utilising our in-house engineers. We also have the capacity to manage FRP projects at various stages to meet the project specifications and requirements you may be missing the expertise in.

We have been working with our clients from various industries across almost two decades, providing them in-depth technical advice and innovative FRP solutions that they've never looked back on.

Our supply network capacity is vast and dedicated, meaning we can source almost any specification and requirement to have a project run smoothly, efficiently and transparently from start to finish.

We offer our services all across Australasia for supply, installation, upgrades and maintenance.

The Product



We hold a large range of custom FRP product capacities and services, ranging from manhole covers, specified grating and panels, access systems, stair treads & handrails, walkway solutions, and more. Our products are a smarter choice for many applications in its durability, cost-over-lifetime, incredible strength, minimal to no need of maintenance and its non-corrosive/ non-conductive nature.

FRP has the capacity to be installed quickly, reducing labor costs. It can be transported fast and under less-freight cost due to its light weight and it is a customizable product - making it a great solution for technical structural projects.



Scavenger Fire & Safety: Certified for Quality, Safety, and Bushfire Resilience

At Scavenger Fire & Safety, we are proud to uphold the highest standards of quality, safety, and fire resistance across all our products and services. Our commitment to excellence is reflected in the following certifications:

BAL40 - Bushfire Attack Level 40

Scavenger Fire & Safety products are designed to withstand severe bushfire conditions, meeting the stringent BAL40 (Bushfire Attack Level 40) certification. This rating ensures our fire safety equipment can endure intense heat, ember attacks, and some direct flame exposure—making them ideal for use in high-risk bushfire zones. We use fire-resistant materials and construction techniques that align with Australian standards to provide maximum protection for properties in vulnerable areas.

Ashburton Assurance Australasia ISO 9001:2015 Quality Management System

Our commitment to delivering the best products is reinforced by our ISO 9001:2015 certification for quality management, provided by Ashburton Assurance Australasia. This globally recognized certification demonstrates our dedication to maintaining high-quality standards across all aspects of our operations. By focusing on customer satisfaction, continuous improvement, and effective process management, we ensure that every fire extinguisher, fire blanket, and safety solution we offer meets the most rigorous industry standards.

Ashburton Assurance Australasia ISO 45001:2018 OH&S Management System

Safety is at the core of everything we do at Scavenger Fire & Safety. Our ISO 45001:2018 certification for Occupational Health and Safety Management reflects our proactive approach to creating a safe working environment for our team and ensuring that our products contribute to the safety of others. By adhering to international safety standards, we not only minimize workplace hazards but also help safeguard our customers by delivering reliable, life-saving fire safety products.

These certifications are a testament to Scavenger Fire & Safety's unwavering commitment to protecting lives and properties. When you choose us, you're choosing a company that prioritizes quality, safety, and resilience in every product we provide.



CERTIFICATE

Material Fire Test Certificate

IGNL-6228-16C I01 R00

DATE OF TEST 30.11.2022
 ISSUE DATE 30.01.2023
 EXPIRY DATE 29.01.2028

AS 1530.8.1 Methods for fire tests on building materials, components and structures
 Part 8.1: Tests on elements of construction for buildings exposed to simulated bushfire attack – Radiant heat and small flaming sources

SPONSOR
Scavenger Supplies Pty Ltd
 15 Waverley Drive
 Unanderra NSW 2526

TEST BODY
Ignis Labs Pty Ltd
 ABN 36 620 256 617
 3 Cooper Place
 Queanbeyan NSW 2620
 Australia
 www.ignislabs.com.au
 (02) 6111 2909
 Test body is the test location



Specimen Name

FRP Grating Mini – Micro mesh

Specimen Description

The test sponsor described the FRP Grating Mini – Micro mesh as fibreglass reinforced polymer grating, which is composed of resins, isophthalic polyester. The nominal mass per unit is 18 kg/m² and the nominal thickness is 26.29 mm. The colour of the specimen is grey. The end use of it is external boardwalks and decks. The openings have a height of 12.26 mm and a width of 12.57 mm. The specimen comprised an external wall that has two layers of 6 mm fibre cements with steel framing as per Clause 8.4.1 of AS 3959-2018 and an FRP Grating MINI – MICRO Mesh decking board. Ignis Labs was not responsible for the sampling stage. All specimens were sampled by the test sponsor. The test results apply to the specimens as received.

Pre-test Conditioning

Prior to construction, the components of the specimens were subjected to normal temperatures and humidity. The crib was conditioned in an oven with temperature of between 40 °C and 50 °C for 24 hrs.

Test Method

The test was performed in accordance with the requirements of AS 1530.8.1-2007 with the purpose of determining the performance of external construction elements when exposed to radiant heat, burning embers and burning debris. Class C test cribs were prepared and used in this test in accordance with Clause 14.2 of AS 1530.8.1-2007. The furnace temperature and radiant panel was controlled so that the average heat flux, measured at the centre of the panel was maintained within the prescribed radiant heat flux limits in accordance with Table 14.2 of AS 1530.8.1-2007.

The radiant heat source was the furnace for pilot fire-resistance tests of AS 1530.4 which has a nominal size of 1 m x 1 m with a sheet steel closure. The external wall was built to have a rebate in the centre of the specimen with an eaves detail being 798 mm. The FRP Grating MINI – micro mesh deck was fabricated to fit the rebate of the external wall. The thermocouples on the eaves detail are 1070 mm above the ground.

Observations

The ambient temperature of the laboratory at the commencement of the test was 31.8 °C. The test duration was 60 minutes. Both corners of the deck rebate ignited, but no significant flame spread was observed.

Test Results

Performance Criteria	Time to failure (min)	Position of failure
Formation of through-gaps greater than 3 mm	No failure	-
Sustained flaming for 10 s on the non-fire side	No failure	-
Flaming on the fire-exposed side at the end of the 60 min test period	No failure	-
Radiant heat flux 365 mm from the non-fire side exceeding 15 kW/m ²	Not applicable	NA
Mean and maximum temperature rises greater than 140 K and 180 K	Not applicable	NA
Radiant heat flux 250 mm from the specimen, greater than 3 kW/m ² between 20 min and 60 min	Not applicable	NA
Mean and maximum temperature of internal faces exceeding 250 °C and 300 °C respectively between 20 min and 60 min after commencement of test	20 mins	The back and side sides on the crib flame bottom of the upper surface crib
Extent of flaming exceeding 500 mm limits on decking boards	No failure	-
Crib class	C	Peak heat flux 40 kW/m ²

Test Supervisor
 Darren Laker

Technical Lead
 Jessica Ying

Version: IGNL-QF-060 Issue 01 Revision 00

Disclaimer This report details methods of construction, the test conditions and the results obtained when the specific element of construction described herein was tested in accordance with test method of AS 1530.8.1. Any significant variation with respect to size, constructional details, loads, stresses, edge or end conditions, other than those allowed under the field of direct application in the relevant test method, is not covered by this report. The results of this fire test may be used to directly assess fire hazard, but it should be recognised that a single test method will not provide a full assessment of fire hazard under all fire conditions. The results only relate to the behaviour of the specimen of the element of the construction under the particular conditions of the test, they are not intended to be the sole criteria for assessing the potential fire performance of the element in use nor do they necessarily reflect the actual behaviour in fires. Because of the nature of fire hazard property testing and the consequent difficulty in quantifying the uncertainty of measurement of fire hazard properties, it is not possible to provide a stated degree of accuracy of the result.

Copyright © All rights reserved. No part of the content of this document may be reproduced, published, transmitted or adapted in any form or by any means without the written permission of Ignis Labs Pty Ltd.



ASHBURTON ASSURANCE AUSTRALASIA

Hereby grants this

**QUALITY MANAGEMENT
SYSTEM CERTIFICATION**
Registration No 610006/Q/4

to

Scavenger Supplies Pty Ltd
8 Panton Road, Greenfields WA 6210

for

**The provision of industrial, construction and maritime
supplies as well as the supply and servicing of fire
equipment.**

and in recognition of the implementation of a
management system conforming to

ISO 9001:2015

ANZSIC Code: **1090**

Certificate valid from **01/09/2022** to **03/10/2025**

Certificate Approved by Keith Jones, Managing Director

Issue Date: 01/09/2022

Initial Certification Date: 24/10/2013



This certificate of registration is granted subject to the terms of business and certification governing the scheme by Ashburton Assurance Australasia and in respect of goods and services described within the schedule hereto; at or supplied from the location/s shown on this certificate.

To verify validity of this certificate please visit www.jas-anz.org/register

ASHBURTON ASSURANCE AUSTRALASIA
LEVEL 7, 100 HAVELOCK STREET, WEST PERTH, WA





ASHBURTON ASSURANCE AUSTRALASIA

Hereby grants this

**OH&S MANAGEMENT
SYSTEM CERTIFICATION
Registration No 610006/W/2**

to

**Scavenger Supplies Pty Ltd
8 Panton Road, Greenfields WA 6210**

for

**The provision of industrial, construction and maritime
supplies as well as the supply and servicing of fire
equipment.**

and in recognition of the implementation of a
management system conforming to

ISO 45001:2018

ANZSIC Code: **1090**

Certificate valid from **01/09/2022** to **03/10/2025**

Certificate Approved by Keith Jones, Managing Director

Issue Date: 01/09/2022

Initial Certification Date: 28/06/2021



This certificate of registration is granted subject to the terms of business and certification governing the scheme by Ashburton Assurance Australasia and in respect of goods and services described within the schedule hereto; at or supplied from the location/s shown on this certificate.

To verify validity of this certificate please visit www.jas-anz.org/register

ASHBURTON ASSURANCE AUSTRALASIA
LEVEL 1, 100 HAVELOCK STREET, WEST PERTH, WA



What is FRP?

Fiber-Reinforced Polymer (FRP) (also called fiber-reinforced plastic) is a composite material made of a polymer matrix reinforced with fibers.

FRP is one of the highest strength-to-weight ratios of any material, it is strong and durable, ready for years of dependable use. Unlike steel, timber or aluminum, FRP has memory, springing back to its original shape when deflected. Even major impacts inflict little damage without failure.

FRP can also be custom designed and fabricated to provide the distinct reinforcing functions to meet the specific strength and corrosion and abrasion resistance requirements.

Types of Resin:

1. VEFR-25 & VEFR-10 (Vinyl Ester Resin):
 - VEFR-25: High chemical resistance and flame spread rating ≤ 25 . Ideal for harsh industrial environments like petrochemical plants.
 - VEFR-10: Enhanced fire resistance with a flame spread rating ≤ 10 , suitable for fire-sensitive applications.
2. IFR-25 & IFR-10 (Isophthalic Resin):
 - IFR-25: Economical, good chemical resistance, flame spread ≤ 25 , used in general industrial settings.
 - IFR-10: Higher fire retardancy with a flame spread ≤ 10 .
3. FG-30 (Food-Grade Polyester Resin):
 - Corrosion-resistant, flame spread ≤ 30 , certified for food industry use.
4. MP-5 (Phenolic Grating):
 - Exceptional fire resistance, flame spread ≤ 5 , low smoke, suitable for confined spaces.
5. Conductive Top Grating:
 - Anti-static properties for sensitive industries, dissipates static electricity safely.

These solutions deliver safety, durability, and reliability across various industrial applications.

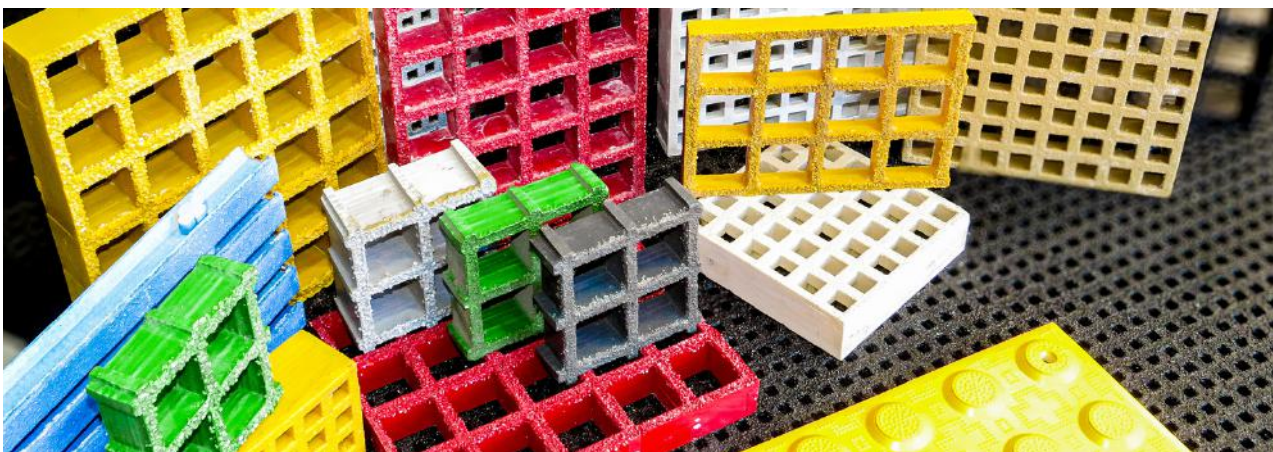

Characteristics of Fiber-Reinforced Polymer (FRP)

For designers and engineers FRP offers a number of advantages that can provide dynamic solutions as well as long term benefits:

Light weight

- 
- Reducing transportation costs and potential occupational health and safety hazards for workers.

Non-conductive

- 
- Reducing risks of electrocution and making this a versatile use product.

Corrosion resistance

- 
- Because FRP materials are not susceptible to corrosion, FRP products offer a great alternative to conventional materials for this major maintenance issue. This benefit is most important in cold climates with snow or coastal areas with salt water. FRP materials have demonstrated excellent durability in corrosive chemical environments for 50 years without degradation.

Quick installation time

- 
- Fabricating customised FRP in a factory and shipping them to your site offers several advantages over many other alternative products. This includes quality can be closely monitored in a controlled environment; the potential for weather delays can be greatly reduced; and most significantly, project down-time can be substantially reduced. Once a superstructure is prepared, prefabricated FRP can be installed quickly, compared to other labor-intensive processes.

High strength

- 
- FRP products provide ultimate strength with very high safety factors. Since FRP material is not as stiff as other competitive construction materials; stiffness performance requirements drive the design of many of our FRP products. Deflection criteria has become one of the most important performances checks we utilize. In addition, static tests of FRP products have clearly demonstrated that FRP greatly exceeds specified performance requirements and provides competitively high safety factors – making it a strong performance competitor to other traditional structural materials.

Lower life cycle costs

- 
- Corrosion resistance results in very low maintenance of FRP products, which translates to lower future maintenance costs. It also means that FRP products will last longer than traditional materials. These add up to lower life cycle costs for FRP.

Temperature and Harsh Environment Resistance

- 
- Compared with steel, timber or other construction materials, FRP is the most economical and efficient solution for harsh industrial and demanding structural construction. FRP also able to withstand severe weather conditions of Australia.

Sustainability Initiatives

Sustainability is a core value at Grating FRP Australia, and we are committed to minimizing our environmental footprint while maximizing the positive impact of our operations.



Eco-Friendly Materials:

We prioritize the use of environmentally friendly FRP products, ensuring our products are long lasting, don't require replacements and will see less wastage in development of niche structures.



Energy Efficiency:

We continually strive to improve the energy efficiency of our operations by investing in energy-efficient equipment and technologies, optimizing production processes, and implementing energy conservation measures throughout our facilities. By reducing energy consumption, we lower our carbon emissions and contribute to a more sustainable future.



Waste Reduction and Recycling:

We are committed to minimizing waste generation and maximizing recycling across all aspects of our operations. We implement waste reduction strategies, such as material optimization and process improvements, to minimize waste generation. Additionally, we actively recycle waste materials, including FRP offcuts and production scrap, when possible, to divert them from landfills and promote a circular economy.



Water Conservation:

We implement water conservation measures to minimize water usage in our manufacturing processes and facility operations. By optimizing water usage and implementing water-saving technologies, we reduce our impact on local water resources and contribute to water sustainability efforts.



Lifecycle Assessment:

We conduct lifecycle assessments of our products to evaluate their environmental impacts from raw material extraction to end-of-life disposal. This holistic approach enables us to identify opportunities for improvement and optimize the environmental performance of our products throughout their lifecycle.



Certifications and Standards:

We adhere to recognized sustainability certifications and standards, such as ISO 14001 (Environmental Management Systems) and LEED (Leadership in Energy and Environmental Design), to demonstrate our commitment to sustainability and provide assurance to our customers and stakeholders.

By embracing these sustainability initiatives, Grating FRP Australia is dedicated to reducing our environmental impact, conserving natural resources, and promoting a more sustainable and resilient future for generations to come.

Industries We Work With

Architectural:

Our expertise encompasses custom-designed FRP panels, cladding systems, and decorative elements that offer a unique blend of aesthetics and functionality. From sleek façade panels to intricate interior finishes, our lightweight FRP materials enable architects to realize their vision while meeting performance requirements.

Local & State Government:

With a large array of applications such as enhancing outdoor experiences with durable and customizable products. Our portfolio includes a range of FRP materials tailored for infrastructure such as trails, bridges, outdoor seating, boardwalks, and more.

Food & Beverage:

From durable processing equipment enclosures to corrosion-resistant structural components and spill management, our lightweight FRP materials offer reliability and longevity in food and beverage facilities.

Mining & Minerals:

Our expertise lies in delivering custom-designed FRP structural access components, spill systems, and equipment enclosures engineered to withstand the rigors of mining operations.

Oil & Gas:

We cover a broad spectrum of services and products to meet structural profiling requirements, access engineering and support from start to finish with our specialized grating systems.

Civil Marine:

Our product range includes corrosion-resistant FRP piles, docks, bridges, and seawalls designed to withstand the harsh marine environment while ensuring long-term durability and structural integrity. With our expertise in custom design and engineering, we deliver solutions optimized for coastal protection, port facilities, marinas, and waterfront developments.

Utilities & Rail:

We provide customized engineering support for rail projects, offering lightweight, durable FRP materials for bridges, platforms, and other infrastructure, cable management systems, and equipment enclosures.

Water & Waste:

Our expertise lies in delivering custom-designed FRP infrastructure, such as treatment systems, durable access covers, developing robust wastewater treatment enclosures, corrosion-resistant piping supports and structural components – all engineered to withstand harsh environmental conditions while ensuring the integrity of water and waste infrastructure.

Recreational:

Our range of lightweight, corrosion-resistant FRP materials is designed to withstand the demands of outdoor adventures, ensuring durability and reliability in marine and off-road environments. Whether it's manufacturing custom FRP boat components, robust vehicle accessories, or hobbyist equipment, we prioritize quality craftsmanship and innovative design.

Examples of how FRP can be used:

Environment	Option of Application
Wastewater Plant	Cover of the trench, walkways, drains, water channel, ventilation valve, stair treads, and flooring.
Chemical Plant	Stair treads, platforms, handrail systems, concrete pool covers, raised flooring, and filter plates.
Oil Industry	Platforms above sea.
Textile Plant	Replacement of metal grating and wooden platforms. Flooring around bleaching and dyeing areas. Flooring around pumps and valves.
Power Plant	Non-conductive and anti-static areas, trench and pit covers, stairways and platforms.
Metal Finishing	Acid washing areas. Replacing wooden floors that surround machines, walkway, raised flooring.
Seafood Processing	Oily surface contaminated area, processing areas.
Transportation	Ships, platforms and contaminated area, stair treads and stairways.
Beverage Plant	Stair treads, replacing stainless steel floor grating.
Pulp & Paper Factory	Stair treads and platform, walkways, wet area access.
Electronic Industry	Access pit covers, acid pickling plants and electronic resistance application options (non-conductive grating).
Meat Processing Factory	Drains, trench covers, platforms, ramps, and holding yards.
Architecture & Landscape	Shop fronts, landscaping, screening, cladding and paneling, wall and roof.

FRP Grating Grit Options & Surface Finish



Grit Size Key:

1. Heavy Duty - 3.8mm
2. Heavy Duty - 3.2mm
3. Medium Duty - 2.8mm
4. Medium Duty - 2.5mm
5. Medium Duty - 2.2mm
6. Medium Duty - 1.5mm
7. Light Duty - 1.2mm
8. Light Duty - 0.8mm
9. Light Duty - 0.6mm
10. Light Duty - 0.3mm

Grating FRP Australia specializes in premium Fiberglass Reinforced Plastic (FRP) grating solutions designed to meet stringent safety and performance standards. Our gratings provide exceptional slip resistance, verified through Australian pendulum testing, ensuring a safe surface in wet and dry conditions. These attributes make our products ideal for industrial and public applications where safety is paramount.

The surface texture of our FRP gratings is engineered for maximum grip and durability. Our products feature a high-spec gritted surface, incorporating quartz, glass bead or aluminum oxide granules. This gritted finish offers superior slip resistance, exceeding safety benchmarks even under heavy foot traffic and exposure to contaminants such as oil, water, or chemicals. The various coarse textures we use are designed to maintain its performance over time, providing a reliable solution for high-traffic areas.

Our gratings are available in multiple textures, including light grit and standard grit for general use and heavy-duty grit for environments requiring enhanced safety - this can be referenced to the Australian Standards Guide AS/NZS 4586. The texture not only ensures slip resistance but also contributes to the longevity of the product, making the grating resilient to wear and harsh conditions. These features are combined with UV stability, ensuring that the surface maintains its effectiveness and appearance in outdoor applications.



Grating Application Examples



Grating Application Examples



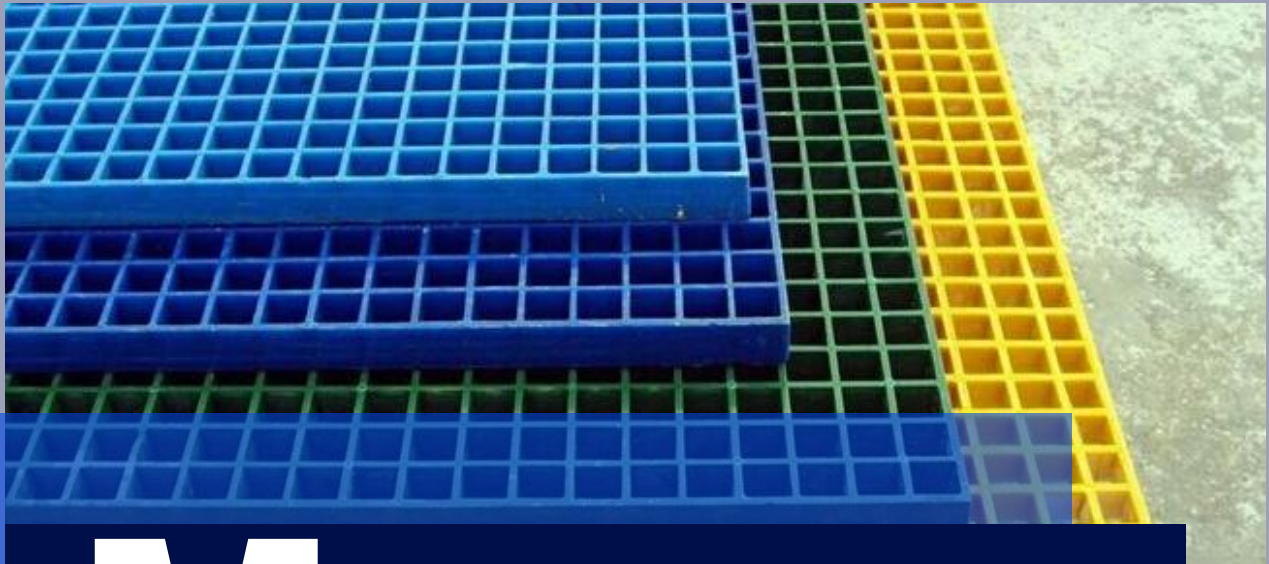

Moulded Grating

Our moulded fibreglass grating is manufactured by interfacing reinforcing fibreglass roving within a polyester resin, thermally cured in the mold. Grating produced using this technique yield a product having 30-35% (by total weight) of fibreglass reinforcement. For fire retardant protection, the resin used are complete with fire retardant additive to obtain class 1 fire spread rating of 25 or less as per ASTM E-84. Uv Inhibitors and antioxidant are included into the products recipe of grating to achieve the best UV protection on the market.

Comparing with other floor materials, FRP moulded grating provides a series of benefits, unmatched impact resistance, while the strength-weight-ratio is only one-fourth of that of steel grating. It is easy to cut and install.

FRP moulded grating has high corrosion resistance. Using different resin achieves different properties of corrosion resistance.

Standard resins being used include Orthophthalic, Polyester resin, Isophthalic Polyester, Vinyl Ester resin. Vinyl Ester grating provides extremely high corrosion resistance.

The surface of FRP moulded grating can be concaved top, flat top, grit top, checker cover, grit cover and smooth cover.

KEY:

- Any product listed that is bold, underlined and highlighted blue is a **COMMONLY STOCKED ITEM.**

FRP Moulded Grating Specifications



38.1mm x 38.1mm Mesh

Unit: mm

Image	Depth	Bar Thickness	Standard Dimension	Weight (kg/m ²)	Open Ratio %
	14	6.0/ 5.0	1524 x 4000 <u>1220 x 3660</u> 1220 x 2440 921 x 3050 <u>610 x 3660</u>	6.1	78
	15	6.0/ 5.0	1524 x 4000 1220 x 3660 1220 x 2440 921 x 3050	7.1	78
	20	6.5/ 5.0	1524 x 4000 1220 x 3660 1220 x 2440 921 x 3050	9.6	68
	25	6.5/ 5.0	<u>998 x 3015</u> <u>998 x 2025</u> 1524 x 4000 <u>1220 x 3660</u> 1220 x 2440 921 x 3050	12.3	68
	30	6.5/ 5.0	1524 x 4000 <u>1220 x 3660</u> 1220 x 2440 921 x 3050	14.6	68
	38	7.0/ 5.0	<u>998 x 2025</u> 1524 x 4000 <u>1220 x 3660</u> 1220 x 2440 921 x 3050	19.5	68
	40	7.0/ 5.0	1524 x 4000 1220 x 3660 1220 x 2440 921 x 3050	20.6	68
	50 (HD)	9.5/ 7.5	<u>1220 x 3660</u> 1220 x 2440 921 x 3050	40.0	56
	60 (HD)	10.5/ 8.5	1220 x 3660 1220 x 2440 921 x 3050	48.0	54
	65 (HD)	11.0/ 9.0	1220 x 3660 1220 x 2440 921 x 3050	52.0	52

KEY:

Any product listed that is bold, underlined and highlighted blue is a **COMMONLY STOCKED ITEM.**

40mm x 40mm Mesh

Unit: mm

Image	Depth	Bar Thickness	Standard Dimension	Weight (kg/m ²)	Open Ratio %
	25	7.0/ 5.0	1007 x 3007 1007 x 4007 1247 x 3687 1527 x 4047	12.3	67
	30	7.0/ 5.0	1007 x 3007 1007 x 4007 1247 x 3687 1527 x 4047	14.5	67
	40	7.0/ 5.0	1007 x 3007 1007 x 4007 1247 x 3687 1527 x 4047	19.2	67

50.8 x 50.8mm Mesh

Unit: mm

Image	Depth	Bar Thickness	Standard Dimension	Weight (kg/m ²)	Open Ratio %
	13	6.0/ 5.0	1524 x 4000 1220 x 3660 1220 x 2440 921 x 3050	5.8	82
	15	7.0/ 6.0	1524 x 4000 1220 x 3660 1220 x 2440 921 x 3050	6.8	82
	25	7.5/ 6.0	1524 x 4000 1220 x 3660 1220 x 2440 921 x 3050	11.8	78
	38	7.0/ 5.0	1524 x 4000 1220 x 3660 1220 x 2440 921 x 3050	17.8	78
	50	7.5/ 5.0	1524 x 4000 1220 x 3660 1220 x 2440 921 x 3050	21.5	78
	50	8.0/ 6.0	1524 x 4000 1220 x 3660 1220 x 2440 921 x 3050	23.5	78

83 x 83mm Mesh

Unit: mm

Image	Depth	Bar Thickness	Standard Dimension	Weight (kg/m ²)	Open Ratio %
	25	7.0/ 5.0	1007 x 4007	6.1	84
	40	7.0/ 5.0	1007 x 4007	9.6	84

KEY:

Any product listed that is bold, underlined and highlighted blue is a **COMMONLY STOCKED ITEM.**

25 x 100mm Mesh

Unit: mm

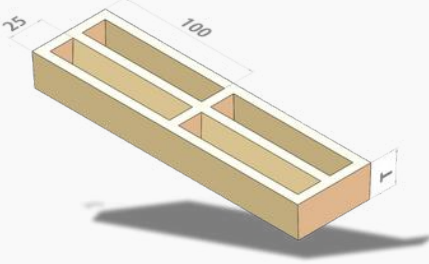
Image	Depth	Bar Thickness	Standard Dimension	Weight (kg/m ²)	Open Ratio %
	25	7.0/ 5.0	1007 x 4007 1007 x 3007	13.0	67
	30	7.0/ 5.0	1007 x 4007 1007 x 3007	15.6	67

25.4 x 101.6mm Mesh

Unit: mm

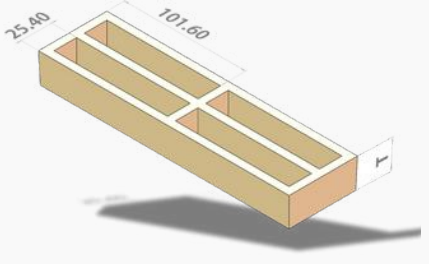
Image	Depth	Bar Thickness	Standard Dimension	Weight (kg/m ²)	Open Ratio %
	25	6.5/ 5.0	1220 x 3660 921 x 3050	13.0	67
	25 HD	9.5/ 8.0	1220 x 3660 921 x 3050	15.6	67

38.1 x 101.6mm Mesh

Unit: mm

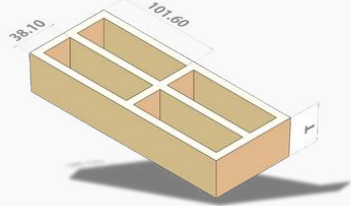
Image	Depth	Bar Thickness	Standard Dimension	Weight (kg/m ²)	Open Ratio %
	38	8.0/ 6.0	1220 x 3660 921 x 3050	13.0	65

25.4 x 152.4mm Mesh

Unit: mm

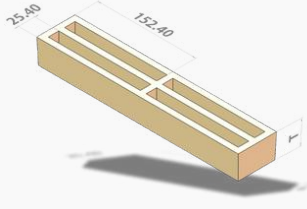
Image	Depth	Bar Thickness	Standard Dimension	Weight (kg/m ²)	Open Ratio %
	38	9.0/ 6.5	1220 x 3660 921 x 3050	22.5	63

38.1 x 152.4mm Mesh

Unit: mm

Image	Depth	Bar Thickness	Standard Dimension	Weight (kg/m ²)	Open Ratio %
	38	8.0/ 6.0	1220 x 3660 921 x 3050	15.9	67

25.4 x 50.8mm Mesh

Unit: mm

Image	Depth	Bar Thickness	Standard Dimension	Weight (kg/m ²)	Open Ratio %
	38	11.0/ 9.0	1220 x 1830	30.7	49
	50	12.0/ 9.0	1220 x 1830 1220 x 3660	41.8	48

60 x 100mm Mesh

Unit: mm

Image	Depth	Bar Thickness	Standard Dimension	Weight (kg/m ²)	Open Ratio %
	28	6.5/ 5.0	1500 x 4000 1500 x 2000	7.2	78

60 x 220mm Mesh

Unit: mm

Image	Depth	Bar Thickness	Standard Dimension	Weight (kg/m ²)	Open Ratio %
	40	6.3/ 5.0	1788 x 4476 1788 x 2238	8.8	67

25.4 x 101.6mm Mesh (Disability Friendly)

Unit: mm

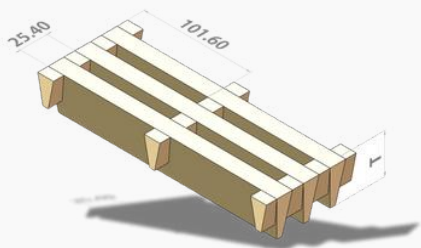
Image	Depth	Bar Thickness	Standard Dimension	Weight (kg/m ²)	Open Ratio %
	38	15.0/ 5.0	1220 x 3660	21.0	62

38.1 x 101.6mm Mesh

Unit: mm

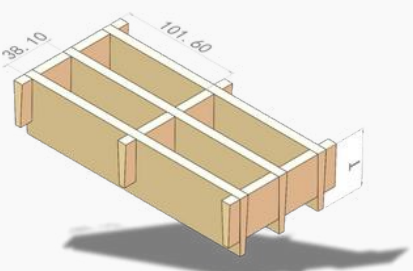
Image	Depth	Bar Thickness	Standard Dimension	Weight (kg/m ²)	Open Ratio %
	50	8.0/ 5.0	1220 x 3660	15.3	68

FRP Moulded Grating Specifications Mini Mesh

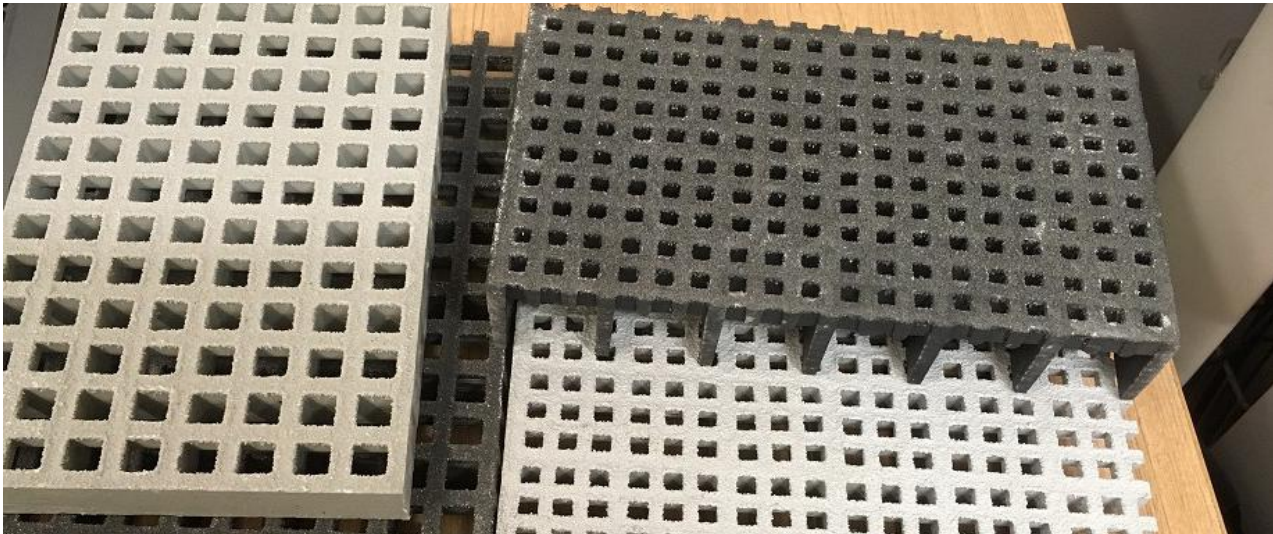

19.05 x 19.05 / 38.1 x 38.1mm Mini Mesh (Disability Friendly)

Unit: mm

Image	Depth	Bar Thickness	Standard Dimension	Weight (kg/m ²)	Open Ratio %
	25	6.5/ 5.0	1524 x 4000 1220 x 3660 1220x2440 921 x 3050	16.8	30
	30	6.5/ 5.0	1524 x 4000 1220 x 3660 1220x2440 921 x 3050	18.5	30
	38	6.5/ 5.0	1524 x 4000 1220 x 3660 1220x2440 921 x 3050	23.5	30

25.4 x 25.4 / 50.8 x 50.8mm Mini Mesh

Unit: mm

Image	Depth	Bar Thickness	Standard Dimension	Weight (kg/m ²)	Open Ratio %
	15	6.5/ 5.0	1220 x 3660 1220 x 2440 921 x 3050	7.5	55
	50	8.0/ 6.0	1524 x 3660 1220 x 3660 1220 x 2440 921 x 3050	28.5	55

KEY:

Any product listed that is bold, underlined and highlighted blue is a **COMMONLY STOCKED ITEM.**

20 x 20mm / 40 x 40 Mini Mesh (Disability Friendly)

Unit: mm

Image	Depth	Bar Thickness	Standard Dimension	Weight (kg/m ²)	Open Ratio %
	14	7.0/ 5.0	1247 x 4047 1247 x 3687 1007 x 4007 1007 x 3007	10.5	42
	22	7.0/ 5.0	1527 x 4047 1247 x 3687 1007 x 4007 1007 x 3007	14.5	42
	30	7.0/ 5.0	1527 x 4047 1247 x 3687 1007 x 4007 1007 x 3007	18.0	42
	40	7.0/ 5.0	1527 x 4047 1247 x 3687 1007 x 4007 1007 x 3007	23.5	42
	60	7.0/ 5.0	1007 x 2007 1007 x 3007	38.5	42

26 x 26/ 52 x 52mm Mini Mesh

Unit: mm

Image	Depth	Bar Thickness	Standard Dimension	Weight (kg/m ²)	Open Ratio %
	30	6.5/ 5.0	1532 x 4050	15.5	60
	38	6.5/ 5.0	1220 x 3660 1205 x 4011	19.5	60

13 x 13 / 40 x 40mm Mini Mesh (Disability Friendly)

Unit: mm

Image	Depth	Bar Thickness	Standard Dimension	Weight (kg/m ²)	Open Ratio %
	22	7.0/ 5.0	1247 x 3685 1527 x 4047 1247 x 4047 1007 x 4007 1007 x 3007	15.0	30
	30	7.0/ 5.0	1527 x 4047 1247 x 4047 1007 x 4007 1007 x 3007	19.0	30
	40	7.0/ 5.0	1527 x 4047 1247 x 4047 1007 x 4007 1007 x 3007	25.0	30

KEY:

Any product listed that is bold, underlined and highlighted blue is a **COMMONLY STOCKED ITEM.**

Unique Types of Moulded Grating

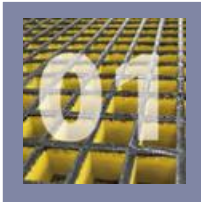

Conductive Grating

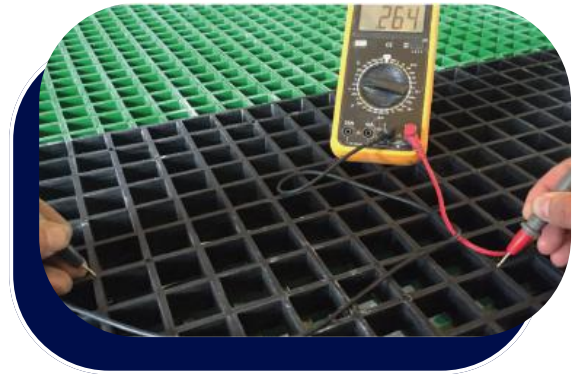

Conductive Grating is primarily used in the high-tech electronic industries, munitions, arsenal manufacturing plants, and other sparking sensitive environments where sophisticated equipment may be damaged due to static electricity. The electric resistance of our conductive grating is 1×10^5 ohms to 5×10^5 ohms.

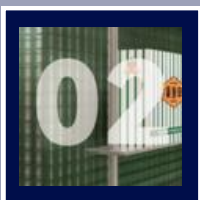

Transparent Grating



Transparent Grating is produced by pure resin or with low content of colour paste. With UV inside, this type of grating can keep its colour stable for a long time. Due to the high content of the resin, has even better chemical resistance than normal grating with colours. Transparent gratings are used as walkway, wall decoration and fencing. Also, many applications where clients ask for genius chemical resistance and will choose this type of pure resin grating.



Pultruded Grating

Pultruded FRP Grating is one of the highest strength-to-weight ratios of any material, Grating FRP Australia Pultruded Structural fiberglass grating is strong and durable, ready for years of dependable use. Unlike steel, FRP Grating has memory, springing back to its original shape when deflected. Even major impacts inflict little damage without failure.

Manufactured using a pultrusion process, our grating itself is assembled by pultruded I-Bar or T-Bars, pre-drilled with cross bars and glued with a supreme epoxy resin. With 60-65% fiberglass content, pultruded gratings performs with outstanding properties and are excellent for large span applications.

Pultruded Grating Specifications

Type	Thickness	Bearing Bar Centre	Cross Bar Center (mm)	Open Area %	Weight kg/m ²
T-1210	25	43.4	152.4	12	14.5
T-1810	25	50.8	152.4	18	13.8
T-2510	25	50.8	152.4	25	13.6
T-3310	25	61.0	152.4	33	11.2
T-3810	25	61.0	152.4	38	10.2
T-1215	38	43.3	152.4	12	19.6
T-2515	38	50.8	152.4	25	16.7
T-3815	38	61.0	152.4	38	14.2
I-4010	25	25.4	152.4	40	17.1
I-50125	25	30.0	152.4	50	14.2
I-6010	25	38.1	152.4	60	11.2
I-40125	30	25.4	152.4	40	19.8
I-50125	30	30.5	152.4	50	17.4
I-60125	30	37.1	152.4	60	13.5
I-4015	38	38.1	152.4	40	22.0
I-5015	38	50.8	152.4	50	19.1
I-6015	38	30.2	152.4	60	16.1
T-3320	50	30.2	152.4	33	20.3
T-5020	50	30.2	152.4	50	15.7
HI-4710	25	30.2	152.4	47	27.6
HI-4715	38	30.2	152.4	47	40.0
HI-4720	50	30.2	152.4	47	54.5
HI-4725	64	30.2	152.4	47	61.6
HI-4730	76	30.2	152.4	47	73.6
HI-5810	25	38.1	152.4	58	21.0
HI-5815	38	38.1	152.4	58	31.8
HI-5820	50	38.1	152.4	58	42.5
HI-5825	64	38.1	152.4	58	48.9
HI-5830	76	38.1	152.4	58	58.6
HL-4020	50	25.4	152.4	40	70.4
HL-5020	50	30.0	152.4	50	52.2
HL-6020	50	38.1	152.4	60	43.5
SI-7310	25	30.2	152.4	73	13.2
SI-7315	38	30.2	152.4	73	18.6
SI-8310	25	47.6	152.4	83	8.5
SI-8315	38	47.6	152.4	83	12.0

Pultruded Grating - Pedestrian Specifications

Our pedestrian pultruded grating is designed for pedestrian traffic. The gratings are assembled by wide 'T' bars. They are designed ideally for the application of access areas and walkways. Some of our pedestrian gratings can comply with ADA (Americans with Disabilities Act of 1990) and DDA (Disability Discrimination Act in UK).

Type	Thickness	Bearing Bar Centre	Cross Bar Center (mm)	Open Area %	Weight kg/m ²
T-1210	25	43.4	152.4	12	14.5
T-1810	25	50.8	152.4	18	13.8
T-2510	25	50.8	152.4	25	13.6
T-3310	25	61.0	152.4	33	11.2
T-3810	25	61.0	152.4	38	10.2
T-1215	38	43.3	152.4	12	19.6
T-2515	38	50.8	152.4	25	16.7
T-3815	38	61.0	152.4	38	14.2

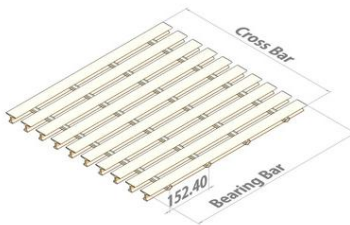
	T-1210 - 25mm Height 12% Open Area			ADA Compliant
	No. of bars per 1 meter width	23	Opening C	5.4mm
	Bearing bar width T/B	38mm / 15mm	Weight	17.9kg/m ²
	Bearing bar center. A	43.3mm	Max size (w x l)	1524 x 6100mm

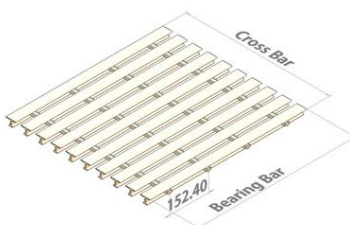
	T-1810 - 25mm Height 18% Open Area			ADA Compliant
	No. of bars per 1 meter width	19	Opening C	9.5mm
	Bearing bar width T/B	41.3mm/ 15mm	Weight	13.8kg/m ²
	Bearing bar center. A	50.8mm	Max size (w x l)	1524 x 6100mm

	T-2510 - 25mm Height 25% Open Area			ADA Compliant
	No. of bars per 1 meter width	19	Opening C	12.7mm
	Bearing bar width T/B	38mm/ 15mm	Weight	13.6kg/m ²
	Bearing bar center. A	50.8mm	Max size (w x l)	1524 x 6100mm

	T-3310 - 25mm Height 33% Open Area			
	No. of bars per 1 meter width	16	Opening C	19.7mm
	Bearing bar width T/B	41.3/ 15mm	Weight	11.2kg/m ²
	Bearing bar center. A	61mm	Max size (w x l)	1524 x 6100mm

	T-3810 - 25mm Height 38% Open Area			
	No. of bars per 1 meter width	16	Opening C	23mm
	Bearing bar width T/B	38mm/ 15mm	Weight	11.6kg/m ²
	Bearing bar center. A	61mm	Max size (w x l)	1524 x 6100mm

	T-1215 - 38mm Height 12% Open Area			ADA Compliant
	No. of bars per 1 meter width	23	Opening C	5.4mm
	Bearing bar width T/B	38mm/15mm	Weight	19.6kg/m ²
	Bearing bar center. A	43.3mm	Max size (w x l)	1524 x 6100mm

	T-2515 - 38mm Height 25% Open Area			ADA Compliant
	No. of bars per 1 meter width	19	Opening C	12.7mm
	Bearing bar width T/B	38mm/ 15mm	Weight	16.7kg/m ²
	Bearing bar center. A	50.8mm	Max size (w x l)	1524 x 6100mm

	T-3815 - 38mm Height 38% Open Area			
	No. of bars per 1 meter width	16	Opening C	23mm
	Bearing bar width T/B	38mm/15mm	Weight	14.2kg/m ²
	Bearing bar center. A	61mm	Max size (w x l)	1524 x 6100mm

Industrial Series Grating

Industrial series grating is designed for wide application of various industrial area where requests promote high strength and corrosion resistance. Industrial gratings are ideal selections for the applications that request for wider span with small deflections. Several types of our industrial series gratings can comply with ADA (Americans with Disability Act of 1990) and DDA (Disability Discrimination Act in the UK).

Type	Thickness	Bearing Bar Centre	Cross Bar Center (mm)	Open Area %	Weight kg/m ²
I-4010	25	25.4	152.4	40	17.1
I-5010	25	30.0	152.4	50	14.2
I-6010	25	38.1	152.4	60	11.2
I-40125	30	25.4	152.4	40	19.8
I-50125	30	30.5	152.4	50	17.4
I-60125	30	37.1	152.4	60	13.5
I-4015	38	25.4	152.4	40	22.0
I-5015	38	30.5	152.4	50	19.1
I-6015	38	37.1	152.4	60	16.1
T-3320	50	38.1	152.4	33	20.3
T-5020	50	50.8	152.4	50	15.7

	I-4010 - 25mm Height 40% Open Area			ADA Compliant
	No. of bars per 1 meter width	40	Opening C	10mm
	Bearing bar width T/B	15mm/ 15mm	Weight	17.8kg/m ²
	Bearing bar center. A	25mm	Max size (w x l)	1524 x 6100mm

	I-5010 - 25mm Height 50% Open Area			
	No. of bars per 1 meter width	33	Opening C	15mm
	Bearing bar width T/B	15mm/ 15mm	Weight	15.1kg/m ²
	Bearing bar center. A	30mm	Max size (w x l)	1524 x 6100m ²

	T-6010 - 25mm Height 60% Open Area			
	No. of bars per 1 meter width	26	Opening C	23mm
	Bearing bar width T/B	15mm / 15mm	Weight	12.2kg/m ²
	Bearing bar center. A	38mm	Max size (w x l)	1524 x 6100mm

	T-40125 - 32mm Height 40% Open Area			ADA Compliant
	No. of bars per 1 meter width	40	Opening C	10mm
	Bearing bar width T/B	15mm / 15mm	Weight	19.8kg/m ²
	Bearing bar center. A	25mm	Max size (w x l)	1524 x 6100mm

	I-50125 - 32mm Height 50% Open Area			
	No. of bars per 1 meter width	33	Opening C	23mm
	Bearing bar width T/B	15mm / 15mm	Weight	13.5kg/m ²
	Bearing bar center. A	38mm	Max size (w x l)	1524 x 3100mm

	I-60125 - 32mm Height 60% Open Area			
	No. of bars per 1 meter width	26	Opening C	23mm
	Bearing bar width T/B	15mm / 15mm	Weight	13.5kg/m ²
	Bearing bar center. A	38mm	Max size (w x l)	1524 x 6100mm

	I-4015 - 38mm Height 40% Open Area			ADA Compliant
	No. of bars per 1 meter width	40	Opening C	10mm
	Bearing bar width T/B	15mm / 15mm	Weight	22kg/m ²
	Bearing bar center. A	25mm	Max size (w x l)	1524 x 6100mm

	I-5015 - 38mm Height 40% Open Area			
	No. of bars per 1 meter width	33	Opening C	10mm
	Bearing bar width T/B	15mm / 15mm	Weight	22kg/m ²
	Bearing bar center. A	30mm	Max size (w x l)	1524 x 6100mm

	I-5015 - 38mm Height 50% Open Area			
	No. of bars per 1 meter width	26	Opening C	23mm
	Bearing bar width T/B	15mm/ 15mm	Weight	16.2kg/m ²
	Bearing bar center. A	38mm	Max size (w x l)	1524 x 6100mm

	T-3320 - 50mm Height 33% Open Area			ADA Compliant
	No. of bars per 1 meter width	26	Opening C	12.7mm
	Bearing bar width T/B	25.4mm/ 15mm	Weight	21.7kg/m ²
	Bearing bar center. A	38mm	Max size (w x l)	1524 x 6100mm

	T-5020 - 50mm Height 50% Open Area			
	No. of bars per 1 meter width	20	Opening C	25.4mm
	Bearing bar width T/B	25.4mm/ 15mm	Weight	17.2kg/m ²
	Bearing bar center. A	50.85mm	Max size (w x l)	1524 x 6100mm

High Load Capacity Series Grating

Our high load capacity pultruded grating is engineered for forklift, tractor, trailer or high load with large spans where the traditional pultruded grating is not able to support. We have a vast variation of our pedestrian series gratings comply with ADA (Americans with Disabilities Act of 1990) and DDA (Disability Discrimination Act in the UK).

Type	Thickness	Bearing Bar Centre	Cross Bar Center (mm)	Open Area %	Weight kg/m ²
HI-4710	25	30.2	152.40	47	27.6
HI-4715	38	30.2	152.40	47	40.0
HI-4720	50	30.2	152.40	47	54.5
HI-4725	64	30.2	152.40	47	61.6
HI-4730	76	30.2	152.40	47	73.6
HI-5810	25	38.1	152.40	58	21.0
HI-5815	38	38.1	152.40	58	31.8
HI-5820	50	38.1	152.40	58	42.5
HI-5825	64	38.1	152.40	58	48.9
HI-5830	76	38.1	152.40	58	58.6
HL-4020	50	5.4	152.40	40	70.4
HL-5020	50	30.0	152.40	50	52.2
HL-6020	50	38.1	152.40	60	43.5

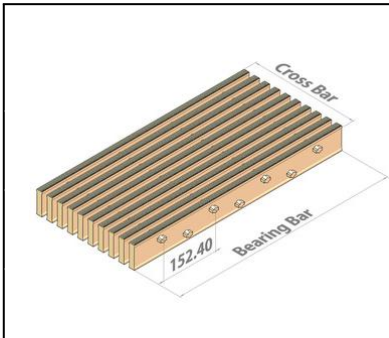
				
HI-4710 - 25mm Height 47% Open Area				
No. of bars per 1 meter width	33	Opening C	14.3mm	
Bearing bar width T/B	15.9/ 14.4/ 15.9mm	Weight	27.6kg/m ²	
Bearing bar center. A	30.2mm	Max size (w x l)	1524 x 6100mm	

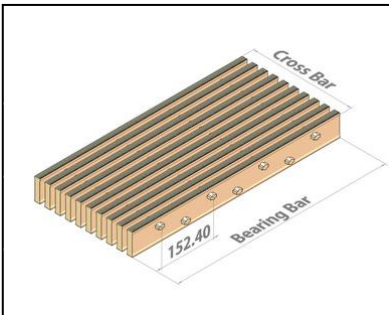
				
HI-4715 - 38mm Height 47% Open Area				
No. of bars per 1 meter width	33	Opening C	14.3mm	
Bearing bar width T/B	15.9/ 14.4/ 15.9mm	Weight	27.6kg/m ²	
Bearing bar center. A	30.2mm	Max size (w x l)	1524 x 6100mm	

	HI-4715 - 328mm Height 47% Open Area			
	No. of bars per 1 meter width	33	Opening C	14.3mm
	Bearing bar width T/B	15.9/ 14.4/ 15.9mm	Weight	40kg/m ²
	Bearing bar center. A	30.2mm	Max size (w x l)	1524 x 6100mm

	HI-4720 - 50mm Height 47% Open Area			
	No. of bars per 1 meter width	33	Opening C	14.3mm
	Bearing bar width T/B	15.9/ 14.4/ 15.9mm	Weight	54.5kg/m ²
	Bearing bar center. A	30.2mm	Max size (w x l)	1524 x 6100mm

	HI-4725 - 64mm Height 47% Open Area			
	No. of bars per 1 meter width	33	Opening C	14.3mm
	Bearing bar width T/B	15.9/ 14.4/ 15.9mm	Weight	61.6kg/m ²
	Bearing bar center. A	30.2mm	Max size (w x l)	1524 x 6100mm

	HI-4730 - 76mm Height 47% Open Area			
	No. of bars per 1 meter width	33	Opening C	14.3mm
	Bearing bar width T/B	15.9/ 14.4/ 15.9mm	Weight	61.6kg/m ²
	Bearing bar center. A	30.2mm	Max size (w x l)	1524 x 6100mm

	HI-5810 - 25mm Height 58% Open Area			
	No. of bars per 1 meter width	26	Opening C	22.2mm
	Bearing bar width T/B	15.9/ 14.4/ 15.9mm	Weight	21.0kg/m ²
	Bearing bar center. A	38.1mm	Max size (w x l)	1524 x 6100mm

	HI-5815 - 38mm Height 58% Open Area			
	No. of bars per 1 meter width	26	Opening C	22.2mm
	Bearing bar width T/B	15.9/ 14.4/ 15.9mm	Weight	31.8kg/m ²
	Bearing bar center. A	38.1mm	Max size (w x l)	1524 x 6100mm

	HI-5820 - 50mm Height 58% Open Area			
	No. of bars per 1 meter width	26	Opening C	22.2mm
	Bearing bar width T/B	15.9/ 14.4/ 15.9mm	Weight	42.5kg/m ²
	Bearing bar center. A	38.1mm	Max size (w x l)	1524 x 6100mm

	HI-5825 - 64mm Height 58% Open Area			
	No. of bars per 1 meter width	26	Opening C	22.2mm
	Bearing bar width T/B	15.9/ 14.4/ 15.9mm	Weight	48.9kg/m ²
	Bearing bar center. A	38.1mm	Max size (w x l)	1524 x 6100mm





	HI-5830 - 76mm Height 58% Open Area			
	No. of bars per 1 meter width	26	Opening C	22.2mm
	Bearing bar width T/B	15.9/ 14.4/ 15.9mm	Weight	58.6kg/m ²
Bearing bar center. A	38.1mm	Max size (w x l)	1524 x 6100mm	

	HL-4020 - 50mm Height 40% Open Area			ADA Compliant
	No. of bars per 1 meter width	40	Opening C	10mm
	Bearing bar width T/B	15mm/ 15mm	Weight	70.4kg/m ²
Bearing bar center. A	25mm	Max size (w x l)	1524 x 6100mm	

	HL-5020 - 50mm Height 50% Open Area			
	No. of bars per 1 meter width	33	Opening C	15mm
	Bearing bar width T/B	15mm/ 15mm	Weight	52.2kg/m ²
Bearing bar center. A	25mm	Max size (w x l)	1524 x 6100mm	

	HL-5020 - 50mm Height 50% Open Area			
	No. of bars per 1 meter width	26	Opening C	23mm
	Bearing bar width T/B	15mm/ 15mm	Weight	43.5kg/m ²
Bearing bar center. A	25mm	Max size (w x l)	1524 x 6100mm	

Maximum Traffic Conditions

Design Load						
		AASHTO standard truck 14,285kg Dual Wheels	Automobile traffic 2,270kg vehicle 681kg load 55% drive axle load	5 tonne capacity forklift 6,583kg vehicle 11,075kg total load 85% drive axle load	3 tonne capacity forklift 4,449kg vehicle 7,173kg total load 85% drive axle load	1 tonne capacity forklift 1,907kg vehicle 2,815kg total load 85% drive axle load
Wheel Load (kg) (1/2 Axle Load + 30% Impact)		9,443	1,008	6,120	3,963	1,555
Load Distribution	Parallel to Axle	508 + 60mm	203 + 60mm	279 + 60mm	178 + 60mm	102 + 60mm
	Perpendicular to Axle	203mm	203mm	279mm	178mm	102mm
Allow Span	HI-4710	229mm	406mm	203mm	203mm	229mm
	HI-4715	356mm	711mm	330mm	330mm	406mm
	HI-4720	635mm	1194mm	533mm	533mm	838mm
	HI-4725	737mm	1448mm	635mm	635mm	991mm
	HI-4730	965mm	1778mm	813mm	813mm	1295mm
Load Distribution	Parallel to Axle	508 + 76mm	203 + 76mm	279 + 76mm	178 + 76mm	102 + 76mmmm
	Perpendicular to Axle	203mm	203mm	279mm	178mm	102mm
Allow Span	HI-5810	203mm	356mm	203mm	178mm	203mm
	HI-5815	305mm	584mm	279mm	254mm	330mm
	HI-5820	533mm	991mm	457mm	457mm	686mm
	HI-5825	584mm	1194mm	533mm	508mm	787mm
	HI-5830	787mm	1473mm	686mm	660mm	1067mm

Notes:

- 1) Load is carried by the grating load bars immediately under wheel + two additional load bars, one each side of each wheel.
- 2) Allowable span is based on a 6.4mm deflection and a factor of safety of 3.0. Other criteria may be required by certain construction codes. Check code requirements to determine design criteria.
- 3) Allowable Span is strongly dependent on wheel width and vehicle weight/ load capacity.
- 4) Load based on the AASHTO standard truck load as defined in AASHTO LFRD bridge design specifications, 2nd Ed. This doesn't imply that the allowable span meet the deflection requirements of the specifications.

Standard I Bar Series Grating

Our industrial series grating widely used in cooling tower walkways due to it's large open area. The bonded rod crossbars make pultruded SI series gratings suitable for use in pedestrian traffic areas and the 73% and 83% open areas, where a close match to a steel or aluminum profile is desired.

Type	Thickness	Bearing Bar Centre	Cross Bar Center (mm)	Open Area %	Weight kg/m ²
SI-7310	25	30.2	152.40	73	13.2
SI-7315	38	30.2	152.40	73	18.6
SI-8310	25	47.6	152.40	73	8.5
SI-8315	38	47.6	152.40	73	12.0

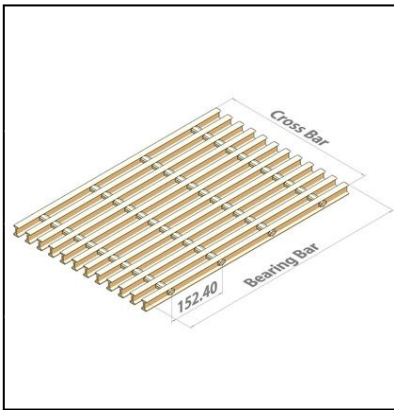

SI-7310 - 25mm Height 73% Open Area			
No. of bars per 1 meter width	33	Opening C	22.2mm
Bearing bar width T/B	7.9mm/ 7.9mm	Weight	13.2kg/m2
Bearing bar center. A	30.2mm	Max size (w x l)	1524 x 6100mm

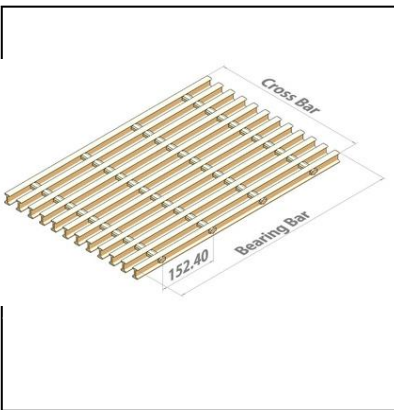

SI-7315 - 38mm Height 73% Open Area			
No. of bars per 1 meter width	33	Opening C	22.2mm
Bearing bar width T/B	7.9mm/ 7.9mm	Weight	18.6kg/m2
Bearing bar center. A	30.2mm	Max size (w x l)	1524 x 6100mm

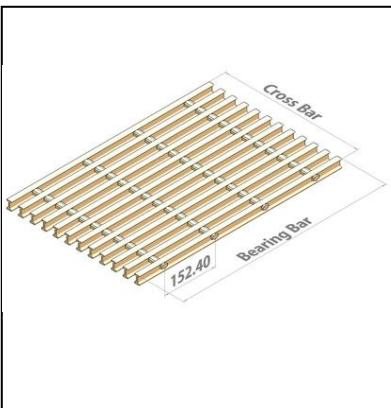

SI-8310 - 25mm Height 83% Open Area			
No. of bars per 1 meter width	21	Opening C	39.6mm
Bearing bar width T/B	7.9mm/ 7.9mm	Weight	8.5kg/m2
Bearing bar center. A	47.6mm	Max size (w x l)	1524 x 6100mm

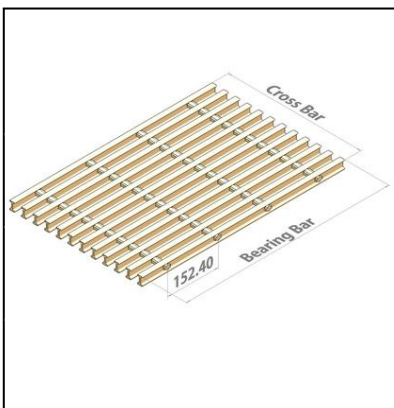

SI-8315 - 38mm Height 83% Open Area			
No. of bars per 1 meter width	21	Opening C	39.6mm
Bearing bar width T/B	7.9mm/ 7.9mm	Weight	12.0kg/m2
Bearing bar center. A	47.6mm	Max size (w x l)	1524 x 6100mm



S

tructural Profile

Our pultruded structural profiles are manufactured by pultrusion process with 60-65% fibreglass content and finished with a resin rich surface. Structural shapes are ideally designed for application where request for low maintenance, high strength, fire retardant and corrosion resistance are required. Our high-performance shapes are widely used in many fields, including offshore/ marine, water treatment, chemical plants, oil & gas industries and so on.

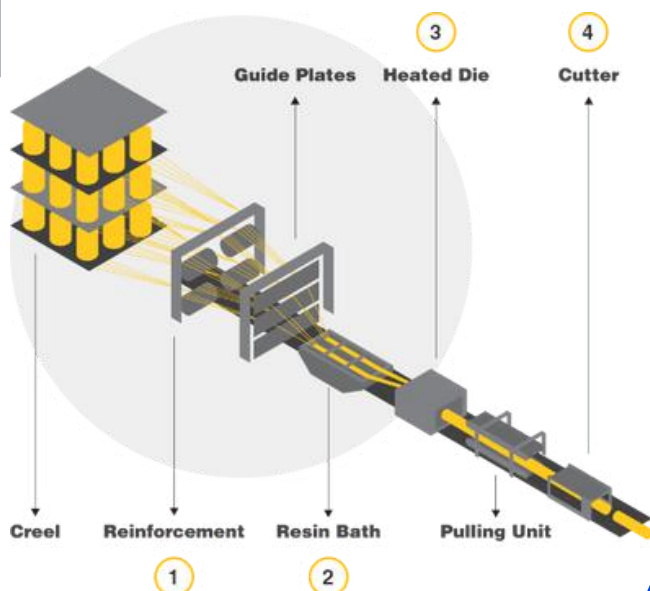

C Chanel	Dimension (mm) A x B x T	Weight (kg/m)
	50 x 14 x 3.2	0.44
	76 x 22 x 6.4	1.31
	76 x 38 x 6.4	1.70
	102 x 29 x 4.8	1.42
	102 x 44 x 4.8	1.65
	102 x 44 x 6.4	2.10
	120 x 25 x 5.0	1.52
	120 x 30 x 5.0	1.62
	120 x 40 x 5.0	1.81
	152 x 42 x 4.8	2.03
	152 x 42 x 6.4	2.72
	152 x 42 x 9.5	3.95
	203 x 56 x 6.4	3.68
	203 x 56 x 9.5	5.34
	210 x 55 x 5.0	2.95
	210 x 80 x 5.0	3.42
	210 x 85 x 5.0	3.52
	254 x 70 x 12.7	8.90
	260 x 76.2 x 12.7	9.42
	290 x 70 x 12.7	9.60
305 x 76 x 12.7	9.60	

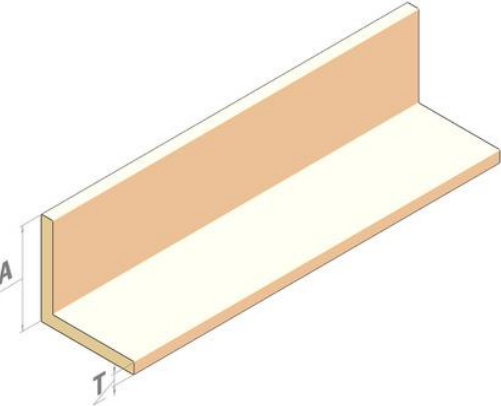
Equal Angle	Dimension (mm) A x T	Weight (kg/m)
	25 x 3.2	0.33
	25 x 6.4	0.56
	30 x 5.0	0.57
	38 x 3.2	0.46
	38 x 4.8	0.65
	38 x 6.4	0.85
	50 x 3.2	0.61
	50 x 4.8	0.86
	50 x 6.4	1.14
	76 x 6.4	1.77
	76 x 9.5	2.57
	76 x 12.7	3.40
	101 x 6.4	2.50
	101 x 9.5	3.48
	101 x 12.7	4.57
	152 x 6.4	3.62
	152 x 9.5	5.42
	152 x 12.7	7.01

Square Tube	Dimension (mm) A x T	Weight (kg/m)
	25 x 3.2	0.53
	25 x 6.4	0.90
	32 x 3.2	0.70
	32 x 6.4	1.24
	38 x 3.2	0.85
	38 x 6.4	1.54
	44 x 3.2	1.01
	44 x 4.8	1.53
	44 x 6.4	1.83
	50 x 3.2	1.14
	50 x 4.0	1.42
	50 x 4.8	1.74
	50 x 6.4	2.12
	54 x 4.8	1.78
	64 x 3.2	1.48
	64 x 6.4	2.80
	76 x 3.2	1.77
	76 x 5.0	2.70
	76 x 6.4	3.39
	76 x 9.5	5.29
	101 x 3.2	2.38
	101 x 5.0	3.61
	101 x 6.4	4.61
	125 x 6.4	5.76
	125 x 9.5	8.55
	125 x 12.7	11.43
	152 x 6.4	7.10
	152 x 9.5	10.40
	152 x 12.7	13.50

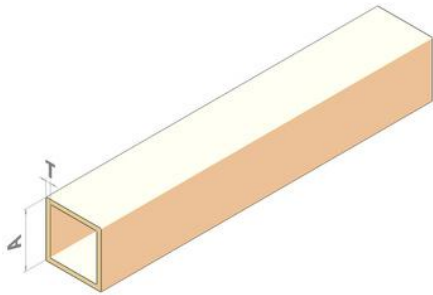

Wide Flange Beam	Dimension (mm) A x B x T	Weight (kg/m)
	76 x 76 x 6.4	2.67
	102 x 102 x 6.4	3.59
	102 x 102 x 6.4	4.50
	102 x 102 x 8.0	5.43
	152 x 152 x 6.4	8.10
	152 x 152 x 9.5	10.80
	203 x 203 x 12.7	14.36
	254 x 254 x 12.7	13.60
	254 x 254 x 12.7	18.04
	305 x 305 x 12.7	21.50

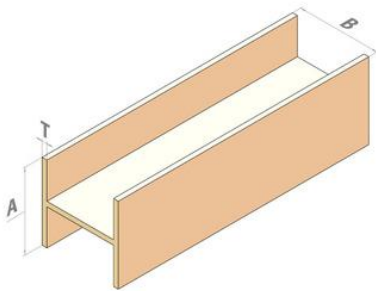

I Beam

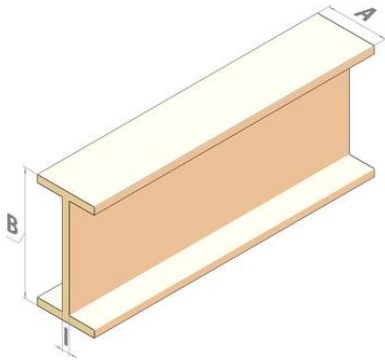

Dimension (mm) A x B x T

Weight (kg/m)

38 x 76 x 6.4	1.77
50 x 102 x 6.4	2.40
76 x 152 x 6.4	3.59
76 x 152 x 9.5	5.32
102 x 203 x 9.5	7.20
102 x 203 x 12.7	9.50
127 x 254 x 9.5	9.00
127 x 254 x 12.7	11.90
152 x 305 x 9.5	10.74
152 x 305 x 12.7	14.30

Flute Tube

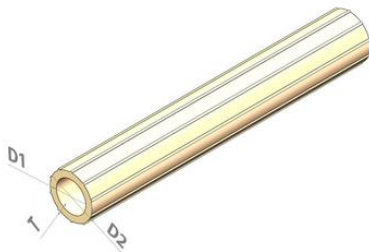

Dimension (mm) D1 x D2 x T

Weight (kg/m)

19 x 32 x 6.4	1.20
25 x 32 x 3.5	0.66
28 x 45 x 8.5	1.86
32 x 45 x 6.4	1.10

Kick Plate

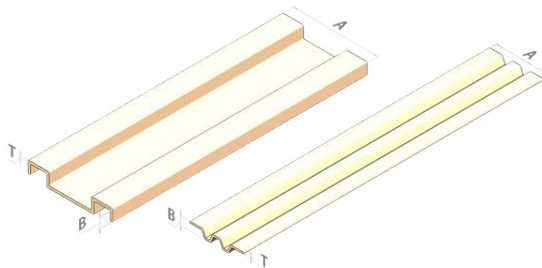

Dimension (mm) A x B x T

Weight (kg/m)

100 x 14 x 3.0 M Type	1.20
100 x 14 x 3.0 W Type	0.66
150 x 15 x 3.2 W Type	1.86
200 x 15 x 3.2	1.10

Round Tube

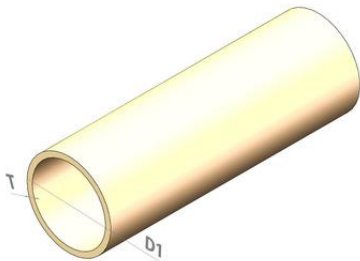

Dimension (mm) D1 x T

Weight (kg/m)

25 x 3.2	0.44
25 x 6.4	0.88
32 x 3.2	0.55
32 x 6.4	.10
38 x 3.2	0.65
38 x 6.4	1.30
42 x 6.4	1.45
44 x 6.4	1.61
48 x 5.0	1.40
50 x 3.2	0.84
50 x 4.0	1.10
50 x 5.0	1.34
50 x 6.4	1.67

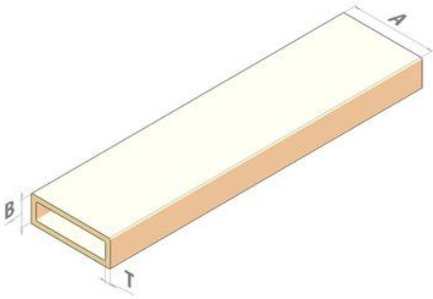

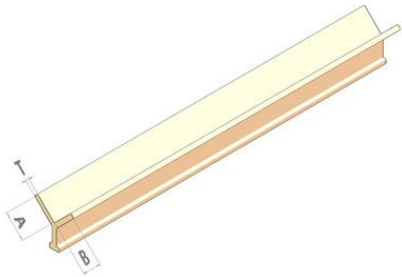

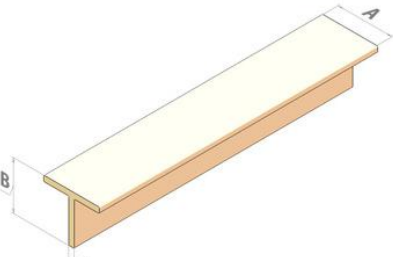
Rectangular Tube	Dimension (mm) A x B x T	Weight (kg/m)
	38 x 25 x 5.0	1.20
	50 x 25 x 3.2	0.87
	50 x 25 x 6.4	1.54
	50 x 38 x 6.4	2.08
	76 x 25 x 5.0	2.33
	91 x 38 x 4.0	1.78
	100 x 50 x 5.0	2.72
	100 x 75 x 5.0	3.15
	112 x 91 x 6.4	4.46
	125 x 75 x 5.0	4.32
	150 x 100 x 6.4	5.76
	186 x 32 x 5.0	3.95
	197 x 44 x 5.0	4.34
	250 x 100 x 8.0	10.36

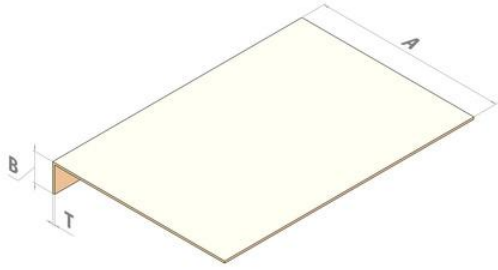
Embedded Angle	Dimension (mm) A x B x T	Weight (kg/m)
	25 x 38 x 6.4	1.40
	38 x 38 x 6.4	1.60
	38 x 50 x 6.4	1.70

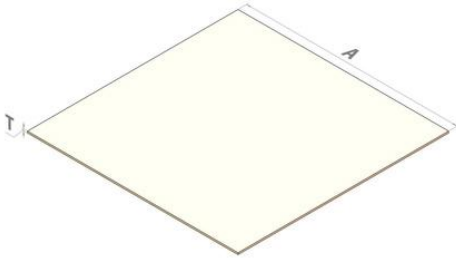
T-Shape	Dimension (mm) A x B x T	Weight (kg/m)
	54 x 32 x 6.0	0.93
	54 x 32 x 5.0	0.78
	54 x 45 x 6.0	1.10
	60 x 55 x 5.0	1.08
	60 x 46 x 6.0	1.20
	78 x 44 x 6.0	1.08

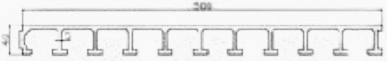
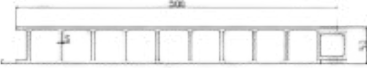
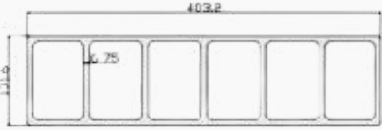
Stair Covers	Dimension (mm) A x B x T	Weight (kg/m)
	55 x 55 x 3.0	0.80
	65 x 10 x 3.0	0.44
	70 x 30 x 3.0	0.71
	100 x 30 x 3.0	0.85
	150 x 20 x 3.0	0.92
	152 x 30 x 3.0	1.20
	200 x 20 x 5.0	2.00
	230 x 30 x 3.0	1.45
	230 x 55 x 4.0	2.10
	250 x 55 x 4.0	2.20
	280 x 55 x 4.0	2.42
	305 x 55 x 3.2	2.10
	345 x 55 x 4.0	2.88

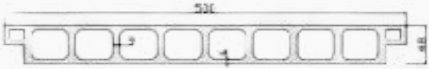
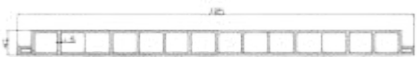
Flat Strip & Flat Sheet	Dimension (mm) A x T	Weight (kg/m)
	15 x 2.5	0.06
	10 x 2.5	0.05
	19 x 6.4	0.23
	38 x 5.0	0.35
	50 x 3.0	0.27
	50 x 4.0	0.36
	90 x 3.0	0.50
	120 x 3.0	0.65
	120 x 10.0	2.16
	615 x 3.2	3.55
	1220 x 3.2	7.03
	1220 x 6.4	14.06
	1220 x 9.5	20.86
	1220 x 12.7	29.50
	1524 x 6.4	7.60
	1524 x 12.7	36.80

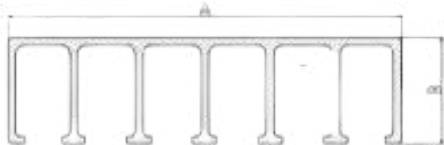
Decking Panel	Dimension (mm)	Weight (kg/m)
	500 x 40 x 5.0	9.86
	500 x 57 x 5.0	14.70
	403.2 x 101.6 x 6.75	18.30
	381 x 120 x 6 x 7.54	19.60
	500 x 48 x 6.0 x 9.0	18.50
	725 x 45 x 4.5	18.20
	900 x 48.5 x 9.0	31.50
Mud Mat	Dimension (mm) A x B x T	Weight (kg/m)
	305 x 47.5 x 6.4	8.65
	305 x 82 x 6.4	11.60

Mechanical Properties			
	ASTM	UNITS	VALUE
Tensile Strength LW	D-638	MPA	207
Tensile Strength CW	D-638	MPA	48
Tensile Modulus LW	D-638	GPA	17.2
Tensile Modulus CW	D-638	GPA	5.5
Compressive Strength LW	D-695	MPA	207
Compressive Strength CW	D-695	MPA	103
Compressive Modulus LW	D-695	GPA	17.2
Compressive Modulus CW	D-695	GPA	6.9
Flexural Strength LW	D-790	MPA	207
Flexural Strength CW	D-790	MPA	69
Flexural Modulus LW	D-790	GPA	12.4
Flexural Modulus CW	D-790	GPA	5.5
Modulus of Elasticity E	Full Section	GPA	19.3
Shear Modulus	/	GPA	3.1
Short Beam Shear	D-2344	MPA	31
Punch Shear	D-256	MPA	69
Bearing Strength LW	D-953	MPA	207
Notched Izod Impact LW	D-256	KJ/m	1.33
Notched Izod Impact CW	D-256	KJ/m	0.21
Physical Properties			
	ASTM	UNITS	VALUE
Barcol Hardness	D-495	/	45
24 Hours Water Absorption	D-570	% max	0.45
Density	D-792	g/cm ³	1.72 ~ 1.94
Coefficient of Thermal Expansion	D-696	10 in/ in/ degrees celcius	8
Electrical Properties			
	ASTM	UNITS	VALUE
Arc Resistance LW	D-495	Seconds	120
Dielectric Strength LW	D-149	Kv/ in	35
Dielectric Strength CW	D-149	Volts/ mil	200
Dielectric Strength PF	D-150	@60hz	5
Polyester & Vinyl Ester Fire Retardant Structural Profiles			
	ASTM	UNITS	VALUE
Flammability Properties	ASTM	UNITS	VALUE
Tunnel Test	E-84	Flame Speed	25 Max
Flammability	D-635	/	Non-Burning



Anti-Slip Product

Our anti-slip products offer various solutions to achieve a broad range of requests from many industrious and conservative markets requiring unique and specified applications. Products in this series are based on our basic gratings and profiles together with further design and fabrications - designed to reduce the risk of slips, falls and other related hazards that you may experience in walkways, working areas, access zones and more.

01

Molded Stair Tread Covers

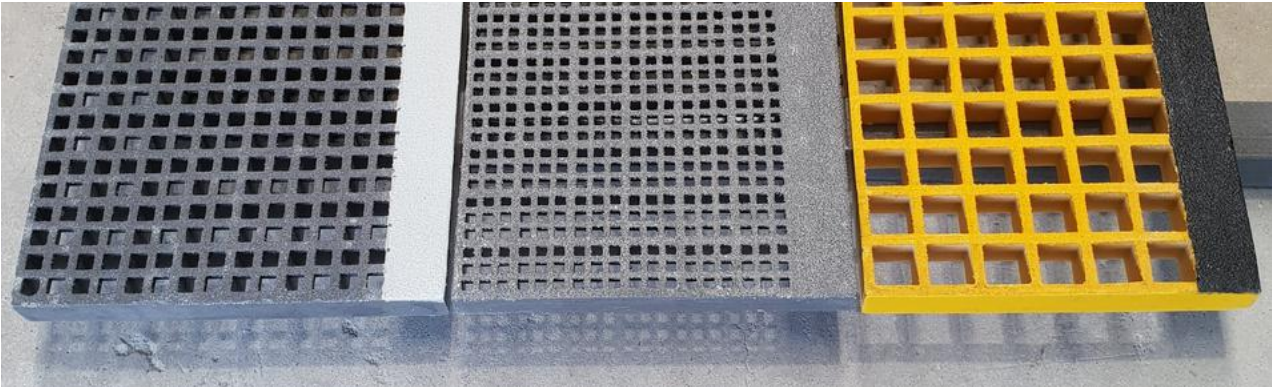

Molded stair tread covers are made utilising our grating together with an angle or strip as the in-built nosing for anti-slip property/ purpose. The most common selection among the gratings is the 38mm x 38mm square mesh, mini mesh and micro mesh options in a 38mm thickness. The standard width among this range is 235mm to 287mm. The OSHA requires anti-slip nosing, built into the leading edge of the tread for the first 32mm is always gritted, and has the contrast colour with the rest of the panel, normally in black.

Another of our Molded Stair Tread Panel is manufactured with inlay nosing in the mold as the whole, which has special small meshes between the regular meshes, allowing to cut to size without the extra work for a hand-closed edge.

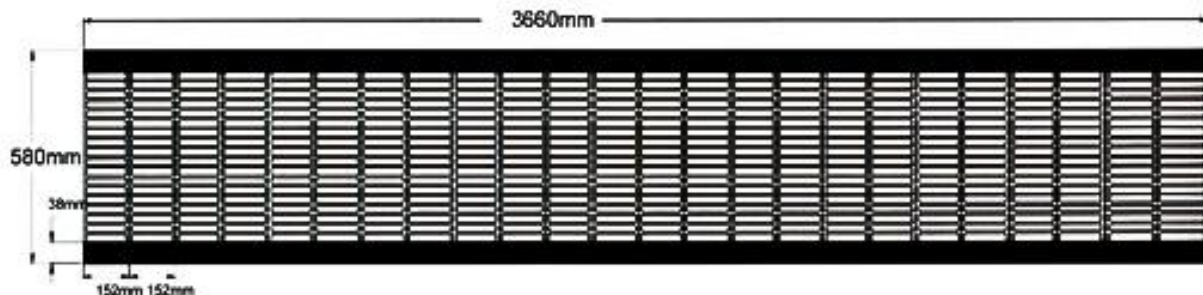
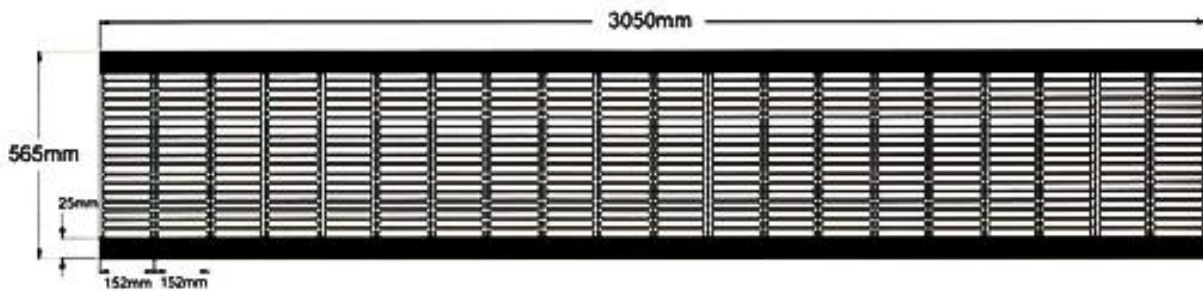

02



Pultruded Stair Tread Cover

Pultruded Stair Tread Covers are made by utilising our pultruded grating together with rectangular tubing or square tubing as the anti-slip nosing. Any of our pultruded gratings can be selected and used as the stair tread to comply with the type of gratings used in other areas of your project.

03

Stair Covers

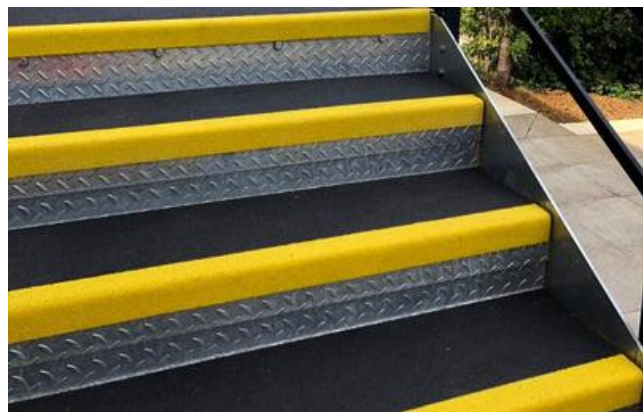

Our Stair Covers are made using pultruded fibre reinforced polymers with a grit applied for anti-slip purposes. A/O (Aluminum Oxide) grit is always recommended to apply as the surface texture builder as it is the most durable for long term usage.

The waterproof surface maintains the panels condition without deterioration or welled expansion. Due to this, our product is highly adaptable to environment conditions. The product can also be conveniently applied and installed over concrete, wood or steel surfaces.

This product can additionally be supplied with a glow-in-the-dark finish, making it an exceptional choice for emergency areas or basements with low/ no lighting.

Feature of the glow-in-the-dark covers:

- Ideal for areas with limited lighting
- Glows for up to 8 hours
- 55mm DDA compliant stair tread nosing
- Builders regulation compliant
- Available with white or yellow nosing

Dimensions (mm)
55 x 55 x 3.0
65 x 10 x 3.0
70 x 30 x 3.0
100 x 30 x 3.0
150 x 20 x 3.0
152 x 30 x 3.0
200 x 20 x 5.0
230 x 30 x 3.0
230 x 55 x 4.0
250 x 55 x 4.0
280 x 55 x 4.0
305 x 55 x 3.2
345 x 55 x 4.0

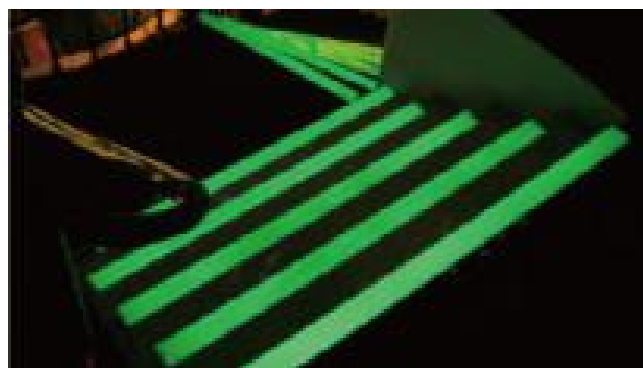

04 Flat Sheet & Strip

Flat Sheet and Strip with anti-slip surfaces are made by the flat sheet or strip with a choice from several variations of grit which can then be applied on one side. Flat Sheet and Strip can be installed on existing wooden decking or where surfaces can be slippery from rains and oils. Various meshes of the grit are available to meet different anti-slip requirements. This type of application can be used for walkways, stairs, jetty's, platforms and more.



05 Ramps

Grating Edge Ramps are an ideal solution for wheelchair users and vehicles where a height difference between floors is apparent and limits accessibility. The regular thickness of our Grating Edge Ramps is 25mm or 50mm. The width of the ramp is 122mm, 3 meshes wide. 2 meshes with slope is covered with a flat strip.





Ladders

Our corrosion resistant fiberglass ladders can be installed in a variety of applications where safety, low maintenance, easy installation and long service life are essential. The standard ladder materials are made by pultrusion. By utilising a high content of fibreglass as well as excellent properties, we are able to deliver for applications that require materials to be lightweight, long lasting, low maintenance, fire retardant and chemical resistant.

Description	Dimension
Maximum length without splice	7300mm
Ladder Post Splice, Solid Square Bar	38mm x 38mm, 200mm long
Maximum Ladder Length with Cage	10200mm
Outside Width (outside rail to rail)	500mm
Rung Spacing (Centre to Centre)	300mm
Outside Diameter of Rung, Fluted Tube	32mm
Wall Thickness of Rung	6.4mm
Ladder Post Square Tube	50.8 x 50.8 x 6.4mm
Ladder Rung Gasket	Black Rubber
Rivet to Fix Rings to Ladder Post	4 x 20mm

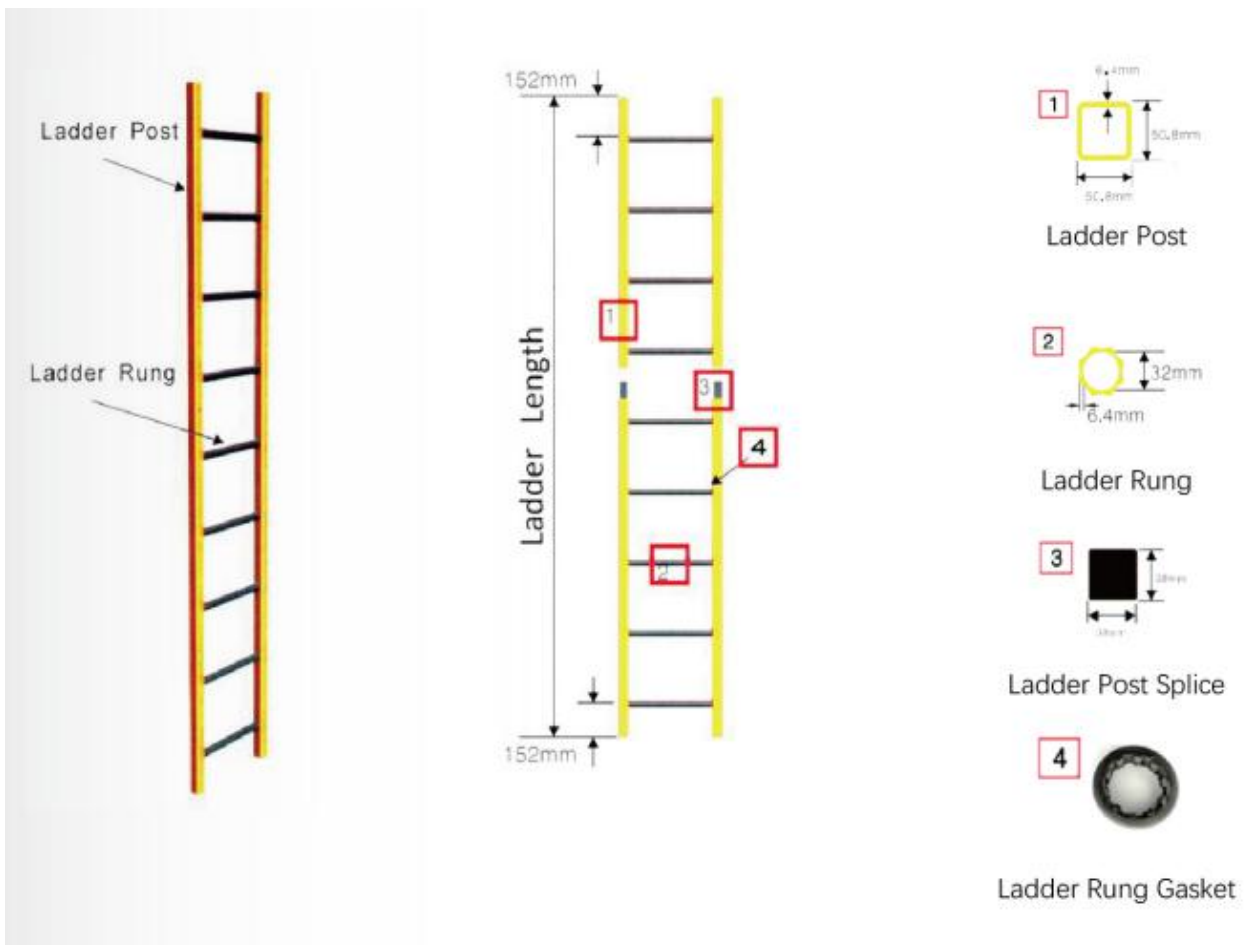

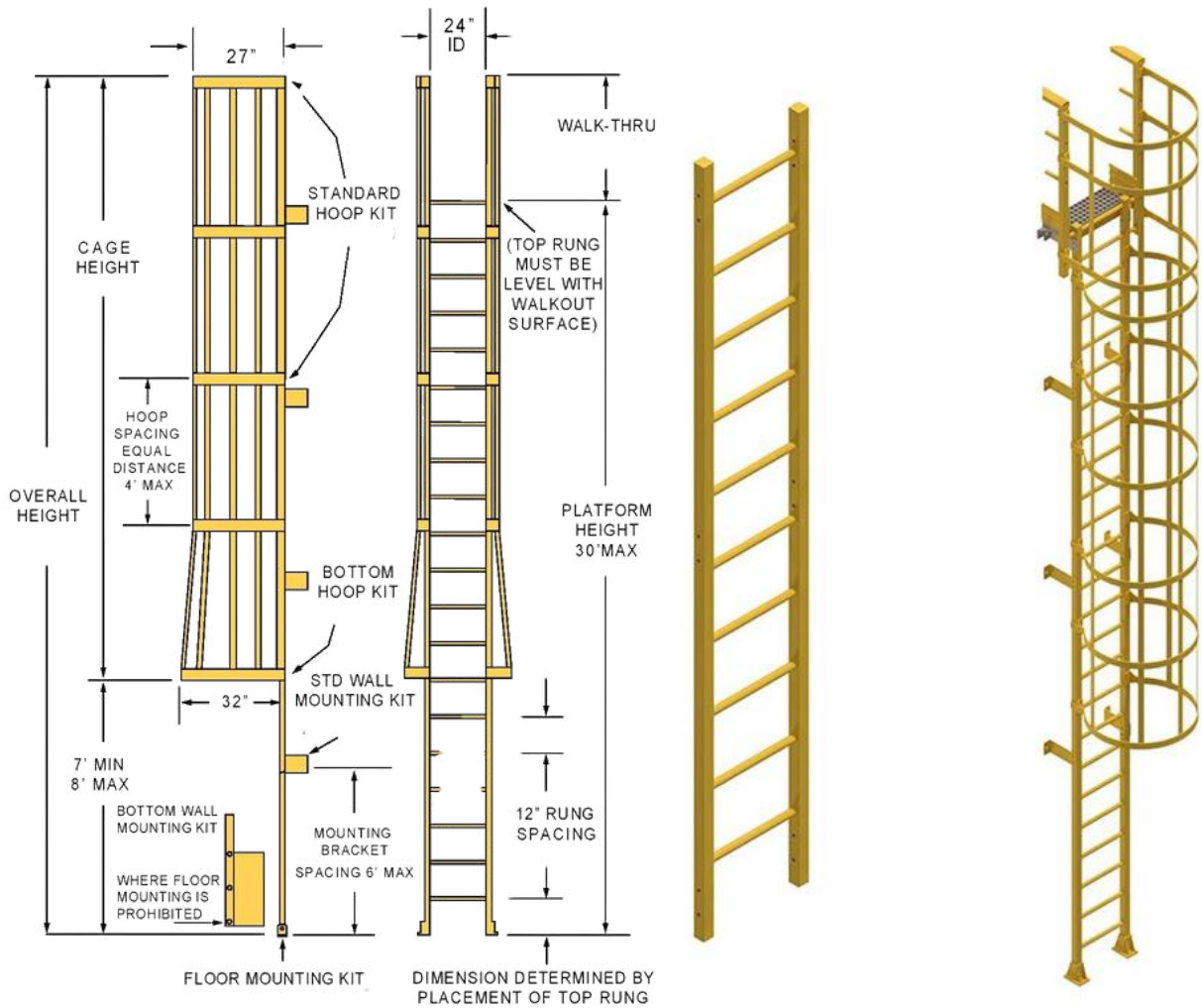

Product	Description
Ladder Hoop	76mm wide x 13mm thick, hand lay-up with predrilled holes (with necessary bolt assemblies)
Hoop Bracket	75mm x 140mm, 10mm thick, U Shape, Predrilled Holes (with necessary bolt assemblies)
Cage Strip	C Channel, 50mm x 14mm x 3mm, Made by Pultrusion
Wall Mount Bracket	76mm x 200mm x 9.5mm angle, 457mm Long, Made by Pultrusion
Floor Mount	102mm x 102mm x 9.5mm angle, made by pultrusion. Two per set (with necessary bolt assemblies)
Foot Base Mount (Optional)	Foot Base made by BMC

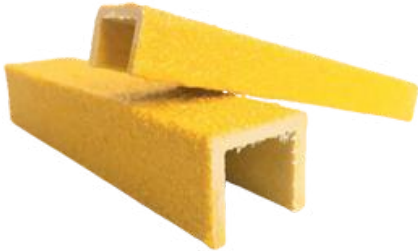

Ladder Rung

Our ladder rung is a solution for replacing an existing steel or wooden ladder where higher quality anti-slip property is required. Easy to install, long lasting and corrosion resistant - for example, these rungs can be used in subsea areas, chemical factories and water treatments plants.

C Shape Ladder Rung	Dimension (mm) D x T
	20 x 3.0mm
	25 x 3.0mm
	30 x 3.0mm
	35 x 3.0mm
U Shape Ladder Rung	Dimension (mm) A x B x C x T
	20 x 20 x 20 x 3.0mm
	25 x 25 x 25 x 3.0mm
	30 x 30 x 30 x 3.0mm
	38 x 38 x 38 x 30mm





H and Rails

Handrails are assembled by high strength structural shapes for easily installation, light weight and long lasting. This product has excellent chemical resistance and fire-retardant properties. Some application examples include water treatment plants, seaside walkways, platforms in industrial areas, offshore areas and other industrial zones.

Description	Dimension
Distance Between Posts	1500mm as a maximum
Height of Handrail	1220mm as a maximum
Top Rail, Square Tube	50 x 50 x 6.4mm
Middle Rail, Square Tube	50 x 50 x 6.4mm
Insert Splice, Square Tube	38 x 38 x 6.4mm
Kick Plate	100 x 14 x 3mm
Kick Plate Splice, Plate	45mm wide x 101mm long x 6mm thick
90 Degree Kick Plate Splice, Angle	54 x 29 x 6.4mm
90 Degree Handrail Fitting	3 pieces of 152 x 152 x 13mm FRP Angle, 38mm long
Adjustable Handrail Fitting Plastic	39 degrees to 180 degrees
Rivet Connection	4 x 20mm

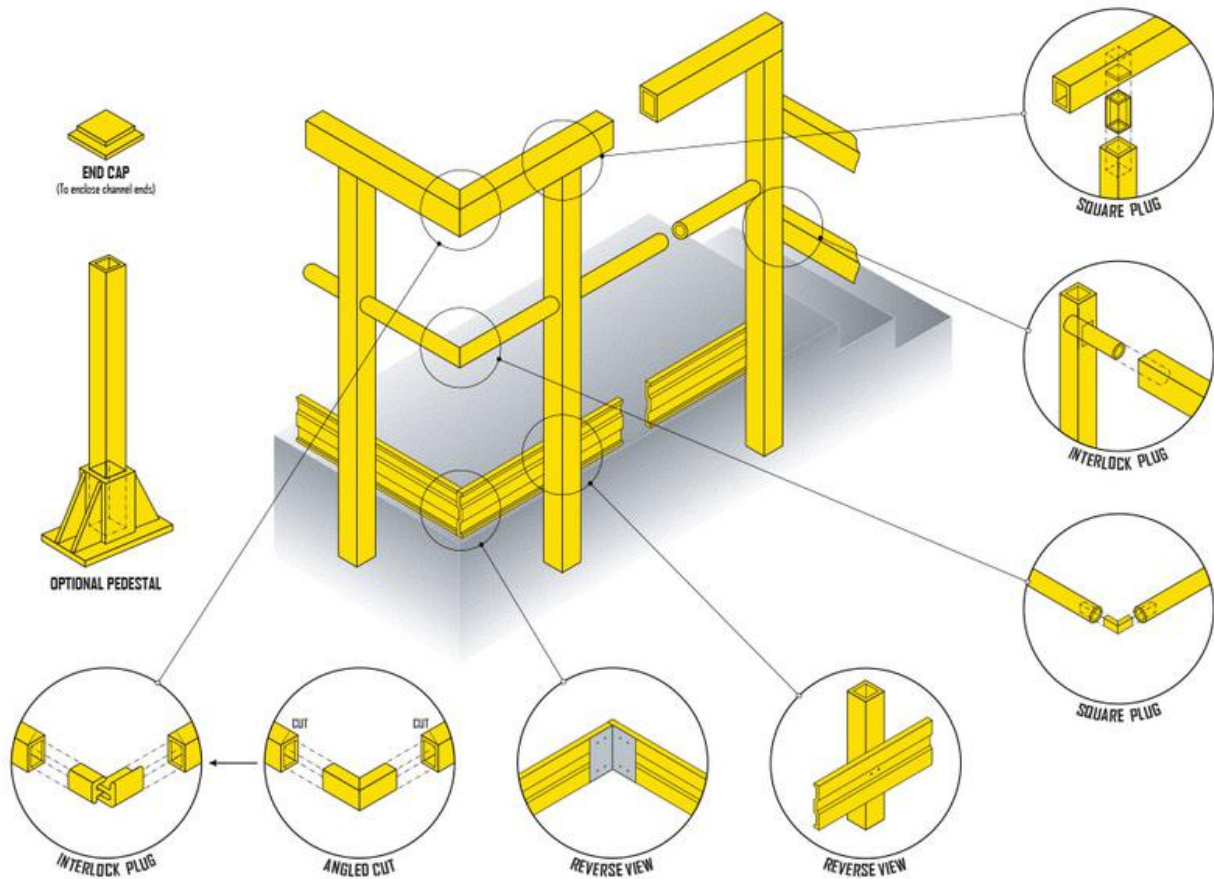

Description	Dimension
Distance Between Post	1500mm as a maximum
Height of Handrail	1220mm as a maximum
Handrail Post, Round Tube	50 x 5mm
Handrail Top Rail, Round Tube	50 x 5mm
Handrail Middle Rail, Round Tube	50 x 5mm
Kick Plate	101 x 14 x 3mm
Kick Plate Splice	45mm wide x 10mm long x 6mm thick
Elbow, BMC	
Tee, BMC	
Cross, BMC	
Foot Base, BMC	
Screws, M5 x 55	2 for Elbow, 2 for Tee, 3 for Cross
Anchor Bolt, M6 x 90	2 Bolts for Foot Base

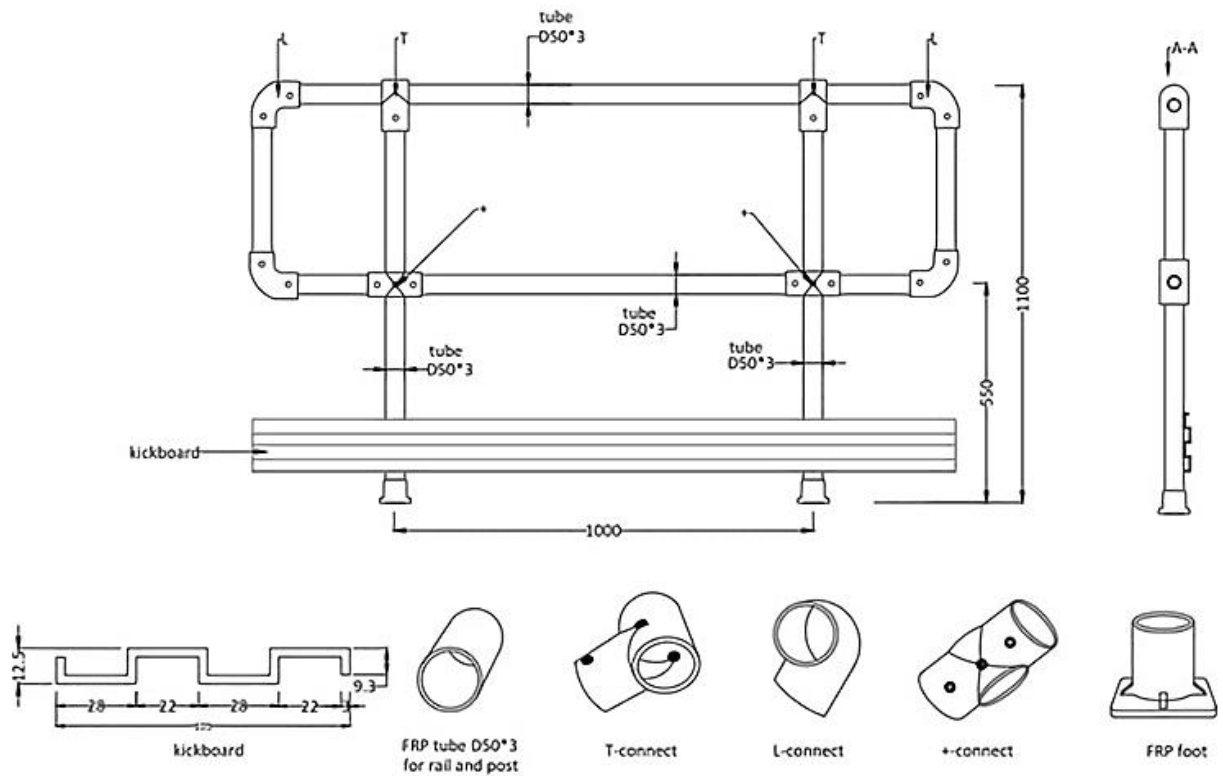



C clips

Our Grating Clips are simple and easy to use solutions for securing gratings or plates to their main frame safely. Their installation is quick, simple and requires minimal maintenance as they are structurally created with stainless steel, making them rust-free and high strength.

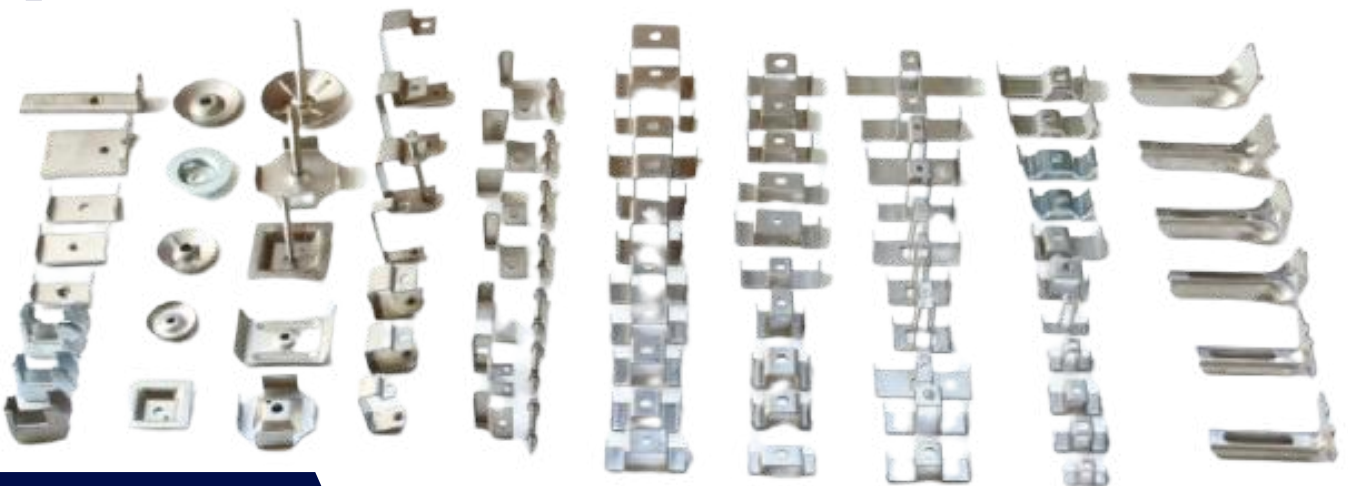



C Clip

C Clips are specifically designed to bring two panels of molded fibreglass gratings together to minimize differential deflections when joints fall between the supports.



L Clip

An alternative option of M Clips, used for securing gratings to the support structure. L Clips are lighter duty fixing clips that hold down one FRP Grating load bar to the base support.

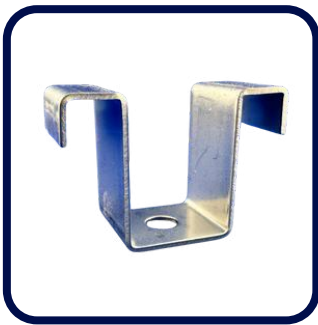

M Clip

M Clip, also known as a saddle down clip, clamps two fibreglass grating load bars to the support. It provides excellent holding capacities. M Clips are recommended for stair tread panels and most kinds of gratings (open mesh, mini mesh and pultruded).



W Clip

This round cover type fastener is used for holding down plates and covered fibreglass gratings. The W Clips recessed center allows the fastener to sit flush with this ADA compliant (<6.4mm high) hold down clip.



G Clamp

Our G Clamp is a fast, easy and very dependable grating fastener for securing FRP Gratings. G-Clamps can be easily fastened from the above, with mere hand tools, with no extra need of drilling, tapping, cutting or welding.



J Clamp

A J Clamp is a bottom clamp which we utilise together with other top clips. It is used to help fasten grating together with a frame, where you may not be able to drill holes.



Chemical Resistance

- C** = Continuous exposure of the grating to the chemical environment listed at the temperature listed.
- F** = Frequent exposure of the grating to splashes and spills from the chemical environment listed with that environment at the temperature listed.
- I** = Infrequent exposure of the grating to splashes and spills from the chemical environment listed with that environment at the temperature listed and the spill immediately cleaned up or washed from grating.
- N** = Not recommended for the concentrations and temperatures listed.
- MAX Temperature is 85 degrees Celsius for Vinyl Grating.**
- MAX Temperature is 70 degrees Celsius for Isophthalic grating.**
- MAX Temperature is 65 degrees Celsius for General polyester grating.**

The corrosion resistance data listed in this document is for general information only. Resin manufacturers have provided test data which indicates that the specific resin can withstand the corrosion conditions listed above. Grating FRP Australia believes the information to be true and accurate but no guarantee is expressed or implied as to specific performance. Testing for specific environments is recommended. Responsibility for claims arising from breach of warranty, negligence or otherwise is limited to the purchase price of the material sold by Grating FRP Australia.

Chemical Environment	Concentration %	Temperature Degrees Celsius	Vinyl Ester	Isophthalic	General Purpose
Acetic Acid	50	MAX	C	F	C
Acetone	100	23	I	I	N
Aluminum Hydroxide	ALL	MAX	C	C	C
Aluminum Chloride	ALL	MAX	C	C	C
Ammonium Bicarbonate	ALL	48	C	C	C
Ammonium Bicarbonate	15	48	C	F	F
Ammonium Hydroxide	50	48	F	F	I
Ammonium Sulfate	20	26	I	N	N
Barium Sulfate	ALL	48	C	C	F
Benzene	ALL	MAX	C	C	C
Benzoic Acid (SAT)	100	65	I	N	N
Borax (SAT)	SAT	MAX	C	F	C
Calcium Carbonate	SAT	MAX	C	F	F
Calcium Hydroxide	ALL	MAX	C	F	C
Calcium Hypochlorite	25	MAX	F	F	I
Calcium Nitrate	ALL	MAX	I	I	N
Carbon Tetrachloride	ALL	26	C	C	C
Chlorine - Dry Gas	100	MAX	I	N	F
Chlorine Water (SAT)	ALL	48	C	F	N
Chromic Acid	SAT	65	I	N	N
Citric Acid	50	MAX	C	N	C
Copper Chloride	ALL	MAX	I	C	C
Copper Cyanide	ALL	60	I	C	I
Copper Nitrate	ALL	MAX	C	I	C
Crude Oil (Sweet or Sour)	ALL	MAX	C	C	C
Diesel Fuel	ALL	37	F	C	C
Ethanol	10	48	C	F	F
Ethanol	50	48	C	I	I
Ethanol Glycol	ALL	65	C	F	FI
Ferric Chloride	100	MAX	C	C	C
Ferric Nitrate	ALL	MAX	C	C	C
Ferrous Chloride	ALL	MAX	C	C	C
Fluorosilicic Acid	10	23	F	F	I
Formaldehyde (0-50%)	50	48	F	I	I
Gasoline	ALL	48	C	F	F
Glucose	ALL	48	C	C	C
Glycerin	100	MAX	C	F	F
Hydrobromic Acid	50	MAX	I	I	N
Hydrobromic Acid	10	MAX	F	F	F

Chemical Environment	Concentration %	Temperature Degrees Celsius	Vinyl Ester	Isophthalic	General Purpose
Hydrobromic Acid	37	MAX	I	I	I
Hydrogen Peroxide	30	26	F	N	N
Lactic Acid	100	MAX	C	C	C
Lithium Chloride (SAT)	SAT	MAX	N	N	N
Magnesium Chloride	ALL	MAX	C	C	C
Magnesium Nitrate	ALL	MAX	C	C	C
Magnesium Sulphate	ALL	MAX	C	C	C
Mercuric Chloride	ALL	MAX	C	C	C
Mercurous Chloride	ALL	MAX	C	F	F
Nickle Chloride	ALL	MAX	C	C	C
Nickle Sulphate	ALL	MAX	C	C	C
Nitric Acid	20	48	I	I	I
Oxalic Acid	ALL	65	C	F	F
Perchloric Acid	30	32	I	I	I
Phosphoric Acid	80	MAX	C	C	F
Potassium Chloride	ALL	MAX	C	C	C
Potassium Dichromate	ALL	MAX	C	C	C
Potassium Nitrate	ALL	MAX	C	C	C
Potassium Sulfate	ALL	MAX	C	C	C
Propylene Glycol	ALL	MAX	C	F	F
Sodium Acetate	ALL	MAX	C	C	C
Sodium Bisulfate	ALL	26	C	I	I
Sodium Bromide	ALL	26	C	C	C
Sodium Cyanide	ALL	26	F	I	I
Sodium Hydroxide	10	MAX	I	N	N
Sodium Hydroxide	50	MAX	N	N	N
Sodium Nitrate	ALL	MAX	C	C	C
Sodium Sulfate	ALL	MAX	C	C	C
Sulfuric Acid	10	MAX	C	F	F
Sulfuric Acid	25	MAX	F	F	F
Sulfuric Acid	75	37	I	I	I
Tartaric Acid	ALL	MAX	C	F	F
Vinegar	ALL	MAX	C	F	F
Water (Distilled)	ALL	MAX	C	C	C
Zinc Nitrate	100	MAX	C	C	C
Zinc Sulfate	100	MAX	C	C	C



Moulded Grating Load Tables

Appendix 1:

Load Table for Molded Grating

1. Deflection is in mm.
2. Walking loads, typically 65-80kg maximum are recommended for pedestrian traffic. Deflections for worker comfort are typically limited to the lesser of 10mm or **Clear Span** divided by 125; for a firmer feel, limit deflection to the lesser of 6.4mm or **Clear Span** divided by 200.
3. The allowable Loads in this table are for **Static Load Conditions** at ambient temperatures only. Allowable loads for impact or dynamic conditions should be a maximum of **One-Half** the values shown. Long term loads will result in added deflection due to the creep in the material and will also require higher safety factors to ensure acceptable performance. For applications at elevated temperatures, please consult with Grating FRP Australia. The design is further referenced to the ASCE Structural Plastics Design Manual.
4. All Gratings were tested in accordance with ANSI Standard; FRP Composites Grating Manual for Pultruded and Molded Grating and Stair Treads.

Concentrated Line Load

38 x 38mm mesh



Span (mm)	Height (mm)	Load kg/m of width							Max Load (kg/m)
		75	150	300	450	600	750	1500	
300	20	0.25	0.53	1.12	1.71	2.38	2.86	/	4,470
	25	<0.25	0.42	0.88	1.45	2.27	2.62	/	5,970
	30	<0.25	0.28	0.52	0.78	1.17	1.54	3.12	9,924
	38	/	<0.25	0.29	0.51	0.66	0.77	1.57	17,120
	60	/	/	/	0.35	0.49	0.65	1.34	25,328
450	20	0.76	0.62	3.34	5.02	/	/	/	2,980
	25	0.56	1.15	2.16	3.08	4.16	4.76	/	3,910
	30	0.28	0.51	1.13	1.53	2.09	2.63	/	4,828
	38	<0.25	0.47	0.91	1.36	1.86	2.33	4.81	12,980
	60	/	<0.25	0.45	0.67	0.89	1.14	2.35	19,445
600	20	1.79	3.61	7.36	/	/	/	/	2,235
	25	0.87	1.71	3.51	5.2	6.72	/	/	2,924
	30	0.53	1.29	2.31	3.62	4.82	5.96	/	4,089
	38	0.36	0.65	1.25	1.35	2.47	3.08	6.36	8,720
	60	<0.25	0.31	0.63	0.92	1.2	1.49	3.01	13,391
750	20	2.79	5.6	11.4	/	/	/	/	1,788
	25	1.36	4.47	9.37	/	/	/	/	2,287
	30	1.27	2.61	4.91	7.44	11.06	/	/	3,175
	38	0.63	1.14	2.17	3.24	4.36	5.45	11.94	7,270
	60	0.35	0.71	1.38	2.11	2.81	3.49	7.03	11,331
900	20	5.33	10.81	/	/	/	/	/	1,490
	25	2.91	5.92	12.12	/	/	/	/	1,948
	30	1.79	3.91	7.76	11.51	/	/	/	2,641
	38	0.87	1.81	3.68	5.56	7.42	9.31	/	5,817
	60	0.47	0.97	1.89	2.87	3.82	4.74	9.51	9,266
1200	20	14.77	/	/	/	/	/	/	/
	25	5.72	11.64	/	/	/	/	/	1,431
	30	3.61	7.91	14.37	/	/	/	/	1,286
	38	2.26	4.75	9.68	14.63	/	/	/	3,755
	60	1.08	2.18	4.42	6.62	8.79	11.02	22.15	6,366

Uniform Load



38 x 38mm mesh

Span (mm)	Height (mm)	Load kg/m ²							Max Load (kg/m ²)
		150	350	500	750	1000	1500	2500	
300	20	<0.25	<0.25	0.25	0.51	0.76	1.02	1.53	25,300
	25	<0.25	<0.25	<0.25	<0.25	0.26	0.31	0.64	31,625
	30	<0.25	<0.25	<0.25	<0.25	<0.25	0.26	0.53	33,000
	38	<0.25	<0.25	<0.25	<0.25	<0.25	<0.25	0.42	41,800
	60	/	/	/	/	/	/	/	
450	20	0.38	1.02	1.53	2.29	3.05	4.58	7.62	16,608
	25	0.30	0.38	0.62	0.94	1.22	1.85	2.75	20,759
	30	0.25	0.32	0.52	0.78	1.02	1.54	2.29	21,662
	38	0.20	0.25	0.41	0.62	0.81	1.22	1.81	27,439
	60	/	/	0.41	0.61	0.82	1.22	2.03	60,654
600	20	1.23	3.08	4.57	7.12	9.41	/	/	9,951
	25	0.98	1.24	1.85	2.75	3.35	5.18	8.86	12,439
	30	0.82	1.03	1.54	2.29	2.79	4.32	7.38	12,980
	38	0.65	0.81	1.22	1.81	2.20	5.64	14.10	16,441
	60	0.33	0.41	0.62	0.92	1.12	2.86	7.14	36,344
750	20	1.61	5.84	8.89	/	/	/	/	6,360
	25	1.28	3.05	4.57	6.86	9.15	/	/	7,950
	30	1.07	2.54	3.81	5.72	7.62	11.69	/	8,296
	38	0.48	2.01	3.01	4.51	/	/	/	10,508
	60	0.43	1.02	1.52	2.29	4.75	7.13	/	23,229
900	20	3.21	8.91	12.03	/	/	/	/	4,414
	25	2.57	7.13	9.62	/	/	/	/	5,518
	30	2.14	4.58	7.11	10.67	/	/	/	5,758
	38	1.69	3.62	5.61	8.42	/	/	/	7,293
	60	0.68	1.83	2.84	4.27	6.41	9.62	/	16,122
1200	20	8.87	12.37	/	/	/	/	/	2,262
	25	7.10	9.90	12.46	/	/	/	/	2,827
	30	5.91	8.25	11.78	/	/	/	/	3,392
	38	4.67	6.51	9.30	13.95	/	/	/	4,297
	60	2.37	3.30	4.71	7.07	9.43	14.15	/	9,499

Concentrated Point Load

38 x 38mm mesh



Span (mm)	Height (mm)	Load k/g							
		150	350	500	750	1000	1500	2500	3000
300	20	/	0.55	0.74	1.29	1.72	2.23	3.53	4.36
	25	/	0.44	0.59	1.03	1.37	1.78	2.82	3.49
	30	/	0.37	0.49	0.86	1.14	1.48	2.35	2.91
	38	/	0.29	0.39	0.68	0.90	1.17	1.86	2.29
	60	/	/	/	/	/	/	/	/
450	20	0.33	0.83	1.11	1.94	2.58	3.34	5.29	6.54
	25	0.26	0.66	0.89	1.55	2.06	2.67	4.23	5.23
	30	/	0.55	0.74	1.29	1.72	2.23	3.53	4.36
	38	/	0.43	0.59	1.02	1.36	1.76	2.78	3.44
	60	/	/	/	0.37	0.49	0.64	1.01	1.25
600	20	0.93	1.94	2.53	3.98	5.65	7.65	/	/
	25	0.74	1.55	2.02	3.18	4.52	6.12	/	/
	30	0.62	1.29	1.68	2.65	3.77	5.10	8.37	/
	38	0.49	1.02	1.33	2.09	2.97	4.03	6.71	/
	60	/	0.37	0.48	0.76	1.08	1.46	2.43	2.92
750	20	1.58	3.68	4.73	7.49	10.99	/	/	/
	25	1.26	2.94	3.78	5.99	8.79	/	/	/
	30	1.05	2.45	3.15	4.99	7.33	/	/	/
	38	0.83	1.93	2.49	3.94	5.78	7.84	/	/
	60	0.30	0.70	0.90	1.43	2.09	2.84	4.73	5.68
900	20	2.23	5.40	6.91	11.01	16.33	/	/	/
	25	1.78	4.32	5.53	8.81	13.06	/	/	/
	30	1.48	3.60	4.61	7.34	10.88	/	/	/
	38	1.17	2.84	3.64	5.80	8.59	11.65	/	/
	60	0.42	1.03	1.32	2.10	3.11	4.22	7.03	8.44
1200	20	3.69	9.28	12.98	/	/	/	/	/
	25	2.95	7.42	10.38	15.06	/	/	/	/
	30	2.46	6.18	8.65	12.55	/	/	/	/
	38	1.94	4.88	6.83	9.91	14.56	/	/	/
	60	0.70	1.77	2.47	3.59	5.27	7.16	11.39	/

Concentrated Line Load

40 x 40mm mesh



Span (mm)	Height (mm)	Load kg/m of width							Max Load (kg/m)
		75	150	300	450	600	750	1500	
300	25	<0.25	0.44	0.89	1.44	2.28	2.61	/	5,687
	30	<0.25	0.29	0.54	0.81	1.29	1.68	3.42	9,724
	40	/	<0.25	0.3	0.52	0.67	0.78	1.58	17,010
450	25	0.57	1.17	2.14	3.12	4.16	4.79	/	3,878
	30	0.3	0.53	1.07	1.63	2.13	2.82	5.81	4,733
	40	<0.25	0.48	0.92	1.37	1.87	2.35	4.84	12,680
600	25	0.86	1.73	3.53	5.19	6.75	/	/	2,864
	30	0.52	1.31	2.33	3.65	4.86	6.03	/	3,898
	40	0.38	0.67	1.28	1.89	2.51	3.38	6.86	8,498
750	25	1.34	4.49	9.41	/	/	/	/	2,094
	30	1.29	2.63	4.91	7.47	11.36	/	/	2,871
	40	0.65	1.18	2.23	3.36	4.24	5.49	/	6,970
900	25	2.94	5.95	12.25	/	/	/	12.07	1,784
	30	1.89	3.95	7.83	11.73	/	/	/	2,442
	40	0.91	1.84	3.75	5.69	7.57	9.71	/	5,537
1200	25	5.81	11.96	/	/	/	/	/	1,358
	30	3.63	7.96	14.67	/	/	/	/	1,235
	40	2.35	5.02	9.87	15.01	/	/	/	3,455

Uniform Load

40 x 40mm mesh



Span (mm)	Height (mm)	Load kg/m ²							Max Load (kg/m ²)
		150	350	500	750	1000	1500	2500	
300	25	<0.25	<0.25	<0.25	<0.25	0.27	0.33	0.67	30,044
	30	<0.25	<0.25	<0.25	<0.25	<0.25	0.27	0.56	31,350
	40	<0.25	<0.25	<0.25	<0.25	<0.25	<0.25	0.42	39,710
450	25	0.32	0.40	0.66	0.99	1.29	1.95	2.89	19,721
	30	0.26	0.34	0.55	0.82	1.07	1.62	2.41	20,579
	40	0.20	0.25	0.41	0.62	0.81	1.22	1.81	26,067
600	25	1.04	1.30	1.95	2.89	3.52	5.46	9.32	11,817
	30	0.86	1.08	1.62	2.41	2.94	4.55	7.77	12,331
	40	0.65	0.81	1.22	1.81	2.20	6.43	/	15,619
750	25	1.35	3.21	4.81	7.22	9.63	/	/	7,553
	30	1.13	2.67	4.01	6.02	8.02	12.31	/	7,881
	40	0.84	2.01	3.01	4.51	8.91	/	/	9,983
900	25	2.70	7.51	10.13	/	/	/	/	5,242
	30	2.25	4.82	7.48	11.23	/	/	/	5,470
	40	1.69	3.62	5.61	8.42	11.18	/	/	6,929
1200	25	7.74	10.42	14.88	/	/	/	/	2,686
	30	6.22	8.68	12.40	/	/	/	/	5,470
	40	1.69	3.62	5.61	8.32	11.18	/	/	6,929

Concentrated Point Load

40 x 40mm mesh



Span (mm)	Height (mm)	Load kg							
		150	350	500	750	1000	1500	2500	3000
300	25	/	0.46	0.62	1.08	1.44	1.87	2.96	3.66
	30	/	0.35	0.47	0.82	1.08	1.41	2.23	2.75
	40	/	0.26	0.35	0.61	0.81	1.05	1.67	2.06
450	25	0.27	0.69	0.93	1.63	2.16	2.80	4.44	5.49
	30	0.25	0.58	0.78	1.36	1.81	2.34	3.71	4.59
	40	/	0.43	0.59	1.02	.36	1.76	2.78	3.44
600	25	0.78	1.63	2.12	3.34	4.75	6.43	/	/
	30	0.65	1.36	1.77	2.79	3.96	5.37	8.81	/
	40	0.49	1.02	1.33	2.09	2.97	4.03	6.61	/
750	25	1.32	3.09	3.97	6.29	9.23	/	/	/
	30	1.11	2.58	3.32	5.25	7.71	/	/	/
	40	0.83	1.93	2.49	3.94	5.78	7.82	/	/
900	25	1.87	4.54	5.81	9.25	13.71	/	/	/
	30	1.56	3.79	4.85	7.73	11.46	/	/	/
	40	1.17	2.84	3.64	.80	8.59	/	/	/
1200	25	3.10	7.79	10.90	15.81	/	/	/	/
	30	2.59	6.51	9.11	13.21	/	/	/	/
	40	1.94	4.88	6.83	9.91	13.22	/	/	/

Concentrated Line Load

50 x 50mm mesh



Span (mm)	Height (mm)	Load kg/m of width							Max Load (kg/m)
		75	150	300	450	600	750	1500	
300	25	<0.25	<0.25	0.43	0.62	0.82	0.94	1.93	15,138
	30	0.29	0.32	0.43	0.49	0.65	0.75	1.51	18,922
	40	0.28	0.31	0.41	0.47	0.63	0.72	1.45	22,526
450	25	0.27	0.56	1.03	1.47	2.13	2.89	5.96	11,467
	30	0.32	0.45	0.82	1.17	1.69	2.29	4.72	14,346
	40	0.31	0.42	0.74	0.92	1.22	.21	4.52	17,078
600	25	0.45	0.79	1.48	2.29	2.87	3.54	7.18	7,710
	30	0.36	0.62	1.16	1.81	2.27	2.81	5.65	9,638
	40	0.35	0.58	1.06	.76	2.16	2.56	5.23	11,473
750	25	0.64	1.33	2.37	3.61	4.69	6.08	12.21	6,412
	30	0.51	1.06	1.88	.81	3.71	4.83	9.69	8,040
	40	0.46	0.91	1.58	2.36	3.46	4.57	9.14	9,566
900	25	1.93	2.11	4.23	5.46	6.49	7.73	1.58	5,148
	30	0.74	1.87	3.67	4.63	5.56	6.63	12.86	6,443
	40	1.51	1.67	3.37	4.33	5.16	6.13	12.46	7,780
1200	25	2.09	4.27	8.68	10.92	13.17	/	/	3,421
	30	1.71	3.58	7.12	8.97	11.13	14.06	/	4,276
	40	1.67	3.41	6.94	8.72	10.52	13.32	/	5,843

Uniform Load

50 x 50mm mesh



Span (mm)	Height (mm)	Load kg/m ²							Max Load (kg/m ²)
		150	350	500	750	1000	1500	2000	
300	40lt	<0.25	<0.25	<0.25	<0.25	<0.25	<0.25	0.53	31,268
	50lt	<0.25	<0.25	<0.25	<0.25	<0.25	<0.25	0.43	39,085
	50	<0.25	<0.25	<0.25	<0.25	<0.25	<0.25	0.39	53,602
450	40lt	0.25	0.32	0.51	0.77	1.01	1.52	2.26	20,525
	50lt	<0.25	<0.25	0.41	0.62	0.81	1.22	1.81	25,656
	50	<0.25	<0.25	0.30	0.45	0.59	0.89	1.32	35,186
600	40lt	0.81	1.02	1.52	2.26	2.75	8.04	/	12,299
	50lt	0.65	0.81	1.22	1.81	2.20	6.33	/	15,373
	50	0.47	0.59	0.89	1.32	1.61	4.69	6.13	21,083
750	40lt	1.06	2.51	3.76	5.64	11.14	/	/	7,861
	50lt	0.84	2.01	3.01	4.51	8.91	/	/	9,826
	50	0.62	1.46	2.19	3.29	6.50	9.23	/	13,475
900	40lt	2.11	4.52	7.02	10.52	13.98	/	/	5,456
	50lt	1.69	3.62	5.61	8.42	11.18	/	/	6,820
	50	1.23	2.64	4.09	6.14	8.15	/	/	9,353
1200	40lt	2.11	4.52	7.02	10.52	13.98	/	/	5,456
	50lt	4.67	6.51	9.30	12.56	/	/	/	4,018
	50	3.40	4.75	6.78	9.16	12.07	/	/	5,510

Concentrated Point Load

50 x 50mm mesh



Span (mm)	Height (mm)	Load kg							
		150	350	500	750	1000	1500	2500	3000
300	40lt	/	0.47	0.62	0.97	1.38	1.86	3.06	/
	50lt	/	0.46	0.60	0.95	1.35	1.82	2.99	/
	50	/	0.37	0.48	0.76	1.08	1.47	2.41	2.89
450	40lt	0.38	0.79	1.03	1.61	2.29	3.11	5.10	/
	50lt	0.33	0.69	0.90	1.42	2.02	2.73	4.49	/
	50	0.27	0.56	0.73	1.14	1.63	2.20	3.61	4.34
600	40lt	0.56	1.17	1.52	2.39	3.40	4.60	7.55	/
	50lt	0.49	1.03	1.34	2.10	2.99	4.05	6.65	/
	50	0.39	0.83	1.08	1.69	2.41	3.26	5.35	6.42
750	40lt	0.95	2.21	2.84	4.50	6.61	8.94	/	/
	50lt	0.83	1.95	2.50	3.96	5.82	7.87	/	/
	50	0.67	1.57	2.01	3.19	4.68	6.33	9.87	/
900	40lt	1.34	3.25	4.16	6.62	9.82	/	/	/
	50lt	1.18	2.26	3.66	5.83	8.64	/	/	/
	50	0.95	2.30	2.95	4.69	6.96	10.11	/	/
1200	40lt	2.22	5.58	7.81	11.32	15.11	/	/	/
	50lt	1.95	4.91	6.87	9.97	13.30	/	/	/
	50	1.57	3.95	5.53	8.02	10.71	15.53	/	/

Concentrated Line Load
25 x 100mm mesh



Span (mm)	Height (mm)	Load kg/m of width							Max Load (kg/m)
		75	150	300	450	600	750	1500	
300	25	0.33	0.49	0.74	0.99	1.29	1.52	3.06	9,442
	30	<0.25	0.25	0.63	0.87	1.15	1.44	2.74	10,143
	25HD	<0.25	0.25	0.63	0.86	1.13	1.46	2.76	10,058
	38	<0.25	<0.25	0.56	0.67	0.87	1.04	1.85	13,442
450	25	0.61	1.11	2.11	3.09	4.11	5.15	/	6,878
	30	0.51	.76	1.79	2.57	3.30	4.3	/	7,329
	25HD	0.52	0.77	1.78	2.56	3.31	4.32	/	7,265
	38	0.41	0.73	1.41	2.21	2.74	3.42	4.31	10,454
600	25	0.87	1.73	3.47	5.19	6.92	/	/	4,305
	30	0.74	1.63	3.17	5.04	6.73	/	/	5,903
	25HD	0.76	1.62	3.17	5.02	6.71	/	/	5,775
	38	0.59	1.15	2.31	3.51	4.61	5.35	6.28	6,544
750	25	1.41	2.72	5.12	7.18	9.56	/	/	3,589
	30	1.35	2.22	4.83	6.71	8.89	/	/	4,926
	25HD	1.36	2.24	4.84	6.69	8.96	/	/	4,844
	38	0.94	.81	3.39	5.13	6.32	7.74	/	5,456
900	25	2.42	4.73	8.83	12.42	/	/	/	3,216
	30	2.27	4.15	7.64	9.35	/	/	/	4,289
	25HD	2.29	4.14	7.67	/	/	/	/	4,172
	38	1.61	3.12	5.83	8.21	9.17	10.23	/	4,889
1200	25	4.23	6.29	11.76	16.52	/	/	/	2,431
	30	3.35	5.47	/	/	/	/	/	3,674
	25HD	3.49	5.48	/	/	/	/	/	3,504
	38	2.84	4.15	7.79	11.01	/	/	/	3,967

Uniform Load

25 x 100mm mesh



Span (mm)	Height (mm)	Load kg/m ²							Max Load (kg/m ²)
		150	350	500	750	1000	1500	2500	
300	25	/	0.28	0.37	0.51	0.63	0.73	1.04	26,350
	30	/	/	0.31	0.43	0.53	0.61	0.87	31,620
	25HD	/	/	/	0.26	0.53	0.79	1.32	32,940
	38	/	/	/	0.34	0.41	0.48	0.68	40,052
450	25	0.53	0.72	1.36	2.16	2.86	3.54	7.22	15,128
	30	0.44	0.61	1.13	1.80	2.38	2.95	6.02	18,154
	25HD	0.29	0.51	0.76	1.27	1.53	2.29	3.82	18,910
	38	0.35	0.47	0.89	1.42	1.88	2.33	4.75	22,995
600	25	0.73	0.92	1.86	2.46	3.68	5.54	9.22	12,688
	30	0.16	0.77	1.55	2.05	3.07	3.62	7.68	15,226
	25HD	0.89	1.27	2.03	3.30	4.32	6.35	/	15,860
	38	0.48	0.61	1.22	.62	2.42	3.64	6.07	19,286
750	25	1.65	2.86	3.71	5.63	8.32	/	/	10,150
	30	1.38	2.38	3.09	4.69	6.93	/	/	12,180
	25HD	1.87	3.06	4.57	7.12	9.41	/	/	12,688
	38	1.09	1.88	2.44	3.70	5.47	7.87	/	15,428
900	25	2.13	3.64	6.61	9.87	12.57	/	/	7,289
	30	1.78	3.03	5.51	8.23	10.48	/	/	8,747
	25HD	3.87	5.84	8.89	/	/	/	/	9,111
	38	1.40	2.39	4.35	6.49	8.27	12.16	/	11,079
1200	25	5.62	8.37	14.91	/	/	/	/	4,587
	30	4.71	6.98	12.43	/	/	/	/	5,504
	25HD	7.62	12.71	/	/	/	/	/	5,734
	38	3.72	5.51	9.81	13.47	/	/	/	6,972

Concentrated Point Load

25 x 100mm mesh



Span (mm)	Height (mm)	Load kg/m ²							
		150	350	500	750	1000	1500	2500	3000
300	25	0.29	0.69	0.99	1.50	2.13	2.89	4.74	/
	30	/	0.58	0.83	1.25	1.78	2.41	3.95	/
	25HD	/	0.52	0.74	1.13	1.60	2.17	3.56	/
	38	/	0.46	0.66	.01	1.43	1.94	3.18	/
450	25	0.47	1.10	1.43	2.25	3.20	4.33	/	/
	30	0.39	0.91	1.19	1.88	2.67	3.61	4.83	/
	25HD	0.35	0.82	1.07	1.69	2.40	3.25	4.39	/
	38	0.32	0.74	0.96	1.51	2.15	2.91	3.89	4.85
600	25	0.69	1.63	2.12	3.34	4.74	6.42	/	/
	30	0.58	1.35	1.77	2.78	3.95	5.35	/	/
	25HD	0.52	1.22	1.59	2.50	3.56	4.81	7.36	/
	38	0.46	1.09	1.42	2.24	3.18	4.31	5.82	/
750	25	1.32	3.08	3.97	6.28	9.22	/	/	/
	30	1.10	2.57	3.30	5.24	7.68	/	/	/
	25HD	0.99	2.31	2.97	4.71	6.92	9.34	/	/
	38	0.89	2.07	2.66	4.22	6.19	8.35	/	/
900	25	1.87	4.53	5.80	9.24	/	/	/	/
	30	1.56	3.78	4.83	7.70	10.27	/	/	/
	25HD	1.40	3.40	4.35	6.93	9.23	/	/	/
	38	1.25	3.04	3.89	6.20	8.27	/	/	/
1200	25	3.09	7.78	10.89	15.80	/	/	/	/
	30	2.58	6.49	9.07	13.17	/	/	/	/
	25HD	2.32	5.84	8.17	11.85	/	/	/	/
	38	2.08	5.22	7.31	10.60	13.25	/	/	/

Concentrated Line Load

Slot Mesh



Span (mm)	Type		Load kg/m of width							Max Load (kg/m)
	Height (mm)	Mesh (mm)	75	150	300	450	600	750	1500	
300	38	38 x 100	<0.25	0.25	0.59	0.75	1.02	1.32	2.53	11,882
	38	25 x 125	<0.25	0.33	0.61	0.89	1.16	1.42	2.46	11,796
	38	38 x 152	/	<0.25	0.25	0.52	0.63	.78	1.62	12,628
	50	25 x 50	/	/	/	/	/	<0.25	0.27	69,741
	28	60 x 100	0.39	0.54	1.08	1.38	1.86	2.4	4.62	6,507
	40	60 x 220	0.53	0.89	2.09	2.66	3.61	/	/	3,366
450	38	38 x 100	0.49	0.76	1.67	2.43	3.17	3.96	5.61	9,657
	38	25 x 125	0.33	0.56	0.97	1.32	1.65	1.98	3.35	9,737
	38	38 x 152	<0.25	0.25	0.78	1.12	1.55	1.79	.24	9,946
	50	25 x 50	/	/	/	/	/	0.26	0.54	48,574
	28	60 x 100	1.04	/1.62	3.04	4.43	/	/	/	5,288
	40	60 x 220	0.89	2.69	1.67	3.91	5.19	/	/	2,736
600	38	38 x 100	0.71	1.51	2.86	4.37	5.86	6.21	8.58	6,039
	38	25 x 125	0.54	0.79	1.32	1.81	2.31	2.82	5.11	6,109
	38	38 x 152	0.25	0.78	1.55	2.29	3.05	3.81	5.17	8,253
	50	25 x 50	/	/	0.27	0.39	0.48	0.55	1.29	40,530
	28	60 x 100	1.51	3.21	5.21	7.98	/	/	/	3,307
	40	60 x 220	0.76	4.36	6.13	8.92	/	/	/	1,711
750	38	38 x 100	1.18	2.02	6.62	6.45	7.48	8.68	/	5,176
	38	25 x 125	0.77	1.07	1.96	2.82	3.69	4.57	8.34	5,243
	38	38 x 152	0.76	1.28	2.81	4.07	5.34	6.62	8.68	7,104
	50	25 x 50	/	/	0.51	0.77	1.03	1.28	2.29	32,346
	28	60 x 100	2.5	4.29	7.82	/	/	/	/	2,834
	40	60 x 220	3.38	6.08	9.19	/	/	/	/	1,466
900	38	38 x 100	2.02	3.67	6.94	9.23	11.17	/	/	4,429
	38	25 x 125	1.09	2.08	2.91	4.63	5.56	6.48	12.09	4,435
	38	38 x 152	1.04	2.29	.32	6.61	8.64	10.92	/	6,146
	50	25 x 50	/	/	0.75	1.18	1.63	2.05	4.13	26,969
	28	60 x 100	4.19	6.68	9.22	/	/	/	/	2,452
	40	60 x 220	4.51	7.67	10.23	/	/	/	/	1,255
1200	38	38 x 100	3.55	4.69	9.12	12.06	/	/	/	3,816
	38	25 x 125	2.06	2.95	5.77	.56	/	/	/	3,834
	38	38 x 152	2.28	4.83	9.66	12.87	/	/	/	5,145
	50	25 x 50	/	/	1.46	2.09	2.74	3.35	6.37	23,095
	28	60 x 100	7.52	8.24	11.67	/	/	/	/	2,090
	40	60 x 220	6.55	11.69	/	/	/	/	/	1,081

Uniform Load



Slot Mesh

Span (mm)	Type		Load kg/m ²							Max Load (kg/m ²)
	Height (mm)	Mesh (mm)	150	350	500	750	1000	1500	2500	
300	38	38 x 100	/	/	0.34	0.50	0.62	0.72	1.03	26,701
	38	25 x 125	/	/	0.37	0.53	0.65	0.76	1.08	25,366
	38	38 x 152	/	0.37	0.56	0.79	0.98	1.14	1.62	16,911
	50	25 x 50	/	/	/	/	/	/	/	456,768
	28	60 x 100	0.28	0.59	0.78	1.08	1.33	1.54	2.19	11,456
	40	60 x 220	0.36	0.84	1.26	1.81	2.23	2.59	3.68	7,439
450	38	38 x 100	0.52	0.71	1.34	2.13	2.82	3.49	7.13	15,330
	38	25 x 125	0.55	0.75	1.41	2.24	2.97	3.68	7.5	14,563
	38	38 x 152	0.83	1.12	2.12	3.37	4.46	5.52	1.25	9,709
	50	25 x 50	/	/	/	/	/	/	/	212,280
	28	60 x 100	1.12	1.52	2.87	4.56	/	/	/	6,577
	40	60 x 220	1.88	2.55	4.82	7.65	/	/	/	4,271
600	38	38 x 100	0.72	0.91	1.84	2.43	3.63	5.47	9.10	12,857
	38	25 x 125	0.76	0.96	1.93	2.56	3.82	7.5	9.58	12,214
	38	38 x 152	1.14	1.43	2.90	3.83	5.73	8.63	/	8,143
	50	25 x 50	/	/	0.31	0.51	0.62	0.77	0.95	132,736
	28	60 x 100	1.54	1.94	3.92	5.19	7.76	/	/	5,516
	40	60 x 220	2.59	3.26	6.59	/	/	/	/	3,582
750	38	38 x 100	1.63	2.82	3.66	5.56	8.21	11.81	/	10,285
	38	25 x 125	1.71	2.97	3.85	8.5	8.64	12.43	/	9,771
	38	38 x 152	2.57	4.46	5.78	8.77	/	/	/	6,514
	50	25 x 50	/	0.74	1.02	1.53	1.63	1.78	2.02	84,912
	28	60 x 100	3.48	6.03	7.82	/	/	/	/	4,413
	40	60 x 220	5.84	10.13	/	/	/	/	/	2,865
900	38	38 x 100	2.10	3.59	6.52	9.74	12.40	/	/	7,386
	38	25 x 125	2.21	3.78	6.87	10.25	13.06	/	/	7,017
	38	38 x 152	3.32	5.67	10.30	/	/	/	/	4,678
	50	25 x 50	0.76	1.52	2.28	3.06	3.63	3.81	4.17	42,944
	28	60 x 100	4.49	7.68	13.94	/	/	/	/	3,169
	40	60 x 220	7.54	12.89	/	/	/	/	/	2,058
1200	38	38 x 100	5.58	8.26	14.71	/	/	/	/	4,678
	38	25 x 125	5.87	8.69	15.49	/	/	/	/	4,416
	38	38 x 152	8.80	13.04	/	/	/	/	/	2,944
	50	25 x 50	2.79	3.02	4.86	5.61	6.34	7.13	8.12	32,912
	28	60 x 100	11.92	17.65	/	/	/	/	/	1,994
	40	60 x 220	/	/	/	/	/	/	/	1,295

Concentrated Point Load

Slot Mesh



Span (mm)	Type		Load kg							
	Height (mm)	Mesh (mm)	150	350	500	750	1000	1500	2500	3000
300	38	38 x 100	0.27	0.68	0.98	1.48	2.10	2.85	4.68	/
	38	25 x 125	0.28	0.66	.95	1.44	2.04	2.76	4.53	/
	38	38 x 152	0.38	0.97	1.39	2.11	3.00	4.06	/	/
	50	25 x 50	/	/	/	0.38	0.54	0.73	1.20	1.45
	28	60 x 100	0.57	1.43	2.05	3.08	/	/	/	/
	40	60 x 220	0.87	2.20	3.16	/	/	/	/	/
450	38	38 x 100	0.46	1.08	1.41	2.22	3.16	4.27	/	/
	38	25 x 125	0.45	1.05	1.37	2.15	3.06	4.14	5.54	/
	38	38 x 152	0.66	1.54	2.01	3.17	4.50	/	/	/
	50	25 x 50	/	0.28	0.36	0.57	0.81	1.10	1.81	2.17
	28	60 x 100	0.98	2.28	2.97	4.34	/	/	/	/
	40	60 x 220	1.50	3.51	4.57	/	/	/	/	/
600	38	38 x 100	0.68	1.60	2.09	3.29	4.68	6.33	/	/
	38	25 x 125	0.66	1.55	2.03	3.19	4.53	6.14	/	/
	38	38 x 152	0.97	2.29	2.98	4.69	6.67	/	/	/
	50	25 x 50	/	0.41	0.54	0.85	1.20	1.63	2.68	3.21
	28	60 x 100	1.43	3.37	4.40	5.52	/	/	/	/
	40	60 x 220	2.20	5.20	6.77	/	/	/	/	/
750	38	38 x 100	1.30	3.04	3.91	6.20	9.10	/	/	/
	38	25 x 125	1.26	2.95	3.79	6.01	8.82	/	/	/
	38	38 x 152	1.86	4.34	5.57	8.83	/	/	/	/
	50	25 x 50	0.34	0.78	1.01	1.60	2.34	3.17	4.94	5.93
	28	60 x 100	2.74	6.40	7.69	/	/	/	/	/
	40	60 x 220	4.22	9.86	/	/	/	/	/	/
900	38	38 x 100	1.84	4.47	5.72	9.12	/	/	/	/
	38	25 x 125	1.79	4.33	5.55	8.84	11.78	/	/	/
	38	38 x 152	2.62	6.37	8.15	/	/	/	/	/
	50	25 x 50	0.47	1.15	1.47	2.35	3.48	5.06	6.83	8.21
	28	60 x 100	3.87	9.40	/	/	/	/	/	/
	40	60 x 220	5.97	14.48	/	/	/	/	/	/
1200	38	38 x 100	3.05	7.78	10.74	15.58	/	/	/	/
	38	25 x 125	2.96	7.44	10.41	15.11	/	/	/	/
	38	38 x 152	4.35	10.94	15.31	/	/	/	/	/
	50	25 x 50	0.79	1.98	2.77	4.01	5.35	7.77	10.49	12.59
	28	60 x 100	6.42	16.15	/	/	/	/	/	/
	40	60 x 220	9.89	24.87	/	/	/	/	/	/

Concentrated Line Load

Mini Mesh/ Micro Mesh



Span (mm)	Type		Load kg/m of width							Max Load (kg/m)	
	Height (mm)	Mesh (mm)	75	150	300	450	600	750	1500		
300	25	19 x 19/ 38 x 38	<0.25	0.26	0.47	0.71	1.05	1.41	2.95	10,916	
	38		<0.25	<0.25	0.36	0.45	0.58	0.69	1.41	19,373	
	30	20 x 20/ 40 x 40	<0.25	0.26	0.49	0.74	1.26	1.57	3.13	10,696	
	40		/	/	0.26	0.49	0.61	0.71	1.44	18,711	
	38		<0.25	<0.25	0.38	0.56	0.73	0.85	1.73	16,745	
	50		25 x 25/ 50 x 50	/	<0.25	0.28	0.43	0.58	0.66	1.33	23,877
	40		13 x 13/ 40 x 40	<0.25	<0.25	0.32	0.48	0.82	1.02	2.03	14,481
450	25	19 x 19/ 38 x 38	0.27	0.47	0.94	1.39	1.93	2.41	5.02	5,311	
	38		<0.25	0.42	0.82	1.21	1.65	2.08	4.24	14,688	
	30	20 x 20/ 40 x 40	0.26	0.48	0.96	1.46	1.91	2.49	5.12	5,206	
	40		/	0.43	0.83	1.24	1.68	2.13	4.36	13,631	
	38		26 x 26/ 52 x 52	<0.25	0.51	0.93	1.34	1.92	2.60	5.34	12,685
	50		25 x 25/ 50 x 50	<0.25	0.39	0.69	0.85	1.12	2.04	4.26	18,103
	40		13 x 13/ 40x40	<0.25	0.35	0.70	1.06	1.39	1.81	3.73	7,048
600	25	19 x 19/ 38 x 38	0.49	1.2	2.16	3.34	4.39	5.45	/	4,498	
	38		0.32	0.58	1.12	1.69	2.27	2.84	5.76	9867	
	30	20 x 20/ 40 x 40	0.47	1.17	2.07	3.22	4.29	5.33	9.41	4,289	
	40		0.34	0.61	1.16	1.71	2.26	3.06	6.21	9,135	
	38		26 x 26/ 52 x 52	.41	0.72	1.32	2.05	2.57	3.18	6.43	8,529
	50		25 x 25/ 50 x 50	0.32	.53	0.98	1.62	2.02	2.38	4.93	12,161
	40		13 x 13/ 40 x 40	0.34	0.85	1.51	2.34	3.12	3.88	6.85	5,807
750	25	19 x 19/ 38 x 38	1.2	2.45	4.52	6.81	10.06	/	/	3,493	
	38		0.56	1.02	1.94	2.98	3.88	5.02	10.87	8,227	
	30	20 x 20/ 40 x 40	1.14	2.31	4.34	6.58	9.99	/	/	3,158	
	40		0.59	1.07	2.11	3.05	3.83	4.96	10.83	7,492	
	38		26 x 26/ 52 x 52	0.58	1.21	2.14	3.19	4.21	5.47	10.96	7,114
	50		25 x 25/ 50 x 50	0.42	0.84	1.45	2.15	3.17	4.21	8.48	10,131
	40		13 x 13/ 40x40	.83	1.68	3.16	4.79	7.27	/	/	4,275
900	25	19 x 19/ 38x 38	1.68	3.63	7.09	10.54	/	/	/	2,907	
	38		0.77	1.59	3.31	5.16	6.75	8.29	14.58	6,568	
	30	20 x 20/ 40 x 40	1.66	3.48	6.89	10.32	/	/	/	2,686	
	40		0.83	1.63	3.31	5.12	6.82	8.74	/	6,093	
	38		26 x 26/ 52 x 52	0.84	1.89	3.82	4.89	5.83	6.95	14.08	5,701
	50		25 x 25/ 50 x 50	0.47	1.54	3.13	4.01	4.84	5.71	11.64	8,246
	40		13 x 13/ 40x40	1.21	2.53	5.02	7.51	8.64	/	/	3,636
1200	25	19 x 19/ 38x 38	3.31	7.21	13.06	/	/	/	/	1,424	
	38		2.11	.23	8.81	13.31	/	/	/	4,249	
	30	20 x 20/ 40 x 40	3.21	7.01	12.93	/	/	/	/	1,362	
	40		2.12	4.52	8.89	13.51	/	/	/	3,801	
	38		26 x 26/ 52 x 52	1.89	3.87	7.84	9.87	11.92	/	/	3,784
	50		25 x 25/ 50 x 50	1.54	3.14	6.39	8.03	9.68	12.21	/	6,289
	40		13 x 13/ 40x40	2.34	5.10	9.41	12.71	/	/	/	/

Uniform Load



Mini Mesh/ Micro Mesh

Span (mm)	Type		Load kg/m ²							Max Load (kg/m ²)	
	Height (mm)	Mesh (mm)	150	350	500	750	1000	1500	2500		
300	25	19 x 19/ 38 x 38	<0.25	0.32	0.42	0.63	0.82	1.23	2.05	56,530	
	38		<0.25	<0.25	0.28	0.41	0.54	0.81	1.35	85,930	
	30	20 x 20/ 40 x 40	<0.25	<0.25	<0.25	<0.25	<0.25	0.25	0.51	34,037	
	40		<0.25	<0.25	<0.25	<0.25	<0.25	<0.25	0.38	35,383	
	38		26 x 26/ 52 x 52	<0.25	<0.25	<0.25	<0.25	0.28	0.37	0.50	41,521
	50	25 x 25/ 50 x 50	<0.25	<0.25	<0.25	<0.25	<0.25	<0.25	<0.25	0.37	59,818
	40	13 x 13/ 40 x 40	/	/	/	0.31	0.42	0.61	0.97	46,081	
450	25	19 x 19/ 38 x 38	<0.25	0.47	0.63	0.94	0.23	1.85	3.08	37,690	
	38		<0.25	0.31	0.41	0.62	0.81	1.22	2.03	57,290	
	30	20 x 20/ 40 x 40	<0.25	0.31	0.50	0.75	0.98	1.47	2.19	22,343	
	40		<0.25	<0.25	0.37	0.56	0.73	1.11	1.64	29,790	
	38		26 x 26/ 52 x 52	<0.25	0.28	0.39	0.58	0.76	1.14	1.70	27,255
	50	25 x 25/ 50 x 50	<0.25	<0.25	0.28	0.42	0.55	0.84	1.24	37,297	
	40	13 x 13/ 40x40	/	/	0.36	0.54	0.71	1.07	1.60	30,249	
600	25	19 x 19/ 38 x 38	0.58	1.33	1.92	2.87	3.73	5.59	9.32	16,360	
	38		0.38	0.88	1.26	1.89	2.45	3.68	6.13	24,870	
	30	20 x 20/ 40 x 40	0.78	0.99	1.47	2.19	2.67	4.13	7.06	13,388	
	40		0.59	0.74	1.11	1.64	2.00	3.10	5.30	17,851	
	38		26 x 26/ 52 x 52	0.61	0.77	1.14	1.70	2.07	6.05	7.91	16,332
	50	25 x 25/ 50 x 50	0.45	0.56	0.84	1.24	1.52	4.42	5.78	22,348	
	40	13 x 13/ 40 x 40	0.57	0.72	1.07	1.60	1.94	3.01	5.14	18,125	
750	25	19 x 19/ 38 x 38	0.73	1.66	2.40	3.59	4.66	6.99	11.65	10,910	
	38		0.48	1.09	1.58	2.36	3.07	4.60	7.66	16,580	
	30	20 x 20/ 40 x 40	1.02	2.43	3.65	5.47	7.29	/	/	8,557	
	40		0.77	1.82	2.73	4.10	5.47	8.16	/	11,409	
	38		26 x 26/ 52 x 52	0.80	1.89	2.83	4.25	8.39	/	/	10,438
	50	25 x 25/ 50 x 50	0.58	1.38	2.07	3.10	6.13	8.71	/	14,284	
	40	13 x 13/ 40x40	0.75	1.77	2.65	3.98	5.31	7.17	/	11,584	
900	25	19 x 19/ 38x 38	2.89	7.01	9.23	/	/	/	/	4,770	
	38		1.90	4.61	6.07	9.03	/	/	/	7,250	
	30	20 x 20/ 40 x 40	2.05	4.38	6.80	10.21	/	/	/	5,939	
	40		1.54	3.29	5.10	7.5	10.08	/	/	7,919	
	38		26 x 26/ 52 x 52	1.59	3.40	5.28	7.93	10.52	/	/	7,245
	50	25 x 25/ 50 x 50	1.16	2.49	3.86	5.79	7.69	9.46	/	9,914	
	40	13 x 13/ 40x40	1.49	3.19	4.95	7.43	8.54	/	/	8,040	
1200	25	19 x 19/ 38x 38	3.85	9.35	12.31	/	/	/	/	3,600	
	38		2.53	6.15	8.10	12.09	/	/	/	5,470	
	30	20 x 20/ 40 x 40	5.66	7.89	11.27	/	/	/	/	3,499	
	40		4.24	5.92	8.45	12.37	/	/	/	4,665	
	38		26 x 26/ 52 x 52	4.39	6.13	8.75	11.82	/	/	/	4,268
	50	25 x 25/ 50 x 50	3.21	4.48	6.40	8.64	11.39	/	/	5,841	
	40	13 x 13/ 40x40	1.61	4.06	5.68	8.24	9.23	12.45	/	/	

Concentrated Point Load

Mini Mesh/ Micro Mesh



Span (mm)	Type		Load kg								
	Height (mm)	Mesh (mm)	150	350	500	750	1000	1500	2500	3000	
300	25		/	0.29	0.39	0.68	0.90	1.17	1.85	2.29	
	38	19 x 19/ 38 x 38	/	/	0.31	0.54	0.72	0.93	1.48	1.82	
	30	20 x 20/ 40 x 40	/	0.33	0.45	0.78	1.03	1.34	.12	2.62	
	40		/	.25	0.33	0.58	0.77	1.00	1.59	1.97	
		38	26 x 26/ 52 x 52	/	0.48	0.63	0.99	1.41	1.91	3.13	/
		50	25 x 25/ 50 x 50	/	0.34	0.45	0.70	1.00	1.36	2.22	2.67
		40	13 x 13/ 40 x 40	/	/	0.32	0.57	0.75	0.97	1.54	1.91
450	25	19 x 19/ 38 x 38	0.39	0.47	0.64	1.11	1.47	1.91	3.02	3.74	
	38	20 x 20/ 40 x 40	/	0.38	0.52	0.90	1.20	1.55	2.46	3.04	
	30		0.38	0.50	0.67	1.17	1.55	2.01	3.18	3.93	
	40	0.25	0.37	0.50	0.87	1.16	1.51	2.39	2.95		
		38	26 x 26/ 52 x 52	0.39	0.81	1.05	1.65	2.35	3.18	5.22	/
		50	25 x 25/ 50 x 50	0.25	0.51	0.67	1.06	1.50	2.03	3.34	4.01
		40	13 x 13/ 40x40	/	0.36	0.49	0.85	1.13	1.46	2.32	2.86
600	25	19 x 19/ 38 x 38	0.53	1.11	1.44	2.27	3.23	4.37	7.17	/	
	38	20 x 20/ 40 x 40	0.43	0.90	1.17	1.85	2.63	3.56	5.93	/	
	30		0.56	1.17	1.52	2.39	3.40	4.60	7.55	/	
	40	0.42	0.87	1.14	1.79	2.55	3.45	5.66	/		
		38	26 x 26/ 52 x 52	0.57	1.19	1.55	2.45	3.48	4.71	7.73	/
		50	25 x 25/ 50 x 50	0.36	0.76	0.99	1.57	2.22	3.01	4.94	5.93
		40	13 x 13/ 40 x 40	0.41	0.85	1.11	1.74	2.47	3.35	5.50	/
750	25	19 x 19/ 38 x 38	0.90	2.10	2.70	4.28	6.28	8.47	/	/	
	38	20 x 20/ 40 x 40	0.73	1.71	2.20	3.48	5.11	6.93	/	/	
	30		0.95	2.21	2.84	4.50	6.61	8.92	/	/	
	40	0.71	1.66	2.13	3.38	4.96	6.69	10.23	/		
		38	26 x 26/ 52 x 52	0.97	2.26	2.91	4.61	6.77	9.15	/	/
		50	25 x 25/ 50 x 50	0.62	1.45	1.86	2.95	4.33	5.85	9.12	/
		40	13 x 13/ 40x40	0.69	1.61	2.07	3.28	4.81	6.49	/	/
900	25	19 x 19/ 38x 38	1.27	3.09	3.95	6.29	9.33	/	/	/	
	38	20 x 20/ 40 x 40	1.03	2.51	3.22	5.12	7.59	10.30	/	/	
	30		1.34	3.25	4.16	6.62	9.82	/	/	/	
	40	1.00	2.44	3.12	4.97	7.36	9.94	/	/		
		38	26 x 26/ 52 x 52	1.37	3.33	4.26	6.78	10.05	/	/	/
		50	25 x 25/ 50 x 50	0.88	2.13	2.72	4.34	6.43	9.34	/	/
		40	13 x 13/ 40x40	0.97	2.36	3.03	4.82	7.15	9.65	/	/
1200	25	19 x 19/ 38x 38	2.11	5.30	7.41	10.76	13.45	/	/	/	
	38	20 x 20/ 40 x 40	1.72	4.31	6.03	8.76	12.87	/	/	/	
	30		2.22	5.58	7.80	11.32	/	/	/	/	
	40	1.66	4.18	5.85	8.49	11.32	/	/	/		
		38	26 x 26/ 52 x 52	2.27	5.71	7.99	11.55	15.47	/	/	/
		50	25 x 25/ 50 x 50	1.45	3.65	5.11	7.41	9.98	14.34	/	/
		40	13 x 13/ 40x40	1.61	4.06	5.68	8.24	9.23	12.45	/	/

Concentrated Line Load

HLC Mesh



Span (mm)	Type		Load kg/m of width							Max Load (kg/m)
	Height (mm)	Mesh (mm)	75	150	300	450	600	750	1500	
300	60	38 x 38	/	/	/	0.35	0.49	0.65	1.34	25,328
	50	25 x 25 / 50 x 50	/	<0.25	0.28	0.43	0.58	0.66	1.33	23,877
	25	25 x 100	<0.25	0.25	0.63	0.86	1.13	1.46	2.76	10,058
	50	25 x 50	/	/	/	/	/	<0.25	0.27	69,741
450	60	38 x 38	/	<0.25	0.45	0.67	0.89	1.14	2.35	19,445
	50	25 x 25 / 50 x 50	<0.25	0.39	0.69	0.85	1.12	2.04	4.26	18,103
	25	25 x 100	0.52	0.77	1.78	2.56	3.31	4.32	/	7,265
	50	25 x 50	/	/	/	/	/	0.26	0.54	48,574
600	60	38 x 38	<0.25	0.31	0.63	0.92	1.2	1.49	3.01	13,391
	50	25 x 25 / 50 x 50	0.32	0.53	0.98	1.62	2.02	2.38	4.93	12,161
	25	25 x 100	0.76	1.62	3.17	5.02	6.71	/	/	5,775
	50	25 x 50	/	/	0.27	0.39	0.48	0.55	1.29	40,530
750	60	38 x 38	0.35	0.71	1.38	2.11	2.81	3.49	7.03	11,331
	50	25 x 25 / 50 x 50	0.42	0.84	1.45	2.15	3.17	4.21	8.48	10,131
	25	25 x 100	1.36	2.24	4.84	6.69	8.96	/	/	4,844
	50	25 x 50	/	/	0.51	0.77	1.03	1.28	2.29	32,346
900	60	38 x 38	0.47	0.97	1.89	2.87	3.82	4.74	9.51	9,266
	50	25 x 25 / 50 x 50	0.47	1.54	3.13	4.01	4.84	5.71	11.64	8,246
	25	25 x 100	2.29	4.14	7.67	/	/	/	/	4,172
	50	25 x 50	/	/	0.75	1.18	1.63	2.05	4.13	26,969
1200	60	38 x 38	1.08	2.18	4.42	6.62	8.79	11.02	22.15	6,336
	50	25 x 25 / 50 x 50	1.54	3.14	6.39	8.03	9.68	12.21	/	6,289
	25	25 x 100	3.49	5.48	/	/	/	/	/	3,504
	50	25 x 50	/	/	1.46	2.09	2.74	3.35	6.37	23,095

Uniform Load



HLC Mesh

Span (mm)	Type		Load kg/m ²							Max Load (kg/m ²)
	Height (mm)	Mesh (mm)	150	350	500	750	1000	1500	2500	
300	60	38 x 38	/	/	/	/	/	/	/	/
	50	25 x 25 / 50 x 50	<0.25	<0.25	<0.25	<0.25	<0.25	<0.25	0.37	59,818
	25	25 x 100	/	/	/	0.26	0.53	0.79	1.32	32,940
	50	25 x 50	/	/	/	/	/	/	/	456,768
450	60	38 x 38	/	/	0.41	0.61	0.82	1.22	2.03	60,654
	50	25 x 25 / 50 x 50	<0.25	<0.25	0.28	0.42	0.55	0.84	1.24	37,297
	25	25 x 100	0.29	0.51	0.76	1.27	1.53	2.29	3.82	18,910
	50	25 x 50	/	/	/	/	/	/	/	212,280
600	60	38 x 38	0.33	0.41	0.62	0.92	1.12	2.86	7.14	36,344
	50	25 x 25 / 50 x 50	0.45	0.56	0.84	1.24	1.52	4.42	5.78	22,348
	25	25 x 100	0.89	1.27	2.03	3.30	4.32	6.35	/	15,860
	50	25 x 50	/	/	0.31	0.51	0.62	0.77	0.95	132,736
750	60	38 x 38	0.43	1.02	1.52	2.29	4.75	7.13	/	23,229
	50	25 x 25 / 50 x 50	0.58	1.38	2.07	3.10	6.13	8.71	/	14,284
	25	25 x 100	1.87	3.06	4.57	7.12	9.41	/	/	12,688
	50	25 x 50	/	0.74	1.02	1.53	1.63	1.78	2.02	84,912
900	60	38 x 38	0.68	1.83	2.84	4.27	6.41	9.62	/	16,122
	50	25 x 25 / 50 x 50	1.16	2.49	3.86	5.79	7.69	9.46	/	9,914
	25	25 x 100	3.87	5.84	8.89	/	/	/	/	9,111
	50	25 x 50	0.76	1.52	2.28	3.06	3.63	3.81	4.17	42,944
1200	60	38 x 38	2.37	3.30	4.71	7.07	9.43	14.15	/	9,499
	50	25 x 25 / 50 x 50	3.21	4.48	6.40	8.64	11.39	/	/	5,841
	25	25 x 100	7.62	12.71	/	/	/	/	/	5,734
	50	25 x 50	2.79	3.02	4.86	5.61	6.34	7.13	8.12	32,912

Uniform Load

HLC Mesh



Span (mm)	Type		Load kg							
	Height (mm)	Mesh (mm)	150	350	500	750	1000	1500	2500	3000
300	60	38 x 38	/	/	/	/	/	/	/	/
	50	25 x 25 / 50 x 50	/	0.34	0.45	0.70	1.00	1.36	2.22	2.67
	25	25 x 100	/	0.52	0.74	1.13	1.60	2.17	3.56	/
	50	25 x 50	/	/	/	0.38	0.54	0.73	1.20	1.45
450	60	38 x 38	/	/	/	0.37	0.49	0.64	1.01	1.25
	50	25 x 25 / 50 x 50	0.25	0.51	0.67	.06	1.50	2.03	3.34	4.01
	25	25 x 100	0.35	0.82	1.07	1.69	2.40	3.25	4.39	/
	50	25 x 50	/	0.28	.36	.57	0.81	1.10	1.81	2.17
600	60	38 x 38	/	0.37	0.48	0.76	1.08	1.46	2.43	2.92
	50	25 x 25 / 50 x 50	0.36	0.76	0.99	1.57	2.22	3.01	4.94	5.93
	25	25 x 100	0.52	1.22	1.59	2.50	3.56	4.81	7.36	/
	50	25 x 50	/	0.41	0.54	0.85	1.20	1.63	268	3.21
750	60	38 x 38	0.30	0.70	0.90	1.43	2.09	2.84	4.73	5.68
	50	25 x 25 / 50 x 50	0.62	1.45	1.86	2.95	4.33	5.85	9.12	/
	25	25 x 100	0.99	2.31	2.97	4.71	6.92	9.34	/	/
	50	25 x 50	0.34	0.78	1.01	1.60	2.34	3.17	4.94	5.93
900	60	38 x 38	0.42	1.03	1.32	2.10	3.11	4.22	7.03	8.44
	50	25 x 25 / 50 x 50	0.88	2.13	2.72	4.34	6.43	9.34	/	/
	25	25 x 100	1.40	3.40	4.35	6.93	9.23	/	/	/
	50	25 x 50	0.47	1.15	1.47	2.35	3.48	5.06	6.83	8.21
1200	60	38 x 38	0.70	1.77	2.47	3.59	5.27	7.16	11.39	/
	50	25 x 25 / 50 x 50	1.45	3.65	5.11	7.41	9.89	14.34	/	/
	25	25 x 100	2.32	5.84	8.17	11.85	/	/	/	/
	50	25 x 50	0.79	1.98	2.77	4.01	5.35	7.77	10.49	12.59



Pultruded Grating Load Tables

Appendix 2:

Load Table for Pultruded Grating

1. Deflection is in mm.
2. Walking loads, typically 65-80kg maximum are recommended for pedestrian traffic. Deflections for worker comfort are typically limited to the lesser of 10mm or **Clear Span** divided by 125; for a firmer feel, limit deflection to the lesser of 6.4mm or **Clear Span** divided by 200.
3. The allowable Loads in this table are for **Static Load Conditions** at ambient temperatures only. Allowable loads for impact or dynamic conditions should be a maximum of **One-Half** the values shown. Long term loads will result in added deflection due to the creep in the material and will also require higher safety factors to ensure acceptable performance. For applications at elevated temperatures, please consult with Grating FRP Australia. The design is further referenced to the ASCE Structural Plastics Design Manual.
4. All Gratings were tested in accordance with ANSI Standard; FRP Composites Grating Manual for Pultruded and Molded Grating and Stair Treads.

Concentrated Line Load



Type	Span (mm)	Load kg/m of width						Max Load (kg/m)
		300	450	750	1500	3000	5950	
I-4010	450	/	/	1.02	2.03	4.06	7.62	16,593
	600	/	/	2.54	4.57	8.89	17.53	12,959
	900	2.80	4.06	6.60	13.46	26.90	53.85	8,639
	1200	5.84	8.89	14.73	29.46	59.20	118.10	6,420
I-5010	450	/	/	1.02	2.03	4.06	7.62	13,808
	600	/	/	2.54	4.85	9.40	18.8	10,799
	900	2.54	4.06	6.86	13.46	27.20	54.1	7,194
	1200	7.37	10.9	18.28	36.58	73.20	146.0	5,362
I-6010	450	/	/	1.52	2.54	4.83	9.65	11,067
	600	/	/	3.05	5.59	11.2	22.10	8,639
	900	3.30	4.83	7.87	15.75	31.5	62.99	5,750
	1200	7.87	11.7	19.30	38.61	77.5	154.60	4,275
I-4015	450	/	0.25	0.51	0.76	1.52	2.79	26,215
	600	0.51	0.51	1.02	1.78	3.05	5.84	19,661
	900	1.02	1.27	2.29	4.32	8.38	16.76	12,705
	1200	2.03	2.79	4.57	9.40	19.1	37.85	9,086
I-5015	450	/	0.25	0.51	1.02	1.78	3.30	21,836
	600	0.51	0.51	1.02	1.78	3.56	6.86	16,385
	900	1.02	1.52	2.54	5.08	9.91	20.07	10,567
	1200	2.29	3.56	5.84	11.94	23.4	46.99	7,567
I-6015	450	/	0.25	0.51	0.76	2.03	3.81	17,472
	600	0.51	0.76	1.02	2.29	4.32	8.38	13,108
	900	1.27	2.03	3.30	6.10	12.50	25.15	8,460
	1200	2.79	4.32	7.11	14.22	28.50	56.90	6,047

Uniform Load



Type	Span (mm)	Load kg/m ²						Max Load (kg/m ²)
		1000	1900	3900	7000	9500	19500	
I-4010	450	1.25	0.76	1.27	2.29	3.05	6.10	72,325
	600	1.01	1.27	3.56	6.86	8.89	/	42,515
	900	4.57	8.38	16.26	/	/	/	18,863
	1200	14.48	/	/	/	/	/	10,507
I-5010	450	0.51	0.76	.27	2.54	3.302	6.60	60,499
	600	1.27	2.29	4.06	5.08	7.62	15.24	35,429
	900	4.83	8.89	17.27	/	/	/	15,638
	1200	16.51	/	/	/	/	/	8,796
I-6010	450	0.76	1.52	.79	3.81	7.37	/	48,380
	600	2.29	4.57	8.38	11.18	/	/	28,344
	900	10.92	/	/	/	/	/	12,559
	1200	/	/	/	/	/	/	6,988
I-4015	450	0.25	0.25	0.76	1.27	1.52	3.3	114,645
	600	0.51	0.76	1.52	2.79	3.81	7.62	64,506
	900	1.52	2.79	5.33	10.20	3.46	/	27,757
	1200	/	8.64	/	/	/	/	14,905
I-5015	450	0.25	0.51	.76	1.27	1.778	3.56	95,537
	600	0.51	0.76	1.52	3.05	4.06	8.13	53,755
	900	1.78	3.30	6.10	11.17	5.49	/	23,164
	1200	5.59	10.63	/	/	/	/	12,422
I-6015	450	0.25	0.25	0.76	1.27	1.78	3.56	76,430
	600	0.51	1.02	1.789	3.30	4.57	8.89	43,004
	900	2.29	4.06	7.87	14.70	/	/	18,570
	1200	6.6	12.95	/	/	/	/	9920

Concentrated Line Load



Type	Span (mm)	Load kg/m of width						Max Load (kg/m)
		300	450	750	1500	3000	5950	
T-120	450	0.254	0.508	0.762	1.27	2.286	4.826	6,181.5
	600	0.50	1.01	1.52	2.28	1.82	9.05	4,857.4
	900	1.52	3.04	7.82	7.87	/	/	3,233.3
	1200	3.556	7.366	10.92	/	/	/	2,428.7
T-2510	450	0.254	0.508	0.762	1.27	2.794	5.588	4,619
	600	0.50	1.01	1.77	2.79	5.58	11.43	3,471.7
	900	1.77	3.55	5.58	9.14	/	/	2,309.5
	1200	2.032	4.318	8.382	12.7	/	/	1,728.4
T-3310	450	0.584	0.86	1.448	2.87	5.74	/	103.9
	600	1.27	1.95	3.22	6.45	/	/	7,731
	900	4.01	5.99	10.06	/	/	/	5,024
	1200	8.992	/	/	/	/	/	3,620
T-3810	450	0.71	1.02	1.727	3.454	6.91	/	8,600
	600	0.54	2.34	3.88	7.74	/	/	6,427
	900	4.82	7.21	/	/	/	/	4,180
	1200	0.77	/	/	/	/	/	3,018
T-1215	450	<0.254	0.254	0.254	0.508	1.061	1.778	8,791
	600	<0.254	0.254	0.508	0.762	1.778	3.556	7,032.8
	900	0.508	1.016	1.524	2.794	5.334	10.66	4,678.6
	1200	1.27	2.54	3.55	6.09	12.19	/	3,515.4
T-2515	450	<0.254	0.254	0.254	0.508	1.016	2.286	7,539.4
	600	0.254	0.508	0.508	1.016	1.064	2.032	6,079.6
	900	0.508	1.27	1.778	3.048	6.35	12.4	4,023
	1200	1524	2.794	4.138	7.112	/	/	3009.8
T-3815	450	0.254	0.254	0.508	0.762	1.27	2.54	6,287.8
	600	0.254	0.508	0.762	1.27	2.296	4.826	5,021.3
	900	0.762	1.524	2.286	3.81	7.62	/	3,352.5
	1200	1.778	3.302	5.08	8.382	/	/	2,503.2
T-1810	450	0.4	0.67	1.07	2.0	2.67	3.34	5,900
	600	1.24	2.06	3.30	6.19	8.85	10.32	3,800
	900	2.76	4.59	7.35	13.78	/	/	2,300
	1200	5.16	8.60	13.76	/	/	/	2,200
T-3320	450	/	0.25	0.51	1.02	1.78	3.30	16,876
	600	0.51	0.76	1.27	2.29	4.57	9.40	7,492
	900	1.02	1.52	2.29	3.83	9.91	/	4,215
	1200	1.78	2.79	4.57	9.14	/	/	2,969
T-5020	450	0.25	0.51	0.76	1.27	2.29	4.57	12,657
	600	0.76	1.27	1.78	3.30	6.10	/	5,619
	900	1.52	2.29	3.56	6.60	/	/	3,161
	1200	2.54	3.81	6.35	12.45	/	/	2,022

Uniform Load



Type	Span (mm)	Load kg/m ²						Max Load (kg/m ²)
		450	950	1450	2400	4850	9500	
T-120	450	<0.254	0.254	0.762	1.016	2.286	4.572	14,932.8
	600	0.508	1.27	1.778	3.048	6.096	12.192	11,175.2
	900	2.794	5.842	8.89	/	/	/	7,076
	1200	9.144	/	/	/	/	/	3,562.4
T-2510	450	0.254	0.508	0.762	1.27	2.51	5.08	10,638.4
	600	0.762	1.524	2.032	3.556	7.112	/	8,003.2
	900	3.556	6.858	10.41	/	/	/	5,075.2
	1200	10.668	/	/	/	/	/	2,830.4
T-3310	450	0.56	1.069	2.134	4.039	5.23	/	45,076
	600	.63	3.226	6.542	12.12	/	/	25,363
	900	7.52	15.04	/	/	/	/	10,971
	1200	/	/	/	/	/	/	5,938
T-3810	450	0.66	1.295	2.616	5.004	6.53	/	37,624
	600	1.96	3.886	7.772	/	/	/	21,087
	900	9.02	/	/	/	/	/	9,158
	1200	/	/	/	/	/	/	4,940
T-1215	450	<0.254	0.254	0.254	0.508	1.106	1.778	19,227.2
	600	0.254	0.508	0.762	1.106	2.286	4.318	14,396
	900	1.016	2.032	3.048	5.08	0.16	/	9,613.6
	1200	3.048	6.096	9.144	/	/	/	5,758.4
T-2515	450	<0.254	0.254	0.254	0.508	1.016	2.032	10,638.4
	600	0.254	0.508	0.762	1.27	2.54	5.08	12,346.4
	900	1.27	2.286	3.556	5.842	11.68	/	8,247.2
	1200	3.556	7.112	10.66	/	/	/	4,928.8
T-3815	450	<0.254	0.254	0.254	0.508	1.27	2.54	13,712.8
	600	0.254	0.508	1.016	1.524	3.048	6.096	10,296.8
	900	1.524	2.794	4.318	7.112	/	/	6,880.8
	1200	4.318	8.382	12.70	/	/	/	4,099.3
T-1810	450	0.10	0.17	0.27	0.50	0.67	0.83	29,600
	600	0.46	0.77	1.24	2.32	3.10	3.87	12,700
	900	1.38	2.30	3.67	6.89	9.18	11.48	7,300
	1200	3.22	5.37	8.60	/	/	/	4,600
T-3320	450	0.25	0.51	0.76	1.52	2.03	4.06	55,368
	600	0.76	1.52	3.05	5.59	737	14.99	36,895
	900	2.29	4.57	9.40	/	/	/	27,659
	1200	5.08	9.91	/	/	/	/	22,137
T-5020	450	0.51	0.76	1.27	2.29	3.05	6.35	41,526
	600	1.02	2.03	3.81	6.86	9.40	/	27,671
	900	3.30	6.35	12.45	/	/	/	20,744
	1200	6.86	13.46	/	/	/	/	16,602

Concentrated Line Load

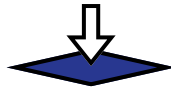

Type	Span (mm)	Load kg/m of width								
		150	300	450	750	1500	3000	4500	6000	7500
HL-4020	600	0.03	0.06	0.08	0.15	0.30	0.59	0.90	1.19	1.49
	750	0.05	0.10	0.17	0.27	0.54	1.08	1.63	2.19	2.73
	900	0.08	0.18	0.27	0.45	0.91	1.83	2.73	3.65	4.57
	1200	0.22	0.42	0.77	1.07	2.14	4.28	6.43	8.57	10.72
HL-5020	600	0.04	0.08	0.10	0.18	0.36	0.71	1.07	1.42	1.78
	750	0.06	0.12	0.20	0.32	0.65	1.30	1.95	2.62	3.27
	900	0.10	0.22	0.32	0.54	1.09	2.19	3.27	4.36	5.46
	1200	0.26	0.508	0.77	1.28	2.56	5.12	7.68	10.24	12.80
HL-6020	600	0.05	0.10	0.12	0.22	0.45	0.88	1.34	1.77	2.23
	750	0.07	0.15	0.25	0.40	0.81	1.62	2.43	3.27	4.08
	900	0.12	0.27	0.40	0.68	1.37	2.74	4.08	5.46	6.83
	1200	0.33	0.635	0.96	1.60	3.20	6.40	9.60	12.8	16.00
HI-4710	600	0.25	0.76	1.01	1.77	3.81	7.36	11.17	/	/
	750	0.76	1.52	2.28	3.55	7.36	/	/	/	/
	900	1.27	2.54	3.81	6.35	2.70	/	/	/	/
	1200	3.048	6.096	8.89	/	/	/	/	/	/
HI-4715	600	/	/	0.25	0.50	1.01	1.77	2.79	3.55	4.57
	750	/	0.25	0.50	0.76	1.77	3.55	5.33	6.85	8.63
	900	0.25	0.50	1.01	1.52	3.04	6.09	9.14	12.19	/
	1200	0.762	1.524	2.032	3.556	7.112	/	/	/	/
HI-4720	600	/	/	/	/	0.50	0.76	1.27	1.77	2.28
	750	/	/	/	0.50	0.76	1.77	2.54	3.30	4.06
	900	/	0.25	0.50	0.76	1.27	2.79	4.06	5.58	6.85
	1200	0.254	0.762	1.016	1.524	3.032	6.604	9.652	/	/
HI-4725	600	/	/	/	/	/	0.50	0.76	1.01	1.27
	750	/	/	/	/	0.50	1.01	1.27	1.70	2.28
	900	/	/	/	0.25	0.76	1.52	2.28	3.04	3.81
	1200	/	0.254	0.508	0.762	1.778	3.302	5.08	6.604	8.382
HI-4730	600	/	/	/	/	/	0.25	0.50	0.50	0.76
	750	/	/	/	/	0.25	0.50	0.76	1.01	1.52
	900	/	/	/	/	0.50	1.01	1.52	1.77	2.28
	1200	/	/	0.254	0.508	1.016	2.032	3.048	4.064	5.08

Uniform Load



Type	Span (mm)	Load kg/m ²								
		450	950	1450	2450	4850	9800	14500	19500	24400
HL-4020	600	0.034	0.068	0.119	0.187	0.374	0.748	1.123	1.497	1.854
	750	0.085	0.170	0.255	0.425	0.850	1.701	2.569	3.420	4.271
	900	0.170	0.340	0.510	0.850	1.718	3.043	5.139	6.858	8.577
	1200	0.544	1.072	1.061	2.688	5.360	0.72	/	/	/
HL-5020	600	0.040	0.081	0.142	0.223	0.447	0.894	1.341	1.788	2.214
	750	0.101	0.203	0.304	0.508	1.016	2.033	3.068	4.084	5.10
	900	0.203	0.406	0.609	1.016	2.523	4.104	6.136	8.188	10.241
	1200	0.650	1.280	1.930	3.210	6.400	12.80	/	/	/
HL-6020	600	0.050	0.101	0.177	0.279	0.558	1.117	1.676	2.235	2.768
	750	0.127	0.254	0.381	0.635	1.27	2.55	3.853	5.105	6.375
	900	0.254	0.508	0.762	1.27	2.654	5.130	7.670	10.236	12.801
	1200	0.812	1.600	2.413	4.013	8.001	16.00	/	/	/
HI-4710	600	0.508	1.016	1.524	1.778	2.286	2.794	3.302	3.81	4.318
	750	1.016	2.286	3.302	4.572	5.588	6.858	7.874	9.144	10.16
	900	2.286	4.826	7.12	9.398	11.68	/	/	/	/
	1200	7.366	/	/	/	/	/	/	/	/
HI-4715	600	/	/	0.254	0.508	0.508	0.762	0.762	1.016	1.016
	750	0.254	0.508	0.762	1.016	1.27	1.524	2.032	2.286	2.54
	900	0.508	1.016	1.778	2.286	2.794	3.302	4.064	4.572	5.08
	1200	1.778	3.556	5.334	7.112	8.89	10.66	12.44	/	/
HI-4720	600	/	/	/	/	0.254	0.254	0.508	0.508	0.508
	750	/	0.254	0.508	0.508	0.762	0.762	1.016	1.016	1.27
	900	0.254	0.508	0.762	.016	1.27	1.524	1.778	2.032	2.286
	1200	0.762	1.524	2.54	3.302	4.064	4.826	5.588	6.604	7.366
HI-4725	600	/	/	/	/	/	/	/	0.254	0.254
	750	/	/	/	0.254	0.254	0.508	0.508	0.508	0.762
	900	/	0.254	0.508	0.508	0.762	0.762	1.016	1.016	1.27
	1200	1.524	2.54	3.302	.778	2.032	2.54	3.048	3.302	0.03
HI-4730	600	/	/	/	/	/	/	/	/	/
	750	/	/	/	/	/	0.254	0.254	0.254	0.508
	900	/	/	0.254	0.254	0.508	0.508	0.508	0.762	0.762
	1200	/	0.508	0.762	1.016	1.27	1.524	1.778	2.032	2.286



Contact us for further enquiries



gratingfrpaustralia.com.au



WA, NT & SA
(08) 9584 2500



wa-sales@gratingfrpaustralia.com.au



NSW, QLD, VIC, TAS & ACT
(02) 4244 1008



nsw-sales@gratingfrpaustralia.com.au