



OUTDOOR KITCHENS & GRILLS

2024 GUIDE





SIGNATURE KITCHENS

Pre-Designed, Ready to Install

Signature Kitchens allow you to construct the perfect outdoor kitchen in days vs. weeks. Each kitchen has been pre-designed to fit a variety of size and style configurations and ship complete with all necessary cabinets, bolts and end-caps. Finalize your outdoor design by selecting a stone veneer from a large variety of color options and the appliances and countertop material of your choice. Each Signature Kitchen comes complete with all the necessary cabinets, bolts, and end caps.

METROPOLITAN OUTDOOR KITCHEN

The Metropolitan Signature Kitchen is an 12' linear kitchen, designed to save space compared to traditional L-shaped kitchens, yet provides ample counter space for preparation of an elegant night dining alfresco.



INCLUDES:

- (1) 36" Straight Cabinet
- (1) 48" Straight Cabinet
- (1) 60" Straight Cabinet
- (2) Cabinet End Caps
- (2) Fastener Sets
- (2) Vents

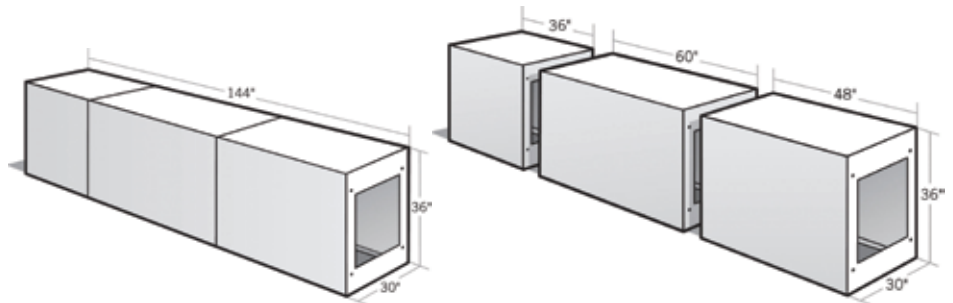

PARKVIEW OUTDOOR KITCHEN

The Parkview Signature Kitchen is a 9.5'x 6.5' L-shaped kitchen. The simple configuration and manageable size allows for the perfect entertaining center in a variety of outdoor settings.

INCLUDES:

- (1) 24" Straight Cabinet
- (1) 48" Straight Cabinet
- (1) 60" Straight Cabinet
- (1) 90° Corner Cabinet
- (2) Cabinet End Caps
- (3) Fastener Sets
- (2) Vents

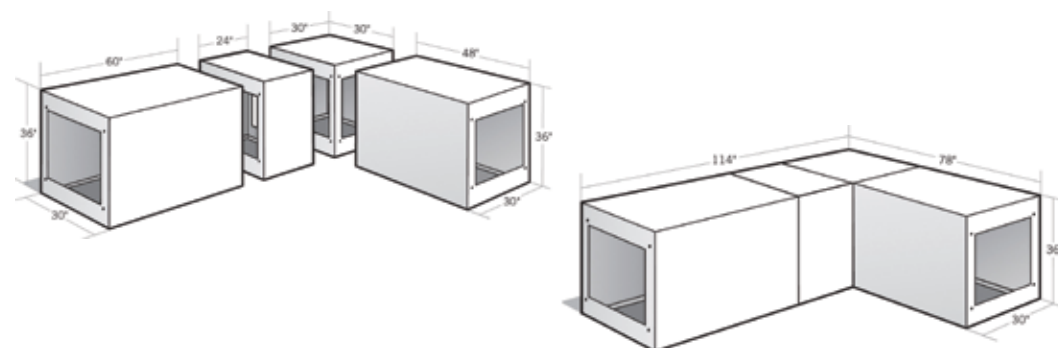



ARTFORM MODULAR PANELS

This revolutionary system utilizes a large-format modular panel system to create infinite design possibilities with ease. High-strength concrete is mechanically fastened with stainless steel hardware that creates little to no mess or disruption. Panels are sized in modular shapes to quickly and efficiently construct outdoor kitchens, seating, planters, fire features, and more!

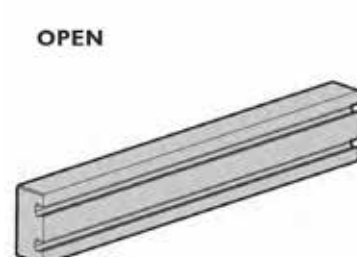
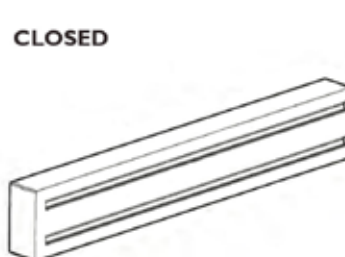
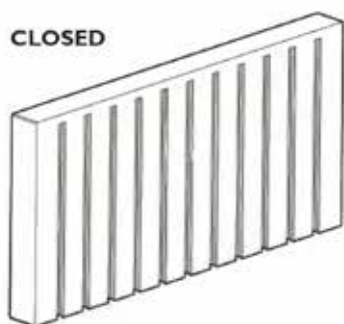



BUILDING BLOCKS

Building Block products quickly assemble into a virtually limitless combination of configurations. Each piece is made of glass-fiber reinforced concrete (GFRC) which can be installed on any solid flooring surface without concrete footings or rebar. Eliminated is construction waste and additional time associated with traditional masonry block installations. Building Block products can be assembled in just hours; even cut-outs for custom features such as barbecues, sinks, drawers, and burners can be done on-site.

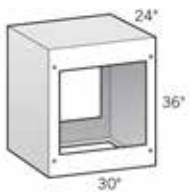

24" Cabinet

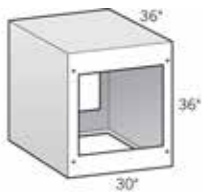

36" Cabinet

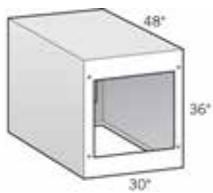

48" Cabinet



60" Cabinet

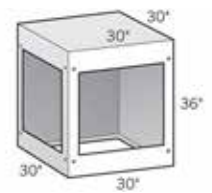

90° Corner Cabinet

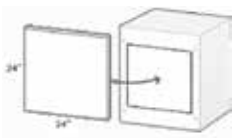

Cabinet End Cap 24"x24"



Column with End Cap



Vent

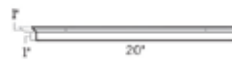

Appliance Bracket Set



Fastener Set

OUTDOOR LUXURY IN 5 EASY STEPS

1

Pre-Planning & Design

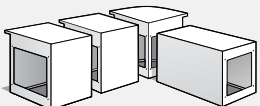

2

Install Cabinets

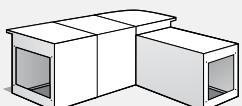

3

Cut Appliance Openings

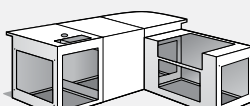

4

Install Appliances & Countertop

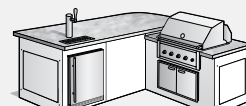

5

Install Stone Veneer





OUTDOOR GRILLS

Endless Enjoyment

With the combination of convenience and a sophisticated sleek look, grills are the hub of outdoor entertainment. And with a wide array of accessories and features like warming drawers, extra burners, rotisseries, storage, refrigeration, and more, you'll have all the ingredients you need for dining alfresco.



Blaze gas grills are an affordable commercial-style grill that feature precision cut, 304 stainless steel components that bring the promise of lasting durability to your outdoor BBQ. They have a lifetime warranty that warrants against any defects in the manufacturing and workmanship of the main burners, cooking grids, body, flame tamers, heat zone separators, warming rack, and control valves.

GENERAL FEATURES & SPECIFICATIONS:

- Commercial Quality 304 Stainless Steel Burners
- Burner BTU: 14,000
- Rear Rotisserie Burner: 10,000
- Heavy 8mm Stainless Steel Cooking Rods
- Push and Turn Flame-Thrower Primary Ignition System
- Flash Tube Ignition and Crossover Provide an Alternate Ignition Option
- Removable Warming Rack
- Heat Zone Separators Provide Individual Temperature Zones
- Flame Stabilizing Grids That Minimize Flare-ups
- Full-width Drip Tray for Quick Clean Up
- Double-lined Grill Hood
- Lifetime Warranty
- Fuel: Natural Gas or Propane

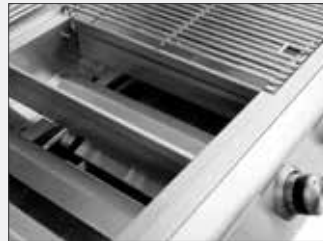

ACCESSORIES



Single Side Burner



Griddle



Outdoor Refrigerator 24"



Double Drawer



Triple Drawers 16"



Double Door 32"



Cart



Trash/LP Tank Drawer

BLAZE 32" LTE 4-Burner with Rear Burner and Built-In Lighting System



General Specifications:

- (4) 304 Stainless Steel Burners
- Total Burner BTU: 56,000
- Rear Rotisserie Burner: 10,000
- Total cooking Space: 740 sq in
- Cooking Grid Dimensions: 29.5" x 17.875"
- Fuel: Natural Gas or Propane
- Illuminated Control Knobs and Interior Lights
- Double-Lined Grill Hood
- Cut-Out Dimensions: 8.5"H x 30.625"W x 21.25"D

BLAZE 44" PRO 4-Burner with Rear Rotisserie



General Specifications:

- (4) 304 Stainless Steel Burners
- Total Burner BTU: 72,000
- Rear Rotisserie Burner: 10,000
- Total cooking Space: 794 sq in
- Heat Zone Dividers
- Fuel: Natural Gas or Propane
- Illuminated Control Knobs and Interior Lights
- Double-Lined Grill Hood
- Cut-Out Dimensions: 10.5"H x 42.5"W x 23.625"D

BLAZE 25" PRELUDE 3-Burner



General Specifications:

- (3) 304 Stainless Steel Burners
- Total Burner BTU: 42,000
- Heavy 8mm Stainless Steel Cooking Rods
- Total cooking Space: 558 sq in
- Heat Zone Separators
- Fuel: Natural Gas or Propane
- Flame Stabilizing Grids
- Double-Lined Grill Hood
- Cut-Out Dimensions: 8.5"H x 23.25"W x 21.25"D



Every Delta Heat grill is a distinct blend of modern design and classic elegance, making them a perfect choice for both traditional and contemporary architecture. Each grill combines direct heat from specifically placed ports and channels with radiant heat from the unique ceramic briquette grates, allowing your grill to reach higher temperatures and distribute heat evenly - ridding your grill of hot and cold spots.

GENERAL FEATURES:

Ceramic Radiant Grilling System

Unique and distinctive ceramic briquette trays above the burners provide radiant heating that's usually only found in charcoal grilling. This feature disperses heat evenly across your grill surface.

18-Gauge U-Burners

Heavy duty stainless steel U-shaped burners ensure a long-lasting, quality burner that can produce an immense amount of heat.

Interior Halogen Lighting

Interior mounted halogen lamps provide high quality and durable lighting for grilling at night.

Double Lined Hood

Thick, double-lined stainless steel hood ensures high quality heat retention when the lid is closed, while also ensuring the outside will not be hot to the touch - for added safety.

Analog Temperature Gauge

Accurate thermometer gauge embedded into the hood's exterior allows proper control over your grilling temperature.

Electronic Ignition

High quality 9-volt electronic ignition ensures startup will be quick and easy, every time.

Mirror Polished Accents

Precise polished accenting distinguishes Delta Heat grills as a quality product, with unmatched aesthetic appeal.

Infrared Rotisserie Burner

An optional infrared rotisserie burner with included rotisserie allows restaurant quality rotisserie cooking.



18-Gauge U-Burners



Ceramic Radiant Grilling System



Infrared Sear Zone



Warming Rack



Infrared Rotisserie Burner



Interior Halogen Lighting



LED Control Panel



Analog Temperature Gauge

DELTA HEAT 32" with Rotisserie



General Specifications:

- Built in the USA
- (3) 25,000 BTU Stainless Steel Heavy Walled Burners
- Primary Cooking Surface: 525 sq in
- Warming Rack Surface: 174 sq in
- Total Cooking Surface: 699 sq in
- 18 Gauge 304 Stainless Steel U-burners
- Cutout Dimensions: 9.5"H x 19.75"D x 30.5"W
- Cooking Grid Dimensions: 30" x 17.5"

DELTA HEAT 38" with Rotisserie



General Specifications:

- Built in the USA
- (3) 25,000 BTU Stainless Steel Heavy Walled Burners
- Primary Cooking Surface: 625 sq in
- Warming Rack Surface: 210 sq in
- Total Cooking Surface: 835 sq in
- 18 Gauge 304 Stainless Steel U-burners
- Cutout Dimensions: 9.5"H x 19.75"D x 36.5"W
- Cooking Grid Dimensions: 36" x 17.5"

ACCESSORIES



Double Slide-In Side Burner



Double Access Door 32"



Drop In Sink



Triple Drawers 13"



Drop In Cooler



Paper Towel Holder



Single Side Burner



Base Cart



Twin Eagles creates sleek, luxurious, and meticulously engineered grills, as beautiful as they are high performance. They embrace the very highest standards in design and manufacturing. All of their products are made in the USA by the finest craftspeople in the industry. Grilling performance and culinary perfection all come together in a gorgeous grill machine that features an innovatively engineered five-component system, designed for the ultimate grilling synergy.

GENERAL FEATURES:

The Sear Zone sears foods faster with 25,000 BTUs of direct, intense infrared heat to seal in natural juices, for moister, more flavorful foods.

Exclusive Control Illumination features a highly visible graduated line that glows indigo blue. A control knob indicator notch illuminates to give a precise control knob setting.

The Sealed Smoker Box holds soaked hickory, mesquite, or your favorite woodchips for all you flavor mavens who crave a subtle smoky taste.

The Grill Hood Assist System makes it easy for you to open and close the hood by reducing the weight load with hidden heavy-duty extension springs.

Rotisserie Rod Storage, conveniently located in the grill's drip tray handle for easy access.

The Concealed Heavy-Duty Rotisserie System features a fully integrated motor with 100 lbs turning capacity. A unique chain-driven design provides consistent and uniform rotation.

Hot Surface Ignition allows you to easily light the gas burners and rear rotisserie burner with their reliable electric hot surface igniters, operated simply by pushing in the burner or rotisserie control knob.

25,000 BTU, 14 Gauge, 304 Stainless Steel Burners & Zone Dividers Each high-performance burner is contained to control heat independently from one grilling area to another.

Hexagonal Grates made of 3/8" stainless steel retain more heat, enabling greater heat contact with food for even cooking. The flat grate surface also generates dark, deep, restaurant-style sear marks.



Sear Zone



Control Knob Illumination



Heavy-Duty Rotisserie System



Hexagonal Grates

TWIN EAGLES 36" with Rotisserie and Sear Zone

Features & Specifications:



- 25,000 BTU burners
- 14 Gauge 304 Stainless Steel Burners
- High Quality Ceramic Briquettes
- Hexagonal Grates for Maximum Food-To-Surface Contact
- Zone Dividers to Regulate Different Temperatures
- Reliable Hot Surface Ignition
- Easy-to-open Hood Assist System
- Interior Lights with Hood Activated Light Switch
- Exclusive Control Illumination Provides a Precise Control Knob Setting
- Extra Large 3-Position Warming and Cooking Rack
- Large Capacity Smoker Box
- Sear Zone with 25,000 BTUs of Direct, Intense Infrared Heat
- Concealed Heavy-Duty Rotisserie System with Fully Integrated Motor and 100lbs Turning Capacity

ACCESSORIES



Drop-in Cooler



Trash Drawer



Warming Drawer/Storage 42"



Double Burner NG



Since 1961, our reputation has been built upon integrity, professionalism, and a continued commitment to provide great service and products to our customers that's just the way we like to do things.

 **VALLEY
CITY SUPPLY**

ADDRESS: 1323 W River Road, Valley City, OH 44280

PHONE: 330.483.3400 **WEB:** ValleyCitySupply.com