

# BLAST MACHINES

## NBSC-200 - 200 LITERS

### INSTRUCTION MANUAL

This manual provides instructions for setting up and maintaining the Model NBSC-200 pressure type blast machine. Before using this equipment, it is essential to ensure that the individuals who operate and maintain the machine have read, understood, and followed all the instructions provided in this manual. It is recommended to store this manual in a secure location for future use, maintenance, troubleshooting, and ordering of spare parts.

SPECIFICATIONS	
ITEM NUMBER	20019404 (WITH FSV) & 20019411 (WITH MICROVALVE)
CAPACITY	200 LITERS
MAX. SYSTEM PRESSURE	12 BAR
MIN. SYSTEM PRESSURE	5 BAR
MAX. COMPRESSED AIR TEMPERATURE	50 °C
MIN. COMPRESSED AIR TEMPERATURE	5 °C
MAX. AMBIENT TEMPERATURE	50 °C
MIN. AMBIENT TEMPERATURE	5 °C
DIMENSIONS ((Ø X H)	615 X 1423 MM
WEIGHT	161 KG

# BLAST MACHINES

## TABLE OF CONTENTS

### INDEX

<b>SAFETY GUIDELINES</b>	<b>3</b>	<b>INSTALLATION GUIDELINES RCV-125</b>	<b>9</b>
<b>SET-UP GUIDE</b>	<b>4</b>	INSTALLATION STEPS	9
SET UP	4	ON-SITE INSTALLATION	9
OPERATION	4	<b>REMOTE CONTROL SYSTEM OPERATION</b>	<b>10</b>
SHUT-DOWN	4	START BLASTING	10
<b>MAINTENANCE &amp; TROUBLESHOOTING</b>	<b>5</b>	OPERATION	10
POP-UP VALVE REPLACEMENT	5	<b>RCV-125 MAINTENANCE GUIDELINES</b>	<b>11</b>
POP-UP O-RING REPLACEMENT	5	VALVE DISASSEMBLY STEPS	11
OBSTRUCTIONS	5	VALVE ASSEMBLY	11
ABRASIVE SURGE	5	INSPECTIONS	11
REMOVAL OF MOIST ABRASIVES	5	<b>PROBLEM-SOLVING RCV-125</b>	<b>12</b>
<b>DRAWINGS &amp; PARTS LIST</b>	<b>6</b>	INTRODUCTION	12
BLAST MACHINE WITH FSV	6	COMMON KNOWN ISSUES	12
BLAST MACHINE WITH MICRO VALVE	7	<b>DRAWING &amp; PARTS LIST RCV-125</b>	<b>13</b>
<b>REMOTE CONTROL SYSTEM RCV-125</b>	<b>8</b>	<b>DRAWING &amp; PARTS LIST DMH-125</b>	<b>14</b>
DESCRIPTION RCV-125	8	<b>AIR REQUIREMENT TABLE</b>	<b>15</b>
DEADMAN HANDLE	8	<b>WARRANTY</b>	<b>16</b>
SHUT-DOWN	8		
TRUSTWORTHINESS OF THE SYSTEM	8		

# BLAST MACHINES

## SAFETY GUIDELINES



HAND PROTECTION



EAR PROTECTION

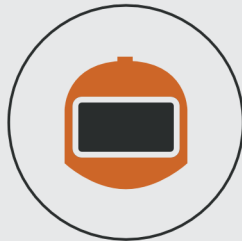

FACE PROTECTION

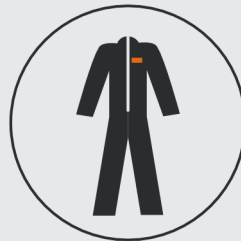

BODY PROTECTION

### ENSURE YOUR SAFETY AND THE SAFETY OF OTHERS

1. It is essential to use protective equipment while working, such as clothing that is resistant to abrasion, safety shoes, leather gloves, ear protection, and a CE-approved air-fed helmet. The air supply for the helmet must come from a breathing air compressor or a helmet air filter.
2. Take care to avoid possible silicosis hazards and minimize dust exposure.
3. Avoid using damaged or worn equipment for blasting.
4. Always point the nozzle at the specific area that needs cleaning.
5. Use only dry and well-screened abrasives that are intended specifically for blasting.
6. Keep unprotected workers out of the blast area at all times.
7. Before blasting, ensure that:
  - Fittings and hoses are in good condition.
  - Couplings are safety-wired together.
  - Helmet filters and air supply are functioning correctly.
  - The pop-up valve is correctly aligned.
  - Remote controls are tested.
  - The blasting machine is adequately grounded.
8. Do not weld on the blast machine as this will void its approval.
9. Do not use substitute Novablast parts or modified equipment in any way.

# BLAST MACHINES

## SET-UP GUIDE

### SET UP

To set up for manual controlled blasting (without the use of a remote control system), follow these steps:

1. Ensure that the compressor is positioned upwind from the blasting area. Start the compressor and bring it up to operating pressure and temperature before beginning the blast cleaning operation.
2. Open the bleed-off and choke valves (handles in parallel position with piping).
3. Close the air inlet valve at the abrasive valve.
  - Closed sand valve: position the handle at either extreme side of the center of the valve.
  - Closed grit valve: turn the handle fully clockwise.
4. Connect the compressed air line to the air inlet valve (for optimal blast cleaning performance, use a ¾" ID air line or larger).
5. Connect the blast hose quick connect coupling to the machine quick coupling. Check the condition and proper placement of the rubber coupling gaskets.
6. Fill the concave head of the machine with abrasive. The abrasive will pass through the filling port and into the machine.
7. Put on all necessary protective clothing.

### OPERATION

To perform blast cleaning, the operator should follow these steps:

1. Apply pressure to the air line of the blast machine.
2. Close the bleed-off valve.
3. When the blasting operator signals that they are ready, open the air inlet valve. This will cause the pop-up valve to seal the filling port and pressurize the blast machine, with only air coming out of the nozzle.
4. Adjust the abrasive valve for the proper air/abrasive mixture. As a general rule, use as little abrasive as possible. The abrasive stream coming out of the nozzle should hardly discolor the air when viewed against any light source.
5. To stop blasting, close the air inlet valve and quickly open the bleed-off valve.

### SHUT-DOWN

To shut down the blast machine at the end of the day, follow these steps:

1. Remove the nozzle and empty all abrasive from the machine into a suitable waste container using the blast hose.
2. Close the choke valve and fully open the handle of the abrasive valve.
3. Open the air inlet valve to put pressure into the machine.
4. Cover the blast machine if it will be left out at the site to prevent any moisture from affecting the abrasive when blasting is resumed.

# BLAST MACHINES

## MAINTENANCE & TROUBLESHOOTING

### MAINTENANCE GUIDE

#### POP-UP VALVE REPLACEMENT

Instructions for replacing the pop-up valve:

1. Remove the inspection door assembly to access the pop-up valve.
2. Turn the pop-up guide counterclockwise to unscrew it.
3. Remove both the pop-up valve and guide from the blast machine.
4. Insert the new pop-up valve into the valve guide and install them inside the machine.
5. It is recommended to also replace the inspection door gasket at this time.
6. Remember to tighten the inspection door assembly back onto the machine.

#### POP-UP O-RING REPLACEMENT

1. Place your fingers between the Pop-up O-ring and the retainer and carefully remove the old O-ring. If needed, use a screwdriver.
2. Insert the new Pop-up O-ring through the filling port and fit it into the retainer.
3. Pull up on the O-ring to position it properly.

**To minimize downtime, it is recommended to keep the O-ring on hand and readily available.**  
(O-Ring item number: 20188000)



### TROUBLESHOOTING

#### OBSTRUCTIONS

If you are not getting any abrasives or air out of the blast nozzle, start by depressurizing the machine and then checking for a clogged nozzle. If you are only getting air and no abrasives, try fully opening the abrasive valve and quickly opening and closing the choke valve. If that doesn't work, depressurize the machine and remove the inspection door assembly to check for any foreign objects (such as paper) inside the machine.

#### ABRASIVE SURGE

Abrasive surge refers to the sudden and temporary increase in the flow of abrasive material during the startup of a blasting system. While some degree of abrasive surge is normal, it can be stabilized by quickly opening and closing the choke valve. If the abrasive surge continues, it may indicate an issue with the blasting system, such as excess moisture. To solve this issue, a moisture/water separator can be installed in the air line closest to the machine. This can help prevent intermittent abrasive flow caused by excess moisture in the system.

#### REMOVAL OF MOIST ABRASIVES

To remove moist abrasive from the system, you will need to disconnect the blast hose and remove the rubber gasket from the quick coupling on the machine. Then, close the choke valve and open the abrasive valve. Next, pressurize the machine to force out any moist abrasive.

# BLAST MACHINES

## DRAWINGS & PARTS LIST

### BLAST MACHINE WITH FSV

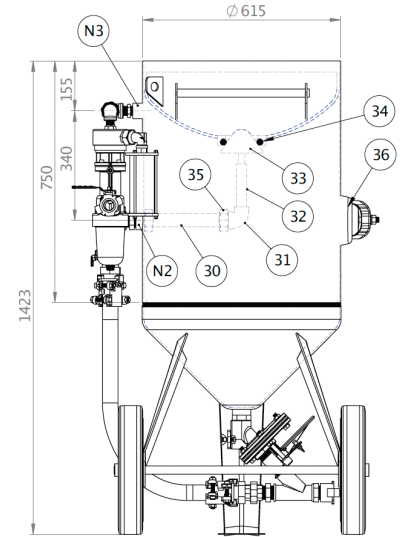
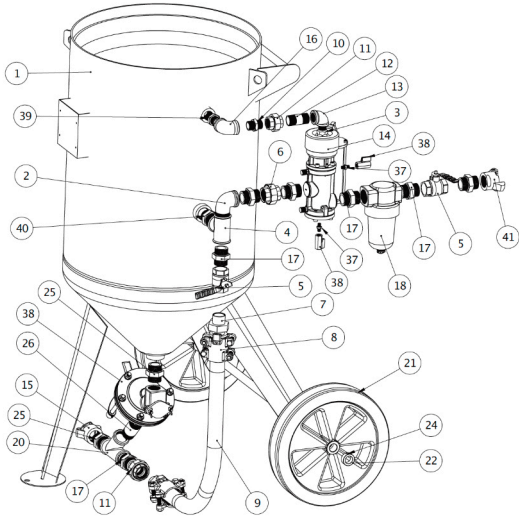

#	DESCRIPTION	QTY	#	DESCRIPTION	QTY
01	BARE BLAST MACHINE	1	23	DEADMAN'S HANDLE (NOT SHOWN)	1
02	ELBOW 1¼"(M) 1¼"(F)	1	24	GRUB SCREW M8	2
03	NIPPLE ¾" BSP(M) X ¾" BSPT(M)	1	25	RUBBERIZED NIPPLE 1¼"	2
04	T-PIECE 1¼"(F)	1	26	RUBBERIZED PIPE 1¼"	1
05	BALL VALVE 1¼"(F)	2	27	SIEVE (NOT SHOWN)	1
06	UNION 1¼"(F)	2	28	LID (NOT SHOWN)	1
07	TALL HOSE NIPPLE 1¼"	2	29	FLAT SAND VALVE 1¼"	1
08	STEELCLAMP HOSE 1¼"	2 SET	30	PIPE NIPPLE 1¼" BSP(M) X 1¼" BSP(M) 282 LONG	1
09	RUBBER HOSE 1¼"	1	31	ELBOW 1¼"(F) X 1"(F)	1
10	NIPPLE 1"(M) 1"(M)	1	32	PIPE NIPPLE 1" BSP(M) X 155 LONG	1
11	UNION 1"(F)	1	33	CONE TYPE POPUP VALVE	1
12	PIPE NIPPLE 1"(M) X 1"(M) X 68 LONG	1	34	POP UP VALVE O RING	1
13	ELBOW 1"(F) X ¾"(F)	1	35	NUT FOR INLET PIPE	2
14	REMOTE CONTROL VALVE WITH SILENCER 1¼"	1	36	INSPECTION DOOR ASSEMBLY	1
15	2 JAW CLAW COUPLING 1¼" WITH PACKING	1	37	NIPPLE ¼" BSP	2
16	ELBOW 1"(F) X 1"(F)	1	38	MINI BALL VALVE ¼"	2
17	NIPPLE 1¼"(M) X 1½"(M)	2	39	NIPPLE 1"(M) 1"(M)	1
18	HALF LITRE MOISTURE SEPERATOR 1½" X 1½"	1	40	NIPPLE 1¼"(M) X 1¼"(M)	5
20	RUBBERIZER Y-PIECE 1¼"(F) X 1¼"(F)	1	41	2 JAW CLAW COUPLING 1¼" WITH PACKING	1
21	RUBBER WHEEL Ø400	1	42	TWIN LINE HOSE ¼" (NOT SHOWN)	20M
22	WHEEL BUSH	2			

# BLAST MACHINES

## DRAWINGS & PARTS LIST

### BLAST MACHINE WITH MICRO VALVE

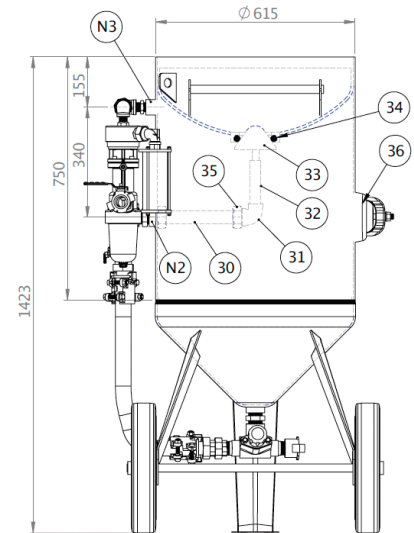
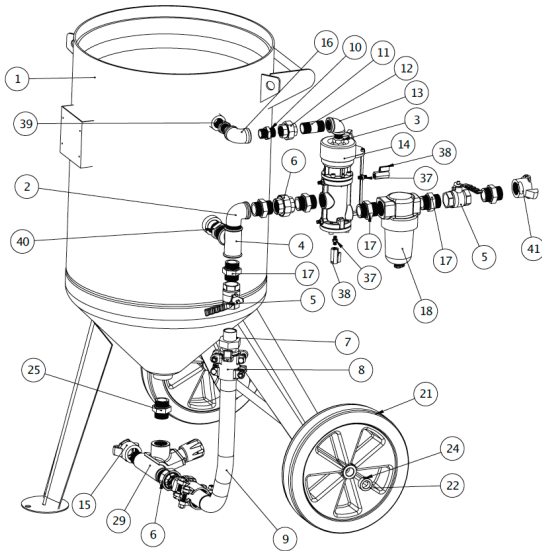

#	DESCRIPTION	QTY	#	DESCRIPTION	QTY
01	BARE BLAST MACHINE	1	22	WHEEL BUSH	2
02	ELBOW 1¼"(M) X 1¼"(F)	1	23	DEADMAN'S HANDLE (NOT SHOWN)	1
03	NIPPLE ¾" BSP(M) X ¾" BSPT(M)	1	24	GRUB SCREW M8	2
04	T-PIECE 1¼"(F)	1	25	RUBBERIZED NIPPLE 1¼"	1
05	BALL VALVE 1¼"(F)	2	26	TWIN HOSE ¼" (NOT SHOWN)	20M
06	UNION 1¼"(F)	2	27	SIEVE (NOT SHOWN)	1
07	TALL HOSE NIPPLE 1¼"	2	28	LID (NOT SHOWN)	1
08	STEELCLAMP HOSE 1¼"	2 SET	29	MICRO VALVE 1¼" BSP(M) X 1¼" BSP(M)	1
09	RUBBER HOSE 1¼"	1	30	PIPE NIPPLE 1¼" BSP(M) X 1¼" BSP(M) 282 LONG	1
10	NIPPLE 1"(M) X 1"(M)	1	31	ELBOW 1¼"(F) X 1"(F)	1
11	UNION 1"(F)	1	32	PIPE NIPPLE 1" BSP(M) X 155 LONG	1
12	PIPE NIPPLE 1"(M) X 1"(M) X 68 LONG	1	33	CONE TYPE POPUP VALVE	1
13	ELBOW 1"(F) X ¾"(F)	1	34	POP UP VALVE O RING	1
14	REMOTE CONTROL VALVE WITH SILENCER 1¼"	1	35	NUT FOR INLET PIPE	2
15	2 JAW CLAW COUPLING 1¼" WITH PACKING	1	36	INSPECTION DOOR ASSEMBLY	1
16	ELBOW 1"(F) X 1"(F)	1	37	NIPPLE ¼" BSP	2
17	NIPPLE 1¼"(M) X 1½"(M)	2	38	MINI BALL VALVE ¼"	2
18	HALF LITRE MOISTURE SEPERATOR 1½" X 1½"	1	39	NIPPLE 1"(M) X 1"(M)	1
19	45° ELBOW 1¼"(M) X 1¼"(F)	1	40	NIPPLE 1¼"(M) X 1¼"(M)	5
21	RUBBER WHEEL Ø400	1	41	2 JAW CLAW COUPLING 1¼" WITH PACKING	1

# BLAST MACHINES

## REMOTE CONTROL SYSTEM RCV-125

### INSTRUCTION MANUAL

The RCV-125 remote control system for single chamber blast machines' operation and maintenance are covered in this manual.



#### KEY CONSIDERATION

Prior to and after each day of operation, it is crucial to inspect the valve for any potential water content by opening the drain petcock. If an excess amount of water is detected, check the water separator. The safety petcock stops the blasting process when it is opened. During breaks, the valve should be open.

#### DESCRIPTION RCV-125

This remote control system, RCV-125, is intended to work with all single chamber blast machines that have 1¼" machine piping. The control valve of RCV-125 comprises of two valves housed together. The bottom valve controls the primary air supply to the machine, while the top valve operates the blow-off connection of the blast machine.

The compressor and the moisture separator are directly linked to the lower chamber via the inlet port. Therefore, the red part of the twin-line control hose remains pressurized throughout the operation. The upper chamber is connected to the blue part of the twin-line control hose through the ¼" port.

#### DEADMAN HANDLE

When the deadman handle is activated, it completes a circuit in the twin-line control hose. The pressurized chamber moves the upper and lower valves away from each other. In this state, the air supply flows through the lower valve to reach the blast machine and nozzle. The upper valve, however, closes the blow-off connection using the diaphragm.

#### SHUT-DOWN

Releasing the deadman handle connects the pressurized red hose to the atmosphere through a restricted path in the deadman handle's connection. Meanwhile, the blue hose is freely connected to the atmosphere through the deadman handle. In this scenario, the blow-off pressure forces the upper valve downward, enabling the pressure inside the blast machine to escape via the port into the bleed-off manifold chamber, and then through the silencer to the atmosphere.

#### TRUSTWORTHINESS OF THE SYSTEM

All moving and crucial components in this system are isolated from the air released during blow-off by the blast machine. The diaphragm prevents any harm to the valve parts if grit particles appear in the blow-off airflow. Valve maintenance is straightforward to conduct and does not necessitate any specialized tools.



# BLAST MACHINES

## INSTALLATION GUIDELINES RCV-125

### PLEASE FOLLOW THE INSTRUCTIONS BELOW TO INSTALL THE SYSTEM

#### INSTALLATION STEPS

Your blast system comes with all the necessary parts for setting up your remote-controlled single chamber blasting operation. In addition to this literature, it also includes the blast machine operations manual.

The instructions below must be followed to complete the installation.

1. Ensure that all connections are airtight.
2. Check that the colored or letter-marked connections on the control valve and deadman handle are properly connected. A cross-linkage may result in an inoperable system.
3. Securely tie down the deadman handle to the blast hose just behind the nozzle holder.
4. It is recommended to tie the twin-line control hose to the blast hose at approximately every 1.5m.
5. Connect the blast hose to the machine and nozzle.
6. Connect the helmet air filter to the air supply from the machine piping and to the blast helmet.



#### KEY CONSIDERATIONS

Avoid tightening the nipples excessively, particularly on the control valve, as this can result in damage to certain components and lead to leakage.

#### ON-SITE INSTALLATION

To convert your blast machine to a remote-controlled system, you need to perform the following steps:

1. Take out the blow-off assembly from the blast machine.
2. Disconnect the primary air supply to the machine from the inlet elbow.
3. Follow the set-up guidelines provided on page 4.



#### KEY CONSIDERATIONS

Moisture separators should always be used in combination with the remote control system to prevent excessive wear to the control valve and optimize the blasting operation.

# BLAST MACHINES

## REMOTE CONTROL SYSTEM OPERATION

### START BLASTING

Before operating the remote control system, ensure that you fully understand the blast machine manual. Then, follow these steps:

1. Verify that all connections from the compressor up to the nozzle are properly fixed to avoid any serious damage caused by a loose-coming compressor air hose.
2. Fill the blast machine with abrasive.
3. Take necessary safety precautions for yourself and your environment, including wearing proper clothing and ensuring a clean air supply to the helmet.
4. Always check if the lever of the deadman handle is in a safe position with the lock upright before operating.
5. Close both petcocks on the control valve.
6. Check for any leakage, ensuring that air should only escape from the hole underneath the lever of the deadman handle.
7. The system is now ready to be pressurized.



#### KEY CONSIDERATIONS

During break time, always open the safety petcock on the control valve (opposite blue twin-line connection).

### OPERATION

1. To start blasting, flip over the safety guard of the deadman handle and activate the lever.
2. To stop blasting, release the lever and the safety guard will automatically flip back.



#### KEY CONSIDERATIONS

During break time, make sure to open the safety petcock located on the control valve that is opposite to the blue twin-line connection.



#### CAUTION

Fixing the lever of the deadman handle in the blast position should never be done, as it can lead to serious injury.

# BLAST MACHINES

## RCV-125 MAINTENANCE GUIDELINES

### MAINTENANCE GUIDELINES

#### VALVE DISASSEMBLY STEPS

1. Begin by disconnecting the control valve from the blast machine.
2. Next, remove the nipple located on top of the control valve.
3. Proceed to take off the bleed-off manifold along with the silencer assembly. The silencer cartridge can be disassembled by referring to the breakdown drawing. Take care when re-assembling the silencer cartridge support adjustment.
4. Remove the screws to take away the top cover, the blow-off diaphragm, the bleedoff cylinder housing, and the bottom plate. Ensure that the packings are handled with care.
5. To remove the bleed-off cylinder and piston, securely hold the piston with an appropriate tool (taking care not to damage the aluminum), and unscrew the screw. O-rings and seals can now be inspected.
6. For inspection purposes, to remove the inlet valve and piston, hold the inlet valve using a 5 mm steel pin inserted through the 1¼" machine connection side of the control valve. This pin should fit into the hole at the center of the inlet valve. Once this is in place, release the screws and take away the piston and inlet valve.

#### VALVE ASSEMBLY

To re-assemble the control valve, reverse the steps above. It is advisable to replace the parts marked (\*) in the parts list in a timely manner to prevent excessive wear and damage to the control valve.



#### CAUTION

Re-assembling worn parts should never be done as they can unnecessarily damage the control valve.

#### INSPECTIONS

Daily inspection should include:

1. Inspect the control valve for water content. If there is any water present, examine the water separator's condition.
2. Verify that the rubber insert on the deadman handle is in good condition. If it appears worn or damaged, replace it.
3. Evaluate the condition and proper fixation of all hoses and fittings.

It is advisable to carry out the following tasks either once a month or after every 160 working hours:

1. Assess the condition of the silencer and its piping.
2. Inspect all air connections for leaks.
3. To disassemble the control valve, follow the valve disassembly steps above and thoroughly examine all moving parts. If any signs of wear are visible, it is recommended to replace them to prevent any unnecessary damage. After reassembling the valve, apply general purpose lubrication oil to the moving parts.

# BLAST MACHINES

## PROBLEM-SOLVING RCV-125

### PROBLEM-SOLVING

#### INTRODUCTION

If the remote control system is not functioning properly, use the following checklist to troubleshoot the problem:

1. Refer to the instructions provided in this manual.
2. Check all air hoses and connections for any air-leaks.
3. Ensure that the safety and drain petcocks are closed.
4. Inspect the deadman handle for air-leaks:
  - In the released position, air should only be escaping from the body hole.
  - In the pressed position, no air should escape from the handle at all.

#### COMMON KNOWN ISSUES

- If no air is escaping from the body hole in the deadman handle, it may be due to the twin-hose being clogged or squeezed. Try removing the twin-line and check for blockages.
- If the system does not start, first check if the safety petcock is open. Ensure that there is enough air supply to the blast and that all parts of the machine are functioning correctly. If the safety petcock is open, close it, and disassemble the control valve to investigate further. Make sure that all parts move freely before reassembling the valve.
- If the system will keep running and won't shut down, it could be due to clogged channels in the deadman handle, incorrect hose connections, or a defective control valve. Try removing the handle and cleaning it. Check the connections and switch them back to their proper positions if necessary. If the problem persists, disassemble the valve and check for proper operation.

# BLAST MACHINES

## DRAWING & PARTS LIST RCV-125

### RCV-125 REMOTE CONTROL VALVE

#	ITEM NO.	DESCRIPTION	QTY
01	20206000	VALVE HOUSING	1
02	20206100	BLEED-OFF CYLINDER HOUSING	1
03	20206200	BLEED-OFF MANIFOLD	1
04	20206300	TOP COVER	1
05	20206400	INLET VALVE	1
06	20206500	BLEED-OFF CYLINDER	1
07	20206600	PISTON	2
08	20206700	BOTTOM PLATE	1
09*	20206800	DIAPHRAGM	1
10*	20206900	PISTON SEAL	2
11*	20207000	O-RING	3
12*	20207100	PACKING	2
13	20178000	BRASS HEX NIPPLE 1/4"	1
14	20178000	BRASS HEX NIPPLE 1/4"	1
15	20152000	BALL VALVE 1/4"	2
16	20207200	PISTON SCREW 8X15	2
17	30225400	HEX NIPPLE 3/4"	1
18	20207400	SCREW 8X25	12
19	20207600	SILENCER HOUSING	1
20	20207700	SILENCER TOP COVER	1
21	20207800	SILENCER BOTTOM PLATE	1
22	20207900	SILENCER HOUSING PIN 5X215	3
23	20208000	SILENCER CARTRIDGE	1
24	20208100	SILENCER CARTRIDGE SUPPORT	1
25	20208600	NUT	6
26	20208400	UNION ELBOW	1
27	30225400	HEX NIPPLE 3/4"	1
28	20208700	CHECK VALVE (NOT SHOWN)	1
29	20207500	PLUG 1/4" (NOT SHOWN)	1
30*	20209600	O-RING	1

**To minimize downtime, it is recommended to keep the following spare parts in reserve:**

RCV-125 Repair Kit (item number: 20205000)

Rubber insert for DMH-125 (item number: 20203600)

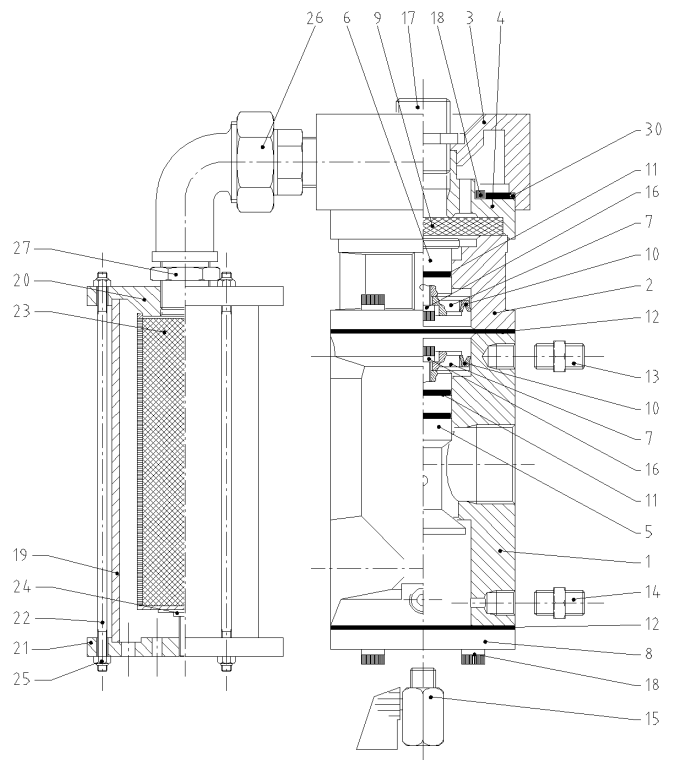

**All parts marked (\*) are included in the RCV-125 repair kit (item no: 20205000)**

# BLAST MACHINES

## DRAWING & PARTS LIST DMH-125

### DMH-125 DEADMAN HANDLE

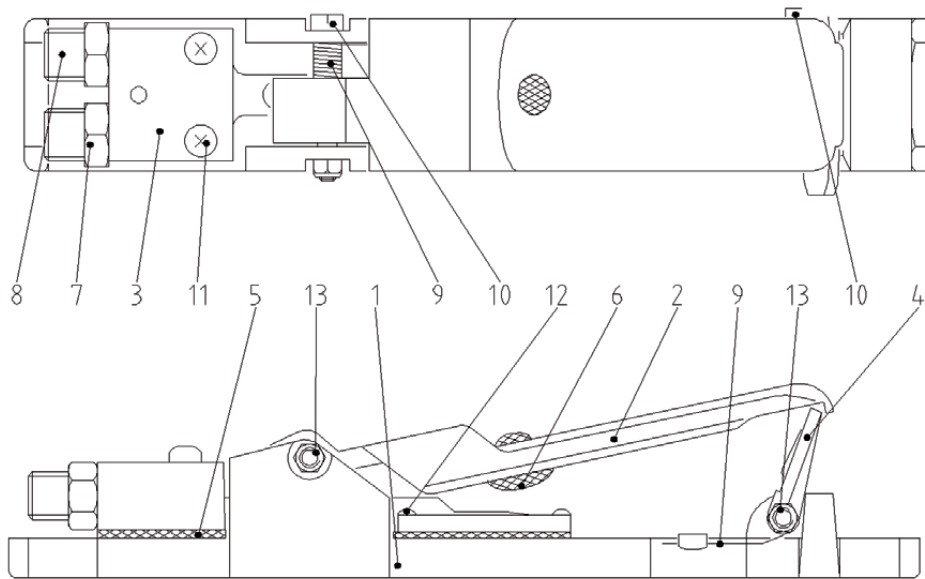

#	ITEM NO.	DESCRIPTION	QTY
01	20203100	HANDLE BODY	1
02	20203200	LEVER	1
03	20203300	PNEUMATIC MANIFOLD	1
04	20203400	LEVER SAFETY LOCK	1
05	20203500	GASKET	1
06	20203600	RUBBER INSERT	1
07	20203700	REDUCTION NIPPLE 1/4" X 1/8" (RESTRICTED)	1
08	20203800	REDUCTION NIPPLE 1/4" X 1/8"	1
09	20203900	SPRING	2
10	20204000	SCREW 5 X 40	2
11	20204100	SCREW 4 X 25	2
12	20204200	SCREW 4 X 10	4
13	20204300	LOCK NUT	2

# BLAST MACHINES

## AIR REQUIREMENT TABLE

### CALCULATED MINIMUM AIR VOLUME (AT 100 PSI)

NOZZLE NO.	AIR VOLUME	HELMET ATTACHED	RESERVE NEEDED	MIN. REQUIRED AIR VOLUME
4 (6.5 MM)	2.3 M <sup>3</sup> /MIN	0.5 M <sup>3</sup> /MIN	1.4 M <sup>3</sup> /MIN	4.2 M <sup>3</sup> /MIN
5 (8.0 MM)	3.9 M <sup>3</sup> /MIN	0.5 M <sup>3</sup> /MIN	2.2 M <sup>3</sup> /MIN	6.6 M <sup>3</sup> /MIN
6 (9.5 MM)	5.5 M <sup>3</sup> /MIN	0.5 M <sup>3</sup> /MIN	3.0 M <sup>3</sup> /MIN	9.0 M <sup>3</sup> /MIN
7 (11.0 MM)	7.2 M <sup>3</sup> /MIN	0.5 M <sup>3</sup> /MIN	3.9 M <sup>3</sup> /MIN	11.6 M <sup>3</sup> /MIN
8 (12.5 MM)	9.6 M <sup>3</sup> /MIN	0.5 M <sup>3</sup> /MIN	5.0 M <sup>3</sup> /MIN	16.1 M <sup>3</sup> /MIN

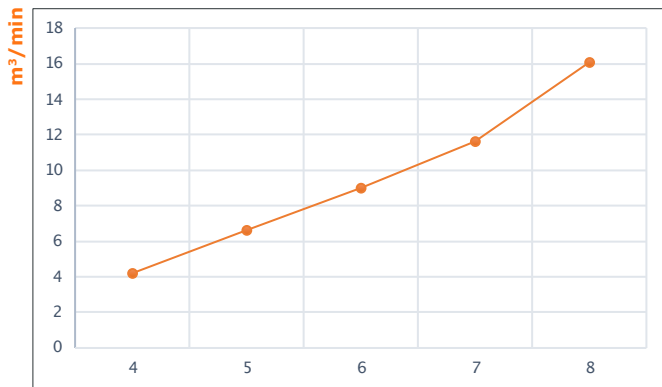

Nozzle No.

NOZZLE NO.	AIR VOLUME	HELMET ATTACHED	RESERVE NEEDED	MIN. REQUIRED AIR VOLUME
4 (¼")	81 CFM (CU FT/MIN)	20 CFM (CU FT/MIN)	50 CFM (CU FT/MIN)	151 CFM (CU FT/MIN)
5 (5/16")	137 CFM (CU FT/MIN)	20 CFM (CU FT/MIN)	79 CFM (CU FT/MIN)	236 CFM (CU FT/MIN)
6 (3/8")	196 CFM (CU FT/MIN)	20 CFM (CU FT/MIN)	108 CFM (CU FT/MIN)	324 CFM (CU FT/MIN)
7 (7/16")	254 CFM (CU FT/MIN)	20 CFM (CU FT/MIN)	137 CFM (CU FT/MIN)	411 CFM (CU FT/MIN)
8 (½")	338 CFM (CU FT/MIN)	20 CFM (CU FT/MIN)	179 CFM (CU FT/MIN)	537 CFM (CU FT/MIN)

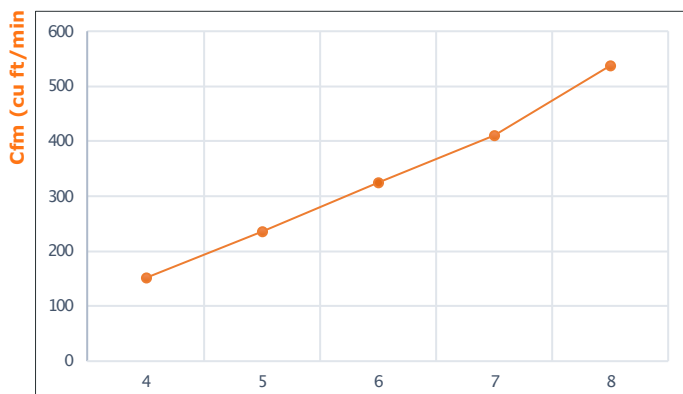

Nozzle No.

# BLAST MACHINES

## WARRANTY

### **WE STAND BEHIND THE QUALITY OF OUR PRODUCTS, PLEASE REVIEW OUR WARRANTY TERMS FOR MORE INFORMATION.**

Novablast guarantees all equipment manufactured under its name and sold through an authorized distributor to be free of defects in material and workmanship at the time of sale. If any part of the equipment is found to be defective within twelve months from the date of sale, Novablast will repair or replace it. This warranty is applicable only if the equipment is installed, operated, and maintained according to Novablast's written recommendations.

However, Novablast is not responsible for any malfunction, damage, or wear caused by improper installation, misapplication, corrosion, inadequate or improper maintenance, negligence, tampering, or substitution of non-Novablast components. Novablast is also not liable for any malfunction, damage, or wear caused by the use of non-Novablast equipment, structures, accessories, or materials.

If the equipment is claimed to be defective, it must be returned to an authorized distributor for verification. If the defect is verified, Novablast will repair or replace any defective parts free of charge. If no defect is found, repairs will be made at a reasonable charge.

The terms of this warranty are the purchaser's exclusive remedy and supersede any other warranties, including merchantability or fitness for a particular purpose, and any non-contractual liabilities based on negligence or strict liability. Novablast is not liable for any direct, special, or consequential damages or loss, and its liability is limited to the purchase price. Any action for breach of warranty must be brought within two years of the sale date.

Novablast does not provide a warranty for accessories, equipment, materials, or components sold but not manufactured by Novablast. Such items are subject to the warranty, if any, of their manufacturer. Novablast will provide reasonable assistance in making any claim for breach of these warranties.