

# TRANSPORT & CONSTRUCTION™

**WE PLACE BUYERS AND SELLERS TOGETHER**

**INFORMATION ON:**

New and Used Construction Equipment, Cranes, Forklifts, Mining Equipment, Parts and Services, Material Handling, Trucks, Trailers, Busses and Engineering Equipment



March 2024  
Volume 30 No.03

Price: R.S.A R23.00  
Neighbouring State R46.00  
[www.transportandconstruction.co.za](http://www.transportandconstruction.co.za)



**C.T.C. PLANT COMPANY (PTY) LTD**  
SINCE 1992

## TRANSPORT SPECIALISTS OF EARTHMOVING PLANT & EQUIPMENT

### OUR SERVICE:

We also have several trailers on hand to meet the many needs of our customers, this includes:

- ☑ Step Decks
- ☑ Well Decks
- ☑ Folding Goosenecks
- ☑ Low Bed Trailers



### WHY CHOOSE US ?

We have a mixed fleet of nine Mercedes-Benz and MAN trucks that consists of three- and four- axle trucks and a crane truck. Whether you need local delivery or long- haul transport, our team is up to the task.

### SPECIALISED TRANSPORT SERVICES

We offer heavy equipment transport services (pick-up and delivery) to all major cities across South Africa, including Johannesburg, Pretoria, Durban, Nelspruit, Port Elizabeth and Kimberly.

**GUARANTEED  
FAST & RELIABLE**

[www.ctcplant.com](http://www.ctcplant.com)

Contact Dudley For More Details



**082 495 2640**



# TEMPO ATTACHMENTS

## GROUND BREAKING TECHNOLOGY



Tempo Attachments boasts **superior design, reliable quality control**, and a total commitment to our policy ensures a **high level of customer satisfaction**.



### TEMPO ATTACHMENTS

c/o Michigan & Manchester Streets  
Airport Industria | Cape Town | South Africa  
Tel: +27 21 386 4190 | Fax: +27 21 386 9303

[www.tempoattachments.com](http://www.tempoattachments.com)  
[info@tempoattachments.co.za](mailto:info@tempoattachments.co.za)



Hydraulics • Foundry • Engineering  
"Engineering Africa"

# CYLINDER REPAIR AND MANUFACTURE

*Africa's Largest Remanufacturer of*

# HYDRAULIC EQUIPMENT



WE HAVE A COMPREHENSIVE STOCK OF  
**NEW PARTS** AND **EXCHANGE UNITS** FOR:

- Caterpillar • Komatsu • Volvo • Bell • Rexroth/Hydromatic • Staffa • Kawasaki • Case
- Linde • Sumitomo • Hitachi • Poclain • Sunstrand/Eaton • Vickers • Hyundai • Doosan



OTHER BRANCHES IN:  
**SPRINGBOK, CAPE TOWN**



CAT 428/424 Pumps  
Bell B20/B25 Pumps  
(NEW & RECON)



VICKERS  
TA1919 Pumps  
(RECON)



KAWASAKI Pumps  
(NEW & RECON)



VICKERS MFE19  
Motors (RECON)

## JOHANNESBURG

TEL: +27 11 882 8413  
Clinton: 082 652 8897 | EMAIL: [clinton@pex.co.za](mailto:clinton@pex.co.za)  
Teresa: 082 658 7301

## CAPE TOWN

TEL: +27 21 556 3232  
FAX: +27 21 557 9948  
NICK: 073 173 1597 | EMAIL: [nick@pex.co.za](mailto:nick@pex.co.za)



# MACHINERY CONTRACTORS

**We design and manufacture our own Bull Dog range of Buckets, Quick Couplers, Heavy Duty Forks, Rake Booms, Slab Masters and more.**

The MC Tyre Handler range is capable of handling any size of tyre. The Tyre Handler can be attached to a Wheel Loader, Crane and Forklift and is remote control operated, enabling the operator outside the driver's cab, to control precise fitment of the tyre and rim onto earthmoving trucks or machines.

We also manufacture Cable Reelers handling cables ranging from 95 mm<sup>3</sup> - 120 mm<sup>3</sup>. The Cable Reeler is a fully hydraulically operated system integrated on a Wheel Loader or Wheel Dozer.

The Hydraulic pressure on the Cable Reeler can be manipulated and adapted to operate in various open cast mining operations.

We are committed to customer service and provide warranties where applicable. We are proud of our facilities and therefore offer specialised service and products. We have long-standing relationships with our customers and will gladly provide trade references on request.



*Machinery Contractors specializes in:  
Buckets, Rippers, Quick Coupler Systems, Tyre  
Handlers, Cable Reelers, Water Tankers and more.*

**Where Other Companies Stop, Machinery Contractors Only Starts.**



info@machinerycontractors.co.za    Tel: +27(0)12 250 3534    Tel: +27(0)12 250 8956



# MACHINERY CONTRACTORS

## WE DESIGN, MANUFACTURE AND REPAIR EARTHMOVING EQUIPMENT AND RELATED ATTACHMENTS.

We are committed to excellent customer service and always extend warranties where applicable.

### Services rendered by Machinery Contractors:

- Design, manufacturing and maintenance of earthmoving equipment and attachments
- We specialise in Buckets, Tyre Handlers, Cable Reelers, Quick Coupler Systems and more
- A fully equipped engineering shop for specialised services
- Hydraulic installations and repairs
- Auto Electrician and mechanical artisans for all maintenance on earthmoving equipment
- We build unique equipment on request to our customers specifications
- We offer a Field Service in respect of On-Site Fabrication Repairs, Auto Electrical & Mechanical and On-Site Line boring where Earthmoving Components are repaired and line bored to operate to its original specifications.
- We have a G.E.T Store on site for own use as well as resale of Ground Engaging Tools such as Teeth, Adaptors, Side Protectors and more.
- Official Geith International Ltd Distributor and authorized aftermarket parts and service products provider.
- Official Hartl Rock Crusher and Screeners Distributor and authorized parts and services product provider.



info@machinerycontractors.co.za Tel: +27(0)12 250 3534 Tel: +27(0)12 250 8956

# BELL

# FLASH SALE

PROMO VALID FROM 01 MARCH - 31 MARCH 2024



**R9 994<sup>00</sup>**

**1206 BELL TRACTOR**

KIT: Air compressor & unloader valve repair kit  
PART NO: 268723

**R4 634<sup>00</sup>**

**1206/1226/1706/1866 BELL TRACTOR**

KIT: Actuator & P/brake valve repair kit  
PART NO: 268724



**R19 996<sup>00</sup>**

**B35D/B40D BELL ADT**

KIT: Turbo, heat shield & sleeve  
PART NO: 268725



Contact your nearest Bell Customer Service Centre to discover more.

ALL PRICES EXCL. VAT | VALID WHILE STOCKS LAST | E&OE.

FOLLOW US ON    

E-mail: [bellparts@bellequipment.com](mailto:bellparts@bellequipment.com)  
[www.bellequipment.com](http://www.bellequipment.com)

Strong Reliable Machines  
Strong Reliable Support

# BELL

Bell-2049

# TURBOFIX

"We are the leaders in the turbocharging field"

Est.  
1992



"There is no substitute for quality & service"

Tel: +27 11 814 2299

Fax: +27 11 814 5587

Email: [info@turbofix.co.za](mailto:info@turbofix.co.za)

Web: [www.turbofix.co.za](http://www.turbofix.co.za)

- Servicing all makes and models of turbochargers.
- Service exchange units of most models of turbochargers in stock.
- All new, repair & service exchange units carry a comprehensive 12 month warranty.
- We collect & delivery countrywide.



5 Second Street, Vorsterskroon Ext 3, Nigel, South Africa

# Editor's Page



**CEO**

Tom Lloyd - tom@lloydsgroup.net

**CFO**

Moira Lloyd - moira@lloydsgroup.net

**Design Manager**

Jared Martin - designmanager@lloydsgroup.net

**Mailing Manager / Account Administration**

Rayne De Laurentis - admin@lloydsgroup.net

**Marketing Manager**

Tom Lloyd - finance@lloydsgroup.net

**Sales Manager**

Rayne De Laurentis - sales@lloydsgroup.net

## EDITORIAL CONTENT

**Pg 82 - 83**

**The Importance of Personal Protective Equipment (PPE)**

**Pg 84 - 85**

**Transport & Construction™ Online Shop**

**Pg 86 - 87**

**Transport & Construction™ Rates**

## EDITOR'S PAGES

**Pg 37**

**Monthly Benefits**

**Pg 40 - 42**

**Why Advertise With Us**

**Pg 46 - 48**

**10 Simple Construction Site Safety Rules**

**Pg 51**

**Summer Truck Drivers**

**Pg 92 - 93**

**Index**

## INDUSTRY RELATED TIPS & TRICKS

**Pg 35**

**What Are Some Of The Most Popular Types Of Skid Steer And Track Loader Attachments**

**Pg 43**

**Your Biggest Fan**

**Pg 46 - 47**

**10 Simple Construction Site Safety Rules**

**Pg 49**

**The Advantages Of Disc Brakes For Heavy-Duty Trucks**

**Pg 51**

**Summer Truck Drivers**

**Pg 54 - 55**

**How to Disinfect your Heavy Equipment**

**Pg 58**

**more on - When Is It Time To Replace Your Bulldozer**

**Pg 66 - 67**

**5 Tips For Getting The Most Out of Your Construction Equipment**

**Pg 70 - 71**

**8 Ways To Control Erosion At Construction Sites**

**Pg 74**

**Dumpers And Their Differences**

**Pg 78 - 79**

**Must-Have Tools For The Workshop**

**Pg 82 - 83**

**The Importance of Personal Protective Equipment (PPE)**



The views expressed in this publication do not necessarily reflect the values of Transport and Construction.

All promotional pages are accepted subject to approval of copy and availability of space and whilst such promotional pages are accepted in good faith, the publisher disclaim all liability for trade names and trademarks used by customers. The publisher's reserve the right to decline, cancel or omit a promotional page at any time without assigning a reason and no liability will be accepted for failure of promotional pages appearing for any cause whatsoever, or for any errors therein. When it is not possible to insert promotional pages in the issue requested, they are automatically carried forward to the next issue. No guarantee can be made on the positioning of promotional pages. All rights reserved, no part of this publication may be reproduced or transmitted in any form by any means, including photocopying and recording, without written permission of the publisher.





# VORTEX

TRANSMISSIONS

Dyno Testing  
Valve Body Calibration  
On/Off-Highway Transmission Repairs  
Repairs to Chelsea P.T.O.s

Tel: (011)-452-4430/1 | Johan: 082 333 1005 | Jan: 082 333 1004  
Spares: 072 225 5034 | Email: spares@vortex-vt.co.za

## AUTO COOLING SOLUTIONS<sub>CC</sub>

- Universal Electric Fans
- Counter Clockwise Fans
- Fan Clutches(viscous)
- Electric Fans
- Fan Blades
- Replacement Units
- Fan Blades
- Replacement Units
- Fan Blades
- Replacement Units
- Fan Clutches
- Universal Electric Fans (12V - 10", 12", 14", 16") (24V - 12", 14", 16") etc

For Most Makes of: Motor Vehicles, Pick Ups, Trucks, Busses, Heavy Duty Equipment, Off Road Vehicles

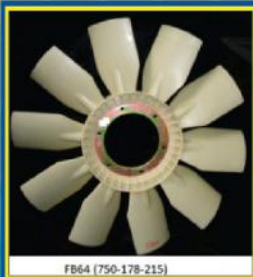

FB64 (750-178-215)



FB94 (750/760-178-215) MAN F2000 Fan



FB8147 (720-180-200) Counter Clockwise Rotation Fan



FB69(610-50-89)Komatsu,Bell,Kato Excavator Fan



FB71 (720-127-152) Volvo and others

**ELAINE PIENAAR**

Tel: +27 (0) 21 982 7114 / 7116  
Cell: +27 (0) 84 681 2513



FB72 (740-127-153) International, Tata, Volvo Fan



Earthmoving Fan

FB65(620-35-80)Hachi,JCB,Mitsubishi

Email: [autocooling@telkomsa.net](mailto:autocooling@telkomsa.net) Web: [www.autocoolingsolutions.co.za](http://www.autocoolingsolutions.co.za) / [www.autofans.co.za](http://www.autofans.co.za)  
Unit 6 & 7 • 14 Tarentaal Crescent, Okavango Park, Brackenfell, 7560



Tel: 011 397 5276 | 011 397 5279 | 011 397 4261

Fax: 011 397 2129

13 Steventon Road, Anderbolt

Boksburg

**SPARES FOR AFRICA**

**Specializing In Spares For JCB Equipment**

**BEE Level 1 Accredited**



**BRANCHES IN  
JOHANNESBURG,  
PORT ELIZABETH  
AND BLOEMFONTEIN**



**Cab Glass for  
BACKHOE LOADERS**



**JCB Engines  
Arriving Soon**



**JCB BUCKETS AVAILABLE!  
TLB TYRES IN STOCK AT GREAT PRICES**

**BRANCHES IN JOHANNESBURG, PORT ELIZABETH AND BLOEMFONTEIN**

**CONTACT CLYDE (JHB) 082 581 5152 | KEITH (PE) 082 602 8745 | ROYVON (JHB) 067 769 4244**

**GET SPARES FOR AFRICA (PTY) LTD**



**SHIN LI**  
**TRADING** (CC)

**ENGINE SPARES**

**LINER KITS, GASKET KITS,  
VALVES & GUIDES, WATER PUMPS,  
OIL PUMPS, CRANK & CAM SHAFTS,  
ENGINE BEARINGS AND BUSHINGS**



**MITSUBISHI**

**KOMATSU**

**DOOSAN**

**NISSAN**

**ISUZU**

**YANMAR**



**KAWASAKI PUMPS**

**NEW AND RECON**

**FINAL DRIVES**

**20 & 30 TON EXCAVATOR  
TM40 & TM60 FINAL DRIVE PARTS  
& COMPLETE UNITS**



**KAWASAKI ROTATING GROUPS**

**K3V AND K5V SERIES  
INNER PARTS  
ROTATING GROUPS AND SEAL KITS**

**UNDERCARRIAGE**



**TRACK LINKS**



**TRACK PLATES  
BOLTS & NUTS**



**SPROCKETS**



**IDLERS**



**TRACK & CARRIER  
ROLLERS**

**CONTACT US:**

**TEL: 011 396 1081**

**SALES2@SHINLITRADING.CO.ZA**

**SALES4@SHINLITRADING.CO.ZA**

**SALES5@SHINLITRADING.CO.ZA**

**ADDRESS:**

**67 HIGH ROAD, BREDELL A/H, KEMPTON PARK**

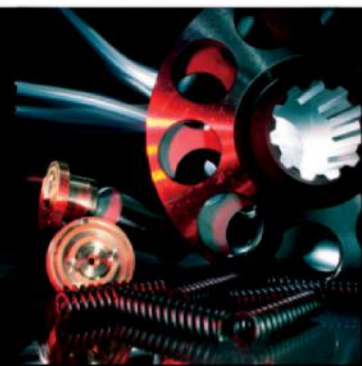



**RHINO**  
Excavator Hammers cc

We Also Do Plant Hire



**Hire: 082 887 8636 | Sales: 071 670 8707 / Office: 074 922 2382**

**sales@rhinohammers.co.za | hire@phplant.co.za | www.rhinoattachments.co.za**



## EDMAR AGENCIES

The Driving Force In Air Brake Compressors

082 447 1333 / 076 262 7449  
011 616 6150 / 011 615 6391  
manny@edmar.co.za  
martin@edmar.co.za

[www.edmar.co.za](http://www.edmar.co.za)



Edmar stocks both **new** and **used** compressors, as well as carrying an extensive range of complete repair kits for all types of compressors at competitive pricing.



## Yumak



Edmar Agencies is one of South Africa's distributors for one of the world's leading air-brake systems' manufacturers, Turkish giant

# CS MORRITT CC

Celebrating  
**26**  
YEARS  
of Service

PROFESSIONAL  
PERSONAL  
QUALITY  
EXPERIENCED SERVICES

Wydan Business Park No 58 Road 5 Unit No 4 Brentwood Park BENONI

## JCB

Parts & Service Specialists

### USED PARTS



[sales@morrittparts.co.za](mailto:sales@morrittparts.co.za)  
082 490 6203 / 011 568 6079

## NOW STRIPPING JCB 540-170 & 535-140

## JCB PART SUPPLIER NEW PARTS

FULLY EQUIPPED WORKSHOP FACILITIES  
AND FIELD SERVICE VEHICLES

[www.csmorritt.co.za](http://www.csmorritt.co.za)

[www.morrittparts.co.za](http://www.morrittparts.co.za)

Tel: 072 614 7044 | Carl: 082 490 6203  
Dean: 061 441 8540 | Email: [csmorritt@gmail.com](mailto:csmorritt@gmail.com)  
[parts@csmorritt.co.za](mailto:parts@csmorritt.co.za) / [sales@csmorritt.co.za](mailto:sales@csmorritt.co.za)  
Fax to Email 086 667 1386

# MP MORRITT PARTS

## Precision Diesel

Precision Diesel strives for quality and excellent workmanship

[www.precision-diesel.com](http://www.precision-diesel.com)



☎ 022 482 1493 / 022 482 3296  
☎ +27 022 487 3117  
✉ [zwang@telkomsa.net](mailto:zwang@telkomsa.net)

## DIESEL FUEL INJECTION & TURBO SPECIALISTS

Repair & Maintenance to all makes of diesel fuel pumps, injectors and turbochargers

*Complete range of authorised parts for diesel fuel injection systems and turbochargers for all makes of trucks, bakkies and passenger vehicles.*

ANNIVERSARY  
**23 Years**  
ANNIVERSARY

WE SPECIALIZE IN THE REPAIR AND SERVICING OF DIESEL PUMPS, INJECTORS AND HIGH-PRESSURE FUEL PUMPS FOR THE AUTOMOTIVE, CONSTRUCTION, LOGISTICS, AGRICULTURAL AND MARINE INDUSTRY.



*Supplier of diesel fuel injection systems.*

*Our injectors provide superior performance and durability.*



📍 18B Schoonspruitweg, Malmesbury, Western Cape, South Africa, 7299

145 Lamp Road, Wadeville, Germiston



# GFA

Gears for Africa

OUR QUALITY COMPARES 100%  
TO ANY OEM SPARE  
MANUFACTURES

011 824 2017

**MANUFACTURE OF SPIRAL BEVEL GEARS NOW AVAILABLE**



**PETREL  
INTERNATIONAL**  
ESTD 1947

*Gears for Africa* products include all types of gears, sprockets, splines and related products for industrial and heavy duty equipment and practically all applications related to power drive systems:

- *Bevel Gears* • *Spur Gears* • *Worm Gears*
- *Helical & Internal Helical Gears*
- *Crown gears* • *Internal & External Splines*

**Petrel International Official Distributors of: Braden/Paccar Winch**

**BRADEN CARCO Gearmatic**

# PACCAR WINCH

**CROWN WHEEL AND PINION, PLANETARY, SUN AND RING GEARS  
FINAL DRIVE GEARS, DIFF HOUSINGS SPIDER CROSS KITS, SPIRAL BEVEL GEARS**

**FOR THE MINING, RAIL, HEAVY EARTH MOVING, CONSTRUCTION  
AND AGRICULTURAL INDUSTRIES**



083 657 0522

carl@gearsforafrica.co.za  
www.gearsforafrica.co.za

Tel: 011 824 2017  
Fax: 011 420 3314

# Sintech

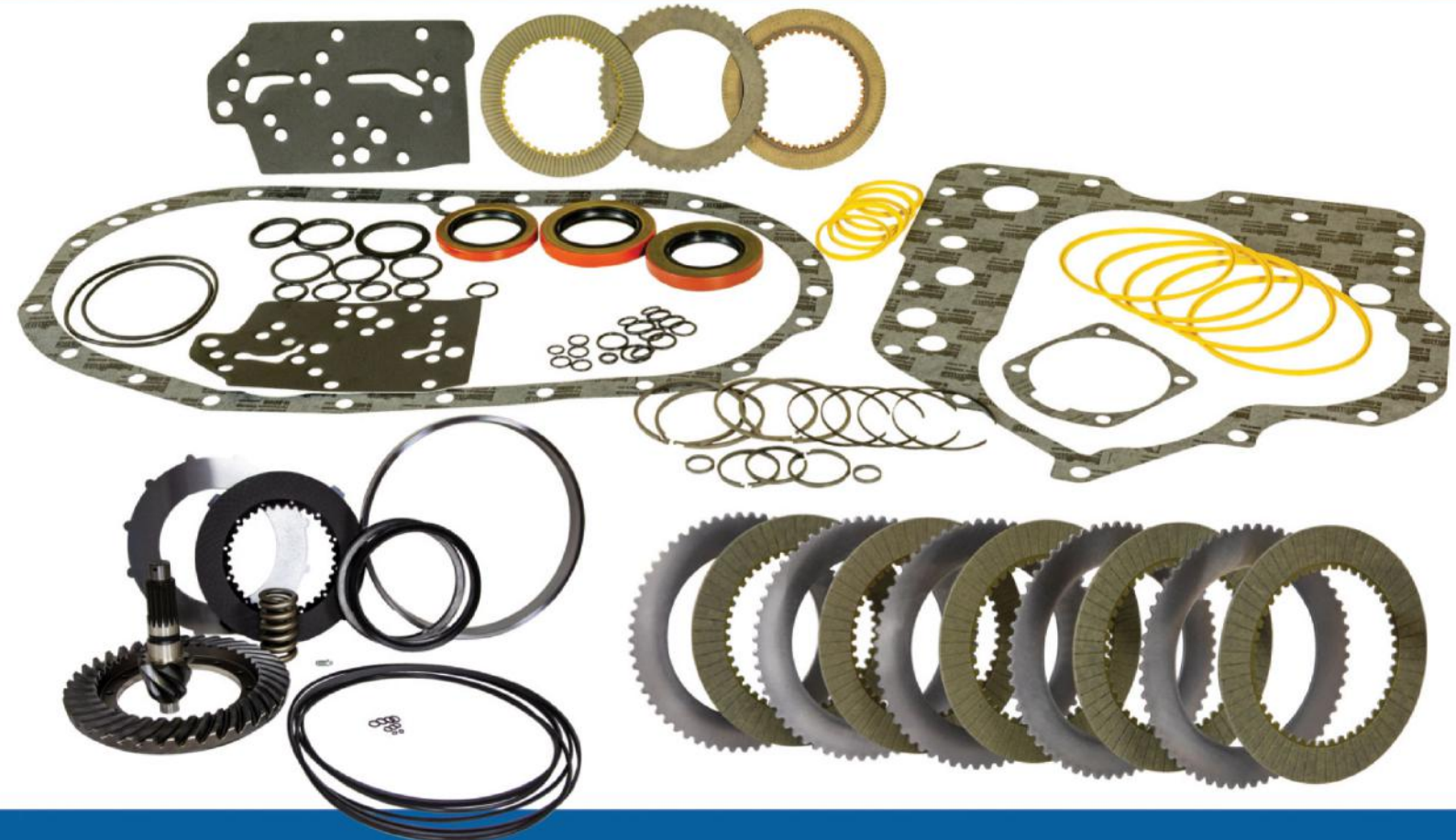

## CLARK DANA AXLE, BRAKE & TRANSMISSIONS

JHB: +27 (0)11 823 2359

[WWW.SINTECH.CO.ZA](http://WWW.SINTECH.CO.ZA)

DUR: +27 (0)31 569 2695

[sales@sintech.co.za](mailto:sales@sintech.co.za)





**WE STOCK  
PRE-OWNED TRUCKS &  
NEW AND USED SPARES**



**With over 40 years experience  
behind us, we provide our clients with  
the best possible advice and service.**

We stock a **LARGE VARIETY** of  
**GAURANTEED SPARES** for all makes  
of trucks and commercial vehicles as  
well as a wide range of **NEW TRUCK  
PARTS**.

**ENGINES:**

Ade | Hino | Isuzu | Mitsubishi | Mazda  
| Man | Nissan | Toyota | Cummins |  
Merc

**CABS:**

Toyota | Isuzu | Hino | Scania | Actros

We stock a **WIDE RANGE** of  
quality **PRE-OWNED TRUCKS**

**STOCK INCLUDES:**

Nissan | Tata | Hino | Toyota  
| Axor | Actros | Man |  
International | Freightliner

**CALL NOW 082 953 4384**

[www.denvertruckspares.business.site](http://www.denvertruckspares.business.site)







## PARTS AND ACCESSORIES FOR SMALL EARTH-MOVERS

With more than **5 million known references**, TVH can provide the widest range of parts for small earth-movers on the market, including tracks, undercarriage parts, filtration, hydraulics, tyres, electrical parts, engine parts, and much more.

Suitable for all major makes on the market, including: **Bobcat, Case, atterpillar, JCB, John Deere, Kubota, Takeuchi, Volvo, Yanmar ...**



[WWW.TVH.COM/BACKHOE](http://WWW.TVH.COM/BACKHOE)

### TVH PARTS SOUTH AFRICA (PTY) LTD • HEAD OFFICE JOHANNESBURG

90 Electron Avenue • Isando • Kempton Park 1600 • South Africa • GPS S -26.130318, E 28.214541  
T +27 11 281 2700 • F +27 11 392 3599 / +27 11 974 9845 • sales.southafrica@tvh.com • www.tvh.com

#### CAPETOWN

4 Buchan Street  
Stikland Industrial  
Bellville, Cape Town 7530  
T +27 21 988 2432  
F +27 21 988 9127

#### DURBAN

5 Peterson Place  
Westmead  
Pinetown 3600  
T +27 31 100 0760  
F +27 31 700 6191

#### LICHTENBURG

Shop 1  
103 Scholtz Street  
Lichtenburg 2740  
T +27 18 632 6192/6092  
F +27 18 632 6108

#### PORT ELIZABETH

220 Commercial Road  
Sidwell  
Port Elizabeth 6001  
T +27 41 453 1404/8  
F +27 41 453 1409

#### RICHARDS BAY

Unit 3 Ferro Park  
1 Ferro Gang Road • Alton  
Richards Bay 3900  
T +27 35 751 1001  
F +27 86 530 3145

# Jumanje

POWER PARTS

SERVICE AND YOUR DOWNTIME IS OUR PRIORITY.  
WE WILL ENDEAVOUR TO FIND WHAT YOU NEED!

AUTOMOTIVE • HEAVY DUTY • CONSTRUCTION  
AGRICULTURAL • MINING • GENERATORS

**25 YEARS CUMMINS EXPERIENCE**  
FOR YOUR CUMMINS ENGINE COMPONENTS

NOW IN STOCK

- Mid-tier range on 4/6 B and 6C Series
- QSB 6.7 | QSC | QSL | ISB | ISF | ISC | L8.9/L9/L10 Series
- Selected ISX15 | QSX15 | NTA855/855 | N14 | M11
- New ISF2.8/ISF3.8 | QSF2.8/QSF3.8 | B3.3 | QSB 4.5

PLUS A WIDE RANGE OF BPK BELTS AND FILTERS

CONTACT US FOR  
**UNBELIEVABLE**  
PRICING AND SERVICE

Follow us on Facebook:  
[www.facebook.com/jumanje4u](http://www.facebook.com/jumanje4u)

**CARRADINE VARKEVISSER**

Tel: 011 976 1242 | Cell: 060 525 9943  
Cell: 063 753 6466  
Email: [sales@jumanje.co.za](mailto:sales@jumanje.co.za)

**Jumanje**  
PROCUREMENT SERVICES

OUR PAGE SIZES

**PRINT  
INSERTION**



Double Page Spread (336mm x 240mm)

Full Page (151mm x 218mm)

1/2 Page (151mm x 107mm)

Front Cover (168mm x 133mm)

Back Cover (168mm x 240mm)

Bookmark (168mm x 240mm)

Centre Spread (336mm x 240mm)

CONTACT US FOR  
**RATES**

☎ 044 382 1606

✉ [finance@lloydsgroup.net](mailto:finance@lloydsgroup.net)

[www.transportandconstruction.co.za/digital-publications/](http://www.transportandconstruction.co.za/digital-publications/)



VIEW OUR  
INTERACTIVE  
**DIGITAL  
PUBLICATION**



044 382 1606 • [finance@lloydsgroup.net](mailto:finance@lloydsgroup.net)

[www.transportandconstruction.co.za](http://www.transportandconstruction.co.za)



We never sell the same parts twice for the same machine.  
***Quality that lasts.***



+27 (0)861 888 008  
+27 (0)83 327 3237 A/H

LNE@LNE-AgriEarth.com  
@LNEAgriEarth

**www.LNE-AgriEarth.com**

**CARRARO**  
Spare Parts  
Authorized Dealer

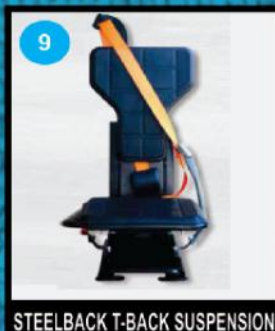
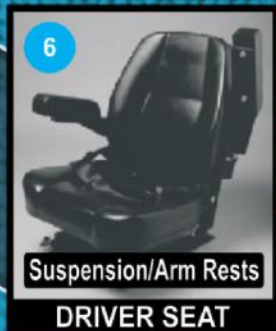
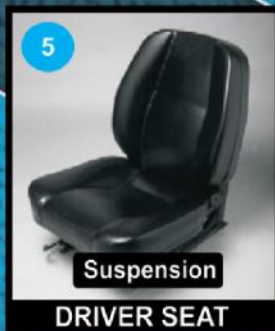
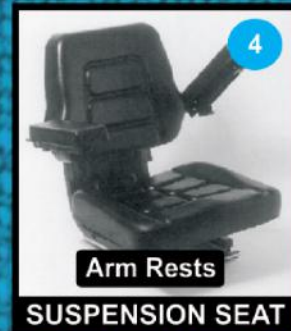
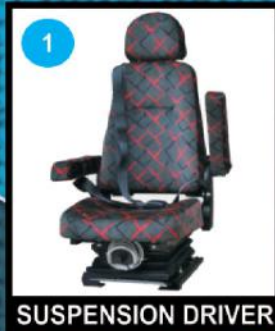

Manufactured according to required specification

**Buy direct from factory for the best prices!**  
 64 Tannery Road, Hamilton, Bloemfontein, South Africa  
 PO Box 35643 Faunaisig 9325  
**Contact person: Johan Britz**  
 Tel: (051) 435-4752 or 435-4450 | Fax: (051) 435-4753  
 e-mail: [permas@mweb.co.za](mailto:permas@mweb.co.za) | website: [www.permaseating.com](http://www.permaseating.com)

Exclusive Distributor for Swedish Lorry Parts in Southern Africa

Tel (011) 918 1397/8

E-Mail:sales@slpsa.co.za

www.slpsa.co.za



SLP South Africa

We don't do "CHEAP"

We do QUALITY

**Power Transmission**  
Transmission Pumps, Gasket Sets, Gears, Propshafts, Universal Joints, Hub Seals, Final Drive and Axle Parts, Wheel Nuts and Studs

**Engine Parts**  
Engine Rebuild Kits, Gasket Sets, Oil Pumps, Inlet and Exhaust Valves and Components, Water Pumps and Repair Kits, Cylinder Liner Sets

**Suspension & Frame**  
H Frame Pins and Bushes, Miscellaneous Pins for Excavators, Dust Seals, Scrapers, Hollow Springs, Suspension Rubbers, Shock Absorbers

**Braking System**  
Brake Discs, Accumulators, Brake Lining Sets, Repair Kits Mineral Oil and Brake Fluid, Pedals, Master Cylinders, Wet Brake Discs

Swedish Manufactured Replacement Parts for Volvo Mining, Truck, Bus, Penta Marine and Industrial applications.

New range of Scania parts available

**011 029 8600**  
[www.at-southafrica.com](http://www.at-southafrica.com)



17 SPARTAN ROAD, SPARTAN  
KEMPTON PARK, 1619



**Engine &  
Transmission  
Spares & Rebuilding**

**100%** Guaranteed fast and  
reliable services

**SECOND HAND SPARES**

**E & A**  
**SPARES**  
(PTY) Ltd



E-mail: [easpares@iafrica.com](mailto:easpares@iafrica.com)



**SPECIALISTS IN:**

Rebuilding of DETROIT Engines (GM)

**DETROIT**

**ALLISON**



**CLARK**

Rebuilds of Transmissions for ALLISON - ZF - CLARK

**(031) 700 5791 / 082 659 5521 - Deva**

UNIT 5, CENTRAL PARK, 24 KYALAMI ROAD,  
WESTMEAD ext, PINETOWN, DURBAN 3608

Specialising in

# EARTH MOVING

## Parts & Rebuilds.

We do **Hydraulics repairs** & stock a wide range of parts.



Hydraulics | New & Used Parts | Machine Rebuilds | Service Exchange Units | Field Service

Dominic: **082 961 7639** | [dominic@komanco.co.za](mailto:dominic@komanco.co.za)

Trevor: **082 779 5606** | [trevor@komanco.co.za](mailto:trevor@komanco.co.za)

☎ 011 396 2675

📍 21 Sim Road, Aston Manor, Kempton Park, Gauteng



# KOMATSU

Finaldrives | Pins & Bushes | Buckets | Cabs | Hoses | Electrical | Radiators |  
Oil Coolers | Valves | Seal Kits | Gearpumps | Track Adjusters | Undercarriage & More

WE STOCK A LARGE RANGE OF COMMERCIAL & PASSENGER

# CRANKSHAFTS

[www.cargocrankshaftrebuilding.co.za](http://www.cargocrankshaftrebuilding.co.za)

### BALANCING

Our Cemb ZE II balancing machine can give you a printout of initial & residual unbalance.

### STRAIGHTENING

Big and small we straighten them all steel & cast-iron shafts.

### CRACK DETECTING

We use ultra violet magnetic particle crack detection. (Crack Test Certificates issued on request)

### DYNA TESTING

Dynamometer tuning and computer diagnostics of all Mercedes-Benz truck applications.



**Cummins ISX Cylinderhead Injector Tubes Installed, (OE Installation Kit)**

**NOW AVAILABLE!**

• Crank and Camshaft Rebuilding • Crack Detecting • Straightening • Balancing • Repositioning of ADE 400 Series Camgear • Engine Rebuilding of commercial, earthmoving equipment, and passenger vehicles • Precision Grinding of shafts up to 2.3m including crankshafts, camshafts, compressors, electrical rotors etc. • Line Boring • Dynamometer Tuning Computer Diagnostics of all Mercedes Benz truck applications

# CARGO

CRANKSHAFT REBUILDING  
(Pty) Ltd



☎ (011) 873 6685 📠 Hendré : 076 791 3927 ✉ [workshop@cargocr.co.za](mailto:workshop@cargocr.co.za)

🏠 21 Main Reef Road, Primrose, Germiston, 1401

Tel: 011 868 5130  
Fax: 086 634 7904  
Cell: 071 684 5784

# MZANTSI

## TRANSMISSIONS



- BELL
- TEREX
- DESMOND
- HITACHI
- DAEWOO
- ZF
- ALLISON
- CLARK
- FUNK

**We offer specialised transmission repairs for heavy duty & on highway machines**



[info@gearboxes.me](mailto:info@gearboxes.me)  
6 van der Bijl  
Alrode South  
Alberton

**WE OFFER DYNO TESTING ON ZF TRANSMISSIONS**





[www.advancedtransmissions.co.za](http://www.advancedtransmissions.co.za)

## DIRECT IMPORTERS OF HEAVY DUTY GEARBOX AND DIFFERENTIAL PARTS

Replacement parts for the following manufacturers:  
DAF, Eaton, Fuller, MAN, Mercedes-Benz, Rockwell, Scania, Volvo and ZF.

Parts are ISO9002 approved and imported from Italy, Germany and USA

Parts include - Seals, Bearings, Brake Discs & Pads, Suspension Components & Front Axles, Hydraulic PTO's and Pumps, Switches & Valves



WE SPECIALISE IN THE REPAIR OF ALL HEAVY DUTY GEARBOXES AND DIFFERENTIALS AT OUR JOHANNESBURG BRANCH

New & Exchange Units available with a 1 Year Warranty

**JOHANNESBURG**  
459 Flower Close,  
Sam Green Road  
Tunney Ext 9, Germiston

Tel: +27 11 822 2221  
Fax: +27 11 822 2216

**PINETOWN**  
Unit 7 Techni Park  
29 Hillclimb Road  
Westmead, Pinetown

Tel: +27 31 700 5905  
Fax: +27 31 700 5911

# MID PLANT SERVICES

**NEW EXCAVATOR PARTS, COMPONENTS AND REPAIRS**



:+27 (0)11 967 0055

:+27 (0)11 967 0060



: SALES@MIDPLANT.COM



: 273 3RD AVENUE, BREDELL,  
KEMPTON PARK, 1619



: WWW.MIDPLANT.COM

**THE ALTERNATIVE SUPPLIER FOR DOOSAN, HYUNDAI, VOLVO  
AND MOST CHINESE EXCAVATORS SOLD IN SOUTH AFRICA.**

**FOLLOW US ON:**



## **Now Available at Mid Plant Services**

At Mid Plant Services, we make an effort to acquire new and diverse parts to ensure that we meet the needs of all our customers.

**If we don't have a part in stock, we will do our best to acquire it promptly.**

### **NEW STOCK**

- Hitachi Main Hydraulic Pumps (HPV102, HPV118 & HPV145)
- Rexroth AP2D28 Hydraulic Pump
- DX225 Trenching Bucket
  - 20Ton Bucket Assy
  - 30Ton Bucket Assy
- Engine Parts and Build Kits
  - Hydraulic Pump Parts
  - Swing Motor Parts
  - Track Adjusters
  - Travel Devices



# Quality Service

## The Secret To Our Success

The Seat Connection provides a complete repair, rebuild or new seating solution for all commercial and industrial vehicles.

Our products are used in trains, trucks, buses, mining and game viewing vehicles, as well as construction equipment and other specialised vehicles. Our services not only include new seat sales, but the complete mechanical rebuild of operator and passenger seats, while our inhouse upholsterer takes care of your upholstery needs.

With over 30 years of service to the transport industry, our solid background, expertise and product knowledge, makes us a leading auto seat specialist.



**IRSI  
AIR NTS**



**KAB  
411**



**KAB  
525**



**The seat  
CONNECTION**



TheSeatConnection



+27 11 452 6802



info@seatconnection.co.za



www.seatconnection.co.za

## Generating the **DEUTZ** way. **DEUTZ DIESELPPOWER**

*Invest In Engineering  
Excellence!*

*Renowned Quality At  
Affordable Prices!*

Please contact our sales department for prices covering our complete Diesel Generator range.

Telephone No: +27 (011) 923 0600

Email: [jaco@deutz.co.za](mailto:jaco@deutz.co.za)

[info@deutz.co.za](mailto:info@deutz.co.za)

Check out our website for the full DEUTZ product range:

Website: [www.deutz.co.za](http://www.deutz.co.za)

Demand Original DEUTZ Products and Services

The engine company.



*"Mobile energy generation - we do it right!"*



# ESP THE PROVEN ALTERNATIVE

## X series Bucket Teeth suitable for the Caterpillar Side Pin System

The ESP X-Series range of bucket tip castings and adapters consists of innovative designs to suit all applications. ESP X-Series bucket tips are designed to offer optimum penetration, durability and maximum utilisation of the wear material. The combination of these features and benefits ensures overall cost effectiveness.

**L**    
LONG



Available Sizes  
J200, J250, J300, J350, J400, J460

**RC**   
ROCK CHISEL



Available Sizes  
J200, J350, J460, J600, J700

**P**   
PENETRATION



Available Sizes  
J350, J460

**RPL**   
ROCK PENETRATION LONG



Available Sizes  
J250, J300, J350, J400, J460

**RP**   
ROCK PENETRATION



Available Sizes  
J200, J300, J350, J460, J550, J700, J800

**RPHD**   
ROCK PENETRATION HEAVY DUTY



Available Sizes  
J300, J350, J460

**Design • Performance • Durability**

**BENEFIT FROM OUR 9 MONTHS WARRANTY PERIOD ON NEW PARTS**

ESP Johannesburg  
Tel: (011) 398-1700

ESP Pretoria  
Tel: (012) 804-6706

ESP Middelburg  
Tel: (013) 246-2520

ESP Pinetown  
Tel: (031) 705-4200

ESP Cape Town  
Tel: (021) 945-1030

ESP Gqeberha  
Tel: (041) 484-4575

ESP Bloemfontein  
Tel: (051) 432-4501

ESP Kimberley  
Tel: (053) 831-8349

ISO 9001 Certified

# ESP THE PROVEN ALTERNATIVE



## Bucket Teeth suitable for the Caterpillar Side Pin System

ETE offers a range of innovative bucket teeth designs known as the Xtrem Series.

The Xtrem Series bucket teeth offer excellent self sharpening and penetration features that are able to maximise the life of the teeth in all applications.

In addition, ETE also produces replica DRP (Direct Replacement Part) bucket teeth and adapters for the Caterpillar Side Pin System.

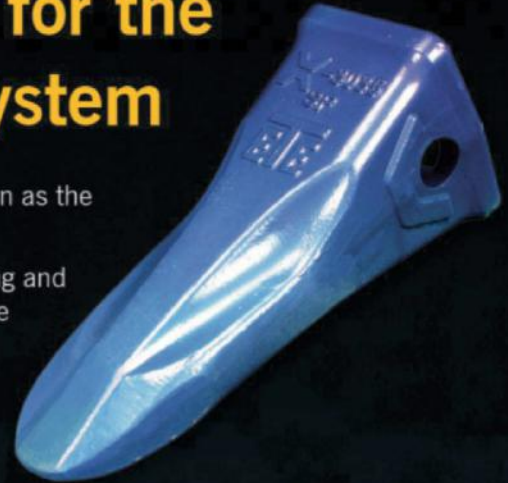

**GD**   
GENERAL SOIL CONDITIONS

Available Sizes  
J200, J250,  
J300, J350,  
J400, J460,  
J550, J600,  
J700, J800



**SP**   
GENERAL & ABRASIVE CONDITIONS

Available Sizes  
J200, J250,  
J300, J350,  
J400, J460,  
J550, J600,  
J700, J800



**PL**   
COMPACTED SOILS

Available Sizes  
J350, J400,  
J460, J550,  
J600, J700



**AH**   
GENERAL & ABRASIVE CONDITIONS

Available Sizes  
J300, J350,  
J400, J460,  
J550, J600,  
J700, J800



**RC**   
EXTREME ABRASIVE CONDITIONS

Available Sizes  
J200, J300,  
J350, J460,  
J550, J600,  
J700, J800



## Design • Performance • Durability

### BENEFIT FROM OUR 9 MONTHS WARRANTY PERIOD ON NEW PARTS

ESP Johannesburg  
Tel: (011) 398-1700

ESP Pretoria  
Tel: (012) 804-6706

ESP Middelburg  
Tel: (013) 246-2520

ESP Pinetown  
Tel: (031) 705-4200

ESP Cape Town  
Tel: (021) 945-1030

ESP Gqeberha  
Tel: (041) 484-4575

ESP Bloemfontein  
Tel: (051) 432-4501

ESP Kimberley  
Tel: (053) 831-8349



# **(ehd)** COMPONENTS 2005 (PTY) LTD t/a ENGINE & HEAVY DUTY COMPONENTS

Distributors of diesel engines, generator and heavy duty engine replacement parts and other equipment to the Automotive, Agricultural, Engineering, Construction, Forestry and Mining industry Suitable For:



ADE  
 BELL  
 Case  
 Caterpillar  
 Cummins  
 DAF  
 Deutz  
 Dong Feng  
 FAW  
 GM Detroit  
 Fiat

Ford  
 Gardner  
 Hatz  
 Hino (Toyota)  
 International  
 Isuzu  
 Iveco  
 John Deere  
 Komatsu  
 Kubota  
 Leyland

Lister  
 Mahindra  
 MAN  
 Massey Ferguson  
 Mercedes  
 Mitsubishi  
 MWM  
 Neuss  
 Nissan  
 Perkins  
 Petter

Renault  
 RVI (Berliet)  
 Ricardo  
 Scania  
 TATA  
 Weichai-Steyr  
 Volvo  
 VW Trucks  
 Yanmar  
 Yangdong

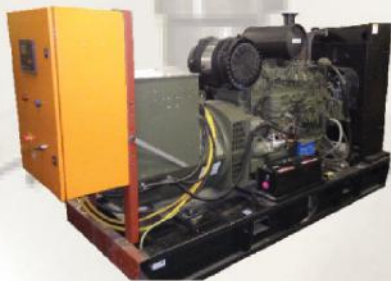

**LOGGER REPLACEMENT PARTS**

**DUMPER TRUCK REPLACEMENT PARTS**

**WWW.EHD.CO.ZA**

**Johannesburg Head office**  
 Tel: 011 870 5000  
 ehd@ehd.co.za

**Durban**  
 Tel: 031 700 1160  
 ehddurban@ehd.co.za

**Bloemfontein**  
 Tel: 051 430 5404  
 ehdbloem@ehd.co.za

**Cape Town**  
 Tel: 021 510 0567  
 ehdcapetown@ehd.co.za

Manufacturer's names, numbers, symbols, photos and descriptions are used for reference purposes only and it is not implied that the parts referred to are the products of those manufacturers. It is specifically recorded that all generator sets, engines or equipment output ratings, per specifications, were measured at sea level and the performance of the generator, engine or equipment may vary according to the altitude at which it is operated

# H.V.R TURBOS



WE ARE THERE FOR YOU .... CALL, WE DO!

## KOOP & VERKOOP

GRONDVERSKUIWINGSMASJINERIE  
TROPKE, SLEEPWAENS, VURKHYSERS  
EN BOORMASJIENE  
OP

WWW.HVRTURBOS.CO.ZA

# HENNING

# 083 755 2177

BRAND  
NEW  
PRODUCTS

## CLEARANCE SALE

Only at Agrico

Mercedes Benz  
OM926la Engine

R 220 000.00 ex



ZF 6WG160 transmission

R 185 000.00 ex



ZF MT-L 3095 Axle 25:1  
ratio front and rear

R 140 000.00 ex



+27 82 374 6938

**AGRICO**  
More than 100 years of service

terms and conditions apply. Terwyl voorraad hou.

VIEW OUR BENEFITS >>

Are you busy planning your **Marketing Strategy?**

# Look no further!

Our promotional services provide your company  
with all that you could ask for and more!

Contact us now to hear our very affordable rates!

TRANSPORT &  
CONSTRUCTION™



044 382 1606



finance@lloydsgroup.net

NEW

# ATVE

All Terrain Vehicles & Equipment (Pty) Ltd

2016



13 000kg



**KAISER  
SPIDER EXCAVATOR**

USED S12 4x4



076 861 7609

piet@atve.co.za

TRANSPORT & CONSTRUCTION™



044 382 1606



finance@lloydsgroup.net

## OUR BENEFITS

- Monthly Publications - Printed & Digital Digests
- Free & Professional Artwork Designs
- Social Media Exposure
- Weekly Newsletter Exposure
- Daily Client Promotional Emails
- Personalised Company Page On Our Website
- Vendorship On Our Online Shop

AND MORE...

www.transportandconstruction.co.za







**ME ENG SUPPLIES**

KEEP IT GENUINE. KEEP IT OEM. KEEP IT REAL.

206 Eureka Street,  
Pomona  
Kempton Park, 1619  
South Africa

+27 11 396 1630  
info@meeng.co.za  
www.meeng.co.za

## Drive Train Components

- Axles
- Brakes
- Transmissions
- Torque Converters

Testing

Parts



Service Exchange

Sales

Repairs

Outright Units

**PARTS**

Dana & Kessler Off Highway Parts:

- Axles
- Transmissions
- Torque converters



# CMS PRODUCTS

Original Equipment Duo Cones for the Following Brands:

BELL  
CATERPILLAR  
KESSLER  
KOMATSU  
VOLVO



And many others - Please contact us to find your nearest stockist

**TENNECO**  
POWERTRAIN

[www.goetze.africa](http://www.goetze.africa)



NEW



All Terrain Tyres  
ROLLS U EVERYWHERE

Your Specialists in

# Imported Tyres



Polyurethane that fills the tyre completely  
SOFT FILL = NO MORE FLAT TYRES



AGRICULTURAL

INDUSTRIAL

WHEELED  
EXCAVATOR

TELEHANDLER  
LOADERS

MIXER  
FEEDER

Tel: +27 72 340 6687

[sales@allterrain tyres.co.za](mailto:sales@allterrain tyres.co.za)

## INCREASE YOUR SALES

Contact us to promote your company now!

Name

Email

Phone Number

Which platform are you interested in?

Message

21+11=

SEND



Should you have any further queries, please do not hesitate to contact me for assistance - Tom Lloyd - 082 894 1672

[finance@lloydsgroup.net](mailto:finance@lloydsgroup.net)



## UPGRADE YOUR SHIPPING EXPERIENCE

We are a level 1 B-BBEE value added contributor offering end-to-end air, sea & land logistics services.

[www.synergyworldwidelogistics.co.za](http://www.synergyworldwidelogistics.co.za)

### Head Office - Durban

107 Escom Road, New Germany, Durban

Tel: +27 31 7057909

### Cape Town Office

1st Floor No 4 Canal Side, Heron Crescent, Century City, Cape Town

Tel: +27 21 4256664

### Johannesburg Office

7 Covora Road, Jet Park, Boksburg, Johannesburg

Tel: +27 11 3971180



## WE WANT TO MEET YOU

With over 27 years of global logistics expertise, we have set ourselves apart as a family-oriented premier end-to-end logistics provider that puts our customers' interests at heart.

In addition to our full service offerings, we offer comprehensive marine insurance, supply chain financing, customs specialisation and project management.

SUCCESS TOGETHER WITH AND ALIKE

TRANSPORT & CONSTRUCTION™



044 382 1606



[finance@lloydsgroup.net](mailto:finance@lloydsgroup.net)

# OUR BENEFITS

- Monthly Publications - Printed & Digital Digests
- Free & Professional Artwork Designs
- Social Media Exposure
- Weekly Newsletter Exposure
- Daily Client Promotional Emails
- Personalised Company Page On Our Website
- Vendorship On Our Online Shop

AND MORE...

[www.transportandconstruction.co.za](http://www.transportandconstruction.co.za)





Pex Hydraulics can take care of your every need with regard to hydraulic repairs and servicing on any scale, be it earthmoving, mining, petrochemical, industrial, forestry, demolition, oil and gas or anything hydraulically operated.



Hydraulics • Foundry • Engineering  
*“Engineering Africa”*

**CAT 428/424 Pumps  
(New & Recon)**



PEX HYDRAULICS: CAPE TOWN  
TEL: +27 21 556 3232 | FAX: +27 21 557 9948  
NICK: 073 173 1597 | JONOTHAN: 082 694 0226  
EMAIL: [nick@pex.co.za](mailto:nick@pex.co.za)

PEX HYDRAULICS: JOHANNESBURG  
TEL: +27 11 882 8413  
Clinton: 082 652 8897 | EMAIL: [Clinton@pex.co.za](mailto:Clinton@pex.co.za)  
Teresa 082 658 7301 | Jennifer 083 405 0203

# What Are Some Of The Most Popular Types Of Skid Steer And Track Loader Attachments?



## BUCKETS

While your skid steer may already come with a general-purpose bucket, you may want something more appropriate for the job at hand. Some buckets have a cutting edge and a particularly low profile, while others may also have a spill guard. 4-in-1 buckets are also very popular, as the wide opening jaws allow for easy loading and dumping. 4-in-1 buckets can also be used for clamping objects like scrap material and logs.

## BROOMS

You'll want to clean up as quickly as possible when your heavy-duty work is done, and for this type of job, you need a broom attachment. As you might expect with these versatile machines, you can choose a broom attachment depending on the environment and the debris. Use a pickup broom with a rotating head that allows you to brush the dirt into the integrated hopper. Angled brooms are perfect for confined spaces (like car parks), where the broom head can be set in a certain position to gather the debris for subsequent pickup.

## TRENCHERS

A trencher is a must-have attachment when you need to lay electrical lines from one part of your property to another or install irrigation ditches to help grow your crops. Many of these devices have an integrated attachment that can also move the displaced soil away from the trench. Choose the attachment based on your required depth, and there are different solutions for varying soil conditions. If you are working in the toughest terrain, fit a trencher attachment with tungsten carbide teeth to breeze through the challenge.

## AUGERS

If you need to dig holes with maximum efficiency, you need an auger for your skid steer loader. These hydraulic devices can be attached easily and will apply significant torque to the job at hand. Choose different bits depending on the scale of the challenge, with standard bits more suited for loose soil and industrial bits preferred for rocky conditions. You'll be able to dig holes for a brand-new fence around your plantation or plant shrubs or saplings at your new nursery.

## POST RAMMERS

Once you have finished digging your holes with the auger attachment, change over to a post rammer. This will allow you to install fence posts safely and with maximum efficiency, no matter the post's size or the hole's depth. You can also get these rammers in a number of different styles, like a drop hammer, vibratory post driver or breaker.

## FORKS

Consider a fork attachment for your skid steer if you need to lift and move cumbersome loads. These devices are widely used on farms or in lumber yards, as well as in various construction environments. Choose from multiple fork tools to give you the required lifting and moving capability. These forks allow you to maintain visibility and deal with heavy loads efficiently and safely.

## SPREADER BARS

When you have rough land that you need to smooth out or have to dress a large area with some new soil to prepare it for seeding, choose a spreader bar attachment. These are designed to level all types of surfaces and fill in the ground smoothly as the machine moves from point to point. The design of the bar will also allow you to transport any excess material to the end of the run, and its attachments can generally level and spread soil in any condition.



# TRANSPORT & CONSTRUCTION™

**WE PLACE BUYERS AND SELLERS TOGETHER**

**INFORMATION ON:**

New and Used Construction Equipment,  
Cranes, Forklifts, Mining Equipment,  
Parts and Services, Material Handling,  
Trucks, Trailers, Busses and  
Engineering Equipment



January 2024  
Volume 30 No.01

Price: R.S.A R23.00  
Neighbouring State R46.00  
[www.transportandconstruction.co.za](http://www.transportandconstruction.co.za)



**CONTACT TOM LLOYD @ 044 382 1606**



# TRANSPORT & CONSTRUCTION™

We offer you  
**MONTHLY NEWSLETTER** EXPOSURE:

Our Newsletter Audience consists of over  
**29 000** subscribers.

*We strive to bring you in touch with your  
perfect buyer/supplier company.*



and  
**MONTHLY SOCIAL MEDIA** EXPOSURE:



We design, post and re-post your artwork  
on all of our social media platforms.

*Putting your company out there.*



**C.T.C. PLANT COMPANY (PTY) LTD**  
SINCE 1992

# TRANSPORT SPECIALISTS OF EARTHMOVING PLANT & EQUIPMENT

## SPECIALISED TRANSPORT SERVICES

We offer heavy equipment transport services (pick-up and delivery) to all major cities across South Africa, including Johannesburg, Pretoria, Durban, Nelspruit, Port Elizabeth and Kimberly.



**GUARANTEED  
FAST & RELIABLE**

## OUR SERVICE:

We also have several trailers on hand to meet the many needs of our customers, this includes:

- ✔ Step Decks
- ✔ Well Decks
- ✔ Folding Goosenecks
- ✔ Low Bed Trailers

## WHY CHOOSE US ?

We have a mixed fleet of nine Mercedes-Benz and MAN trucks that consists of three- and four-axle trucks and a crane truck. Whether you need local delivery or long-haul transport, our team is up to the task.

Contact Dudley For More Details

[www.ctcplant.com](http://www.ctcplant.com)



**082 495 2640**





Designed to **move your loads,**  
not your bank account



Are you looking for a fork positioner, rotator, sidershifter ...? At CAM attachments, we design forklift attachments to meet the unique demands of specific industries. Why? Because years of experience have shown us the difference high-quality, specialised attachments make. We produce them in our own production facilities and deliver them from localised warehouses in the blink of an eye.

T +27 11 281 2700 • F +27 11 392 3599 / +27 11 974 9845  
sales.southafrica@tvh.com

Discover our full range of forklift attachments at  
[www.camattachments.com](http://www.camattachments.com)

# WHY YOU SHOULD BE WITH US

**Marketing your business** can be an expensive task which always leaves you thinking whether or not it is working.

With Transport & Construction™, it doesn't have to be. With your company being placed on **thousands of doorsteps** and in tens of thousands of mailboxes, we make sure you have **no doubt**.

**Not sure which platform to focus on? Digital or Print?**

Why not use **both** as we provide **free of charge** benefits for both platforms which you get **from day 1**.

VIEW / DOWNLOAD OUR FREE **DIGITAL PUBLICATIONS** FROM OUR WEBSITE!

**FEB**

**JAN**

**DEC**

**TVHOL**

**TURBOFIX**  
Est. 1992  
"We are the leaders in the turbocharging field"

**TURBOFIX**  
Est. 1992  
"We are the leaders in the turbocharging field"

Are you **paying too much** for your current artwork in a publication?  
Are you **paying too much** for your current online marketing?

We have such **competitive prices** that you won't need to look anywhere else.

Spending money on artwork designs and unnecessary features you don't need?

Transport & Construction™ has its **own designers** who can put artwork together for you, **free of charge.**

The **only price you pay** is the amount on the contract which is **non-binding.** No surprises!

**Don't hesitate to contact us. We are the answer you are looking for.**  
**Contact Tom Lloyd at 044 382 1606**  
**or send an Email to [finance@lloydsgroup.net](mailto:finance@lloydsgroup.net)**

**TRANSPORT & CONSTRUCTION™**

WE PLACE BUYERS AND SELLERS TOGETHER

29 YEARS WORKING FOR YOU

March 2024  
Volume 30 No. 03

Price: R.S.A 823.00  
Neighbouring State 846.00  
[www.transportandconstruction.co.za](http://www.transportandconstruction.co.za)

**INFORMATION ON:**  
New and Used Construction Equipment,  
Cranes, Forklifts, Mining Equipment,  
Parts and Services, Material Handling,  
Trucks, Trailers, Busses and  
Engineering Equipment

**C.T.C. PLANT COMPANY (PTY) LTD**  
SINCE 1985

**OUR SERVICE:**  
We also have several trailers on hand to meet the many needs of our customers, this includes:

- Step Decks
- Weld Decks
- Folding Goosenecks
- Low Bed Trailers

**TRANSPORT SPECIALISTS OF EARTHMOVING PLANT & EQUIPMENT**

**WHY CHOOSE US ?**  
We have a mixed fleet of nine Mercedes-Benz and MAN trucks that consists of three- and four- axle trucks and a crane truck.

**SPECIALISED TRANSPORT SERVICES**  
We offer heavy equipment transport services to all major cities across South Africa, including Johannesburg, Pretoria, Durban, and Kimberley.

**GUARANTEED FAST & RELIABLE**

Tel: 011 868 5130  
 Fax: 086 634 7904  
 Cell: 071 684 5784

# MZANTSI TRANSMISSIONS



- BELL
- TEREX
- DESMOND
- HITACHI
- DAEWOO
- ZF
- ALLISON
- CLARK
- FUNK

**We offer specialised transmission  
 repairs for heavy duty & on  
 highway machines**



info@gearboxes.me  
 6 van der Bijl  
 Alrode South  
 Alberton

**WE OFFER DYNO TESTING ON ZF TRANSMISSIONS**

[www.transportandconstruction.co.za/digital-publications/](http://www.transportandconstruction.co.za/digital-publications/)



**VIEW OUR  
 INTERACTIVE  
 DIGITAL  
 PUBLICATION**



044 382 1606

• [finance@lloydsgroup.net](mailto:finance@lloydsgroup.net) [www.transportandconstruction.co.za](http://www.transportandconstruction.co.za)

# Your Biggest Fan

*(Radiator Fan Problems)*

Your vehicle's engine makes a lot of heat when it's powering you down the road, so it needs a way to get rid of that energy. That's why your vehicle has a cooling system, complete with a radiator and one or two radiator fans, also called cooling fans. Those fans make sure air keeps moving across the radiator so that the heat stored in the coolant can be dissipated outside when the vehicle is stopped or not traveling fast.

Radiator fans can develop problems and can stop working properly or stop working altogether. Some signs to look for? If you're driving slowly and idling and you see your temperature gauge moving toward the red or hot zone, that could spell trouble. Another thing you may notice when a radiator fan is failing is that there may be a loud noise coming from the engine compartment.

There are two types of radiator fans. One is mechanically connected to the engine and uses the engine's rotational energy to turn it. The other is an electric fan and is the type used in most newer vehicles. In the electrical type, one of the components, such as a relay or fuse, may fail, causing the fan to stop turning. In the mechanical type, since it's driven by a pulley/belt mechanism, one of those components may break or stop working properly. A clutch can wear out or a belt may slip or break.

When your cooling fan isn't working properly, it may cause your engine to overheat which could lead to expensive damage. That's why it's important to make sure you visit your service facility if you notice any of these symptoms. A technician is trained to diagnose the problem and make sure your radiator fan is doing its job. When it comes to your vehicle, your radiator fan really is your biggest fan.



# MACHINERY CONTRACTORS

## MC HYDRAULIC OPERATED QUICK COUPLER

### FEATURES:

- Front & Rear Safety Lock
- Safe Release Curl to Open
- Lighter but Durable
- Save 25% of operational time
- Low Maintenance



4: Engaging plate extends  
3: Front lock closes  
2: Curl to Position  
1: Hook the Bucket

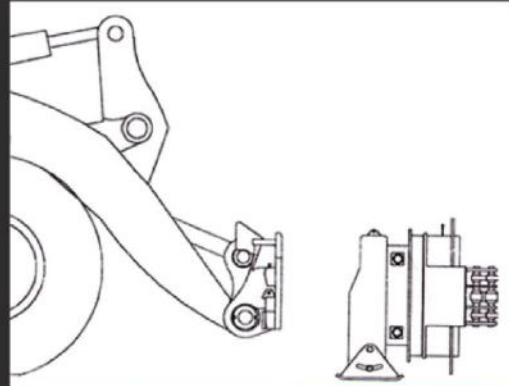

IT DRASTICALLY REDUCES DOWNTIME TO ONLY 2 TO 3 MINUTES TO CHANGE BETWEEN ATTACHMENTS WITH THE MC QUICK COUPLER SYSTEM INSTALLED.



info@machinerycontractors.co.za    Tel: +27(0)12 250 3534    Tel: +27(0)12 250 8956



# MACHINERY CONTRACTORS

## TYRE HANDLERS

### CONTROL FUNCTIONS INCLUDE:

- Forward and backward telescopic extension of approximately 380 mm for quick and accurate extraction and control of the tyre and rim from the studs of the truck.
- Level Rotation of 180°.
- Side Shifting (left and right) to a maximum of 320 mm.
- 360° Front Wheel station rotation.
- The MC Tyre Handler is fitted with front rotation motors, delivering 17 000 N·m torque.

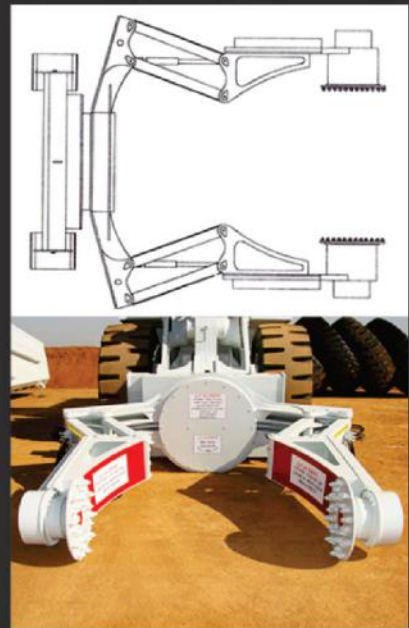

**MACHINERY CONTRACTORS PROVIDES A PROVEN SOLUTION TO YOUR TYRE HANDLING NEEDS.**



info@machinerycontractors.co.za    Tel: +27(0)12 250 3534    Tel: +27(0)12 250 8956

# 10

## Simple Construction Site Safety Rules

*Construction sites are dangerous places to work. Follow these 10 simple construction site safety rules to keep yourself, and others, safe. From wearing your PPE, to following procedures, you can help make your site a safer place to work, and prevent accidents.*

### 1. Wear your PPE at all times

When you enter the site, make sure you have the PPE you need. PPE is important, it's your last line of defence should you come into contact with a hazard on site.

### 2. Do not start work without an induction

Each site has its unique hazards and work operations. No two sites are exactly the same. Make sure you know what is happening so that you can work safely.

### 3. Keep a tidy site

Construction work is messy. Slips and trips might not seem like a major problem compared to other high-risk work happening on the site, but don't be fooled.

### 4. Do not put yourself or others at risk

Actions speak louder than words. Especially on construction sites where one wrong move could put you in harm's way. Set a good example, think safe and act safely on site.

### 5. Follow safety signs and procedures

Follow construction safety signs and procedures. These should be explained to you in your induction (rule number 2). Your employer should ensure a risk assessment is carried out for your activities.



## 6. Never work in unsafe areas

Make sure your work area is safe. Know what is happening around you. Be aware.

## 7. Report defects and near misses

If you notice a problem, don't ignore it, report it to your supervisor immediately. Fill out a near-miss report, an incident report, or simply tell your supervisor.

## 8. Never tamper with equipment

If something's not working, or doesn't look right, follow rule number 7 and report it. Don't try and force something, or alter something, if you're trained to or supposed to.

## 9. Use the right equipment

One tool does not fit all. Using the correct tool for the job will get it done quicker, and most importantly, safer. Visually check equipment is in good condition and safe to use before you start.

## 10. If in doubt, ask

Unsure what to do? Or how to do something safely? Or you think something is wrong? Stop work, and ask. It takes 5 minutes to check, but it might not be so easy to put things right if things go wrong.





SPEC-CAST WEAR PARTS

*Trusted to deliver*

## EXTREME IMPACT AND ABRASION RESISTANT WEAR PLATE

**ENGINEERED TOUGH & DUCTILE, LIKE NO OTHER WEAR PLATE**

**QT-PLUS® wear life is 3 to 5 times longer than AR400 commodity wear steel.**

QT-PLUS® proprietary chemistry and unique thermal heat-treating process produces a premium quality, severe impact and abrasion resistant plate unmatched in the industry. This incredibly tough and through-hardened steel with extraordinary ductility, is produced with tightly controlled carbon levels for ease of weldability, and excellent formability.



## EXTREME ABRASION RESISTANT CHROMIUM CARBIDE OVERLAY PLATE

**INCREDIBLE HARDNESS, UNRIVALED PERFORMANCE**

CHROME WELD™ 600 is a 600 Brinnell chromium carbide plate that is ideal for surfaces requiring high levels of abrasion resistance.

CHROME WELD™ 600 typical hardness ranges from 58-62 Hrc based on weld deposit thickness. The surface of the plate exhibits numerous hairline cracks which are a natural stress relieving phenomenon that enable it to be formed, bent, and rolled without damage.



**TRUCK BED LINERS · DOZER LINERS · CHUTES · SCREENS  
BUCKET WEAR STRIPS · IMPACT WEAR PLATES · HOPPER LINERS**

### JHB HEAD OFFICE

+27 11 396 1717/13  
info@spec-cast.co.za  
11 Elgin Street, Pomona,  
Kempton Park, Johannesburg

### www.spec-cast.co.za

**MIDDELBURG**  
+27 13 813 1413  
middelburg@spec-cast.co.za  
6 Jaspis Street  
Middelburg, Mpumalanga

**NORTHERN CAPE**  
+27 53 010 1304  
northerncape@spec-cast.co.za  
Section C3, Portion of Farm Waterraad  
Kathu, Northern Cape

Follow us:



# THE ADVANTAGES OF DISC BRAKES

## FOR HEAVY-DUTY TRUCKS

Brakes appear as one of the crucial factors when considering the specifications of heavy-duty trucks. A lot of individuals get confused between disc and drum brakes. Well, disc brakes on heavy-duty trucks come with several advantages.

The cost of owning a disc brake is lower compared to a drum brake, which is why it represents a better value to the user. Talking about the performance, it is usually resistant to fading. There is the minimal impact of contamination due to rust, water, or dirt. Many users get rid of brake adjustment issues, as the calipers are self-adjusting.

For many truck owners, disc brakes are a better option due to less maintenance. In a drum brake, there are nine to 12 moving parts. Conversely, there are fewer moving parts on disc brakes, reducing the need for maintenance. This feature ensures longer life.

When it comes to inspection or replacement, friction pads are easily accessible. For cleaning purposes, one can easily reach the calipers.

You might have noticed there is no need to remove the hub and rotor when the entire caliper is removed for maintenance purposes.

Thanks to these features, many individuals opt for disc brakes on heavy-duty trucks.

A lot of heavy lifting is involved when drum brakes are replaced with air disc brakes. It can be time taking and dangerous for the mechanics.

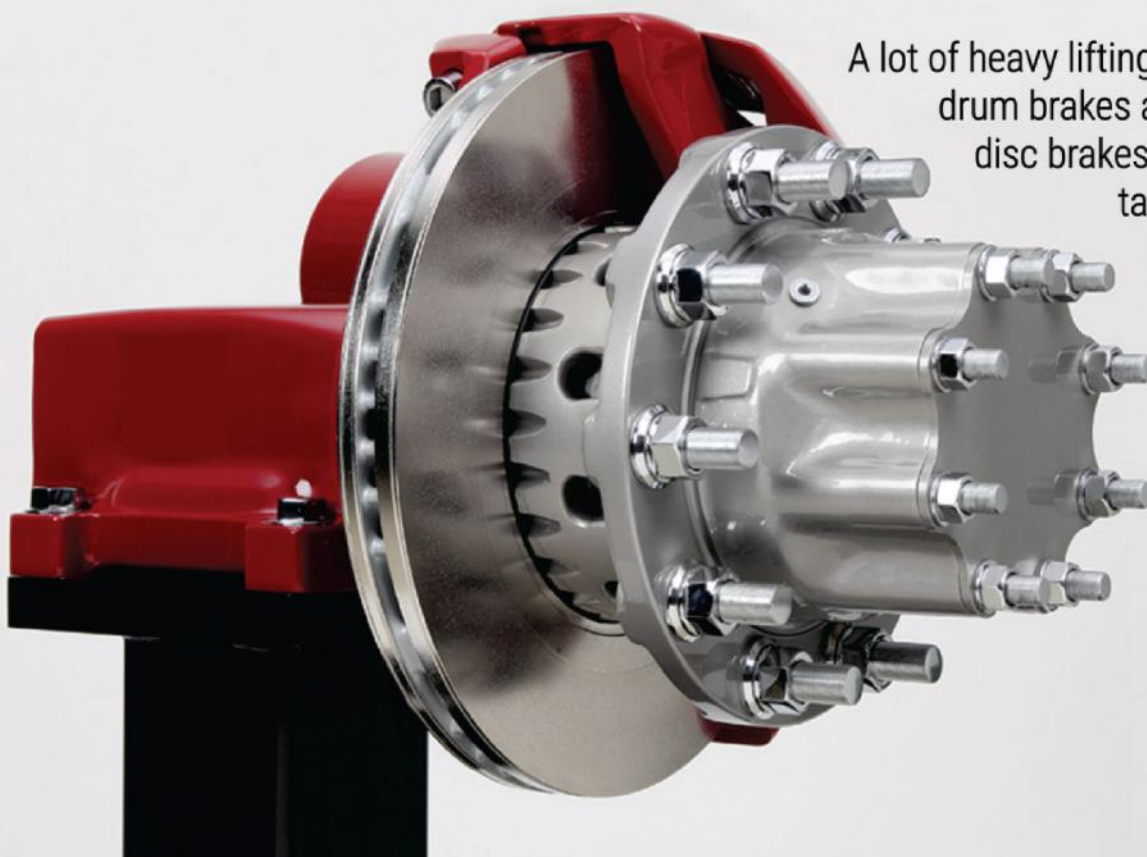



# VIEW OUR INTERACTIVE DIGITAL PUBLICATION



044 382 1606 • finance@lloydsgroup.net

www.transportandconstruction.co.za



AUTOMOTIVE • HEAVY DUTY  
• CONSTRUCTION AGRICULTURAL  
• MINING • GENERATORS

SERVICE AND YOUR DOWNTIME IS OUR PRIORITY.  
WE WILL ENDEAVOUR TO FIND WHAT YOU NEED!

## 25 YEARS CUMMINS EXPERIENCE FOR YOUR CUMMINS ENGINE COMPONENTS

NOW IN STOCK



CONTACT US FOR UNBELIEVABLE PRICING AND SERVICE

- Mid-tier range on 4/6 B and 6C Series
- QSB 6.7 | QSC | QSL | ISB | ISF | ISC | L8.9/L9/L10 Series
- Selected ISX15 | QSX15 | NTA855/855 | N14 | M11
- New ISF2.8/ISF3.8 | QSF2.8/QSF3.8 | B3.3 | QSB 4.5

PLUS A WIDE RANGE OF 8PK BELTS AND FILTERS

### CARRADINE VARKEVISSER

Tel: 011 976 1242 | Cell: 060 525 9943  
Cell: 063 753 6466  
Email: sales@jumanje.co.za



Follow us on Facebook:  
www.facebook.com/jumanje4u



# SUMMER TRUCK DRIVERS:

## Tips to Beat the HEAT

Whether you've recently completed truck driving school or are a seasoned truck driver, you'll want to make sure you take the proper precautions to beat the heat while on the road during the summer months. Follow the truck driving safety tips below and you'll be much more comfortable, happy and safe.

### Stay Hydrated

It's easy to forget to drink water while on the road, but it's extremely important in order to stay properly hydrated - particularly during the hottest months of the year.

Keeping a couple of bottles of water next to you while you're driving will serve as a constant reminder and make it practical for you to drink water throughout the day.

### Keep Tires Inflated

In the higher temperatures of the summer, the chance of tire blowouts increases. Under-inflated tires can further increase the risk for blowouts, so you'll want to be sure you check that your tires are properly inflated before you drive.

### Check Your Brakes Regularly

Check your brakes before you start your drive because higher temperatures can result in a loss of friction when the brake parts can't absorb any more heat.

### Protect Yourself from the Sun

Spending several hours a day driving means you will have a lot of sun exposure. Don't forget to follow sun safety tips like wearing sunscreen and wearing long sleeves.

### Be Aware of Crowded Roads

Roads tend to be a lot more crowded during the summer months with families taking vacations and a lot more people having time off work. Heavy traffic volume presents more dangers for truck drivers, so you'll want to be extra alert and aware of other vehicles on the road.



edcomps@mweb.co.za / 011 615 6391  
011 616 6150

## VISION

We see ourselves as one of the leading compressor company's in South Africa. Our goal is to further extend our reach around South Africa and the rest of Africa as we continue to build the company to ensure that we can provide old, and new companies, with the best possible service as we build long - term relationships with our clients.

## SERVICES

Edmar Agencies are committed to providing our customers in our unique market with the care and attention that you deserve. Our customers always come first and our knowledgeable sales and workshop staff are on hand to provide top quality service and aftersales technical support.

**OWNER**  
Jason Humphries:  
082 951 1611  
edmarag@mweb.co.za

**SALES**  
Manny Silva:  
082 447 1333  
edcomps@vodamail.co.za  
Martin Makhanye:  
076 262 7449  
martin@edmar.co.za

[www.edmar.co.za](http://www.edmar.co.za)

322 Jules Street, Malvern, Johannesburg 2094



**EDMAR AGENCIES**  
The Driving Force In Air Brake Compressors



[www.transportandconstruction.co.za/digital-publications/](http://www.transportandconstruction.co.za/digital-publications/)



VIEW OUR  
INTERACTIVE  
**DIGITAL**  
PUBLICATION



044 382 1606 • [finance@lloydsgroup.net](mailto:finance@lloydsgroup.net)

[www.transportandconstruction.co.za](http://www.transportandconstruction.co.za)



# DEUTZ DIESELPPOWER

National phone number: 08610 33889 / 08610 DEUTZ

Tel: +27 (0)11 923-0600  
Fax: +27 (0)11 923-0687  
E-mail: info@deutz.co.za  
Website: www.deutz.co.za



Stick with the authorised **DEUTZ** Product and Service experts for all your service and genuine\* **DEUTZ** spare parts and engines.

\*Please be aware of non-genuine engines & parts being passed off as DEUTZ. If in any doubt please contact us. Please contact us about our product range & services. We can help you get the best out of your DEUTZ engines.

The engine company.



**TRANSPORT & CONSTRUCTION™**



044 382 1606



finance@lloydsgroup.net

## OUR BENEFITS

- Monthly Publications - Printed & Digital Digests
- Free & Professional Artwork Designs
- Social Media Exposure
- Weekly Newsletter Exposure
- Daily Client Promotional Emails
- Personalised Company Page On Our Website
- Vendorship On Our Online Shop

AND MORE...

www.transportandconstruction.co.za



# Disinfecting Heavy Equipment.

*With the growing concern of cleanliness we are constantly being reminded to wash our hands, wipe down commonly touched surfaces, and avoided touching our face. If you operate heavy machinery, you should also be regularly sanitizing the equipment after operating. Unfortunately, this isn't as easy as spraying some bleach and calling it good. Knowing how to properly clean and disinfect the cab in your heavy equipment is extremely important in order to reduce the risk of infection for you and your team without damaging pricey equipment.*

## **What To Use:**

*The interior components of the cab like touch screens, switches, and upholstery require special treatment. Use one of these EPA-approved disinfectants, that are designed to kill the First Time Around, while also being safe for interiors. If possible it is best to choose a sanitizer that is contactless, removing the need to wipe down surfaces after applying. Most consumer products usually come ready to use, but some products may have to be diluted and properly ventilated. We recommend checking your manufacture guidelines prior to choosing a disinfectant. If no manufacturer guidance is available, consider the use of alcohol-based wipes or sprays containing at least 70% alcohol to disinfect. CDC recommends ensuring a contact time of at least one minute. We highly recommend not using products containing bleach to clean your cab.*





## **Before Disinfecting:**

Prior to cleaning your cab, follow proper safety guidelines by using gloves and a face mask. Since the virus can spread asymptotically, you do not want to skip this step as it is the best way to ensure the surfaces are not re-infected while you are cleaning. It is also recommended that you allow the cab to ventilate for a few minutes before entering and after cleaning, as the life span of the virus in the air particles confined in a cab is unknown.

## **How to Properly Sanitize Your Equipment:**

When you are ready to start cleaning you will need to wipe down any surfaces that are dirty or covered in dust with soap and water before applying disinfecting products. Once the cab is cleaned you can spray your sanitizing solution on commonly touched surfaces such as the handles, floor mats, windows, touchpads, knobs, seat buckle, and the steering wheel. On the exterior of your machine spray down the handles, latches, gas cap, and grab bars.

Your equipment has certain surfaces that should be cleaned with careful consideration. When cleaning electronic consoles and display interfaces, it is best to use a disinfecting wipe or spray your solution on a microfiber cloth to wipe down the keyboards and displays. This may seem like an extra step, but it will ensure that no dried residue interferes with the functionality and performance of your equipment. When cleaning the upholstery, check that your product is free of bleach and or safe on leather/ vinyl to prevent damage.

**Once you have finished sterilizing your machine, wash your hands before touching any other surface to prevent spreading anything you might have come in contact with. For more information, The CDC has provided guidelines and tips for "Cleaning and Disinfection for Non-emergency Transport Vehicles."**



## SPARES FOR AFRICA

011 397 5276 (6 lines)  
011 397 2129 (Fax)  
082 655 2301 (Cell)

info@getspares.co.za  
sales@getspares.co.za

We carry a range of genuine spares, as well as aftermarket spares imported from the United Kingdom.

Our comprehensive stock of fast moving parts has an approximate value of R8 million. We are able to supply the majority of customer requirements regarding stock.

We cover the length and breadth of South Africa with well established distributors in Kwa-Zulu Natal and the Western Cape and we conduct over the border business on a regular basis. We also have a branch in Port Elizabeth with future branches in the pipeline.



**Easily Able To Send  
Airfreight Parcels.**



**We Offer  
Competitive Discounts.**



**We Frequently Export  
To Zimbabwe, Botswana  
And Mozambique**

**We Appreciate That Down Time Is Expensive And We Do Our Utmost To Ensure  
That Our Customers Have Their Parts With Minimum Delay.**

# Quality Service

## The Secret To Our Success

The Seat Connection provides a complete repair, rebuild or new seating solution for all commercial and industrial vehicles.

Our products are used in trains, trucks, buses, mining and game viewing vehicles, as well as construction equipment and other specialised vehicles. Our services not only include new seat sales, but the complete mechanical rebuild of operator and passenger seats, while our inhouse upholsterer takes care of your upholstery needs. (terms & conditions apply)

With over 30 years of service to the transport industry, our solid background, expertise and product knowledge, makes us a leading auto seat specialist.



**IRSI  
AIR NTS**



**KAB  
411**



**KAB  
525**



**The seat  
CONNECTION**



TheSeatConnection    +27 11 452 6802    info@seatconnection.co.za    www.seatconnection.co.za

**TRANSPORT &  
CONSTRUCTION™**



**044 382 1606**



**finance@lloydsgroup.net**

# OUR BENEFITS

- Monthly Publications - Printed & Digital Digests
- Free & Professional Artwork Designs
- Social Media Exposure
- Weekly Newsletter Exposure
- Daily Client Promotional Emails
- Personalised Company Page On Our Website
- Vendorship On Our Online Shop

**AND MORE...**

[www.transportandconstruction.co.za](http://www.transportandconstruction.co.za)



WHEN IS IT TIME TO

# Replace Your Bulldozer

**N**ow that you have an idea of the components inside your bulldozer, it is time to look at how they are doing. If there are any worn parts or pieces that may be difficult for you to replace then this might indicate when it is time to sell and purchase a new dozer instead of rebuilding yours.

One way to help prolong the life of your bulldozer is through scheduled maintenance. A lot of this depends on how often you use your machine and what type of terrain it works in, but a general rule would be to service your dozer every 250 hours.

Additional Considerations for Lifespan Dozers, like excavators, have an undercarriage that must be maintained. The underside of a bulldozer, for example, supports a heavy machine and is subject to its working conditions.



Make sure the dozer you're buying has an undercarriage suited for the job you'll be doing with it.

Hauling dirt on flat ground, for example, isn't going to put nearly as much strain on the underside of your vehicle as heavy or abrasive materials handling in a landfill; crawling over various things and difficult terrain.



This will clean out all the dirt and grime that has built up over time as well as top up all the fluids and check the tightness of screws and bolts. While some of these factors may be difficult to determine, they are important ones to consider when deciding on a replacement.

The distinction between standard and heavy-duty undercarriages has a purpose. Following ideal handling and operation procedures, such as restricting reverse movement, may also assist to avoid damage the underside.



# ACS.

# AUTO COOLING SOLUTIONS CC

- Fan Blades • Replacement Units
- Fan Clutches
- Universal Electric Fans (12V - 10", 12", 14", 16")  
(24V - 12", 14", 16") etc



**For Most Makes of: Motor Vehicles,  
Pick Ups, Trucks, Busses, Heavy Duty  
Equipment, Off Road Vehicles**

**ELAINE PIENAAR**

**Tel: +27 (0) 21 982 7114 / 7116**

**Cell: +27 (0) 84 681 2513**

**Email: autocooling@telkomsa.net**

**Web: www.autocoolingsolutions.co.za**

**www.autofans.co.za**

**Unit 6 & 7 • 14 Tarentaal Crescent, Okavango Park, Brackenfell, 7560**



**TRANSPORT &  
CONSTRUCTION**

**"Stopping advertising to save money is like  
stopping your watch to save time." - Henry Ford**

**Placing Buyers & Sellers In Touch For 29 Years**

*Paramount Customer Focus / Smarter Product Promotion / Innovation For Progress*

**www.transportandconstruction.co.za**



**Buy direct from factory  
for the best prices!**

64 Tannery Road, Hamilton,  
Bloemfontein, South Africa  
PO Box 35643 Faunasig 9325

**Contact person: Johan Britz**

Tel: (051) 435-4752 or 435-4450

Fax: (051) 435-4753

e-mail: [permas@mweb.co.za](mailto:permas@mweb.co.za)

Our polyurethane seating is designed for comfort and durability. It can withstand the rigors of the most demanding environments and has high resistance in tear strength, abrasion, grease and water.

### **THE PRODUCTS TARGET MAINLY THE FOLLOWING SECTORS:**

- Transport
- Construction
- Mining
- Earthmoving equipment industries
- Forklift or handling industry
- Forestry
- Military
- Agriculture





# **RHINO**

## **Excavator Hammers cc**



We Also Do Plant Hire



Hire: 082 887 8636 | Sales: 071 670 8707 / Office: 074 922 2382  
[sales@rhinohammers.co.za](mailto:sales@rhinohammers.co.za) | [hire@phplant.co.za](mailto:hire@phplant.co.za) | [www.rhinoattachments.co.za](http://www.rhinoattachments.co.za)

**Repairs to JCB engines  
 Transmissions and Axles**

**DO YOU OWN ONE OF THESE?**

Contact us for all your JCB Parts and service requirements.

# **JCB**

**Parts & Service Specialists**

FULLY EQUIPPED WORKSHOP FACILITIES  
 AND FIELD SERVICE VEHICLES

[www.csmorritt.co.za](http://www.csmorritt.co.za)

**Tel: 072 614 7044**

**Fax to Email 086 667 1386**

# **CS MORRITT CC**

Wydan Business Park No 58 Road 5 Unit No 4 Brentwood Park BENONI



**PROFESSIONAL | PERSONAL | QUALITY | EXPERIENCED SERVICES**

# Bell ReMan Parts & Components

for **JCB**  
Backhoe Loaders



Get a range of re-manufactured components with the same performance and warranty 'as new' for peace of mind at a fraction of the cost.

**BELL**  
South Africa

Proudly selling  
& supporting

**JCB**

Email: [reman@bellequipment.com](mailto:reman@bellequipment.com) • [www.bellequipment.com](http://www.bellequipment.com) • FOLLOW US ON    



# MID PLANT SERVICES

NEW EXCAVATOR PARTS, COMPONENTS AND REPAIRS

THE ALTERNATIVE SUPPLIER FOR DOOSAN, HYUNDAI, VOLVO  
AND MOST CHINESE EXCAVATORS SOLD IN SOUTH AFRICA.



:+27 (0)11 967 0055

:+27 (0)11 967 0060



: SALES@MIDPLANT.COM



: 273 3RD AVENUE, BREDELL,  
KEMPTON PARK, 1619



: WWW.MIDPLANT.COM

## Your Complete Source for Earthmoving Equipment Parts and Service

Mid Plant Services is a leading supplier of new, refurbished, and cost-effective excavator parts and components for the earthmoving, contract mining, quarrying, and construction industries. We cater to a wide range of equipment, including:

**Korean brands: Daewoo/Doosan, Hyundai, Volvo**

**Chinese brands**

**Japanese brands: Hitachi, Komatsu, CAT, Sumitomo**

**Our extensive network of international suppliers and experienced team of parts specialists (with over 30 years of industry experience) allow us to offer:**

**Comprehensive selection: We stock a wide variety of components, including rotating groups, seals, engine parts, undercarriage parts, hydraulic cylinders, track adjusters, buckets, pumps, motors, swing reductions, final drives, and more.**

**Quality and expertise: Our team understands the importance of quality and provides exceptional service to ensure your equipment operates at its best.**

**Competitive pricing: We offer cost-effective solutions to meet your budget requirements. Mid Plant Services is committed to being your one-stop shop for all your earthmoving equipment needs.**

FOLLOW US ON:



# Adendorff machinery mart

## QUALITY TOOLS & MACHINERY



# GENERATORS

ALL YOUR MACHINERY REQUIREMENTS UNDER ONE ROOF

SHOP ONLINE @ [WWW.ADENDORFF.CO.ZA](http://WWW.ADENDORFF.CO.ZA)

## COMPRESSORS



MAC AFRIC 150L  
DIESEL  
COMPRESSOR

**R26 950**  
COMPRE706

## CONSTRUCTION EQUIPMENT



15 HP BACKHOE DIGGER  
WITH 250MM  
BUCKET

**R85 950**  
MDIGBH001

## GENERATORS



MAC AFRIC 6.5 KVA  
STANDBY PETROL  
GENERATOR

**R8995**  
MGENER553



MAC AFRIC 16KVA  
(16KW-230V)  
SILENT DIESEL GENERATO

**R98 950**  
MGENER016



MAC-AFRIC CD 630  
12/24 V BATTERY  
BOOSTER/CHARGER

**R2995**  
GCHARG600

## WATER PUMPS



MAC AFRIC 50MM  
5.5HP PETROL DRIVEN  
WATER PUMP

**R2995**  
MPUMPS552



MAC AFRIC 3" DIESEL  
POWERED  
CLEAN WATER PUMP

**R10 950**  
MPUMPS008



MAC AFRIC MIG 500i  
INVERTER MIG/MA  
WELDING MACHINE KIT

**R34 950**  
EWELDM500

## CONSTRUCTION EQUIPMENT



MAC AFRIC HZR-70  
PETROL PLATE  
COMPACTOR

**R11 995**  
MCOMPT070

# BRANCHES COUNTRYWIDE

PRICES VALID 15 JANUARY 2024 THEREAFTER SUBJECT TO CHANGE WITHOUT PRIOR NOTIFICATION. PRICES INCLUDE 15% VAT. E&OE

# 5 TIPS

## For Getting The Most Out Of Your Construction Equipment

*Whether you are purchasing brand new or used construction equipment, ensuring you are getting the most out of each piece is the next crucial step. Although many companies may want to forge ahead and utilize all equipment right away, careful considerations is needed to make sure you are taking full advantage of all equipment items. This article outlines the steps you must take to ensure that your company is using equipment profitably and efficiently. Through these five tips, find ways to proactively extend the life of your construction equipment and machinery.*

### Maintain a Good Relationship With Suppliers

The dealer who sold you your equipment isn't just a sales person, he or she is a wealth of knowledge about your new investment. If questions arise about the operation, maintenance, or anything else regarding the care of your equipment, a good relationship with your supplier means you will always have someone knowledgeable to call for an answer. Similarly, if you encounter any problems with your machinery, that same supplier can probably help you troubleshoot and get you back on the job site. Ultimately, your supplier is an incredibly valuable resource when it comes to understanding the ins and outs of how your equipment works. Forming a long-lasting relationship will only bode well in the future, if you need to purchase other pieces going forward.

### Properly Train Employees

Good employee training can make a huge difference in extending the life of your equipment. When operators aren't 100% sure about how to use the various controls, the potential for unnecessary wear and tear – or even worse, equipment damage – is significantly higher. By putting your employees through a training program or providing one-on-one instruction, you create well informed team members who will use your machines properly. Occasional training refreshers are also a good idea to keep your employees well-versed on procedures and keep your equipment running smoothly.



## Store Equipment Properly

While construction equipment is designed to withstand all sorts of rugged conditions, it's not designed to be left out in jobsites, or exposed for very long periods of time. Making an effort to keep your machinery in a proper storage facility will go a long way in preventing the possibility of damages. Temperature-related stresses are often avoidable if equipment is stored properly. Although the circumstances may dictate that equipment is to be left out over a short period, try your best to avoid this. Moreover, if a piece of equipment, machinery or vehicle has done its job on a project, make it a priority to store it away in case of any unpredictable accidents that may occur on a busy jobsite. Similarly, cleaning equipment regularly, especially before prolonged periods of storage, will help to keep it in good working condition and have it ready for your next job.

## Keep Up With Regular Maintenance

All machinery needs regular preventative maintenance to operate well. Check with your supplier (see first tip on keep up a good relationship with suppliers) to get your specific equipment's maintenance schedule, and then perform that maintenance in full every time it is due. Regular maintenance often includes oil analysis and changing, cleaning residues, and replacing worn out components. It is easy to forget about this or prolong it until later, but keeping your equipment well maintained is essential. By not being diligent and leaving equipment maintenance overdue, you may experience irreversible damage which can shorten its life cycle.



# Precision Diesel

Precision Diesel strives for quality and excellent workmanship

www.precision-diesel.com



022 482 1493 / 022 482 3296

+27 022 487 3117

zwang@telkomsa.net



## Supplier of diesel fuel injection systems.

Our injectors provide superior performance and durability.



### DIESEL FUEL INJECTION & TURBO SPECIALISTS

Repair & Maintenance to all makes of diesel fuel pumps, injectors and turbochargers  
Complete range of authorised parts for diesel fuel injection systems and turbochargers for all makes of trucks, bakkies and passenger vehicles.



18B Schoonspruitweg, Malmesbury, Western Cape, South Africa, 7299

TRANSPORT & CONSTRUCTION™



044 382 1606



finance@lloydsgroup.net

## OUR BENEFITS

- Monthly Publications - Printed & Digital Digests
- Free & Professional Artwork Designs
- Social Media Exposure
- Weekly Newsletter Exposure
- Daily Client Promotional Emails
- Personalised Company Page On Our Website
- Vendorship On Our Online Shop

AND MORE...

www.transportandconstruction.co.za



**JOHANNESBURG (Head Office)**  
459 Flower Close  
Sam Green Road  
Tunney Ext.. 9, Germiston  
Tell: 011 822 2221 / 011 010 9000



**PINETOWN**  
Unit 7 Techni Park  
29 Hollclimb  
Westmead, Pinetown  
Tel: 031 700 5905 / 031 656 3000

## FOR ALL YOUR TRANSMISSION AND DIFFERENTIAL NEEDS

Truck Gearbox and Differential components  
are within easy reach of all repair  
and service facilities.

- ★ Rockwell Parts
- ★ Eaton Parts
- ★ Fuller Parts
- ★ ZF Parts
- ★ Volvo Parts
- ★ Scania Parts
- ★ Mercedes-Benz Parts



[info@advancedtransmissions.co.za](mailto:info@advancedtransmissions.co.za)  
[sales@advanceddbn.co.za](mailto:sales@advanceddbn.co.za)

# 8 WAYS TO CONTROL EROSION AT CONSTRUCTION SITES

Erosion control is one of the biggest concerns for many large construction projects. Multiple factors can cause erosion, and every situation calls for specific solutions based on the site and the severity of the problem. Controlling erosion is important not just for preserving the construction site and protecting the new structure but also for minimizing the environmental impact that the project has on the surrounding area. Erosion control measures can add significantly to the project cost, and manufacturers are continually developing innovative products to minimize cost as well as environmental impact.

## 01 Articulated Concrete Blocks

Articulated concrete blocks are revetment systems that can be constructed in a wide variety of shapes and thicknesses. The blocks form a grid of interconnected units used for erosion control on embankments of waterways and manmade drainage channels.

## 02 MSE Walls

Mechanically stabilized earth (MSE) walls have replaced many traditional concrete retaining walls in recent decades. MSE walls offer several advantages over conventional reinforced concrete walls, including ease and speed of installation. This system also is adaptable to a variety of sites.

## 03 Turbidity Barriers

Turbidity barriers are used to prevent soil erosion and migration of contaminants in water. They are typically made of a geotextile membrane that floats and is anchored to the bottom of the water body with weights. Sometimes turbidity barriers are used for supplemental sediment control.

## 04 Geotextiles

Geotextiles are commonly used to control erosion and improve soils over which roads, embankments, pipelines, and earth-retaining structures are built. Depending on the application, geotextiles may have an open mesh weave, a warp-knitted structure, or a closed fabric or nonwoven surface. The specific type of geotextile used is based on several criteria, including separation, filtration, drainage, reinforcement, sealing, and protection.



## 05 French Drains

A French drain is a system of underground piping—called drain tile—that channels surface and groundwater to an exit point. The drain tile may also be perforated to allow water to seep into the soil below the tile, while excess water travels to the exit point. French drains are installed with a slope of about 1 inch of drop per 10 feet of horizontal run.



## 06 Soil Nails

Soil nailing provides a resisting force against slope failures and offers relatively quick installation. The basic installation procedure involves drilling into the soil and placing a series of steel bars—the nails—deep into the earth. The nails are capped at the surface with a facing to create a barrier similar to a retaining wall. Soil nails also can be driven into the soil and may or may not be grouted in place after installation.

## 07 Riprap

Riprap is a commonly used method to protect soil from erosion in areas of concentrated runoff. Riprap is a layer of very large stones interlocked together to act as a barrier on slopes that are unstable because of seepage problems or areas that are receiving a large, concentrated flow. This method is commonly used to minimize erosion of lake shores and riverbeds. Riprap often is installed over a synthetic geotextile membrane to prevent the soil from moving through the riprap.

## 08 Dust Control Methods

Dust control measures apply to any construction site where there is the potential for air and water pollution from dust traveling across the landscape or through the air. Dust also represents the potential for wind erosion. Common methods for dust control in soil include misted water, silt fences (and similar barriers), and polymer additives.

145 Lamp Road, Wadeville, Germiston



# GFA

OUR QUALITY COMPARES 100%  
TO ANY OEM SPARE  
MANUFACTURES

Gears for Africa 011 824 2017

**MANUFACTURE OF SPIRAL BEVEL GEARS NOW AVAILABLE**



**PETREL**  
INTERNATIONAL  
ESTD 1947

*Gears for Africa* products include all types of gears, sprockets, splines and related products for industrial and heavy duty equipment and practically all applications related to power drive systems:

- *Bevel Gears* • *Spur Gears* • *Worm Gears*
- *Helical & Internal Helical Gears*
- *Crown gears* • *Internal & External Splines*

**Petrel International Official Distributors of: Braden/Paccar Winch**

**BRADEN CARCO Gearmatic**

# PACCAR WINCH

**CROWN WHEEL AND PINION, PLANETARY, SUN AND RING GEARS  
FINAL DRIVE GEARS, DIFF HOUSINGS SPIDER CROSS KITS, SPIRAL BEVEL GEARS**

**FOR THE MINING, RAIL, HEAVY EARTH MOVING, CONSTRUCTION  
AND AGRICULTURAL INDUSTRIES**



083 657 0522

carl@gearsforafrica.co.za  
www.gearsforafrica.co.za

Tel: 011 824 2017  
Fax: 011 420 3314

# YOUR TRUSTED PARTS SUPPLIER

FOR EARTHMOVING AND AGRICULTURAL MACHINERY

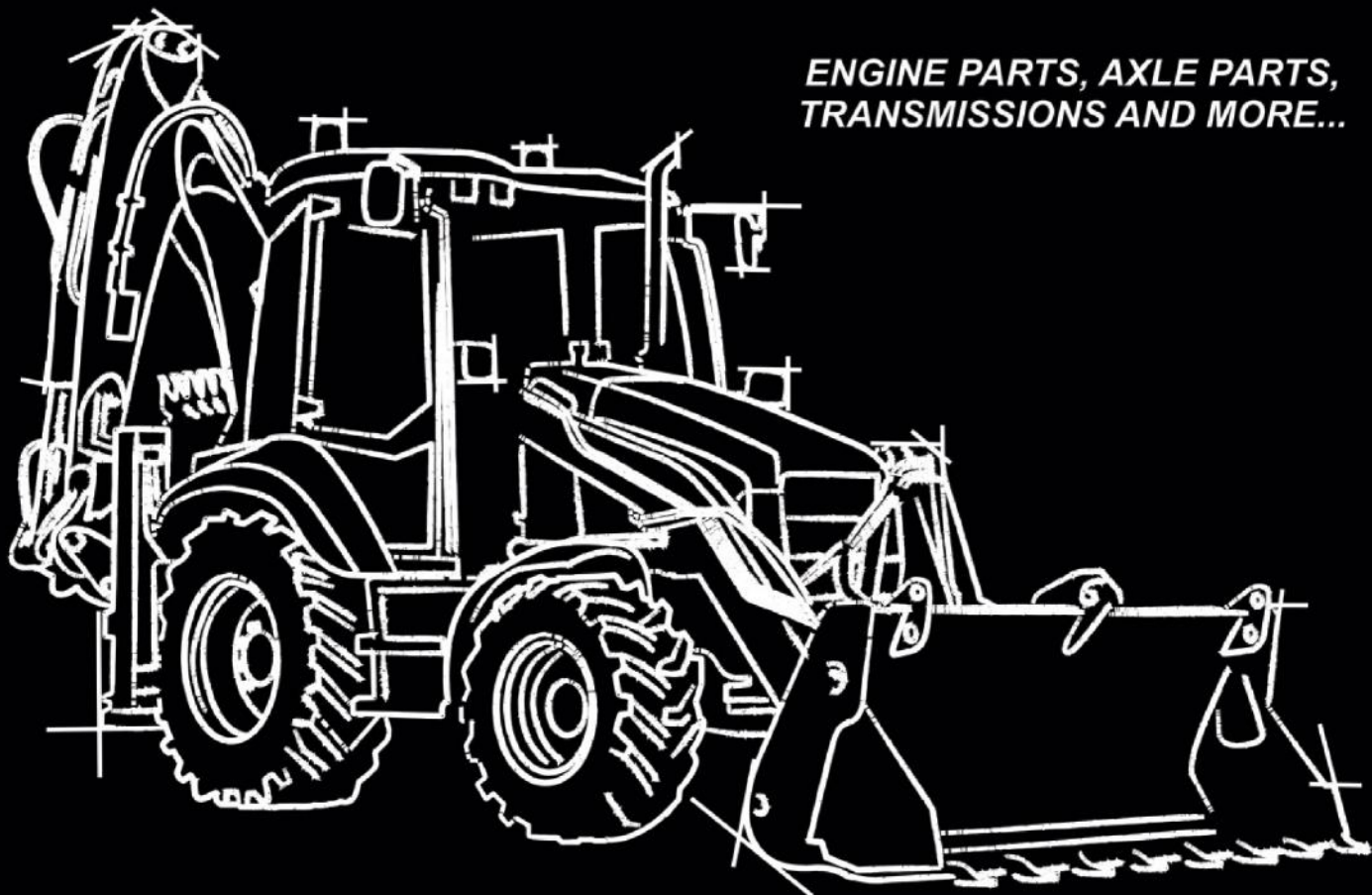

*ENGINE PARTS, AXLE PARTS,  
TRANSMISSIONS AND MORE...*



**CARRARO** Spare Parts Authorized Dealer

*We supply original & quality replacement parts!  
Covering more than 130 brands!*

SINCE 2013



Agri Earth

**www.LNE-AgriEarth.com**

+27 (0)861 888 008 | +27 (0)83 327 3237 (A/H)

LNE@LNE-AgriEarth.com

 @LNEAgriEarth



**CARRARO**

Spare Parts  
Authorized Dealer

# DUMPERS

- and their  
DIFFERENCES -



**O**therwise known as articulated dump trucks, these are generally the largest of the earth-moving plant types. Capacities can vary from 5 m<sup>3</sup> to 30 m<sup>3</sup>. They are the most suitable option for sites where large amounts of material needs to be transported over distances both on and off site.

The vehicles have heavily-plated bodies and are hydraulically operated which allows for quick discharge. There are a wide range of dumpers available with differing carrying capacities and discharge options (front, side or elevated tipping). The most common options are:



## Standard dumper

Diesel powered dumper with gravity tipping skip. Heaped capacity ranges from 0.7-1.5 m<sup>3</sup>.

## Swivel skip dumper

Hydraulic tipping skip mounted on 180-degree slewing turntable.



## Highway dumper

Much larger dumper used to transport spoil off site. The rear tipping skip is hydraulically operated, and the usual heaped capacity is 10 m<sup>3</sup>





**SHIN LI**  
**TRADING** ©



*We Specialise in  
Japanese & Korean  
Earthmoving Spares*

## ENGINE SPARES

Liner Kits, Gasket Kits, Valves & Guides,  
Water Pumps, Oil Pumps, Crank & Cam Shafts,  
Engine Bearings & Bushings



**Mitsubishi**  
**Komatsu**  
**Doosan**  
**Nissan**  
**Isuzu**  
**Hino**

## HYDRAULIC PARTS

### Kawasaki Pumps

New and Complete



### Final Drives

20 Ton Excavator  
Final Drive Parts  
& Complete Units



### Komatsu Gear Pumps

Transmission Pumps  
Steering Pumps  
Main Pumps



### Kawasaki Rotating Groups

K3V and K5V Series  
Inner Parts  
Rotating Groups  
Seal Kits



### Komatsu Cylinders

Complete Cylinders  
Seal Kits



**WWW.SHINLITRADING.CO.ZA**

Email:  
sales2@shinlitrading.co.za  
sales4@shinlitrading.co.za  
sales5@shinlitrading.co.za

Address: 67 High Road  
Bredell A/H  
Kempton Park  
011 396 1081





**BELL  
SERVICE &  
PARK BRAKE**

**BELL  
TRANSMISSION  
& DIFF DISCS**

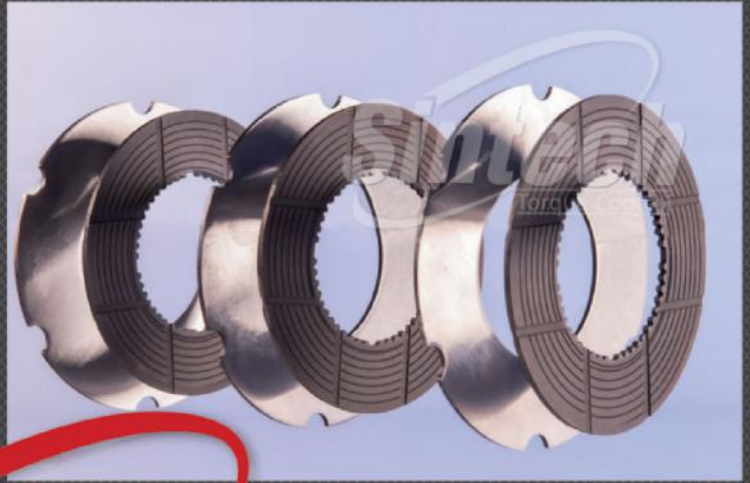

**Sintech**

**ORIGINAL  
EQUIPMENT  
SUPPLIER**



[www.sintech.co.za](http://www.sintech.co.za)

+27 (0)11 823 2359



Contact Details:  
 Tel: +2711 918 1397/8  
 Fax: 086 241 0044  
 Inquiries: sales@slpsa.co.za  
 After Hours: 082 453 1079

We don't do "cheap"  
 we do QUALITY!



**ENGINE**

- Lubricating system
- Fuel system
- Fuel system, gas
- Inlet/Outlet system
- Cooling system
- Engine controls
- Ignition & control system
- Other engine, EGR system

**POWER TRANSMISSION**

- Clutch, torque converter
- Gear box hydraulic
- Gear box
- Hydrostatic system
- Propeller shaft
- Rear axle, CE front axle
- Differentials
- Power take-off
- Other gear box

**BRAKES**

- Wheel brake
- Hydraulic brakes
- Parking brake
- Air brakes
- Trailer brake control
- Brake other

**FRAME, SPRINGS, WHEELS AND HUBS**

- Frame
- Suspension
- Frame joint
- Axle suspension
- Shock absorbers, anti-roll bar
- Wheel & hub

**BEE Level 4**

**New range of Scania parts available**

**Swedish Manufactured Replacement Parts for Volvo Mining, Truck, Bus, Penta Marine and Industrial applications.**



# Must-Have Tools

## For Your Garage Workshop

---

Your garage is where you take all your large-scale projects, but you cannot build well without the proper instruments. Here are the must-have tools for your garage workshop.

### The Workbench

No high-quality work is easy to do without a stable workbench. Whether you build one yourself or find one elsewhere, your workbench is your workstation for all garage workshopping. Before you select your workbench, anticipate your needs and projects. Will you need to mount wood-cutting instruments, or do you need wide space for large items? Make sure you factor in the dimensions of your garage and the area where you'll likely need to complete projects.

### Common Toolset

A proper toolset will give you the breadth you desire for every project, though you may need specialized power tools for the depth of ability. Common toolsets typically include tape measures, hammers, utility knives, saws, levels, screwdrivers, wrenches, and pliers. You can choose a large toolset if you need many types of each tool, or you can opt for a small set of bare essentials. Do your research on the durability and application of the items before you choose a set.





## Power Tools

Power tools both accelerate and simplify many workshopping processes, so you must have the equipment that relates to the work you'll do consistently. For example, if you focus on woodworking, you'll want a circular saw handy to cut cleaner and faster edges. Or, if you plan on assembling larger items, you'll want a cordless power drill with an assorted set of drill bits.

These bits will range from screwdriver bits to hole-boring bits. You can also put an electric lock pick tool to use if you construct doors or even lock yourself out of your own home from the garage. Like the common toolset, you'll want a specific power toolset depending on your projects.

## Cleaning Supplies

Garage workshopping is a dirty business, often leaving wood shavings and rusty tools in its wake. You will want quality cleaning supplies to maintain a pristine working environment. Keep a shop vacuum handy to suck up your dust from workshopping. This heavy-duty vacuum handles much larger volumes of debris than your typical home vacuum cleaner. You'll also want a set of steel, copper, and brass cleaners, along with steel-bristled brushes and degreasers, to both clean and polish your tools. With the proper care, you can extend the lifetime of your instruments well beyond normal.

Stock up on these must-have tools for your garage workshop so you can complete every project with precision and passion.

Workshopping is an excellent hobby, but only with the right tools in hand.



# Adendorff machinery mart

## QUALITY TOOLS & MACHINERY



# GENERATORS

ALL YOUR MACHINERY REQUIREMENTS UNDER ONE ROOF

SHOP ONLINE @ [WWW.ADENDORFF.CO.ZA](http://WWW.ADENDORFF.CO.ZA)

## COMPRESSORS



MAC AFRIC 150L  
DIESEL  
COMPRESSOR

**R26 950**  
COMPRE706

## CONSTRUCTION EQUIPMENT



15 HP BACKHOE DIGGER  
WITH 250MM  
BUCKET

**R85 950**  
MDIGBH001

## GENERATORS



MAC AFRIC 6.5 KVA  
STANDBY PETROL  
GENERATOR

**R8995**  
MGENER553



MAC AFRIC 16KVA  
(16KW-230V)  
SILENT DIESEL GENERATO

**R98 950**  
MGENER016



MAC-AFRIC CD 630  
12/24 V BATTERY  
BOOSTER/CHARGER

**R2995**  
GCHARG600

## WATER PUMPS



MAC AFRIC 50MM  
5.5HP PETROL DRIVEN  
WATER PUMP

**R2995**  
MPUMPS552



MAC AFRIC 3" DIESEL  
POWERED  
CLEAN WATER PUMP

**R10 950**  
MPUMPS008



MAC AFRIC MIG 500i  
INVERTER MIG/MA  
WELDING MACHINE KIT

**R34 950**  
EWELDM500

## CONSTRUCTION EQUIPMENT



MAC AFRIC HZR-70  
PETROL PLATE  
COMPACTOR

**R11 995**  
MCOMPT070

# BRANCHES COUNTRYWIDE

PRICES VALID 15 JANUARY 2024 THEREAFTER SUBJECT TO CHANGE WITHOUT PRIOR NOTIFICATION. PRICES INCLUDE 15% VAT. E&OE

# Personal Protective Equipment (PPE)

**S**afety is a major concern for any laborer. Accidents are extremely prominent in the construction industry due to the absence or inadequate use of Personal Protective Equipment (PPE). PPE is equipment that protects workers against health or safety risks on the job and reduces employee exposure to hazards. The dangers can be anything from slippery wet floors to loose falling debris. PPE includes items such as protective helmets, eye protection, high-visibility clothing, safety footwear, safety harnesses and, sometimes, respiratory protective equipment.

It is no question that this line of work presents many risks. Understanding the benefits of PPE as well as liability insurance for your business can be tremendously impactful in reducing the risk of injury and claims in the construction sector.

## The Head

Hard hats are commonly utilized on construction sites. They are designed to protect against flying or falling objects that would otherwise significantly harmed the worker. Some hard hats come with face shields and earmuffs for further protection.

One of the most important things to remember is that hard hats must fit well in order to work appropriately. Make sure that your team all has well-fitting hard hats, or their head protection will not be adequate.



## Eyes and Face

Proper eye and face protection is extremely important. Safety goggles and full face shields are available to protect the eyes and face. This equipment is especially vital in specific fields such as metal work, wood-work, hot-work and air-tool operations.



## Respiratory

Respiratory protection should never be underestimated. It is truly essential on sites where toxic substances are present. This protection was created to protect you from dust, fumes, paint spray, pesticides and other harmful substances that could cause permanent damage. Respirators will likely be needed when sufficient ventilation is not attainable.

## Hands and Skin

Construction work normally requires a lot of hand use. About 150,000 hand injuries are reported every year. Occupational skin diseases are as regular as dermatitis, skin cancers, and other skin injuries. Infections are the second most common type of occupational disease.

Because of this, glove usage is critical to protect the skin. Common PPE glove types are rubber, cut-resistant, chainsaw and heat-resistant gloves. Take advantage of gloves to avoid hazards involved with chemical, glass, sheet metal, electricity work.

## Hearing

Approximately 82% of occupational hearing loss cases are those working in the manufacturing sector, so ear protection is a must.

Earplugs and earmuffs are common hearing protection tools. Note that earmuffs are effective in reducing high-frequency noise, while earplugs should be used for reducing low-frequency noise.



# TRANSPORT & CONSTRUCTION ONLINE SHOP

[www.transportandconstruction.online](http://www.transportandconstruction.online)

TRANSPORT & CONSTRUCTION™ Online Shop provides you with a vast range of heavy equipment, parts and services. Our mission is to connect suppliers and buyers by supplying a user friendly and diverse online platform.

*Here you will find all your favourite brands in one place.*

## ONLINE SHOP BENEFITS ARE ONLY AVAILABLE TO TRANSPORT & CONSTRUCTION™ CLIENTS

We make it **effortless** for our clients to manage their **products** and **services**. Suppliers can easily **add multiple items** of their choice in their **personal dashboard** and start selling in no time!

Online Shop is a 24/7 online marketplace around the globe selling a wide variety of products.

### Supplier Benefits

- Growing your business with **unique** and **powerful solutions**.
- Providing **full support** with complete customer satisfaction.

**We are dedicated to providing you and your company assurance of successful marketing and digital exposure. You can contact us at any time to find out how we can assist you.**

044 382 1606

[finance@lloydsgroup.net](mailto:finance@lloydsgroup.net) - [www.transportandconstruction.co.za](http://www.transportandconstruction.co.za)

ONLINE SHOP™

## 4 SIMPLE STEPS TO BECOME A VENDOR:

[www.transportandconstruction.online](http://www.transportandconstruction.online)

**Step 1:** Go to our Online Shop website and click on BECOME A VENDOR.

**Step 2:** Fill in the form with your correct details.

**Step 3:** You will receive an email confirming that your information is being processed. There will also be a link to your account that will only be activated once it is approved. Finally you will receive another email stating that your account is activated!

**Step 4:** Click on the link provided to access your account and start selling!

Becoming an Online Shop Vendor gives you the option of having **full control over your OWN Online Store**. But we also give our clients the option of us managing their stores given that they provide us with the information needed.

**Adding** your company products/services to Online Shop has never been so easy! It will give your company the benefit of traffic generated by our **No1 Google Ranking Website**, placing you ahead of your competitors.

We do not allow any payments to be made through the website. Vendors are able **to interact directly** with their buyers and get notified every time a new order for a specific product arrives.

Vendors can also set up their own **Store Policies** such as Shipping Policy, Refund Policy and Cancellation/ Return/ Exchange Policy if applicable to their company.



**Contact Tom @ 044 382 1606 or 082 894 1672 to start promoting your business with us!**

**“We have the answer  
to **Increasing Your Sales.**”**

Promoting **YOUR COMPANY** with Transport & Construction communicates important information, and creates awareness of your goods & services, it is essential to attaining your **objectives and goals.**

*Planning*

Your Company's Marketing Strategy?

**STOP MISSING OUT**

*on our top of the line*

**Promotional Services!**

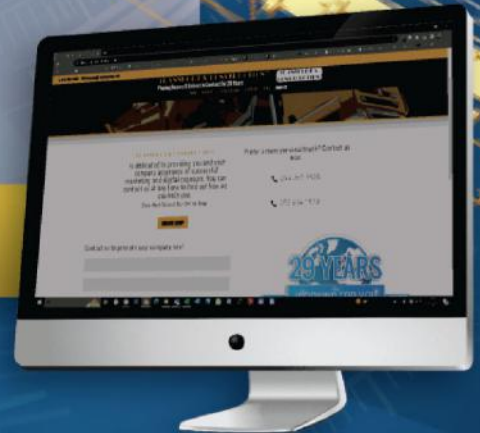

[www.transportandconstruction.co.za](http://www.transportandconstruction.co.za)

**TRANSPORT &  
CONSTRUCTION™**



Placing Buyers & Sellers In Touch For **29 Years**

Paramount Customer Focus / Smarter Product Promoting / Innovation For Progress





AS ONE OF OUR **VALUED CLIENTS** WE WANT  
TO OFFER YOU OUR BEST RATES!



VISIT OUR DIGITAL PUBLICATIONS

## Benefits Include:

- Exposure in our monthly Printed and Digital Publications.
- **Daily Promotional Email** exposure and **Weekly Newsletter** currently emailed to 45 000 recipients,
- Access as a vendor on our new and greatly improved **Online Shop**,
- **Permanent Company Page** on our website, - **Social Media Exposure**
- **FREE Artwork** Designed by our professional graphic designers.

These added services are **FREE OF CHARGE** to clients promoting their goods & services in Transport & Construction.



"Stopping advertising to save money is like stopping your watch to save time." - Henry Ford





Mike's Mark  
inspire · create · flow

www.mikesmark.com

2024  
HAPPY NEW YEAR

DONE FOR YOU "WEBSITE-IN-A BOX" LOW COST SUBSCRIPTION PRODUCTS TO GET YOU INTO FLOW!

# From Zero to Launch!

All done for you online solutions that leave you free from all the tech and management. Why not let us take care of the whole solution for you, for a low monthly subscription cost?

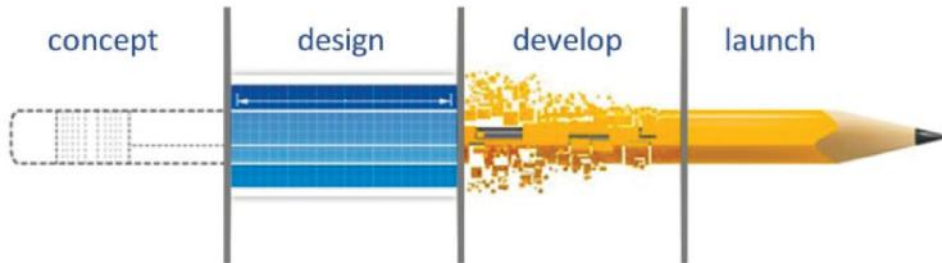

*professional · efficient · dynamic · seamless*

Fully Packaged and Managed Subscription Products!

Latest design and functionality trends that are responsive on all devices.



*We have designed websites for*

**TRANSPORT & CONSTRUCTION™**

transportandconstruction.co.za • transportandconstruction.online



mike@mikesmark.com



082 563 1231



SPEC-CAST WEAR PARTS

*Trusted to deliver*

**Specialising in the supply of:**

- Ground Engaging Tools
- Undercarriage Components
- Track Frame Repairs & Components
- Dragline & Heavy Mining Wear Parts
- Abrasion Resistant Wear Steel

**Ground Engaging Tools and Wear Protection**

**SERIOUSLY TOUGH**



**Undercarriage Components**

VemaTRACK



**KEEPING YOU MOVING**



**Track Frame Repairs, Rebuilds and Service Exchange Units**

**TRACK FRAMES**

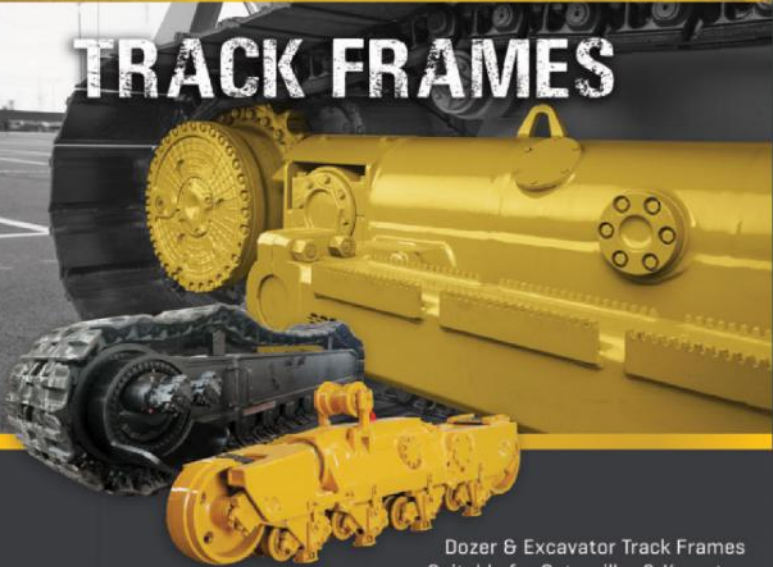

Dozer & Excavator Track Frames  
Suitable for Caterpillar & Komatsu

**Abrasion Resistant Wear Steel**

**PROVEN PROTECTION**



**JHB HEAD OFFICE**

+27 11 396 1717/13  
info@spec-cast.co.za

**www.spec-cast.co.za**

MIDDELBURG  
+27 13 813 1413  
middelburg@spec-cast.co.za

NORTHERN CAPE  
+27 53 010 1304  
northerncape@spec-cast.co.za

Follow us:



Manufacturer's names, numbers, symbols and descriptions are used for reference purposes only and it is not implied that any part listed above is the product of the manufacturers.

# TRANSPORT & CONSTRUCTION™

## Index

### Agricultural/Forestry Equipment

AGRICO .....	29
All Terrain Tyres .....	32
AT Vehicles & Equipment .....	30
CMS Products .....	32
CTC Plant Company .....	FC/IC/38
Equipment Spare Parts .....	26 - 27
H.V.R Turbos .....	29
Jumanje Diesel Parts .....	16/50
LNE Agri Earth (Pty) Ltd .....	17/73
ME ENG Supplies .....	31
Perma Seating .....	18/60
SPEC-CAST Wear Parts .....	48/89
Synergy WWL .....	33
TVH PARTS SA .....	15/39

### Airbrakes/Brakes/Airbags

ATSA Compressors .....	20
Denver Truck Spares .....	14
Edmar Agencies .....	10/52
Get Spares for Africa .....	8/56
KG Backhoe .....	00/00
Sintech .....	13/76
SLP South Africa .....	19/77
Synergy WWL .....	33

### Attachments

AGRICO .....	29
All Terrain Tyres .....	32
AT Vehicles & Equipment .....	30
CS Morrill .....	11/61
CTC Plant Company .....	FC/IC/38
EHD Components .....	28
Machinery Contractors .....	2-3/44-45
Synergy WWL .....	33
Tempo Attachments .....	IC

### Civils/Concrete Equipment

All Terrain Tyres .....	32
AT Vehicles & Equipment .....	30
CMS Products .....	32
CS Morrill .....	11/61
CTC Plant Company .....	FC/IC/38
Synergy WWL .....	33

### Construction/Earthmoving Equipment

All Terrain Tyres .....	32
AT Vehicles & Equipment .....	30
Bell Equipment .....	4/62
EHD Components .....	28
CMS Products .....	32
CS Morrill .....	11/61
CTC Plant Company .....	FC/IC/38
Denver Truck Spares .....	14
Equipment Spare Parts .....	26 - 27
Get Spares for Africa .....	8/56
Jumanje Diesel Parts .....	16/50
KG Backhoe .....	00/00
Komanco .....	21
LNE Agri Earth (Pty) Ltd .....	17/73
Machinery Contractors .....	2-3/44-45
ME ENG Supplies .....	31
Mid Plant Services .....	24/63
Perma Seating .....	18/60
Pex Hydraulics (Pty) Ltd .....	1/34
Rhino Hammers .....	10/61
Sintech .....	13/76
SPEC-CAST Wear Parts .....	48/89
Synergy WWL .....	33
Vortex Transmissions .....	7

### Crushing/Mining Equipment

All Terrain Tyres .....	32
AT Vehicles & Equipment .....	30
Bell Equipment .....	4/62
CMS Products .....	32
CTC Plant Company .....	FC/IC/38
Denver Truck Spares .....	14
Equipment Spare Parts .....	30 - 33
Machinery Contractors .....	2-3/44-45
ME ENG Supplies .....	31
Perma Seating .....	18/60

Pex Hydraulics (Pty) Ltd .....	1/34
Rhino Hammers .....	10/61
Shin Li Trading cc .....	9/74
Sintech .....	13/76
SPEC-CAST Wear Parts .....	48/89
Synergy WWL .....	33

### Dismantled Machines

CTC Plant Company .....	FC/IC/38
Denver Truck Spares .....	14
Synergy WWL .....	33

### (Drive-train) Clutches/Gearboxes Transmissions

Denver Truck Spares .....	14
E & A Spares .....	21
Equipment Spare Parts .....	26 - 27
Gears for Africa .....	12/72
Get Spares for Africa .....	8/56
KG Backhoe .....	00/00
ME ENG Supplies .....	31
Mid Plant Services .....	24/63
Mzantsi Transmissions .....	22/42
Shin Li Trading cc .....	9/74
Sintech .....	13/76
SLP South Africa .....	19/77
Vortex Transmissions .....	9
Synergy WWL .....	33

### Engine

AGRICO .....	29
All Terrain Tyres .....	32
AT Vehicles & Equipment .....	30
Cargo Crankshaft Rebuilding .....	22
Denver Truck Spares .....	14
Deutz DieselPower .....	25/53
E & A Spares .....	20
EHD Components .....	34
Equipment Spare Parts .....	26 - 27
Get Spares for Africa .....	8/56
H.V.R Turbos .....	29
Jumanje Diesel Parts .....	16/50
KG Backhoe .....	00/00
Komanco .....	21
LNE Agri Earth (Pty) Ltd .....	17/73
Mid Plant Services .....	24/63

Pex Hydraulics (Pty) Ltd .....	1/34
Shin Li Trading cc .....	9/74
SLP South Africa .....	19/77
Synergy WWL .....	33

### Forklifts

All Terrain Tyres .....	32
AT Vehicles & Equipment .....	30
H.V.R Turbos .....	29
ME ENG Supplies .....	31
Synergy WWL .....	33

### Fans/Cooling Systems

Auto Cooling Solutions .....	7/59
Denver Truck Spares .....	14
Get Spares for Africa .....	8/56
Komanco .....	21
Synergy WWL .....	33

### Fuels/Lubricants

Denver Truck Spares .....	14
Deutz DieselPower .....	25/53
Jumanje Diesel Parts .....	16/50
Synergy WWL .....	33

### Generators/Compressors

Adendorff Machinery - 66-67/82-83 .....	
ATSA Compressors .....	20
All Terrain Tyres .....	32
AT Vehicles & Equipment .....	30
Deutz DieselPower .....	25/53
EHD Components .....	28
H.V.R Turbos .....	29
Synergy WWL .....	33

### Hydraulic Equipment

All Terrain Tyres .....	32
AT Vehicles & Equipment .....	30
EHD Components .....	28
Get Spares for Africa .....	8/56
Komanco .....	21
Machinery Contractors .....	2-3/44-45
ME ENG Supplies .....	31
Mid Plant Services .....	24/63
Pex Hydraulics (Pty) Ltd .....	1/34
Rhino Hammers .....	10/61



# TRANSPORT & CONSTRUCTION™

## Index

Shin Li Trading cc.....	9/74	Pex Hydraulics (Pty) Ltd.....	1/34	Rhino Hammers.....	10/61
Sintech.....	13/76	Precision Diesel.....	11/68	Sintech.....	13/76
SLP South Africa.....	19/77	Rhino Hammers.....	10/61	Synergy WWL.....	33
Synergy WWL.....	33	Shin Li Trading cc.....	9/74	The Seat Connection.....	25/57
<b>Lifting Equipment</b>					
All Terrain Tyres.....	32	Sintech.....	13/76	Turbofix.....	6 - 7/94
AT Vehicles & Equipment.....	30	SLP South Africa.....	19/77	TVH PARTS SA.....	15/39
Perma Seating.....	18/60	SPEC-CAST Wear Parts.....	48/89	Vortex Transmissions.....	9
Machinery Contractors 4/5/46.....	47	Synergy WWL.....	33	<b>Starters</b>	
ME ENG Supplies.....	31	The Seat Connection.....	25/57	CTC Plant Company.....	FC/IC/38
TVH PARTS SA.....	15/39	Turbofix.....	6 - 7/94	Denver Truck Spares.....	14
Synergy WWL.....	33	TVH PARTS SA.....	15/39	EHD Components.....	28
<b>Machine Hire</b>					
CTC Plant Company.....	FC/IC/38	Vortex Transmissions.....	9	Mid Plant Services.....	24/63
TVH PARTS SA.....	15/39	<b>Seats/Accessories</b>			
Synergy WWL.....	33	All Terrain Tyres.....	32	Synergy WWL.....	33
<b>Parts</b>					
Advanced Transmissions.....	23/69	AT Vehicles & Equipment.....	30	<b>Transport/Trucks/Trailers</b>	
AGRICO.....	29	Machinery Contractors.....	2-3/44-45	AGRICO.....	29
ATSA Compressors.....	20	Perma Seating.....	18/60	All Terrain Tyres.....	32
All Terrain Tyres.....	32	Synergy WWL.....	33	AT Vehicles & Equipment.....	30
AT Vehicles & Equipment.....	30	The Seat Connection.....	25/57	CTC Plant Company.....	FC/IC/38
Auto Cooling Solutions.....	7/59	<b>Services</b>			
Bell Equipment.....	14/64	AGRICO.....	29	Denver Truck Spares.....	14
Cargo Crankshaft Rebuilding.....	22	ATSA Compressors.....	20	E & A Spares.....	20
CS Merritt.....	11/61	All Terrain Tyres.....	32	H.V.R Turbos.....	29
CTC Plant Company.....	FC/IC/38	AT Vehicles & Equipment.....	30	Perma Seating.....	18/60
Denver Truck Spares.....	14	Auto Cooling Solutions.....	7/59	Synergy WWL.....	33
Deutz DieselPower.....	25/53	Bell Equipment.....	14/64	<b>Turbos</b>	
E & A Spares.....	20	Cargo Crankshaft Rebuilding.....	22	CTC Plant Company.....	FC/IC/38
Edmar Agencies.....	10/52	CS Merritt.....	11/61	Denver Truck Spares.....	14
EHD Components.....	28	CTC Plant Company.....	FC/IC/38	Mid Plant Services.....	24/63
Equipment Spare Parts.....	26 - 27	Denver Truck Spares.....	14	Precision Diesel.....	11/68
Gears for Africa.....	12/72	Deutz DieselPower.....	25/53	Synergy WWL.....	33
Get Spares for Africa.....	8/56	E & A Spares.....	20	Turbofix.....	6 - 7/94
Jumanje Diesel Parts.....	16/50	Edmar Agencies.....	10/52	<b>Tyres</b>	
KG Backhoe.....	00/00	EHD Components.....	28	All Terrain Tyres.....	32
Komanco.....	21	Equipment Spare Parts.....	26 - 27	AT Vehicles & Equipment.....	30
LNE Agri Earth (Pty) Ltd.....	17/73	Gears for Africa.....	12/72	Bell Equipment.....	14/64
Machinery Contractors.....	2-3/44-45	KG Backhoe.....	00/00	Denver Truck Spares.....	14
ME ENG Supplies.....	31	Komanco.....	21	Get Spares for Africa.....	8/56
Mid Plant Services.....	24/63	Machinery Contractors.....	2-3/44-45	Synergy WWL.....	33
Perma Seating.....	18/60	ME ENG Supplies.....	31	TVH PARTS SA.....	15/39
		Mid Plant Services.....	24/63		
		Mzantsi Transmissions.....	22/42		
		Pex Hydraulics (Pty) Ltd.....	1/34		
		Precision Diesel.....	11/68		



# TURBOFIX

"We are the leaders in the turbocharging field"

## Facts for Customers

We know that there are customers that believe you can't repair a Turbocharger due to the bad experience with poor workmanship in Turbocharger Companies.

Quality Turbocharger repairs are infinitely possible, as long as the correct equipment & knowledge is used. Cheaper Turbochargers are not always the same quality, due to inferior quality & low cost parts. (Price vs. Quality)

**We strive to supply the best Quality.**



"There is no substitute for quality & service"