



**SUPPLITECH LTD.**

**PRODUCT BROCHURE**  
**May 2023**

Tel:01524 237911  
[www.Supplitech.com](http://www.Supplitech.com)

- 3 Surefix XL Unlined Clip
- 4 Surefix XL Rubber Lined Clip
- 5 316 Stainless Steel Unlined Clip
- 6 316 Stainless Steel Lined Clip
- 7 Heavy Duty Surefix HD Unlined & Lined Clip
- 8 SUP100 - Split Band
- 9 Phenolic Pipe Support
- 10 ROCKTHERM Stone Wool Pipe Support
- 11 Threaded Rod
- 12 SUP 104 Standard & Extended 'U' Bolt
- 13 SUP170 - Filbow Clamp  
SUP203 - Bow Nut  
SUPBH - Ball Hanger
- 14 SUP240 G/M/B - Munsen Rings  
SUP241 G/M/B - School Board Clips  
SUP242 G/M/B - Backplates
- 15 SUP Strut Systems  
Cantilever Arms  
Square Plate Washers  
Channel Nuts
- 16 SUP Strut Brackets
- 17 Untied EPDM Pump Flexibles
- 18 Tied EPDM Pump Flexibles
- 19 Screwed EPDM Pump Flexibles
- 21 FA3 Stainless Steel Pump Flexibles
- 23 Air & Dirt Separators
- 25 Dosing Pots
- 26 Inertia Bases

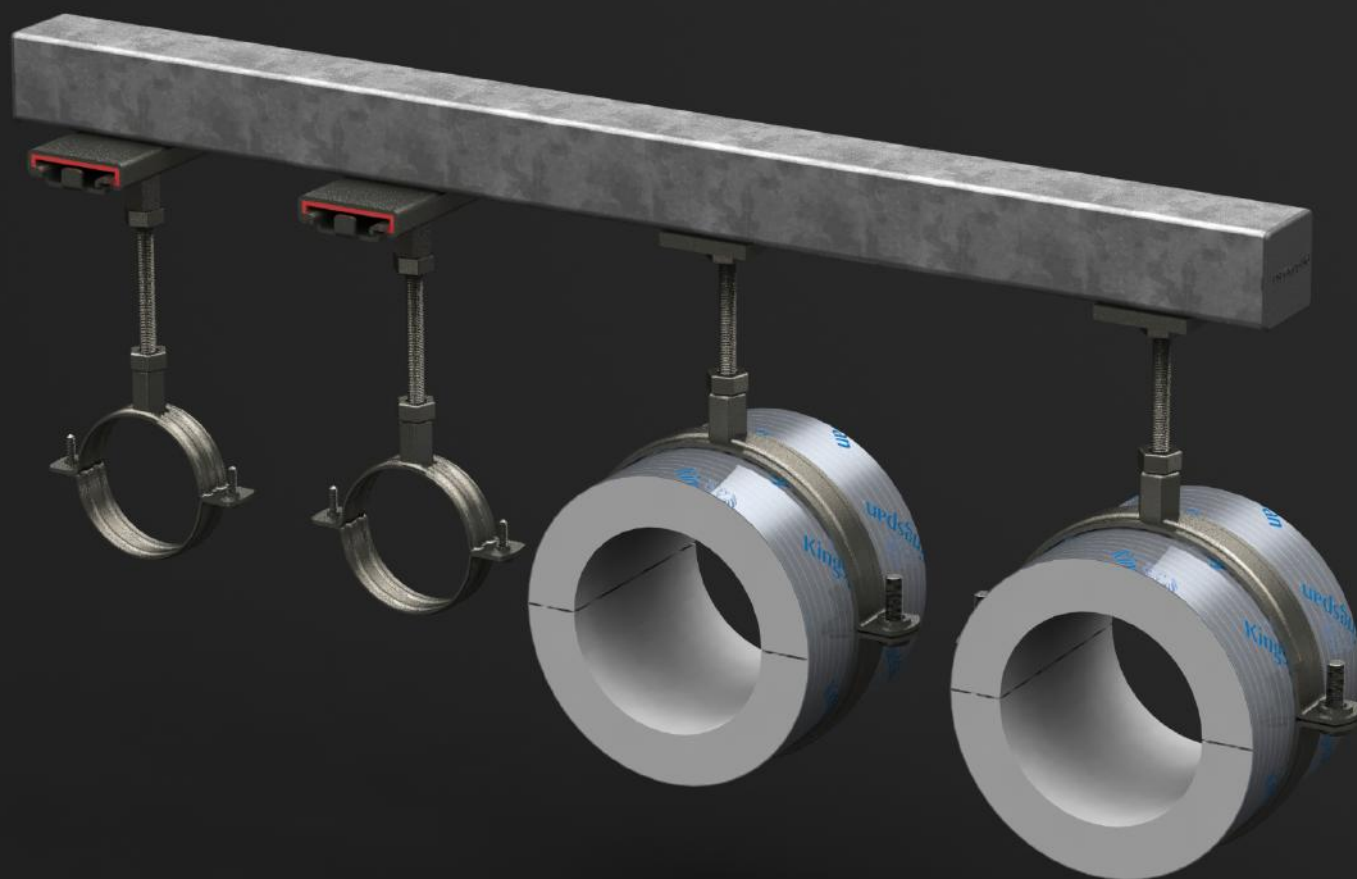

# Surefix XL Unlined Clip

## For Steel Pipes & Insulated Pipe Supports

### Construction

Mild Steel  
BZP Finish

### For Use With

Steel & Cast Iron Tubes  
Insulated Pipe Supports



Pipe Size	Grip Range (mm)	Boss Type	Screw (mm)	Material (mm)
1/2"	19-23	M8/M10	M5 x 25	1 x 20
22mm	23-28	M8/M10	M5 x 25	1 x 20
3/4"	26-30	M8/M10	M5 x 25	1 x 20
1"	32-35	M8/M10	M5 x 25	1 x 20
1 1/4"	39-43	M8/M10	M5 x 25	1 x 20
1 1/2"	45-51	M8/M10	M5 x 25	1.2 x 20
55mm	54-58	M8/M10	M5 x 25	1.2 x 20
2"	60-65	M8/M10	M5 x 25	1.2 x 20
70mm	67-71	M8/M10	M5 x 25	1.2 x 20
2 1/2"	74-82	M8/M10	M6 x 30	1.5 x 25
85mm	82-89	M8/M10	M6 x 30	1.5 x 25
3"	91-98	M8/M10	M6 x 30	1.5 x 25
95mm	93-101	M8/M10	M6 x 30	1.5 x 25
105mm	102-109	M8/M10	M6 x 30	1.5 x 25
4"	109-117	M8/M10	M6 x 30	1.5 x 25
120mm	116-125	M8/M10	M6 x 30	1.5 x 25
125mm	129-141	M8/M10	M6 x 30	2 x 25
5"	136-146	M8/M10	M6 x 30	2 x 25
145mm	142-154	M8/M10	M6 x 30	2 x 25
6"	158-169	M8/M10	M6 x 30	2 x 25
175mm	166-177	M8/M10	M6 x 30	2 x 25

## Zinc Plated Backplate



### Construction

Mild Steel BZP Finish

### Sizes

M8/M10 Dual Boss

# Surefix XL Rubber Lined Clip

For Copper, Plastic and Stainless Steel Pipes

Created on: 31/03/23  
Version: 1.00  
Last Updated: 05/05/23



## Construction

Mild Steel  
BZP Finish

## For Use With

Copper & Plastic Tubes

## Special Features

Rubber Lining tested to  
DIN4109 for Acoustic Use

Pipe Size	Grip Range (mm)	Boss Type	Screw (mm)	Material (mm)
15cu	13-20	M8/M10	M5 x 25	1 x 20
18mm	17-23	M8/M10	M5 x 25	1 x 20
22cu	21-26	M8/M10	M5 x 25	1 x 20
28cu	26-30	M8/M10	M5 x 25	1 x 20
35cu	33-37	M8/M10	M5 x 25	1 x 20
42cu	40-46	M8/M10	M5 x 25	1.2 x 20
1 1/2"	48-53	M8/M10	M5 x 25	1.2 x 20
54cu	53-59	M8/M10	M5 x 25	1.2 x 20
2"	60-66	M8/M10	M5 x 25	1.2 x 20
67cu	67-77	M8/M10	M6 x 30	1.5 x 25
76cu	75-84	M8/M10	M6 x 30	1.5 x 25
3"	83-93	M8/M10	M6 x 30	1.5 x 25
95mm	94-104	M8/M10	M6 x 30	1.5 x 25
108cu	102-111	M8/M10	M6 x 30	1.5 x 25
4"	109-119	M8/M10	M6 x 30	1.5 x 25
120cu	122-135	M8/M10	M6 x 30	2 x 25
133cu	128-139	M8/M10	M6 x 30	2 x 25
5"	135-148	M8/M10	M6 x 30	2 x 25
159cu	151-164	M8/M10	M6 x 30	2 x 25
6"	158-170	M8/M10	M6 x 30	2 x 25

# 316 Stainless Steel Unlined Clip



## Construction

316 Stainless Steel

## For Use With

Trubore & Iso Stainless Steel tubes  
Outdoor and salt water environments

Pipe Size	Grip Range (mm)	Boss Type	Screw (mm)	Material (mm)
3/8"	15-19	M8/M10	M6x20	1.8x20
1/2"	20-25	M8/M10	M6x20	1.8x20
3/4"	26-30	M8/M10	M6x20	1.8x20
1"	32-36	M8/M10	M6x20	1.8x20
1-1/4"	38-43	M8/M10	M6x20	1.8x20
1-1/2"	47-51	M8/M10	M6x20	1.8x20
54mm	53-58	M8/M10	M6x20	1.8x20
2"	60-64	M8/M10	M6x20	1.8x20
70mm	68-72	M8/M10	M6x20	1.8x20
83mm	81-86	M8/M10	M6x20	1.8x20
3"	87-92	M8/M10	M6x20	1.8x20
3-1/2"	99-105	M8/M10	M6x20	1.8x20
4"	113-118	M8/M10	M6x20	1.8x20
125mm	125-130	M8/M10	M6x20	1.8x20
5"	138-142	M8/M10	M6x20	1.8x20
6"	159-166	M8/M10	M6x20	1.8x20

# 316 Stainless Steel Backplate



## Construction

316 Stainless Steel

## Sizes

M8/M10 Duel Boss



## Construction

316 Stainless Steel  
EPDM Rubber Lining

## For Use With

Trubore & Iso Stainless Steel  
tubes  
Outdoor and salt water  
environments

Pipe Size	Grip Range (mm)	Boss Type	Screw (mm)	Material (mm)
3/8"	15-19	M8/M10	M6x20	1.8x20
1/2"	20-25	M8/M10	M6x20	1.8x20
3/4"	26-30	M8/M10	M6x20	1.8x20
1"	32-36	M8/M10	M6x20	1.8x20
1-1/4"	38-43	M8/M10	M6x20	1.8x20
1-1/2"	47-51	M8/M10	M6x20	1.8x20
54mm	53-58	M8/M10	M6x20	1.8x20
2"	60-64	M8/M10	M6x20	1.8x20
70mm	68-72	M8/M10	M6x20	1.8x20
83mm	81-86	M8/M10	M6x20	1.8x20
3"	87-92	M8/M10	M6x20	1.8x20
3-1/2"	99-105	M8/M10	M6x20	1.8x20
4"	113-118	M8/M10	M6x20	1.8x20
125mm	125-130	M8/M10	M6x20	1.8x20
5"	138-142	M8/M10	M6x20	1.8x20

# Heavy Duty Surefix HD Unlined Clip

For Steel Pipes & Insulated Pipe Supports

## Construction

Mild Steel  
 BZP Finish

## For Use With

Steel & Cast Iron Tubes  
 Insulated Pipe Supports



Pipe Size	Grip Range (mm)	Boss Type	Screw (mm)	Material (mm)
50nb / 2"	60-68	M12	M8 x 25	25 x 2
67mm	66-73	M12	M8 x 25	25 x 2
65nb / 2 1/2"	74-81	M12	M8 x 25	25 x 2
85mm	82-88	M12	M8 x 25	25 x 2
80nb / 3"	88-97	M12	M8 x 25	25 x 2
100mm	93-100	M12	M8 x 25	25 x 2
105mm	101-109	M12	M8 x 25	30 x 2.5
100nb / 4"	110-118	M12	M8 x 25	30 x 2.5
120mm	116-126	M12	M10 x 40	30 x .3
135mm	130-141	M12	M10 x 40	30 x .3
125nb / 5"	136-145	M12	M10 x 40	30 x .3
145mm	144-154	M12	M10 x 40	30 x .3
150nb / 6"	160-169	M12	M10 x 40	30 x .3
175mm	170-180	M16	M10 x 40	30 x .3
200nb / 8"	219-230	M16	M10 x 40	30 x .3
250nb / 10"	273-283	M16	M10 x 40	30 x .3

# Heavy Duty Surefix HD Rubber Lined Clip

For Copper, Plastic and Stainless Steel Pipes

## Construction

Mild Steel BZP Finish

## For Use With

Copper & Plastic Tubes

## Special Features

Rubber Lining tested to DIN4109 for Acoustic Use



Pipe Size	Grip Range (mm)	Boss Type	Screw (mm)	Material (mm)
67cu / 2"	60-69	M12	M8 x 25	25 x 2
76cu / 2 1/2"	75-81	M12	M8 x 25	25 x 2
80nb / 3"	83-91	M12	M8 x 25	25 x 2
108cu	102-112	M12	M8 x 25	30 x 2.5
125mm	122-138	M12	M10 x 40	30 x 3
155mm	153-164	M12	M10 x 40	30 x 3
200mm	196-209	M16	M10 x 40	30 x 3

# SUP 100 - Split Band

For Steel Pipes and Insulated Pipe Supports

Created on: 31/03/23  
Version: 1.00  
Last Updated: 05/05/23



## Construction

Mild Steel  
BZP Finish  
HT Sets & Nuts

## For Use With

Steel Tubes  
Cast Iron Tubes  
Insulated Pipe Supports

**Other sizes available on request**

Size ID (mm)	Size NB	Hole Centres (mm)	Bolt Size (mm)	Material Width & Thickness (mm)
65		110	M10 x 40	30 x 3
76	65NB / 2 1/2"	125	M10 x 40	30 x 3
83		131	M10 x 40	30 x 3
89	80NB / 3"	137	M10 x 40	30 x 3
95		145	M12 x 40	30 x 3
102		158	M10 x 40	30 x 3
108		163	M10 x 40	40 x 3
114	100 NB / 4"	177	M10 x 40	40 x 3
121		188	M10 x 40	40 x 3
127		194	M10 x 40	40 x 3
133		202	M10 x 40	40 x 3
140		207	M10 x 40	40 x 3
146		214	M10 x 40	40 x 3
152		222	M10 x 40	40 x 3
159		216	M12 x 40	40 x 3
168	150 NB / 6"	239	M12 x 40	40 x 3
173		243	M12 x 50	40 x 3
178		258	M12 x 50	40 x 3
186		265	M12 x 50	40 x 5
193		266	M12 x 50	40 x 5
199		278	M12 x 50	40 x 5
208		286	M12 x 50	40 x 5
216		299	M12 x 50	40 x 5
220	200 NB / 8"	301	M12 x 50	40 x 5
225		301	M12 x 50	40 x 5
232		309	M12 x 50	40 x 5
244		315	M16 x 50	40 x 5
252		319	M16 x 50	40 x 5
259		326	M16 x 50	40 x 5
268		347	M12 x 50	40 x 5
273	250 NB / 10"	357	M16 x 50	50 x 6
283		366	M16 x 50	50 x 6
290		375	M16 x 50	50 x 6
298		382	M16 x 50	50 x 6
308		402	M16 x 50	50 x 6
323	300 NB / 12"	422	M16 x 50	50 x 6

Tolerance +/-5mm

Supplitech Ltd Reserves the right to alter / amend product data without prior notification



## Properties

CFC/HCFC-free with zero Ozone Depletion Potential (ODP)



High Closed Cell Content

Inert Bore Coated for use on all Pipes Including Copper

General Physical Properties (Metric)						
Property	Test Method	Unit	Typical Value			
Nominal Density (Min)	(EN ISO 845) / (ASTM D 1622)	Kg/m <sup>3</sup>	37	60	80	120
Thermal Conductivity (Min)	(EN 12667) / (ASTM C 518)	W/mK	0.021	0.029	0.03	0.032
Colour			Grey	Grey	Grey	Grey
Operating Temperature Limits	Upper Limit	°C	120	120	120	120
	Lower Limit	°C	-180	-180	-180	-180
Minimum Compressive Strength at +23 °C	(EN 826) / (ASTM D 1621) Parallel	kPa	150	320	590	1000
	Perpendicular	kPa	100	170	440	800

Fire Test Specifications					
Fire Test	Test Method		Specification		
Fire Propagation	BS 476-6: 1989	Index of Performance (I) not exceeding 12 and sub index (i1) not exceeding 6*			
Surface Spread of Flame	BS 476-7: 1997	Class 1*	Class 1*	Class 1*	Class 1*
Vertical Burning	DIN 4102-1: 1998	B2	B2	B2	B2

These test results combined enable a Class 0 classification to the Building Regulations in England & Wales, Northern Ireland and the Republic of Ireland, and a Low Risk classification to the Building Standards in Scotland. These tests were conducted on samples of 25mm/1" thickness faced with a reinforced aluminium foil vapour barrier jacket.

The **Rocktherm™** thermal pipe support inserts are manufactured from high density Stone Wool to suit a full range of diameters and thicknesses covering copper, steel and plastic pipes.

BS5970 2012 thermal insulation code of practice recommends the use of insulated pipe support inserts and that the pipe support bracket be fixed over load bearing insulation of the same material (or compatible with) the insulation on the pipe.

The **Rocktherm™** thermal pipe support inserts are supplied with a factory applied aluminium foil vapour barrier and are cut to the required length. A half metal sleeve (or full if required) can be applied, often required from 48mm O/D and above.

The use of factory manufactured Stone Wool insulated load bearing thermal pipe support inserts will greatly reduce the risk of condensation on cold/chilled water pipe applications, providing continuous insulation and vapour resistance as well as enhancing the thermal insulation performance of the system. The thermal pipe support inserts should also be used on hot and heating pipe work for continuous thermal insulation and reduction in heat loss.

## Manufacturing Process

The **Rocktherm™** thermal pipe support inserts are manufactured from Paroc Pro Slab with a density of 200kg/m<sup>3</sup> as standard, an aluminium foil vapour barrier is then adhered to the outer surface with an aqueous inorganic, non-combustible adhesive.

## Dimensional Stability

Although the material has a maximum service temperature of 660°C and maintains dimensional stability in slab form, the maximum service temperature for dimensional Stability as a pipe insert is **250 °C**

## Product Characteristics

PROPERTY	DESCRIPTION
Standard O/D Range	15mm to 205mm
	Other diameters available on request
Standard Wall Thickness	20mm to 100mm
	Other thicknesses available on request
Standard Lengths	80mm & 100mm
Nominal Density	200kg/m <sup>3</sup>
Reaction to Fire	Non-combustible

# ROCKTHERM™

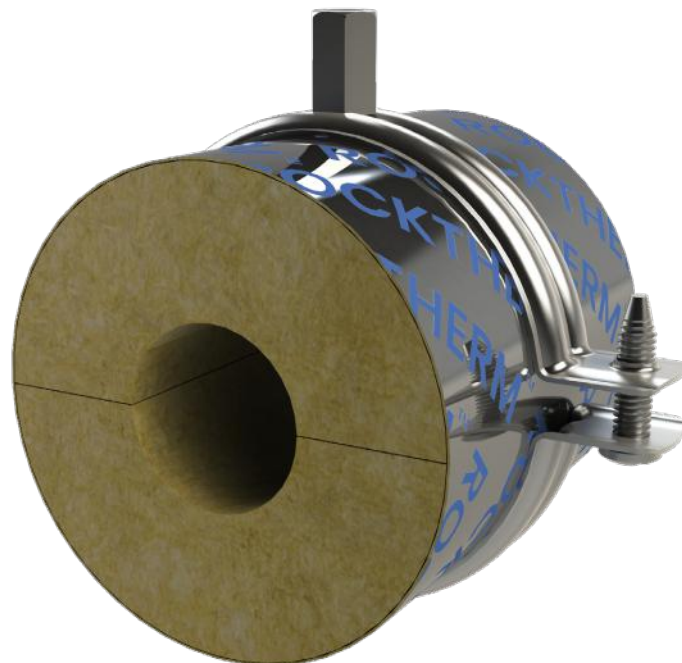

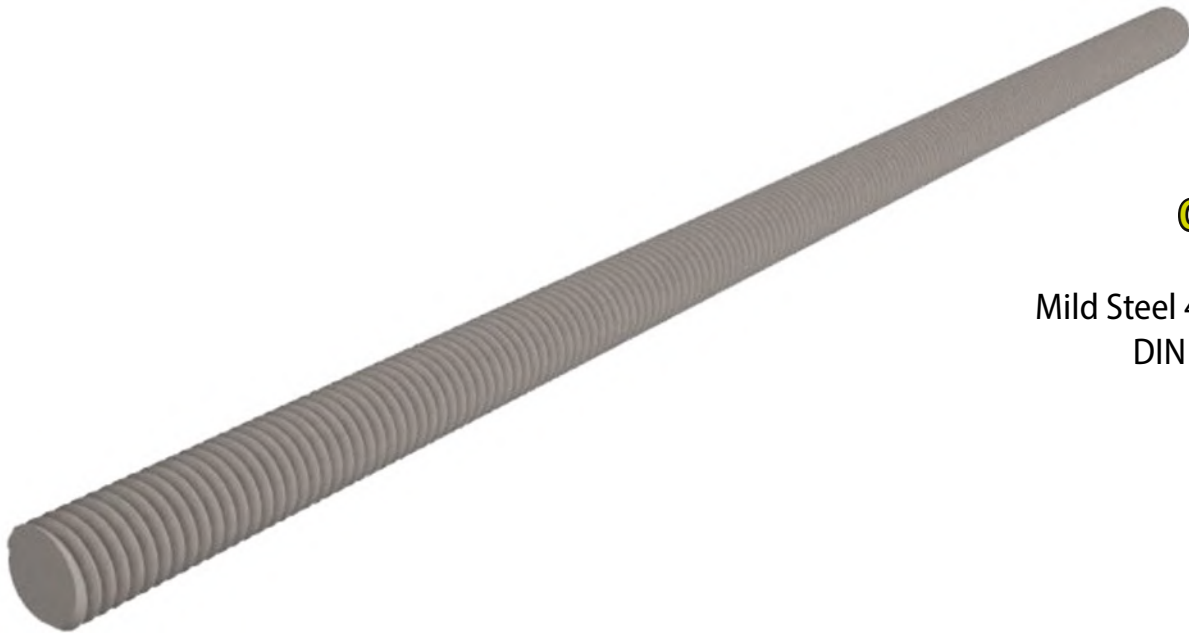

## Construction

Mild Steel 4.8 Grade to  
 DIN EN20891.-1

BZP Finish

Standard Lengths	Cut Lengths (mm)		
Size	Size	Size	Size
M6 x 1m	M10 x 25	M10 x 160	M10 x 350
M6 x 3m	M10 x 30	M10 x 170	M10 x 360
M8 x 3m	M10 x 40	M10 x 180	M10 x 370
M10 x 1m	M10 x 50	M10 x 200	M10 x 390
M10 x 3m	M10 x 60	M10 x 210	M10 x 400
M12 x 1m	M10 x 70	M10 x 220	M10 x 450
M16 x 1m	M10 x 80	M10 x 230	M10 x 465
M16 x 3m	M10 x 90	M10 x 240	M10 x 500
	M10x100	M10 x 250	M10 x 550
	M10 x 110	M10 x 275	M10 x 580
	M10 x 120	M10 x 280	M10 x 600
	M10 x 125	M10 x 300	M10 x 650
	M10 x 130	M10 x 310	M10 x 700
	M10 x 140	M10 x 320	M10 x 750
	M10 x 150	M10 x 340	M10 x 800

Tolerance +/-5mm

# SUP 104 S/E 'U' Bolt

For Steel Pipes & Insulated Pipe Supports

Created on: 31/03/23  
Version: 1.00  
Last Updated: 05/05/23

## Construction

Mild Steel  
BZP Finish

## For Use With

Steel Tubes  
Cast Iron Tubes  
Insulated Pipe Supports



Size ID (mm)	Rod Dia (mm)	Size NB (mm)	Rod Dia (mm)
46	M10		
51	M10		
56	M10		
62	M10		
67	M10		
72	M10		
78	M10		
85	M10		
91	M10	15	M6
97	M10	20	M6
104	M10	25	M6
110	M10	32	M10
116	M10	40	M10
123	M10	50	M10
129	M10	65	M10
135	M12	80	M12
141	M10	100	M12
146	M12	125	M12
150	M10	150	M12
154	M12	200	M16
161	M10	250	M16
166	M12	300	M16
170	M12		
175	M12		
180	M12		
185	M12		
191	M12		
195	M12		
201	M12		
208	M12		
212	M12		
216	M12		
222	M12		
228	M12		
234	M12		
240	M12		
246	M12		
254	M12		
260	M16		
264	M12		
268	M12		
275	M16		
285	M16		
292	M16		
301	M16		
310	M16		

# SUP 170 - Filbow Clamp

LPCB Approved for Steel Pipes



LPS 1194: Issue 1.2  
 Cert/LPCB ref. 1568a

### Construction

Cold Rolled Mild Steel  
 Pre-Galv Finish

### For Use With

Steel Tubes

Nominal Imperial	OD (mm)	Height	Width (mm)	Hole Ø	Material (mm)
1/2"	28	51.5	36.5	10.5	25 x 1.2
3/4"	30	53.5	37.5	10.5	25 x 1.2
1"	36	65.5	46.5	10.5	25 x 1.2
1 1/4"	46	79.9	55.7	10.5	25 x 1.2
1 1/2"	52	85.9	58.7	10.5	25 x 1.2
2"	66	99.9	65.7	10.5	25 x 1.2
2 1/2"	78	116	75.5	10.5	25 x 1.5
3"	92	132	84.5	10.5	25 x 1.5
4"	116	167.5	107.5	10.5	25 x 2
5"	142	200	126.5	13	32 x 2.5
6"	170	238	150.5	13	32 x 3

## SUP 203 - Bow Nut



### Construction

Mild Steel  
 BZP Finish

### Sizes Available

M10, M12, M16, M20

## SUP - Ball Hanger



Size	Movement	SWL
M8	+/-5°	1.5kN
M10	+/-5°	2.0kN
M12	+/-5°	2.5kN

### Construction

Mild Steel BZP Finish

### For Use With

Unlined & Lined Clip Range &  
 Hanging brackets to reduce  
 drop rod lateral loads

## Wedge Nut

### Construction

Mild Steel  
 BZP Finish

### Sizes Available

M6, M8, M10 & M12

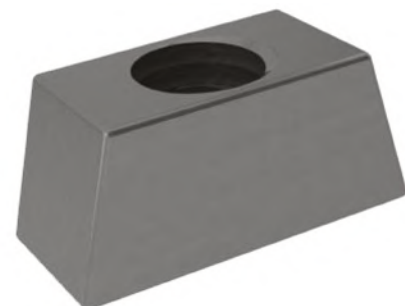

## Construction

### SUP 240 G/M/B/C - Munsen Rings

Metric Threads



240G = Galvanised

240M = Malleable Iron

240B = Cast Brass

240C = Chrome

### SUP 241 G/M/B/C - School Board Clips



241G = Galvanised

241M = Malleable Iron

241B = Cast Brass

241C = Chrome

### SUP 242 G/M/B/C - Backplates



242G = Galvanised

242M = Malleable Iron

242B M10 Male & Female Threads



242C M10 Male & Female Threads

## STRUT: Plain or Slotted

- 41 x 41 x 6m
- 41 x 41 x 3m
- 41 x 21 x 6m
- 41 x 21 x 3m
- 41 x 41 x 6m Back to Back
- 41 x 41 x 3m Back to Back
- 41 x 21 x 6m Back to Back
- 41 x 21 x 3m Back to Back

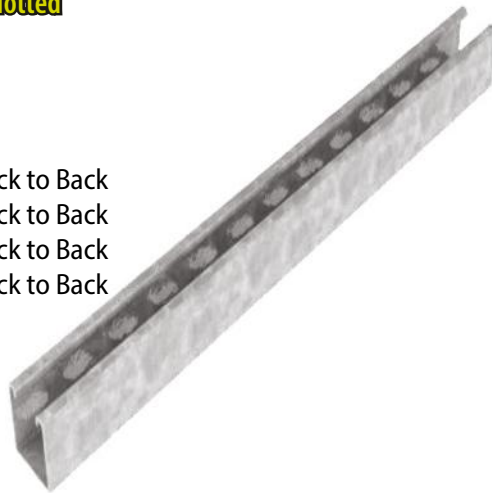

## CANTILEVER ARMS

- 150mm Long
- 300mm Long
- 450mm Long
- 600mm Long
- 750mm Long

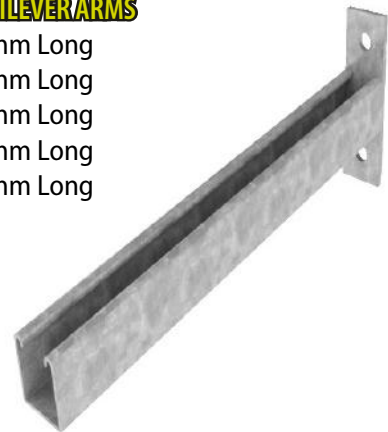

STUDDING 1m & 3m



NUTS

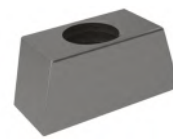

WEDGE NUTS



WASHERS



BOLTS & SETS



PURLIN CLIPS



CHANNEL NUTS

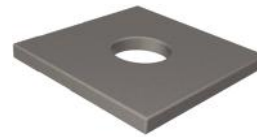

SUP01



SUP02

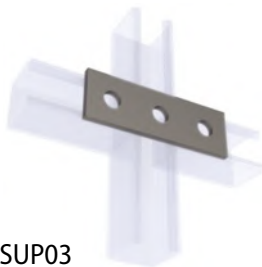

SUP03

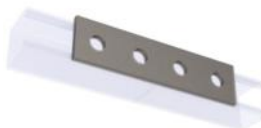

SUP04



SUP05



SUP06



SUP07



SUP08

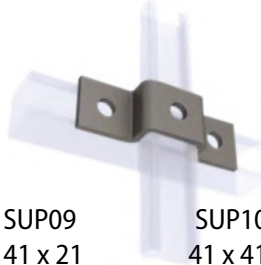

SUP09  
41 x 21



SUP10  
41 x 41

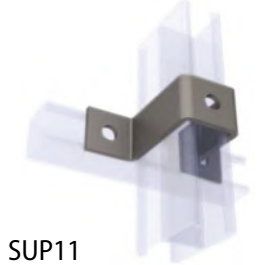

SUP11



SUP12



SUP13



SUP14



SUP15



SUP16



SUP17



SUP18



SUP19



SUP20



SUP21



SUP23



SUP25

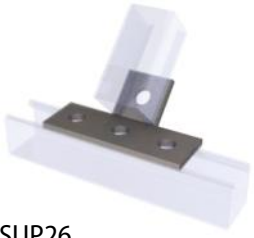

SUP26



SUP27



SUP28



SUP29



SUP30

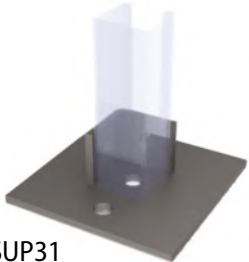

SUP31

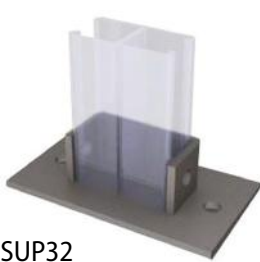

SUP32



SUP33



SUP35



SUP37



SUP38



SUP39



SUP40



SUP41



SUP42



SUP42

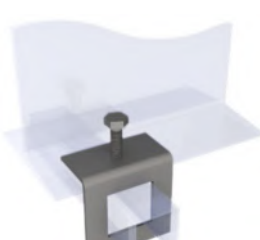

SUP44

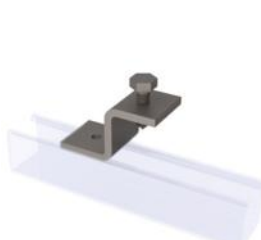

SUP45

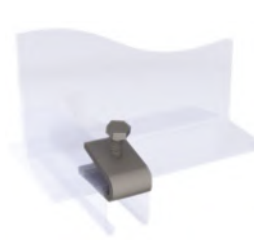

SUP46



SUP47



SUP48



SUP49

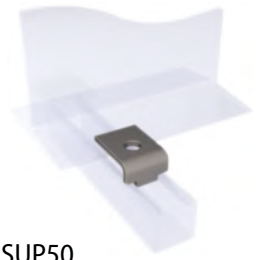

SUP50



SUP51

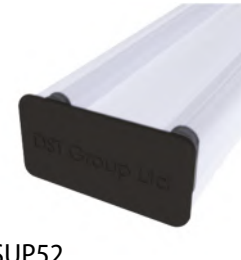

SUP52



## Key Points

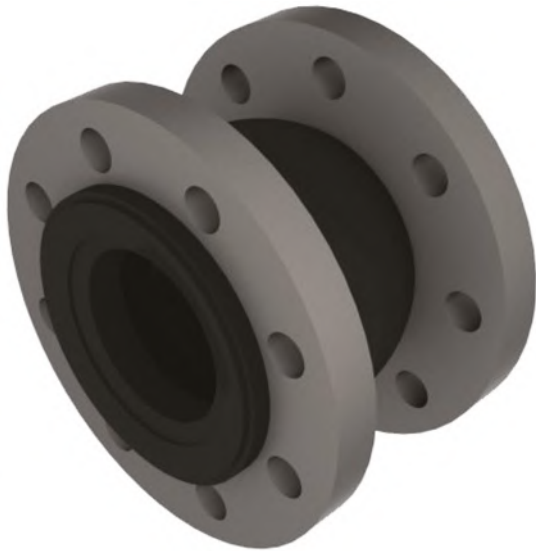

Flanges: Carbon Steel - Drilled PN16 or PN6  
(Other Flanges Available )

Nylon Re-inforced EPDM Rubber Body

Steel Reinforced Collars

Round flanges - No Tie Bars

Size (mm)	Installed Length	Material Type	Temperature Limits °C	Part Number
32	130	Nylon Reinforced EPDM	-10 - 90	SUP/032/PN16/6
40	130	Nylon Reinforced EPDM	-10 - 90	SUP/040/PN16/6
50	130	Nylon Reinforced EPDM	-10 - 90	SUP/050/PN16/6
65	130	Nylon Reinforced EPDM	-10 - 90	SUP/065/PN16/6
80	130	Nylon Reinforced EPDM	-10 - 90	SUP/080/PN16/6
100	130	Nylon Reinforced EPDM	-10 - 90	SUP/100/PN16/6
125	130	Nylon Reinforced EPDM	-10 - 90	SUP/125/PN16/6
150	130	Nylon Reinforced EPDM	-10 - 90	SUP/150/PN16/6

SUP S-Flex Pump Flexibles are installed to absorb vibration and noise levels caused by "Plant" upon which they are fitted. These are suitable for use on systems carrying Chilled & Heating Water. Please see above for temperature & Pressure limits.

SUP S-Flex units are not suitable for use with Potable Water, Water with Oil additives, Compressed Air and Food Applications.

SUP S-Flex Untied units should not be installed on pumps located on Inertia bases

SUP S-Flex units are manufactured from spherical moulded EPDM, which is a soft compound to offer a high isolation efficiency and high noise absorbing properties.

The units are a full bore thus removing pressure drop problems. The EPDM rubber is nylon re-inforced, and has a steel wire re-inforced collar.

Flanges BZP coated carbon steel PN16.

S-Flex units have up to 10 year design life\* and are warranted for a period of 12 months\*\* from supply.

SUP S-Flex units are stamped with Origin of Manufacture, Date Of Manufacture, Batch Number and Size.

Please note no torsion forces should be applied to these units.

Supplitech also Supply DIN 4809 Approved Pump Flexibles. Please Contact our Sales Office for further information.

\* Design life is guidance only. This guidance assumes the unit will not be working at the extremes of its working capacity. This in no way implies a warranty or a guarantee.

\*\* 12 Months warranty is against manufacturing defect only and is limited to the supply only of a replacement product of the same type.

## Key Points

Flanges: Carbon Steel - Drilled PN16  
(Other Flanges Available )

Nylon Re-inforced EPDM Rubber Body

Steel Reinforced Collars

Tie Bars: Anti-Tamper Carbon Steel

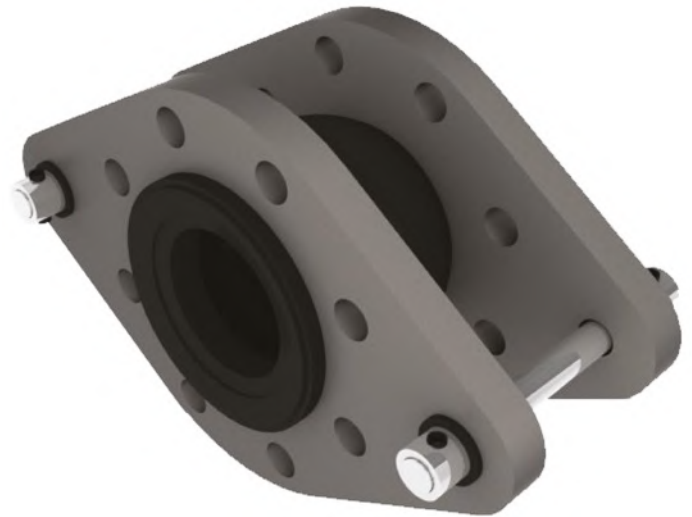

Size (mm)	Installed Length	Material Type	Temperature Limits °C	Part Number
32	130	Nylon Reinforced EPDM	-10 - 90	SUP/032/PN16T
40	130	Nylon Reinforced EPDM	-10 - 90	SUP/040/PN16T
50	130	Nylon Reinforced EPDM	-10 - 90	SUP/050/PN16T
65	130	Nylon Reinforced EPDM	-10 - 90	SUP/065/PN16T
80	130	Nylon Reinforced EPDM	-10 - 90	SUP/080/PN16T
100	130	Nylon Reinforced EPDM	-10 - 90	SUP/100/PN16T
125	130	Nylon Reinforced EPDM	-10 - 90	SUP/125/PN16T
150	130	Nylon Reinforced EPDM	-10 - 90	SUP/150/PN16T
200	130	Nylon Reinforced EPDM	-10 - 90	SUP/200/PN16T
250	130	Nylon Reinforced EPDM	-10 - 90	SUP/250/PN16T
300	On Request	Nylon Reinforced EPDM	-10 - 90	SUP/300/PN16T
350	On Request	Nylon Reinforced EPDM	-10 - 90	SUP/350/PN16T
400	On Request	Nylon Reinforced EPDM	-10 - 90	SUP/400/PN16T

SUP S-Flex Pump Flexibles are installed to reduce Vibration and noise levels caused by "Plant" upon which they are fitted. These are suitable for use on systems carrying Chilled & Heating Water. Please see above for temperature & Pressure limit. SUP S-Flex units are not suitable for use with Potable Water, Water with Oil additives, Compressed Air and Food Applications.

SUP S-Flex units are manufactured from spherical moulded EPDM, which is a soft compound to offer a high isolation efficiency and high noise absorbing properties.

The S-Flex units tied type has specially designed anti tamper tie bars. This will only allow the units to be installed at their optimal length and avoid elongation of the unit. These units rated to Maximum 10bar working pressure, 15bar test pressure

The units are a full bore thus removing pressure drop problems. The EPDM rubber is nylon re-inforced, and has a steel wire re-inforced collar.

Flanges BZP coated carbon steel PN16.

S-Flex units have up to 10 year design life\* and are warrantied for a period of 12\*\* months from supply.

SUP S-Flex units are stamped with Origin of Manufacture, Date Of Manufacture, Batch Number and Size.

Please note no torsion forces should be applied to these units.

Supplitech also supply DIN 4809 Approved Pump Flexibles. Please contact our sales office for further information.

\* Design life is guidance only. This guidance assumes the unit will not be working at the extremes of its working capacity. This in no way implies a warranty or a guarantee.

\*\* 12 Months warranty is against manufacturing defect only and is limited to the supply only of a replacement product of the same type.

## Key Points



Unions: Carbon Steel

Nylon Re-inforced EPDM Rubber Body

Steel Reinforced Collars

Size (mm)	Installed Length	Material Type	Temperature Limits °C	Part Number
15	200	Nylon Reinforced EPDM	-10 - 90	PGS/015
20	200	Nylon Reinforced EPDM	-10 - 90	PGS/020
25	200	Nylon Reinforced EPDM	-10 - 90	PGS/025
32	200	Nylon Reinforced EPDM	-10 - 90	PGS/032
40	200	Nylon Reinforced EPDM	-10 - 90	PGS/040
50	200	Nylon Reinforced EPDM	-10 - 90	PGS/050

SUP S-Flex Pump Flexibles are installed to absorb vibration and noise levels caused by "Plant" upon which they are fitted. These are suitable for use on systems carrying Chilled & Heating Water. Please see above for temperature & Pressure limits.

SUP S-Flex units are not suitable for use with Potable Water, Water with Oil additives, Compressed Air and Food Applications.

SUP S-Flex Untied units should not be installed on pumps located on Inertia bases

SUP S-Flex units are manufactured from spherical moulded EPDM, which is a soft compound to offer a high isolation efficiency and high noise absorbing properties.

The units are a full bore thus removing pressure drop problems. The EPDM rubber is nylon re-inforced, and has a steel wire re-inforced collar.

Unions BZP coated carbon steel PN16.

S-Flex units have up to 10 year design life and are warranted for a period of 12 months from supply.

SUP S-Flex units are stamped with Origin of Manufacture, Date Of Manufacture, Batch Number and Size.

Please note no torsion forces should be applied to these units.

Suplitech also supply DIN 4809 approved pump flexibles. Please contact our sales office for further information.

Upto 10 Years Design Life\* on LTHW & CHW systems. - 12 Months Warranty\*\* from date of supply. - Not suitable for potable water.

### Flange Suitability:

Weld Neck Flanges



Slip on Flange



Slip-on Flange with Gasket



### Pre-Installation Check

#### 1. Selection

Prior to installation, check you have the right flexibles for the particular duty. All SUP S-Flex Rubber Pump Flexibles have temperature and pressure limitations. Please see the appropriate data sheets for your particular product. This is NOT a product for taking up pipework expansion.

All rubber flexibles will extend under pressure. This creates thrust forces which can be very substantial. We recommend at pressures above 2 Bar and diameters above 65mm nominal bore size, unless the pipe work can be sufficiently anchored directly after the unit, the SUP S-Flex Anti-Tamper Tied pump flexibles should be used.

#### 2. Mating Flanges

We recommend the rubber flexibles are mated up against full-bore weld neck flanges. If installed in this manner no additional gaskets are required.

We advise against using slip-on or screwed flanges as mating flanges, as these can damage the rubber bellows. Once the sealing face has been damaged, water/medium will penetrate the reinforcement layers and destroy the integrity of the flexibles.

If it is unavoidable to use this type of mating flange, a gasket must be installed (this should be a hard gasket and be at least 3mm thick). The gasket should reach the internal bore of the rubber bellows. Another option is to fill the gap of the slip-on flange with weld and grind it flush. However, the surface finish must be level and smooth to ensure that the bellow is not damaged once installed.

#### 3. Misalignment

Check the two mating flanges are parallel and that they are in line (maximum allowed offset is 5mm in any direction). The gap between flanges should be within +/- 5mm of the flexibles neutral. Compression or extension should be avoided.

Under no circumstances must the pump flexible be used to take up misalignment. Ensure the pipework is adequately supported. The flexible must not support pipes or plant.

### Installation - (To Be Performed by Qualified Personnel)

#### 1. Bolts

Bolts should be inserted from the bellows side (as shown on the diagram below). On some larger bolt lengths this may not be possible. In these cases a bolt of the exact and correct length needs to be selected.

An alternative is to use studding cut to length and fitted with a nut at both sides. Please select the bolt length carefully; even if there is space between the bolt and the rubber body of the bellow in an un-pressurised state, they may foul when pressurized and cause failure. Bolts of the right diameter must be used to ensure correct alignment.

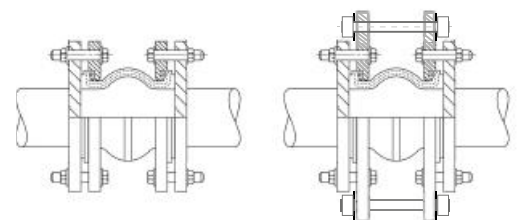

#### 2. Alignment

Take care when inserting the flexibles into the gap between the two mating flanges. Sharp edges can damage the sealing face of the rubber flexibles. Before tightening the bolts, ensure the flexible sits evenly in its flange groove and does not get pinched between flanges. The sealing face of the flexibles must be concentric with the sealing face of the mating flanges.

#### 3. Tightening the Bolts

Great care must be taken with the tightening of the flange bolts. Remember you are tightening against a rubber face. As with gaskets, over tightening will cause the joints to leak and it will damage the bellows. Tighten opposite bolts to get an even pressure all round (check the gap between the flanges). Rubber will set and the bolts will have to be retightened after 24 hours.

#### 4. Tie Bars

Do not fit aftermarket tie bars to a SUP S-Flex Pump Flexible. S-Flex Tied Pump Flexibles are supplied with tie bars, if you need to fit tie bars to an untied unit it should be changed for a S-Flex Tied Unit. When three or more tie bars are fitted it may be necessary to remove one tie bar to install the bellows. Ensure that washers are re-assembled in the right order and orientation.

\* Design life is guidance only. This guidance assumes the unit will not be working at the extremes of its working capacity. This in no way implies a warranty or a guarantee.

\*\* 12 Months warranty is against manufacturing defect only and is limited to the supply only of a replacement product of the same type.

### Taking Care of Rubber Flexibles:

1. Paint - Do not paint rubber flexibles. The paint will attack the rubber (this also applies to paint splatter).
2. Welding - Protect the rubber from weld spatter.
3. Lagging - Do not lag rubber flexibles on heating systems. The increased temperature will reduce life.
4. Tie Bar Check - Once the system is filled but not under pressure, check the tie bars are still tight (pipe work on springs may have dropped due to the weight of the water).

Note: Tied Pump Flexibles are supplied with anti-tamper tie bars, therefore the Tie bars cannot be slackened off and should not be removed, doing so could lead to, major damage to the unit thus damaging equipment.

5. Water Treatment – The pump flexible range incorporates an EPDM inner liner. EPDM is a proven material in heating and chilled water systems. It is resistant to glycol and to most chemicals used in water treatment, when used in normal concentrations. We cannot approve any specific chemical, and suggest you always check with the chemical supplier that the additives are suitable for use with EPDM rubber.

### Best Practice

The following are only recommendations but if followed they will ensure proper installation and maximum service life of the rubber bellows. We recommend the use of spool pieces to align mating flanges and to ensure the correct gap.

1. Pump flexibles should NEVER be used to counter mis-alignment in pipework.
2. Pump flexibles should never be used to support the pipework. Correct guiding and anchoring should be installed close to the pump flexibles.

3. PUMPS - When the pump flexibles are installed on rotating equipment such as pumps to absorb noise and vibration, the first bracket position after the flexibles should be an anchor. This allows the flexibles to absorb vibration but limits their ability to extend under pressure acting as an acoustic break. If pumps are not mounted on springs or inertia bases untied pump flexibles can be used.

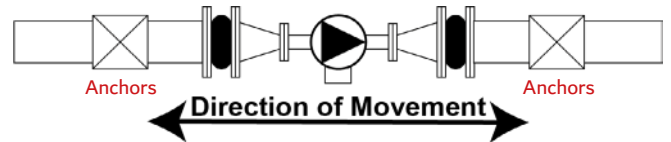

4. INERTIA BASES - Where pumps are installed on inertia bases, Tied Pump Flexibles Should be used. The flexible connection should be directly onto the pump or as near as possible, with anchor points installed after the flexible.

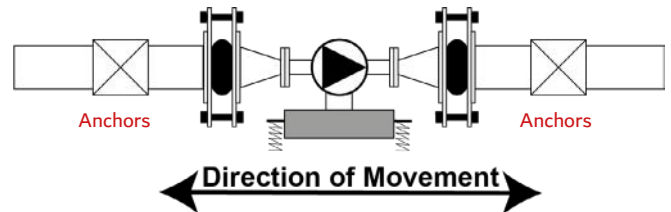

5. IN A RISE - Where pumps are installed on inertia bases, care should be taken NOT to install pump flexibles in vertical pipework on either the return to the pump or flow from the pump. the reasons for this are
  - i. The movement direction changes from axial to lateral.
  - ii. As a result, dependant upon where in the rise the flexibles are, a greater amount of movement can be expressed on the unit laterally, and can be a compound movement with angulation too.
  - iii. Pipe has a greater tendency to use the flexible as a support, as any rigid support would stop the inertia base from working.

In these circumstances neither tied or untied versions are suggested, although, if there is no alternative, a tied unit will offer a better degree of protection.

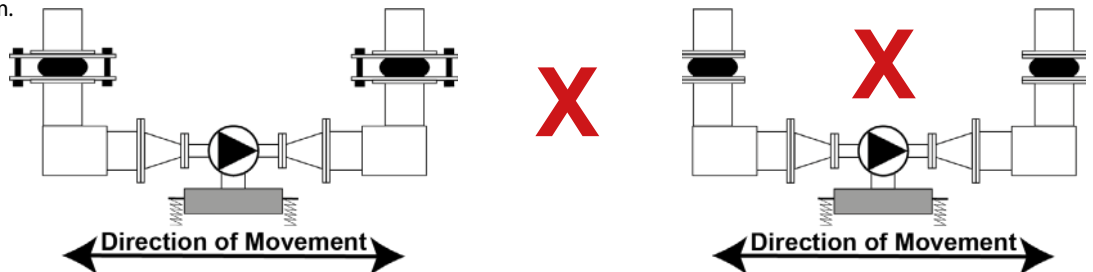

5. PIPE RUNS - Where pump flexibles are being installed to compensate for pipe borne vibration, the flexible still requires anchor on each side to restrict the possibility of extension under pressure. All pipework should be correctly supported between anchors with slide guides to allow movement.

### Key Points

Suitable for Potable Water

Suitable for High Temperatures

PED Certified as Required

Stainless Steel to all Wetted Areas

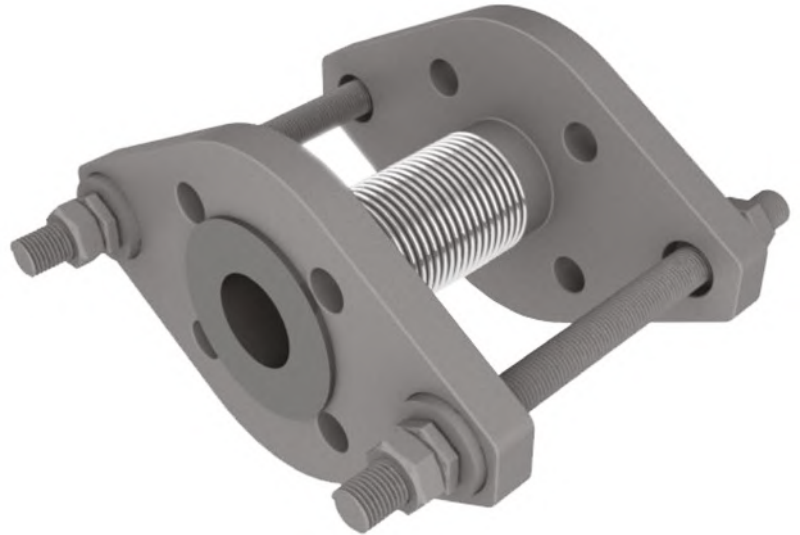

Size (mm)	Installed Length	Material Type	Temperature Limits °C	Part Number
32nb / 35cu	150	316 St/Steel to all Wet Areas	-10 - 200	FA3/032/PN16T
40nb / 42cu	150	316 St/Steel to all Wet Areas	-10 - 200	FA3/040/PN16T
50nb / 54cu	150	316 St/Steel to all Wet Areas	-10 - 200	FA3/050/PN16T
65nb / 67cu	150	316 St/Steel to all Wet Areas	-10 - 200	FA3/065/PN16T
80nb / 76cu	150	316 St/Steel to all Wet Areas	-10 - 200	FA3/080/PN16T
100nb / 108cu	150	316 St/Steel to all Wet Areas	-10 - 200	FA3/100/PN16T
125nb / 133cu	150	316 St/Steel to all Wet Areas	-10 - 200	FA3/125/PN16T
150nb / 159cu	150	316 St/Steel to all Wet Areas	-10 - 200	FA3/150/PN16T
200nb	150	316 St/Steel to all Wet Areas	-10 - 200	FA3/200/PN16T
250nb	On Request	316 St/Steel to all Wet Areas	-10 - 200	FA3/250/PN16T
300nb	On Request	316 St/Steel to all Wet Areas	-10 - 200	FA3/300/PN16T
350nb	On Request	316 St/Steel to all Wet Areas	-10 - 200	FA3/350/PN16T
400nb	On Request	316 St/Steel to all Wet Areas	-10 - 200	FA3/400/PN16T

SUP S-Flex Pump Flexibles are installed to reduce Vibration and noise levels caused by "Plant" upon which they are fitted. These are suitable for use on systems carrying high temperature water or potable water systems. Please see above for temperature & Pressure limits. SUP FA3 units are suitable for use with Potable Water, Water with Oil additives, Compressed Air and Food Applications.

### Material Specification

Connections:	Carbon Steel Drilled PN16 Van-stone Facings
Convolutions:	316 Stainless steel
Internal Sleeve:	316 Stainless steel
Tie Rods:	Carbon Steel
Hemispherical Washers:	Carbon Steel
Connecting Spool:	316 Stainless steel

The SUP Type FA3 Pump Flexible is suitable for use on systems up to 200oC at 16 bar pressure. PED certification supplied dependant upon application.

All units are supplied at installation lengths and are pre stressed. Please note, Supplitech can design and supply flexible connections to accommodate higher system temperatures / pressures. Please advise at time of enquiry / order the system temperature and pressure to allow correct selection of compensator.

# RapidVent Air & Dirt Separator

## Key Points



Microbubble Type

Flanged PN16

10 Bar Working Pressure

110 Degrees C

For use in sealed heating and cooling systems. Air and Dirt Separators protect against damage caused by the deposit of dirt particles, and large amounts of dissolved and undissolved air.

### Reduction in:

- Corrosion of pipe and fittings.
- Dependence on chemicals.
- Unwanted dirt build up in equipment & pipe

### Whilst increasing efficiency of:

- Boilers & Heat Exchangers.
- Chillers
- Pumps

Air and dirt separators are essential when refurbishing older systems or when an open system is converted to a closed system.

- Flanged connection EN 1092-1 PN16.
- Flow Rate up to 1.5 m/s.

Pipe Size	Face to Face L	Body Diameter D	Height H	Flange	Flow Rate @ 1.5m/s
50mm	430mm	168mm	589mm	PN16	12m <sup>3</sup> /h
65mm	430mm	168mm	589mm	PN16	20m <sup>3</sup> /h
80mm	490mm	220mm	780mm	PN16	28m <sup>3</sup> /h
100mm	490mm	220mm	780mm	PN16	47m <sup>3</sup> /h
125mm	630mm	325mm	952mm	PN16	70m <sup>3</sup> /h
150mm	630mm	325mm	952mm	PN16	100m <sup>3</sup> /h
200mm	810mm	410mm	1266mm	PN16	175m <sup>3</sup> /h

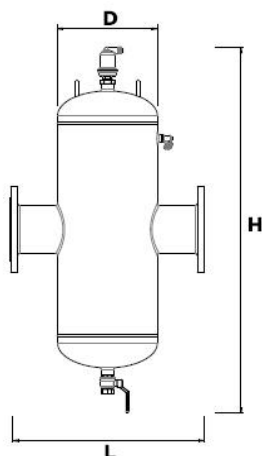

## Pressure Drop Chart

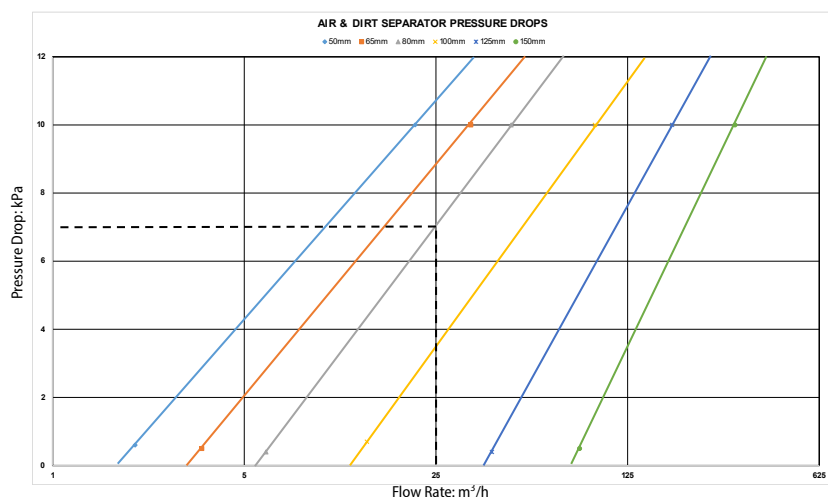

Supplitech Ltd Reserves the right to alter / amend product data without prior notification

## RapidVent Air & Dirt Separators

### Selection & Location

1. Micro Bubbles are easily released from circulating water where the highest temperature and lowest pressure conditions occur in the system
2. The separators should normally be fitted where water is at the highest temperature and the lowest pressure available.
3. When selecting the position for the separator please be aware that pressure also has a major effect on the release of microbubbles.
5. Where lower temperatures are involved in cooling applications system pressure becomes the determining factor of the position of the separator.
7. Rapidvent air and dirt separators should be installed in horizontal pipework, the direction of flow is optional.
8. The static head must not exceed 15m for a heating system and 5m for a cooling / Chilled Water system.
9. The efficiency of the unit will be reduced if the system static head exceeds those indicated or system or flow velocity exceeds 1.5m/s.

### Installation (To Be Performed by Qualified Personnel)

1. Protect the Rapidvent air & dirt separator from adverse environmental conditions, protect from frost.
2. This equipment will form part of the main system's maintenance regime, do not obstruct access.
3. The main system must be flushed before installation of the air & dirt separator.
4. Jet Air & Dirt separators are not directional.
5. The equipment must be installed vertically with isolation valves on the inlet and outlet connections to facilitate maintenance inspection and facilitate the venting of separated dirt.
6. To provide the best protection for your system typically this equipment is installed on the hottest side of the heat exchanger, on the suction side of the circulation pump. Please refer to section "Location" for more details.
7. For service purposes it is essential to have 100 mm access clearance above the air vent when installed.
8. When installing, please take into account the weight of the unit, and use the correct equipment for lifting and fitting. Lifting eyes are provided on 150mm and above.
9. Loose accessories should be fitted to unit using Loctite 577 or suitable threadlocking methods:
10. Ensure that the vent cap on the Air Vent is open when commissioning this equipment.
11. Flexible or fixed pipework should be installed to enable dirty water to be drained to a convenient safe place.

### Maintenance (To Be Performed by Qualified Personnel)

1. It is recommended that the Rapidvent air & dirt separator should be inspected and drained of dirt after 3 months, then annually thereafter.
2. Should particulate debris build up within the air vent valve, and induce a leak, this can be isolated using the vent cap until such time as appropriate maintenance can take place.
3. Before draining the particulate debris first isolate the Rapidvent air & dirt separator from the main system.
4. Where temperatures are likely to cause harm, please allow the unit to cool before discharging the debris.
5. Open the drain valve to release the accumulated debris from the equipment.
7. Once complete, close the drain valve and reintroduce the Air & Dirt Separator to the main system by opening the isolation valves.
8. Never use the drain valve or air vent to reintroduce water to the system.

**WARNING: Any and all maintenance must only take place with the equipment isolated from the main system and when the temperature of the unit and fluid is within safe limits.**



## Key Points



304 Stainless Steel Construction

Supplied With Tundish & All Valves

Polished Stainless Steel Finish

Wall Mounting Brackets Fitted

Dosing pots are generally installed in closed systems to enable water treatments and other chemicals to be added to the system without the need to shut a system down or part thereof.

The Chempot is a high quality stainless steel vessel which is fatigue resistant as a result of its design. The unit is supplied with all components loose so connections can be fitted in an orientation best suited to the system.

Chempot is fully compliant with the latest BSRIA BG50/2021 recommendations regarding avoiding dead legs and is compliant with Equipment Directive 2014/68/EU Cat SEP and Pressure Equipment (Safety) Regulations 2016.

### Sizing:

The size of dosing pot installed in a system is not critical as multiple doses of chemicals can be put in to the system to reach the correct concentration.

The benefits of using a smaller unit, is that it is easier to physically handle and also allows for more accurate dosing. However, the time on site for performing multiple doses has to be considered. This factor should influence your decision when selecting dosing pots.

### BSRIA Compliant if installed in this configuration

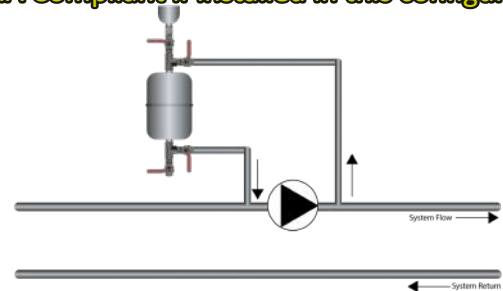

### Not BSRIA Compliant if installed in this configuration - But Acceptable

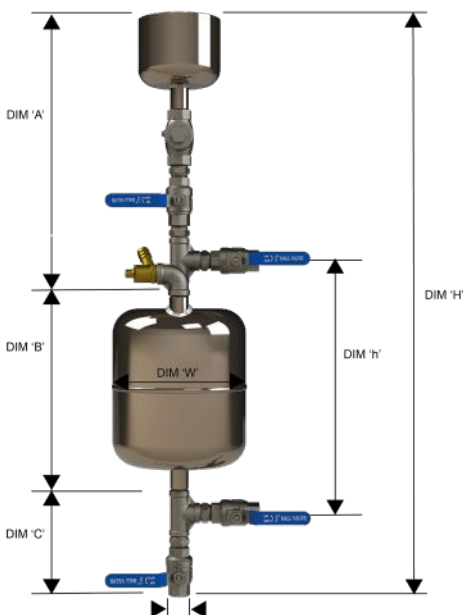
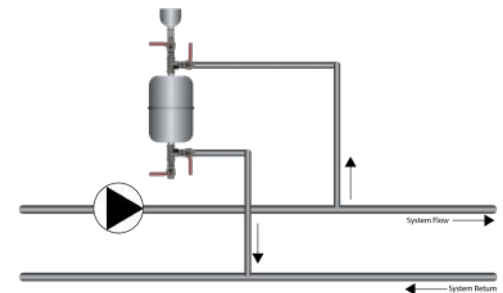

SIZE	Con Size	DIM A	DIM B	DIM C	DIM W	DIM H	DIM h	Working Pressure
3.5L	1/2"	285mm	260mm	130mm	162mm	675mm	310mm	10Bar
6L	1/2"	285mm	260mm	130mm	215mm	675mm	310mm	10Bar
11L	1/2"	285mm	410mm	130mm	215mm	825mm	460mm	10Bar
18L	1/2"	285mm	460mm	130mm	260mm	875mm	510mm	7Bar
25L	1/2"	285mm	590mm	130mm	260mm	1005mm	640mm	7Bar

Inertia bases are designed to support reciprocating equipment such as pumps, chillers, and generators.

Supplitech Inertia Bases are supplied in a flat pack form to allow ease of installation on site but can be delivered assembled if required.

These are supplied with spring mounts and all fixings required to assemble the inertia base.

Supplitech can calculate the size of inertia base required. Please forward the pump details to the Supplitech Sales Office. As standard the Supplitech Inertia Bases are supplied either 150mm or 300mm deep.

Springs when fitted should be loaded equally, installing one spring before another will lead to uneven load.





