

Pergola 4x4M Aluminium

Assembly Instructions - EN

Zusätzlich benötigte Werkzeuge und Sicherheitskleidung für die Installation (nicht enthalten)

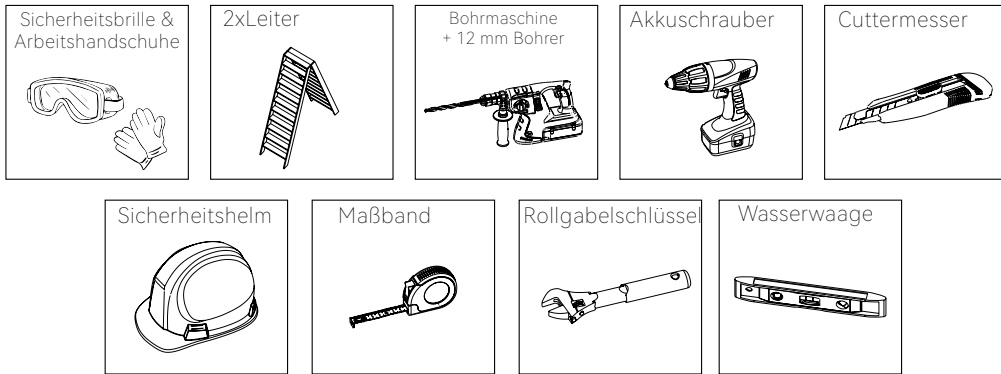

2D Fundamentmessung (Dimension in mm)

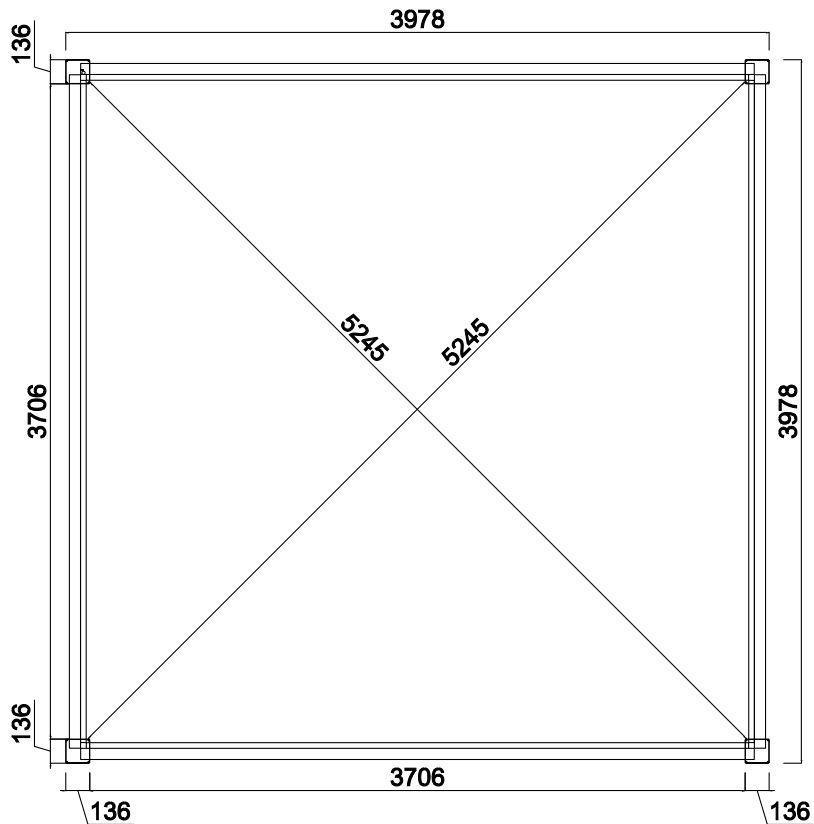

3D Fundamentmessung (Dimension in mm)

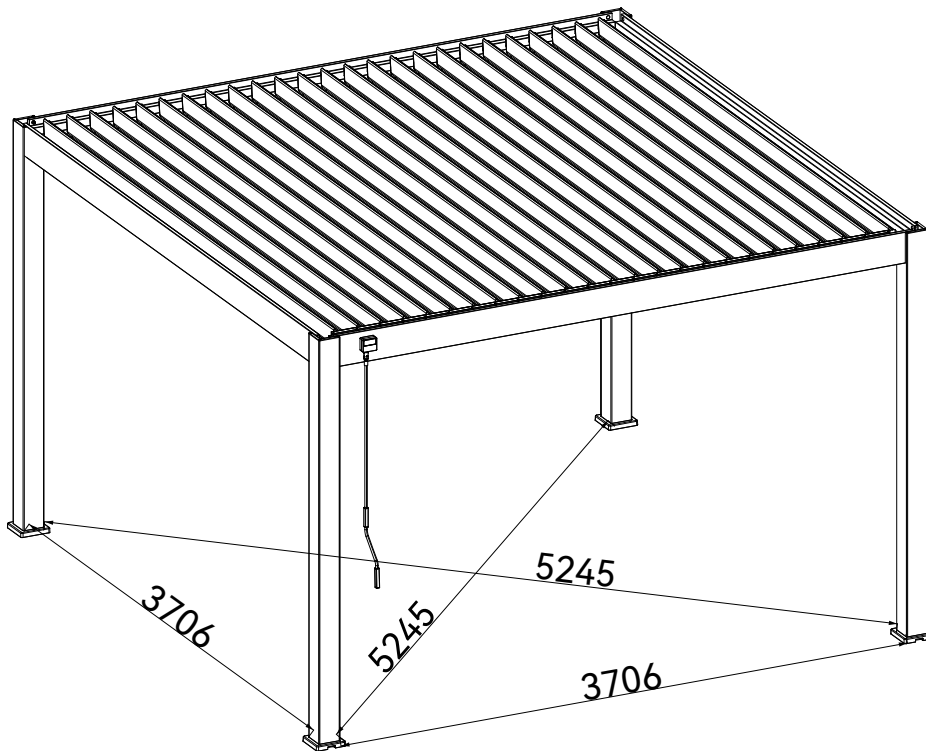

WARNHINWEISE FÜR DEN GEBRAUCH

Dieses Produkt sollte nicht bei extremen Wetterbedingungen wie Stürmen, starkem Wind, Hagel oder Schnee verwendet werden. Wir garantieren die Beständigkeit der Pergola für Windgeschwindigkeiten bis zu 100 km/h und eine maximale Schneelast von 70 kg/m².

Bei starkem Schneefall oder Wind öffnen Sie bitte die Lamellen, um mögliche Schäden zu vermeiden. Entfernen Sie den Schnee regelmäßig vom Dach, um eine Überlastung des Daches zu verhindern.

Unsere Pergola kann starke Regenfälle standhalten, es kann jedoch keine vollständige Wasserdichtigkeit garantiert werden. Bei außergewöhnlichen Wetterereignissen kann die Wasserdichtigkeit beeinträchtigt werden. Lassen Sie keine feuchtigkeitsempfindlichen Produkte unter der Pergola stehen.

Wir raten davon ab, auf das Dach oder das Gestell der Pergola zu klettern. Es besteht die Gefahr von Schäden und Verletzungen.

Tipps und Sicherheitshinweise

Je nach Standort und Fläche kann es sein, dass für den Bau eine Baugenehmigung oder ein Antrag auf Baugenehmigung erforderlich ist. Wir empfehlen Ihnen, sich vor dem Aufbau an Ihre Stadtverwaltung zu wenden, um die entsprechenden Informationen zu erhalten

Produktmontage:

- Es werden 2-3 Personen benötigt
- Entfernen Sie vor der Installation die Schutzfolie von allen Teilen
- Lassen Sie Kinder nicht in der Nähe des Montagebereichs spielen
- Achten Sie auf die Klemmgefahr
- Ziehen Sie die Schrauben nicht vollständig an, bevor Sie die entsprechenden Teile zusammen gebaut haben
- Alle Aufbauschritte müssen genau befolgt werden
- Diagonalen und Auslotungen kontrollieren
- Befestigen Sie die Pergola erst nach dem Zusammenbau

Es dürfen keine Veränderungen am Produkt vorgenommen werden. Vom Benutzer abgeänderte Produkte, fallen nicht mehr unter die Garantie des Herstellers.

Der Standort sollte mit Bedacht gewählt sein. Es wird empfohlen die Pergola nicht bei Regen, in der Hauptwindrichtung oder unter einem Baum aufzustellen.

Die Pergola muss auf einem ausreichend stabilen und ebenen Fundament errichtet werden. Es wird empfohlen, sie auf einer Betonplatte oder auf 25 x 25 cm großen Betonklötzen an jedem Pfosten zu errichten.

Wenn Sie ihre Pergola in der Nähe des Hauses oder eines Gebäudes aufstellen möchten, achten Sie darauf, dass Regenrinnen vorhanden sind, damit Regenwasser abfließen kann. Die Pergola ist nicht dafür ausgelegt, Wasser aufzunehmen, das von Ihrem Haus in sie hineinläuft.

Falls diese Hinweise nicht oder nur teilweise befolgt werden, erlischt die Garantie des Verkäufers.

Wartung

Eine regelmäßige Pflege des Produkts ist nötig, um eine Langlebigkeit des Produkts zu gewährleisten.

Empfehlungen:

- Reinigen Sie die Pergola 1-2-mal im Jahr mit klarem Wasser und einem Schwamm oder Tuch
- Verwenden Sie keine aggressiven Reinigungs oder Scheuermittel.
- Überprüfen Sie regelmäßig (min 1x im Jahr) ob die Schrauben fest angezogen sind.
- Ölen Sie die Befestigungen regelmäßig (mindesten 1x pro Jahr)
- Achten Sie darauf, dass nichts den Wasserabfluss in den Regenrinnen behindert (Blätter, Äste
- Entfernen Sie Wasser, dass sich an den Füßen der Pergola herum sammelt (heben Sie die Abdeckungen an)

Garantie

Die Garantie umfasst nicht:

- Normale Gebrauchsspuren des Produkts
- Verlust oder Bruch von Teilen beim Auspacken oder bei der Montage
- Mangel an vernünftiger Sorgfalt, Vernachlässigung, Vandalismus, Einwirkung
- Schäden durch Fremdkörper, Gewaltanwendung, Kontakt mit Schleifmitteln oder ästhetische Beeinträchtigungen
- Ausbau, Wiederaufbau oder Verlegung des Standorts.
- Höhere Gewalt: Hagel, starke Winde, Stürme, Schnee, Überschwemmungen, Blitzschlag...
- Veränderung des Produkts durch den Benutzer.

Die Garantie umfasst nur den Ersatz des Ersatzteils oder des gelieferten Produktes, unter Ausschluss jeglicher Kosten und Entschädigungen jeglicher Art.

Die Garantie muss bei der Verkaufsstelle (Geschäft oder Internetseite) beantragt werden, bei der Sie Ihr Produkt gekauft haben.

Teileliste pro Karton

Bevor Sie mit dem Aufbau beginnen, bitten wir Sie alle aufgeführten Bauteile auf Vollständigkeit zu prüfen. Zudem bitten wir Sie nachzuschauen, dass keine Schäden an den Teilen vorhanden sind. Fehlende oder beschädigte Teile müssen binnen 10 Werktagen nach Anlieferung beim Hersteller reklamiert werden.



Sie können hierzu gerne unseren Kundenservice kontaktieren.

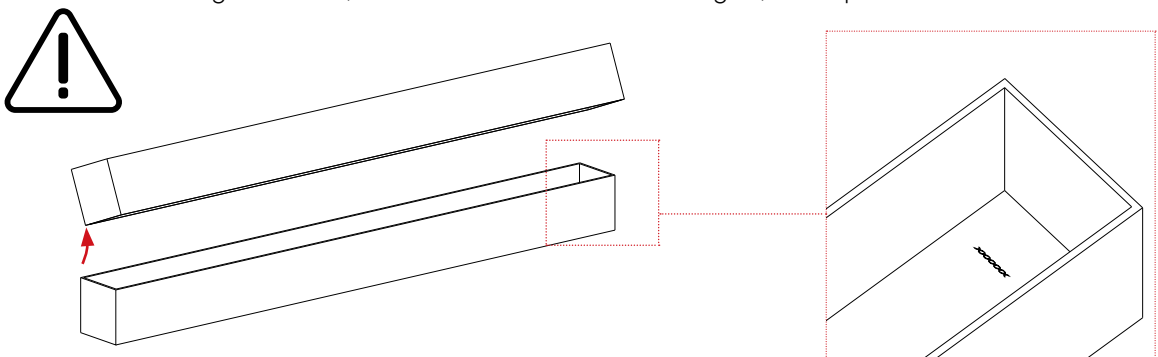

Entsorgen Sie die Verpackung nicht, ohne sicherzustellen, dass das Produkt richtig funktioniert.



Auf der Innenseite des Kartons befindet sich eine Produktverfolgungsnummer (siehe Abbildung unten). Für einen besseren und effizienteren Kundendienst in der Zukunft machen Sie bitte ein Foto der Tracking-Nummer, bevor Sie den Karton entsorgen, und speichern Sie dieses.







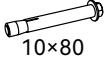



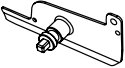
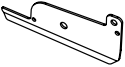



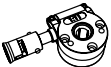













KARTON 1/5

Nr.	Profil	Bild	Maße	Menge
AO			136X136 L=2550mm	4



Nr.	Bild	Menge
IO		4
JO		4



Nr.	Bild	Menge
TO	 10x80	16
XO-1	  6x35 4mm	16

Nr.	Bild	Menge
KO		1
LO		24
LO-1		25
MO		49
MO-1		49
NO		1
OO		1
PO		1
QO	  6mm	8
QO-1	  6mm	8
QO-2		8
QO-3		8

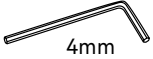

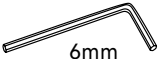

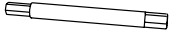



Nr.	Bild	Menge
RO		16
SO		50
UO	 lock nut	74
UO-1	 plastic nut	25
VO		124
WO	  4x16 PH2	100
XO	  6x40 4mm	49
XO-2	  6x20 4mm	25
YO	  6x45 4mm	3

KARTON 1/5

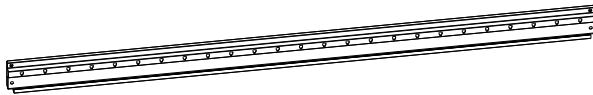
Nr.	Bild	Menge
ZO-1	 4mm	1
ZO-2	 4mm	1
ZO-3	 6mm	1

Nr.	Bild	Menge
ZO-4	 6mm	1
ZO-5	 10mm	1
ZO-6	 PH2	1

KARTON 2/5

Nr.	Profil	Bild	Maße	Menge
BO			95X195 L=3809mm	1
BO-1			95X195 L=3809mm	1
CO			95X195 L=3809mm	2
FO			27X8 L=3650mm	1
HO			L=1300mm	1





ATTENTION!

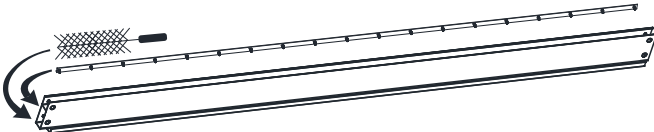

Verbindungsstangen (FO) und Bürste innen!





KARTON 3/5

Nr.	Profil	Bild	Maße	Menge
GO			166X38 L=3770mm	9

KARTON 4/5

Nr.	Profil	Bild	Maße	Menge
GO			166X38 L=3770mm	9

KARTON 5/5





Nr.	Profil	Bild	Maße	Menge
GO			166X38 L=3770mm	7

Montageanleitung

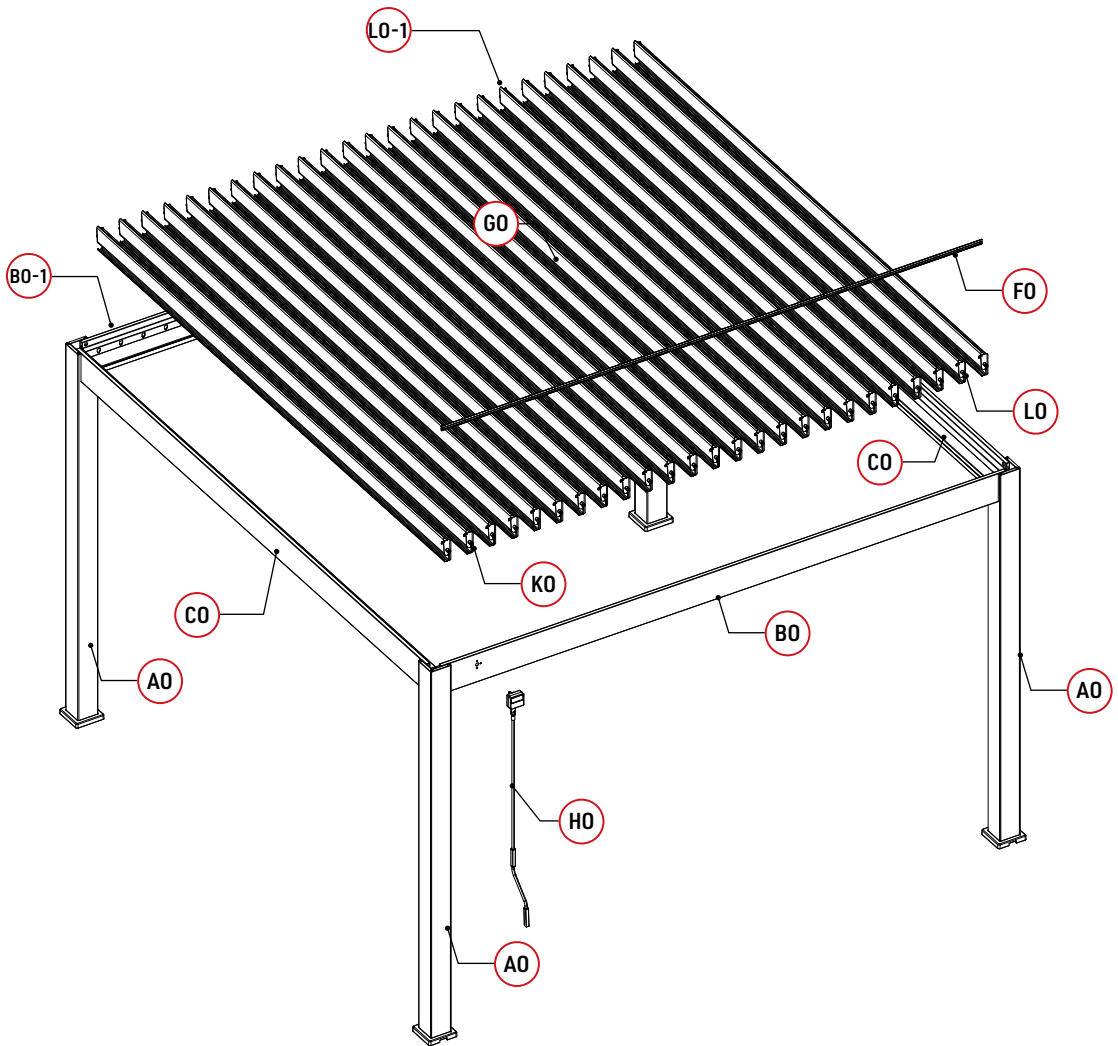

- Schritt 1: Rahmen
- Schritt 2: Lamellen
- Schritt 3: Verbindungen

MONTAGEBILD

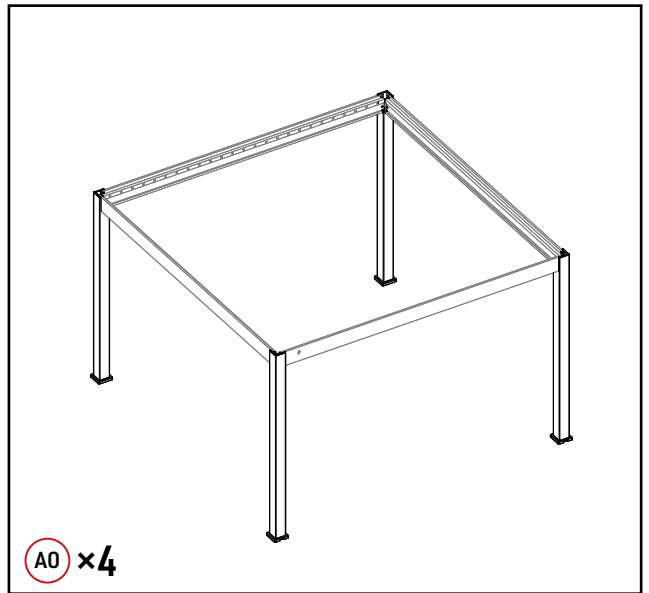

A0		4
I0		4
J0		4
X0-1	 6x35 4mm	16



Z0-1	 4mm	1
Z0-2	 4mm	1



A0 x4

Diagramm zur Fertigstellung.

1.

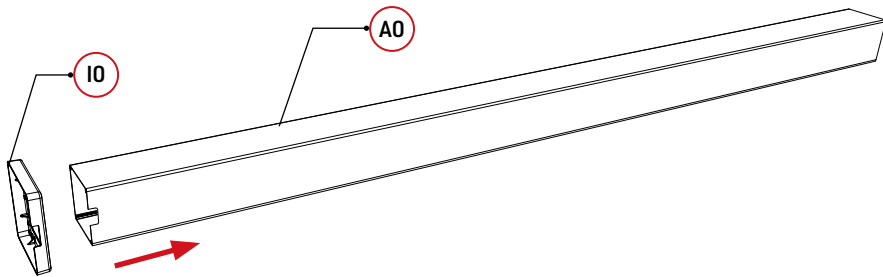



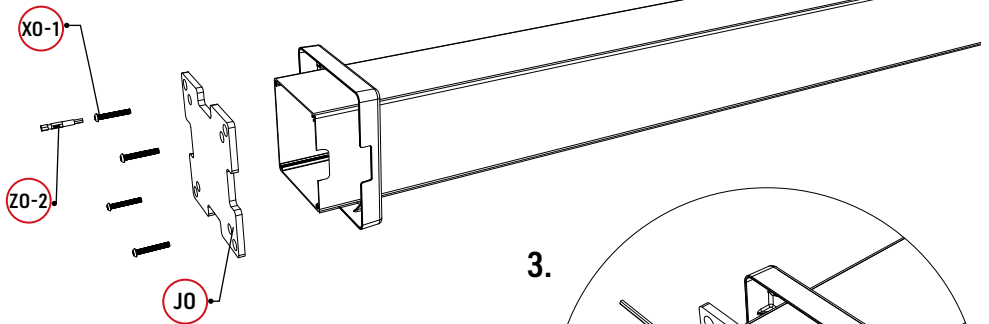

2.

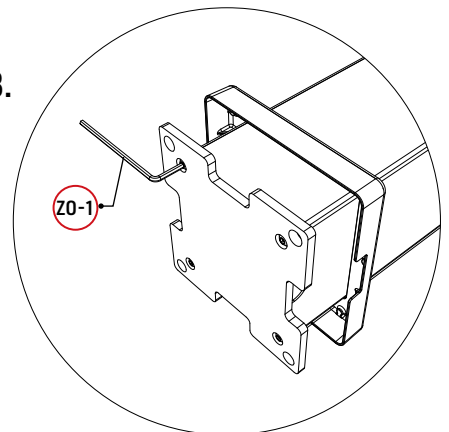



3.



CO		2
----	--	---

QO		6mm	4
QO-1		6mm	4
QO-2			4
QO-3			4

ZO-3		6mm	1
ZO-4		6mm	1

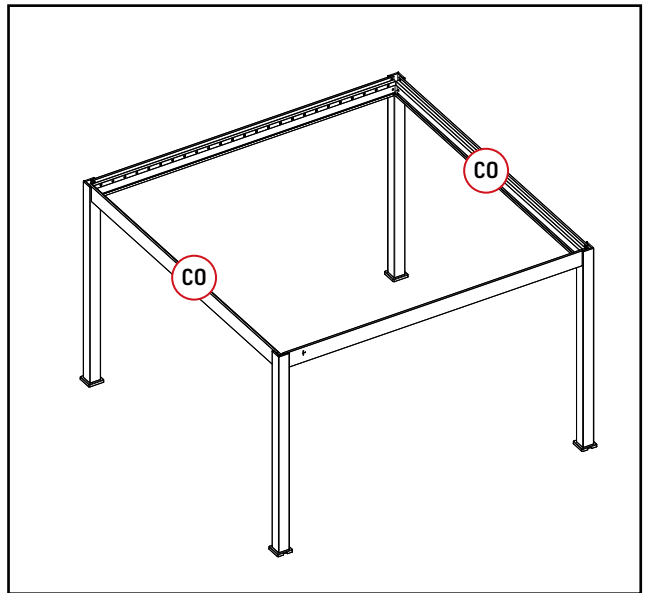

Balken mit Pfosten verbinden.

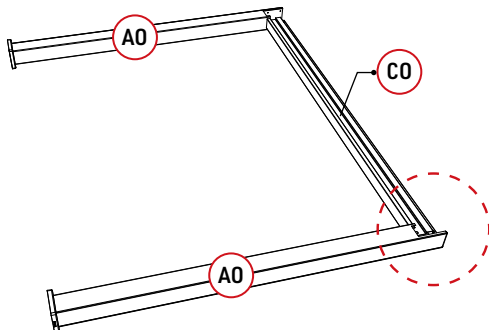
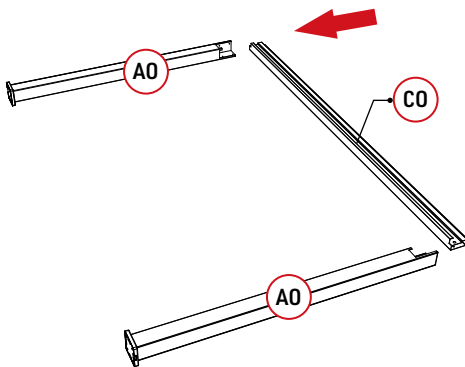



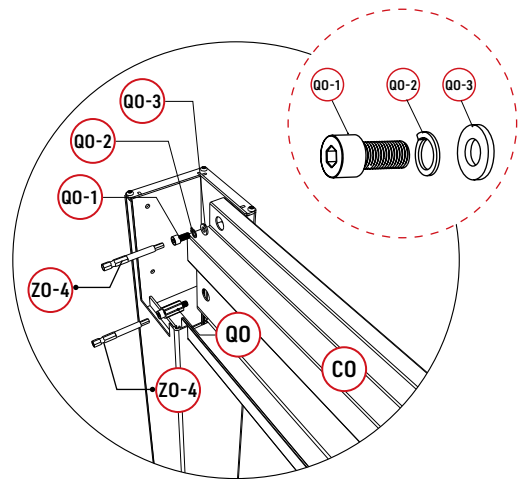

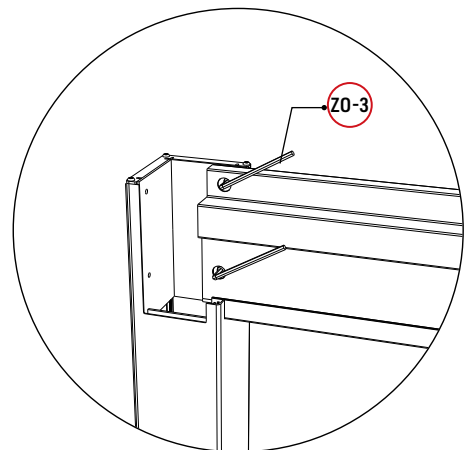

1.





2.



B0		1
B0-1		1

Q0		4
Q0-1		4
Q0-2		4
Q0-3		4

Z0-3		1
Z0-4		1

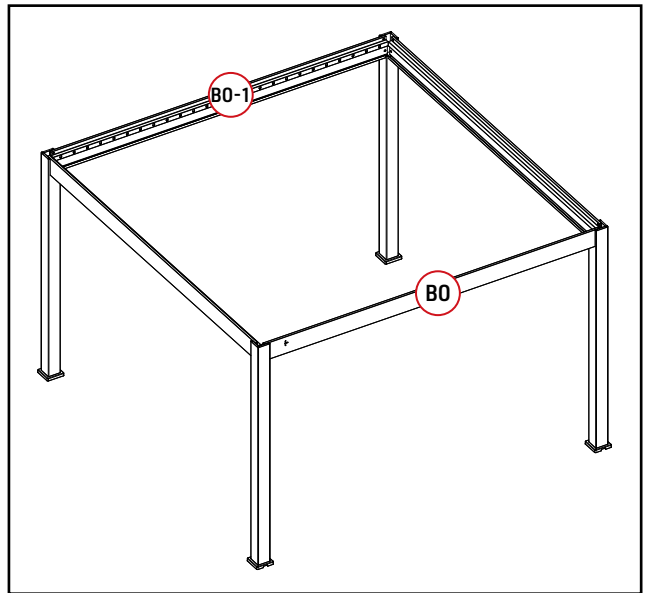

Balken mit Pfosten verbinden.

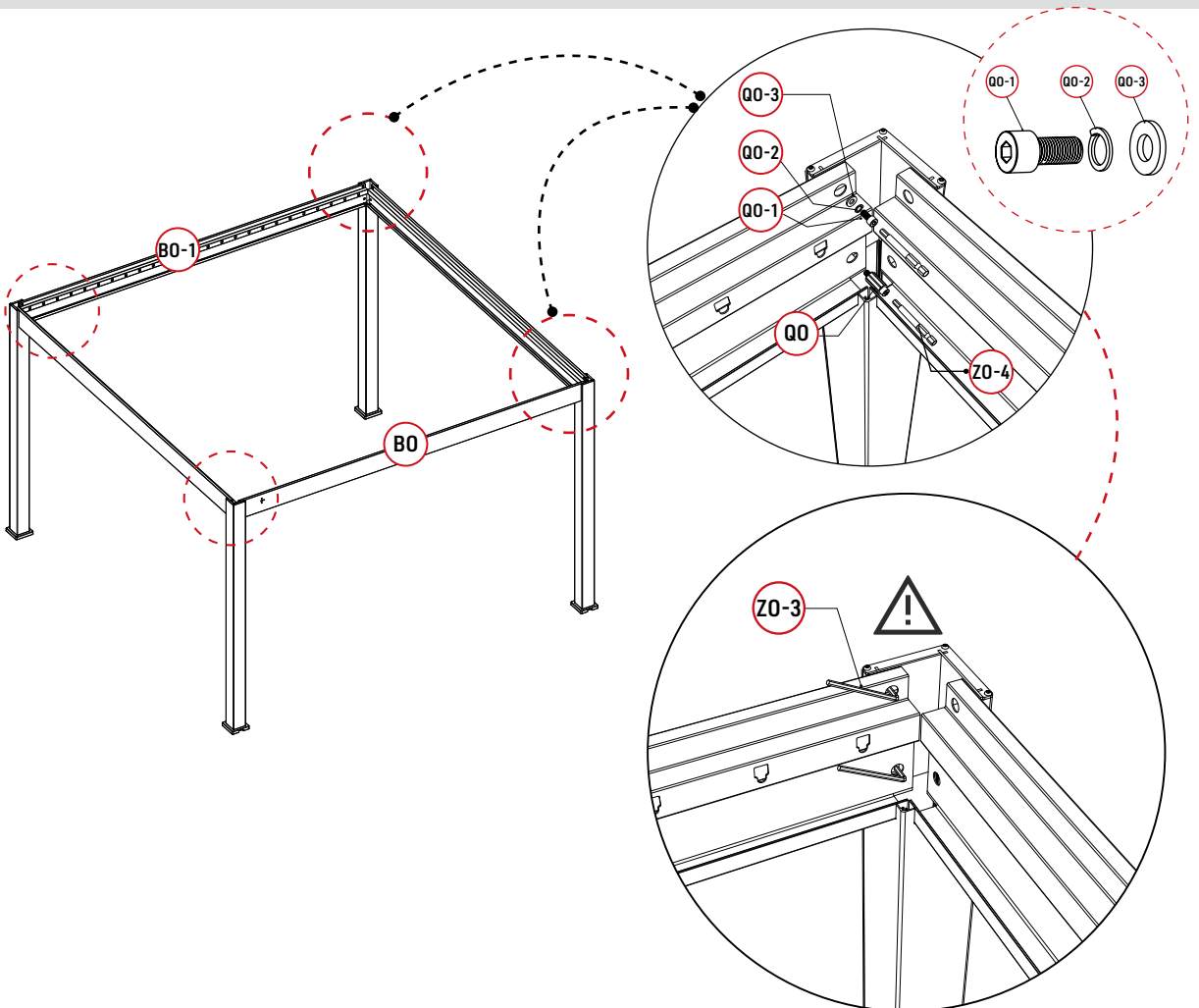

LO		24	MO-1		49	VO		49
LO-1		25	XO		49			
MO		49	UO		49			

ZO-3		1
ZO-4		1

Die Abbildung zeigt einen manuellen Schraubenschlüssel, der durch einen elektrischen P-Bit ersetzt werden kann.



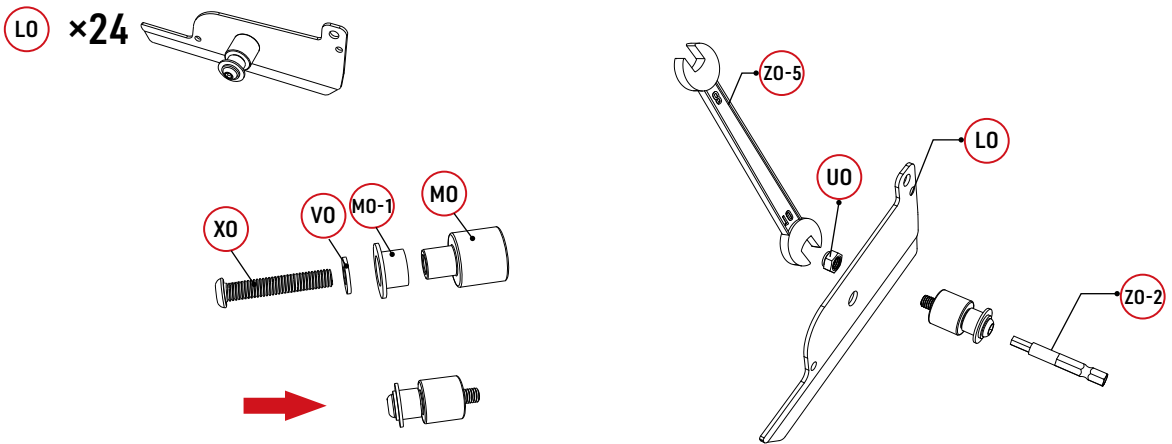

Montieren Sie die Antriebe für die Lamellenabdeckung auf beiden Seiten der Lamellen.
Hinweis: Um ein Brechen der Kunststoffteile (MO) zu vermeiden, verringern Sie bitte die Drehkraft des Akkuschaubers, wenn Sie ihn verwenden.

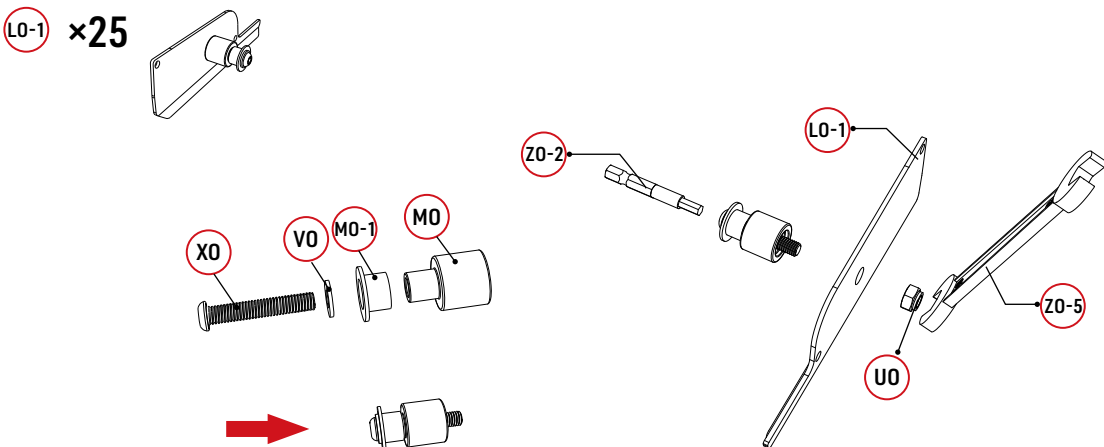



Lamellen-Dichtungsplatte



GO		25
----	--	----

KO		1
LO		24
LO-1		25
WO	 4x16 	100

ZO-1	 4mm	1
ZO-2	 4mm	1
ZO-6	 PH2	1

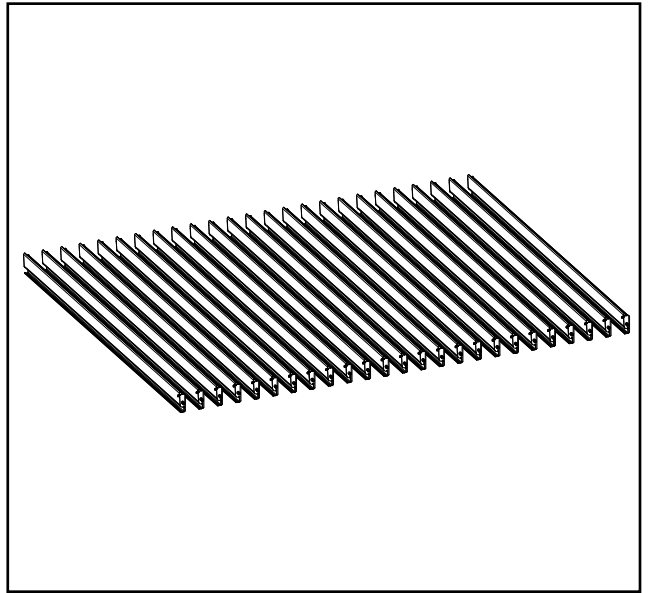

Anschluss der Lamellen.

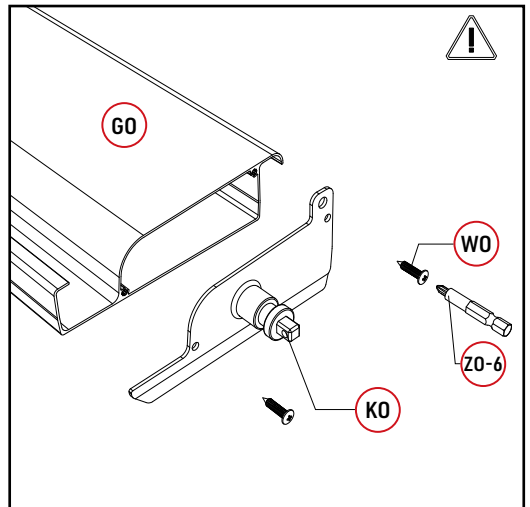
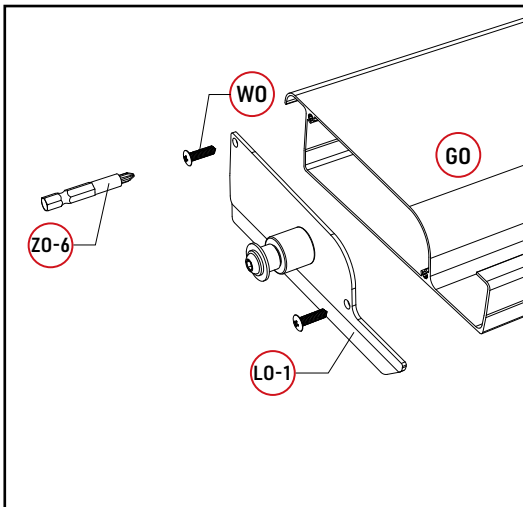
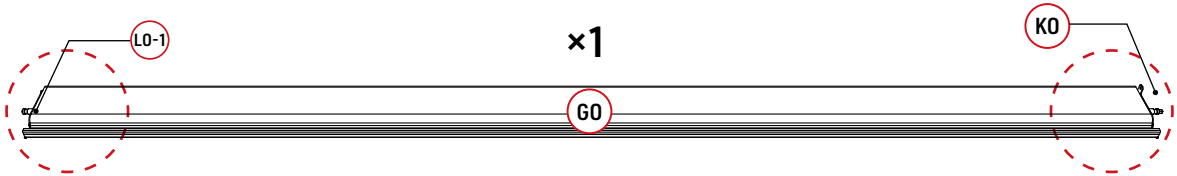

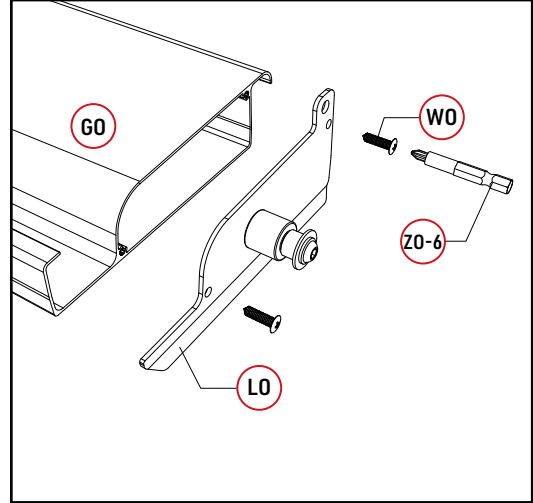
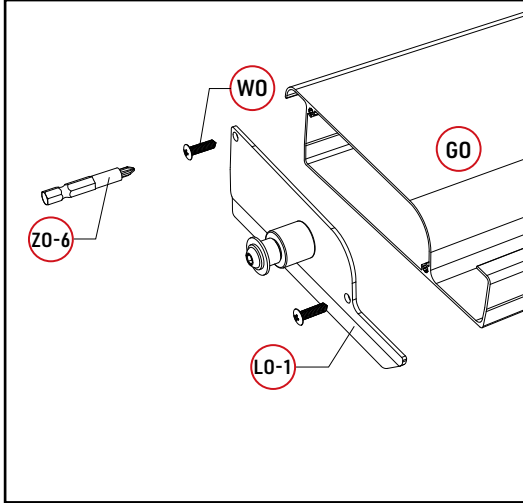
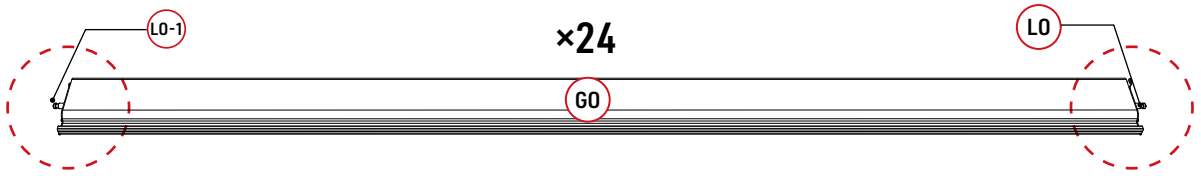

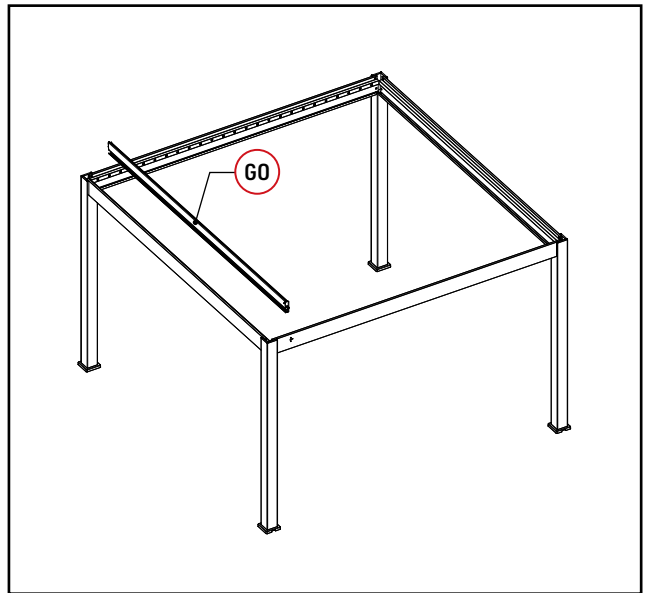

Befestigen Sie die Gummistopfen an beiden Enden der Lamellen.

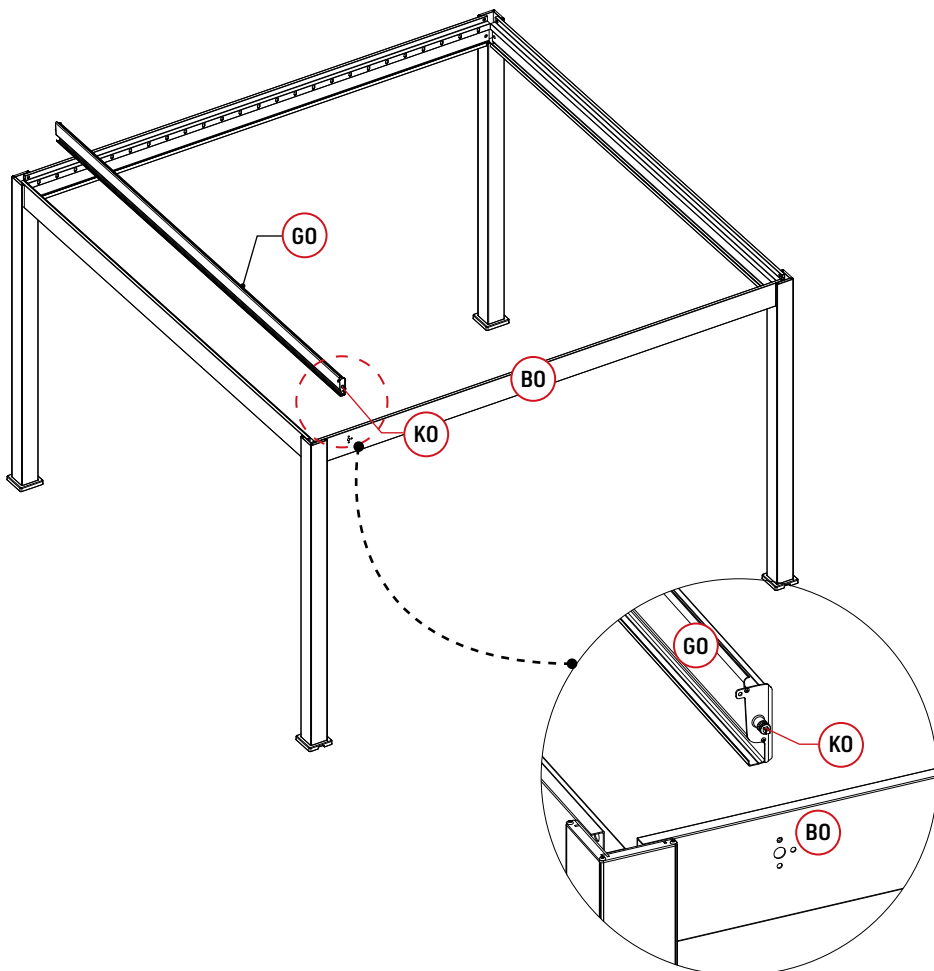

1

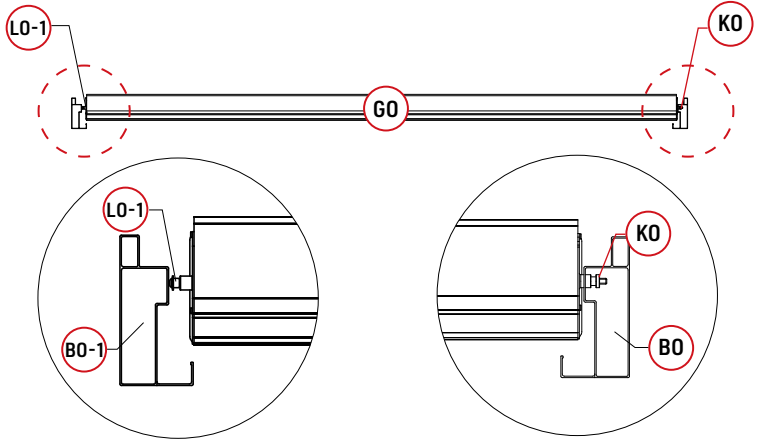
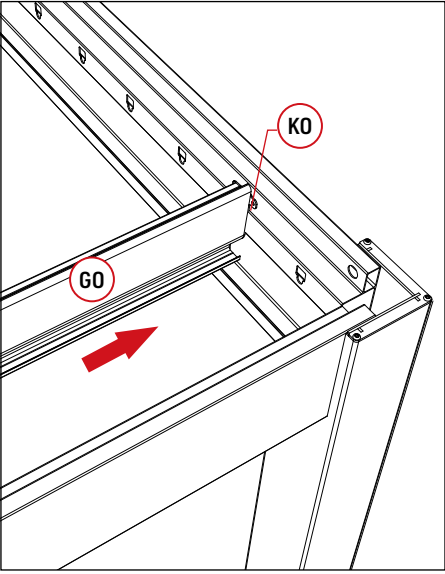

2

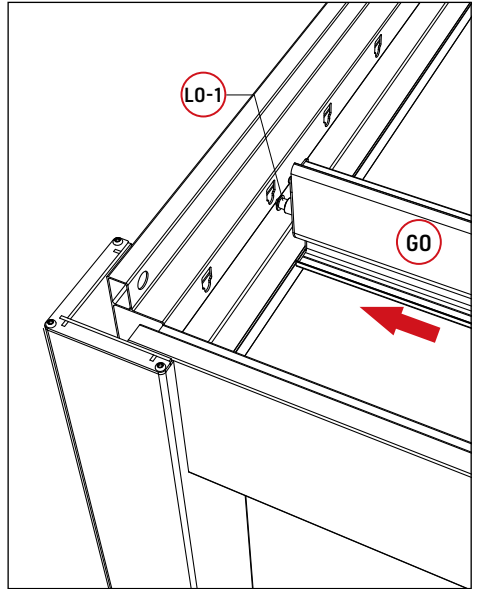
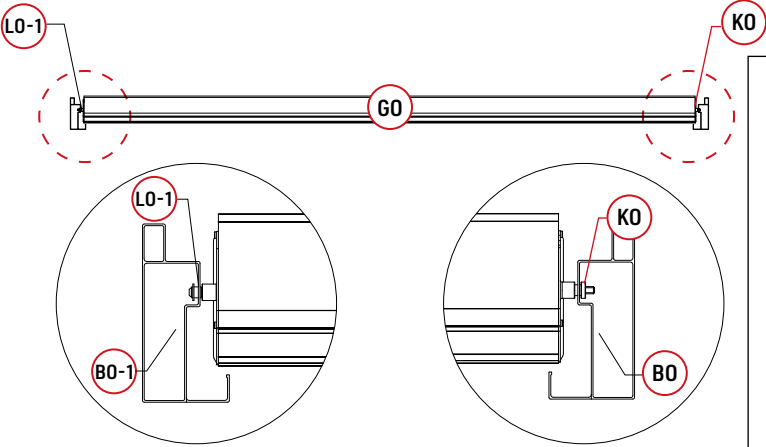

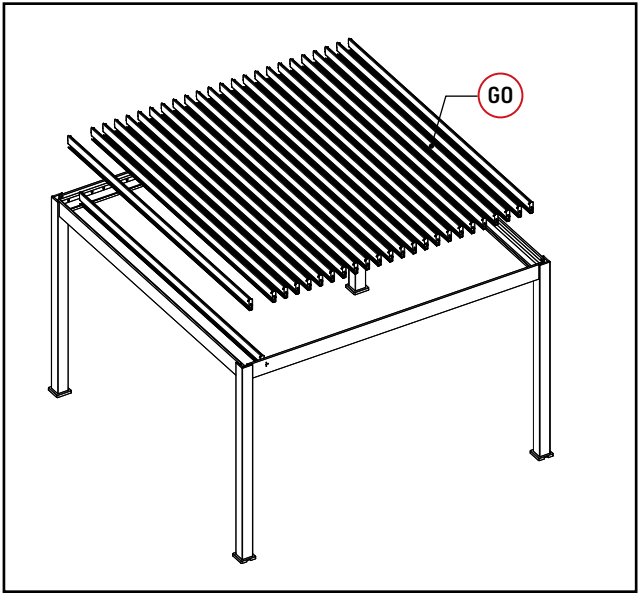





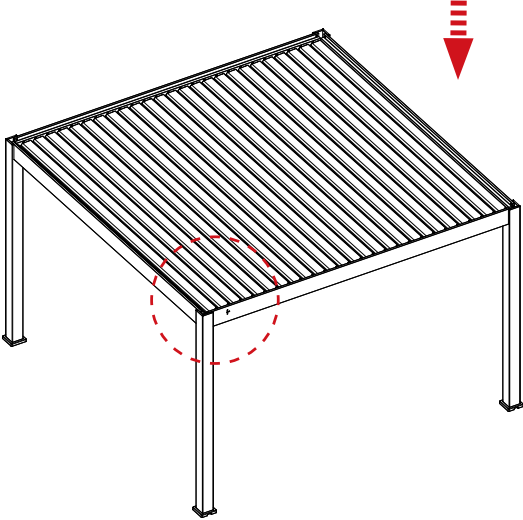

Setzen Sie die anderen Lamellen ein und verschließen Sie die Endkappen.

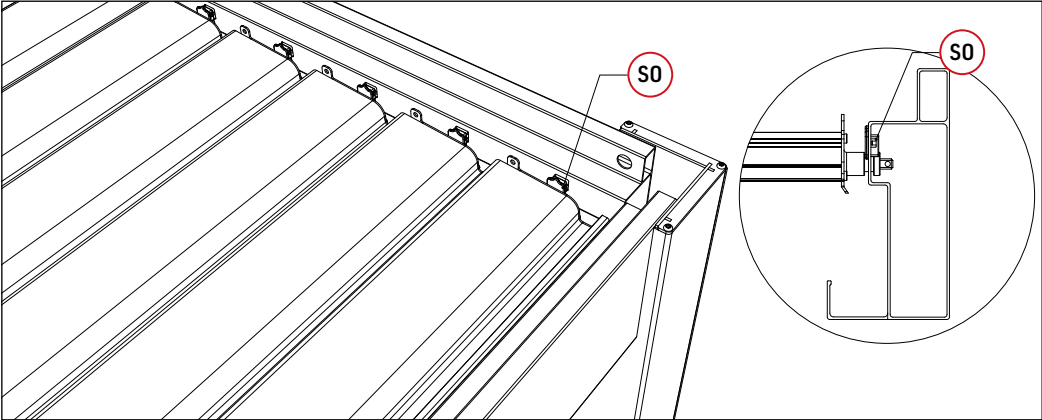
1





2

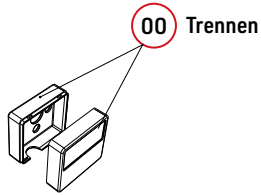
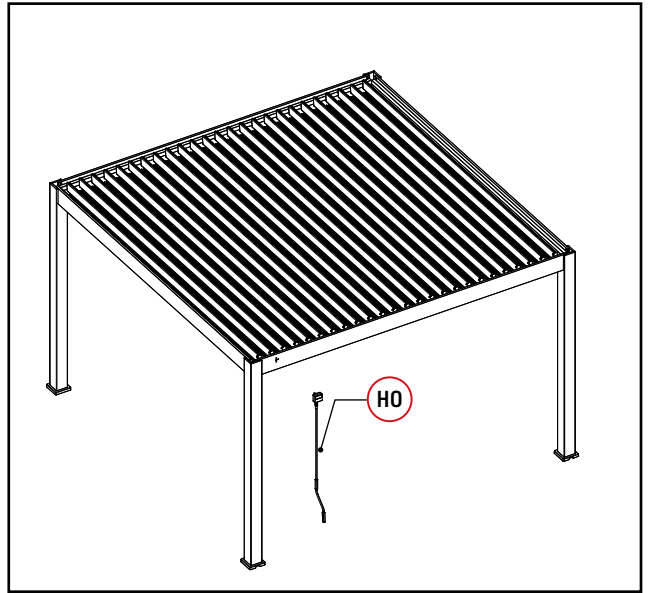

HO		1
NO		1
OO		1
PO		1
YO		3



ZO-1		1
ZO-2		1

Schließen Sie die Verbindung der Lamellen ab.



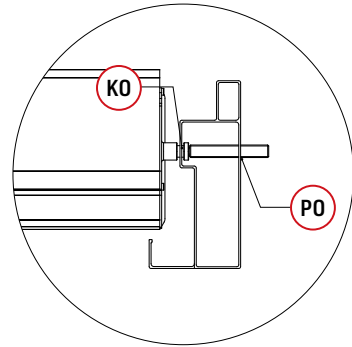
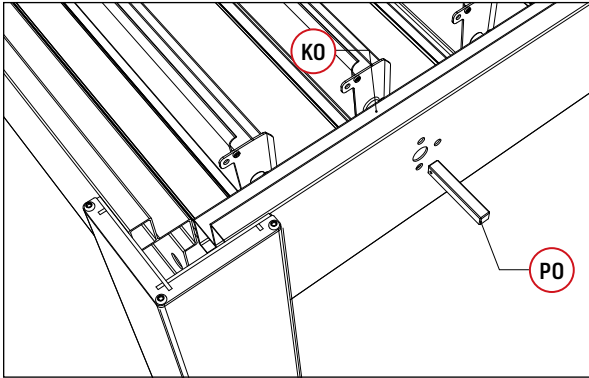

1

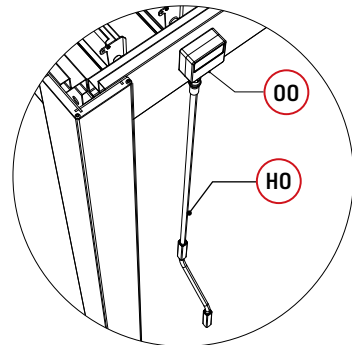
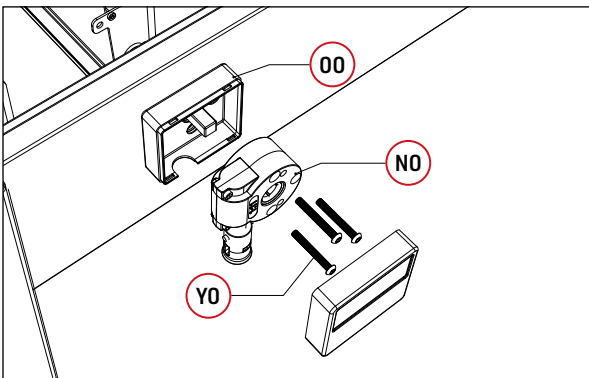





2

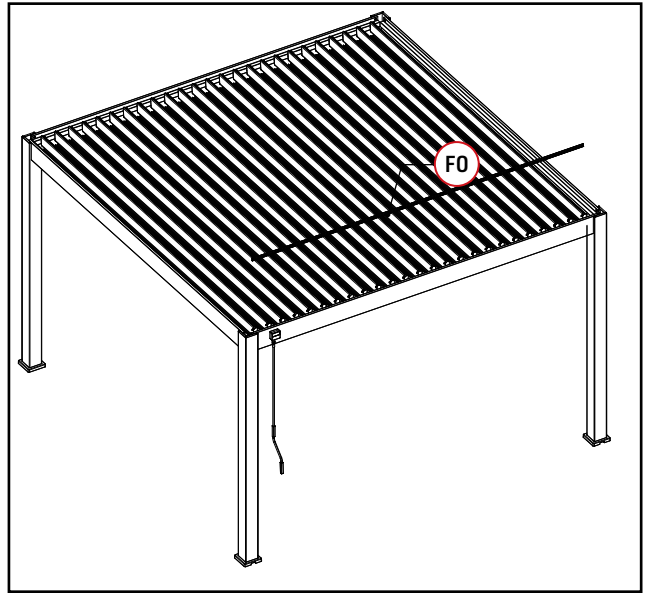

F0		1
----	--	---

X0-2		25
V0		75
U0		25
U0-1		25





Z0-1		1
Z0-2		1
Z0-5		1

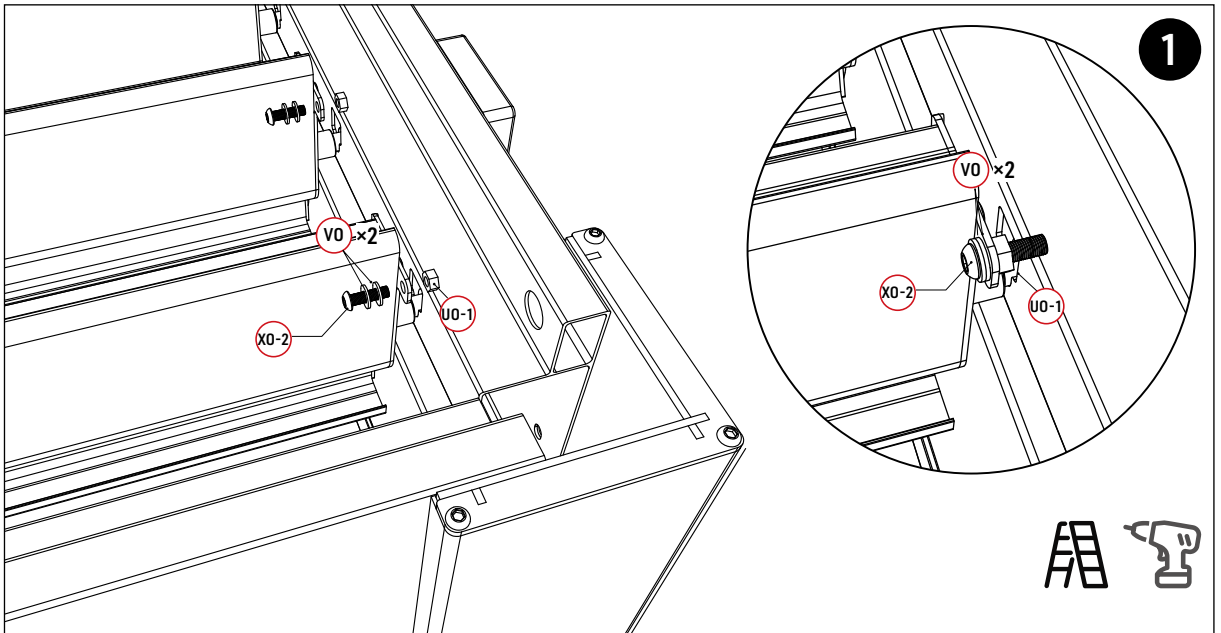

Schließen Sie die Verbindung der Lamellen mit dem FO-Teil ab.

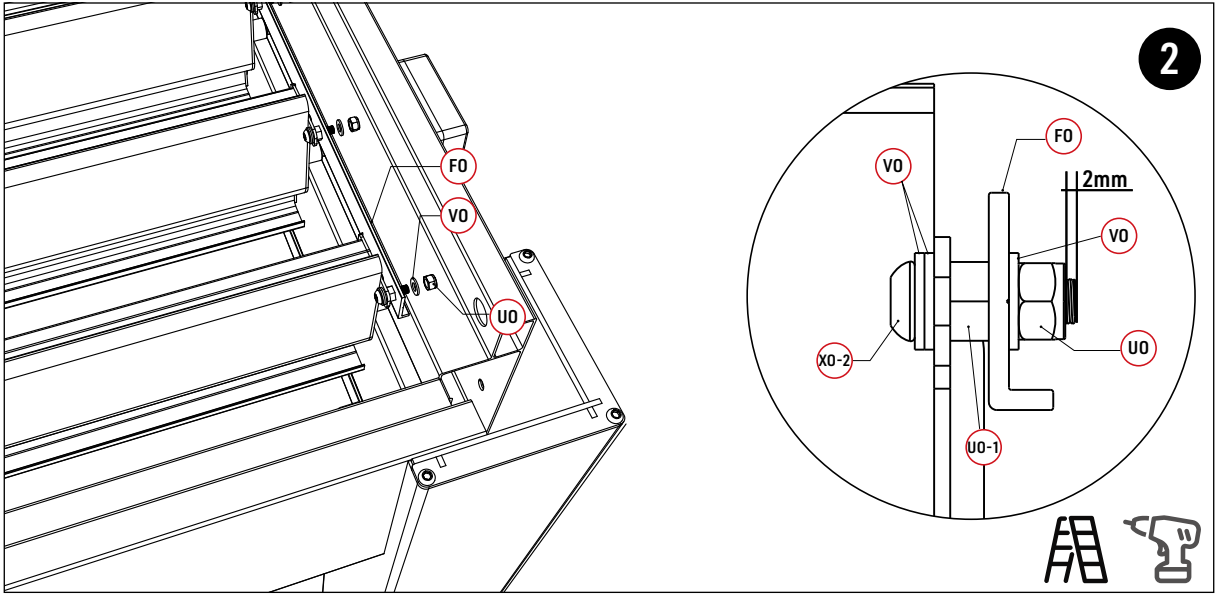



R0		16
T0	 10x80	16

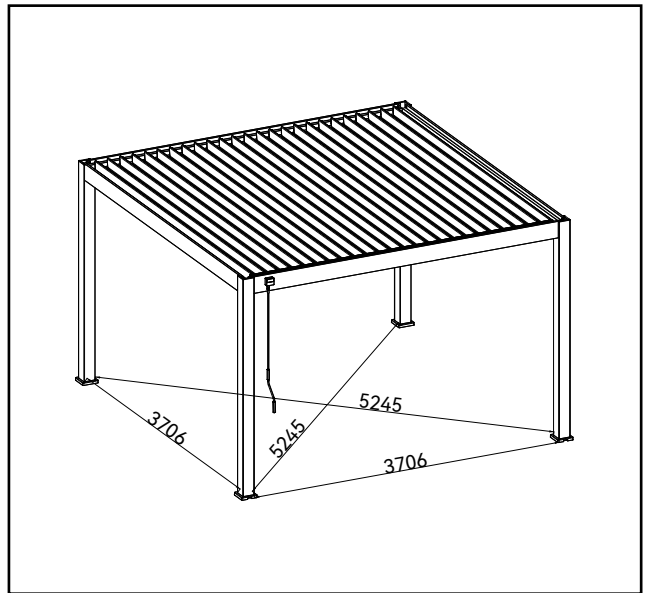

Schließen Sie die Abdeckung, um die Befestigung der Pergola zu beenden.

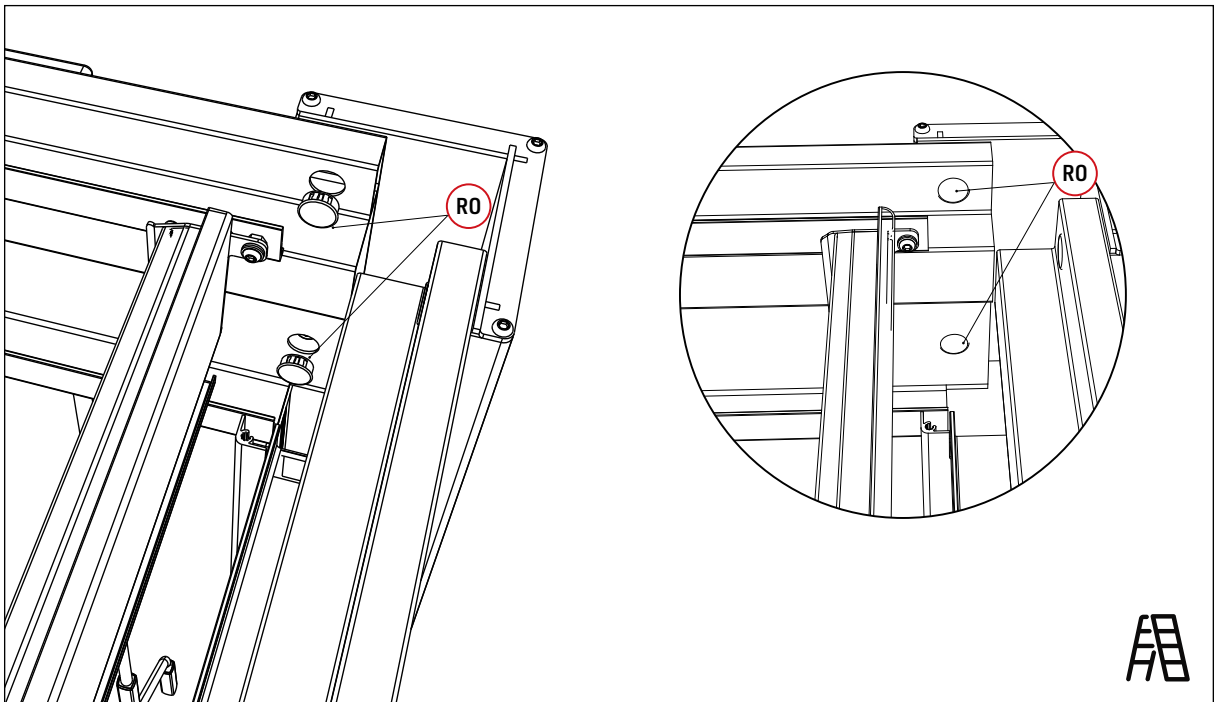

Nach Überprüfung der Maße die Dehnschrauben auf der Platte befestigen.

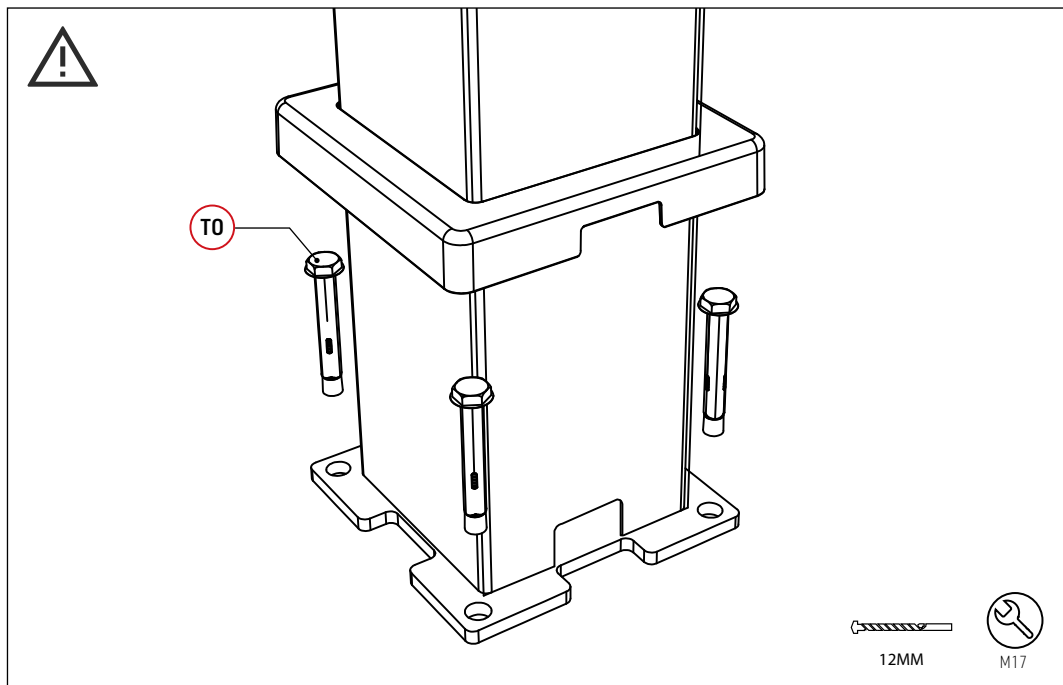

Bewegen Sie die Unterseiten der Pfosten entsprechend den Maßen auf der Titelseite, um sicherzustellen, dass die Abstände gleich sind. Verwenden Sie dann einen 12-mm-Schlagbohrer, um die Löcher vorzubohren. Setzen Sie anschließend die Dehnschrauben ein und ziehen Sie diese mit einem M17-Schlüssel fest.

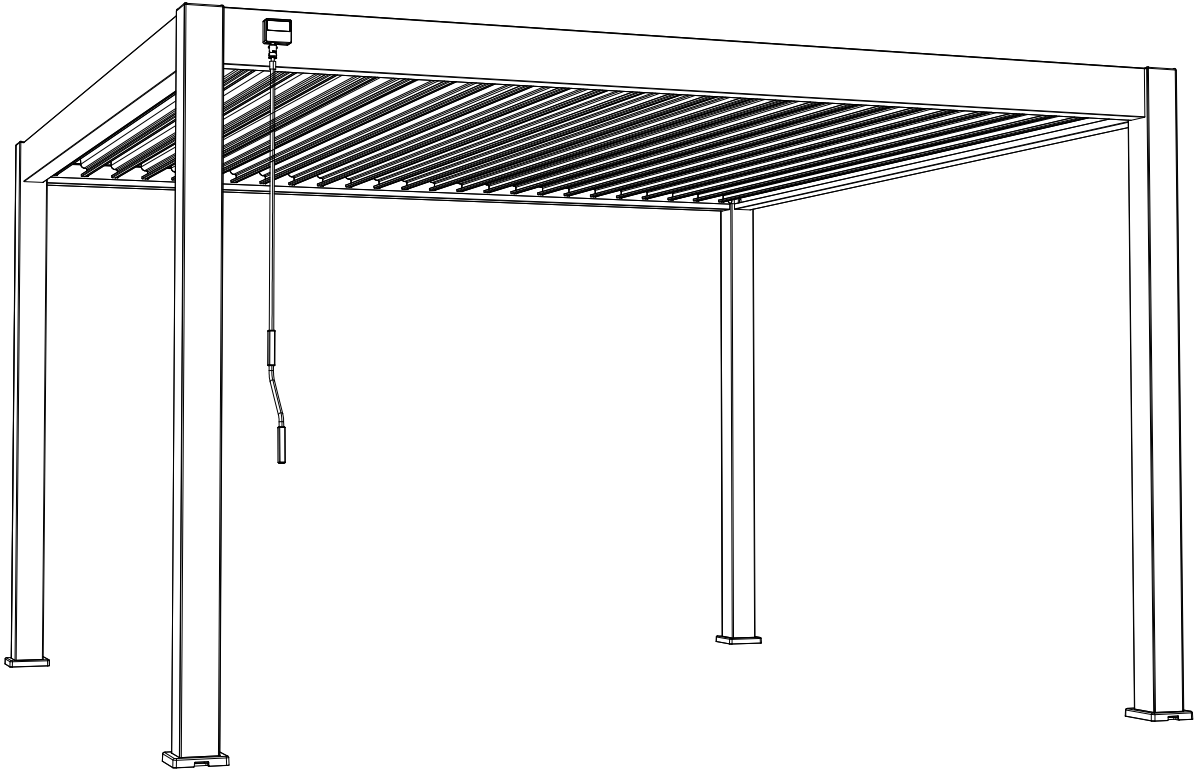

Pergola 4x4M Aluminium

Assembly Instructions - EN

NECESSARY TOOLS AND SAFETY GEAR(NOT SUPPLIED)

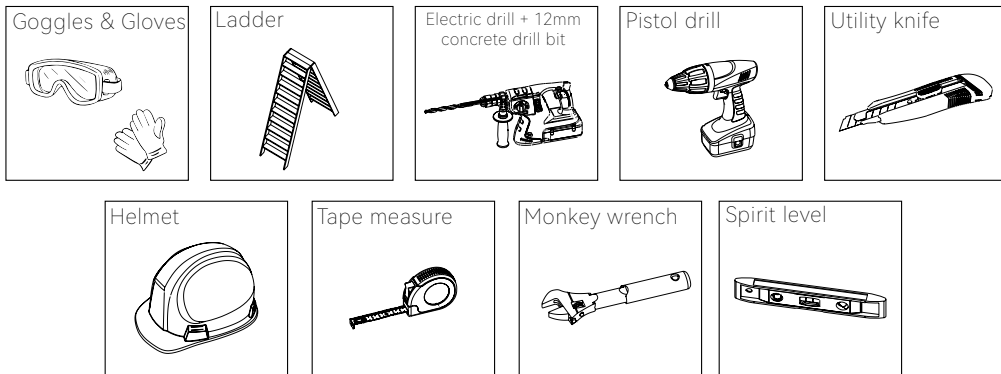

2D FOOTING MEASUREMENT (dimensions in mm)

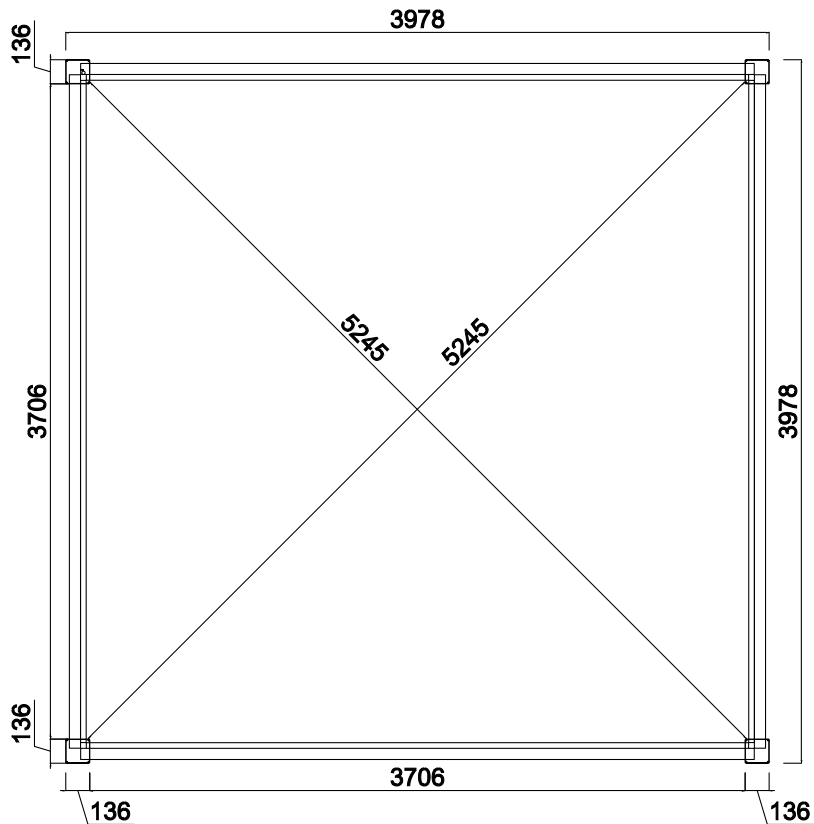

3D FOOTING MEASUREMENT (dimensions in mm)

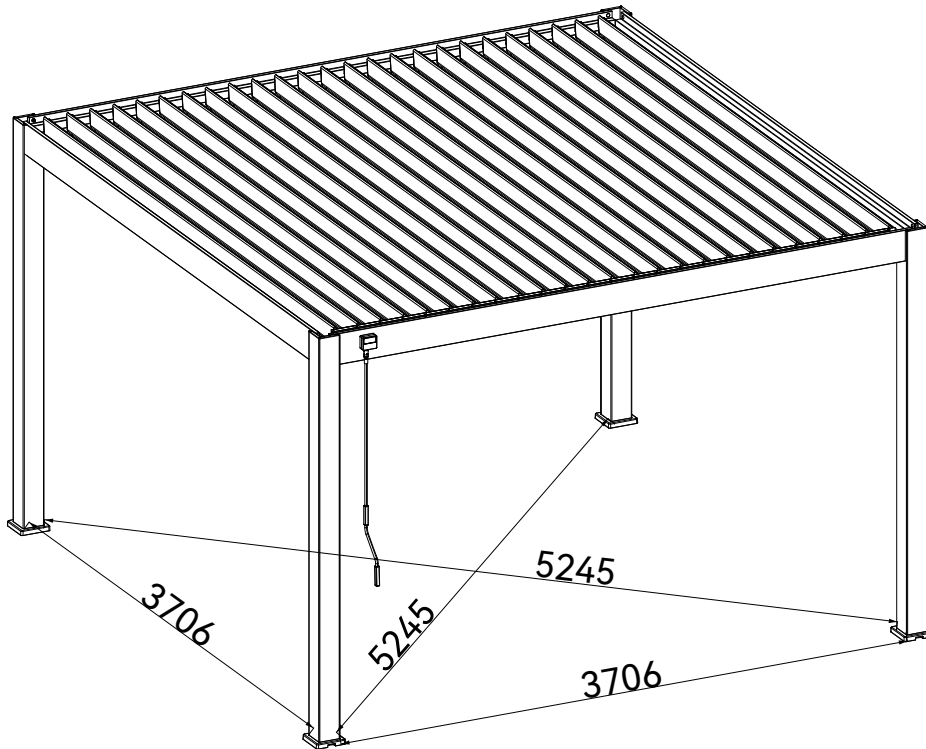

PRECAUTION OF USE

This product should not be used in extreme weather: storms, violent winds, hail, and snow. We guarantee the resistance of the pergola for winds up to 100 km/h and a maximum snow weight of 70kg/m².

As in the case of strong winds or snow, we highly recommend leaving the louvers open. To maintain good working conditions of your louvers, please clear any snow on them.

Our pergola can withstand heavy rain, but we cannot guarantee it will be 100% waterproof due to some extreme weather conditions.

Exceptional climatic events may compromise the perfect sealing of the product.

To avoid any damages and injuries, we do not recommend climbing on the roof or the structure of the pergola.

TIPS AND SAFETY INSTRUCTIONS

Depending on the location and surface area, construction may be subject to building permits. Make sure you have checked with your local authorities to obtain the needed information before the assembly.

Product assembly :

- At least 2/3 people required
- Remove protective film (around 1 hour needed)
- Do not keep children near the assembly area
- Beware of the risk of pinching
- Do not tighten the screws before assembling the whole product
- All assembly steps must be carefully followed
- Check the level of the structure on all sides
- Do not anchor the pergola before assembling the whole product

No changes can be made to the product. Products tampered with by the user are not covered by the warranty, thus being declared as void.

The location should be chosen carefully. It is recommended to avoid mounting your pergola on a rainy day, facing the prevailing winds, and under an overhanging tree.

The pergola must be mounted on a flat-level foundation. It is recommended to install it on a concrete slab or 25x25 cm concrete pads at each post. Please, anchor the pergola properly to the ground using expansion screw.

If you would like to mount your pergola near your house or a building, please check the presence of gutters for water drainage.

Should these instructions not be followed or only partially, the warranty will be voided by the seller.

MAINTENANCE

Regular maintenance is necessary to ensure its longevity and aesthetic appearance.

We recommend to :

- Clean your pergola once or twice a year with fresh water using a sponge or cloth.
- Do not use detergent or an abrasive material.
- Check the tightness of the screws regularly (at least once a year).
- Oil fastening regularly (at least once a year).
- Make sure that nothing hinders the water flow in the gutters (leaves, branches...).
- Remove any water that might stagnate around the legs of the pergola (lift the posts skirts).

WARRANTY

This warranty does not cover :

- Normal wear and tear inherent from the products.
- Loss or breakage of any part during unpacking or installation.
- Lack of care, neglect, vandalism, impact with foreign body, force, contact with a abrasives material, product aesthetics, disassembly, rebuilding or relocation.
- Force majeure: hail, high winds, storms, snow, floods, lightning etc...
- Product tampered with by the user.

The warranty only takes in account the replacement of spare Diagram or the provided product, no refund will be issued.

All warranty claims must be made at the sales outlet (store or website) where the product has been purchased.

PARTS LISTS (PER CARTON)

Before proceeding with the assembly of your louvered pergola, it is necessary to check that all Diagram listed are supplied and not damaged.

Any missing part must be reported within 10 days of delivery.



You can either go through your local outlet store or make the request directly on our website.

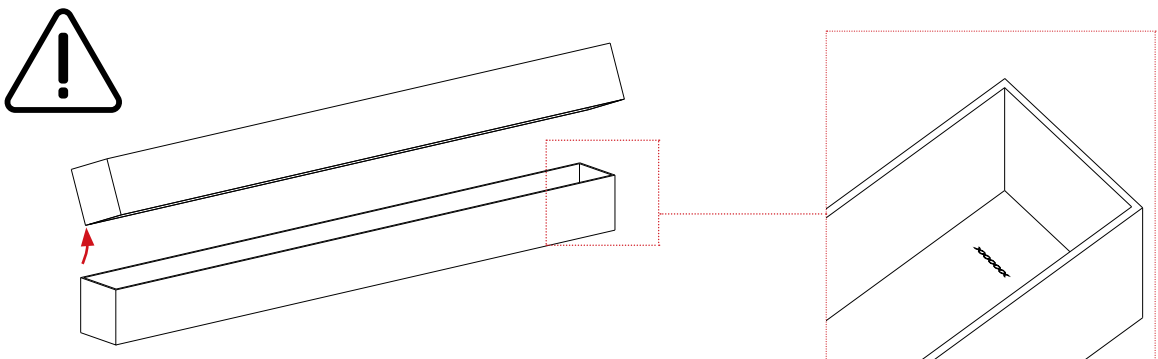

Do not discard the packaging without ensuring that the product is functioning properly.



There is a Product Tracking Number in the inner side of the carton(see below diagram). For better and efficient after-sales in the future, when tear down the carton box, please take a photo of the Tracking Number and save the photo.







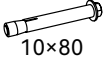



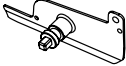
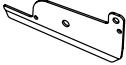
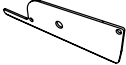

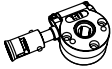

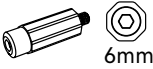



CARTON 1/5

No.	Profile	Diagram	Size	QTY
AO			136X136 L=2550mm	4

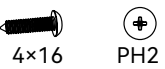

No.	Diagram	QTY
IO		4
JO		4



No.	Diagram	QTY
TO	 10x80	16
XO-1	 6x35 4mm	16

No.	Diagram	QTY
KO		1
LO		24
LO-1		25
MO		49
MO-1		49
NO		1
OO		1
PO		1
QO	 6mm	8
QO-1	 6mm	8
QO-2		8
QO-3		8

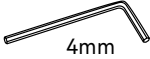

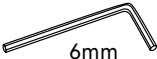

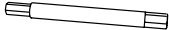



No.	Diagram	QTY
RO		16
SO		50
UO	 lock nut	74
UO-1	 plastic nut	25
VO		124
WO	 4x16 PH2	100
XO	 6x40 4mm	49
XO-2	 6x20 4mm	25
YO	 6x45 4mm	3

CARTON 1/5

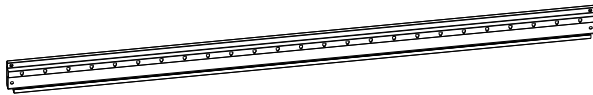
No.	Diagram	QTY
ZO-1	 4mm	1
ZO-2	 4mm	1
ZO-3	 6mm	1

No.	Diagram	QTY
ZO-4	 6mm	1
ZO-5	 10mm	1
ZO-6	 PH2	1

CARTON 2/5

No.	Profile	Diagram	Size	QTY
BO			95X195 L=3809mm	1
BO-1			95X195 L=3809mm	1
CO			95X195 L=3809mm	2
FO			27X8 L=3650mm	1
HO			L=1300mm	1





ATTENTION!

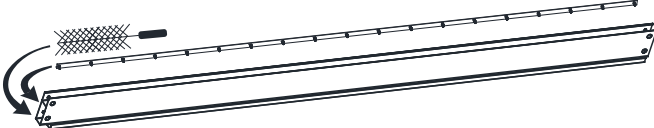

Connecting Bar(FO) & Brush Inside!





CARTON 3/5

No.	Profile	Diagram	Size	QTY
GO			166X38 L=3770mm	9

CARTON 4/5

No.	Profile	Diagram	Size	QTY
GO			166X38 L=3770mm	9

CARTON 5/5

No.	Profile	Diagram	Size	QTY
GO			166X38 L=3770mm	7

ASSEMBLY GUIDELINES





Step 1 : Assembling louvers

Step 2 : Frame

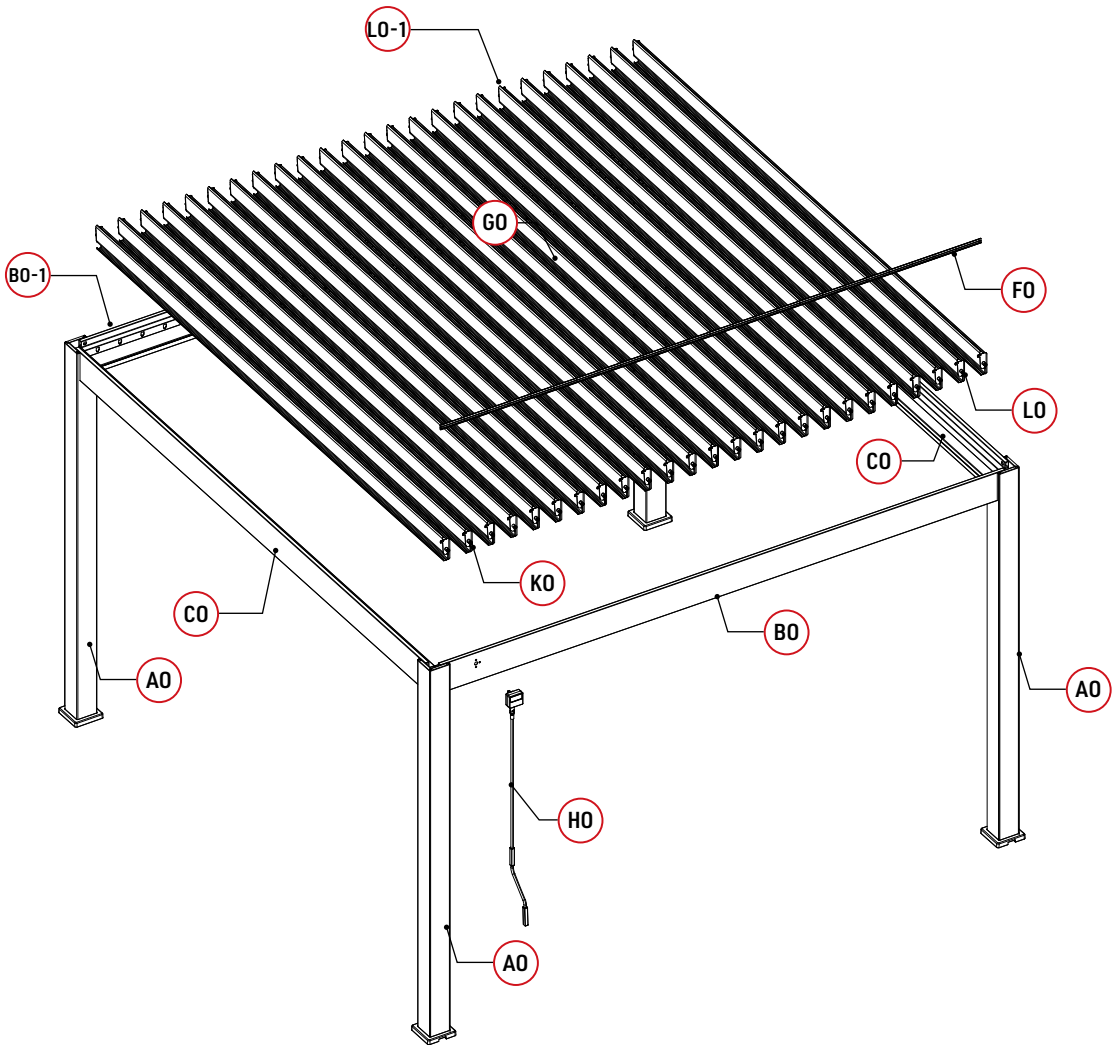

Step 3 : Install louvers & Connection

ASSEMBLING DIAGRAM

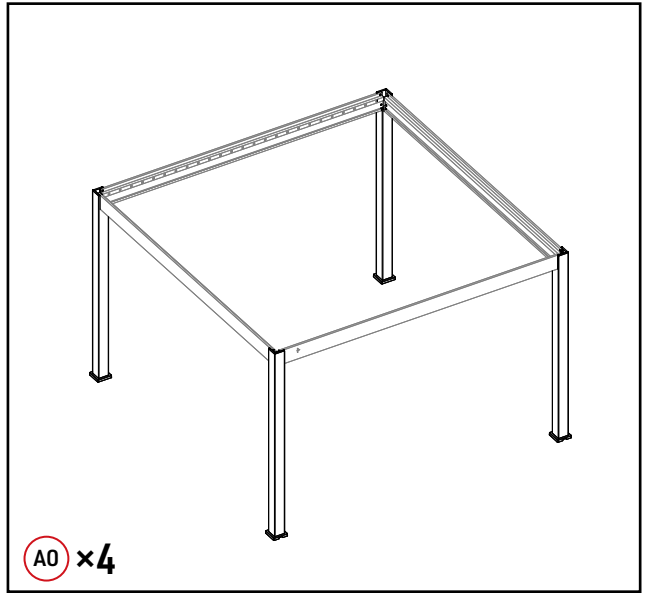

A0		4
I0		4
J0		4
X0-1	 6x35 4mm	16



Z0-1	 4mm	1
Z0-2	 4mm	1



A0 x4

Post installation diagram

1.

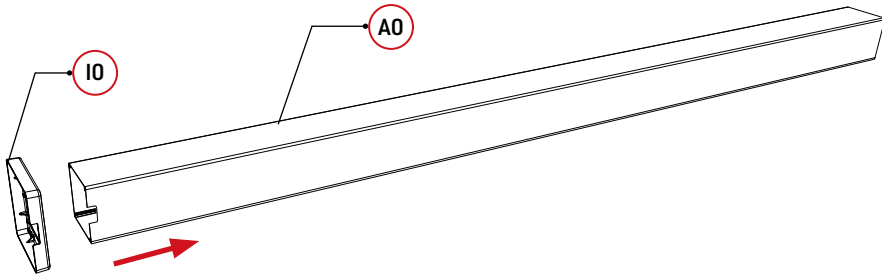



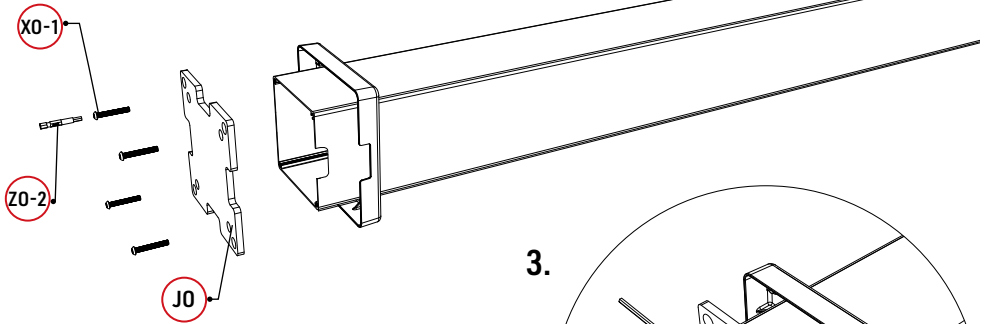

2.

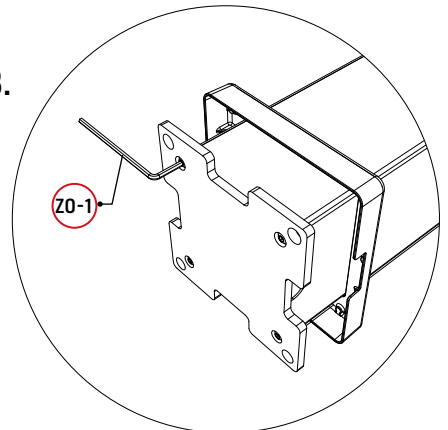



3.



CO		2
----	--	---

QO		6mm	4
QO-1		6mm	4
QO-2			4
QO-3			4

ZO-3		6mm	1
ZO-4		6mm	1

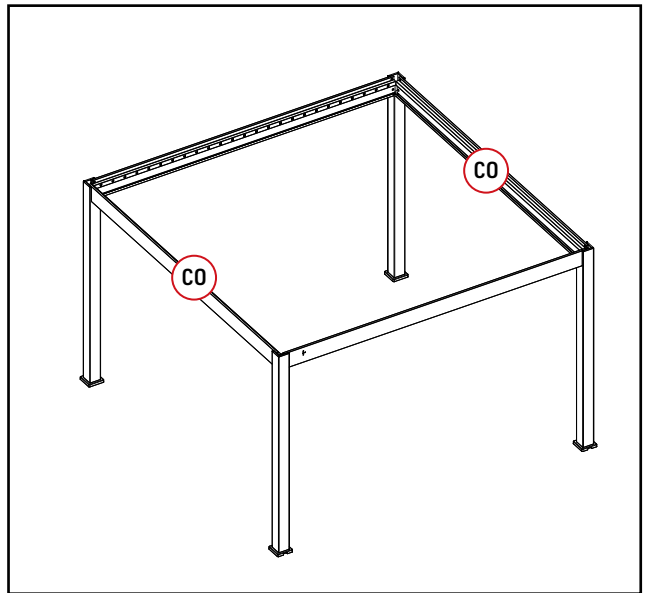

Connect beams to columns

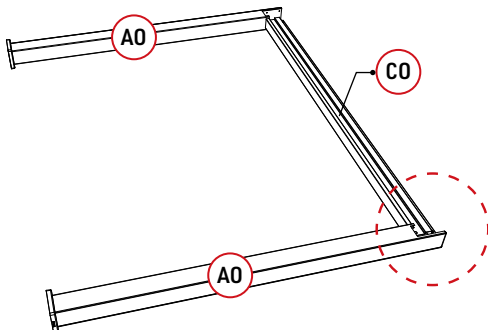
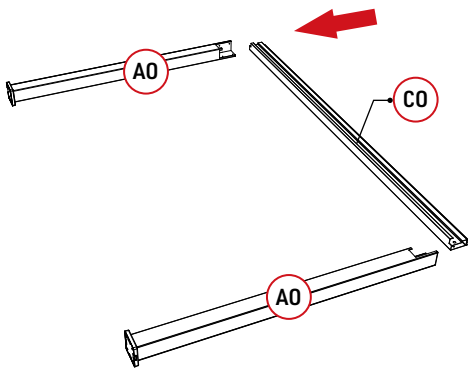



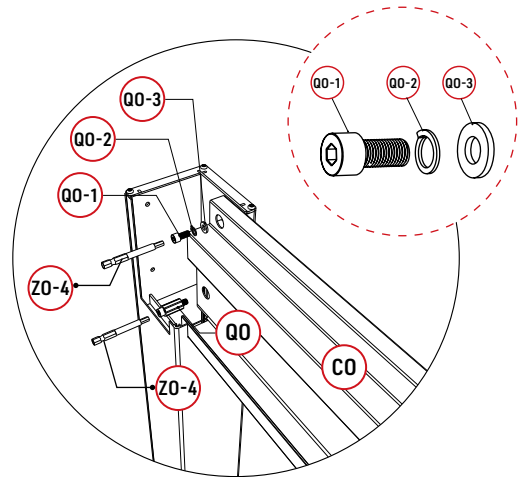

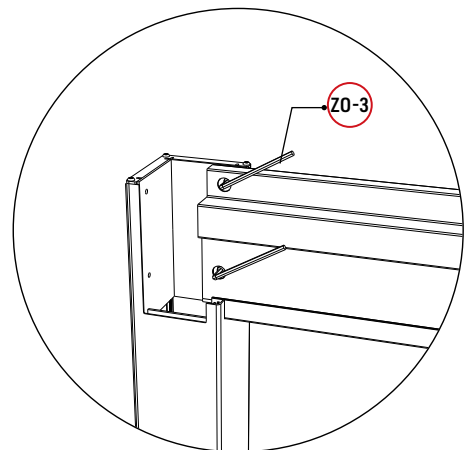

1.



2.



B0		1
B0-1		1



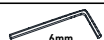
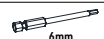

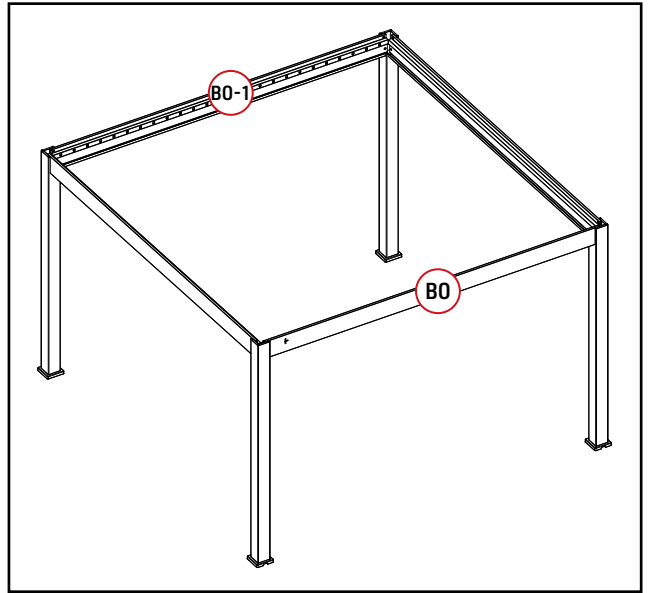

Q0		6mm	4
Q0-1		6mm	4
Q0-2			4
Q0-3			4

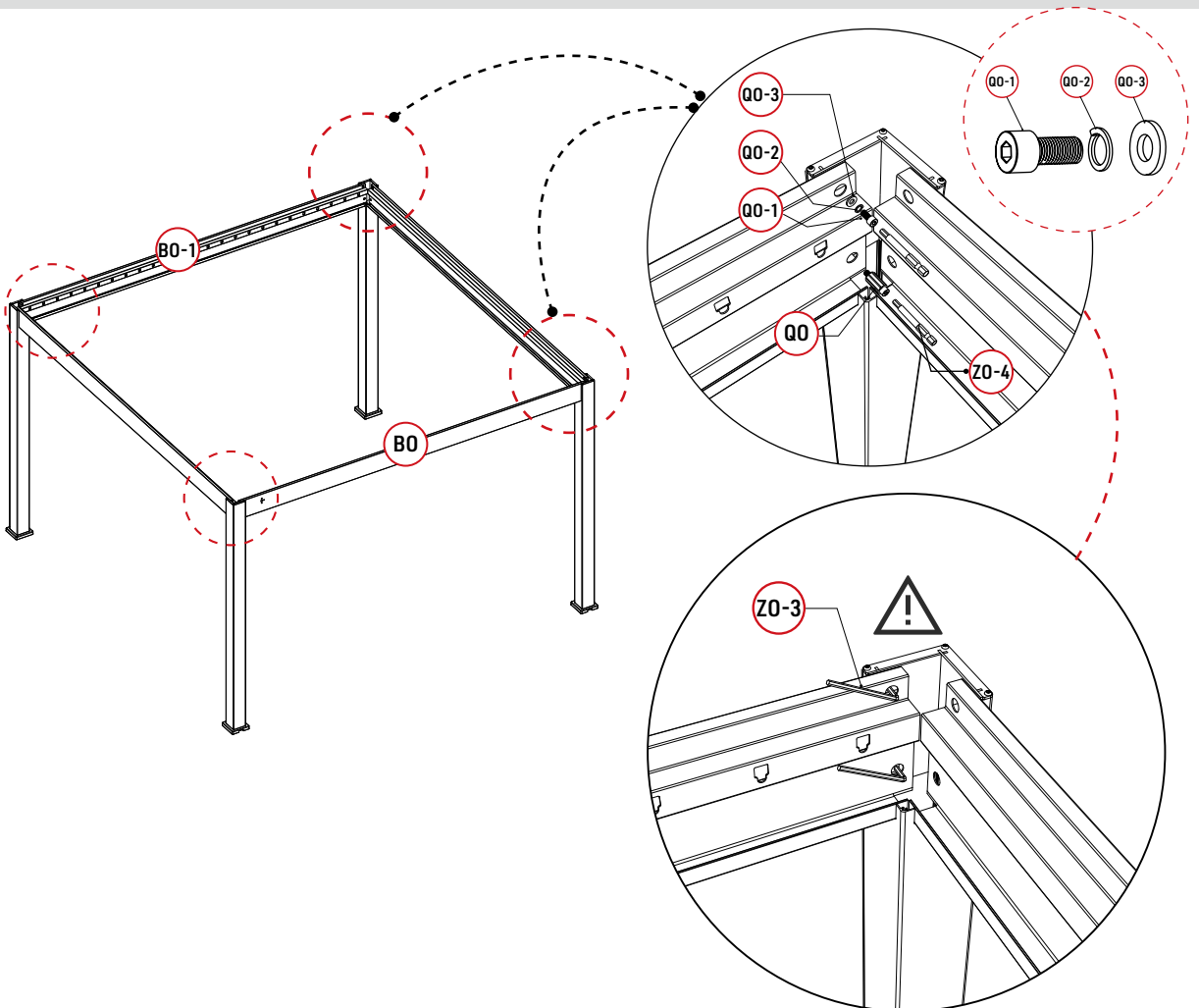

Z0-3		6mm	1
Z0-4		6mm	1



Connect beams to columns



L0		24	M0-1		49	V0		49
L0-1		25	X0	 6-40 4mm	49			
M0		49	U0	 lock nut	49			

Z0-3	 6mm	1
Z0-4	 6mm	1

The illustration uses a manual wrench, which can be replaced with an electric P-tip.



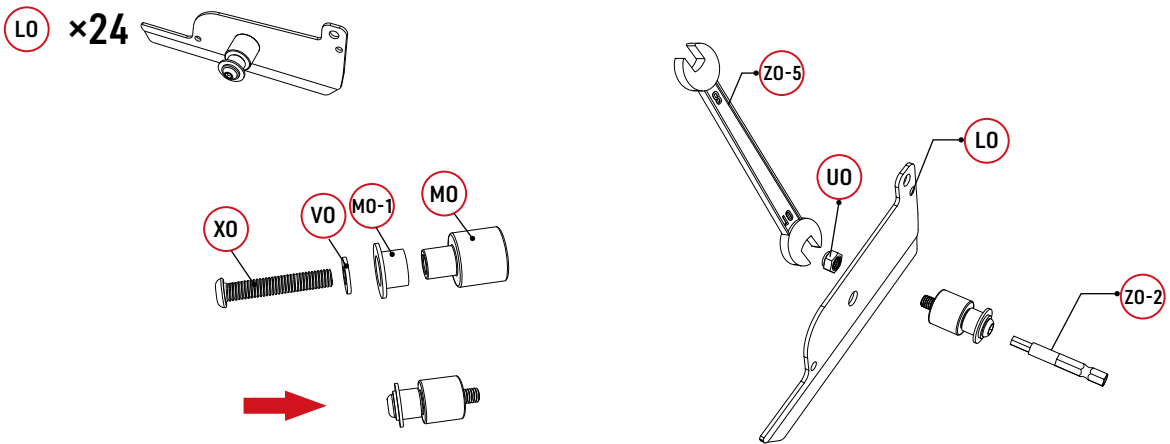

Install the spindles for the louver cover on both sides of the louvres.
 Note: To avoid any broken of the plastic parts(M0), when use the pistol drill, please reduce the twisting force of it .

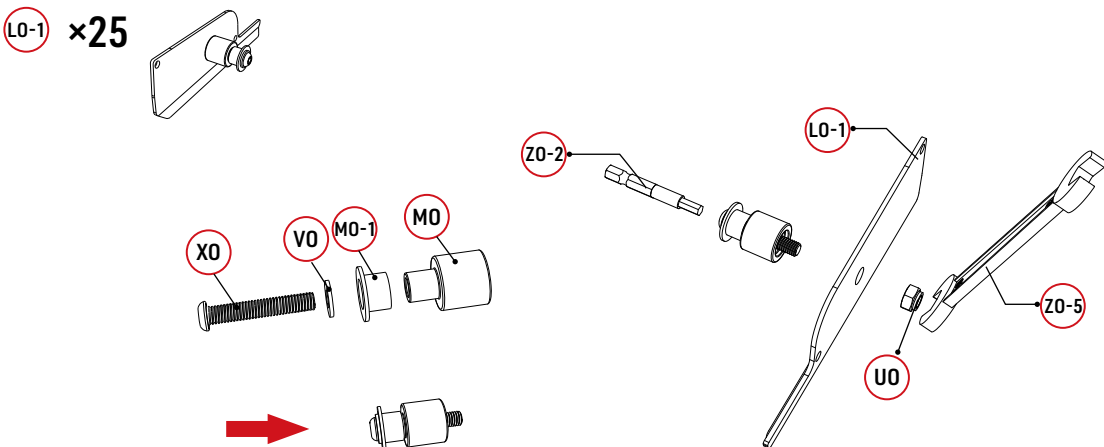





Louver sealing plate

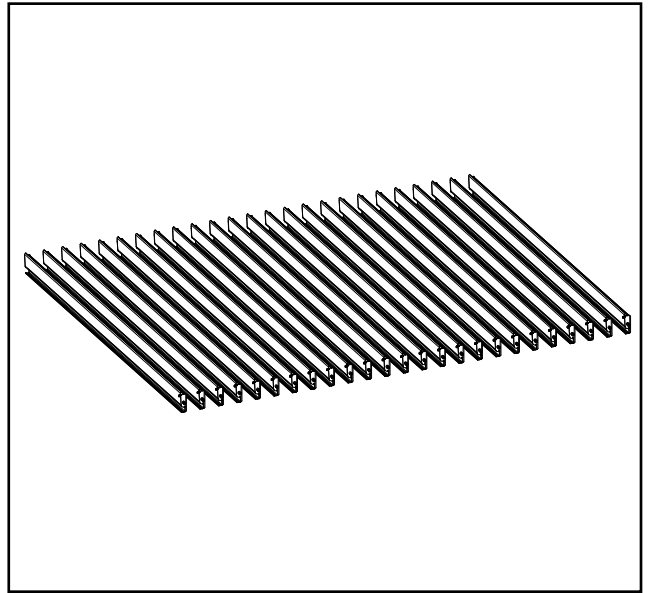

GO		25
----	--	----

KO		1
LO		24
LO-1		25
WO	 4x16  PH2	100



ZO-1	 4mm	1
ZO-2	 4mm	1
ZO-6	 PH2	1



Louver connection

Completion Diagram

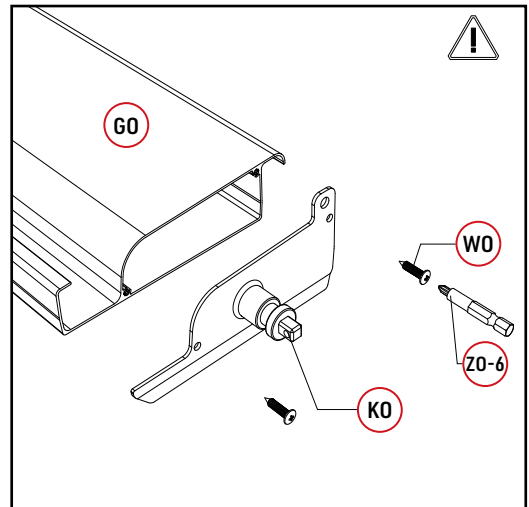
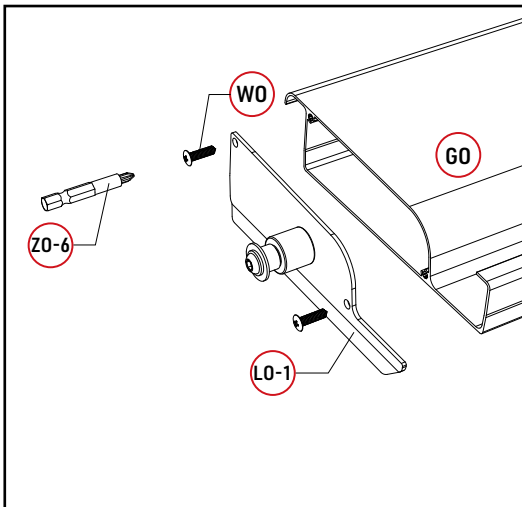
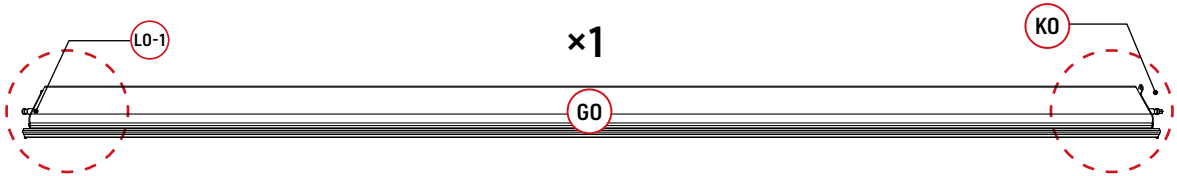

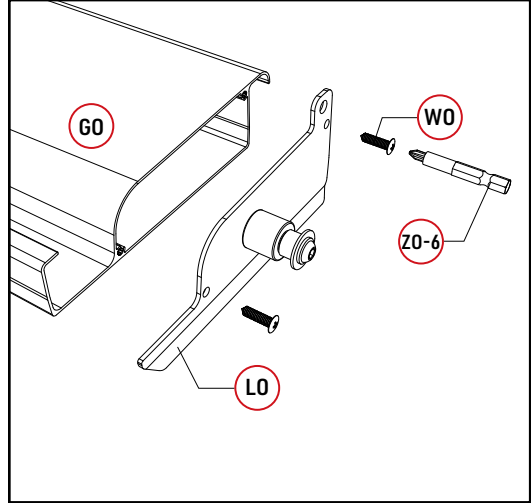
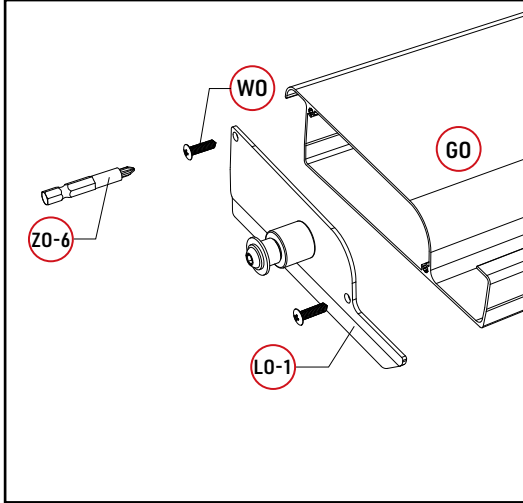
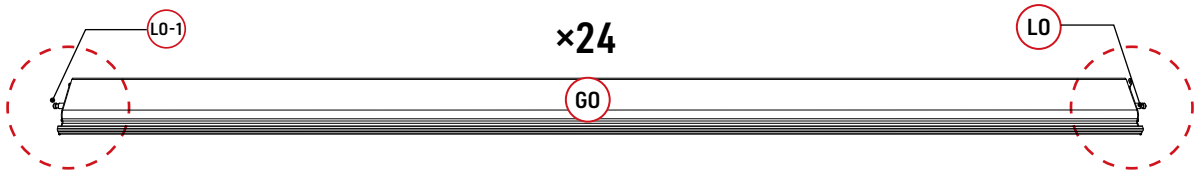

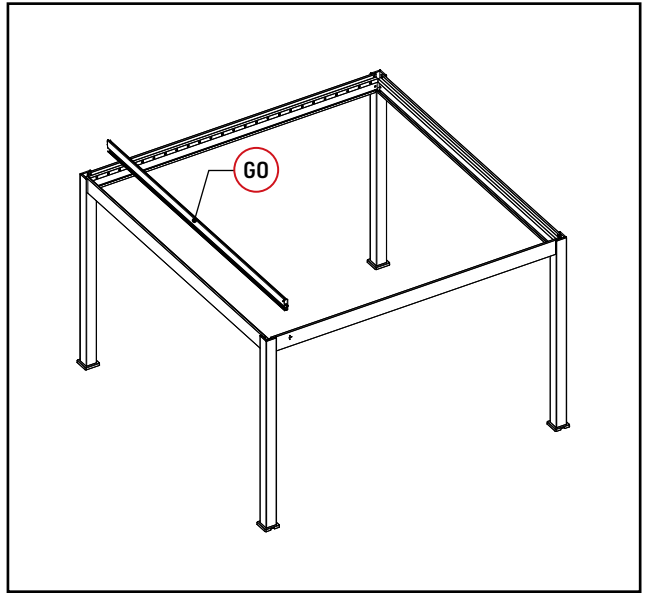

Fasten rubber plugs on both ends of the louvers

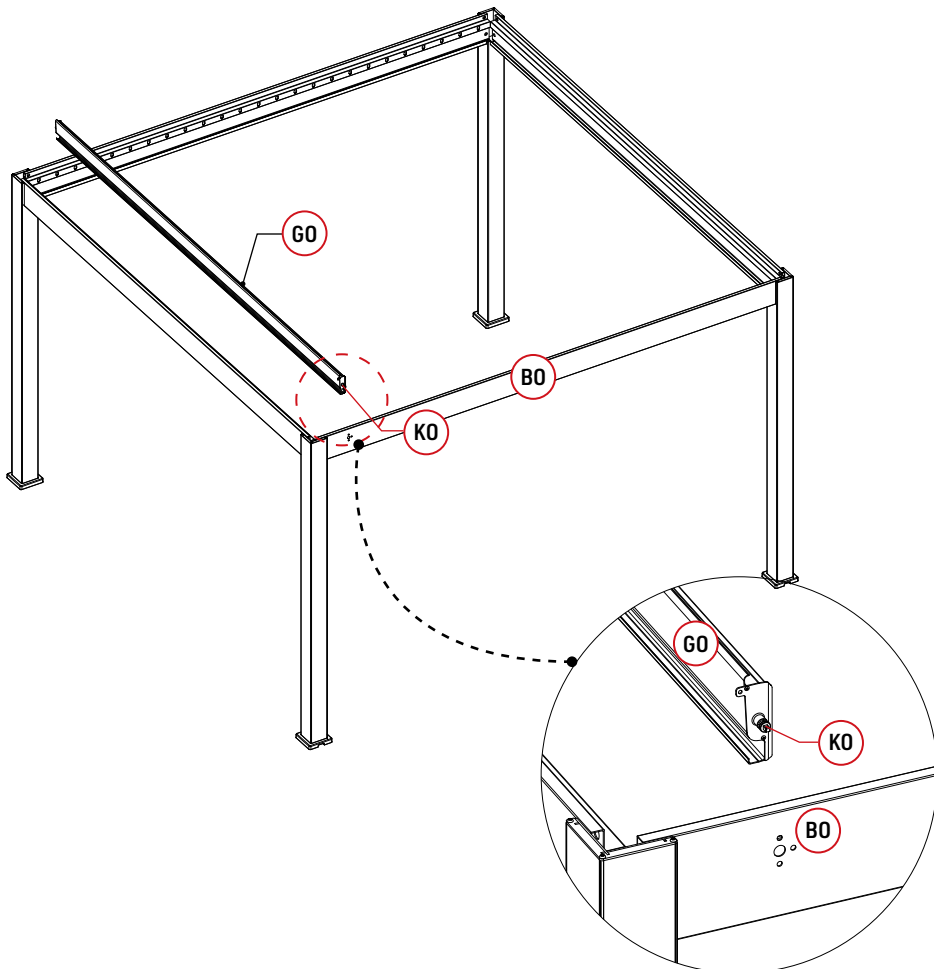

1

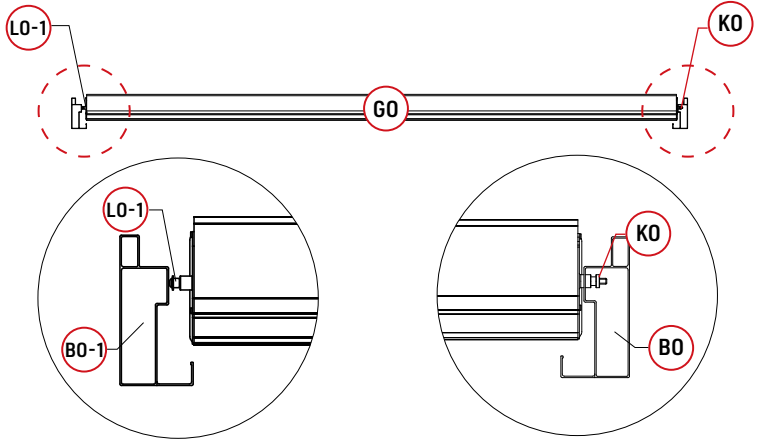
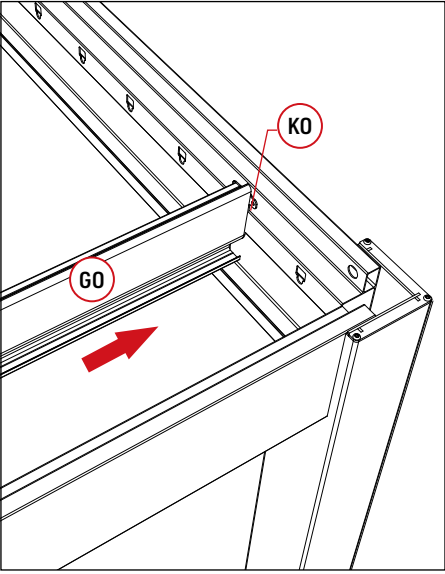

2

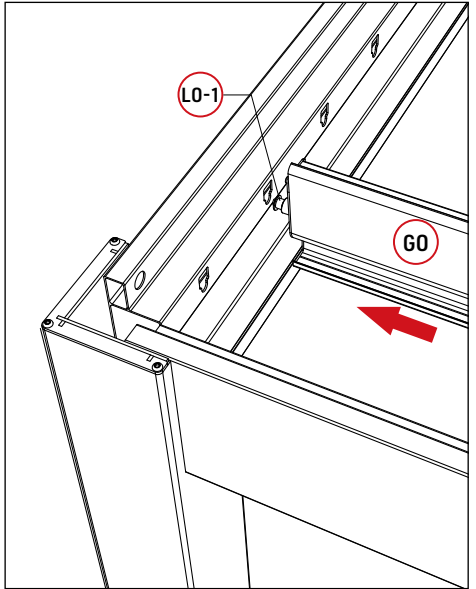
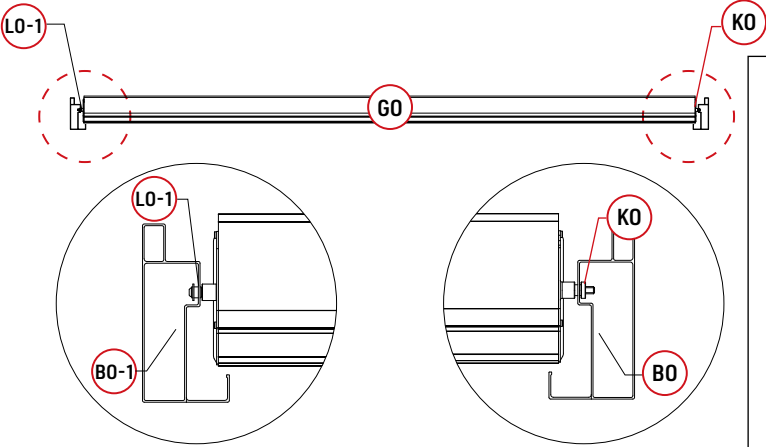

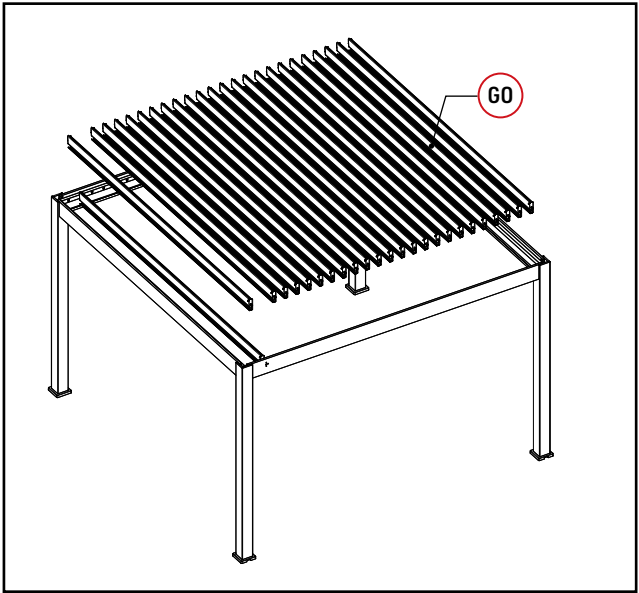





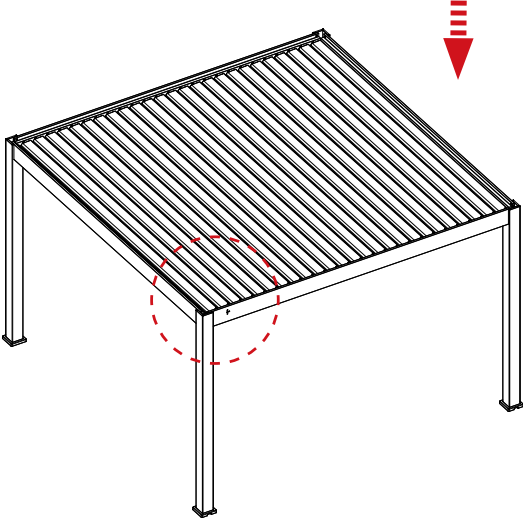

Put in the other louvers and seal the end caps

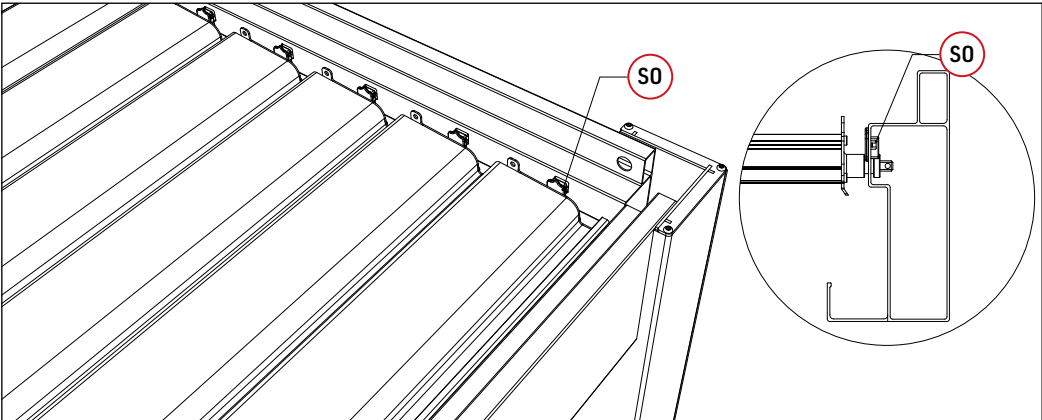
1





2

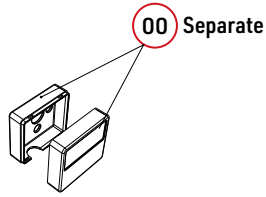
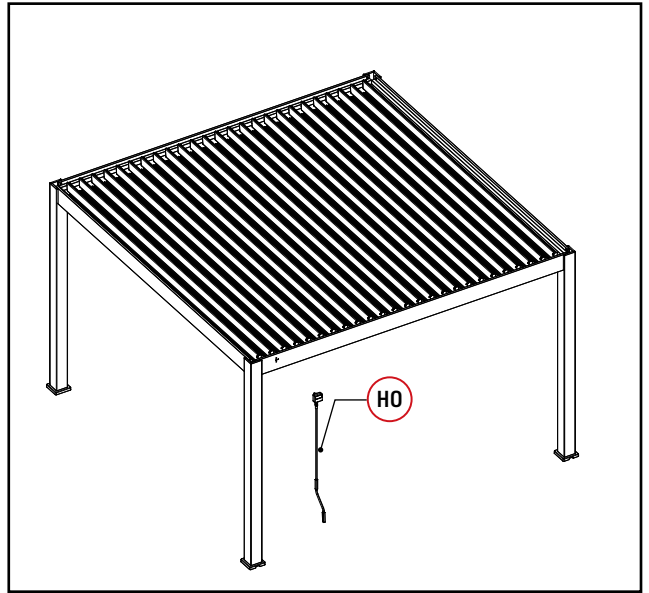

HO		1
NO		1
OO		1
PO		1
YO		3



ZO-1		1
ZO-2		1



Complete the connection of the main shaft louvers



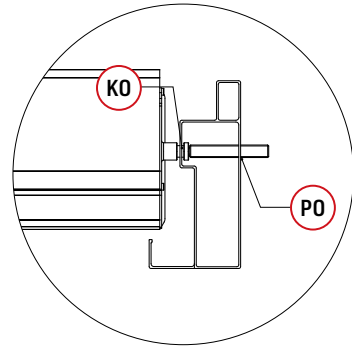
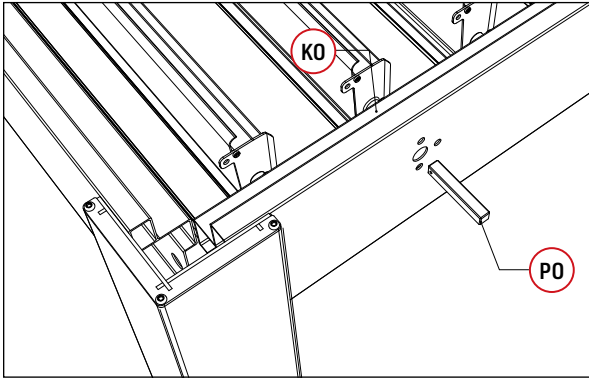

1

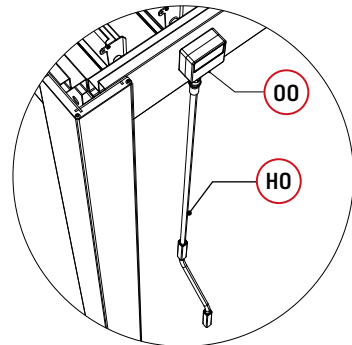
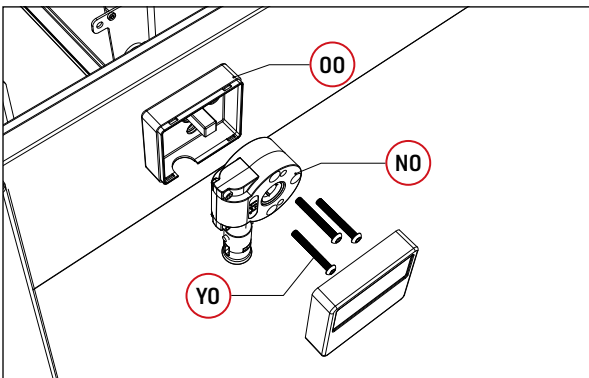





2

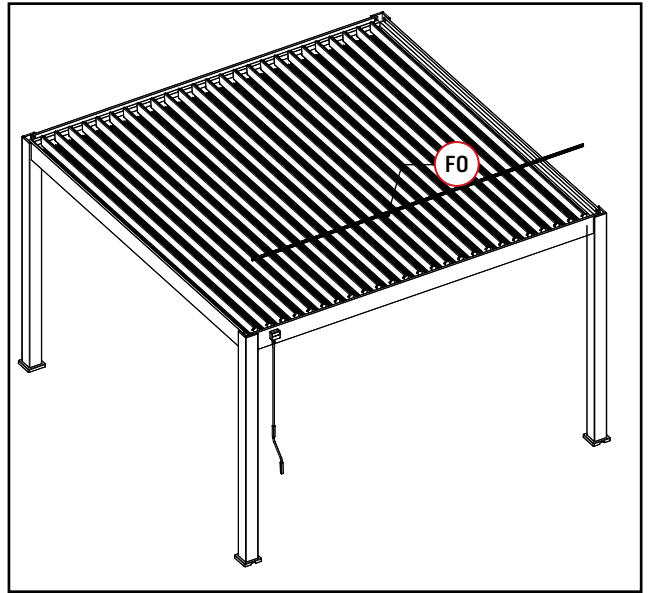

F0		1
----	--	---

X0-2		25
V0		75
U0		25
U0-1		25





Z0-1		1
Z0-2		1
Z0-5		1

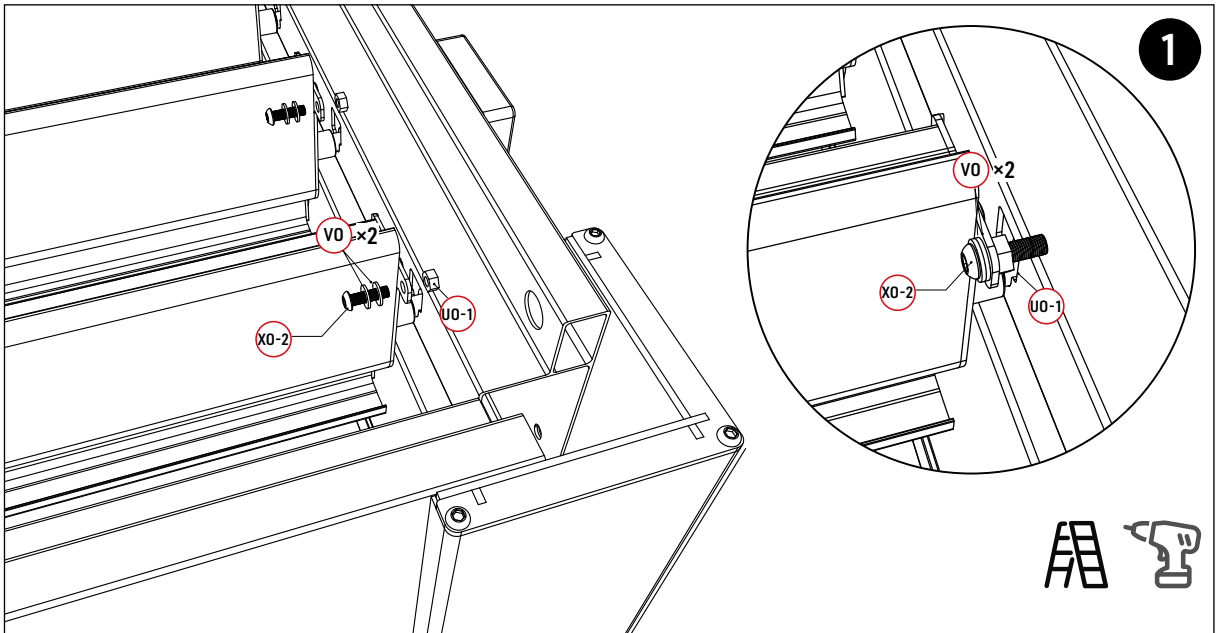

Louver connection

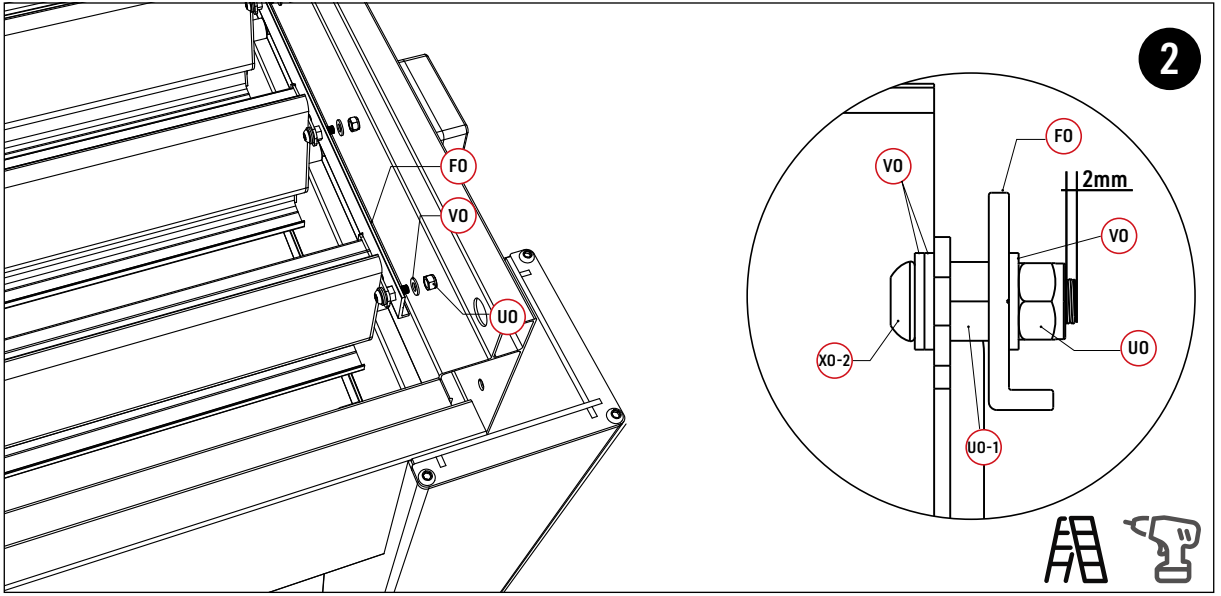



R0		16
T0	 10x80	16

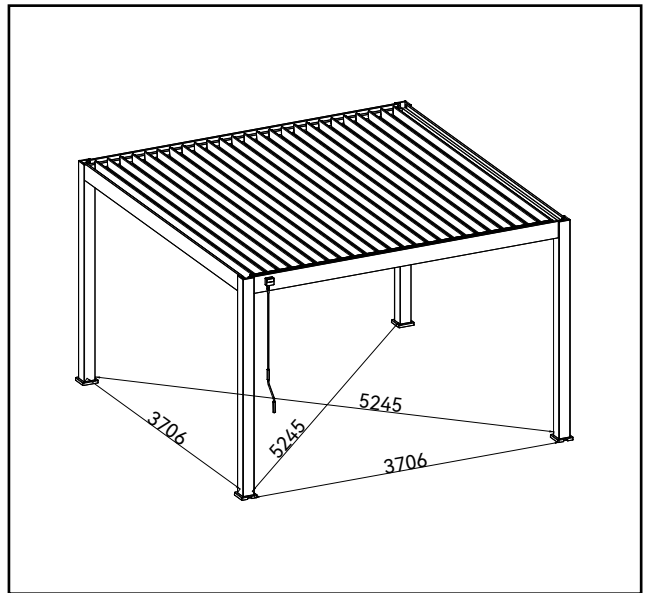

Close the cover to complete the fixing of the pergola

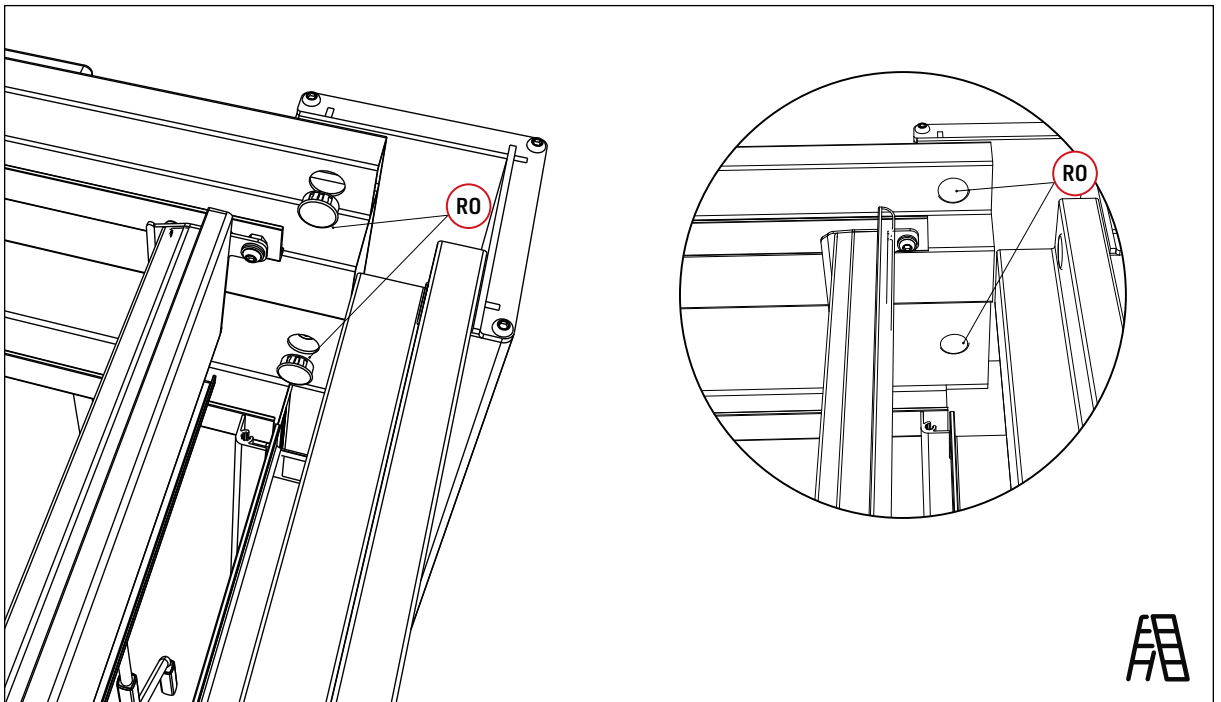

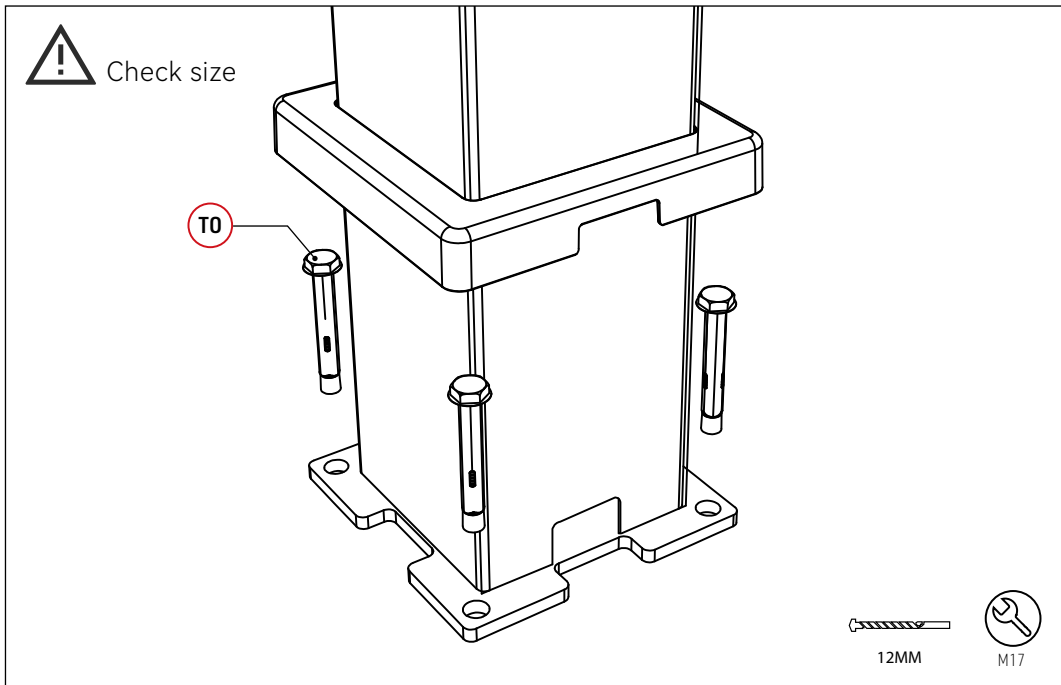

Move the bottom of the columns according to the dimensions on the front page to ensure that the dimensions are the same, then use a 12mm impact drill bit to guide the holes, then put in the expansion screws and tighten them with a M17 spanner.