

HEALTHCARE CATALOGUE

# DOMETIC HEALTHCARE

REFRIGERATORS AND SAFES  
FOR HEALTH AND CARE FACILITIES

 **DOMETIC** **PROFESSIONAL**





## **FOOD GRADE**

Convenient access to food items and beverages.



## **MEDICAL**

For safe storage of temperature-sensitive medicines.



## **SAFES**

Dometic ProSafe – Advanced technology for safe and secure storage of valuables

---

## **INTRODUCTION**

About Dometic

4 – 7

---

## **FOOD GRADE**

Dometic HiPro Care silent minifridges

10 – 11

Ventilation instructions

12 – 13

---

## **MEDICAL FRIDGES**

About Dometic Medical fridges

16

Dometic DS absorption refrigerators

17

Dometic HC compressor refrigerators

18 – 19

---

## **SAFES**

About Dometic ProSafe range

22 – 23

Dometic ProSafe Premium Class room safes

24 – 27

Dometic ProSafe Standard Class room safes

28 – 31

## **DOMETIC ON THE WEB**

Here's where you can find the complete Dometic range, with detailed information about all products. Plus, interesting facts about our company and download links for all our catalogues.

**DOMETIC.COM/PROFESSIONAL**





# ***THEIR HABITS THEIR WAY***

Keeping a bit of independence is about integrity and pride. It's about being able to have a glass of milk in the middle of the night if we want. To be able to decide for ourselves – it's one of life's small comforts when it means the most.

# WELL PROVEN FOR DECADES

## DOMETIC REFRIGERATORS AND SAFES FOR HEALTH AND CARE FACILITIES

Dometic is a leading manufacturer of cooling appliances for special applications – with decades of experience in the healthcare sector. Our reference list includes hospitals, retirement and nursing homes, doctor's surgeries, pharmacies and laboratories.

Dometic Food Grade refrigerators and Dometic Medical refrigerators have been proven thousands of times over, across Europe and beyond. They are not only among the most compact of their kind available in the market, but with the new HiPro Care line, also offer a completely silent food grade cooling solution. With its ProSafe range, Dometic also provides a reliable solution for secure storage of the patients' or residents' valuables.

All products for the healthcare sector are manufactured to stringent quality and environmental standards in Dometic's, certified factories. Our sales and service network spans almost 100 countries and provides personal support to customers and planners on all continents.

### RESPONSIBILITY FOR THE ENVIRONMENT

At Dometic, thinking and acting ecologically is an all-embracing process that extends to all levels – from the design of resource-saving, energy-efficient products to sustainable production processes and special recycling measures. You can be 100% sure that all applicable regulations, directives and guidelines are fulfilled.

### CERTIFIED QUALITY

- All Dometic Healthcare production plants are certified acc. ISO 9001 (quality management), ISO 14001 (environmental management) and ISO 50001 (energy management)
- All Dometic Healthcare products fulfill the European Union's product safety and environmental compliance requirements, i.e. Low voltage directive 2014/35 EU, EMC directive 2014/30/EU, RoHs directive 2011/65/EU and F-gas regulation No. 417/2014.



Dometic's certified production facility at Jászberény, Hungary



# DOMETIC PRODUCTS VALUE PROPOSAL

FOR HOSPITALS, RETIREMENT HOMES, SURGERIES AND PHARMACIES

## HOSPITALS & CLINICS

Having their own food grade Minifridge and ProSafe in the room gives patients peace of mind and comfort while away from home. They are less dependent on staff for drinks and food and can rest assured that their valuables are safely stored. This, in turn, relieves the staff and cuts on operating costs. Hotel-like amenities can also help hospitals and clinics stand out from their competitors. Medical refrigerators on the station floor provide easy access to daily medications and common prescriptions, which means shorter distances to go for the hospital staff.

**Product examples:** HiPro Care C60SFS, HC 302 DIN, DS 301 H and MD 363

## RETIREMENT HOMES

Dometic food grade Minifridge take up very little space and offer a great deal of comfort. With the introduction of the new HiPro Care line, residents and patients can not only maintain their independence by keeping their favorite food items close to them but also enjoy the serenity of the noiseless environment due to its silent operation. Designed to meet the unique needs of elderly homes and hospitals, it enhances the daily experience of residents and patients while

simultaneously minimizing operational costs for healthcare facilities. Dometic medical refrigerators provide safe storage for temperature-sensitive pharmaceuticals and fast access to “daily essentials”.

**Product examples:** HiPro Care A30SBI, HC 302 DIN and MD 363

## SURGERIES AND PHARMACIES

Dometic medical refrigerators keep temperature-sensitive pharmaceuticals, preparations and vaccines close at hand for immediate access. They provide safe storage at a temperature between +2°C and +8°C. The well organised, illuminated interior with practical drawers and compartments makes for easy handling.

**Product examples:** HC 302 DIN, HC 502 DIN and DS 601 H





# FOOD





# GRADE



# HIPRO CARE

SMALL. SILENT. STRONG.

Dometic HiPro Care minifridges seamlessly blend into the appearance of elderly homes and hospitals. Not only are they highly efficient, with remarkably low energy usage, but they also operate silently, contributing to a peaceful environment. The strong door rack maximizes storage space, improving the functionality of its elegant design. Furthermore, they stand out for their food-grade refrigeration capabilities, designed to accommodate a range of items—from delightful cakes to fresh milk and nutritious fruits—catering to the diverse dietary needs of patients and residents alike.

## DOMETIC HIPRO CARE. THE SILENT MINI FRIDGE.

Dometic HiPro Care food-grade absorption minifridges reach an interior temperature of 4°C at up to an ambient temperature of 32°C while being completely noiseless.

### IDEAL FOR:

- Resident rooms in Elderly homes
- Patient rooms in Hospitals



Built-in

Ideal for  
Patient In Room  
Comfort



Free-standing

To learn more, visit us under [dometic.com/hiprocare](https://dometic.com/hiprocare)



MODEL	HIPRO CARE A30S FS/BI	HIPRO CARE A40S FS/BI	HIPRO CARE C60S FS/BI
<b>Cooling technology</b>	Absorption	Absorption	Compressor
<b>Model class (litre)</b>	30	40	60
<b>Storage volume (litre)</b>	26	33	49
<b>Cabinet colour</b>	White	White	White
<b>Dimensions FS*</b> (H x W x D, in mm)	550 x 384 x 463	580 x 405 x 483	595 x 490 x 519
<b>Dimensions Built-in version**</b> (H x W x D, in mm)	520 x 384 x 446	550 x 405 x 466	565 x 490 x 510
<b>Can be built-in/integrated</b>	●	●	●
<b>Variable door hinge</b>	●	●	●
<b>LED interior light</b>	●	●	●
<b>Input rating (W)</b>	45	45	60
<b>Energy consumption</b> (kWh/24 h)	0.67 FS / 0.68 BI	0.67 FS / 0.68 BI	0.21 FS / 0.21 BI
<b>Noise level (db[A])</b>	0	0	36
<b>Features</b>	<ul style="list-style-type: none"> <li>Adjustable plastic shelf with recess for tall bottles</li> <li>Flat inner door surface for easy cleaning</li> </ul>	<ul style="list-style-type: none"> <li>2 adjustable plastic shelves with recess for tall bottles</li> <li>Flat inner door surface for easy cleaning</li> </ul>	<ul style="list-style-type: none"> <li>2 adjustable plastic shelves</li> <li>2 adjustable door racks</li> <li>Flat inner door surface for easy cleaning</li> </ul>
<b>Options</b>	<ul style="list-style-type: none"> <li>Sliding hinge</li> <li>Lock</li> </ul>	<ul style="list-style-type: none"> <li>Sliding hinge</li> <li>Lock</li> </ul>	<ul style="list-style-type: none"> <li>Sliding hinge</li> <li>Lock</li> </ul>

\*FS version: with foot frame, door decor panel and back cover, \*\* BI version: for fully-integrated installation (with sliding hinge)  
Please note our ventilation tips for built-in refrigerators (p. 12).



Food-Grade



Completely silent  
(Absorption models)



Spacious door storage



Control panel with led strip



Lockable door

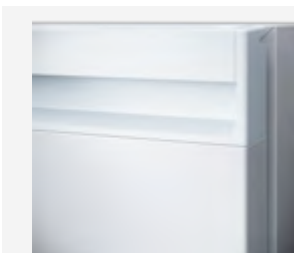

### EASY CUSTOMIZING WITH BUILT-IN MODELS

Designed for built-in use: BI minifridges are fitted in the factory with a sliding hinge to be fastened to the furniture door to compensate for the differing turning points between the furniture and fridge door. That means the refrigerators can be easily fitted with a front panel to suit your interior design concept.

# INSTALLATION TIPS FOR BUILT-IN REFRIGERATORS

Dometic absorption fridges are equipped with an electrically heated cooling unit which is virtually silent in operation. The heat which the cooling unit extracts from the refrigerator interior is emitted at the back of the fridge. If you have a free-standing model, sufficient ventilation is provided in most cases. If you want to integrate the fridge into a piece of furniture, however, the following instructions need to met.

Please note that there must be sufficient room for ventilation behind the refrigerator to prevent heat build-up. During installation, make sure that the refrigerator is standing on a stable, level surface, and not directly near a heat source. Ventilation must be provided as shown in the drawings below (A, B, C or D).

You can find all our documents, manuals and guidelines at [documents.dometic.com](http://documents.dometic.com).

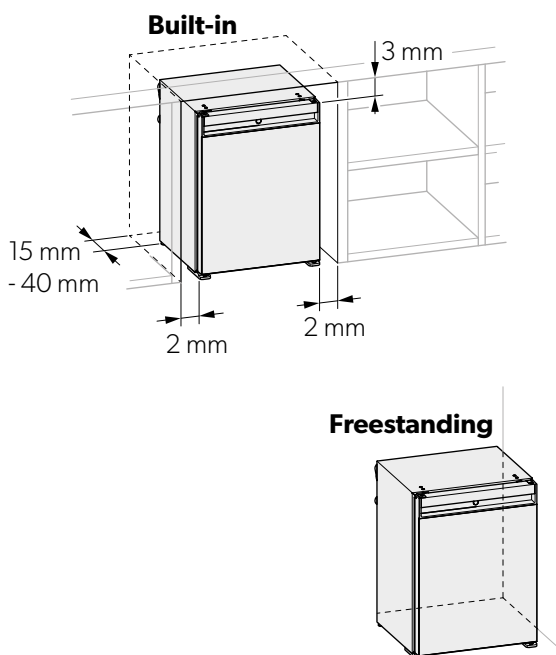
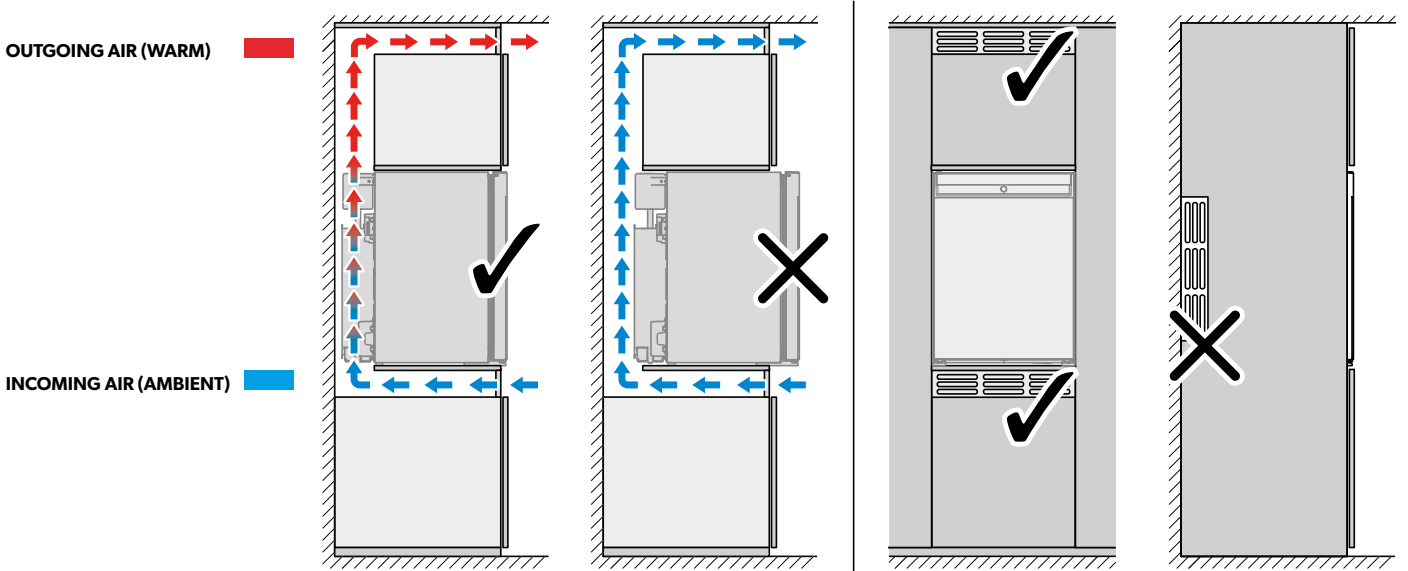

# VENTILATION GUIDELINES

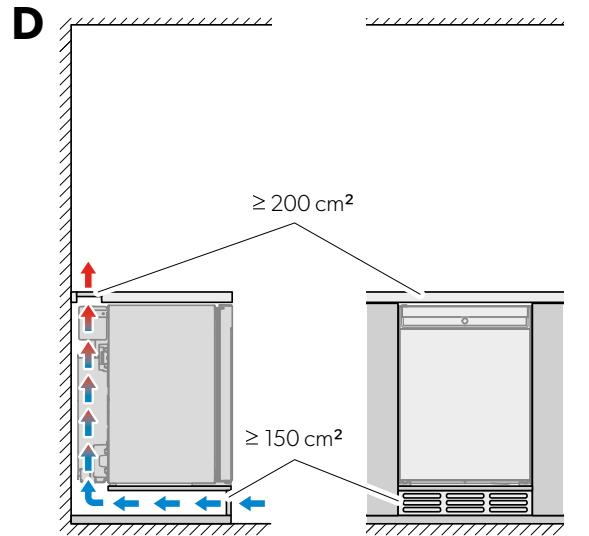
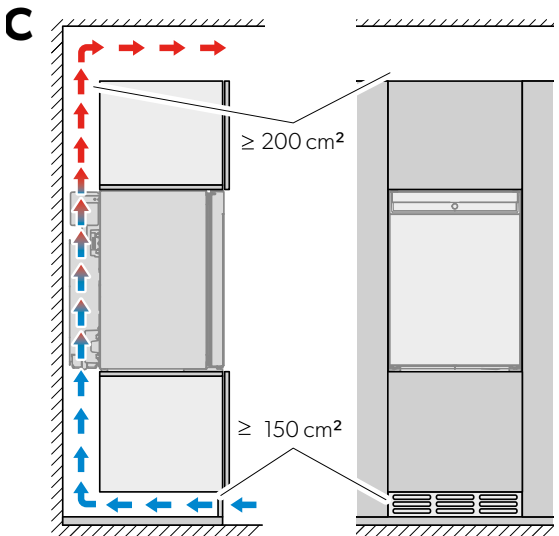
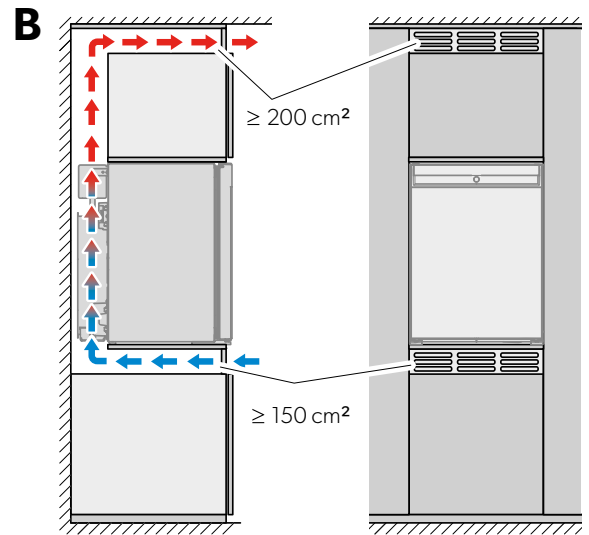
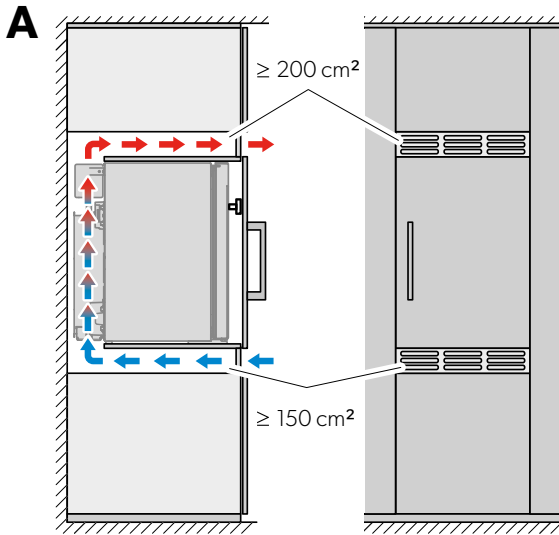

## Important note

Please read these instructions carefully and follow all instructions, guidelines, and warnings included in all our product manuals in order to ensure that you install, use, and maintain our products properly at all times.

By using our products, you hereby confirm that you have read all instructions, guidelines, and warnings carefully and that you understand and agree to abide by the terms and conditions as set forth herein. You agree to use our products only for the intended purpose and application and in accordance with the instructions, guidelines, and warnings as set forth in the product manuals as well as in accordance with all applicable laws and regulations. A failure to read and follow the instructions and warnings set forth herein may result in an injury to yourself and others, damage to your product or damage to other property in the vicinity. Our product manuals, including the instructions, guidelines, and warnings, and related documentation, may be subject to changes and updates. For up-to-date product information, please visit [dometic.com](http://dometic.com).

A woman with long dark hair, wearing a white lab coat, is shown in profile, looking down at a desk in a modern medical office. The office has large windows and glass partitions. The word "MEDICAL" is overlaid in large, bold, white capital letters across the center of the image.

# **MEDICAL**

# FRIDGES





# MEDICAL REFRIGERATORS

EXCELLENT STORAGE CONDITIONS FOR HIGHEST DEMANDS

The ideal solution for storing heat-sensitive medicine safely at a temperature between +2 °C and +8 °C. Practical drawers enable you to keep the medicine organised and structured. A digital thermometer monitors the internal temperature and stores the highest and lowest temperature for a defined control period.

You can choose between two series with different cooling technologies and quality features:

HC series with powerful, energy saving compressor technology: with integrated temperature display and high-quality, roller based metal drawers (3/4 extension) with plastic front

DS series with noiseless absorption cooling: for normal ambient temperatures, fitted with an external thermometer and plastic drawers with transparent front

## QUALITY FEATURES

- Constant cooling performance between +2 °C and +8 °C
- DIN certified medical refrigerators
- High-quality metal drawer with telescopic sliders
- Digital temperature display with memory function
- Audible alarm functions
- Lock included

## WHY CONVENTIONAL HOUSEHOLD REFRIGERATORS WON'T WORK

Conventional household refrigerators are unsuitable for the storage of insulin, vaccines, heparin products and other heat-sensitive pharmaceuticals. Here are the main reasons why:

- Unable to maintain the required temperature between +2 °C and +8 °C
- Temperature can rise to over +10 °C during defrosting phases
- Temperature data cannot be checked and documented
- Serious health risks for patients
- Liability risks for hospitals

**A medical refrigerator keeps you on the safe side.**



# DS SERIES MEDICAL REFRIGERATORS

## NOISELESS ABSORPTION COOLING

Well proven over the last decades, DS series medical refrigerators are ideal for safe storage of insulin and other heat-sensitive pharmaceuticals at a temperature between 2°C and 8°C. The drawers allow for an organised storage of pharmaceuticals. The external digital thermometer keeps the interior temperature under control.

- Noiseless absorption cooling unit
- Fuzzy Logic technology for low power consumption
- Factory fixed temperature setting
- LED interior light for user convenience
- Door lock for secure storage
- Drawers with flexible compartments for organized storage



Interior light



### TECHNICAL DATA

MODEL	DS 301 H	DS 601 H
<b>Storage volume</b> (litres)	26	49
<b>Cabinet colour</b>	White	White
<b>Cooling technology</b>	Absorption	Absorption
<b>Temperature</b> (fixed)	5 °C	5 °C
<b>Dimensions</b> (H×W×D, mm)	580×422×393	592×486×494
<b>Energy consumption</b> (kWh/24 h)	0.86	1.05
<b>Drawers</b> (number)	3	3
<b>Door lock</b>	•	•
<b>Digital thermometer with data memory</b>	External	External
<b>Variable door hinge</b>	•	•

# HC SERIES DIN MEDICAL REFRIGERATORS

## DIN VERSIONS

Medical refrigerators have to meet the very highest demands, and they have to be absolutely reliable. To be on the safe side, use equipment that complies with the DIN 58345 standard for pharmaceutical refrigerators, because it will meet the expectations for professional storage to the full extent. In addition to standard features like ventilated cooling and a safety lock, our DIN certified

equipment also provide a visual and audible warning function in case of temperature deviations. Thanks to an integrated battery the warning function (visual + audible) will even be maintained for at least 12 hours if the power supply fails. On top of that, DIN refrigerators are fitted with a potential free contact for alarm transmission.



Complies with DIN 13277 and Ö-Norm K2040



### TECHNICAL DATA

MODEL	HC 302 DIN	HC 502 DIN
<b>Cabinet colour</b>	White	White
<b>Cooling technology</b>	Compressor	Compressor
<b>Temperature (fixed)</b>	5°C	5°C
<b>Dimensions (H×W×D, mm)</b>	580×422×450	592×486×494
<b>Energy consumption (kWh/24 h)</b>	0.42	0.44
<b>Drawers (number)</b>	3	3
<b>Door lock</b>	Yes	Yes
<b>Digital thermometer with data memory</b>	Integrated	Integrated
<b>Variable door hinge</b>	No	No

- Complies with DIN 58345 and Ö-Norm K2040
- Keeps heat sensitive medicine between +2°C and +8°C
- Integrated fan for reliably constant temperature
- Features an audible warning system if the door is open for more than 20 s
- Compressor cooling technology
- Convenient, robust slide-out drawers

### ADDITIONAL DIN FEATURES

- Temperature variation alarm
- Power failure alarm
- External, potential free contact for alarm transmission
- AC powered display (no batteries)



Integrated in the door: illuminated thermometer min/max data memory to monitor the interior temperature



Drawers with transparent front panel



Ergonomic door handle



Interior light



Lockable door

# HC SERIES MEDICAL REFRIGERATORS

## NON DIN VERSIONS

Based on efficient compressor cooling, HC series medical refrigerators are amazingly powerful and energy-saving. Moreover, the models in the HC series are fitted with some useful extra features. High-quality, roller based metal drawers with 3/4 extension allow for convenient handling in everyday use, and the thermometer is integrated in the door.

- High-performance compressor cooling – even at high ambient temperatures
- Integrated in the door: illuminated thermometer min/max data memory to monitor the interior temperature
- High-quality, roller based metal drawers with 3/4 extension for well organised storage
- Door open alarm

Highly Efficient Compressor Cooling



### TECHNICAL DATA

MODEL	HC 302	HC 502
<b>Cabinet colour</b>	White	White
<b>Cooling technology</b>	Compressor	Compressor
<b>Temperature (fixed)</b>	5°C	5°C
<b>Dimensions (H×W×D, mm)</b>	580×422×450	592×486×494
<b>Energy consumption (kWh/24 h)</b>	0.42	0.44
<b>Drawers (number)</b>	3	3
<b>Door lock</b>	Yes	Yes
<b>Digital thermometer with data memory</b>	Integrated	Integrated
<b>Variable door hinge</b>	No	No



Integrated thermometer



Drawers with transparent front panel



Ergonomic door handle



Interior light



Lockable door



# SAFETY &





# **FROM STANDARD TO PREMIUM**

## **The range of Dometic ProSafe models**

Security is an essential requirement for patients, and can be one of the of the main reasons for choosing or discarding a care facility. The Dometic Group aware of this, is always developing and improving all of its products in order to meet the needs of customers.

The latest product innovation Dometic has launched is a proSafe range which goes one step further in terms of design, functionality, technology and security. This proSafe range has a very modern design with a color display, an illuminated keypad, the latest anti-tampering system and a new website platform which offers the possibility to

operate the safe with the strictest security. The elegant cabinets of the new proSafe generation have rounded corners and edges for enhanced safety.

- Master key
- LED interior light
- iAudit system – unique in the industry
- Remote Emergency Opening System (REOS 2.0)  
– ultimate security and user comfort
- Battery level check



**Premium Class**

Excellence in form and function: Dometic innovations like iAudit tracking and the REOS Remote Emergency Opening System ensure security on all levels.

**Standard Class**

High security level combined with easy operation for perfect comfort and convenience.

**PRODUCT FINDER – THE QUICK WAY TO FIND THE RIGHT PRODUCT**

**Laser-cut door**

Our doors are precisely cut and crafted by a laser beam. This allows us to achieve 100% accuracy in dimensions and an extremely small clearance between the door and casing, making the door impossible to pry open.

**Anti-Tamper system**

With the anti-tampering system, Dometic offers a unique security feature for their models. All anti-tampering manipulation attempts are recorded in the electronic of the safe and can be tracked back at any time.

**REOS code**

REOS stands for Dometic’s Remote Emergency Opening System. The emergency-opening system from Dometic is based on an innovative encoding system. The unique solution combines advanced electronics with state-of-the-art online technology to allow simple yet highly secure emergency opening by authorised facility staff.

**Premium iAudit**

All operations effected on a safe must be documented – for your own security and for your insurance provider. This is where

Dometic’s Premium iAudit system offers a truly convenient solution: the integrated microchip provides storage capacity for the last 1,000 events.

**SAM**

The unique Dometic safe management system (SAM) allows for iAudit Trail and one time emergency code generation (REOS) from a user friendly but PIN secured internet based software tool.

● Yes / – No / ○ Optional

WHAT’S IMPORTANT TO YOU?	PREMIUM CLASS	STANDARD CLASS
Easy operation	●	●
Motorised opening	●	●
LED interior light	●	●
LED display	●	●
Emergency opening with master key	●	●
Emergency opening with master code	●	●
Emergency opening with REOS Code	○	–
Anti-Tamper System	○	–
Premium iAudit	●	–
SAM	○	–
Laser-cut door	●	–
From page	34	38

# ***PREMIUM CLASS IN-ROOM SAFES***

**SAFE TO SAY IT'S MORE CONVENIENT**





# DOMETIC PREMIUM CLASS SAFES

Protection for more privacy – comfortably and with absolute reliability. With a Dometic Premium Class proSafe, the room becomes a perfectly private haven for the resident. A safe place for storage, conceived and implemented according to the newest standards. Its innovative and customisable design suits every hotel in a stylish way. Smooth surfaces and rounded edges make it easy to look after and give it long-lasting character. A color display and the integrated soft-touch keypad make operation easy. And a Premium Class proSafe also

breaks new ground when it comes to protective properties: pioneering technology like the unique iAudit and the anti-tampering system ensure security on all levels. The demand for contemporary security systems with added convenience is supported by special features such as REOS 2.0 software with its emergency code-opening system (optional).



- LED interior light
- Laser-cut door and frame
- iAudit for convenient documentation
- Emergency opening with key and master code
- Remote Emergency Opening System (REOS 2.0) – ultimate security and user comfort (optional)

## WIDE CHOICE OF MODELS AND SIZES

Dometic ProSafe MD series Premium Class safes are available in various sizes to suit different capacity demands, interior designs and installation conditions. Sizes range from 8.2 to 29 litres.



### Batteries included

Dometic safes come ready to use.



### Plug

Optional inside plug to charge mobile devices.

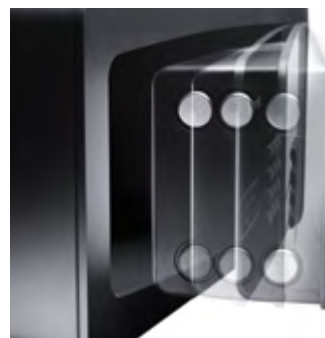

### Automatic opening

Safe door opens automatically.



### Fixing kit

Optional fixing kit for secure fastening.

**SAFETY & SECURITY**

**SAFETY SOLUTIONS / PROSAFE PREMIUM CLASS**

TECHNICAL DATA			
MODEL	MD 283	MD 363	MD 383
<b>Type of product</b>	Electronic safe		
<b>Capacity (litres)</b>	8.2	24	28
<b>Exterior dimensions (H×W×D, mm)</b>	165 × 280 × 235	190 × 360 × 410	190 × 380 × 450
<b>Interior dimensions (H×W×D, mm)</b>	162 × 277 × 185	187 × 357 × 360	187 × 377 × 400
<b>Steel thickness (mm)</b>	Door: 5.0 / Body 1.2	Door: 5.0 / Body 1.5	Door: 5.0 / Body 1.5
<b>Net weight (kg)</b>	6.1	10.2	11.3
<b>Keypad</b>	ADA-compliant rubber keypad		
<b>Display</b>	White LED color display, 4-digit guest code, English language		
<b>Locking mechanism</b>	Two 18 mm solid steel bolts		
<b>Locking system</b>	Motorised with automatic opening		
<b>Power</b>	4 LR6/AA 1.5 V batteries (incl.)		
<b>Cabinet color</b>	Anthracite		
<b>FEATURES</b>			
<b>LED interior light</b>	●	●	●
<b>Laser cut technology</b>	●	●	●
<b>Masterkey opening*</b>	●	●	●
<b>Mastercode opening</b>	●	●	●
<b>Anti-tampering System</b>	○	○	○
<b>REOS</b>	○	○	○
<b>iAudit</b>	●	●	●
<b>Laptop size</b>	–	15"	17"
<b>OPTIONS</b>			
	<ul style="list-style-type: none"> <li>• Left-hand hinge</li> <li>• Fixing Kit</li> <li>• Master key</li> </ul>	<ul style="list-style-type: none"> <li>• Left-hand hinge</li> <li>• Two steps emergency code opening (REOS)</li> <li>• Fixing Kit</li> <li>• Master key</li> </ul>	<ul style="list-style-type: none"> <li>• Left-hand hinge</li> <li>• Two steps emergency code opening (REOS)</li> <li>• Fixing Kit</li> <li>• Master key</li> </ul>

\*Master keys are optional, must be ordered separately, and are model-specific.



TECHNICAL DATA

MODEL	MD 408	MD 493	MDD 403	MDT 403
<b>Type of product</b>	Electronic safe			
<b>Capacity</b> (litres)	22.5	29	15.7	9.7
<b>Exterior dimensions</b> (H x W x D, mm)	190 x 405 x 350	190 x 490 x 370	200 x 400 x 400	125 x 400 x 350
<b>Interior dimensions</b> (H x W x D, mm)	187 x 402 x 300	187 x 487 x 320	135 x 315 x 370	75 x 380 x 300
<b>Steel thickness</b> (mm)	Door: 5.0 / Body 1.5	Door: 5.0 / Body 1.5	Door: 5.0 / Body 1.5	Door: 5.0 / Body 1.5
<b>Net weight</b> (kg)	10.4	12.4	17.5	13.7
<b>Keypad</b>	ADA-compliant rubber keypad			
<b>Display</b>	White LED color display, 4-digit guest code, English language			
<b>Locking mechanism</b>	Two 18 mm solid steel bolts			
<b>Locking system</b>	Motorised with automatic opening			
<b>Power</b>	4 LR6/AA 1.5 V batteries (incl.)			
<b>Cabinet color</b>	Anthracite			
<b>FEATURES</b>				
<b>LED interior light</b>	●	●	●	●
<b>Laser cut technology</b>	●	●	●	●
<b>Masterkey opening*</b>	●	●	●	●
<b>Mastercode opening</b>	●	●	●	●
<b>ANTI-TAMPERING SYSTEM</b>	○	○	○	○
<b>REOS</b>	○	○	○	○
<b>iAudit</b>	●	●	●	●
<b>Laptop size</b>	15"	17"	15"	15"
<b>OPTIONS</b>				
	<ul style="list-style-type: none"> <li>• Left-hand hinge</li> <li>• Two steps emergency code opening (REOS)</li> <li>• Fixing Kit</li> <li>• Master key</li> </ul>	<ul style="list-style-type: none"> <li>• Left-hand hinge</li> <li>• Fixing Kit</li> <li>• Master key</li> </ul>	<ul style="list-style-type: none"> <li>• Two steps emergency code opening (REOS)</li> <li>• Fixing Kit</li> <li>• Master key</li> </ul>	<ul style="list-style-type: none"> <li>• Two steps emergency code opening (REOS)</li> <li>• Fixing Kit</li> <li>• Master key</li> </ul>

\*Master keys are optional, must be ordered separately, and are model-specific.

● Yes / – No / ○ Optional

# DOMETIC STANDARD CLASS SAFES

**Robustly made with user-friendly features and functions**

It puts residents' mind at rest to have a safe place for their valuables. Providing a secure space for important or valuable objects is a distinctive feature when choosing a hotel room or suite. With a Standard Class proSafe, you can create a reliable spot in the room that is worth every penny. Security and functionality are paramount with all Dometic safe models. The Standard Class safe models offer your residents a high level of security thanks to their robust construction. Their simple and intuitive usability provides perfect comfort and convenience.

- Robust and reliable
- LED display
- LED interior light
- Master key and master code emergency opening
- Wide choice: vertical, horizontal, top-opening

## DOMETIC PROSAFE MDL – VERTICAL OR HORIZONTAL

MDL 408



MDL 193

With quality and security at their core, these value-for-money in-room safes significantly enhance the security of existing rooms.

- Value-for-money solution
- Vertical or horizontal model – both with 18.4 litres capacity
- Easy installation inside a cabinet or on the wall
- Emergency opening with master code or master key
- Battery-low warning alerts users to change battery

# DOMETIC PROSAFE MD 310 / 390 / 450 SAFE INVESTMENT

The doors on all the Standard Class safe models are precisely cut and crafted. Their robust construction and a locking system with extra-strong steel bolts leave no point of attack for burglars. The LED interior light minimises the risk of forgotten valuables. Fast and secure emergency opening is possible with a master key or master code (depending on the model).

- Robust, reliable construction for optimal safety
- LED interior light makes the contents visible at a glance
- Emergency opening with master key or master code



# DOMETIC PROSAFE MDT TOP-OPENING SAFE

Part of the Dometic Standard Class range, the Dometic proSafe MDT 400 X top-opening safe provides a simple, yet ingenious solution that is easy to operate and safe to use. The top-opening drawer safe can be integrated in an existing furniture drawer and provides easy access to guests' valuables. At the same time it meets the highest demands on ergonomic design, comfort and security with an LED inside light for standard, master key and master code opening possibility in case of emergency, digital LED illuminated keypad, four-digit code and top-opening stabilizer arm. An audio signal confirms that the safe is securely locked.

- Convenient access from above
- LED interior light makes the contents visible at a glance
- Enough room to fit laptop and tablet computers
- Ideal for installation into existing hotel room drawer
- Stabilizer arm for smooth opening and closing of the lid



### Easy operation

The operation is easy to understand and explained via the pictogram.

### Handle

Integrated handle for easy opening and closing.

### Light the way

Standard LED interior lighting.

### Soft close

Muted door closing.

**SAFETY & SECURITY**

**SAFETY SOLUTIONS / PROSAFE STANDARD CLASS**



MODEL	MD 310	MD 390	MD 450
<b>TECHNICAL DATA</b>			
<b>Type of product</b>	Electronic safe		
<b>Capacity</b> (litres)	9	31.5	30.4
<b>Exterior dimensions</b> (H × W × D, mm)	165 × 310 × 245	200 × 390 × 480	200 × 450 × 400
<b>Interior dimensions</b> (H × W × D, mm)	161 × 306 × 182	196 × 386 × 418	196 × 446 × 348
<b>Steel thickness</b> (mm)	Door: 5.0 / Body 2	Door: 5.0 / Body 2	Door: 5.0 / Body 2
<b>Net weight</b> (kg)	7.1	14.3	14.5
<b>Keypad</b>	Rubber keypad		
<b>Display</b>	Red LED 4-digit guest code, English language		
<b>Locking mechanism</b>	Two 19 mm steel bolts		
<b>Locking system</b>	Motorised with automatic opening		
<b>Power</b>	4 LR6/AA 1.5 V batteries (incl.)		
<b>Cabinet color</b>	Anthracite		
<b>FEATURES</b>			
<b>Confirmation buzzer</b>	●	●	●
<b>LED interior light</b>	●	●	●
<b>Door handle opening</b>	-	-	-
<b>Masterkey opening*</b>	●	●	●
<b>Mastercode opening</b>	●	●	●
<b>Anti-tampering System</b>	-	-	-
<b>REOS</b>	-	-	-
<b>iAudit</b>	-	-	-
<b>Laptop size</b>	-	17"	15"
<b>OPTIONS</b>			
<b>(available for all models)</b>	<ul style="list-style-type: none"> <li>• Left-hand hinge</li> <li>• Fixing kit</li> <li>• Master key</li> </ul>		

\*Master keys are optional, must be ordered separately, and are model-specific.



**MDT 400X**

**MDL 408**

**MDL 193**

		Electronic safe	
9.7	18.4	18.4	
130 x 400 x 350	190 x 405 x 300	405 x 190 x 300	
75 x 380 x 300	187 x 402 x 245	402 x 187 x 245	
Door: 3.0 / Body 1.5	Door: 4.0 / Body 1.5		
9	10		
Rubber keypad	Rubber keypad		
Red LED 4-digit guest code, English language	Red LED 4-digit guest code, English language		
Two 19 mm steel bolts	Two 18 mm solid steel bolts		
Motorised with automatic opening	Motorised		
4 LR6/AA 1.5 V batteries (incl.)	4 LR6/AA 1.5 V batteries (incl.)		
Anthracite	Anthracite		
●	–		–
●	–		–
–	●		●
●	●		●
●	●		●
–	–		–
–	○		○
–	○		○
15"	13"		13"
<ul style="list-style-type: none"> <li>• Fixing kit</li> <li>• Master key</li> </ul>	<ul style="list-style-type: none"> <li>• Left-hand hinge</li> <li>• Fixing kit</li> <li>• White cabinet color</li> <li>• Master key</li> </ul>	<ul style="list-style-type: none"> <li>• Left-hand hinge</li> <li>• Fixing kit</li> <li>• White cabinet color</li> <li>• Master key</li> </ul>	

● Yes / – No / ○ Optional



Dometic is a leading manufacturer of compact refrigeration for special applications – with decades of experience in the healthcare sector. We offer tailor-made solutions to keep patients comfortable and safe with a wide range of cooling options to store medicines, refreshments and safe lockers to protect personal belongings. Our customers include hospitals as well as clinics, retirement and nursing homes.







**BELGIUM, NETHERLANDS  
& LUXEMBOURG**

**Domestic BeNeLuX**

Lourdesstraat 84 B  
B-8940 Geluwe

Tel +32 2 3598040  
+32 (0) 478 6414 68

Mail [hospitality\\_nl@dometic.com](mailto:hospitality_nl@dometic.com)

**DENMARK**

**Domestic Denmark A/S**

Nordensvej 15, Taulov  
DK-7000 Fredericia

Tel +45 75585966

Mail [hospitality\\_ne@dometic.com](mailto:hospitality_ne@dometic.com)

**FINLAND**

**Domestic Finland Oy**

Valimotie 15

FIN-00380 Helsinki

Tel +358 20 7413220

Mail [hospitality\\_ne@dometic.com](mailto:hospitality_ne@dometic.com)

**FRANCE**

**Domestic SAS**

6 Avenue du Poteau  
Batiment B1

60300 Chamant

Tel +33 3 44633521/33

Mail [hospitality\\_fr@dometic.com](mailto:hospitality_fr@dometic.com)

**GERMANY, AUSTRIA  
& SWITZERLAND**

**Domestic GmbH**

In der Steinwiese 16  
D-57074 Siegen

Tel +49 (0) 271 692 134 / 142  
+49 (0) 271 692 127

Mail [hospitality\\_de@dometic.com](mailto:hospitality_de@dometic.com)

**ITALY**

**Domestic Italy S.r.l.**

Via Virgilio, 3

I-47122 Forlì (FC)

Tel +39 0543 754901

Mail [hospitality\\_it@dometic.com](mailto:hospitality_it@dometic.com)

**MIDDLE EAST & AFRICA**

**Domestic Middle East FZCO**

P.O. Box 17860

S-D 6, Jebel Ali Freezone

Dubai

Tel +971 4 883 3858

Mail [hospitality\\_ae@dometic.com](mailto:hospitality_ae@dometic.com)

**NORWAY**

**Domestic Norway AS**

Elveveien 30B

3262 Larvik

Tel +47 33428450

Mail [hospitality\\_ne@dometic.com](mailto:hospitality_ne@dometic.com)

**SWEDEN**

**Domestic Scandinavia AB**

Gustaf Melins gata 7

S-421 31 Västra Frölunda

Tel +46 31 7341100

Mail [hospitality\\_ne@dometic.com](mailto:hospitality_ne@dometic.com)

**SPAIN**

**Domestic Spain, S.L.**

Avda. Sierra del Guadarrama, 16

E-28691 Villanueva de la Cañada

Madrid

Tel +34 91 833 6089

Mail [hospitality\\_es@dometic.com](mailto:hospitality_es@dometic.com)

**PORTUGAL**

**Domestic Spain, S.L.**

Branch Office em Portugal

Rot. de São Gonçalo nº 1– Esc. 12

2775-399 Carcavelos

Tel +351 219 244 173

Mail [hospitality\\_pt@dometic.com](mailto:hospitality_pt@dometic.com)

**UNITED KINGDOM & IRELAND**

**Domestic UK Ltd.**

Domestic House, The Brewery,

Blandford St. Mary's

Dorset DT11 9LS

Tel +44 125 841 4581

Mail [hospitality\\_uk@dometic.com](mailto:hospitality_uk@dometic.com)

We distribute our products in around 100 markets. Please mail us at: [hospitality@dometic.com](mailto:hospitality@dometic.com), or check our website [dometic.com/healthcare](http://dometic.com/healthcare)

**USA & CANADA**

**Domestic Corporation**

Columbia Centre 1

5600 N. River Rd

Suite 250

Rosemont, IL 60018

Tel +1 574 326 7635

Tel +1 574 294 2511

Mail [hospitality\\_us@dometic.com](mailto:hospitality_us@dometic.com)

**MEXICO**

**Domestic MX**

Circuito Médicos No. 6 Local 1

Colonia Ciudad Satélite

CP 53100 Naucalpan de Juárez

Estado de México

Tel +52 55 5374 4108

Mail [hospitality\\_mx@dometic.com](mailto:hospitality_mx@dometic.com)

**EXPORT**

**Domestic Competence Center**

Circuito Médicos No. 6 Local 1

Colonia Ciudad Satélite

CP 53100 Naucalpan de Juárez

Estado de México

Tel +52 55 5374 4108

Mail [hospitality\\_mx@dometic.com](mailto:hospitality_mx@dometic.com)

**AUSTRALIA**

**Domestic Austria**

7 Nursery ave

Clayton South

Victoria 3169

Tel +61 1800 212 121

Mail [hospitality\\_au@dometic.com](mailto:hospitality_au@dometic.com)

**CHINA**

**Domestic Asia Co., Ltd**

Room 803-805A, Waterfront Place Block E,

No.31, Lane 168, Daduhe Road, Putuo

District, Shanghai, China

Tel +86-21-60325088

Mail [hospitality\\_cn@dometic.com](mailto:hospitality_cn@dometic.com)

**JAPAN**

**Domestic KK**

Maekawa-Shibaura, Bldg. 2

2-13-9 Shibaura Minato-ku

Tokyo 108-0023

Tel +81 3 5445 3333

Mail [hospitality\\_jp@dometic.com](mailto:hospitality_jp@dometic.com)