



# COMMERCIAL HEATING, VENTILATION AND AIR CONDITIONING SOLUTIONS

## CATALOGUE 2024



**EUROPE**

# INDEX

SERIES	PAGE	SERIES	PAGE	SERIES	PAGE
<b>09</b>		30WI	339	42SI	835
09PE	479	30XBE / 30XBP	259	42WM	845
09VE	485	30XBE-ZE / 30XBP-ZE	231		
		<b>NEW</b> 30XF	291	<b>50</b>	
<b>10</b>		30XW / 30XWP	375	50CJ	1023
10TE	489	30XWH / 30XWHP	715	50CO	1033
		30XWHV	703	<b>NEW</b> 50FF-FC 020-093	1039
<b>16</b>		30XWHVZE	691	50FF-FC 100-280	1065
16LJ-F	439	30XWHPZE	677	<b>NEW</b> 50NC	1089
16NK	475	30XWP-ZE	349		
16TJ	429	30XW-V	403	<b>61</b>	
		30XW-VZE	363	61AF 030-105	521
				<b>NEW</b> 61CG	533
<b>19</b>		<b>36</b>		<b>NEW</b> 61CA	743
19DV	415	<b>NEW</b> 36XH	783	<b>NEW</b> 61CWD	751
19XR / XRV single stage	421			<b>NEW</b> 61CW-Z	761
19XR / XRV double stage	425	<b>39</b>		61WG	613
		<b>NEW</b> 39CS	969	61XWH-ZE	769
<b>30</b>		39CP	993	Barrisol	1107
30KAV / 30KAVP	151	39CQ	979		
30KAV(P)ZE / 30KAVIZE	185	39CZ	1005	<b>Control Solutions</b>	
30RB 017-021	59	39HQ	1019	<b>NEW</b> 33ET	1137
30RB 026-040	69	39HX	985	33TZ	1133
30RB 040R-160R	77			Aquasmart Evolution	1151
30RB / 30RBP 170R-950R	101	<b>42</b>		Fan coil controls overview	1129
30RQ 017-021	503	42AM	815	NTC controllers	1143
30RQ 026-040	513	42EP	855	PlantCTRL™	1127
30RQ 040R-160R	539	42GW	903	Plant Sequencer	1121
30RQ-/30RQP 165-1040R	563	42KY	891	Smart Energy Monitoring	1119
30WG	633	42NC-ND	877	Thermal Energy Storage system	1155
30WG / 30WGA	305	42NL / NH	917	Thermostats	1131
				WTC controllers	1147



## CARRIER

Carrier is a world leader in HVAC, Refrigeration, Fire & Security solutions. For over a century, we have been developing innovative products and services that have changed the way people live and work. That drive for innovation continues today with a renewed focus on creating solutions that will change the world for the better. At Carrier, we see possibilities in everything.

# 04

## COOLING

Whether air conditioning is needed for a new building or a refurbishment project, for a commercial center, an office application or an industrial process, Carrier offers a wide range of solutions: air cooled, water cooled and absorption units, with scroll, rotary, screw and centrifugal compressors from 8 to 10,500 kW cooling capacity.

# 57

## HEATING

Carrier offers a vast range of heating solutions from air-to-water heat pumps to water-to-water heat pumps, with heating only or reversible capability, with scroll and screw compressors from 5 to 1,980 kW heating capacity. Carrier's heating machines are designed to deliver up to 120°C hot water temperature.

# 501

## AIR TREATMENT

An important aspect of any HVAC system is the correct supply of treated fresh air to the building occupants, improving indoor air quality (IAQ) levels. Carrier offers a vast range of close control units and packaged units, as well as standard and customized air handling solutions to ensure the best match to the requirements. Carrier also proposes a range of hybrid terminal, cassette, cabinet, concealed, ducted terminals to match any application requirements and installation criteria: in the room, in the ceiling, above a false ceiling, in a central plant room, and many more.

# 781

## CONTROLS

Carrier equipment and system controls are available for standard system applications and customized, tailor made projects. Carrier offers a wide range of control solutions covering all HVAC applications.

# 1117



# CARRIER

Carrier is the leading global provider of healthy, safe, sustainable and intelligent building and cold chain solutions. For over a century, we have been developing innovative products and services that have changed the way people live and work. That drive for innovation continues today with a renewed focus on creating solutions that will change the world for the better. At Carrier, we see possibilities in everything.



## Creating solutions that matter for people and our planet



### Innovation is in our DNA

At Carrier, we have a proud history of pioneering industries through innovation. Our leading world-class brands are the legacy of our founders, who invented technologies to meet real needs, turned them into businesses, and then innovated to lead entire industries.



### A Leading Legacy

Carrier was built on a legacy of innovation – beginning with our founders. We are innovators at heart and inventors by heritage. From the start, we've led in pioneering new technologies and in enabling entirely new industries that have changed the world. Today, building on our history of firsts, we're boldly advancing the industries we created to make a difference in people's lives.



**DISCOVER CARRIER ON**

[www.carrier.com/eu/](http://www.carrier.com/eu/)



# CARRIER'S HERITAGE: THE INVENTION THAT CHANGED THE WORLD

On July 17, 1902, Willis Carrier designed the first modern air-conditioning system to solve a problem at the Sackett & Wilhelms printing plant in Brooklyn, New York City, launching an industry that would fundamentally improve the way we live, work and play.



1904

Willis Carrier applied for a patent on his invention, an "Apparatus for Treating Air,"; he had invented the world's first spray-type air conditioning equipment, able to both wash and humidify or dehumidify air. Modern air conditioning now had its fundamental building block.



1911

Willis Carrier writes a "Rational Psychrometric Formulae" for the calculation of the wet temperature that quickly becomes the predecessor of the charts used today. He becomes internationally recognized.

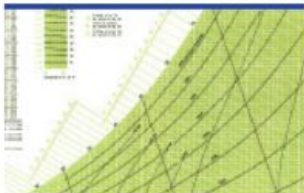

1917

Carrier hires America's first woman air-conditioning engineer, right around the time that the decision to allow U.S. women the right to vote was being debated by lawmakers.

1922

Carrier unveiled the first centrifugal chiller, which opened the door to large-scale comfort air-conditioning.



1926

Carrier introduces the first home air conditioner.

1931

Carrier takes the seas, with the M.V. Victoria, the first vessel to make its maiden voyage equipped with air conditioning.



1998

Willis Carrier is named one of Time magazine's "100 Most Influential People of the Century."

2016

Carrier launches the first high temperature water-to-water heat pumps using the next generation of refrigerants: HFO.

2018

Carrier opens its new world headquarters, the Center for Intelligent Buildings.

2020

The OptiClean™ Dual-Mode Air Scrubber & Negative Air Machine was named as one of TIME's 100 Best Inventions of 2020.







# 2030 ENVIRONMENTAL, SOCIAL & GOVERNANCE GOALS

Learn about our progress at

[corporate.carrier.com/esg-report](https://corporate.carrier.com/esg-report)

Our 2030 ESG goals underscore our commitment to the things that matter and to continuously challenge ourselves to think bigger and to be better. Expanding on three decades of environmental targets, our goals include measures to improve our planet, our people and our communities. We strive to be a catalyst for positive and sustainable change as we innovate, empower our people and operate with integrity. That is *The Carrier Way*.

## OUR PLANET

Climate change is among the most significant issues facing humanity. HVAC contributes an estimated 15% of the world's greenhouse gas emissions. More than one-third of all food produced is wasted every year, resulting in an estimated 4.4 gigatons of greenhouse gas emissions. We recognize the potential for smart, sustainable innovation, and are committed to setting science-based emissions targets aligned with the goals of the Paris Agreement.

- Reduce our customers' **carbon footprint** by **more than 1 gigaton**.
- Invest over **\$2 billion** to develop **healthy, safe, sustainable and intelligent building and cold chain solutions** that incorporate **sustainable design principles and reduce lifecycle impacts**.
- Achieve **carbon neutral** operations.
- Reduce **energy intensity** by 10% across our operations.
- Achieve **water neutrality** in our operations, prioritizing water-scarce locations.
- Deliver **zero waste** to landfill from manufacturing locations.
- Establish a **responsible supply chain program** and assess key factory suppliers against program criteria.

## OUR PEOPLE

Our greatest strength is the diversity of our employees and their ideas. We are a company of innovators and problem-solvers who are united by *The Carrier Way* – our purpose, values and culture.

- Exceed benchmark **employee engagement**.
- Achieve **gender parity** in senior leadership roles.
- Achieve a **diverse workforce** that represents the communities in which we live and work.
- Foster the growth of **Employee Resource Groups** to drive social impact.
- Maintain world-class **safety metrics**.

## OUR COMMUNITIES

Decades of leadership in sustainability have guided Carrier to the forefront of healthy buildings, healthy homes and a more connected cold chain. Throughout our global operations, we are reducing our environmental footprint and making investments that have a positive impact on society.

- Positively impact communities by enabling access to **safe and healthy indoor environments, alleviating hunger and food waste, and volunteering our time and talent**.
- Invest in **science, technology, engineering and math education** programs that promote **diversity and inclusion**.
- Promote **sustainability** through education, partnerships and climate resiliency programs.

# SUSTAINABILITY

At Carrier, we are driving sustainability in buildings and homes and across the cold chain. We continue to deliver innovative products and services that help customers avoid greenhouse gas emissions, while reducing our own environmental footprint throughout our global operations.



## SPOTLIGHT MONTLUEL

We renovated the test lab in our Montluel, France, facility, where we make and test chillers.

The renovations included the installation of our high-efficiency AquaForce chillers, which are variable speed drive chillers optimized by our controls to adapt to energy need and operating conditions, such as weather.

We also shifted the refrigerant used to a lower global warming potential and nonflammable refrigerant, R-515B(E), and installed our energy-efficiency dry coolers, which replaced cooling towers that have been dismantled.

The renovation resulted in a 25% reduction in the facility's annual energy consumption and the reduction of water use by nearly 1.2 million gallons per year in the test lab.

# THE CARRIER WAY

The Carrier Way is the foundation of everything we do. It defines our vision, reaffirms our values, describes the behaviors that create a winning culture, and establishes how we work and win together.

## The Carrier Way

### VISION

Our aspiration; why we come to work every day.

Creating solutions that matter for people and our planet.

### VALUES

Our absolutes; always do the right thing.

Respect Integrity Inclusion Innovation Excellence

### CULTURE

Our behaviors; how we work and win together, while never compromising our values.

#### Passion for Customers

We win when our customers win.

#### Play to Win

We strive to be #1 in everything we do.

#### Choose Speed

We focus and move with a bias for action.

#### Achieve Results

We perform, with integrity.

#### Dare to Disrupt

We innovate and pursue sustainable solutions.

#### Build Best Teams

We develop diverse teams, and empower to move faster.



# CARRIER, LEADING INNOVATION

Carrier constantly builds upon its history of proven innovation with new solutions in air conditioning, building controls and energy services, setting the standard for performance, energy efficiency and sustainability.

## Ideas for an inspired tomorrow

HVAC challenges aren't always as common as you might expect, and our engineers work to ensure we can all take reliable, efficient environmental control for granted—from cultural heritage preservation to heat recovery application for district heating, with the next generation heating, cooling and technologies. Evaluating and applying advanced refrigerants and developing control algorithms to optimize performance isn't taken for granted here, and our engineer's work provides security to everyday living.

## Ultra-modern laboratories

Carrier's laboratories, among the largest such facilities dedicated to HVAC in Europe, and Research & Development teams, are an important part of what makes the company a natural leader. Carrier benefits from unique facilities, both in terms of cooling coverage, air treatment capacities and measurement accuracy.

## Innovative projects throughout Europe



### Raphael's Rooms, Vatican city state June 2020

#### *Air-conditioning application*

Over a three-year period, Carrier engineers worked closely with the Vatican's technical teams to create an entirely new fan coil and casing design that packed 10kW of cooling capacity into the footprint of a 2.5kW unit. These new coils were installed underneath the windows in the Raphael's Rooms using pre-existing settings, remaining invisible to visitors.

▶ Discover the Raphael's Rooms project on [https://youtu.be/l2le4rgzXec?si=yGs8wrcmZi1Wuy\\_f](https://youtu.be/l2le4rgzXec?si=yGs8wrcmZi1Wuy_f)



© Bahnhof - www.bahnhof.net

### Bahnhof, Stockholm, Sweden January 2014

#### *District heating, heat recovery application in three data centers*

Carrier AdvanTE3C engineers, working closely with the Swedish Internet service provider Bahnhof and hydraulic specialists have helped to optimize an innovative cooling & heating solution turning data centers into heat sources for local district heating systems.

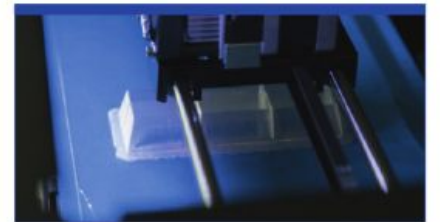
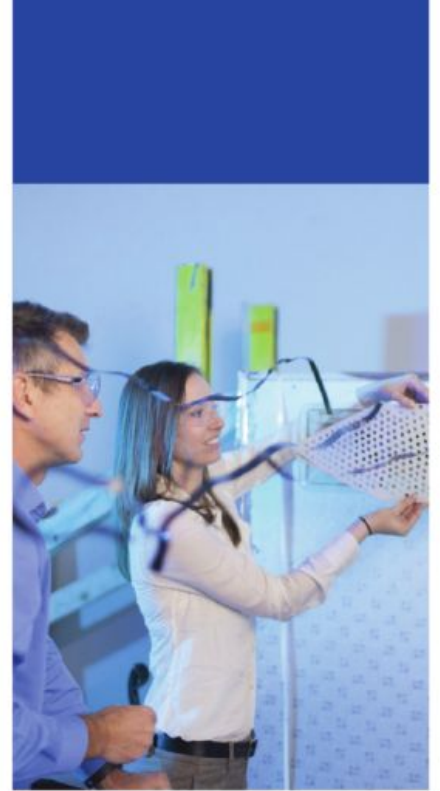

### CADZIPL0, Geneva, Switzerland, August 2015

#### *Europe's first screw water-to-water heat pumps using HFO*

Carrier has set a new milestone with Europe's first district heating project based on screw water-to-water heat pumps using low Global Warming Potential PUREtec™ refrigerant: HFO R-1234ze(E).

▶ Discover the story of CADZIPL0 project on <https://youtu.be/kLJgLeBD8uQ>



# CARRIER, HVAC IN EUROPE

Carrier's commercial HVAC presence in Europe, continuous innovation and constant investment in research and technology, along with a customer-focused philosophy, have led Carrier to the top of the European HVAC market for decades and continue to strengthen its position.

The group is active in equipment and service businesses under the brand names Carrier and CIAT. BluEdge® is the brand for Carrier and CIAT service.



## Culoz

Airside products



## Montluel

Commercial Heat pumps and Chillers



## Vence

Control systems & Connected services



## Montilla

Rooftops & Light Commercial Heat pumps



## AT A GLANCE



**HEADQUARTERS**  
MONTLUEL, France



**~4,000**  
EMPLOYEES



**2** MAJOR BRANDS  
Carrier & CIAT



**TOP 3** MARKETS  
France, UK & Iberica



**\$1.0B**  
2022 NET SALES



DIRECT SALES OFFICES  
IN **12** COUNTRIES



**50** INDEPENDENT  
DISTRIBUTORS



**3** FACTORIES



**4** CENTERS  
OF EXCELLENCE



**1** EUROPEAN  
PART CENTER  
WITH **12,000**  
ITEMS IN STOCK



# MONTLUEL CENTER OF EXCELLENCE: Heat pumps and chillers expertise

The European Research and Design center and laboratory in Montluel, France, can design, choose and qualify the best technologies that would meet markets requirements and upcoming regulations.

Built in 1985 and covering 7 500 m<sup>2</sup>, it is capable of simulating the widest range of operating conditions encountered by heat pumps and chillers equipment. Montluel center of excellence is one of the most advanced and rigorous testing facilities in the world, ensuring that only the highest levels of quality and reliability are achieved.

## Modeling Analysis Simulation & Computation (MASC)

The center's numerical simulation platform capabilities include Model-Based Definition (MBD), Computational Fluid Dynamics (CFD), Finite Element Analysis (FEA) and 3-D design.

## Customization

The center has a dedicated customization team specializing in bespoke solutions to meet the chiller and heat pump needs of each customer. This includes applied engineering in fields such as seismic, nuclear, marine or offshore applications.

## Prototypes & Tests

It carries out prototyping modifications, tests for internal development projects and customer acceptance tests of products performance at any condition required by the application.

## 15 Test Rooms

- Thermal, performance, endurance and acoustic tests
- A/C and W/C Chillers, as well as terminal units
- Ambient control from **-20°C to +55°C** with humidity conditions of **5% to 95%**
- **1 200** measurement sensors
- **3 600 kW** maximum water-cooled unit test capacity
- **1 800 kW** maximum air-cooled unit test capacity
- **6 MW** total test capacity

- Ability to reach and maintain stable conditions
- High-precision method for acoustic measurement
- Specific tests on request

## Remote Testing

The center offers customers the possibility of witnessing the test from anywhere in the world. We connect with customers digitally, creating an environment where they feel that they are really in the laboratory.

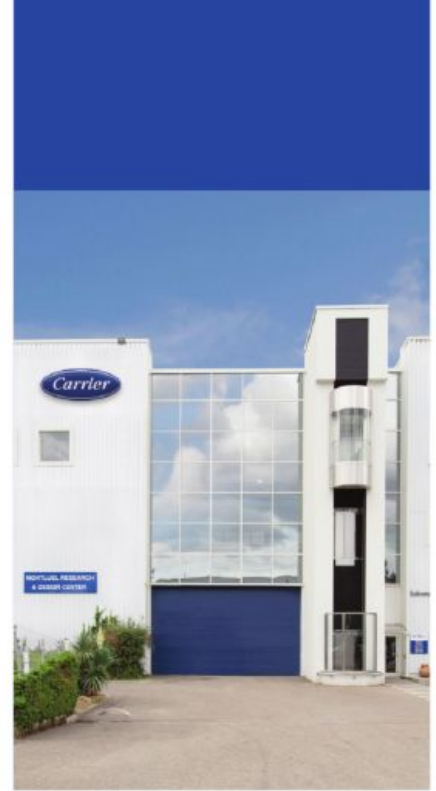

## CERTIFICATIONS

Quality Management System

**ISO 9001:2015**

Approved by Lloyd's Register Quality Assurance

Environmental Management System  
Quality System & case-by-case

**PED 2014/68/EU**

Approved by Bureau Veritas

Air-cooled & water-cooled  
performance

**ISO 14001:2015**

Approved by Lloyd's Register Quality Assurance

**Marine Application**

Approved by Lloyd's Register, Det Norske Veritas (DNV) & Germanischer Lloyd's (GL).

**AHRI**

Approved by AHRI, America reference label of the energy performance of air conditioning and refrigeration equipments

**EUROVENT**

Approved by Eurovent Certita Certification, European reference label of the energy performance of air conditioning and refrigeration equipments. Liquid Chilling Packages and Heat Pumps (LCP-HP) program.

# CULOZ CENTER OF EXCELLENCE: Airside expertise

The Research and Design center and laboratory in Culoz are fully dedicated to airside solutions. The investment strategies Carrier has implemented in recent years, have allowed Culoz to rank among the top R&D centers in the sector.

This 4 000 m<sup>2</sup> center performs all types of customer acceptance tests on any product (AHU, Dry Cooler, TFCU... ) and is able to reproduce the exact customer office to determine the actual comfort level and optimize it if necessary.



## Indoor Environmental Quality

- Acoustic platforms
- Comfort test platform (Units and air diffusers according to EN ISO 7730 and EN 15726)
- Indoor Air Quality platform

## Dry Coolers

- Thermal rating up to 2 000 kW
- Acoustic and adiabatic cooling
- Possible to test water to water heat exchangers

## Air Handling Units

- Model Box performance under standard EN 1886
- Airflow tests (standard ISO 5801) up to 35 000 m<sup>3</sup>/h & 1 000 Pa
- Control software validation
- Sound tests (standard ISO 9614-1)
- Thermal performance tests (standards NF EN 1397, EN 14511) up to 200 kW / 56 000 m<sup>3</sup>/h

## Terminal Fan Coil Units

- Sound tests (standard ISO 9614-1)
- Thermal tests (standard NF EN 1397) -5°C to +50° / up to 20 kW
- Air flow tests (standard NF EN 5801)

## Reliability Tests

- 24/7 corrosion tests
- Static, cycling or burst hydraulic pressure tests up to 250 Bar
- Vibration tests with a maximum force of 2 000 N
- Endurance testing of fan coil units



## Heat recovery system and coils test platform

- Heat recovery efficiency and thermal capacity test
- Airflow capacity up to 30 000 m<sup>3</sup>/h pressure drop
- Thermal capacity up to 300 kW

## Numerical simulations

- Computational Fluid Dynamic (CFD)
- Indoor comfort simulation

## CERTIFICATIONS

Quality Management System

**ISO 9001:2015**

Approved by Lloyd's Register Quality Assurance

**PED 2014/68/EU**

Certified by Apave & Bureau Veritas

**DAP 08.D /DAP 13.C**

Certified by Efectis

Environmental Management System

**ISO 14001:2015**

Approved by Lloyd's Register Quality Assurance

Safety Management System

**ISO 45001:2018**

Approved by Lloyd's Register Quality Assurance

Product performance

**EUROVENT**

Approved by Eurovent Certita Certification, European reference label of the energy performance of air conditioning and refrigeration equipments. Terminal Fan coils Units (TFCU), Air Handling Units (AHU), and Heat exchangers (HE) programs.





# MONTILLA CENTER OF EXCELLENCE: Rooftops and light commercial chillers expertise

Our teams in Montilla, Southern Spain, have in-depth expertise in rooftop, packaged and dehumidifier units. The center offers specialized laboratories, as well as one of Europe's biggest aircraft preconditioner air units laboratory.

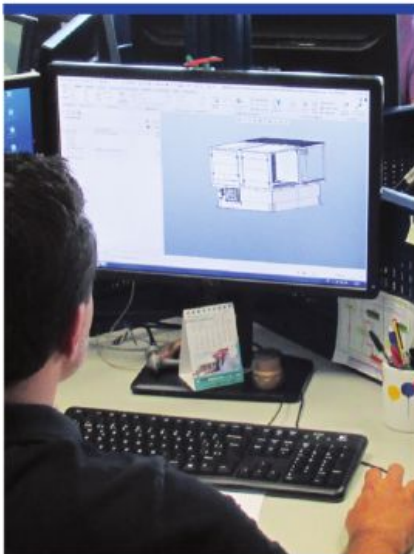
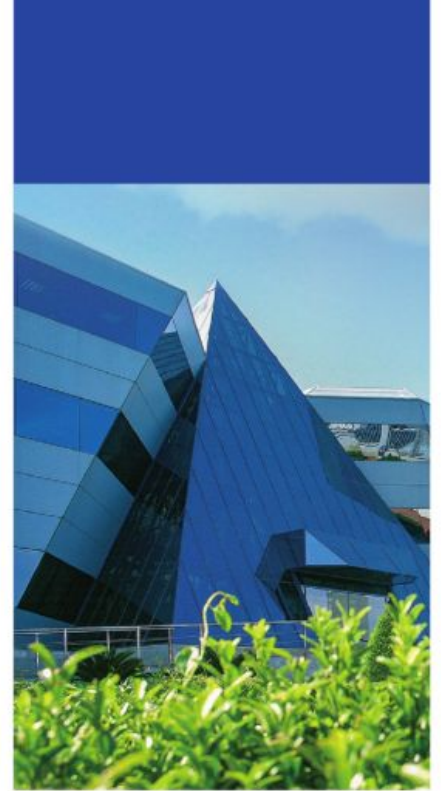

## Modeling Analysis Simulation & Computation (MASC)

The Montilla center of excellence offers numerical simulation capabilities in Model-Based Definition (MBD), Computational Fluid Dynamics (CFD) and 3-D design.

## Customization

An engineering team is specifically dedicated to customization projects. The center can also offer technical data acquisition for technical documentation, as well as remote test supervision for special on-site applications.

## Prototypes & Tests

The center carries out prototyping and testing for our development team. It performs thermal, acoustic and vibration tests (2 test rooms), ambient control tests from -15°C to +55°C and specific tests for preconditioned air for aircraft and swimming pool dehumidification units.

## CERTIFICATIONS

Quality Management System	<b>ISO 9001:2015</b>	Approved by IQNET and AENOR
Environmental Management System	<b>ISO 14001:2015</b>	Approved by Lloyd's Register Quality Assurance
Health & Safety Management System	<b>ISO 45001:2018</b>	Approved by Lloyd's Register Quality Assurance
Performances	<b>EUROVENT</b>	Approved by Eurovent Certita Certification, European reference label of the energy performance of air conditioning and refrigeration equipments . Rooftops (RT), Terminal Fan coils (TFCU) and Air Handling Units (AHU) programs.
Pressurized Equipment Directive	<b>PED 2014/68/EU-Module H</b>	Approved by Bureau Veritas

# VENCE CENTER OF EXCELLENCE: Control systems and remote connectivity services

Located in the South-East of France, the strength of Vence center of excellence is its engineering expertise in controls, automation and digital solutions as IoT and connected services with in depth knowledge of HVAC applications.

## Remote Connectivity Services - Abound™ HVAC Performance

The team is in charge of remote monitoring and predictive maintenance solutions using AI with more than 7,000 connected equipment. Our engineers focus on developing and offering technical support for Connected Services i.e. remote connectivity Solutions to our European distribution network. This new digital offering, which is added to existing BluEdge service agreements, connects customers' equipment to Carrier's cloud based IoT platform, providing them with advanced analytics and actionable insights to visualize, advise and optimize machine health and life cycle outcomes.

## i-Vu® Controls Solution for Plant Room

The team supports the i-Vu controls business of Carrier in Europe around the Plant Room. We bring technical support during the design & engineering phase of plant room control system and develop and promote new controls offers for Carrier customers. On a project by project basis, we also support the design of Plant Room with thermal energy storage (TES). The team's know-how is unique and proven with dual cooling/heating and controls/automation in-depth knowledge.

## Training Center

The Vence Center of Excellence is managing Carrier's training center for service technicians in Europe. We train technicians on products, service tools, digital, IoT and control solutions to develop their skills and expertise. Trainings can be done remotely through webinar or e-learning modules or on site on training platforms designed specifically.

## R&D Connections

The Vence center of excellence works closely with Europe's leading Science Park, located in Sophia-Antipolis in Southern France. Our team has been involved in several European research and innovation projects.



**+ 7,000**  
CONNECTED  
APPLIANCES



**+ 500**  
PLANT ROOM  
CONTROL SYSTEMS  
(i-Vu & PlantCTRL™)



# CARRIER, MEETING THE CHALLENGE OF REGULATORY AND ENVIRONMENTAL CHANGES



Carrier is committed to limiting the environmental impact of its products and solutions and reducing energy consumption. This commitment is in line with the targets of the European Union to be climate-neutral in 2050.

Climate change is among the most significant issues facing humanity. To overcome this challenge, the European Commission proposes ambitious targets in terms of energy efficiency and greenhouse gas emissions.

The REPowerEU initiative seeks to diversify energy supply to better face energy price uncertainty and to speed up renewable, clean energies and electrification.

These objectives strongly influence the HVAC market. The industry has to comply with high demanding regulations (such as Ecodesign and F-Gas) and must anticipate the future market trends (decarbonization).

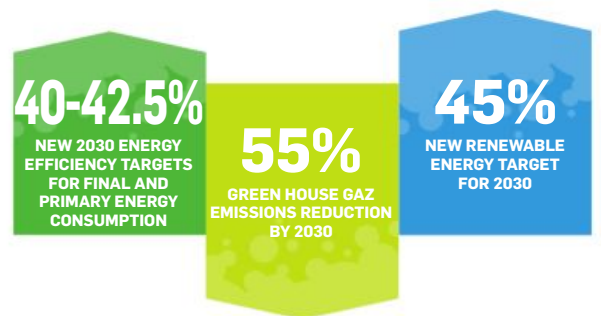

## Mastering energy efficiency with Ecodesign

In order to achieve the energy efficiency target, the European Union has developed a regulation to reduce energy consumption in buildings: **Ecodesign**.

Indeed buildings are the largest consumers of energy today and, of that consumption, HVAC systems account for considerably more than other equipment. Providing customers with energy efficient solutions is therefore now a key sustainable development opportunity for the HVAC industry.

### ECODESIGN

Ecodesign is an approach to product design that encourages manufacturers to consider the environmental impact of the product over its entire lifecycle.

In the European Union, the Ecodesign Directive 2009/125/EC establishes a framework for the setting of mandatory energy efficiency requirements for all energy-related products (ERPs). For more information visit [www.ecodesign-hvac.com](http://www.ecodesign-hvac.com)

#### Regulation 1253/2014

has been setting energy efficiency requirements since 2016 for **ventilation units** equipped with filters, energy recovery devices, fans and motors. The requirements were reinforced in January 2018.

#### Regulation 2016/2281

sets energy efficiency requirements and informative requirements for **chillers up to 2,000 kW used in air conditioning applications for comfort cooling**, and for **air conditioners, rooftops and packaged units in comfort cooling**

**and space heating applications.** It also sets energy efficiency requirements for **industrial process cooling chillers up to 2,000 kW** with a positive leaving water temperature. It came into force in January 2018 and has been reinforced in January 2021.

#### Regulation 2016/2281

has introduced energy efficiency requirements in 2016 for **industrial process cooling chillers** with negative leaving temperatures and has been reinforced in July 2018.

#### Under regulation 813/2013

**air- and water-to-water heat pumps up to 400 kW** must comply with higher energy efficiency requirements as from September 2017. **Heat pumps up to 70 kW must also carry Energy Labelling** in line with regulation 811/2013 from September 2015 onwards.



## Air Handling Units: overall product improvement

Since 2016, air handling units must comply with Ecodesign technical and minimum efficiency requirements as well:



ENERGY EFFICIENCY /  
SPECIFIC FAN POWER



INDOOR  
AIR QUALITY



ENERGY  
RECOVERY



INFORMATION

## Chillers, heat pumps, roof-tops and air conditioners: New metrics because seasonal efficiency matters

With all new construction to be nearly zero energy building from January 2021 onwards, the HVAC industry needs new accurate indicators to express the energy efficiency of equipment. These indicators must be representative of actual operations throughout the year, measuring the performance of equipment on a seasonal basis.

**EER & COP belong to the past.** Now and in the future, the focus is on seasonal efficiency. With a broad new product range, Carrier is fully engaged to take up the challenge of energy efficiency.

**Compliance with the Ecodesign regulations therefore involves the use of new, more meaningful seasonal efficiency metrics.** The Seasonal Energy Efficiency Ratio (**SEER**), Seasonal Energy Performance Ratio (**SEPR**) and Seasonal Coefficient of Performance (**SCOP**) all ensure precise evaluation of the energy actually consumed by chillers and heat pumps, by including seasonal variations in their measurements. Previous metrics (EER & COP) measured operations only at a single point, at full thermal load, and were therefore less representative of consumption over entire heating and cooling seasons.

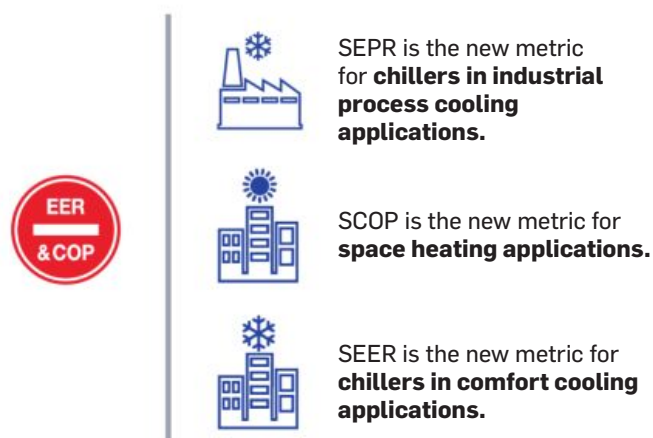

### Etas ( $\eta_s$ ):

In order to **compare the energy efficiency of products using different sources of energy**, the Ecodesign regulation introduces a new measurement expressed in primary energy:  $\eta_{sc}$  is the equivalent of SEER for comfort cooling applications and  $\eta_{sh}$  is the equivalent of SCOP for space heating.

These new seasonal performance metrics are now the key indicator used for all product ranges, in all applications. They are calculated according to technical standard EN 14825 and compliance is mandatory for a product to obtain CE marking.

## Energy Labelling

In addition; European Energy Labelling regulation 811/2013 classifies heat pumps up to 70 kW from D to A+++, according to their energy efficiency. This enhanced consumer information drives the market towards more energy-efficient products.

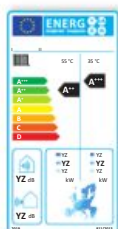

UP TO  
**25%**

above the  
Ecodesign  
requirements

**CARRIER, EXCEEDING  
THE MOST  
CHALLENGING  
REQUIREMENTS**

Carrier's solutions are not only compliant with Ecodesign requirements, but can exceed them by up to 25%.



# REDUCING THE CARBON FOOTPRINT WITH F-GAS REGULATION

The challenge raised by the European Union's F-gas regulation means the entire industry must move to a new generation of refrigerants, that will not only protect the ozone layer but also have a very low global warming impact. Carrier is facing this challenge head on.

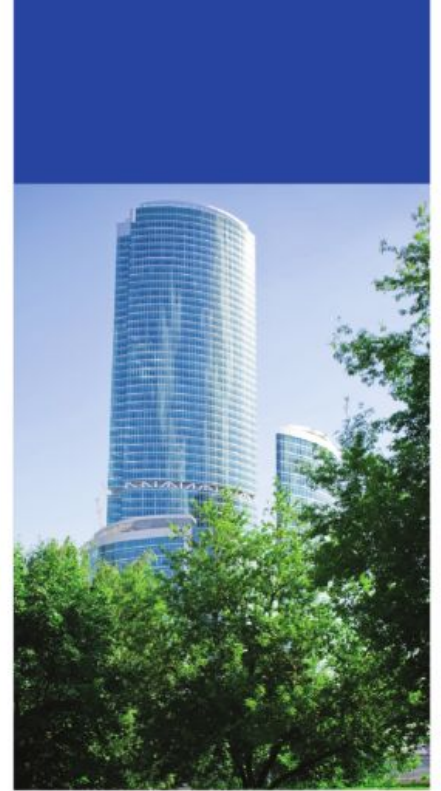

## The European F-Gas Regulation 2014 / 2023\*

By 2014 the regulation introduced bans for certain equipment using HFCs and a phase down scheme for HFCs placed on the European market.

In 2023, a revision of the current regulation is upon to be implemented with target to accelerate further the decrease of CO<sub>2</sub> emissions and lowering the global warming potential to achieve 95% reduction by 2030 and 0 emission by 2050.

The new F-Gas revision is intended to be voted in 2024, for entry into force by January 2025

As a consequence, new bans shall be implemented to limit GWP with threshold 150 on CML and industrial heat pumps by 2027, and 750 for chillers above 12kW by 2030.

These new GWP limits are subject to derogation in order to comply with European and National / Local specific building codes and safety requirements.

No specific bans related to stationary equipment air conditioning, heat pumps and chillers for service, maintenance, and repairs under certain conditions ( GWP < 2500, use of reclaimed and / or recycled refrigerants, ...)

Carrier already anticipates more stringent regulations to phase down high GWP refrigerant.

European Unions' targets HFC consumption related to CO<sub>2</sub> equivalent

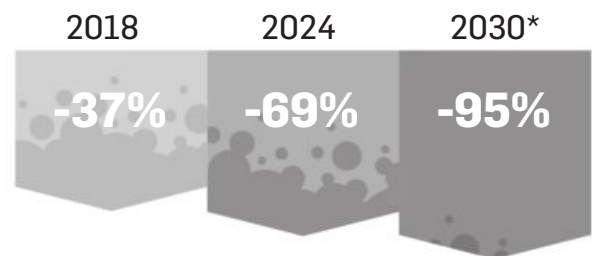

\* At time catalogue is released, the new F-Gas revision may be subject to adjustments until it is finally voted by Council of EU and EU parliament and the local country implementation.

## Carrier, always forward-thinking

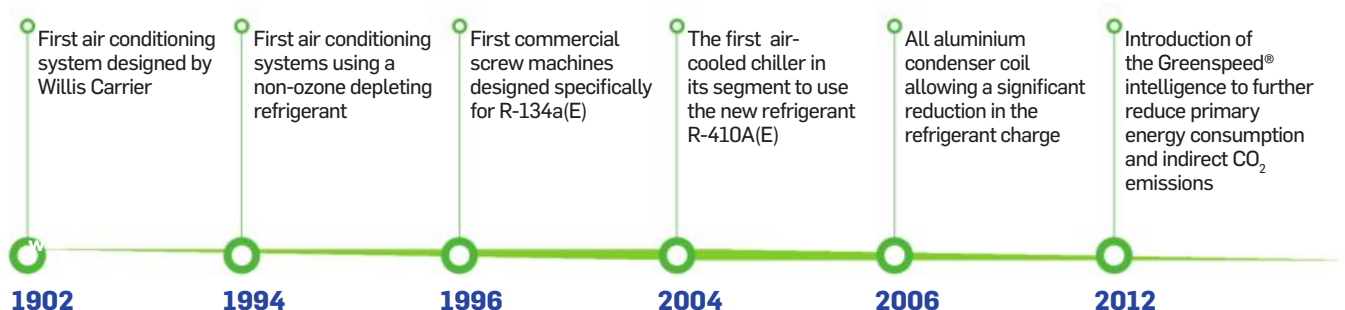

## PUREtec™ HFO refrigerant solutions

With PUREtec, Carrier offers a range of long-term sustainable and efficient solutions using HFO refrigerants with zero impact on the ozone layer and ultra-low impact on global warming: HFO R-1234ze(E) for screw units and R-1233zd(E) for centrifugal units.

After the first HFO water-cooled screw chiller installed in Europe in 2016, Carrier has sold more than 1200 projects across Europe in multiple applications such as industry, data centers, district heating and healthcare.

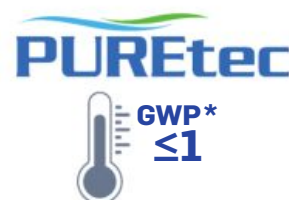

\* GWP according to AR5 from the IPCC (International Panel on Climate Change)

Building on its success, the PUREtec family has grown from the Carrier AquaForce PUREtec 61XWHZE high-temperature heat pumps range, to the AquaEdge™ 19DV centrifugal chillers and now to the new generation of AquaForce PUREtec 30KAV/P-ZE and 30XB/P-ZE premium air-cooled screw chillers.

## Lower GWP refrigerant solutions (Blends, R-32(E))

Carrier has selected a family of lower GWP refrigerants for use in chillers, heat pumps and rooftop packaged units to offer optimum solution in terms of total environmental impact, cost, safety and ease of use. The selection aligns with Carrier's 2030 environmental, social and governance goals to reduce its customers' carbon footprint by more than 1Gt.

• Carrier has selected **R-32(E) refrigerant to replace R-410A(E) refrigerant in commercial chillers**

**using scroll technology.** Carrier's use of R-32(E) refrigerant and expert system design will reduce the refrigerant carbon footprint by up to 80%.

• Carrier is one of the first manufacturers to offer **screw water-cooled chillers and heat pumps operating on the new low GWP refrigerant R-515B(E)**, which provides a number of important benefits for end users. With an A1 safety classification, R-515B(E) is

both non-flammable and non-toxic and has a GWP of less than 300.

- Carrier is offering **R-513A(E) refrigerant**, which has a GWP of 573, **on 19XR(V) centrifugal chillers.**
- The blend **R-454B(E) is the optimum solution for use in rooftop applications.** R-454B(E) is a lower flammability A2L refrigerant blend with a GWP of 466.

## NATURAL REFRIGERANTS

Carrier has been a pioneer in the use of the natural refrigerant, CO<sub>2</sub>, for commercial refrigeration applications including cabinets and racks. Also known as R-744(E), CO<sub>2</sub> is a non-flammable and non-ozone depleting refrigerant and has a GWP of just one. The first Carrier CO<sub>2</sub> system was installed in 2004 in a supermarket in Switzerland. CO<sub>2</sub> mechanical systems continued to gain traction over the years.

For the medium and small heat pump ranges, Carrier has also selected R-290 natural refrigerant, featuring a nearly zero Global Warming Potential (GWP of 3).

With a significantly lower refrigerant charge compared with traditional refrigerants, R-290 natural refrigerant offers higher efficiency for high temperature applications and represents an environmentally sustainable choice, reducing equivalent emissions of CO<sub>2</sub> by 99,9%.

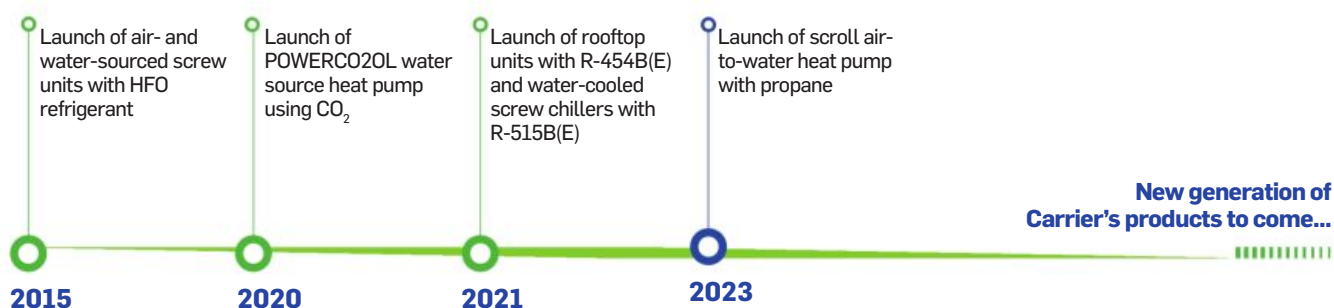





# DECARBONIZING HEATING IN THE COLLECTIVE HOUSING, COMMERCIAL AND INDUSTRIAL SECTORS



## Europe to end fossil fuel heating by 2050

Heating is one of the EU's most energy-intensive sectors: 64% of the total energy consumed in the EU is used for heating space and water\*. If Ecodesign and energy labelling is set to deliver a third of the EU's 2050 climate-neutral target, the European Commission must also put heating on the right path by phasing out fossil fuel boilers beyond 2030.

\*<https://ec.europa.eu/eurostat/web/products-eurostat-news/-/ddn-20190620-1>

## Carrier's commercial heating vision

In order to support the EU 2030 target of a 55% reduction in greenhouse gas emissions and the EU 2050 carbon neutral target, the commercial heating industry in Europe will need to make a major technology transition from fossil fuel boilers to more sustainable heating systems.



Industrial heat pumps  
for district heating



Commercial heat  
pumps > 20kW



Green boiler  
technologies



Fossil fuel commercial  
boilers > 60kW

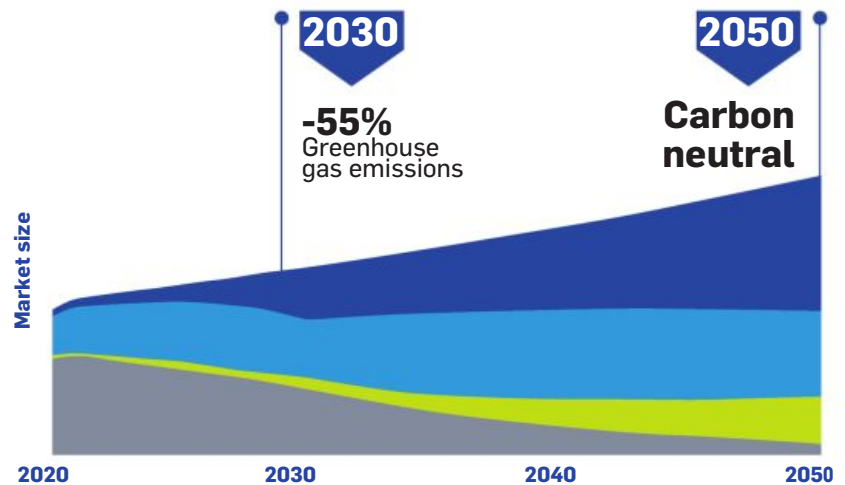

Market trend evolution based on Carrier estimates



## FOSSIL FUEL BOILER DECLINE

More than 60% of European building sector are still heated with fossil fuel commercial boilers using natural gas or oil in 2020 \*.

Beside their high carbon footprint, fossil fuel technologies will have to face increasing EU and local regulations as well as uncertainty regarding their prices and availability in the future. These technologies are coming to an end and the transition must start right away.

«\*Iea, Are renewable heating options cost-competitive with fossil fuels in the residential sector ?, <https://www.iea.org/articles/are-renewable-heating-options-cost-competitive-with-fossil-fuels-in-the-residential-sector>. Published on 1 December 2021.»



## GREEN BOILER CHALLENGES

“Green” boiler technologies shall replace a portion of fossil fuel boilers. Nevertheless, they will need to overcome several technical challenges over the next years:

**Hydrogen boilers** are still in development and construction of ‘hydrogen-ready’ distribution networks in cities will take decades.

**Biomass boilers** might be a shorter-term solution, but with inconvenient operation and maintenance: they need to be cleaned every week, and owners will have to continuously supply the system with pellets or chips and remove the ashes, and the fuel needs space to be stored.



## COMMERCIAL HEAT PUMPS

Individual heat pumps are one of the most efficient appliances on the market for heating residential developments or buildings. Reversible air source heat pumps are the best solution for sustainable cooling and heating in buildings.

Carrier already offers a complete range of heat pumps for commercial applications up to 82°C.



## INDUSTRIAL HEAT PUMPS FOR THE DISTRICT HEATING AND PROCESS HEATING SECTORS

Forecasts indicate that 84% of European citizens will live in urban areas in 2050 \*. Future heating solutions must therefore prioritise urban applications for greater environmental benefits. The EU Heat Roadmap considers increasing smart heating and cooling networks to 30% by 2030 and to 50% by 2050 as essential milestones in achieving ambitious decarbonisation goals.

In 2020, hundreds of large industrial heat pumps capable of producing hot water at 70°C, 90°C or higher temperatures were installed in various European district heating zones. A new generation of very high temperature heat pumps capable of producing hot water up to 120°C will also be rolled out to replace fossil fuel industrial boilers and steam boilers for process heating in various industries including food, drying processes, biogas processes and chemical plants. These large industrial heat pumps use renewable energy from water or the ground, as well as waste energy from buildings, processes and data centres to provide heating. Heat pumps have helped to drastically reduce CO<sub>2</sub> emissions in these projects, as the electricity comes from renewable

sources and saves millions of litres of fuel every year. Most owners are eligible for financial aid, which can cover up to 60% of the amount of the distribution network in some countries.

Carrier is the European leader in the supply of commercial heat pumps above 50 kW. Several years ago, Carrier entered the specific market of large-scale industrial heat pumps capable of delivering hot water up to 85°C using ultra-low GWP HFO-1234ze refrigerant for district heating applications, selling over 200 units and receiving ACR Awards in 2022 for a prestigious decarbonisation project in London.

Carrier will continue to invest massively in the development of next-generation heat pumps benefiting from the latest technology innovations: ultra-low GWP and natural refrigerants, premium efficiency and very high temperatures up to 120°C.

\*Dacey, J. (2020), Europe targets 100 climate-neutral cities by 2030, Eos, 101, <https://doi.org/10.1029/2020EO151719>. Published on 17 November 2020.



# AQUASNAP® AND AQUAFORCE® 61 RANGE FOR MULTIPLE HEATING APPLICATIONS

The Carrier AquaForce and AquaSnap 61 heat pump range harnesses both natural and waste heat sources to offer sustainable energy solutions for multiple heating applications.

AquaForce and AquaSnap heat pumps use renewable air, water and ground energy sources to offer smart cities a more sustainable energy supply solution.

Delivering hot water up to 120°C, the heat pumps can supplement traditional boilers in applications such as commercial building heating, district heating and industrial process heating.



UP TO  
120°C



RENEWABLE  
ENERGY



FINANCIAL  
INCENTIVES &  
LOW TOTAL COST  
OF OWNERSHIP



ENVIRONMENTALLY  
SUSTAINABLE



NO NOISE &  
GAS POLLUTION



INDEPENDENT  
OF FOSSIL FUEL  
PRICE RISES

## SMART HEATING



WATER/GROUND SOURCES

From 7°C to 50°C

DISTRICT HEATING

Up to 120°C



Air  
-20°C



INDUSTRIAL  
WATER WASTE  
From 30°C to 60°C

HEAT  
RECOVERY

HEATING

DATA CENTERS

From 20°C to 30°C

COMMERCIAL  
SPACES

Up to 55°C

INDUSTRIES

Up to 120°C

HOUSING

Up to 45°C

ADMINISTRATION

Up to 55°C





## Commercial heat pumps

### AQUASNAP 61CG



High temperature  
water source heat pumps  
30 to 130 kW  
Hot water up to 82°C

### AQUASNAP 61WG



High temperature  
water source heat pumps  
29 to 230 kW  
Hot water up to 65°C

### AQUASNAP 61AF



High temperature  
air source heat pumps  
26 to 102 kW  
Hot water up to 65°C

## Public sector decarbonisation scheme for schools using Carrier AquaSnap 61AF heat pumps in London

More than 180 Carrier AquaSnap 61AF air-to-water heat pumps have been deployed in 60 schools in London and in Dudley in the West Midlands. It is part of the UK's Public Sector Decarbonisation Scheme (PSDS) to decarbonise heating in schools and other public buildings. The aim is to reduce carbon emissions and energy running costs as part of a major decarbonisation project.



## Industrial heat pumps

### AQUAFORCE 61CA



High temperature  
air source heat pumps  
410 kW  
Hot water up to 82°C

### AQUAFORCE 61XWHZE



High temperature  
water source heat pumps  
for district heating  
300 to 1570 kW  
Hot water up to 85°C

### AQUAFORCE 61CW-Z



High temperature  
water source heat pumps  
410 kW to 735 kW  
Hot water up to 92°C

### AQUAFORCE 61CWD



Ultra-high temperature  
water source heat pumps  
110 kW to 540 kW  
Hot water up to 120°C

## Carrier AquaForce 61XWHZE HFO heat pumps chosen to help decarbonise the city of London

Air Conditioning Project of the Year 2022 (ACR News), AquaForce 61XWHZE water-to-water heat pump support Carrier's aims to cut carbon emissions from heating and cooling and improve air quality in the capital. Three heat pumps have been installed and will extract thermal energy from water pumped from deep boreholes in the aquifer 200 metres beneath the capital. These units upgrade the energy harvest to produce hot water at 80°C. It will be used to provide up to 4 MW of cooling to residential and business customers via a 10-kilometre district-wide network of highly insulated underground pipes.





# CARRIER HEALTHY BUILDINGS PROGRAM

As a founding member of both the U.S. Green Building Council® and the International WELL Building Institute, Carrier has long been an industry leader in enhancing building health to promote personal health. Now, it is essential that the world have the solutions and services that enable healthy indoor environments.

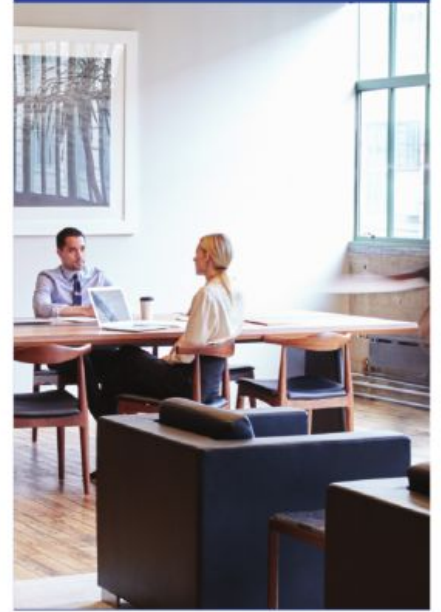

## The science of healthy buildings

As humans, we spend 90% of our time indoors. Consequently, buildings play a significant role in our lives and directly impact our health. Through the COGfx Study, research has shown that healthy buildings can significantly improve cognitive function.

In addition, healthy buildings can impact the bottom line for a business – from reducing energy waste and the related costs to increasing worker productivity.



# HEALTHYBUILDINGS

## Building on foundations

Healthy Buildings focus on addressing foundational aspects of the indoor environment to positively impact the people inside. Dr. Joseph Allen and a multidisciplinary team of experts from the Healthy Buildings Program at the Harvard T.H. Chan School of Public Health have identified these key areas as “The 9 Foundations of a Healthy Building.” Based on the 9 Foundations, we’ve outlined actions building owners and operators can take to make their building a healthy building.

 <p><b>VENTILATION</b></p> <p>Maximize outdoor air ventilation Monitor and control target ventilation</p>	 <p><b>AIR QUALITY</b></p> <p>Implement multipoint IAQ monitoring Incorporate advanced IAQ controls</p>	 <p><b>THERMAL HEALTH</b></p> <p>Design to appropriate comfort standard Advanced localized controls</p>	 <p><b>FILTRATION: DUST &amp; PESTS</b></p> <p>Filter air at MERV 13 or higher Implement advanced purification solutions</p>
 <p><b>MOISTURE</b></p> <p>Control to 40%-60% relative humidity</p>	 <p><b>SAFETY &amp; SECURITY</b></p> <p>Implement touchless access Execute advanced access solutions</p>	 <p><b>NOISE</b></p> <p>Design for minimum equipment background noise</p>	

## Carrier’s Approach to Healthy Buildings

### ASSESSMENTS

Many building owners and operators may be unsure about how to move forward in developing a healthy building strategy. That’s why, through our best-in-class BluEdge service offering, Carrier is here to help – starting with assessments across all aspects of your building.

### OPTIMIZATION

Through advanced controls and digital solutions and services, Carrier is here to help you confidently optimize your building – and the investment in creating a healthy, safe environment.



### IMPLEMENTATION

Healthy buildings must strive to meet a number of foundational criteria, which cover everything from ventilation and air quality to lighting, views and physical security. Carrier has built a complete portfolio of solutions to address these criteria, with a full range of HVAC solutions and controls and fire and security solutions covering everything from fire detection and prevention to thermal screening and touchless access.

### EXPERTISE

Carrier has a history of expertise in healthy buildings. We invented modern air conditioning and helped establish the first NICU - and one of the earliest examples of a healthy indoor environment - at Allegheny General Hospital in 1914. We drove the green building movement and we invigorated the dialogue around the impact of indoor environments on people, performance and health with the groundbreaking COGfx and HEALTHfx studies. Today, we continue to apply more than 100 years of experience creating optimal indoor environments, partnering with academic researchers and global experts to unlock the incredible potential of indoor environments.

### CONTACT YOUR LOCAL CARRIER EXPERT

to learn more about the solutions and services that will help improve the air quality, ventilation, and overall health in your buildings.





# ADVANTEC

**Our AdvanTEC experts work with customers to design, develop and deliver innovative building solutions to make buildings more sustainable, more healthy, more intelligent and with an improved user experience.**

Our global AdvanTEC team provides consultations and solution designs to help enterprises solve their most complex building problems with a holistic approach through different personas needs, usage modes and building subsystems. The challenges of the post-pandemic world and the ambitious ESG goals, that most of our customers are setting up to improve our lives and our planet, require multidisciplinary skills and innovative integrated solutions.

Smart, sustainable and healthy buildings design needs to match decarbonization targets, indoor air quality, improved security, complex and new usage modes (flex working), value added digital services based on IoT and AI (predictive maintenance, analytics): AdvanTEC, working directly with customers, with structured assessment methodologies and industry-leading modelling tools, co-design and develop the best solutions for the specific application and needs, leveraging on the comprehensive portfolio of Carrier.



**01** Market capabilities

**02** Project identification

**03** Custom solution definition

**04** Engineer and develop solution

**05** Deliver solution

# HEALTHY, SAFE, SUSTAINABLE AND INTELLIGENT

We have had to face critical challenges in the way we interact with the built environment during the last few years with COVID-19 and we will do so in the coming years, climate change is advancing, and we need to act. At Carrier, we're building on decades of leadership in sustainability, healthy and intelligent buildings to set ever-higher standards. We're committed to changing the way buildings are designed, built, and operated to suit the way we live and work today and into the future.

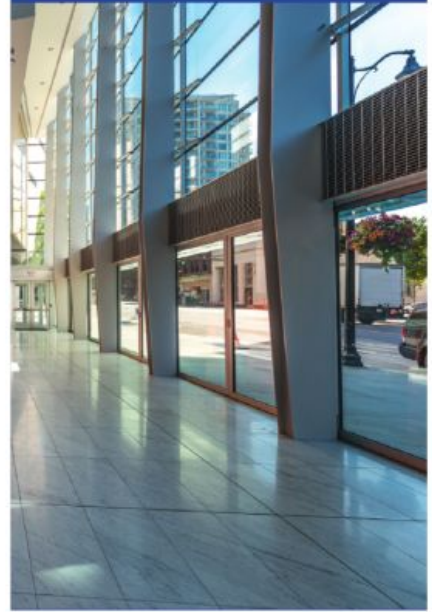

## **Sustainable buildings: Supporting customers in the drive for net zero by 2050**

Looking to contain the rise in global temperatures, organisations around the world are recognising the need to reduce the energy they consume and use less harmful solutions to cool and heat their properties. At Carrier, we're uniquely positioned to help our customers to achieve their goals using high efficiency chillers, exceptional service and maintenance programs, bespoke customer solutions and better refrigerant choices with a low Global Warming Potential (GWP).



## **Healthy buildings: Making buildings healthy, safe and secure**

Decades of leadership in sustainability have guided Carrier to the forefront of the healthy buildings movement. The COVID-19 pandemic presented significant challenges for the owners and operators of commercial buildings, initially to protect occupants and enable the safe reopening of businesses. Moving forward, our healthy building strategies are focusing on design, retrofit and operation, effectively transforming the workplace into a powerful tool to drive human health and progress.



## **Intelligent Buildings: Ensuring buildings are ready for the new ways of working**

Our vision is to create solutions that make a positive impact on people and on our planet, underscoring the importance of the work we do as the world leader in healthy, safe, sustainable, and intelligent building systems. We optimise built environments to improve operational efficiency and impact positively on the occupants, from helping to ensure physical safety and security to improving health, productivity, and cognitive performance.

**We employ a lifecycle approach to our work using an industry-leading portfolio of advanced equipment, services and automation offerings covering HVAC and Fire & Security to support our customers in achieving their goals.**



# DATA CENTER

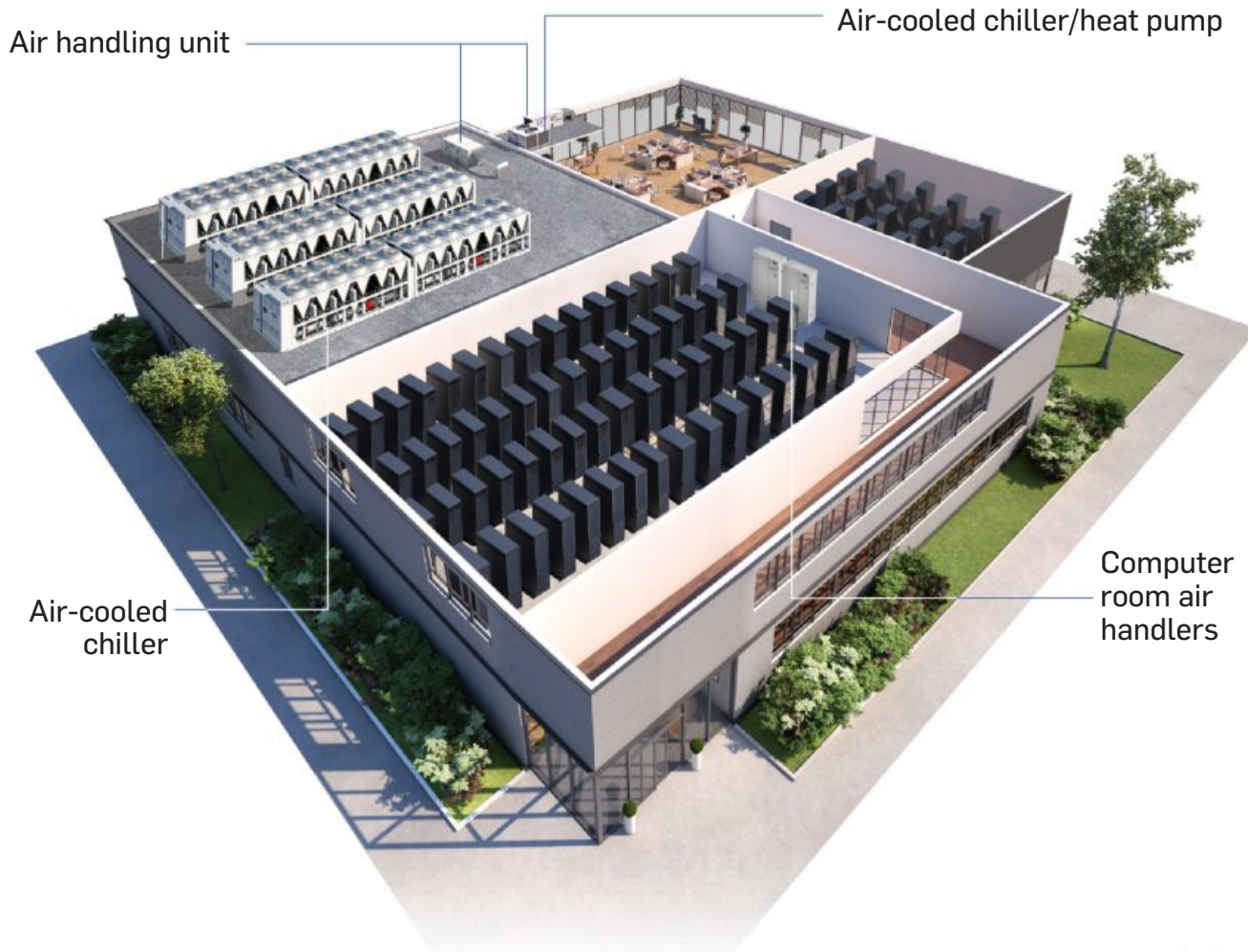

## KEY ADVANTAGES

### Fast capacity recovery

Maximum uptime is a priority for data center applications. To meet this challenge, the IT cooling system must be reliable and able to respond to unexpected variations. Carrier developed its dedicated fast capacity recovery feature, offering significant reduction of recovery time in case of power failure.

### Reliability

Products undergo extensive tests before they are shipped to the customer and are also certified by internal organisations to ensure the highest levels of safety and quality.

### Total free cooling

Air- or water-based free cooling systems are popular for data center applications

where the climate is suitable, resulting in energy savings through reduced use of the number of compressor running hours during the cold season. Carrier offers airside free cooling options on air handling units and hydraulic free cooling options for chiller systems, either with Carrier patented DX free cooling integrated system or using non-integrated systems using dry coolers or towers.

### Smart energy management

Advanced control solutions such as Carrier PlantCTRL™ allow facility managers to control the HVAC system and to optimize it as a whole for maximum availability and minimized energy consumption.

### PUE optimized



# INDUSTRY

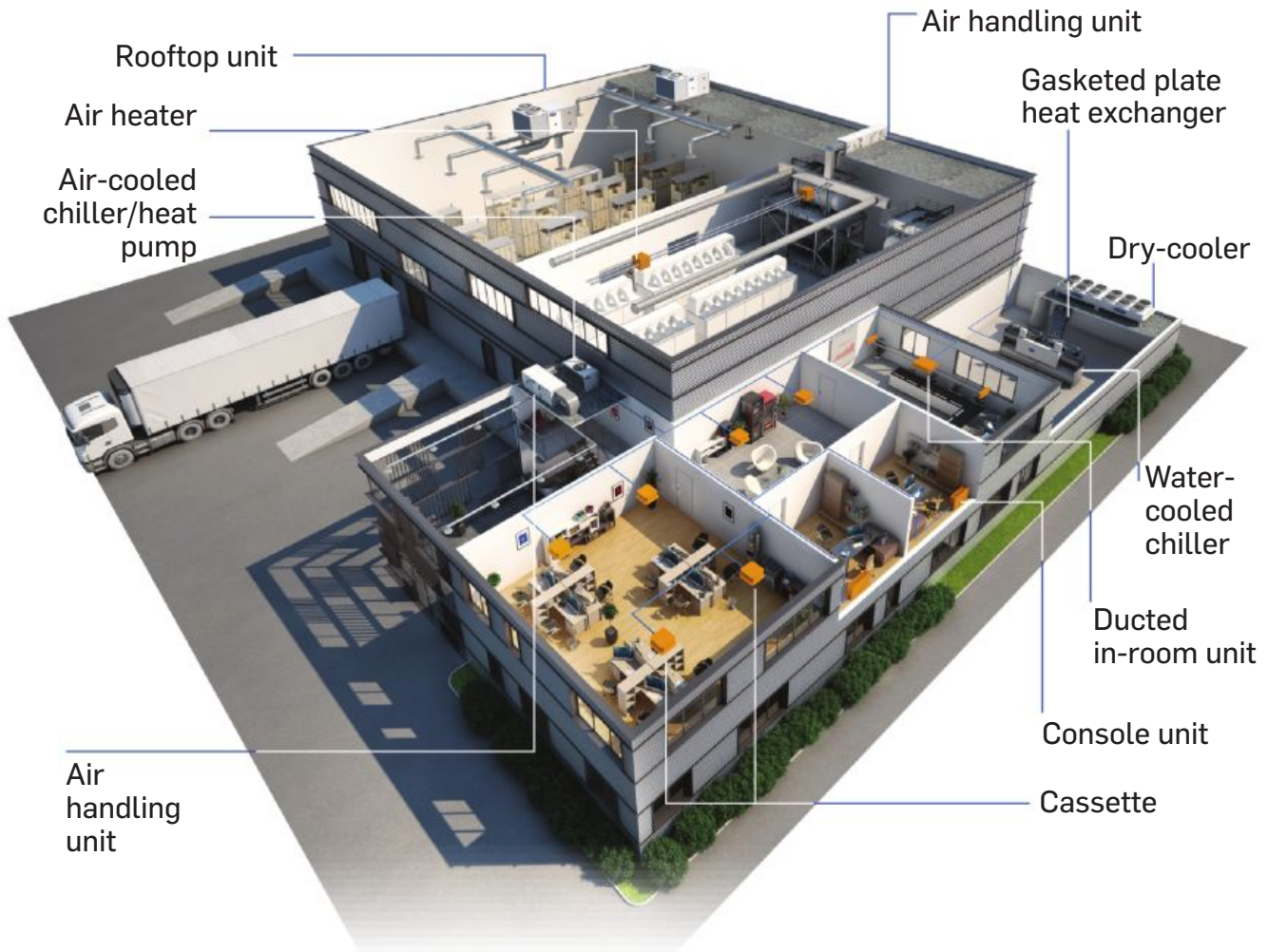

## KEY ADVANTAGES

### Chilled water production down to -15°C

Low temperature chilled water production down to -6°C (medium) or to -15°C (low) covers specific applications such as ice storage and industrial process cooling.

### High efficiency at full and partial load

An inverter-driven machine usually offered very high

efficiency at partial load, but achieving high efficiency at partial load often means sacrificing efficiency at full load. Thanks to AquaForce® with Greenspeed® intelligence, you can have both.

### Proximity and proactivity to ensure no downtime

Advanced monitoring service offering continuously collects information from equipment to anticipate and prevent loss of

performances or any damage. This solution enables users to track and monitor their HVAC system performance and to take preventive and corrective actions remotely, optimizing the lifetime of the equipment.

### Smart energy management

Advanced control solutions such as Carrier® PlantCTRL™ allow to control the HVAC system and to optimize it as a whole for maximum

availability and minimized energy consumption.

In addition, Carrier designs, engineers and implements custom-made Thermal Energy Storage (TES) solutions for HVAC systems with peak cooling demand > 500 kW.

100% smart grid compatible, the TES solution reduces the capacity of the chillers by 30% to 70%, secures the cooling production and optimizes occupants' comfort.



# SMART HEATING

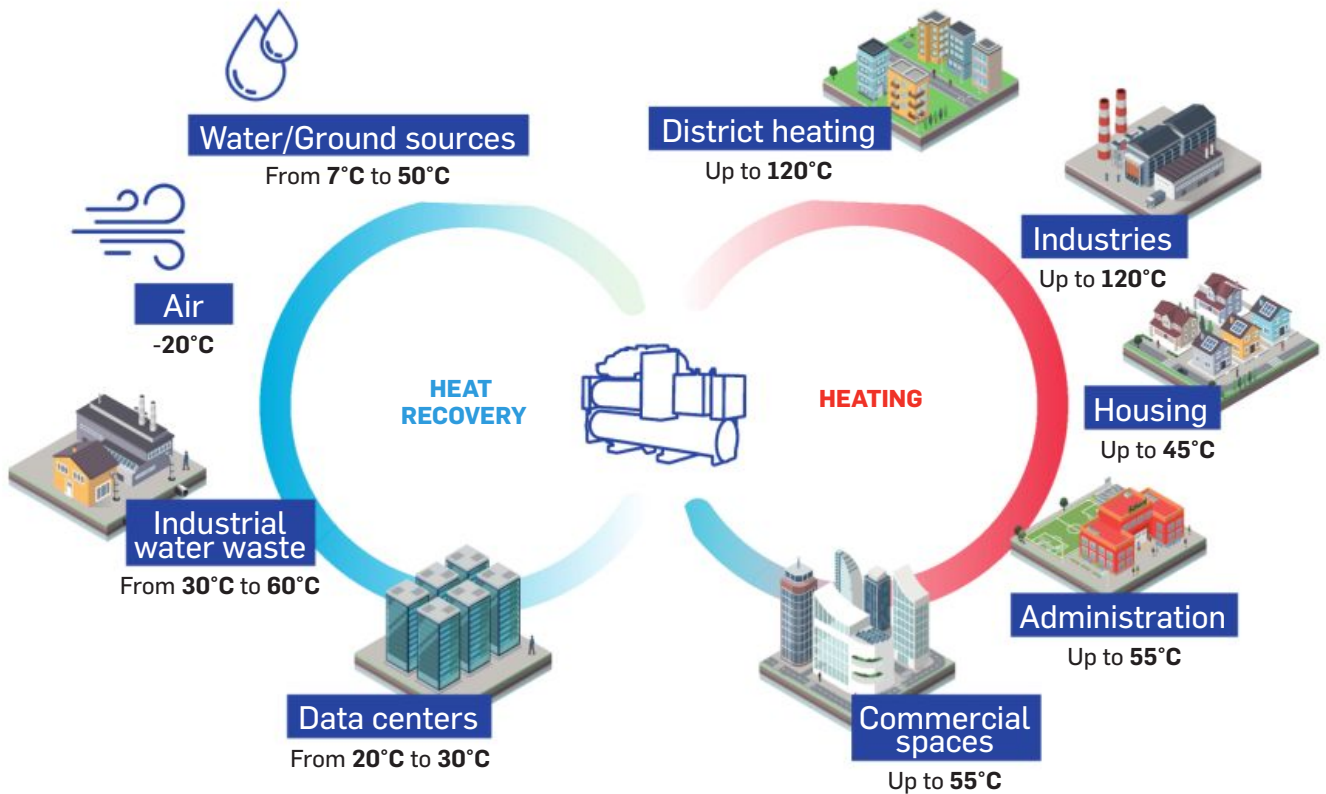

## KEY ADVANTAGES

### Heat-pump, a renewable energy

The REPowerEU initiative considers increasing smart heating and cooling networks to 30% by 2030 and to 50% by 2050 as essential milestones in achieving the ambitious goals of decarbonization. Carrier is facing this challenge head on with solutions dedicated to district heating applications, such as the 61XWHZE range. Carrier heat pumps are part of the environmentally sustainable technologies

using renewable energy quoted in the European Directives on the use of Renewable Energy (RES). The Directive recognizes the technology as using renewable energy sources from air, water and ground.

### Heat-pumps do not depend on fossil fuel price rises

Future fossil fuel supply is determined by the resources in the ground and the technology available for extraction. Prices are

assumed to rise as fossil fuels are depleted, requiring more expensive technology for extraction.

### No noise & gas pollution compared with biomass boilers

Carrier heat-pumps are supplied by electricity, are relatively quiet and do not exhaust gas. Installation of biomass boilers may impact the inhabitants and expose them to noise pollution and remove emissions that may cause coughing and sore

throats. In addition, delivery vehicles are needed to deliver the fuel and haul away ashes.

### Eligible to financial incentives

Many government environmental programs provides financial incentives for heat-pumps to support renewable heat production: Fonds Chaleur, Certificats d'Economie d'Énergie (CEE) in France, Non-Domestic Renewable Heat Incentive (RHI) in the UK.



# RESIDENTIAL DEVELOPMENT

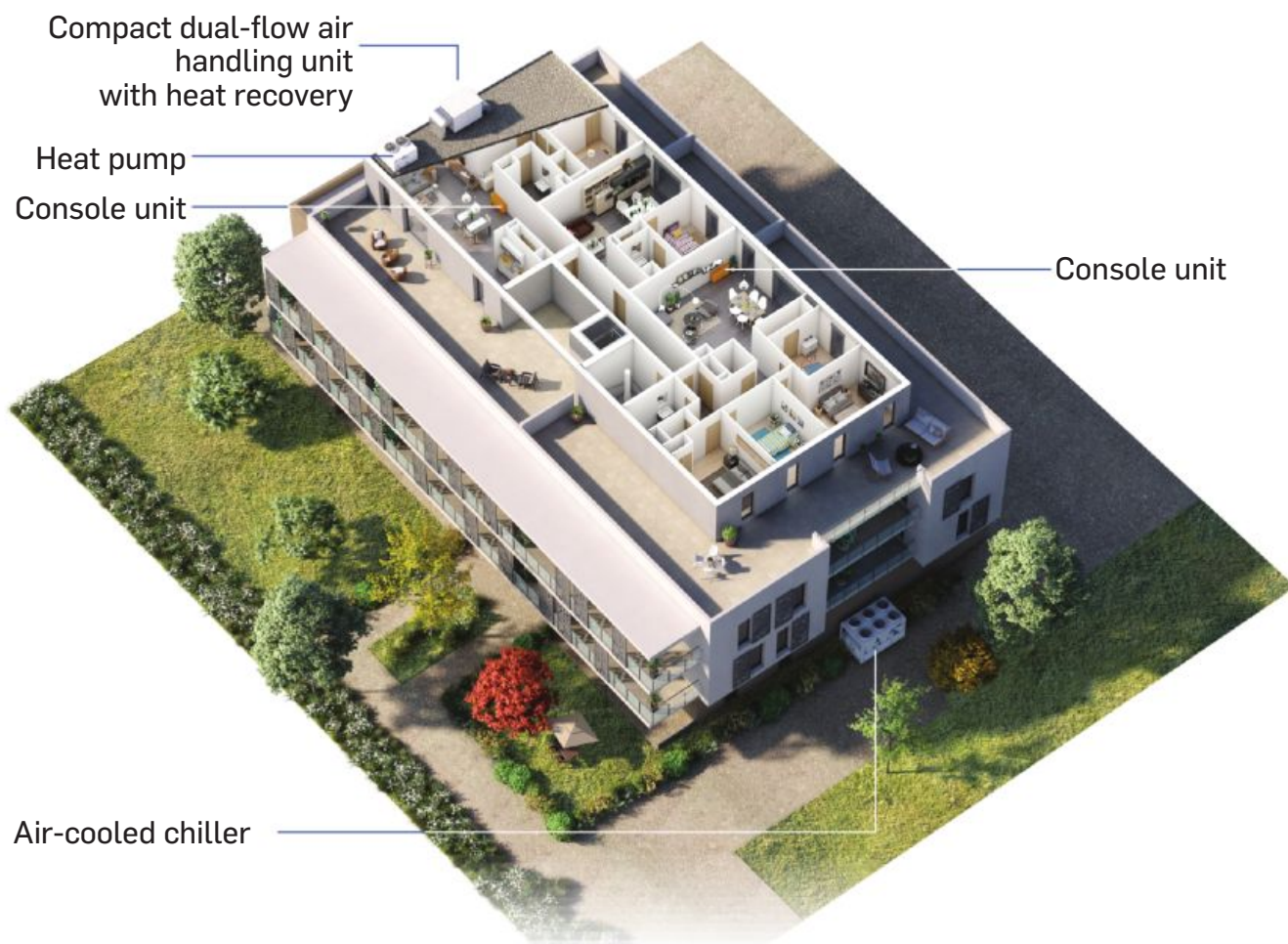

## KEY ADVANTAGES

### Indoor air quality

Carrier solutions can help to ensure and maintain a controlled microclimate, regulating the temperature and humidity levels, as well as ensuring optimal indoor air quality.

### Large range of heat pumps

Carrier has introduced dedicated heat pumps designed for heating

applications. They deliver superior energy efficiency both during cooling and heating operation whatever the external weather conditions: from  $-20$  to  $46^{\circ}\text{C}$  outdoor air temperature.

### Energy savings

With a Seasonal Coefficient of Performance (SCOP) up to 4.7, AquaSnap 30AWH is the best value for air conditioning and heating solution in light commercial applications: the Heating Optimized

technologies improve significantly the heating capacity at low temperature, while the EnergySoft innovative defrosting technology improve the energy efficiency.

### Plug and play compact solutions

With complete factory wiring, easy handling features, factory-installed options and intuitive interface, the AquaSnap 30AWH and 30RQV set up is fast and

straightforward. Their compact size allows easy integration for small offices and shops.

### Advanced control

The new generation of control, NHC, perfectly meets the thermal needs of commercial buildings while insuring the Energy efficiency optimisation. NHC integrates master-slave configuration up to 4 units, with JBUS connection.





# OFFICE

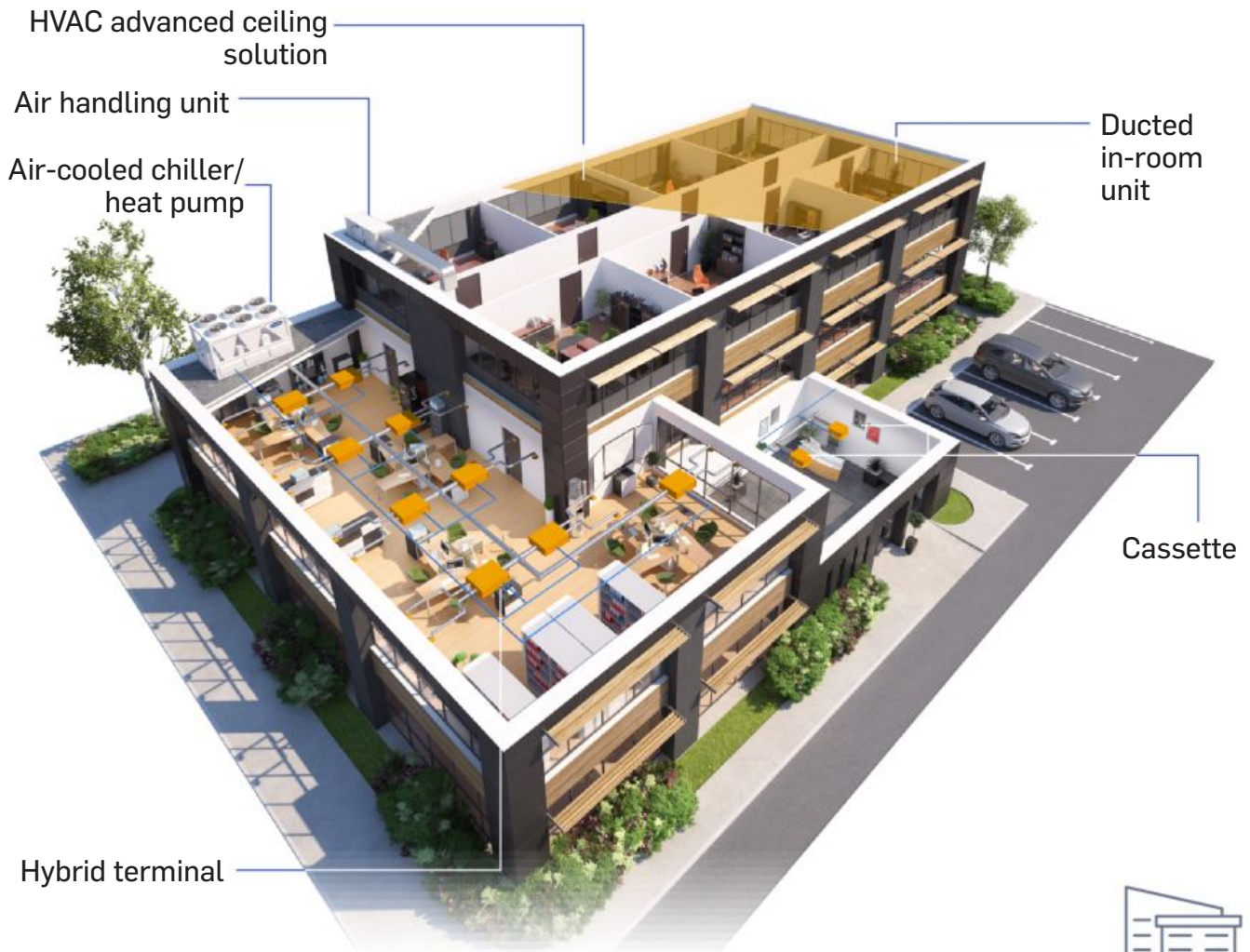

## KEY ADVANTAGES

### Environmentally sustainable building approach

Carrier solutions not only offer efficiency to reduce the overall building energy consumption but are also designed for easy system integration: variable-speed pumps for efficient operation, time-scheduling, double-set-point; night-mode operation to optimize the chiller operation according to the requirements of the building; several communication protocols and remote monitoring to secure

consistent efficiency through the entire lifetime of the equipment.

### Partial free cooling

For applications with moderate cooling demand throughout the entire year including the cold season, units can be equipped with a patented Carrier DX free cooling system with a dedicated pump by-passing the compressor on one or both refrigerant circuits during winter operation. Operating without glycol, no extra free cooling coil. This results in

significant energy savings.

### HVAC advanced ceiling

The HVAC advanced ceiling, in association with a Carrier ducted fan coil combines the advantages of radiation and convection to provide a high-level of comfort. In association with the high responsiveness and excellent capacities of the ducted fan coils, the solution guarantees energy efficiency, high level of comfort, extremely low noise, high indoor air quality and total customization of the

ceiling with printing, light or sound integration.

### Comfort management

From open space to individual offices, comfort can be personalized and controlled according to occupancy. The Aquasmart® system manages building zoning, occupancy and room temperature in accordance with needs. The system offers a remote access (WebCTRL®) and records historical data of the HVAC equipment.

# HEALTHCARE

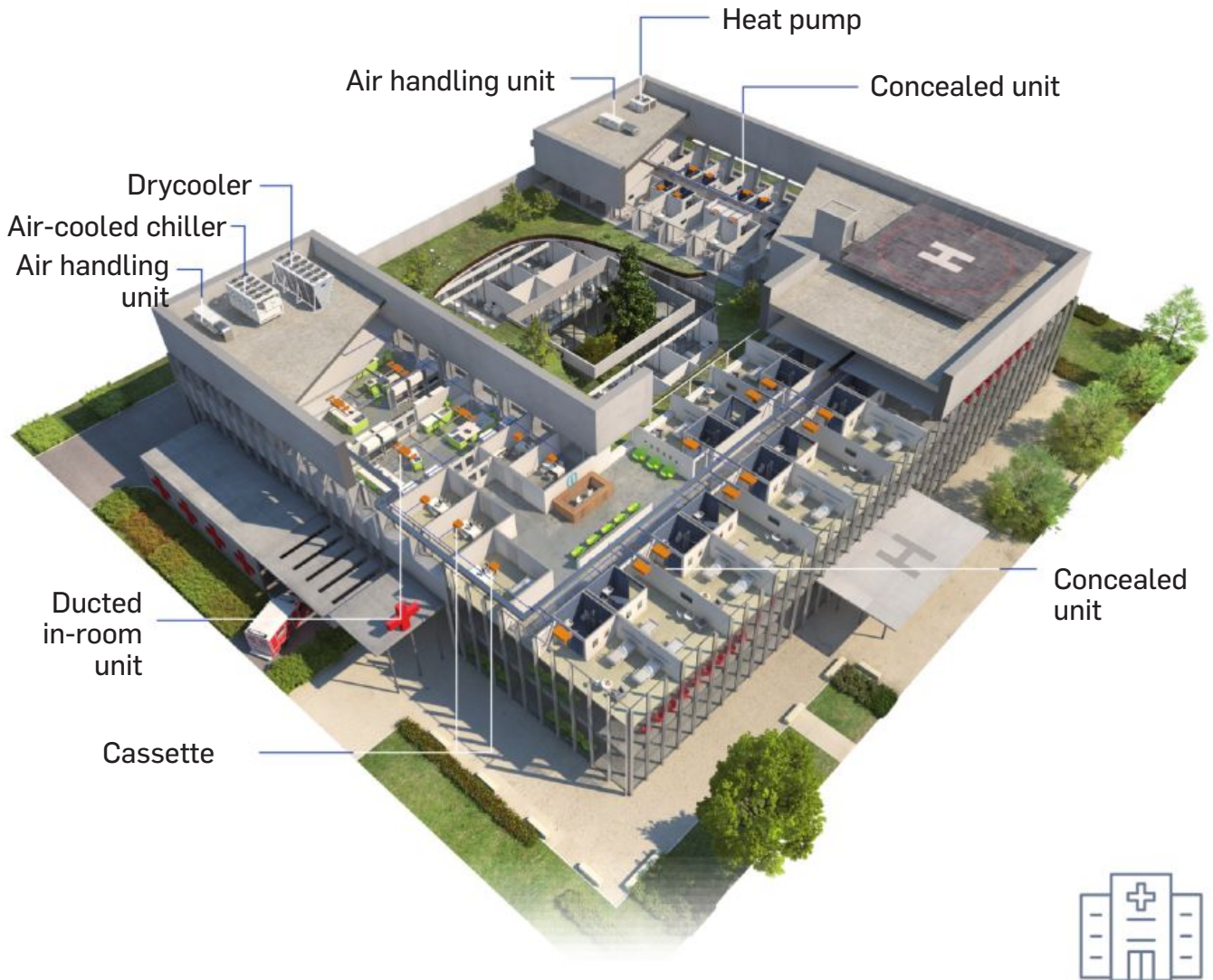

## KEY ADVANTAGES

### Air quality

Carrier solutions can help to ensure and maintain a highly controlled microclimate, regulating the temperature and humidity levels, as well as ensuring optimal indoor air quality (filtration efficiency levels, management of CO<sub>2</sub> levels).

### Free cooling

For healthcare applications with 24/7 operations, a cooling demand may exist throughout the entire year. Units equipped

with a patented Carrier DX free cooling can offer significant energy savings without need for the use of glycol or extra free cooling coils and controls.

### Heat recovery

Carrier offers a range of heat recovery options, including high efficiency heat recovery on air handling units and desuperheaters or heat recovery condensers on chiller systems to contribute to reduced heating energy usage.

### System control

Hospitals often have dedicated control rooms to monitor the proper operation of all equipment in the entire building. Thanks to the availability of open protocol communication interfaces, Carrier equipment can be easily integrated in the building management system on site and, thanks to Carrier® PlantCTRL™, owners and plant managers may benefit from optimized control of the HVAC system plant room to reduce

energy consumption and ensure continued delivery of comfort and air quality.

In addition, Carrier designs, engineers and implements custom-made Thermal Energy Storage (TES) solutions for HVAC systems with peak cooling demand > 500 kW. 100% smart grid compatible, the TES solution reduces the capacity of the chillers by 30% to 70%, secures the cooling production and optimizes occupants' comfort.





# EDUCATION

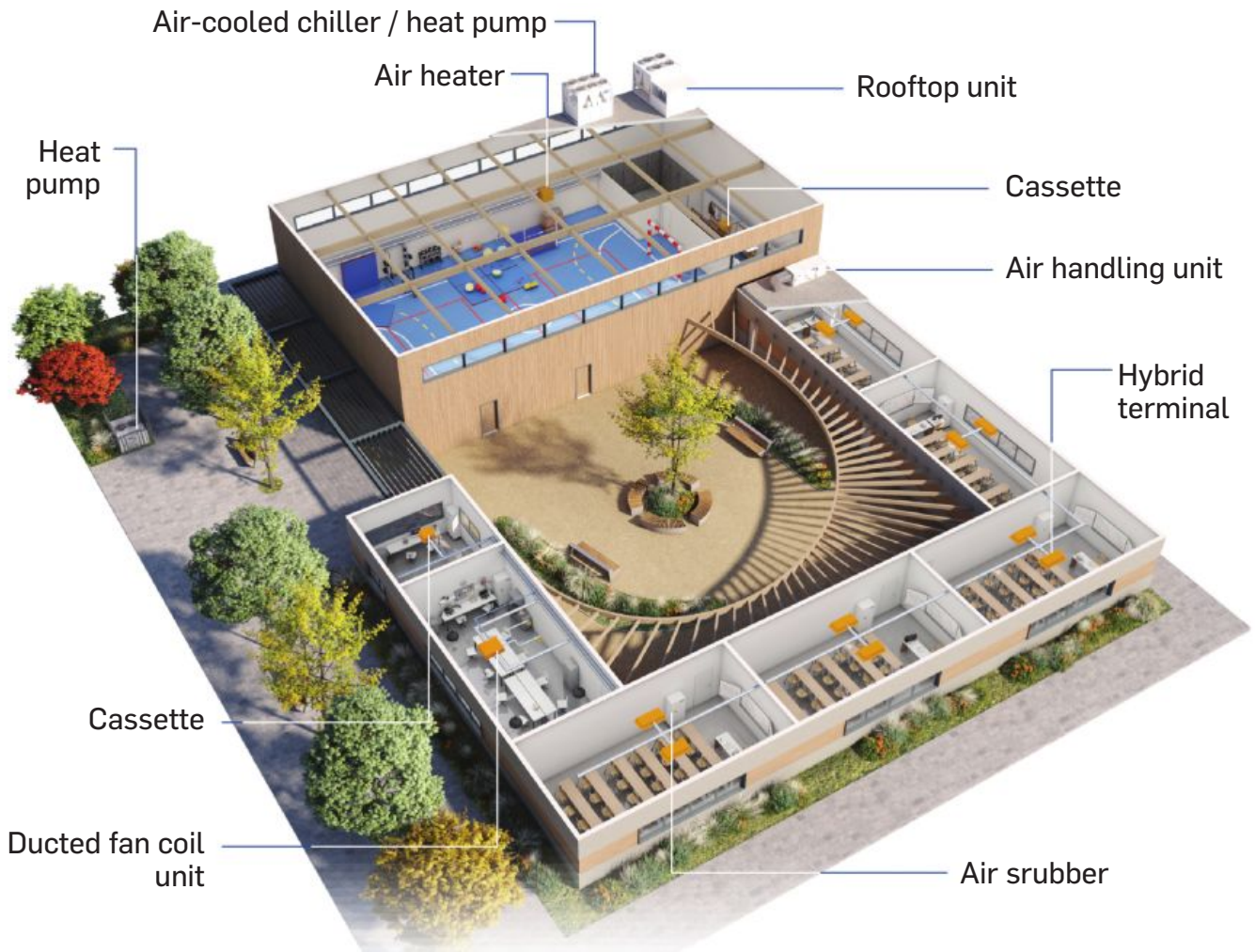

## KEY ADVANTAGES

### Indoor air quality

The health and safety of indoor environments can be significantly improved with consistent service and maintenance of not only buildings themselves, but also most importantly HVAC systems. The ventilation, heating and air conditioning solutions reliably reduce the concentration of indoor contaminants by introducing filtered outdoor air into the

building. On a very effective way, this process is also made easy thanks to specific air scrubber units.

### Building Upgrade

As the inventors of modern air conditioning and a world leader in HVAC, refrigeration, and fire and security solutions, Carrier has a legacy of creating safe and comfortable buildings. Retro. fits, modernizations and

upgrades must be done with student health and safety as a top priority, while being smart about costs, budgets and future requirements. Our experts are here to help – starting with assessments across various aspects of a building.

### Plug and Play solutions

The design of the equipment is made to simplify your

installation as much as possible, making it easier to use for this application.

### Enhance University reputation

Strengthen university brand equity and loyalty by creating a distinctive educational and campus environment with personalized control.



# HOSPITALITY



## KEY ADVANTAGES

### Low noise features

Air conditioning, ventilation and heating (depending on the region and season) are among the first things guests experience. Carrier terminal solutions and diffusion capabilities offer the low noise performance that guests require in a relaxing environment.

### 36XH Hybrid Terminal

The 36XH Hybrid Terminal combines the advantages of both chilled beams and fan coils: energy efficiency, high level of comfort, extremely low noise and high level of air indoor quality. The fresh air intake volume can be

controlled according to CO<sub>2</sub> levels in order to provide the best indoor air quality and comfort in hotel rooms and minimize the global energy consumption of the system. The 36XH has three operation modes:

- Night mode: based on induced fresh air only
- Day mode: based on the combination of induced fresh air and water coil operation
- Boost mode: based on the combination of induced fresh air, water coil operation and fan operation

### Advanced temperature controls

Personalising a guest's stay is vital to building a relationship that will keep

them coming back. Carrier's easy-to-use, aesthetically pleasing user interfaces supported by energy management systems, from Aquasmart® to WebCTRL®, make providing individualized climate settings cost effective and intuitive. User interfaces are available in a wide variety of options in Carrier's range.

### Heat recovery

Carrier offers a range of heat recovery options, including high efficiency heat recovery on air handling units and desuperheaters or heat recovery condensers on chiller systems to contribute to reduced heating energy usage.

### Sanitary hot water

Hotels require a constant supply of sanitary hot water for various areas. Heat recovery at very high temperature is possible for many Carrier chillers offering energy to pre-heat the hot storage tank normally heated by traditional boilers. Furthermore dedicated high temperature heat pumps capable of hot water production up to 68°C offer further opportunities to reduce energy consumption of the system.



# RETAIL

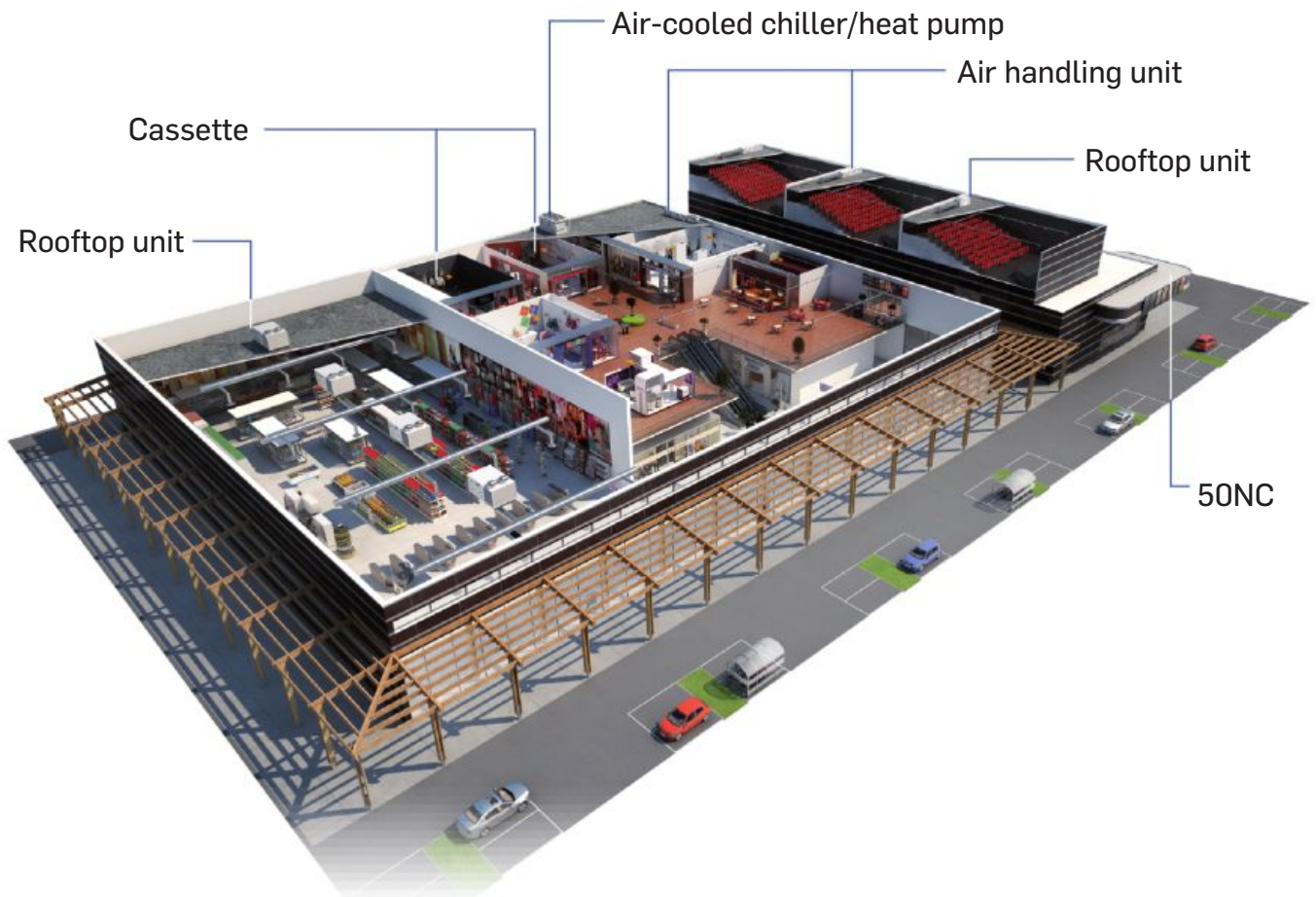

## KEY ADVANTAGES

### For small/medium individual needs

Cost-effective self-contained air conditioning solutions for retail applications and/or warehouses are rooftop units. Designed for outside installation, these systems provide an easy, versatile solution for both new and retrofitted buildings. A range of types and options provide cooling, heating and ventilation and allow a variety of system designs from constant volume to variable volume designs.

### For larger centers

Centralized chiller systems and air handling units distribute chilled water and treated ventilation air to the shopping complex. Individual shops select the most appropriate chilled water terminals or packaged air treatment solutions for their comfort needs and to suit interior design.

### Heat recovery

Carrier offers a range of heat recovery options, including high efficiency heat recovery

solutions on rooftop and air handling units. These can contribute to reduced heating energy usage or in some cases replace components that use alternative fuels.

### Indoor air quality

Carrier solutions can help to ensure and maintain a highly controlled microclimate, regulating the temperature and humidity levels, as well as ensuring optimal indoor air quality (filtration efficiency levels, CO<sub>2</sub> levels management).

### Climate control systems

Carrier designs, engineers and implements custom-made Thermal Energy Storage (TES) solutions for HVAC systems with peak cooling demand > 500 kW.

100% smart grid compatible, the TES solution reduces the capacity of the chillers by 30% to 70%, secures the cooling production and optimizes occupants' comfort.



# LOGISTICS

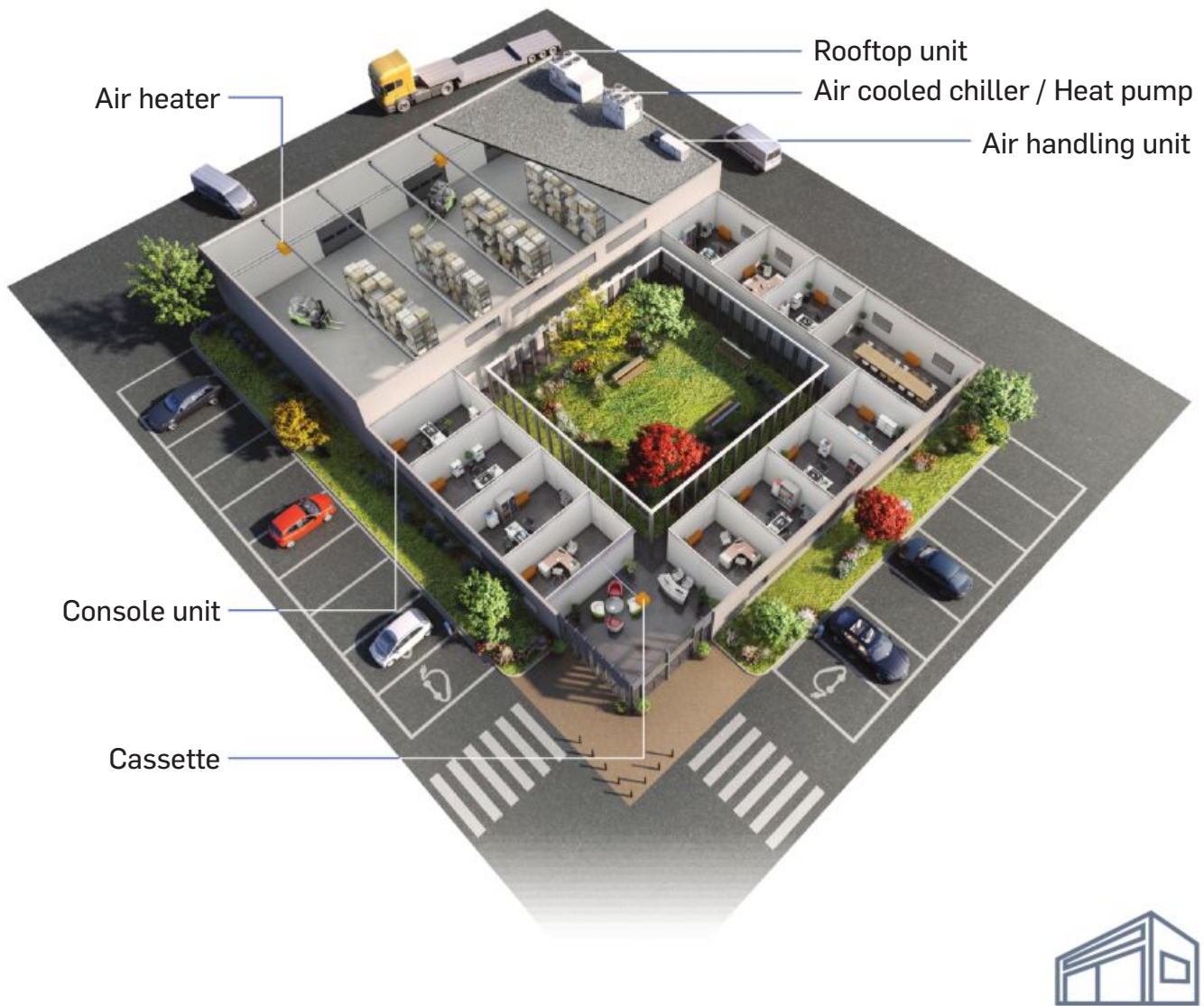

## KEY ADVANTAGES

### Control and manage individual temperature

Cost-effective self-contained Carrier technologies are equipped with a multi-zone control system that helps logistics buildings to automatically adapt the temperature in the different rooms (offices, warehouse, reception), based on different factors such as human traffic, heating and ventilation and allow a variety of system designs from constant volume to variable volume designs.

### For larger comfort

Centralized chiller systems Carrier is responsible for ensuring the best possible comfort for occupants, regardless of the number of shops select the most appropriate chilled water terminals or packaged air treatment solutions for their needs and to suit the building.

Carrier offers a range of heat recovery options, including high efficiency heat recovery

### Energy savings

Carrier is committed to saving as much energy as possible, Carrier has developed solutions that allow for high environmental responsibility while maintaining high seasonal performance. One of these solutions is our rooftop highly efficient air conditioning units that reduce energy consumption to a minimum, as ensuring optimal indoor air quality (filtration efficiency levels, CO<sub>2</sub> levels management).

### Environmentally sustainable

Carrier is committed to limiting the environmental impact of its products and solutions in line with HVAC industry challenges by lowering refrigerant GWP and increasing the HVAC system efficiency. The TES solution reduces the capacity of the chillers by 30% to 70%, secures the cooling production and optimizes occupants' comfort.





# CULTURAL HERITAGE

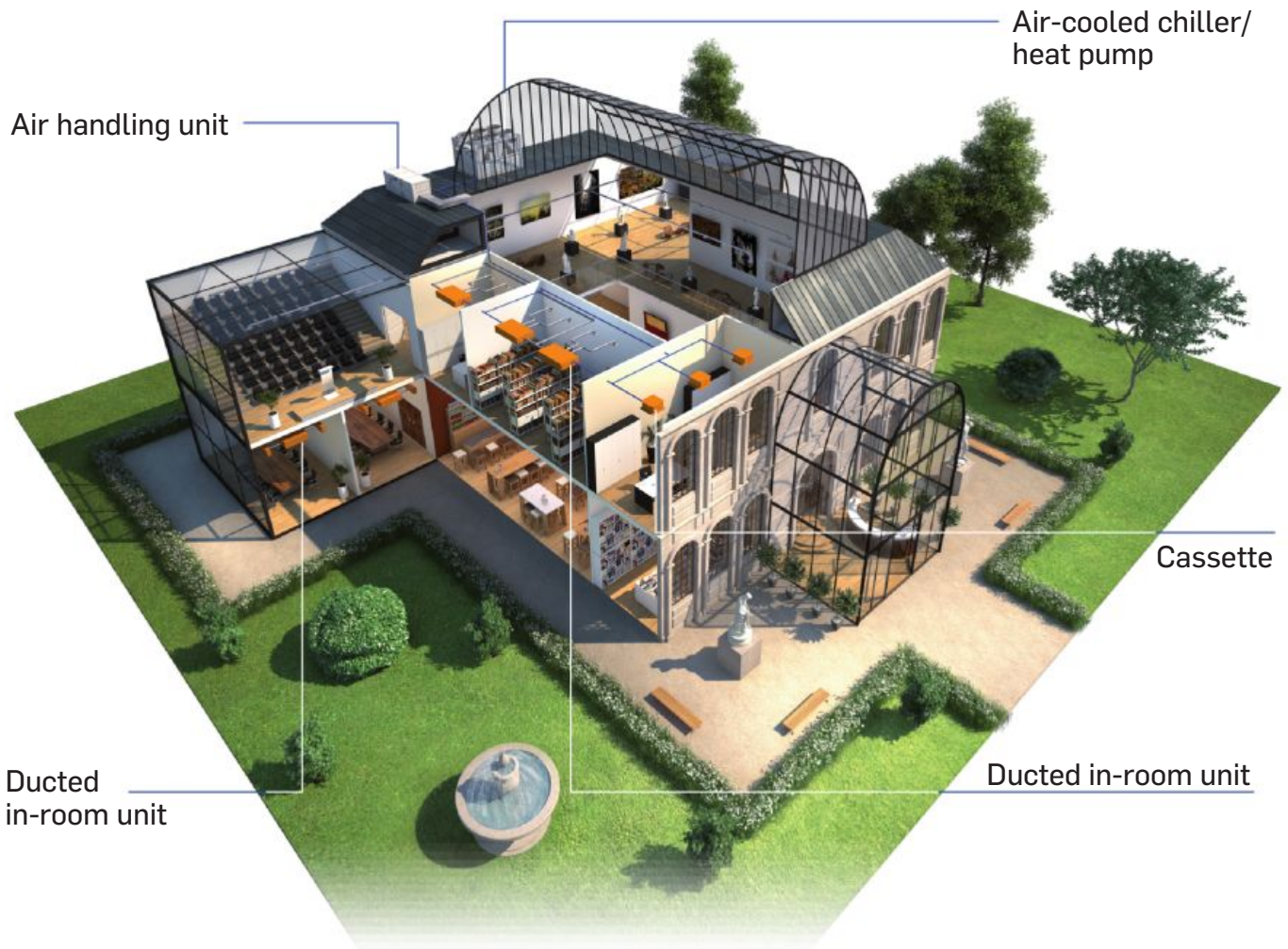

## KEY ADVANTAGES

### Low noise emission

Carrier units have dedicated low noise options to be virtually unnoticeable and to respect the need for "church-quiet" noise levels.

### Precise adaptability to load variation

Conditions inside buildings change as a result of many factors including the local climate, the time of the day and the number of visitors. Carrier solutions equipped with

precise electronic capacity controls and variable-speed motors adapt to meet load variations in just a few seconds, assuring exceptional comfort and in turn ensuring minimum energy consumption.

### Indoor air quality

Carrier solutions can help to ensure and maintain a highly controlled microclimate necessary to protect the works of art, regulating the temperature and humidity levels, as well as ensuring

optimal airflow quality and velocity.

### Smart energy management

Night-mode operation, time-scheduling and precise room temperature control are key features for any cooling or heating device operating in a museum. Thanks to advanced control systems such as Aquasmart® and Carrier® PlantCTRL™, the HVAC system can be controlled and optimized as a whole for

maximum comfort and minimized energy consumption.

In addition, Carrier designs, engineers and implements custom-made Thermal Energy Storage (TES) solutions for HVAC systems with peak cooling demand > 500 kW. 100% smart grid compatible, the TES solution reduces the capacity of the chillers by 30% to 70%, secures the cooling production and optimizes occupants' comfort.

# MARINE & OFFSHORE

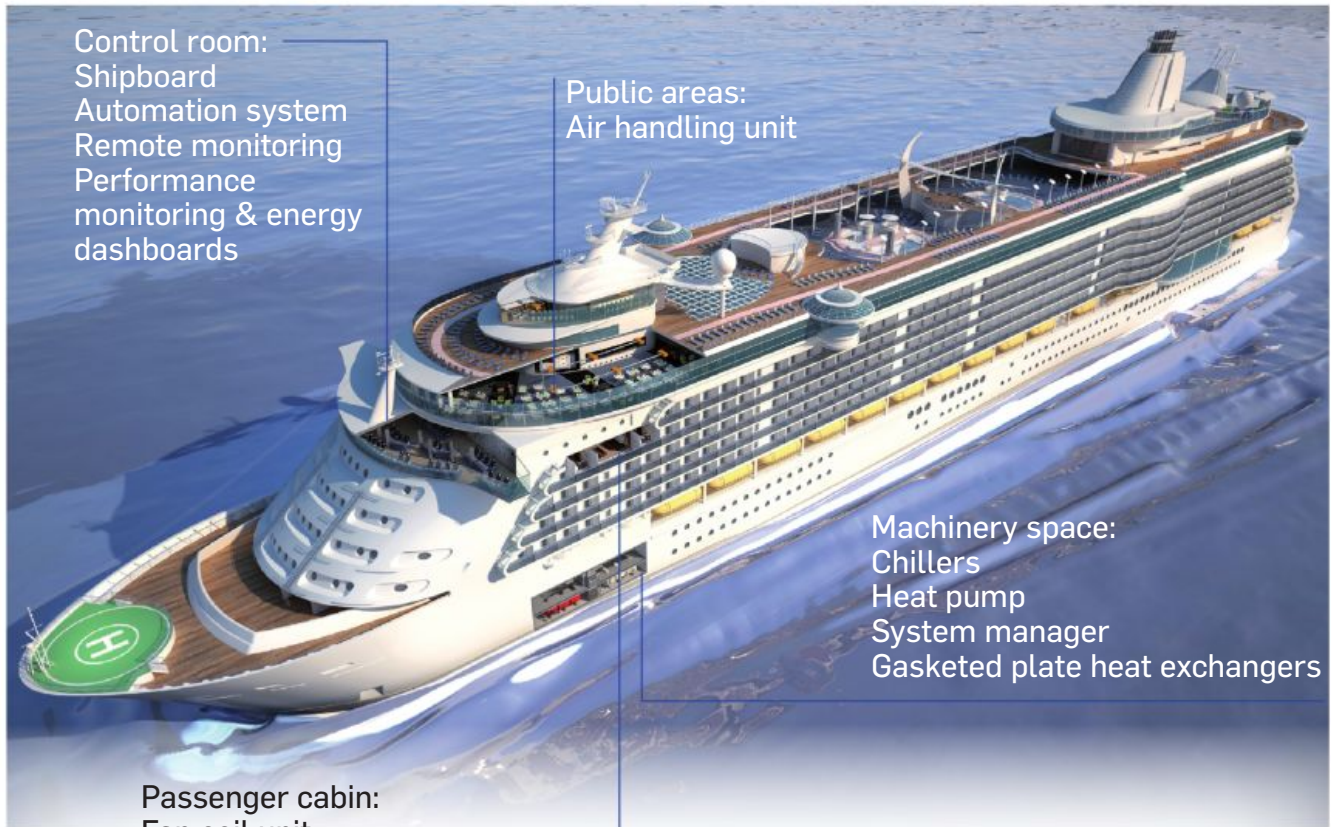

**Control room:**  
 Shipboard  
 Automation system  
 Remote monitoring  
 Performance  
 monitoring & energy  
 dashboards

**Public areas:**  
 Air handling unit

**Machinery space:**  
 Chillers  
 Heat pump  
 System manager  
 Gasketed plate heat exchangers

**Passenger cabin:**  
 Fan coil unit  
 CO<sub>2</sub> sensor with active  
 ventilation  
 Lights and blinds module



## KEY ADVANTAGES

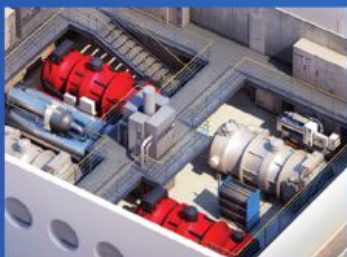

### Machinery space

- HFO Refrigerants
- AquaEdge™ two-stage chillers
- AquaForce® 30XWHV water-to-water heat pump
- PlantCTRL™ system manager
- 10TE gasketed plate heat exchangers



### Passenger cabin

- 42MS passenger cabin fan coil
- 36XH hybrid terminal
- WTC controller
- Room controller
- CO<sub>2</sub> sensor with active ventilation
- Lights and blinds module



### Public areas

- 39CQ compact air handling unit
- 39HQ AiroVision air handling unit
- 39CZ AiroVision air handling unit





# YOUR SERVICE PARTNER



Your daily challenge is a complex balance between maintaining optimal comfort levels, maximising system uptimes and minimising cost of ownership. BluEdge service teams are committed to ensuring your peace of mind and supporting your business objectives throughout the lifecycle of your equipment. We can help you create a customized program that is suited to your specific goals and needs.

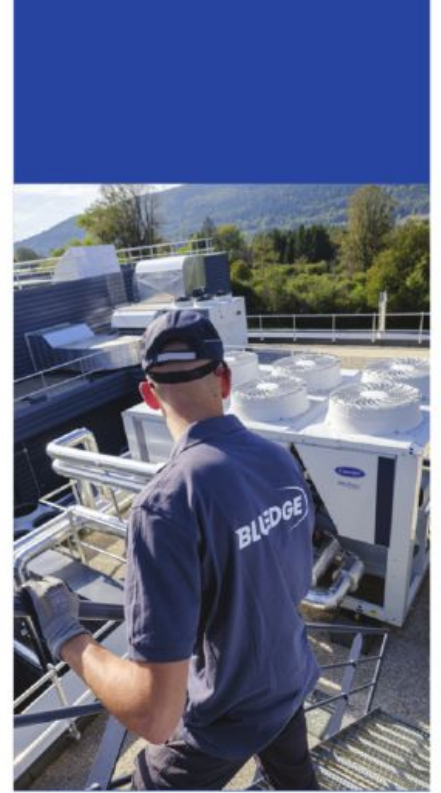

## Customer needs come first

### Proximity & Responsiveness

BluEdge service expert technicians are there to take action, quickly. Comprehensive and highly efficient maintenance processes mean your equipment works at peak performance level.

If necessary, you can rely on Carrier Rental Systems and readily available spare parts to avoid extended downtime.

### Expertise & Consultancy

The BluEdge service platform has experienced teams, an extensive network of branches, top grade logistics and powerful information systems. These industry-leading resources come together to deliver a best-in-class service.

Your BluEdge service experts will help you to find the right balance between enhancing energy efficiency and maximising your investments.

### Proactivity

As your preferred partner, Carrier designs tailored maintenance programs to meet your goals and optimize your business performance.

## Worldwide-recognized experts

### Asset Management

- Advise on fast-moving regulatory environment.
- Guidance for energy optimization solution.
- Information on EH&S guidance.
- Providing educational sessions.

### Technical expertise

BluEdge service technicians benefit from a multifaceted training program based on 115 years of industry experience to bring you top level, up-to-date service.

- Technical training to ensure the teams remain familiar with all equipment types.
- Environmental, Health and Safety (EH&S) training to ensure the highest standards of ongoing safety.

Present  
in more than  
**60**  
countries

**24/7**  
on-site  
availability

More than  
**115**  
years  
of experience



# A COMPREHENSIVE SERVICE RANGE TO BEST FIT CUSTOMER NEEDS



## MAINTENANCE

- **Reduced, tightly controlled running costs**
- **Maximized equipment lifetime**
- **Full F-gas compliance for chillers**

Carrier offers a comprehensive range of service agreements for all brands of chillers, rooftops, split and VRF (Variable Refrigerant Flow) air conditioning, air handling units, controls and accessories, from preventive to predictive maintenance.



## REPAIR

- **Minimized downtime and losses**
- **Increased occupant satisfaction**
- **Emergency Repair Kits available on site**

Carrier's factory-trained technicians fix your systems expertly and efficiently. For quick and easy repairs, Carrier designed repairs kit solutions. All around Europe, our customers benefit from a dense network of experts to get the efficient support for all application and business needs.



## SPARE PARTS

- **State-of-the-art logistics with reliable next day deliveries**
- **Facilitated parts selection, and order on line:**

[www.store.carrier.com](http://www.store.carrier.com)

- **Comprehensive parts solutions for all equipment**

Carrier's powerful supply chain provides you with genuine manufacture parts and consumables with high service levels. The dedicated expert team facilitates your selection.



## MODERNISATION

- **Compliance with new regulations**
- **Refrigerant conversion for chillers**
- **Improved reliability and optimized performance**

Carrier experts support you all along the lifecycle of your building, HVAC plant and equipment. We propose turnkey solutions to replace and enhance equipment & systems. The flexibility & full support of these solutions based on your specific needs, secure and guarantee the performance of your cooling and heating production.



## RENTAL

- **Ready on-site temperature control or pump solution**
- **Secured production and optimal comfort**
- **Alternative to asset investments**

Whenever you need a temporary cooling or heating solution, Carrier Rental Systems organization provides tailored solutions from design through installation to decommissioning. (For seasonal capacity requirement, emergency, planned service work, facility refurbishment, event, contingency planning...)



## CONSULTANCY & REGULATION

- **HVAC expertize & recommendations**
- **Guidance for understanding & complying with energy regulations**
- **Educational sessions for your asset management**

As an expert on its equipment, Carrier offers you consultancy services on how to manage & optimize your energy consumptions and your maintenance costs. We help you to understand the fast-moving regulatory environment and to comply with it by taking into account your activity needs.



## CONTROL & MONITORING

- **Equipment, plant & system management**
- **Easy and fully secure access to your HVAC system**
- **BMS compatibility**

Our Abound HVAC Performance platform allows you to track and monitor your HVAC system and its energy consumption. Preventive and corrective actions can be taken remotely by our experts.



## ANALYSIS & OPTIMISATION

- **Actionable analysis by nearby experts**
- **Analyse plant operating data to maximize equipment lifetime**
- **Saving opportunities & optimize performance**

We innovate constantly to find the best solution for analysing and optimising your installation. Our HVAC experts provide you with diagnostics to help you save on maintenance costs and to analyze the data of your systems and their energy consumption.



## ENERGY STORAGE

- **Turnkey system solutions for all HVAC applications**
- **Shave your electrical demand**
- **Shift your electricity consumptions from peak to off peak hours**

Reducing electricity costs with continuous air conditioning throughout the year is a strong challenge for cities and customers. Installing a Thermal Energy Storage solution optimizes the design and the operation of your HVAC installation.



# EUROPEAN PARTS CENTER: BUILDING SERVICE EXCELLENCE FOR CUSTOMER



Thanks to our dedicated ERCD (EMEA Replacement Components Division) team and our factories located throughout Europe, Carrier is able to deliver 250 orders daily and ship efficiently more than 1,600 shipments per week around the world.

## A robust supply chain

### Dedicated team & expert advices

An experienced and attentive team will support you throughout the process of spare parts procurement: parts selection, management orders follow-up and logistics until delivery.

Our powerful purchasing negotiations ensures optimized pricing and lead-times. Thanks to our manufacturing expertise, we provide advice to help you find the best service solution to meet your specific needs.

- State-of-the art logistics with reliable next day delivery for Europe
- Storage permanently adjusted according to customer demand
- Accessible and reactive contacts
- Dedicated online shop to facilitate the selection of parts

## A comprehensive parts offering

### High added value parts solutions

With more than 12,000 items in stock, we propose a comprehensive parts offering including compressors, universal parts and manufactured components.

- Factory Authorized & Proprietary and universal spare parts
- Parts kits solutions
- Consultancy services
- Dedicated solutions for railways, mining & marine business

### Quality & reliability

The quality and the reliability of Carrier are integrated and guaranteed for all products & systems and extended to every spare part.

Discover our new e-commerce website dedicated to spare parts!

Visit: [www.store-eu.carrier.com](http://www.store-eu.carrier.com) to get your access!

- Order online with total autonomy
- Consult technical information & pictures of our parts
- Simplify your technical selection thanks to exploded views of end products
- Stay tuned to discover future contents!



**+90,000**  
MANAGED PART  
NUMBERS\*



[STORE-EU.CARRIER.COM](http://STORE-EU.CARRIER.COM)



**+12,000**  
ITEMS IN STOCK

\*2022 Carrier data

# CARRIER RENTAL SYSTEMS: TAILOR MADE HIRE SOLUTIONS FOR COOLING & HEATING

Specialized in temperature control, pumps and power solutions, Carrier Rental Systems operates around Europe providing comfortable, efficient, healthy, safe and secure environments for many critical and diverse applications: industry, events, data centers, hospitals, retail, offices.

## Turnkey solutions

Carrier Rental Systems provides temporary short-, medium- and long-term cooling and heating solutions for customer needs including seasonal capacity requirements, breakdown emergencies, planned service work, facility refurbishment, special events and contingency planning.

With tailored systems for commercial and industrial applications, the Carrier Rental team is committed to ensuring on-time and on-budget delivery, from system design to installation and decommissioning.

### Customized solutions

Meet changing needs throughout the year to suit fluctuations in demand or seasonal temperature changes

### Fixed monthly costs

Constant rental prices

### No extra charges

Price maintenance included with the rental fee

### Inclusive 24/7 call out

Dedicated technicians to support your daily business

### Testing before buying

Trial the equipment before buying with Carrier Rental Systems

### No need for capital expenditure

Contract based on a temporary plant basis

### New premises & short term leases

Provide the time to install a new air-conditioning system until you have expanded or refurbished your installation

### Tax relief

100% allowable against corporation tax



### Industry:

Cooling solutions for industrial petrochemical, pharmaceutical, logistics...



### Hospital:

Heating and air-conditioning rentals for hospitals and their clinic's.



### Event:

Rentals for heating and cooling units (Red bull crashed ice in Belfast).



### Hotel:

Cooling unit rentals following a system failure (Royal Garden hotel in London).



**+8,000**  
AVAILABLE MODELS



**+40**  
DEPOTS



**24/7**  
INCLUDE  
CALL OUT





# AIR-COOLED CHILLERS

## Air-cooled rotary & scroll chillers



### 30RB

- Easy and fast installation
- Compact, reliable and efficient

16 - 41 kW



## Air-cooled scroll chillers



R-32

### 30RB

- High efficiency
- Compact design
- Superior reliability
- Sustainable

40 - 160 kW



R-32

### 30RB-30RBP

- High efficiency
- Sustainable
- Easy and fast installation
- Compact, reliable and efficient

170 - 940 kW



# AIR-COOLED CHILLERS

## Air-cooled screw chillers



### 30KAV(P)

- Outstanding performance
- Intelligence and connectivity

493 - 1,079 kW



### 30KAVIZE

- Dedicated to industry
- High performance
- Low sound levels
- Environmentally responsible
- Compact dimensions
- Easy installation & maintenance

532 - 1,307 kW



### 30KAV(P)ZE

- Outstanding performance
- Intelligence and connectivity

372 - 1,344 kW



### 30XB(P)ZE

- Very economical operation
- Ease-of-use
- Exceptional reliability

210 - 1,170 kW



### 30XB(P)

- Low sound levels
- Environmentally responsible
- Exceptional reliability

277 - 1,684 kW



### 30XF

- Dedicated for data centers
- Built-in free-cooling
- Ultra fast-capacity recovery

390 - 2,100 kW





# WATER-COOLED CHILLERS

## Water-Cooled Scroll Chillers



### 30WG/30WGA

- Optimized for cooling
- Compact design
- 30WGA Condenserless version

25 - 190 kW



### 30WI

- High energy efficiency
- Compact design
- Broad field of applications

200 - 700 kW



## Water-cooled screw chillers



### 30XW-PZE

- Easy and fast installation
- Environmentally responsible

271 - 1,110 kW



### 30XW-VZE

- Low energy consumption
- High reliability
- Environmentally responsible

448 - 1,312 kW



### 30XW(P)

- High reliability
- Easy and fast installation
- Environmentally responsible

269 - 1,736 kW



### 30XW-V

- Designed to support green building design

587 - 1,741 kW





# WATER-COOLED CHILLERS

## Water-cooled centrifugal chillers



**HFO**  
R-1233zd

### 19DV

- Industry leading energy efficiency
- Advanced back-to-back two-stage compressor
- Acoustic comfort

1,200 - 3,600 kW



**R-513A**

### 19XR/XRV (1 stage)

- Single stage compressor
- Wide application
- Low sound level

1,000 - 3,000 kW



**R-513A**

### 19XR/XRV (2 stage)

- Two-stage compressor
- High lift operation
- Small footprint

2,800 - 10,500 kW





# WATER-COOLED CHILLERS

## Absorption chillers



### 16TJ (Single effect)

- Complete range 350 to 2500 kW
- Steam fired absorption chiller

352 - 2,461 kW



### 16LJ

- Complete range 83 to 4000 kW
- Hot water source from COPr up to 0.78

83 - 3,956 kW



### 16NK (Double effect)

- Steam fired absorption chiller
- High efficiency using double-effect cycle

345 - 4,652 kW



## Dry coolers



### 09PE

- Flexibility
- Energy optimization

10 - 1,100 kW



### 09VE

- Compact
- Acoustic comfort

100 - 1,870 kW



## Gasketed plate heat exchanger



### 10TE

- Economic conception
- High reliability

0 - 800 m<sup>3</sup>/h



# AIR-TO-WATER HEAT PUMPS

## Rotary and scroll air-to-water heat pumps



### 30RQ

- Easy and fast installation
- Hydraulic module available

16 - 39 kW



16 - 41 kW



## Scroll air-to-water heat pumps



### 30RQ

- Low environmental impact
- High full and part load efficiency
- Compact and simple to install
- Low refrigerant charge
- Superior reliability

40 - 160 kW



40 - 160 kW



### 61AF-030-105

- 61AF optimized for heating
- Compact design
- Plug & play approach

26 - 102 kW



### 30RQ-30RQP

- High efficiency, low operating cost
- Compact and simple to install
- Superior reliability
- Sustainable

160 - 1,000 kW



180 - 1,075 kW



## Screw air-to-water heat pumps

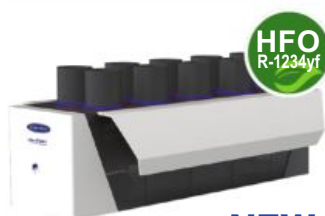

### 61CA

- Large buildings & district heating networks
- Outside air temperature from -20°C to +35°C

410 kW







# WATER-TO-WATER HEAT PUMPS

## Water-to-water scroll heat pumps



**NEW**

### 61CG

- High temperature up to 82°C
- Commercial applications
- Heat Recovery and booster solution

30 - 130 kW



### 61WG

- Optimized for high temperature heating up to 65°C
- Plug-and-play approach
- High efficiency

29 - 230 kW



### 30WG

- For low temperature heating
- Compact design

25 - 190 kW



29 - 230 kW



### 30WI

- High energy efficiency
- Compact design
- Broad field of applications

200 - 700 kW



230 - 800 kW



# WATER-TO-WATER HEAT PUMPS

## Water-to-water screw heat pumps



HFO  
R-1233zd

NEW

### 61CWD

- Ultra high temperature up to 120°C
- Ultra low GWP R1233zd refrigerant - A1 safety class for indoor installation
- Industrial process and district heating

110 - 540 kW



HFO  
R-1234ze

NEW

### 61CW-Z

- Very high temperature up to 92°C
- Industrial process heating
- District heating network

410 - 735 kW



HFO  
R-1234ze

### 61XWHZE

- Multiple applications : district heating, space heating, and process heating

300 - 1,570 kW



HFO  
R-1234ze

R-515B

### 30XWHPZE

- Low energy consumption
- High reliability
- Safe design

271 - 1,110 kW



322 - 1,297 kW



HFO  
R-1234ze

R-515B

### 30XWHVZE

- Low energy consumption
- Environmentally responsible

448 - 1,312 kW



523 - 1,555 kW



### 30XWHV

- Easy and fast installation
- Environmentally responsible

587 - 1,741 kW



648 - 1,932 kW



### 30XWH(P)

- Low operating sound system
- Environmentally responsible
- Low energy consumption

269 - 1,736 kW



317 - 2,019 kW





# FAN COIL UNITS

## ADVANCED HVAC CEILING SOLUTIONS



- High level of thermal and acoustic comfort
- High Indoor Air Quality
- Freedom of shape, lightning and sound integration, printing
- Custom made ceiling or modular panel version

## Hybrid Terminal



**NEW**

### 36XH

- Designed for hospitality
- 3 operating modes for intermittent occupancy management
- Best-in-class comfort
- High-indoor air quality

Up to 4.7 kW



Up to 8.80 kW



## Ducted terminal fan coil units



### 42EP

- Optimised energy consumption level
- Extra slim only 150 mm height

0.4 - 4.2 kW



0.5 - 5 kW



### 42NH

- Modular horizontal ducted unit
- Low energy consumption

0.6 - 12 kW



0.8 - 17 kW



## Concealed terminal fan coil units



### 42ND

- Energy efficiency and ecodesign compliant
- Versatile and polyvalent horizontal and vertical installation

0.7 - 8.7 kW



1.0 - 9.15 kW



### 42NL

- Extremely quiet operation
- Flexibility for simplified installation

0.6 - 12 kW



0.8 - 17 kW





# FAN COIL UNITS

## Console and cassette fan coil units



### 42SI

- Extra slim
- 4 models available

0.55 - 2.9 kW



0.57 - 2.5 kW



### 42NC

- Energy efficiency and ecodesign compliant
- Versatile and polyvalent horizontal and vertical installation

0.7 - 8.7 kW



1.0 - 9.15 kW



### 42KY

- Coanda effect for optimised diffusion
- Acoustic comfort
- Modern design for high aesthetical level
- 180° diffusion panel

1 - 6 kW



2 - 10 kW



### 42GW

- Versatility and easy installation
- Optimized 4-way diffusion

1.5 - 9.5 kW



1.3 - 11.3 kW



## High-wall



### 42WM

- Versatile and compact
- Energy efficiency
- Thermal and acoustic comfort

1.2 - 3.8 kW



1.3 - 4.3 kW



## Air heater



### 42AM

- Ensures ultra-fast thermal comfort
- Available with low consumption EC motor

1,400 - 11,000 m<sup>3</sup>/h





# AIR TREATMENT SYSTEMS

## Air handling units



**NEW**

### 39CS

- AHU for ventilation with heat recovery
- Plug&play unit

550 - 3,200 m<sup>3</sup>/h



### 39CQ

- Modular Ultra-Slim AHU
- Ideal for a compact installation

1,000 - 6,000 m<sup>3</sup>/h



### 39HX

- Plug & play unit
- High-efficiency heat recovery unit
- High performance plug fan

300 - 18,000 m<sup>3</sup>/h



### 39CP

- AHU for all application
- Designed to conform to standards

1,000 - 30,000 m<sup>3</sup>/h



### 39CZ

- The effective solution for service sector, industry and healthcare applications

25,000- 60,000 m<sup>3</sup>/h



### 39HQ

- Extremely quiet operation
- Flexibility for simplified installation

5,000 - 130,000 m<sup>3</sup>/h



# AIR TREATMENT SYSTEMS

## Close control units



### 50CJ

- Compact footprint
- Dual-wall construction
- PLC control

5 - 47 kW



4 - 41 kW



1,300 - 12,000 m<sup>3</sup>/h



### 50CO

- Optimised Coanda effect diffusion
- Air quality

40 - 100 kW



18 - 73 kW



10,000 - 27,000 m<sup>3</sup>/h



## Rooftops



R-454B

**NEW**  
50FF VERSION

### 50FF/FC 020-093

*Version with R-410A is also available*

- Low environmental impact
- High seasonal efficiency SEER/SCOP
- Energy savings
- Air quality
- Extensive scope

22 - 90 kW



22 - 90 kW



R-454B

### 50FF/FC 100-280

*Version with R-410A is also available*

- Low environmental impact
- High seasonal efficiency SEER/SCOP
- Energy savings
- Air quality
- Extensive scope

97 - 273 kW



97 - 299 kW



10,800-54,000 m<sup>3</sup>/h



## Vertical packaged



**NEW**

### 50NC

- Vertical air-to-air units
- Package and split versions
- High adaptability
- Air quality
- Extensive scope
- Optimize dimensions

22 -120 kW



21 - 121 kW



4,000-22,200 m<sup>3</sup>/h







# DISCOVER ALSO XCT7, OUR VRF SYSTEM RANGE

[Click here](#)



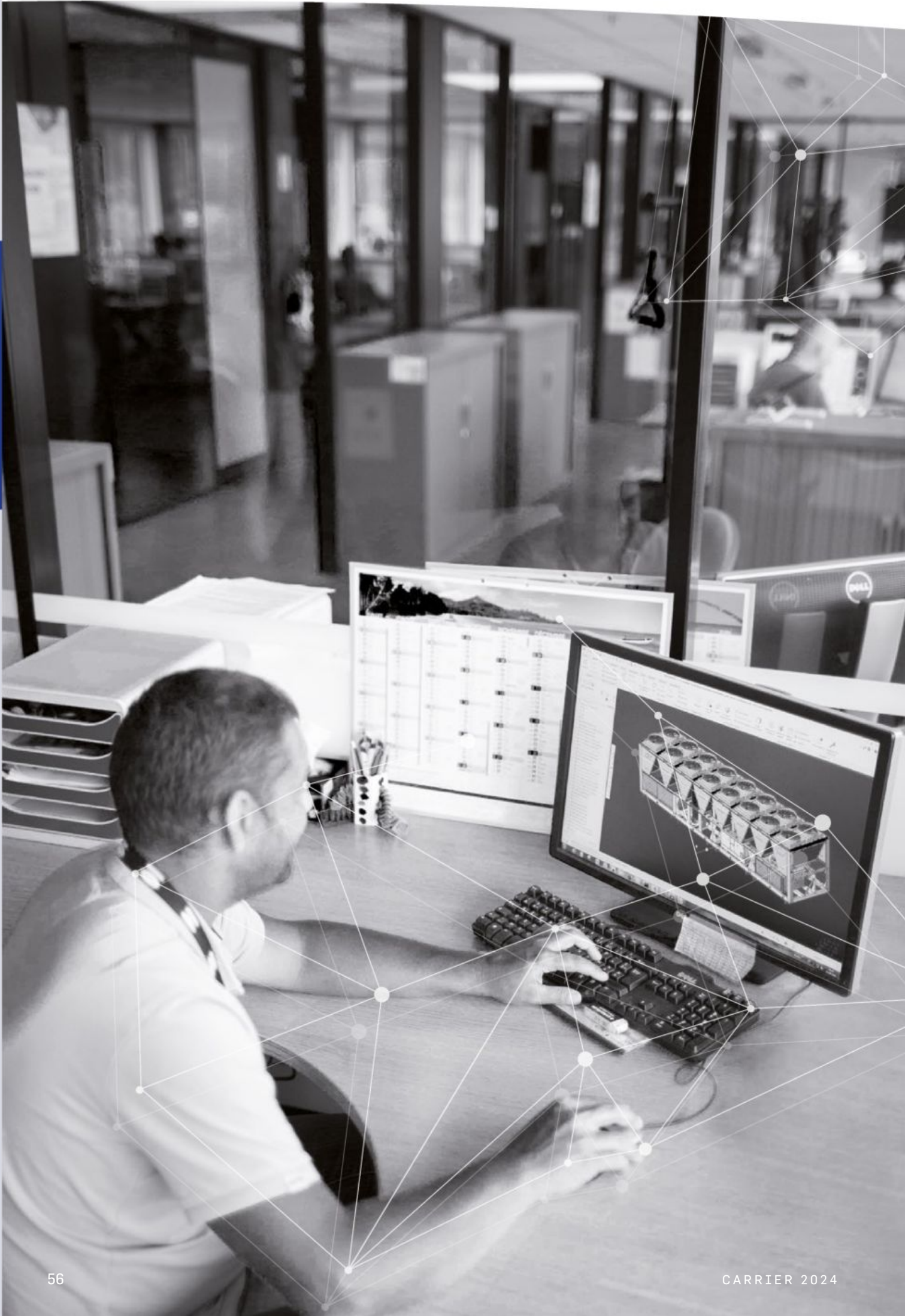



# Cooling

Type	Range	Refrigerant	Cooling capacity, kW	Page
<b>Air-cooled units</b>				
With rotary compressors	30RB 017-021	R-410A	16-21	59
	30RB 026-040	R-410A	27-41	69
With scroll compressors	30RB 040R-160R	R-32	40-160	77
	30RB/30RBP 170R-950R	R-32	170-940	101
With screw compressors	30KAV(P)	R-134a	493-1079	151
	30KAV(P)ZE/ 30KAVIZE	R-1234ze	372-1344	185
	30XB(P)ZE	R-1234ze	210-1170	231
	30XB(P)	R-134a	277-1684	259
	NEW 30XF	R-1234ze	390-2100	291
<b>Water-cooled units</b>				
With scroll compressors	30WG/30WGA	R-410A	25-190	305
	30WI	R-410A	200-700	339
With screw compressors	30XW-PZE	R-1234ze	271-1110	349
	30XW-VZE	R-1234ze	448-1312	363
	30XW(P)	R-134a	269 - 1736	375
	30XW-V	R-134a	587-1741	403
With centrifugal compressors	19DV	R-1233zd	1200-3600	415
	19XR/XRV single stage	R-134a	1000-3000	421
	19XR/XRV double stage	R-134a	2800-10500	425
<b>Absorption chillers</b>				
<b>Single-effect</b>				
Steam-fired absorption chillers	16TJ	-	352-2461	429
Hot water-fired absorption chillers	16LJ-F	-	83-3956	439
<b>Double-effect</b>				
Steam-fire absorption chillers	16NK	-	345-4652	475
<b>Air-cooled dry coolers</b>				
With axial fan	09PE	-	10-1100	479
	09VE	-	180-1870	485
<b>Gasketed plate heat exchangers</b>	10TE	-		489



## AIR-COOLED LIQUID CHILLERS



Easy and fast installation  
Hydraulic module available  
Economical operation  
Superior reliability

## 30RB 017-021 A



Nominal cooling capacity 30RB: 16-21 kW

The Aquasnap liquid chiller/heat pump range was designed for commercial applications such as the air conditioning of offices and hotels etc.

The new Aquasnap units integrate the latest technological innovations:

- Ozone-friendly refrigerant R410A
- Scroll compressors
- Low-noise fans
- Auto-adaptive microprocessor control

The Aquasnap units are equipped with a hydraulic module integrated into the unit chassis, limiting the installation to straightforward operations like connection of the power supply and the water supply and return piping.



## FEATURES

### Quiet operation

- Compressors
  - Low-noise scroll compressors with low vibration levels
  - The compressor assembly is supported by anti-vibration mountings
- Air heat exchanger section
  - Vertical air heat exchanger coils
  - The latest-generation low-noise fans are now even quieter and do not generate intrusive low-frequency noise
  - Rigid fan installation for reduced start-up noise.

### Access panels, 30RB 017-021



### Easy and fast installation

- Integrated hydraulic module
  - Fixed speed circulator
  - Water filter protecting the water pump against circulating debris
  - High-capacity membrane expansion tank ensures pressurisation of the water circuit
  - Overpressure valve, set to 4 bar
  - Automatic purge valve positioned at the highest point of the hydraulic module to remove air from the system.
  - Thermal insulation and frost protection down to -10°C, using an electric resistance heater and pump cycling.
  - Integrated water fill system to ensure correct water pressure (option)
- Physical features
  - With its small footprint the unit blends in with any architectural styles.
  - The unit is enclosed by easily removable panels, covering all components (except air heat exchanger and fans).
- Simplified electrical connections
  - A single power supply point (power supply without neutral available as an option)
  - Main disconnect switch with high trip capacity
  - Transformer for safe 24 V control circuit supply included
- Fast commissioning
  - Systematic factory operation test before shipment
  - Quick-test function for step-by-step verification of the instruments, electrical components and motors.

## FEATURES

### Economical operation

- Increased energy efficiency at part load
  - In accordance with standard EN 14825/2022 in average climate, the Seasonal Coefficient of performance (SCOP) reaches 3.01 for an energy label of A.
  - Specific Free Defrost algorithm is present to optimise performance and comfort even during defrost period.
- Reduced maintenance costs
  - Maintenance-free scroll compressors
  - Fast diagnosis of possible incidents and their history via the Pro-Dialog+ control
  - R410A refrigerant is easier to use than other refrigerant blends

### Environmental care

- Ozone-friendly R410A refrigerant
  - Chlorine-free refrigerant of the HFC group with zero ozone depletion potential
  - Very efficient - gives an increased energy efficiency ratio (EER)
- Leak-tight refrigerant circuit
  - Brazed refrigerant connections for increased leak-tightness
  - Verification of pressure transducers and temperature sensors without transferring refrigerant charge

### Superior reliability

- State-of-the-art concept
  - Cooperation with specialist laboratories and use of limit simulation tools (finite element calculations) for the design of the critical components, e.g. motor supports, suction/discharge piping etc.
- Auto-adaptive control
  - Control algorithm prevents excessive compressor cycling and permits reduction of the water quantity in the hydraulic circuit (Carrier patent)
- Exceptional endurance tests
  - Corrosion resistance tests in salt mist in the laboratory
  - Accelerated ageing test on components that are submitted to continuous operation: compressor piping, fan supports
  - Transport simulation test in the laboratory on a vibrating table.

### Pro-Dialog+ control

Pro-Dialog+ combines intelligence with operating simplicity. The control constantly monitors all machine parameters and precisely manages the operation of compressors, expansion devices, fans and of the water heat exchanger water pump for optimum energy efficiency.

#### Pro-Dialog+ interface

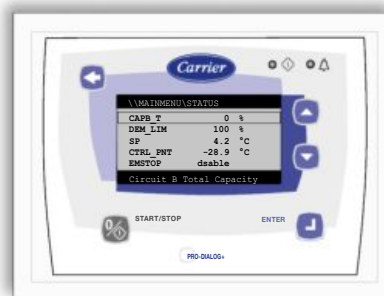

- Energy management
  - Seven-day internal time schedule clock: Permits unit on/off control and operation at a second set point
  - Set point reset based on the outside air temperature or the return water temperature or on the water heat exchanger delta T
  - Master/slave control of two units operating in parallel with operating time equalisation and automatic change-over in case of a unit fault.
  - Change-over based on the outside air temperature
- Integrated features
  - Night mode: Capacity and fan speed limitation for reduced noise level
- Ease-of-use
  - The new backlit LCD interface includes a manual control potentiometer to ensure legibility under any lighting conditions.
  - The information is displayed clearly in English, French, German, Italian and Spanish (for other languages please consult Carrier)
  - The Pro-Dialog+ navigation uses intuitive tree-structure menus, similar to the Internet navigators. They are user-friendly and permit quick access to the principal operating parameters: number of compressors operating, suction/discharge pressure, compressor operating hours, set point, air temperature, entering/leaving water temperature.



## FEATURES

### Remote operating mode with volt-free contacts (standard)

A simple two-wire communication bus between the RS485 port of the Aquasnap and the Carrier Comfort Network offers multiple remote control, monitoring and diagnostic possibilities. Carrier offers a vast choice of control products, specially designed to control, manage and supervise the operation of an air conditioning system. Please consult your Carrier representative for more information on these products.

- Start/stop: Opening of this contact will shut down the unit
- Dual set point: Closing of this contact activates a second set point (example: Unoccupied mode)
- Alert indication: This volt-free contact indicates the presence of a minor fault
- Alarm indication: This volt-free contact indicates the presence of a major fault that has led to the shut-down of the unit
- User safety: This contact can be used for any customer safety loop, closing of the contact generates a specific alarm
- Out of service: This signal indicates that the unit is completely out of service
- Unit capacity: This analogue output (0-10 V) gives an immediate indication of the unit capacity
- Compressor operation: This contact signals that the compressor is in operation

### Remote interface (option)

This interface allows access to the same menus as the unit interface and can be installed up to 300 m away. It includes a box that can be mounted inside the building. The power supply is provided via a 220 V/24V transformer supplied.

## TYPE KEY

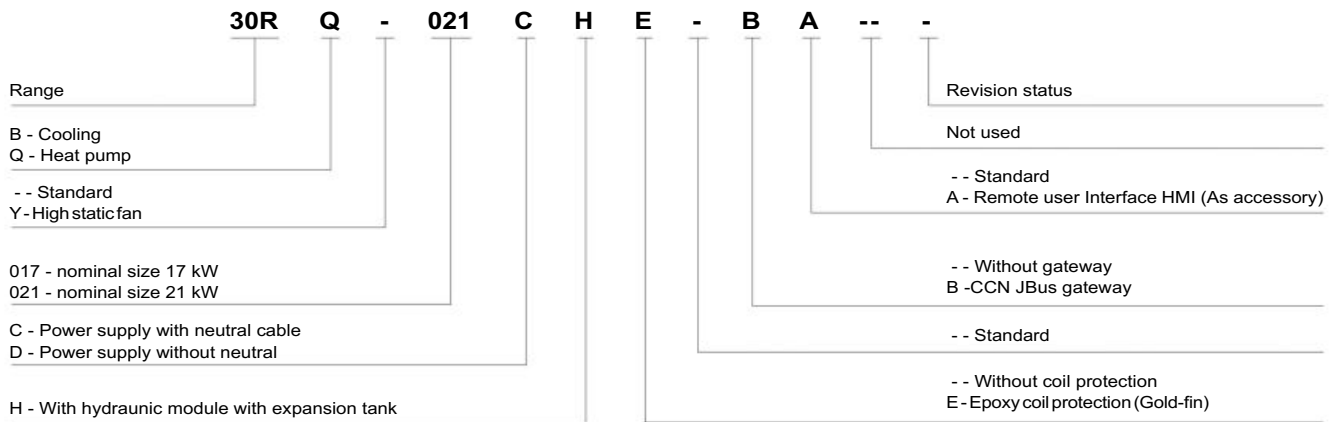

## PHYSICAL DATA, 30RB UNITS

30RB Cooling Only			017	021	
<b>Cooling</b>					
<b>Full Load</b>	CA1	Nominal capacity	kW	16,5	21,5
		EER	kW/kW	3,08	3,16
	CA2	Nominal capacity	kW	22,8	29,8
		EER	kW/kW	3,88	3,92
<b>Seasonal Efficiencies</b>	<b>SEPR<sub>-2/-8°C</sub> Process medium temp.*** kWh/kWh</b>			<b>2,99</b>	<b>3,03</b>
	SEPR <sub>12/7°C</sub> Process high temp.		kWh/kWh	5,46	5,42
	SEER <sub>12/7°C</sub> Comfort low temp.		kWh/kWh	3,53	3,53
	SEER <sub>23/18°C</sub> Comfort medium temp.		kWh/kWh	4,22	4,08
<b>Operating weight<sup>(1)</sup></b>					
Standard unit, with hydraulic module		kg	189	208	
Standard unit, without hydraulic module		kg	173	93	
<b>Sound power level<sup>(2)</sup></b>		dB(A)	72	74	
Sound pressure level at 10 m <sup>(3)</sup>		dB(A)	40	42	
<b>Dimensions</b>					
Length		mm	1136		
Depth		mm	584		
Height		mm	1579		
<b>Compressor</b>		One hermetic scroll compressor			
<b>Refrigerant charge R-410A</b>		kg	5,5	6,4	
		teqCO <sub>2</sub>	11,5	13,4	
<b>Control</b>		Pro-Dialog+			
<b>Fans</b>		Two twin-speed axial fans, 3 blades			
Diameter		mm	495	495	
Air flow		l/s	2212	2212	
Speed		r/s	14,5	14,5	
<b>Water heat exchanger</b>		Plate heat exchanger, maximum operating pressure 1000 kPa			
Water volume		l	1,52	1,9	

- \* In accordance with standard EN14511-3:2022  
 \*\* In accordance with standard EN14825:2022, average climate  
 \*\*\* With EG 30%
- CA1 Cooling mode conditions: Evaporator water entering/leaving temperature 12°C/7°C, outside air temperature 35°C, evaporator fouling factor 0 m<sup>2</sup>.K/W
- CA2 Cooling mode conditions: Evaporator water entering/leaving temperature 23°C/18°C, outside air temperature 35°C, evaporator fouling factor 0 m<sup>2</sup>.K/W
- SEPR<sub>-2/-8°C</sub>**  
**SEER<sub>12/7°C</sub> & SEPR<sub>12/7°C</sub>**  
**SEER<sub>23/18°C</sub>**  
**IPLV.SI**
- Bold values compliant to Ecodesign regulation: (EU) No 2015/1095 for Process application**  
 Values calculated in accordance with EN14825:2022  
 Values calculated in accordance with EN14825:2022
- Calculations according to standard performances AHRI 551-591 (SI)  
 Weight shown is a guideline only. Please refer to the unit nameplate
- (1) In dB ref=10<sup>-12</sup> W, (A) weighting. Declared dualnumber noise emission values in accordance with ISO 4871 (with an associated uncertainty of +/-3dB(A)). Measured in accordance with ISO 9614-1 and certified by Eurovent.
- (2) In dB ref 20μPa, (A) weighting. Declared dualnumber noise emission values in accordance with ISO 4871 (with an associated uncertainty of +/-3dB(A)). For information, calculated from the sound power level Lw(A).
- (3) In dB ref 20μPa, (A) weighting. Declared dualnumber noise emission values in accordance with ISO 4871 (with an associated uncertainty of +/-3dB(A)). For information, calculated from the sound power level Lw(A).





## PHYSICAL DATA, 30RB UNITS

30RB Cooling Only		017	021
<b>Air heat exchanger</b>		Copper tubes and aluminum fins	
Pipe diameter	in	3/8	3/8
Number of rows		2	2
Number of pipes per row		60	60
Fin spacing	mm	1,69	1,69
<b>Standard unit</b>			
Water connections (MPT gas)	in	1	1
<b>Unit with hydraulic module</b>		Pump, screen filter, expansion tank, flow switch, pressure gauge, automatic air purge valve, relief valve	
Pump		One single-speed pump, maximum water-side operating pressure 400 kPa	
Expansion tank capacity	l	5	5
Entering water connection	in	1-1/4	1-1/4
Leaving water connection	in	1	1
Nominal operating current	A	1,3	1,4
<b>Chassis paint colour</b>		Beige	

## PHYSICAL DATA, 30RQ UNITS

30RQ 017-040 Reversible			017	021	
<b>Heating</b>					
<b>Full Load</b>	HA1	Nominal capacity	kW	17,5	21,7
		COP	kW/kW	4,06	4,00
	HA2	Nominal capacity	kW	16,9	21,3
		COP	kW/kW	3,23	3,30
	HA3	Nominal capacity	kW	16,3	20,6
		COP	kW/kW	2,59	2,62
<b>Seasonal Efficiencies</b>	HA1	<b>SCOP</b> <sub>30/35°C</sub>	<b>kWh/kWh</b>	<b>3,33</b>	<b>3,32</b>
		<b>η<sub>s</sub> heat</b>	<b>%</b>	<b>130</b>	<b>130</b>
		P <sub>rated</sub>	kW	13	13
		Energy labelling		A++	A++
<b>Cooling</b>					
<b>Full Load</b>	CA1	Nominal capacity	kW	15,9	20,0
		EER	kW/kW	3,14	3,08
	CA2	Nominal capacity	kW	22,0	27,1
		EER	kW/kW	4,01	3,75
<b>Seasonal Efficiencies</b>		SEPR <sub>12/7°C</sub> Process high temp.	kWh/kWh	5,58	5,34
		SEER <sub>12/7°C</sub> Comfort low temp.	kWh/kWh	3,59	3,44
		SEER <sub>23/18°C</sub> Comfort medium temp.	kWh/kWh	4,33	3,96
<b>Operating weight<sup>(1)</sup></b>					
		Standard unit, with hydraulic module	kg	206	223
		Standard unit, without hydraulic module	kg	191	208
<b>Sound power level<sup>(2)</sup></b>					
		Sound power level at 10 m <sup>(3)</sup>	dB(A)	72	74
			dB(A)	40	42
<b>Dimensions</b>					
		Length	mm	1136	
		Depth	mm	584	
		Height	mm	1579	
<b>Compressor</b>					
				One hermetic scroll compressor	
<b>Refrigerant charge R-410A</b>					
			kg	6,4	7,7
			teqCO <sub>2</sub>	13,4	16,1
<b>Control</b>					
				Pro-Dialog+	

- \* In accordance with standard EN14511-3:2022
- \*\* In accordance with standard EN14825:2022, average climate
- HA1 Heating mode conditions: Water heat exchanger water entering/leaving temperature 30°C/35°C, outside air temperature tdb/twb = 7°C db/6°C wb, evaporator fooling factor 0 m<sup>2</sup>.K/W
- HA2 Heating mode conditions: Water heat exchanger water entering/leaving temperature 40°C/45°C, outside air temperature tdb/twb= 7°C db/6°C wb, evaporator fooling factor 0 m<sup>2</sup>.K/W
- CA1 Cooling mode conditions: evaporator water entering/leaving temperature 12°C/7°C, outside air temperature 35°C, evaporator fooling factor 0 m<sup>2</sup>.K/W
- CA2 Cooling mode conditions: evaporator water entering/leaving temperature 23°C/18°C, outside air temperature 35°C, evaporator fooling factor 0 m<sup>2</sup>.K/W
- η<sub>s</sub> heat<sub>30/35°C</sub> & SCOP<sub>30/35°C</sub>** **Bold values compliant to Ecodesign regulation: (EU) No 813/2013 for Heat Pump application**
- SEER<sub>12/7°C</sub> & SEPR<sub>12/7°C</sub> Values calculated in accordance with EN14825:2022
- SEER<sub>23/18°C</sub> Values calculated in accordance with EN14825:2022
- IPLV.SI Calculations according to standard performances AHRI 551-591 (SI)
- (1) Weight shown is a guideline only. Please refer to the unit nameplate
- (2) In dB ref=10<sup>-12</sup> W, (A) weighting. Declared dualnumber noise emission values in accordance with ISO 4871 (with an associated uncertainty of +/-3dB(A)). Measured in accordance with ISO 9614-1 and certified by Eurovent.
- (3) In dB ref 20μPa, (A) weighting. Declared dualnumber noise emission values in accordance with ISO 4871 (with an associated uncertainty of +/-3dB(A)). For information, calculated from the sound power level Lw(A).



## PHYSICAL DATA, 30RQ UNITS

30RQ 017-040 Reversible		017	021
<b>Fans</b>		Two twin-speed axial fans, 3 blades	
Diameter	mm	495	495
Air flow	l/s	2217	1978
Speed	r/s	14,5	14,5
<b>Water heat exchanger</b>		Plate heat exchanger, maximum operating pressure 1000 kPa	
<b>Water volume</b>	l	1,52	1,9
<b>Air heat exchanger</b>		Copper tubes and aluminum fins	
Pipe diameter	in	3/8	3/8
Number of rows		2,5	3
Number of pipes per row		60	60
Fin spacing	mm	1,69	1,69
<b>Standard unit</b>			
Water connections (MPT gas)	in	1	1
<b>Unit with hydraulic module</b>		Pump, screen filter, expansion tank, flow switch, pressure gauge, automatic air purge valve, relief valve	
Pump		One single-speed pump, maximum water-side operating pressure 400 kPa	
Expansion tank capacity	l	5	5
Entering water connection	in	1-1/4	1-1/4
Leaving water connection	in	1	1
Nominal operating current	A	1,3	1,4
<b>Chassis paint colour</b>		Beige	

## ELECTRICAL DATA, 30RB/RQ UNITS

30RB/RQ		017	021
<b>Power circuit</b>			
Nominal power supply	V-ph-Hz	400-3+N-50 (power supply option C) or 400-3-50 (power supply option D)	
Voltage range	V	340-460	
<b>Control circuit supply</b>			
24 V via internal transformer			
<b>Maximum start-up current (Un)<sup>(1)</sup></b>	A	75	95
<b>Unit power factor at nominal capacity<sup>(2)</sup></b>		0,84	0,79
<b>Maximum operating power input<sup>(2)</sup></b>	kW	7,8	9,1
<b>Nominal current drawn<sup>(3)</sup></b>	A	8	12
<b>Maximum operating current draw (Un)<sup>(4)</sup></b>	A	13	16
<b>Maximum operating current draw (Un-15%)<sup>(5)</sup></b>	A	15	18

(1) Maximum instantaneous start-up current (locked rotor current of the compressor).

(2) Power input, compressors and fans, at the unit operating limits (saturated suction temperature 10°C, saturated condensing temperature 65°C) and nominal voltage of 400 V (data given on the unit nameplate).

(3) Standardised Eurovent conditions: Water heat exchanger entering/leaving water temperature 12°C/7°C, outside air temperature 35°C.

(4) Maximum unit operating current at maximum unit power input and 400 V (values given on the unit nameplate).

(5) Maximum unit operating current at maximum unit power input and 340-460V.



**DIMENSIONS/CLEARANCES**

**30RB/RQ 017-021**

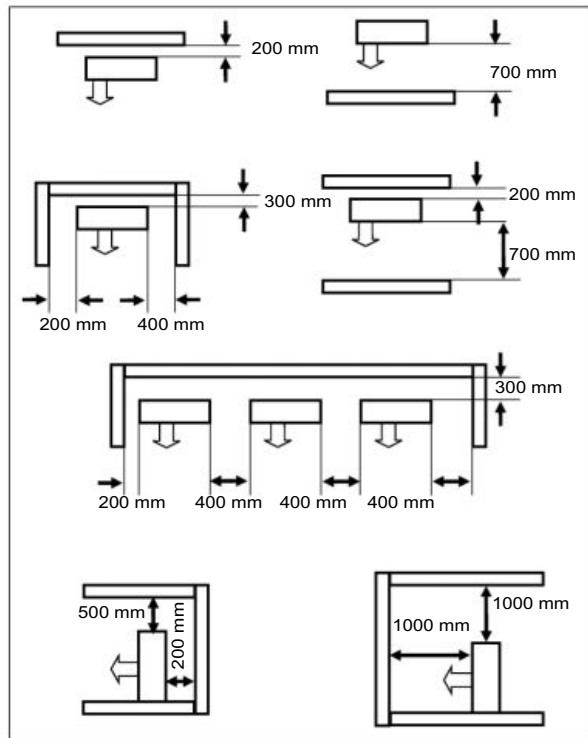
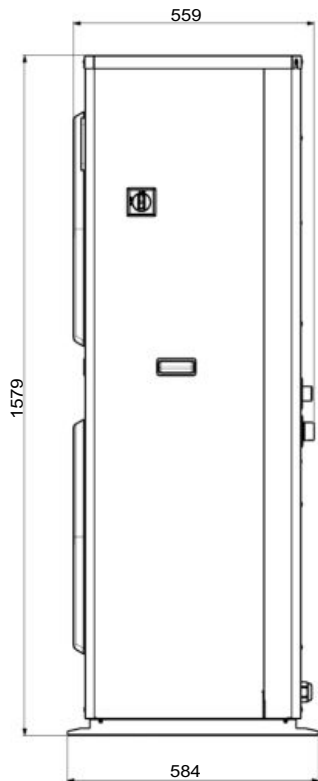
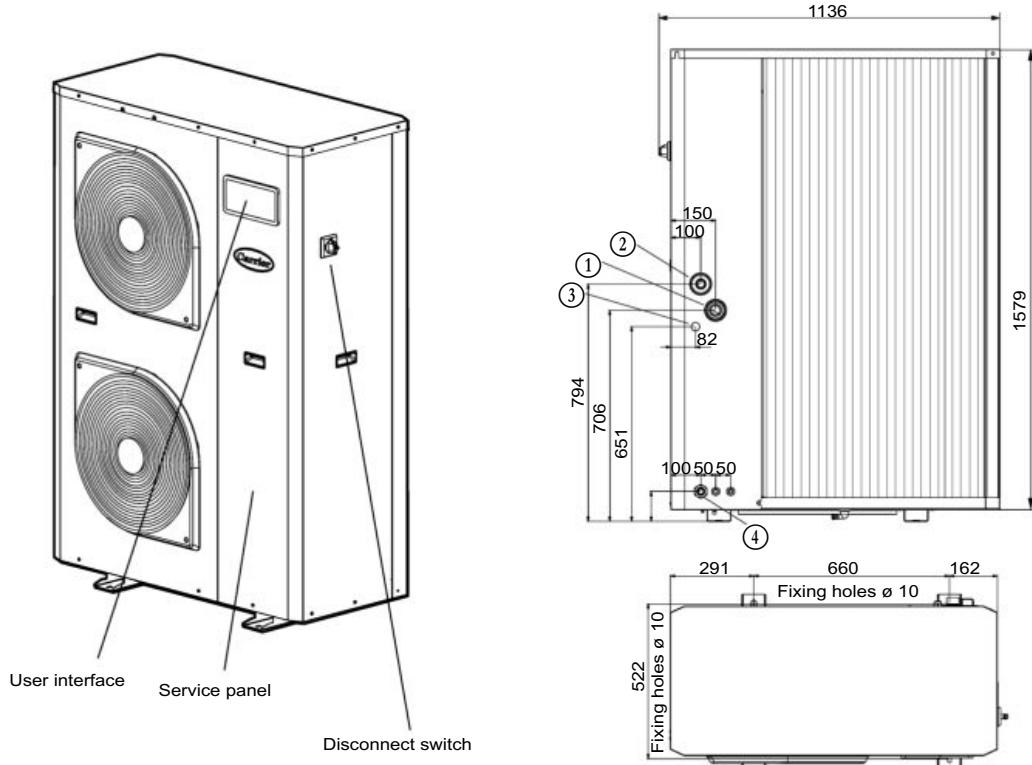

**Legend**

All dimensions are in mm

- ① Water inlet
- ② Water outlet
- ③ Water fill kit connection (option)
- ④ Power connections

## AIR-COOLED LIQUID CHILLERS



- Easy and fast installation
- Hydraulic module available
- Economical operation
- Superior reliability

# 30RB 026-040 A

## AQUASNAP.

Nominal cooling capacity 30RB: 27 - 41 kW

The Aquasnap liquid chiller/heat pump range was designed for commercial applications such as the air conditioning of offices and hotels etc.

The new Aquasnap units integrate the latest technological innovations:

- Non-ozone depleting refrigerant R-410A
- Scroll compressors
- Low-noise fans
- Auto-adaptive microprocessor control

The Aquasnap units are equipped with a hydraulic module integrated into the unit chassis, limiting the installation to straightforward operations like connection of the power supply and the water supply and return piping.



CARRIER participates in the ECP programme for LCP-HP  
Check ongoing validity of certificate:  
[www.eurovent-certification.com](http://www.eurovent-certification.com)

## FEATURES

### Quiet operation

- Compressors
  - Low-noise scroll compressors with low vibration levels
  - The compressor assembly is supported by anti-vibration mountings
- Air heat exchanger section
  - Vertical air heat exchanger coils
  - The latest-generation low-noise fans are now even quieter and do not generate intrusive low-frequency noise
  - Rigid fan installation for reduced start-up noise.

### Easy and fast installation

- Integrated hydraulic module
  - Fixed speed circulator
  - Water filter protecting the water pump against circulating debris
  - High-capacity membrane expansion tank ensures pressurisation of the water circuit
  - Overpressure valve, set to 4 bar
  - Automatic purge valve positioned at the highest point of the hydraulic module to remove air from the system.
  - Thermal insulation and frost protection down to -10°C, using an electric resistance heater and pump cycling.
  - Integrated water fill system to ensure correct water pressure (option)
- Physical features
  - With its small footprint the unit blends in with any architectural styles.
  - The unit is enclosed by easily removable panels, covering all components (except air heat exchanger and fans).
- Simplified electrical connections
  - A single power supply point (power supply without neutral available as an option and in standard for units size 40kW)
  - Main disconnect switch with high trip capacity
  - Transformer for safe 24 V control circuit supply included
- Fast commissioning
  - Systematic factory operation test before shipment
  - Quick-test function for step-by-step verification of the instruments, electrical components and motors.

### Economical operation

- Increased energy efficiency at part load
  - In accordance with standard EN 14825/2022 in average climate, the Seasonal Coefficient of performance (SCOP) reaches 3,27 for an energy label of A.
  - Specific Free Defrost algorithm is present to optimise performance and comfort even during defrost period.
- Reduced maintenance costs
  - Maintenance-free scroll compressors
  - Fast diagnosis of possible incidents and their history via the Pro-Dialog+ control
  - R-410A refrigerant is easier to use than other refrigerant blends

### Environmental care

- Ozone-friendly R-410A refrigerant
  - Chlorine-free refrigerant of the HFC group with zero ozone depletion potential
  - Very efficient - gives an increased energy efficiency ratio (EER/SEER/COP/SCOP)
- Leak-tight refrigerant circuit
  - Brazed refrigerant connections for increased leak-tightness
  - Verification of pressure transducers and temperature sensors without transferring refrigerant charge

#### Hydraulic module



### Superior reliability

- State-of-the-art concept
  - Cooperation with specialist laboratories and use of limit simulation tools (finite element calculations) for the design of the critical components, e.g. motor supports, suction/discharge piping etc.
- Auto-adaptive control
  - Control algorithm prevents excessive compressor cycling and permits reduction of the water quantity in the hydraulic circuit (Carrier patent).
- Exceptional endurance tests
  - Corrosion resistance tests in salt mist in the laboratory
  - Accelerated ageing test on components that are submitted to continuous operation: compressor piping, fan supports
  - Transport simulation test in the laboratory on a vibrating table.

## FEATURES

### Pro-Dialog+ control

Pro-Dialog+ combines intelligence with operating simplicity. The control constantly monitors all machine parameters and precisely manages the operation of compressors, expansion devices, fans and of the water heat exchanger water pump for optimum energy efficiency.

#### Pro-Dialog+ interface

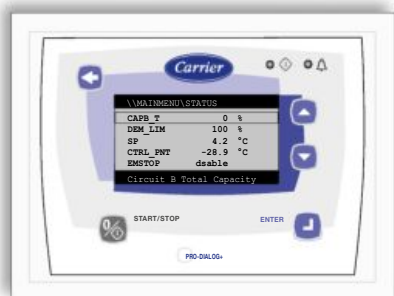

- Energy management
  - Seven-day internal time schedule clock: Permits unit on/off control and operation at a second set point
  - Set point reset based on the outside air temperature or the return water temperature or on the water heat exchanger delta T
  - Master/slave control of two units operating in parallel with operating time equalisation and automatic change-over in case of a unit fault.
  - Change-over based on the outside air temperature
- Integrated features
  - Night mode: Capacity and fan speed limitation for reduced noise level
- Ease-of-use
  - The new backlit LCD interface includes a manual control potentiometer to ensure legibility under any lighting conditions.
  - The information is displayed clearly in English, French, German, Italian and Spanish (for other languages please consult Carrier)
  - The Pro-Dialog+ navigation uses intuitive tree-structure menus, similar to the Internet navigators. They are user-friendly and permit quick access to the principal operating parameters: number of compressors operating, suction/discharge pressure, compressor operating hours, set point, air temperature, entering/leaving water temperature.

### Remote operating mode with volt-free contacts (standard)

A simple two-wire communication bus between the RS485 port of the Aquasnap and the Carrier Comfort Network offers multiple remote control, monitoring and diagnostic possibilities. Carrier offers a vast choice of control products, specially designed to control, manage and supervise the operation of an air conditioning system. Please consult your Carrier representative for more information on these products.

- Start/stop: Opening of this contact will shut down the unit
- Dual set point: Closing of this contact activates a second set point (example: Unoccupied mode)
- Alert indication: This volt-free contact indicates the presence of a minor fault
- Alarm indication: This volt-free contact indicates the presence of a major fault that has led to the shut-down of the unit
- User safety: This contact can be used for any customer safety loop, closing of the contact generates a specific alarm
- Out of service: This signal indicates that the unit is completely out of service
- Unit capacity: This analogue output (0-10 V) gives an immediate indication of the unit capacity
- Compressor operation: This contact signals that the compressor is in operation

### Remote interface (option)

This interface allows access to the same menus as the unit interface and can be installed up to 300 m away. It includes a box that can be mounted inside the building. The power supply is provided via a 220 V/24V transformer supplied.

#### Interface access





PERFORMANCES DATA, 30RB / 30RQ UNITS

			30RB 26	30RB 33	30RB 40	30RQ 26	30RQ 33	30RQ 40	
<b>Heating</b>									
<b>Standard unit</b> Full load performances*	HA1	Nominal capacity	kW	-	-	-	30,4	34,0	38,4
		COP	kW/kW	-	-	-	3,99	3,99	3,53
	HA2	Nominal capacity	kW	-	-	-	29,4	32,8	40,6
		COP	kW/kW	-	-	-	3,22	3,20	3,17
<b>Standard unit</b> Seasonal energy efficiency**	HA1	<b>SCOP<sub>30/35°C</sub></b>	<b>kW/kW</b>	-	-	-	<b>3,34</b>	<b>3,34</b>	<b>3,30</b>
		<b>η<sub>s heat</sub><sub>30/35°C</sub></b>	<b>%</b>	-	-	-	<b>131</b>	<b>131</b>	<b>129</b>
		<b>P<sub>rated</sub></b>	<b>kW</b>	-	-	-	20	23	31
		Energy labelling		-	-	-	A++	A++	A++
<b>Cooling</b>									
<b>Standard unit</b> Full load performances*	CA1	Nominal capacity	kW	27,5	33,5	41,5	26,4	32,5	39,4
		EER	kW/kW	3,12	3,32	2,99	2,98	3,19	2,88
	CA2	Nominal capacity	kW	38,9	46,2	57,1	34,2	43,2	54,4
		EER	kW/kW	4,03	4,15	3,55	3,61	3,92	3,46
<b>Standard unit</b> Seasonal energy efficiency**		<b>SEPR<sub>-2/-8°C</sub> Process medium temp.***</b>	<b>kWh/kWh</b>	<b>3,17</b>	<b>3,02</b>	<b>3,07</b>	-	-	-
		SEPR <sub>12/7°C</sub> Process high temp.	kWh/kWh	5,25	5,28	5,18	5,06	5,20	3,98
		SEER <sub>12/7°C</sub> Comfort low temp.	kWh/kWh	3,44	3,63	3,53	3,39	3,57	3,41
		SEER <sub>23/18°C</sub> Comfort medium temp.	kWh/kWh	3,96	4,08	4,04	3,87	4,02	3,96
Integrated Part Load Value	IPLV.SI	kW/kW	4,340	4,540	4,030	4,068	4,352	3,846	
<b>Operating weight<sup>(1)</sup></b>									
Standard unit, with hydraulic module			kg	255	280	291	280	295	305
Standard unit, without hydraulic module			kg	237	262	273	262	277	287
<b>Sound power level<sup>(2)</sup></b>			dB(A)	78	78	80	78	78	80
Sound pressure level at 10 m <sup>(3)</sup>			dB(A)	46	46	48	46	46	48

\* In accordance with standard EN14511-3:2022  
 \*\* In accordance with standard EN14825:2022, average climate  
 HA1 Heating mode conditions: Water heat exchanger water entering/leaving temperature 30°C/35°C, outside air temperature tdb/twb = 7°C db/6°C wb, evaporator frosting factor 0 m<sup>2</sup>.K/W  
 HA2 Heating mode conditions: Water heat exchanger water entering/leaving temperature 40°C/45°C, outside air temperature tdb/twb = 7°C db/6°C wb, evaporator frosting factor 0 m<sup>2</sup>.K/W  
 CA1 Cooling mode conditions: evaporator water entering/leaving temperature 12°C/7°C, outside air temperature 35°C, evaporator frosting factor 0 m<sup>2</sup>.K/W  
 CA2 Cooling mode conditions: evaporator water entering/leaving temperature 23°C/18°C, outside air temperature 35°C, evaporator frosting factor 0 m<sup>2</sup>.K/W  
**η<sub>s heat</sub><sub>30/35°C</sub> & SCOP<sub>30/35°C</sub>** **Bold values compliant to Ecodesign regulation: (EU) No 813/2013 for Heat Pump application**  
**SEPR<sub>-2/-8°C</sub>** **Bold values compliant to Ecodesign regulation: (EU) No 2015/1095 for Process application**  
**SEER<sub>12/7°C</sub> & SEPR<sub>12/7°C</sub>** Values calculated in accordance with EN14825:2022  
**SEER<sub>23/18°C</sub>** Values calculated in accordance with EN14825:2022  
 IPLV.SI Calculations according to standard performances AHRI 551-591 (SI)  
 (1) Weight shown is a guideline only. Please refer to the unit nameplate  
 (2) In dB ref=10<sup>-12</sup> W, (A) weighting. Declared dualnumber noise emission values in accordance with ISO 4871 (with an associated uncertainty of +/-3dB(A)). Measured in accordance with ISO 9614-1 and certified by Eurovent.  
 (3) In dB ref 20μPa, (A) weighting. Declared dualnumber noise emission values in accordance with ISO 4871 (with an associated uncertainty of +/-3dB(A)). For information, calculated from the sound power level Lw(A).



Eurovent certified values

## PHYSICAL DATA, 30RB / 30RQ UNITS

		30RB 26	30RB 33	30RB 40	30RQ 26	30RQ 33	30RQ 40
<b>Dimensions</b>							
Length	mm	1002					
Depth	mm	824					
Height	mm	1790					
<b>Compressor</b>		One hermetic scroll compressor					
<b>Refrigerant charge R-410A</b>	kg	5,8	8,6	8,8	7,6	9,5	9,8
	teqCO <sub>2</sub>	12,1	18,0	18,4	15,9	19,8	20,5
<b>Control</b>		Pro-Dialog+					
<b>Fans</b>		One twin-speed axial fan, 7 blades					
Diameter	mm	710					
Air flow	l/s	3530					
Speed	r/s	15					
<b>Water heat exchanger</b>		Plate heat exchanger, maximum operating pressure 1000 kPa					
<b>Water volume</b>	l	2,28	2,85	3,8	2,28	2,85	3,8
<b>Air heat exchanger</b>		Copper tubes and aluminum fins					
Pipe diameter	in	3/8	3/8	3/8	3/8	3/8	3/8
Number of rows		2	3	3	2,5	3	3
Number of pipes per row		60	60	60	60	60	60
Fin spacing	mm	1,69	1,69	1,69	1,69	1,69	1,69
<b>Standard unit</b>							
Water connections (MPT gas)	in	1-1/4					
<b>Unit with hydraulic module</b>		Pump, screen filter, expansion tank, flow switch, pressure gauge, automatic air purge valve, relief valve					
Pump		One single-speed pump, maximum water-side operating pressure 400 kPa					
Expansion tank capacity	l	8					
Entering water connection	in	1-1/4					
Leaving water connection	in	1-1/4					
Nominal operating current	A	2,4	2,6	2,8	2,4	2,6	2,8
<b>Chassis paint colour</b>		RAL 7035					

## ELECTRICAL DATA, 30RB/RQ UNITS

30RB/RQ		026	033	040
<b>Power circuit</b>				
Nominal power supply	V-ph-Hz	400-3+N-50 (power supply option C) or 400-3-50 (power supply option D)		400-3-50 (STD - no option)
Voltage range	V	340-460		360-440
<b>Control circuit supply</b>				
24 V via internal transformer				
<b>Maximum start-up current (Un)<sup>(1)</sup></b>	A	118	118	176
<b>Unit power factor at nominal capacity<sup>(2)</sup></b>		0,77	0,81	0,9
<b>Maximum operating power input<sup>(2)</sup></b>	kW	11	13,8	17,5
<b>Nominal current drawn<sup>(3)</sup></b>	A	16	17	25
<b>Maximum operating current draw (Un)<sup>(4)</sup></b>	A	20	24	30
<b>Maximum operating current draw (Un-15%)<sup>(5)</sup></b>	A	23	27	36

(1) Maximum instantaneous start-up current (locked rotor current of the compressor).

(2) Power input, compressors and fans, at the unit operating limits (saturated suction temperature 10°C, saturated condensing temperature 65°C) and nominal voltage of 400 V (data given on the unit nameplate).

(3) Standardised Eurovent conditions: Water heat exchanger entering/leaving water temperature 12°C/7°C, outside air temperature 35°C.

(4) Maximum unit operating current at maximum unit power input and 400 V (values given on the unit nameplate).

(5) Maximum unit operating current at maximum unit power input and 340-460V for sizes 026 to 033 or 360-440V for size 040.

## DIMENSIONS/CLEARANCES

### 30RB/RQ 026-040

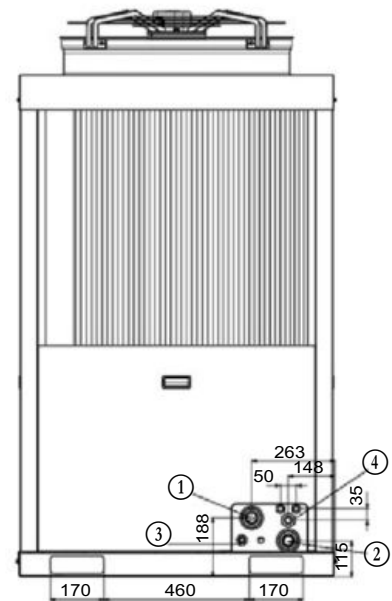
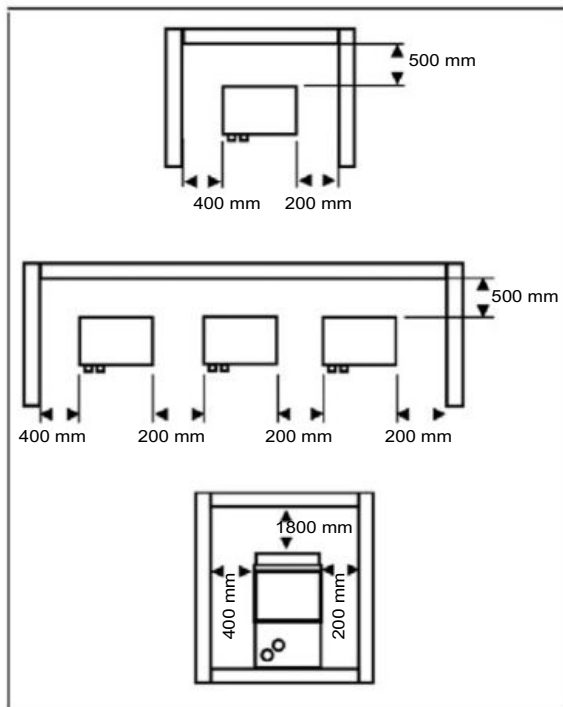
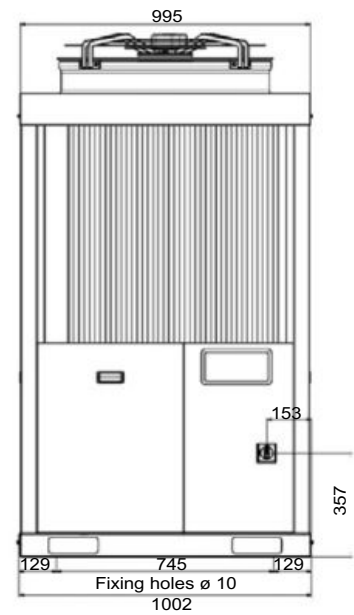
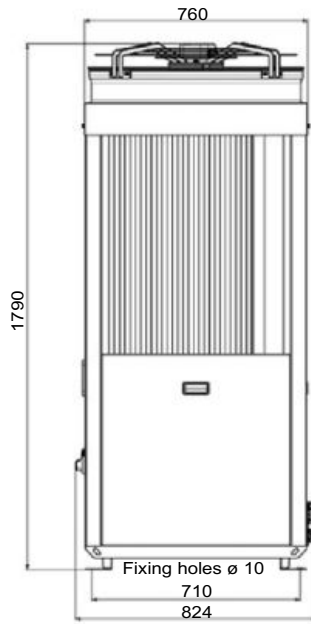
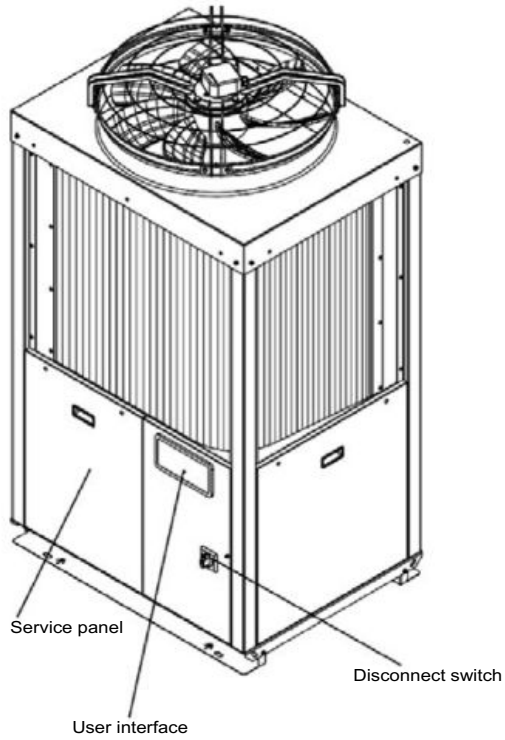

**Legend**

All dimensions are in mm

- ① Water inlet
- ② Water outlet
- ③ Water fill kit connection (option)
- ④ Power connections





## AIR-COOLED SCROLL CHILLERS WITH GREENSPEED® INTELLIGENCE



Low environmental impact

High full and part load efficiency

Compact and simple to install

Low refrigerant charge

Superior reliability

# 30RB 040R-160R

Cooling capacity 40-160 kW

AquaSnap® heat pumps and liquid chillers are the best solution for commercial and industrial applications where installers, engineering and design departments and building owners require reduced installation costs, optimal performances and maximum quality.

- AquaSnap® (30RB-30RQ) is a compact all-in-one package optimised for applications which require reduced investment and installation costs (low CapEx).
- The large options panel allows for configurations that suit user requirements.
- Optional variable-speed fans and pumps with Carrier Greenspeed® intelligence control logic make this a product which is optimised for part load applications where a high SEER, SEPR, SCOP or IPLV value is required.

In this configuration, AquaSnap® provides premium part load efficiency to reduce maintenance costs over the lifespan of the chiller. In addition, the sound levels achieved under the part load conditions are particularly low. Besides operating efficiently and quietly, the AquaSnap® range with Greenspeed® intelligence operates from -20 °C up to +46 °C as standard.



CARRIER participates in the ECP programme for LCP-HP  
Check ongoing validity of certificate:  
[www.eurovent-certification.com](http://www.eurovent-certification.com)

\* The availability of sizes and options depends on the country. Please contact your local commercial dealer for more information.

## R-32: THE BEST SOLUTION FOR SCROLL LIQUID CHILLERS AND HEAT PUMPS

Carrier was the first to introduce the R-1234ze HFO with ultra-low GWP in screw chillers, as far back as early 2016. Today, having examined its main properties, Carrier has chosen R-32 refrigerant to replace high-GWP R-410A refrigerant in its Scroll liquid chillers and heat pumps, for its lower environmental impact, high energy efficiency, good availability and ease of use.

R-32 is currently the ideal refrigeration solution for units equipped with Scroll compressors. By using R-32 refrigerants, Carrier has reduced the carbon footprint of its AquaSnap® range of liquid chillers and heat pumps by 77%. This is the result of a much lower GWP and a significant reduction in the system's cooling charge compared to the previous generation that used R-410A.

R-32 is also the right choice economically, reducing the locally imposed tax burden on HFCs based on the CO<sub>2</sub> impact.



**CO<sub>2</sub> FOOTPRINT**  
REDUCED BY UP TO **77%**

### Lower environmental impact (77% compared to R410A)

- R-32 has zero ozone depletion potential (ODP)
- The Global Warming Potential (GWP) of R-32 is 675, i.e. approximately one third of that of R-410A (PRP 2088)
- The AquaSnap® R-32 cooling charge is reduced by 30% compared to the previous version using R-410A<sup>(1)</sup>
- The carbon footprint of AquaSnap® R-32 is therefore 473 (675 x 0.7), i.e. 77% lower than the version using R-410A (2088 x 1)

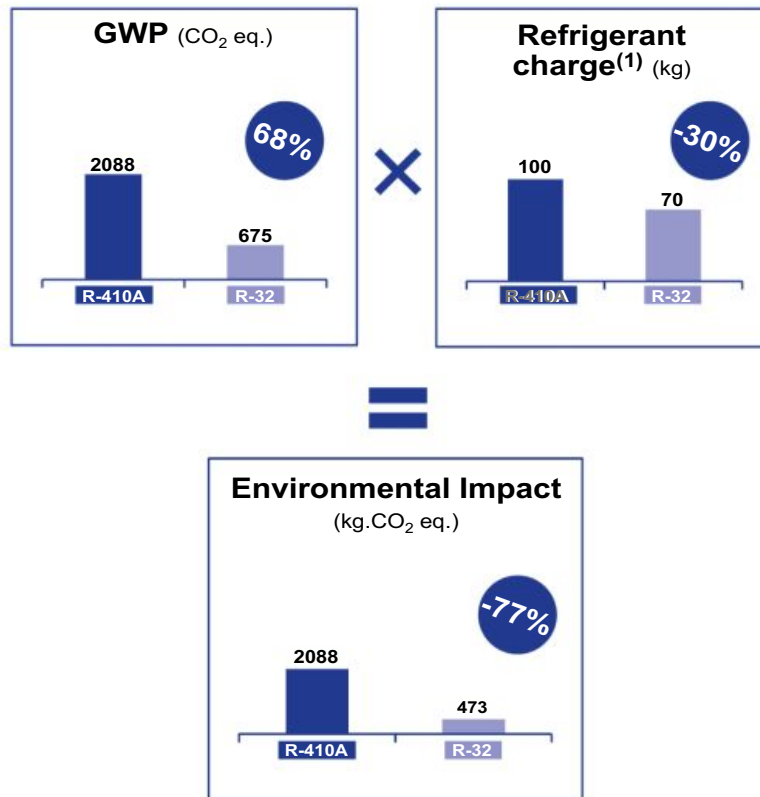

(1) Reduced refrigerant charge in Carrier heat pumps thanks to the use of R-32 and a new coil design.

# R-32: THE BEST SOLUTION FOR SCROLL LIQUID CHILLERS AND HEAT PUMPS



**SEER** up to **+8%**  
**SCOP** up to **+5%**

## High energy efficiency

The seasonal efficiency of AquaSnap® R-32 is higher than that of the previous R-410A version by:

- +8% on average in cooling mode
- +5% on average in heating mode

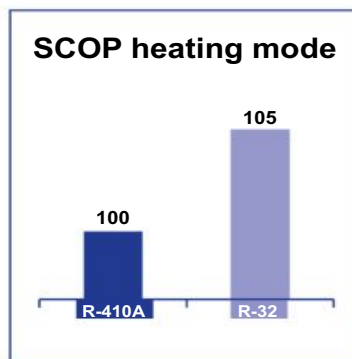
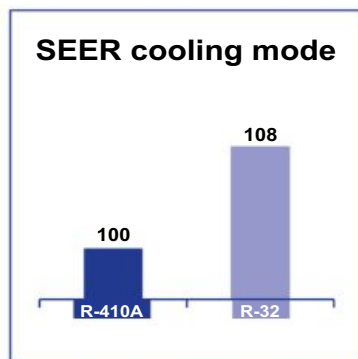

## SIMPLICITY

### Widely available and easy to use

More than 50 million R-32 air conditioning units are in circulation on the global market. While R-32 has been used for some time in residential and commercial air conditioning units, most manufacturers now use R-32 in VRF systems, liquid chillers and heat pumps, which means R-32 is widely available around the world.

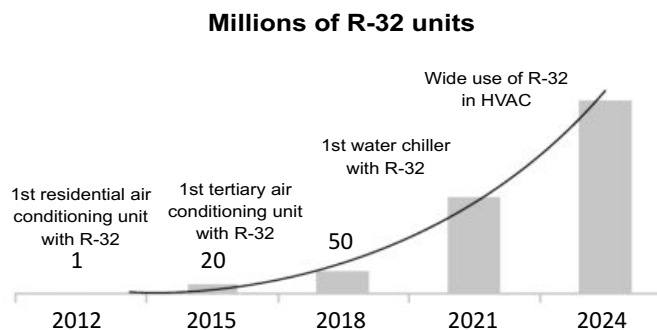

R-32 has been widely available for over 15 years, as it comprises 50% of the composition of R-410A.

R-32 is easy to use: It is a pure refrigerant, therefore it is not necessary to drain the entire circuit in the event of a leak.



## SAFETY

R-32 is an A2L classified refrigerant thanks to its low flammability.

- **No specific safety requirements** for transporting chillers by road or for outdoor installation.
- The service tools must be **certified for A2L** refrigerants in accordance with standard ISO 817 or EN378.
- Service technicians **must be qualified for brazing components** on PED 2 fluid units.



## AQUASNAP® - CUSTOMER BENEFITS

### Outstanding performance

Equipped with variable-speed fans (VSD or EC optional) and optional variable-speed pumps, Carrier's AquaSnap® 30RB/RQ range with Greenspeed® intelligence automatically adjusts the cooling capacity and water flow to perfectly adapt to the building's requirements or load variations. The result is optimum operation at both full load and part load. The 30RB/RQ offers energy efficiency up to 10% higher than the previous range with the same or a smaller footprint.

The range is already fully compliant with current Ecodesign regulations.



SEER up to 4,62  
SCOP up to 4,00

### Extensive field of application

The AquaSnap® range is suitable for a very wide range of applications from tertiary to industrial processes. The range can operate at outdoor temperatures from -20 °C to +44 °C (Optional 46 °C) and with negative water temperatures (-8 °C). From high-end office buildings and hotels to healthcare facilities, data centers and industrial projects, AquaSnap® 30RB/RQ units meets the most demanding expectations in terms of energy efficiency and savings, whatever the climate or application.

### Easy installation & maintenance

Thanks to the variable-speed pumps, automatic adjustment of the nominal water flow rate via electronic control and automatic measurement of the unit's energy performance under real conditions, pumping energy consumption is reduced by almost two thirds: These new features guarantee peace of mind for installers and maintenance companies and lower energy bills for users.



BETWEEN  
**-20 °C**  
and **46 °C**



Pumping energy  
reduced  
by up to **66%**

## AQUASNAP® - CUSTOMER BENEFITS

AquaSnap® liquid chillers and heat pumps are designed to meet current and future Ecodesign and F-Gas European regulation requirements in terms of energy efficiency and reduced CO<sub>2</sub> emissions. They use the best technologies available today:

- Reduced refrigerant charge of non-ozone depleting R-32A refrigerant with low GWP,
- Scroll compressors,
- Greenspeed® variable-speed fans option,
- NOVATION™ micro-channel heat exchangers with a new aluminium alloy (30RB),
- Brazed-plate heat exchangers with reduced pressure drops,
- Self-regulating microprocessor control with Greenspeed® intelligence,
- Colour touch screen with web connectivity options.

AquaSnap® can be equipped with a built-in hydraulic module, limiting the installation to conventional operations such as connection of the power supply and the supply and return piping (plug & play), according to the dimensions of the standard unit.

Recommended by Carrier, the AquaSnap® can be equipped with one or two Greenspeed® variable-speed pumps to significantly reduce energy costs linked to pumping (reduction of more than two-thirds), ensure optimum water flow rate control, and improve overall system reliability.



### Very economical operation

- High unit full- and part-load energy efficiency and efficient design of the water side:
  - SEER<sub>12/7 °C</sub> up to 4.6 in line with the new Ecodesign 2016/2281 regulation.
  - SCOP<sub>35 °C</sub> up to 3.84
  - Multiple scroll compressors equipped with a high-efficiency motor which can exactly match the cooling capacity to the load required
  - Electronic expansion valve enabling operation at a lower condensing pressure and improved use of the evaporator heat transfer area (superheat control)
  - Condenser with high-efficiency NOVATION™ (30RB) aluminium micro-channel heat exchangers and Greenspeed® variable-speed fans (optional)
  - Low pressure drop brazed plate heat exchangers (< 45 kPa under Eurovent conditions).
- Specific control functions to reduce unit cooling energy use during occupied and unoccupied periods:
  - Internal timer: Switches the chiller on/off and controls operation at a second setpoint,
  - Setpoint automatically offset based on the outdoor air temperature or room air temperature (via an option),
  - Floating high pressure (HP) management,
  - Variable-speed fan control,
  - Cooling demand limitation.

Refer to the control chapter for more information.

- Greenspeed® variable-speed pump to reduce pumping energy consumption by up to two-thirds (option recommended by Carrier):
  - Eliminate energy losses through the water flow rate control valve by electronically setting the nominal water flow rate,
  - Save energy during stand-by periods or part-load operation by automatically reducing the water pump speed. The energy consumption of the pump motor varies according to the cube of the speed, so that a reduction in speed of just 40% can reduce energy consumption by 80%,
  - Improved unit part-load performance (increased SEER/SCOP value with variable water flow according to standard EN14825).

Refer to the hydraulic option chapter for more information.

- Extra energy savings through multiple options:
  - Carrier dry cooler Free cooling mode management,
  - Partial heat recovery.
- Reduced maintenance costs:
  - Fast diagnosis of possible incidents and their history via the control,
  - Programmable maintenance alert,
  - Programmable F-Gas leak monitoring alert

## AQUASNAP® - CUSTOMER BENEFITS

### Low noise level

- Condenser with fixed-speed fans (30RB-30RQ):
  - Optional low-speed and variable-speed fans (700 rpm) and compressor enclosure to reduce full-load noise level by up to -9 dB(A)
  - Low noise 6th generation Flying bird™ fans, made of a composite material (Carrier patent)
  - Rigid fan installation for reduced noise (Carrier patent).
- Condenser with Greenspeed® variable-speed fans (optional) recommended by Carrier for even quieter operation:
  - Optional factory setting of the fan at low speed, with compressor enclosure to reduce full-load noise level by up to -9 dB(A),
  - Exceptional acoustic signature during part-load operation through smooth fan speed variation.
- Specific control functions or features to reduce noise level during the night or unoccupied periods:
  - Night-time sound control with cooling capacity and fan speed limitation,
  - Low-noise scroll compressors with low vibration level,
  - The compressor assembly is installed on an independent chassis and supported by flexible anti-vibration mountings,
  - Dynamic suction and discharge piping support, minimising vibration transmission (Carrier patent),
  - Acoustic compressor enclosure, reducing radiated noise emissions (optional).

### Quick and easy installation

- Compact design:
  - AquaSnap® units are designed with compact dimensions for easy installation.
  - With a length of approximately 4.8 m for 550 kW and a width of 2.25 m, the units require minimal floor space.
- Integrated hydraulic module (option):
  - Low- or high-pressure water pump (as required),
  - Single or dual pump (as required) with runtime balancing and automatic changeover to the back-up pump if a fault develops
  - Built-in variable-speed pumps with automatic nominal water flow adjustment via electronic control on the user display.
  - Water filter protects the water pump against circulating debris,
  - Pressure sensors for direct numerical display of the water flow rate and water pressures,
  - Thermal insulation and frost protection down to -20 °C, using a heater (option),
  - High-capacity membrane expansion tank (option).
- Built-in hydraulic module with Greenspeed® variable-speed pump (option recommended by Carrier):
  - Quick and easy electronic setting of the nominal water flow rate when the unit is commissioned, thus eliminating the need to adjust the water flow rate control valve,
  - Automatic control of the pump speed based on constant speed, constant pressure difference or constant temperature difference.

- Simplified electrical connections
  - A single power supply point without neutral,
  - Main disconnect switch with high trip capacity,
  - 24 V control circuit using an integrated transformer.
- Simplified hydraulic connections:
  - Victaulic type couplings on the exchanger;
  - Clearly identified and practical reference marks for entering and leaving water connections;
- Fast unit commissioning
  - Systematic factory test before shipment,
  - Quick-test function for step-by-step verification of the sensors, electrical components and motors.

### Reduced installation costs

- Optional Greenspeed® variable-speed pump with hydraulic module (option recommended by Carrier)
  - Cut costs relating to the water flow control valve,
  - The design of the water system with variable primary flow (VPF) can provide significant installation cost savings compared with traditional constant primary systems with variable secondary circuits; elimination of the secondary distribution pump, etc.
  - Water system design with fan coils fitted with 2-way valves instead of 3-way valves.
- No buffer tank required thanks to Carrier's advanced control algorithm
  - Minimum water loop volume reduced to 2.5 l/kW.

## AQUASNAP® - CUSTOMER BENEFITS

### Environmentally responsible

AquaSnap® liquid chillers with Greenspeed® intelligence (With optional variable-speed fans and pumps) are a boost for green cities and contribute to a sustainable future. Combining a refrigerant charge up to 30% lower, with R-32 refrigerant with a GWP 70% lower than that of the previous version using R410A, and exceptional energy efficiency, this chiller significantly reduces energy consumption while reducing carbon dioxide emissions throughout its life cycle.

- Pumping energy consumption can be reduced by up to 2/3 using Greenspeed® variable-speed pumps,
- 40% lower refrigerant charge: The micro-channel technology used for condenser coils optimises heat transfer while minimising the refrigerant volume.
- Sealed refrigerant circuits:
  - Leaks are eliminated thanks to the absence of capillary tubes and the use of flare connections,
  - Verification of pressure transducers and temperature sensors without transferring refrigerant charge,
  - Discharge line shut-off valve and liquid line service valve for simplified maintenance,
  - Qualified Carrier maintenance personnel to provide refrigerant servicing,
  - ISO 14001 production plant.

### Superior reliability

- State-of-the-art concept
  - Two self-contained refrigerant circuits; the second one automatically takes over if the first one develops a fault, maintaining partial cooling in all circumstances,
  - All compressor components are easily accessible on site, minimising downtime,
  - All-aluminium NOVATION™ micro-channel heat exchanger (MCHE) (30RB) with higher corrosion resistance than a conventional coil. The all-aluminium construction eliminates the formation of galvanic currents between aluminium and copper which can corrode the coil in saline or corrosive atmospheres,
  - V-coil design to protect the coils against hail impact,
  - Optional Enviro-shield® anti-corrosion coil coating for use in moderately corrosive environments. Coating applied through conversion process which modifies the surface of the aluminium producing a coating that is integral to the coil. Immersion in a bath to ensure 100% coverage. No heat transfer variation, tested for 4000 hours in salt spray per ASTM B117,
  - Optional Super Enviro-shield® anti-corrosion coil coating for use in extremely corrosive environments. Extremely durable and flexible epoxy polymer coating applied on micro-channel heat exchangers by electro coating process with a final UV protective topcoat. Minimal heat transfer variation, tested for 6000 hours in salt spray per ASTM B117, superior impact resistance per ASTM D2794
  - Electronic flow switch. Auto-setting according to cooler size and fluid type.

- Self-regulating control
  - The control algorithm prevents excessive compressor cycling and reduces the quantity of water in the water loop (Carrier patent),
  - Automatic compressor unloading in case of abnormally high condensing pressure,
  - Automatic fan speed adjustment in case of coil fouling (30RB models),
  - Smooth fan start to increase unit lifetime (optionals include variable-speed fans).
- Exceptional endurance tests:
  - To design critical components and sub-assemblies to minimise the risk of failure on site, Carrier uses specialised laboratories and advanced dynamic simulation tools.
  - To ensure that the units reach customer sites in the same condition as they are when tested in the factory, Carrier tests the machine behaviour during transportation over 250 km. The road test is based on a military standard and is the equivalent to 5000 km by truck on a normal road.
  - To guarantee the coil corrosion resistance, salt spray corrosion resistance tests are performed in the group's laboratory.
  - In addition, to maintain the unit's performance throughout its operating life whilst minimising maintenance costs, end users can access the "Connected Services" remote monitoring service.

### Designed to support Green Building Design

A green building is a building that is environmentally sustainable and is designed, constructed and operated to minimise the total impact on the environment.

The resulting building will be economical to operate, offer increased comfort and create a healthier environment for the people who live and work there, increasing productivity.

The air conditioning system can use between 30 and 40% of the annual building energy consumption. Choosing the right air conditioning system is one of the main considerations when designing a green building. For buildings with a load that varies throughout the year, the AquaSnap® 30RB/30RQ unit offers a solution to this important challenge.

A number of green building certification programmes exist in the market and offer third-party assessment of green building measures for a wide variety of building types.

The following example looks at how Carrier's new AquaSnap® range helps customers affected by LEED® building certification.



## AQUASNAP® - CUSTOMER BENEFITS

### Energy saving certificate

The AquaSnap® 30RB/RQ unit is eligible for energy saving certificates in France (CEE) in comfort, industrial and agriculture applications:

- Floating High pressure control (by modulating the air flow through fan activation and speed)
- Floating Low pressure control
- Variable speed on asynchronous fan motor (optional)
- Variable speed on asynchronous pump motor (optional)
- Partial heat recovery (option)

For more details about financial incentives in France, please refer to the "CEE product sheet".

### The AquaSnap® range and LEED® certification

The LEED® (Leadership in Energy and Environmental Design) green building certification programme is a major initiative set up to assess the design, construction and operation of green buildings with points assigned in seven credit categories:

- Sustainable Sites (SS),
- Water efficiency (WE),
- Energy and atmosphere (EA),
- Materials and resources (MR),
- Indoor environmental quality (IEQ),
- Innovation in design (ID),
- Regional Priority (RP).

There are a number of different LEED® products.

While the strategies and categories assessed remain the same, the distribution of points varies depending on the type of building and the requirements of the application, based on whether it is a new construction, school, core & shell, retail or healthcare.

All programmes now use the same point scale:

#### 110 LEED® points available

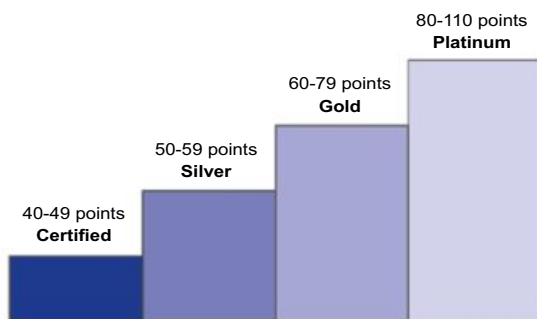

The majority of credits in LEED® rating systems are performance-based and achieving them is dependent on the impact of each component or sub-system on the building as a whole.

While the LEED® green building certification programmes do not certify products or services, choosing the right products, systems or service programmes is critical to obtaining LEED® certification for a registered project, because the right products or service programmes can help meet the goals of green construction and ongoing operation and maintenance.

The choice of heating, ventilation and air conditioning (HVAC) products in particular can have a significant impact on LEED® certification, as the HVAC system directly impacts two categories that together influence 40% of the available points.

### EcoPassport®

The PEP ecopassport® programme provides an international reference framework for procedures enabling manufacturers to report the environmental specifications of their products in the form of an environmental claim known as a Product Environmental Profile (PEP).

The PEP ecopassport® programme guarantees that PEPs are correctly drawn up, verified and reported in line with the requirements of the ISO 14025 and IEC/PAS 62545 standards.

The Life Cycle Analysis (LCA) PEP is the environmental identity card for an item of equipment which details the environmental impacts of the product during its life cycle according to eight mandatory indicators:

1. Global Warming Potential,
2. Impact on the ozone layer,
3. Acidification of soil and water,
4. Eutrophication of water,
5. Photochemical ozone creation,
6. Abiotic resource depletion,
7. Fresh water consumption,
8. Total use of primary energy during the life cycle.

Products with certified environmental profiles are used to support methods to assess building sustainability such as BREEAM, LEED. BREEAM, LEED gives additional recognition for materials with robust environmental product declaration types using manufacturer data.

Carrier is the first HVAC manufacturer to provide PEPs for liquid chillers and heat pumps with, not only the 8 mandatory indicators, but all 27 indicators.

The AquaSnap® PEP can be downloaded from the PEP ecopassport® website: <http://www.pep-ecopassport.org/fr/>

## AQUASNAP® - CUSTOMER BENEFITS

### Designed to support Green Building Design

#### Overview of LEED® for new construction and major renovations

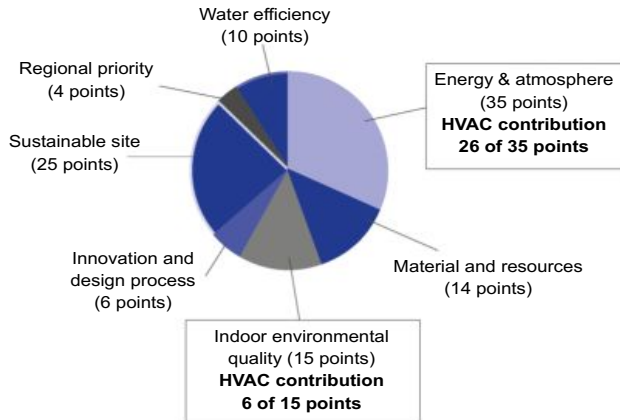

The new AquaSnap® units from Carrier can help building owners to earn LEED® points in particular in the Energy & Atmosphere (EA) credit category and help address the following prerequisites and credit requirements:

- EA prerequisite 2: Minimum energy performance
- 30RB/RQ units exceed the energy efficiency requirements of ASHRAE 90.1-2007; therefore they satisfy the prerequisites.
- EA prerequisite 3: Fundamental refrigerant management  
30RB/RQ units do not use chlorofluorocarbon (CFC) refrigerants, thus satisfying the prerequisites.
- EA credit 1: Optimise energy performance (1 to 19 points)  
Points for this credit are assigned depending on the energy cost reduction virtually achievable by the new building, compared to ASHRAE 90.1-2007 reference. 30RB/RQ units, which are designed for high performance especially during part load operation, help to reduce the building's energy consumption and therefore to gain points for this credit. In addition, the Carrier HAP (Hourly Analyses Program) can be used to analyse energy. It meets the modelling requirements for this credit and produces reports which can be easily transferred to LEED® charts.
- EA credit 4: Enhanced refrigerant management (2 points)  
With this credit, LEED® awards systems that minimise the installed system's Ozone Depletion Potential (ODP) and Global Warming Potential (GWP). 30RB/30RQ units use a reduced R-32 charge and therefore help satisfy the requirements of this LEED® credit.

**NOTE:** This section describes the prerequisites and credit requirements in LEED® for New Construction and is directly related to the 30RB/30RQ units. Other prerequisites and credit requirements are not directly and purely related to the air-conditioning unit itself, but more to the control of the HVAC system as a whole.

i-Vu®, Carrier's open control system, has features that can be valuable for:

- EA prerequisite 1: fundamental commissioning of energy management systems;
- EA credit 3: enhanced commissioning (2 points);
- EA credit 5: measurements and verification (3 points).

**NOTE:** Products are not reviewed or certified under LEED®. LEED® credit requirements cover the performance of materials in aggregate, not the performance of individual products or brands. For more information on LEED®, visit [www.usgbc.org](http://www.usgbc.org).

## 30RB - 30RQ TECHNICAL OVERVIEW



### SIXTH GENERATION FLYING BIRD™ FIXED-SPEED FANS

- Exclusive Carrier design
- Fan blade design inspired by nature
- High efficiency version with AC motor technology
- Variable speed option:
  - Patented algorithm to control the fan speed.
  - Dedicated variator or EC type motor.
  - Night mode operation.



### NOVATION™ SECOND GENERATION MICRO CHANNEL HEAT EXCHANGERS (30RB)

- Increased reliability with new aluminium alloy
- Significantly reduces the refrigerant charge (-40% compared to Cu/Al coils)
- Improved thermal performance, improved efficiency and lower pressure drops compared to Cu/Al coils
- Enviro-Shield® coating for mildly corrosive environments
- Super Enviro-Shield® coating for highly corrosive environments (industrial or marine applications)
- Easy cleaning with high pressure air or water washer



### SmartVu™ CONTROL

- 6 languages available
- 4.3" user-friendly touch screen
- All main parameters displayed on one screen
- Direct access to the unit's technical drawings and the main service documents
- Very easy online monitoring
- Easy and secure access to unit parameters
- Optional Bacnet, J-Bus or LON communication interfaces



### VARIABLE-SPEED PUMP

- Water flow electronic control and reading
- Automatic protection of the pump against low pressure
- Multiple control options:
  - Constant flow with low speed mode on standby
  - Variable flow based on pressure difference or constant temperature



### SCROLL COMPRESSORS



### REDUCED REFRIGERANT CHARGE



### HIGH-EFFICIENCY BRAZED PLATE HEAT EXCHANGER

- Latest generation asymmetrical type (unit with 2 circuits)
- Low pressure drop

### PUMP SPEED REGULATOR



## TECHNICAL INSIGHTS

### SmartVu™ control

The SmartVu™ control combines intelligence with operating simplicity. The control constantly monitors all machine parameters and precisely manages the operation of compressors, expansion devices, fans and the evaporator water pump for optimum energy efficiency.

The SmartVu™ control features advanced communication technology over Ethernet (IP) and a user-friendly and intuitive user interface with 4.3 inch colour touch screen.

- Energy management configuration
  - Internal timer: Controls chiller on/off times and operation at a second setpoint,
  - Setpoint offset based on the outdoor air temperature,
  - Master/slave control of two chillers operating in parallel with runtime balancing and automatic changeover in case of a unit fault,
  - For further energy savings, the AquaSnap® can be monitored remotely by Carrier experts for energy consumption diagnosis and optimisation.
- Integrated features
  - Night mode: Capacity and fan speed limitation for reduced noise level,
  - With hydraulic module: Water pressure display and water flow rate calculation.
- Advanced communication features
  - Easy, high-speed communication technology over Ethernet (IP) to a centralised building management system,
  - Access to multiple unit parameters.
- Maintenance functions
  - F-Gas regulation leak check reminder alert,
  - Maintenance alert can be configured to days, months or hours of operation,
  - Storage of maintenance manual, wiring diagram and spare parts list,
  - Display of trend curves for the main values,
  - Management of a fault memory allowing a log of the last 50 incidents to be accessed, with operating readings taken when the fault occurs,
  - Blackbox memory.

- 4.3" SmartVu™ user interface



- Intuitive and user-friendly 4.3" inch touch screen interface,
- Concise and clear information is available in local languages,
- Complete menu, customised for different users (end user, service personnel or Carrier engineers).

### Remote management (standard)

Units with SmartVu™ control can be easily accessed from the internet, using a PC with an Ethernet connection. This makes remote control quick and easy and offers significant advantages for service operations.

The AquaSnap® is equipped with an RS485 serial port that offers multiple remote control, monitoring and diagnostic possibilities. Carrier offers a vast choice of control products, specially designed to control, manage and supervise the operation of an air conditioning system. Please consult your Carrier representative for more information.

The AquaSnap® also communicates with other centralised building management systems via optional communication gateways.

A connection terminal allows the AquaSnap® unit to be remotely controlled by wire:

- Start/stop: Opening of this contact will shut down the unit,
- Dual setpoint: closing of this contact activates a second setpoint (e.g.: unoccupied mode),
- Demand limit: Closing of this contact limits the maximum chiller capacity to a predefined value,
- Operation indication: This volt-free contact indicates that the chiller is operating (cooling load),
- Alarm indication: this volt-free contact indicates the presence of a major fault that has led to the shut-down of one or several refrigerant circuits,
- Setpoint adjustable via 4-20 mA signal.



## OPTIONS

Options	No.	Description	Advantages	AquaSnap 30RB	Aquasnap 30RQ
Corrosion protection, traditional coils	3A	Fins made of pre-treated aluminium (polyurethane and epoxy)	Improved corrosion resistance, recommended for moderate marine and urban environments	-	040-160
Low-temperature brine solution	6B	Low temperature chilled water production down to -8 °C with ethylene glycol and propylene glycol.	Covers specific applications such as ice storage and industrial processes	040-160	040-160
High static fans	12	Unit equipped with high-pressure static variable-speed fans (maximum 200 Pa), each fan being equipped with a connection flange for connection to the ducting system.	Ducted fan discharge, optimised temperature control, based on the operating conditions and system characteristics	040-160	040-160
Return air connection frame	12A	Unit equipped with a connection frame at the heat exchange coil inlet	Facilitates channelling of the air at the unit inlet.	040-080	040-080
Very low noise level	15LS	Acoustic compressor enclosure and low-speed fans	Noise level reduction for sensitive sites	040-160	040-160
High ambient temperature	16	Unit equipped with a higher speed fan	Unit operating range extended to higher ambient temperatures	040-160	040-160
EC fans	17	Unit equipped with EC fans	Improves the unit's energy efficiency	040-160	040-160
Protection grilles	23	Metallic protection grilles	Coil protection against possible impact	040-160	040-160
Air filter and return air connection frame	23B	Unit equipped with a connection frame at the heat exchange coil inlet and washable G2 efficiency filter in accordance with EN 779	Facilitates channelling of the air at the unit inlet and protects the air exchanger against pollution	040-080	040-080
Soft starter per compressor	25	Electronic starter on each compressor	Reduced start-up current	040-160	040-160
Winter operation down to -20 °C	28	Fan speed control via frequency converter	Stable unit operation when the outdoor air temperature is between -10 °C and -20 °C	040-160	040-160
Water exchanger frost protection	41	Electric heater on the water type heat exchanger and the water duct	Water type heat exchanger module frost protection for an outdoor air temperature between 0 °C and -20 °C	040-160	040-160
Hydronic module antifreeze protection	42	Electric heater on the hydronic module	Antifreeze protection of the hydronic module for outdoor temperatures down to -20 °C	040-160	040-160
Exchanger and hydronic module antifreeze protection	42B	Electric heaters on the water heat exchanger, water pipes, hydronic module, optional expansion tank and buffer tank	Water type heat exchanger and hydronic module frost protection down to an outdoor air temperature of -20 °C	040-160	040-160
Partial heat recovery	49	Unit equipped with one desuperheater on each refrigerant circuit	Simultaneous production of free high-temperature hot water and chilled water production (or hot water for the heat pump)	040-160	040-160
Master/slave operation	58	Unit equipped with supplementary water outlet temperature sensor kit (to be field installed) allowing master/slave operation of two units connected in parallel	Optimised operation of two units connected in parallel operation with runtime balancing	040-160	040-160
Evaporator single HP pump	116R	High-pressure fixed-speed water pump, drain valve, air vent and pressure sensors. (optional expansion vessel and built-in safety hydraulic components available)	Quick and easy installation (plug & play)	040-160	040-160
Evaporator dual HP pump	116S	Dual high-pressure fixed-speed water pump, electronic water flow control, pressure sensors. (optional expansion tank and built-in hydraulic safety components available)	Quick and easy installation (plug & play)	040-160	040-160
Variable-speed single HP pump	116V	Single low-pressure water pump, water filter, electronic water flow control, pressure sensors. Multiple variable water flow control options (optional expansion tank and built-in hydraulic safety components available)	Quick and easy installation (plug & play), significant pumping energy cost savings (up to 2/3), tighter water flow control.	040-160	040-160
Variable-speed dual high-pressure pump	116W	Dual high-pressure water pump with speed regulator, pressure sensors. Multiple water flow rate control options. For more details, refer to the dedicated chapter.	Quick and easy installation (plug & play), significant pumping energy cost savings (more than two-thirds), tighter water flow control, improved system reliability	040-160	040-160
Variable-speed single LP pump	116X	Single low-pressure water pump with speed regulator, pressure sensors. Multiple water flow rate control options. (optional expansion vessel and built-in hydraulic safety components available)	Quick and easy installation (plug & play), significant pumping energy cost savings (up to 2/3), tighter water flow control.	040-160	040-160

## OPTIONS

Options	No.	Description	Advantages	AquaSnap 30RB	Aquasnap 30RQ
Variable-speed dual LP pump	116Y	Evaporator hydronic module equipped with a variable-speed low-pressure pump, a drain valve, an air vent and pressure sensors. For more details, refer to the dedicated chapter (expansion tank not included; option with built-in hydraulic safety components available)	Quick and easy installation (plug & play), significant pumping energy cost savings (more than two-thirds), tighter water flow control, improved system reliability	040-160	040-160
Evaporator single LP pump	116T	Single low-pressure fixed-speed water pump, electronic water flow control, pressure sensors. (optional expansion tank and built-in hydraulic safety components available)	Quick and easy installation (plug & play)	040-160	040-160
LP dual-pump hydronic module	116U	Dual low pressure water pump, water filter, electronic water flow control, pressure sensors. For more details, refer to the dedicated chapter (expansion tank not included; option with built-in hydraulic safety components)	Quick and easy installation (plug & play)	040-160	040-160
Heating Optimized	119D	Specific configuration to optimized heating mode	Enlarge operating map in heating mode , and increase energetics performances (COP/SCOP)	-	040-160
Lon gateway	148D	Two-directional communication board complying with Lon Talk protocol	Connects the unit by communication bus to a building management system	040-160	040-160
Bacnet over IP	149	Two-directional high-speed communication using BACnet protocol over Ethernet network (IP)	Easy and high-speed connection by Ethernet line to a BMS. Allows access to multiple unit parameters	040-160	040-160
ModBus over IP and RS485 communication gateway	149B	Two-directional high-speed communication using the ModBus over Ethernet network (IP) protocol	Easy, quick connection via Ethernet line to a building technical management system. Allows access to several unit parameters.	040-160	040-160
External boiler management	156A	Control board factory-installed on the unit to control a boiler	Extended remote control capabilities to a boiler on/off command. Permits easy control of a basic heating system	-	040-160
Electric heaters management	156B	Control board factory-installed on the unit with additional inputs/outputs in order to manage up to 4 external heating stages (electrical heaters...)	Extended remote control capabilities to up to 4 electric heaters. Permits easy control of a basic heating system	-	040-160
Input contact for Refrigerant leak detection	159	0-10 V signal to report any refrigerant leakage in the unit directly on the controller (the leak detector itself must be supplied by the customer)	Immediate customer notification of refrigerant losses to the atmosphere, allowing timely corrective actions	040-160	040-160
Refrigerant leak detector	159C	Unit equipped with refrigerant leak detector	Immediate customer notification of refrigerant losses to the atmosphere, allowing timely corrective actions	040-160	040-160
Compliance with Russian regulations	199	EAC certification	Compliance with Russian regulations	040-160	040-160
Insulation of the evaporator inlet/outlet refrigerant lines	256	Thermal insulation of the evaporator inlet/outlet refrigerant lines, with flexible and UV-resistant insulation	Prevents condensation on the evaporator inlet/outlet refrigerant lines	040-160	040-160
Enviro-Shield anti-corrosion protection	262	Coating applied using a conversion process which modifies the surface of the aluminium producing a coating that is integral to the coil. Complete immersion in a bath to ensure 100% coverage. Minimal heat transfer variation, tested to withstand more than 4000 hours of salt spray as per ASTM B117	Improved corrosion resistance, recommended for use in moderately corrosive environments	040-160	-
Super Enviro-Shield anti-corrosion protection	263	Extremely durable and flexible epoxy polymer coating applied by electro coating process, final UV protective topcoat. Minimal heat transfer variation, tested to withstand 6000 hours of constant neutral salt spray as per ASTM B117, improved impact resistance as per ASTM D2794	Improved corrosion resistance, recommended for use in extremely corrosive environments	040-160	-
Evaporator screw connection sleeves kit	264	Evaporator inlet/outlet screw connection sleeves	Allows unit connection to a screw connector	040-160	040-160
Evaporator sleeve kit (to be welded)	266	Victaulic piping connections with welded joints	Easy installation	040-160	040-160

## OPTIONS

Options	No.	Description	Advantages	AquaSnap 30RB	Aquasnap 30RQ
Reinforced ECM filtration for fan VFD	282A	Fan variable frequency drive compliant with IEC 61800-3 class C1	Allows unit installation in domestic residential environment by reducing electromagnetic interferences	040-160	040-160
Reinforced ECM filtration for pump VFD	282B	Pump variable frequency drive compliant with IEC 61800-3 class C1	Allows unit installation in domestic residential environment by reducing electromagnetic interferences	040-160	040-160
Expansion tank	293	6-bar expansion tank integrated in the hydraulic module (requires hydraulic module option)	Easy and fast installation (plug & play), and protection of closed water systems from excessive pressure	040-160	040-160
Water buffer tank module	307	Built-in water buffer tank module	Avoid short cycle on compressors and ensure a stable water in the loop	040-160	040-160
Free cooling mode dry cooler management	313	Control and connections to a free cooling dry cooler 09PE or 09VE fitted with option FC control box	Easy system management, control capacity extended to a dry cooler used in free cooling mode	040-160	-
Compliance with UAE regulations	318	Additional label on the unit with rated power input, rated current and EER in accordance with AHRI 550/590	Compliance with ESMA standard UAE 5010-5:2016.	040-160	-
Compliance with Qatar regulations	319	Specific name plate on the unit with 415 V +/-6% power supply	Compliance with KAHRAMAA regulations in Qatar	040-160	-
Installation or application process outside Europe	326	Specific management of option compatibility	Permits non-standard option compatibility for HVAC application in the EU	040-160	040-160
Compliance with Moroccan regulations	327	Specific regulatory documentation	Compliance with Moroccan regulations	040-160	040-160
Delivery with plastic tarp cover	331	Unit wrapped in a plastic cover and strapped onto a wooden pallet.	Protects against dust and external soiling of the unit during storage and transport.	040-160	040-160

PHYSICAL DATA, SIZES 040R TO 160R

30RB			040R	045R	050R	055R	060R	070R	080R	090R	100R	120R	140R	160R	
<b>Standard unit</b>															
<b>Cooling Full load performances*</b>	CA1	Nominal capacity	kW	41,7	47,3	52,9	56,1	63,6	71,2	81,1	93,4	107	124	140	160
		EER	kW/kW	2,95	2,94	2,93	2,97	2,89	2,90	2,78	2,97	2,83	2,85	2,87	2,76
	CA2	Nominal capacity	kW	54,6	62,7	69,4	74,3	84,6	93,0	103	126	142	162	183	203
		EER	kW/kW	3,60	3,60	3,51	3,61	3,63	3,49	3,22	3,72	3,48	3,40	3,48	3,21
Seasonal energy efficiency**		<b>SEER<sub>12/7 °C</sub> Comfort low temp.</b>	<b>kWh/kWh</b>	<b>4,41</b>	<b>4,47</b>	<b>4,50</b>	<b>4,62</b>	<b>4,41</b>	<b>4,31</b>	<b>4,24</b>	<b>4,38</b>	<b>4,51</b>	<b>4,57</b>	<b>4,46</b>	<b>4,37</b>
		$\eta_{s\ cool\ 12/7 °C}$	%	173	176	177	182	174	169	167	172	177	180	176	172
		<b>SEER<sub>23/18 °C</sub> Comfort medium temp.</b>	<b>kWh/kWh</b>	<b>6,10</b>	<b>6,11</b>	<b>6,06</b>	<b>6,17</b>	<b>5,61</b>	<b>5,72</b>	<b>5,46</b>	<b>5,54</b>	<b>5,78</b>	<b>5,73</b>	<b>5,61</b>	<b>5,34</b>
		<b>SEPR<sub>12/7 °C</sub> Process high temp.</b>	<b>kWh/kWh</b>	<b>6,30</b>	<b>6,23</b>	<b>6,23</b>	<b>6,21</b>	<b>5,92</b>	<b>5,46</b>	<b>5,21</b>	<b>5,45</b>	<b>5,19</b>	<b>5,24</b>	<b>5,37</b>	<b>5,15</b>
		<b>SEPR<sub>-2/-8 °C</sub> Process medium temp.</b>	<b>kWh/kWh</b>	<b>3,59</b>	<b>3,65</b>	<b>3,79</b>	<b>3,89</b>	<b>3,65</b>	<b>3,61</b>	<b>3,67</b>	<b>3,54</b>	<b>3,54</b>	<b>3,74</b>	<b>3,61</b>	<b>3,68</b>
Part Load integrated values	IPLV.SI	kW/kW	4,945	5,025	5,182	5,270	5,369	4,630	4,630	4,904	4,953	4,997	4,707	4,680	
<b>Sound levels</b>															
<b>Standard unit</b>															
Sound power <sup>(1)</sup>		dB(A)	81,5	82,0	83,5	83,5	89,0	89,0	89,0	91,5	91,5	92,0	92,0	92,0	
Sound pressure at 10 m <sup>(2)</sup>		dB(A)	50,0	50,5	52,0	52,0	57,0	57,5	57,0	60,0	59,5	60,0	60,0	60,0	
<b>Unit + option 15LS</b>															
Sound power <sup>(1)</sup>		dB(A)	78,5	79,0	80,0	80,0	80,0	80,0	80,0	83,0	83,0	83,0	83,0	83,0	
Sound pressure at 10 m <sup>(2)</sup>		dB(A)	47,0	47,5	48,5	48,5	48,0	48,5	48,0	51,0	51,0	51,5	51,0	51,0	
<b>Dimensions</b>															
<b>Standard unit</b>															
Length		mm	2109	2109	2109	2109	2109	2109	2109	2275	2275	2275	2275	2275	
Width		mm	1090	1090	1090	1090	1090	1090	1090	2125	2125	2125	2125	2125	
Height		mm	1330	1330	1330	1330	1330	1330	1330	1330	1330	1330	1330	1330	
Unit height (option 12)		mm	1372	1372	1372	1372	1372	1372	1372	1372	1372	1372	1372	1372	
Unit height (option 307)		mm	1931	1931	1931	1931	1931	1931	1931	1931	1931	1931	1931	1931	
Unit height (option 12 + 307)		mm	1973	1973	1973	1973	1973	1973	1973	1973	1973	1973	1973	1973	

\* In accordance with standard EN14511-3:2022.  
 \*\* In accordance with EN14825:2022, average climatic conditions.  
 CA1 Cooling mode conditions: evaporator water inlet/outlet temperature 12 °C/7 °C, outdoor air temperature 35 °C, evaporator fouling factor 0 m<sup>2</sup>. k/W  
 CA2 Cooling mode conditions: evaporator water inlet/outlet temperature 23 °C/18 °C, outdoor air temperature 35 °C, evaporator fouling factor 0 m<sup>2</sup>. k/W  
 **$\eta_{s\ cool\ 12/7 °C}$  & SEER<sub>12/7 °C</sub>** **Values in bold comply with Ecodesign Regulation (EU) No. 2016/2281 for Comfort applications**  
**SEER<sub>23/18 °C</sub>** **Values in bold comply with Ecodesign Regulation (EU) No. 2016/2281 for Comfort applications**  
**SEPR<sub>-2/-8 °C</sub>** **Values in bold comply with Ecodesign Regulation (EU) No. 2015/1095 for HT applications**  
 IPLV.SI Calculated as per AHRI standard 551-591.  
 (1) In dB ref=10<sup>-12</sup> W, (A) weighting. Declared dual-number noise emission value in accordance with ISO 4871 with an uncertainty of +/-3 dB(A). Measured in accordance with ISO 9614-1 and certified by Eurovent.  
 (2) In dB ref 20 µPa, (A) weighting. Declared dual-number noise emission value in accordance with ISO 4871 with an uncertainty of +/-3 dB(A). For information, calculated from the sound power Lw(A).



Eurovent certified values



## PHYSICAL DATA, SIZES 040R TO 160R

30RB		040R	045R	050R	055R	060R	070R	080R	090R	100R	120R	140R	160R
<b>Operating weight <sup>(3)</sup></b>													
Standard unit	kg	408	409	428	428	435	446	454	672	734	743	861	877
Unit + single high-pressure pump option	kg	428	429	448	448	455	466	474	692	754	768	886	902
Unit + dual high-pressure pump option	kg	455	456	475	475	482	493	501	719	781	790	908	924
Unit + single high-pressure pump and buffer tank options	kg	763	765	784	784	791	801	810	1087	1149	1163	1281	1297
Unit + dual high-pressure pump and buffer tank options	kg	790	792	811	811	818	828	837	1114	1176	1185	1303	1319
<b>Compressors</b>		Hermetic Scroll 48,3 r/s											
Circuit A		2	2	2	2	2	2	2	2	3	3	2	2
Circuit B												2	2
No. of power stages		2	2	2	2	2	2	2	2	3	3	4	4
<b>Refrigerant<sup>(3)</sup></b>		R-32 / A2L/ PRP= 675 in accordance with AR4											
Circuit A	kg	3,72	3,92	4,43	4,90	4,70	4,87	4,84	7,75	8,40	9,00	5,00	5,07
	tCO <sub>2</sub> e	2,5	2,6	3,0	3,3	3,2	3,3	3,3	5,2	5,7	6,1	3,4	3,4
Circuit B	kg											5,00	5,07
	tCO <sub>2</sub> e											3,4	3,4
<b>Oil</b>		POE											
Circuit A	l	6,00	6,00	6,60	6,60	6,60	7,20	7,20	7,20	10,80	10,80	7,20	7,20
Circuit B	l											7,20	7,20
<b>Capacity control</b>		SmartVu™											
Minimum capacity	%	50	50	50	50	50	50	50	50	33	33	25	25
<b>PED category</b>		III											
<b>Condenser</b>		All-aluminium micro-channel coils (MCHE)											
<b>Fans</b>		Axial Flying bird™ 6 with rotating shroud											
<b>Standard unit</b>													
Quantity		1	1	1	1	1	1	1	2	2	2	2	2
Maximum total air flow	l/s	3882	3802	4058	3900	5484	5452	5414	10568	10512	10974	10904	10827
Maximum rotation speed	r/s	12	12	12	12	16	16	16	16	16	16	16	16
<b>Evaporator</b>		Direct expansion brazed-plate heat exchanger											
Water volume	l	3,55	4	4,44	4,44	5,18	6,07	6,96	7,4	8,44	9,92	12,69	14,31
Max. water-side operating pressure without hydronic module	kPa	1000	1000	1000	1000	1000	1000	1000	1000	1000	1000	1000	1000
<b>Hydronic module (option)</b>		Pump, Victaulic screen filter, relief valve, water and air vent valve, pressure sensors											
<b>Pump</b>		Centrifugal pump, monocell, 48,3 r/s, low- or high-pressure (as required), single or dual (as required)											
Expansion tank volume (Option 293)	l	12	12	12	12	12	12	12	35	35	35	35	35
Buffer tank volume (Option 307)	l	208	208	208	208	208	208	208	208	208	208	208	208
Max. water-side operating pressure with hydronic module	kPa	400	400	400	400	400	400	400	400	400	400	400	400
<b>Water connections with or without hydronic module</b>		Victaulic® type											
Connections	inches	2	2	2	2	2	2	2	2	2	2	2	2
External diameter	mm	60,3	60,3	60,3	60,3	60,3	60,3	60,3	60,3	60,3	60,3	60,3	60,3
<b>Casing paint colour</b>		Colour code RAL 7035											

(3) Values are guidelines only. Refer to the unit name plate.

## PHYSICAL DATA, SIZES 040R TO 160R

30RQ			040R	045R	050R	060R	070R	080R	090R	100R	120R	140R	160R	
<b>Standard unit</b>														
Heating Full load performances*	HA1	Nominal capacity	kW	44,1	47,9	54,3	61,6	68,2	61,8	93,3	106,6	119,1	136,8	123,1
		COP	kW/kW	3,91	3,97	3,89	3,80	3,81	3,03	3,80	3,80	3,80	3,80	3,80
	HA2	Nominal capacity	kW	42,7	47,0	53,5	59,5	67,2	75,7	91,7	104,5	117,6	134,9	150,2
		COP	kW/kW	3,07	3,16	3,12	3,01	3,08	3,01	3,10	3,09	3,09	3,08	3,08
Seasonal energy efficiency**	HA1	SCOP <sub>30/35°C</sub>	kWh/kWh	3,82	3,85	3,81	3,58	3,67	3,65	3,61	3,56	3,79	3,76	3,78
		η <sub>s</sub> heat <sub>30/35°C</sub>	%	150	151	149	140	144	143	141	139	149	147	148
		P <sub>rated</sub>	kW	31,6	33,5	36,4	42,7	49,8	55,0	59,9	68,4	87,0	99,6	99,6
Cooling Full load performances*	CA1	Nominal capacity	kW	41,0	43,1	50,3	60,2	65,2	74,3	87,0	99,9	114,2	131,6	147,2
		EER	kW/kW	2,89	2,69	2,66	2,97	2,90	2,66	2,88	2,84	2,93	2,85	2,66
Seasonal energy efficiency**		SEER <sub>12/7 °C</sub> Comfort low temp.	kWh/kWh	4,19	4,23	4,18	4,34	4,25	4,03	4,48	4,86	4,88	4,20	4,09
		SEPR <sub>12/7 °C</sub> Process high temp.	kWh/kWh	6,08	5,93	5,69	6,13	5,87	5,39	5,82	5,82	5,89	5,48	5,24
<b>Unit with Heating Optimized option 119D</b>														
Heating Full load performances*	HA1	Nominal capacity	kW	44,4	48,2	54,6	62,2	68,9	62,3	94,4	107,8	120,5	137,4	123,3
		COP	kW/kW	4,02	4,09	3,99	3,93	3,92	3,15	3,94	3,87	3,88	3,90	3,13
	HA2	Nominal capacity	kW	43,1	47,4	53,9	60,2	67,9	76,3	92,9	105,8	119,0	135,6	151,1
		COP	kW/kW	3,18	3,29	3,23	3,15	3,20	3,17	3,25	3,18	3,18	3,20	3,15
Seasonal energy efficiency**	HA1	SCOP <sub>30/35°C</sub>	kWh/kWh	3,97	4,00	3,96	3,78	3,88	3,89	3,77	3,71	3,95	3,98	4,00
		η <sub>s</sub> heat <sub>30/35°C</sub>	%	156	157	155	148	152	153	148	145	155	156	157
		P <sub>rated</sub>	kW	31,7	33,6	36,4	42,9	50,0	55,1	60,3	68,8	87,5	99,8	99,8
Cooling Full load performances*	CA1	Nominal capacity	kW	38,9	41,1	48,1	57,5	62,7	71,8	83,4	96,0	109,6	127,1	142,7
		EER	kW/kW	2,75	2,57	2,56	2,85	2,80	2,59	2,77	2,74	2,83	2,76	2,58
Seasonal energy efficiency**		SEER <sub>12/7 °C</sub> Comfort low temp.	kWh/kWh	3,95	4,00	3,98	4,15	4,06	3,89	4,29	4,63	4,66	4,10	4,02
		SEPR <sub>12/7 °C</sub> Process high temp.	kWh/kWh	5,68	5,56	5,39	5,79	5,56	5,17	5,52	5,49	5,58	5,33	5,16
<b>Sound levels</b>														
<b>Unit + option 16</b>														
		Sound power <sup>(1)</sup>	dB(A)	82	83	84	89	89,5	89,5	92	92	92	92,5	92
		Sound pressure at 10 m <sup>(2)</sup>	dB(A)	50	52	53	58	58	58	60	61	60	61	60,0
<b>Standard unit</b>														
		Sound power <sup>(1)</sup>	dB(A)	82	83	84	89	89,5	89,5	92	92	92	92,5	92
		Sound pressure at 10 m <sup>(2)</sup>	dB(A)	50	52	53	58	58	58	60	61	60	61	60,0
<b>Unit + option 15LS<sup>(3)</sup></b>														
		Sound power <sup>(1)</sup>	dB(A)	78,5	79	80,5	80,5	80,5	80,5	83,5	83,5	83,5	83,5	83,5
		Sound pressure at 10 m <sup>(2)</sup>	dB(A)	47	48	49	49	49	49	52	52	52	52	52

\* In accordance with standard EN14511-3:2022.  
 \*\* In accordance with EN14825:2022, average climatic conditions.  
 HA1 Heating mode conditions: Water type heat exchanger water inlet/outlet temperature 30 °C/35 °C, outdoor air temperature tdb/twb = 7 °C db/6 °C wb, evaporator fouling factor 0 m<sup>2</sup>. k/W  
 HA2 Heating mode conditions: Water type heat exchanger water inlet/outlet temperature 40 °C/45 °C, outdoor air temperature tdb/twb = 7 °C db/6 °C wb, evaporator fouling factor 0 m<sup>2</sup>. k/W  
 CA1 Cooling mode conditions: evaporator water inlet/outlet temperature 12 °C/7 °C, outdoor air temperature 35 °C, evaporator fouling factor 0 m<sup>2</sup>. k/W  
**η<sub>s</sub> heat<sub>30/35°C</sub> & SCOP<sub>30/35°C</sub>** Values in bold comply with Ecodesign Regulation (EU) No. 813/2013 for Heating applications  
**SEER<sub>12/7 °C</sub> & SEPR<sub>12/7 °C</sub>** Applicable Ecodesign regulation (EU) No. 2016/2281  
 (1) In dB ref=10<sup>-12</sup> W, (A) weighting. Declared dual-number noise emission value in accordance with ISO 4871 with an uncertainty of +/-3 dB(A). Measured in accordance with ISO 9614-1 and certified by Eurovent.  
 (2) In dB ref 20 µPa, (A) weighting. Declared dual-number noise emission value in accordance with ISO 4871 with an uncertainty of +/-3 dB(A). For information, calculated from the sound power Lw(A).  
 (3) Options: 15LS = Very low noise level, 116W = Variable-speed high pressure dual-pump hydraulic module, 307 = Water buffer tank module



Eurovent certified values

## PHYSICAL DATA, SIZES 040R TO 160R

30RQ		040R	045R	050R	060R	070R	080R	090R	100R	120R	140R	160R
<b>Dimensions</b>												
<b>Standard unit</b>												
Length	mm	2109	2109	2109	2109	2109	2109	2275	2275	2275	2275	2275
Width	mm	1090	1090	1090	1090	1090	1090	2125	2125	2125	2125	2125
Height	mm	1330	1330	1330	1330	1330	1330	1330	1330	1330	1330	1330
Unit height (option 12)	mm	1372	1372	1372	1372	1372	1372	1372	1372	1372	1372	1372
Unit height (option 307)	mm	1931	1931	1931	1931	1931	1931	1931	1931	1931	1931	1931
Unit height (option 12 +307)	mm	1973	1973	1973	1973	1973	1973	1973	1973	1973	1973	1973
<b>Operating weight<sup>(4)</sup></b>												
Standard unit	kg	444	446	469	496	506	515	759	818	866	996	1000
Unit + single high-pressure pump option	kg	464	466	489	516	526	535	779	838	891	1021	1025
Unit + dual high-pressure pump option	kg	491	493	516	543	553	562	805	864	923	1054	1058
Unit + single high-pressure pump and buffer tank options	kg	800	802	825	852	862	871	1174	1233	1286	1416	1420
Unit + dual high-pressure pump and buffer tank options	kg	827	829	852	879	889	898	1200	1259	1318	1449	1453
<b>Compressors</b>												
Hermetic Scroll 48,3 r/s												
Circuit A		2	2	2	2	2	2	2	3	3	2	2
Circuit B											2	2
No. of power stages		2	2	2	2	2	2	2	3	3	4	4
<b>Refrigerant<sup>(4)</sup></b>												
R-32 / A2L/ PRP= 675 in accordance with AR4												
Circuit A	kg	7,30	7,30	7,80	8,70	8,95	9,20	15,20	15,70	19,60	8,95	9,15
	tCO <sub>2</sub> e	4,9	4,9	5,3	5,9	6,0	6,2	10,3	10,6	13,3	6,0	6,2
Circuit B	kg										8,95	9,15
	tCO <sub>2</sub> e										6,0	6,2
<b>Oil</b>												
Oil type												
Circuit A	l	6,0	6,0	6,6	6,6	7,2	7,2	7,2	10,8	10,8	7,2	7,2
Circuit B	l										7,2	7,2
<b>Capacity control</b>												
SmartVu™												
Minimum capacity	%	50	50	50	50	50	50	50	33	33	25	25
<b>PED category</b>												
III												
<b>Condenser</b>												
Grooved copper tubes and aluminium fins												
<b>Fans</b>												
Axial Flying bird™ 6 with rotating shroud												
<b>Standard unit</b>												
Quantity		1	1	1	1	1	1	2	2	2	2	2
Maximum total air flow	l/s	4034	4034	4034	5613	5613	5613	10904	10904	10904	11226	11226
Maximum rotation speed	r/s	12	12	12	16	16	16	16	16	16	16	16
<b>Evaporator</b>												
Dual-circuit plate heat exchanger												
Water volume	l	3,55	4	4,44	5,18	6,07	6,96	7,4	8,44	9,92	12,69	14,31
Max. water-side operating pressure without hydronic module	kPa	1000	1000	1000	1000	1000	1000	1000	1000	1000	1000	1000
<b>Hydronic module (option)</b>												
Pump, Victaulic screen filter, relief valve, water and air vent valve, pressure sensors												
Centrifugal pump, monocell, 48,3 r/s, low- or high-pressure (as required), single or dual (as required)												
Pump												
Expansion tank volume (Option 293)	l	12	12	12	12	12	12	35	35	35	35	35
Buffer tank volume (Option 307)	l	208	208	208	208	208	208	208	208	208	208	208
Max. water-side operating pressure with hydronic module	kPa	400	400	400	400	400	400	400	400	400	400	400
<b>Water connections with or without hydronic module</b>												
Victaulic® type												
Connections	inches	2	2	2	2	2	2	2	2	2	2	2
External diameter	mm	60,3	60,3	60,3	60,3	60,3	60,3	60,3	60,3	60,3	60,3	60,3
<b>Casing paint colour</b>												
Colour code RAL 7035 & 7024												

(3) Options: 15LS = Very low noise level, 116W = Variable-speed high pressure dual-pump hydraulic module, 307 = Water buffer tank module,

(4) Values are guidelines only. Refer to the unit name plate.

## ELECTRICAL SPECIFICATIONS

30RB/30RQ		040R	045R	050R	055R	060R	070R	080R	090R	100R	120R	140R	160R
<b>Power circuit supply</b>													
Nominal voltage	V-ph-Hz	400 - 3 - 50											
Voltage range	V	360 - 440											
<b>Control circuit supply</b>													
24 V via internal transformer													
<b>Maximum operating input power<sup>(1) or (2)</sup></b>													
Circuit A&B	kW	19	21	24	24	28	31	36	41	48	55	63	71
<b>Power factor at maximum power<sup>(1) or (2)</sup></b>													
Displacement Power Factor (Cos Phi), standard unit		0,81	0,82	0,82	0,82	0,84	0,84	0,85	0,82	0,84	0,85	0,84	0,85
<b>Nominal unit current draw<sup>(4)</sup></b>													
Standard unit	A	26	29	35	35	36	46	52	59	71	81	91	104
<b>Maximum operating current draw (Un)<sup>(1) or (2)</sup></b>													
Standard unit	A	34	37	42	42	48	54	60	72	84	93	108	121
<b>Maximum current (Un-10%)<sup>(1) or (2)</sup></b>													
Standard unit	A	37	39	44	44	51	58	65	77	89	99	115	129
<b>Maximum start-up current (Un)<sup>(2) + (3)</sup></b>													
Standard unit	A	116	118	165	165	169	177	191	238	206	223	231	251

(1) Values at the unit's permanent maximum operating condition (as shown on the unit's nameplate).

(2) Values at the unit's maximum operating condition (as shown on the unit's nameplate).

(3) Maximum operating current of the smallest compressor(s) + fan current + locked rotor current of the largest compressor.

(4) Standardised EUROVENT conditions, water-cooled exchanger inlet/outlet = 12 °C/7 °C, outdoor air temperature = 35 °C.

### Short-circuit withstand current (TN system)<sup>(1)</sup>

30RB/30RQ		040R	045R	050R	055R	060R	070R	080R	090R	100R	120R	140R	160R
<b>Rated short-circuit withstand currents</b>													
Rated short time (1s) current - I <sub>cw</sub>	kA eff	3,36	3,36	3,36	3,36	3,36	3,36	5,62	5,62	5,62	5,62	5,62	5,62
Rated peak current - I <sub>pk</sub>	kA pk	20	20	20	20	20	20	15	20	20	15	20	15
<b>Value with upstream electrical protection <sup>(1)</sup></b>													
Rated conditional short circuit current I <sub>cc</sub>	kA eff	40	40	40	40	40	40	40	40	40	40	30	30
Associated protection - type/supplier		Circuit breaker/Schneider											
Associated protection - rating/reference		NS100H	NS100H	NS100H	NS100H	NS100H	NS100H	NS100H	NS100H	NS100H	NS160H	NS160H	NS250H

(1) If another current limitation protection device is used, its time-current and thermal constraint (I<sup>2</sup>t) trip characteristics must be at least equivalent to those of the recommended protection.

**Note: The short circuit current withstand capability values above have been established for the TN system.**



## DIMENSIONS/CLEARANCES

### 30RB/30RQ 040R-080R, units without water buffer tank module

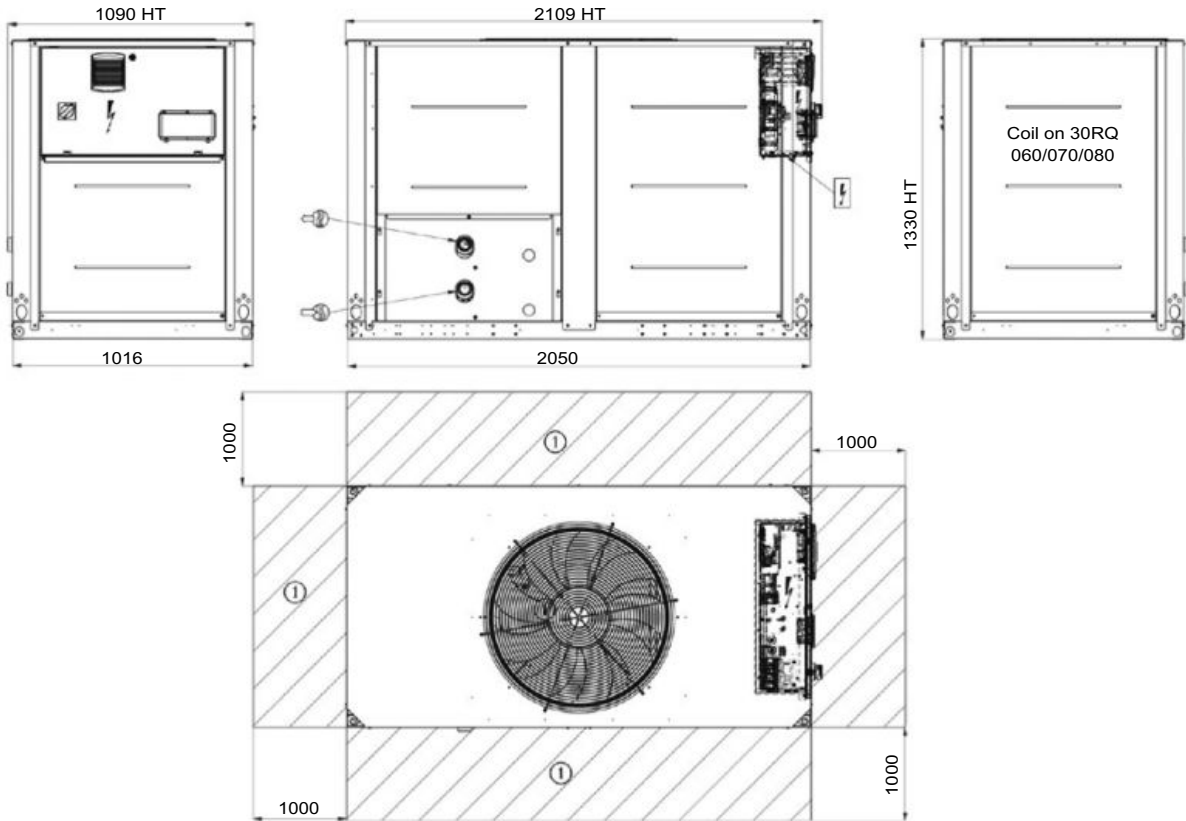

**Key:**

All dimensions are given in mm.

- ① Clearances required for maintenance and air flow
- ② Clearance recommended for coil removal
- Water inlet
- Water outlet
- Air outlet, do not obstruct
- Control box

**NOTE: Non-contractual drawings.**

When designing a system, refer to the certified dimensional drawings provided with the unit or available on request.

Refer to the certified dimensional drawings for:

- The location of the fixing points,
- The weight distribution,
- The coordinates of the centre of gravity, hydraulic and electrical connections,
- Details of the 12/12A/23B option connections.

## DIMENSIONS/CLEARANCES

### 30RB/30RQ 090R-160R, units without water buffer tank module

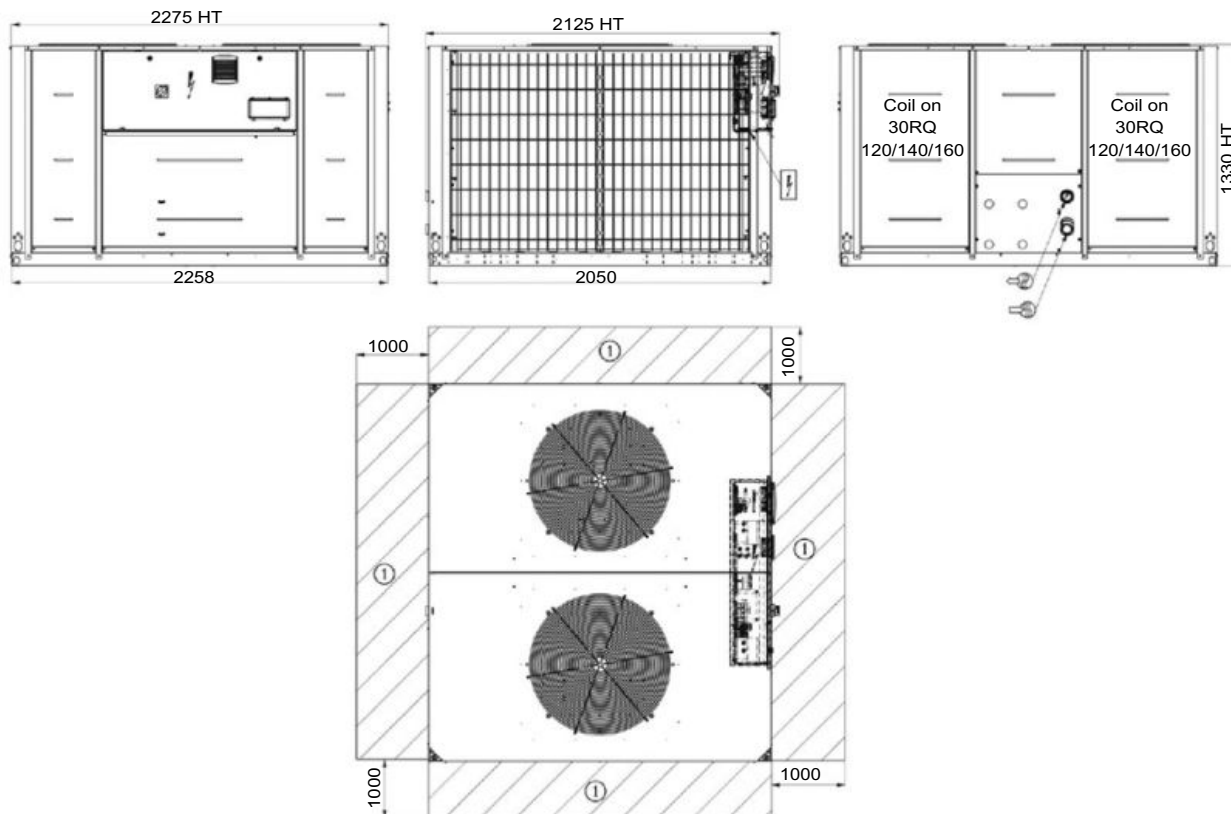
**Key:**

All dimensions are given in mm.

- ① Clearances required for maintenance and air flow
- ② Clearance recommended for coil removal
- Water inlet
- Water outlet
- Air outlet, do not obstruct
- Control box

**NOTE: Non-contractual drawings.**

When designing a system, refer to the certified dimensional drawings provided with the unit or available on request.

Refer to the certified dimensional drawings for:

- The location of the fixing points,
- The weight distribution,
- The coordinates of the centre of gravity, hydraulic and electrical connections,
- Details of the 12/12A/23B option connections.

## DIMENSIONS/CLEARANCES

### 30RB/30RQ 040R-080R, units with water buffer tank module

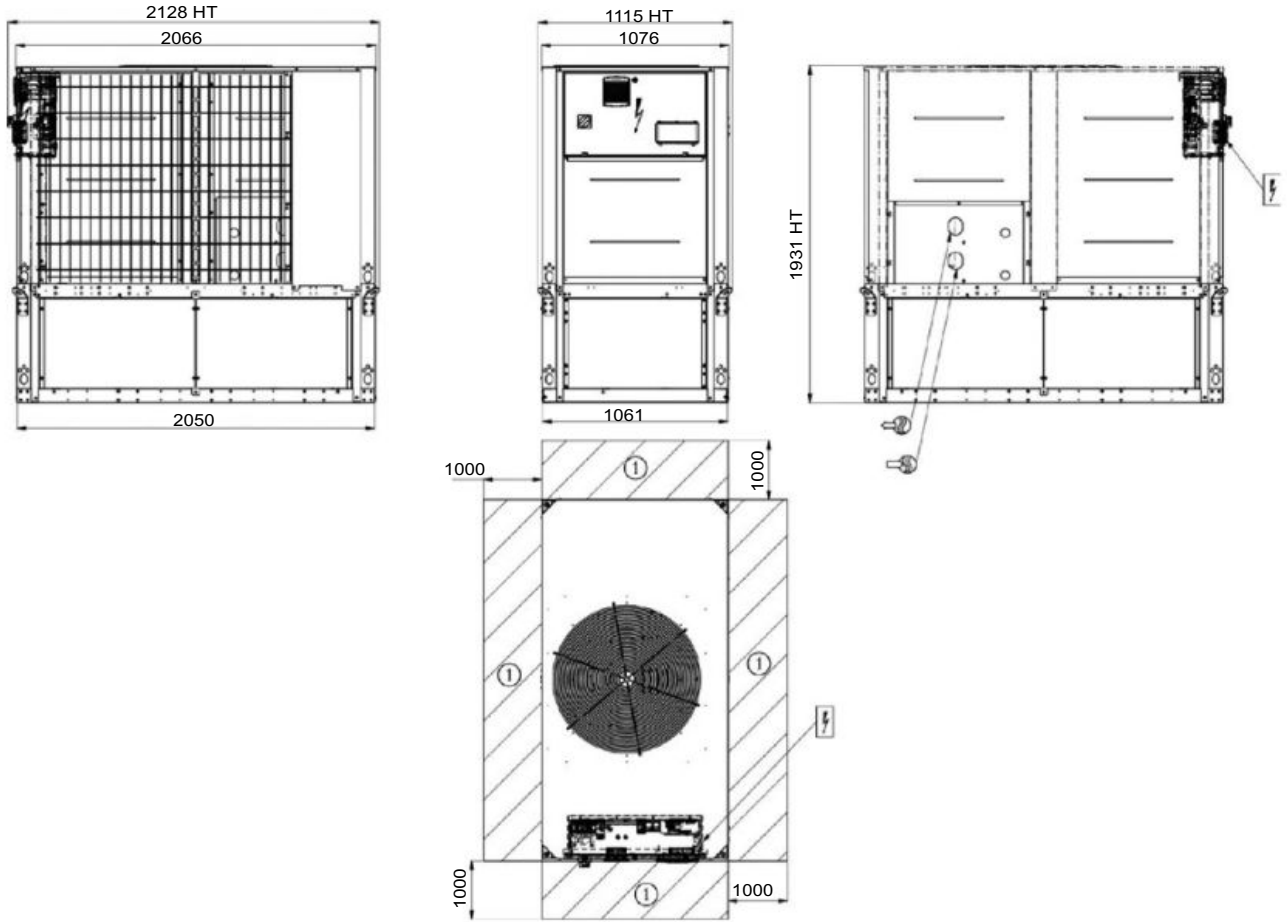

**Key:**

All dimensions are given in mm.

- ① Clearances required for maintenance and air flow
- ② Clearance recommended for coil removal
- ⊕ Water inlet
- ⊖ Water outlet
- ⋈ Air outlet, do not obstruct
- ⚡ Control box

**NOTE: Non-contractual drawings.**

When designing a system, refer to the certified dimensional drawings provided with the unit or available on request.

Refer to the certified dimensional drawings for:

- The location of the fixing points,
- The weight distribution,
- The coordinates of the centre of gravity, hydraulic and electrical connections,
- Details of the 12/12A/23B option connections.

## DIMENSIONS/CLEARANCES

### 30RB/30RQ 090R-160R, units with water buffer tank module

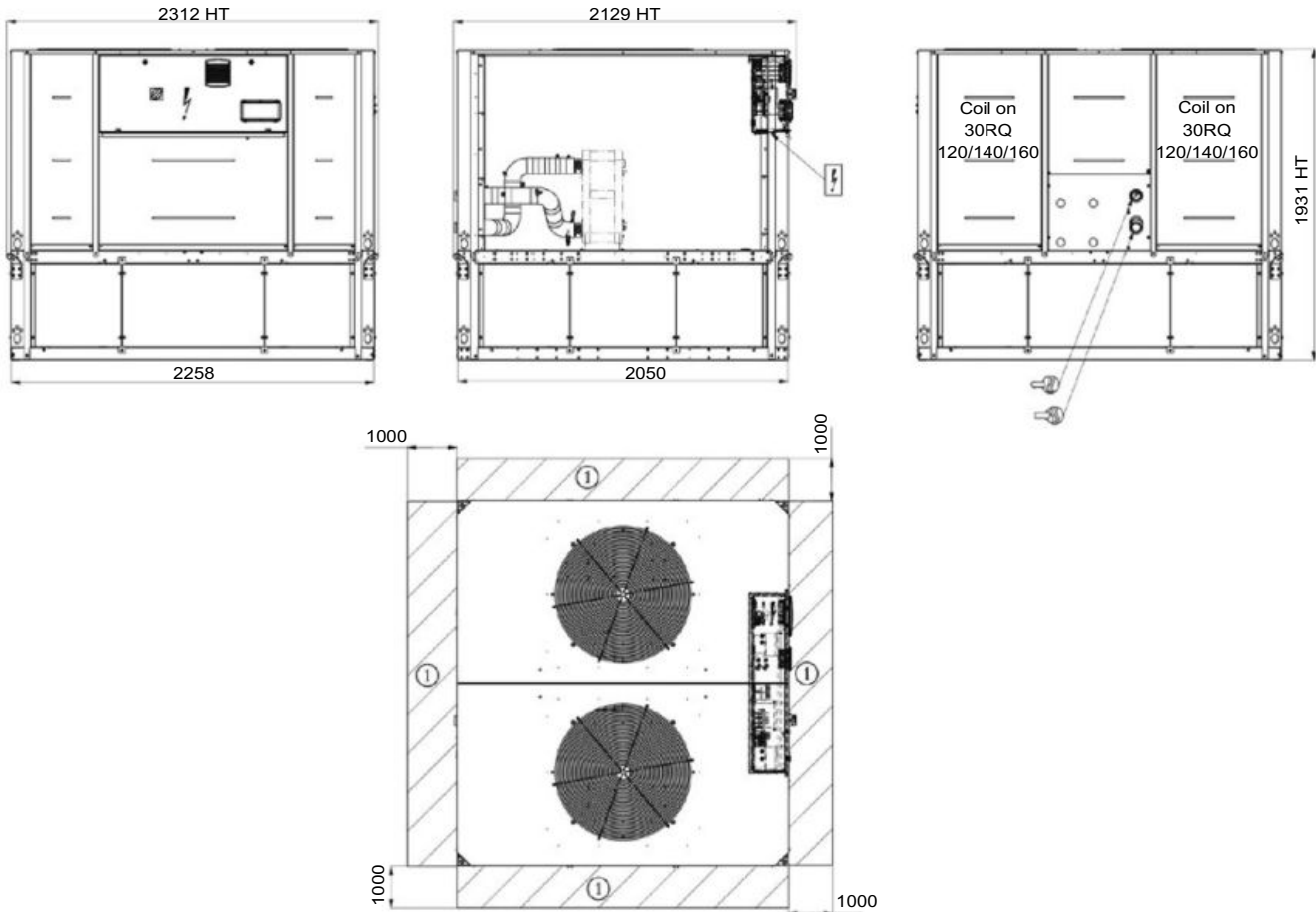

**Key:**

All dimensions are given in mm.

- ① Clearances required for maintenance and air flow
- ② Clearance recommended for coil removal
- Water inlet
- Water outlet
- Air outlet, do not obstruct
- Control box

**NOTE: Non-contractual drawings.**

When designing a system, refer to the certified dimensional drawings provided with the unit or available on request.

Refer to the certified dimensional drawings for:

- The location of the fixing points,
- The weight distribution,
- The coordinates of the centre of gravity, hydraulic and electrical connections,
- Details of the 12/12A/23B option connections.





# SCROLL CHILLERS WITH AIR COOLED CONDENSER AND GREENSPEED® INTELLIGENCE



Unit with low noise level option

Low environmental impact

High full and part load efficiency

Compact and simple to install

Low refrigerant charge

Superior reliability

## 30RB/30RBP 170R-950R

Nominal cooling capacity 170-940 kW



Aquasnap® heat pumps and liquid chillers are the best solution for commercial and industrial applications where installers, engineering and design departments and building owners require reduced installation costs, optimal performances and maximum quality.

The latest generation AquaSnap® is available in two new versions:

- The AquaSnap® (30RB-30RQ) version is a compact all-in-one package optimised for full-load applications where reduced investment cost (low CapEx) is required.
- The premium AquaSnap® version with Greenspeed® intelligence (30RBP-30RQP) is optimised for part load applications where a high SEER, SEPR, SCOP or IPLV value is required. This version is equipped with a variable-speed pump and fans, providing premium part load efficiency to reduce maintenance costs over the lifespan of the chiller. In addition, the sound levels achieved under the part load conditions are particularly low. Besides operating efficiently and quietly, the AquaSnap® range with Greenspeed® intelligence operates from -20 °C up to +48 °C as standard.



\* The availability of sizes and options depends on the country. Please contact your local commercial dealer for more information.

CARRIER participates in the ECP programme for LCP-HP  
Check ongoing validity of certificate:  
[www.eurovent-certification.com](http://www.eurovent-certification.com)

## R-32: THE BEST SOLUTION FOR SCROLL LIQUID CHILLERS AND HEAT PUMPS



Carrier was the first to introduce the R-1234ze HFO with ultra-low GWP in screw chillers, as far back as early 2016. Today, having examined its main properties, Carrier has chosen R-32 refrigerant to replace high-GWP R-410A refrigerant in its Scroll liquid chillers and heat pumps, for its lower environmental impact, high energy efficiency, good availability and ease of use.

R-32 is currently the ideal refrigeration solution for units equipped with Scroll compressors. By using R-32 refrigerants, Carrier has reduced the carbon footprint of its AquaSnap® range of liquid chillers and heat pumps by 77%. This is the result of a much lower GWP and a significant reduction in the system's cooling load compared to the previous generation that used R-410A.

R-32 is also the right choice economically, reducing the locally imposed tax burden on HFCs based on the CO<sub>2</sub> impact.



**CO<sub>2</sub> FOOTPRINT**  
REDUCED BY UP TO **-77%**

### Lower environmental impact (-77% compared to R410A)

- R-32 has zero ozone depletion potential (ODP)
- The Global Warming Potential (GWP) of R-32 is 675, i.e. approximately one third of that of R-410A (PRP 2088)
- The AquaSnap® R-32 cooling load is reduced by 30% compared to the previous version using R-410A<sup>(1)</sup>
- The carbon footprint of AquaSnap® R-32 is therefore 473 (675 x 0.7), i.e. 77% lower than the version using R-410A (2088 x 1)

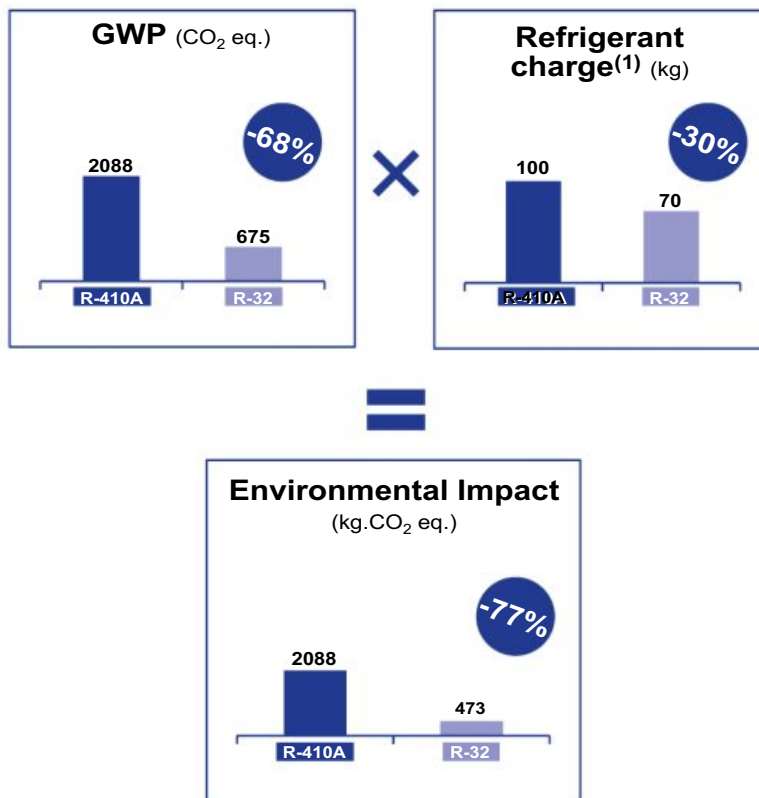

(1) Reduced refrigerant charge in Carrier heat pumps thanks to the use of R-32 and a new coil design.

## R-32: THE BEST SOLUTION FOR SCROLL LIQUID CHILLERS AND HEAT PUMPS



**SEER** up to **+10%**  
**SCOP** up to **+6%**

### High energy efficiency

The seasonal efficiency of AquaSnap® R-32 is higher than that of the previous R-410A version by:

- Approximately +10% in cooling mode
- Approximately +6% in heating mode

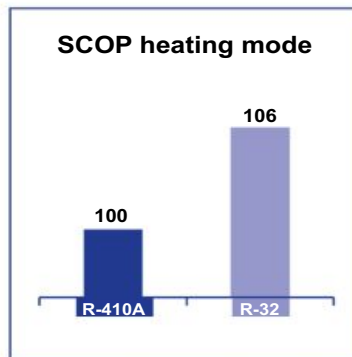
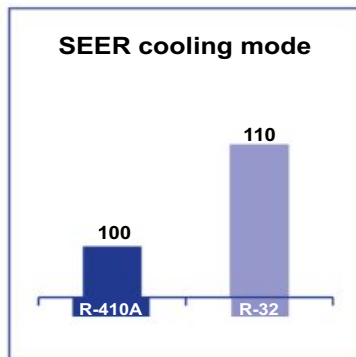

### SIMPLICITY

### Widely available and easy to use

More than 50 million R-32 air conditioning units are in circulation on the global market. While R-32 has been used for some time in residential and commercial air conditioning units, most manufacturers now use R-32 in VRF systems, liquid chillers and heat pumps, which means R-32 is widely available around the world.

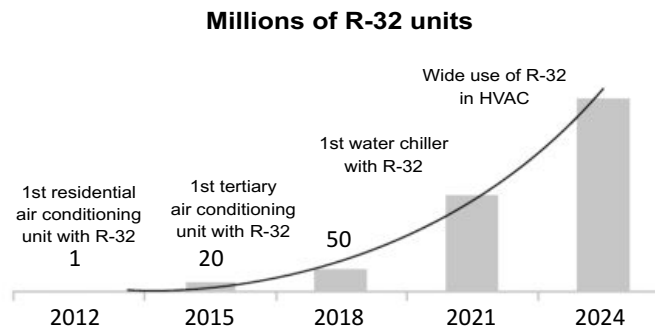

R-32 has been widely available for over 15 years, as it comprises 50% of the composition of R-410A.

R-32 is easy to use: It is a pure refrigerant, therefore it is not necessary to drain the entire circuit in the event of a leak.



### SAFETY

R-32 is an A2L classified refrigerant thanks to its low flammability.

- **No specific safety requirements** for transporting chillers by road.
- **Easy outdoor installation** in line with the requirements of standard EN 378.
- The service tools must be **certified for A2L** refrigerants in accordance with standard ISO 817 or EN378.
- Service technicians **must be qualified for brazing components** on PED 2 fluid units.



## AQUASNAP® - CUSTOMER BENEFITS

### Outstanding performance

Equipped with variable-speed fans (VSD as standard and EC optional) and optional variable-speed pumps, Carrier's AquaSnap® 30RBP/RQP range with Greenspeed® intelligence automatically adjusts the cooling capacity and water flow to perfectly adapt to the building's requirements or load variations. The result is optimum operation at both full load and part load (SEER up to 5.4, SCOP of 3.9). The 30RBP/RQP offers energy efficiency up to 10% higher than the previous range with the same or a smaller footprint.

The range is already fully compliant with the 2021 Ecodesign regulations.

### Intelligence and connectivity

The advanced SmartVu™ intelligent control system displays operating parameters in real time, making it intuitive and particularly user-friendly. The AquaSnap® 30RBP/RQP range is also characterised by a brand new smart energy monitoring function which provides users with smart data such as electrical energy consumption in real time, supplied cooling and heating energy and instantaneous and average seasonal energy efficiency values. For even greater energy savings, the AquaSnap® 30RBP/RQP can be monitored remotely by Carrier experts to further optimise the energy consumption level.



SEER up to **5.4**  
SCOP up to **3.9**



SMART ENERGY  
MONITORING

### Extensive field of application

The AquaSnap® range is suitable for a very wide range of applications from tertiary to industrial processes. The range can operate at outdoor temperatures from -20 °C to +48 °C and with negative water temperatures (-8 °C). From high-end office buildings and hotels to healthcare facilities, data centers and industrial projects, AquaSnap® 30RBP/RQP units meet the most demanding expectations in terms of energy efficiency and savings, whatever the climate or application.

### Easy installation & maintenance

Thanks to the variable-speed pumps up to 950 kW, automatic adjustment of the nominal water flow rate via electronic control and automatic measurement of the unit's energy performance under real conditions, the pumping energy consumption is reduced by almost two thirds: these new features guarantee peace of mind for installers and maintenance companies and lower energy bills for users.



BETWEEN  
**-20 °C**  
and **48 °C**



Pumping energy  
reduced by  
up to **66%**

## AQUASNAP® - CUSTOMER BENEFITS

AquaSnap® liquid chillers and heat pumps are designed to meet current and future Ecodesign and F-Gas European regulation requirements in terms of energy efficiency and reduced CO<sub>2</sub> emissions. They use the best technologies available today:

- Reduced refrigerant charge of non-ozone depleting R-32A refrigerant with low GWP
- Scroll compressors
- Greenspeed® variable-speed fans (30RBP-30RQP models)
- NOVATION™ micro-channel heat exchangers with a new aluminium alloy (30RB/RBP)
- Brazed-plate heat exchangers with reduced pressure drops
- Self-regulating microprocessor control with Greenspeed® intelligence
- Colour touch screen with web connectivity options

Both AquaSnap® versions can be equipped with a built-in hydraulic module, limiting the installation to conventional operations such as connection of the power supply and the supply and return piping (plug & play), according to the dimensions of the standard unit.

Recommended by Carrier, the AquaSnap® can be equipped with one or two Greenspeed® variable-speed pumps to significantly reduce energy costs linked to pumping (reduction of more than two-thirds), ensure optimum water flow rate control, and improve overall system reliability.



### Very economical operation

- High unit full- and part-load energy efficiency and efficient design of the water side:
  - SEER<sub>12/7°C</sub> up to 5.4 (30RBP version) in accordance with the new Ecodesign 2016/2281 regulations and SCOP 35 °C up to 3.9 (30RQP version).
  - Multiple scroll compressors equipped with a high-efficiency motor which can exactly match the cooling capacity to the load required
  - Electronic expansion valve enabling operation at a lower condensing pressure and improved use of the evaporator heat transfer area (superheat control)
  - Condenser with high-efficiency NOVATION™ (30RB/RBP) aluminium micro-channel heat exchangers and Greenspeed® variable-speed fans (30RBP-30RQP version)
  - Low pressure drop brazed plate heat exchangers (< 45 kPa under Eurovent conditions).

- Specific control functions to reduce unit cooling energy use during occupied and unoccupied periods:
  - Internal timer: Switches the chiller on/off and controls operation at a second setpoint
  - Setpoint automatically offset based on the outdoor air temperature or room air temperature (via an option)
  - Floating high pressure (HP) management
  - Variable-speed fan control
  - Cooling demand limitation.

Refer to the control chapter for more information.

- Greenspeed® variable-speed pump to reduce pumping energy consumption by up to two-thirds (option recommended by Carrier):
  - Eliminate energy losses through the water flow rate control valve by electronically setting the nominal water flow rate
  - Save energy during stand-by periods or part-load operation by automatically reducing the water pump speed. The energy consumption of the pump motor varies according to the cube of the speed, so that a reduction in speed of just 40% can reduce energy consumption by 80%
  - Improved unit part-load performance (increased SEER/SCOP value with variable water flow according to standard EN14825).

Refer to the hydraulic option chapter for more information.



- Extra energy savings through multiple options:
  - Carrier dry cooler free cooling mode management
  - Partial or total heat recovery.
- Reduced maintenance costs:
  - Fast diagnosis of possible incidents and their history via the control
  - Programmable maintenance alert
  - Programmable F-Gas leak monitoring alert

## AQUASNAP® - CUSTOMER BENEFITS

### Low noise level

- Condenser with fixed-speed fans (30RB-30RQ):
  - Optional low-speed fans (700 rpm) and compressor enclosure to reduce full-load noise level by 6 to 7 dB(A)
  - Condenser coils in V-shape with an open angle, allowing quieter air flow across the coil
  - Low noise 6th generation Flying Bird™ fans, made of a composite material (Carrier patent)
  - Rigid fan installation for reduced noise (Carrier patent).
- Condenser with Greenspeed® variable-speed fans (30RBP-30RQP) recommended by Carrier for even quieter operation):
  - Optional factory setting of the fan at low speed, with compressor enclosure to reduce full-load noise level by 6 to 7 dB(A)
  - Exceptional acoustic signature during part-load operation through smooth fan speed variation.
- Specific control functions or features to reduce noise level during the night or unoccupied periods:
  - Night-time sound control with cooling capacity and fan speed limitation
  - Low-noise scroll compressors with low vibration level
  - The compressor assembly is installed on an independent chassis and supported by flexible anti-vibration mountings
  - Dynamic suction and discharge piping support, minimising vibration transmission (Carrier patent)
  - Acoustic compressor enclosure, reducing radiated noise emissions (optional).



### Quick and easy installation

- Compact design:
  - AquaSnap® units are designed with compact dimensions for easy installation.
  - With a length of approximately 4.8 m for 550 kW and a width of 2.25 m, the units require minimal floor space.
- Built-in hydraulic module (option):
  - Low or high pressure water pump (as required)
  - Single or dual pump (as required) with operation time balancing and automatic changeover to the back-up pump if a fault develops
  - Built-in variable-speed pumps with automatic nominal water flow adjustment via electronic control on the user display.
  - Water filter protects the water pump against circulating debris
  - Pressure sensors for direct numerical display of the water flow rate and water pressures
  - Thermal insulation and frost protection down to -20 °C, using a heater (optional)
  - High-capacity membrane expansion tank (option).

- Built-in hydraulic module with Greenspeed® variable-speed pump (option recommended by Carrier):
  - Quick and easy electronic setting of the nominal water flow rate when the unit is commissioned, thus eliminating the need to adjust the water flow rate control valve
  - Automatic control of the pump speed based on constant speed, constant pressure difference or constant temperature difference.
- Simplified electrical connections
  - A single power connection point without neutral
  - Main disconnect switch with high trip capacity
  - 24 V control circuit using a built-in transformer.
- Simplified hydraulic connections:
  - Victaulic type couplings on the exchanger;
  - Clearly identified and practical reference marks for water outlet and inlet connections;
- Fast unit commissioning
  - Systematic factory test before shipment
  - Quick-test function for step-by-step verification of the sensors, electrical components and motors.

### Reduced installation costs

- Optional Greenspeed® variable-speed pump with hydraulic module (option recommended by Carrier)
  - Cut costs relating to the water flow control valve
  - The design of the water system with variable primary flow (VPF) can provide significant installation cost savings compared with traditional constant primary systems with variable secondary circuits; elimination of the secondary distribution pump, etc.
  - Water system design with fan coil units fitted with 2-way valves instead of 3-way valves.
- No buffer tank required thanks to Carrier's advanced control algorithm
  - Minimum water loop volume reduced to 2.5 l/kW.

### Environmentally responsible

- AquaSnap® liquid chillers with Greenspeed® intelligence are a boost for green cities and contribute to a sustainable future. Combining a refrigerant charge up to 30% lower, with R-32 refrigerant with a GWP 70% lower than that of the previous version using R410A, and exceptional energy efficiency, this chiller significantly reduces energy consumption while reducing carbon dioxide emissions throughout its life cycle.
- The AquaSnap® liquid chiller is equipped with an automatic energy meter that indicates the instantaneous and overall cooling energy at the outlet, the instantaneous and overall electrical energy consumption, the instantaneous and average seasonal energy efficiency for monitoring and a unit performance check.
  - Pumping energy consumption can be reduced by up to 2/3 using Greenspeed® variable-speed pumps

## AQUASNAP® - CUSTOMER BENEFITS

- Lower refrigerant charge: the micro-channel technology used for condenser coils optimises heat transfer while minimising the refrigerant volume.
- Sealed refrigerant circuits:
  - Leaks are eliminated thanks to the absence of capillary tubes and the use of flare connections
  - Verification of pressure transducers and temperature sensors without transferring the refrigerant charge
  - Discharge line shut-off valve and liquid duct service valve for simplified maintenance
  - Qualified Carrier maintenance personnel to provide refrigerant servicing
  - ISO 14001 production plant
- Refrigerant leak detection: available as an option, this additional dry contact allows reporting of possible leaks. The leak detector (supplied externally) should be mounted in the most likely leak location.
- Self-regulating control
  - The control algorithm prevents excessive compressor cycling and reduces the quantity of water in the water loop (Carrier patent)
  - Automatic compressor unloading in case of abnormally high condensing pressure
  - Automatic fan speed adjustment in case of coil fouling (30RBP-30RQP models)
  - Soft fan start to increase unit lifetime (30RBP-30RQP models).
- Exceptional endurance tests:
  - To design critical components and sub-assemblies to minimise the risk of failure on site, Carrier uses specialised laboratories and advanced dynamic simulation tools.
  - To ensure that the units reach customer sites in the same condition as they are when tested in the factory, Carrier tests the machine behaviour during transportation over 250 km. The road test is based on a military standard and is the equivalent to 5000 km by truck on a normal road.
  - To guarantee the coil corrosion resistance, salt spray corrosion resistance tests are performed in the group's laboratory.
  - In addition, to maintain the unit's performance throughout its operating life whilst minimising maintenance costs, end users can access the "Connected Services" remote monitoring service.

### Superior reliability

- State-of-the-art concept
  - Two self-contained refrigerant circuits; the second one automatically takes over if the first one develops a fault, maintaining partial cooling in all circumstances
  - All compressor components are easily accessible on site, minimising downtime
  - All-aluminium Novation™ micro-channel heat exchanger (MCHE) (30RB-30RBP) with higher corrosion resistance than a conventional coil. The all-aluminium construction eliminates the formation of galvanic currents between aluminium and copper which can corrode the coil in saline or corrosive atmospheres
  - V-coil design to protect the coils against hail impact
  - Optional Enviro-shield® anti-corrosion coil coating for use in moderately corrosive environments. Coating applied through conversion process which modifies the surface of the aluminium producing a coating that is integral to the coil. Immersion in a bath to ensure 100% coverage. No heat transfer variation, tested for 4000 hours in salt spray per ASTM B117
  - Optional Super Enviro-shield® anti-corrosion coil coating for use in extremely corrosive environments. Extremely durable and flexible epoxy polymer coating applied on the outer surface of the coil using an electro coating process with a final UV protective topcoat. Minimal heat transfer variation, tested for 6000 hours in salt spray per ASTM B117, superior impact resistance per ASTM D2794
  - Electronic flow switch. Auto-setting according to cooler size and fluid type.

### Designed to support Green Building Design

A green building is a building that is environmentally sustainable and is designed, constructed and operated to minimise the total impact on the environment.

The resulting building will be economical to operate, offer increased comfort and create a healthier environment for the people who live and work there, increasing productivity.

The air conditioning system can use between 30 and 40% of the annual building energy consumption. Choosing the right air conditioning system is one of the main considerations when designing a green building. For buildings with a load that varies throughout the year, the AquaSnap® 30RBP/RQP unit offers a solution to this important challenge.

A number of green building certification programmes exist in the market and offer third-party assessment of green building measures for a wide variety of building types.

The following example looks at how Carrier's new AquaSnap® range helps customers affected by the LEED® building certification.



## AQUASNAP® - CUSTOMER BENEFITS

### Energy saving certificate

The AquaSnap® 30RBP/RQP unit is eligible for energy saving certificates in France (CEE) in comfort, industrial and agriculture applications:

- Floating High pressure control (by modulating the air flow through fan activation and speed)
- Floating Low pressure control
- Variable speed on asynchronous fan motor
- Variable speed on asynchronous pump motor
- Partial or total recovery of energy

For more details about financial incentives in France, please refer to the "CEE product sheet".

### AquaSnap® and LEED® certification

The LEED® (Leadership in Energy and Environmental Design) green building certification programme is a major initiative set up to assess the design, construction and operation of green buildings with points assigned in seven credit categories:

- Sustainable Sites (SS),
- Water efficiency (WE),
- Energy and atmosphere (EA),
- Materials and resources (MR)
- Indoor environmental quality (IEQ)
- Innovation in design (ID)
- Regional Priority (RP).

There are a number of different LEED® products.

While the strategies and categories assessed remain the same, the distribution of points varies depending on the type of building and the requirements of the application, based on whether it is a new construction, school, core & shell, retail or healthcare.

All programmes now use the same point scale:

#### 110 LEED® points available

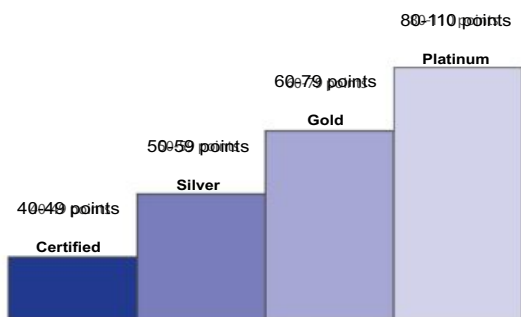

The majority of credits in LEED® rating systems are performance-based and achieving them is dependent on the impact of each component or sub-system on the building as a whole.

While the LEED® green building certification programmes do not certify products or services, choosing the right products, systems or service programmes is critical to obtaining LEED® certification for a registered project, because the right products or service programmes can help meet the goals of green construction and ongoing operation and maintenance.

The choice of heating, ventilation and air conditioning (HVAC) products in particular can have a significant impact on LEED® certification, as the HVAC system directly impacts two categories that together influence 40% of the available points.

### EcoPassport®

The PEP ecopassport® programme provides an international reference framework for procedures enabling manufacturers to report the environmental specifications of their products in the form of an environmental claim known as a Product Environmental Profile (PEP).

The PEP ecopassport® programme guarantees that PEPs are correctly drawn up, verified and reported in line with the requirements of the ISO 14025 and IEC/PAS 62545 standards.

The Life Cycle Analysis (LCA) PEP is the environmental identity card for an item of equipment which details the environmental impacts of the product during its life cycle according to eight mandatory indicators:

1. Global Warming Potential
2. Impact on the ozone layer
3. Acidification of soil and water
4. Eutrophication of water
5. Photochemical ozone creation
6. Abiotic resource depletion
7. Fresh water consumption
8. Total use of primary energy during the life cycle

Products with certified environmental profiles are used to support methods to assess building sustainability such as BREEAM, LEED. BREEAM, LEED gives additional recognition for materials with robust environmental product declaration types using manufacturer data.

Carrier is the first HVAC manufacturer to provide PEPs for liquid chillers and heat pumps with not only the 8 mandatory indicators, but all 27 indicators.

The PEP for the AquaSnap® 30RBP can be downloaded from the PEP ecopassport® website: <http://www.pep-ecopassport.org/fr/>

## AQUASNAP® - CUSTOMER BENEFITS

### Designed to support Green Building Design

#### Overview of LEED® for new construction and major renovations

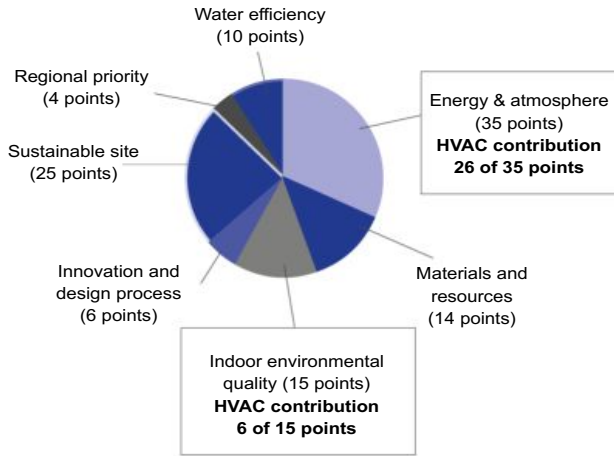

The new AquaSnap® units from Carrier can help building owners to earn LEED® points in particular in the Energy & Atmosphere (EA) credit category and help address the following prerequisites and credit requirements:

- EA prerequisite 2: minimum energy performance
- 30RBP/RQP units exceed the energy efficiency requirements of ASHRAE 90.1-2007; therefore they satisfy the prerequisites.
- EA prerequisite 3: fundamental refrigerant management  
30RBP/RQP units do not use chlorofluorocarbon (CFC) refrigerants, thus satisfying the prerequisites.
- EA credit 1: Optimise energy performance (1 to 19 points)  
Points for this credit are assigned depending on the energy cost reduction virtually achievable by the new building, compared to ASHRAE 90.1-2007 reference. 30RBP/RQP units, which are designed for high performance especially during part load operation, help to reduce the building's energy consumption and therefore to gain points for this credit. In addition, the Carrier HAP (Hourly Analyses Program) can be used to analyse energy. It meets the modelling requirements for this credit and produces reports which can be easily transferred to LEED® charts.
- EA credit 4: Enhanced refrigerant management (2 points)  
With this credit, LEED® awards systems that minimise the installed system's Ozone Depletion Potential (ODP) and Global Warming Potential (GWP). 30RBP/RQP units use a reduced R-32 charge and therefore help satisfy the requirements of this LEED® credit.

**NOTE:** This section describes the prerequisites and credit requirements in LEED® for new construction and is directly related to 30RBP/RQP units. Other prerequisites and credit requirements are not directly and purely related to the air conditioning unit itself, but more to the control of the HVAC system as a whole.

I-Vu®, Carrier's open control system, has features that can be valuable for:

- EA prerequisite 1: fundamental commissioning of energy management systems;
- EA credit 3: enhanced commissioning (2 points);
- EA credit 5: measurements and verification (3 points).

**NOTE:** Products are not reviewed or certified under LEED®. LEED® credit requirements cover the performance of materials in aggregate, not the performance of individual products or brands. For more information on LEED®, visit [www.usgbc.org](http://www.usgbc.org).

## 30RB - 30RQ TECHNICAL OVERVIEW

PRESENTATION

COOLING

HEATING

AIR TREATMENT

CONTROLS



### COPPER/ALUMINIUM COILS (30RQ)

- Protective heat shrink sleeves around the distribution sections
- Coil heaters to prevent frost formation and help drain condensate during defrosting

### NOVATION™ SECOND GENERATION MICRO CHANNEL HEAT EXCHANGERS (30RB)

- Increased reliability with new aluminium alloy
- Significantly reduces the refrigerant charge (-40% compared to Cu/Al coils)
- Improved thermal performance, improved efficiency and lower pressure drops compared to Cu/Al coils
- Enviro-Shield® coating for mildly corrosive environments
- Super Enviro-Shield® coating for highly corrosive environments (industrial or marine applications)
- Easy cleaning with high pressure air or water washer



### SIXTH GENERATION FLYING BIRD™ FIXED-SPEED FANS

- Exclusive Carrier design
- Fan blade design inspired by nature
- High efficiency version with AC motor technology

### SCROLL COMPRESSORS



### REDUCED REFRIGERANT CHARGE



### SMARTVU™ CONTROL

- 9 languages available
- 4.3" user-friendly touch screen
- All main parameters displayed on one screen
- Direct access to the unit's technical drawings and the main service documents
- Very easy online monitoring
- Easy and secure access to unit parameters
- Optional BACnet, J-Bus or LON communication interfaces

### SMART ENERGY CONSUMPTION MONITORING

- Real time energy consumption estimation (kWh)
- Estimation of the supplied cooling/heating energy (kWh)
- Instantaneous and average energy efficiency values under real operating conditions
- Remote monitoring with "Connected service"

### HIGH-EFFICIENCY BRAZED PLATE HEAT EXCHANGER

- Latest generation asymmetrical type
- Low pressure drop



## 30RBP - 30RQP TECHNICAL OVERVIEW



### VARIABLE-SPEED PUMP

- Water flow electronic control and reading
- Automatic protection of the pump against low pressure
- Multiple control options:
  - Constant flow with low speed mode on standby
  - Variable flow based on pressure difference or constant temperature



## TECHNICAL INSIGHTS

### SmartVu™ control

The SmartVu™ control combines intelligence with operating simplicity. The control constantly monitors all machine parameters and precisely manages the operation of compressors, expansion devices, fans and the evaporator water pump for optimum energy efficiency.

The SmartVu™ control features advanced Ethernet-based communication technology (IP) and a user-friendly and intuitive user interface with 4.3-inch colour touch screen.

- Energy management configuration
  - Internal timer: Controls chiller on/off times and operation at a second setpoint
  - Setpoint offset based on the outdoor air temperature
  - Master/slave control of two chillers operating in parallel with runtime balancing and automatic changeover in case of a unit fault.
  - Innovative smart energy monitoring, providing users with smart data such as real-time electrical energy consumption and cooling capacity, and instantaneous and average energy efficiency values.
  - For further energy savings, the AquaSnap® can be monitored remotely by Carrier experts for energy consumption diagnosis and optimisation.
- Integrated features
  - Night mode: Capacity and fan speed limitation for reduced noise level
  - With hydraulic module: Water pressure display and water flow rate calculation.
- Advanced communication features
  - Easy, high-speed communication technology over Ethernet (IP) to a centralised building management system
  - Access to multiple unit parameters.
- Maintenance functions
  - F-Gas regulation leak check reminder alert
  - Maintenance alert can be configured to days, months or hours of operation
  - Storage of maintenance manual, wiring diagram and spare parts list
  - Display of trend curves for the main values
  - Management of a fault memory allowing a log of the last 50 incidents to be accessed, with operating readings taken when the fault occurs
  - Blackbox memory

- 4"3 SmartVu™ user interface



- Intuitive and user-friendly 4"3 inch touch screen interface
- Concise and clear information is available in local languages
- Complete menu, customised for different users (end user, service personnel or Carrier engineers).

### Remote management (standard)

Units with SmartVu™ control can be easily accessed from the internet, using a PC with an Ethernet connection. This makes remote control quick and easy and offers significant advantages for service operations.

The AquaSnap® is equipped with an RS485 serial port that offers multiple remote control, monitoring and diagnostic possibilities. Carrier offers a vast choice of control products, specially designed to control, manage and supervise the operation of an air conditioning system. Please consult your Carrier representative for more information.

The AquaSnap® also communicates with other centralised building management systems via optional communication gateways.

A connection terminal allows the AquaSnap® unit to be remotely controlled by wire:

- Start/stop: Opening of this contact will shut down the unit
- Dual setpoint: closing of this contact activates a second setpoint (e.g.: unoccupied mode).
- Demand limit: Closing of this contact limits the maximum chiller capacity to a predefined value.
- Operation indication: This volt-free contact indicates that the chiller is operating (refrigeration).
- Alarm indication: this volt-free contact indicates the presence of a major fault that has led to the shut-down of one or several refrigerant circuits.

## TECHNICAL INSIGHTS

---

### Energy management module (option)

The Energy Management Module offers extended remote control possibilities:

- Room temperature: enables the setpoint to be reset based on the indoor air temperature of the building (with Carrier thermostat).
- Setpoint reset: the cooling setpoint is reset based on a 4-20 mA signal.
- Demand limit: enables the maximum chiller power to be limited based on a 4-20 mA signal.
- Demand limit 1 and 2: closing of these contacts limits the maximum chiller power or current to two predefined values.
- User safety: this contact can be used for any customer safety loop; opening the contact generates a specific alarm.
- Ice storage end: when ice storage has finished, this input is used to return to the second setpoint (unoccupied mode).
- Time schedule override: closing of this contact cancels the effects of the time schedule.
- Out of service: this signal indicates that the chiller is completely out of service.
- Chiller capacity: this analogue output (0-10 V) gives an immediate indication of the chiller capacity.
- Alert indication: this volt-free contact indicates the need to carry out a maintenance operation or the presence of a minor fault.
- Boiler control: this on/off output controls an independent boiler to provide hot water.

## OPTIONS

Options	No.	Description	Advantages	30RB/RBP 170R-950R	30RQ/RQP 165R-1040R
Corrosion protection, traditional coils	3A	Fins made of pre-treated aluminium (polyurethane and epoxy)	Improved corrosion resistance, recommended for moderate marine and urban environments	No	165R-1040R
Low-temperature brine solution	6B	Low temperature chilled water production down to -8 °C with ethylene or propylene glycol	Covers specific applications such as ice storage and industrial processes	30RBP 170R-950R	No
High-pressure static fans	12	Unit equipped with high-pressure variable-speed static fans (maximum 200 Pa), each fan being equipped with a connection flange for connection to the ducting system.	Ducted fan discharge, optimised fan speed control, based on the operating conditions and system characteristics	30RBP 170R-950R	30RQP 165R-1040R
Very low noise level	15LS	Acoustic compressor enclosure and low-speed fans	Noise level reduction for sensitive sites	170R-950R	165R-1040R
EC fans	17	Unit equipped with EC fans	Improves the unit's energy efficiency	30RBP 170R-950R	30RQP 165R-1040R
Protection grilles	23	Metallic protection grilles	Coil protection against possible impact	170R-950R	165R-1040R
Soft starter per circuit	25E	Soft starter on each circuit	Economical solution for reduced start-up current	170R-950R	165R-1040R
Soft starter per compressor	25	Electronic starter on each compressor	Reduced start-up current	170R-410R	165R-400R / 620R-800R
Water exchanger frost protection	41	Electric heater on the water type heat exchanger and the water duct	Water type heat exchanger module frost protection for an outdoor air temperature between 0 °C and -20 °C	170R-950R	165R-1040R
Water manifold antifreeze protection	41D	Electric heater and insulation on the water collection vessel pipes	Water manifold antifreeze protection down to an outdoor temperature of -20 °C	No	30RQP 620R-1040R
Unit frost protection with Free Cooling Glycol Free option	41E	Electric resistance heater on water exchanger, and hydraulic module	Water exchanger and hydraulic module frost protection down to -20°C outside temperature	170R-950R	No
Exchanger and hydraulic module frost protection	42A	Electrical heaters on the water type heat exchanger, water pipes, hydraulic module and expansion tank	Water type heat exchanger and hydraulic module frost protection down to an outdoor air temperature of -20 °C	170R-950R	165R-1040R
Exchanger and hydraulic frost protection with buffer tank	42B	Electrical heater on the water type heat exchanger, water pipes, hydraulic module and optional expansion tank & buffer tank	Water type heat exchanger and hydraulic module frost protection down to an outdoor air temperature of -20 °C	170R-950R	165R-1040R
Partial heat recovery	49	Unit equipped with one desuperheater on each refrigerant circuit	Production of free high-temperature hot water simultaneously with chilled water production (or hot water for heat pump)	170R-950R	165R-1040R
Total heat recovery	50	Unit equipped with additional heat exchanger in series with the condenser coils.	Production of free hot water, adjustable on demand	30RBP 170R-950R	No
Master/slave operation	58	Unit equipped with supplementary water outlet temperature sensor kit (to be field installed) allowing master/slave operation of two units connected in parallel	Optimised operation of two units connected in parallel operation with runtime balancing	170R-950R	165R-520R
Compressor suction and discharge valves	92A	Shut-off valves on the common compressor suction and discharge pipes	Simplified maintenance. Possibility to store the refrigerant charge in the cooler or condenser side during servicing	170R-950R	165R-1040R
HP single-pump hydraulic module	116R	Single high-pressure water pump. (expansion tank with built-in safety hydraulic components available in option)	Quick and easy installation (plug & play)	170R-550R	165R-520R
HP dual-pump hydraulic module	116S	Dual high-pressure fixed-speed pump. (expansion tank with built-in safety hydraulic components available in option)	Quick and easy installation (plug & play)	170R-550R	165R-520R

## OPTIONS

Options	No.	Description	Advantages	30RB/RBP 170R-950R	30RQ/RQP 165R-1040R
LP single-pump hydraulic module	116T	Single low-pressure fixed-speed pump.(expansion tank with built-in safety hydraulic components available in option)	Quick and easy installation (plug & play)	170R-550R	165R-520R
LP dual-pump hydraulic module	116U	Dual low-pressure water pump Fixed-speed pump, (expansion tank with built-in safety hydraulic components available in option)	Quick and easy installation (plug & play)	170R-550R	165R-520R
Variable-speed single HP pump	116V	Single high-pressure water pump with variable speed drive (VSD), electronic water flow control, pressure transducers. Multiple possibilities of water flow control. (expansion tank not included)	Easy and fast installation (plug & play), significant pumping energy cost savings (up totwo-thirds), tighter water flow control, improved sytem reliability	170R-950R	165R-1040R
Variable-speed dual high-pressure pump.	116W	Dual high-pressure water pump with variable speed drive (VSD), pressure transducers. Multiple possibilities of water flow control (expansion tank with built-in safety hydraulic components available in option)	Easy and fast installation (plug & play), significant pumping energy cost savings (up to two-thirds), tighter water flow control, improved sytem reliability	170R-950R	165R-1040R
High energy efficiency underfloor heating/cooling application	119C	Optimisation of the refrigerant and control circuit for the underfloor heating/cooling system application	Improvement of performances and reduction of energy costs for the underfloor heating/cooling application	No	165R-1040R
Lon communication gateway	148D	Two-directional communication board complying with Lon Talk protocol	Connects the unit by communication BUS to a centralised building management system	170R-950R	165R-1040R
ModBus over IP and RS485 communication gateway	149B	Two-directional high-speed communication using the ModBus over Ethernet network (IP) protocol	Easy, quick connection via Ethernet line to a building technical management system. Allows access to several unit parameters.	170R-950R	165R-1040R
Bacnet over IP	149	Two-directional high-speed communication using BACnet protocol over Ethernet network (IP)	Easy and high-speed connection by Ethernet line to a BMS. Allows access to multiple unit parameters	170R-950R	165R-1040R
Energy management module	156	EMM Control board with additional inputs/outputs. See Energy Management Module section	Extended remote control capabilities (setpoint reset, ice storage end, demand limits, boiler on/off command...)	170R-950R	165R-1040R
Contact for refrigerant leak detection	159	0-10 V signal to report any refrigerant leakage in the unit directly (the leak detector itself must be supplied by the customer)	Immediate customer notification of refrigerant losses to the atmosphere, allowing timely corrective actions	170R-950R	165R-1040R
Phase controller	159B	Phase controller on the power supply	Reinforced protection of the compressors by monitoring rotation, the absence and asymmetry of the phases, and the over- or under-voltage of the electricity network	170R-950R	165R-1040R
Compliance with Russian regulations	199	EAC certification	Compliance with Russian regulations	170R-950R	165R-1040R
Coil defrost resistance heaters	252	Electric heaters under the coils and the condensate pans	Prevents frost formation on the coils; compulsory in heating mode if the outdoor temperature is below 0 °C	No	165R-1040R
Insulation of the evaporator inlet/outlet refrigerant lines	256	Thermal insulation of the evaporator inlet/outlet refrigerant lines, with UV-resistant flexible connection and insulation	Prevents condensation on the evaporator inlet/outlet refrigerant lines	170R-950R	165R-1040R



## OPTIONS

Options	No.	Description	Advantages	30RB/RBP 170R-950R	30RQ/RQP 165R-1040R
Enviro-Shield anti-corrosion protection®	262	Coating applied using a conversion process which modifies the surface of the aluminium producing a coating that is integral to the coil. Complete immersion in a bath to ensure 100% coverage. Minimal heat transfer variation, tested to withstand more than 4000 hours of salt spray as per ASTM B117	Improved corrosion resistance, recommended for use in moderately corrosive environments	170R-950R	No
Anticorrosion coating on Free Cooling option coils	262ABC	Same anticorrosion treatment as on MCHE condenser coils	Improved corrosion resistance, recommended for use in extremely corrosive environments	170R-950R	No
Super Enviro-Shield anti-corrosion protection®	263	Extremely durable and flexible epoxy polymer coating applied by electro coating process, final UV protective topcoat. Minimal heat transfer variation, tested to withstand more than 6000 hours of constant neutral salt spray as per ASTM B117, improved impact resistance as per ASTM D2794	Improved corrosion resistance, recommended for use in extremely corrosive environments	170R-950R	No
Welded evaporator connection kit	266	Victaulic piping connections with welded joints	Easy installation	170R-950R	165R-1040R
Compressor enclosure	279a	Compressor with enclosure	Improved aesthetics, compressor protection against external elements (dust, sand, water...)	170R-950R	165R-1040R
EMC class. C2, as per EN 61800-3	282	Additional RFI filters on the unit power line	Reduces electromagnetic interferences in compliance with the emissions level required in category C2 to enable it to be used in the first environment ("residential environment")	170R-950R	165R-1040R
230 V electrical plug	284	230 VAC power source provided with plug socket and transformer (180 VA, 0.8 A)	Enables connection of a laptop or an electrical device during system start-up or maintenance	170R-950R	165R-1040R
Expansion tank	293	6-bar expansion tank built into the hydraulic module (requires hydraulic module option)	Easy and fast installation (plug & play), & protection of closed water systems from excessive pressure	170R-950R	165R-1040R
Electric energy meter	294	Electric energy meter. Display of energy consumption, instantaneous (U, V, I) and cumulative (kWh), on the machine interface, data available on the communication bus	Permits the acquisition and monitoring (remotely via the CMS/BMS) of the energy used.	170R-950R	165R-1040R
Ultra fast capacity recovery	295+	Built-in capacity module to allow an ultra-rapid restart whilst maintaining the unit's reliability.	Full capacity recovery in less than 2.5 minutes after a power failure lasting less than ten minutes. Matches requirements of typical critical mission applications. (process, data centres)	30RBP 170R-950R	No
Screwed water connection sleeves for desuperheater	303	DSH connections with screw connection sleeves	Easy to install. Allows unit connection to a screw connector	170R-950R	165R-1040R
Welded connection sleeve for desuperheater	304	DSH inlet/outlet welded connection sleeves	Easy installation	170R-950R	165R-1040R
Free cooling (total)	305A	Free cooling hydraulic coils on the two refrigerant circuits	Energy savings for applications which require cooling all year round (e.g.: industrial processes, data centres)	30RBP 170R-950R	No
Free cooling (partial)	305B	Free cooling hydraulic coils on a refrigerant circuit	Energy savings for applications with reduced demand for cooling in the winter (e.g. office space with computer room, meeting rooms)	30RBP 170R-950R	No
Free Cooling Glycol-Free (Total)	305C	Free cooling hydraulic coils on both refrigerant circuits and decoupling exchanger.	Energy savings for applications which require cooling all year round (e.g.: industrial processes, data centres, etc.) Glycol-free operation	30RBP 170R-950R	No
Water buffer tank module	307	Built-in water buffer tank module	Avoids short cycle on compressors and ensures stable water in the loop	170R-950R	165R-1040R
Free cooling dry cooler management	313	Control & connections to a Free Cooling Drycooler 09PE or 09VE fitted with option FC control box	Easy system management, control capabilities extended to a dry cooler used in Free Cooling mode	170R-950R	No

## OPTIONS

Options	No.	Description	Advantages	30RB/RBP 170R-950R	30RQ/RQP 165R-1040R
Compliance with UAE regulations	318	Additional label on the unit with input power, current and EER under rated conditions in accordance with AHRI 550/590	Compliance with ESMA standard UAE 5010-5:2016.	170R-950R	No
Compliance with Qatar regulations	319	Specific name plate on the unit with 415 V +/-6% power supply	Compliance with KAHRAMAA regulations in Qatar	170R-950R	No
Water manifold	325A	Pipe system ensuring a single hydraulic connection point	Easy installation	No	620R-1040R
Installation or application process outside Europe	326	Specific management of option compatibility	Permits non-standard option compatibility for HVAC application in the EU	30RB 170R-380R 30RBP 170R-950R	No
Compliance with Moroccan regulations	327	Specific regulatory documentation	Compliance with Moroccan regulations	170R-950R	165R-1040R
Delivered wrapped in plastic film	331	Unit wrapped in a plastic cover and strapped onto a wooden pallet.	Protects against dust and external soiling of the unit during storage and transport.	170R-950R	165R-1040R



## FREE COOLING SYSTEM (OPTION 305A – 305B – 305C)

Reducing operating costs and protecting the environment have become the key concerns, both for air conditioning applications, and for industrial processes and cooling data centres.

The free cooling option allows significant energy savings to be made in all applications that require cooling throughout the year, particularly when used in colder climates. In these regions, free cooling can be used to fulfil a large proportion of the cooling requirements both economically and in a way that respects the environment.

In free cooling mode, the compressors are stopped, and only the fans are in operation. The SmartVu™ control automatically switches from compressor cooling mode to free cooling mode depending on the chiller heat load and the temperature differential between the chilled water outlet and the ambient air.

**Important: To optimise cooler performance, you are recommended to use the leaving water temperature setpoint offset function.**

### Operating principle

The unit's SmartVu™ control maximises the use of the free cooling based on the needs of the application and the climate conditions. Once the chilled water/ambient air temperature differential exceeds the threshold value by 1K (2K on the Glycol Free version), the SmartVu™ control activates free cooling and adjusts the air flow rate to optimise the unit's energy performance. If the operating conditions permit the free cooling to operate on its own to meet the requirements, the compressors are stopped. Two motorised valves direct the chilled water to the free cooling coils.

### Three operating modes are possible:

#### Summer (warm weather season): Mechanical cooling mode

The liquid chiller meets the needs traditionally using the refrigerant circuit. The fluid bypasses the free cooling coils and is cooled by the evaporator.

#### Mid-season: Combination mode

It is possible to operate in combination free cooling and mechanical cooling mode. This helps optimise free cooling operations while covering the system's cooling requirements. The fluid is pre-cooled by the free cooling coils positioned in series with the refrigerant circuit evaporator which finalises cooling of the fluid.

#### Winter (cold weather season): Free cooling mode

Depending on the capacity requested and the setpoint, all of the requirements may be fulfilled by the free cooling in this operating mode without the fans running, thereby ensuring optimum energy efficiency.

### Adaptations to requirements

Depending on the requirements of the user, the AquaSnap free cooling is available with 3 performance levels:

- 305A total hydraulic free cooling on the 2 circuits, specifically designed for installations which have major cooling requirements all year round (industrial processes, data centres)
- 305C, Total Hydraulic Free-Cooling, Glycol-Free version, enables the use of pure water in the cooling circuit.
- 305B partial hydraulic free cooling on 1 circuit, designed for installations which have limited cooling requirements during the winter (offices, hospitals, etc.)

### Advantages of the built-in free cooling system

- The free cooling function is independent of the refrigerant circuit, which increases reliability and facilitates maintenance compared to free cooling built into the refrigerant circuit (DX FC).
- The Hydraulic Free Cooling design is intended to expand the scope of application compared to the Free Cooling refrigerant concept (DX FC) by enabling Free Cooling mode to be activated by a higher outdoor temperature, thereby allowing for greater energy savings.
- The built-in Hydraulic Free Cooling version developed based on the AquaSnap® range allows all of the advantages of a free cooling solution to be combined with the compact design of the base units.

### Advantage of the Free Cooling Glycol-Free system

In applications or countries in which the use of glycol is strictly regulated or banned, the Free Cooling Glycol-Free option is equipped with a separation heat exchanger, and only the circuit inside the unit contains glycol, while the user circuit contains pure water.

This solution with an intermediate exchanger shifts the Free Cooling mode activation thresholds by a few degrees, and the heat exchangers selected by Carrier help to minimise this shift.



## FREE COOLING SYSTEM (OPTION 305A – 305B)

### Physical properties of 30RBP units with the Free Cooling option

30RBP		170R	190R	210R	230R	270R	310R	340R	380R	410R	450R			
<b>Cooling</b>														
Standard unit Full load performances*	CA1	Maximum rated capacity	kW		181	198	220	239	288	328	366	401	440	475
		EER	kW/kW		3,28	3,46	3,31	3,25	3,12	3,23	3,16	3,21	3,16	3,22
<b>FREE COOLING</b>														
Total free cooling option (305A)	CFC1	Maximum rated capacity	kW		182	243	243	243	243	303	303	364	364	425
		Free cooling EER	kW/kW		25,86	25,43	25,43	25,43	25,76	25,76	25,94	25,55	25,71	26,07
		Rate of coverage by free cooling	%		101%	122%	110%	102%	84%	93%	83%	91%	83%	89%
		Outdoor temperature for 100% coverage by free cooling	°C		0,1	2,3	1,2	0,2	-2,3	-1,0	-2,6	-1,3	-2,6	-1,5
		Pressure drops	kPa		94	112	112	112	102	107	101	117	112	103
		Sound power <sup>(1)</sup>	dB(A)		88,0	89,0	89,0	89,0	89,0	90,0	90,0	90,5	91,0	91,0
		Sound pressure at 10 m <sup>(2)</sup>	dB(A)		69,0	70,5	70,5	70,5	70,5	70,5	70,5	71,0	71,5	71,0
Partial free cooling option (305B)	CFC1	Maximum rated capacity	kW		121	121	121	121	121	121	121	145	145	182
		Free cooling EER	kW/kW		25,78	25,78	25,78	25,78	25,87	25,97	26,00	19,15	19,14	26,46
		Rate of coverage by free cooling	%		67%	61%	55%	51%	42%	37%	33%	36%	33%	38%
		Pressure drops	kPa		80	80	80	80	77	75	74	81	79	75
		Sound power <sup>(1)</sup>	dB(A)		86,0	86,0	86,0	86,0	86,0	86,0	86,0	87,5	88,0	87,5
		Sound pressure at 10 m <sup>(2)</sup>	dB(A)		67,5	67,5	67,5	67,5	67,5	66,5	66,5	68,0	68,5	67,5
Unit + option 15LS <sup>(3)</sup> Full load performances*	CA1	Maximum rated capacity	kW		171	189	208	226	270	309	343	377	413	447
		EER	kW/kW		3,06	3,29	3,08	3,03	2,82	2,96	2,85	2,94	2,86	2,94
<b>FREE COOLING</b>														
Total free cooling option (305A)	CFC1	Maximum rated capacity	kW		148	197	197	197	197	247	247	296	296	345
		Free cooling EER	kW/kW		39,92	39,76	39,76	39,76	40,28	40,58	41,01	40,14	40,52	41,39
		Rate of coverage by free cooling	%		87%	104%	95%	87%	73%	80%	72%	79%	72%	77%
		Outdoor temperature for 100% coverage by free cooling	°C		-2,0	0,5	-0,8	-1,9	-4,8	-3,3	-5,1	-3,6	-5,1	-3,8
		Pressure drops	kPa		65	77	77	77	71	73	70	80	77	71
		Sound power <sup>(1)</sup>	dB(A)		79,5	80,5	80,5	80,5	81,0	82,0	82,0	82,0	82,5	82,5
		Sound pressure at 10 m <sup>(2)</sup>	dB(A)		60,5	62,0	62,0	62,0	62,5	63,0	63,0	62,5	63,0	62,5
Partial free cooling option (305B)	CFC1	Maximum rated capacity	kW		98	98	98	98	99	99	99	118	118	148
		Free cooling EER	kW/kW		42,39	42,39	42,39	42,39	42,73	43,05	43,17	30,35	30,48	43,20
		Rate of coverage by free cooling	%		58%	52%	47%	44%	37%	32%	29%	31%	29%	33%
		Pressure drops	kPa		55	55	55	55	54	52	51	56	55	52
		Sound power <sup>(1)</sup>	dB(A)		77,5	77,5	77,5	77,5	78,0	78,0	78,0	79,0	79,5	79,0
		Sound pressure at 10 m <sup>(2)</sup>	dB(A)		59,0	59,0	59,0	59,0	59,5	59,0	59,5	60,0	59,0	

\* In accordance with EN14511-3:2022.

CA1 Cooling mode conditions: evaporator water inlet/outlet temperature 17 °C/10 °C, outdoor air temperature at 35 °C, 30% Mono-Ethylene-Glycol, evaporator fouling factor 0 m<sup>2</sup>. k/W

CFC1 Free cooling mode conditions: evaporator water inlet/outlet temperature 17 °C/10 °C, outdoor air temperature at 0 °C, 30% Mono-Ethylene-Glycol, evaporator fouling factor 0 m<sup>2</sup>. k/W

(1) In dB ref=10<sup>-12</sup> W, (A) weighting. Declared dual-number noise emission value in accordance with ISO 4871 with an uncertainty of +/-3 dB(A). Measured in accordance with ISO 9614-1 and certified by Eurovent.

(2) In dB ref 20 µPa, (A) weighting. Declared dual-number noise emission value in accordance with ISO 4871 with an uncertainty of +/-3 dB(A). For information, calculated from the sound power Lw(A).

(3) Options: 15LS = Very low noise level, 116V = Variable speed high pressure single-pump hydraulic module,





**FREE COOLING SYSTEM (OPTION 305A – 305B)**

30RBP	170R	190R	210R	230R	270R	310R	340R	380R	410R	450R
<b>Total Free Cooling - Option 305A</b>										
<b>Free cooling coil</b>	All-aluminium micro-channel coils (MCHE)									
Quantity	3	4	4	4	4	5	5	6	6	7
<b>Hydraulic connection</b>										
Connection	in	3"	3"	3"	3"	3"	4"	4"	4"	4"
External diameter	mm	88,9	88,9	88,9	88,9	88,9	114,3	114,3	114,3	114,3
Additional water volume	l	60	72	72	72	72	113	113	126	126
<b>Weight<sup>(4)</sup></b>										
Additional weight (without water)	kg	225	266	266	266	266	357	359	395	397
Additional weight (during operation)	kg	287	341	341	341	341	475	477	526	528
<b>Operation</b>										
Max. operating pressure, water side	bar	6	6	6	6	6	6	6	6	6
<b>Partial Free Cooling - Option 305B</b>										
<b>Free cooling coil</b>	All-aluminium micro-channel coils (MCHE)									
Quantity	2	2	2	2	2	2	2	3	3	3
<b>Hydraulic connection</b>										
Connection	in	3"	3"	3"	3"	3"	4"	4"	4"	4"
External diameter	mm	88,9	88,9	88,9	88,9	88,9	114,3	114,3	114,3	114,3
Additional water volume	l	48	48	48	48	48	58	58	75	75
<b>Weight<sup>(4)</sup></b>										
Additional weight (without water)	kg	178	178	178	178	179	210	212	248	250
Additional weight (during operation)	kg	227	227	227	227	228	271	273	326	328
<b>Operation</b>										
Max. operating pressure, water side	bar	6	6	6	6	6	6	6	6	6

(4) Values are guidelines only. Refer to the unit name plate.



## FREE COOLING SYSTEM (OPTION 305A – 305B)

30RBP			480R	550R	610R	670R	720R	770R	800R	870R	950R	
<b>Cooling</b>												
<b>Standard unit</b> Full load performances*	CA1	Maximum rated capacity	kW	512	585	652	718	767	827	852	932	994
		EER	kW/kW	3,16	3,15	3,23	3,22	3,12	3,14	3,10	3,06	2,96
<b>FREE COOLING</b>												
Total free cooling option (305A)	CFC1	Maximum rated capacity	kW	425	485	546	607	607	667	667	728	728
		Free cooling EER	kW/kW	26,12	25,96	25,99	25,77	25,77	25,65	25,65	25,41	25,41
		Rate of coverage by free cooling	%	83%	83%	84%	84%	79%	81%	78%	78%	73%
		Outdoor temperature for 100% coverage by free cooling	°C	-2,6	-2,6	-2,4	-2,3	-3,3	-3,0	-3,5	-3,5	-4,6
		Pressure drops	kPa	102	110	111	120	120	126	126	136	136
		Sound power <sup>(1)</sup>	dB(A)	91,0	91,5	92,5	93,0	93,0	93,0	93,0	93,5	94,0
		Sound pressure at 10 m <sup>(2)</sup>	dB(A)	71,0	71,5	72,0	72,5	72,5	72,0	72,0	72,5	73,0
Partial free cooling option (305B)	CFC1	Maximum rated capacity	kW	182	242	204	262	262	303	303	364	364
		Free cooling EER	kW/kW	26,46	26,58	20,36	20,91	20,91	26,66	26,66	26,57	26,57
		Pressure drops	kPa	75	79	77	82	82	80	80	86	86
		Sound power <sup>(1)</sup>	dB(A)	87,5	88,5	89,0	90,0	90,0	89,5	89,5	90,5	91,0
		Sound pressure at 10 m <sup>(2)</sup>	dB(A)	67,5	68,5	68,5	69,5	69,5	68,5	68,5	69,5	70,0
<b>Unit + option 15LS<sup>(3)</sup></b> Full load performances*	CA1	Maximum rated capacity	kW	481	549	613	677	719	777	798	873	925
		EER	kW/kW	2,85	2,85	2,94	2,94	2,82	2,84	2,79	2,76	2,63
<b>FREE COOLING</b>												
Total free cooling option (305A)	CFC1	Maximum rated capacity	kW	345	395	444	493	493	543	543	592	592
		Free cooling EER	kW/kW	41,49	41,14	41,23	40,73	40,73	40,47	40,47	39,92	39,92
		Rate of coverage by free cooling	%	72%	72%	72%	73%	69%	70%	68%	68%	64%
		Outdoor temperature for 100% coverage by free cooling	°C	-5,1	-5,1	-5,0	-4,8	-5,9	-5,6	-6,1	-6,2	-7,3
		Pressure drops	kPa	70	75	76	82	82	86	86	93	93
		Sound power <sup>(1)</sup>	dB(A)	83,0	83,5	85,0	85,0	85,0	85,5	84,5	85,5	86,0
		Sound pressure at 10 m <sup>(2)</sup>	dB(A)	63,0	63,5	64,0	64,5	64,5	64,5	63,5	64,5	65,0
Partial free cooling option (305B)	CFC1	Maximum rated capacity	kW	148	197	166	213	213	247	247	296	296
		Free cooling EER	kW/kW	43,24	43,63	32,85	34,02	34,02	44,19	44,19	44,26	44,26
		Rate of coverage by free cooling	%	31%	36%	27%	31%	30%	32%	31%	34%	32%
		Pressure drops	kPa	52	55	53	56	56	56	56	59	59
		Sound power <sup>(1)</sup>	dB(A)	79,5	80,5	81,0	82,0	82,0	82,0	81,0	82,5	83,0
		Sound pressure at 10 m <sup>(2)</sup>	dB(A)	59,5	60,5	60,5	61,5	61,5	61,0	60,0	61,5	62,0

\* In accordance with EN14511-3:2022.

CA1 Cooling mode conditions: evaporator water inlet/outlet temperature 17 °C/10 °C, outdoor air temperature at 35 °C, 30% Mono-Ethylene-Glycol, evaporator fouling factor 0 m<sup>2</sup>. k/W

CFC1 Free cooling mode conditions: evaporator water inlet/outlet temperature 17 °C/10 °C, outdoor air temperature at 0 °C, 30% Mono-Ethylene-Glycol, evaporator fouling factor 0 m<sup>2</sup>. k/W

(1) In dB ref=10<sup>-12</sup> W, (A) weighting. Declared dual-number noise emission value in accordance with ISO 4871 with an uncertainty of +/-3 dB(A). Measured in accordance with ISO 9614-1 and certified by Eurovent.

(2) In dB ref 20 µPa, (A) weighting. Declared dual-number noise emission value in accordance with ISO 4871 with an uncertainty of +/-3 dB(A). For information, calculated from the sound power Lw(A).

(3) Options: 15LS = Very low noise level, 116V = Variable speed high pressure single-pump hydraulic module.



**FREE COOLING SYSTEM (OPTION 305A – 305B)**

30RBP	480R	550R	610R	670R	720R	770R	800R	870R	950R
<b>Total Free Cooling - Option 305A</b>									
<b>Free cooling coil</b>	All-aluminium micro-channel coils (MCHE)								
Quantity	7	8	9	10	10	11	11	12	12
<b>Hydraulic connection</b>									
Connection	in	4"	4"	5"	5"	5"	5"	5"	5"
External diameter	mm	114,3	114,3	139,7	139,7	139,7	139,7	139,7	139,7
Additional water volume	l	200	213	298	310	310	351	351	364
<b>Weight<sup>(4)</sup></b>									
Additional weight (without water)	kg	515	556	662	700	700	814	814	851
Additional weight (during operation)	kg	724	778	972	1023	1023	1180	1180	1230
<b>Operation</b>									
Max. operating pressure, water side	bar	6	6	6	6	6	6	6	6
<b>Partial Free Cooling - Option 305B</b>									
<b>Free cooling coil</b>	All-aluminium micro-channel coils (MCHE)								
Quantity	3	4	4	5	5	5	5	6	6
<b>Hydraulic connection</b>									
Connection	in	4"	4"	5"	5"	5"	5"	5"	5"
External diameter	mm	114,3	114,3	139,7	139,7	139,7	139,7	139,7	139,7
Additional water volume	l	101	120	186	198	198	205	205	224
<b>Weight<sup>(4)</sup></b>									
Additional weight (without water)	kg	305	346	406	443	443	499	499	536
Additional weight (during operation)	kg	410	471	600	650	650	713	713	770
<b>Operation</b>									
Max. operating pressure, water side	bar	6	6	6	6	6	6	6	6

(4) Values are guidelines only. Refer to the unit name plate.



## GLYCOL-FREE FREE COOLING SYSTEM (OPTION 305C)

30RBP		170R	190R	210R	230R	270R	310R	340R	380R	410R	450R		
<b>Cooling</b>													
Standard unit Full load performances*	CA2	Maximum rated capacity	kW	226	247	277	298	364	409	461	502	553	598
		EER	kW/kW	3,65	3,87	3,64	3,60	3,35	3,52	3,39	3,49	3,38	3,50
<b>FREE COOLING</b>													
Glycol-free total free cooling option (305C)	CFC2	Maximum rated capacity	kW	264,10	341,93	341,93	341,93	341,92	440,37	440,17	516,21	516,24	617,18
		Free cooling EER	kW/kW	25,76	24,97	24,97	24,97	25,64	24,85	25,22	24,67	24,99	24,89
		Rate of coverage by free cooling	%	117%	139%	123%	115%	94%	108%	96%	103%	93%	103%
		Outdoor temperature for 100% coverage by free cooling	°C	3,30	6,40	4,40	3,00	-1,50	1,60	-1,00	0,70	-1,60	0,70
		Pressure drops	kPa	87,25	141,24	141,24	141,24	121,60	113,45	102,00	140,77	130,72	117,53
		Sound power <sup>(1)</sup>	dB(A)	88,0	89,0	89,0	89,0	89,0	90,0	90,0	90,5	91,0	91,0
		Sound pressure at 10 m <sup>(2)</sup>	dB(A)	69,5	70,5	70,5	70,5	70,5	70,5	70,5	71,0	71,5	71,0
Unit + option 15LS <sup>(3)</sup> Full load performances*	CA2	Maximum rated capacity	kW	205	227	253	270	328	370	415	454	500	541
		EER	kW/kW	3,12	3,43	3,13	3,08	2,76	2,96	2,79	2,92	2,78	2,92
<b>FREE COOLING</b>													
Glycol-free total free cooling option (305C)	CFC2	Maximum rated capacity	kW	215,64	281,76	281,76	281,76	281,73	359,09	358,84	423,72	423,78	502,60
		Free cooling EER	kW/kW	27,61	28,14	28,14	28,14	28,97	26,44	26,84	27,21	27,58	26,44
		Rate of coverage by free cooling	%	105%	124%	111%	104%	86%	97%	86%	93%	85%	93%
		Outdoor temperature for 100% coverage by free cooling	°C	1,10	4,50	2,30	0,90	-3,90	-0,70	-3,60	-1,70	-4,20	-1,70
		Pressure drops	kPa	59,79	98,40	98,40	98,40	84,59	77,22	69,28	96,87	89,86	79,66
		Sound power <sup>(1)</sup>	dB(A)	80,0	81,0	81,0	81,0	81,5	82,5	82,5	82,5	83,0	83,0
		Sound pressure at 10 m <sup>(2)</sup>	dB(A)	61,0	62,5	62,5	62,5	63,0	63,0	63,0	62,5	63,0	63,0
<b>Total glycol-free free cooling - Option 305C</b>													
<b>Free cooling coil</b>													
Quantity		All-aluminium micro-channel coils (MCHE)											
		3	4	4	4	4	5	5	6	6	7		
<b>Hydraulic connection</b>													
Connection		in	3"	3"	3"	3"	3"	3"	3"	3"	3"	4"	
External diameter		mm	88,9	88,9	88,9	88,9	88,9	88,9	88,9	88,9	88,9	114,3	
Additional water volume		l	51	51	51	51	51	82	82	80	80	106	
<b>Dimensions</b>													
Additional length		mm	1194	1194	1194	1194	1194	1194	1194	1194	1194	1194	
<b>Weight<sup>(4)</sup></b>													
Additional weight (without water)		kg	867	921	921	922	926	1105	1115	1161	1169	1427	
Additional weight (during operation)		kg	918	973	973	973	977	1187	1197	1241	1248	1533	
<b>Operation</b>													
Max. operating pressure, water side		bar	6	6	6	6	6	6	6	6	6	6	

\* In accordance with EN14511-3:2022.

CA2 Cooling mode conditions: evaporator water inlet/outlet temperature 26°C/20°C, outdoor air temperature at 35 °C, evaporator fouling factor 0 m<sup>2</sup>. k/W

CFC2 Free cooling mode conditions: evaporator water inlet/outlet temperature 26°C/20°C, outdoor air temperature at 0 °C, evaporator fouling factor 0 m<sup>2</sup>. k/W

(1) In dB ref=10<sup>-12</sup> W, (A) weighting. Declared dual-number noise emission value in accordance with ISO 4871 with an uncertainty of +/-3 dB(A). Measured in accordance with ISO 9614-1 and certified by Eurovent.

(2) In dB ref 20 µPa, (A) weighting. Declared dual-number noise emission value in accordance with ISO 4871 with an uncertainty of +/-3 dB(A). For information, calculated from the sound power Lw(A).

(3) Options: 15LS = Very low noise level, 116V ,

(4) Values are guidelines only. Refer to the unit name plate.



**GLYCOL-FREE FREE COOLING SYSTEM (OPTION 305C)**

30RBP		480R	550R	610R	670R	720R	770R	800R	870R	950R		
<b>Cooling</b>												
<b>Standard unit Full load performances*</b>	CA2	Maximum rated capacity	kW	646	738	798	883	935	1013	1040	1136	1204
		EER	kW/kW	3,39	3,38	3,40	3,41	3,25	3,28	3,22	3,16	3,00
<b>FREE COOLING</b>												
Glycol-free total free cooling option CFC2 (305C)		Maximum rated capacity	kW	617,18	694,77	789,36	866,14	866,14	968,24	968,24	1046,27	1046,27
		Free cooling EER	kW/kW	24,97	24,81	24,22	24,06	24,06	23,05	23,05	22,90	22,90
		Rate of coverage by free cooling	%	96%	94%	99%	98%	93%	96%	93%	92%	87%
		Outdoor temperature for 100% coverage by free cooling	°C	-1,00	-1,40	-0,20	-0,40	-1,80	-1,00	-1,70	-1,90	-3,40
		Pressure drops	kPa	114,76	138,86	122,90	146,49	146,49	148,78	148,78	172,42	172,42
		Sound power <sup>(1)</sup>	dB(A)	91,0	92,0	93,0	93,5	93,5	93,5	93,5	93,5	94,0
		Sound pressure at 10 m <sup>(2)</sup>	dB(A)	71,0	71,5	72,0	72,5	72,5	72,0	72,0	72,5	73,0
<b>Unit + option 15LS<sup>(3)</sup> Full load performances*</b>	CA2	Maximum rated capacity	kW	582	666	719	797	840	826	924	850	900
		EER	kW/kW	2,79	2,78	2,84	2,85	2,69	3,06	2,69	3,28	3,09
<b>FREE COOLING</b>												
Glycol-free total free cooling option CFC2 (305C)		Maximum rated capacity	kW	502,61	568,29	643,32	708,58	708,58	787,74	787,74	853,58	853,58
		Free cooling EER	kW/kW	26,54	27,09	25,39	25,81	25,81	23,73	23,73	24,01	24,01
		Rate of coverage by free cooling	%	86%	85%	89%	89%	84%	95%	85%	100%	95%
		Outdoor temperature for 100% coverage by free cooling	°C	-3,60	-4,00	-2,70	-2,90	-4,30	-1,10	-3,90	0,10	-1,20
		Pressure drops	kPa	77,75	94,79	83,48	100,21	100,21	100,52	100,52	117,09	117,09
		Sound power <sup>(1)</sup>	dB(A)	83,5	84,0	85,5	86,0	86,0	87,0	86,0	87,0	87,5
		Sound pressure at 10 m <sup>(2)</sup>	dB(A)	63,5	64,0	65,0	65,5	65,5	66,0	65,0	66,0	66,5
<b>Total glycol-free free cooling - Option 305C</b>												
<b>Free cooling coil</b>												
		All-aluminium micro-channel coils (MCHE)										
Quantity		7	8	9	10	10	11	11	12	12		
<b>Hydraulic connection</b>												
Connection		in	4"	4"	5"	5"	5"	5"	5"	5"		
External diameter		mm	114,3	114,3	139,7	139,7	139,7	139,7	139,7	139,7		
Additional water volume		l	106	104	157	157	157	199	199	199		
<b>Dimensions</b>												
Additional length		mm	1194	1194	1194	1194	1194	1194	1194	1194		
<b>Weight<sup>(4)</sup></b>												
Additional weight (without water)		kg	1430	1488	1750	1797	1797	2018	2018	2070		
Additional weight (during operation)		kg	1536	1592	1907	1954	1954	2218	2218	2269		
<b>Operation</b>												
Max. operating pressure, water side		bar	6	6	6	6	6	6	6	6		

\* In accordance with EN14511-3:2022.

CA2 Cooling mode conditions: evaporator water inlet/outlet temperature 26°C/20°C, outdoor air temperature at 35 °C, evaporator fouling factor 0 m<sup>2</sup>. kW

CFC2 Free cooling mode conditions: evaporator water inlet/outlet temperature 26°C/20°C, outdoor air temperature at 0 °C, evaporator fouling factor 0 m<sup>2</sup>. kW

(1) In dB ref=10<sup>-12</sup> W, (A) weighting. Declared dual-number noise emission value in accordance with ISO 4871 with an uncertainty of +/-3 dB(A). Measured in accordance with ISO 9614-1 and certified by Eurovent.

(2) In dB ref 20 µPa, (A) weighting. Declared dual-number noise emission value in accordance with ISO 4871 with an uncertainty of +/-3 dB(A). For information, calculated from the sound power Lw(A).

(3) Options: 15LS = Very low noise level, 116V ,

(4) Values are guidelines only. Refer to the unit name plate.



## FREE COOLING SYSTEM (OPTION 305A – 305B – 305C)

### Operating limits

#### 30RBP 170R-950R units

Water-cooled heat exchanger		Minimum	Maximum
Water inlet temperature at start-up	°C	8	40
Water outlet temperature during operation	°C	5	20
Air-cooled exchanger		Minimum	Maximum
Outdoor ambient operating temperature			
30RBP units - Full load	°C	-20	47
30RBP units - Part load	°C	-20	52 <sup>(1)</sup>

(1) Part load operation permitted above an outdoor air temperature of 47 °C. Contact the manufacturer to select a unit using the Carrier electronic catalogue.

All the free cooling units must be protected against freezing with 30% ethylene glycol in the cooling loop circuit (recommended value).

PHYSICAL DATA, SIZES 170R TO 380R

30RB		170R	190R	210R	230R	270R	310R	340R	380R	
<b>Cooling</b>										
<b>Standard unit</b> Full load performances* CA1	Nominal capacity	kW	172	188	207	227	270	311	346	380
	EER	kW/kW	3,20	3,31	3,17	3,17	3,03	3,15	3,09	3,14
Seasonal energy efficiency**	<b>SEER<sub>12/7°C</sub> Comfort low temp.</b>	<b>kWh/kWh</b>	<b>4,28</b>	<b>4,35</b>	<b>4,28</b>	<b>4,24</b>	<b>4,26</b>	<b>4,43</b>	<b>4,44</b>	<b>4,25</b>
	$\eta_s$ cool <sub>12/7°C</sub>	%	<b>168</b>	<b>171</b>	<b>168</b>	<b>167</b>	<b>167</b>	<b>174</b>	<b>175</b>	<b>167</b>
	<b>SEER<sub>23/18°C</sub> Comfort medium temp.</b>	<b>kWh/kWh</b>	<b>5,17</b>	<b>5,32</b>	<b>5,13</b>	<b>5,07</b>	<b>4,97</b>	<b>5,31</b>	<b>5,29</b>	<b>5,12</b>
	SEPR <sub>23/18°C</sub> Process high temp.	kWh/kWh	5,21	5,25	5,19	5,10	5,10	5,32	5,37	5,39
	<b>SEPR<sub>-2/-8°C</sub> Process medium temp.</b>	<b>kWh/kWh</b>	<b>3,09</b>	<b>3,13</b>	<b>3,11</b>	<b>3,02</b>	<b>3,08</b>	<b>3,02</b>	<b>3,07</b>	<b>3,02</b>
Part Load integrated values	IPLV.IP	Btu/Wh	16,58	16,99	16,55	16,62	16,58	17,09	17,16	16,82
Part Load integrated values	IPLV.SI	kW/kW	4,83	4,95	4,82	4,84	4,81	4,97	4,98	4,89
<b>Unit + option 15LS</b> Full load performances* CA1	Nominal capacity	kW	165	180	198	217	256	296	328	361
	EER	kW/kW	3,05	3,24	3,04	3,02	2,81	2,96	2,86	2,94
Seasonal energy efficiency**	<b>SEER<sub>12/7°C</sub> Comfort low temp.</b>	<b>kWh/kWh</b>	<b>4,49</b>	<b>4,64</b>	<b>4,45</b>	<b>4,47</b>	<b>4,35</b>	<b>4,70</b>	<b>4,67</b>	<b>4,62</b>
	$\eta_s$ cool <sub>12/7°C</sub>	%	<b>177</b>	<b>183</b>	<b>175</b>	<b>176</b>	<b>171</b>	<b>185</b>	<b>184</b>	<b>182</b>
	<b>SEER<sub>23/18°C</sub> Comfort medium temp.</b>	<b>kWh/kWh</b>	<b>5,27</b>	<b>5,52</b>	<b>5,22</b>	<b>5,26</b>	<b>4,99</b>	<b>5,66</b>	<b>5,55</b>	<b>5,43</b>
	SEPR <sub>23/18°C</sub> Process high temp.	kWh/kWh	5,27	5,42	5,34	5,19	5,14	5,44	5,47	5,60
	<b>SEPR<sub>-2/-8°C</sub> Process medium temp.</b>	<b>kWh/kWh</b>	<b>3,06</b>	<b>3,11</b>	<b>3,08</b>	<b>3,00</b>	<b>3,04</b>	<b>3,09</b>	<b>3,14</b>	<b>3,09</b>
<b>Sound levels</b>										
<b>Standard unit</b>										
Sound power <sup>(1)</sup>	dB(A)	91,0	91,5	91,5	92,0	92,0	93,0	93,0	93,5	
Sound pressure at 10 m <sup>(2)</sup>	dB(A)	58,5	59,5	59,5	60,0	60,0	60,5	60,5	61,0	
<b>Unit + option 15LS<sup>(3)</sup></b>										
Sound power <sup>(1)</sup>	dB(A)	85,5	85,5	85,5	86,5	86,5	87,5	87,5	88,0	
Sound pressure at 10 m <sup>(2)</sup>	dB(A)	53,0	53,5	53,5	54,5	54,5	55,5	55,5	55,5	
<b>Dimensions - standard unit</b>										
<b>Standard unit</b>										
Length	mm	2410	2410	2410	2410	2410	3604	3604	3604	
Width	mm	2253	2253	2253	2253	2253	2253	2253	2253	
Height	mm	2324	2324	2324	2324	2324	2324	2324	2324	
<b>Unit + option 307<sup>(3)</sup></b>										
Length	mm	3604	3604	3604	3604	3604	4798	4798	4798	
<b>Operating weight<sup>(4)</sup></b>										
Standard unit	kg	1349	1397	1397	1521	1556	1995	2049	2211	
Unit + option 15LS <sup>(3)</sup>	kg	1432	1480	1480	1630	1665	2122	2176	2356	
Unit + option 15LS + option 116W <sup>(3)</sup>	kg	1567	1615	1615	1765	1811	2271	2371	2551	
Unit + option 15LS + option 116W + option 307 <sup>(3)</sup>	kg	2550	2598	2598	2748	2794	3258	3357	3537	

\* In accordance with EN14511-3:2022.  
 \*\* In accordance with EN14825:2022, average climate conditions  
 CA1 Cooling mode conditions: evaporator water inlet/outlet temperature 12 °C/7 °C, outdoor air temperature 35 °C, evaporator fouling factor 0 m<sup>2</sup>. k/W  
 $\eta_s$  cool<sub>12/7°C</sub> & SEER<sub>12/7°C</sub> **Values in bold comply with the applicable Ecodesign Regulation (EU) No. 2016/2281 for Comfort applications**  
 SEER<sub>23/18°C</sub> **Values in bold comply with the applicable Ecodesign Regulation (EU) No. 2016/2281 for Comfort applications**  
 SEPR<sub>12/7°C</sub> Applicable Ecodesign regulation (UE) No 2016/2281  
 SEPR<sub>-2/-8°C</sub> **Applicable Ecodesign regulation (UE) No 2015/1095**  
 IPLV.IP Calculated as per AHRI standard 550-590  
 IPLV.SI Calculated as per AHRI standard 551-591.  
 (1) In dB ref=10<sup>-12</sup> W, (A) weighting. Declared dual-number noise emission value in accordance with ISO 4871 with an uncertainty of +/-3 dB(A). Measured in accordance with ISO 9614-1 and certified by Eurovent.  
 (2) In dB ref 20 µPa, (A) weighting. Declared dual-number noise emission value in accordance with ISO 4871 with an uncertainty of +/-3 dB(A). For information, calculated from the sound power Lw(A).  
 (3) Options: 15LS = Very low noise level, 116W = Variable-speed high pressure dual-pump hydraulic module, 307 = Water buffer tank module  
 (4) Values are guidelines only. Refer to the unit name plate.



Eurovent certified values

PRESENTATION  
COOLING  
HEATING  
AIR TREATMENT  
CONTROLS

## PHYSICAL DATA, SIZES 170R TO 380R

30RB		170R	190R	210R	230R	270R	310R	340R	380R
<b>Compressors</b>		Hermetic Scroll 48,3 r/s							
Circuit A		1	1	1	2	2	2	2	3
Circuit B		2	2	2	2	2	3	3	3
Number of power stages		3	3	3	4	4	5	5	6
<b>Unit PED category</b>		III	III	III	III	III	III	III	III
<b>Refrigerant<sup>(4)</sup></b>		R32 / A2L /GWP= 675 as per AR4							
Circuit A	kg	6,3	9,4	9,4	11,1	11,5	12,2	13,0	17,7
	tCO <sub>2</sub> e	4,2	6,3	6,3	7,5	7,8	8,2	8,8	11,9
Circuit B	kg	11,1	11,1	11,1	11,1	11,5	17,1	17,9	18,5
	tCO <sub>2</sub> e	7,5	7,5	7,5	7,5	7,8	11,5	12,0	12,5
<b>Oil</b>									
Circuit A	l	6,60	6,60	6,60	13,20	13,20	13,20	13,20	19,80
Circuit B	l	13,20	13,20	13,20	13,20	13,20	19,80	19,80	19,80
<b>Capacity control</b>		SmartVu™							
Minimum capacity	%	33	33	33	25	25	20	20	17
<b>Condenser</b>		All-aluminium micro-channel coils (MCHE)							
<b>Fans</b>		Axial Flying Bird 6 with rotating impeller							
<b>Standard unit</b>									
Quantity		3	4	4	4	4	5	5	6
Maximum total air flow	l/s	14460	19280	19280	19280	19280	24100	24100	28920
Maximum rotation speed	r/s	16	16	16	16	16	16	16	16
<b>Evaporator</b>		Direct expansion brazed-plate heat exchanger							
Water volume	l	15	15	15	19	27	27	35	44
Max. water-side operating pressure without hydraulic module	kPa	1000	1000	1000	1000	1000	1000	1000	1000
<b>Hydraulic module (option)</b>		Pump, Victaulic screen filter, relief valve, water and air vent valve, pressure sensors							
Pump		Centrifugal pump, monocell, 48,3 r/s, low or high pressure (as required), single or dual (as required)							
Expansion tank volume (option)	l	50	50	50	50	80	80	80	80
Buffer tank volume (option)	l	550	550	550	550	550	550	550	550
Max. water-side operating pressure with hydraulic module	kPa	400	400	400	400	400	400	400	400
<b>Water connections with or without hydraulic module</b>		Victaulic® type							
Connections	inches	3	3	3	3	3	4	4	4
External diameter	mm	88,9	88,9	88,9	88,9	88,9	114,3	114,3	114,3
<b>Casing paintwork</b>		Colour code RAL 7035							

(4) Values are guidelines only. Refer to the unit name plate.

PHYSICAL DATA, SIZES 410R TO 950R

30RB		410R	450R	480R	550R	610R	670R	720R	770R	800R	870R	950R	
<b>Cooling</b>													
<b>Standard unit</b>	Nominal capacity	kW	416	451	484	553	616	677	726	782	807	882	943
	Full load performances*	EER	kW/kW	3,10	3,15	3,09	3,08	3,16	3,14	3,06	3,07	3,04	3,00
Seasonal energy efficiency**	<b>SEER<sub>12/7°C</sub> Comfort low temp.</b>	<b>kWh/kWh</b>	<b>4,61</b>	<b>4,72</b>	<b>4,72</b>	<b>4,72</b>	<b>4,77</b>	<b>4,85</b>	<b>4,80</b>	<b>4,84</b>	<b>4,83</b>	<b>4,79</b>	<b>4,72</b>
	<b>ηs cool<sub>12/7°C</sub></b>	<b>%</b>	<b>182</b>	<b>186</b>	<b>186</b>	<b>186</b>	<b>188</b>	<b>191</b>	<b>189</b>	<b>191</b>	<b>190</b>	<b>189</b>	<b>186</b>
	<b>SEER<sub>23/18°C</sub> Comfort medium temp.</b>	<b>kWh/kWh</b>	<b>5,58</b>	<b>5,77</b>	<b>5,72</b>	<b>5,72</b>	<b>6,01</b>	<b>6,01</b>	<b>5,87</b>	<b>5,99</b>	<b>5,95</b>	<b>5,96</b>	<b>5,79</b>
	SEPR <sub>23/18°C</sub> Process high temp.	kWh/kWh	5,43	5,47	5,46	5,43	5,41	5,44	5,34	5,39	5,35	5,28	5,17
	<b>SEPR<sub>-2/-8°C</sub> Process medium temp.</b>	<b>kWh/kWh</b>	<b>3,08</b>	<b>3,05</b>	<b>3,07</b>	<b>3,06</b>	<b>3,45</b>	<b>3,38</b>	<b>3,42</b>	<b>3,36</b>	<b>3,38</b>	<b>3,33</b>	<b>3,36</b>
Part Load integrated values	IPLV.IP	Btu/Wh	16,97	17,11	17,10	17,10	17,47	17,41	17,22	17,39	17,34	17,24	17,03
Part Load integrated values	IPLV.SI	kW/kW	4,931	4,977	4,973	4,966	5,070	5,061	5,016	5,062	5,049	5,021	4,962
<b>Unit + option 15LS</b>	Nominal capacity	kW	394	428	458	523	586	645	688	743	765	836	889
	Full load performances*	EER	kW/kW	2,86	2,94	2,85	2,85	2,94	2,94	2,83	2,85	2,81	2,77
Seasonal energy efficiency**	<b>SEER<sub>12/7°C</sub> Comfort low temp.</b>	<b>kWh/kWh</b>	<b>4,89</b>	<b>5,08</b>	<b>5,03</b>	<b>4,95</b>	<b>5,08</b>	<b>5,16</b>	<b>5,05</b>	<b>5,17</b>	<b>5,13</b>	<b>4,98</b>	<b>4,86</b>
	<b>ηs cool<sub>12/7°C</sub></b>	<b>%</b>	<b>193</b>	<b>200</b>	<b>198</b>	<b>195</b>	<b>200</b>	<b>204</b>	<b>199</b>	<b>204</b>	<b>202</b>	<b>196</b>	<b>191</b>
	<b>SEER<sub>23/18°C</sub> Comfort medium temp.</b>	<b>kWh/kWh</b>	<b>5,80</b>	<b>5,99</b>	<b>5,91</b>	<b>5,98</b>	<b>6,26</b>	<b>6,44</b>	<b>6,20</b>	<b>6,43</b>	<b>6,34</b>	<b>6,10</b>	<b>5,85</b>
	SEPR <sub>23/18°C</sub> Process high temp.	kWh/kWh	5,63	5,58	5,58	5,54	5,52	5,58	5,44	5,46	5,41	5,36	5,22
	<b>SEPR<sub>-2/-8°C</sub> Process medium temp.</b>	<b>kWh/kWh</b>	<b>3,16</b>	<b>3,13</b>	<b>3,15</b>	<b>3,15</b>	<b>3,54</b>	<b>3,46</b>	<b>3,49</b>	<b>3,44</b>	<b>3,46</b>	<b>3,41</b>	<b>3,44</b>
<b>Sound levels</b>													
<b>Standard unit</b>													
Sound power <sup>(1)</sup>		dB(A)	93,5	94,0	94,0	94,5	97,5	97,5	98,0	98,0	98,5	98,5	99,0
Sound pressure at 10 m <sup>(2)</sup>		dB(A)	61,5	61,5	61,5	62,0	65,0	65,0	66,0	65,0	66,0	66,0	66,5
<b>Unit + option 15LS<sup>(3)</sup></b>													
Sound power <sup>(1)</sup>		dB(A)	88,0	88,5	88,5	89,0	92,5	92,5	93,0	93,0	93,5	93,5	94,5
Sound pressure at 10 m <sup>(2)</sup>		dB(A)	56,0	56,0	56,5	57,0	60,5	60,0	60,5	60,0	61,0	60,5	61,5
<b>Dimensions - standard unit</b>													
<b>Standard unit</b>													
Length		mm	3604	4798	4798	4798	5992	5992	5992	7186	7186	7186	7186
Width		mm	2253	2253	2253	2253	2253	2253	2253	2253	2253	2253	2253
Height		mm	2324	2324	2324	2324	2324	2324	2324	2324	2324	2324	2324
<b>Unit + option 307<sup>(3)</sup></b>													
Length		mm	4798	5992	5992	5992	7186	7186	7186	8380	8380	8380	8380
<b>Operating weight<sup>(4)</sup></b>													
Standard unit		kg	2269	2697	2722	2927	3265	3511	3511	4042	4042	4291	4291
Unit + option 15LS <sup>(3)</sup>		kg	2414	2860	2885	3108	3398	3664	3664	4216	4216	4485	4485
Unit + option 15LS + option 116W <sup>(3)</sup>		kg	2609	3094	3119	3379	3708	3974	3974	4605	4605	4874	4874
Unit + option 15LS + option 116W + option 307 <sup>(3)</sup>		kg	3594	4086	4111	4371	4715	4981	4981	5626	5626	5895	5895

\* In accordance with EN14511-3:2022.  
 \*\* In accordance with EN14825:2022, average climate conditions  
 CA1 Cooling mode conditions: evaporator water inlet/outlet temperature 12 °C/7 °C, outdoor air temperature 35 °C, evaporator fouling factor 0 m<sup>2</sup>. kW/W  
**Values in bold comply with the applicable Ecodesign Regulation (EU) No. 2016/2281 for Comfort applications**  
**Values in bold comply with the applicable Ecodesign Regulation (EU) No. 2016/2281 for Comfort applications**  
 Applicable Ecodesign regulation (UE) No 2016/2281  
**Applicable Ecodesign regulation (UE) No 2015/1095**  
 IPLV.IP Calculated as per AHRI standard 550-590  
 IPLV.SI Calculated as per AHRI standard 551-591.  
 (1) In dB ref=10<sup>-12</sup> W, (A) weighting. Declared dual-number noise emission value in accordance with ISO 4871 with an uncertainty of +/-3 dB(A). Measured in accordance with ISO 9614-1 and certified by Eurovent.  
 (2) In dB ref 20 µPa, (A) weighting. Declared dual-number noise emission value in accordance with ISO 4871 with an uncertainty of +/-3 dB(A). For information, calculated from the sound power Lw(A).  
 (3) Options: 15LS = Very low noise level, 116W = Variable-speed high pressure dual-pump hydraulic module, 307 = Water buffer tank module  
 (4) Values are guidelines only. Refer to the unit name plate.



Eurovent certified values



## PHYSICAL DATA, SIZES 410R TO 950R

30RB		410R	450R	480R	550R	610R	670R	720R	770R	800R	870R	950R
<b>Compressors</b>		Hermetic Scroll 48,3 r/s										
Circuit A		3	3	3	4	2	3	3	3	3	4	4
Circuit B		3	4	4	4	3	3	3	4	4	4	4
Number of power stages		6	7	7	8	5	6	6	7	7	8	8
<b>Unit PED category</b>		III	IV	IV	IV	III	III	III	IV	IV	IV	IV
<b>Refrigerant<sup>(4)</sup></b>		R32 / A2L /GWP= 675 as per AR4										
Circuit A	kg	18,5	18,8	19,1	24,4	23,0	24,5	24,5	27,3	27,3	30,4	30,4
	tCO <sub>2</sub> e	12,5	12,7	12,9	16,5	15,5	16,5	16,5	18,4	18,4	20,5	20,5
Circuit B	kg	19,3	24,5	24,9	25,4	24,5	24,5	24,5	30,4	30,4	30,4	30,4
	tCO <sub>2</sub> e	13,0	16,5	16,8	17,1	16,5	16,5	16,5	20,5	20,5	20,5	20,5
<b>Oil</b>												
Circuit A	l	19,8	19,8	19,8	26,4	13,2	19,8	19,8	19,8	19,8	26,4	26,4
Circuit B	l	19,8	26,4	26,4	26,4	19,8	19,8	19,8	26,4	26,4	26,4	26,4
<b>Capacity control</b>		SmartVu™										
Minimum capacity	%	17	14	14	13	20	17	17	14	14	13	13
<b>Condenser</b>		All-aluminium micro-channel coils (MCHE)										
<b>Fans</b>		Axial Flying Bird 6 with rotating impeller										
<b>Standard unit</b>												
Quantity		6	7	7	8	9	10	10	11	11	12	12
Maximum total air flow	l/s	28920	33740	33740	38560	43380	48200	48200	53020	53020	57840	57840
Maximum rotation speed	r/s	16	16	16	16	16	16	16	16	16	16	16
<b>Evaporator</b>		Direct expansion brazed-plate heat exchanger										
Water volume	l	44	44	47	53	73	73	73	84	84	84	84
Max. water-side operating pressure without hydraulic module	kPa	1000	1000	1000	1000	1000	1000	1000	1000	1000	1000	1000
<b>Hydraulic module (option)</b>		Pump, Victaulic screen filter, relief valve, water and air vent valve, pressure sensors										
Pump		Centrifugal pump, monocell, 48,3 r/s, low or high pressure (as required), single or dual (as required)										
Expansion tank volume (option)	l	80	80	80	80	80	80	80	80	80	80	80
Buffer tank volume (option)	l	550	550	550	550	550	550	550	550	550	550	550
Max. water-side operating pressure with hydraulic module	kPa	400	400	400	400	400	400	400	400	400	400	400
<b>Water connections with or without hydraulic module</b>		Victaulic® type										
Connections	inches	4	4	4	4	5	5	5	5	5	5	5
External diameter	mm	114,3	114,3	114,3	114,3	139,7	139,7	139,7	139,7	139,7	139,7	139,7
<b>Casing paintwork</b>		Colour code RAL 7035										

(4) Values are guidelines only. Refer to the unit name plate.

PHYSICAL PROPERTIES, SIZES 170R TO 410R

30RBP	170R	190R	210R	230R	270R	310R	340R	380R	410R
-------	------	------	------	------	------	------	------	------	------

Cooling

<b>Standard unit</b>	Nominal capacity	kW	172	187	206	227	270	311	346	380	416
	Full load performances* CA1	EER	kW/kW	3,20	3,36	3,21	3,16	3,03	3,15	3,09	3,14
Seasonal energy efficiency**	<b>SEER<sub>12/7°C</sub> Comfort low temp.</b>	<b>kWh/kWh</b>	<b>4,82</b>	<b>5,02</b>	<b>4,84</b>	<b>4,94</b>	<b>4,79</b>	<b>5,25</b>	<b>5,15</b>	<b>5,09</b>	<b>5,11</b>
	$\eta_s$ cool <sub>12/7°C</sub>	%	190	198	191	195	189	207	203	201	201
	<b>SEER<sub>23/18°C</sub> Comfort medium temp.</b>	<b>kWh/kWh</b>	<b>5,98</b>	<b>6,23</b>	<b>5,93</b>	<b>5,99</b>	<b>5,69</b>	<b>6,35</b>	<b>6,17</b>	<b>6,13</b>	<b>6,07</b>
	SEPR <sub>12/7°C</sub> Process high temp.	kWh/kWh	6,30	6,61	6,42	6,13	5,97	6,30	6,24	6,36	6,30
	<b>SEPR<sub>-2/-8°C</sub> Process medium temp.</b>	<b>kWh/kWh</b>	<b>3,48</b>	<b>3,60</b>	<b>3,54</b>	<b>3,41</b>	<b>3,41</b>	<b>3,51</b>	<b>3,56</b>	<b>3,50</b>	<b>3,57</b>
Part Load integrated values	IPLV.IP	Btu/Wh	18,42	19,72	18,25	18,94	18,49	19,31	19,18	18,97	18,87
Part Load integrated values	IPLV.SI	kW/kW	5,37	5,73	5,31	5,51	5,37	5,61	5,56	5,50	5,47
<b>Unit + option 15LS</b>	Nominal capacity	kW	165	180	198	217	256	296	328	361	394
	Full load performances* CA1	EER	kW/kW	3,05	3,24	3,04	3,02	2,81	2,96	2,85	2,94
Seasonal energy efficiency**	<b>SEER<sub>12/7°C</sub> Comfort low temp.</b>	<b>kWh/kWh</b>	<b>4,80</b>	<b>5,00</b>	<b>4,81</b>	<b>4,90</b>	<b>4,73</b>	<b>5,20</b>	<b>5,08</b>	<b>5,11</b>	<b>5,09</b>
	$\eta_s$ cool <sub>12/7°C</sub>	%	189	197	189	193	186	205	200	201	201
	<b>SEER<sub>23/18°C</sub> Comfort medium temp.</b>	<b>kWh/kWh</b>	<b>5,95</b>	<b>6,18</b>	<b>5,83</b>	<b>5,98</b>	<b>5,58</b>	<b>6,36</b>	<b>6,13</b>	<b>6,03</b>	<b>5,95</b>
	SEPR <sub>12/7°C</sub> Process high temp.	kWh/kWh	6,24	6,66	6,49	6,12	5,88	6,34	6,25	6,42	6,34
	<b>SEPR<sub>-2/-8°C</sub> Process medium temp.</b>	<b>kWh/kWh</b>	<b>3,37</b>	<b>3,45</b>	<b>3,39</b>	<b>3,28</b>	<b>3,28</b>	<b>3,39</b>	<b>3,43</b>	<b>3,39</b>	<b>3,44</b>

Sound levels

<b>Standard unit</b>											
Sound power <sup>(1)</sup>	dB(A)	91,0	90,5	90,5	92,0	92,0	93,0	93,0	93,5	93,5	
Sound pressure at 10 m <sup>(2)</sup>	dB(A)	58,5	58,5	58,5	60,0	60,0	60,5	60,5	61,0	61,5	
<b>Unit + option 15LS<sup>(3)</sup></b>											
Sound power <sup>(1)</sup>	dB(A)	85,5	85,5	85,5	86,5	86,5	87,5	87,5	88,0	88,0	
Sound pressure at 10 m <sup>(2)</sup>	dB(A)	53,0	53,5	53,5	54,5	54,5	55,5	55,5	55,5	56,0	

Dimensions - standard unit

<b>Standard unit</b>											
Length	mm	2410	2410	2410	2410	2410	3604	3604	3604	3604	
Width	mm	2253	2253	2253	2253	2253	2253	2253	2253	2253	
Height	mm	2324	2324	2324	2324	2324	2324	2324	2324	2324	

Unit + option 307<sup>(3)</sup>

Length	mm	3604	3604	3604	3604	3604	4798	4798	4798	4798
--------	----	------	------	------	------	------	------	------	------	------

Operating weight<sup>(4)</sup>

Standard unit	kg	1349	1397	1397	1521	1556	1995	2049	2211	2269
Unit + option 15LS <sup>(3)</sup>	kg	1432	1480	1480	1630	1665	2122	2176	2356	2414
Unit + option 15LS + option 116W <sup>(3)</sup>	kg	1567	1615	1615	1765	1811	2271	2371	2551	2609
Unit + option 15LS + option 116W + option 307 <sup>(3)</sup>	kg	2550	2598	2598	2748	2794	3258	3357	3537	3594

\* In accordance with EN14511-3:2022.  
 \*\* In accordance with EN14825:2022, average climate conditions  
 CA1 Cooling mode conditions: evaporator water inlet/outlet temperature 12 °C/7 °C, outdoor air temperature 35 °C, evaporator fouling factor 0 m<sup>2</sup>, k/W  
 $\eta_s$  cool<sub>12/7°C</sub> & SEER<sub>12/7°C</sub> Values in bold comply with Ecodesign Regulation (EU) No. 2016/2281 for Comfort applications  
 SEER<sub>23/18°C</sub> Values in bold comply with Ecodesign Regulation (EU) No. 2016/2281 for Comfort applications  
 SEPR<sub>12/7°C</sub> Values calculated in accordance with EN 14825:2022  
 SEPR<sub>-2/-8°C</sub> Values calculated in accordance with EN 14825:2022  
 IPLV.IP Calculated as per AHRI standard 550-590  
 IPLV.SI Calculated as per AHRI standard 551-591.  
 (1) In dB ref=10<sup>-12</sup> W, (A) weighting. Declared dual-number noise emission value in accordance with ISO 4871 with an uncertainty of +/-3 dB(A). Measured in accordance with ISO 9614-1 and certified by Eurovent.  
 (2) In dB ref 20 µPa, (A) weighting. Declared dual-number noise emission value in accordance with ISO 4871 with an uncertainty of +/-3 dB(A). For information, calculated from the sound power Lw(A).  
 (3) Options: 15LS = Very low noise level, 116W = Variable-speed high pressure dual-pump hydraulic module, 307 = Water buffer tank module  
 (4) Values are guidelines only. Refer to the unit name plate.



Eurovent certified values

## PHYSICAL PROPERTIES, SIZES 170R TO 410R

30RBP		170R	190R	210R	230R	270R	310R	340R	380R	410R
<b>Compressors</b>		Hermetic Scroll 48,3 r/s								
Circuit A		1	1	1	2	2	2	2	3	3
Circuit B		2	2	2	2	2	3	3	3	3
Number of power stages		3	3	3	4	4	5	5	6	6
<b>Unit PED category</b>		III	III	III	III	III	III	III	III	III
<b>Refrigerant<sup>(4)</sup></b>		R32 / A2L /GWP= 675 as per AR4								
Circuit A	kg	6,3	9,4	9,4	11,1	11,5	12,2	13,0	17,7	18,5
	tCO <sub>2</sub> e	4,2	6,3	6,3	7,5	7,8	8,2	8,8	11,9	12,5
Circuit B	kg	11,1	11,1	11,1	11,1	11,5	17,1	17,9	18,5	19,3
	tCO <sub>2</sub> e	7,5	7,5	7,5	7,5	7,8	11,5	12,0	12,5	13,0
<b>Oil</b>										
Circuit A	l	6,6	6,6	6,60	13,2	13,2	13,2	13,2	19,8	19,8
Circuit B	l	13,2	13,2	13,2	13,2	13,2	19,8	19,8	19,8	19,8
<b>Capacity control</b>		SmartVu™								
Minimum capacity	%	33	33	33	25	25	20	20	17	17
<b>Condenser</b>		All-aluminium micro-channel coils (MCHE)								
<b>Fans</b>		Axial Flying Bird 6 with rotating impeller								
<b>Standard unit</b>										
Quantity		3	4	4	4	4	5	5	6	6
Maximum total air flow	l/s	14460	19280	19280	19280	19280	24100	24100	28920	28920
Maximum rotation speed	r/s	16	16	16	16	16	16	16	16	16
<b>Evaporator</b>		Direct expansion brazed-plate heat exchanger								
Water volume	l	15	15	15	19	27	27	35	44	44
Max. water-side operating pressure without hydraulic module	kPa	1000	1000	1000	1000	1000	1000	1000	1000	1000
<b>Hydraulic module (option)</b>		Pump, Victaulic screen filter, relief valve, water and air vent valve, pressure sensors								
Pump		Centrifugal pump, monocoil, 48,3 r/s, low or high pressure (as required), single or dual (as required)								
Expansion tank volume (option)	l	50	50	50	50	50	80	80	80	80
Buffer tank volume (option)	l	550	550	550	550	550	550	550	550	550
Max. water-side operating pressure with hydraulic module	kPa	400	400	400	400	400	400	400	400	400
<b>Water connections with or without hydraulic module</b>		Victaulic® type								
Connections	inches	3	3	3	3	3	4	4	4	4
External diameter	mm	88,9	88,9	88,9	88,9	88,9	114,3	114,3	114,3	114,3
<b>Casing paintwork</b>		Colour code RAL 7035								

(4) Values are guidelines only. Refer to the unit name plate.

PHYSICAL PROPERTIES, SIZES 450R TO 950R

30RBP		450R	480R	550R	610R	670R	720R	770R	800R	870R	950R
<b>Cooling</b>											
<b>Standard unit</b>	Nominal capacity	kW									
	Full load performances* CA1	EER									
Seasonal energy efficiency**	<b>SEER<sub>12/7°C</sub> Comfort low temp.</b>	<b>kWh/kWh</b>									
	<b>ηs cool<sub>12/7°C</sub></b>	<b>%</b>									
	<b>SEER<sub>23/18°C</sub> Comfort medium temp.</b>	<b>kWh/kWh</b>									
	SEPR <sub>12/7°C</sub> Process high temp.	kWh/kWh									
	<b>SEPR<sub>-2/-8°C</sub> Process medium temp.</b>	<b>kWh/kWh</b>									
Part Load integrated values	IPLV.IP	Btu/Wh									
Part Load integrated values	IPLV.SI	kW/kW									
<b>Unit + option 15LS</b>	Nominal capacity	kW									
	Full load performances* CA1	EER									
Seasonal energy efficiency**	<b>SEER<sub>12/7°C</sub> Comfort low temp.</b>	<b>kWh/kWh</b>									
	<b>ηs cool<sub>12/7°C</sub></b>	<b>%</b>									
	<b>SEER<sub>23/18°C</sub> Comfort medium temp.</b>	<b>kWh/kWh</b>									
	SEPR <sub>12/7°C</sub> Process high temp.	kWh/kWh									
	<b>SEPR<sub>-2/-8°C</sub> Process medium temp.</b>	<b>kWh/kWh</b>									
<b>Sound levels</b>											
<b>Standard unit</b>											
	Sound power <sup>(1)</sup>	dB(A)									
	Sound pressure at 10 m <sup>(2)</sup>	dB(A)									
<b>Unit + option 15LS<sup>(3)</sup></b>											
	Sound power <sup>(1)</sup>	dB(A)									
	Sound pressure at 10 m <sup>(2)</sup>	dB(A)									
<b>Dimensions - standard unit</b>											
<b>Standard unit</b>											
	Length	mm									
	Width	mm									
	Height	mm									
<b>Unit + option 307<sup>(3)</sup></b>											
	Length	mm									
<b>Operating weight<sup>(4)</sup></b>											
	Standard unit	kg									
	Unit + option 15LS <sup>(3)</sup>	kg									
	Unit + option 15LS + option 116W <sup>(3)</sup>	kg									
	Unit + option 15LS + option 116W + option 307 <sup>(3)</sup>	kg									

\* In accordance with EN14511-3:2022.  
 \*\* In accordance with EN14825:2022, average climate conditions  
 CA1 Cooling mode conditions: evaporator water inlet/outlet temperature 12 °C/7 °C, outdoor air temperature 35 °C, evaporator fouling factor 0 m<sup>2</sup>, k/W  
**ηs cool<sub>12/7°C</sub> & SEER<sub>12/7°C</sub>** Values in bold comply with Ecodesign Regulation (EU) No. 2016/2281 for Comfort applications  
**SEER<sub>23/18°C</sub>** Values in bold comply with Ecodesign Regulation (EU) No. 2016/2281 for Comfort applications  
**SEPR<sub>12/7°C</sub>** Values calculated in accordance with EN 14825:2022  
**SEPR<sub>-2/-8°C</sub>** Values calculated in accordance with EN 14825:2022  
 IPLV.IP Calculated as per AHRI standard 550-590  
 IPLV.SI Calculated as per AHRI standard 551-591.  
 (1) In dB ref=10<sup>-12</sup> W, (A) weighting. Declared dual-number noise emission value in accordance with ISO 4871 with an uncertainty of +/-3 dB(A). Measured in accordance with ISO 9614-1 and certified by Eurovent.  
 (2) In dB ref 20 µPa, (A) weighting. Declared dual-number noise emission value in accordance with ISO 4871 with an uncertainty of +/-3 dB(A). For information, calculated from the sound power Lw(A).  
 (3) Options: 15LS = Very low noise level, 116W = Variable-speed high pressure dual-pump hydraulic module, 307 = Water buffer tank module  
 (4) Values are guidelines only. Refer to the unit name plate.



Eurovent certified values

## PHYSICAL PROPERTIES, SIZES 450R TO 950R

30RBP		450R	480R	550R	610R	670R	720R	770R	800R	870R	950R
<b>Compressors</b>		Hermetic Scroll 48,3 r/s									
Circuit A		3	3	4	2	3	3	3	3	4	4
Circuit B		4	4	4	3	3	3	4	4	4	4
Number of power stages		7	7	8	5	6	6	7	7	8	8
<b>Unit PED category</b>		IV	IV	IV	III	III	III	IV	IV	IV	IV
<b>Refrigerant<sup>(4)</sup></b>		R32 / A2L /GWP= 675 as per AR4									
Circuit A	kg	18,8	19,1	24,4	23,0	24,5	24,5	27,3	27,3	30,4	30,4
	tCO <sub>2</sub> e	12,7	12,9	16,5	15,5	16,5	16,5	18,4	18,4	20,5	20,5
Circuit B	kg	24,5	24,9	25,4	24,5	24,5	24,5	30,4	30,4	30,4	30,4
	tCO <sub>2</sub> e	16,5	16,8	17,1	16,5	16,5	16,5	20,5	20,5	20,5	20,5
<b>Oil</b>											
Circuit A	l	19,8	19,8	26,4	13,2	19,8	19,8	19,8	19,8	26,4	26,4
Circuit B	l	26,4	26,4	26,4	19,8	19,8	19,8	26,4	26,4	26,4	26,4
<b>Capacity control</b>		SmartVu™									
Minimum capacity	%	14	14	13	20	17	17	14	14	13	13
<b>Condenser</b>		All-aluminium micro-channel coils (MCHE)									
<b>Fans</b>		Axial Flying Bird 6 with rotating impeller									
<b>Standard unit</b>											
Quantity		7	7	8	9	10	10	11	11	12	12
Maximum total air flow	l/s	33740	33740	38560	43380	48200	48200	53020	53020	57840	57840
Maximum rotation speed	r/s	16	16	16	16	16	16	16	16	16	16
<b>Evaporator</b>		Direct expansion brazed-plate heat exchanger									
Water volume	l	44	47	53	73	73	73	84	84	84	84
Max. water-side operating pressure without hydraulic module	kPa	1000	1000	1000	1000	1000	1000	1000	1000	1000	1000
<b>Hydraulic module (option)</b>		Pump, Victaulic screen filter, relief valve, water and air vent valve, pressure sensors									
Pump		Centrifugal pump, monocell, 48,3 r/s, low or high pressure (as required), single or dual (as required)									
Expansion tank volume (option)	l	80	80	80	80	80	80	80	80	80	80
Buffer tank volume (option)	l	550	550	550	550	550	550	550	550	550	550
Max. water-side operating pressure with hydraulic module	kPa	400	400	400	400	400	400	400	400	400	400
<b>Water connections with or without hydraulic module</b>		Victaulic® type									
Connections	inches	4	4	4	5	5	5	5	5	5	5
External diameter	mm	114,3	114,3	114,3	139,7	139,7	139,7	139,7	139,7	139,7	139,7
<b>Casing paintwork</b>		Colour code RAL 7035									

(4) Values are guidelines only. Refer to the unit name plate.



PHYSICAL DATA, SIZES 165R TO 520R

30RQ			165R	180R	210R	230R	270R	310R	330R	370R	400R	430R	470R	520R	
<b>Heating</b>															
<b>Standard unit Full load performances*</b>	HA1	Nominal capacity	kW	178	197	237	256	275	317	336	387	406	441	467	537
		COP	kW/kW	3,88	3,80	3,84	3,84	3,82	3,82	3,81	3,82	3,81	3,80	3,73	3,80
	HA2	Nominal capacity	kW	173	192	231	250	269	310	329	378	397	431	458	526
		COP	kW/kW	3,16	3,09	3,14	3,12	3,11	3,10	3,09	3,10	3,09	3,10	3,03	3,09
Seasonal energy efficiency**	HA1	<b>SCOP</b> <sub>30/35°C</sub>	<b>kWh/kWh</b>	<b>3,44</b>	<b>3,45</b>	<b>3,39</b>	<b>3,47</b>	<b>3,48</b>	<b>3,57</b>	<b>3,58</b>	<b>3,55</b>	<b>3,57</b>	<b>3,54</b>	<b>3,53</b>	<b>3,57</b>
		<b>ηs heat</b> <sub>30/35°C</sub>	<b>%</b>	<b>135</b>	<b>135</b>	<b>133</b>	<b>136</b>	<b>136</b>	<b>140</b>	<b>140</b>	<b>139</b>	<b>140</b>	<b>139</b>	<b>138</b>	<b>140</b>
		P <sub>rated</sub>	kW	139	155	186	200	217	250	266	305	321	349	371	400
<b>Cooling</b>															
<b>Standard unit Full load performances*</b>	CA1	Nominal capacity	kW	164	181	215	236	254	302	324	362	381	413	439	500
		EER	kW/kW	2,87	2,73	2,86	2,81	2,76	2,85	2,80	2,82	2,76	2,82	2,74	2,74
Seasonal energy efficiency**		SEER <sub>12/7°C</sub> Comfort low temp.	kWh/kWh	3,91	3,81	3,88	3,88	3,84	4,15	4,21	4,14	4,07	4,04	4,03	4,05
		SEPR <sub>12/7°C</sub> Process high temp.	kWh/kWh	4,62	4,47	4,54	4,48	4,46	4,69	4,64	4,77	4,70	4,76	4,66	4,70
<b>Unit + option 15LS Full load performances*</b>	CA1	Nominal capacity	kW	155	171	204	223	239	285	305	341	358	389	414	470
		EER	kW/kW	2,73	2,55	2,73	2,63	2,56	2,66	2,59	2,64	2,57	2,64	2,55	2,55
Seasonal energy efficiency**		SEER <sub>12/7°C</sub> Comfort low temp.	kWh/kWh	4,17	4,01	4,18	4,08	4,04	4,48	4,50	4,46	4,33	4,44	4,38	4,32
		SEPR <sub>12/7°C</sub> Process high temp.	kWh/kWh	4,68	4,51	4,64	4,52	4,50	4,83	4,76	4,93	4,79	4,94	4,82	4,83
<b>Sound levels</b>															
<b>Standard unit</b>															
		Sound power <sup>(1)</sup>	dB(A)	90,5	91,0	91,5	92,0	92,0	93,0	93,5	94,0	94,0	94,5	94,5	95,0
		Sound pressure at 10 m <sup>(2)</sup>	dB(A)	58,0	58,5	59,5	60,0	60,0	60,5	61,0	61,5	61,5	62,0	62,0	62,5
<b>Unit + option 15LS<sup>(3)</sup></b>															
		Sound power <sup>(1)</sup>	dB(A)	85,0	86,0	86,5	87,0	87,0	88,0	88,0	89,0	89,0	89,5	90,0	90,0
		Sound pressure at 10 m <sup>(2)</sup>	dB(A)	53,0	53,5	54,0	54,5	54,5	55,5	55,5	56,5	56,5	57,0	57,5	57,5
<b>Dimensions - standard unit</b>															
<b>Standard unit</b>															
		Length	mm	2410	2410	2410	2410	2410	3604	3604	3604	3604	4798	4798	4798
		Width	mm	2253	2253	2253	2253	2253	2253	2253	2253	2253	2253	2253	2253
		Height	mm	2324	2324	2324	2324	2324	2324	2324	2324	2324	2324	2324	2324
<b>Unit + option 307<sup>(3)</sup></b>															
		Length	mm	3604	3604	3604	3604	3604	4798	4798	4798	4798	5992	5992	5992
<b>Operating weight<sup>(4)</sup></b>															
		Standard unit	kg	1569	1575	1784	1811	1817	2394	2452	2672	2678	3154	3180	3430
		Unit + option 15LS <sup>(3)</sup>	kg	1652	1658	1892	1920	1926	2520	2579	2817	2823	3317	3343	3611
		Unit + option 15LS + option 116W <sup>(3)</sup>	kg	1787	1793	2039	2067	2073	2715	2774	3051	3057	3551	3614	3882
		Unit + option 15LS + option 116W + option 307 <sup>(3)</sup>	kg	2771	2777	3022	3049	3055	3725	3783	4060	4066	4551	4614	4882

\* In accordance with EN14511-3:2022.  
 \*\* In accordance with EN14825:2022, average climate conditions  
 HA1 Heating mode conditions: Water type heat exchanger water inlet/outlet temperature 30 °C/35 °C, outside air temperature tdb/twb = 7 °C db/6 °C wb, evaporator fouling factor 0 m<sup>2</sup>. k/W  
 HA2 Heating mode conditions: Water type heat exchanger water inlet/outlet temperature 40 °C/45 °C, outside air temperature tdb/twb = 7 °C db/6 °C wb, evaporator fouling factor 0 m<sup>2</sup>. k/W  
 CA1 Cooling mode conditions: evaporator water inlet/outlet temperature 12 °C/7 °C, outdoor air temperature 35 °C, evaporator fouling factor 0 m<sup>2</sup>. k/W  
**ηs heat<sub>30/35°C</sub> & SCOP<sub>30/35°C</sub>** Values in bold comply with Ecodesign Regulation (EU) No. 813/2013 for Heating applications  
**SEER<sub>12/7°C</sub> & SEPR<sub>12/7°C</sub>** Applicable Ecodesign regulation (EU) No. 2016/2281.  
 (1) In dB ref=10<sup>-12</sup> W, (A) weighting. Declared dual-number noise emission value in accordance with ISO 4871 with an uncertainty of +/-3 dB(A). Measured in accordance with ISO 9614-1 and certified by Eurovent. Cooling mode.  
 (2) In dB ref 20 μPa, (A) weighting. Declared dual-number noise emission value in accordance with ISO 4871 with an uncertainty of +/-3 dB(A). For information, calculated from the sound power Lw(A).  
 (3) Options: 15LS = Very low noise level, 116W = Variable-speed high pressure dual-pump hydraulic module, 307 = Water buffer tank module.  
 (4) Values are guidelines only. Refer to the unit name plate.



Eurovent certified values

## PHYSICAL DATA, SIZES 165R TO 520R

30RQ		165R	180R	210R	230R	270R	310R	330R	370R	400R	430R	470R	520R	
<b>Compressors</b>		Hermetic Scroll 48,3 r/s												
Circuit A/C		1	1	2	2	2	2	2	2	2	3	3	4	
Circuit B/D		2	2	2	2	2	3	3	4	4	4	4	4	
Number of power stages		3	3	4	4	4	5	5	6	6	7	7	8	
<b>Unit PED category</b>		III	III	III	III	III	III	IV	IV	IV	IV	IV	IV	
<b>Refrigerant<sup>(4)</sup></b>		R32 / A2L /GWP= 675 as per AR4												
Circuit A/C		kg	10,5	10,5	16,0	16,0	16,0	16,0	18,0	18,0	18,0	29,0	29,0	35,0
		tCO <sub>2</sub> e	7,1	7,1	10,8	10,8	10,8	10,8	12,2	12,2	12,2	19,6	19,6	23,6
Circuit B/D		kg	16,0	16,0	16,0	16,0	16,0	28,5	28,5	34,0	34,0	34,5	35,0	35,0
		tCO <sub>2</sub> e	10,8	10,8	10,8	10,8	10,8	19,2	19,2	23,0	23,0	23,3	23,6	23,6
<b>Oil</b>														
Circuit A/C			6,6	6,6	13,2	13,2	13,2	13,2	13,2	13,2	13,2	22,8	22,8	30,4
Circuit B/D			13,2	13,2	13,2	13,2	13,2	22,8	22,8	30,4	30,4	30,4	30,4	30,4
<b>Capacity control</b>		SmartVu™												
Minimum capacity		%	33	33	25	25	25	20	20	17	17	14	14	13
<b>Condenser</b>		Grooved copper tubes and aluminium fins												
<b>Fans</b>		Axial Flying Bird 6 with rotating impeller												
<b>Standard unit</b>														
Quantity			3	3	4	4	4	5	5	6	6	7	7	8
Maximum total air flow		l/s	14460	14460	19280	19280	19280	24100	24100	28920	28920	33740	33740	38560
Maximum rotation speed		r/s	16	16	16	16	16	16	16	16	16	16	16	16
<b>Evaporator</b>		Direct expansion brazed-plate heat exchanger												
Water volume		l	16,2	16,2	16,2	20,7	20,7	38,7	48,6	48,6	48,6	48,6	52,2	58,5
Max. water-side operating pressure without hydraulic module		kPa	1000	1000	1000	1000	1000	1000	1000	1000	1000	1000	1000	1000
<b>Hydraulic module (option)</b>		Pump, Victaulic screen filter, relief valve, water and air vent valve, pressure sensors												
Pump		Centrifugal pump, monocell, 48,3 r/s, low or high pressure (as required), single or dual (as required)												
Expansion tank volume (option)		l	50	50	50	50	50	80	80	80	80	80	80	80
Buffer tank volume (option)		l	550	550	550	550	550	550	550	550	550	550	550	550
Max. water-side operating pressure with hydraulic module		kPa	400	400	400	400	400	400	400	400	400	400	400	400
<b>Water connections with or without hydraulic module</b>		Victaulic® type												
Connections		inches	3	3	3	3	3	4	4	4	4	4	4	4
External diameter		mm	88,5	88,6	88,7	88,8	88,9	114,3	114,4	114,5	114,6	114,7	114,8	114,9
<b>Casing paintwork</b>		Colour code RAL 7035												

(4) Values are guidelines only. Refer to the unit name plate.

PHYSICAL DATA, SIZES 165R TO 520R

30RQP			165R	180R	210R	230R	270R	310R	330R	370R	400R	430R	470R	520R	
<b>Heating</b>															
Standard unit Full load performances*	HA1	Nominal capacity	kW	178	197	237	256	275	317	336	387	406	441	467	537
		COP	kW/kW	3,88	3,80	3,84	3,84	3,82	3,82	3,81	3,82	3,81	3,80	3,73	3,80
	HA2	Nominal capacity	kW	173	192	231	250	269	310	329	378	397	431	458	526
		COP	kW/kW	3,16	3,09	3,14	3,13	3,11	3,10	3,09	3,10	3,09	3,10	3,03	3,10
Seasonal energy efficiency**	HA1	SCOP <sub>30/35°C</sub>	kWh/kWh	<b>3,67</b>	<b>3,66</b>	<b>3,74</b>	<b>3,77</b>	<b>3,80</b>	<b>3,87</b>	<b>3,86</b>	<b>3,90</b>	<b>3,91</b>	<b>3,92</b>	<b>3,89</b>	<b>3,96</b>
		η <sub>s heat</sub> <sub>30/35°C</sub>	%	<b>144</b>	<b>143</b>	<b>147</b>	<b>148</b>	<b>149</b>	<b>152</b>	<b>151</b>	<b>153</b>	<b>153</b>	<b>154</b>	<b>153</b>	<b>155</b>
		P <sub>rated</sub>	kW	138	155	185	200	216	250	265	305	320	348	370	399

<b>Cooling</b>															
Standard unit Full load performances*	CA1	Nominal capacity	kW	164	181	215	236	254	302	324	362	381	413	439	500
		EER	kW/kW	2,87	2,72	2,86	2,80	2,76	2,85	2,80	2,82	2,76	2,81	2,74	2,73
Seasonal energy efficiency**		SEER <sub>12/7°C</sub> Comfort low temp.	kWh/kWh	4,41	4,23	4,48	4,41	4,34	4,78	4,81	4,88	4,87	4,81	4,75	4,81
		SEPR <sub>12/7°C</sub> Process high temp.	kWh/kWh	5,47	5,23	5,41	5,23	5,15	5,49	5,34	5,60	5,40	5,60	5,43	5,47
Unit + option 15LS Full load performances*	CA1	Nominal capacity	kW	155	171	204	223	239	285	305	341	358	389	414	470
		EER	kW/kW	2,73	2,55	2,69	2,61	2,56	2,66	2,59	2,63	2,56	2,64	2,55	2,54
Seasonal energy efficiency**		SEER <sub>12/7°C</sub> Comfort low temp.	kWh/kWh	4,38	4,23	4,41	4,37	4,35	4,73	4,76	4,91	4,78	4,94	4,86	4,75
		SEPR <sub>12/7°C</sub> Process high temp.	kWh/kWh	5,39	5,17	5,23	5,12	5,10	5,51	5,37	5,62	5,39	5,65	5,47	5,52

<b>Sound levels</b>															
<b>Standard unit</b>															
		Sound power <sup>(1)</sup>	dB(A)	90,5	91,0	91,5	92,0	92,0	93,0	93,5	94,0	94,0	94,5	94,5	95,0
		Sound pressure at 10 m <sup>(2)</sup>	dB(A)	58,0	58,5	59,5	60,0	60,0	60,5	61,0	61,5	61,5	62,0	62,0	62,5
<b>Unit + option 15LS<sup>(3)</sup></b>															
		Sound power <sup>(1)</sup>	dB(A)	85,0	86,0	86,5	87,0	87,0	88,0	88,0	89,0	89,0	89,5	90,0	90,0
		Sound pressure at 10 m <sup>(2)</sup>	dB(A)	53,0	53,5	54,0	54,5	54,5	55,5	55,5	56,5	56,5	57,0	57,5	57,5

<b>Dimensions - standard unit</b>															
<b>Standard unit</b>															
		Length	mm	2410	2410	2410	2410	2410	3604	3604	3604	3604	4798	4798	4798
		Width	mm	2253	2253	2253	2253	2253	2253	2253	2253	2253	2253	2253	2253
		Height	mm	2324	2324	2324	2324	2324	2324	2324	2324	2324	2324	2324	2324
<b>Unit + option 307<sup>(3)</sup></b>															
		Length	mm	3604	3604	3604	3604	3604	4798	4798	4798	4798	5992	5992	5992

<b>Operating weight<sup>(4)</sup></b>															
		Standard unit	kg	1569	1575	1784	1811	1817	2394	2452	2672	2678	3154	3180	3430
		Unit + option 15LS <sup>(3)</sup>	kg	1652	1658	1892	1920	1926	2520	2579	2817	2823	3317	3343	3611
		Unit + option 15LS + option 116W <sup>(3)</sup>	kg	1787	1793	2039	2067	2073	2715	2774	3051	3057	3551	3614	3882
		Unit + option 15LS + option 116W + option 307 <sup>(3)</sup>	kg	2771	2777	3022	3049	3055	3725	3783	4060	4066	4551	4614	4882

\* In accordance with EN14511-3:2022.  
 \*\* In accordance with EN14825:2022, average climate conditions  
 HA1 Heating mode conditions: Water type heat exchanger water inlet/outlet temperature 30 °C/35 °C, outside air temperature tdb/twb = 7 °C db/6 °C wb, evaporator fouling factor 0 m<sup>2</sup>. k/W  
 HA2 Heating mode conditions: Water type heat exchanger water inlet/outlet temperature 40 °C/45 °C, outside air temperature tdb/twb = 7 °C db/6 °C wb, evaporator fouling factor 0 m<sup>2</sup>. k/W  
 CA1 Cooling mode conditions: evaporator water inlet/outlet temperature 12 °C/7 °C, outdoor air temperature 35 °C, evaporator fouling factor 0 m<sup>2</sup>. k/W  
**η<sub>s heat</sub><sub>30/35°C</sub> & SCOP<sub>30/35°C</sub>** Values in bold comply with Ecodesign Regulation (EU) No. 813/2013 for Heating applications  
**SEER<sub>12/7°C</sub> & SEPR<sub>12/7°C</sub>** Applicable Ecodesign regulation (EU) No. 2016/2281.  
 (1) In dB ref=10<sup>-12</sup> W, (A) weighting. Declared dual-number noise emission value in accordance with ISO 4871 with an uncertainty of +/-3 dB(A). Measured in accordance with ISO 9614-1 and certified by Eurovent. Cooling mode.  
 (2) In dB ref 20 μPa, (A) weighting. Declared dual-number noise emission value in accordance with ISO 4871 with an uncertainty of +/-3 dB(A). For information, calculated from the sound power Lw(A).  
 (3) Options: 15LS = Very low noise level, 116W = Variable-speed high pressure dual-pump hydraulic module, 307 = Water buffer tank module,  
 (4) Values are guidelines only. Refer to the unit name plate.



Eurovent certified values

## PHYSICAL DATA, SIZES 165R TO 520R

30RQP		165R	180R	210R	230R	270R	310R	330R	370R	400R	430R	470R	520R
<b>Compressors</b>		Hermetic Scroll 48,3 r/s											
Circuit A/C		1	1	2	2	2	2	2	2	2	3	3	4
Circuit B/D		2	2	2	2	2	3	3	4	4	4	4	4
Number of power stages		3	3	4	4	4	5	5	6	6	7	7	8
<b>Unit PED category</b>		III	III	III	III	III	III	IV	IV	IV	IV	IV	IV
<b>Refrigerant<sup>(4)</sup></b>		R32 / A2L /GWP= 675 as per AR4											
Circuit A/C	kg	10,5	10,5	16,0	16,0	16,0	16,0	18,0	18,0	18,0	29,0	29,0	35,0
	tCO <sub>2</sub> e	7,1	7,1	10,8	10,8	10,8	10,8	12,2	12,2	12,2	19,6	19,6	23,6
Circuit B/D	kg	16,0	16,0	16,0	16,0	16,0	28,5	28,5	34,0	34,0	34,5	35,0	35,0
	tCO <sub>2</sub> e	10,8	10,8	10,8	10,8	10,8	19,2	19,2	23,0	23,0	23,3	23,6	23,6
<b>Oil</b>													
Circuit A/C	l	6,6	6,6	13,2	13,2	13,2	13,2	13,2	13,2	13,2	22,8	22,8	30,4
Circuit B/D	l	13,2	13,2	13,2	13,2	13,2	22,8	22,8	30,4	30,4	30,4	30,4	30,4
<b>Capacity control</b>		SmartVu™											
Minimum capacity	%	33	33	25	25	25	20	20	17	17	14	14	13
<b>Condenser</b>		Grooved copper tubes and aluminium fins											
<b>Fans</b>		Axial Flying Bird 6 with rotating impeller											
<b>Standard unit</b>													
Quantity		3	3	4	4	4	5	5	6	6	7	7	8
Maximum total air flow	l/s	14460	14460	19280	19280	19280	24100	24100	28920	28920	33740	33740	38560
Maximum rotation speed	r/s	16	16	16	16	16	16	16	16	16	16	16	16
<b>Evaporator</b>		Direct expansion brazed-plate heat exchanger											
Water volume	l	16,2	16,2	16,2	20,7	20,7	38,7	48,6	48,6	48,6	48,6	52,2	58,5
Max. water-side operating pressure without hydraulic module	kPa	1000	1000	1000	1000	1000	1000	1000	1000	1000	1000	1000	1000
<b>Hydraulic module (option)</b>		Pump, Victaulic screen filter, relief valve, water and air vent valve, pressure sensors											
Pump		Centrifugal pump, monocell, 48,3 r/s, low or high pressure (as required), single or dual (as required)											
Expansion tank volume (option)	l	50	50	50	50	50	80	80	80	80	80	80	80
Buffer tank volume (option)	l	550	550	550	550	550	550	550	550	550	550	550	550
Max. water-side operating pressure with hydraulic module	kPa	400	400	400	400	400	400	400	400	400	400	400	400
<b>Water connections with or without hydraulic module</b>		Victaulic® type											
Connections Module 1 / Module 2 <sup>(a)</sup>	inches	3	3	3	3	3	4	4	4	4	4	4	4
External diameter Module 1 / Module 2 <sup>(a)</sup>	mm	88,5	88,6	88,7	88,8	88,9	114,3	114,4	114,5	114,6	114,7	114,8	114,9
<b>Casing paintwork</b>		Colour code RAL 7035											

(4) Values are guidelines only. Refer to the unit name plate.  
(a) Modules 1 and 2 only relate to sizes 620R to 1040R.

PHYSICAL DATA, SIZES 620R TO 1040R

30RQP			620R	660R	740R	800R	860R	940R	1040R	
<b>Heating</b>										
<b>Standard unit</b> Full load performances*	HA1	Nominal capacity	kW	635	673	774	812	883	935	1075
		COP	kW/kW	3,82	3,81	3,82	3,81	3,80	3,73	3,80
	HA2	Nominal capacity	kW	620	658	757	795	863	915	1052
		COP	kW/kW	3,10	3,09	3,10	3,09	3,10	3,03	3,10
Seasonal energy efficiency**	HA1	<b>SCOP</b> <sub>30/35°C</sub>	<b>kWh/kWh</b>	<b>3,87</b>	<b>3,86</b>	<b>3,90</b>	<b>3,91</b>	<b>3,92</b>	<b>3,89</b>	<b>3,96</b>
		<b>ηs heat</b> <sub>30/35°C</sub>	<b>%</b>	<b>152</b>	<b>151</b>	<b>153</b>	<b>153</b>	<b>154</b>	<b>153</b>	<b>155</b>
		P <sub>rated</sub>	kW	499	530	609	641	696	741	798
<b>Cooling</b>										
<b>Standard unit</b> Full load performances*	CA1	Nominal capacity	kW	604	648	723	761	825	878	999
		EER	kW/kW	2,85	2,80	2,82	2,76	2,81	2,74	2,73
Seasonal energy efficiency**		SEER <sub>12/7°C</sub> Comfort low temp.	kWh/kWh	4,78	4,81	4,88	4,87	4,81	4,75	4,81
		SEPR <sub>12/7°C</sub> Process high temp.	kWh/kWh	5,49	5,34	5,60	5,40	5,60	5,43	5,47
<b>Unit + option 15LS</b> Full load performances*	CA1	Nominal capacity	kW	569	610	682	716	778	827	941
		EER	kW/kW	2,66	2,59	2,63	2,56	2,64	2,55	2,54
Seasonal energy efficiency**		SEER <sub>12/7°C</sub> Comfort low temp.	kWh/kWh	4,73	4,76	4,91	4,78	4,94	4,86	4,75
		SEPR <sub>12/7°C</sub> Process high temp.	kWh/kWh	5,51	5,37	5,62	5,39	5,65	5,47	5,52
<b>Sound levels</b>										
<b>Standard unit</b>										
		Sound power <sup>(1)</sup>	dB(A)	96,0	96,5	97,0	97,0	97,5	97,5	98,0
		Sound pressure at 10 m <sup>(2)</sup>	dB(A)	63,5	64,0	64,5	64,5	65,0	65,0	65,5
<b>Unit + option 15LS<sup>(3)</sup></b>										
		Sound power <sup>(1)</sup>	dB(A)	91,0	91,0	92,0	92,0	92,5	93,0	93,0
		Sound pressure at 10 m <sup>(2)</sup>	dB(A)	58,5	58,5	59,5	59,5	60,0	60,5	60,5
<b>Dimensions - standard unit</b>										
<b>Standard unit</b>										
		Length	mm	7708	7708	7708	7708	10096	10096	10096
		Width	mm	2253	2253	2253	2253	2253	2253	2253
		Height	mm	2324	2324	2324	2324	2324	2324	2324
<b>Unit + option 307<sup>(3)</sup></b>										
		Length	mm	-	-	-	-	-	-	-
<b>Operating weight<sup>(4)</sup></b>										
		Standard unit	kg	4787	4905	5344	5356	6308	6360	6859
		Unit + option 15LS <sup>(3)</sup>	kg	5041	5158	5634	5646	6634	6686	7222
		Unit + option 15LS + option 116W <sup>(3)</sup>	kg	5430	5548	6102	6114	7103	7229	7764
		Unit + option 15LS + option 116W + option 307 <sup>(3)</sup>	kg	-	-	-	-	-	-	-

\* In accordance with EN14511-3:2022.  
 \*\* In accordance with EN14825:2022, average climate conditions  
 HA1 Heating mode conditions: Water type heat exchanger water inlet/outlet temperature 30 °C/35 °C, outside air temperature tdb/twb = 7 °C db/6 °C wb, evaporator fouling factor 0 m<sup>2</sup>. k/W  
 HA2 Heating mode conditions: Water type heat exchanger water inlet/outlet temperature 40 °C/45 °C, outside air temperature tdb/twb = 7 °C db/6 °C wb, evaporator fouling factor 0 m<sup>2</sup>. k/W  
 CA1 Cooling mode conditions: evaporator water inlet/outlet temperature 12 °C/7 °C, outdoor air temperature 35 °C, evaporator fouling factor 0 m<sup>2</sup>. k/W  
**ηs heat <sub>30/35°C</sub> & SCOP <sub>30/35°C</sub>** Values in bold comply with Ecodesign Regulation (EU) No. 813/2013 for Heating applications  
**SEER <sub>12/7 °C</sub> & SEPR <sub>12/7 °C</sub>** Applicable Ecodesign regulation (EU) No. 2016/2281.  
 (1) In dB ref=10<sup>-12</sup> W, (A) weighting. Declared dual-number noise emission value in accordance with ISO 4871 with an uncertainty of +/-3 dB(A). Measured in accordance with ISO 9614-1 and certified by Eurovent. Cooling mode.  
 (2) In dB ref 20 μPa, (A) weighting. Declared dual-number noise emission value in accordance with ISO 4871 with an uncertainty of +/-3 dB(A). For information, calculated from the sound power Lw(A).  
 (3) Options: 15LS = Very low noise level, 116W = Variable-speed high pressure dual-pump hydraulic module, 307 = Water buffer tank module,  
 (4) Values are guidelines only. Refer to the unit name plate.



Eurovent certified values



## PHYSICAL DATA, SIZES 620R TO 1040R

30RQP		620R	660R	740R	800R	860R	940R	1040R
<b>Compressors</b>		Hermetic Scroll 48,3 r/s						
Circuit A/C		2/2	2/2	2/2	2/2	3/3	3/3	4/4
Circuit B/D		3/3	3/3	4/4	4/4	4/4	4/4	4/4
Number of power stages		10	10	12	12	14	14	16
<b>Unit PED category</b>		III	IV	IV	IV	IV	IV	IV
<b>Refrigerant<sup>(4)</sup></b>		R32 / A2L /GWP= 675 as per AR4						
Circuit A/C	kg	16,0 / 16,0	18,0 / 18,0	18,0 / 18,0	18,0 / 18,0	29,0 / 29,0	29,0 / 29,0	35,0 / 35,0
	tCO <sub>2</sub> e	10,8 / 10,8	12,2 / 12,2	12,2 / 12,2	12,2 / 12,2	19,6 / 19,6	19,6 / 19,6	23,6 / 23,6
Circuit B/D	kg	28,5 / 28,5	28,5 / 28,5	34,0 / 34,0	34,0 / 34,0	34,5 / 34,5	35,0 / 35,0	35,0 / 35,0
	tCO <sub>2</sub> e	19,2 / 19,2	19,2 / 19,2	23,0 / 23,0	23,0 / 23,0	23,3 / 23,3	23,6 / 23,6	23,6 / 23,6
<b>Oil</b>								
Circuit A/C	l	13,2 / 13,2	13,2 / 13,2	13,2 / 13,2	13,2 / 13,2	22,8 / 22,8	22,8 / 22,8	30,4 / 30,4
Circuit B/D	l	22,8 / 22,8	22,8 / 22,8	30,4 / 30,4	30,4 / 30,4	30,4 / 30,4	30,4 / 30,4	30,4 / 30,4
<b>Capacity control</b>		SmartVu™						
Minimum capacity	%	10	10	8	8	7	7	6
<b>Condenser</b>		Grooved copper tubes and aluminium fins						
<b>Fans</b>		Axial Flying Bird 6 with rotating impeller						
<b>Standard unit</b>								
Quantity		10	10	12	12	14	14	16
Maximum total air flow	l/s	48200	48200	57840	57840	67480	67480	77120
Maximum rotation speed	r/s	16	16	16	16	16	16	16
<b>Evaporator</b>		Direct expansion brazed-plate heat exchanger						
Water volume	l	77,4	97,2	97,2	97,2	97,2	104,4	117
Max. water-side operating pressure without hydraulic module	kPa	1000	1000	1000	1000	1000	1000	1000
<b>Hydraulic module (option)</b>		Pump, Victaulic screen filter, relief valve, water and air vent valve, pressure sensors						
Pump		Centrifugal pump, monocoil, 48,3 r/s, low or high pressure (as required), single or dual (as required)						
Expansion tank volume (option)	l	-	-	-	-	-	-	-
Buffer tank volume (option)	l	-	-	-	-	-	-	-
Max. water-side operating pressure with hydraulic module	kPa	400	400	400	400	400	400	400
<b>Water connections with or without hydraulic module</b>		Victaulic® type						
Connections Module 1 / Module 2 <sup>(a)</sup>	inches	4 / 4	4 / 4	4 / 4	4 / 4	4 / 4	4 / 4	4 / 4
External diameter Module 1 / Module 2 <sup>(a)</sup>	mm	114,3 / 114,3	114,3 / 114,3	114,3 / 114,3	114,3 / 114,3	114,3 / 114,3	114,3 / 114,3	114,3 / 114,3
<b>Casing paintwork</b>		Colour code RAL 7035						

(4) Values are guidelines only. Refer to the unit name plate.

(a) Modules 1 and 2 only relate to sizes 620R to 1040R.



**ELECTRICAL DATA NOTES**

30RB		170R	190R	210R	230R	270R	310R	340R	380R	410R
<b>Power circuit supply</b>										
Nominal voltage	V-ph-Hz	400 - 3 - 50								
Voltage range	V	360 - 440								
<b>Control circuit supply</b>		24 V via internal transformer								
<b>Maximum operating input power <sup>(1) or (2)</sup></b>										
Circuit A&B	kW	74,6	81,2	90,8	99,4	118,6	133,9	148,3	163,5	178,4
<b>Power factor at maximum power <sup>(1) or (2)</sup></b>										
Standard unit power factor		0,83	0,83	0,83	0,83	0,83	0,83	0,83	0,83	0,85
<b>Maximum operating current draw (Un) <sup>(1) or (2)</sup></b>										
Standard unit	A	129,0	141,2	157,8	172,0	205,2	231,6	256,5	282,9	302,4
<b>Maximum current (Un-10%) <sup>(1) or (2)</sup></b>										
Standard unit	A	137,7	150,6	168,6	183,6	219,6	247,5	274,5	302,4	324
<b>Maximum start-up current (Un) <sup>(2) + (3)</sup></b>										
Standard unit	A	305	354	370	348	418	444	469	496	515
Unit + option 25/25E	A	262	302	318	305	366	392	417	444	463

30RB		450R	480R	550R	610R	670R	720R	770R	800R	870R	950R
<b>Power circuit supply</b>											
Nominal voltage	V-ph-Hz	400 - 3 - 50									
Voltage range	V	360 - 440									
<b>Control circuit supply</b>		24 V via internal transformer									
<b>Maximum operating input power <sup>(1) or (2)</sup></b>											
Circuit A&B	kW	193,7	208,1	237,8	256,4	282,7	306,1	328,5	340,2	374,4	405,6
<b>Power factor at maximum power <sup>(1) or (2)</sup></b>											
Standard unit power factor		0,85	0,85	0,85	0,84	0,84	0,84	0,84	0,84	0,84	0,84
<b>Maximum operating current draw (Un) <sup>(1) or (2)</sup></b>											
Standard unit	A	327,9	352,8	403,2	439,5	486,0	525,0	565,0	584,5	644,0	696,0
<b>Maximum current (Un-10%) <sup>(1) or (2)</sup></b>											
Standard unit	A	351	378	432	472	522	564	607	628	692	748
<b>Maximum start-up current (Un) <sup>(2) + (3)</sup></b>											
Standard unit	A	541	565	616	770	823	856	902	915	981	1027
Unit + option 25/25E	A	489	513	564	687	740	773	819	832	898	944

(1) Values at the unit's permanent maximum operating condition (as shown on the unit's nameplate).  
 (2) Values at the unit's maximum operating condition (as shown on the unit's nameplate).  
 (3) Maximum operating current of the smallest compressor(s) + fan current + locked rotor current of the largest compressor.

## ELECTRICAL DATA NOTES

30RBP		170R	190R	210R	230R	270R	310R	340R	380R	410R
<b>Power circuit supply</b>										
Nominal voltage	V-ph-Hz	400 - 3 - 50								
Voltage range	V	360 - 440								
<b>Control circuit supply</b>		24 V via internal transformer								
<b>Maximum operating input power <sup>(1) or (2)</sup></b>										
Circuit A&B	kW	74,8	81,5	91,1	99,8	118,9	134,3	148,7	164	178,4
<b>Power factor at maximum power <sup>(1) or (2)</sup></b>										
Standard unit power factor		0,85	0,85	0,85	0,85	0,85	0,85	0,85	0,85	0,85
<b>Maximum operating current draw (Un) <sup>(1) or (2)</sup></b>										
Standard unit	A	126,3	137,6	154,2	168,4	201,6	227,1	252,0	277,5	302,4
<b>Maximum current (Un-10%) <sup>(1) or (2)</sup></b>										
Standard unit	A	135	147	165	180	216	243	270	297	324
<b>Maximum start-up current (Un) <sup>(2) + (3)</sup></b>										
Standard unit	A	302	350	367	344	414	440	465	490	515
Unit + option 25/25E	A	259	298	315	301	362	388	413	438	463

30RBP		450R	480R	550R	610R	670R	720R	770R	800R	870R	950R
<b>Power circuit supply</b>											
Nominal voltage	V-ph-Hz	400 - 3 - 50									
Voltage range	V	360 - 440									
<b>Control circuit supply</b>		24 V via internal transformer									
<b>Maximum operating input power <sup>(1) or (2)</sup></b>											
Circuit A&B	kW	193,7	208,1	237,8	256,4	282,7	306,1	328,5	340,2	374,4	405,6
<b>Power factor at maximum power <sup>(1) or (2)</sup></b>											
Standard unit power factor		0,85	0,85	0,85	0,84	0,84	0,84	0,84	0,84	0,84	0,84
<b>Maximum operating current draw (Un) <sup>(1) or (2)</sup></b>											
Standard unit	A	327,9	352,8	403,2	439,5	486,0	525,0	565,0	584,5	644,0	696,0
<b>Maximum current (Un-10%) <sup>(1) or (2)</sup></b>											
Standard unit	A	351	378	432	472	522	564	607	628	692	748
<b>Maximum start-up current (Un) <sup>(2) + (3)</sup></b>											
Standard unit	A	541	565	616	770	823	856	902	915	981	1027
Unit + option 25/25E	A	489	513	564	687	740	773	819	832	898	944

- (1) Values at the unit's permanent maximum operating condition (as shown on the unit's nameplate).  
(2) Values at the unit's maximum operating condition (as shown on the unit's nameplate).  
(3) Maximum operating current of the smallest compressor(s) + fan current + locked rotor current of the largest compressor.



**ELECTRICAL DATA NOTES**

30RQ		165R	180R	210R	230R	270R	310R	330R	370R	400R	430R	470R	520R
<b>Power circuit supply</b>													
Nominal voltage	V-ph-Hz	400 - 3 - 50											
Voltage range	V	360 - 440											
<b>Control circuit supply</b>													
24 V via internal transformer													
<b>Maximum operating input power <sup>(1) or (2)</sup></b>													
Circuit A&B	kW	74,6	84,2	99,4	109,0	118,6	138,7	148,3	168,3	177,9	193,2	207,6	237,2
<b>Power factor at maximum power <sup>(1) or (2)</sup></b>													
Standard unit power factor		0,83	0,83	0,83	0,83	0,83	0,83	0,83	0,83	0,83	0,83	0,83	0,83
<b>Maximum operating current draw (Un) <sup>(1) or (2)</sup></b>													
Standard unit	A	129	145,6	172	188,6	205,2	239,9	256,5	291,2	307,8	334,2	359,1	410,4
<b>Maximum current (Un-10%) <sup>(1) or (2)</sup></b>													
Standard unit	A	140,7	156,7	187,6	203,6	219,6	258,5	274,5	313,4	329,4	360,3	384,3	439,2
<b>Maximum start-up current (Un) <sup>(2) + (3)</sup></b>													
Standard unit	A	305	362	348	401	418	453	469	504	520	547	572	623
Unit + option 25/25E	A	262	310	305	349	366	401	417	452	468	495	520	571

30RQP		165R	180R	210R	230R	270R	310R	330R	370R	400R
<b>Power circuit supply</b>										
Nominal voltage	V-ph-Hz	400 - 3 - 50								
Voltage range	V	360 - 440								
<b>Control circuit supply</b>										
24 V via internal transformer										
<b>Maximum operating input power <sup>(1) or (2)</sup></b>										
Circuit A&B (Module 1 / Module 2) <sup>(a)</sup>	kW	74,8	84,4	99,8	109,3	118,9	139,2	148,7	169	178,6
<b>Power factor at maximum power <sup>(1) or (2)</sup></b>										
Standard unit power factor		0,85	0,85	0,85	0,85	0,85	0,85	0,85	0,85	0,85
<b>Maximum operating current draw (Un) <sup>(1) or (2)</sup></b>										
Standard unit (Module 1 / Module 2) <sup>(a)</sup>	A	126,3	142,9	168,4	185	201,6	235,4	252	285,8	302,4
<b>Maximum current (Un-10%) <sup>(1) or (2)</sup></b>										
Standard unit (Module 1 / Module 2) <sup>(a)</sup>	A	138	154	184	200	216	254	270	308	324
<b>Maximum start-up current (Un) <sup>(2) + (3)</sup></b>										
Standard unit (Module 1 / Module 2) <sup>(a)</sup>	A	302	359	344	398	414	448	465	498	515
Unit + option 25/25E (Module 1 / Module 2) <sup>(a)</sup>	A	259	307	301	346	362	396	413	446	463

30RQP		430R	470R	520R	620R	660R	740R	800R	860R	940R	1040R
<b>Power circuit supply</b>											
Nominal voltage	V-ph-Hz	400 - 3 - 50									
Voltage range	V	360 - 440									
<b>Control circuit supply</b>											
24 V via internal transformer											
<b>Maximum operating input power <sup>(1) or (2)</sup></b>											
Circuit A&B (Module 1 / Module 2) <sup>(a)</sup>	kW	193,9	208,3	237,8	139,2 / 139,2	148,7 / 148,7	169,0 / 169,0	178,6 / 178,6	193,7 / 193,7	208,1 / 208,1	237,8 / 237,8
<b>Power factor at maximum power <sup>(1) or (2)</sup></b>											
Standard unit power factor		0,85	0,85	0,85	0,85	0,85	0,85	0,85	0,85	0,85	0,85
<b>Maximum operating current draw (Un) <sup>(1) or (2)</sup></b>											
Standard unit (Module 1 / Module 2) <sup>(a)</sup>	A	327,9	352,8	403,2	235,4 / 235,4	252 / 252	285,8 / 285,8	302,4 / 302,4	327,9 / 327,9	352,8 / 352,8	403,2 / 403,2
<b>Maximum current (Un-10%) <sup>(1) or (2)</sup></b>											
Standard unit (Module 1 / Module 2) <sup>(a)</sup>	A	354	378	432	254 / 254	270 / 270	308 / 308	324 / 324	354 / 354	378 / 378	432 / 432
<b>Maximum start-up current (Un) <sup>(2) + (3)</sup></b>											
Standard unit (Module 1 / Module 2) <sup>(a)</sup>	A	541	565	616	448 / 448	465 / 465	498 / 498	515 / 515	541 / 541	565 / 565	616 / 616
Unit + option 25/25E (Module 1 / Module 2) <sup>(a)</sup>	A	489	513	564	396 / 396	413 / 413	446 / 446	463 / 463	489 / 489	513 / 513	564 / 564

(1) Values at the unit's permanent maximum operating condition (as shown on the unit's nameplate).  
 (2) Values at the unit's maximum operating condition (as shown on the unit's nameplate).  
 (3) Maximum operating current of the smallest compressor(s) + fan current + locked rotor current of the largest compressor.  
 (a) Modules 1 and 2 only relate to sizes 620R to 1040R.

## ELECTRICAL DATA NOTES

### Short-circuit withstand current (TN system)<sup>(1)</sup>

30RB-RBP	170R	190R	210R	230R	270R	310R	340R	380R	410R	450R
<b>Rated short-circuit withstand currents</b>										
Rated short time (1s) current - I <sub>cw</sub>	kA eff	5,5	8,5	8,5	8,5	8,5	20	20	20	20
Rated peak current - I <sub>pk</sub>	kA pk	154	330	330	330	330	330	330	330	330
<b>Value with upstream electrical protection<sup>(1)</sup></b>										
Rated conditional short circuit current I <sub>cc</sub>	kA eff	50	50	50	50	50	50	50	50	50
Associated protection		NSX160N / =S=	NSX250N / =S=	NSX250N / =S=	NSX250N / =S=	NSX250N / =S=	NSX250N / =S=	NSX400N / =S=	NSX400N / =S=	NSX400N / =S=
Associated protection		TM160D / LV430840	TM200D / LV431831	TM200D / LV431831	TM250D / LV431831	TM250D / LV431831	TM250D / LV431831	Micrologic 2,3 400 A / LV432693	Micrologic 2,3 400 A / LV432693	Micrologic 2,3 400 A / LV432693

30RB-RBP	480R	550R	610R	670R	720R	770R	820R	870R	950R
<b>Rated short-circuit withstand currents</b>									
Rated short time (1s) current - I <sub>cw</sub>	kA eff	20	20	20	20	20	35	35	35
Rated peak current - I <sub>pk</sub>	kA pk	330	330	330	330	330	330	330	330
<b>Value with upstream electrical protection<sup>(1)</sup></b>									
Rated conditional short circuit current I <sub>cc</sub>	kA eff	50	50	50	50	50	50	50	50
Associated protection		NSX630N / =S=	NSX630N / =S=	NSX630N / =S=	NSX630N / =S=	NSX630N / =S=	NS800 / =S=	NS800 / =S=	NS800 / =S=
Associated protection		Micrologic 2,3 630 A / LV432893	Micrologic 2,3 630 A / LV432893	Micrologic 2,3 630 A / LV432893	Micrologic 2,3 630 A / LV432893	Micrologic 2,3 630 A / LV432893	Micrologic 5,0 800 A / 34426	Micrologic 5,0 800 A / 34426	Micrologic 5,0 800 A / 34426

(1) If another current limitation protection device is used, its time-current and thermal constraint (I<sup>2t</sup>) trip characteristics must be at least equivalent to those of the recommended protection.

**Note: The short-circuit withstand current capability values above have been established for the TN system.**





**ELECTRICAL DATA NOTES**

30RQ-RQP		165R	180R	210R	230R	270R	310R	330R	370R	400R	430R
<b>Rated short-circuit withstand currents</b>											
Rated short time (1s) current - I <sub>cw</sub> (Module 1 / Module 2) <sup>(a)</sup>	kA eff	5,5	8,5	8,5	8,5	8,5	20	20	20	20	20
Rated peak current - I <sub>pk</sub> (Module 1 / Module 2) <sup>(a)</sup>	kA pk	154	330	330	330	330	330	330	330	330	330
<b>Value with upstream electrical protection<sup>(1)</sup></b>											
Rated conditional short circuit current I <sub>cc</sub> (Module 1 / Module 2) <sup>(a)</sup>	kA eff	50	50	50	50	50	50	50	50	50	50
Associated protection - type (Module 1/Module 2) <sup>(a)</sup>		INS250	INS250	INS250	INS250	INS250	INS400	INS400	INS400	INS400	INS400
Associated protection (rating/reference)	Module 1 <sup>(a)</sup>	TM160D / LV430840	TM200D / LV431831	TM250D / LV431831	TM250D / LV431831	TM250D / LV431831	Micrologic 2,3 400 A / LV432693	Micrologic 2,3 400 A / LV432693	Micrologic 2,3 400 A / LV432693	Micrologic 2,3 400 A / LV432693	Micrologic 2,3 400 A / LV432693
	Module 2 <sup>(a)</sup>	-	-	-	-	-	-	-	-	-	-

30RQ-RQP		470R	520R	620R	660R	740R	800R	860R	940R	1040R
<b>Rated short-circuit withstand currents</b>										
Rated short time (1s) current - I <sub>cw</sub> (Module 1 / Module 2) <sup>(a)</sup>	kA eff	20	20	20 / 20	20 / 20	20 / 20	20 / 20	20 / 20	20 / 20	20 / 20
Rated peak current - I <sub>pk</sub> (Module 1 / Module 2) <sup>(a)</sup>	kA pk	330	330	330 / 330	330 / 330	330 / 330	330 / 330	330 / 330	330 / 330	330 / 330
<b>Value with upstream electrical protection<sup>(1)</sup></b>										
Rated conditional short circuit current I <sub>cc</sub> (Module 1 / Module 2) <sup>(a)</sup>	kA eff	50	50	50 / 50	50 / 50	50 / 50	50 / 50	50 / 50	50 / 50	50 / 50
Associated protection - type (Module 1/Module 2) <sup>(a)</sup>		INS500	INS500	INS400 / INS400	INS400 / INS400	INS400 / INS400	INS400 / INS400	INS400 / INS400	INS500 / INS500	INS500 / INS500
Associated protection (rating/reference)	Module 1 <sup>(a)</sup>	Micrologic 2,3 630 A / LV432893	Micrologic 2,3 630 A / LV432893	Micrologic 2,3 400 A / LV432693	Micrologic 2,3 400 A / LV432693	Micrologic 2,3 400 A / LV432693	Micrologic 2,3 400 A / LV432693	Micrologic 2,3 400 A / LV432693	Micrologic 2,3 630 A / LV432893	Micrologic 2,3 630 A / LV432893
	Module 2 <sup>(a)</sup>	-	-	Micrologic 2,3 400 A / LV432693	Micrologic 2,3 400 A / LV432693	Micrologic 2,3 400 A / LV432693	Micrologic 2,3 400 A / LV432693	Micrologic 2,3 400 A / LV432693	Micrologic 2,3 630 A / LV432893	Micrologic 2,3 630 A / LV432893

(1) If another current limitation protection device is used, its time-current and thermal constraint (I<sup>2</sup>t) trip characteristics must be at least equivalent to those of the recommended protection.

(a) Modules 1 and 2 only relate to sizes 620R to 1040R.

**Note: The short-circuit withstand current capability values above have been established for the TN system.**



## DIMENSIONS/CLEARANCES

### 30RB/30RBP 170R-270R, 30RQ/30RQP 165R-270R (with and without hydraulic module)

#### Without hydraulic module

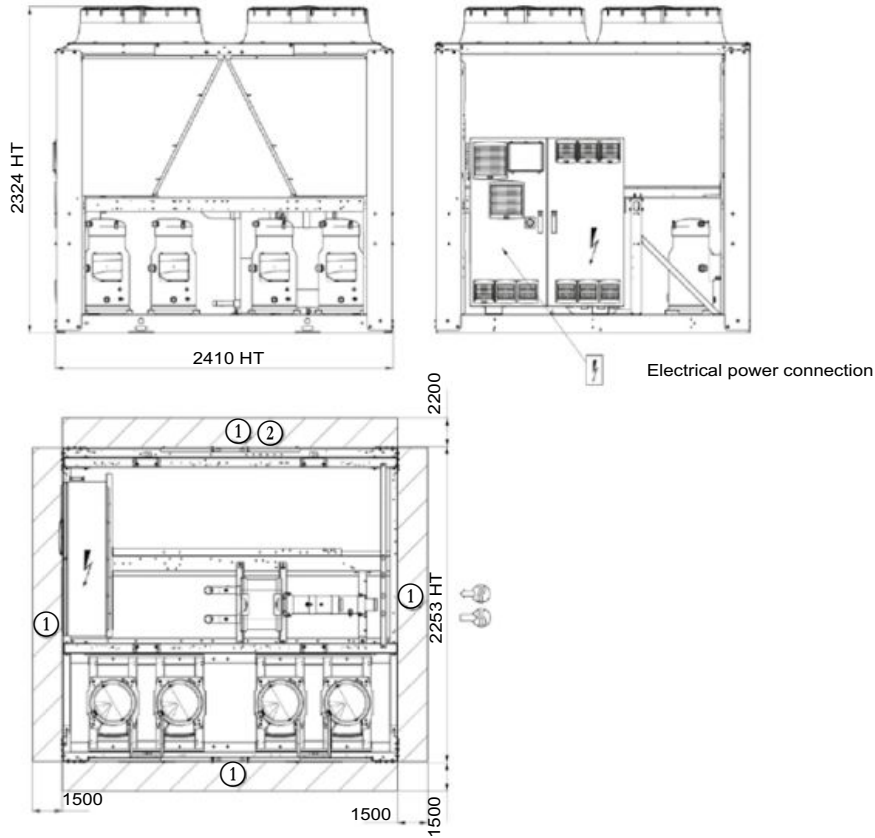

#### With hydraulic module

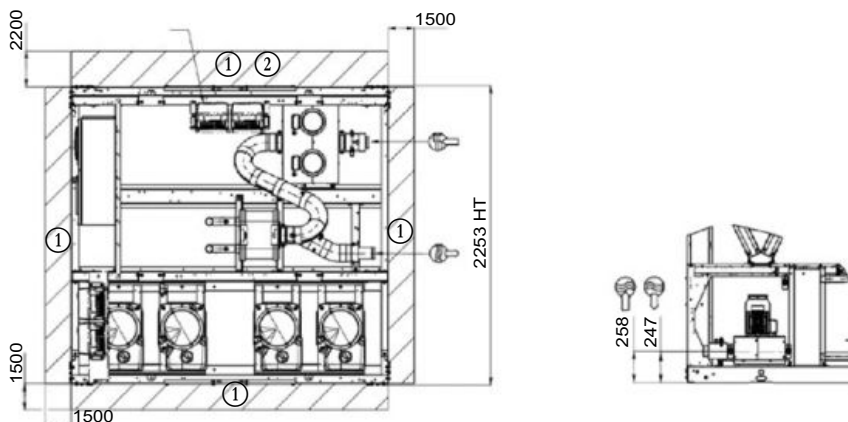

**Key:**

All dimensions are given in mm.

- ① Clearances required for maintenance and air flow
- ② Clearance recommended for removal of the coils
- Water inlet
- Water outlet
- Air outlet, do not obstruct
- Electrical cabinet

**Note: Drawings are not contractually binding. Before designing an installation, consult the certified dimensional drawings, available on request.**

**Refer to the certified dimensional drawings for the location of fixing points, weight distribution and coordinates of the centre of gravity.**



## DIMENSIONS/CLEARANCES

### 30RB/30RBP 310R-410R, 30RQ/30RQP 310R-400R (with and without hydraulic module)

#### Without hydraulic module

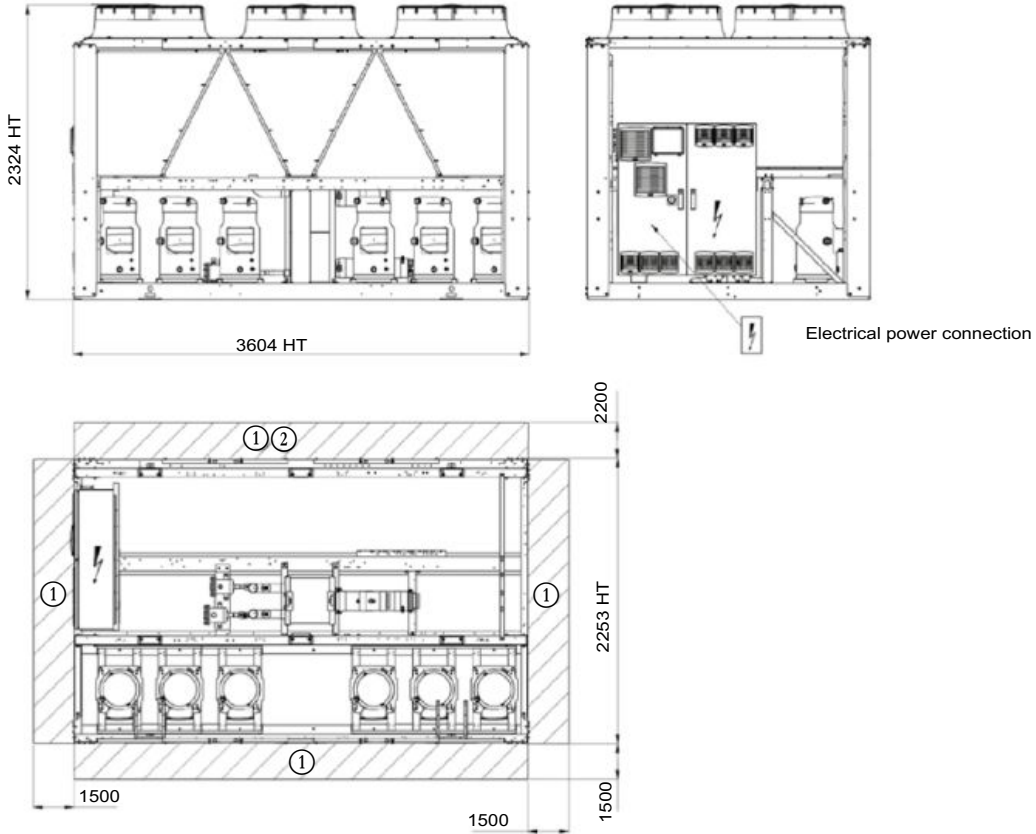

#### With hydraulic module

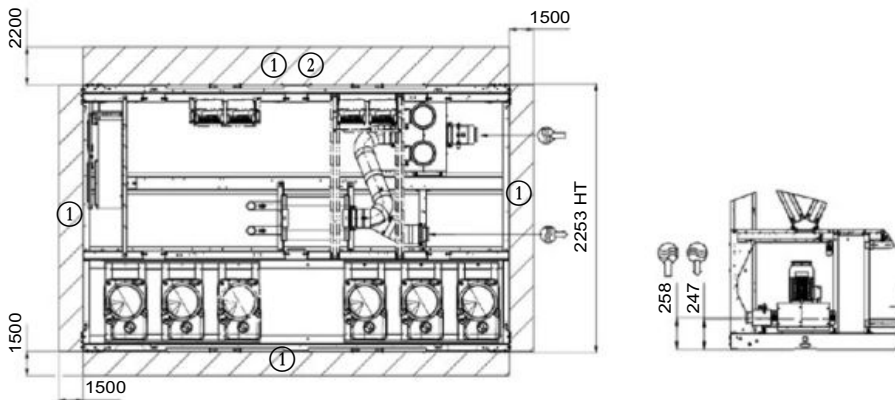

**Key:**

All dimensions are given in mm.

- ① Clearances required for maintenance and air flow
- ② Clearance recommended for removal of the coils

- Water inlet
- Water outlet
- Air outlet, do not obstruct
- Electrical cabinet

**Note: Drawings are not contractually binding. Before designing an installation, consult the certified dimensional drawings, available on request.**

**Refer to the certified dimensional drawings for the location of fixing points, weight distribution and coordinates of the centre of gravity.**



## DIMENSIONS/CLEARANCES

### 30RB/30RBP 450R-550R, 30RQ/30RQP 430R-520R (with and without hydraulic module)

#### Without hydraulic module

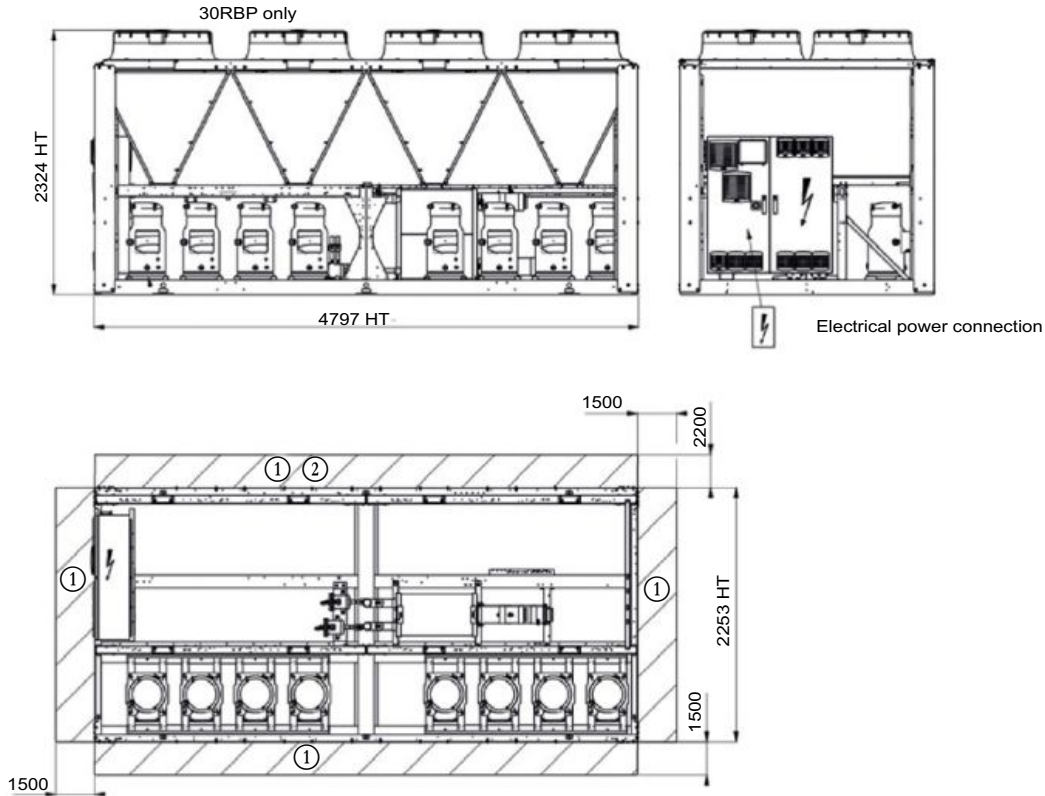

#### With hydraulic module

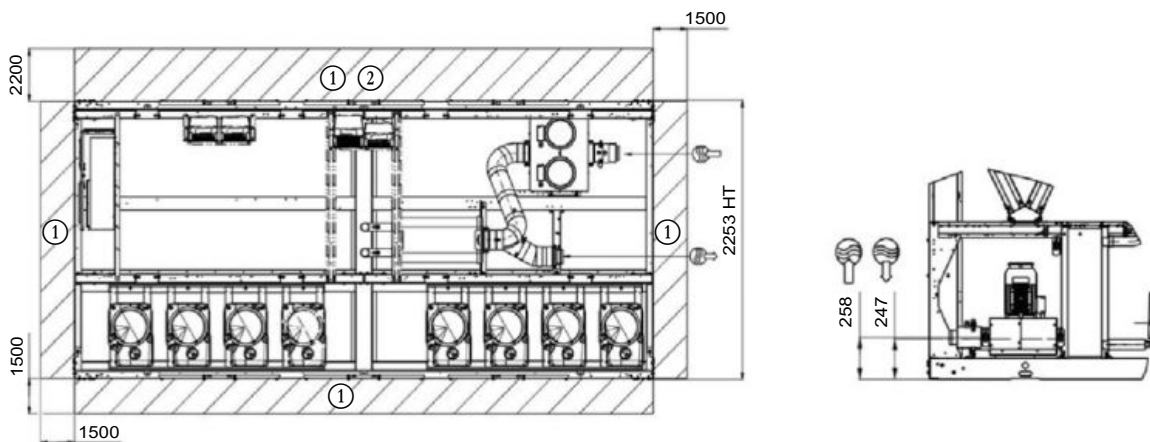

**Key:**

All dimensions are given in mm.

- ① Clearances required for maintenance and air flow
- ② Clearance recommended for removal of the coils

Water inlet

Water outlet

Air outlet, do not obstruct

Electrical cabinet

**Note: Drawings are not contractually binding. Before designing an installation, consult the certified dimensional drawings, available on request.**

**Refer to the certified dimensional drawings for the location of fixing points, weight distribution and coordinates of the centre of gravity.**



## DIMENSIONS/CLEARANCES

### 30RB/30RBP 610R-720R (with and without hydraulic module)

#### Without hydraulic module

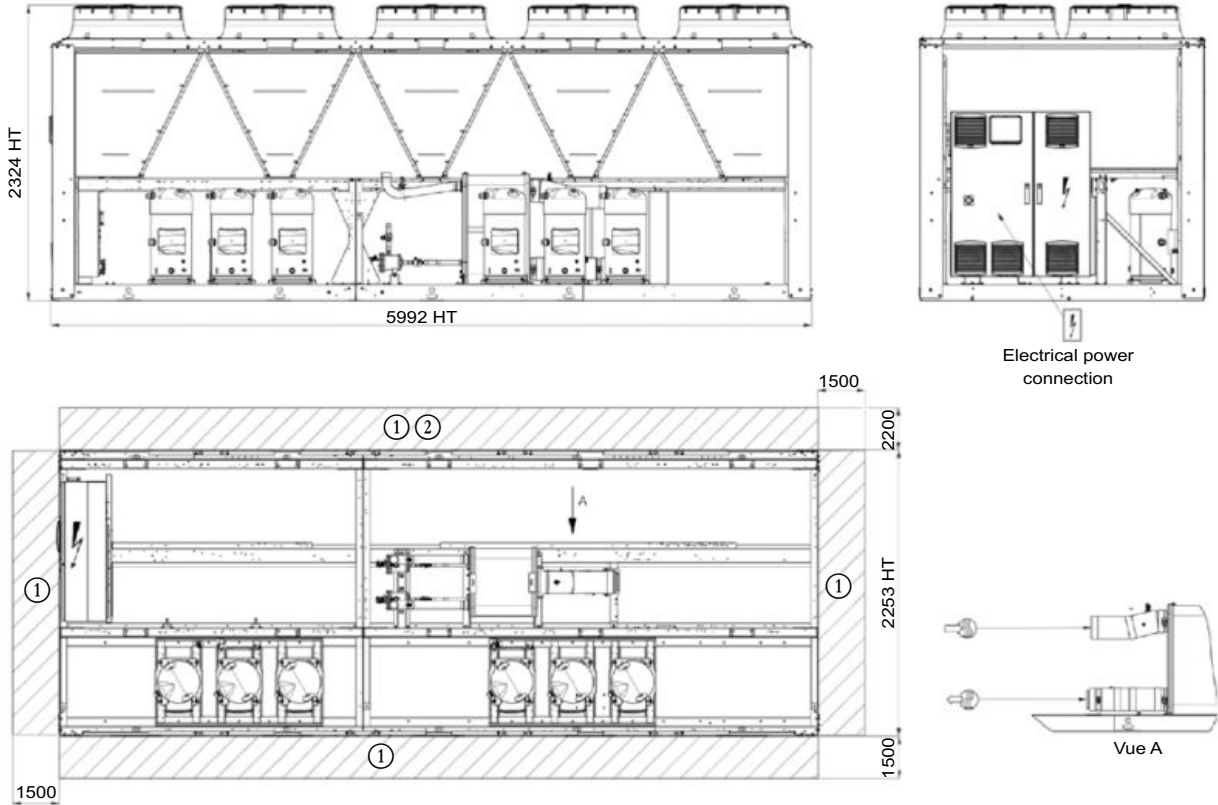

#### With hydraulic module

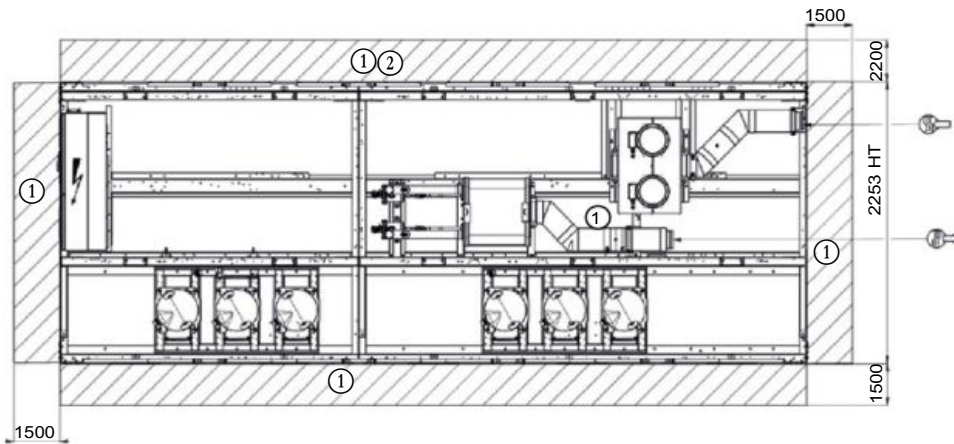

**Key:**

All dimensions are given in mm.

- ① Clearances required for maintenance and air flow
- ② Clearance recommended for removal of the coils

- Water inlet
- Water outlet
- Air outlet, do not obstruct
- Electrical cabinet

**Note: Drawings are not contractually binding. Before designing an installation, consult the certified dimensional drawings, available on request.**

**Refer to the certified dimensional drawings for the location of fixing points, weight distribution and coordinates of the centre of gravity.**





## DIMENSIONS/CLEARANCES

### 30RB/30RBP 770R-950R (with and without hydraulic module)

#### Without hydraulic module

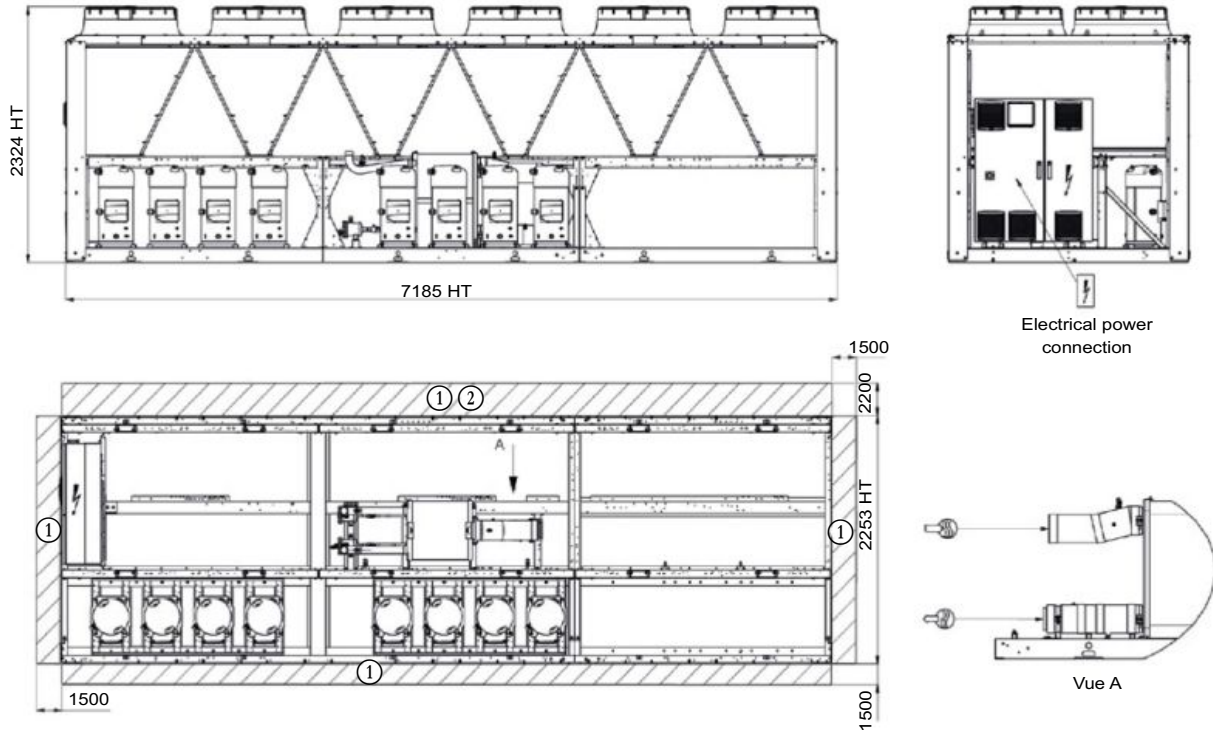

#### With hydraulic module

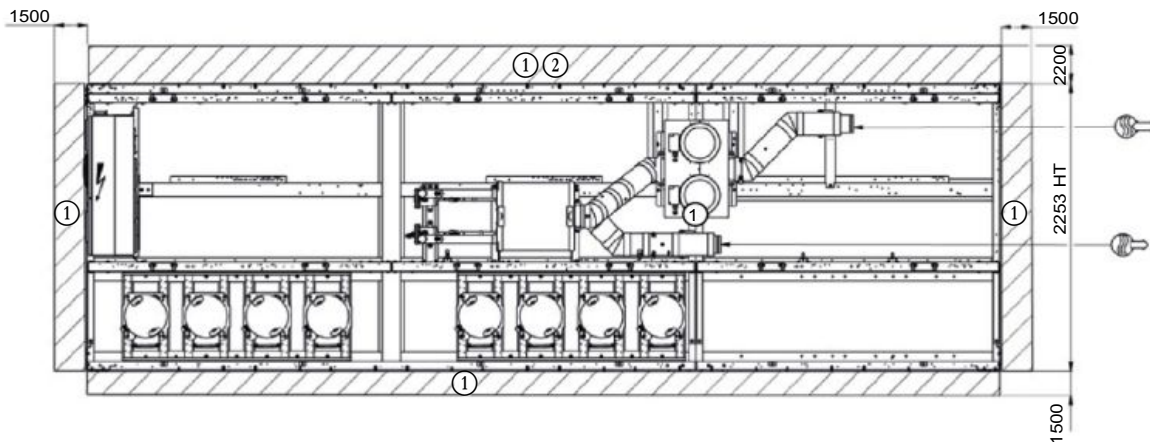

**Key:**

All dimensions are given in mm.

- ① Clearances required for maintenance and air flow
- ② Clearance recommended for removal of the coils

Water inlet

Water outlet

Air outlet, do not obstruct

Electrical cabinet

**Note: Drawings are not contractually binding. Before designing an installation, consult the certified dimensional drawings, available on request.**

**Refer to the certified dimensional drawings for the location of fixing points, weight distribution and coordinates of the centre of gravity.**



## DIMENSIONS/CLEARANCES

### 30RQP 620R-1040R (with and without hydraulic module)

#### Without hydraulic module

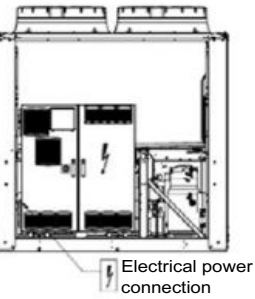
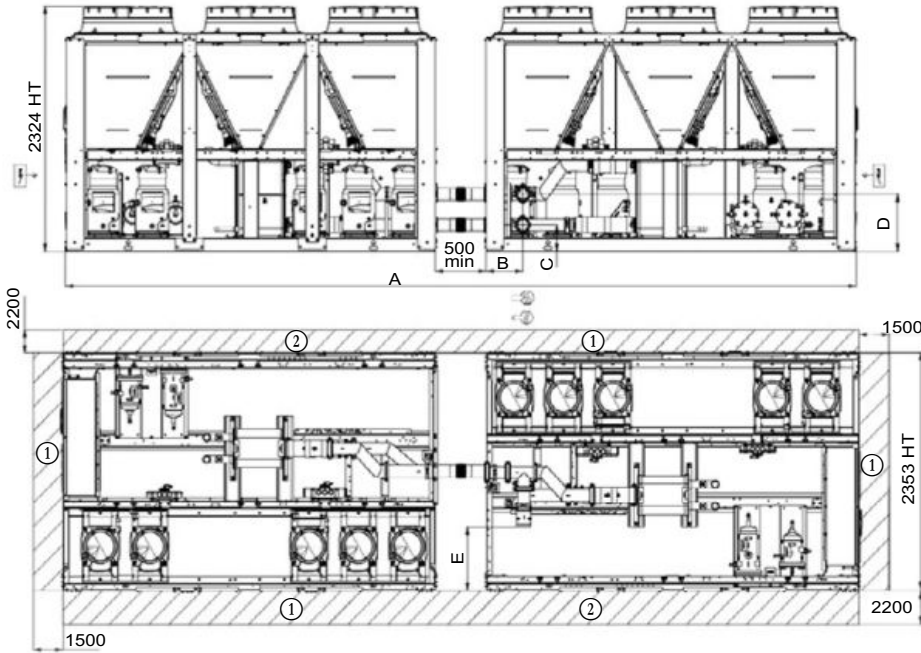

30RQP	620R to 800R	860R to 1040R
Length A (mm)	7680	10068
Length B (mm)	357	357
Length C (mm)	251	251
Length D (mm)	544	544
Length E (mm)	597	597
Victaulic	5"	5"

#### With hydraulic module

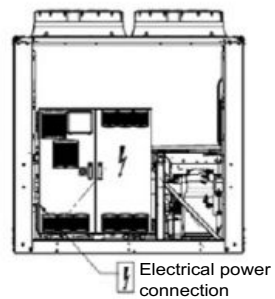
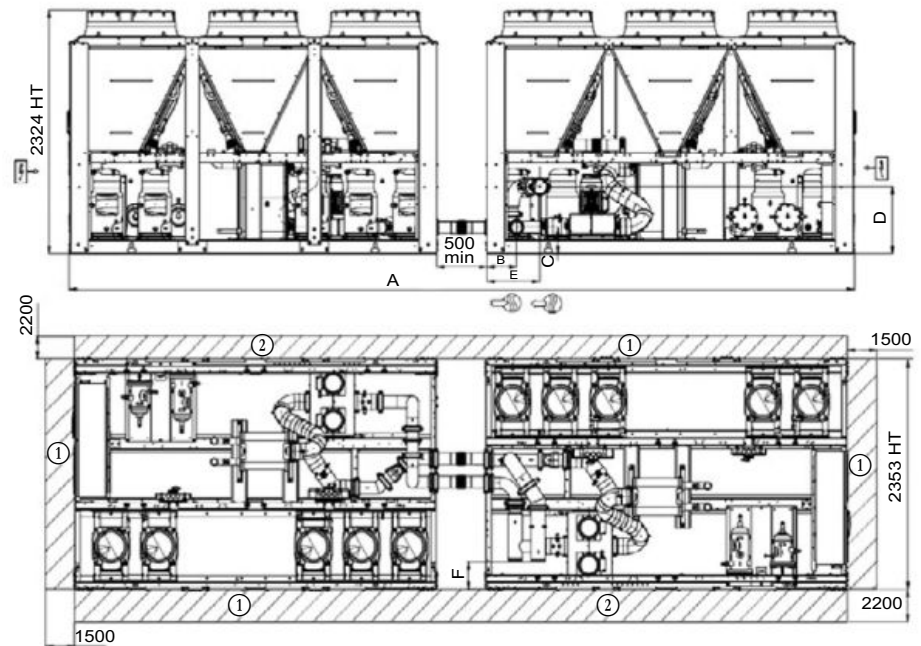

30RQP	620R to 800R	860R to 1040R
Length A (mm)	7680	10068
Length B (mm)	290	251
Length C (mm)	254	254
Length D (mm)	640	640
Length E (mm)	516	509
Length F (mm)	265	265
Victaulic	5"	5"

**Key:**

All dimensions are given in mm.

- ① Clearances required for maintenance and air flow
- ② Clearance recommended for removal of the coils

- Water inlet
- Water outlet
- Air outlet, do not obstruct
- Electrical cabinet

**Note: Drawings are not contractually binding. Before designing an installation, consult the certified dimensional drawings, available on request.**

**Refer to the certified dimensional drawings for the location of fixing points, weight distribution and coordinates of the centre of gravity.**

## VARIABLE-SPEED SCREW LIQUID CHILLER WITH GREENSPEED® INTELLIGENCE



- Outstanding performance
- Low sound levels
- Intelligence and connectivity
- Wide range of applications
- Simple installation and maintenance

# 30KAV 500A - 1100A 30KAVP 500A - 1100A

Nominal cooling capacity 493-1079 kW

The AquaForce® Vision 30KAV/30KAVP liquid chillers with Greenspeed® Intelligence are the premium solution for commercial applications where installers, consultants and building owners require superior reliability and optimal performances, especially at part load.

The 30KAV/30KAVP units are designed to exceed European Ecodesign directive requirements in terms of energy efficiency, versatility and operating sound levels. This result is achieved through the optimised combination of proven best-in-class technologies that include:

- 2<sup>nd</sup> generation of high-efficiency variable-speed twin screw compressors with built in volume index control (Vi) valve for optimal full and part load performance and Integrated Resonator Array (IRA) for low sound operation
- 30KAVP premium efficiency with a Permanent Magnet technology motor. Motor is synchronous and spins without any slip and rotor losses.
- 6<sup>th</sup> generation of Carrier Flying Bird™ fans with AC or EC motor depending on options.
- Carrier flooded shell-and-tube evaporator with new copper tubes for low pressure drops
- 3<sup>rd</sup> generation of “W” profile Carrier Novation™ microchannel heat exchangers with optional Enviro-Shield coatings.
- Carrier SmartVu™ control with color touch screen user interface that includes 10 languages and new smart energy monitoring function.



CARRIER participates in the ECP programme for LCP-HP  
Check ongoing validity of certificate:  
[www.eurovent-certification.com](http://www.eurovent-certification.com)



## 30KAV CUSTOMER BENEFITS

### ■ Outstanding performance

Equipped with variable-speed screw compressors and variable-speed fans (AC as standard and EC as option) and optional variable-speed pumps, Carrier's AquaForce® Vision 30KAV chiller with Greenspeed™ intelligence automatically adjusts the cooling capacity and the water flow to perfectly match the needs of the building or the process load variations. The result is optimum operation at both full load and part load (SEER up to 5.4). 30KAV offers energy efficiency up to 10% higher than the 30XAV range with the same footprint.

The range is already fully compliant with the 2021 Ecodesign regulations.



SEER  
up to 5.4

### ■ Low sound levels

The new generation of Carrier 06Z variable-speed twin screw compressor with integrated resonator array and the 6th generation of Flying Bird™ fans with new fan blade design inspired by nature help reduce compressor and airflow noise down to as little as 90 dB(A). 30KAV is 6 dB(A) quieter than the previous AquaForce® 30XAV generation.



90 dB(A)

### ■ Intelligence and connectivity

The advanced SmartVu™ intelligent control system displays operating parameters in real time, making it intuitive and particularly user-friendly. 30KAV also features innovative smart energy monitoring, providing users with smart data such as real time electric energy consumption, cooling energy output and instantaneous and average seasonal energy efficiency ratios. For further energy savings, 30KAV can be monitored remotely by Carrier experts for energy consumption diagnosis and optimization.



SMART ENERGY  
MONITORING

### ■ Extensive scope of application

Carrier's AquaForce® Vision adapts effortlessly to a wide range of applications. Extended operating temperatures from -20°C to 55°C outdoor air temperatures and negative water temperatures make it ideal for various sectors of activity. From high-end office buildings and hotels to healthcare facilities, data centers and industrial projects, AquaForce® Vision 30KAV meets the most demanding expectations in terms of energy efficiency and savings, whatever the climate and wherever the location.



FROM  
-20°C  
to 55°C

### ■ Easy installation & maintenance

Built-in variable-speed pumps up to 800 kW, automatic nominal water flow adjustment through electronic control, automatic unit energy performance measurement under real conditions, in units that are 25% smaller than the previous 30XAV generation, all these new features provide peace of mind for installers and service companies alike.



25%  
SMALLER



## 30KAVP CUSTOMER BENEFITS

### ■ Outstanding performance

Equipped with variable-speed screw compressors with permanent magnet motor, EC fans and extra condensing surface, Carrier's AquaForce® Vision 30KAVP chiller with Greenspeed™ intelligence automatically adjusts the cooling capacity and the water flow to perfectly match the needs of the building or the process load variations.

The SEER is 25% above 2021 Ecodesign requirements.



SEER  
up to 5.6

### ■ Low sound levels

The new generation of Carrier 06Z variable-speed twin screw compressor with integrated resonator array and the 6th generation of Flying Bird™ fans with new fan blade design inspired by nature help reduce compressor and airflow noise down to as little as 90 dB(A). 30KAVP is 6 dB(A) quieter than the previous AquaForce® 30XAV generation.



90 dB(A)

### ■ Intelligence and connectivity

The advanced SmartVu™ intelligent control system displays operating parameters in real time, making it intuitive and particularly user-friendly. 30KAVP also features innovative smart energy monitoring, providing users with smart data such as real time electric energy consumption, cooling energy output and instantaneous and average seasonal energy efficiency ratios. For further energy savings, 30KAVP can be monitored remotely by Carrier experts for energy consumption diagnosis and optimization.



SMART ENERGY  
MONITORING

### ■ Extensive scope of application

Carrier's AquaForce® Vision adapts effortlessly to a wide range of applications. Extended operating temperatures from -20°C to 55°C outdoor air temperatures and negative water temperatures make it ideal for various sectors of activity. From high-end office buildings and hotels to healthcare facilities, data centers and industrial projects, AquaForce® Vision 30KAVP meets the most demanding expectations in terms of energy efficiency and savings, whatever the climate and wherever the location.



FROM  
-20°C  
to 55°C

### ■ Easy installation & maintenance

Built-in variable-speed pumps up to 800 kW, automatic nominal water flow adjustment through electronic control, automatic unit energy performance measurement under real conditions, in units that are 25% smaller than the previous 30XAV generation, all these new features provide peace of mind for installers and service companies alike.



25%  
SMALLER



## CUSTOMER BENEFITS

AquaForce® Vision 30KAV/30KAVP liquid chillers with Greenspeed® Intelligence adapt effortlessly to a wide range of applications. An extended operating range covering ambient temperatures from -20 to 55°C makes it ideal for all areas of activity. From high-end office buildings and hotels to healthcare facilities, data centers and industrial projects, 30KAV/30KAVP meets the most demanding expectations in terms of energy efficiency and savings, whatever the climate and wherever the location.

Furthermore, the advanced SmartVu™ intelligent control system displays operating parameters in real time, making it intuitive and particularly user-friendly. 30KAV/30KAVP also features innovative smart energy monitoring, providing users with smart data such as real time electric energy consumption, cooling capacity, and instantaneous and average seasonal energy efficiency ratios as well as smart refrigerant leak alert that can indicate significant loss of refrigerant at any point of the system.

For further energy savings, 30KAV can be monitored remotely by Carrier experts for energy consumption diagnosis and optimization.

The 30KAV/30KAVP range is available in 5 efficiency levels.

- 30KAV standard unit
 

The AquaForce™ 30KAV is equipped with variable-speed screw compressor and variable-speed fans with AC motors. The 30KAV is optimised to meet the most demanding technical and economic requirements while offering high seasonal energy efficiency levels.  
(Average SEER of 5.17, average EER of 3.0)
- 30KAV with EC fans (option 17)
 

The 30KAV with EC fans option enhances the seasonal energy efficiency and offers state of the art EC fan technology as standard.  
(Average SEER of 5.23, average EER of 3.0)
- 30KAV with High Energy Efficiency (option 119)
 

The 30KAV with High Energy Efficiency option is equipped with variable-speed fans with AC motor and additional heat exchange surface to deliver optimum performance at both full load and part load.  
(Average SEER of 5.35, average EER of 3.4)
- 30KAV with High Energy Efficiency+ (option 119+)
 

The 30KAV with High Energy Efficiency+ option is equipped with EC fans and additional heat exchange surface to provide the highest possible seasonal energy efficiency.  
(Average SEER of 5.45, average EER of 3.4)
- 30KAVP Premium Energy Efficiency.
 

The 30KAVP is based on 30KAV with option 119+. In addition, variable speed screw compressor is equipped with a premium permanent magnet motor. This is a synchronous motor without any slip and rotor losses.  
(Average SEER of 5.6, average EER of 3.5)

### SEER of the 30KAV/30KAVP range

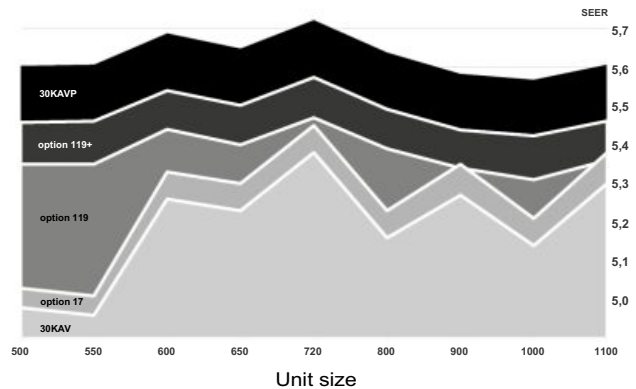

### Outstanding energy performance

- The 30KAV with “High energy efficiency+” is designed for very high performance both at full and part load: average SEER 5.45, average EER 3.4 as per EN14825 & EN14511.
- The 30KAVP with “Premium energy efficiency” is designed for very high performance both at full and part load: average SEER 5.6, average EER 3.5 as per EN14825 & EN14511.
- The high energy efficiency is achieved through:
  - 2<sup>nd</sup> generation of Carrier high-efficiency variable-speed twin-screw compressors with built in volume index control (Vi) valve for both optimal full and part load performance
  - Variable-speed Flying Bird™ fans with EC motor minimising power consumption while delivering optimum air flow
  - Novation™ aluminum condenser with high-efficiency micro-channel coils technology
  - New Carrier flooded shell-and-tube evaporator with new copper tubes for low pressure drops
  - Electronic expansion device permitting operation at a lower condensing pressure and improved utilisation of the evaporator heat exchange surface (superheat control)
  - Economiser system with electronic expansion device for increased cooling capacity.
- Optimised electrical performance:
  - Negligible start-up current (value is lower than the maximum unit current draw)
  - High displacement power factor (above 0.98)
  - EMC compliance with Class 3 requirements of the EU standard EN61800-3 (Class 2 is possible as an option).
- Hydraulic module with variable-speed dual pump
  - Variable-speed, dual pumps which automatically adjust the water flow to match the needs of the building or process load variations.
  - 3 pump control modes available: constant water flow with possibility to reduce the pump speed when there is no cooling demand, variable water flow with constant delta T or constant delta P control.
- Smart energy monitoring
  - Innovative smart energy monitoring providing users with smart data such as real time electric energy consumption, cooling capacity, and instantaneous and average seasonal energy efficiency ratios (Electricity metering accuracy: +/-5%. Cooling capacity metering accuracy: +/-5% at nominal rated conditions).
  - For further energy savings, 30KAV can be monitored remotely by Carrier experts for energy consumption diagnosis and optimization.

## CUSTOMER BENEFITS

### Built-in reliability and easy servicing

The 30KAV/30KAVP units offer enhanced performances as well as Carrier's acclaimed product quality and reliability. Major components were chosen, selected and tested to minimise the possibility of failure.

- 2<sup>nd</sup> generation of variable-speed twin-screw compressors:
  - The screw compressors are industrial-type with oversized bearings and motor cooled by suction gas, with a proven failure rate lower than 0.1%.
  - 30KAVP is fitted with a Permanent Magnet (PM) motor to run the variable screw compressor.
  - Motor is synchronous and spins at supplied frequency, without any slip and rotor losses to induce magnetic field. There is a benefit of +1% in full load efficiency and of +4% in part load efficiency compared to induction motors.
  - Air-cooled compressor variable-speed drive (VSD) to ensure reliable operation and easy maintenance. (Glycol-cooled variable-speed drive (VSD) types are subject to higher failure rates due to glycol pump issue. Refrigerant-cooled variable-speed drive (VSD) types are subject to higher compressor vibration levels causing possible failures in the long term).
  - Compressor bearing life exceeding 100 000 hours
  - All components related to the compressor assembly are easily accessible on site minimising down-time.

- Variable-speed fans:

30KAV is fitted with variable-speed asynchronous fan-motors as standard. One variable-speed drive (VSD) is sized to manage a group of fans per refrigerant circuit reducing first cost while ensuring high part-load efficiency.

30KAV with High Energy Efficiency+ option and 30KAVP is fitted with variable-speed EC fan-motors. Each EC fan is controlled independently ensuring continuous chiller operation in case of motor or drive failure.

- Air-cooled condenser:

- Novation™ aluminum micro-channel heat exchanger (MCHE) with high corrosion resistance. The all aluminum design eliminates the formation of galvanic currents between aluminum and copper that cause coil corrosion in saline or corrosive environments.
- Enviro-shield™ coating for MCHE used in standard and mildly corrosive environments with superior durability confirmed through 5000 hours testing in constant neutral salt spray per ASTM B117 and superior heat transfer performances confirmed through 2000 hours testing per CM1 (Carrier proprietary testing).
- Super Enviro-shield™ coating for MCHE used in highly corrosive environments (industry or marine applications) with superior durability confirmed through 5000 hours testing in constant neutral salt spray per ASTM B117 and superior heat transfer performances confirmed through 2000 hours testing per CM1 (Carrier proprietary testing).

- Evaporator:

- Carrier designed flooded evaporator with mechanically cleanable water tubes
- Electronic paddle-free flow switch to ensure prompt alarm in case of poor liquid flow rate
- Thermal insulation with aluminum sheet finish (option) improved resistance to mechanical and UV damage.

- Refrigerant circuits:

- Two independent refrigerant circuits to secure partial cooling, if one of the two develops a fault.

- Auto-adaptive control:

- Control algorithm prevents excessive compressor cycling (Carrier patent)

- Automatic compressor unloading in case of abnormally high condensing pressure. If condenser coil fouling or fan failure occurs, the Aquaforce continues to operate, but at reduced capacity.

- Exceptional endurance tests:

- To design critical components and sub-assemblies to minimise the risk of failure on site, Carrier uses specialised laboratories and advanced dynamic simulation tools.
- To ensure that the units reach customer sites in the same condition as they are when tested in the factory, Carrier tests the machine behavior while being moved along a 250 km trial. The test-route is based on a military standard and is the equivalent to 5000km by truck in a normal road.
- To ensure coils corrosion resistance, salt mist corrosion resistance test are performed in UTC's laboratory.

In addition, to maintain unit performance throughout its operating life, whilst minimising maintenance costs, end users can access the "Carrier Connect" remote monitoring service.

### Minimised operating sound levels

- The Greenspeed® Intelligence, featuring variable-speed screw compressors and condenser fans, minimises noise levels at part load operation.

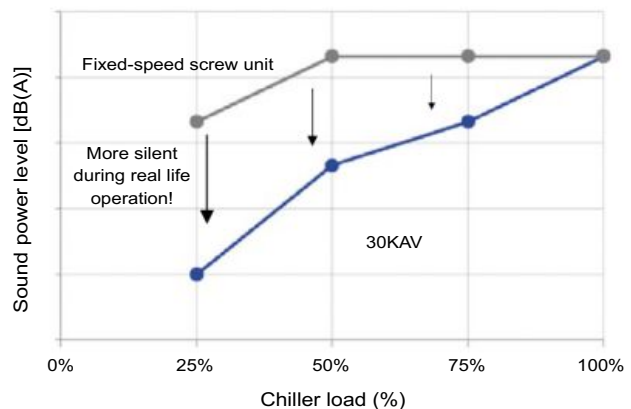

- Standard unit features include:

- The new generation of Carrier 06Z variable-speed twin screw compressor with integrated resonator array to reduce the noise level by 6 dB(A) compared with 06T twin screw compressor previous generation.
- The 6<sup>th</sup> generation of silent Flying Bird™ fans with new fan blade design inspired by nature, help reduce airflow noise.

- 30KAV/30KAVP is available with 4 sound levels to match the most sensitive environments:

- Standard: standard unit configuration with new generation of low sound screw compressor and fans
- Low noise option: addition of high-performance compressor sound enclosure
- Very low noise option: addition of high-performance compressor sound enclosure and fan operation at lower rotational speed.

### Easy and fast installation

- Built-in variable speed pumps up to 800 kW
  - Full hydraulic module with dual pumps (low or high pressure as required) and optional expansion tank
  - Automatic nominal water flow adjustment through electronic control on the user display
- Compact units for easy transportation and installation.
  - Dimensions 25% smaller than the previous 30XAV generation

## CUSTOMER BENEFITS

- Similar dimensions as the old 30GX chillers for easy replacement of the installed base.
- Simplified electrical connections:
  - Main disconnect switch
  - Transformer supply to the integrated control circuit (400/24V)
  - Single electrical point of connection
- Simplified water connections:
  - Victaulic connections on the evaporator
  - Clearly identified entering and practical reference marks for entering and leaving water connections
  - Possibility to choose different evaporator configurations, 1 or 2 passes.
- Fast commissioning:
  - Systematic factory operating test before shipment
  - Functional test for main components, expansion devices, fans and compressors.

### Environmental responsibility

- The AquaForce® Vision 30KAV/30KAVP liquid chillers with Greenspeed® Intelligence is a boost for green cities and contributes to a sustainable future. Combining a reduced charge of R134a refrigerant and exceptional energy efficiency it significantly lowers energy consumption while reducing carbon dioxide emissions by 25% throughout its life cycle (compared to previous fixed-speed screw liquid chiller generation).
- The AquaForce® Vision 30KAV/30KAVP liquid chiller is equipped with an automatic energy meter that provides estimated instantaneous and cumulative cooling energy output, instantaneous and cumulative electric energy consumption, instantaneous and average seasonal energy efficiency ratios (Accuracy: +/- 5% at nominal condition, +/-10% elsewhere) for unit performance monitoring and verification.
- R-134a: HFC refrigerant with zero ozone depletion potential
- 40% less refrigerant charge: The micro-channel technology used for condenser coils optimises heat transfer while minimising the refrigerant volume.
- Leak tight refrigerant circuits:
  - Reduction of leaks as no capillary tubes and flare connections are used
  - Verification of pressure transducers and temperature sensors without transferring refrigerant charge
  - Discharge line shut-off valve and liquid line service valve for simplified maintenance.
- Refrigerant leak alert: The AquaForce® Vision 30KAV/30KAVP liquid chiller is equipped with an automatic refrigerant leak detection algorithm that can detect serious refrigerant loss at any point on the system (Sensitivity: 25% refrigerant charge loss per circuit, depending on the conditions). The automatic refrigerant leak detection system can help to achieve recognition within pollution prevention assessment programs, ideal for assisting in the design of sustainable buildings.
- Refrigerant leak detection: Available as an option, this additional dry-contact allows reporting of possible leaks. The leak detector (by others) should be mounted in the most likely leak location.

### Designed to support Green Building Design

A green building is a building that is environmentally sustainable and has been designed, constructed and is operated to minimise the total impact on the environment.

The resulting building will be economical to operate, offer increased comfort and create a healthier environment for the people who live and work there, increasing productivity.

The air conditioning system can use between 30 and 40% of the annual building energy consumption. Selection of the right air conditioning system is one of the main aspects to consider when designing a green building. For buildings with a variable load throughout the year 30KAV/30KAVP units offer a solution to this important challenge.

A number of green building certification programs exist in the market and offer third-party assessment of green building measures for a wide variety of building types.

The following example looks at how Carrier's new 30KAV/30KAVP range helps customers involved in LEED® building certification.

### Energy saving certificate

30KAV-30KAVP is eligible to Energy savings certificates in France (CEE) in comfort, industrial and agriculture applications:

- Floating High pressure control (by modulating the air flow through fan activation and its speed)
- Floating Low pressure control
- Variable speed on asynchronous compressor motor
- Variable speed on asynchronous fan motor
- Variable speed on asynchronous pump motor

30 KAVP with its PM Motor is also eligible to:

- Variable speed on synchronous compressor motor

For more details about financial incentives in France, please refer to "Fiche produit CEE"

### 30KAV and LEED® certification

The LEED® (Leadership in Energy and Environmental Design) green building certification programme is a preeminent programme to rate the design, construction and operation of green buildings with points assigned in seven credit categories:

- Sustainable Sites (SS)
- Water Efficiency (WE)
- Energy & Atmosphere (EA)
- Materials & Resources (MR)
- Indoor Environmental Quality (IEQ)
- Innovation in Design (ID)
- Regional Priority (RP).

There are a number of different LEED® products.

While the strategies and categories assessed remain same, the point distribution varies to address different building types and application needs, for example according to New Construction, Schools, Core & Shell, Retail and Healthcare.

All programmes now use the same point scale:

### 110 Possible LEED® points

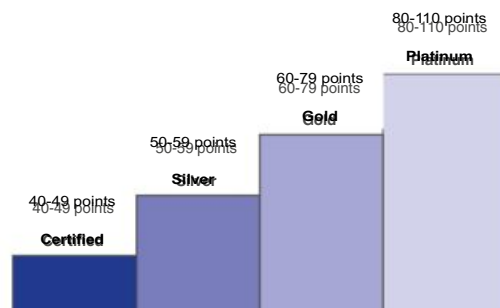

## CUSTOMER BENEFITS

The majority of credits in LEED® rating systems are performance-based and achieving them is dependent on the impacts of each component or sub-system to the overall building.

While the LEED® green building certification programs do not certify products or services, the selection of the right products, systems or service programs is critical to obtain LEED® certification for a registered project, because the right products or service programmes can help meet the goals of green construction and ongoing operation and maintenance.

The choice of heating, ventilating and air conditioning (HVAC) products in particular can have a significant impact on LEED® certification, as the HVAC system directly impacts two categories that together influence 40% of the available points

### Overview of LEED® for new construction and major renovations

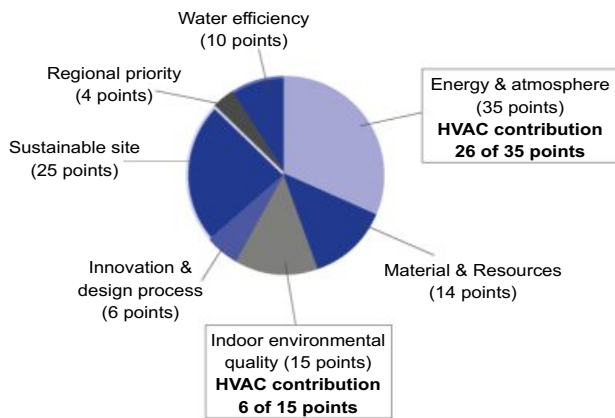

The new 30KAV/30KAVP units from Carrier can assist building owners to earn LEED® points in particular in the Energy & Atmosphere (EA) credit category and help address the following prerequisites and credit requirements:

- **EA prerequisite 2: Minimum energy Performance**  
The 30KAV/30KAVP exceeds the energy efficiency requirements of ASHRAE 90,1-2007; therefore it complies with the prerequisite standard.
- **EA prerequisite 3: Fundamental Refrigerant Management**  
The 30KAV/30KAVP does not use chlorofluorocarbon (CFC) refrigerants thus satisfying the prerequisite statement.
- **EA credit 1: Optimise energy performance (1 to 19 points):**  
Points for this credit are assigned depending on the energy cost reduction virtually achievable by the new building, compared to ASHRAE 90,1-2007 reference. The 30KAV/30KAVP, which is designed for high performance especially during part load operation, contributes to reducing the energy consumption of the building and therefore helps in gaining points within this credit. In addition, the Carrier HAP (Hourly Analyses Program) can be used as an energy analyses program complying with the modeling requirements for this credit and produce reports that are easily transferable to LEED® templates.
- **EA credit 4: Enhanced refrigerant management (2 points):**  
With this credit, LEED® awards systems that minimise the Ozone Depletion Potential (ODP) and Global Warming Potential (GWP) of the system. The 30KAV/30KAVP uses a reduced R134a charge and therefore contributes toward satisfying this credit under LEED®.

**NOTE: This section describes the prerequisites and credit requirements in LEED® for New Construction and is directly related to the 30KAV/30KAVP. Other prerequisites and credit requirements are not directly and purely related to the air-conditioning unit itself, but more to the control of the complete HVAC system.**

i-Vu®, Carrier's open control system, has features that can be valuable for:

- EA prerequisite 1: Fundamental commissioning of energy management system
- EA credit 3: Enhanced commissioning (2 points)
- EA credit 5: Measurements and verification (3 points).

**NOTE: Products are not reviewed or certified under LEED®. LEED® credit requirements cover the performance of materials in aggregate, not the performance of individual products or brands. For more information on LEED®, visit [www.usgbc.org](http://www.usgbc.org).**



## 30KAV TECHNICAL INSIGHTS

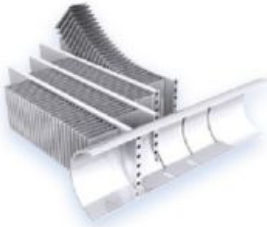

### 3<sup>RD</sup> GENERATION OF “W” SHAPE NOVATION® MICRO CHANNEL HEAT EXCHANGERS

- Exclusive Carrier design
- Increased reliability with new aluminum alloy
- Significantly reduces refrigerant charge (-40% vs cu/al coils)
- More compact units (-25% vs previous 30XAV generation)
- Enviro-shield™ coating for mildly corrosive environments
- Super Enviro-shield™ coating for highly corrosive environments (industry or marine applications)
- Easy cleaning with high pressure air or water washer

### ADVANCED SMARTVU™ WITH 7 INCH COLOR TOUCH SCREEN INTERFACE

- Exclusive Carrier design
- 10 languages available: DE, EN, ES, FR, IT, NL, PT, TR, TU + one additional customer choice
- Touch screen user interface
- BACnet, J-Bus or LON communication interfaces
- Optional wireless connectivity

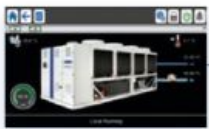

### POWERFUL SMART ENERGY MONITORING FUNCTION

- Provides smart data based on intelligent algorithms
- Real time energy consumption measurement (kWh)
- Cooling energy output measurement (kWh)
- Instantaneous and average Energy Efficiency Ratio under real operating conditions
- Remote monitoring with Carrier Connect

### FLOODED SHELL AND TUBE EVAPORATOR

- Exclusive Carrier design
- Flooded technology for high energy efficiency
- New generation of copper tubes with specific profile to reduce pressure drops when operating with glycol



### 6<sup>TH</sup> GENERATION OF VARIABLE-SPEED FLYING BIRD™ FANS WITH AC OR EC MOTOR

- Exclusive Carrier design
- Fan blade design inspired by nature
- High efficiency version with AC motor technology
- EC motor technology (option)



### VARIABLE-SPEED DUAL PUMPS WITH AC MOTOR

- Dual pumps designed for variable speed operation
- High efficiency AC motor
- Low static pressure (~100 kPa) or high static pressure (~180 Kpa) available
- 3 pump control modes available: constant water flow with 2 speeds, variable water flow based on constant delta T or constant delta P
- Compatibility of chillers for variable primary flow operation



### LATEST GENERATION CARRIER VARIABLE-SPEED 06Z TWIN SCREW COMPRESSOR WITH AC MOTOR

- Exclusive Carrier design
- Twin screw compressor designed for variable speed operation
- High efficiency AC motor
- Stepless variable-speed control (0%-100%)
- Integrated resonator array for compressor acoustic attenuation
- Integrated check valve for quiet shutdown
- Air-cooled inverter drive for increased reliability
- Bearing life exceeding 100.000 hours
- Twin screw compressor with permanent magnet motor as option



## 30KAVP TECHNICAL INSIGHTS



### 3RD GENERATION OF “W” SHAPE NOVATION® MICRO CHANNEL HEAT EXCHANGERS

- Exclusive Carrier design
- Increased reliability with new aluminum alloy
- Significantly reduces refrigerant charge (-40% vs cu/al coils)
- More compact units (-25% vs previous 30XAV generation)
- Enviro-shield™ coating for mildly corrosive environments
- Super Enviro-shield™ coating for highly corrosive environments (industry or marine applications)
- Easy cleaning with high pressure air or water washer
- Extra W module to increase seasonal efficiency

### ADVANCED SMARTVU™ WITH 7 INCH COLOR TOUCH SCREEN INTERFACE

- Exclusive Carrier design
- 10 languages available: DE, EN, ES, FR, IT, NL, PT, TR, TU + one additional customer choice
- Touch screen user interface
- BACnet, J-Bus or LON communication interfaces
- Optional wireless connectivity

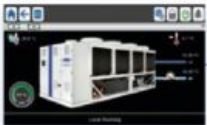

### POWERFUL SMART ENERGY MONITORING FUNCTION

- Provides smart data based on intelligent algorithms
- Real time energy consumption measurement (kWh)
- Cooling energy output measurement (kWh)
- Instantaneous and average Energy Efficiency Ratio under real operating conditions
- Remote monitoring with Carrier Connect

### FLOODED SHELL AND TUBE EVAPORATOR

- Exclusive Carrier design
- Flooded technology for high energy efficiency
- New generation of copper tubes with specific profile to reduce pressure drops when operating with glycol



### 6TH GENERATION OF VARIABLE-SPEED FLYING BIRD™ FANS WITH EC MOTOR

- Exclusive Carrier design
- Fan blade design inspired by nature
- High efficiency version with EC motor



### VARIABLE-SPEED DUAL PUMPS WITH AC MOTOR

- Dual pumps designed for variable speed operation
- High efficiency AC motor
- Low static pressure (~100 kPa) or high static pressure (~180 Kpa) available
- 3 pump control modes available: constant water flow with 2 speeds, variable water flow based on constant delta T or constant delta P
- Compatibility of chillers for variable primary flow operation



### LATEST GENERATION CARRIER VARIABLE-SPEED 06Z TWIN SCREW COMPRESSOR WITH PERMANENT MAGNET MOTOR

- Exclusive Carrier design
- Twin screw compressor designed for variable speed operation
- High efficiency permanent magnet motor
- Stepless variable-speed control (0%-100%)
- Integrated resonator array for compressor acoustic attenuation
- Integrated check valve for quiet shutdown
- Air-cooled inverter drive for increased reliability
- Bearing life exceeding 100.000 hours

## TECHNICAL INSIGHTS

### SmartVu™



- New innovative smart control features:
  - An intuitive and user-friendly, coloured, 7" interface
  - 10 languages available on choice: DE, EN, ES, FR, IT, NL, PT, TR, TU + one additional customer choice
  - Screen-shots with concise and clear information in local languages
  - Complete menu, customised for different users (end user, service personnel and Carrier-factory technicians)
  - Setpoint offset based on the outside air temperature
  - Safe operation and unit setting: Password protection ensures that unauthorised people cannot modify any advanced parameters
  - Simple and "smart" intelligence uses data collection from the constant monitoring of all machine parameters to optimise unit operation
  - Night-mode: Cooling capacity management for reduced noise level.
  - With hydraulic module: Water pressure display and water flow rate calculation.
- Energy management:
  - Innovative smart energy monitoring, providing users with smart data such as real time electric energy consumption, cooling capacity, and instantaneous and average seasonal energy efficiency ratios.
  - Internal time schedule clock controls chiller on/off times and operation at a second set-point
  - The DCT (Data Collection Tool) records the alarms history to simplify and facilitate service operations.
- Maintenance functions
  - F-Gas regulation leak check reminder alert
  - Maintenance alert can be configured to days, months or hours of operation
- Advanced communication features
  - Easy and high-speed communication technology over Ethernet (IP) to a centralised building management system
  - Access to multiple unit parameters.

### Remote management (standard)

- Units with SmartVu™ control can be easily accessed from the internet, using a PC with an Ethernet connection. This makes remote control quick and easy and offers significant advantages for service operations.
- Aquaforce with Greenspeed® Intelligence is equipped with an RS485 serial port that offers multiple remote control, monitoring and diagnostic possibilities. When networked with other Carrier equipment through the CCN (Carrier Comfort Network - proprietary protocol), all components form a HVAC system fully-integrated and balanced through one of the Carrier's network system products, like the Chiller System Manager or the Plant System Manager (optional).

- The 30KAV/30KAVP also communicates with other building management systems via optional communication gateways (BACnet, LON or JBus).
- The following commands/visualisations are possible from remote connection:
  - Start/Stop of the machine
  - Dual set-point management: Through a dedicated contact is possible to activate a second set-point (example, unoccupied mode)
  - Demand limit setting: To limit the maximum chiller capacity to a predefined value
  - Water pump control: These outputs control the contactors of one/two evaporator water pumps.
  - Water pumps changeover (only with hydraulic module options): These contacts are used to detect a water pump operation fault and automatically change over to the other pump.
  - Operation visualisation: Indication if the unit is operating or if it is in stand-by (no cooling load)
  - Alarm visualisation.

### Remote management (EMM option)

- The Energy Management Module (EMM) offers extended remote control possibilities:
  - Room temperature: Permits set-point reset based on the building indoor air temperature (if Carrier thermostats are installed)
  - Set-point reset: Allows reset of the cooling set-point based on a 4-20 mA.
  - Demand limit: Permits limitation of the maximum chiller capacity.
  - Demand limit 1 and 2: Closing of these contacts limits the maximum chiller capacity to two predefined values.
  - User safety: This contact can be used for any customer safety loop; opening the contact generates a specific alarm.
  - Ice storage end: When ice storage has finished, this input permits return to the second set-point (unoccupied mode).
  - Time schedule override: Closing of this contact cancels the programmed time schedule.
  - Out of service: This signal indicates that the chiller is completely out of service.
  - Chiller capacity: This analogue output (0-10 V) gives an immediate indication of the chiller capacity.
  - Alert indication: This volt-free contact indicates the necessity to carry out a maintenance operation or the presence of a minor fault.
  - Compressors running status: Set of outputs (as many as the compressors number) indicating which compressors are running.

## TECHNICAL INSIGHTS

### New generation of Carrier 06Z variable-speed twin screw compressor



The new generation of 06Z variable-speed twin screw compressors benefits from Carrier's long experience in the development of twin-rotor screw compressors. The 06Z compressor design is based on the successful 06T screw compressor, core of the well-known Aquaforce series with a number of modifications to reduce noise level and improve the energy efficiency especially during part load operation.

- New 06Z twin screw compressor optimized for variable speed operation: elimination of the slide valve, built-in volume index control (Vi) valve for both optimal full and part load performance, high efficiency AC motor with stepless inverter control from 20% to 100%.
- 30KAVP screw compressor is equipped with a Permanent Magnet (PM) Motor, which is a four pole motor compared to the two pole induction motor. By the way, the frequency setting doubles with PM motors, but the shaft speed remains the same. There is no slip or rotor losses. Thus, there is a benefit of +1% in full load efficiency and of +4% in part load efficiency.

Permanent Magnet Motor



- Separate air-cooled inverter drive for increased reliability
- New 06Z twin screw compressor design with Integrated Resonator Array (IRA) to reduce the sound level by up to 6 dB(A) when compared with previous 06T generation
- Integrated Check Valve for quiet shutdown
- Bearing life exceeding 100 000 hours.
- A dedicated oil separator is installed at the discharge of each compressor to ensure maximum oil return: Oil separates from refrigerant by gravity and returns to the low pressure side of the compressor without use of additional pumps.
- Volume index control (Vi) valve provides a reliable method of adjusting the compression ratio to better match system demand. It provides optimal performance regardless of operating condition
- Screw compressors work on the positive displacement principle to compress gas to a higher pressure. As a result, if there is an unusually high pressure in the condenser (due for example to coil fouling or operation in harsh climate) the compressor does not switch off, but continues operation at reduced capacity (unloaded mode).
- The silencer in the oil separator line (at the compressor outlet) considerably reduces discharge gas pulsations for much quieter operation.

## TECHNICAL INSIGHTS

### Novation® Heat Exchangers with Microchannel Coil Technology

Already utilised in the automobile and aeronautical industries for many years, the Novation™ Micro-Channel Heat Exchanger (MCHE) used in the Aquaforce is entirely made of aluminum. This one-piece concept significantly increases its corrosion resistance by eliminating the galvanic currents that are created when two different metals (copper and aluminum) come into contact in traditional heat exchangers.

- From the energy efficiency point-of-view the Novation® heat exchangers are approximately 10% more efficient than traditional coils and micro-channel coil technology allows a 40% reduction in the amount of refrigerant used in the chiller.
- The reduced depth of the Novation™ MCHE reduces air pressure losses by 50% and makes it much less susceptible to fouling (e.g. by sand). Cleaning of the Novation™ MCHE heat exchanger is very fast using a high pressure washer.
- To further enhance long-term performance, and protect coils from early deterioration, Carrier offers (as options) dedicated treatments for installations in corrosive environments.
  - The Novation™ MCHE with Enviro-Shield protection (option 262) is recommended for installations in moderately corrosive environments. The Enviro-Shield protection utilises corrosion inhibitors which actively arrest oxidation in case of mechanical damage.
  - The Novation™ MCHE with exclusive Super Enviro-Shield protection (option 263) is recommended for installations in corrosive environments. The Super Enviro-Shield protection consist of an extremely durable and flexible epoxy coating uniformly applied over all coil surfaces for complete isolation from the contaminated environment.
- After a total of more than 7,000 hours of testing following various test standards in UTC laboratories, the Carrier Novation® MCHE with Super Enviro-shield® coating appears to be the best-suited customer choice to minimize the harmful effects of corrosive atmospheres and ensure long equipment life.
  - Best corrosion resistance per ASTM B117/D610 test
  - Best heat transfer performance per Carrier Marine 1 test
  - Proven reliability per ASTM B117 test



Coil Types (ranked by performance)	Visual Corrosion Evaluation	Heat Transfer Performance Degradation	Time to Failure	Test Campaign Conclusions
Super Enviro-shield® Novation™ MCHE	Very good	Good	No coil leak	Best
Super Enviro-shield® Cu/Al coil	Very good	Very good	No coil leak	Very good
Enviro-shield® Novation™ MCHE	Very good	Good	No coil leak	Very good
Al/Al coil	Very good	Good	No coil leak	Very good
Novation™ MCHE	Good	Very good	No coil leak	Good
Cu/Cu coil	Good	Good	Leak	Acceptable
Blygold® Cu/Al coil	Good	Good	No coil leak	Acceptable
Precoat Cu/Al coil	Bad	Bad	No coil leak	Bad
Cu/Al coil	Bad	Bad	No coil leak	Bad



## TECHNICAL INSIGHTS

### New generation of Flying Bird VI fans with EC motors



The 30KAV/30KAVP utilizes Carrier's the 6th generation Flying Bird™ fan technology, engineered for maximum efficiency, super low noise, and wide operating range. The fan includes Carrier patented rotating shroud technology and back-swept blades with a unique wave-serration trailing edge inspired from nature.

It was designed and optimized for the 30KAV/30KAVP air management system configuration and heat exchanger technology. On 30KAVP, and on 30KAV with option 17 and option 119+, fans are propelled by an EC motor, also known as brushless DC, with a unique electronics to manage commutation. This provides a great accuracy for fans that require higher efficiencies and variable speed. The fan meets the latest European eco-design requirements for fan efficiency. The fan uses Carrier's robust and proven injection molded composite-thermoplastic construction.

**EC Motor**





## TECHNICAL INSIGHTS

### Variable Frequency Drives (VFD)

The compressors, the fans and the pumps of 30KAV-30KAVP are controlled by VFDs.

- VFDs electrical box has an IP44 rating as standard and IP54 as an option (available in 2019).
- Electrical box is capable of operating up to 55°C (with option 16 "High Ambient").
- Unit controls is capable of withstanding storage temperatures in the control compartment from -20°C to 68°C.
- All VFDs on the chiller (compressors, fans and pumps motors) are fully air cooled and shall not require an additional glycol cooling system, thus avoiding the maintenance associated with such cooling systems.



Fan drives + Pump drives +  
electronic boards



Compressor drives + main  
power connection

### Actual Major product modification : A

1	2	3	4	5	6	7	8	9	10	11	12	13	14	15	16	17	18
3	0	K	A	V	-	1	0	0	0	A	-	-	-	-	-	-	-

Product codification

- Digit 5: Model series 30KAV
- Digits 6: Efficiency ('P' = Premium version)
- Digits 7 to 10: Number based on the cooling capacity in kW
- Digit 11: Major product modification
- Digit 12 to 14: Counter used to generate a one time product code
- Digit 15: Used for TWO PIECES SHIPMENT '1' = module 1, '2' = module 2 and '-' for single piece
- Digit 16: Country code / P with Montluel 30KAV (European PED pressure vessel approval)
- Digit 17 & 18, always EE (Montluel production)

## OPTIONS

Option	N°	Description	Advantage	Use 30KAV	Use 30KAVP
Medium Brine down to -6°C	5	Redesigned evaporator to allow chilled brine solution production down to -6°C (including different number of tubes in the evaporator, extra insulation, specific sensors and algorithms).	Covers specific applications such as ice storage and industrial processes	0500-1100	0500-1100
Low Brine with turbulators down to -15°C	6	Redesigned evaporator including turbulators to allow chilled brine solution production with low pressure drops on the entire negative application range, down to -15°C (including turbulators, extra insulation and algorithms).	Covers specific applications such as ice storage and industrial processes	0500-1100	0500-1100
Light-brine solution, down to -4°C	8	Implementation of new control algorithms and thermal insulation to allow chilled brine solution production down to -4°C when ethylene glycol is used (-2°C with propylène glycol)	Matches with most application requirements for ground-sourced heat pumps and fits with many industrial processes requirements	0500-1100	0500-1100
Low noise level	15	Aesthetic and sound absorbing compressor enclosure	Noise level reduction	0500-1100	0500-1100
Very low noise level	15LS	Sound absorbing & aesthetic compressor enclosure and oil separator, evaporator and suction line acoustic treatment, combined with low-speed fans	Noise level reduction in sensitive environments	0500-1100	0500-1100
High ambient temperature	16	Electrical components sized for part load operation up to 55°C air ambient	Extended unit part-load operation up to 55°C ambient temperature	0500-1100	0500-1100
EC fans	17	Unit equipped with EC fans	Enhances the unit energy efficiency	0500-1100	-
IP54 control box	20A	Increased leak tightness of the unit	Protects the inside of the electrical box from dust, water and sand. In general this option is recommended for installations in polluted environments	0500-1100	0500-1100
Grilles and enclosure panels	23	Metallic protection grilles and side enclosure panels	Improves aesthetics, protection against intrusion to the unit interior, coil and piping protection against impacts.	0500-1100	0500-1100
Enclosure panels	23A	Side enclosure panels	Improves aesthetics and piping protection against impacts.	0500-1100	0500-1100
Water exchanger frost protection	41A	Electric resistance heater on the water exchanger and discharge valve	Water exchanger frost protection down to -20°C outside temperature	0500-1100	0500-1100
Evaporator & hydraulic module frost protection	41B	Electric resistance heater on water exchanger, discharge valve and hydraulic module	Water exchanger and hydraulic module frost protection down to -20°C outside temperature	0500-0800	0500-0800
Evaporator & recovery condenser frost protection	41C	Electric resistance heater on evaporator exchanger, discharge valve and add heaters and insulation on hydraulic connection (option 325)	Water exchanger module frost protection between 0°C and -20°C outside air temperature	0500-1100	0500-1100
Partial heat recovery	49	Unit equipped with one desuperheater on each refrigerant circuit	Production of free high-temperature hot-water simultaneously with chilled water production (or hot water for Heat pump)	0500-1100	0500-1100
Total heat recovery	50	Unit equipped with additional heat exchanger in series with the condenser coils. (Each exchanger is equipped with heaters and insulation)	Production of free hot-water with variable heat reclaim	0500-1100	0500-1100
Master/slave operation	58	Unit equipped with supplementary water outlet temperature sensor kit (to be field installed) allowing master/slave operation of two units connected in parallel	Optimised operation of two units connected in parrallel operation with operating time equalisation	0500-1100	0500-1100
Main disconnect switch with short-circuit protection	70D	Disconnecter circuit breaker equipped with an external disconnect switch handle	Ensure protection of main disconnect switch and associated cables against short-circuits when building devices are not compliant	0500-1100	0500-1100
Evap. and pumps with aluminum jacket	88A	Evaporator and pumps covered with an aluminum sheet for thermal insulation protection	Improved resistance to aggressive climate conditions	0500-0800	0500-0800

## OPTIONS

Option	N°	Description	Advantage	Use 30KAV	Use 30KAVP
Service valve set	92	Liquid line valve (evaporator inlet) and compressor suction line valve	Allow isolation of various refrigerant circuit components for simplified service and maintenance	0500-1100	0500-1100
Compressor discharge valves	93A	Shut-off valve on the compressor discharge piping	Simplified maintenance	0500-1100	0500-1100
21 bar evaporator	104	Reinforced evaporator for extension of the maximum water-side service pressure to 21 bar (standard 10 bar)	Covers applications with a high water column evaporator side (typically high buildings)	0500-1100	0500-1100
LP VSD dual-pump hydraulic mod.	116A	Dual low-pressure water pump with variable speed drive (VSD), pressure transducers. Multiple possibilities of water flow control. For more details, refer to the dedicated chapter.	Easy and fast installation (plug & play), significant pumping energy cost savings (more than two-thirds), tighter water flow control, improved system reliability	0500-0800	0500-0800
HP VSD dual-pump hydraulic module	116W	Dual high-pressure water pump with variable speed drive (VSD), pressure transducers. Multiple possibilities of water flow control (expansion tank with built-in safety hydraulic components available in option)	Easy and fast installation (plug & play), significant pumping energy cost savings (up to two-thirds), tighter water flow control, improved system reliability	0500-0800	0500-0800
High Energy Efficiency	119	Additional condenser coil to improve unit energy efficiency	Enhances the unit energy efficiency performance	0500-1100	-
High Energy Efficiency+	119+	Additional condenser coil plus EC fans to improve unit energy efficiency	Enhances the unit energy efficiency performance	0500-1100	-
Lon gateway	148D	Bi-directional communication board complying with Lon Talk protocol	Connects the unit by communication bus to a building management system	0500-1100	0500-1100
Bacnet over IP	149	Bi-directional high-speed communication using BACnet protocol over Ethernet network (IP)	Easy and high-speed connection by ethernet line to a building management system. Allows access to multiple unit parameters	0500-1100	0500-1100
Modbus over IP and RS485	149B	Bi-directional high-speed communication using Modbus protocol over Ethernet network (IP)	Easy and high-speed connection by ethernet line to a building management system. Allows access to multiple unit parameters	0500-1100	0500-1100
Energy Management Module	156	EMM Control board with additional inputs/outputs. See Energy Management Module option chapter	Extended remote control capabilities (Set-point reset, ice storage end, demand limits, boiler on/off command...)	0500-1100	0500-1100
Input contact for Refrigerant leak detection	159	0-10 V signal to report any refrigerant leakage in the unit directly on the controller (the leak detector itself must be supplied by the customer)	Immediate customer notification of refrigerant losses to the atmosphere, allowing timely corrective actions	0500-1100	0500-1100
Dual relief valves on 3-way valve	194	Three-way valve upstream of dual relief valves on the shell and tubes evaporator	Valve replacement and inspection facilitated without refrigerant loss. Comforms to European standard EN378/BGVD4	0500-1100	0500-1100
Compliance with Swiss regulations	197	Additional tests on the water heat exchangers: supply (additional of PED documents) supplementary certificates and test certifications	Conformance with Swiss regulations	0500-1100	0500-1100
Compliance with Russian regulations	199	EAC certification	Conformance with Russian regulations	0500-1100	0500-1100
Compliance with Australian regulations	200	Unit approved to Australian code	Conformance with Australian regulations	0500-1100	0500-1100
Insulation of the evap. in/out ref.lines	256	Thermal insulation of the evaporator entering/leaving refrigerant lines with flexible, UV resistant insulation	Prevents condensation on the evaporator entering/leaving refrigerant lines	0500-1100	0500-1100
Enviro-Shield anti-corrosion protection	262	Coating by conversion process which modifies the surface of the aluminum producing a coating that is integral to the coil. Complete immersion in a bath to ensure 100% coverage. Minimal heat transfer variation, tested 4000 hours salt spray per ASTM B117	Improved corrosion resistance, recommended for use in moderately corrosive environments	0500-1100	0500-1100

## OPTIONS

Option	N°	Description	Advantage	Use 30KAV	Use 30KAVP
Super Enviro-Shield anti-corrosion protection	263	Extremely durable and flexible epoxy polymer coating applied on micro channel heat exchangers by electro coating process, final UV protective topcoat. Minimal heat transfer variation, tested 6000 hours constant neutral salt spray per ASTM B117, superior impact resistance per ASTM D2794	Improved corrosion resistance, recommended for use in extremely corrosive environments	0500-1100	0500-1100
Welded evaporator connection (kit)	266	Victaulic piping connections with welded joints	Easy installation	0500-1100	0500-1100
Welded heat recovery condenser connection (kit)	267	Victaulic piping connection with welded joints	Easy installation	0500-1100	0500-1100
Evaporator with aluminum jacket	281	Evaporator covered with an aluminum sheet for thermal insulation protection	Improved resistance to aggressive climate conditions	0500-1100	0500-1100
EMC class. C2, as per EN 61800-3	282	Additional RFI filters on the unit power line	Reduces electromagnetic interferences for compliance with emission level category C2 in order to allow the units to operate in the first environment (so called, residential environment)	0500-1100	0500-1100
230V electrical plug	284	230V AC power supply source provided with plug socket and transformer (180 VA, 0,8 Amps)	Permits connection of a laptop or an electrical device during unit commissioning or servicing	0500-1100	0500-1100
Expansion tank	293	6 bar expansion tank integrated in the hydraulic module (requires hydraulic module option)	Easy and fast installation (plug & play), & Protection of closed water systems from excessive pressure	0500-0800	0500-0800
Electric energy meter	294	Electricity meter . Display of energy consumption, instantaneous (U, V, I) and cumulated (kWh) on the unit user interface datas available on communication bus	Permits the acquisition, (remote) monitoring of energy used.	0500-1100	0500-1100
Fast Capacity Recovery	295	New software algorithms to allow quick restart and fast loading while preserving unit-reliability	Full capacity recovery in approximately 6 minutes after power failure. Matches requirements of typical critical missions applications	0500-1100	0500-1100
Ultra Fast Capacity Recovery	295+	Electrical capacity module to enable quick restart and fast loading preserving unit reliability	Ultra Fast full capacity recovery after power failure. Matches requirements of typical critical missions applications. (process, data centers)	0500-1100	0500-1100
Mexico screw compressor	297	Screw compressor made in Mexico	Mexico screw compressor	0500-1100	-
Connected Services	298A	Transmit the machine's operating data in real time via a 4G LTEM network.	Monitor and control machine status remotely.	0500-1100	0500-1100
Variable Water Flow control	299	hydraulic control function package that permits control of the water flow rate based on different possible logics (at customer choice): constant delta T, constant outlet pressure and "fixed-speed" control	When variable-speed pumps on the primary circuit, the VWF control modulates flow rate through the evaporator, minimising pump consumption while ensuring safe/ optimised chiller operation	0500-1100	0500-1100
Free-cooling dry cooler control	313	Control & connections to a Free Cooling Dry cooler 09PE or 09VE fitted with option FC control box	Easy system management, Extended control capabilities to a dry cooler used in Free Cooling mode	0500-1100	0500-1100
Compliance with UAE regulation	318	Additional label on the unit with rated power input, rated current and EER following AHRI 550/590	Compliance with ESMA standard UAE.S 5010-5:2019.	0500-1100	0500-1100
Compliance with Qatar regulation	319	Specific nameplate on the unit with power supply 415 V+/-6%	Compliance with KAHRAMAA regulation in Qatar.	0500-1100	0500-1100
Hydraulic connection kit	325	Water piping on condenser and evaporator side	Easy installation	0500-1100	0500-1100
Compliance with Morocco regulation	327	Specifics documents according Morocco regulation	Conformance with Morocco regulations	0500-1100	0500-1100
Compressor with permanent magnet	329	Screw compressor equipped with permanent magnet motor	Permanent magnet motor improves significantly compressor efficiency	0500-1100	-
Plastic Tarp	331	Plastic tarp covering units with strapping and campled on the wooden pallet	Allow unit to avoid dust and dirt from the outside environment during stocking and shipping	0500-1100	0500-1100



## PHYSICAL DATA

### Standard units

30KAV		500A	550A	600A	650A	720A	800A	900A	1000A	1100A			
<b>Cooling</b>													
<b>Standard unit</b> Full load performances*	CA1	Nominal capacity	kW		493	537	600	636	723	791	892	975	1079
		EER	kW/kW		2,85	2,80	3,08	2,92	3,12	2,91	3,01	2,84	2,96
<b>Standard unit</b> Seasonal energy efficiency**		SEER <sub>12/7°C</sub> Comfort low temp.	kWh/kWh		4,96	4,90	5,20	5,16	5,31	5,09	5,25	5,09	5,24
		η <sub>s cool</sub> 12/7°C	%		195	193	205	203	209	200	207	200	207
		SEPR <sub>12/7°C</sub> Process high temp.	kWh/kWh		6,16	5,96	6,48	6,32	6,48	6,24	6,34	6,13	6,22
<b>Unit + option 17</b> Seasonal energy efficiency**		SEER <sub>12/7°C</sub> Comfort low temp.	kWh/kWh		5,07	5,01	5,32	5,28	5,43	5,20	5,36	5,20	5,36
		η <sub>s cool</sub> 12/7°C	%		200	197	210	208	214	205	212	205	211
		SEPR <sub>12/7°C</sub> Process high temp.	kWh/kWh		6,29	6,08	6,63	6,46	6,62	6,37	6,48	6,25	6,35
<b>Unit + option 329</b> Seasonal energy efficiency**		SEER <sub>12/7°C</sub> Comfort low temp.	kWh/kWh		5,24	5,16	5,44	5,39	5,51	5,34	5,49	5,34	5,48
		η <sub>s cool</sub> 12/7°C	%		206	203	215	213	218	211	216	211	216
		SEPR <sub>12/7°C</sub> Process high temp.	kWh/kWh		6,38	6,14	6,65	6,47	6,60	6,40	6,49	6,30	6,37
<b>Unit + option 17 + option 329</b> Seasonal energy efficiency**		SEER <sub>12/7°C</sub> Comfort low temp.	kWh/kWh		5,36	5,28	5,58	5,52	5,64	5,47	5,62	5,47	5,61
		η <sub>s cool</sub> 12/7°C	%		211	208	220	218	223	216	222	216	221
		SEPR <sub>12/7°C</sub> Process high temp.	kWh/kWh		6,51	6,27	6,80	6,62	6,76	6,54	6,63	6,43	6,50
<b>Sound levels</b>													
<b>Standard unit</b>													
Sound power <sup>(1)</sup>		dB(A)		95	95	96	98	99	98	99	98	100	
Sound pressure at 10 m <sup>(2)</sup>		dB(A)		63	63	64	65	66	65	67	65	67	
<b>Dimensions</b>													
<b>Standard unit</b>													
Length		mm		4387	4387	5578	5578	6772	6772	7962	7962	9155	
Width		mm		2261	2261	2261	2261	2261	2261	2261	2261	2261	
Height		mm		2324	2324	2324	2324	2324	2324	2324	2324	2324	
<b>Operating weight<sup>(4)</sup></b>													
Standard unit		kg		4691	4700	5067	5077	5519	5951	6367	6813	7199	
<b>Compressors</b>													
<b>Standard unit</b>		06Z twin screw variable speed with AC induction motor and variable frequency drive											
<b>Unit + option 329<sup>(3)</sup></b>		06Z twin screw variable speed with AC permanent magnet motor and variable frequency drive											
Circuit A		Quantity		1	1	1	1	1	1	1	1	1	
Circuit B		Quantity		1	1	1	1	1	1	1	1	1	
Unit minimum part load <sup>(5)</sup>		%		13	13	13	13	13	13	13	12	12	

\* In accordance with standard EN14511-3:2022.  
 \*\* In accordance with standard EN14825:2022, average climate  
 CA1 Cooling mode conditions: Evaporator water entering/leaving temperature 12°C/7°C, outside air temperature 35°C, evaporator fouling factor 0 m<sup>2</sup>.K/W  
**η<sub>s cool</sub> 12/7°C & SEER<sub>12/7°C</sub>** **Bold values compliant to Ecodesign regulation: (EU) No 2016/2281 for Comfort application**  
**SEPR<sub>12/7°C</sub>** **Bold values compliant to Ecodesign regulation: (EU) No 2016/2281 for Process application High Temperature**  
 (1) In dB ref=10<sup>-12</sup> W, 'A' weighted. Declared dual-number noise emission values in accordance with ISO 4871 with an associated uncertainty of +/-3dB(A). Measured in accordance with ISO 9614-1 and certified by Eurovent.  
 (2) In dB ref 20μPa, 'A' weighted. Declared dual-number noise emission values in accordance with ISO 4871 with an associated uncertainty of +/-3dB(A). For information, calculated from the sound power L<sub>w</sub>(A).  
 (3) Options: 17=Fans motors EC type ; 329=Compressors motors PM type  
 (4) Values are guidelines only. Refer to the unit name plate.  
 (5) For standard conditions. Depending on operating conditions, unit might have a different minimum part load or cycle.



Eurovent certified values



## PHYSICAL DATA

### Standard units

30KAV		500A	550A	600A	650A	720A	800A	900A	1000A	1100A	
<b>Refrigerant<sup>(4)</sup> - Standard unit</b>		R134a (GWP=1300 following AR 5, ODP=0)									
Circuit A	kg	49	50	56	59	68	81	91	86	89	
	teqCO <sub>2</sub>	70	72	80	84	97	116	130	123	127	
Circuit B	kg	50	51	57	60	69	61	72	87	90	
	teqCO <sub>2</sub>	72	73	82	86	99	87	103	124	129	
<b>Oil</b>		Oil for R134a. Contact Carrier ERCD for supplying.									
Circuit A	l	27	26	25	23	20	23	20	23	20	
Circuit B	l	27	26	25	23	20	23	20	23	20	
<b>Unit control</b>		SmartVu™ with 7 inch coloured touch screen interface									
Languages		10 languages (DE, EN, ES, FR, IT, NL, PT, TR, TU + one on customer choice)									
Smart energy metering		Standard feature									
Wireless connectivity		Option									
<b>Expansion valve</b>		Electronic expansion valve									
<b>Air heat exchanger</b>		Novation™ Micro Channel Heat Exchanger									
<b>Fans</b>											
<b>Standard unit</b>		Flying Bird™ VI impeller variable speed with AC motor and variable frequency drive									
<b>Unit + option 17<sup>(3)</sup></b>		Flying Bird™ VI impeller variable speed with EC motor									
Quantity		6	6	8	8	10	10	12	12	14	
Maximum total air flow		l/s	35580	35580	47440	47440	59300	59300	71160	71160	83020
Maximum rotation speed		r/s	16,0	16,0	16,0	16,0	16,0	16,0	16,0	16,0	
<b>Water heat exchanger</b>		Flooded shell and tube heat exchanger									
Water volume		l	83	88	96	100	115	126	144	165	183
Max. water-side operating pressure without hydraulic module		kPa	1000	1000	1000	1000	1000	1000	1000	1000	1000
<b>Water connections</b>		Victaulic® type									
<b>Standard unit</b>											
Connections		pouces	5	5	6	6	6	6	8	8	8
Outside tube diameter		mm	141,3	141,3	168,3	168,3	168,3	168,3	219,1	219,1	219,1
<b>Casing paint</b>		Colour code RAL 7035									

(3) Options: 17=Fans motors EC type ; 329=Compressors motors PM type

(4) Values are guidelines only. Refer to the unit name plate.

(5) For standard conditions. Depending on operating conditions, unit might have a different minimum part load or cycle.

## PHYSICAL DATA

### Standard units - option 15&15LS

30KAV		500A	550A	600A	650A	720A	800A	900A	1000A	1100A
<b>Sound levels</b>										
<b>Unit + option 15</b>										
Sound power <sup>(1)</sup>	dB(A)	94	94	94	96	97	96	97	97	98
Sound pressure at 10 m <sup>(2)</sup>	dB(A)	62	62	61	64	64	63	65	64	65
<b>Unit + option 15LS</b>										
Sound power <sup>(1)</sup>	dB(A)	90	90	90	92	94	92	94	93	65
Sound pressure at 10 m <sup>(2)</sup>	dB(A)	57	58	58	59	61	60	62	60	61
<b>Fans</b>										
Quantity		6	6	8	8	10	10	12	12	14
Maximum total air flow + option 15LS	l/s	28920	26100	41600	43200	56000	50000	67200	57840	72800
Maximum rotation speed + option 15LS	r/s	13,2	12,0	14,2	14,7	15,2	13,7	15,2	13,2	14,2

- (1) In dB ref=10<sup>-12</sup> W, 'A' weighted. Declared dual-number noise emission values in accordance with ISO 4871 with an associated uncertainty of +/-3dB(A). Measured in accordance with ISO 9614-1 and certified by Eurovent.
- (2) In dB ref 20µPa, 'A' weighted. Declared dual-number noise emission values in accordance with ISO 4871 with an associated uncertainty of +/-3dB(A). For information, calculated from the sound power Lw(A).



Eurovent certified values

## PHYSICAL DATA

### Units with High energy Efficiency option (119) and 30KAVP units

30KAV option 119/119+		500A	550A	600A	650A	720A	800A	900A	1000A	1100A			
<b>Cooling</b>													
<b>Unit + option 119 + option 17</b> Full load performances*	CA1	Nominal capacity	kW		514	577	614	663	733	820	909	1012	1099
		EER	kW/kW		3,49	3,41	3,40	3,29	3,38	3,35	3,26	3,28	3,19
		Eurovent class			A	A	A	A	A	A	A	A	A
<b>Unit + option 119</b> Seasonal energy efficiency**		<b>SEER<sub>12/7°C</sub> Comfort low temp.</b>	kWh/kWh		<b>5,24</b>	<b>5,21</b>	<b>5,30</b>	<b>5,28</b>	<b>5,37</b>	<b>5,23</b>	<b>5,27</b>	<b>5,18</b>	<b>5,25</b>
		<b>ηs cool<sub>12/7°C</sub></b>	%		<b>207</b>	<b>205</b>	<b>209</b>	<b>208</b>	<b>212</b>	<b>206</b>	<b>208</b>	<b>204</b>	<b>207</b>
		<b>SEPR<sub>12/7°C</sub> Process high temp.</b>	kWh/kWh		<b>7,16</b>	<b>6,87</b>	<b>6,86</b>	<b>6,67</b>	<b>6,76</b>	<b>6,78</b>	<b>6,58</b>	<b>6,62</b>	<b>6,45</b>
<b>Unit + option 119 +</b> Seasonal energy efficiency**		<b>SEER<sub>12/7°C</sub> Comfort low temp.</b>	kWh/kWh		<b>5,37</b>	<b>5,34</b>	<b>5,43</b>	<b>5,41</b>	<b>5,50</b>	<b>5,36</b>	<b>5,39</b>	<b>5,30</b>	<b>5,37</b>
		<b>ηs cool<sub>12/7°C</sub></b>	%		<b>212</b>	<b>211</b>	<b>214</b>	<b>213</b>	<b>217</b>	<b>211</b>	<b>213</b>	<b>209</b>	<b>212</b>
		<b>SEPR<sub>12/7°C</sub> Process high temp.</b>	kWh/kWh		<b>7,32</b>	<b>7,03</b>	<b>7,02</b>	<b>6,82</b>	<b>6,91</b>	<b>6,92</b>	<b>6,72</b>	<b>6,76</b>	<b>6,58</b>
<b>30KAVP</b>		<b>500A</b>	<b>550A</b>	<b>600A</b>	<b>650A</b>	<b>720A</b>	<b>800A</b>	<b>900A</b>	<b>1000A</b>	<b>1100A</b>			
<b>Standard unit</b> Full load performances*	CA1	Nominal capacity	kW		514	577	614	663	733	820	909	1012	1099
		EER	kW/kW		3,56	3,48	3,47	3,36	3,44	3,42	3,33	3,35	3,25
		Eurovent class			A	A	A	A	A	A	A	A	A
<b>Standard unit</b> Seasonal energy efficiency**		<b>SEER<sub>12/7°C</sub> Comfort low temp.</b>	kWh/kWh		<b>5,68</b>	<b>5,61</b>	<b>5,69</b>	<b>5,65</b>	<b>5,72</b>	<b>5,64</b>	<b>5,58</b>	<b>5,57</b>	<b>5,62</b>
		<b>ηs cool<sub>12/7°C</sub></b>	%		<b>224</b>	<b>221</b>	<b>225</b>	<b>223</b>	<b>226</b>	<b>222</b>	<b>220</b>	<b>220</b>	<b>222</b>
		<b>SEPR<sub>12/7°C</sub> Process high temp.</b>	kWh/kWh		<b>7,58</b>	<b>7,23</b>	<b>7,20</b>	<b>6,97</b>	<b>7,05</b>	<b>7,10</b>	<b>6,87</b>	<b>6,94</b>	<b>6,74</b>
<b>30KAV option 119 &amp; 30KAVP</b>		<b>500A</b>	<b>550A</b>	<b>600A</b>	<b>650A</b>	<b>720A</b>	<b>800A</b>	<b>900A</b>	<b>1000A</b>	<b>1100A</b>			
<b>Sound levels</b>													
<b>30KAV_option_119+ &amp; 30KAVP</b>													
Sound power <sup>(1)</sup>	dB(A)		96	96	97	98	99	98	100	98	100		
Sound pressure at 10 m <sup>(2)</sup>	dB(A)		63	63	64	66	66	65	67	65	67		
<b>Dimensions</b>													
<b>30KAV option 119 &amp; 30KAVP</b>													
Length	mm		6772	6772	6772	6772	7962	9155	9120	10346	10346		
Width	mm		2261	2261	2261	2261	2261	2261	2261	2261	2261		
Height	mm		2324	2324	2324	2324	2324	2324	2324	2324	2324		
<b>Operating weight <sup>(4)</sup></b>													
30KAV option 119+ & 30KAVP	kg		5395	5402	5415	5418	5822	6615	6724	7479	7508		

\* In accordance with standard EN14511-3:2022.  
 \*\* In accordance with standard EN14825:2022, average climate  
 CA1 Cooling mode conditions: Evaporator water entering/leaving temperature 12°C/7°C, outside air temperature 35°C, evaporator frosting factor 0 m<sup>2</sup>.K/W  
 ηs cool<sub>12/7°C</sub> & SEER<sub>12/7°C</sub> **Bold values compliant to Ecodesign regulation: (EU) No 2016/2281 for Comfort application**  
 SEPR<sub>12/7°C</sub> **Bold values compliant to Ecodesign regulation: (EU) No 2016/2281 for Process application High Temperature**  
 (1) In dB ref=10<sup>-12</sup> W, 'A' weighted. Declared dual-number noise emission values in accordance with ISO 4871 with an associated uncertainty of +/-3dB(A). Measured in accordance with ISO 9614-1 and certified by Eurovent.  
 (2) In dB ref 20µPa, 'A' weighted. Declared dual-number noise emission values in accordance with ISO 4871 with an associated uncertainty of +/-3dB(A). For information, calculated from the sound power Lw(A).  
 (3) Options: 17=Fans motors EC type ; 329=Compressors motors PM type  
 (4) Values are guidelines only. Refer to the unit name plate.



Eurovent certified values

## PHYSICAL DATA

### Units with High energy Efficiency option (119) and 30KAVP units

30KAV option 119 & 30KAVP		500A	550A	600A	650A	720A	800A	900A	1000A	1100A
<b>Compressors</b>										
<b>30KAV option 119</b>		06Z twin screw variable speed with AC induction motor and variable frequency drive								
<b>30KAV option 119 + option 329<sup>(3)</sup> &amp; 30KAVP</b>		06Z twin screw variable speed with AC permanent magnet motor and variable frequency drive								
Circuit A	Quantity	1	1	1	1	1	1	1	1	1
Circuit B	Quantity	1	1	1	1	1	1	1	1	1
Unit minimum part load <sup>(5)</sup>	%	13	13	13	13	13	13	13	12	12
<b>Refrigerant <sup>(4)</sup> - 30KAV option 119 &amp; 30KAVP</b>		R134a (GWP=1300 following AR5, ODP=0)								
Circuit A	kg	66	66	63	64	72	93	97	97	98
	teqCO <sub>2</sub>	94	94	90	92	103	133	139	139	140
Circuit B	kg	67	67	63	65	73	73	78	98	99
	teqCO <sub>2</sub>	96	96	90	93	104	104	112	140	142
<b>Oil</b>		Oil for R134a. Contact Carrier ERCD for supplying.								
Circuit A	l	27	26	25	23	20	23	20	23	20
Circuit B	l	27	26	25	23	20	23	20	23	20
<b>Unit control</b>		SmartVu™ with 7 inch colored touch screen interface								
Languages		10 languages (DE, EN, ES, FR, IT, NL, PT, TR, TU + one on customer choice)								
Smart energy metering		Standard feature								
Wireless connectivity		Option								
<b>Expansion valve</b>		Electronic expansion valve								
<b>Air heat exchanger</b>		Novation™ Micro Channel Heat Exchanger								
<b>Fans</b>										
<b>30KAV option 119</b>		Flying Bird™ VI impeller variable speed with AC motor and variable frequency drive								
<b>30KAV option 119 + option 17<sup>(3)</sup> &amp; 30KAVP</b>		Flying Bird™ VI impeller variable speed with EC motor								
Quantity		10	10	10	10	12	14	14	16	16
Maximum total air flow	l/s	59300	59300	59300	59300	71160	83020	83020	94880	94880
Maximum rotation speed	r/s	16,0	16,0	16,0	16,0	16,0	16,0	16,0	16,0	16,0
<b>Water heat exchanger</b>		Flooded shell and tube heat exchanger								
Water volume	l	83	88	96	100	115	126	144	165	183
Max. water-side operating pressure without hydraulic module	kPa	1000	1000	1000	1000	1000	1000	1000	1000	1000
<b>Water connections</b>		Victaulic® type								
<b>Standard unit</b>										
Connections	inch	5	5	6	6	6	6	8	8	8
Outside tube diameter	mm	141,3	141,3	168,3	168,3	168,3	168,3	219,1	219,1	219,1
<b>Casing paint</b>		Colour code RAL 7035								

(3) Options: 17=Fans motors EC type ; 329=Compressors motors PM type

(4) Values are guidelines only. Refer to the unit name plate.

(5) For standard conditions. Depending on operating conditions, unit might have a different minimum part load or cycle.

## PHYSICAL DATA

### Standard units - option 15&15LS

30KAV option 119 & 30KAVP		500A	550A	600A	650A	720A	800A	900A	1000A	1100A
<b>Sound levels</b>										
<b>30KAV_option_119+ &amp; 30KAVP : option 15</b>										
Sound power <sup>(1)</sup>	dB(A)	95	95	94	96	97	96	98	98	98
Sound pressure at 10 m <sup>(2)</sup>	dB(A)	62	62	62	64	64	64	65	65	65
<b>30KAV_option_119+ &amp; 30KAVP : option 15LS</b>										
Sound power <sup>(1)</sup>	dB(A)	90	91	91	92	94	92	94	93	65
Sound pressure at 10 m <sup>(2)</sup>	dB(A)	57	58	58	59	61	60	61	60	61
<b>Fans</b>										
Quantity		10	10	10	10	12	14	14	16	16
Maximum total air flow + option 15LS	l/s	44700	43500	52000	52000	64800	67480	75600	74080	83200
Maximum rotation speed + option 15LS	r/s	12,3	12,0	14,2	14,2	14,7	13,2	14,7	12,7	14,2

(1) In dB ref=10<sup>-12</sup> W, 'A' weighted. Declared dual-number noise emission values in accordance with ISO 4871 with an associated uncertainty of +/-3dB(A). Measured in accordance with ISO 9614-1 and certified by Eurovent.

(2) In dB ref 20µPa, 'A' weighted. Declared dual-number noise emission values in accordance with ISO 4871 with an associated uncertainty of +/-3dB(A). For information, calculated from the sound power Lw(A).



Eurovent certified values



## ELECTRICAL DATA

### Electrical data - Standard units

30KAV		500A	550A	600A	650A	720A	800A	900A	1000A	1100A
<b>Power circuit supply</b>										
Nominal voltage	V-ph-Hz	400-3-50								
Voltage range	V	360-440								
<b>Control circuit supply</b>										
24 V via internal transformer										
<b>Maximum operating input power<sup>(1)</sup></b>										
Standard unit	kW	225	246	272	296	320	367	402	451	484
<b>Power factor at maximum power<sup>(1) (2)</sup></b>										
0,91-0,93										
Displacement Power Factor (Cos Phi)										
>0,98										
Total harmonic distortion (THDi) <sup>(1) (3)</sup>										
% 35-45%										
<b>Maximum operating current draw (Un)<sup>(1)</sup></b>										
Standard unit	A	350	382	423	460	498	570	625	701	752
<b>Maximum operating current draw (Un-10%)<sup>(1)</sup></b>										
Standard unit	A	383	416	463	490	530	618	666	747	801
<b>Start-up current<sup>(4)</sup></b>										
Standard unit	A	212	228	245	262	286	378	412	399	425

(1) Values obtained at operation with maximum operating power input (data given on the unit nameplate)

(2) Value decreases when load lowers

(3) May vary according to the installation's short circuit ratio

THDi increases when load lowers. But the highest impact on the installation occurs when the current is maximum. Therefore compliance of the installation regarding voltage harmonic distortion at PCC (per IEC61000-2-4 or other standard) shall be usually checked at max load in order to cover all load conditions.»

(4) Operating current of the biggest compressor + fan current + starting current of the smallest compressor.

Starting current values used for the compressor are : 06ZCE1-H3AA06013 = 40A ; 06ZFC2-3AA06013 = 50A ; 06ZJG3-3AA06013 = 80A.

### Electrical data - Units + option 16

30KAV option 119 & 30KAVP		500A	550A	600A	650A	720A	800A	900A	1000A	1100A
<b>Maximum operating input power<sup>(1)</sup></b>										
Unit + option 16	kW	239	260	288	313	340	390	430	481	519
<b>Maximum operating current draw (Un)<sup>(1)</sup></b>										
Unit + option 16	A	371	404	448	487	529	606	668	747	807
<b>Maximum operating current draw (Un-10%)<sup>(1)</sup></b>										
Unit + option 16	A	406	441	490	519	563	658	711	796	859

(1) Values obtained at operation with maximum operating power input (data given on the unit nameplate)

## ELECTRICAL DATA

### Electrical data - Units with combination of options High energy efficiency (119), PM motor (329), EC motor (17)

30KAV options 119 & 329		500A	550A	600A	650A	720A	800A	900A	1000A	1100A
<b>Power circuit supply</b>										
Nominal voltage	V-ph-Hz	400-3-50								
Voltage range	V	360-440								
<b>Control circuit supply</b>										
24 V via internal transformer										
<b>Maximum operating input power<sup>(1)</sup></b>										
Unit + option 119	kW	224	249	264	286	310	359	388	439	467
Unit + option 119 + option 17	kW	222	247	261	283	307	356	384	435	462
Unit + option 329	kW	220	241	256	279	314	350	395	436	476
Unit + option 329 + option 119	kW	219	244	248	269	304	342	381	424	459
<b>Power factor at maximum power<sup>(1) (2)</sup></b>										
0,91-0,93										
<b>Displacement Power Factor (Cos Phi)</b>										
>0,98										
<b>Total harmonic distortion (THDi)<sup>(1) (3)</sup></b>										
%										
35-45%										
<b>Maximum operating current draw (Un)<sup>(1)</sup></b>										
Unit + option 119	A	348	386	411	445	482	558	603	683	725
Unit + option 119 + option 17	A	345	383	407	441	477	553	597	677	718
Unit + option 329	A	343	375	398	433	488	544	614	678	739
Unit + option 329 + option 119	A	341	379	386	418	472	532	592	660	712
<b>Maximum operating current draw (Un-10%)</b>										
Unit + option 119	A	379	411	448	474	512	603	642	726	772
Unit + option 119+	A	376	408	444	470	507	598	636	720	765
Unit + option 329	A	376	409	438	463	520	592	655	724	788
Unit + option 329 + option 119	A	372	404	423	447	502	577	631	703	759
<b>Start-up current<sup>(4)</sup></b>										
Unit + option 119	A	211	230	239	255	278	371	401	390	411
Unit + option 119 + option 17	A	209	229	237	253	275	369	398	387	408
Unit + option 329	A	204	219	220	240	271	353	391	376	400

(1) Values obtained at operation with maximum operating power input (data given on the unit nameplate)

(2) Value decreases when load lowers

(3) May vary according to the installation's short circuit ratio

THDi increases when load lowers. But the highest impact on the installation occurs when the current is maximum. Therefore compliance of the installation regarding voltage harmonic distortion at PCC (per IEC61000-2-4 or other standard) shall be usually checked at max load in order to cover all load conditions.

(4) Operating current of the biggest compressor + fan current + starting current of the smallest compressor.

Starting current values used for the compressor are : 06ZCE1-H3AA06013 = 40A ; 06ZFC2-3AA06013 = 50A ; 06ZJG3-3AA06013 = 80A.

### Electrical data - Units with combination of options High energy efficiency (119), compressor with PM motor (329), fans with EC motor (17) + option 16

30KAV options 119 & 329		500A	550A	600A	650A	720A	800A	900A	1000A	1100A
<b>Maximum operating input power<sup>(1)</sup></b>										
Unit + option 119 + option 16	kW	238	263	280	303	330	382	416	469	502
Unit + option 119 + option 17 + option 16	kW	236	261	277	300	327	379	412	465	497
Unit + option 329 + option 16	kW	234	255	272	296	334	373	423	466	511
Unit + option 329 + option 119 + option 16	kW	233	258	264	286	324	365	409	454	494
<b>Maximum operating current draw (Un)<sup>(1)</sup></b>										
Unit + option 119 + option 16	A	369	408	436	472	513	594	646	729	780
Unit + option 119 + option 17 + option 16	A	366	405	432	468	508	589	640	723	773
Unit + option 329 + option 16	A	364	397	423	460	519	580	657	724	794
Unit + option 329 + option 119 + option 16	A	362	401	411	445	503	568	635	706	767
<b>Maximum operating current draw (Un-10%)<sup>(1)</sup></b>										
Unit + option 119 + option 16	A	402	436	475	503	545	643	687	775	830
Unit + option 119+ + option 16	A	399	433	471	499	540	638	681	769	823
Unit + option 329 + option 16	A	399	434	465	492	553	632	700	773	846
Unit + option 329 + option 119 + option 16	A	395	429	450	476	535	617	676	752	817

(1) Values obtained at operation with maximum operating power input (data given on the unit nameplate)

## ELECTRICAL DATA

### Electrical data - 30KAVP units

30KAVP		500A	550A	600A	650A	720A	800A	900A	1000A	1100A
<b>Power circuit supply</b>										
Nominal voltage	V-ph-Hz	400-3-50								
Voltage range	V	360-440								
<b>Control circuit supply</b>										
24 V via internal transformer										
<b>Maximum operating input power<sup>(1)</sup></b>										
Standard unit	kW	225	246	272	296	320	367	402	451	484
<b>Power factor at maximum power<sup>(1) (2)</sup></b>										
Displacement Power Factor (Cos Phi)										
>0,98										
<b>Total harmonic distortion (THDi)<sup>(1) (3)</sup></b>										
%										
35-45%										
<b>Maximum operating current draw (Un)<sup>(1)</sup></b>										
Standard unit	A	350	382	423	460	498	570	625	701	752
<b>Maximum operating current draw (Un-10%)<sup>(1)</sup></b>										
Standard unit	A	383	416	463	490	530	618	666	747	801
<b>Start-up current<sup>(4)</sup></b>										
Standard unit		212	228	245	262	286	378	412	399	425

(1) Values obtained at operation with maximum operating power input (data given on the unit nameplate)

(2) Value decreases when load lowers

(3) May vary according to the installation's short circuit ratio

THDi increases when load lowers. But the highest impact on the installation occurs when the current is maximum. Therefore compliance of the installation regarding voltage harmonic distortion at PCC (per IEC61000-2-4 or other standard) shall be usually checked at max load in order to cover all load conditions.

(4) Operating current of the biggest compressor + fan current + starting current of the smallest compressor.

Starting current values used for the compressor are : 06ZCE1-H3AA06013 = 40A ; 06ZFC2-3AA06013 = 50A ; 06ZJG3-3AA06013 = 80A.

### Electrical data - 30KAVP units + option 16

30KAVP		500A	550A	600A	650A	720A	800A	900A	1000A	1100A
<b>Maximum operating input power<sup>(1)</sup></b>										
Unit + option 16	kW	239	260	288	313	340	390	430	481	519
<b>Maximum operating current draw (Un)<sup>(1)</sup></b>										
Unit + option 16	A	371	404	448	487	529	606	668	747	807
<b>Maximum operating current draw (Un-10%)<sup>(1)</sup></b>										
Unit + option 16	A	406	441	490	519	563	658	711	796	859

(1) Values obtained at operation with maximum operating power input (data given on the unit nameplate)

### Compressor electrical data

Compressor	I Max (A) <sup>(1)</sup> Standard	I Max (A) <sup>(1)</sup> Option 16	F max (Hz) <sup>(2)</sup>	Inverter type <sup>(3)</sup>
06ZCE1H3AA06013	190	202	82	D3h
06ZCE1T3AA06013	239	254	105	D3h
06ZFC2T3AA06013	364	389	95	D4h
06ZCEAT3AA06013	220	233	103	D3h
06ZFCBT3AA06013	335	357	93	D4h

(1) Maximum compressor operating current draw over the entire range when powered at rated voltage. May be lower depending on the unit size.

(2) Maximum compressor frequency over the entire range. This frequency can be limited to a lower value depending on the unit size.

(3) Mechanical inverter type : defines inverter weight and dimensions.

## ELECTRICAL DATA

### Distribution of compressors per circuit

30KAV	Circuit	500A	550A	600A	650A	720A	800A	900A	1000A	1100A
06ZCE1H3AA06013	A	1	1	-	-	-	-	-	-	-
	B	1	1	-	-	-	-	-	-	-
06ZCE1T3AA06013	A	-	-	1	1	1	-	-	-	-
	B	-	-	1	1	1	1	1	-	-
06ZFC2T3AA06013	A	-	-	-	-	-	1	1	1	1
	B	-	-	-	-	-	-	-	1	1

30KAVP	Circuit	500A	550A	600A	650A	720A	800A	900A	1000A	1100A
06ZCEAT3AA06013	A	1	1	1	1	1	-	-	-	-
	B	1	1	1	1	1	1	1	-	-
06ZFCBT3AA06013	A	-	-	-	-	-	1	1	1	1
	B	-	-	-	-	-	-	-	1	1

### Electrical notes

- The units have a single power connection point located immediately upstream of the main disconnect switch.
- The two electrical cabinets contain:
  - A power supply disconnecting component : disconnect switch or circuit breaker if option 70D was chosen
  - All or part of the equipment protecting the circuits inside the machine from short circuits.<sup>(1)</sup>
  - Variable frequency drives to manage and protect against overload the compressors, fans, and pumps motors,
  - The switching equipment for the heaters and fans for the electrical equipment
  - The control devices.
- Connections to the building installation:  
Electrical installation and all the connections to the network must be carried out in compliance with all standards applicable to the installation location. Generally, the recommendations of the International Electrotechnical Commission document (IEC60364) are accepted as compliance with the requirements of the installation guidelines.  
The units are designed and built to ensure compliance with these guidelines. The European standard EN 60204-1 (corresponds to IEC 60204-1: Machine safety - Electrical equipment of machines - Part 1: General requirements) was specifically taken into account when the electrical equipment was designed.

#### NOTES

- The standard EN60204-1 enables the requirements of the Machinery Directive to be met.
- Annex B of standard EN 60204-1 is intended to define the electrical characteristics used for the operation of the machines. Those described below apply alongside the other information provided in this document:
  - Environment  
The classification of the environment is specified in standard IEC60364:
    - Outdoor installation<sup>(2)</sup>,
    - Ambient temperature range for the standard machine: from -20°C to +44°C (48°C)<sup>(3)</sup>,
    - Ambient temperature range for the machine with option 16: from -20°C to +48°C (55°C)<sup>(3)</sup>,
    - Altitude: up to 1000 m (2000m)<sup>(4)</sup>
    - Presence of solid foreign bodies: Class AE3 (no significant dust present)<sup>(2)</sup>,
    - Presence of water: class AD4 (projection in all directions without pressure)<sup>(2)</sup>
    - Presence of corrosive and polluting substances, class AF1 (negligible),
    - Competence of personnel: BA4 (trained personnel).
  - Compatibility for low-frequency conducted disturbances according to class 2 levels as per IEC61000-2-4 standard:
    - Power supply frequency variation: +1Hz
    - Phase imbalance: 2%
    - Total Voltage Harmonic Distortion (THDV): 8%
    - Rated impulse voltage Uw (IEC60664-1) :
      - Units without option 16 : 4 kV
      - Units with option 16 : 2.5 kV
  - The neutral wire (N) must not be connected directly to the unit (if necessary, use a transformer).

- Overcurrent protection of the power supply conductors is not provided with the unit.
- The factory-fitted disconnect switch is of a type suitable for power interruption in compliance with EN 60947-3 (equivalent to IEC 60947-3).
- The units are designed for connection to TN networks (IEC 60364). In IT networks, the use of filters integrated into the variable frequency drive(s) prevents the machines from fulfilling their intended purpose. In addition, the equipment's short-circuit holding current characteristics have been modified. Provide a local earth, consult competent local organisations to complete the electrical installation.
- Electromagnetic environment: the classification of the electromagnetic environment is described in the standard EN61800-3 (equivalent to IEC 61800-3):
  - Immunity to external interference defined by the second environment<sup>(5)</sup>
  - Interference emission as defined in category C3<sup>(6)</sup>
- The units integrate variable frequency drives which have harmonic currents which are a source of interference. An analysis may be required to verify if this interference exceeds the compatibility limits of the other devices connected to the same power supply network.  
The compatibility levels inside an electrical installation, that must be met at the in-plant coupling point (IPC) to which other loads are connected, are described in standard IEC 61000-2-4.
- Leakage currents: if protection by monitoring the leakage currents is necessary to ensure the safety of the installation, the presence of DC voltage component as well as additional derived currents introduced by the use of variable frequency drive(s) in the unit must be considered. In particular it is recommended that the differential protection devices are :
  - Suitable for protection of DC and AC circuitry
  - Of reinforced immunity protection types and/or set at a threshold value not lower than 150 mA

**NOTE: if particular aspects of an installation require different specifications from those listed above (or which are not listed), always contact your Carrier representative.**

- With the exception of machines equipped with option 70D, a part of the short circuit protection is not provided and must be carried out on the installation, in compliance with the instructions given in this document.
- The required protection level for this class is IP43BW minimum (according to the reference standard IEC 60529). All units are classified as IP44CW, and fulfil this protection condition.
- The values in brackets correspond to operation with degraded thermal performances.
- Above 1000m, the maximum temperature must be reduced by 0.5K for every additional 100m up to 2000m.
- Example of installations included in the first environment: commercial and residential buildings.  
Example of installations included in the second environment: industrial zones, technical premises powered from a dedicated transformer.
- Category C3 is suitable for use in an industrial environment and is not designed for use in a public low-voltage system that supplies residential or commercial locations. As an option, conformity with category C2 permits this type of installation.

**Warning: In a residential or commercial environment, this product may cause radio interference in which case additional mitigation measures could be required.**

## DIMENSIONS/CLEARANCES

### 30KAV 500A & 550A without Hydraulic module

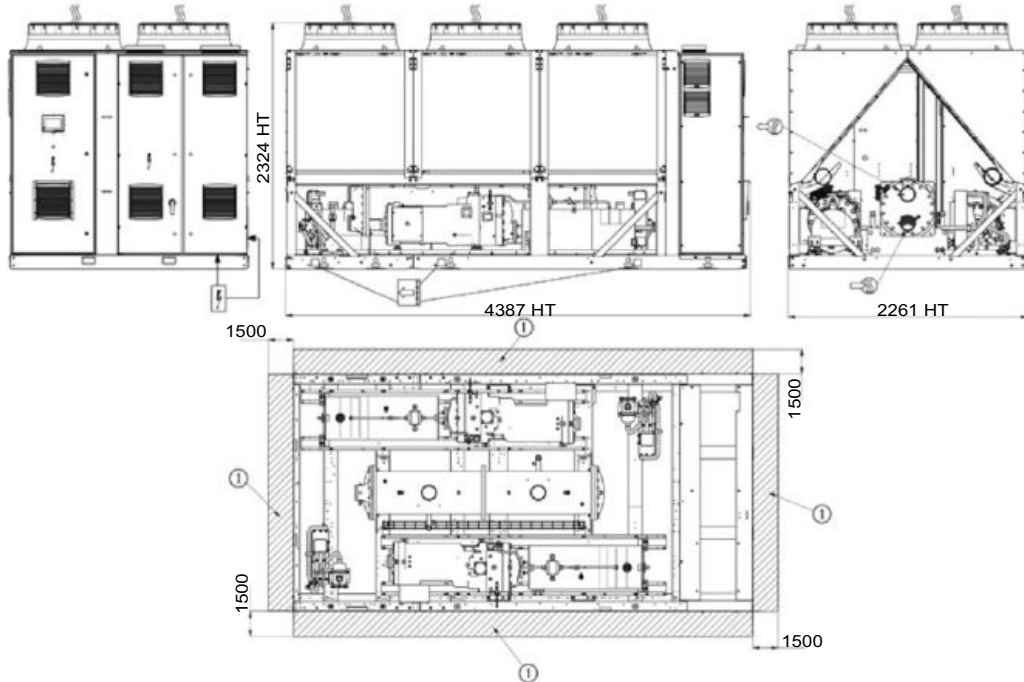

### 30KAV 500A & 550A with Hydraulic module

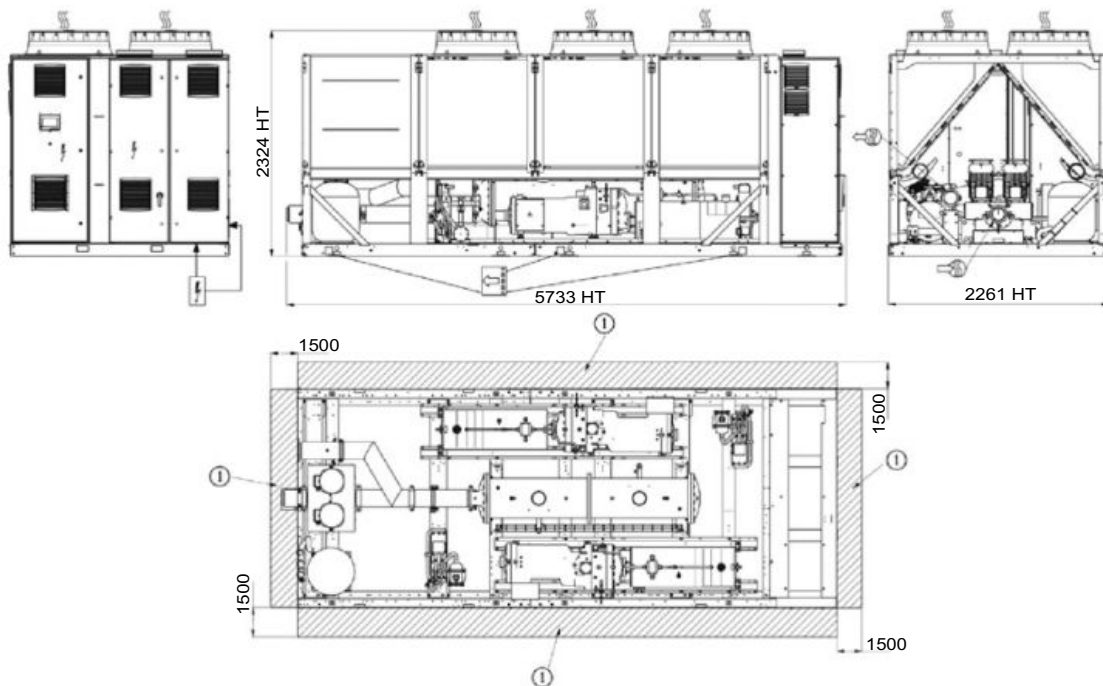

#### Legend

All dimensions are given in mm.

- ① Required clearances for maintenance (see note)
- Water inlet for standard unit
- Water outlet for standard unit
- Air outlet – do not obstruct
- Power electrical connection

#### NOTES:

**Drawings are not contractually binding.**

**Before designing an installation, consult the certified dimensional drawings, available on request.**

**For the positioning of the fixing points, weight distribution and centre of gravity coordinates please refer to the dimensional drawings.**

**If any unit(s) are close to walls, please refer to chapter "Distance to the wall" of this document to determine the space required.**



## DIMENSIONS/CLEARANCES

### 30KAV 600A & 650A without Hydraulic module

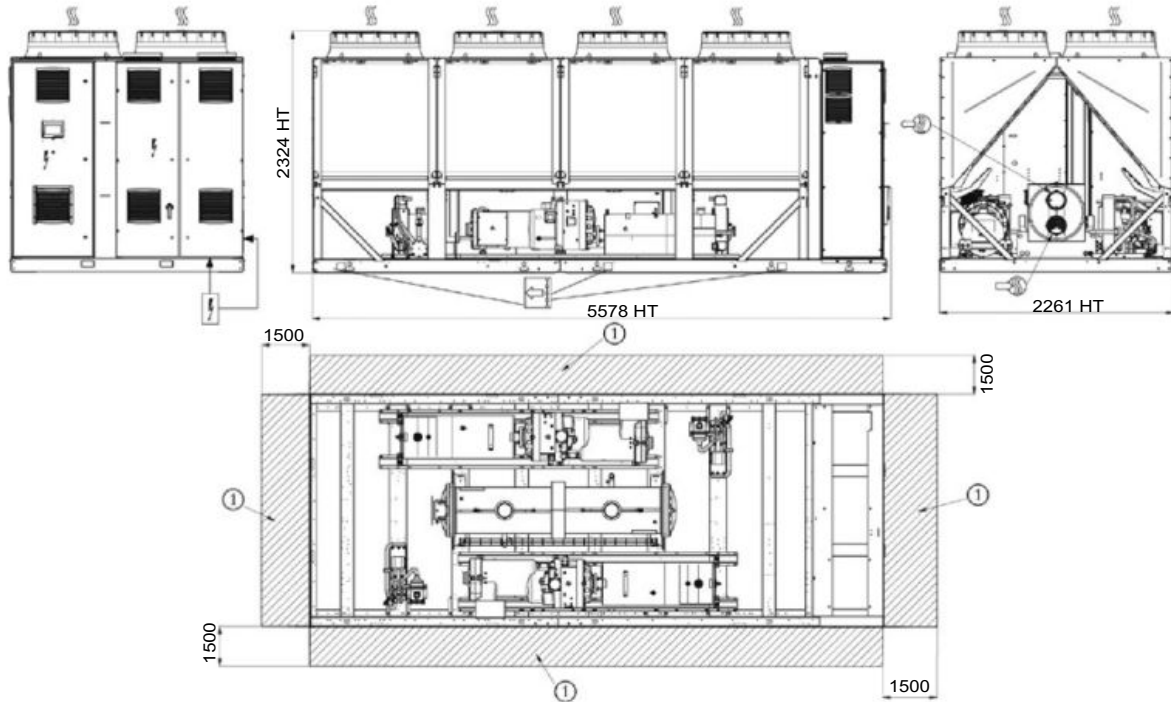

### 30KAV 600A & 650A with Hydraulic module

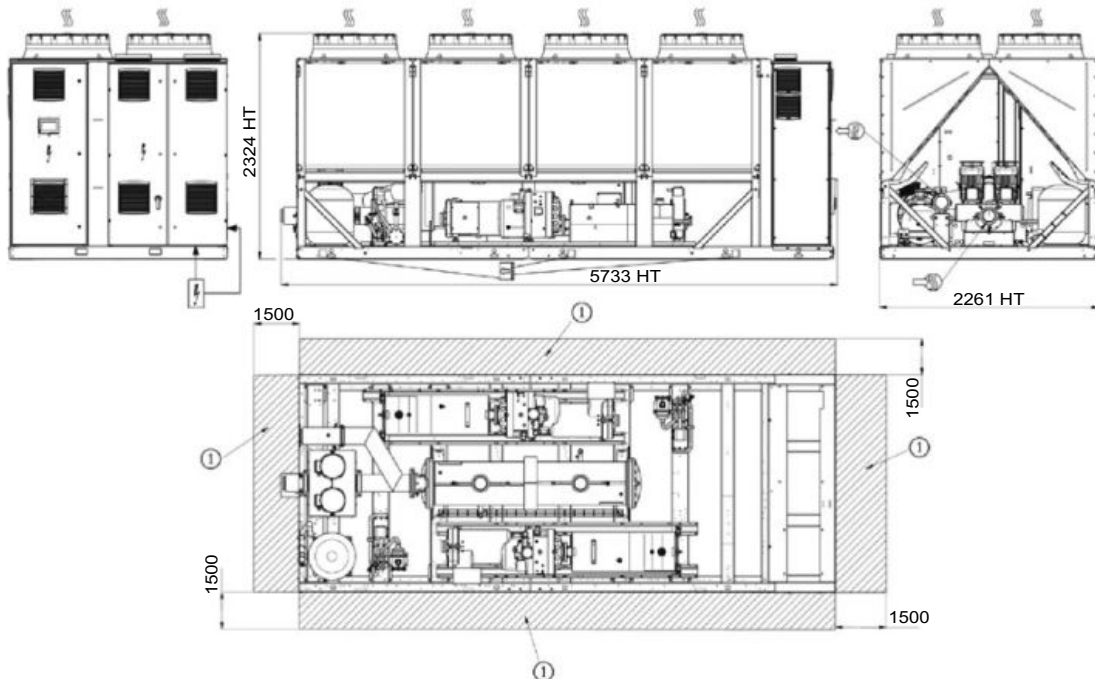

#### Legend

All dimensions are given in mm.

- ① Required clearances for maintenance (see note)
- Water inlet for standard unit
- Water outlet for standard unit
- Air outlet – do not obstruct
- Power electrical connection

#### NOTES:

Drawings are not contractually binding.

**Before designing an installation, consult the certified dimensional drawings, available on request.**

**For the positioning of the fixing points, weight distribution and centre of gravity coordinates please refer to the dimensional drawings.**

**If any unit(s) are close to walls, please refer to chapter "Distance to the wall" of this document to determine the space required.**

## DIMENSIONS/CLEARANCES

30KAV 720A & 800A ; 30KAV 500A, 550A, 600A, 650A - opt 119 ; 30KAVP 500A, 550A, 600A, 650A ; without hydraulic module

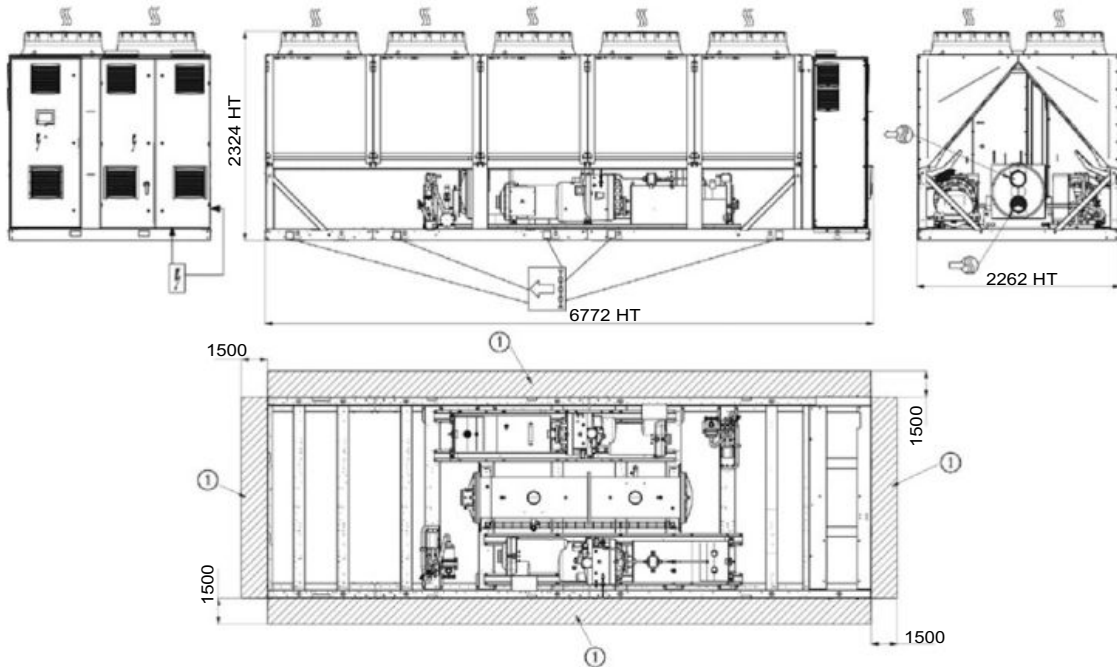

30KAV 720A & 800A ; 30KAV 500A, 550A, 600A, 650A - opt 119 ; 30KAVP 500A, 550A, 600A, 650A ; with hydraulic module

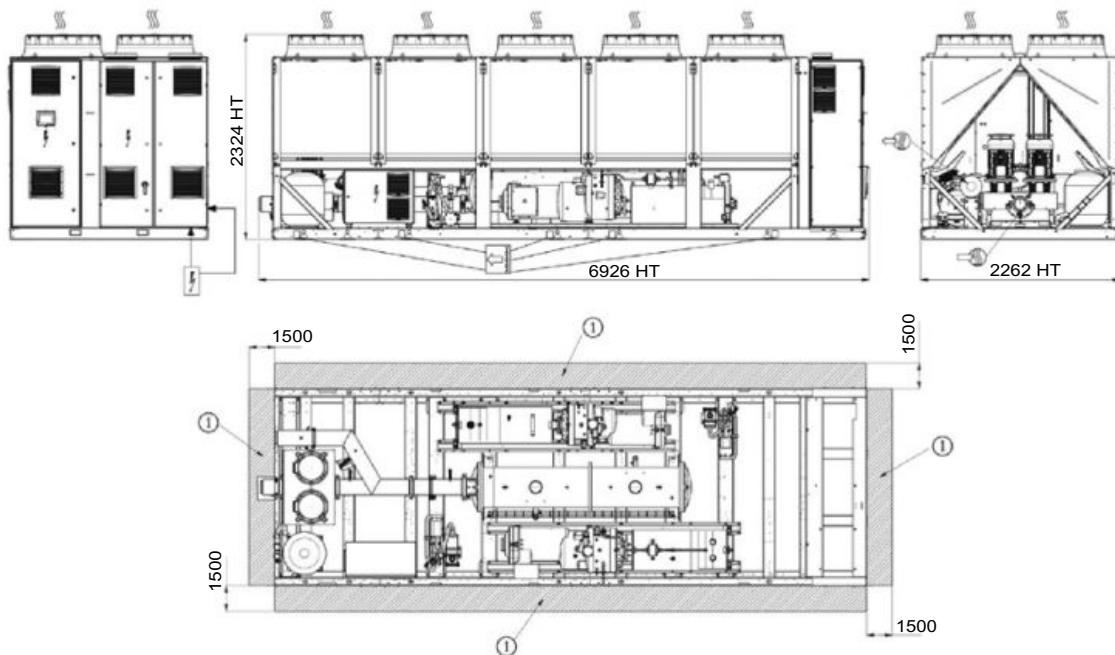

### Legend

All dimensions are given in mm.

① Required clearances for maintenance (see note)

Water inlet for standard unit

Water outlet for standard unit

Air outlet – do not obstruct

Power electrical connection

### NOTES:

Drawings are not contractually binding.

Before designing an installation, consult the certified dimensional drawings, available on request.

For the positioning of the fixing points, weight distribution and centre of gravity coordinates please refer to the dimensional drawings.

If any unit(s) are close to walls, please refer to chapter "Distance to the wall" of this document to determine the space required.

## DIMENSIONS/CLEARANCES

### 30KAV 900A & 1000A ; 30KAV 720A - opt 119 ; 30KAVP 720A ; without hydraulic module

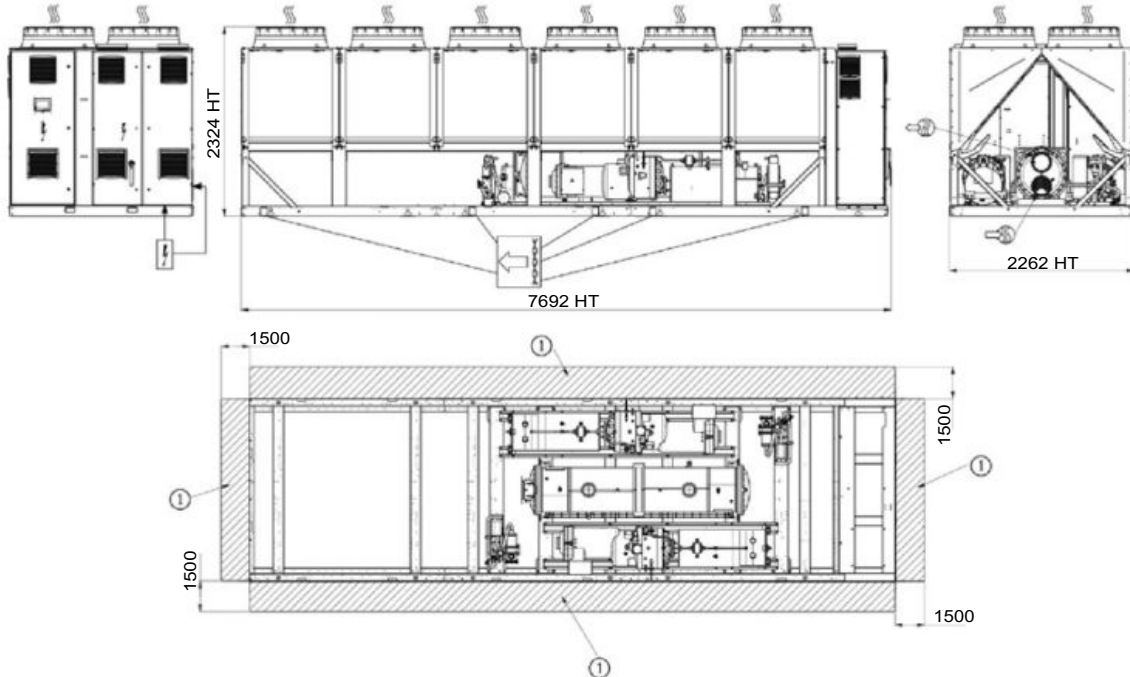

### 30KAV 720A - opt 119 ; 30KAVP 720A ; with hydraulic module

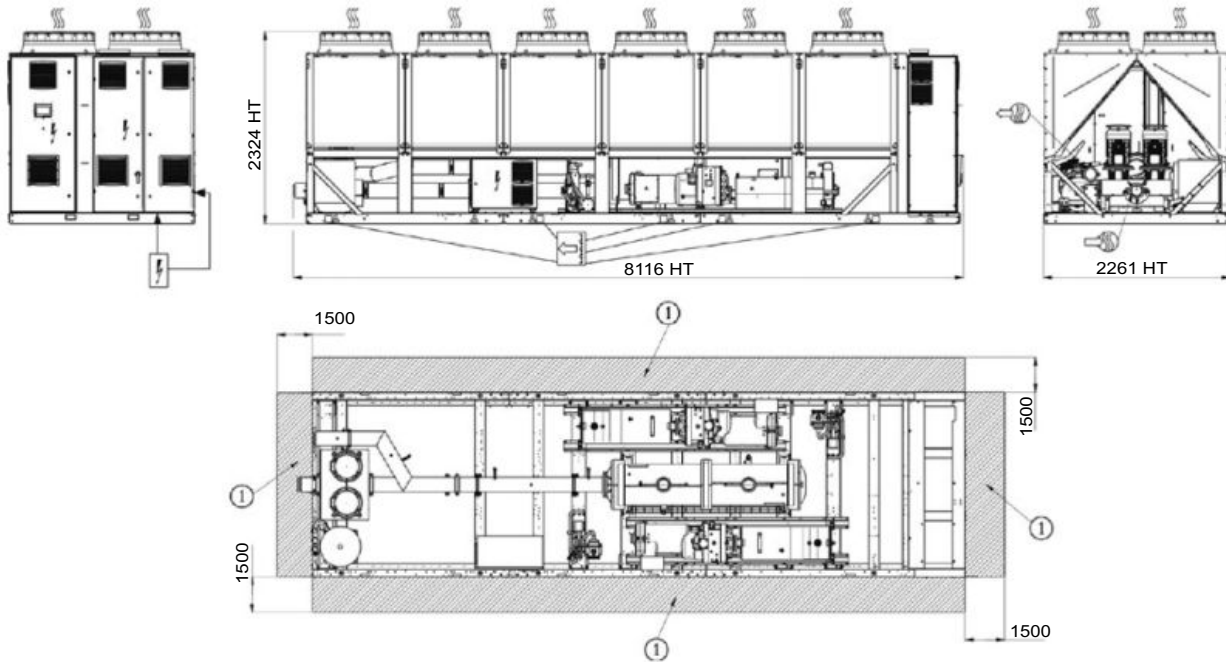

#### Legend

All dimensions are given in mm.

- ① Required clearances for maintenance (see note)
- Water inlet for standard unit
- Water outlet for standard unit
- Air outlet – do not obstruct
- Power electrical connection

#### NOTES:

**Drawings are not contractually binding.**

**Before designing an installation, consult the certified dimensional drawings, available on request.**

**For the positioning of the fixing points, weight distribution and centre of gravity coordinates please refer to the dimensional drawings.**

**If any unit(s) are close to walls, please refer to chapter “Distance to the wall” of this document to determine the space required.**



## DIMENSIONS/CLEARANCES

### 30KAV 1100A ; 30KAV 800A & 900A - opt 119 ; 30KAVP 800A & 900A ; without hydraulic module

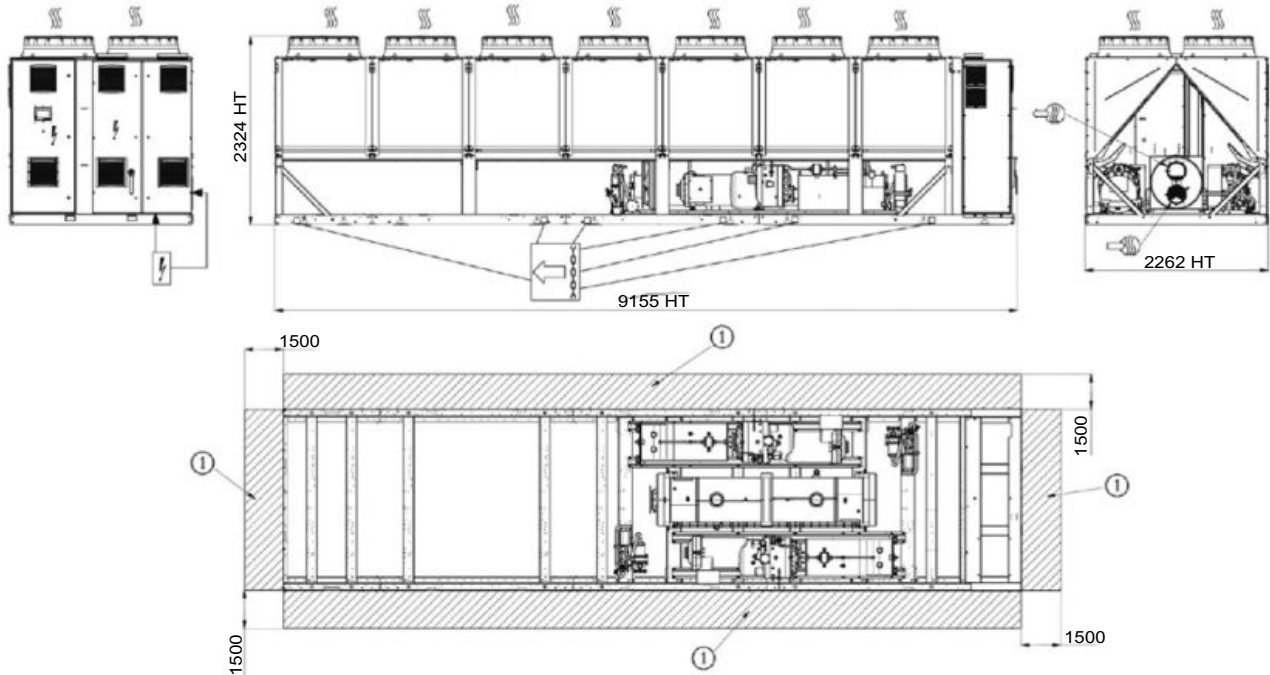

### 30KAV 800A - opt 119 ; 30KAVP 800A ; with hydraulic module

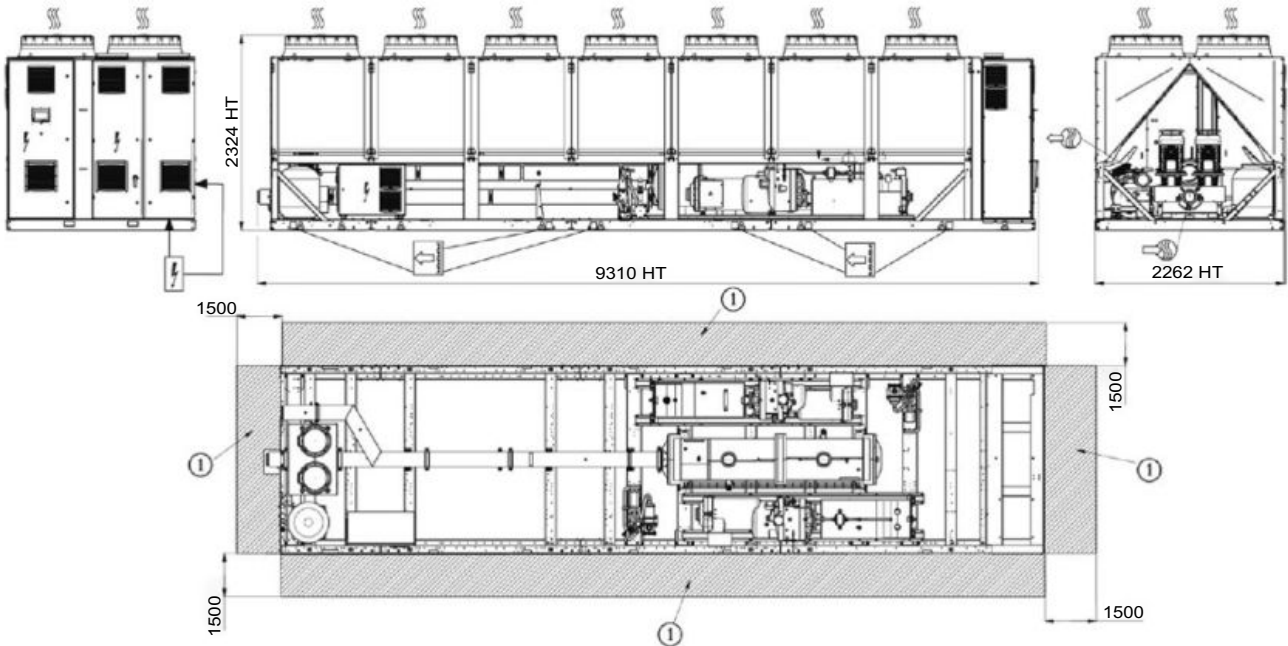

#### Legend

All dimensions are given in mm.

① Required clearances for maintenance (see note)

Water inlet for standard unit

Water outlet for standard unit

Air outlet – do not obstruct

Power electrical connection

#### NOTES:

**Drawings are not contractually binding.**

**Before designing an installation, consult the certified dimensional drawings, available on request.**

**For the positioning of the fixing points, weight distribution and centre of gravity coordinates please refer to the dimensional drawings.**

**If any unit(s) are close to walls, please refer to chapter “Distance to the wall” of this document to determine the space required.**

## DIMENSIONS/CLEARANCES

### 30KAV 1000A & 1100A - opt 119 ; 30KAVP 1000A & 1100A

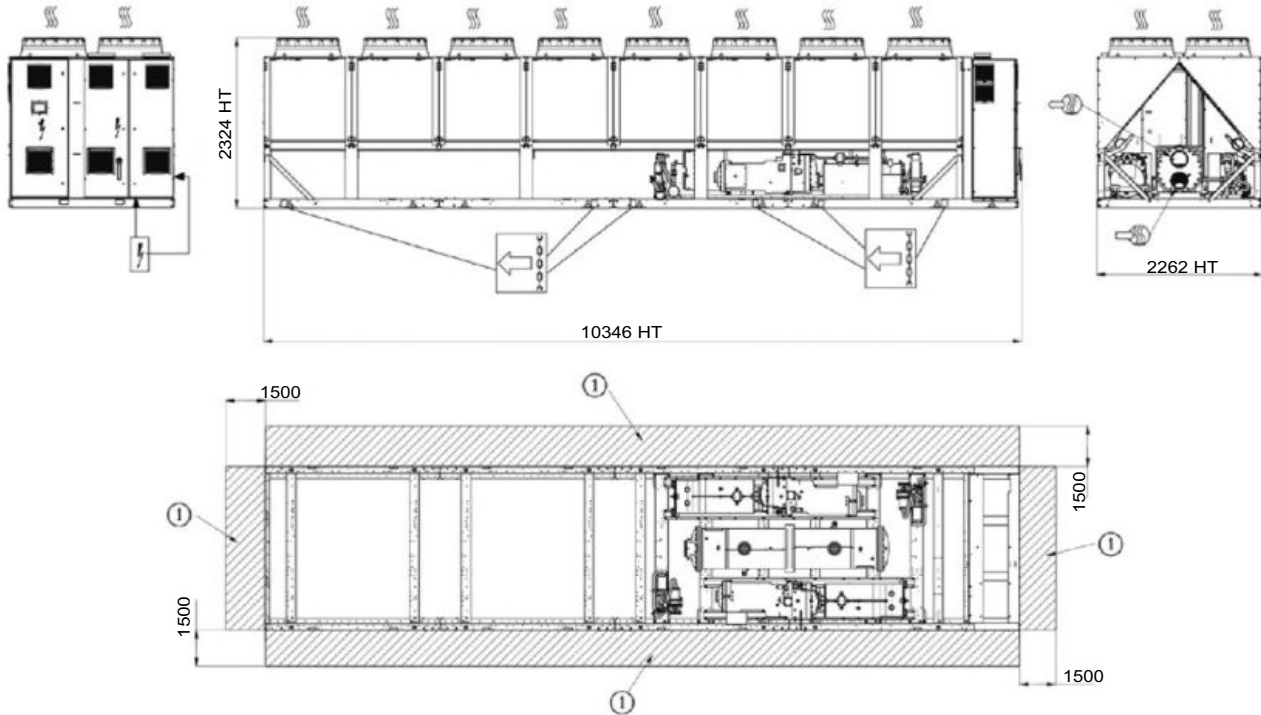

#### Legend

All dimensions are given in mm.

- ① Required clearances for maintenance (see note)
- Water inlet for standard unit
- Water outlet for standard unit
- Air outlet – do not obstruct
- Power electrical connection

### Multiple chiller installation

It is recommended to install multiple chillers in a single row, arranged as shown in the example below, to avoid recycling of warm air from one unit to another.



If the situation at the site does not permit this arrangement, contact your Carrier distributor to evaluate the various possible arrangements. In certain situations an accessory (supplied loose at the time of purchase) can be added.

#### NOTES:

**Drawings are not contractually binding.**

**Before designing an installation, consult the certified dimensional drawings, available on request.**

**For the positioning of the fixing points, weight distribution and centre of gravity coordinates please refer to the dimensional drawings.**

**If any unit(s) are close to walls, please refer to chapter "Distance to the wall" of this document to determine the space required.**

### Distance to the wall

To ensure correct operation for most cases:

- If  $h < H$  (2,3 m),  $S$  minimum = 3 m
- If  $h > H$  ou  $S < 3$  m, contact your Carrier distributor to evaluate the various possible arrangements. In certain situations an accessory (supplied loose at the time of purchase) can be added.

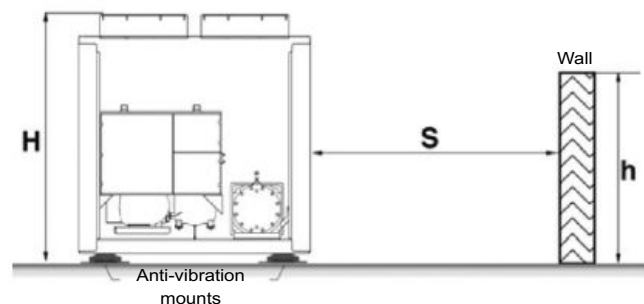





## VARIABLE-SPEED SCREW LIQUID CHILLER WITH GREENSPEED® INTELLIGENCE



- Outstanding performance
- Low sound levels
- Intelligence and connectivity
- Environmental responsibility
- Wide range of applications
- Simple installation and maintenance

30KAV-ZE 350A - 1300A  
 30KAVPZE 350A - 800A  
 30KAVIZE 500 - 1250



Nominal cooling capacity 30KAV-ZE-A : 372 - 1344 kW  
 Nominal cooling capacity 30KAVPZE-A : 380 - 836 kW  
 Nominal cooling capacity 30KAVIZE- : 532 - 1307 kW

The AquaForce® Vision with Greenspeed® intelligence and PUREtec™ refrigerant is the premium solution with variable speed screw compressor and with ultra-low GWP R-1234ze refrigerant for commercial and industrial applications where installers, consultants and building owners require superior reliability and optimal energy performances, especially at part load.

All units are designed to exceed European Ecodesign directive requirements in terms of energy efficiency, versatility and operating sound levels. This result is achieved through the optimised combination of proven best-in-class technologies that include:

- Refrigerant R-1234ze.
- 2<sup>nd</sup> generation of high-efficiency variable-speed twin screw compressors with built in volume index control (Vi) valve for optimal full and part load performance and Integrated Resonator Array (IRA) for low sound operation.
- 30KAVIZE is a range dedicated to Industry and eligible to comfort applications.
- 30KAVPZE premium efficiency with a Permanent Magnet technology motor. Motor is synchronous and spins without any slip and rotor losses.
- 6<sup>th</sup> generation of Carrier Flying Bird™ fans with AC or EC motor depending on options.
- Carrier flooded shell-and-tube evaporator with new copper tubes for low pressure drops
- 3<sup>rd</sup> generation of "W" profile Carrier Novation™ microchannel heat exchangers with optional Enviro-Shield coatings.
- Carrier SmartVu™ control with color touch screen user interface that includes 10 languages and new smart energy monitoring function.



CARRIER participates in the ECP programme for LCP-HP  
 Check ongoing validity of certificate:  
[www.eurovent-certification.com](http://www.eurovent-certification.com)

## AQUAFORCE® VISION WITH PURETEC™ REFRIGERANT

### SUSTAINABILITY

PUREtec™: the environmental excellence solution

#### ■ GWP<1\*

Carrier has selected HFO R-1234ze as the best refrigerant to replace HFC R-134a on screw chillers and heat-pumps.

HFO R-1234ze offers a **Global Warming Potential (GWP) index below 1**, similar to that of natural substances (CO<sub>2</sub> GWP=1).

\* According to AR5 from the IPCC (International Panel on Climate change)

#### ■ High efficiency

This excellent efficiency performance in turn means a **lower total carbon footprint**, with a reduction of 10% compared to HFC R-134a and HFC blends such as R-513A.

#### ■ Regulation compliance

Carrier has made the strategic decision to choose a long-term solution for its new chiller and heat-pump ranges using screw compressors: **HFO R-1234ze, with a GWP<1, is not impacted by the F-gas Regulation.**

## AQUAFORCE® VISION THE RIGHT SOLUTION FOR EVERY APPLICATION

Carrier's AquaForce® Vision range is available in three levels of efficiency to perfectly match each customer application and meet the European Ecodesign directive requirements.

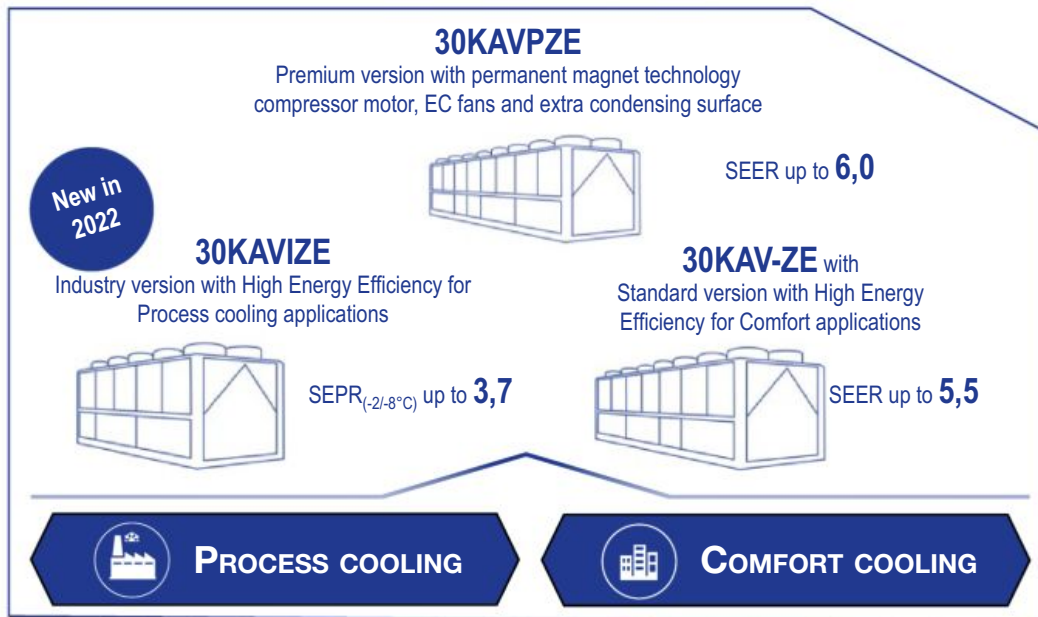

**30KAVIZE**

The AquaForce® 30KAVIZE dedicated to Industry is equipped with variable-speed screw compressor and a reduced condensing surface.

The 30KAVIZE offers an economical solution with a high SEPR level in industrial process cooling. 30KAVIZE is compliant with the 2021 EU Ecodesign SEPR -2/-8°C and 12/7°C requirements for medium and high temperature process chillers.

The 30KAVIZE is also suitable for comfort applications thanks to its reduced dimensions (1/3 smaller than the 30KAV-ZE), and its energy performance that meets the Ecodesign requirements SEER 12/7°C in comfort.



**30KAV-ZE**

The AquaForce® 30KAV-ZE with Greenspeed™ intelligence is equipped with variable speed screw compressor. It offers an economical solution to enhance seasonal energy efficiency levels for comfort applications. The 30KAV-ZE with Greenspeed™ intelligence meets the 2021 EU Ecodesign SEER 12/7°C requirements.



**30KAVPZE**

The AquaForce® 30KAVPZE with Greenspeed™ intelligence is the premium version with permanent magnet technology compressor motor, EC fans and additional heat exchange surface to improve both the full load and part load energy efficiency. The 30KAVPZE provides very cost effective operation in both process and comfort applications through the use of advanced technologies.

## AQUAFORCE® VISION 30KAVIZE CUSTOMER BENEFITS

### ■ Designed for Industry

The 30KAVIZE has been specially developed with an optimised condenser surface for medium process cooling applications down to -12°C with ethylene glycol or down to -10°C with propylene glycol.

The wide operating map of the 30KAVIZE also allows high process cooling temperature, up to +24°C water outlet temperature. The 30KAVIZE range is available with specific options for the industry:

Ultra-Fast Capacity Recovery at Full Power in less than 1 minute.

Low noise and Very low noise options, EC fans, Total heat recovery, Electric Energy Meter, etc.

New options designed specifically for the industry will be added soon:

- Boosted Total Heat Recovery (April 2022)
- Electrical cabinet designed for IT Neutral System (June 2022)
- Synchronous compressor motor with permanent magnet (End 2022)

### ■ High energy performance

Equipped with variable speed screw compressors, fans, 30KAVIZE chiller automatically adjusts the cooling capacity to adapt perfectly to the load variations of the industrial process.

The SEPR is 25% higher than the Ecodesign 2021 requirements.

### ■ Low sound levels

The new generation of Carrier 06Z variable-speed twin screw compressor with integrated resonance attenuator and the 6th generation of Flying Bird™ fans with new fan blade design inspired by nature help to significantly reduce compressor and fan noise. As an option, the 30KAVIZE chiller can be fitted with an acoustic cover for the screw compressor to achieve very low noise levels.

### ■ Intelligence and connectivity

The advanced SmartVu™ intelligent control displays the service parameters in real time, for an intuitive and particularly user-friendly use. The 30KAVIZE range is also characterized by an innovative intelligent energy monitoring function, which provides users with intelligent data such as real-time electrical energy consumption, cooling capacity, as well as instantaneous and average values of the real energy efficiency of the machine. To go further in terms of energy savings, the 30KAVIZE range can be monitored remotely by Carrier experts, in order to carry out a diagnosis and optimize electricity consumption.



SEPR<sub>(-2°C/+8°C)</sub>  
Up to **3,7**



**90 dB(A)**



SMART ENERGY  
MONITORING

### ■ Environmental responsibility

AquaForce® 30KAVIZE uses ultra-low global warming potential (GWP <1) HFO R-1234ze refrigerant. Combining reduced refrigerant charge and exceptional energy efficiency, it significantly lowers energy consumption while reducing CO<sub>2</sub> emissions throughout its life cycle.

### ■ Extensive scope of applications

AquaForce® 30KAVIZE adapts effortlessly to a wide variety of applications. Extended operating temperatures from -20°C to +48°C for air temperatures outdoor, and water temperatures from +24°C to -12°C make it the ideal solution for various applications in industry but also in comfort. AquaForce® 30KAVIZE meets the highest requirements in terms of energy efficiency and energy savings, whatever the climate and geographical location, to meet the needs of the food, chemical, paper, metal, plastic and pharmaceutical industries.

### ■ Easy installation & maintenance

AquaForce® 30KAVIZE offers very compact dimensions, one third less than the 30KAVZE range, facilitating the replacement of machines in tight spaces. AquaForce® 30KAVIZE offers intelligent automatic refrigerant leak detection and continuous energy performance monitoring to facilitate remote maintenance of equipment.



HFO R-1234ze refrigerant with direct CO<sub>2</sub> impact reduced by 99.9% compared to R-134a and 99.8% compared to R-513A



From  
**+24 °C**  
down to **-12 °C**



**1/3**  
SMALLER

## AQUAFORCE® VISION 30KAV(P)ZE CUSTOMER BENEFITS

### ■ Outstanding performance

Equipped with variable-speed screw compressors with permanent magnet motor, EC fans and extra condensing surface, Carrier's AquaForce® Vision 30KAVPZE chiller with Greenspeed™ intelligence automatically adjusts the cooling capacity and the water flow to perfectly match the needs of the building or the process load variations.

The SEER is 25% above 2021 Ecodesign requirements.

### ■ Low sound levels

The new generation of Carrier 06Z variable-speed twin screw compressor with integrated resonator array and the 6th generation of Flying Bird™ fans with new fan blade design inspired by nature help reduce compressor and airflow noise down to as little as 90 dB(A). This range is 6 dB(A) quieter than the previous AquaForce® 30XAV generation.

### ■ Intelligence and connectivity

The advanced SmartVu™ intelligent control system displays operating parameters in real time, making it intuitive and particularly user-friendly. 30KAV ranges also features innovative smart energy monitoring, providing users with smart data such as real time electric energy consumption, cooling energy output and instantaneous and average seasonal energy efficiency ratios. For further energy savings, 30KAV ranges can be monitored remotely by Carrier experts for energy consumption diagnosis and optimization.



SEER  
up to 6,0\*

\* For 30KAVPZE  
Up to 5,6 for 30KAV-ZE



90 dB(A)



SMART ENERGY  
MONITORING

### ■ Environmentally responsible

Carrier's AquaForce® Vision is a boost for green cities and contributes to a sustainable future. Combining a reduced load refrigerant and exceptional energy efficiency it significantly lowers energy consumption while reducing carbon dioxide emissions by 25% throughout its life cycle.

### ■ Extensive scope of application

Carrier's AquaForce® Vision adapts effortlessly to a wide range of applications. Extended operating temperatures from -20°C to 55°C outdoor air temperatures and negative water temperatures make it ideal for various sectors of activity. From high-end office buildings and hotels to healthcare facilities, data centers and industrial projects, AquaForce® Vision meets the most demanding expectations in terms of energy efficiency and savings, whatever the climate and wherever the location.

### ■ Easy installation & maintenance

Built-in variable-speed pumps up to 600kW, automatic nominal water flow adjustment through electronic control, automatic unit energy performance measurement under real conditions, in units that are 25% smaller than the previous 30XAV generation, all these new features provide peace of mind for installers and service companies alike.



UP TO  
25% LESS  
CO<sub>2</sub> EMISSION



FROM  
-20°C  
to 55°C



25%  
SMALLER



## AQUAFORCE® VISION CUSTOMER BENEFITS

AquaForce® Vision liquid chillers with Greenspeed® Intelligence adapt effortlessly to a wide range of applications. An extended operating range covering ambient temperatures from -20 to 55°C makes it ideal for all areas of activity. From high-end office buildings and hotels to healthcare facilities, data centers and industrial projects, 30KAV ranges meets the most demanding expectations in terms of energy efficiency and savings, whatever the climate and wherever the location.

Furthermore, the advanced SmartVu™ intelligent control system displays operating parameters in real time, making it intuitive and particularly user-friendly. 30KAV ranges also features innovative smart energy monitoring, providing users with smart data such as real time electric energy consumption, cooling capacity, and instantaneous and average seasonal energy efficiency ratios as well as smart refrigerant leak alert that can indicate significant loss of refrigerant at any point of the system.

For further energy savings, AquaForce® Vision can be monitored remotely by Carrier experts for energy consumption diagnosis and optimization.

AquaForce® Vision is available in 5 versions.

- **30KAVIZE is a cost effective dedicated range designed to meet industrial expectations while being eligible to comfort applications**  
(Average SEPR (-2/-8) of 3,6, average SEER of 5,0, average EER of 2.8)
- **30KAV-ZE standard unit**  
30KAV-ZE is equipped with variable-speed screw compressor and variable-speed fans with AC motors. The 30KAV-ZE is optimised to meet the most demanding technical and economic requirements while offering high seasonal energy efficiency levels.  
(Average SEER of 5.2, average EER of 3.1)
- **30KAV-ZE with EC fans (option 17)**  
The 30KAV-ZE with EC fans option enhances the seasonal energy efficiency and offers state of the art EC fan technology as standard.  
(Average SEER of 5.3, average EER of 3.1)
- **30KAV-ZE with High Energy Efficiency (option 119)**  
The 30KAV-ZE with High Energy Efficiency option is equipped with variable-speed fans with AC motor and additional heat exchange surface to deliver optimum performance at both full load and part load.  
(Average SEER of 5.4, average EER of 3.4)
- **30KAV-ZE with High Energy Efficiency+ (option 119+)**  
The 30KAV-ZE with High Energy Efficiency+ option is equipped with EC fans and additional heat exchange surface to provide the highest possible seasonal energy efficiency.  
(Average SEER of 5.5, average EER of 3.4)
- **30KAVPZE Premium Energy Efficiency.**  
The 30KAVPZE is based on 30KAV-ZE with option 119+. In addition, variable speed screw compressor is equipped with a premium permanent magnet motor. This is a synchronous motor without any slip and rotor losses.  
(Average SEER of 5.6, average EER of 3.5)

### Outstanding energy performance

- The 30KAV-ZE with “High energy efficiency+” is designed for very high performance both at full and part load: average SEER 5.5, average EER 3.4 as per EN14825 & EN14511.
- The 30KAVPZE with “Premium energy efficiency” is designed for very high performance both at full and part load: average SEER 5.6, average EER 3.5 as per EN14825 & EN14511.

- The high energy efficiency is achieved through:
  - 2<sup>nd</sup> generation of Carrier high-efficiency variable-speed twin-screw compressors with built in volume index control (Vi) valve for both optimal full and part load performance
  - Variable-speed Flying Bird™ fans with EC motor minimising power consumption while delivering optimum air flow
  - Novation™ aluminum condenser with high-efficiency micro-channel coils technology
  - New Carrier flooded shell-and-tube evaporator with new copper tubes for low pressure drops
  - Electronic expansion device permitting operation at a lower condensing pressure and improved utilisation of the evaporator heat exchange surface (superheat control)
  - Economiser system with electronic expansion device for increased cooling capacity.
- Optimised electrical performance:
  - Negligible start-up current (value is lower than the maximum unit current draw)
  - High displacement power factor (above 0.98)
  - EMC compliance with Class 3 requirements of the EU standard EN61800-3 (Class 2 is possible as an option).
- Hydraulic module with variable-speed dual pump
  - Variable-speed, dual pumps which automatically adjust the water flow to match the needs of the building or process load variations.
  - 3 pump control modes available: constant water flow with possibility to reduce the pump speed when there is no cooling demand, variable water flow with constant delta T or constant delta P control.
- Smart energy monitoring
  - Innovative smart energy monitoring providing users with smart data such as real time electric energy consumption, cooling capacity, and instantaneous and average seasonal energy efficiency ratios (Electricity metering accuracy: +/-5%. Cooling capacity metering accuracy: +/-5% at nominal rated conditions).
  - For further energy savings, 30KAV ranges can be monitored remotely by Carrier experts for energy consumption diagnosis and optimization.

### Built-in reliability and easy servicing

The AquaForce® Vision offer enhanced performances as well as Carrier’s acclaimed product quality and reliability. Major components were chosen, selected and tested to minimise the possibility of failure.

- 2<sup>nd</sup> generation of variable-speed twin-screw compressors:
  - The screw compressors are industrial-type with oversized bearings and motor cooled by suction gas, with a proven failure rate lower than 0.1%.
  - 30KAVPZE is fitted with a Permanent Magnet (PM) motor to run the variable screw compressor.
  - Motor is synchronous and spins at supplied frequency, without any slip and rotor losses to induce magnetic field. There is a benefit of +1% in full load efficiency and of +4% in part load efficiency compared to induction motors.
  - Air-cooled compressor variable-speed drive (VSD) to ensure reliable operation and easy maintenance. (Glycol-cooled variable-speed drive (VSD) types are subject to higher failure rates due to glycol pump issue. Refrigerant-cooled variable-speed drive (VSD) types are subject to higher compressor vibration levels causing possible failures in the long term).
  - Compressor bearing life exceeding 100 000 hours
  - All components related to the compressor assembly are easily accessible on site minimising down-time.

## AQUAFORCE® VISION CUSTOMER BENEFITS

### ■ Variable-speed fans:

30KAV-ZE and 30KAVIZE are fitted with variable-speed asynchronous fan-motors as standard. One variable-speed drive (VSD) is sized to manage a group of fans per refrigerant circuit reducing first cost while ensuring high part-load efficiency.

30KAV-ZE and 30KAVIZE + option 17 and 30KAVPZE are equipped with variable speed EC fan motors. Each EC fan is controlled independently ensuring continuous chiller operation in case of motor or drive failure.

### ■ Air-cooled condenser:

- Novation™ aluminum micro-channel heat exchanger (MCHE) with high corrosion resistance. The all aluminum design eliminates the formation of galvanic currents between aluminum and copper that cause coil corrosion in saline or corrosive environments.
- Enviro-shield™ coating for MCHE used in standard and mildly corrosive environments with superior durability confirmed through 5000 hours testing in constant neutral salt spray per ASTM B117 and superior heat transfer performances confirmed through 2000 hours testing per CM1 (Carrier proprietary testing).
- Super Enviro-shield™ coating for MCHE used in highly corrosive environments (industry or marine applications) with superior durability confirmed through 5000 hours testing in constant neutral salt spray per ASTM B117 and superior heat transfer performances confirmed through 2000 hours testing per CM1 (Carrier proprietary testing).

### ■ Evaporator:

- Carrier designed flooded evaporator with mechanically cleanable water tubes
- Electronic paddle-free flow switch to ensure prompt alarm in case of poor liquid flow rate
- Thermal insulation with aluminum sheet finish (option) improved resistance to mechanical and UV damage.

### ■ Refrigerant circuits:

- Two independent refrigerant circuits to secure partial cooling, if one of the two develops a fault.

### ■ Auto-adaptive control:

- Control algorithm prevents excessive compressor cycling (Carrier patent)
- Automatic compressor unloading in case of abnormally high condensing pressure. If condenser coil fouling or fan failure occurs, the Aquaforce continues to operate, but at reduced capacity.

### ■ Exceptional endurance tests:

- To design critical components and sub-assemblies to minimise the risk of failure on site, Carrier uses specialised laboratories and advanced dynamic simulation tools.
- To ensure that the units reach customer sites in the same condition as they are when tested in the factory, Carrier tests the machine behavior while being moved along a 250 km trial. The test-route is based on a military standard and is the equivalent to 5000km by truck in a normal road.
- To ensure coils corrosion resistance, salt mist corrosion resistance test are performed in Carrier's laboratory.

In addition, to maintain unit performance throughout its operating life, whilst minimising maintenance costs, end users can access the "Carrier Connect" remote monitoring service.

### Minimised operating sound levels

- The Greenspeed® Intelligence, featuring variable-speed screw compressors and condenser fans, minimises noise levels at part load operation.

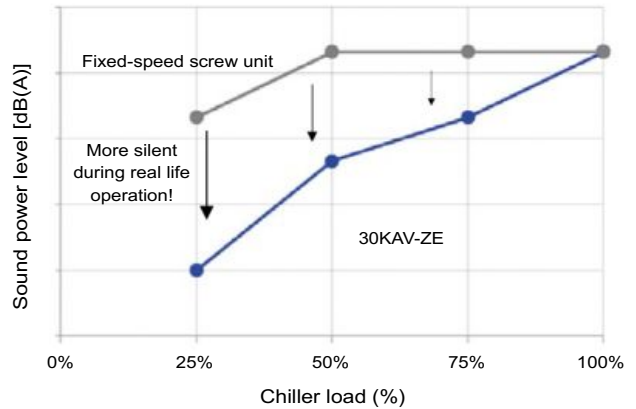

### ■ Standard unit features include:

- The new generation of Carrier 06Z variable-speed twin screw compressor with integrated resonator array to reduce the noise level by 6 dB(A) compared with 06T twin screw compressor previous generation.
- The 6<sup>th</sup> generation of silent Flying Bird™ fans with new fan blade design inspired by nature, help reduce airflow noise.

### ■ AquaForce® Vision is available with 3 sound levels to match the most sensitive environments:

- Standard: standard unit configuration with new generation of low sound screw compressor and fans
- Low noise option: addition of high-performance compressor sound enclosure
- Very low noise option: addition of high-performance compressor sound enclosure and fan operation at lower rotational speed.

### Easy and fast installation

- Built-in variable speed pumps up to 600kW
  - Full hydraulic module with dual pumps (low or high pressure as required) and optional expansion tank
  - Automatic nominal water flow adjustment through electronic control on the user display
- Compact units for easy transportation and installation.
  - Dimensions 25% smaller than the previous 30XAV generation
  - Similar dimensions as the old 30GX chillers for easy replacement of the installed base.
- Simplified electrical connections:
  - Main disconnect switch
  - Transformer supply to the integrated control circuit (400/24V)
  - Single electrical point of connection
- Simplified water connections:
  - Victaulic connections on the evaporator
  - Clearly identified entering and practical reference marks for entering and leaving water connections
  - Possibility to choose different evaporator configurations, 1 or 2 passes.
- Fast commissioning:
  - Systematic factory operating test before shipment
  - Functional test for main components, expansion devices, fans and compressors.

## AQUAFORCE® VISION CUSTOMER BENEFITS

### Environmental care

- The AquaForce® Vision with PUREtec™ refrigerant liquid chillers with Greenspeed® Intelligence is a boost for green cities and contributes to a sustainable future. Combining a reduced charge of R-1234ze refrigerant and exceptional energy efficiency it significantly lowers energy consumption while reducing carbon dioxide emissions by 25% throughout its life cycle (compared to previous fixed-speed screw liquid chiller generation).
- The AquaForce® Vision with PUREtec™ refrigerant liquid chiller is equipped with an automatic energy meter that provides estimated instantaneous and cumulative cooling energy output, instantaneous and cumulative electric energy consumption, instantaneous and average seasonal energy efficiency ratios (Accuracy: +/- 5% at nominal condition, +/-10% elsewhere) for unit performance monitoring and verification.
- R-1234ze: HFO refrigerant with zero ozone depletion potential
- 40% less refrigerant charge: The micro-channel technology used for condenser coils optimises heat transfer while minimising the refrigerant volume.
- Leak tight refrigerant circuits:
  - Reduction of leaks as no capillary tubes and flare connections are used
  - Verification of pressure transducers and temperature sensors without transferring refrigerant charge
  - Discharge line shut-off valve and liquid line service valve for simplified maintenance.
- Refrigerant leak alert: The AquaForce® Vision liquid chiller is equipped with an automatic refrigerant leak detection algorithm that can detect serious refrigerant loss at any point on the system (Sensitivity: 25% refrigerant charge loss per circuit, depending on the conditions). The automatic refrigerant leak detection system can help to achieve recognition within pollution prevention assessment programs, ideal for assisting in the design of sustainable buildings.
- Refrigerant leak detection: Available as an option, this additional dry-contact allows reporting of possible leaks. The leak detector (by others) should be mounted in the most likely leak location.



- R-1234ze long-term refrigerant solution
  - HFO refrigerant with nearly zero global warming potential (GWP<1 following AR5) and zero ozone depletion potential (ODP = 0).
  - Not impacted by the HFC phase-down plan in Europe (79% HFC reduction in EU member states at 2030 horizon)
  - Compliant with refrigerant regulation in Switzerland that bans the use of HFC refrigerant in large capacity airconditioning equipment.

- Leak-tight refrigerant circuit
  - Reduction of leaks as no capillary tubes and flare connections are used
  - Verification of pressure transducers and temperature sensors without transferring refrigerant charge
  - Discharge line shut-off valve and liquid line service valve for simplified maintenance.

### Designed to support Green Building Design

A green building is a building that is environmentally sustainable and has been designed, constructed and is operated to minimise the total impact on the environment.

The resulting building will be economical to operate, offer increased comfort and create a healthier environment for the people who live and work there, increasing productivity.

The air conditioning system can use between 30 and 40% of the annual building energy consumption. Selection of the right air conditioning system is one of the main aspects to consider when designing a green building. For buildings with a variable load throughout the year AquaForce® Vision offer a solution to this important challenge.

A number of green building certification programs exist in the market and offer third-party assessment of green building measures for a wide variety of building types.

The following example looks at how Carrier's new AquaForce® Vision range helps customers involved in LEED® building certification.

The other benefit of using the AQUAFORCE PUREtec™ products is the eligibility for BUILDING labeling programs like BREEAM, HQE in France or Green Building Council labelling, that are recognizing the use of sustainable heating and air-conditioning equipment.

Let's take the example of BREEAM assessment method for the sustainability of buildings.

Two credits can be awarded where the refrigerants used in air-conditioning systems have a Global Warming Potential below 10.

And one additional credit can be awarded where the systems have a low Total Equivalent Warming Impact.

AQUAFORCE PUREtec™ is not only a solution that is reducing the energy bill and the CO<sub>2</sub> footprint.

It also helps the green certification of your buildings!

### Energy saving certificate

AquaForce® Vision with with PUREtec™ refrigerant is eligible to Energy savings certificates in France (CEE) in comfort, industrial and agriculture applications:

- Floating High pressure control (by modulating the air flow through fan activation and its speed)
- Floating Low pressure control
- Variable speed on asynchronous compressor motor
- Variable speed on asynchronous fan motor
- Variable speed on asynchronous pump motor

30KAVPZE is equipped with variable speed synchronous compressor motor

For more details about financial incentives in France, please refer to "Fiche produit CEE"

## AQUAFORCE® VISION CUSTOMER BENEFITS

### 30KAV-ZE and LEED® certification

The LEED® (Leadership in Energy and Environmental Design) green building certification programme is a preeminent programme to rate the design, construction and operation of green buildings with points assigned in seven credit categories:

- Sustainable Sites (SS)
- Water Efficiency (WE)
- Energy & Atmosphere (EA)
- Materials & Resources (MR)
- Indoor Environmental Quality (IEQ)
- Innovation in Design (ID)
- Regional Priority (RP).

There are a number of different LEED® products.

While the strategies and categories assessed remain same, the point distribution varies to address different building types and application needs, for example according to New Construction, Schools, Core & Shell, Retail and Healthcare.

All programmes now use the same point scale:

#### 110 Possible LEED® points

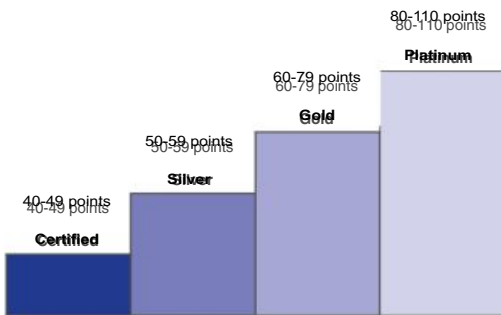

The majority of credits in LEED® rating systems are performance-based and achieving them is dependent on the impacts of each component or sub-system to the overall building.

While the LEED® green building certification programs do not certify products or services, the selection of the right products, systems or service programs is critical to obtain LEED® certification for a registered project, because the right products or service programmes can help meet the goals of green construction and ongoing operation and maintenance.

The choice of heating, ventilating and air conditioning (HVAC) products in particular can have a significant impact on LEED® certification, as the HVAC system directly impacts two categories that together influence 40% of the available points

#### Overview of LEED® for new construction and major renovations

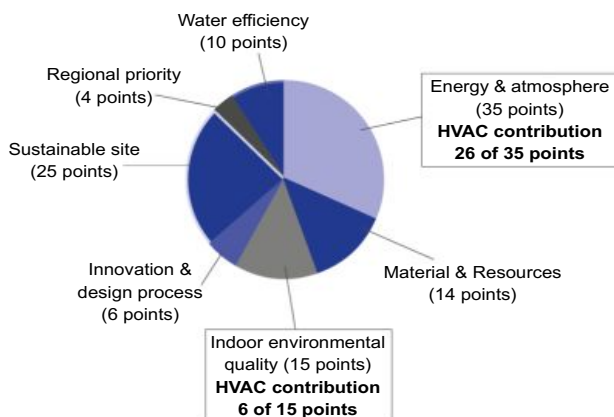

The new AquaForce® Vision with with PUREtec™ refrigerant units from Carrier can assist building owners to earn LEED® points in particular in the Energy & Atmosphere (EA) credit category and help address the following prerequisites and credit requirements:

- **EA prerequisite 2: Minimum energy Performance.**  
The AquaForce® Vision with with PUREtec™ refrigerant exceeds the energy efficiency requirements of ASHRAE 90,1-2007; therefore it complies with the prerequisite standard.
- **EA prerequisite 3: Fundamental Refrigerant Management**  
The AquaForce® Vision with with PUREtec™ refrigerant does not use chlorofluorocarbon (CFC) refrigerants thus satisfying the prerequisite statement.
- **EA credit 1: Optimise energy performance (1 to 19 points):**  
Points for this credit are assigned depending on the energy cost reduction virtually achievable by the new building, compared to ASHRAE 90,1-2007 reference. The AquaForce® Vision with with PUREtec™ refrigerant, which is designed for high performance especially during part load operation, contributes to reducing the energy consumption of the building and therefore helps in gaining points within this credit. In addition, the Carrier HAP (Hourly Analyses Program) can be used as an energy analyses program complying with the modeling requirements for this credit and produce reports that are easily transferable to LEED® templates.
- **EA credit 4: Enhanced refrigerant management (2 points):**  
With this credit, LEED® awards systems that minimise the Ozone Depletion Potential (ODP) and Global Warming Potential (GWP) of the system. The AquaForce® Vision with with PUREtec™ refrigerant uses a reduced R-1234ze charge and therefore contributes toward satisfying this credit under LEED®.

**NOTE: This section describes the prerequisites and credit requirements in LEED® for New Construction and is directly related to the AquaForce® Vision. Other prerequisites and credit requirements are not directly and purely related to the air-conditioning unit itself, but more to the control of the complete HVAC system.**

i-Vu®, Carrier's open control system, has features that can be valuable for:

- EA prerequisite 1: Fundamental commissioning of energy management system
- EA credit 3: Enhanced commissioning (2 points)
- EA credit 5: Measurements and verification (3 points).

**NOTE: Products are not reviewed or certified under LEED®, LEED® credit requirements cover the performance of materials in aggregate, not the performance of individual products or brands. For more information on LEED®, visit [www.usgbc.org](http://www.usgbc.org).**



## 30KAVIZE – TECHNICAL INSIGHTS

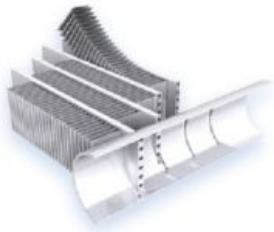

### 3<sup>RD</sup> GENERATION OF “W” SHAPE NOVATION® MICRO CHANNEL HEAT EXCHANGERS

- Exclusive Carrier design
- Increased reliability with new aluminum alloy
- Significantly reduces refrigerant charge (-40% vs cu/al coils)
- More compact units (-25% vs previous 30XAV generation)
- Enviro-shield™ coating for mildly corrosive environments
- Super Enviro-shield™ coating for highly corrosive environments (industry or marine applications)
- Easy cleaning with high pressure air or water washer

### ADVANCED SMARTVU™ WITH 7 INCH COLOR TOUCH SCREEN INTERFACE

- Exclusive Carrier design
- 10 languages available: DE, EN, ES, FR, IT, NL, PT, TR, TU + one additional customer choice
- Touch screen user interface
- BACnet, J-Bus or LON communication interfaces
- Optional wireless connectivity

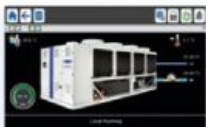

### POWERFUL SMART ENERGY MONITORING FUNCTION

- Provides smart data based on intelligent algorithms
- Real time energy consumption measurement (kWh)
- Cooling energy output measurement (kWh)
- Instantaneous and average Energy Efficiency Ratio under real operating conditions
- Remote monitoring with Carrier Connect

### FLOODED SHELL AND TUBE EVAPORATOR

- Exclusive Carrier design
- Flooded technology for high energy efficiency
- New generation of copper tubes with specific profile to reduce pressure drops when operating with glycol



### 6<sup>TH</sup> GENERATION OF VARIABLE-SPEED FLYING BIRD™ FANS WITH AC OR EC MOTOR

- Exclusive Carrier design
- Fan blade design inspired by nature
- AC motor technology
- High efficiency version with EC motor technology (option)



- HFO R-1234ze with Global Warming Potential (GWP) below 1.
- Long-term solution to meet the the F-Gas regulation.



### LATEST GENERATION CARRIER VARIABLE-SPEED 06Z TWIN SCREW COMPRESSOR WITH AC MOTOR

- Exclusive Carrier design
- Twin screw compressor designed for variable speed operation
- High efficiency AC motor
- Stepless variable-speed control (0%-100%)
- Integrated resonator array for compressor acoustic attenuation
- Integrated check valve for quiet shutdown
- Air-cooled inverter drive for increased reliability
- Bearing life exceeding 100.000 hours
- Twin screw compressor with permanent magnet motor as option



## 30KAV-ZE TECHNICAL INSIGHTS



### 3<sup>RD</sup> GENERATION OF “W” SHAPE NOVATION® MICRO CHANNEL HEAT EXCHANGERS

- Exclusive Carrier design
- Increased reliability with new aluminum alloy
- Significantly reduces refrigerant charge (-40% vs cu/al coils)
- More compact units (-25% vs previous 30XAV generation)
- Enviro-shield™ coating for mildly corrosive environments
- Super Enviro-shield™ coating for highly corrosive environments (industry or marine applications)
- Easy cleaning with high pressure air or water washer

### ADVANCED SMARTVU™ WITH 7 INCH COLOR TOUCH SCREEN INTERFACE

- Exclusive Carrier design
- 10 languages available: DE, EN, ES, FR, IT, NL, PT, TR, TU + one additional customer choice
- Touch screen user interface
- BACnet, J-Bus or LON communication interfaces
- Optional wireless connectivity

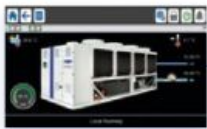

### POWERFUL SMART ENERGY MONITORING FUNCTION

- Provides smart data based on intelligent algorithms
- Real time energy consumption measurement (kWh)
- Cooling energy output measurement (kWh)
- Instantaneous and average Energy Efficiency Ratio under real operating conditions
- Remote monitoring with Carrier Connect

### FLOODED SHELL AND TUBE EVAPORATOR

- Exclusive Carrier design
- Flooded technology for high energy efficiency
- New generation of copper tubes with specific profile to reduce pressure drops when operating with glycol



### 6<sup>TH</sup> GENERATION OF VARIABLE-SPEED FLYING BIRD™ FANS WITH AC OR EC MOTOR

- Exclusive Carrier design
- Fan blade design inspired by nature
- AC motor technology
- High efficiency version with EC motor technology (option)



### VARIABLE-SPEED DUAL PUMPS WITH AC MOTOR

- Dual pumps designed for variable speed operation
- High efficiency AC motor
- Low static pressure (~100 kPa) or high static pressure (~180 Kpa) available
- 3 pump control modes available: constant water flow with 2 speeds, variable water flow based on constant delta T or constant delta P
- Compatibility of chillers for variable primary flow operation



### LATEST GENERATION CARRIER VARIABLE-SPEED 06Z TWIN SCREW COMPRESSOR WITH AC MOTOR

- Exclusive Carrier design
- Twin screw compressor designed for variable speed operation
- High efficiency AC motor
- Stepless variable-speed control (0%-100%)
- Integrated resonator array for compressor acoustic attenuation
- Integrated check valve for quiet shutdown
- Air-cooled inverter drive for increased reliability
- Bearing life exceeding 100.000 hours
- Twin screw compressor with permanent magnet motor as option



## 30KAVPZE TECHNICAL INSIGHTS



### 3<sup>RD</sup> GENERATION OF “W” SHAPE NOVATION® MICRO CHANNEL HEAT EXCHANGERS

- Extra W module to increase seasonal efficiency
- Extra W module to increase condensing surface and seasonal efficiency versus 30KAVZE
- Increased reliability with new aluminum alloy
- Significantly reduces refrigerant charge (-40% vs cu/al coils)
- Enviro-shield™ coating for mildly corrosive environments
- Super Enviro-shield™ coating for highly corrosive environments (industry or marine applications)
- Easy cleaning with high pressure air or water washer
- Extra W module to increase seasonal efficiency



### 6<sup>TH</sup> GENERATION OF VARIABLE-SPEED FLYING BIRD™ FANS WITH EC MOTOR

- Exclusive Carrier design
- Fan blade design inspired by nature
- High efficiency version with EC motor



### LATEST GENERATION CARRIER VARIABLE-SPEED 06Z TWIN SCREW COMPRESSOR WITH PERMANENT MAGNET MOTOR

- Exclusive Carrier design
- Twin screw compressor designed for variable speed operation
- High efficiency permanent magnet motor
- Stepless variable-speed control (0%-100%)
- Integrated resonator array for compressor acoustic attenuation
- Integrated check valve for quiet shutdown
- Air-cooled inverter drive for increased reliability
- Bearing life exceeding 100,000 hours

## TECHNICAL INSIGHTS

### SmartVu™ Control (standard)

#### SmartVu™



- New innovative smart control features:
  - An intuitive and user-friendly, coloured, 7" interface
  - 10 languages available on choice: DE, EN, ES, FR, IT, NL, PT, TR, TU + one additional customer choice
  - Screen-shots with concise and clear information in local languages
  - Complete menu, customised for different users (end user, service personnel and Carrier-factory technicians)
  - Setpoint offset based on the outside air temperature
  - Safe operation and unit setting: Password protection ensures that unauthorised people cannot modify any advanced parameters
  - Simple and "smart" intelligence uses data collection from the constant monitoring of all machine parameters to optimise unit operation
  - Night-mode: Cooling capacity management for reduced noise level.
  - With hydraulic module: Water pressure display and water flow rate calculation.
- Energy management:
  - Innovative smart energy monitoring, providing users with smart data such as real time electric energy consumption, cooling capacity, and instantaneous and average seasonal energy efficiency ratios.
  - Internal time schedule clock controls chiller on/off times and operation at a second set-point
  - The DCT (Data Collection Tool) records the alarms history to simplify and facilitate service operations.
- Maintenance functions
  - F-Gas regulation leak check reminder alert
  - Maintenance alert can be configured to days, months or hours of operation

- Advanced communication features
  - Easy and high-speed communication technology over Ethernet (IP) to a centralised building management system
  - Access to multiple unit parameters.

### Remote management (standard)

- Units with SmartVu™ control can be easily accessed from the internet, using a PC with an Ethernet connection. This makes remote control quick and easy and offers significant advantages for service operations.
- Aquaforce with Greenspeed® Intelligence is equipped with an RS485 serial port that offers multiple remote control, monitoring and diagnostic possibilities. When networked with other Carrier equipment through the CCN (Carrier Comfort Network - proprietary protocol), all components form a HVAC system fully-integrated and balanced through one of the Carrier's network system products, like the Chiller System Manager or the Plant System Manager (optional).
- Units also communicates with other building management systems via optional communication gateways (BACnet, LON or JBus).
- The following commands/visualisations are possible from remote connection:
  - Start/Stop of the machine
  - Dual set-point management: Through a dedicated contact is possible to activate a second set-point (example, unoccupied mode)
  - Demand limit setting: To limit the maximum chiller capacity to a predefined value
  - Water pump control: These outputs control the contactors of one/two evaporator water pumps.
  - Water pumps changeover (only with hydraulic module options): These contacts are used to detect a water pump operation fault and automatically change over to the other pump.
  - Operation visualisation: Indication if the unit is operating or if it is in stand-by (no cooling load)
  - Alarm visualisation.

### Remote management (EMM option)

- The Energy Management Module (EMM) offers extended remote control possibilities:
  - Room temperature: Permits set-point reset based on the building indoor air temperature (if Carrier thermostats are installed)
  - Set-point reset: Allows reset of the cooling set-point based on a 4-20 mA.
  - Demand limit 1 and 2: Closing of these contacts limits the maximum chiller capacity to two predefined values.
  - User safety: This contact can be used for any customer safety loop; opening the contact generates a specific alarm.
  - Ice storage end: When ice storage has finished, this input permits return to the second set-point (unoccupied mode).
  - Time schedule override: Closing of this contact cancels the programmed time schedule.
  - Out of service: This signal indicates that the chiller is completely out of service.
  - Chiller capacity: This analogue output (0-10 V) gives an immediate indication of the chiller capacity.
  - Alert indication: This volt-free contact indicates the necessity to carry out a maintenance operation or the presence of a minor fault.
  - Compressors running status: Set of outputs (as many as the compressors number) indicating which compressors are running.

## TECHNICAL INSIGHTS

### New generation of Carrier 06Z variable-speed twin screw compressor



The new generation of 06Z variable-speed twin screw compressors benefits from Carrier's long experience in the development of twin-rotor screw compressors. The 06Z compressor design is based on the successful 06T screw compressor, core of the well-known Aquaforce series with a number of modifications to reduce noise level and improve the energy efficiency especially during part load operation.

- New 06Z twin screw compressor optimized for variable speed operation: elimination of the slide valve, built-in volume index control (Vi) valve for both optimal full and part load performance, high efficiency AC motor with stepless inverter control from 20% to 100%.
- 30KAVPZE screw compressor is equipped with a Permanent Magnet (PM) Motor, which is a four pole motor compared to the two pole induction motor. By the way, the frequency setting doubles with PM motors, but the shaft speed remains the same. There is no slip or rotor losses. Thus, there is a benefit of +1% in full load efficiency and of +4% in part load efficiency.

Permanent Magnet Motor



- Separate air-cooled inverter drive for increased reliability
- New 06Z twin screw compressor design with Integrated Resonator Array (IRA) to reduce the sound level by up to 6 dB(A) when compared with previous 06T generation
- Integrated Check Valve for quiet shutdown
- Bearing life exceeding 100 000 hours.
- A dedicated oil separator is installed at the discharge of each compressor to ensure maximum oil return: Oil separates from refrigerant by gravity and returns to the low pressure side of the compressor without use of additional pumps.
- Volume index control (Vi) valve provides a reliable method of adjusting the compression ratio to better match system demand. It provides optimal performance regardless of operating condition
- Screw compressors work on the positive displacement principle to compress gas to a higher pressure. As a result, if there is an unusually high pressure in the condenser (due for example to coil fouling or operation in harsh climate) the compressor does not switch off, but continues operation at reduced capacity (unloaded mode).
- The silencer in the oil separator line (at the compressor outlet) considerably reduces discharge gas pulsations for much quieter operation.



## TECHNICAL INSIGHTS

### Novation® Heat Exchangers with Microchannel Coil Technology

Already utilised in the automobile and aeronautical industries for many years, the Novation™ Micro-Channel Heat Exchanger (MCHE) used in the Aquaforce is entirely made of aluminum. This one-piece concept significantly increases its corrosion resistance by eliminating the galvanic currents that are created when two different metals (copper and aluminum) come into contact in traditional heat exchangers.

- From the energy efficiency point-of-view the Novation® heat exchangers are approximately 10% more efficient than traditional coils and micro-channel coil technology allows a 40% reduction in the amount of refrigerant used in the chiller.
- The reduced depth of the Novation™ MCHE reduces air pressure losses by 50% and makes it much less susceptible to fouling (e.g. by sand). Cleaning of the Novation™ MCHE heat exchanger is very fast using a high pressure washer.
- To further enhance long-term performance, and protect coils from early deterioration, Carrier offers (as options) dedicated treatments for installations in corrosive environments.
  - The Novation™ MCHE with Enviro-Shield protection (option 262) is recommended for installations in moderately corrosive environments. The Enviro-Shield protection utilises corrosion inhibitors which actively arrest oxidation in case of mechanical damage.
  - The Novation™ MCHE with exclusive Super Enviro-Shield protection (option 263) is recommended for installations in corrosive environments. The Super Enviro-Shield protection consist of an extremely durable and flexible epoxy coating uniformly applied over all coil surfaces for complete isolation from the contaminated environment.
- After a total of more than 7,000 hours of testing following various test standards in Carrier laboratories, the Carrier Novation® MCHE with Super Enviro-shield® coating appears to be the best-suited customer choice to minimize the harmful effects of corrosive atmospheres and ensure long equipment life.
  - Best corrosion resistance per ASTM B117/D610 test
  - Best heat transfer performance per Carrier Marine 1 test
  - Proven reliability per ASTM B117 test

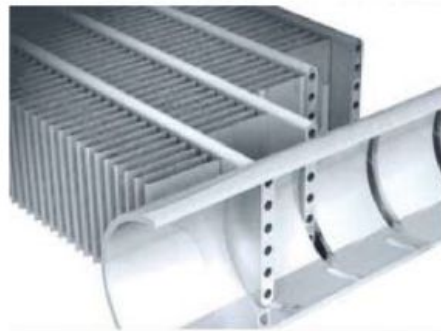

Coil Types (ranked by performance)	Visual Corrosion Evaluation	Heat Transfer Performance Degradation	Time to Failure	Test Campaign Conclusions
Super Enviro-shield® Novation™ MCHE	Very good	Very good	No coil leak	Best
Super Enviro-shield® Cu/Al coil	Very good	Very good	No coil leak	Very good
Enviro-shield® Novation™ MCHE	Very good	Good	No coil leak	Very good
Al/Al coil	Very good	Good	No coil leak	Very good
Novation™ MCHE	Good	Very good	No coil leak	Good
Cu/Cu coil	Good	Good	Leak before 5,000 h	Acceptable
Blygold® Cu/Al coil	Good	Good	No coil leak	Acceptable
Precoat Cu/Al coil	Bad	Bad	No coil leak	Bad
Cu/Al coil	Bad	Bad	No coil leak	Bad



## TECHNICAL INSIGHTS

### New generation of Flying Bird VI fans with EC motors



AquaForce® Vision utilizes Carrier's the 6th generation Flying Bird™ fan technology, engineered for maximum efficiency, super low noise, and wide operating range. The fan includes Carrier patented rotating shroud technology and back-swept blades with a unique wave-serration trailing edge inspired from nature.

It was designed and optimized for the AquaForce® Vision air management system configuration and heat exchanger technology. On 30KAVPZE, 30KAV-ZE and on 30KAVIZE with option 17 , fans are propelled by an EC motor, also known as brushless DC, with a unique electronics to manage commutation. This provides a great accuracy for fans that require higher efficiencies and variable speed. The fan meets the latest European eco-design requirements for fan efficiency. The fan uses Carrier's robust and proven injection molded composite-thermoplastic construction.

EC fan



## TECHNICAL INSIGHTS

### Variable Frequency Drives (VFD)

The compressors, AC fans and the pumps of AquaForce® Vision are controlled by VFDs.

- Electrical box is capable of operating up to 55°C (with option 16 "High Ambient").
- Unit regulation is designed to withstanding storage temperatures in the control compartment from -20°C to 68°C.
- All VFDs on the chiller (compressors, fans and pumps motors) are fully air cooled this differentiating from cooling systems on a glycol water loop and shall not require an additional glycol cooling system, thus avoiding the maintenance associated with such cooling systems.



Frequency converters fan drives + Pump drives + electronic boards



Frequency converters compressor drives + main power connection



## TECHNICAL INSIGHTS

### Actual Major product modification KAV(P)ZE : A

1	2	3	4	5	6	7	8	9	10	11	12	13	14	15	16	17	18
3	0	K	A	V	-	Z	E	0	8	0	0	A	-	-	-	-	-

#### Product codification

- Digit 5: Model series 30KAV
- Digits 6: Efficiency ('P' = Premium version)
- Digits 7 & 8: Unit using R1234ze refrigerant
- Digit 9 to 12: Number based on the cooling capacity in kW
- Digit 13: Major product modification
- Digit 14 to 17: Counter used to generate a one time product code
- Digit 18: '-' for single piece

### Actual Major product modification KAVIZE : -

1	2	3	4	5	6	7	8	9	10	11	12	13	14	15	16	17	18
3	0	K	A	V	I	Z	E	0	8	0	0	-	-	-	-	-	-

#### Product codification

- Digit 5: Model series 30KAV
- Digits 6: Efficiency ('P' = Premium version)
- Digits 7 & 8: Unit using R1234ze refrigerant
- Digit 9 to 12: Number based on the cooling capacity in kW
- Digit 13: Major product modification
- Digit 14 to 17: Counter used to generate a one time product code
- Digit 18: '-' for single piece



OPTIONS

Option	No.	Description	Advantage	Use 30KAV-ZE	Use 30KAVPZE	Use 30KAVIZE
Medium Brine down to -6°C	5	Redesigned evaporator to allow chilled brine solution production down to -6°C (including different number of tubes in the evaporator, extra insulation, specific sensors and algorithms).	Covers specific applications such as ice storage and industrial processes.	0350-1300	0350-0800	0500-1250
Low Brine with turbulators down to -12°C	6	Redesigned evaporator including turbulators to allow chilled brine solution production with low pressure drops on the entire negative application range, down to -12°C (including turbulators, extra insulation, specific sensors and algorithms).	Covers specific applications such as ice storage and industrial processes.	0350-1300	0350-0800	0500-1250
Low noise level	15	Aesthetic and sound absorbing compressor enclosure	Noise level reduction	0350-1300	0350-0800	0500-1250
Very low noise level	15LS	Sound absorbing & aesthetic compressor enclosure and oil separator, evaporator and suction line acoustic treatment, combined with low-speed fans	Noise level reduction for sensitive site	0350-1300	0350-0800	0500-1250
High ambient temperature	16	Electrical components sized for part load operation up to 55°C air ambient	Extended unit part-load operation up to 55°C ambient temperature	0350-1300	0350-0800	NO
EC fans	17	Unit equipped with EC fans	Enhances the unit energy efficiency	0350-1300	NO	0500-1250
IP54 control box	20A	Increased leak tightness of the unit	Protects the inside of the electrical box from dust, water and sand. In general this option is recommended for installations in polluted environments	0350-1300	0350-0800	0500-1250
Grilles and enclosure panels	23	Metal protection grilles and side enclosure panels	Improves aesthetics, protection against intrusion to the unit interior, coil and piping protection against impacts.	0350-1300	0350-0800	0500-1250
Enclosure panels	23A	Side enclosure panels	Improves aesthetics and piping protection against impacts.	0350-1300	0350-0800	0500-1250
Water exchanger frost protection	41A	Electric resistance heater on the water exchanger and discharge valve	Water exchanger frost protection down to -20°C outside temperature	0350-1300	0350-0800	0500-1250
Evaporator and hydraulic module frost protection	41B	Electric resistance heater on water exchanger, discharge valve and hydraulic module	Water exchanger and hydraulic module frost protection down to -20°C outside temperature	0350-0600	0350-0600	NO
Evaporator & recovery condenser frost protection	41C	Electric resistance heater on evaporator exchanger, discharge valve and add heaters and insulation on hydraulic connection (option 325)	Water exchanger module frost protection between 0°C and -20°C outside air temperature	0350-1300	0350-0800	0500-1250
Partial heat recovery	49	Unit equipped with one desuperheater on each refrigerant circuit	Production of free high-temperature hot-water simultaneously with chilled water production (or hot water for Heat pump)	0350-0800	0350-0800	NO
Total heat recovery	50	Unit equipped with an additional heat exchanger in series with the condenser coils (Each heat exchanger is equipped with electrical heaters and insulation)	Production of free hot-water with variable heat reclaim	0350-1300	0350-0800	0500-1250
Boosted Total Heat Recovery	50+	Unit equipped with additional heat exchanger in series with the condenser coils, and valves to isolate part of the coils.	Production of free hot-water simultaneously with chilled water production. Coils isolation reduce the condensing area leading to improve heat recovery efficiency.	0900-1300	NO	0500-1250
Master/slave operation	58	Unit equipped with supplementary leaving water temperature sensor kit (to be field installed) allowing master/slave operation of two units connected in parallel	Optimised operation of two units connected in parallel operation with operating time equalisation	0350-1300	0350-0800	0500-1250
Main disconnect switch with short-circuit protection	70D	Circuit breaker equipped with an external disconnect switch handle	Ensure protection of main disconnect switch and associated cables against short-circuits when building devices are not compliant	0350-1300	0350-0800	0500-1250
Evap. and pumps with aluminium jacket	88A	Evaporator and pumps covered with an aluminium sheet for thermal insulation protection	Improved resistance to aggressive climate conditions	0350-0600	0350-0600	NO
Service valve set	92	Liquid line valve (evaporator inlet) and compressor suction line valve	Allow isolation of various refrigerant circuit components for simplified service and maintenance	0350-1300	0350-0800	0500-1250
Compressor discharge valves	93A	Shut-off valve on the compressor discharge piping	Simplified maintenance	0350-1300	0350-0800	0500-1250
21 bar evaporator	104	Reinforced evaporator for extension of the maximum water-side service pressure to 21 bar (standard 10 bar)	Covers applications with a high water column on the condenser side (typically high buildings)	0350-1300	0350-0800	0500-1250



## OPTIONS

Option	No.	Description	Advantage	Use 30KAV-ZE	Use 30KAVPZE	Use 30KAVIZE
LP VSD dual-pump hydraulic mod.	116A	Dual low-pressure water pump with variable speed drive (VSD), pressure transducers. Multiple possibilities of water flow control. For more details, refer to the dedicated chapter.	Easy and fast installation (plug & play), significant pumping energy cost savings (more than two-thirds), tighter water flow control, improved system reliability	0350-0600	0350-0600	NO
HP VSD dual-pump hydraulic mod.	116W	Dual high-pressure water pump with variable speed drive (VSD), pressure transducers. Multiple possibilities of water flow control (expansion tank with built-in safety hydraulic components available in option)	Easy and fast installation (plug & play), significant pumping energy cost savings (up to two-thirds), tighter water flow control, improved system reliability	0350-0600	0350-0600	NO
High Energy Efficiency	119	Additional condenser coil to improve unit energy efficiency	Enhances the unit energy efficiency performance	0350-1100	NO	NO
High Energy Efficiency+	119+	Additional condenser coil plus EC fans to improve unit energy efficiency	Enhances the unit energy efficiency performance	0350-1100	NO	NO
Lon gateway	148D	Bi-directional communication board complying with Lon Talk protocol	Connects the unit by communication bus to a building management system	0350-1300	0350-0800	0500-1250
Bacnet over IP	149	Bi-directional high-speed communication using Bacnet protocol over Ethernet network (IP)	Easy and high-speed connection by ethernet line to a building management system. Allows access to multiple unit parameters	0350-1300	0350-0800	0500-1250
Modbus over IP and RS485	149B	Bi-directional high-speed communication using Modbus protocol over Ethernet network (IP)	Easy and high-speed connection by ethernet line to a building management system. Allows access to multiple unit parameters	0350-1300	0350-0800	0500-1250
Energy Management Module	156	EMM Control board with additional inputs/outputs. See Energy Management Module option chapter	Extended remote control capabilities (Set-point reset, ice storage end, demand limits, boiler on/off command...)	0350-1300	0350-0800	0500-1250
Input contact for Refrigerant leak detection	159	0-10 V signal to report any refrigerant leakage in the unit directly on the controller (the leak detector itself must be supplied by the customer)	Immediate customer notification of refrigerant losses to the atmosphere, allowing timely corrective actions	0350-1300	0350-0800	0500-1250
Dual relief valves on 3-way valve	194	Three-way valve upstream of dual relief valves on the shell and tubes evaporator	Valve replacement and inspection facilitated without refrigerant loss. Comforms to European standard EN378/BGVD4	0350-1300	0350-0800	0500-1250
Compliance with Swiss regulations	197	Additional tests on the water heat exchangers: supply (additional of PED documents) supplementary certificates and test certifications	Conformance with Swiss regulations	0350-1300	0350-0800	0500-1250
Compliance with Russian regulations	199	EAC certification	Conformance with Russian regulations	0350-1300	0350-0800	0500-1250
Compliance with Australian regulations	200	Unit approved to Australian code	Conformance with Australian regulations	0350-1300	0350-0800	0500-1250
Insulation of the evap. in/out ref. lines	256	Thermal insulation of the evaporator entering/leaving refrigerant lines with flexible, UV resistant insulation	Prevents condensation on the evaporator entering/leaving refrigerant lines	0350-1300	0350-0800	0500-1250
Enviro-Shield anti-corrosion protection	262	Coating by conversion process which modifies the surface of the aluminum producing a coating that is integral to the coil. Complete immersion in a bath to ensure 100% coverage. No heat transfer variation, tested 4000 hours salt spray per ASTM B117	Improved corrosion resistance, recommended for use in moderately corrosive environments	0350-1300	0350-0800	0500-1250
Super Enviro-Shield anti-corrosion protection	263	Extremely durable and flexible epoxy polymer coating applied on micro channel heat exchangers by electro coating process, final UV protective topcoat. Minimal heat transfer variation, tested 6000 hours constant neutral salt spray per ASTM B117, superior impact resistance per ASTM D2794	Improved corrosion resistance, recommended for use in extremely corrosive environments	0350-1300	0350-0800	0500-1250
Welded evaporator connection (kit)	266	Victaulic piping connections with welded joints	Easy installation	0350-1300	0350-0800	0500-1250
Welded heat recovery condenser connection (kit)	267	Victaulic piping connection with welded joints	Easy installation	0350-1300	0350-0800	0500-1250
Evaporator with aluminum jacket	281	Evaporator covered with an aluminum sheet for thermal insulation protection	Improved resistance to aggressive climate conditions	0350-1300	0350-0800	0500-1250
EMC class. C2, as per EN 61800-3	282	Additional RFI filters on the unit power line	Reduces electromagnetic interferences for compliance with emission level category C2 in order to allow the units to operate in the first environment (so called, residential environment)	0350-1300	0350-0800	0500-1250



OPTIONS

Option	No.	Description	Advantage	Use 30KAV-ZE	Use 30KAVPZE	Use 30KAVIZE
230V electrical plug	284	230V AC power supply source provided with plug socket and transformer (180 VA, 0,8 Amps)	Permits connection of a laptop or an electrical device during unit commissioning or servicing	0350-1300	0350-0800	0500-1250
Expansion tank	293	6 bar expansion tank integrated in the hydraulic module (requires hydraulic module option)	Easy and fast installation (plug & play), & Protection of closed water systems from excessive pressure	0350-0600	0350-0600	NO
Electric energy meter	294	Electricity meter . Display of energy consumption, instantaneous (U, V, I) and cumulated (kWh) on the unit user interface datas available on communication bus	Permits the acquisition, (remote) monitoring of energy used.	0350-1300	0350-0800	0500-1250
Fast Capacity Recovery	295	New software algorithms to allow quick restart and fast loading while preserving unit-reliability	Full capacity recovery in approximately 6 minutes after power failure. Matches requirements of typical critical missions applications	0350-1300	0350-0800	0500-1250
Ultra Fast Capacity Recovery	295+	Electrical capacity module to enable quick restart and fast loading preserving unit reliability	Ultra Fast full capacity recovery after power failure. Matches requirements of typical critical missions applications. (process, data centers)	0350-1300	0350-0800	0500-1250
Mexico screw compressor	297	Screw compressor made in Mexico	Mexico screw compressor	0350-1300	NO	0500-1250
Connected Services	298A	Transmit the machine's operating data in real time via a 4G LTEM network.	Monitor and control machine status remotely.	0350-1300	0350-0800	0500-1250
Variable Water Flow control	299	Hydraulic control function package that permits control of the water flow rate based on different possible logics (at customer choice): constant delta T, constant outlet pressure and "fixed-speed" control	When variable-speed pumps on the primary circuit, the VWF control modulates flow rate through the evaporator, minimising pump consumption while ensuring safe/optimised chiller operation	0350-1300	0350-0800	0500-1250
Free-cooling dry cooler control	313	Control & connections to a Free Cooling Dry cooler 09PE or 09VE fitted with option FC control box	Easy system management, Extended control capabilities to a dry cooler used in Free Cooling mode	0350-1300	0350-0800	0500-1250
Compliance with UAE regulation	318	Additional label on the unit with rated power input, rated current and EER following AHRI 550/590	Compliance with ESMA standard UAE.S 5010-5:2019.	0350-1300	0350-0800	0500-1250
Compliance with Qatar regulation	319	Specific nameplate on the unit with power supply 415 V+/-6%	Compliance with KAHRAMAA regulation in Qatar.	0350-1300	0350-0800	0500-1250
Hydraulic connection kit	325	Water piping on condenser and evaporator side	Easy installation	0350-1300	0350-0800	0800-1250
Compliance with Morocco regulation	327	Specifics documents according Morocco regulation	Conformance with Morocco regulations	0350-1300	0350-0800	0500-1250
Compressor with permanent magnet	329	Screw compressor equipped with permanent magnet motor	Permanent magnet motor improves significantly compressor efficiency	0350-0800	NO	0500-0800
Plastic Tarp	331	Plastic tarp covering units with strapping and campled on the wooden pallet	Allow unit to avoid dust and dirt from the outside environment during stocking and shipping	0350-1300	0350-0800	0500-1250

## PHYSICAL DATA

### Standard units - Units 350 - 800 kW

30KAV-ZE		350A	400A	450A	500A	550A	600A	650A	750A	800A			
<b>Cooling</b>													
<b>Standard unit</b> Full load performances*	CA1	Nominal capacity	kW		372	404	458	483	533	606	673	749	822
		EER	kW/kWh		3,10	3,02	3,13	3,09	3,15	3,15	3,18	3,17	3,20
<b>Standard unit</b> Seasonal energy efficiency **		<b>SEER</b> <sub>12/7°C</sub> <b>Comfort low temp.</b>	kWh/kWh		<b>4,97</b>	<b>4,94</b>	<b>5,16</b>	<b>5,14</b>	<b>5,29</b>	<b>5,19</b>	<b>5,18</b>	<b>5,15</b>	<b>5,29</b>
		$\eta_s$ cool <sub>12/7°C</sub>	%		196	195	203	203	209	205	204	203	209
		<b>SEPR</b> <sub>12/7°C</sub> <b>Process high temp.</b>	kWh/kWh		<b>6,50</b>	<b>6,37</b>	<b>6,56</b>	<b>6,53</b>	<b>6,71</b>	<b>6,53</b>	<b>6,64</b>	<b>6,51</b>	<b>6,60</b>
<b>Unit + option 17</b> Seasonal energy efficiency **		<b>SEER</b> <sub>12/7°C</sub> <b>Comfort low temp.</b>	kWh/kWh		<b>5,13</b>	<b>5,09</b>	<b>5,32</b>	<b>5,30</b>	<b>5,45</b>	<b>5,36</b>	<b>5,35</b>	<b>5,32</b>	<b>5,46</b>
		$\eta_s$ cool <sub>12/7°C</sub>	%		202	201	210	209	215	211	211	210	215
		<b>SEPR</b> <sub>12/7°C</sub> <b>Process high temp.</b>	kWh/kWh		<b>6,68</b>	<b>6,54</b>	<b>6,77</b>	<b>6,73</b>	<b>6,92</b>	<b>6,73</b>	<b>6,83</b>	<b>6,69</b>	<b>6,79</b>
<b>Unit + option 329</b> Seasonal energy efficiency **		<b>SEER</b> <sub>12/7°C</sub> <b>Comfort low temp.</b>	kWh/kWh		<b>5,23</b>	<b>5,19</b>	<b>5,38</b>	<b>5,35</b>	<b>5,49</b>	<b>5,43</b>	<b>5,40</b>	<b>5,38</b>	<b>5,51</b>
		$\eta_s$ cool <sub>12/7°C</sub>	%		206	204	212	211	217	214	213	212	217
		<b>SEPR</b> <sub>12/7°C</sub> <b>Process high temp.</b>	kWh/kWh		<b>6,71</b>	<b>6,55</b>	<b>6,72</b>	<b>6,67</b>	<b>6,84</b>	<b>6,70</b>	<b>6,78</b>	<b>6,68</b>	<b>6,76</b>
<b>Unit + option 17 + option 329</b> Seasonal energy efficiency **		<b>SEER</b> <sub>12/7°C</sub> <b>Comfort low temp.</b>	kWh/kWh		<b>5,40</b>	<b>5,35</b>	<b>5,56</b>	<b>5,53</b>	<b>5,66</b>	<b>5,62</b>	<b>5,58</b>	<b>5,57</b>	<b>5,70</b>
		$\eta_s$ cool <sub>12/7°C</sub>	%		213	211	219	218	223	222	220	220	225
		<b>SEPR</b> <sub>12/7°C</sub> <b>Process high temp.</b>	kWh/kWh		<b>6,91</b>	<b>6,74</b>	<b>6,93</b>	<b>6,88</b>	<b>7,06</b>	<b>6,90</b>	<b>6,99</b>	<b>6,87</b>	<b>6,95</b>
<b>Sound levels</b>													
<b>Standard unit</b>													
Sound power <sup>(1)</sup>		dB(A)		95	95	96	98	99	98	99	98	100	
Sound pressure at 10 m <sup>(2)</sup>		dB(A)		63	63	64	65	66	65	67	65	67	
Pression acoustique à 1 m		dB(A)		75	75	76	78	78	77	78	77	78	
<b>Dimensions</b>													
<b>Standard unit</b>													
Length		mm		4387	4387	5578	5578	6772	6772	7962	7962	9155	
Width		mm		2261	2261	2261	2261	2261	2261	2261	2261	2261	
Height		mm		2324	2324	2324	2324	2324	2324	2324	2324	2324	
<b>Operating weight<sup>(4)</sup></b>													
Standard unit		kg		4691	4700	5067	5077	5519	5951	6367	6813	7199	
<b>Compressors</b>													
<b>Standard unit</b>													
06Z twin screw variable speed with AC induction motor and variable frequency drive													
<b>Unit + option 329<sup>(3)(6)</sup></b>													
06Z twin screw variable speed with AC permanent magnet motor and variable frequency drive													
Circuit A	Quantity	1	1	1	1	1	1	1	1	1	1	1	
Circuit B	Quantity	1	1	1	1	1	1	1	1	1	1	1	
Unit minimum part load <sup>(5)</sup>	%	13	13	13	13	13	13	13	13	13	12	12	
<b>Refrigerant<sup>(4)</sup></b>													
R1234ze A2L (GWP=1 following AR5, ODP=0)													
Circuit A	kg	49	47	53	56	64	77	86	81	87			
	teqCO <sub>2</sub>	0,34	0,33	0,37	0,39	0,45	0,54	0,60	0,57	0,61			
Circuit B	kg	50	48	54	57	65	58	68	82	88			
	teqCO <sub>2</sub>	0,35	0,34	0,38	0,40	0,46	0,41	0,48	0,57	0,62			

\* In accordance with standard EN14511-3:2022.  
 \*\* In accordance with standard EN14825:2022, average climate  
 CA1 Cooling mode conditions: Evaporator water entering/leaving temperature 12°C/7°C, outside air temperature 35°C, evaporator fouling factor 0 m².K/W  
 **$\eta_s$  cool <sub>12/7°C</sub> & SEER <sub>12/7°C</sub> SEPR <sub>12/7°C</sub>** **Bold values compliant to Ecodesign regulation: (EU) No 2016/2281 for Comfort application**  
**Bold values compliant to Ecodesign regulation: (EU) No 2016/2281 for Process application High Temperature**  
 (1) In dB ref=10<sup>-12</sup> W, 'A' weighted. Declared dual-number noise emission values in accordance with ISO 4871 with an associated uncertainty of +/-3dB(A). Measured in accordance with ISO 9614-1 and certified by Eurovent.  
 (2) In dB ref 20µPa, 'A' weighted. Declared dual-number noise emission values in accordance with ISO 4871 with an associated uncertainty of +/-3dB(A). For information, calculated from the sound power Lw(A).  
 (3) Options: 15=Low noise level ; 15LS=Very low noise level ; 17=Fans motors EC type ; 329=Compressors motors PM type  
 (4) Values are guidelines only. Refer to the unit name plate.  
 (5) For standard conditions. Depending on operating conditions, unit might have a different minimum part load or cycle.  
 (6) Option 329 is not available on units 0900 to 1300.



Eurovent certified values

## PHYSICAL DATA

### Standard units - Units 350 - 800 kW

30KAV-ZE		350A	400A	450A	500A	550A	600A	650A	750A	800A
<b>Oil</b>		Oil for R1234ze. Contact Carrier ERCD for supplying.								
Circuit A	l	27	26	25	23	20	23	20	23	20
Circuit B	l	27	26	25	23	20	23	20	23	20
<b>Unit control</b>		SmartVu™ with 7 inch coloured touch screen interface								
Languages		10 languages (DE, EN, ES, FR, IT, NL, PT, TR, TU + one on customer choice)								
Smart energy metering		Standard feature								
Wireless connectivity		Option								
<b>Expansion valve</b>		Electronic expansion valve								
<b>Air heat exchanger</b>		Novation™ Micro Channel Heat Exchanger								
<b>Fans</b>										
<b>Standard unit</b>		Flying Bird™ VI impeller variable speed with AC motor and variable frequency drive								
<b>Unit + option 17<sup>(3)</sup></b>		Flying Bird™ VI impeller variable speed with EC motor								
Quantity		6	6	8	8	10	10	12	12	14
Maximum total air flow	l/s	35580	35580	47440	47440	59300	59300	71160	71160	83020
Maximum rotation speed	r/s	16,0	16,0	16,0	16,0	16,0	16,0	16,0	16,0	16,0
<b>Water heat exchanger</b>		Flooded shell and tube heat exchanger								
Water volume	l	83	88	96	100	115	126	144	165	183
Max. water-side operating pressure without hydraulic module	kPa	1000	1000	1000	1000	1000	1000	1000	1000	1000
<b>Water connections</b>		Victaulic® type								
<b>Standard unit</b>										
Connections	inch	5	5	6	6	6	6	8	8	8
Outside tube diameter	mm	141,3	141,3	168,3	168,3	168,3	168,3	219,1	219,1	219,1
<b>Casing paint</b>		Colour code RAL 7035								

(3) Options: 15=Low noise level ; 15LS=Very low noise level ; 17=Fans motors EC type ; 329=Compressors motors PM type

## PHYSICAL DATA

### Standard units - Units 900 - 1300 kW

30KAV-ZE		900A	1000A	1100A	1200A	1300A		
<b>Cooling</b>								
<b>Standard unit</b> Full load performances*	CA1	Nominal capacity	kW	935	1030	1140	1250	1344
		EER	kW/kW	3,07	3,14	3,24	3,20	2,93
<b>Standard unit</b> Seasonal energy efficiency **	SEER <sub>12/7°C</sub>	Comfort low temp.	kWh/kWh	<b>5,35</b>	<b>5,47</b>	<b>5,52</b>	<b>5,55</b>	<b>5,43</b>
		η <sub>s cool</sub> <sub>12/7°C</sub>	%	<b>211</b>	<b>216</b>	<b>218</b>	<b>219</b>	<b>214</b>
		SEPR <sub>12/7°C</sub>	Process high temp.	kWh/kWh	<b>6,20</b>	<b>6,27</b>	<b>6,37</b>	<b>6,26</b>
<b>Unit + option 17</b> Seasonal energy efficiency **	SEER <sub>12/7°C</sub>	Comfort low temp.	kWh/kWh	<b>5,49</b>	<b>5,62</b>	<b>5,67</b>	<b>5,70</b>	<b>5,57</b>
		η <sub>s cool</sub> <sub>12/7°C</sub>	%	<b>217</b>	<b>222</b>	<b>224</b>	<b>225</b>	<b>220</b>
		SEPR <sub>12/7°C</sub>	Process high temp.	kWh/kWh	<b>6,35</b>	<b>6,43</b>	<b>6,52</b>	<b>6,40</b>
<b>Unit + option 329</b> Seasonal energy efficiency **	SEER <sub>12/7°C</sub>	Comfort low temp.	kWh/kWh	<b>5,68</b>	<b>5,79</b>	<b>5,82</b>	<b>5,83</b>	<b>5,68</b>
		η <sub>s cool</sub> <sub>12/7°C</sub>	%	<b>224</b>	<b>229</b>	<b>230</b>	<b>230</b>	<b>224</b>
		SEPR <sub>12/7°C</sub>	Process high temp.	kWh/kWh	<b>6,45</b>	<b>6,51</b>	<b>6,58</b>	<b>6,44</b>
<b>Unit + option 17 + option 329</b> Seasonal energy efficiency **	SEER <sub>12/7°C</sub>	Comfort low temp.	kWh/kWh	<b>5,85</b>	<b>5,96</b>	<b>5,99</b>	<b>5,99</b>	<b>5,84</b>
		η <sub>s cool</sub> <sub>12/7°C</sub>	%	<b>231</b>	<b>235</b>	<b>236</b>	<b>237</b>	<b>231</b>
		SEPR <sub>12/7°C</sub>	Process high temp.	kWh/kWh	<b>6,62</b>	<b>6,67</b>	<b>6,74</b>	<b>6,59</b>
<b>Sound levels</b>								
<b>Standard unit</b>								
Sound power <sup>(1)</sup>		dB(A)	100	102	100	103	104	
Sound pressure at 10 m <sup>(2)</sup>		dB(A)	67	69	67	69	71	
Pression acoustique à 1 m		dB(A)	78	80	78	80	81	
<b>Dimensions</b>								
<b>Standard unit</b>								
Length		mm	9157	10347	11541	12731	12731	
Width		mm	2261	2261	2261	2261	2261	
Height		mm	2324	2324	2324	2324	2324	
<b>Operating weight<sup>(4)</sup></b>								
Standard unit		kg	8579	9002	9616	1690	9992	
<b>Compressors</b>								
<b>Standard unit</b>								
06Z twin screw variable speed with AC induction motor and variable frequency drive								
<b>Unit + option 329<sup>(3)(6)</sup></b>								
06Z twin screw variable speed with AC permanent magnet motor and variable frequency drive								
Circuit A	Quantity		1	1	1	1	1	
Circuit B	Quantity		1	1	1	1	1	
Unit minimum part load <sup>(5)</sup>	%		15	14	13	12	10	
<b>Refrigerant<sup>(4)</sup></b>								
R1234ze A2L (GWP=1 following AR5, ODP=0)								
Circuit A	kg		94	103	110	115	119	
	teqCO <sub>2</sub>		0,66	0,72	0,77	0,81	0,83	
Circuit B	kg		93	102	108	113	117	
	teqCO <sub>2</sub>		0,65	0,71	0,76	0,79	0,82	

\* In accordance with standard EN14511-3:2022.

\*\* In accordance with standard EN14825:2022, average climate

CA1 Cooling mode conditions: Evaporator water entering/leaving temperature 12°C/7°C, outside air temperature 35°C, evaporator fouling factor 0 m<sup>2</sup>.K/W

**η<sub>s cool</sub><sub>12/7°C</sub> & SEER<sub>12/7°C</sub>** **Bold values compliant to Ecodesign regulation: (EU) No 2016/2281 for Comfort application**

**SEPR<sub>12/7°C</sub>** **Bold values compliant to Ecodesign regulation: (EU) No 2016/2281 for Process application High Temperature**

(1) In dB ref=10<sup>-12</sup> W, 'A' weighted. Declared dual-number noise emission values in accordance with ISO 4871 with an associated uncertainty of +/-3dB(A). Measured in accordance with ISO 9614-1 and certified by Eurovent.

(2) In dB ref 20μPa, 'A' weighted. Declared dual-number noise emission values in accordance with ISO 4871 with an associated uncertainty of +/-3dB(A). For information, calculated from the sound power Lw(A).

(3) Options: 15=Low noise level ; 15LS=Very low noise level ; 17=Fans motors EC type ; 329=Compressors motors PM type

(4) Values are guidelines only. Refer to the unit name plate.

(5) For standard conditions. Depending on operating conditions, unit might have a different minimum part load or cycle.

(6) Option 329 is not available on units 0900 to 1300.



Eurovent certified values

## PHYSICAL DATA

### Standard units - Units 900 - 1300 kW

30KAV-ZE		900A	1000A	1100A	1200A	1300A
<b>Oil</b>		Oil for R1234ze. Contact Carrier ERCD for supplying.				
Circuit A	l	30	30	30	30	30
Circuit B	l	30	30	30	30	30
<b>Unit control</b>		SmartVu™ with 7 inch coloured touch screen interface				
Languages		10 languages (DE, EN, ES, FR, IT, NL, PT, TR, TU + one on customer choice)				
Smart energy metering		Standard feature				
Wireless connectivity		Option				
<b>Expansion valve</b>		Electronic expansion valve				
<b>Air heat exchanger</b>		Novation™ Micro Channel Heat Exchanger				
<b>Fans</b>						
<b>Standard unit</b>		Flying Bird™ VI impeller variable speed with AC motor and variable frequency drive				
<b>Unit + option 17<sup>(3)</sup></b>		Flying Bird™ VI impeller variable speed with EC motor				
Quantity		14	16	18	20	20
Maximum total air flow	l/s	83020	94880	106740	118600	118600
Maximum rotation speed	r/s	16,0	16,0	16,0	16,0	16,0
<b>Water heat exchanger</b>		Flooded shell and tube heat exchanger				
Water volume	l	178	224	243	261	270
Max. water-side operating pressure without hydraulic module	kPa	1000	1000	1000	1000	1000
<b>Water connections</b>		Victaulic® type				
<b>Standard unit</b>						
Connections	inch	8	8	8	8	8
Outside tube diameter	mm	219,1	219,1	219,1	219,1	219,1
<b>Casing paint</b>		Colour code RAL 7035				

(3) Options: 15=Low noise level ; 15LS=Very low noise level ; 17=Fans motors EC type ; 329=Compressors motors PM type



## PHYSICAL DATA

### Standard units - option 15&15LS

#### Units 350 - 1300 kW

30KAV-ZE		0350A	0400A	0450A	0500A	0550A	0600A	0650A	0750A
<b>Sound levels</b>									
<b>Unit + option 15</b>									
Sound power <sup>(1)</sup>	dB(A)	94	94	94	96	97	96	97	97
Sound pressure at 10 m <sup>(2)</sup>	dB(A)	62	62	61	64	64	63	65	64
Sound pressure at 1m	dB(A)	74	74	74	76	76	75	76	76
<b>Unit + option 15LS</b>									
Sound power <sup>(1)</sup>	dB(A)	90	90	90	92	94	92	94	93
Sound pressure at 10 m <sup>(2)</sup>	dB(A)	57	58	58	59	61	60	62	60
Sound pressure at 1m	dB(A)	70	70	70	72	73	71	73	72
<b>Fans</b>									
Quantity		6	6	8	8	10	10	12	12
Maximum total air flow + option 15LS	l/s	28920	26100	41600	43200	56000	50000	67200	57840
Maximum rotation speed + option 15LS	r/s	13,2	12,0	14,2	14,7	15,2	13,7	15,2	13,2

30KAV-ZE		0800A	0900A	1000A	1100A	1200A	1300A
<b>Sound levels</b>							
<b>Unit + option 15</b>							
Sound power <sup>(1)</sup>	dB(A)	98	98	100	98	100	99
Sound pressure at 10 m <sup>(2)</sup>	dB(A)	65	65	67	65	67	66
Sound pressure at 1m	dB(A)	76	76	78	75	77	76
<b>Unit + option 15LS</b>							
Sound power <sup>(1)</sup>	dB(A)	94	96	96	97	98	98
Sound pressure at 10 m <sup>(2)</sup>	dB(A)	61	63	74	64	65	65
Sound pressure at 1m	dB(A)	72	74	74	75	75	75
<b>Fans</b>							
Quantity		14	14	16	18	20	20
Maximum total air flow + option 15LS	l/s	72800	74200	84800	95400	106000	106000
Maximum rotation speed + option 15LS	r/s	14,2	14,4	14,4	14,4	14,4	14,4

(1) In dB ref=10<sup>-12</sup> W, 'A' weighted. Declared dual-number noise emission values in accordance with ISO 4871 with an associated uncertainty of +/-3dB(A). Measured in accordance with ISO 9614-1 and certified by Eurovent.

(2) In dB ref 20µPa, 'A' weighted. Declared dual-number noise emission values in accordance with ISO 4871 with an associated uncertainty of +/-3dB(A). For information, calculated from the sound power Lw(A).



Eurovent certified values

PHYSICAL DATA

30KAV-ZE option 119 and 30KAVPZE

30KAV-ZE option 119			350A	400A	450A	500A	550A	600A	650A	750A	800A	900A	1000A	1100A	
<b>Cooling</b>															
Unit + option 119 + 17 Full load performances*	CA1	Nominal capacity	kW	380	421	464	491	541	625	683	767	836	952	1046	1149
		EER	kW/kW	3,41	3,38	3,31	3,23	3,22	3,34	3,26	3,33	3,29	3,29	3,33	3,33
Unit + option 119 Seasonal energy efficiency **	CA1	SEER <sub>12/7°C</sub> Comfort	kWh/kWh	5,13	5,16	5,27	5,28	5,34	5,24	5,19	5,17	5,30	5,60	5,70	5,64
		η <sub>s cool</sub> 12/7°C	%	202	203	208	208	210	206	205	204	209	221	225	222
		SEPR <sub>12/7°C</sub> Process	kWh/kWh	7,26	7,09	6,96	6,88	6,97	6,94	6,84	6,88	6,76	6,54	6,58	6,47
Unit + option 119 + 17 Seasonal energy efficiency **	CA1	SEER <sub>12/7°C</sub> Comfort	kWh/kWh	5,30	5,33	5,44	5,45	5,50	5,41	5,36	5,34	5,47	5,76	5,87	5,79
		η <sub>s cool</sub> 12/7°C	%	209	210	215	215	217	213	211	211	216	228	232	229
		SEPR <sub>12/7°C</sub> Process	kWh/kWh	7,45	7,28	7,16	7,09	7,17	7,13	7,04	7,07	6,95	6,70	6,74	6,62
30KAVPZE			350A	400A	450A	500A	550A	600A	650A	750A	800A				
Standard unit Full load performances*	CA1	Nominal capacity	kW	380	421	464	491	541	625	683	767	836			
		EER	kW/kW	3,57	3,53	3,45	3,36	3,36	3,48	3,40	3,47	3,42			
Standard unit Seasonal energy efficiency **	CA1	SEER <sub>12/7°C</sub> Comfort	kWh/kWh	5,60	5,60	5,69	5,69	5,71	5,67	5,59	5,59	5,61			
		η <sub>s cool</sub> 12/7°C	%	221	221	225	224	225	224	221	221	222			
		SEPR <sub>12/7°C</sub> Process	kWh/kWh	7,71	7,49	7,33	7,24	7,31	7,31	7,19	7,26	7,11			
30KAV-ZE option 119 & 30KAVPZE (7) (8)			350A	S400A	450A	500A	550A	600A	650A	750A	800A	900A	1000A	1100A	
<b>Sound levels</b>															
<b>Unit</b>															
Sound power <sup>(1)</sup>		dB(A)	96	96	97	98	99	98	100	98	100	100	102	100	
Sound pressure at 10 m <sup>(2)</sup>		dB(A)	63	63	64	66	66	65	67	65	67	67	69	67	
Pression acoustique à 1 m		dB(A)	76	76	76	78	78	77	78	77	78	78	79	77	
<b>Dimensions</b>															
<b>Unit</b>															
Length		mm	6772	6772	6772	6772	7962	9155	9120	10346	10346	11541	12731	12731	
Width		mm	2261	2261	2261	2261	2261	2261	2261	2261	2261	2261	2261	2261	
Height		mm	2324	2324	2324	2324	2324	2324	2324	2324	2324	2324	2324	2324	
<b>Operating weight<sup>(4)</sup></b>															
Unit		kg	5395	5402	5415	5418	5822	6615	6724	7479	7508	9274	9690	9992	
<b>Compressors</b>															
30KAV-ZE option 119 (7)			06Z twin screw variable speed with AC induction motor and variable frequency drive												
30KAV-ZE option 119 (7) + option 329 (6) & 30KAVPZE (8) (3)			06Z twin screw variable speed with AC permanent magnet motor and variable frequency drive												
Circuit A	Quantity		1	1	1	1	1	1	1	1	1	1	1	1	
Circuit B	Quantity		1	1	1	1	1	1	1	1	1	1	1	1	
Unit minimum part load (5)	%		13	13	13	13	13	13	13	13	12	12	15	14	13

\* In accordance with standard EN14511-3:2022.  
 \*\* In accordance with standard EN14825:2022, average climate  
 \*\*\* With EG 30%  
 CA1 Cooling mode conditions: Evaporator water entering/leaving temperature 12°C/7°C, outside air temperature 35°C, evaporator frosting factor 0 m<sup>2</sup>.K/W  
 η<sub>s cool</sub> 12/7°C & SEER 12/7°C **Bold values compliant to Ecodesign regulation: (EU) No 2016/2281 for Comfort application**  
 SEPR 12/7°C **Bold values compliant to Ecodesign regulation: (EU) No 2016/2281 for Process application High Temperature**  
 (1) In dB ref=10<sup>-12</sup> W, 'A' weighted. Declared dual-number noise emission values in accordance with ISO 4871 with an associated uncertainty of +/-3dB(A). Measured in accordance with ISO 9614-1 and certified by Eurovent.  
 (2) In dB ref 20μPa, 'A' weighted. Declared dual-number noise emission values in accordance with ISO 4871 with an associated uncertainty of +/-3dB(A). For information, calculated from the sound power Lw(A).  
 (3) Options: 15=Low noise level ; 15LS=Very low noise level ; 17=Fans motors EC type ; 329=Compressors motors PM type  
 (6) Option 329 is not available on units 0900 to 1300.  
 (7) Option 119 is not available with units 1200 to 1300.  
 (8) 30KAVPZE premium version is not available with units 0900 to 1300.



Eurovent certified values

## PHYSICAL DATA

### 30KAV-ZE option 119 and 30KAVPZE

30KAV-ZE option 119 & 30KAVPZE <sup>(7)</sup> <sup>(8)</sup>		350A	S400A	450A	500A	550A	600A	650A	750A	800A	900A	1000A	1100A
<b>Refrigerant<sup>(4)</sup></b>		R1234ze A2L (GWP=1 following AR5, ODP=0)											
Circuit A	kg	65	62	63	61	68	88	92	92	93	114	124	125
	teqCO <sub>2</sub>	0,46	0,43	0,44	0,43	0,48	0,62	0,64	0,64	0,65	0,80	0,87	0,88
Circuit B	kg	66	63	63	62	69	69	74	93	94	113	123	123
	teqCO <sub>2</sub>	0,46	0,44	0,44	0,43	0,48	0,48	0,52	0,65	0,66	0,79	0,86	0,86
<b>Oil</b>		Oil for R1234ze. Contact Carrier ERCD for supplying.											
Circuit A	l	27	26	25	23	20	23	20	23	20	30	30	30
Circuit B	l	27	26	25	23	20	23	20	23	20	30	30	30
<b>Unit control</b>		SmartVu™ with 7 inch colored touch screen interface											
Languages		10 languages (DE, EN, ES, FR, IT, NL, PT, TR, TU + one on customer choice)											
Smart energy metering		Standard feature											
Wireless connectivity		Option											
<b>Expansion valve</b>		Electronic expansion valve											
<b>Air heat exchanger</b>		Novation™ Micro Channel Heat Exchanger											
<b>Fans</b>													
<b>30KAV-ZE option 119 <sup>(7)</sup></b>		Flying Bird™ VI impeller variable speed with AC motor and variable frequency drive											
<b>30KAV-ZE option 119<sup>(7)</sup> + option 17 &amp; 30KAVPZE<sup>(8)</sup> <sup>(3)</sup></b>		Flying Bird™ VI impeller variable speed with EC motor											
Quantity		10	10	10	10	12	14	14	16	16	18	20	20
Maximum total air flow	l/s	59300	59300	59300	59300	71160	83020	83020	94880	94880	106740	118600	118600
Maximum rotation speed	r/s	16,0	16,0	16,0	16,0	16,0	16,0	16,0	16,0	16,0	16	16	16
<b>Water heat exchanger</b>		Flooded shell and tube heat exchanger											
Water volume	l	83	88	96	100	115	126	144	165	183	178	224	243
Max. water-side operating pressure without hydraulic module	kPa	1000	1000	1000	1000	1000	1000	1000	1000	1000	1000	1000	1000
<b>Water connections</b>		Victaulic® type											
<b>Standard unit</b>													
Connections	inch	5	5	6	6	6	6	8	8	8	8	8	8
Outside tube diameter	mm	141,3	141,3	168,3	168,3	168,3	168,3	219,1	219,1	219,1	219,1	219,1	219,1
<b>Casing paint</b>		Colour code RAL 7035											

(3) Options: 15=Low noise level ; 15LS=Very low noise level ; 17=Fans motors EC type ; 329=Compressors motors PM type

(4) Values are guidelines only. Refer to the unit name plate.

(7) Option 119 is not available with units 1200 to 1300.

(8) 30KAVPZE premium version is not available with units 0900 to 1300.

## PHYSICAL DATA

### 30KAV-ZE option 119 and 30KAVPZE - option 15&15LS

30KAV-ZE option 119 & 30KAVPZE (7) (8)		0350A	0400A	0450A	0500A	0550A	0600A	0650A
<b>Sound levels</b>								
<b>Unit + option 15</b>								
Sound power <sup>(1)</sup>	dB(A)	95	95	94	96	97	96	98
Sound pressure at 10 m <sup>(2)</sup>	dB(A)	62	62	62	64	64	64	65
Sound pressure at 1m	dB(A)	74	74	74	76	76	76	76
<b>Unit + option 15LS</b>								
Sound power <sup>(1)</sup>	dB(A)	90	91	91	92	94	92	94
Sound pressure at 10 m <sup>(2)</sup>	dB(A)	57	58	58	59	61	60	61
Sound pressure at 1m	dB(A)	69	70	70	72	73	71	72
<b>Fans</b>								
Quantity		10	10	10	10	12	14	14
Maximum total air flow + option 15LS	l/s	44700	43500	52000	52000	64800	67480	75600
Maximum rotation speed + option 15LS	r/s	12,3	12,0	14,2	14,2	14,7	13,2	14,7

30KAV-ZE option 119 & 30KAVPZE (7) (8)		0750A	0800A	0900A	1000A	1100A
<b>Sound levels</b>						
<b>Unit + option 15</b>						
Sound power <sup>(1)</sup>	dB(A)	98	98	98	100	98
Sound pressure at 10 m <sup>(2)</sup>	dB(A)	65	65	65	67	65
Sound pressure at 1m	dB(A)	76	76	76	77	75
<b>Unit + option 15LS</b>						
Sound power <sup>(1)</sup>	dB(A)	93	94	96	97	97
Sound pressure at 10 m <sup>(2)</sup>	dB(A)	60	61	63	63	64
Sound pressure at 1m	dB(A)	71	72	74	74	74
<b>Fans</b>						
Quantity		16	16	18	20	20
Maximum total air flow + option 15LS	l/s	74080	83200	95220	105800	105800
Maximum rotation speed + option 15LS	r/s	12,7	14,2	14,4	14,4	14,4

- (1) In dB ref=10<sup>-12</sup> W, 'A' weighted. Declared dual-number noise emission values in accordance with ISO 4871 with an associated uncertainty of +/-3dB(A). Measured in accordance with ISO 9614-1 and certified by Eurovent.
- (2) In dB ref 20µPa, 'A' weighted. Declared dual-number noise emission values in accordance with ISO 4871 with an associated uncertainty of +/-3dB(A). For information, calculated from the sound power Lw(A).
- (7) Option 119 is not available with units 1200 to 1300.
- (8) 30KAVPZE premium version is not available with units 0900 to 1300.



Eurovent certified values

## PHYSICAL DATA

### 30KAVIZE

30KAVIZE			500	800	1100	1250	
<b>Cooling</b>							
<b>Standard unit Full load performances*</b>	CA1	Nominal capacity	kW	532	781	1120	1307
		EER	kW/kW	2,79	2,85	3,02	2,59
	***	Nominal capacity	kW	283	454	682	804
		EER	kW/kW	1,83	1,82	2,05	1,90
<b>Standard unit Seasonal energy efficiency**</b>		<b>SEER</b> <sub>12/7°C</sub> <b>Comfort low temp.</b>	<b>kWh/kWh</b>	<b>4,73</b>	<b>5,00</b>	<b>5,22</b>	<b>5,02</b>
		<b>ηs cool</b> <sub>12/7°C</sub>	<b>%</b>	<b>186</b>	<b>197</b>	<b>206</b>	<b>198</b>
		<b>SEPR</b> <sub>12/7°C</sub> <b>Process high temp.</b>	<b>kWh/kWh</b>	<b>5,62</b>	<b>6,03</b>	<b>5,95</b>	<b>5,55</b>
		<b>SEPR</b> <sub>-2/-8°C</sub> <b>Process medium temp.</b>	<b>kWh/kWh</b>	<b>3,55</b>	<b>3,61</b>	<b>3,74</b>	<b>3,57</b>
<b>Unit + option 17 Seasonal energy efficiency**</b>		<b>SEER</b> <sub>12/7°C</sub> <b>Comfort low temp.</b>	<b>kWh/kWh</b>	<b>4,84</b>	<b>5,14</b>	<b>5,35</b>	<b>5,13</b>
		<b>ηs cool</b> <sub>12/7°C</sub>	<b>%</b>	<b>191</b>	<b>202</b>	<b>211</b>	<b>202</b>
		<b>SEPR</b> <sub>12/7°C</sub> <b>Process high temp.</b>	<b>kWh/kWh</b>	<b>5,75</b>	<b>6,20</b>	<b>6,08</b>	<b>5,66</b>
		<b>SEPR</b> <sub>-2/-8°C</sub> <b>Process medium temp.</b>	<b>kWh/kWh</b>	<b>3,61</b>	<b>3,68</b>	<b>3,82</b>	<b>3,64</b>
<b>Unit + option 329 Seasonal energy efficiency**</b>		<b>SEER</b> <sub>12/7°C</sub> <b>Comfort low temp.</b>	<b>kWh/kWh</b>	<b>4,90</b>	<b>5,22</b>	-	-
		<b>ηs cool</b> <sub>12/7°C</sub>	<b>%</b>	<b>193</b>	<b>206</b>	-	-
		<b>SEPR</b> <sub>12/7°C</sub> <b>Process high temp.</b>	<b>kWh/kWh</b>	<b>5,73</b>	<b>6,18</b>	-	-
		<b>SEPR</b> <sub>-2/-8°C</sub> <b>Process medium temp.</b>	<b>kWh/kWh</b>	<b>3,62</b>	<b>3,69</b>	-	-
<b>Unit + option 17 + option 329 Seasonal energy efficiency**</b>		<b>SEER</b> <sub>12/7°C</sub> <b>Comfort low temp.</b>	<b>kWh/kWh</b>	<b>5,02</b>	<b>5,36</b>	-	-
		<b>ηs cool</b> <sub>12/7°C</sub>	<b>%</b>	<b>198</b>	<b>211</b>	-	-
		<b>SEPR</b> <sub>12/7°C</sub> <b>Process high temp.</b>	<b>kWh/kWh</b>	<b>5,87</b>	<b>6,35</b>	-	-
		<b>SEPR</b> <sub>-2/-8°C</sub> <b>Process medium temp.</b>	<b>kWh/kWh</b>	<b>3,69</b>	<b>3,77</b>	-	-
<b>Sound levels</b>							
<b>Standard unit</b>							
Sound power <sup>(1)</sup>		dB(A)	102	103	101	105	
Sound pressure at 10 m <sup>(2)</sup>		dB(A)	70	70	68	72	
Pression acoustique à 1 m		dB(A)	82	82	79	83	
<b>Dimensions</b>							
<b>Standard unit</b>							
Length		mm	4350	6735	9157	9157	
Width		mm	2261	2261	2261	2261	
Height		mm	2324	2324	2324	2324	
<b>Operating weight<sup>(4)</sup></b>							
Standard unit		kg	4877	6679	9143	9266	

\* In accordance with standard EN14511-3:2022.

\*\* In accordance with standard EN14825:2022, average climate

\*\*\* Cooling mode conditions: Evaporator with turbulators (option Brine 6), MEG 30%, entering/leaving temperature -4°C/8°C, outside air temperature 35°C, evaporator fooling factor 0 m<sup>2</sup>.K/W

CA1 Cooling mode conditions: Evaporator water entering/leaving temperature 12°C/7°C, outside air temperature 35°C, evaporator fooling factor 0 m<sup>2</sup>.K/W

**ηs cool** <sub>12/7°C</sub> & **SEER** <sub>12/7°C</sub> **Bold values compliant to Ecodesign regulation: (EU) No 2016/2281 for Comfort application**

**SEPR** <sub>12/7°C</sub> **Bold values compliant to Ecodesign regulation: (EU) No 2016/2281 for Process application High Temperature**

**SEPR** <sub>-2/-8°C</sub> **Bold values compliant to Ecodesign regulation: (EU) No 2015/1095 for Process application Medium Temperature**

(1) In dB ref=10<sup>-12</sup> W, 'A' weighted. Declared dual-number noise emission values in accordance with ISO 4871 with an associated uncertainty of +/-3dB(A). Measured in accordance with ISO 9614-1 and certified by Eurovent.

(2) In dB ref 20μPa, 'A' weighted. Declared dual-number noise emission values in accordance with ISO 4871 with an associated uncertainty of +/-3dB(A). For information, calculated from the sound power Lw(A).

(4) Values are guidelines only. Refer to the unit name plate



Eurovent certified values



## PHYSICAL DATA

30KAVIZE		500	800	1100	1250	
<b>Compressors</b>						
<b>Standard unit</b>		06Z twin screw variable speed with AC induction motor and variable frequency drive				
<b>Unit + option 329</b> <sup>(3) (6)</sup>		06Z twin screw variable speed with AC permanent magnet motor and variable frequency drive				
Circuit A	Quantity	1	1	1	1	
Circuit B	Quantity	1	1	1	1	
Unit minimum part load <sup>(5)</sup>		%	13	12	13	10
<b>Refrigerant</b> <sup>(4)</sup>		R1234ze A2L (GWP=1 following AR5, ODP=0)				
Circuit A	kg	54	80	114	118	
	teqCO <sub>2</sub>	0,38	0,56	0,80	0,83	
Circuit B	kg	55	81	112	116	
	teqCO <sub>2</sub>	0,39	0,57	0,78	0,81	
<b>Oil</b>		Oil for R1234ze. Contact Carrier ERCD for supplying.				
Circuit A	l	20	20	30	30	
Circuit B	l	20	20	30	30	
<b>Unit control</b>		SmartVu™ with 7 inch coloured touch screen interface				
Languages		10 languages (DE, EN, ES, FR, IT, NL, PT, TR, TU + one on customer choice)				
Smart energy metering		Standard feature				
Wireless connectivity		Option				
<b>Expansion valve</b>		Electronic expansion valve				
<b>Air heat exchanger</b>		Novation™ Micro Channel Heat Exchanger				
<b>Fans</b>						
<b>Standard unit</b>		Flying Bird™ VI impeller variable speed with AC motor and variable frequency drive				
<b>Unit + option 17</b> <sup>(3)</sup>		Flying Bird™ VI impeller variable speed with EC motor				
Quantity		6	10	14	14	
Maximum total air flow		l/s	35580	59300	83020	83020
Maximum rotation speed		r/s	16,0	16,0	16,0	16,0
<b>Water heat exchanger</b>		Flooded shell and tube heat exchanger				
Water volume		l	115	183	243	270
Max. water-side operating pressure without hydraulic module		kPa	1000	1000	1000	1000
<b>Water connections</b>		Victaulic® type				
<b>Standard unit</b>						
Connections		inch	6	8	8	8
Outside tube diameter		mm	168,3	219,1	219,1	219,1
<b>Casing paint</b>		Colour code RAL 7035				

(3) Options: 15=Low noise level ; 15LS=Very low noise level ; 17=Fans motors EC type ; 329=Compressors motors PM type

(4) Values are guidelines only. Refer to the unit name plate.

(5) For standard conditions. Depending on operating conditions, unit might have a different minimum part load or cycle

(6) Option 329 is not available on units 0900 to 1300.

## PHYSICAL DATA

### 30KAVIZE - option 15&15LS

30KAVIZE		500	800	1100	1250
<b>Sound levels</b>					
<b>Unit + option 15</b>					
Sound power <sup>(1)</sup>	dB(A)	98	100	98	101
Sound pressure at 10 m <sup>(2)</sup>	dB(A)	66	67	65	68
Sound pressure at 1m	dB(A)	78	79	76	79
<b>Unit + option 15LS</b>					
Sound power <sup>(1)</sup>	dB(A)	94	95	97	99
Sound pressure at 10 m <sup>(2)</sup>	dB(A)	62	62	64	66
Sound pressure at 1m	dB(A)	74	74	75	77
<b>Fans</b>					
Quantity		6	10	14	14
Maximum total air flow + option 15LS	l/s	31800	53000	74200	74200
Maximum rotation speed + option 15LS	r/s	14,4	14,4	14,4	14,4

(1) In dB ref=10<sup>-12</sup> W, 'A' weighted. Declared dual-number noise emission values in accordance with ISO 4871 with an associated uncertainty of +/-3dB(A). Measured in accordance with ISO 9614-1 and certified by Eurovent.

(2) In dB ref 20µPa, 'A' weighted. Declared dual-number noise emission values in accordance with ISO 4871 with an associated uncertainty of +/-3dB(A). For information, calculated from the sound power Lw(A).



Eurovent certified values

## ELECTRICAL DATA

### Electrical data - Standard units

30KAV-ZE		350A	400A	450A	500A	550A	600A	650A	750A	800A	900A	1000A	1100A	1200A	1300A
<b>Power circuit supply</b>															
Nominal voltage	V-ph-Hz	400-3-50													
Voltage range	V	360-440													
<b>Control circuit supply</b>		24 V via internal transformer													
<b>Maximum operating input power<sup>(1)</sup></b>															
Standard unit	kW	176	192	214	232	252	288	316	353	380	418	459	499	550	608
<b>Power factor at maximum power<sup>(1) (2)</sup></b>		0,91-0,93													
Displacement Power Factor (Cos Phi)		>0,98													
Total harmonic distortion (THDi) <sup>(1) (3)</sup>		35-45%													
<b>Maximum operating current draw (Un)<sup>(1)</sup></b>															
Standard unit	A	274	298	333	361	391	447	491	549	591	649	713	775	854	945
<b>Maximum operating current draw (Un-10%)<sup>(1)</sup></b>															
Standard unit	A	299	325	363	384	416	484	522	585	629	709	778	825	919	1006
<b>Start-up current<sup>(4)</sup></b>															
Standard unit	A	175	186	203	217	232	300	327	320	340	399	430	461	535	544

(1) Values obtained at operation with maximum operating power input (data given on the unit nameplate)

(2) Value decreases when load lowers

(3) May vary according to the installation's short circuit ratio

THDi increases when load lowers. But the highest impact on the installation occurs when the current is maximum. Therefore compliance of the installation regarding voltage harmonic distortion at PCC (per IEC61000-2-4 or other standard) shall be usually checked at max load in order to cover all load conditions

(4) Operating current of the biggest compressor + fan current + starting current of the smallest compressor. Starting current values used for the compressor are : 06ZCE1-H3AA06013 = 40A ; 06ZFC2-3AA06013 = 50A ; 06ZJG3-3AA06013 = 80A.

### Electrical data - Units + option 16

30KAV-ZE		350A	400A	450A	500A	550A	600A	650A	750A	800A	900A	1000A	1100A	1200A	1300A
<b>Maximum operating input power<sup>(1)</sup></b>															
Unit + option 16	kW	187	204	226	246	268	307	337	377	406	444	487	529	581	640
<b>Maximum operating current draw (Un)<sup>(1)</sup></b>															
Unit + option 16	A	291	317	352	382	416	476	524	586	631	689	756	822	902	995
<b>Maximum operating current draw (Un-10%)<sup>(1)</sup></b>															
Unit + option 16	A	318	346	385	407	443	515	557	624	672	753	825	874	971	1060

(1) Values obtained at operation with maximum operating power input (data given on the unit nameplate)

## ELECTRICAL DATA

Electrical data - Units with combination of options High energy efficiency (119), Permanent magnet motor (329), EC motor (17)

30KAV-ZE + option 119		350A	400A	450A	500A	550A	600A	650A	750A	800A
<b>Power circuit supply</b>										
Nominal voltage	V-ph-Hz	400-3-50								
Voltage range	V	360-440								
<b>Control circuit supply</b>										
24 V via internal transformer										
<b>Maximum unit power input<sup>(1)</sup></b>										
Unit + option 119	kW	177	197	209	226	245	284	306	347	368
Unit + option 119 + option 17	kW	175	195	206	223	242	281	302	343	363
Unit + option 329	kW	173	189	204	222	247	278	309	342	370
Unit + option 329 + option 119	kW	174	194	199	216	240	274	299	336	358
<b>Power factor at maximum power<sup>(1) (2)</sup></b>										
0,91-0,93										
Displacement Power Factor (Cos Phi)										
>0,98										
Total harmonic distortion (THDi) <sup>(1) (3)</sup>										
%										
35-45%										
<b>Maximum operating current draw (Un)<sup>(1)</sup></b>										
Unit + option 119	A	276	305	325	351	380	441	476	539	572
Unit + option 119 + option 17	A	273	302	321	347	375	436	470	533	565
Unit + option 329	A	269	294	318	346	384	432	480	532	576
Unit + option 329 + option 119	A	271	301	310	336	373	426	465	522	557
<b>Maximum operating current draw (Un-10%)<sup>(1)</sup></b>										
Unit + option 119	A	299	324	353	373	404	476	505	573	608
Unit + option 119 + option 17	A	296	321	349	369	399	471	499	567	601
Unit + option 329	A	294	321	348	369	409	469	511	568	614
Unit + option 329 + option 119	A	294	320	338	358	397	461	494	556	593
<b>Start-up current<sup>(4)</sup></b>										
Unit + option 119	A	175	189	199	212	226	296	319	314	330
Unit + option 119 + option 17	A	174	187	197	210	224	294	316	311	326
Unit + option 329	A	160	168	191	205	223	278	316	293	327

(1) Values obtained at operation with maximum operating power input (data given on the unit nameplate)

(2) Value decreases when load lowers

(3) May vary according to the installation's short circuit ratio

THDi increases when load lowers. But the highest impact on the installation occurs when the current is maximum. Therefore compliance of the installation regarding voltage harmonic distortion at PCC (per IEC61000-2-4 or other standard) shall be usually checked at max load in order to cover all load conditions.

(4) Operating current of the biggest compressor + fan current + starting current of the smallest compressor. Starting current values used for the compressor are : 06ZCE1-H3AA06013 = 40A ; 06ZFC2-3AA06013 = 50A ; 06ZJG3-3AA06013 = 80A.

## ELECTRICAL DATA

Electrical data - Units with combination of options High energy efficiency (119), Permanent magnet motor (329), EC motor (17)

30KAV-ZE + option 119		900A	1000A	1100A	1200A	1300A
<b>Power circuit supply</b>						
Nominal voltage	V-ph-Hz	400-3-50				
Voltage range	V	360-440				
<b>Control circuit supply</b>						
24 V via internal transformer						
<b>Maximum unit power input<sup>(1)</sup></b>						
Unit + option 119	kW	408	447	480	-	-
Unit + option 119 + option 17	kW	403	442	475	-	-
Unit + option 329	kW	-	-	-	-	-
Unit + option 329 + option 119	kW	-	-	-	-	-
<b>Power factor at maximum power<sup>(1) (2)</sup></b>						
0,91-0,93						
Displacement Power Factor (Cos Phi)						
>0,98						
Total harmonic distortion (THDi) <sup>(1) (3)</sup>						
35-45%						
<b>Maximum operating current draw (Un)<sup>(1)</sup></b>						
Unit + option 119	A	634	694	746	-	-
Unit + option 119 + option 17	A	627	687	738	-	-
Unit + option 329	A	-	-	-	-	-
Unit + option 329 + option 119	A	-	-	-	-	-
<b>Maximum operating current draw (Un-10%)<sup>(1)</sup></b>						
Unit + option 119	A	691	756	794	-	-
Unit + option 119 + option 17	A	684	749	786	-	-
Unit + option 329	A	-	-	-	-	-
Unit + option 329 + option 119	A	-	-	-	-	-
<b>Start-up current<sup>(4)</sup></b>						
Unit + option 119	A	391	420	446	-	-
Unit + option 119 + option 17	A	388	417	442	-	-
Unit + option 329	A	-	-	-	-	-

(1) Values obtained at operation with maximum operating power input (data given on the unit nameplate)

(2) Value decreases when load lowers

(3) May vary according to the installation's short circuit ratio

THDi increases when load lowers. But the highest impact on the installation occurs when the current is maximum. Therefore compliance of the installation regarding voltage harmonic distortion at PCC (per IEC61000-2-4 or other standard) shall be usually checked at max load in order to cover all load conditions.

(4) Operating current of the biggest compressor + fan current + starting current of the smallest compressor. Starting current values used for the compressor are : 06ZCE1-H3AA06013 = 40A ; 06ZFC2-3AA06013 = 50A ; 06ZJG3-3AA06013 = 80A.



## ELECTRICAL DATA

Electrical data - Units with combination of options High energy efficiency (119), compressor with PM motor (329), fans with EC motor (17) and 30KAVPZE units

30KAV-ZE + option 119		0350A	0400A	0450A	0500A	0550A	0600A	0650A
<b>Maximum operating input power<sup>(1)</sup></b>								
Unit + option 119 + option 16	kW	188	209	221	240	261	303	327
Unit + option 119 + option 17 + option 16	kW	186	207	218	237	258	300	323
Unit + option 329 + option 16	kW	184	201	216	236	263	297	330
Unit + option 329 + option 119 + option 16	kW	185	206	211	230	256	293	320
<b>Maximum operating current draw (Un)<sup>(1)</sup></b>								
Unit + option 119 + option 16		293	324	344	372	405	470	509
Unit + option 119 + option 17 + option 16	A	290	321	340	368	400	465	503
Unit + option 329 + option 16	A	286	313	337	367	409	461	513
Unit + option 329 + option 119 + option 16	A	288	320	329	357	398	455	498
<b>Maximum operating current draw (Un-10%)<sup>(1)</sup></b>								
Unit + option 119 + option 16	A	318	345	375	396	431	507	540
Unit + option 119 + option 17 + option 16	A	313	341	360	381	424	492	529
Unit + option 329 + option 16	A	313	342	370	392	436	500	546
Unit + option 329 + option 119 + option 16	A	313	341	360	381	424	492	529

30KAV-ZE + option 119		0750A	0800A	0900A	1000A	1100A	1200A	1300A
<b>Maximum operating input power<sup>(1)</sup></b>								
Unit + option 119 + option 16	kW	371	394	434	475	510	-	-
Unit + option 119 + option 17 + option 16	kW	367	389	429	470	505	-	-
Unit + option 329 + option 16	kW	366	396	-	-	-	-	-
Unit + option 329 + option 119 + option 16	kW	360	384	-	-	-	-	-
<b>Maximum operating current draw (Un)<sup>(1)</sup></b>								
Unit + option 119 + option 16		576	612	674	737	793	-	-
Unit + option 119 + option 17 + option 16	A	570	605	667	730	785	-	-
Unit + option 329 + option 16	A	569	616	-	-	-	-	-
Unit + option 329 + option 119 + option 16	A	559	597	-	-	-	-	-
<b>Maximum operating current draw (Un-10%)<sup>(1)</sup></b>								
Unit + option 119 + option 16	A	612	651	735	803	843	-	-
Unit + option 119 + option 17 + option 16	A	595	636	721	788	824	-	-
Unit + option 329 + option 16	A	607	657	-	-	-	-	-
Unit + option 329 + option 119 + option 16	A	595	636	-	-	-	-	-

(1) Values obtained at operation with maximum operating power input (data given on the unit nameplate)

## ELECTRICAL DATA

### Electrical data - 30KAVPZE

30KAVPZE		350A	400A	450A	500A	550A	600A	650A	750A	800A
<b>Power circuit supply</b>										
Nominal voltage	V-ph-Hz	400-3-50								
Voltage range	V	360-440								
<b>Control circuit supply</b>										
24 V via internal transformer										
<b>Maximum operating input power<sup>(1)</sup></b>										
Standard unit	kW	172	192	196	213	237	271	295	332	353
<b>Power factor at maximum power<sup>(1) (2)</sup></b>										
0,91-0,93										
Displacement Power Factor (Cos Phi)										
>0,98										
Total harmonic distortion (THDi) <sup>(1) (3)</sup>										
%										
35-45%										
<b>Maximum operating current draw (Un)<sup>(1)</sup></b>										
Standard unit	A	268	298	306	332	368	421	459	516	550
<b>Maximum operating current draw (Un-10%)<sup>(1)</sup></b>										
Standard unit	A	291	317	334	354	392	456	488	550	586
<b>Start-up current<sup>(4)</sup></b>										
Standard unit	A	173	188	193	206	228	287	320	306	334

(1) Values obtained at operation with maximum operating power input (data given on the unit nameplate)

(2) Value decreases when load lowers

(3) May vary according to the installation's short circuit ratio

THDi increases when load lowers. But the highest impact on the installation occurs when the current is maximum. Therefore compliance of the installation regarding voltage harmonic distortion at PCC (per IEC61000-2-4 or other standard) shall be usually checked at max load in order to cover all load conditions.

(4) Operating current of the biggest compressor + fan current + starting current of the smallest compressor. Starting current values used for the compressor are : 06ZCE1-H3AA06013 = 40A ; 06ZFC2-3AA06013 = 50A ; 06ZJG3-3AA06013 = 80A.

### Electrical data - 30KAVPZE units + option 16

30KAVPZE		0350A	0400A	0450A	0500A	0550A	0600A	0650A	0750A	0800A
<b>Maximum operating input power<sup>(1)</sup></b>										
Unit + option 16	kW	183	204	208	227	253	290	316	356	379
<b>Maximum operating current draw (Un)<sup>(1)</sup></b>										
Unit + option 16	A	285	317	325	353	393	450	492	553	590
<b>Maximum operating current draw (Un-10%)<sup>(1)</sup></b>										
Unit + option 16	A	310	338	356	377	419	487	523	589	629

(1) Values obtained at operation with maximum operating power input (data given on the unit nameplate)

### Electrical data - 30KAVIZE

30KAVIZE		500	800	1100	1250
<b>Power circuit supply</b>					
Nominal voltage	V-ph-Hz	400-3-50			
Voltage range	V	360-440			
<b>Control circuit supply</b>					
24 V via internal transformer					
<b>Maximum operating input power<sup>(1)</sup></b>					
Standard unit	kW	261	404	520	626
<b>Power factor at maximum power<sup>(1) (2)</sup></b>					
0,91-0,93					
Displacement Power Factor (Cos Phi)					
>0,98					
Total harmonic distortion (THDi) <sup>(1) (3)</sup>					
%					
35-45					
<b>Maximum operating current draw (Un)<sup>(1)</sup></b>					
Standard unit	A	405	628	808	973
<b>Maximum operating current draw (Un-10%)<sup>(1)</sup></b>					
Standard unit	A	430	668	860	1038
<b>Start-up current<sup>(4)</sup></b>					
Standard unit	A	239	249	477	558

(1) Values obtained at operation with maximum operating power input (data given on the unit nameplate)

(2) Value decreases when load lowers

(3) May vary according to the installation's short circuit ratio

THDi increases when load lowers. But the highest impact on the installation occurs when the current is maximum. Therefore compliance of the installation regarding voltage harmonic distortion at PCC (per IEC61000-2-4 or other standard) shall be usually checked at max load in order to cover all load conditions.

(4) Operating current of the biggest compressor + fan current + starting current of the smallest compressor. Starting current values used for the compressor are : 06ZCE1-H3AA06013 = 40A ; 06ZFC2-3AA06013 = 50A ; 06ZJG3-3AA06013 = 80A.

## ELECTRICAL DATA

### Compressor electrical data

Compressor	I Max (A) <sup>(1)</sup> Standard	I Max (A) <sup>(1)</sup> Option 16	F max (Hz) <sup>(2)</sup>	Inverter type <sup>(3)</sup>
06ZCE1H3AA06013	146	156	82	D3h
06ZCE1T3AA06013	184	195	105	D3h
06ZFC2T3AA06013	280	301	95	D3h/D4h
06ZJG3H3AA06013	370	392	77	D4h
06ZJG3T3AA06013	452	478	95	D4h
06ZCEAT3AA06013	169	180	103	D3h
06ZFCBT3AA06013	258	277	93	D3h

(1) Maximum compressor operating current draw over the entire range when powered at rated voltage. May be lower depending on the unit size.

(2) Maximum compressor frequency other the entire range. This frequency can be limited to a lower value depending on the unit size.

(3) Mechanical inverter type : defines inverter weight and dimensions.

### Distribution of compressors per circuit

30KAV-ZE	Circuit	350A	400A	450A	500A	550A	600A	650A	750A	800A	900A	1000A	1100A	1200A	1300A
06ZCE1H3AA06013	A	1	1	-	-	-	-	-	-	-	-	-	-	-	-
	B	1	1	-	-	-	-	-	-	-	-	-	-	-	-
06ZCE1T3AA06013	A	-	-	1	1	1	-	-	-	-	-	-	-	-	-
	B	-	-	1	1	1	1	1	-	-	-	-	-	-	-
06ZFC2T3AA06013	A	-	-	-	-	-	1	1	1	1	-	-	-	-	-
	B	-	-	-	-	-	-	-	1	1	-	-	-	-	-
06ZJG3H3AA06013	A	-	-	-	-	-	-	-	-	-	1	1	1	1	-
	B	-	-	-	-	-	-	-	-	-	1	1	1	-	-
06ZJG3T3AA06013	A	-	-	-	-	-	-	-	-	-	-	-	-	-	1
	B	-	-	-	-	-	-	-	-	-	-	-	-	1	1

30KAVPZE	Circuit	350A	400A	450A	500A	550A	600A	650A	750A	800A
06ZCEAT3AA06013	A	1	1	1	1	1	-	-	-	-
	B	1	1	1	1	1	1	1	-	-
06ZFCBT3AA06013	A	-	-	-	-	-	1	1	1	1
	B	-	-	-	-	-	-	-	1	1

30KAVIZE	Circuit	500	800	1100	1250
06ZCE1H3AA06013	A	1	-	-	-
	B	1	-	-	-
06ZFC2T3AA06013	A	-	1	-	-
	B	-	1	-	-
06ZJG3H3AA06013	A	-	-	1	-
	B	-	-	1	-
06ZJG3T3AA06013	A	-	-	-	1
	B	-	-	-	1

## DIMENSIONS/CLEARANCES

### 30KAV-ZE 350A & 400A ; 30KAVIZE 500; without hydraulic module

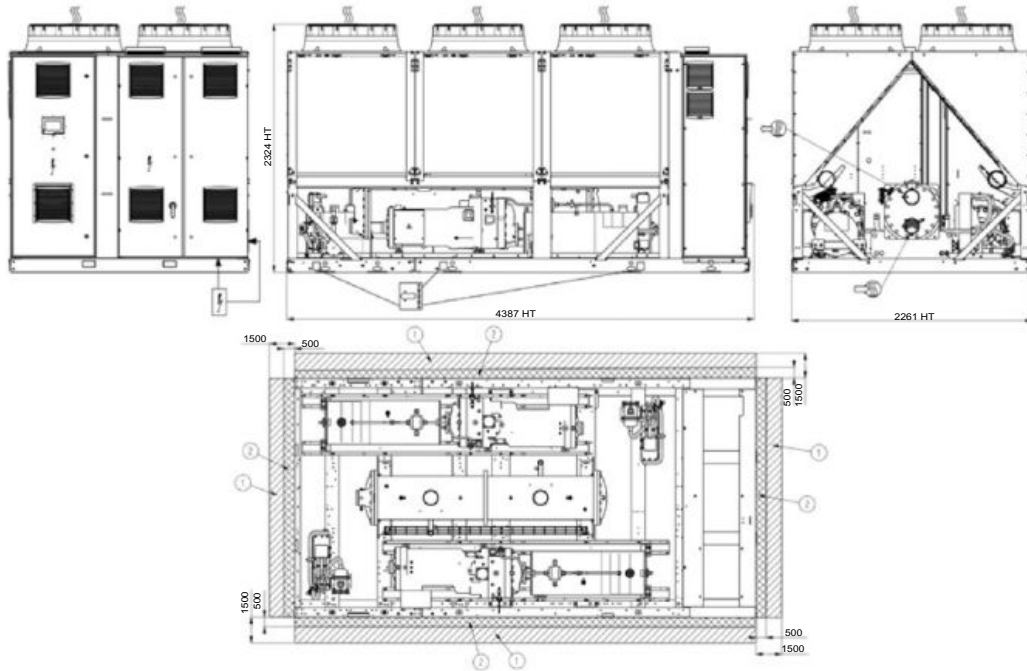

### 30KAV-ZE 350A & 400A with Hydraulic module

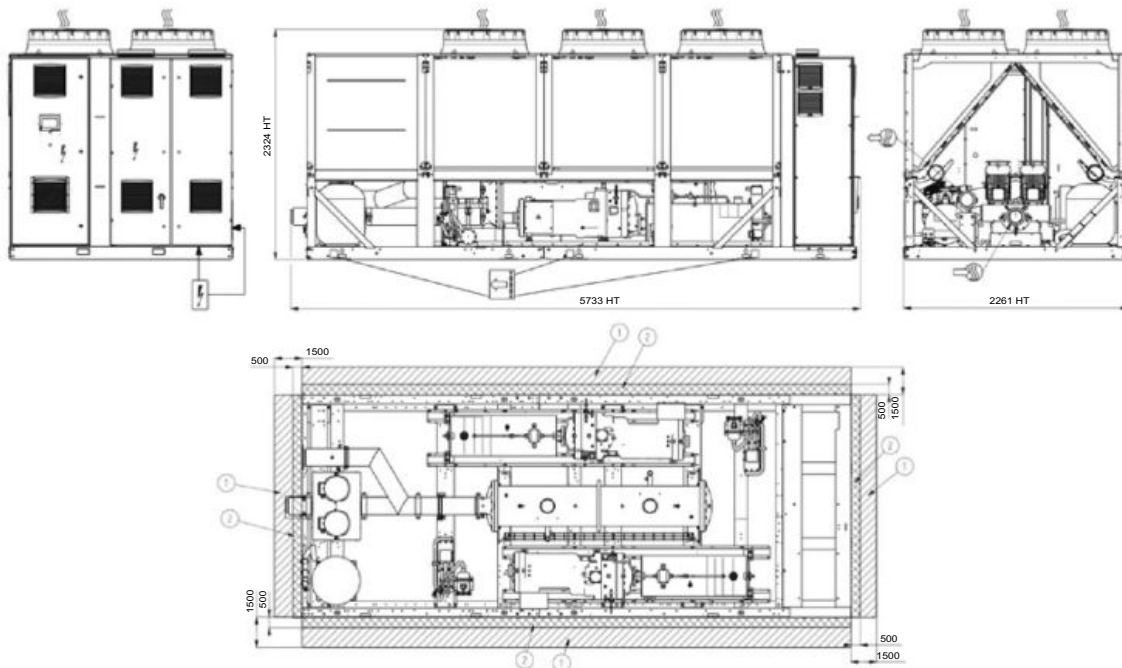

#### Legend

All dimensions are given in mm.

① Required clearances for maintenance (see note)

② Potentially flammable zone around the machine

Water inlet for standard unit

Water outlet for standard unit

Air outlet – do not obstruct

Power electrical connection

#### NOTES:

**Drawings are not contractually binding.**

**Before designing an installation, consult the certified dimensional drawings, available on request.**

**For the positioning of the fixing points, weight distribution and centre of gravity coordinates please refer to the dimensional drawings.**

**If any unit(s) are close to walls, please refer to chapter “Distance to the wall” of this document to determine the space required.**

## DIMENSIONS/CLEARANCES

### 30KAV-ZE 450A & 500A, without hydraulic module

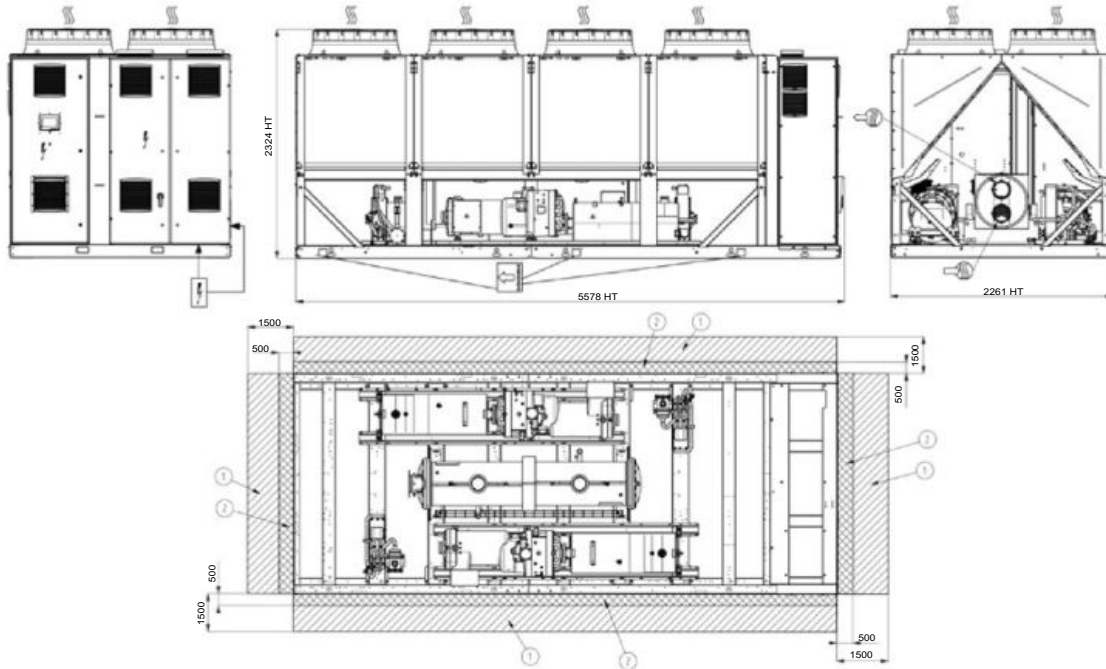

### 30KAV-ZE 450A & 500A with Hydraulic module

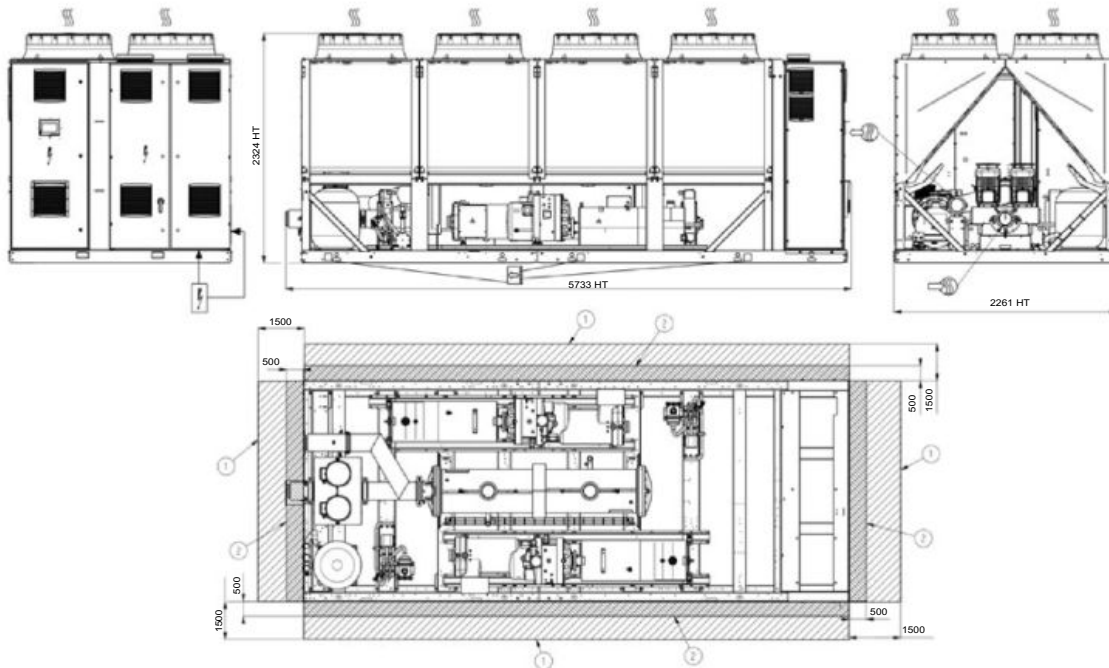

#### Legend

All dimensions are given in mm.

- ① Required clearances for maintenance (see note)
- ② Potentially flammable zone around the machine
- Water inlet for standard unit
- Water outlet for standard unit
- Air outlet – do not obstruct
- Power electrical connection

#### NOTES:

**Drawings are not contractually binding.**

**Before designing an installation, consult the certified dimensional drawings, available on request.**

**For the positioning of the fixing points, weight distribution and centre of gravity coordinates please refer to the dimensional drawings.**

**If any unit(s) are close to walls, please refer to chapter “Distance to the wall” of this document to determine the space required.**



## DIMENSIONS/CLEARANCES

30KAV-ZE 550A & 600A ; 30KAV-ZE 350A, 400A, 450A, 500A - opt 119 ; 30KAVPZE 350A, 400A, 450A, 500A ; 30KAVIZE 800 ; without hydraulic module

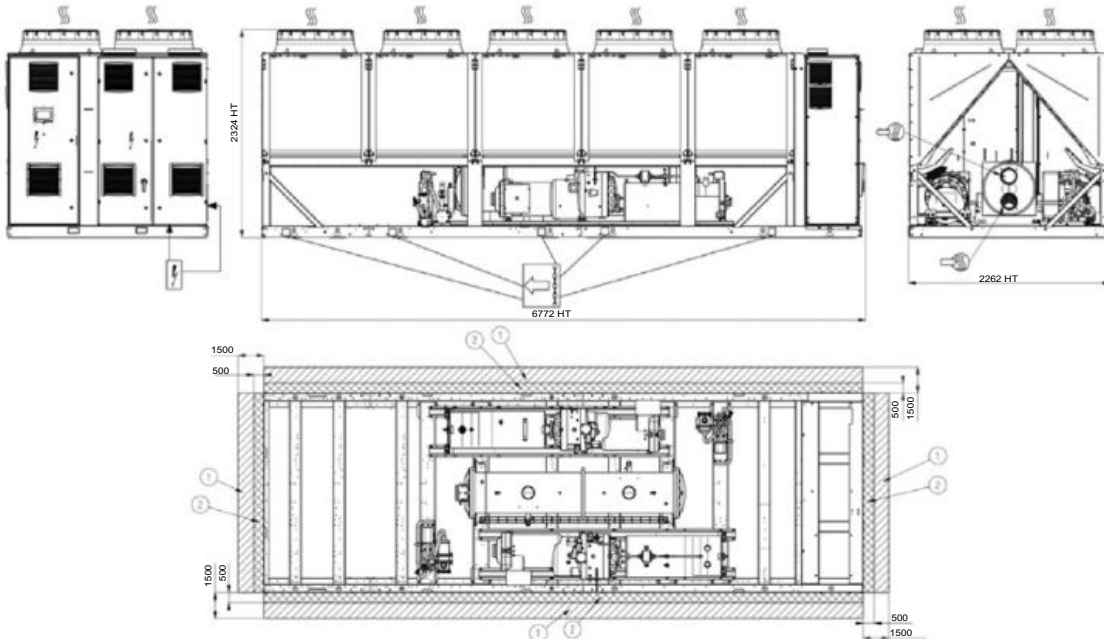

30KAV-ZE 550A & 600A ; 30KAV-ZE 350A, 400A, 450A, 500A - opt 119 ; 30KAVPZE 350A, 400A, 450A, 500A ; 30KAVIZE 800 ; with hydraulic module

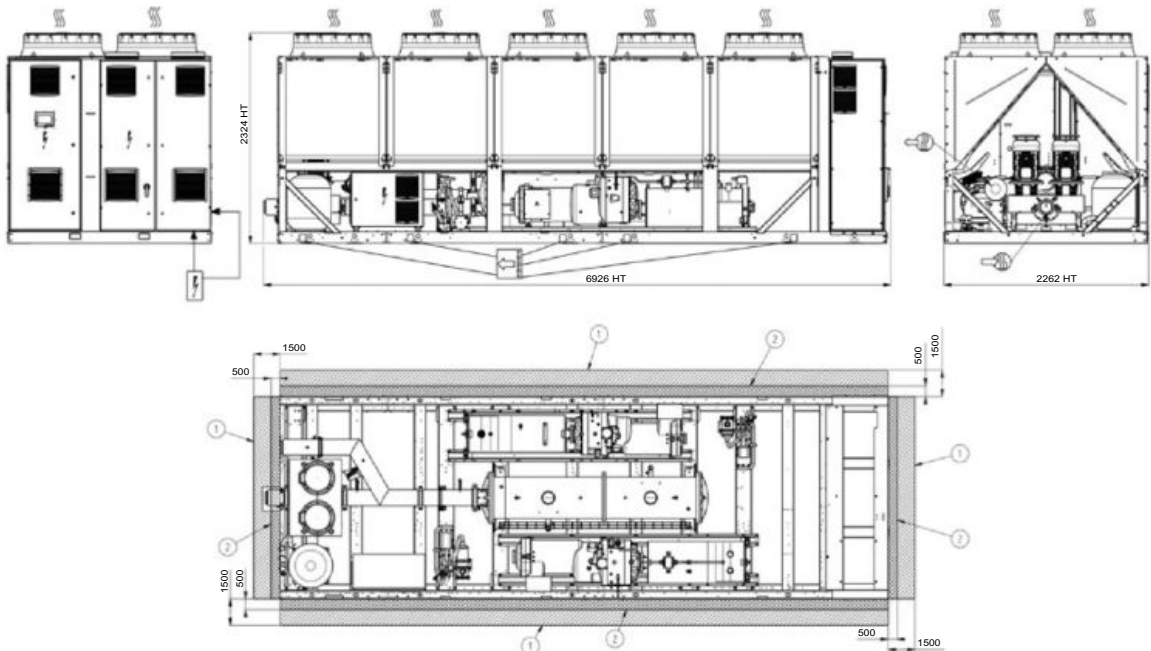

### Legend

All dimensions are given in mm.

- ① Required clearances for maintenance (see note)
- ② Potentially flammable zone around the machine
- Water inlet for standard unit
- Water outlet for standard unit
- Air outlet – do not obstruct
- Power electrical connection

### NOTES:

Drawings are not contractually binding.

Before designing an installation, consult the certified dimensional drawings, available on request.

For the positioning of the fixing points, weight distribution and centre of gravity coordinates please refer to the dimensional drawings.

If any unit(s) are close to walls, please refer to chapter "Distance to the wall" of this document to determine the space required.

## DIMENSIONS/CLEARANCES

### 30KAV-ZE 650A & 750A ; 30KAV-ZE 550A - opt 119 ; 30KAVPZE 550A ; without hydraulic module

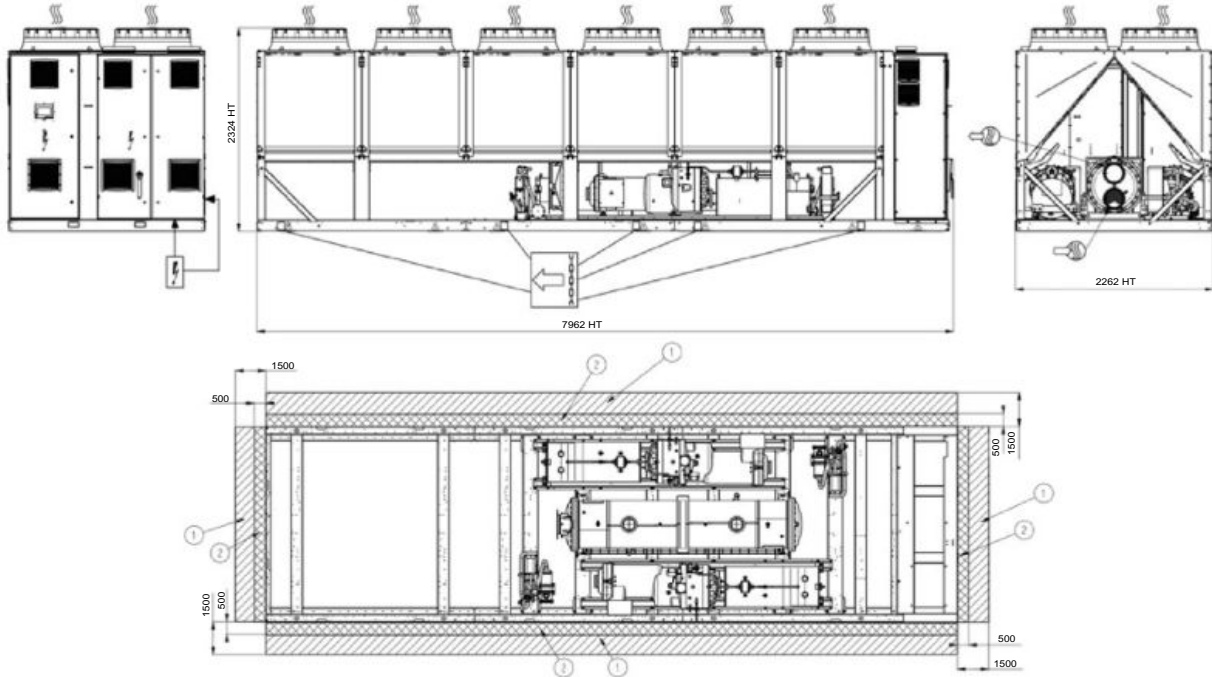

### 30KAV-ZE 550A - opt 119 ; 30KAVPZE 550A ; with hydraulic module

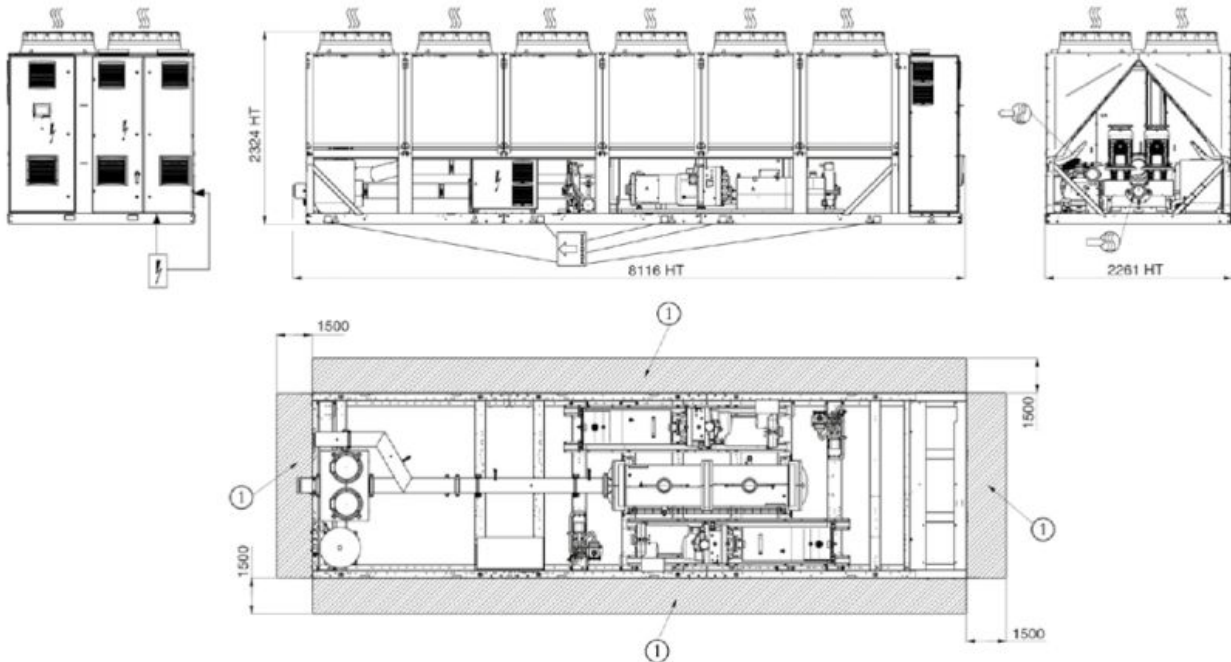

#### Legend

All dimensions are given in mm.

- ① Required clearances for maintenance (see note)
- ② Potentially flammable zone around the machine
- Water inlet for standard unit
- Water outlet for standard unit
- Air outlet – do not obstruct
- Power electrical connection

#### NOTES:

Drawings are not contractually binding.

Before designing an installation, consult the certified dimensional drawings, available on request.

For the positioning of the fixing points, weight distribution and centre of gravity coordinates please refer to the dimensional drawings.

If any unit(s) are close to walls, please refer to chapter "Distance to the wall" of this document to determine the space required.

## DIMENSIONS/CLEARANCES

30KAV-ZE 800A ; 30KAV-ZE 600A & 650A - opt 119 ; 30KAVPZE 600A & 650A ; without hydraulic module

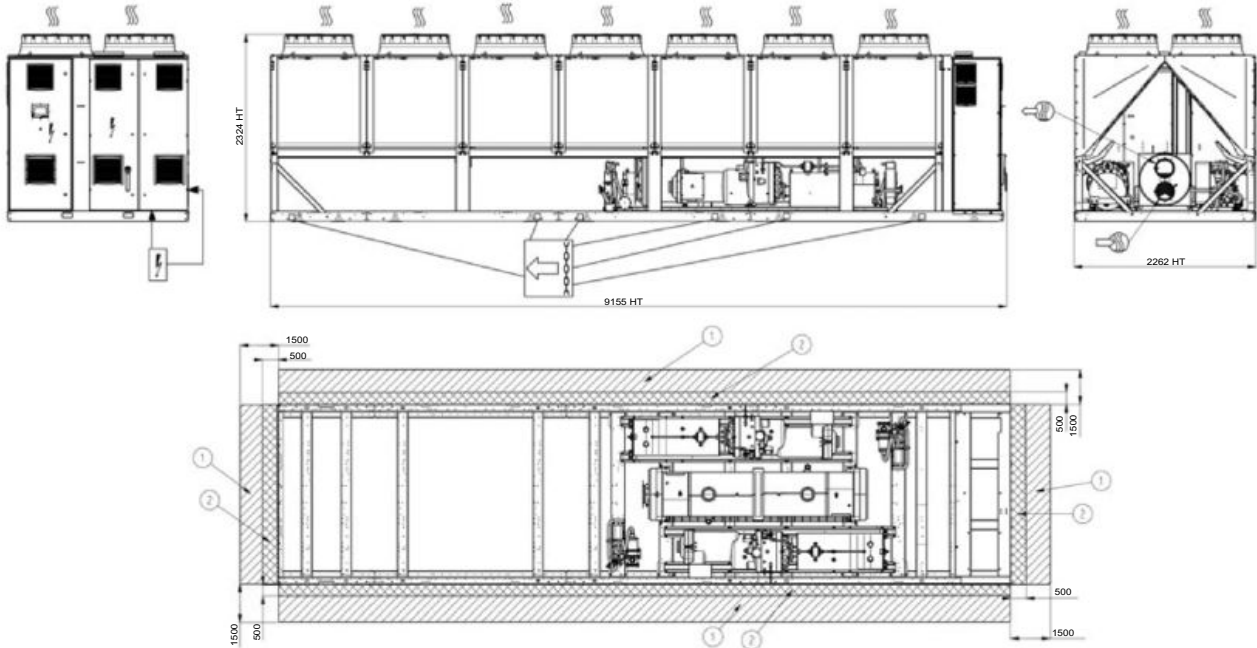

30KAV-ZE 600A- opt 119 ; 30KAVPZE 600A ; with hydraulic module

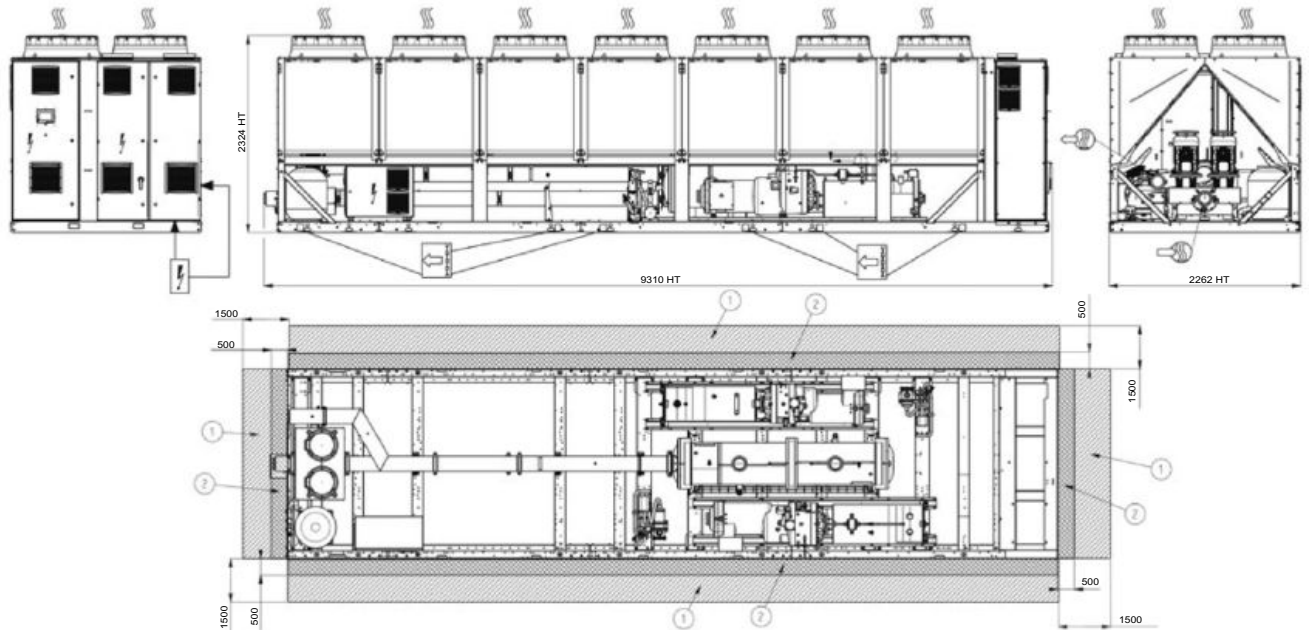

### Legend

All dimensions are given in mm.

① Required clearances for maintenance (see note)

② Potentially flammable zone around the machine

Water inlet for standard unit

Water outlet for standard unit

Air outlet – do not obstruct

Power electrical connection

### NOTES:

Drawings are not contractually binding.

Before designing an installation, consult the certified dimensional drawings, available on request.

For the positioning of the fixing points, weight distribution and centre of gravity coordinates please refer to the dimensional drawings.

If any unit(s) are close to walls, please refer to chapter “Distance to the wall” of this document to determine the space required.



## DIMENSIONS/CLEARANCES

### 30KAV-ZE 750A & 800A - opt 119 ; 30KAVPZE 750A & 800A

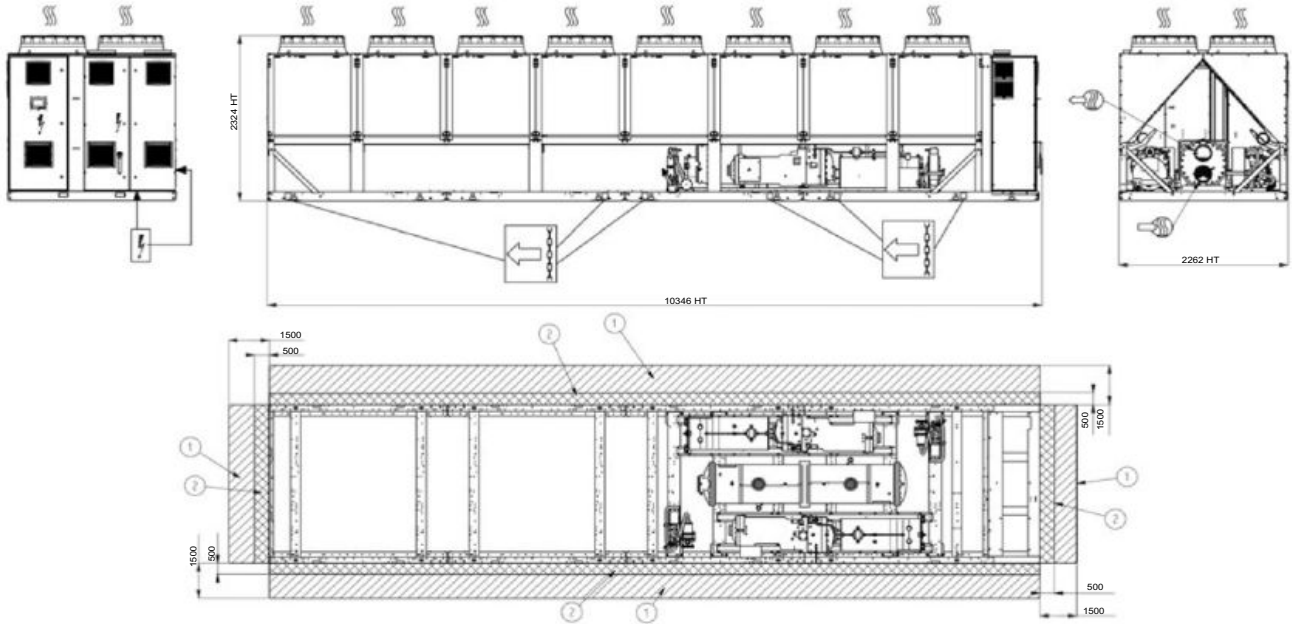

### 30KAV-ZE 900A ; 30KAVIZE 1100 ; 30KAVIZE 1250

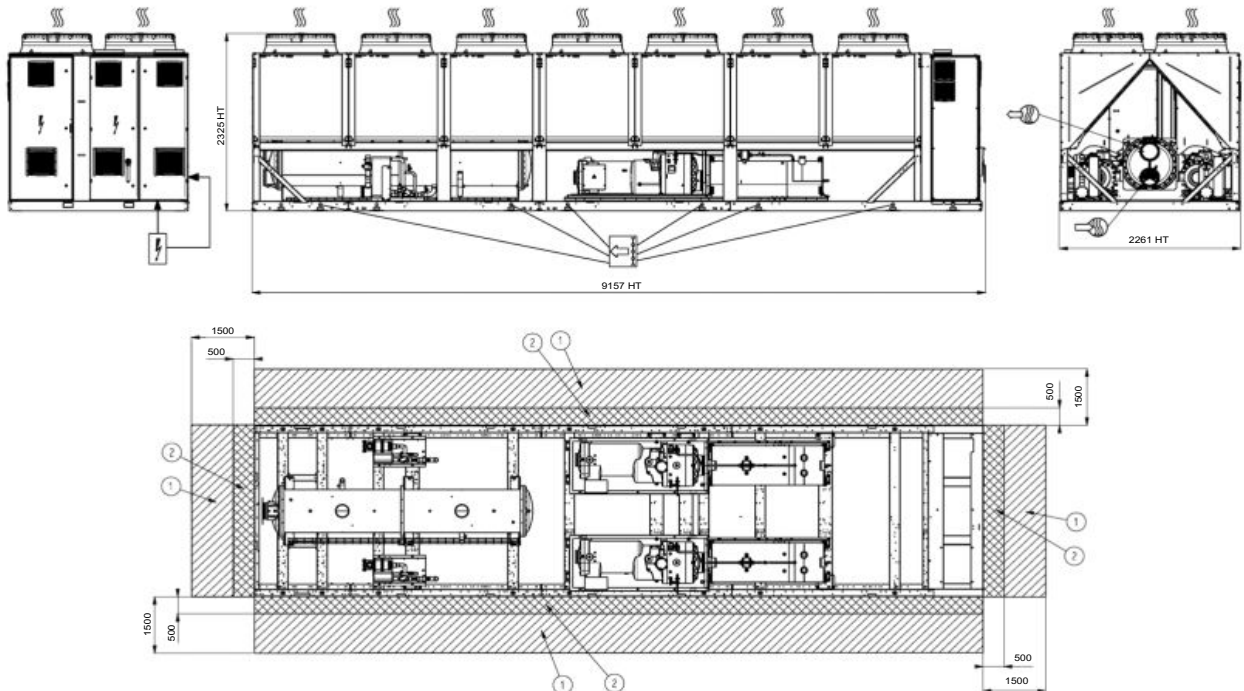

#### Legend

All dimensions are given in mm.

- ① Required clearances for maintenance (see note)
- ② Potentially flammable zone around the machine
- Water inlet for standard unit
- Water outlet for standard unit
- Air outlet – do not obstruct
- Power electrical connection

#### NOTES:

Drawings are not contractually binding.

**Before designing an installation, consult the certified dimensional drawings, available on request.**

**For the positioning of the fixing points, weight distribution and centre of gravity coordinates please refer to the dimensional drawings.**

**If any unit(s) are close to walls, please refer to chapter "Distance to the wall" of this document to determine the space required.**

## DIMENSIONS/CLEARANCES

### 30KAV-ZE 1000A

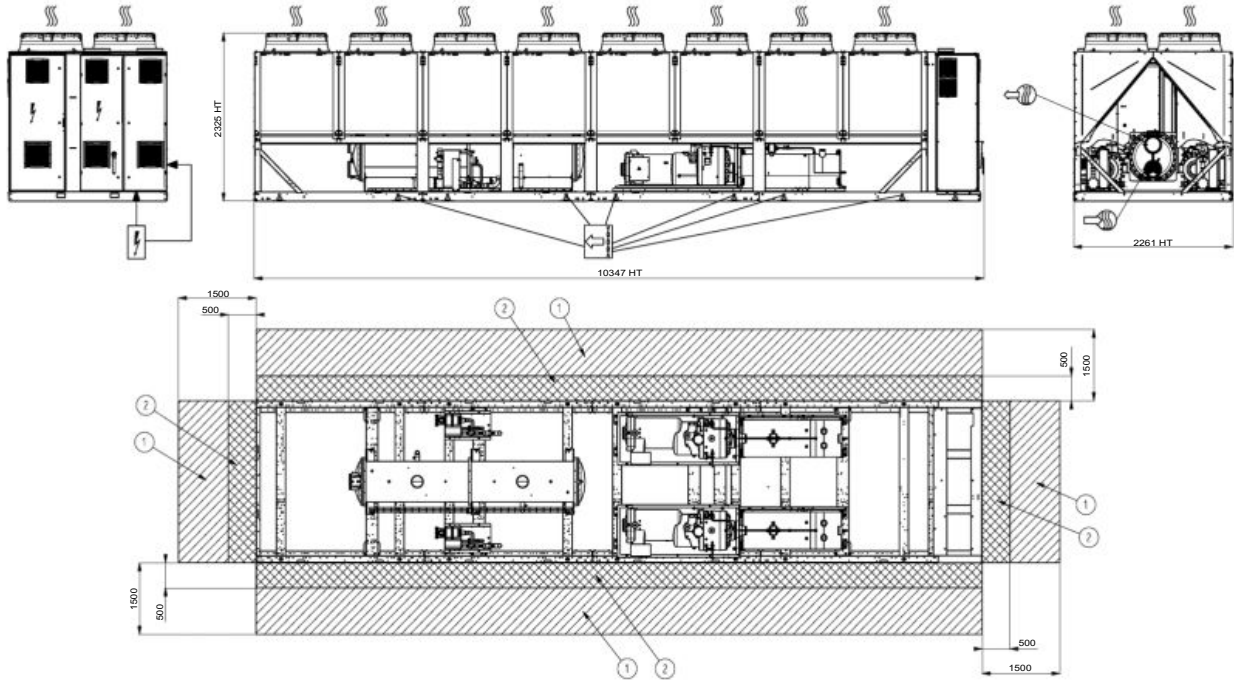

### 30KAV-ZE 1100A ; 30KAV-ZE 900A - opt 119

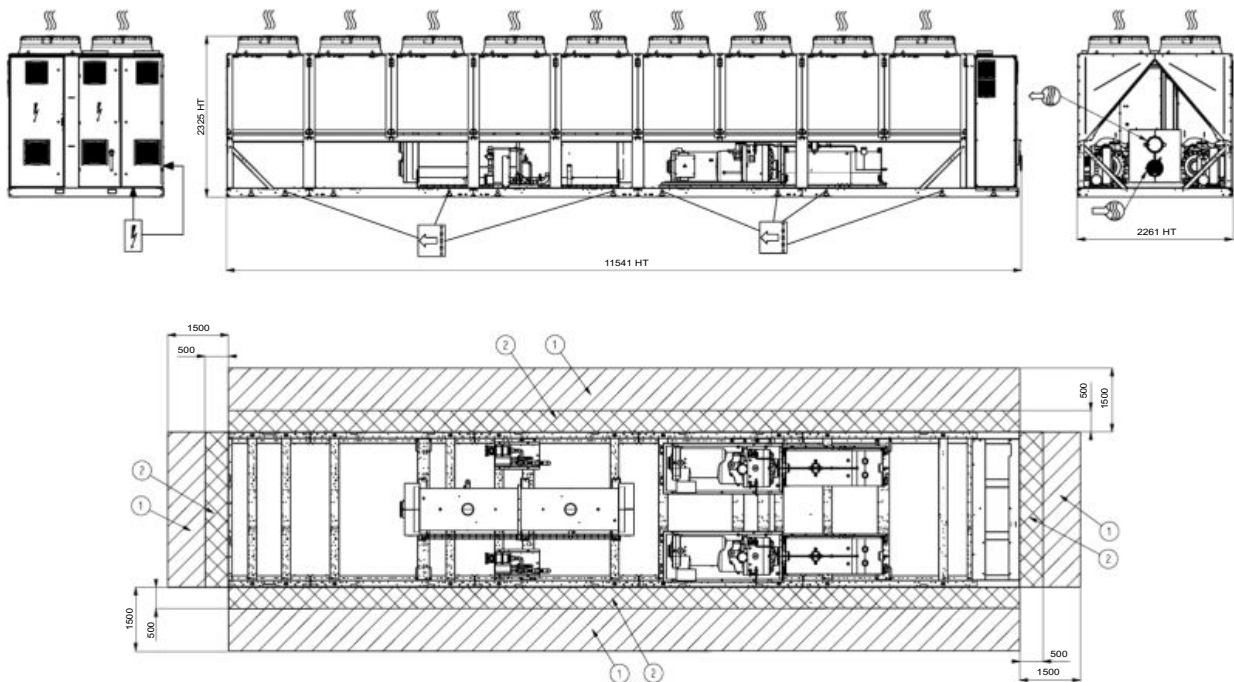

#### Legend

All dimensions are given in mm.

① Required clearances for maintenance (see note)

② Potentially flammable zone around the machine

Water inlet for standard unit

Water outlet for standard unit

Air outlet – do not obstruct

Power electrical connection

#### NOTES:

**Drawings are not contractually binding.**

**Before designing an installation, consult the certified dimensional drawings, available on request.**

**For the positioning of the fixing points, weight distribution and centre of gravity coordinates please refer to the dimensional drawings.**

**If any unit(s) are close to walls, please refer to chapter "Distance to the wall" of this document to determine the space required.**



## DIMENSIONS/CLEARANCES

### 30KAV-ZE 1200A & 1300A ; 30KAV-ZE 1000A & 1100A - opt 119

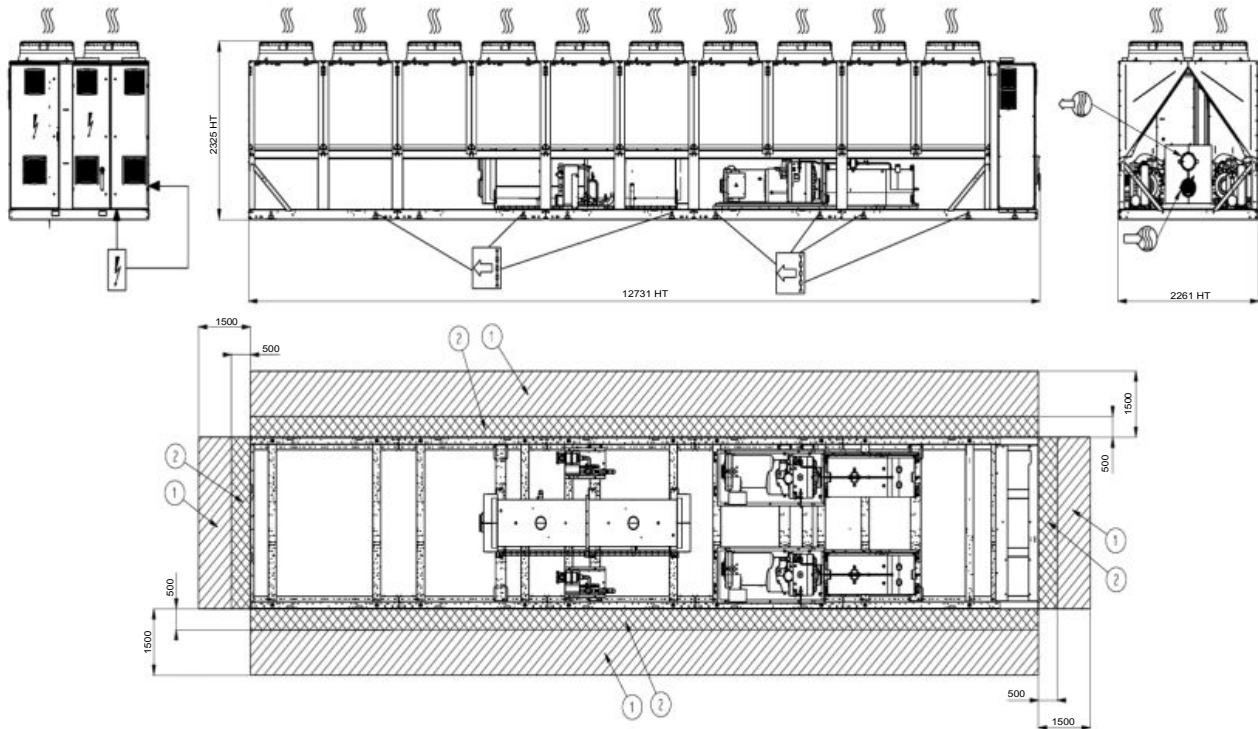

#### Legend

All dimensions are given in mm.

- ① Required clearances for maintenance (see note)
- ② Potentially flammable zone around the machine
- Water inlet for standard unit
- Water outlet for standard unit
- Air outlet – do not obstruct
- Power electrical connection

#### Multiple chiller installation

It is recommended to install multiple chillers in a single row, arranged as shown in the example below, to avoid recycling of warm air from one unit to another.



If the situation at the site does not permit this arrangement, contact your Carrier distributor to evaluate the various possible arrangements. In certain situations an accessory (supplied loose at the time of purchase) can be added.

#### NOTES:

**Drawings are not contractually binding.**

**Before designing an installation, consult the certified dimensional drawings, available on request.**

**For the positioning of the fixing points, weight distribution and centre of gravity coordinates please refer to the dimensional drawings.**

**If any unit(s) are close to walls, please refer to chapter "Distance to the wall" of this document to determine the space required.**

#### Distance to the wall

To ensure correct operation for most cases:

- If  $h < H$  (2,3 m),  $S$  minimum = 3 m
- If  $h > H$  ou  $S < 3$  m, contact your Carrier distributor to evaluate the various possible arrangements. In certain situations an accessory (supplied loose at the time of purchase) can be added.

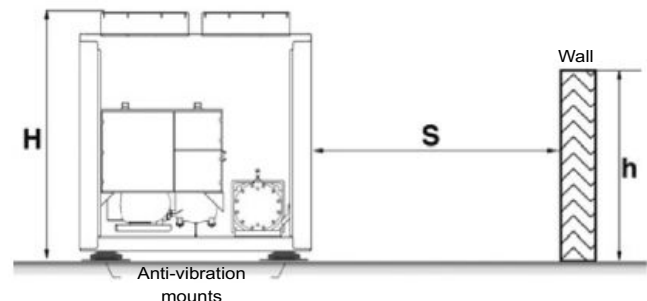



## AIR-COOLED FIXED-SPEED SCREW CHILLER



- Very economical operation
- Low sound levels
- Simple installation
- Environmentally responsible
- Exceptional reliability

30XBEZE 200 - 1200  
30XBPZE 200 - 1200

**AQUAFORCE**  
PUREtec

Nominal cooling capacity 210 - 1170 kW - 50 Hz

The AquaForce® 30XBEZE and 30XBPZE liquid chillers are the economic solution with ultra-low GWP R-1234ze refrigerant for commercial and industrial applications where high reliability and economic operation in all climate conditions are key customer requirements.

The AquaForce® 30XBEZE and 30XBPZE liquid chillers are designed to meet current and future regulations for energy efficiency and operating sound levels. They use the latest Carrier technologies:

- Refrigerant R-1234ze
- Carrier 06T twin-rotor fixed-speed screw compressors.
- Low noise 6th generation of Carrier Flying Bird™ fans with variable speed AC motor (30XBEZE) or variable speed EC motor.
- Carrier flooded shell-and-tube evaporator with new copper tube design for low pressure drops
- 2nd generation of “V” shape Carrier Novation™ microchannel heat exchangers with optional Enviro-Shield coatings.
- Carrier SmartVu™ control with color touch screen user interface that includes 10 languages.



CARRIER participates in the ECP programme for LCP-HP  
Check ongoing validity of certificate:  
[www.eurovent-certification.com](http://www.eurovent-certification.com)

## AQUAFORCE® VISION WITH PURETEC™ REFRIGERANT

### SUSTAINABILITY

PUREtec™: the environmental excellence solution

■ **GWP<1**

Carrier has selected HFO R-1234ze as the best refrigerant to replace HFC R-134a on screw chillers and heat-pumps.

HFO R-1234ze offers a **Global Warming Potential (GWP) index below 1**, similar to that of natural substances (CO<sub>2</sub> GWP=1).

■ **High efficiency**

This excellent efficiency performance in turn means a **lower total carbon footprint**, with a reduction of 10% compared to HFC R-134a and HFC/HFO R-513A refrigerants.

■ **Regulation compliance**

Carrier has made the strategic decision to choose a long-term solution for its new chiller and heat-pump ranges using screw compressors: **HFO R-1234ze, with a GWP<1, is not impacted by the F-gas Regulation.**

## AQUAFORCE® VISION THE RIGHT SOLUTION FOR EVERY APPLICATION

Carrier's AquaForce® Vision range is available in three levels of efficiency to perfectly match each customer application and meet the European Ecodesign directive requirements.

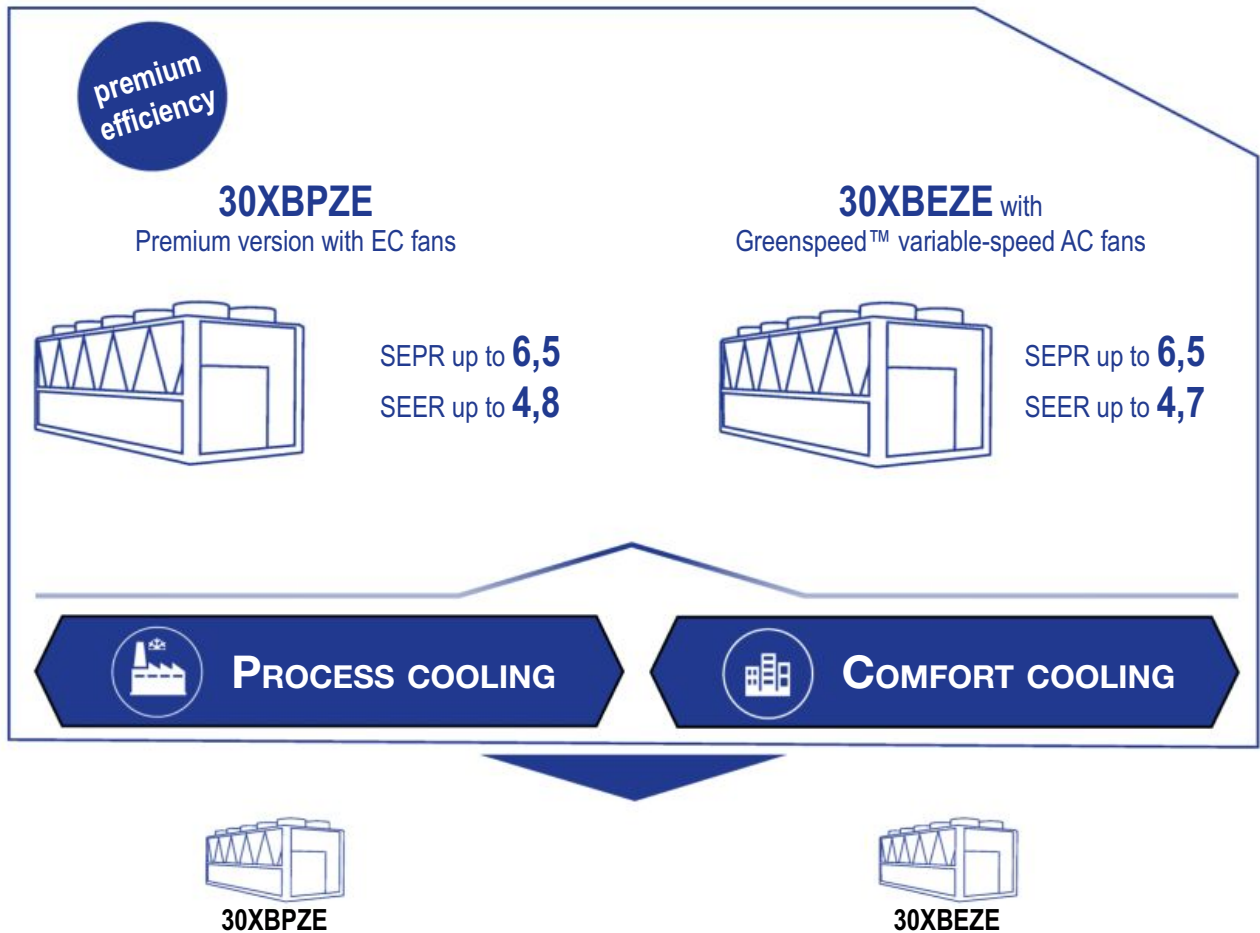

The AquaForce® 30XBPZE with Greenspeed™ intelligence is the premium version EC fans to improve both the full load and part load energy efficiency. The 30XBPZE provides very cost effective operation in both process and comfort applications through the use of state of the art EC fan technology.

The AquaForce® 30XBEZE is equipped with fixed-speed screw compressor and variable-speed AC fans motors. The 30XBEZE offers an economical solution whilst providing high full load energy efficiency level for process applications and 12/7°C operation in hot climates. 30XBEZE is compliant with the 2021 EU Ecodesign SEPR -2/-8°C and 12/7°C requirements for medium and high temperature process chillers.

## AQUAFORCE® VISION CUSTOMER BENEFITS

### ■ Outstanding performance

Equipped with fixed-speed screw compressors with EC fans and extra condensing surface, Carrier's AquaForce® Vision 30XBPZE chiller with Greenspeed™ intelligence improve both the full load and part load energy efficiency. The 30XBPZE provides very cost effective operation in both process and comfort applications through the use of state of the art EC fan technology.



SEER  
up to **4,5**

### ■ Low sound levels

The new generation of Carrier 06T fixed-speed twin screw compressor with integrated resonator array and the 6th generation of Flying Bird™ fans with new fan blade design inspired by nature help reduce compressor and airflow noise down to as little as 90 dB(A). 30XBEZE/30XBPZE is 6 dB(A) quieter than the previous AquaForce® 30XAV generation.



**90 dB(A)**

### ■ Environmentally responsible

Carrier AquaForce® Vision 30XBEZE/30XBPZE is a boost for green cities and contributes to a sustainable future. Combining a reduced load refrigerant and exceptional energy efficiency it significantly lowers energy consumption while reducing carbon dioxide emissions by 25% throughout its life cycle.



UP TO  
**25% LESS**  
CO<sub>2</sub> EMISSION

### ■ Extensive scope of application

Carrier AquaForce® Vision adapts effortlessly to a wide range of applications. Extended operating temperatures from -20°C to 55°C outdoor air temperatures and negative water temperatures make it ideal for various sectors of activity. From high-end office buildings and hotels to healthcare facilities, data centers and industrial projects, AquaForce® Vision 30XBEZE/30XBPZE meets the most demanding expectations in terms of energy efficiency and savings, whatever the climate and wherever the location.



FROM  
**-20°C**  
to **55°C**

### ■ Easy installation & maintenance

Built-in fixed-speed pumps up to 400 kW, automatic nominal water flow adjustment through electronic control, automatic unit energy performance measurement under real conditions, all these new features provide peace of mind for installers and service companies alike.



**25%**  
SMALLER



## CUSTOMER BENEFITS

The range is available in 2 efficiency levels.

### ■ 30XBEZE standard unit

The AquaForce® 30XBEZE is equipped with fixed-speed screw compressors and variable speed fans with AC motors. The 30XBEZE offers an economical solution whilst providing high full load efficiency for process applications and operation in high ambients.

(Average SEPR of 6,1, average SEER of 4,6, average EER of 3,3)

### ■ 30XBPZE premium unit

The 30XBPZE premium unit is equipped with variable speed EC fans to improve both the full load and part load energy efficiency. The 30XBPZE provides very cost effective operation in both process and comfort applications through the use of state of the art EC fan technology. (Average SEPR of 6,4, average SEER of 4,6, average EER of 3,4)

## Very economical operation

Exceptionally high full load and part load energy efficiency:

- 30XBEZE version with Eurovent energy efficiency class A, and SEER 12/7°C up to 4,7 in accordance with EN14825.
- 30XBPZE version with Eurovent energy efficiency class A, and SEER 12/7°C up to 4,8 in accordance with EN14825.
- Twin-rotor screw compressor equipped with a high-efficiency motor and a variable capacity valve that permits exact matching of the cooling capacity to the load.
- Novation™ aluminium condenser with high-efficiency micro-channels.
- Flooded shell-and-tube evaporator with new generation of cooler tubes to reduce exchanger pressure drops, especially in applications with high percentage of glycol.
- Electronic expansion device permitting operation at a lower condensing pressure and improved utilisation of the evaporator heat exchange surface (superheat control).
- Economiser system with electronic expansion device for increased cooling capacity.

## Low operating sound levels

### ■ Compressors

- Discharge dampers integrated in the oil separator (Carrier patent).
- Silencer on the economiser return line.
- Compressor and oil separator acoustic enclosure, reducing radiated noise (option).

### ■ Condenser section

- Condenser coils in wide angle V configuration, allowing quieter air flow across the coil
- Low-noise 6<sup>th</sup> generation Flying Bird fans, made of a composite material (Carrier patent), are now even quieter and do not generate intrusive low-frequency noise
- Rigid fan mounting preventing start-up noise (Carrier patent).

## CUSTOMER BENEFITS

### Simple installation

- Integrated hydraulic module (option)
  - Centrifugal low or high-pressure water pump (as required), based on the pressure loss of the hydraulic installation
  - Single or dual pump (as required) with run time balancing and automatic changeover to the back-up pump if a fault develops
  - Water filter to protect pump against circulating debris
  - High-capacity membrane expansion tank ensures pressurisation of the water circuit (option)
  - Thermal insulation and aluminium cladding (option)
  - Pressure sensor to check filter condition and for direct numerical display of the water flow rate with an estimate of the instantaneous cooling capacity at the control interface
- Simplified electrical connections
  - Main disconnect switch with high trip capacity
  - Transformer to supply the integrated control circuit (400/24 V).
- Fast commissioning
  - Systematic factory operation test before shipment
  - Quick-test function for step-by-step verification of the controls, expansion devices, fans and compressors.

### Exceptional reliability

- Screw compressors
  - Industrial-type screw compressors with oversized bearings and motor cooled by suction gas.
  - All compressor components are easily accessible on site minimising down-time.
  - Dedicated electronic compressor protection module.
- Air condenser
  - 2<sup>nd</sup> generation of "V" shape Carrier Novation™ aluminium microchannel heat exchangers (MCHE) with high corrosion resistance. The all aluminium design eliminates the formation of galvanic currents between aluminium and copper that cause coil corrosion in saline or corrosive environments.
- Evaporator
  - Thermal insulation with aluminium sheet finish (option) for improved resistance to mechanical and UV damage.
- Auto-adaptive control
  - Control algorithm prevents excessive compressor cycling (Carrier patent)
  - Automatic compressor unloading in case of abnormally high condensing pressure. If condenser coil fouling or fan failure occurs, the AquaForce® continues to operate, but at reduced capacity
- Exceptional endurance tests
  - Partnerships with specialised laboratories and use of sophisticated finite element stress analysis for the design of critical components.
  - Transport simulation test in the laboratory on a vibrating table. The test is based on a military standard and equivalent to 4000 km by truck.
  - Salt mist corrosion resistance test in the laboratory for increased corrosion resistance.

## 30XBEZE AND 30XBPZE TECHNICAL INSIGHTS

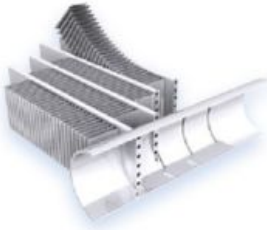

### 3<sup>RD</sup> GENERATION OF NOVATION<sup>®</sup> MICRO CHANNEL HEAT EXCHANGERS

- Exclusive Carrier design
- Increased reliability with new aluminum alloy
- Significantly reduces refrigerant charge (-40% vs cu/al coils)
- Enviro-shield<sup>™</sup> coating for mildly corrosive environments
- Super Enviro-shield<sup>™</sup> coating for highly corrosive environments (industry or marine applications)
- Easy cleaning with high pressure air or water washer

### ADVANCED SMARTVU<sup>™</sup> WITH 7 INCH COLOR TOUCH SCREEN INTERFACE

- Exclusive Carrier design
- 10 languages available: DE, EN, ES, FR, IT, NL, PT, TR, TU + one additional customer choice
- Touch screen user interface
- BACnet, J-Bus or LON communication interfaces
- Optional wireless connectivity

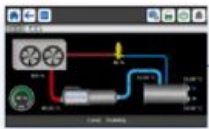

- Remote monitoring with Carrier Connect

### FLOODED SHELL AND TUBE EVAPORATOR

- Exclusive Carrier design
- Flooded technology for high energy efficiency
- New generation of copper tubes with specific profile to reduce pressure drops when operating with glycol



### 6<sup>TH</sup> GENERATION OF VARIABLE-SPEED FLYING BIRD<sup>™</sup> FANS WITH AC OR EC MOTOR

- Exclusive Carrier design
- Fan blade design inspired by nature
- AC motor technology
- High efficiency version with EC motor technology (option and 30XBPZE).



### FIXED-SPEED DUAL PUMPS WITH AC MOTOR (OPTION)

- Low static pressure (~100 kPa) or high static pressure (~180 kPa) available
- Available on all sizes up to 400 kW



### CARRIER FIXED-SPEED 06T TWIN SCREW COMPRESSOR WITH AC MOTOR

- Exclusive Carrier design
- Twin screw compressor designed for fixed speed operation
- Sliding valve control (30%-100%)
- Bearing life exceeding 100,000 hours
- 99,7% of units without compressor default

## CUSTOMER BENEFITS

### Environmental responsibility

- The AquaForce® with PUREtec™ refrigerant liquid chillers with Greenspeed™ Intelligence is a boost for green cities and contributes to a sustainable future. Combining a reduced charge of R-1234ze refrigerant and exceptional energy efficiency it significantly lowers energy consumption while reducing carbon dioxide emissions by 15% throughout its life cycle (compared to previous fixed-speed screw liquid chiller generation).
- R-1234ze: HFO refrigerant with zero ozone depletion potential and ultra low GWP (<1).
- 40% less refrigerant charge: the micro-channel technology used for condenser coils optimises heat transfer while minimising the refrigerant volume.
- Leak tight refrigerant circuits:
  - Reduction of leaks as no capillary tubes and flare connections are used
  - Verification of pressure transducers and temperature sensors without transferring refrigerant charge
  - Discharge line shut-off valve and liquid line service valve for simplified maintenance.
- Refrigerant leak alert: the AquaForce® 30XBEZE/30XBPZE liquid chiller is equipped with an automatic refrigerant leak detection algorithm that can detect serious refrigerant loss at any point on the system (Sensitivity: 25% refrigerant charge loss per circuit, depending on the conditions). The automatic refrigerant leak detection system can help to achieve recognition within pollution prevention assessment programs, ideal for assisting in the design of sustainable buildings.
- Refrigerant leak detection: available as an option, this additional dry-contact allows reporting of possible leaks. The leak detector (by others) should be mounted in the most likely leak location.



- R-1234ze long-term refrigerant solution
  - HFO refrigerant with nearly zero global warming potential (GWP < 1) and zero ozone depletion potential (ODP = 0).
  - Not impacted by the HFC phase-down plan in Europe (79% HFC reduction in EU member states at 2030 horizon)
  - Compliant with refrigerant regulation in Switzerland that bans the use of HFC refrigerant in large capacity airconditioning equipment.

### Designed to support Green Building Design

A green building is a building that is environmentally sustainable and has been designed, constructed and is operated to minimise the total impact on the environment.

The resulting building will be economical to operate, offer increased comfort and create a healthier environment for the people who live and work there, increasing productivity.

The air conditioning system can use between 30 and 40% of the annual building energy consumption. Selection of the right air conditioning system is one of the main aspects to consider when designing a green building. For buildings with a variable load throughout the year 30XBEZE/30XBPZE units offer a solution to this important challenge.

A number of green building certification programs exist in the market and offer third-party assessment of green building measures for a wide variety of building types.

The following example looks at how Carrier's new 30XBEZE/30XBPZE range helps customers involved in LEED® building certification.

The other benefit of using the AquaForce® with PUREtec™ refrigerant products is the eligibility for BUILDING labeling programs like BREEAM, HQE in France or Green Building Council labelling, that are recognizing the use of sustainable heating and air-conditioning equipment.

Let's take the example of BREEAM assessment method for the sustainability of buildings.

Two credits can be awarded where the refrigerants used in air-conditioning systems have a Global Warming Potential below 10.

And one additional credit can be awarded where the systems have a low Total Equivalent Warming Impact.

The AquaForce® with PUREtec™ refrigerant is not only a solution that is reducing the energy bill and the CO<sub>2</sub> footprint. It also helps the green certification of your buildings.

### Energy saving certificate

AquaForce® with with PUREtec™ refrigerant is eligible to Energy savings certificates in France (CEE) in comfort, industrial and agriculture applications:

- Floating High pressure control (by modulating the air flow through fan activation and its speed)
- Floating Low pressure control
- Variable speed on asynchronous fan motor
- Variable speed on asynchronous pump motor

For more details about financial incentives in France, please refer to "Fiche produit CEE"

## TECHNICAL INSIGHTS

### SmartVu™

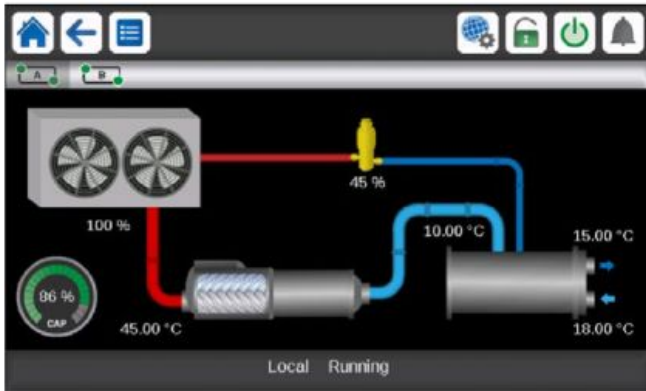

- New innovative smart control features:
  - An intuitive and user-friendly, coloured, 7" interface
  - 10 languages available on choice: DE, EN, ES, FR, IT, NL, PT, TR, TU + one additional customer choice
  - Screen-shots with concise and clear information in local languages
  - Complete menu, customised for different users (end user, service personnel and Carrier-factory technicians)
  - Setpoint offset based on the outside air temperature
  - Safe operation and unit setting: Password protection ensures that unauthorised people cannot modify any advanced parameters
  - Simple and "smart" intelligence uses data collection from the constant monitoring of all machine parameters to optimise unit operation
  - Night-mode: Cooling capacity management for reduced noise level.
  - With hydraulic module: Water pressure display and water flow rate calculation.
- Energy management:
  - Internal time schedule clock controls chiller on/off times and operation at a second set-point
  - The DCT (Data Collection Tool) records the alarms history to simplify and facilitate service operations.
- Maintenance functions
  - F-Gas regulation leak check reminder alert
  - Maintenance alert can be configured to days, months or hours of operation
- Advanced communication features
  - Easy and high-speed communication technology over Ethernet (IP) to a centralised building management system
  - Access to multiple unit parameters.

### Remote management (standard)

- Units with SmartVu™ control can be easily accessed from the internet, using a PC with an Ethernet connection. This makes remote control quick and easy and offers significant advantages for service operations.
- AquaForce® with Greenspeed® Intelligence is equipped with an RS485 serial port that offers multiple remote control, monitoring and diagnostic possibilities. When networked with other Carrier equipment through the CCN (Carrier Comfort Network - proprietary protocol), all components form a HVAC system fully-integrated and balanced through one of the Carrier's network system products, like the Chiller System Manager or the Plant System Manager (optional).

- The 30XBEZE/30XBPZE also communicates with other building management systems via optional communication gateways (BACnet, LON or JBus).
- The following commands/visualisations are possible from remote connection:
  - Start/Stop of the machine
  - Dual set-point management: Through a dedicated contact is possible to activate a second set-point (example, unoccupied mode)
  - Demand limit setting: To limit the maximum chiller capacity to a predefined value
  - Water pump control: These outputs control the contactors of one/two evaporator water pumps.
  - Water pumps changeover (only with hydraulic module options): These contacts are used to detect a water pump operation fault and automatically change over to the other pump.
  - Operation visualisation: Indication if the unit is operating or if it is in stand-by (no cooling load)
  - Alarm visualisation.

### Remote management (EMM option)

- The Energy Management Module (EMM) offers extended remote control possibilities:
  - Room temperature: Permits set-point reset based on the building indoor air temperature (if Carrier thermostats are installed)
  - Set-point reset: Allows reset of the cooling set-point based on a 4-20 mA or 0-10 V signal
  - Demand limit: Permits limitation of the maximum chiller capacity based on 0-10 V signal
  - Demand limit 1 and 2: Closing of these contacts limits the maximum chiller capacity to two predefined values.
  - User safety: This contact can be used for any customer safety loop; opening the contact generates a specific alarm.
  - Ice storage end: When ice storage has finished, this input permits return to the second set-point (unoccupied mode).
  - Time schedule override: Closing of this contact cancels the programmed time schedule.
  - Out of service: This signal indicates that the chiller is completely out of service.
  - Chiller capacity: This analogue output (0-10 V) gives an immediate indication of the chiller capacity.
  - Alert indication: This volt-free contact indicates the necessity to carry out a maintenance operation or the presence of a minor fault.
  - Compressors running status: Set of outputs (as many as the compressors number) indicating which compressors are running.



## TECHNICAL INSIGHTS

### 06T Screw Compressor

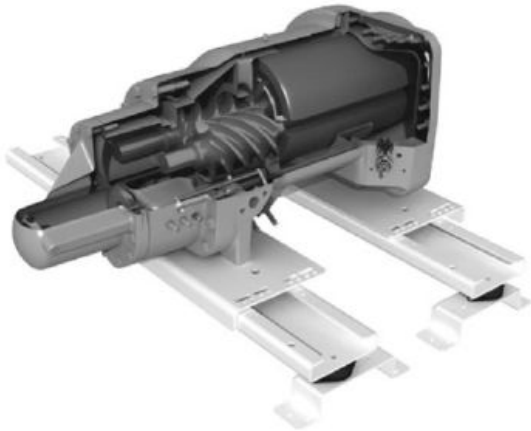

#### 99.7%\* of units without a compressor failure

\* Quality rate measured over a period of 15 years operation

The Carrier 06T screw compressor benefits from Carrier's long experience in the development of twin-rotor screw compressors. The compressor is equipped with bearings with oversized rollers, oil pressure lubricated for reliable and durable operation, even at maximum load.

A variable control valve controlled by the oil pressure permits infinitely variable cooling capacity. This system allows optimal adjustment of the compressor cooling capacity and ensures exceptionally high stability of the chilled water leaving temperature.

Among the other advantages: if a fault occurs e.g. if the condenser is fouled or at very high outside temperature, the compressor does not switch off, but continues operation with a reduced capacity (unloaded mode).

The compressor is equipped with a separate oil separator that minimises the amount of oil in circulation in the refrigerant circuit and, with its integrated silencer, considerably reduces discharge gas pulsations for much quieter operation.

### Novation® Heat Exchangers with Micro-Channel coil Technology

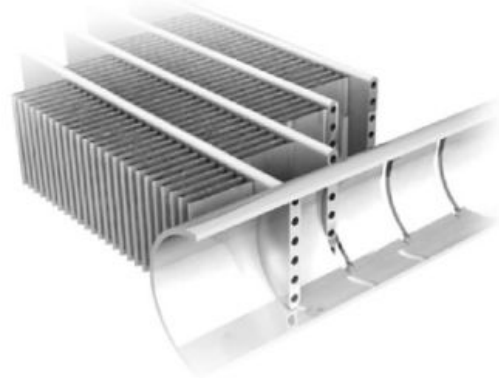

Already utilised in the automobile and aeronautical industries for many years, the Novation™ MCHE micro-channel heat exchanger used in the AquaForce® is entirely made of aluminium. This one-piece concept significantly increases its corrosion resistance by eliminating the galvanic currents that are created when two different metals (copper and aluminium) come into contact in traditional heat exchangers. Unlike traditional heat exchangers the Novation™ MCHE heat exchanger can be used in moderate marine and urban environments (Carrier recommendation).

From an energy efficiency point-of-view the Novation™ MCHE heat exchanger is approximately 10% more efficient than a traditional coil and allows a 40% reduction in the amount of refrigerant used in the chiller. The low thickness of the Novation™ MCHE reduces air pressure losses by 50% and makes it susceptible to very little fouling (e.g. by sand). Cleaning of the Novation™ MCHE heat exchanger is very fast using a high-pressure washer.

Carrier Novation® MCHE with Super Enviro-shield® coating, the ideal customer choice

To further enhance long-term performance, and to protect coils from early deterioration, Carrier offers (as options) dedicated treatments for installations in corrosive environments.

The Novation™ MCHE with Enviro-Shield protection (option 262) are recommended for installations in moderately corrosive environments. The Enviro-Shield protection utilises corrosion inhibitors which actively arrest oxidation in case of mechanical damage.

The Novation™ MCHE with the exclusive Super Enviro-Shield protection (option 263) are recommended for installations in corrosive environments. The Super Enviro-Shield protection consist in an extremely durable and flexible epoxy coating uniformly applied over all coil surfaces for complete isolation from the contaminated environment.

## TECHNICAL INSIGHTS

### Novation® Heat Exchangers with Micro-Channel coil Technology

After a total of more than 7,000 hours of testing following various test standards in UTC laboratories, the Carrier Novation® MCHE with Super Enviro-shield® coating appears to be the ideal customer choice to minimize the harmful effects of corrosive atmospheres and ensure long equipment life.

- Best corrosion resistance per ASTM B117/D610 test
- Best heat transfer performance per Carrier Marine 1 test
- Proven reliability per ASTM B117 test

Coil Types (ranked by performance)	Visual Corrosion Evaluation	Heat Transfer Performance Degradation	Time to Failure	Test Campaign Conclusions
Super Enviro-shield® Novation™ MCHE	Very good	Very good	No coil leak	Best
Super Enviro-shield® Cu/Al coil	Very good	Good	No coil leak	Very good
Enviro-shield® Novation™ MCHE	Very good	Good	No coil leak	Very good
Al/Al coil	Very good	Good	No coil leak	Very good
Novation™ MCHE	Good	Good	No coil leak	Good
Cu/Cu coil	Good	Good	Leak	Acceptable
Blygold® Cu/Al coil	Good	Good	No coil leak	Acceptable
Precoat Cu/Al coil	Bad	Bad	No coil leak	Bad
Cu/Al coil	Bad	Bad	No coil leak	Bad

### New Generation of Flying Bird VI fans



The 30XBEZE and 30XBPZE utilize Carrier's 6<sup>th</sup> generation Flying Bird™ fan technology, engineered for maximum efficiency, super low noise, and wide operating range. The fan includes Carrier patented rotating shroud technology and back-swept blades with a unique wave-serration trailing edge inspired from nature.

It was designed and optimized for the 30XBEZE air management system configuration and heat exchanger technology and is offered with induction and EC motor options. The fan meets the latest European eco-design requirements for fan efficiency. The fan uses Carrier's robust and proven injection molded composite-thermoplastic construction.

## OPTIONS

Options	No.	Description	Advantages	Use for 30XBEZE / 30XBPZE
Medium-temperature brine solution	5	Implementation of new control algorithms and redesigned evaporator to allow chilled brine solution production down to -6°C when ethylene glycol is used (0°C with propylene glycol)	Covers specific applications such as ice storage and industrial processes	30XB(E/P)ZE 200-1200
Low-temperature brine solution	6	Implementation of new control algorithms and redesigned evaporator to allow chilled brine solution production down to -12°C when ethylene glycol is used (-10°C with propylene glycol)	Covers specific applications such as ice storage and industrial processes	30XB(E/P)ZE 200-1200
Unit equipped for air discharge ducting	10	Fans equipped with discharge connection flanges - maximum available pressure 60 Pa	Facilitates connections to the discharge ducts	30XB(E/P)ZE 200-1200
Low noise level	15	Aesthetic and sound absorbing compressor enclosure	Noise level reduction	30XB(E/P)ZE 200-1200
Very low noise level	15LS	Sound absorbing & aesthetic compressor enclosure and oil separator, evaporator and suction line acoustic treatment, combined with low-speed fans	Noise level reduction in sensitive environments	30XB(E/P)ZE 200-1200
Ultra low noise level	15LS+	Acoustic compressor enclosure, low-speed fans and enhanced sound insulation of main noise sources	Noise level reduction for sensible site	30XB(E/P)ZE 200-1200
Tropicalisation	22	Unit control box suitable for tropical climates	Reduced relative humidity in the control boxes for operation in tropical climates (warm and humid)	30XB(E/P)ZE 200-1200
Grilles and enclosure panels	23	Metallic protection grilles and side enclosure panels	Improves aesthetics, protection against intrusion to the unit interior, coil and piping protection against impacts.	30XB(E/P)ZE 200-1200
Enclosure panels	23A	Side enclosure panels	Improves aesthetics and piping protection against impacts.	30XB(E/P)ZE 200-1200
Low inrush current	25C	compressor loading and unloading sequence to limit the unit start-up current	Reduced start-up current	30XB(E/P)ZE 200-1200
Water exchanger frost protection	41A	Electric resistance heater on the water exchanger and discharge valve	Water exchanger frost protection down to -20°C outside temperature	30XB(E/P)ZE 200-1200
Evaporator & hydraulic module frost protection	41B	Electric resistance heater on water exchanger, discharge valve and hydraulic module	Water exchanger and hydraulic module frost protection down to -20°C outside temperature	30XB(E/P)ZE 200-400
Total heat recovery	50	Unit equipped with additional heat exchanger in parallel with the condenser coils.	Production of free hot-water simultaneously with chilled water production	30XB(E/P)ZE 200-750
Total heat recovery on one circuit	50C	Unit equipped with additional heat exchanger in parallel with the condenser coils on one circuit only	Production of free hot-water simultaneously with chilled water production	30XB(E/P)ZE 900-1200
Master/slave operation	58	Unit equipped with supplementary water outlet temperature sensor kit (to be field installed) allowing master/slave operation of two units connected in parallel	Optimised operation of two units connected in parallel operation with operating time equalisation	30XB(E/P)ZE 900-1200
Single power connection point	81	Unit power connection via one main supply connection	Quick and easy installation	30XB(E/P)ZE 900-1200
Evap. and pumps with aluminum jacket	88A	Evaporator and pumps covered with an aluminum sheet for thermal insulation protection	Improved resistance to aggressive climate conditions	30XB(E/P)ZE 200-400
Service valve set	92	Liquid line valve (evaporator inlet) and compressor suction line valve	Allow isolation of various refrigerant circuit components for simplified service and maintenance	30XB(E/P)ZE 200-1200
Compressor discharge valves	93A	Shut-off valve on the compressor discharge piping	Simplified maintenance	30XB(E/P)ZE 200-1200
Evaporator with one pass more	100A	Evaporator with one pass more on the water side	Optimise chiller operation when the chilled water circuit is designed with low waterflows (high evaporator delta T)	30XB(E/P)ZE 200-1200
21 bar evaporator	104	Reinforced evaporator for extension of the maximum water-side service pressure to 21 bar (standard 10 bar)	Covers applications with a high water column evaporator side (typically high buildings)	30XB(E/P)ZE 200-1200
Reversed evaporator water connections	107	Evaporator with reversed water inlet/outlet connections	Easy installation on sites with specific requirements	30XB(E/P)ZE 200-1200
HP dual-pump hydraulic module	116S	Hydraulic module equipped with water filter, two high pressure pumps, drain valve and pressure transducers (expansion tank & aluminum jacket not included).	Easy and fast installation (plug & play).	30XB(E/P)ZE 200-400

OPTIONS

Options	No.	Description	Advantages	Use for 30XBEZE / 30XBPZE
LP dual-pump hydraulic module	116U	Hydraulic module equipped with water filter, two low pressure pumps, drain valve and pressure transducers (expansion tank & aluminum jacket not included).	Easy and fast installation (plug & play).	30XB(E/P)ZE 200-400
Lon gateway	148D	Bi-directional communication board complying with Lon Talk protocol	Connects the unit by communication bus to a building management system	30XB(E/P)ZE 200-1200
Bacnet over IP	149	Bi-directional high-speed communication using BACnet protocol over Ethernet network (IP)	Easy and high-speed connection by ethernet line to a building management system. Allows access to multiple unit parameters	30XB(E/P)ZE 200-1200
Modbus over IP and RS485	149B	Bi-directional high-speed communication using Modbus protocol over Ethernet network (IP)	Easy and high-speed connection by ethernet line to a building management system. Allows access to multiple unit parameters	30XB(E/P)ZE 200-1200
Energy Management Module	156	EMM Control board with additional inputs/ outputs. See Energy Management Module option chapter	Extended remote control capabilities (Set-point reset, ice storage end, demand limits, boiler on/off command...)	30XB(E/P)ZE 200-1200
7" user interface	158A	Control supplied with a 7 inch colour touch screen user interface	Enhanced ease of use.	30XB(E/P)ZE 200-1200
Refrigerant leak detection	159	0-10 V signal to report any refrigerant leakage in the unit directly on the controller (the leak detector itself must be supplied by the customer)	Immediate customer notification of refrigerant losses to the atmosphere, allowing timely corrective actions	30XB(E/P)ZE 200-1200
Dual relief valves on 3-way valve	194	Three-way valve upstream of dual relief valves on the shell and tubes evaporator	Valve replacement and inspection facilitated without refrigerant loss. Comforms to European standard EN378/BGVD4	30XB(E/P)ZE 200-1200
Compliance with Swiss regulations	197	Additional tests on the water heat exchangers: supply (additional of PED documents) supplementary certificates and test certifications	Conformance with Swiss regulations	30XB(E/P)ZE 200-1200
Compliance with Russian regulations	199	EAC certification	Conformance with Russian regulations	30XB(E/P)ZE 200-1200
Compliance with Australian regulations	200	Unit approved to Australian code	Conformance with Australian regulations	30XB(E/P)ZE 200-1200
Insulation of the evap. in/out ref. lines	256	Thermal insulation of the evaporator entering/leaving refrigerant lines with flexible, UV resistant insulation	Prevents condensation on the evaporator entering/leaving refrigerant lines	30XB(E/P)ZE 200-1200
Enviro-Shield anti-corrosion protection	262	Coating by conversion process which modifies the surface of the aluminum producing a coating that is integral to the coil. Complete immersion in a bath to ensure 100% coverage. No heat transfer variation, tested 4000 hours salt spray per ASTM B117	Improved corrosion resistance, recommended for use in moderately corrosive environments	30XB(E/P)ZE 200-1200
Super Enviro-Shield anti-corrosion protection	263	Extremely durable and flexible epoxy polymer coating applied on micro channel heat exchangers by electro coating process, final UV protective topcoat. Minimal heat transfer variation, tested 6000 hours constant neutral salt spray per ASTM B117, superior impact resistance per ASTM D2794	Improved corrosion resistance, recommended for use in extremely corrosive environments	30XB(E/P)ZE 200-1200
Welded evaporator connection kit	266	Victaulic piping connections with welded joints	Easy installation	30XB(E/P)ZE 200-1200
Compressor enclosure	279a	Compressor enclosure	Improved aesthetic, compressor protection against external elements (dust, sand, water...)	30XB(E/P)ZE 200-1200
Evaporator with aluminum jacket	281	Evaporator covered with an aluminum sheet for thermal insulation protection	Improved resistance to aggressive climate conditions	30XB(E/P)ZE 200-1200
230V electrical plug	284	230V AC power supply source provided with plug socket and transformer (180 VA, 0,8 Amps)	Permits connection of a laptop or an electrical device during unit commissioning or servicing	30XB(E/P)ZE 200-1200
Expansion tank	293	6 bar expansion tank integrated in the hydraulic module (requires hydraulic module option)	Easy and fast installation (plug & play), & Protection of closed water systems from excessive pressure	30XB(E/P)ZE 200-1200
US screw compressor	297	Screw compressor made in US		30XB(E/P)ZE 200-1200
Variable Water Flow control	299	hydraulic control function package that permits control of the water flow rate based on different possible logics (at customer choice): constant $\Delta T$ , constant outlet pressure and "fixed-speed" control	When variable-speed pumps on the primary circuit, the VWF control modulates flow rate through the evaporator, minimising pump consumption while ensuring safe/optimised chiller operation	30XB(E/P)ZE 200-1200
Free-cooling dry-cooler control	313	Control & connections to a Free Cooling Dry cooler 09PE or 09VE fitted with option FC control box	Easy system management, Extended control capabilities to a dry cooler used in Free Cooling mode	30XB(E/P)ZE 200-1200



**PHYSICAL DATA, SIZES 30XBEZE 200 TO 600**

30XBEZE		200	230	250	300	350	400	450	500	550	600	
<b>Cooling</b>												
<b>Standard unit</b>	CA1	Nominal capacity	kW									
		Full load performances*	kW/kW									
<b>Unit with option 15LS (+)</b>	CA1	Nominal capacity	kW									
		Full load performances*	kW/kW									
<b>Standard unit</b>	Seasonal energy efficiency **	SEER <sub>12/7°C</sub> Comfort low temp.	kWh/kWh									
		η <sub>s cool</sub> <sub>12/7°C</sub>	%									
		SEPR <sub>12/7°C</sub> Process high temp.	kWh/kWh									
<b>Unit with Option 6</b>	Seasonal energy efficiency **	SEPR <sub>-2/-8°C</sub> Process medium temp.***	kWh/kWh									
		SEER <sub>12/7°C</sub> Comfort low temp.	kWh/kWh									
		η <sub>s cool</sub> <sub>12/7°C</sub>	%									
<b>Unit with Option 299</b>	Seasonal energy efficiency **	SEPR <sub>12/7°C</sub> Process high temp.	kWh/kWh									
		SEER <sub>12/7°C</sub> Comfort low temp.	kWh/kWh									
		η <sub>s cool</sub> <sub>12/7°C</sub>	%									
<b>Unit with Option 5</b>	Seasonal energy efficiency **	SEPR <sub>12/7°C</sub> Process high temp.	kWh/kWh									
		SEER <sub>12/7°C</sub> Comfort low temp.	kWh/kWh									
		η <sub>s cool</sub> <sub>12/7°C</sub>	%									
<b>Unit with option 15LS (+)</b>	Seasonal energy efficiency **	SEPR <sub>12/7°C</sub> Process high temp.	kWh/kWh									
		SEER <sub>12/7°C</sub> Comfort low temp.	kWh/kWh									
		η <sub>s cool</sub> <sub>12/7°C</sub>	%									
<b>Unit with Option 6 &amp; 15LS (+)</b>	Seasonal energy efficiency **	SEPR <sub>-2/-8°C</sub> Process medium temp.***	kWh/kWh									
		SEER <sub>12/7°C</sub> Comfort low temp.	kWh/kWh									
		η <sub>s cool</sub> <sub>12/7°C</sub>	%									
<b>Unit with Option 299 &amp; 15LS (+)</b>	Seasonal energy efficiency **	SEPR <sub>12/7°C</sub> Process high temp.	kWh/kWh									
		SEER <sub>12/7°C</sub> Comfort low temp.	kWh/kWh									
		η <sub>s cool</sub> <sub>12/7°C</sub>	%									
<b>Unit with Option 5 &amp; 15LS (+)</b>	Seasonal energy efficiency **	SEPR <sub>12/7°C</sub> Process high temp.	kWh/kWh									
		SEER <sub>12/7°C</sub> Comfort low temp.	kWh/kWh									
		η <sub>s cool</sub> <sub>12/7°C</sub>	%									
<b>Sound levels</b>												
<b>Standard unit</b>												
Sound power <sup>(1)</sup>	dB(A)		99	99	99	99	101	99	101	99	103	103
Sound pressure at 10 m <sup>(2)</sup>			67	67	67	67	69	67	68	66	70	70
Sound pressure at 1 m	dB(A)		80	80	80	79	81	79	80	78	82	82
<b>Unit + option 15<sup>(3)</sup></b>												
Sound power <sup>(1)</sup>	dB(A)		93	93	94	95	95	95	97	96	97	98
Sound pressure at 10 m <sup>(2)</sup>			61	61	62	63	63	63	64	63	64	65
Sound pressure at 1 m	dB(A)		74	74	75	75	75	75	76	75	76	77
<b>Unit + option 15LS<sup>(3)</sup></b>												
Sound power <sup>(1)</sup>	dB(A)		87	87	87	90	91	91	93	92	94	94
Sound pressure at 10 m <sup>(2)</sup>			55	55	55	58	59	59	60	59	61	61
Sound pressure at 1 m	dB(A)		68	68	68	70	71	71	72	71	73	73
<b>Unit + option 15LS+<sup>(3)</sup></b>												
Sound power <sup>(1)</sup>	dB(A)		-	-	-	-	89	89	91	90	91	92
Sound pressure at 10 m <sup>(2)</sup>			-	-	-	-	57	57	58	57	58	59
Sound pressure at 1 m	dB(A)		-	-	-	-	69	69	70	69	70	71
<b>Dimensions</b>												
<b>Standard unit</b>												
Length	mm		3604	3604	3604	4798	4798	4798	7186	7186	7186	7186
Width	mm		2253	2253	2253	2253	2253	2253	2253	2253	2253	2253
Height	mm		2322	2322	2322	2322	2322	2322	2322	2322	2322	2322

\* In accordance with standard EN14511-3:2022.  
 \*\* In accordance with standard EN14825:2022, average climate  
 \*\*\* With EG 30%  
 CA1 Cooling mode conditions: Evaporator water entering/leaving temperature 12°C/7°C, outside air temperature 35°C, evaporator fouling factor 0 m<sup>2</sup>.K/W  
 η<sub>s cool</sub> <sub>12/7°C</sub> & SEER <sub>12/7°C</sub> **Bold values compliant to Ecodesign regulation: (EU) No 2016/2281 for Comfort application**  
 SEPR <sub>-2/-8°C</sub> **Bold values compliant to Ecodesign regulation: (EU) No 2015/1095 for Process application**  
 NA Non Authorized for the specific application for CEE market  
 - Not applicable  
 (1) in dB ref=10<sup>-12</sup>W, 'A' weighted. Declared dual-number noise emission values in accordance with ISO 4871 with an associated uncertainty of +/-3dB(A). Measured in accordance with ISO 9614-1 and certified by Eurovent.  
 (2) In dB ref 20μPa, 'A' weighted. Declared dual-number noise emission values in accordance with ISO 4871 with an associated uncertainty of +/-3dB(A). For information, calculated from the sound power L<sub>w</sub>(A).  
 (3) Options : 15 = Low noise, 15LS = Very Low noise, 15LS+ = Ultra Low noise



Eurovent certified values



**PHYSICAL DATA, SIZES 30XBEZE 200 TO 600**

30XBEZE		200	230	250	300	350	400	450	500	550	600
<b>Operating weight<sup>(4)</sup></b>											
Standard unit	l	3040	3071	3091	3674	3737	3798	4797	4943	5201	5514
Unit + option 15 <sup>(3)</sup>	l	3308	3339	3359	3973	4036	4097	5128	5274	5532	5845
<b>Compressors</b>											
06T semi-hermetic screw compressor, 50 r/s											
Circuit A		1	1	1	1	1	1	1	1	1	1
Circuit B		1	1	1	1	1	1	1	1	1	1
No. of control stages											
<b>Refrigerant<sup>(4)</sup></b>											
R1234ze(E) / A2L											
Circuit A	kg	37	35	35	51	52	52	58	58	65	69
	teqCO <sub>2</sub>	0,04	0,04	0,04	0,05	0,05	0,05	0,06	0,06	0,07	0,07
Circuit B	kg	39	36	37	37	37	37	59	62	58	65
	teqCO <sub>2</sub>	0,04	0,04	0,04	0,04	0,04	0,04	0,06	0,06	0,06	0,07
<b>Oil</b>											
Circuit A	l	20,8	20,8	20,8	23,5	23,5	23,5	23,5	23,5	27,6	27,6
Circuit B	l	20,8	20,8	20,8	20,8	20,8	20,8	23,5	23,5	23,5	23,5
Capacity control											
SmartVu™, Electronic Expansion Valve (EXV)											
Minimum capacity	%	15	15	15	15	15	15	15	15	15	15
<b>Air heat exchanger</b>											
Aluminum micro-channel coils (MCHE)											
<b>Fans</b>											
Inverter driven Flying Bird (TM) VI fans with AC motors											
<b>Standard unit</b>											
Quantity		6	6	6	8	8	8	11	12	12	12
Maximum total air flow	l/s	28920	28920	28920	38560	38560	38560	53020	57840	57840	57840
Maximum rotation speed	r/s	15,7	15,7	15,7	15,7	15,7	15,7	15,7	15,7	15,7	15,7
<b>Unit + option 15LS</b>											
Maximum total air flow	l/s	23580	23580	23580	31440	31440	31440	43230	47160	47160	47160
Maximum rotation speed	r/s	11,7	11,7	11,7	11,7	11,7	11,7	11,7	11,7	11,7	11,7
<b>Water heat exchanger</b>											
Flooded multi-tube type											
Water volume	l	58	61	61	66	70	77	79	94	98	119
Max. water-side operating pressure without hydraulic module	kPa	1000	1000	1000	1000	1000	1000	1000	1000	1000	1000
<b>Water connections</b>											
Victaulic® type											
<b>Standard</b>											
Nominal diameter	in	5	5	5	5	5	5	5	6	6	6
Actual outside diameter	mm	141,3	141,3	141,3	141,3	141,3	141,3	141,3	168,3	168,3	168,3
<b>Options 100A</b>											
Nominal diameter	in	4	4	4	4	4	4	5	5	5	5
Actual outside diameter	mm	114,3	114,3	114,3	114,3	114,3	114,3	141,3	141,3	141,3	141,3
<b>Options 100C</b>											
Nominal diameter	in	5	5	5	5	5	5	6	6	6	6
Actual outside diameter	mm	141,3	141,3	141,3	141,3	141,3	141,3	168,3	168,3	168,3	168,3
<b>Casing paint</b>											
Colour code RAL 7035											

(3) Options : 15 = Low noise, 15LS = Very Low noise, 15LS+ = Ultra Low noise  
 (4) Values are guidelines only. Refer to the unit name plate.

**PHYSICAL DATA, SIZES 30XBEZE 630 TO 1200**

30XBEZE			630	700	750	900	950	1050	1150	1200	
<b>Cooling</b>											
<b>Standard unit</b>	CA1	Nominal capacity	kW	628	684	755	877	957	1025	1120	1171
Full load performances*		EER	kW/kW	3,29	3,29	3,29	3,30	3,29	3,29	3,26	3,24
<b>Unit with option 15LS (+)</b>	CA1	Nominal capacity	kW	613	671	737	860	935	1003	1093	1146
Full load performances*		EER	kW/kW	3,24	3,24	3,26	3,28	3,22	3,28	3,16	3,25
<b>Standard unit</b>	<b>SEER<sub>12/17°C</sub> Comfort low temp.</b>		<b>kWh/kWh</b>	<b>4,59</b>	<b>4,61</b>	<b>4,59</b>	<b>4,67</b>	<b>4,62</b>	<b>4,61</b>	<b>4,64</b>	<b>4,59</b>
Seasonal energy efficiency **	<b>η<sub>s cool</sub> 12/17°C</b>		<b>%</b>	<b>181</b>	<b>181</b>	<b>180</b>	<b>184</b>	<b>182</b>	<b>181</b>	<b>183</b>	<b>181</b>
	<b>SEPR<sub>12/17°C</sub> Process high temp.</b>		<b>kWh/kWh</b>	<b>5,93</b>	<b>6,10</b>	<b>5,99</b>	<b>5,94</b>	<b>5,64</b>	<b>6,01</b>	<b>5,92</b>	<b>5,95</b>
<b>Unit with Option 6</b>	<b>SEPR<sub>-2/-8°C</sub> Process medium temp.***</b>		<b>kWh/kWh</b>	<b>3,37</b>	<b>3,36</b>	<b>3,38</b>	<b>3,41</b>	<b>3,31</b>	<b>3,48</b>	<b>3,43</b>	<b>3,31</b>
Seasonal energy efficiency **	<b>SEER<sub>12/17°C</sub> Comfort low temp.</b>		<b>kWh/kWh</b>	-	-	-	-	-	-	-	-
	<b>η<sub>s cool</sub> 12/17°C</b>		<b>%</b>	-	-	-	-	-	-	-	-
	<b>SEPR<sub>12/17°C</sub> Process high temp.</b>		<b>kWh/kWh</b>	-	-	-	-	-	-	-	-
<b>Unit with Option 5</b>	<b>SEPR<sub>12/17°C</sub> Process high temp.</b>		<b>kWh/kWh</b>	<b>5,76</b>	<b>5,76</b>	<b>5,75</b>	<b>5,77</b>	<b>5,51</b>	<b>5,89</b>	<b>5,68</b>	<b>5,51</b>
Seasonal energy efficiency **	<b>SEER<sub>12/17°C</sub> Comfort low temp.</b>		<b>kWh/kWh</b>	<b>4,59</b>	<b>4,59</b>	<b>4,56</b>	<b>4,65</b>	<b>4,58</b>	<b>4,60</b>	<b>4,61</b>	<b>4,56</b>
	<b>η<sub>s cool</sub> 12/17°C</b>		<b>%</b>	<b>180</b>	<b>181</b>	<b>179</b>	<b>183</b>	<b>180</b>	<b>181</b>	<b>182</b>	<b>180</b>
	<b>SEPR<sub>12/17°C</sub> Process high temp.</b>		<b>kWh/kWh</b>	<b>5,97</b>	<b>6,15</b>	<b>6,19</b>	<b>6,29</b>	<b>6,04</b>	<b>6,12</b>	<b>6,06</b>	<b>6,00</b>
<b>Unit with Option 6 &amp; 15LS (+)</b>	<b>SEPR<sub>-2/-8°C</sub> Process medium temp.***</b>		<b>kWh/kWh</b>	<b>3,32</b>	<b>3,29</b>	<b>3,36</b>	<b>3,40</b>	<b>3,30</b>	<b>3,47</b>	<b>3,44</b>	<b>3,31</b>
Seasonal energy efficiency **	<b>SEER<sub>12/17°C</sub> Comfort low temp.</b>		<b>kWh/kWh</b>	-	-	-	-	-	-	-	-
	<b>η<sub>s cool</sub> 12/17°C</b>		<b>%</b>	-	-	-	-	-	-	-	-
	<b>SEPR<sub>12/17°C</sub> Process high temp.</b>		<b>kWh/kWh</b>	-	-	-	-	-	-	-	-
<b>Unit with Option 5 &amp; 15LS (+)</b>	<b>SEPR<sub>12/17°C</sub> Process high temp.</b>		<b>kWh/kWh</b>	<b>5,84</b>	<b>5,82</b>	<b>5,82</b>	<b>5,83</b>	<b>5,72</b>	<b>5,91</b>	<b>5,77</b>	<b>5,70</b>
Seasonal energy efficiency **	<b>SEPR<sub>12/17°C</sub> Process high temp.</b>		<b>kWh/kWh</b>	<b>5,84</b>	<b>5,82</b>	<b>5,82</b>	<b>5,83</b>	<b>5,72</b>	<b>5,91</b>	<b>5,77</b>	<b>5,70</b>
<b>Sound levels</b>											
<b>Standard unit</b>											
Sound power <sup>(1)</sup>			dB(A)	101	104	102	103	102	104	104	104
Sound pressure at 10 m <sup>(2)</sup>				68	71	69	70	69	71	71	71
Sound pressure at 1 m <sup>(2)</sup>			dB(A)	80	83	81	81	80	81	81	81
<b>Unit + option 15<sup>(3)</sup></b>											
Sound power <sup>(1)</sup>			dB(A)	97	99	98	98	98	100	99	99
Sound pressure at 10 m <sup>(2)</sup>				64	66	65	65	65	67	66	66
Sound pressure at 1 m <sup>(2)</sup>			dB(A)	76	78	77	76	76	77	76	76
<b>Unit + option 15LS<sup>(3)</sup></b>											
Sound power <sup>(1)</sup>			dB(A)	94	95	94	94	94	99	95	96
Sound pressure at 10 m <sup>(2)</sup>				61	62	61	61	61	66	62	63
Sound pressure at 1 m <sup>(2)</sup>			dB(A)	73	74	73	72	72	76	72	73
<b>Unit + option 15LS+<sup>(3)</sup></b>											
Sound power <sup>(1)</sup>			dB(A)	91	93	92	93	93	97	94	95
Sound pressure at 10 m <sup>(2)</sup>				58	60	59	60	60	64	61	62
Sound pressure at 1 m <sup>(2)</sup>			dB(A)	70	72	71	71	71	74	71	72

\* In accordance with standard EN14511-3:2022.

\*\* In accordance with standard EN14825:2022, average climate

\*\*\* With EG 30%

 CA1 Cooling mode conditions: Evaporator water entering/leaving temperature 12°C/7°C, outside air temperature 35°C, evaporator fouling factor 0 m<sup>2</sup>.K/W

**η<sub>s cool</sub> 12/17°C & SEER<sub>12/17°C</sub> Bold values compliant to Ecodesign regulation: (EU) No 2016/2281 for Comfort application**
**SEPR<sub>-2/-8°C</sub> Bold values compliant to Ecodesign regulation: (EU) No 2015/1095 for Process application**

NA Non Authorized for the specific application for CEE market

- Not applicable

 (1) in dB ref=10<sup>-12</sup> W, 'A' weighted. Declared dual-number noise emission values in accordance with ISO 4871 with an associated uncertainty of +/-3dB(A). Measured in accordance with ISO 9614-1 and certified by Eurovent.

(2) In dB ref 20μPa, 'A' weighted. Declared dual-number noise emission values in accordance with ISO 4871 with an associated uncertainty of +/-3dB(A). For information, calculated from the sound power Lw(A).

(3) Options : 15 = Low noise, 15LS = Very Low noise, 15LS+ = Ultra Low noise



Eurovent certified values

PHYSICAL DATA, SIZES 30XBEZE 630 TO 1200

30XBEZE		630	700	750	900	950	1050	1150	1200
<b>Dimensions</b>									
<b>Standard unit</b>									
Length	mm	7186	8380	8380	10770	10770	11962	11962	13157
Width	mm	2253	2253	2253	2253	2253	2253	2253	2253
Height	mm	2322	2322	2322	2322	2322	2322	2322	2322
<b>Operating weight<sup>(4)</sup></b>									
<b>Standard unit</b>									
kg		5563	6168	6344	7687	7780	8660	8735	9072
<b>Unit + option 15<sup>(3)</sup></b>									
kg		5894	6499	6675	8061	8154	9034	9109	9446
<b>Compressors</b>									
06T semi-hermetic screw compressor, 50 r/s									
Circuit A		1	1	1	1	1	1	1	1
Circuit B		1	1	1	1	1	1	1	1
<b>No. of control stages</b>									
<b>Refrigerant<sup>(4)</sup></b>									
R1234ze(E) / A2L									
<b>Circuit A</b>									
kg		69	72	72	80	80	115	121	124
teqCO <sub>2</sub>		0,07	0,07	0,07	0,08	0,08	0,12	0,12	0,12
<b>Circuit B</b>									
kg		67	74	74	121	126	121	127	130
teqCO <sub>2</sub>		0,07	0,07	0,07	0,12	0,13	0,12	0,13	0,13
<b>Oil</b>									
Oil type									
Circuit A	l	27,6	27,6	27,6	27,6	27,6	36,0	36,0	36,0
Circuit B	l	23,5	27,6	27,6	36,0	36,0	36,0	36,0	36,0
Circuit C	l								
Circuit D	l								
<b>Capacity control</b>									
SmartVu™, Electronic Expansion Valve (EXV)									
<b>Minimum capacity</b>									
%		15	15	15	15	15	15	15	15
<b>Air heat exchanger</b>									
Aluminum micro-channel coils (MCHE)									
<b>Fans</b>									
Inverter driven Flying Bird (TM) VI fans with AC motors									
<b>Standard unit</b>									
Quantity		12	14	14	18	18	20	20	22
Maximum total air flow	l/s	57840	67480	67480	86760	86760	96400	96400	106040
Maximum rotation speed	r/s	15,7	15,7	15,7	15,7	15,7	15,7	15,7	15,7
<b>Unit + option 15LS</b>									
Maximum total air flow	l/s	47160	55020	55020	70740	70740	78600	78600	86460
Maximum rotation speed	r/s	11,7	11,7	11,7	11,7	11,7	11,7	11,7	11,7
<b>Water heat exchanger</b>									
Flooded multi-tube type									
Water volume	l	119	130	140	164	174	180	189	189
Max. water-side operating pressure without hydraulic module	kPa	1000	1000	1000	1000	1000	1000	1000	1000
<b>Water connections</b>									
Victaulic® type									
<b>Standard &amp; option 6</b>									
Nominal diameter	in	6	6	8	6	6	6	6	6
Actual outside diameter	mm	168,3	168,3	219,1	168,3	168,3	168,3	168,3	168,3
<b>Options 5 &amp; 100A</b>									
Nominal diameter	in	5	5	6	6	6	6	6	6
Actual outside diameter	mm	141,3	141,3	168,3	168,3	168,3	168,3	168,3	168,3
<b>Casing paint</b>									
Colour code RAL 7035									

(3) Options : 15 = Low noise, 15LS = Very Low noise, 118a = Dx freecooling option, 50= heat recovery.

(4) Values are guidelines only. Refer to the unit name plate.

## PHYSICAL DATA, SIZES 30XBPZE 200 TO 600

30XBPZE			200	230	250	300	350	400	450	500	550	600	
<b>Cooling</b>													
<b>Standard unit</b> Full load performances*	CA1	Nominal capacity	kW	210	229	246	298	340	380	473	520	556	593
		EER	kW/kW	3,37	3,32	3,34	3,42	3,38	3,37	3,42	3,49	3,33	3,44
<b>Unit with Option 15LS</b> Full load performances*	CA1	Nominal capacity	kW	208	226	244	296	337	374	464	512	546	580
		EER	kW/kW	3,37	3,33	3,29	3,40	3,34	3,30	3,42	3,50	3,29	3,27
<b>Standard unit</b> Seasonal energy efficiency **		<b>SEER</b> <sub>12/7°C</sub> <b>Comfort low temp.</b>	kWh/kWh	<b>4,75</b>	<b>4,68</b>	<b>4,62</b>	<b>4,57</b>	<b>4,61</b>	<b>4,60</b>	<b>4,76</b>	<b>4,86</b>	<b>4,66</b>	<b>4,69</b>
		$\eta_s$ cool <sub>12/7°C</sub>	%	187	184	182	180	182	181	188	192	183	185
		<b>SEPR</b> <sub>12/7°C</sub> <b>Process high temp.</b>	kWh/kWh	6,29	6,42	6,48	6,28	6,31	6,42	6,43	6,44	6,07	6,15
<b>Unit with option 6</b> Seasonal energy efficiency **		<b>SEPR</b> <sub>-2/-8°C</sub> <b>Process medium temp.***</b>	kWh/kWh	3,57	3,58	3,57	3,42	3,58	3,56	3,56	3,65	3,60	3,43
<b>Unit with option 299</b> Seasonal energy efficiency **		<b>SEER</b> <sub>12/7°C</sub> <b>Comfort low temp.</b>	kWh/kWh	4,70	4,70	4,65	4,73	4,76	4,73	-	-	-	-
		$\eta_s$ cool <sub>12/7°C</sub>	%	185	185	183	186	187	186	-	-	-	-
		<b>SEPR</b> <sub>12/7°C</sub> <b>Process high temp.</b>	kWh/kWh	6,28	6,41	6,49	6,32	6,35	6,46	-	-	-	-
		<b>SEPR</b> <sub>12/7°C</sub> <b>Process high temp.</b>	kWh/kWh	6,28	6,43	6,39	6,12	6,30	6,20	6,32	6,35	6,26	5,90
<b>Unit with option 5</b> Seasonal energy efficiency **		<b>SEER</b> <sub>12/7°C</sub> <b>Comfort low temp.</b>	kWh/kWh	4,83	4,70	4,59	4,61	4,60	4,58	4,70	4,86	4,59	4,54
		$\eta_s$ cool <sub>12/7°C</sub>	%	190	185	180	181	181	180	185	191	181	179
		<b>SEPR</b> <sub>12/7°C</sub> <b>Process high temp.</b>	kWh/kWh	6,45	6,54	6,48	6,37	6,33	6,13	6,40	6,43	6,06	6,09
		<b>SEPR</b> <sub>-2/-8°C</sub> <b>Process medium temp.***</b>	kWh/kWh	3,56	3,58	3,57	3,42	3,57	3,54	3,55	3,65	3,60	3,42
<b>Unit with Option 6 &amp; 15LS (+)</b> Seasonal energy efficiency **		<b>SEER</b> <sub>12/7°C</sub> <b>Comfort low temp.</b>	kWh/kWh	4,76	4,71	4,61	4,77	4,74	4,69	-	-	-	-
		$\eta_s$ cool <sub>12/7°C</sub>	%	188	185	181	188	186	185	-	-	-	-
		<b>SEPR</b> <sub>12/7°C</sub> <b>Process high temp.</b>	kWh/kWh	6,44	6,46	NA	6,42	6,37	6,17	-	-	-	-
		<b>SEPR</b> <sub>12/7°C</sub> <b>Process high temp.</b>	kWh/kWh	6,34	6,5	6,43	6,19	6,34	6,30	6,29	6,33	6,21	5,87
<b>Sound levels</b>													
<b>Standard unit</b>													
Sound power <sup>(1)</sup>		dB(A)		99	99	99	99	101	99	101	99	103	103
Sound pressure at 10 m <sup>(2)</sup>		dB(A)		67	67	67	67	69	67	68	66	70	70
Sound pressure at 1 m		dB(A)		80	80	80	79	81	79	80	78	82	82
<b>Unit + option 15<sup>(3)</sup></b>													
Sound power <sup>(1)</sup>		dB(A)		93	93	94	95	95	95	97	96	97	98
Sound pressure at 10 m <sup>(2)</sup>		dB(A)		61	61	62	63	63	63	64	63	64	65
Sound pressure at 1 m		dB(A)		74	74	75	75	75	75	76	75	76	77
<b>Unit + option 15LS<sup>(3)</sup></b>													
Sound power <sup>(1)</sup>		dB(A)		87	87	87	90	91	91	93	92	94	94
Sound pressure at 10 m <sup>(2)</sup>		dB(A)		55	55	55	58	59	59	60	59	61	61
Sound pressure at 1 m		dB(A)		68	68	68	70	71	71	72	71	73	73
<b>Unit + option 15LS+<sup>(3)</sup></b>													
Sound power <sup>(1)</sup>		dB(A)		-	-	-	-	89	89	91	90	91	92
Sound pressure at 10 m <sup>(2)</sup>		dB(A)		-	-	-	-	57	57	58	57	58	59
Sound pressure at 1 m		dB(A)		-	-	-	-	69	69	70	69	70	71

\* In accordance with standard EN14511-3:2022.  
 \*\* In accordance with standard EN14825:2022, average climate  
 \*\*\* With EG 30%  
 CA1 Cooling mode conditions: Evaporator water entering/leaving temperature 12°C/7°C, outside air temperature 35°C, evaporator fouling factor 0 m<sup>2</sup>.K/W  
 $\eta_s$  cool <sub>12/7°C</sub> & SEER <sub>12/7°C</sub> **Bold values compliant to Ecodesign regulation: (EU) No 2016/2281 for Comfort application**  
 SEPR <sub>-2/-8°C</sub> **Bold values compliant to Ecodesign regulation: (EU) No 2015/1095 for Process application**  
 NA Non Authorized for the specific application for CEE market  
 (1) in dB ref=10<sup>-12</sup>W, 'A' weighted. Declared dual-number noise emission values in accordance with ISO 4871 with an associated uncertainty of +/-3dB(A). Measured in accordance with ISO 9614-1 and certified by Eurovent.  
 (2) In dB ref 20µPa, 'A' weighted. Declared dual-number noise emission values in accordance with ISO 4871 with an associated uncertainty of +/-3dB(A). For information, calculated from the sound power Lw(A).  
 (3) Options : 15 = Low noise, 15LS = Very Low noise, 118a = Dx freecooling option, 50= heat recovery.



Eurovent certified values

PHYSICAL DATA, SIZES 30XBPZE 200 TO 600

30XBPZE		200	230	250	300	350	400	450	500	550	600
<b>Dimensions</b>											
Standard unit											
Length	mm	3604	3604	3604	4798	4798	4798	7186	7186	7186	7186
Width	mm	2253	2253	2253	2253	2253	2253	2253	2253	2253	2253
Height	mm	2322	2322	2322	2322	2322	2322	2322	2322	2322	2322
<b>Operating weight<sup>(4)</sup></b>											
Standard unit											
	kg	3015	3047	3066	3652	3715	3776	4761	4895	5161	5474
Unit + option 15 <sup>(3)</sup>											
	kg	3283	3314	3334	3952	4014	4075	5092	5226	5492	5805
<b>Compressors</b>											
06T semi-hermetic screw compressor, 50 r/s											
Circuit A	l	1	1	1	1	1	1	1	1	1	1
Circuit B		1	1	1	1	1	1	1	1	1	1
No. of control stages	l										
<b>Refrigerant<sup>(4)</sup></b>											
R1234ze(E) / A2L											
Circuit A	kg	39	37	37	52	53	55	60	61	69	69
	teqCO <sub>2</sub>	0,04	0,04	0,04	0,05	0,05	0,05	0,06	0,06	0,07	0,07
Circuit B	kg	40,0	38	39	40	40	36	61	64	61	67
	teqCO <sub>2</sub>	0,04	0,04	0,04	0,04	0,04	0,04	0,06	0,06	0,06	0,07
<b>Oil</b>											
Circuit A	l	20,8	20,8	20,8	23,5	23,5	23,5	23,5	23,5	27,6	27,6
Circuit B	l	20,8	20,8	20,8	20,8	20,8	20,8	23,5	23,5	23,5	23,5
<b>Capacity control</b>											
SmartVu™, Electronic Expansion Valve (EXV)											
Minimum capacity	%	15	15	15	15	15	15	15	15	15	15
<b>Air heat exchanger</b>											
Aluminum micro-channel coils (MCHE)											
<b>Fans</b>											
Inverter driven Flying Bird (TM) VI fans with EC motors											
<b>Standard unit</b>											
Quantity		6	6	6	8	8	8	11	12	12	12
Maximum total air flow	l/s	28920	28920	28920	38560	38560	38560	53020	57840	57840	57840
Maximum rotation speed	r/s	15,7	15,7	15,7	15,7	15,7	15,7	15,7	15,7	15,7	15,7
<b>Unit + option 15LS</b>											
Maximum total air flow	l/s	23580	23580	23580	31440	31440	31440	43230	47160	47160	47160
Maximum rotation speed	r/s	11,7	11,7	11,7	11,7	11,7	11,7	11,7	11,7	11,7	11,7
<b>Water heat exchanger</b>											
Flooded multi-tube type											
Water volume	l	58	61	61	66	70	77	79	94	98	119
Max. water-side operating pressure without hydraulic module	kPa	1000	1000	1000	1000	1000	1000	1000	1000	1000	1000
<b>Water connections</b>											
Victaulic® type											
<b>Standard &amp; option 6</b>											
Nominal diameter	in	5	5	5	5	5	5	5	6	6	6
Actual outside diameter	mm	141,3	141,3	141,3	141,3	141,3	141,3	141,3	168,3	168,3	168,3
<b>Options 5 &amp; 100A</b>											
Nominal diameter	in	4	4	4	4	4	4	5	5	5	5
Actual outside diameter	mm	114,3	114,3	114,3	114,3	114,3	114,3	141,3	141,3	141,3	141,3
<b>Casing paint</b>											
Colour code RAL 7035											

(3) Options : 15 = Low noise, 15LS = Very Low noise, 118a = Dx freecooling option, 50= heat recovery.

(4) Values are guidelines only. Refer to the unit name plate.



## PHYSICAL DATA, SIZES 30XBPZE 0630 TO 1200

30XBPZE			630	700	750	900	950	1050	1150	1200	
<b>Cooling</b>											
<b>Standard unit</b>	CA1	Nominal capacity	kW	637	685	763	880	968	1026	1120	1173
Full load performances*		EER	kW/kW	3,44	3,35	3,43	3,39	3,42	3,35	3,31	3,34
<b>Unit with Option 15LS (+)</b>	CA1	Nominal capacity	kW	623	671	748	864	949	1002	1093	1145
Full load performances*		EER	kW/kW	3,43	3,27	3,44	3,40	3,42	3,31	3,18	3,26
<b>Standard unit</b>		<b>SEER<sub>12/7°C</sub> Comfort low temp.</b>	kWh/kWh	<b>4,75</b>	<b>4,70</b>	<b>4,79</b>	<b>4,79</b>	<b>4,79</b>	<b>4,69</b>	<b>4,66</b>	<b>4,65</b>
		<b>ηs cool<sub>12/7°C</sub></b>	%	<b>187</b>	<b>185</b>	<b>189</b>	<b>189</b>	<b>189</b>	<b>185</b>	<b>183</b>	<b>183</b>
Seasonal energy efficiency **		<b>SEPR<sub>12/7°C</sub> Process high temp.</b>	kWh/kWh	<b>6,03</b>	<b>6,15</b>	<b>6,07</b>	<b>6,00</b>	<b>5,73</b>	<b>6,07</b>	<b>5,99</b>	<b>6,07</b>
		<b>SEPR<sub>-2/-8°C</sub> Process medium temp.***</b>	kWh/kWh	<b>3,43</b>	<b>3,41</b>	<b>3,45</b>	<b>3,47</b>	<b>3,37</b>	<b>3,53</b>	<b>3,49</b>	<b>3,36</b>
Unit with option 6 Seasonal energy efficiency **		<b>SEER<sub>12/7°C</sub> Comfort low temp.</b>	kWh/kWh	-	-	-	-	-	-	-	-
		<b>ηs cool<sub>12/7°C</sub></b>	%	-	-	-	-	-	-	-	-
Unit with option 299 Seasonal energy efficiency **		<b>SEPR<sub>12/7°C</sub> Process high temp.</b>	kWh/kWh	-	-	-	-	-	-	-	-
		<b>SEPR<sub>12/7°C</sub> Process high temp.</b>	kWh/kWh	-	-	-	-	-	-	-	-
Unit with Option 5 Seasonal energy efficiency **		<b>SEPR<sub>12/7°C</sub> Process high temp.</b>	kWh/kWh	<b>5,84</b>	<b>5,84</b>	<b>5,82</b>	<b>5,86</b>	<b>5,61</b>	<b>5,99</b>	<b>5,76</b>	<b>5,65</b>
		<b>SEER<sub>12/7°C</sub> Comfort low temp.</b>	kWh/kWh	<b>4,70</b>	<b>4,57</b>	<b>4,69</b>	<b>4,70</b>	<b>4,71</b>	<b>4,67</b>	<b>4,60</b>	<b>4,61</b>
Unit with option 15LS(+) Seasonal energy efficiency **		<b>ηs cool<sub>12/7°C</sub></b>	%	<b>185</b>	<b>180</b>	<b>185</b>	<b>185</b>	<b>185</b>	<b>184</b>	<b>181</b>	<b>181</b>
		<b>SEPR<sub>12/7°C</sub> Process high temp.</b>	kWh/kWh	<b>6,00</b>	<b>6,13</b>	<b>6,00</b>	<b>5,96</b>	<b>5,72</b>	<b>6,05</b>	<b>5,93</b>	<b>5,95</b>
		<b>SEPR<sub>-2/-8°C</sub> Process medium temp.***</b>	kWh/kWh	<b>3,41</b>	<b>3,37</b>	<b>3,44</b>	<b>3,46</b>	<b>3,36</b>	<b>3,51</b>	<b>3,46</b>	<b>3,34</b>
Unit with Option 6 & 15LS (+) Seasonal energy efficiency **		<b>SEER<sub>12/7°C</sub> Comfort low temp.</b>	kWh/kWh	-	-	-	-	-	-	-	-
		<b>ηs cool<sub>12/7°C</sub></b>	%	-	-	-	-	-	-	-	-
		<b>SEPR<sub>12/7°C</sub> Process high temp.</b>	kWh/kWh	-	-	-	-	-	-	-	-
Unit with Option 299 & 15LS (+) Seasonal energy efficiency **		<b>SEPR<sub>12/7°C</sub> Process high temp.</b>	kWh/kWh	<b>5,84</b>	<b>5,83</b>	<b>5,76</b>	<b>5,83</b>	<b>5,55</b>	<b>5,96</b>	<b>5,73</b>	<b>5,58</b>
		<b>SEPR<sub>12/7°C</sub> Process high temp.</b>	kWh/kWh	<b>5,84</b>	<b>5,83</b>	<b>5,76</b>	<b>5,83</b>	<b>5,55</b>	<b>5,96</b>	<b>5,73</b>	<b>5,58</b>
<b>Sound levels</b>											
<b>Standard unit</b>											
Sound power <sup>(1)</sup>			dB(A)	101	104	102	103	102	104	104	104
Sound pressure at 10 m <sup>(2)</sup>				68	71	69	70	69	71	71	71
Sound pressure at 1 m			dB(A)	80	83	80	80	79	81	81	81
<b>Unit + option 15<sup>(3)</sup></b>											
Sound power <sup>(1)</sup>			dB(A)	97	99	98	98	98	100	99	99
Sound pressure at 10 m <sup>(2)</sup>				64	66	65	65	65	67	66	66
Sound pressure at 1 m			dB(A)	76	78	76	75	75	77	76	76
<b>Unit + option 15LS<sup>(3)</sup></b>											
Sound power <sup>(1)</sup>			dB(A)	94	95	94	94	94	99	95	96
Sound pressure at 10 m <sup>(2)</sup>				61	62	61	61	61	66	62	63
Sound pressure at 1 m			dB(A)	73	74	72	71	71	76	72	73
<b>Unit + option 15LS+<sup>(3)</sup></b>											
Sound power <sup>(1)</sup>			dB(A)	91	92	92	93	93	97	94	95
Sound pressure at 10 m <sup>(2)</sup>				58	59	59	60	60	64	61	62
Sound pressure at 1 m			dB(A)	70	71	70	70	70	74	71	72

\* In accordance with standard EN14511-3:2022.  
 \*\* In accordance with standard EN14825:2022, average climate  
 \*\*\* With EG 30%  
 CA1 Cooling mode conditions: Evaporator water entering/leaving temperature 12°C/7°C, outside air temperature 35°C, evaporator fouling factor 0 m<sup>2</sup>.K/W  
**ηs cool<sub>12/7°C</sub> & SEER<sub>12/7°C</sub>** **Bold values compliant to Ecodesign regulation: (EU) No 2016/2281 for Comfort application**  
**SEPR<sub>-2/-8°C</sub>** **Bold values compliant to Ecodesign regulation: (EU) No 2015/1095 for Process application**  
 NA Non Authorized for the specific application for CEE market  
 (1) In dB ref=10<sup>-12</sup>W, 'A' weighted. Declared dual-number noise emission values in accordance with ISO 4871 with an associated uncertainty of +/-3dB(A). Measured in accordance with ISO 9614-1 and certified by Eurovent.  
 (2) In dB ref 20μPa, 'A' weighted. Declared dual-number noise emission values in accordance with ISO 4871 with an associated uncertainty of +/-3dB(A). For information, calculated from the sound power Lw(A).  
 (3) Options : 15 = Low noise, 15LS = Very Low noise, 15LS+ = Ultra Low noise



Eurovent certified values

**PHYSICAL DATA, SIZES 30XBPZE 0630 TO 1200**

30XBPZE		630	700	750	900	950	1050	1150	1200
<b>Dimensions</b>									
Standard unit									
Length	mm	8380	8380	9574	11962	11962	11962	11962	13157
Width	mm	2253	2253	2253	2253	2253	2253	2253	2253
Height	mm	2322	2322	2322	2322	2322	2322	2322	2322
<b>Operating weight<sup>(4)</sup></b>									
Standard unit									
	kg	5841	6114	6607	7867	7993	8622	8697	9000
Unit + option 15 <sup>(3)</sup>									
	kg	6172	6445	6938	8241	8367	8996	9071	9374
<b>Compressors</b>									
06T semi-hermetic screw compressor, 50 r/s									
Circuit A	l	1	1	1	1	1	1	1	1
Circuit B		1	1	1	1	1	1	1	1
No. of control stages	l								
<b>Refrigerant<sup>(4)</sup></b>									
R1234ze(E) / A2L									
Circuit A									
	kg	75	72	79	82	84	115	121	124
	teqCO <sub>2</sub>	0,08	0,07	0,08	0,08	0,08	0,12	0,12	0,12
Circuit B									
	kg	67	74	83	118	130	121	127	130
	teqCO <sub>2</sub>	0,07	0,07	0,08	0,12	0,13	0,12	0,13	0,13
<b>Oil</b>									
Circuit A									
	l	27,6	27,6	27,6	27,6	27,6	36,0	36,0	36,0
Circuit B									
	l	23,5	27,6	27,6	36,0	36,0	36,0	36,0	36,0
<b>Capacity control</b>									
SmartVu™, Electronic Expansion Valve (EXV)									
Minimum capacity	%	15	15	15	15	15	15	15	15
<b>Air heat exchanger</b>									
Aluminum micro-channel coils (MCHE)									
<b>Fans</b>									
Inverter driven Flying Bird (TM) VI fans with EC motors									
<b>Standard unit</b>									
Quantity		14	14	16	19	20	20	20	22
Maximum total air flow	l/s	67480	67480	77120	91580	96400	96400	96400	106040
Maximum rotation speed	r/s	15,7	15,7	15,7	15,7	15,7	15,7	15,7	15,7
<b>Unit + option 15LS</b>									
Maximum total air flow	l/s	55020	55020	62880	74670	78600	78600	78600	86460
Maximum rotation speed	r/s	11,7	11,7	11,7	11,7	11,7	11,7	11,7	11,7
<b>Water heat exchanger</b>									
Flooded multi-pipe type									
Water volume	l	119	130	140	164	174	180	189	189
Max. water-side operating pressure without hydraulic module	kPa	1000	1000	1000	1000	1000	1000	1000	1000
<b>Water connections</b>									
Victaulic® type									
<b>Standard &amp; option 6</b>									
Nominal diameter	in	6	6	8	6	6	6	6	6
Actual outside diameter	mm	168.3	168.3	219.1	168.3	168.3	168.3	168.3	168.3
<b>Options 5 &amp; 100A</b>									
Nominal diameter	in	5	5	6	6	6	6	6	6
Actual outside diameter	mm	141.3	141.3	168.3	168.3	168.3	168.3	168.3	168.3
<b>Casing paint</b>									
Colour code RAL 7035									

(3) Options : 15 = Low noise, 15LS = Very Low noise, 15LS+ = Ultra Low noise  
 (4) Values are guidelines only. Refer to the unit name plate.

## ELECTRICAL DATA, 30XBEZE 200 TO 750

30XBEZE		200	230	250	300	350	400	450	500	550	600	630	700	750
<b>Power circuit supply</b>														
Nominal voltage	V-ph-Hz	400-3-50												
Voltage range	V	360-440												
<b>Control circuit supply</b>														
24 V via internal transformer														
<b>Maximum operating input power <sup>(1)</sup></b>														
Standard unit	kW	97	105	112	142	160	174	224	239	257	270	281	305	327
Unit + option 15LS	kW	92	99	107	135	153	167	214	229	246	260	271	293	315
<b>Power factor at maximum power <sup>(1)</sup></b>														
Standard unit														
Displacement Power Factor (Cos Phi)		0,90	0,90	0,89	0,90	0,90	0,90	0,90	0,90	0,89	0,89	0,90	0,88	0,89
<b>Unit + option 15LS</b>														
Displacement Power Factor (Cos Phi)		0,90	0,90	0,89	0,89	0,90	0,88	0,89	0,90	0,89	0,89	0,89	0,89	0,89
<b>Nominal operating current draw <sup>(2)</sup></b>														
Standard unit	A	116	125	134	161	181	198	248	268	288	304	314	347	367
Unit + option 15LS	A	107	116	125	149	169	185	231	249	269	286	296	326	345
<b>Maximum operating current draw (Un) <sup>(1)</sup></b>														
Standard unit	A	155	169	182	227	258	280	359	384	417	439	454	500	530
Unit + option 15LS	A	147	160	173	216	247	269	343	367	400	422	437	480	510
<b>Maximum current (Un-10%) <sup>(1)</sup></b>														
Standard unit	A	166	181	195	244	277	300	385	412	447	471	488	537	569
Unit + option 15LS	A	158	172	187	232	265	289	369	395	430	454	471	517	549
<b>Nominal start-up current <sup>(3)</sup></b>														
Standard unit	A	227	227	236	360	454	454	501	521	700	717	717	759	769
Unit + option 15LS	A	223	223	232	356	450	450	494	512	693	710	710	749	759
Unit + option 25C	A	184	180	189	317	407	407	392	412	605	612	612	628	642
<b>Maximum start-up current(Un) <sup>(2)</sup></b>														
Standard unit	A	248	261	261	381	479	479	581	580	754	776	776	837	852
Unit + option 15LS	A	244	257	257	377	475	475	574	572	747	769	769	827	842
Unit + option 25C	A	205	214	214	338	432	432	472	472	659	671	671	706	725

(1) Values obtained at unit continuous maximum operating conditions (data given on the unit nameplate)

(2) Operating current of the smallest compressor(s) + fan current + locked rotor current or reduced start-up current of the largest compressor.

(3) Standardised EUROVENT conditions, water-cooled exchanger water inlet/outlet = 12°C/7°C, outdoor air temperature = 35°C.

**ELECTRICAL DATA, 30XBEZE 0900 TO 1200**

30XBEZE		900	950	1050	1150	1200
<b>Power circuit supply</b>						
Nominal voltage	V-ph-Hz	400-3-50				
Voltage range	V	360-440				
<b>Control circuit supply</b>		24 V via internal transformer				
<b>Maximum operating input power<sup>(1)</sup> - 30XBEZE</b>						
<b>Standard unit</b>						
Circuit 1 <sup>(a)</sup>	kW	154	163	224	245	262
Circuit 2 <sup>(a)</sup>	kW	246	262	244	260	262
Option 081	kW	399	426	468	505	524
<b>Unit + option 15LS</b>						
Circuit 1 <sup>(a)</sup>	kW	147	157	215	236	253
Circuit 2 <sup>(a)</sup>	kW	236	253	235	252	253
Option 081	kW	383	410	450	487	505
<b>Power factor at maximum power<sup>(1)</sup> - 30XBEZE</b>						
<b>Standard unit</b>						
Displacement Power Factor (Cos Phi)		0,89	0,89	0,89	0,89	0,89
<b>Unit + option 15LS</b>						
Displacement Power Factor (Cos Phi)		0,89	0,89	0,89	0,89	0,89
<b>Nominal operating current draw<sup>(2)</sup> - 30XBEZE</b>						
<b>Standard unit</b>						
Circuit 1 <sup>(a)</sup>	A	174	184	250	267	292
Circuit 2 <sup>(a)</sup>	A	270	292	267	288	292
Option 081	A	444	475	516	555	583
<b>Unit + option 15LS</b>						
Circuit 1 <sup>(a)</sup>	A	163	173	235	252	275
Circuit 2 <sup>(a)</sup>	A	253	275	252	273	275
Option 081	A	416	447	486	524	549
<b>Maximum operating current draw (Un)<sup>(1)</sup> - 30XBEZE</b>						
<b>Standard unit</b>						
Circuit 1 <sup>(a)</sup>	A	250	265	365	397	425
Circuit 2 <sup>(a)</sup>	A	400	425	397	422	425
Option 081	A	650	690	762	819	850
<b>Unit + option 15LS</b>						
Circuit 1 <sup>(a)</sup>	A	240	255	351	383	410
Circuit 2 <sup>(a)</sup>	A	384	410	383	408	410
Option 081	A	624	665	733	790	819
<b>Maximum current (Un-10%)<sup>(1)</sup> - 30XBEZE</b>						
<b>Standard unit</b>						
Circuit 1 <sup>(a)</sup>	A	269	285	392	426	457
Circuit 2 <sup>(a)</sup>	A	429	457	426	454	457
Option 081	A	697	741	818	879	913
<b>Unit + option 15LS</b>						
Circuit 1 <sup>(a)</sup>	A	259	275	378	412	441
Circuit 2 <sup>(a)</sup>	A	414	441	412	440	441
Option 081	A	672	716	790	851	882
<b>Nominal start-up current<sup>(3)</sup> - 30XBEZE</b>						
Circuit 1 <sup>(a)</sup>	A	587	587	629	629	629
Circuit 2 <sup>(a)</sup>	A	629	629	629	629	629
Option 081	A	854	876	893	915	918
Option 081 & Opt 25c	A	629	640	672	683	683
<b>Maximum start-up current(Un)<sup>(2)</sup> - 30XBEZE</b>						
Circuit 1 <sup>(a)</sup>	A	587	587	629	629	629
Circuit 2 <sup>(a)</sup>	A	629	629	629	629	629
Option 081	A	987	1012	1026	1051	1054
Option 081 & Opt 25c	A	761	776	804	819	818

(1) Values obtained at unit continuous maximum operating conditions (data given on the unit nameplate)

(2) Operating current of the smallest compressor(s) + fan current + locked rotor current or reduced start-up current of the largest compressor.

(3) Standardised EUROVENT conditions, water-cooled exchanger water inlet/outlet = 12°C/7°C, outdoor air temperature = 35°C.

(a) When the machines are equipped with two power supplies, circuit 1 supplies the refrigerant circuit A and circuit 2 supplies the refrigerant circuit B.

## ELECTRICAL DATA, 30XBPZE 200 TO 750

30XBPZE		200	230	250	300	350	400	450	500	550	600	630	700	750
<b>Power circuit supply</b>														
Nominal voltage	V-ph-Hz	400-3-50												
Voltage range	V	360-440												
<b>Control circuit supply</b>														
24 V via internal transformer														
<b>Maximum operating input power <sup>(1)</sup></b>														
Standard unit	kW	96	103	111	140	158	172	222	237	255	268	282	302	328
Unit + option 15LS	kW	94	101	109	138	156	170	218	233	250	264	278	298	323
<b>Power factor at maximum power <sup>(1)</sup></b>														
Standard unit														
Displacement Power Factor (Cos Phi)		0,90	0,89	0,89	0,90	0,89	0,89	0,90	0,90	0,89	0,89	0,89	0,88	0,89
<b>Unit + option 15LS</b>														
Displacement Power Factor (Cos Phi)		0,90	0,89	0,89	0,90	0,89	0,89	0,90	0,90	0,89	0,89	0,89	0,88	0,89
<b>Nominal operating current draw <sup>(2)</sup></b>														
Standard unit	A	113	122	131	158	177	194	243	262	282	299	314	341	366
Unit + option 15LS	A	110	119	128	154	173	190	237	256	276	293	307	334	358
<b>Maximum operating current draw (Un) <sup>(1)</sup></b>														
Standard unit	A	154	167	181	226	256	278	357	382	415	437	457	497	533
Unit + option 15LS	A	151	164	178	222	252	274	351	375	408	430	450	490	525
<b>Maximum current (Un-10%) <sup>(1)</sup></b>														
Standard unit	A	165	180	194	242	275	299	383	409	445	469	491	534	572
Unit + option 15LS	A	162	176	191	238	271	295	377	403	439	463	483	527	564
<b>Nominal start-up current <sup>(3)</sup></b>														
Standard unit	A	227	227	236	360	454	454	500	519	699	716	718	758	770
Unit + option 15LS	A	225	225	234	358	452	452	498	516	697	713	715	754	766
Unit + option 25C	A	184	180	189	317	407	407	392	411	604	611	614	626	643
<b>Maximum start-up current(Un) <sup>(2)</sup></b>														
Standard unit	A	247	261	261	380	479	479	580	579	753	775	778	836	854
Unit + option 15LS	A	246	259	259	379	477	477	577	576	751	773	775	832	850
Unit + option 25C	A	204	213	213	337	431	431	471	470	658	670	673	705	727

(1) Values obtained at unit continuous maximum operating conditions (data given on the unit nameplate)

(2) Operating current of the smallest compressor(s) + fan current + locked rotor current or reduced start-up current of the largest compressor.

(3) Standardised EUROVENT conditions, water-cooled exchanger water inlet/outlet = 12°C/7°C, outdoor air temperature = 35°C.



**ELECTRICAL DATA, 30XBPZE 900 TO 1200**

30XBPZE		200	600	630	700	750
<b>Power circuit supply</b>						
Nominal voltage	V-ph-Hz	400-3-50				
Voltage range	V	360-440				
<b>Control circuit supply</b>						
24 V via internal transformer						
<b>Maximum operating input power <sup>(1)</sup></b>						
<b>Standard unit</b>						
Circuit 1 <sup>(a)</sup>	kW	154	164	222	243	260
Circuit 2 <sup>(a)</sup>	kW	244	262	242	258	260
Option 081	kW	397	425	464	501	520
<b>Unit + option 15LS</b>						
Circuit 1 <sup>(a)</sup>	kW	151	162	219	240	256
Circuit 2 <sup>(a)</sup>	kW	240	258	239	255	256
Option 081	kW	391	419	457	494	513
<b>Power factor at maximum power <sup>(1)</sup></b>						
<b>Standard unit</b>						
Displacement Power Factor (Cos Phi)		0,88	0,89	0,88	0,89	0,89
<b>Unit + option 15LS</b>						
Displacement Power Factor (Cos Phi)		0,88	0,89	0,88	0,89	0,89
<b>Nominal operating current draw <sup>(2)</sup> - 30XBEZE</b>						
<b>Standard unit</b>						
Circuit 1 <sup>(a)</sup>	A	173	183	245	263	287
Circuit 2 <sup>(a)</sup>	A	265	289	263	284	287
Option 081	A	438	472	507	546	573
<b>Unit + option 15LS</b>						
Circuit 1 <sup>(a)</sup>	A	169	179	240	257	281
Circuit 2 <sup>(a)</sup>	A	260	283	257	279	281
Option 081	A	428	462	497	536	561
<b>Maximum operating current draw (Un) <sup>(1)</sup></b>						
<b>Standard unit</b>						
Circuit 1 <sup>(a)</sup>	A	252	267	363	395	423
Circuit 2 <sup>(a)</sup>	A	398	426	395	420	423
Option 081	A	649	692	758	815	846
<b>Unit + option 15LS</b>						
Circuit 1 <sup>(a)</sup>	A	247	263	358	390	417
Circuit 2 <sup>(a)</sup>	A	392	420	390	415	417
Option 081	A	639	682	747	804	834
<b>Maximum current (Un-10%) <sup>(1)</sup></b>						
<b>Standard unit</b>						
Circuit 1 <sup>(a)</sup>	A	270	286	390	424	454
Circuit 2 <sup>(a)</sup>	A	427	457	424	452	454
Option 081	A	697	743	814	876	908
<b>Unit + option 15LS</b>						
Circuit 1 <sup>(a)</sup>	A	266	282	385	419	449
Circuit 2 <sup>(a)</sup>	A	421	451	419	447	449
Option 081	A	687	733	804	865	897
<b>Nominal start-up current <sup>(3)</sup></b>						
Circuit 1 <sup>(a)</sup>	A	587	587	629	629	629
Circuit 2 <sup>(a)</sup>	A	629	629	629	629	629
Option 081	A	852	876	892	913	916
Option 081 & Opt 25c	A	627	640	670	681	680
<b>Maximum start-up current(Un) <sup>(2)</sup></b>						
Circuit 1 <sup>(a)</sup>	A	587	587	629	629	629
Circuit 2 <sup>(a)</sup>	A	629	629	629	629	629
Option 081	A	985	1013	1024	1049	1052
Option 081 & Opt 25c	A	759	777	802	817	816

(1) Values obtained at unit continuous maximum operating conditions (data given on the unit nameplate)

(2) Operating current of the smallest compressor(s) + fan current + locked rotor current or reduced start-up current of the largest compressor.

(3) Standardised EUROVENT conditions, water-cooled exchanger water inlet/outlet = 12°C/7°C, outdoor air temperature = 35°C.

(a) When the machines are equipped with two power supplies, circuit 1 supplies the refrigerant circuit A and circuit 2 supplies the refrigerant circuit B.

## DIMENSIONS / CLEARANCES

### 30XB(P)ZE 0200 to 250

POWER AND CONTROL ELECTRICAL BOX

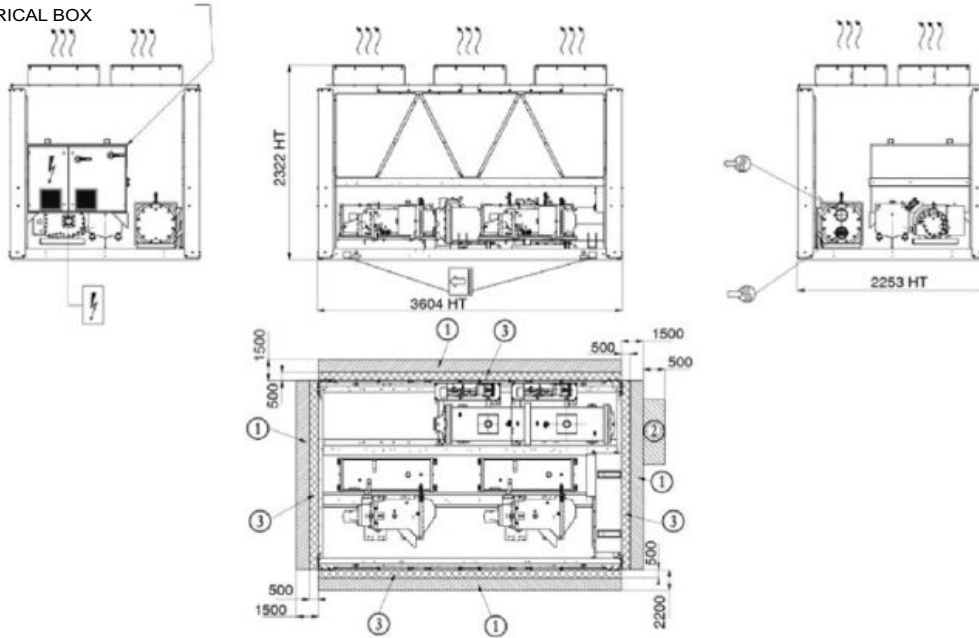

### 30XB(P)ZE 0300 to 400

POWER AND CONTROL ELECTRICAL BOX

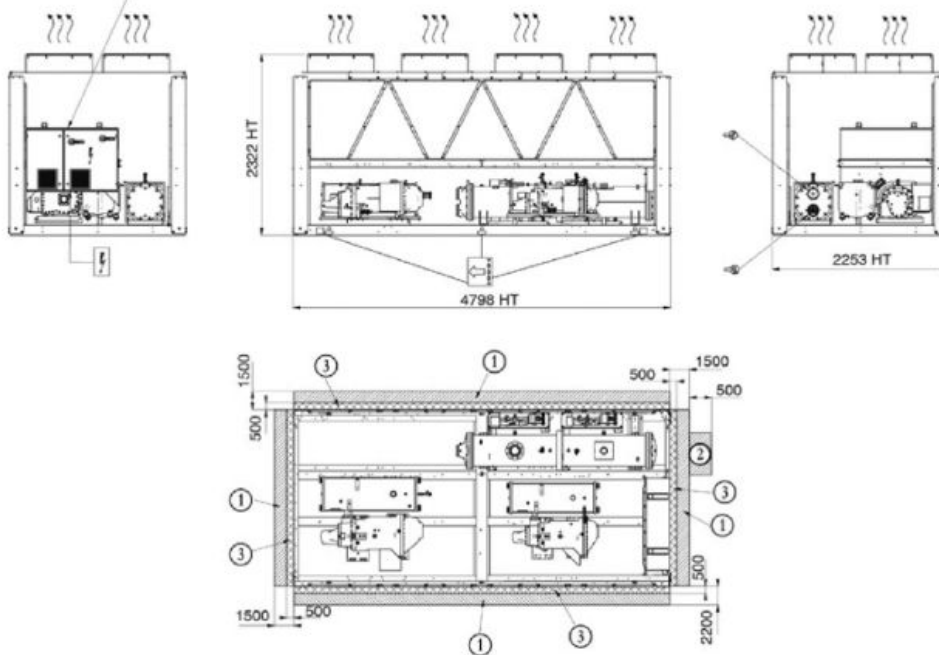

**Legend**

All dimensions are given in mm.

- ① Required clearances for maintenance (see note)
- ② Recommended space for evaporator tube removal
- ③ ATEX zone around the unit
- Water inlet for standard unit - for options 100A, 100C, 107 refer to the certified drawing.
- Water outlet for standard unit - for options 100A, 100C, 107 refer to the certified drawing.
- Air outlet – do not obstruct
- Power supply and control connection
- Slings points

**NOTES:**

- Drawings are not contractually binding.
- Refer to unit nameplate for unit weight information
- Before designing an installation, consult the certified dimensional drawings, provided with the unit (Appendix 4).
- If the installation includes several units or if this (these) is (are) close to walls, please refer to chapters 3.7 - "Multiple chiller installation" and 3.8 - "Distance to the wall" of the installation manual to determine the space required

## DIMENSIONS / CLEARANCES

### 30XBEZE 0450 to 630, 30XBPZE 0450 to 0600

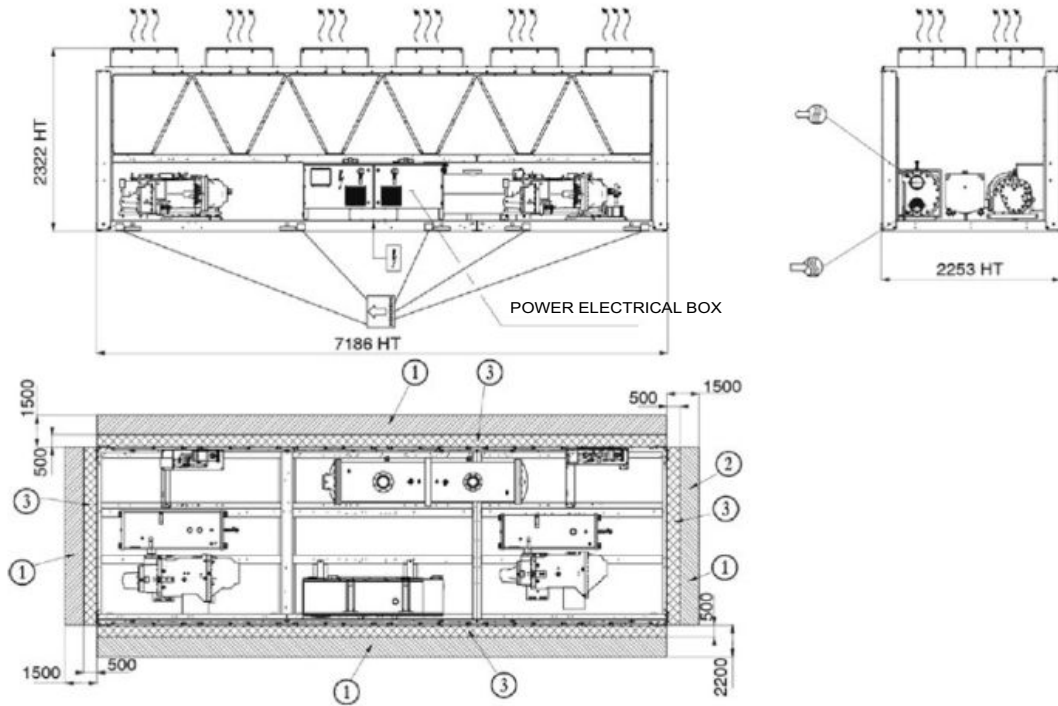

### 30XBEZE 0700 & 750, 30XBPZE 0630 & 700

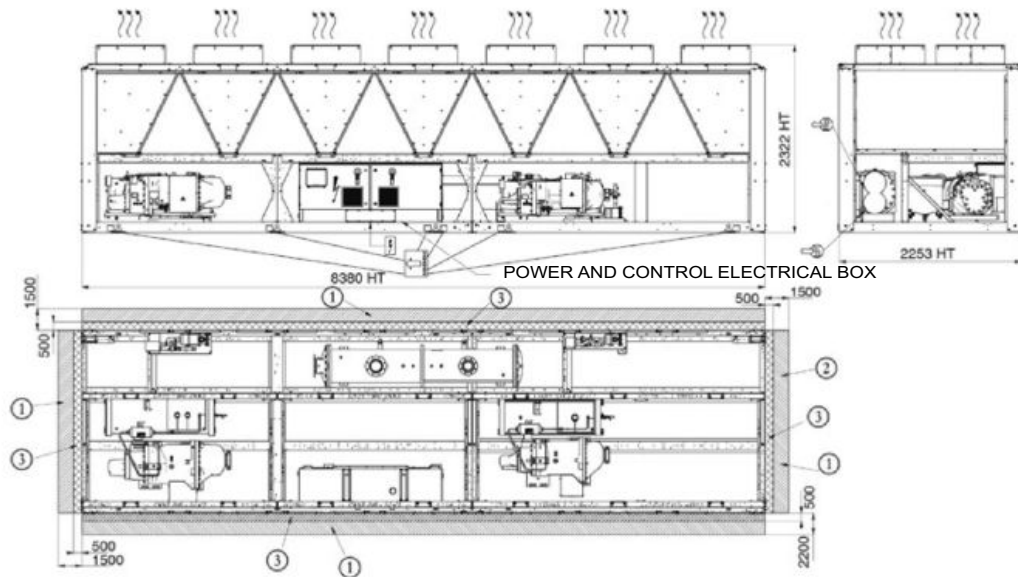

#### Legend

All dimensions are given in mm.

- ① Required clearances for maintenance (see note)
- ② Recommended space for evaporator tube removal
- ③ ATEX zone around the unit
- Water inlet for standard unit - for options 100A, 100C, 107 refer to the certified drawing.
- Water outlet for standard unit - for options 100A, 100C, 107 refer to the certified drawing.
- Air outlet – do not obstruct
- Power supply and control connection
- Slings points

#### NOTES:

- Drawings are not contractually binding.
- Refer to unit nameplate for unit weight information
- Before designing an installation, consult the certified dimensional drawings, provided with the unit (Appendix 4).
- If the installation includes several units or if this (these) is (are) close to walls, please refer to chapters 3.7 - "Multiple chiller installation" and 3.8 - "Distance to the wall" of the installation manual to determine the space required

## DIMENSIONS / CLEARANCES

### 30XBPZE 0750

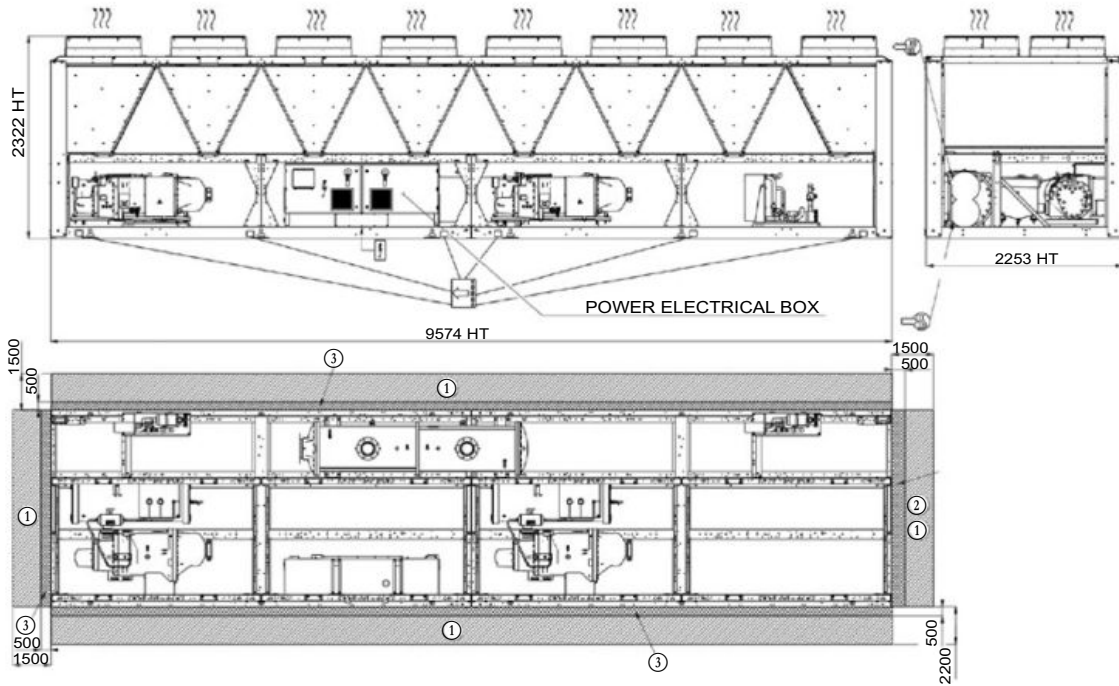

### 30XBEZE 0900 to 950

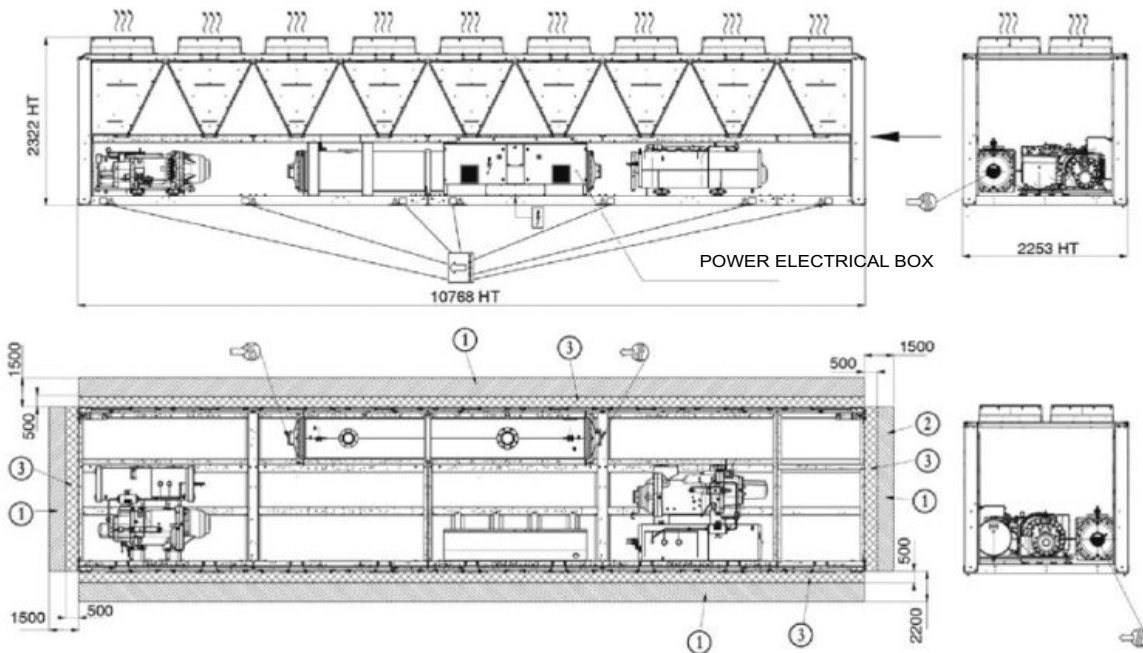

#### Legend

All dimensions are given in mm.

- ① Required clearances for maintenance (see note)
- ② Recommended space for evaporator tube removal
- ③ ATEX zone around the unit
- Water inlet for standard unit - for options 100A, 100C, 107 refer to the certified drawing.
- Water outlet for standard unit - for options 100A, 100C, 107 refer to the certified drawing.
- Air outlet – do not obstruct
- Power supply and control connection
- Slinging points

#### NOTES:

- Drawings are not contractually binding.
- Refer to unit nameplate for unit weight information
- Before designing an installation, consult the certified dimensional drawings, provided with the unit (Appendix 4).
- If the installation includes several units or if this (these) is (are) close to walls, please refer to chapters 3.7 - "Multiple chiller installation" and 3.8 - "Distance to the wall" of the installation manual to determine the space required



## DIMENSIONS / CLEARANCES

### 30XBEZE 1050 & 1150, 30XBPZE 0900 to 1150

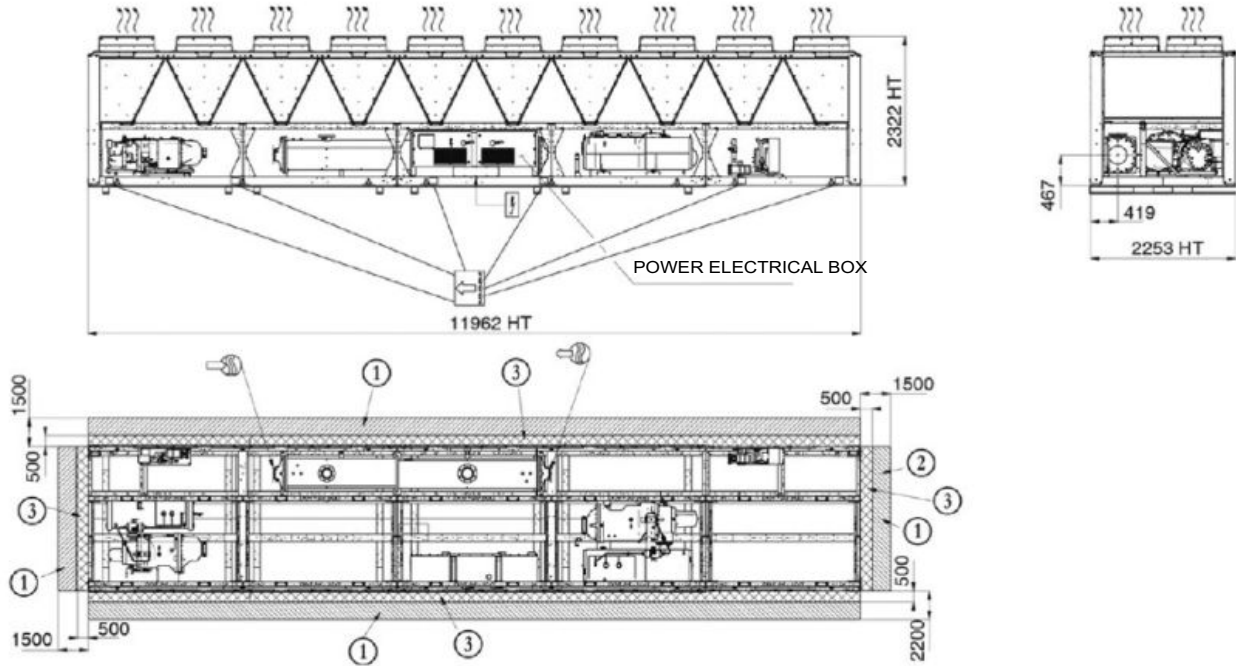

### 30XB(E/P)ZE 1200

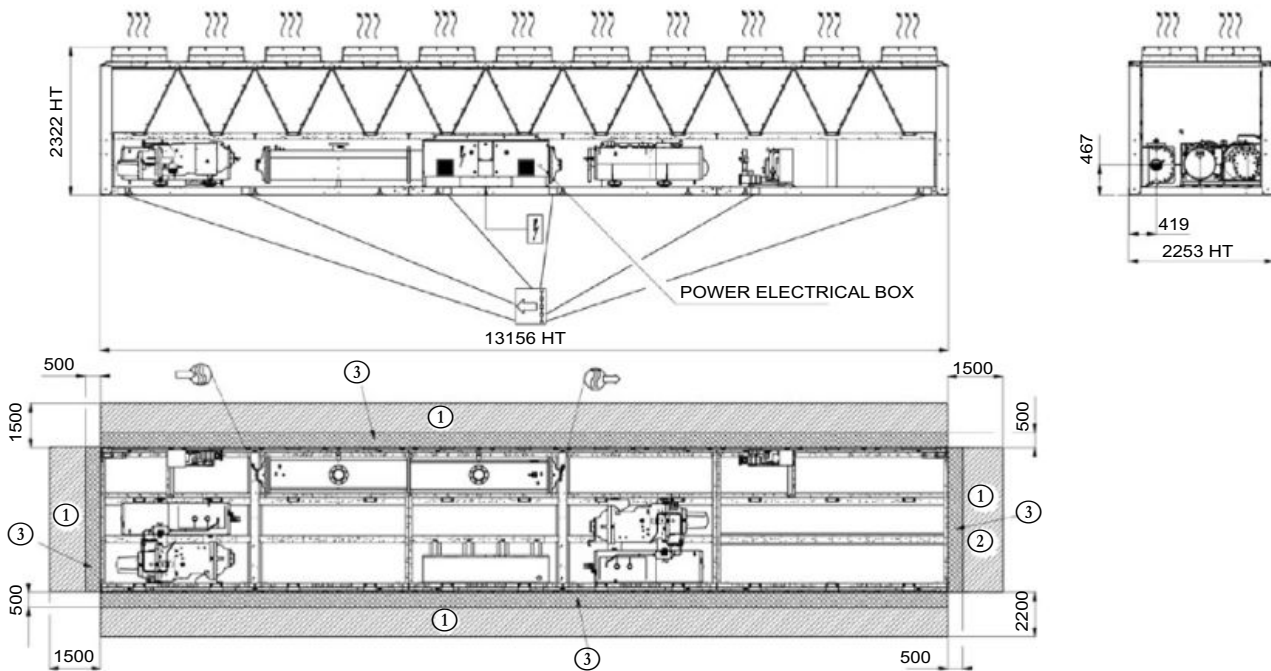

#### Legend

All dimensions are given in mm.

- ① Required clearances for maintenance (see note)
- ② Recommended space for evaporator tube removal
- ③ ATEX zone around the unit
- Water inlet for standard unit - for options 100A, 100C, 107 refer to the certified drawing.
- Water outlet for standard unit - for options 100A, 100C, 107 refer to the certified drawing.
- Air outlet – do not obstruct
- Power supply and control connection
- Slings points

#### NOTES:

- Drawings are not contractually binding.
- Refer to unit nameplate for unit weight information
- Before designing an installation, consult the certified dimensional drawings, provided with the unit (Appendix 4).
- If the installation includes several units or if this (these) is (are) close to walls, please refer to chapters 3.7 - "Multiple chiller installation" and 3.8 - "Distance to the wall" of the installation manual to determine the space required





## AIR-COOLED FIXED-SPEED SCREW CHILLER



- Very economical operation
- Low sound levels
- Simple installation
- Environmentally responsible
- Exceptional reliability

## 30XBE / 30XBP 250-1700



Nominal cooling capacity 277 - 1684 kW - 50 Hz

The AquaForce™ 30XBE and 30XBP liquid chillers are the economic solution for commercial and industrial applications where high reliability and economic operation in all climate conditions are key customer requirements.

The AquaForce™ 30XBE and 30XBP liquid chillers are designed to meet current and future regulations for energy efficiency and operating sound levels. They use the latest Carrier technologies:

Carrier 06T twin-rotor fixed-speed screw compressors.

Low noise 6th generation of Carrier Flying Bird™ fans with AC motor (30XBE) or EC motor (30XBP).

Carrier flooded shell-and-tube evaporator with new copper tube design for low pressure drops

2nd generation of "V" shape Carrier Novation™ microchannel heat exchangers with optional Enviro-Shield coatings.

Carrier SmartVu™ control with color touch screen user interface that includes 10 languages and integrated web-server.



CARRIER participates in the ECP programme for LCP-HP  
Check ongoing validity of certificate:  
[www.eurovent-certification.com](http://www.eurovent-certification.com)

## AQUAFORCE®, THE RIGHT SOLUTION FOR EVERY APPLICATION

Carrier's AquaForce® 30XBE range is available in two levels of efficiency to perfectly match each customer application and meet the European Ecodesign directive requirements.

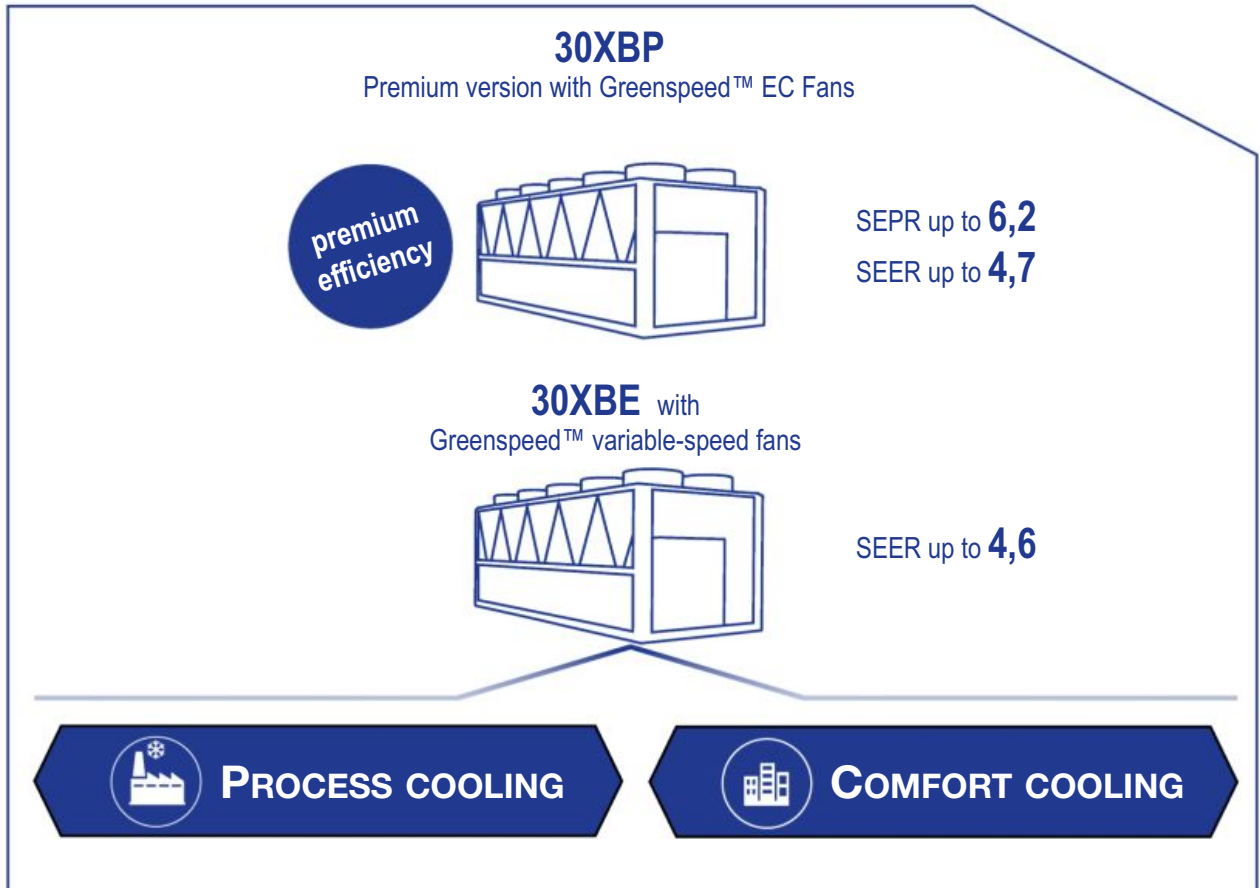

**30XBE**  
with Greenspeed™ intelligence

The AquaForce® 30XBE with Greenspeed™ intelligence is equipped with variable-speed AC fan motors. It offers an economical solution to enhance seasonal energy efficiency levels for comfort applications. The 30XBE with Greenspeed™ intelligence meets the 2021 EU Ecodesign SEER 12/7°C requirements (Application thermal load variation from 0% to 100%).



**30XBP**

The AquaForce® 30XBP with Greenspeed™ intelligence is the premium version with EC fans and additional heat exchange surface to improve both the full load and part load energy efficiency.

The 30XBP provides very cost effective operation in both process and comfort applications through the use of state of the art EC fan technology.

## 30XBE RANGES CUSTOMER BENEFITS

### ■ Absolute reliability

Carrier's AquaForce® 30XBE is the evolution of the 30XA range that counts thousands of installations worldwide. The reliability of the AquaForce® system is the result of intensive research, field experience combined with the highest quality standards. The AquaForce® range is equipped with the Carrier 06T twin screw compressors, well-known for its robustness, 99,7% of units without a compressor failure\*, and the fully aluminium Novation® microchannel heat exchangers with Super Enviro-shield™ coatings to deliver guaranteed long-term optimized performance.

\* Quality rate measured over a period of 15 years operation.



**99,7%**  
of units without a  
compressor failure



Up to  
**40% less**  
refrigerant charge



**25%**  
smaller



from  
**-20°C**  
to **55°C**



**93 dB(A)**

### ■ Environmental responsibility

Carrier's AquaForce® 30XBE ranges are a boost for green cities and contributes to a sustainable future. Combining a reduced load refrigerant (-40% vs traditional cu/al coils) thanks to the use of Novation® microchannel heat exchangers and high energy efficiency it significantly lowers energy consumption while reducing carbon dioxide emissions throughout its life cycle.

The AquaForce® PUREtec™ version, designed exclusively for ultra low GWP HFO R1234ze, are available.

### ■ Compact

Designed with one "V shape" Novation® microchannel heat exchanger less, Carrier's AquaForce® 30XBE is 25% smaller than the previous 30XA generation. As an example, the 30XBE -500 model is 1.2 meters shorter than the previous 30XA-502 model while offering same energy efficiency ratio.

### ■ Extensive scope of application

Carrier's AquaForce® 30XBE and 30XBP adapt effortlessly to a wide range of applications. Extended operating temperatures from -20°C to 55°C outdoor air temperatures and negative water temperatures make it ideal for various sectors of activity. From high-end office buildings and hotels to healthcare facilities, data centers and industrial projects, AquaForce® 30XBE and 30XBP are the perfect solutions to combine competitive price associated with high energy efficiency whatever the climate and wherever the location.

### ■ Low operating sound levels

The AquaForce® 30XBE and 30XBP range offers 4 sound levels to meet the most demanding technical requirements in noise sensitive environments. 30XBE is up to 6 dB(A) quieter than the AquaForce® 30XAV generation.

The range is equipped in standard with the 6th generation of Carrier Flying Bird fans. The new fan blade inspired by nature is the result of advanced research in our laboratory. The unit can be equipped in option with AC or EC motor to guarantee smooth fan speed variation and thus eliminate start-stop noise during part load operation.

For further acoustic comfort, the units can be equipped with an acoustic compressor and oil separator enclosure reducing radiated noise (option 15), with low speed fans (option 15LS) and with sound attenuation material on the refrigerating circuit to guarantee ultra-low noise operation for highly noise sensitive environment (option 15LS+).

## CUSTOMER BENEFITS

The range is available in 2 efficiency levels.

- 30XBE standard unit with variable speed AC fan motors  
The AquaForce™ 30XBE is equipped with fixed-speed screw compressors and variable-speed fans with AC motors. The 30XBE offers an economical solution to enhance seasonal energy efficiency levels for comfort applications.  
(Average SEPR of 5,7, average SEER of 4,6, average EER of 3,1)
- 30XBP premium unit  
The 30XBP premium unit is equipped with EC fans to improve both the full load and part load energy efficiency. The 30XBP provides very cost effective operation in both process and comfort applications through the use of state of the art EC fan technology.  
(Average SEPR of 6,0, average SEER of 4,7, average EER of 3.2)

### Very economical operation

- Exceptionally high full load and part load energy efficiency:
- 30XBE version: SEER 12/7°C up to 4.4 in accordance with EN14825.
  - 30XBP version: SEER 12/7°C up to 4.6 in accordance with EN14825.
  - Twin-rotor screw compressor equipped with a high-efficiency motor and a variable capacity valve that permits exact matching of the cooling capacity to the load.
  - Novation™ aluminium condenser with high-efficiency micro-channels.
  - Flooded shell-and-tube evaporator with new generation of cooler tubes to reduce exchanger pressure drops, especially in applications with high percentage of glycol.
  - Electronic expansion device permitting operation at a lower condensing pressure and improved utilisation of the evaporator heat exchange surface (superheat control).
  - Economiser system with electronic expansion device for increased cooling capacity.

### Low operating sound levels

- Compressors
  - Discharge dampers integrated in the oil separator (Carrier patent).
  - Silencer on the economiser return line.
  - Compressor and oil separator acoustic enclosure, reducing radiated noise (option).
- Condenser section
  - Condenser coils in wide angle V configuration, allowing quieter air flow across the coil
  - Low-noise 6<sup>th</sup> generation Flying Bird fans, made of a composite material (Carrier patent), are now even quieter and do not generate intrusive low-frequency noise
  - Inverter driven EC fans on 30XBP version eliminate start stop noise during part load operation.
  - Rigid fan mounting preventing start-up noise (Carrier patent).

## CUSTOMER BENEFITS

### Simple installation

- Integrated hydraulic module (option)
  - Centrifugal low or high-pressure water pump (as required), based on the pressure loss of the hydraulic installation
  - Single or dual pump (as required) with run time balancing and automatic changeover to the back-up pump if a fault develops
  - Water filter to protect pump against circulating debris
  - High-capacity membrane expansion tank ensures pressurisation of the water circuit (option)
  - Thermal insulation and aluminium cladding (option)
  - Pressure sensor to check filter condition and for direct numerical display of the water flow rate with an estimate of the instantaneous cooling capacity at the control interface
- Simplified electrical connections
  - Main disconnect switch with high trip capacity
  - Transformer to supply the integrated control circuit (400/24 V).
- Fast commissioning
  - Systematic factory operation test before shipment
  - Quick-test function for step-by-step verification of the controls, expansion devices, fans and compressors.

### Environmental responsibility

- R-134a refrigerant
  - Range designed for use with R-134a refrigerant with the possibility to upgrade to ultra-low global warming potential R-1234ze by using the dedicated field retrofit kit.
  - 40% reduction in the refrigerant charge through the use of micro-channel heat exchangers
- Leak-tight refrigerant circuit
  - Reduction of leaks as no capillary tubes and flare connections are used
  - Verification of pressure transducers and temperature sensors without transferring refrigerant charge
  - Liquid line service valve for simplified maintenance (option).

### Exceptional reliability

- Screw compressors
  - Industrial-type screw compressors with oversized bearings and motor cooled by suction gas.
  - All compressor components are easily accessible on site minimising down-time.
  - Dedicated electronic compressor protection module.
- Air condenser
  - 2<sup>nd</sup> generation of "V" shape Carrier Novation™ aluminium microchannel heat exchangers (MCHE) with high corrosion resistance. The all aluminium design eliminates the formation of galvanic currents between aluminium and copper that cause coil corrosion in saline or corrosive environments.
- Evaporator
  - Thermal insulation with aluminium sheet finish (option) for improved resistance to mechanical and UV damage.
- Auto-adaptive control
  - Control algorithm prevents excessive compressor cycling (Carrier patent)
  - Automatic compressor unloading in case of abnormally high condensing pressure. If condenser coil fouling or fan failure occurs, the Aquaforce continues to operate, but at reduced capacity
- Exceptional endurance tests
  - Partnerships with specialised laboratories and use of sophisticated finite element stress analysis for the design of critical components.
  - Transport simulation test in the laboratory on a vibrating table. The test is based on a military standard and equivalent to 4000 km by truck.
  - Salt mist corrosion resistance test in the laboratory for increased corrosion resistance.



## 30XB TECHNICAL INSIGHTS

PRESENTATION

COOLING

HEATING

AIR TREATMENT

CONTROLS



### 6TH GENERATION OF FLYING BIRD™ FANS WITH AC OR EC MOTOR

- Exclusive Carrier design
- Fan blade design inspired by nature
- 30XBE standard version with variable-speed fans and AC motor
- EC fans available as standard on 30XBP premium version



### 2ND GENERATION OF “V” SHAPE NOVATION® MICRO CHANNEL HEAT EXCHANGERS

- Exclusive Carrier design
- High reliability with long-life aluminum alloy
- Significantly reduces refrigerant load (~40% vs cu/al coils)
- Enviro-shield™ coating for mildly corrosive environments
- Super Enviro-shield™ coating for highly corrosive environments (industry or marine applications)



### FIXED-SPEED SINGLE OR DUAL PUMPS WITH AC MOTOR (OPTION)

- Low static pressure (~100 kPa) or high static pressure (~180 kPa) available
- Available on all sizes up to 400 kW



### CARRIER FIXED-SPEED 06T TWIN SCREW COMPRESSOR WITH AC MOTOR

- Exclusive Carrier design
- Twin screw compressor designed for fixed speed operation
- Sliding valve control (30%-100%)
- Bearing life exceeding 100,000 hours
- 99,7% of units without compressor default

### FLOODED SHELL AND TUBE EVAPORATOR

- Exclusive Carrier design
- Flooded technology for high energy efficiency
- New generation of copper tubes with specific profile to reduce pressure drops when operating with glycol

### ADVANCED SMARTVU™ WITH 5 INCH COLOR TOUCH SCREEN INTERFACE

- Exclusive Carrier design
- 10 languages available: DE, EN, ES, FR, IT, NL, PT, TR, TU + one additional customer choice
- Touch screen user interface
- BACnet, J-Bus or LON communication interfaces
- Optional wireless connectivity
- Web server capabilities-easy remote access via internet
- Trending capabilities

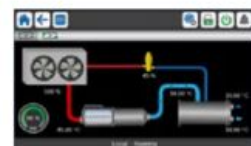

## TECHNICAL INSIGHTS

### SmartVu™ Control

SmartVu™, user interface

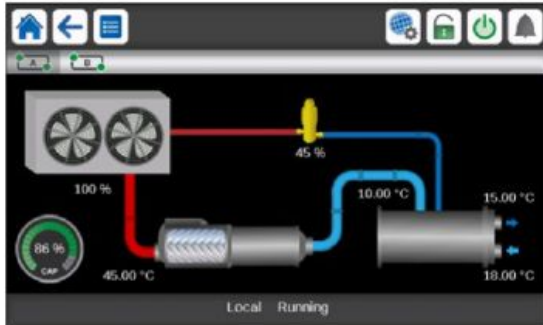

- New innovative smart control features:
  - An intuitive and user-friendly, coloured, 5" interface (7» optional)
  - Direct access to the unit's technical drawings and the main service documents
  - Screen-shots with concise and clear information in local languages
  - Complete menu, customised for different users (end user, service personnel and Carrier-factory technicians)
  - Easy access to the control panel with inclined touch screen mounting to ensure legibility under any lighting conditions
  - Safe operation and unit setting: password protection ensures that unauthorised people cannot modify any advanced parameters
  - Simple and «smart» intelligence uses data collection from the constant monitoring of all machine parameters to optimise unit operation.
- Energy management:
  - Internal time schedule clock controls chiller on/off times and operation at a second set-point
  - The DCT (Data Collection Tool) records the alarms history to simplify and facilitate service operations.

### Remote Management (Standard)

- Units with SmartVu™ control can be easily accessed from the internet, using a PC with an Ethernet connection. This makes remote control quick and easy and offers significant advantages for service operations.
- Aquaforce is equipped with an RS485 serial port that offers multiple remote control, monitoring and diagnostic possibilities. When networked with other Carrier equipment through the CCN (Carrier Comfort Network - proprietary protocol), and in conjunction with one of Carrier's network products (Chiller System Manager or Plant system Manager) it forms part of a fully integrated and balanced HVAC system (optional).
- Aquaforce also communicates with other building management systems via optional communication gateways.

- The following commands/visualisations are possible from remote connection:
  - Start/stop of the machine
  - Dual set-point management: through a dedicated contact is possible to activate a second set-point (for example, during unoccupied mode).
  - Demand limit setting: to limit the maximum chiller capacity to a predefined value
  - Water pump control: these outputs control the contactors of one/two evaporator water pumps
  - Automatic changeover of pumps in the event of a fault (only with options 116S/116U).
  - Operation visualisation: indication if the unit is operating or in stand-by (no cooling load), (no cooling load) - alarm visualisation.

### Remote Management (EMM option)

- The Energy Management Module (EMM) offers extended remote control possibilities:
  - Room temperature: Permits set-point reset based on the building indoor air temperature (if Carrier thermostat are installed)
  - Set-point reset: Allows reset of the cooling set-point based on a 4-20 mA or 0-10 V signal
  - Demand limit: Permits limitation of the maximum chiller capacity based on 0-10 V signal
  - Demand limit 1 and 2: Closing of these contacts limits the maximum chiller capacity to two predefined values
  - User safety: This contact can be used for any customer safety loop; opening the contact generates a specific alarm
  - Ice storage end: When ice storage has finished, this input permits return to the second set-point (unoccupied mode)
  - Time schedule override: closing this contact cancels the programmed time schedule.
  - Out of service: This signal indicates that the chiller is completely out of service
  - Chiller capacity: This analogue output (0-10 V) gives an immediate indication of the chiller capacity
  - Alert indication: This volt-free contact indicates the necessity to carry out a maintenance operation or the presence of a minor fault
  - Compressors running status: Set of outputs (one for each compressor) indicating which compressors are running.

## TECHNICAL INSIGHTS

### 06T Screw Compressor

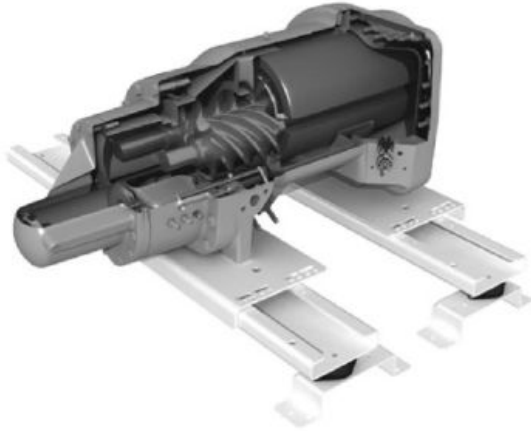

#### 99.7%\* of units without a compressor failure

\* Quality rate measured over a period of 15 years operation

The Carrier 06T screw compressor benefits from Carrier's long experience in the development of twin-rotor screw compressors. The compressor is equipped with bearings with oversized rollers, oil pressure lubricated for reliable and durable operation, even at maximum load.

A variable control valve controlled by the oil pressure permits infinitely variable cooling capacity. This system allows optimal adjustment of the compressor cooling capacity and ensures exceptionally high stability of the chilled water leaving temperature.

Among the other advantages: if a fault occurs e.g. if the condenser is fouled or at very high outside temperature, the compressor does not switch off, but continues operation with a reduced capacity (unloaded mode).

The compressor is equipped with a separate oil separator that minimises the amount of oil in circulation in the refrigerant circuit and, with its integrated silencer, considerably reduces discharge gas pulsations for much quieter operation.

### Novation® Heat Exchangers with Micro-Channel coil Technology

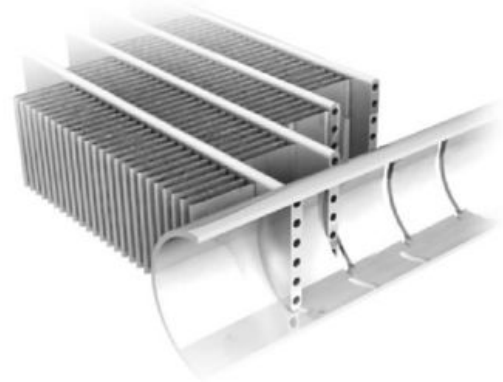

Already utilised in the automobile and aeronautical industries for many years, the Novation™ MCHE micro-channel heat exchanger used in the Aquaforce is entirely made of aluminium. This one-piece concept significantly increases its corrosion resistance by eliminating the galvanic currents that are created when two different metals (copper and aluminium) come into contact in traditional heat exchangers. Unlike traditional heat exchangers the Novation™ MCHE heat exchanger can be used in moderate marine and urban environments (Carrier recommendation).

From an energy efficiency point-of-view the Novation™ MCHE heat exchanger is approximately 10% more efficient than a traditional coil and allows a 40% reduction in the amount of refrigerant used in the chiller. The low thickness of the Novation™ MCHE reduces air pressure losses by 50% and makes it susceptible to very little fouling (e.g. by sand). Cleaning of the Novation™ MCHE heat exchanger is very fast using a high-pressure washer.

Carrier Novation® MCHE with Super Enviro-shield® coating, the ideal customer choice

To further enhance long-term performance, and to protect coils from early deterioration, Carrier offers (as options) dedicated treatments for installations in corrosive environments.

The Novation™ MCHE with Enviro-Shield protection (option 262) are recommended for installations in moderately corrosive environments. The Enviro-Shield protection utilises corrosion inhibitors which actively arrest oxidation in case of mechanical damage.

The Novation™ MCHE with the exclusive Super Enviro-Shield protection (option 263) are recommended for installations in corrosive environments. The Super Enviro-Shield protection consist in an extremely durable and flexible epoxy coating uniformly applied over all coil surfaces for complete isolation from the contaminated environment.

## TECHNICAL INSIGHTS

### Novation® Heat Exchangers with Micro-Channel coil Technology

After a total of more than 7,000 hours of testing following various test standards in UTC laboratories, the Carrier Novation® MCHE with Super Enviro-shield® coating appears to be the ideal customer choice to minimize the harmful effects of corrosive atmospheres and ensure long equipment life.

- Best corrosion resistance per ASTM B117/D610 test
- Best heat transfer performance per Carrier Marine 1 test
- Proven reliability per ASTM B117 test

Coil Types (ranked by performance)	Visual Corrosion Evaluation	Heat Transfer Performance Degradation	Time to Failure	Test Campaign Conclusions
Super Enviro-shield® Novation™ MCHE	Very good	Very good	No coil leak	Best
Super Enviro-shield® Cu/Al coil	Very good	Good	No coil leak	Very good
Enviro-shield® Novation™ MCHE	Very good	Good	No coil leak	Very good
Al/Al coil	Very good	Good	No coil leak	Very good
Novation™ MCHE	Good	Good	No coil leak	Good
Cu/Cu coil	Good	Good	Leak	Acceptable
Blygold® Cu/Al coil	Good	Good	No coil leak	Acceptable
Precoat Cu/Al coil	Bad	Bad	No coil leak	Bad
Cu/Al coil	Bad	Bad	No coil leak	Bad

### New Generation of Flying Bird VI fans with EC motor



The 30XBE and 30XBP utilize Carrier's 6<sup>th</sup> generation Flying Bird™ fan technology, engineered for maximum efficiency, super low noise, and wide operating range. The fan includes Carrier patented rotating shroud technology and back-swept blades with a unique wave-serration trailing edge inspired from nature.

It was designed and optimized for the 30XB ranges air management system configuration and heat exchanger technology and is offered with induction and EC motor options. The fan meets the latest European eco-design requirements for fan efficiency. The fan uses Carrier's robust and proven injection molded composite-thermoplastic construction.



## OPTIONS

Options	No.	Description	Advantages	Use for 30XBE / 30XBP
Corrosion protection, traditional coils	3A	Fins made of pre-treated aluminum (polyurethane and epoxy)	Improved corrosion resistance, recommended for moderate marine and urban environments	30XBE/30XBP 250-1700
Medium-temperature brine solution	5	Implementation of new control algorithms and redesigned evaporator to allow chilled brine solution production down to -12°C when ethylene glycol is used (-8°C with propylene glycol)	Covers specific applications such as ice storage and industrial processes	30XBE/30XBP 250-1700
Low-temperature brine solution	6	Implementation of new control algorithms and redesigned evaporator to allow chilled brine solution production down to -15°C when ethylene glycol is used (-10°C with propylene glycol)	Covers specific applications such as ice storage and industrial processes	30XBE/30XBP 250-1700
Light-brine solution, down to -3°C	8	Implementation of new control algorithms to allow chilled brine solution production down to -3°C when ethylene glycol is used (0°C with propylene glycol)	Matches with most application requirements for ground-sourced heat pumps and fits with many industrial processes requirements	30XBE/30XBP 250-1700
Unit equipped for air discharge ducting	10	Fans equipped with discharge connection flanges - maximum available pressure 60 Pa	Facilitates connections to the discharge ducts	30XBE/30XBP 250-1700
Low noise level	15	Aesthetic and sound absorbing compressor enclosure	Noise level reduction	30XBE/30XBP 250-1700
Very low noise level	15LS	Aesthetic and sound absorbing compressor enclosure associated with low-speed fans	Noise level reduction in sensitive environments	30XBE/30XBP 250-1700
Ultra low noise level	15LS+	Acoustic compressor enclosure, low-speed fans and enhanced sound insulation of main noise sources	Noise level reduction in sensitive environments	30XBE/30XBP 250-1700
IP54 control box	20A	Increased leak tightness of the unit	Protects the inside of the electrical box from dust, water and sand. In general this option is recommended for installations in polluted environments	30XBE/30XBP 250-1700
Tropicalisation of the electrical box	22	Electrical box equipped with an electrical heater and a fan. Electrical connections on the compressors painted with a special varnish and covered with an anti-condensation foam.	Allows safe operation in typical "tropical" climate. This option is recommended for all applications where humidity inside the electrical box can reach 80% at 40°C and unit can remain in stand-by for a long time under these conditions.	30XBE/30XBP 250-1700
Grilles and enclosure panels	23	Metal grilles on the 4 unit sides, plus side enclosure panels at each end of each coil	Improves aesthetics, protection against intrusion to the unit interior, coil and piping protection against impacts.	30XBE/30XBP 250-1700
Enclosure panels	23A	Side enclosure panels at each end of each coil	Improves aesthetics, coil and piping protection against impacts.	30XBE/30XBP 250-1700
Low inrush current	25C	Specific compressor loading and unloading sequence to limit the unit start-up current	Reduced start-up current	30XBE/30XBP 250-1700
Water exchanger frost protection	41A	Electric resistance heater on the water exchanger and discharge valve	Water exchanger frost protection down to -20°C outside temperature	30XBE/30XBP 250-1700
Evaporator & hydraulic module frost protection	41B	Electric resistance heater on water exchanger, discharge valve and hydraulic module	Water exchanger and hydraulic module frost protection down to -20°C outside temperature	30XBE/30XBP 250-500
Total heat recovery	50	Unit equipped with additional heat exchanger in parallel with the condenser coils.	Production of free hot-water simultaneously with chilled water production	30XBE/30XBP 250-1000
Master/slave operation	58	Unit equipped with supplementary water outlet temperature sensor kit (to be field installed) allowing master/slave operation of two units connected in parallel	Optimised operation of two units connected in parrallele operation with operating time equalisation	30XBE/30XBP 250-400
Single power connection point	81	Unit power connection via one main supply connection	Quick and easy installation	30XBE/30XBP 1100-1500
Evap. and pumps with aluminum jacket	88A	Evaporator and pumps covered with an aluminum sheet for thermal insulation protection	Improved resistance to aggressive climate conditions	30XBE/30XBP 250-400
Service valve set	92	Liquid line valve (evaporator inlet), compressor suction and discharge line valves and economiser line valve	Allow isolation of various refrigerant circuit components for simplified service and maintenance	30XBE/30XBP 250-1700



## OPTIONS

Options	No.	Description	Advantages	Use for 30XBE / 30XBP
Compressor discharge valves	93A	Shut-off valve on the compressor discharge piping	Simplified maintenance	30XBE/30XBP 250-1700
Evaporator with one pass more	100A	Evaporator with one pass more on the water side	Optimise chiller operation when the chilled water circuit is designed with low waterflows (high evaporator delta T)	30XBE/30XBP 250-1700
21 bar evaporator	104	Reinforced evaporator for extension of the maximum water-side service pressure to 21 bar (standard 10 bar)	Covers applications with a high water column evaporator side (typically high-rise buildings)	30XBE/30XBP 250-1700
Reversed evaporator water connections	107	Evaporator with reversed water inlet/outlet	Easy installation on sites with specific requirements	30XBE/30XBP 250-1700
HP single-pump hydraulic module	116R	Hydraulic module equipped with water filter, one high pressure pump, drain valve and pressure transducers (expansion tank & aluminum jacket not included).	Easy and fast installation (plug & play). Increased system reliability	30XBE/30XBP 250-400
HP dual-pump hydraulic module	116S	Hydraulic module equipped with water filter, two high pressure pumps, drain valve and pressure transducers (expansion tank & aluminum jacket not included).	Easy and fast installation (plug & play). Increased system reliability	30XBE/30XBP 250-400
LP single-pump hydraulic module	116T	Hydraulic module equipped with water filter, one low pressure pump, drain valve and pressure transducers (expansion tank & aluminum jacket not included).	Easy and fast installation (plug & play). Increased system reliability	30XBE/30XBP 250-400
LP dual-pump hydraulic module	116U	Hydraulic module equipped with water filter, two low pressure pumps, drain valve and pressure transducers (expansion tank & aluminum jacket not included).	Easy and fast installation (plug & play). Increased system reliability	30XBE/30XBP 250-400
Dx Free Cooling system on two circuits	118A	Patented Carrier free-cooling system with cooling micro-pump on both refrigerant circuits. Operation without glycol, no extra free-cooling coil. See Dx Free-cooling option chapter	Energy savings for applications with cooling demand throughout the entire year	30XBE/30XBP 250-1000
Lon gateway	148D	Bi-directional communication board complying with Lon Talk protocol	Connects the unit by communication bus to a building management system	30XBE/30XBP 250-1700
Bacnet over IP	149	Bi-directional high-speed communication using BACnet protocol over Ethernet network (IP)	Easy and high-speed connection by ethernet line to a building management system. Allows access to multiple unit parameters	30XBE/30XBP 250-1700
Modbus over IP and RS485 communication gateway	149B	Bi-directional high-speed communication using the Modbus over Ethernet network (IP) protocol	Easy, quick connection via Ethernet line to a building technical management system. Allows access to several unit parameters.	30XBE/30XBP 250-1700
Energy Management Module	156	EMM Control board with additional inputs/ outputs. See Energy Management Module option chapter	Extended remote control capabilities (Set-point reset, ice storage end, demand limits, boiler on/off command...)	30XBE/30XBP 250-1700
7" user interface	158A	Control supplied with a 7 inch colour touch screen user interface	Enhanced ease of use.	30XBE/30XBP 250-1700
Input contact for Refrigerant leak detection	159	0-10 V signal to report any refrigerant leakage in the unit directly on the controller (the leak detector itself must be supplied by the customer)	Immediate customer notification of refrigerant losses to the atmosphere, allowing timely corrective actions	30XBE/30XBP 250-1700
Dual relief valves on 3-way valve	194	Three-way valve upstream of dual relief valves on the evaporator and the oil separator	Valve replacement and inspection facilitated without refrigerant loss. Comforms to European standard EN378/BGVD4	30XBE/30XBP 250-1700
Compliance with Swiss regulations	197	Additional tests on the water heat exchangers: supply (additional of PED documents) supplementary certificates and test certifications	Conformance with Swiss regulations	30XBE/30XBP 250-1700
Compliance with Russian regulations	199	EAC certification	Conformance with Russian regulations	30XBE/30XBP 250-1700

## OPTIONS

Options	No.	Description	Advantages	Use for 30XBE / 30XBP
Compliance with Australian regulations	200	Unit approved to Australian code	Conformance with Australian regulations	30XBE/30XBP 250-1700
Insulation of the evap. in/out ref.lines	256	Thermal insulation of the evaporator entering/leaving refrigerant lines with flexible, UV resistant insulation	Prevents condensation on the evaporator entering/leaving refrigerant lines	30XBE/30XBP 250-1700
Enviro-Shield anti-corrosion protection	262	Coating by conversion process which modifies the surface of the aluminum producing a coating that is integral to the coil. Complete immersion in a bath to ensure 100% coverage. No heat transfer variation, tested 4000 hours salt spray per ASTM B117	Improved corrosion resistance, recommended for use in moderately corrosive environments	30XBE/30XBP 250-1700
Super Enviro-Shield anti-corrosion protection	263	Extremely durable and flexible epoxy polymer coating applied on micro channel heat exchangers by electro coating process, final UV protective topcoat. Minimal heat transfer variation, tested 6000 hours constant neutral salt spray per ASTM B117, superior impact resistance per ASTM D2794	Improved corrosion resistance, recommended for use in extremely corrosive environments	30XBE/30XBP 250-1700
Welded evaporator connection kit	266	Victaulic pipe adapters for welded joints	Easy installation	30XBE/30XBP 250-1700
Compressor enclosure	279a	Compressor enclosure	Improved aesthetic, compressor protection against external elements (dust, sand, water...)	30XBE/30XBP 250-1700
Evaporator with aluminum jacket	281	Evaporator covered with an aluminum sheet for thermal insulation protection	Improved resistance to aggressive climate conditions	30XBE/30XBP 250-1700
230V electrical plug	284	230V AC power supply source provided with plug socket and transformer (180 VA, 0,8 Amps)	Permits connection of a laptop or an electrical device during unit commissioning or servicing	30XBE/30XBP 250-1700
Expansion tank	293	6 bar expansion tank integrated in the hydraulic module (requires hydraulic module option)	Easy and fast installation (plug & play), & Protection of closed water systems from excessive pressure	30XBE/30XBP 250-400
US screw compressor	297	Screw compressor made in US		30XBE/XBP 1100-1700
Variable Water Flow control	299	Hydraulic control function package that permits control of the water flow rate based on different possible logics (at customer choice): constant $\Delta T$ , constant outlet pressure and "fixed-speed" control	When variable-speed pumps on the primary circuit, the VWF control modulates flow rate through the evaporator, minimising pump consumption while ensuring safe/optimised chiller operation	30XBE/XBP 250-400
Free-cooling dry-cooler control	313	Remote control of 09PE or 09VE dry-cooler based on a 0-10V signal.	Easy system management, extended control capabilities of a remote dry-cooler used in free-cooling mode	30XBE/XBP 250-1700
Compliance with UAE regulation	318	Additional label on the unit with rated power input, rated current and EER following AHRI 550/590	Compliance with ESMA standard UAE.S 5010-5 :2019.	30XBE/30XBP 250-1700
Compliance with Qatar regulation	319	Specific nameplate on the unit with power supply 415 V+/-6%	Compliance with KAHRAMAA regulation in Qatar.	30XBE/30XBP 250-1700
Compliance with Morocco regulation	327	Specific documents according Morocco regulation	Conformance with Morocco regulations	30XBE/30XBP 250-1700
Plastic tarp	331	Plastic tarp covering units with strapping and camped on the wooden pallet.	Allow unit to avoid dust and dirt from the outside environment during stocking and shipping.	30XBE/30XBP 250-1700

## PHYSICAL DATA, SIZES 30XBE-250 TO 800

30XBE			250	300	350	400	450	500	600	700	750	800	
<b>Cooling</b>													
<b>Standard unit</b> Full load performances*	CA1	Nominal capacity	kW	277	300	322	392	444	494	623	676	730	782
		EER	kW/kW	3,15	3,12	3,08	3,18	3,11	3,08	3,22	3,28	3,10	3,10
<b>Unit with option 15LS (+)</b> Full load performances*	CA1	Nominal capacity	kW	271	293	313	384	432	478	607	659	709	757
		EER	kW/kW	3,13	3,08	3,00	3,16	3,03	2,93	3,13	3,20	2,97	2,93
Seasonal energy efficiency **		<b>SEER <sub>12/7°C</sub> Comfort low temp.</b>	<b>kWh/kWh</b>	<b>4,47</b>	<b>4,46</b>	<b>4,40</b>	<b>4,33</b>	<b>4,56</b>	<b>4,55</b>	<b>4,55</b>	<b>4,62</b>	<b>4,56</b>	<b>4,55</b>
		<b>η<sub>s</sub> cool <sub>12/7°C</sub></b>	<b>%</b>	<b>176</b>	<b>175</b>	<b>173</b>	<b>170</b>	<b>179</b>	<b>179</b>	<b>179</b>	<b>182</b>	<b>179</b>	<b>179</b>
		<b>SEPR <sub>12/7°C</sub> Process high temp.</b>	<b>kWh/kWh</b>	<b>5,70</b>	<b>5,69</b>	<b>5,65</b>	<b>5,78</b>	<b>5,72</b>	<b>5,74</b>	<b>5,68</b>	<b>5,79</b>	<b>5,63</b>	NA
<b>Unit with Option 5</b> Seasonal energy efficiency **		<b>SEPR <sub>-2/-8°C</sub> Process medium temp.***</b>	<b>kWh/kWh</b>	<b>2,72</b>	<b>3,02</b>	<b>3,18</b>	<b>2,81</b>	<b>3,51</b>	<b>3,56</b>	<b>3,65</b>	<b>3,67</b>	<b>3,44</b>	<b>3,35</b>
<b>Unit with Option 299</b> Seasonal energy efficiency **		<b>SEER <sub>12/7°C</sub> Comfort low temp.</b>	<b>kWh/kWh</b>	<b>4,47</b>	<b>4,47</b>	<b>4,43</b>	<b>4,49</b>	NA	NA	NA	NA	NA	NA
		<b>η<sub>s</sub> cool <sub>12/7°C</sub></b>	<b>%</b>	<b>176</b>	<b>176</b>	<b>174</b>	<b>177</b>	NA	NA	NA	NA	NA	NA
		<b>SEPR <sub>12/7°C</sub> Process high temp.</b>	<b>kWh/kWh</b>	<b>5,72</b>	<b>5,71</b>	<b>5,68</b>	<b>5,83</b>	NA	NA	NA	NA	NA	NA
<b>Unit with Option 6</b> Seasonal energy efficiency **		<b>SEPR <sub>-2/-8°C</sub> Process medium temp.***</b>	<b>kWh/kWh</b>	<b>3,29</b>	<b>3,46</b>	<b>3,52</b>	<b>3,26</b>	<b>3,42</b>	<b>3,5</b>	<b>3,5</b>	<b>3,62</b>	<b>3,38</b>	<b>3,34</b>
<b>Unit with 15LS (+)</b> Seasonal energy efficiency **		<b>SEER <sub>12/7°C</sub> Comfort low temp.</b>	<b>kWh/kWh</b>	<b>4,49</b>	<b>4,48</b>	<b>4,41</b>	<b>4,33</b>	<b>4,56</b>	<b>4,57</b>	<b>4,56</b>	<b>4,62</b>	<b>4,56</b>	<b>4,58</b>
		<b>η<sub>s</sub> cool <sub>12/7°C</sub></b>	<b>%</b>	<b>176</b>	<b>176</b>	<b>173</b>	<b>170</b>	<b>179</b>	<b>180</b>	<b>179</b>	<b>182</b>	<b>179</b>	<b>180</b>
		<b>SEPR <sub>12/7°C</sub> Process high temp.</b>	<b>kWh/kWh</b>	<b>5,82</b>	<b>5,88</b>	<b>5,79</b>	<b>5,57</b>	<b>5,70</b>	<b>5,79</b>	<b>5,92</b>	<b>5,93</b>	<b>5,79</b>	<b>5,72</b>
<b>Unit with Option 5 &amp; 15LS (+)</b> Seasonal energy efficiency **		<b>SEPR <sub>-2/-8°C</sub> Process medium temp.***</b>	<b>kWh/kWh</b>	<b>2,75</b>	<b>3,10</b>	<b>3,29</b>	<b>2,83</b>	<b>3,54</b>	<b>3,67</b>	<b>3,79</b>	<b>3,82</b>	<b>3,55</b>	<b>3,57</b>
<b>Unit with Option 299 &amp; 15LS (+)</b> Seasonal energy efficiency **		<b>SEER <sub>12/7°C</sub> Comfort low temp.</b>	<b>kWh/kWh</b>	<b>4,47</b>	<b>4,47</b>	<b>4,42</b>	<b>4,47</b>	NA	NA	NA	NA	NA	NA
		<b>η<sub>s</sub> cool <sub>12/7°C</sub></b>	<b>%</b>	<b>176</b>	<b>176</b>	<b>174</b>	<b>176</b>	NA	NA	NA	NA	NA	NA
		<b>SEPR <sub>12/7°C</sub> Process high temp.</b>	<b>kWh/kWh</b>	<b>5,84</b>	<b>5,91</b>	<b>5,82</b>	<b>5,61</b>	NA	NA	NA	NA	NA	NA
<b>Unit with Option 6 &amp; 15LS(+)</b> Seasonal energy efficiency **		<b>SEPR <sub>-2/-8°C</sub> Process medium temp.***</b>	<b>kWh/kWh</b>	<b>3,35</b>	<b>3,58</b>	<b>3,71</b>	<b>3,38</b>	<b>3,64</b>	<b>3,61</b>	<b>3,63</b>	<b>3,78</b>	<b>3,50</b>	<b>3,55</b>
<b>Sound levels</b>													
<b>Standard unit</b>													
Sound power <sup>(1)</sup>		dB(A)	99	99	99	99	101	99	101	99	103	103	
Sound pressure at 10 m <sup>(2)</sup>		dB(A)	67	67	67	67	69	67	68	66	70	70	
<b>Unit + option 15<sup>(3)</sup></b>													
Sound power <sup>(1)</sup>		dB(A)	93	93	94	95	95	95	97	96	97	98	
Sound pressure at 10 m <sup>(2)</sup>		dB(A)	61	61	62	63	63	63	64	63	64	65	
<b>Unit + option 15LS<sup>(3)</sup></b>													
Sound power <sup>(1)</sup>		dB(A)	87	87	87	90	91	91	93	92	94	94	
Sound pressure at 10 m <sup>(2)</sup>		dB(A)	55	55	55	58	59	59	60	59	61	61	
<b>Unit + option 15LS+<sup>(3)</sup></b>													
Sound power <sup>(1)</sup>		dB(A)	-	-	-	-	89	89	91	90	91	92	
Sound pressure at 10 m <sup>(2)</sup>		dB(A)	-	-	-	-	57	57	58	57	58	59	
<b>Dimensions</b>													
<b>Standard unit</b>													
Length		mm	3604	3604	3604	4798	4798	4798	7186	7186	7186	7186	
Width		mm	2253	2253	2253	2253	2253	2253	2253	2253	2253	2253	
Height		mm	2322	2322	2322	2322	2322	2322	2322	2322	2322	2322	

\* In accordance with standard EN14511-3:2022.

\*\* In accordance with standard EN14825:2022, average climate

\*\*\* With EG 30%

 CA1 Cooling mode conditions: Evaporator water entering/leaving temperature 12°C/7°C, outside air temperature 35°C, evaporator frosting factor 0 m<sup>2</sup>.K/W

 η<sub>s</sub> cool<sub>12/7°C</sub> & SEER<sub>12/7°C</sub> **Bold values compliant to Ecodesign regulation: (EU) No 2016/2281 for Comfort application**

 SEPR<sub>-2/-8°C</sub> **Bold values compliant to Ecodesign regulation: (EU) No 2015/1095 for Process application**

NA Non Authorized for the specific application for CEE market

 (1) in dB ref=10<sup>-12</sup> W, 'A' weighted. Declared dual-number noise emission values in accordance with ISO 4871 with an associated uncertainty of +/-3dB(A). Measured in accordance with ISO 9614-1 and certified by Eurovent.

 (2) In dB ref20μPa, 'A' weighted. Declared dual-number noise emission values in accordance with ISO 4871 with an associated uncertainty of +/-3dB(A). For information, calculated from the sound power L<sub>w</sub>(A).

(3) Options : 15 = Low noise, 15LS = Very Low noise, 118a = DX freecooling option, 50= heat recovery.



Eurovent certified values

## PHYSICAL DATA, SIZES 30XBE-250 TO 800

30XBE		250	300	350	400	450	500	600	700	750	800
<b>Operating weight<sup>(4)</sup></b>											
Standard unit	l	3040	3071	3091	3674	3737	3798	4797	4943	5201	5514
Unit + option 15 <sup>(3)</sup>	l	3308	3339	3359	3973	4036	4097	5128	5274	5532	5845
Unit + option 118 a <sup>(3)</sup>		3124	3155	3175	3778	3841	4182	4929	5075	5348	5661
Unit + option 50 <sup>(3)</sup>		3385	3417	3437	4106	4248	4590	5550	5696	6056	6368
<b>Compressors</b>											
06T semi-hermetic screw compressor, 50 r/s											
Circuit A		1	1	1	1	1	1	1	1	1	1
Circuit B		1	1	1	1	1	1	1	1	1	1
No. of control stages											
<b>Refrigerant<sup>(4)</sup></b>											
R134a											
Circuit A	kg	39	37	37	52	53	55	60	61	69	69
	teqCO <sub>2</sub>	55,8	52,9	52,9	74,4	75,8	77,9	85,8	87,2	98,0	98,7
Circuit B	kg	40	38	39	40	40	37	61	64	61	67
	teqCO <sub>2</sub>	57,2	54,3	55,8	57,2	57,2	52,9	87,2	91,5	86,5	95,8
<b>Oil</b>											
Circuit A	l	20,8	20,8	20,8	23,5	23,5	23,5	23,5	23,5	27,6	27,6
Circuit B	l	20,8	20,8	20,8	20,8	20,8	20,8	23,5	23,5	23,5	23,5
Capacity control		SmartVu™, , Electronic Expansion Valve (EXV)									
Minimum capacity	%	15	15	15	15	15	15	15	15	15	15
<b>Air heat exchanger</b>											
Aluminum micro-channel coils (MCHE)											
<b>Fans</b>											
FLYING-BIRD 6, axial fan with rotating impeller											
<b>Standard unit</b>											
Quantity		6	6	6	8	8	8	11	12	12	12
Maximum total air flow	l/s	28920	28920	28920	38560	38560	38560	53020	57840	57840	57840
Maximum rotation speed	r/s	15,7	15,7	15,7	15,7	15,7	15,7	15,7	15,7	15,7	15,7
<b>Unit + option 15LS</b>											
Maximum total air flow	l/s	23580	23580	23580	31440	31440	31440	43230	47160	47160	47160
Maximum rotation speed	r/s	11,7	11,7	11,7	11,7	11,7	11,7	11,7	11,7	11,7	11,7
<b>Water heat exchanger</b>											
Flooded multi-tube type											
Water volume	l	58	61	61	66	70	77	79	94	98	119
Max. water-side operating pressure without hydraulic module	kPa	1000	1000	1000	1000	1000	1000	1000	1000	1000	1000
<b>Hydraulic module (option)</b>											
Pump, Victaulic screen filter, relief valve, water and air drain valve, pressure sensors, expansion tank (option)											
Pump		Centrifugal pump, monocell, 48,3r/s, low or high pressure (as required), single or dual (as required)									
Expansion vessel volume	l	50	50	50	50						
Max. water-side operating pressure with hydraulic module	kPa	400	400	400	400						
<b>Water connections without or with hydraulic module</b>											
Victaulic® type											
<b>Standard &amp; option 8, without option 116</b>											
Nominal diameter	in	5	5	5	5	5	5	5	6	6	6
Actual outside diameter	mm	141,3	141,3	141,3	141,3	141,3	141,3	141,3	168,3	168,3	168,3
<b>Options 5, 6 et 100A</b>											
Nominal diameter	in	4	4	4	4	4	4	5	5	5	5
Actual outside diameter	mm	114,3	114,3	114,3	114,3	114,3	114,3	141,3	141,3	141,3	141,3
<b>Options 116</b>											
Nominal diameter	in	4	4	4	4	-	-	-	-	-	-
Actual outside diameter	mm	114,3	114,3	114,3	114,3	-	-	-	-	-	-
<b>Casing paint</b>											
Colour code RAL 7035											

(3) Options : 15 = Low noise, 15LS = Very Low noise, 118a = Dx freecooling option, 50= heat recovery.

(4) Values are guidelines only. Refer to the unit name plate.

## PHYSICAL DATA, SIZES 30XBE-850 TO 1700

30XBE			850	900	1000	1100	1200	1300	1400	1500	1700	
<b>Cooling</b>												
<b>Standard unit</b>	CA1	Nominal capacity	kW	824,7	898,8	982,6	1143,0	1262,4	1329,6	1440,7	1511,5	1683,9
		Full load performances*	kW/kW	3,08	3,12	3,17	3,22	3,19	3,16	3,05	3,07	3,21
<b>Unit with option 15LS (+)</b>	CA1	Nominal capacity	kW	795	878	969	1113	1226	1290	1392	1464	1639
		Full load performances*	kW/kW	2,89	2,99	3,03	3,11	3,05	2,98	2,82	2,89	3,10
<b>Standard unit</b>	Seasonal energy efficiency **	SEER <sup>12/7°C</sup> Comfort low temp.	kWh/kWh	<b>4,56</b>	<b>4,56</b>	<b>4,60</b>	<b>4,58</b>	<b>4,61</b>	<b>4,55</b>	<b>4,55</b>	<b>4,55</b>	<b>4,56</b>
		η <sub>s cool</sub> <sup>12/7°C</sup>	%	<b>179</b>	<b>179</b>	<b>181</b>	<b>180</b>	<b>181</b>	<b>179</b>	<b>179</b>	<b>179</b>	<b>179</b>
<b>Unit with Option 5</b>	Seasonal energy efficiency **	SEPR <sup>12/7°C</sup> Process high temp.	kWh/kWh	<b>5,55</b>	<b>5,54</b>	<b>5,83</b>	<b>5,76</b>	<b>5,71</b>	<b>5,68</b>	<b>5,56</b>	<b>5,44</b>	<b>5,83</b>
		SEPR <sup>-2/-8°C</sup> Process medium temp.***	kWh/kWh	<b>3,53</b>	<b>3,44</b>	<b>3,55</b>	<b>3,52</b>	<b>3,47</b>	<b>3,6</b>	<b>3,63</b>	<b>3,18</b>	<b>3,73</b>
<b>Unit with Option 299</b>	Seasonal energy efficiency **	SEER <sup>12/7°C</sup> Comfort low temp.	kWh/kWh	NA	NA	NA	NA	NA	NA	NA	NA	NA
		η <sub>s cool</sub> <sup>12/7°C</sup>	%	NA	NA	NA	NA	NA	NA	NA	NA	NA
<b>Unit with option 6</b>	Seasonal energy efficiency **	SEPR <sup>12/7°C</sup> Process high temp.	kWh/kWh	NA	NA	NA	NA	NA	NA	NA	NA	NA
		SEPR <sup>-2/-8°C</sup> Process medium temp.***	kWh/kWh	<b>3,47</b>	<b>3,39</b>	<b>3,47</b>	<b>3,29</b>	<b>2,63</b>	<b>3,45</b>	<b>3,53</b>	<b>3,20</b>	<b>3,48</b>
<b>Unit with 15LS (+)</b>	Seasonal energy efficiency **	SEER <sup>12/7°C</sup> Comfort low temp.	kWh/kWh	<b>4,56</b>	<b>4,57</b>	<b>4,56</b>	<b>4,60</b>	<b>4,62</b>	<b>4,59</b>	4,56	<b>4,55</b>	4,58
		η <sub>s cool</sub> <sup>12/7°C</sup>	%	<b>179</b>	<b>180</b>	<b>179</b>	<b>181</b>	<b>182</b>	<b>181</b>	179	<b>179</b>	180
<b>Unit with option 5 &amp; 15LS (+)</b>	Seasonal energy efficiency **	SEPR <sup>12/7°C</sup> Process high temp.	kWh/kWh	<b>5,80</b>	<b>5,76</b>	<b>5,88</b>	<b>5,90</b>	<b>5,81</b>	<b>5,71</b>	<b>5,68</b>	<b>5,52</b>	<b>5,81</b>
		SEPR <sup>-2/-8°C</sup> Process medium temp.***	kWh/kWh	<b>3,66</b>	<b>3,55</b>	<b>3,78</b>	<b>3,61</b>	<b>3,31</b>	<b>3,22</b>	<b>3,27</b>	<b>3,28</b>	<b>3,80</b>
<b>Unit with Option 299 &amp; 15LS (+)</b>	Seasonal energy efficiency **	SEER <sup>12/7°C</sup> Comfort low temp.	kWh/kWh	NA	NA	NA	NA	NA	NA	NA	NA	NA
		η <sub>s cool</sub> <sup>12/7°C</sup>	%	NA	NA	NA	NA	NA	NA	NA	NA	NA
<b>Unit with option 6 &amp; 15LS (+)</b>	Seasonal energy efficiency **	SEPR <sup>12/7°C</sup> Process high temp.	kWh/kWh	NA	NA	NA	NA	NA	NA	NA	NA	NA
		SEPR <sup>-2/-8°C</sup> Process medium temp.***	kWh/kWh	<b>3,59</b>	<b>3,47</b>	<b>3,7</b>	<b>3,58</b>	<b>3,44</b>	<b>3,67</b>	<b>3,67</b>	<b>3,45</b>	<b>3,77</b>
<b>Sound levels</b>												
<b>Standard unit</b>												
Sound power <sup>(1)</sup>		dB(A)	101	104	102	103	102	104	104	104	104	104
Sound pressure at 10 m <sup>(2)</sup>		dB(A)	68	71	69	70	69	71	71	71	71	70
<b>Unit + option 15<sup>(3)</sup></b>												
Sound power <sup>(1)</sup>		dB(A)	97	99	98	98	98	100	99	99	99	100
Sound pressure at 10 m <sup>(2)</sup>		dB(A)	64	66	65	65	65	67	66	66	66	66
<b>Unit + option 15LS<sup>(3)</sup></b>												
Sound power <sup>(1)</sup>		dB(A)	94	95	94	94	94	99	95	96	96	96
Sound pressure at 10 m <sup>(2)</sup>		dB(A)	61	62	61	61	61	66	62	63	62	62
<b>Unit + option 15LS+<sup>(3)</sup></b>												
Sound power <sup>(1)</sup>		dB(A)	91	93	92	93	93	97	94	95	93	93
Sound pressure at 10 m <sup>(2)</sup>		dB(A)	58	60	59	60	60	64	61	62	59	59

\* In accordance with standard EN14511-3:2022.  
 \*\* In accordance with standard EN14825:2022, average climate  
 \*\*\* With EG 30%  
 + SEER calculated with the option 119  
 CA1 Cooling mode conditions: Evaporator water entering/leaving temperature 12°C/7°C, outside air temperature 35°C, evaporator fouling factor 0 m<sup>2</sup>.K/W  
 η<sub>s cool</sub><sup>12/7°C</sup> & SEER <sup>12/7°C</sup> **Bold values compliant to Ecodesign regulation: (EU) No 2016/2281 for Comfort application**  
 SEPR <sup>-2/-8°C</sup> **Bold values compliant to Ecodesign regulation: (EU) No 2015/1095 for Process application**  
 NA Non Authorized for the specific application for CEE market  
 - Not applicable  
 (1) in dB ref=10<sup>-12</sup> W, 'A' weighted. Declared dual-number noise emission values in accordance with ISO 4871 with an associated uncertainty of +/-3dB(A). Measured in accordance with ISO 9614-1 and certified by Eurovent.  
 (2) In dB ref 20μPa, 'A' weighted. Declared dual-number noise emission values in accordance with ISO 4871 with an associated uncertainty of +/-3dB(A). For information, calculated from the sound power Lw(A).  
 (3) Options : 15 = Low noise, 15LS = Very Low noise, 118a = DX freecooling option, 50= heat recovery.



Eurovent certified values



## PHYSICAL DATA, SIZES 30XBE-850 TO 1700

30XBE		850	900	1000	1100	1200	1300	1400	1500	1700
<b>Dimensions</b>										
<b>Standard unit</b>										
Length	mm	7186	8380	9574	11962	11962	11962	11962	13157	8380/ 8380
Width	mm	2253	2253	2253	2253	2253	2253	2253	2253	2253
Height	mm	2322	2322	2322	2322	2322	2322	2322	2322	2322
<b>Operating weight<sup>(4)</sup></b>										
Standard unit	kg	5563	6169	6665	7928	8069	8660	8735	9072	5935/ 5935
Unit + option 15 <sup>(3)</sup>	kg	5894	6499	6996	8302	8443	9034	9109	9446	6266/ 6266
Unit + option 118 <sup>(3)</sup>	kg	6050	6388	6862	-	-	-	-	-	-
Unit + option 50 <sup>(3)</sup>	kg	6726	7130	7619	-	-	-	-	-	-
<b>Compressors</b>										
06T semi-hermetic screw compressor, 50 r/s										
Circuit A		1	1	1	1	1	1	1	1	1
Circuit B		1	1	1	1	1	1	1	1	1
Circuit C										1
Circuit D										1
No. of control stages										
<b>Refrigerant<sup>(4)</sup></b>										
R134a										
Circuit A	kg	69	72	79	82	84	115	121	124	75
	teqCO <sub>2</sub>	98,7	103,0	113,0	117,3	120,1	164,5	173,0	177,3	107,3
Circuit B	kg	67	74	83	118	130	121	127	130	67
	teqCO <sub>2</sub>	95,8	105,8	118,7	168,7	185,9	173,0	181,6	185,9	95,8
Circuit C	kg									75
	teqCO <sub>2</sub>									107,3
Circuit D	kg									67
	teqCO <sub>2</sub>									95,8
<b>Oil</b>										
Circuit A	l	27,6	27,6	27,6	27,6	27,6	36,0	36,0	36,0	27,6
Circuit B	l	23,5	27,6	27,6	36,0	36,0	36,0	36,0	36,0	23,5
Circuit C	l									27,6
Circuit D	l									23,5
<b>Capacity control</b>										
SmartVu™, Electronic Expansion Valve (EXV)										
Minimum capacity	%	15	15	15	15	15	15	15	15	8
<b>Air heat exchanger</b>										
Aluminum micro-channel coils (MCHE)										
<b>Fans</b>										
FLYING-BIRD 6, axial fan with rotating impeller										
<b>Standard unit</b>										
Quantity		12	14	16	19	20	20	20	22	28
Maximum total air flow	l/s	57840	67480	77120	91580	96400	96400	96400	106040	134960
Maximum rotation speed	r/s	15,7	15,7	15,7	15,7	15,7	15,7	15,7	15,7	15,7
<b>Unit + option 15LS</b>										
Maximum total air flow	l/s	47160	55020	62880	78600	78600	78600	78600	86460	110040
Maximum rotation speed	r/s	11,7	11,7	11,7	11,7	11,7	11,7	11,7	11,7	11,7
<b>Water heat exchanger</b>										
Flooded multi-tube type										
Water volume	l	119	130	140	164	174	180	189	189	240
Max. water-side operating pressure without hydraulic module	kPa	1000	1000	1000	1000	1000	1000	1000	1000	1000
<b>Water connections without or with hydraulic module</b>										
Victaulic® type										
<b>Standard &amp; option 8</b>										
Nominal diameter	in	6	6	8	6	6	6	6	6	6
Actual outside diameter	mm	168,3	168,3	219,1	168,3	168,3	168,3	168,3	168,3	168,3
<b>Options 5, 6 et 100A</b>										
Nominal diameter	in	5	5	6	6	6	6	6	6	6/6
Actual outside diameter	mm	141,3	141,3	168,3	168,3	168,3	168,3	168,3	168,3	168,3/ 168,3
<b>Casing paint</b>										
Colour code RAL 7035										

(3) Options : 15 = Low noise, 15LS = Very Low noise, 118a = Dx freecooling option, 50= heat recovery.

(4) Values are guidelines only. Refer to the unit name plate.

## PHYSICAL DATA, SIZES 30XBP-250 TO 800

30XBP		250	300	350	400	450	500	600	700	750	800			
<b>Cooling</b>														
<b>Standard unit</b>		Nominal capacity	kW		277	301	323	392	445	500	623	677	730	782
Full load performances*	CA1	EER	kW/kW		3,21	3,18	3,14	3,23	3,16	3,23	3,27	3,34	3,14	3,13
<b>Unit with Option 15LS</b>		Nominal capacity	kW		271	293	313	384	432	486	607	659	709	757
Full load performances*	CA1	EER	kW/kW		3,17	3,11	3,03	3,20	3,05	3,13	3,16	3,23	2,99	2,95
<b>Standard unit</b>		<b>SEER<sub>12/7°C</sub> Comfort low temp.</b>	<b>kWh/kWh</b>		<b>4,66</b>	<b>4,64</b>	<b>4,55</b>	<b>4,50</b>	<b>4,62</b>	<b>4,67</b>	<b>4,66</b>	<b>4,77</b>	<b>4,61</b>	<b>4,58</b>
Seasonal energy efficiency **		<b>η<sub>s</sub> cool<sub>12/7°C</sub></b>	<b>%</b>		<b>183</b>	<b>183</b>	<b>179</b>	<b>177</b>	<b>182</b>	<b>184</b>	<b>183</b>	<b>188</b>	<b>181</b>	<b>180</b>
		<b>SEPR<sub>12/7°C</sub> Process high temp.</b>	<b>kWh/kWh</b>		<b>6,12</b>	<b>6,16</b>	<b>6,11</b>	<b>6,06</b>	<b>6,01</b>	<b>6,13</b>		<b>6,18</b>	<b>5,81</b>	<b>5,69</b>
<b>Unit with option 5</b>		<b>SEPR<sub>-2/-8°C</sub> Process medium temp.***</b>	<b>kWh/kWh</b>		<b>2,86</b>	<b>3,26</b>	<b>3,39</b>	<b>2,97</b>	<b>3,67</b>	<b>3,80</b>	<b>3,84</b>	<b>4,02</b>	<b>3,61</b>	<b>3,63</b>
Seasonal energy efficiency **		<b>SEER<sub>12/7°C</sub> Comfort low temp.</b>	<b>kWh/kWh</b>		<b>4,59</b>	<b>4,57</b>	<b>4,52</b>	<b>4,61</b>	NA	NA	NA	NA	NA	NA
Seasonal energy efficiency **		<b>η<sub>s</sub> cool<sub>12/7°C</sub></b>	<b>%</b>		<b>180</b>	<b>180</b>	<b>178</b>	<b>181</b>	NA	NA	NA	NA	NA	NA
		<b>SEPR<sub>12/7°C</sub> Process high temp.</b>	<b>kWh/kWh</b>		<b>6,13</b>	<b>6,18</b>	<b>6,15</b>	<b>6,10</b>	NA	NA	NA	NA	NA	NA
<b>Unit with option 6</b>		<b>SEPR<sub>-2/-8°C</sub> Process medium temp.***</b>	<b>kWh/kWh</b>		<b>3,51</b>	<b>3,72</b>	<b>3,78</b>	<b>3,64</b>	<b>3,62</b>	<b>3,72</b>	<b>3,68</b>	<b>3,96</b>	<b>3,55</b>	<b>3,61</b>
Seasonal energy efficiency **		<b>SEER<sub>12/7°C</sub> Comfort low temp.</b>	<b>kWh/kWh</b>		<b>4,67</b>	<b>4,67</b>	<b>4,56</b>	<b>4,49</b>	<b>4,59</b>	<b>4,64</b>	<b>4,65</b>	<b>4,78</b>	<b>4,60</b>	<b>4,57</b>
Seasonal energy efficiency **		<b>η<sub>s</sub> cool<sub>12/7°C</sub></b>	<b>%</b>		<b>184</b>	<b>184</b>	<b>179</b>	<b>176</b>	<b>181</b>	<b>183</b>	<b>183</b>	<b>188</b>	<b>181</b>	<b>180</b>
		<b>SEPR<sub>12/7°C</sub> Process high temp.</b>	<b>kWh/kWh</b>		<b>6,09</b>	<b>6,18</b>	<b>6,08</b>	<b>5,88</b>	<b>5,90</b>	<b>6,11</b>	<b>6,07</b>	<b>6,23</b>	<b>5,85</b>	<b>5,85</b>
<b>Unit with option 5 &amp; 15LS(+)</b>		<b>SEPR<sub>-2/-8°C</sub> Process medium temp.***</b>	<b>kWh/kWh</b>		<b>2,85</b>	<b>3,25</b>	<b>3,42</b>	<b>2,94</b>	<b>3,64</b>	<b>3,7</b>	<b>3,93</b>	<b>3,97</b>	<b>3,64</b>	<b>3,68</b>
Seasonal energy efficiency **		<b>SEER<sub>12/7°C</sub> Comfort low temp.</b>	<b>kWh/kWh</b>		<b>4,59</b>	<b>4,59</b>	<b>4,51</b>	<b>4,58</b>	NA	NA	NA	NA	NA	NA
Seasonal energy efficiency **		<b>η<sub>s</sub> cool<sub>12/7°C</sub></b>	<b>%</b>		<b>181</b>	<b>181</b>	<b>177</b>	<b>180</b>	NA	NA	NA	NA	NA	NA
		<b>SEPR<sub>12/7°C</sub> Process high temp.</b>	<b>kWh/kWh</b>		<b>6,11</b>	<b>6,20</b>	<b>6,11</b>	<b>5,91</b>	NA	NA	NA	NA	NA	NA
<b>Unit with option 6 &amp; 15LS(+)</b>		<b>SEPR<sub>-2/-8°C</sub> Process medium temp.***</b>	<b>kWh/kWh</b>		<b>3,47</b>	<b>3,74</b>	<b>3,89</b>	<b>3,52</b>	<b>3,75</b>	<b>3,79</b>	<b>3,77</b>	<b>3,93</b>	<b>3,59</b>	<b>3,67</b>
Seasonal energy efficiency **														
<b>Sound levels</b>														
<b>Standard unit</b>														
Sound power <sup>(1)</sup>		dB(A)	99	99	99	99	101	99	101	99	103	103	103	103
Sound pressure at 10 m <sup>(2)</sup>		dB(A)	67	67	67	67	69	67	68	67	70	70	70	70
<b>Unit + option 15<sup>(3)</sup></b>														
Sound power <sup>(1)</sup>		dB(A)	93	93	94	95	95	95	97	96	97	98	98	98
Sound pressure at 10 m <sup>(2)</sup>		dB(A)	61	61	62	63	63	63	65	63	64	65	65	65
<b>Unit + option 15LS<sup>(3)</sup></b>														
Sound power <sup>(1)</sup>		dB(A)	87	87	87	90	91	91	93	92	94	94	94	94
Sound pressure at 10 m <sup>(2)</sup>		dB(A)	55	55	55	58	59	59	60	59	61	61	61	61
<b>Unit + option 15LS+<sup>(3)</sup></b>														
Sound power <sup>(1)</sup>		dB(A)	-	-	-	-	89	89	91	90	91	92	92	92
Sound pressure at 10 m <sup>(2)</sup>		dB(A)	-	-	-	-	56	56	57	56	58	58	58	58
<b>Dimensions</b>														
<b>Standard unit</b>														
Length		mm	3604	3604	3604	4798	4798	5992	7186	7186	7186	7186	7186	7186
Width		mm	2253	2253	2253	2253	2253	2253	2253	2253	2253	2253	2253	2253
Height		mm	2322	2322	2322	2322	2322	2322	2322	2322	2322	2322	2322	2322
<b>Operating weight<sup>(4)</sup></b>														
Standard unit		kg	2999	3030	3049	3629	3692	4023	4726	4860	5127	5439	5439	5439
Unit + option 15 <sup>(3)</sup>		kg	3267	3298	3317	3928	3991	4322	5057	5191	5458	5770	5770	5770

\* In accordance with standard EN14511-3:2022.  
 \*\* In accordance with standard EN14825:2022, average climate  
 \*\*\* With EG 30%  
 CA1 Cooling mode conditions: Evaporator water entering/leaving temperature 12°C/7°C, outside air temperature 35°C, evaporator fouling factor 0 m<sup>2</sup>.K/W  
 η<sub>s</sub> cool<sub>12/7°C</sub> & SEER<sub>12/7°C</sub> **Bold values compliant to Ecodesign regulation: (EU) No 2016/2281 for Comfort application**  
 SEPR<sub>-2/-8°C</sub> **Bold values compliant to Ecodesign regulation: (EU) No 2015/1095 for Process application**  
 NA Non Authorized for the specific application for CEE market  
 (1) in dB ref=10<sup>-12</sup> W, 'A' weighted. Declared dual-number noise emission values in accordance with ISO 4871 with an associated uncertainty of +/-3dB(A). Measured in accordance with ISO 9614-1 and certified by Eurovent.  
 (2) In dB ref20μPa, 'A' weighted. Declared dual-number noise emission values in accordance with ISO 4871 with an associated uncertainty of +/-3dB(A). For information, calculated from the sound power Lw(A).  
 (3) Options : 15 = Low noise, 15LS = Very Low noise, 118a = DX freecooling option, 50= heat recovery.  
 (4) Values are guidelines only. Refer to the unit name plate.



Eurovent certified values

## PHYSICAL DATA, SIZES 30XBP-250 TO 800

30XBP		250	300	350	400	450	500	600	700	750	800
<b>Compressors</b>		06T semi-hermetic screw compressor, 50 r/s									
Circuit A		1	1	1	1	1	1	1	1	1	1
Circuit B		1	1	1	1	1	1	1	1	1	1
No. of control stages											
<b>Refrigerant<sup>(4)</sup></b>		R134a									
Circuit A	kg	39	37	37	52	53	59	60	61	69	69
	teqCO <sub>2</sub>	55,8	52,9	52,9	74,4	75,8	83,7	85,8	87,2	98,0	98,7
Circuit B	kg	40	38	39	40	40	36	61	64	61	67
	teqCO <sub>2</sub>	57,2	54,3	55,8	57,2	57,2	51,5	87,2	91,5	86,5	95,8
<b>Oil</b>											
Circuit A	l	20,8	20,8	20,8	23,5	23,5	23,5	23,5	23,5	27,6	27,6
Circuit B	l	20,8	20,8	20,8	20,8	20,8	20,8	23,5	23,5	23,5	23,5
<b>Capacity control</b>		SmartVu™, , Electronic Expansion Valve (EXV)									
Minimum capacity	%	15	15	15	15	15	15	15	15	15	15
<b>Air heat exchanger</b>		Aluminum micro-channel coils (MCHE)									
<b>Fans</b>		FLYING-BIRD 6, axial fan with rotating impeller									
<b>Standard unit</b>											
Quantity		6	6	6	8	8	9	11	12	12	12
Maximum total air flow	l/s	28920	28920	28920	38560	38560	43380	53020	57840	57840	57840
Maximum rotation speed	r/s	15,7	15,7	15,7	15,7	15,7	15,7	15,7	15,7	15,7	15,7
<b>Unit + option 15LS</b>											
Maximum total air flow	l/s	23580	23580	23580	31440	31440	35370	43230	47160	47160	47160
Maximum rotation speed	r/s	11,7	11,7	11,7	11,7	11,7	11,7	11,7	11,7	11,7	11,7
<b>Water heat exchanger</b>		Flooded multi-tube type									
Water volume	l	58	61	61	66	70	77	79	94	98	119
Max. water-side operating pressure without hydraulic module	kPa	1000	1000	1000	1000	1000	1000	1000	1000	1000	1000
<b>Hydraulic module (option)</b>		Pump, Victaulic screen filter, relief valve, water and air drain valve, pressure sensors, expansion tank (option)									
Pump		Centrifugal pump, monocell, 48,3r/s, low or high pressure (as required), single or dual (as required)									
Expansion vessel volume	l	50	50	50	50						
Max. water-side operating pressure with hydraulic module	kPa	400	400	400	400						
<b>Water connections without or with hydraulic module</b>		Victaulic® type									
<b>Standard &amp; option 8, without option 116</b>											
Nominal diameter	in	5	5	5	5	5	5	5	6	6	6
Actual outside diameter	mm	141,3	141,3	141,3	141,3	141,3	141,3	141,3	168,3	168,3	168,3
<b>Options 5, 6 et 100A</b>											
Nominal diameter	in	4	4	4	4	4	4	5	5	5	5
Actual outside diameter	mm	114,3	114,3	114,3	114,3	114,3	114,3	141,3	141,3	141,3	141,3
<b>Options 116</b>											
Nominal diameter	in	4	4	4	4	-	-	-	-	-	-
Actual outside diameter	mm	114,3	114,3	114,3	114,3	-	-	-	-	-	-
<b>Casing paint</b>		Colour code RAL 7035									

(4) Values are guidelines only. Refer to the unit name plate.

## PHYSICAL DATA, SIZES 30XBP-850 TO 1500

30XBP			850	900	1000	1100	1200	1300	1400	1500	
<b>Cooling</b>											
<b>Standard unit</b>	CA1	Nominal capacity	kW	837	899	982	1143	1262	1330	1441	1512
Full load performances*		EER	kW/kW	3,27	3,15	3,21	3,28	3,24	3,20	3,08	3,11
<b>Unit with Option 15LS</b>	CA1	Nominal capacity	kW	813	872	969	1113	1227	1290	1391	1466
Full load performances *		EER	kW/kW	3,13	2,98	3,06	3,16	3,06	3,01	2,84	2,91
<b>Standard unit</b>		<b>SEER <sub>12/17°C</sub> Comfort low temp.</b>	<b>kWh/kWh</b>	<b>4,68</b>	<b>4,61</b>	<b>4,69</b>	<b>4,70</b>	<b>4,72</b>	<b>4,62</b>	<b>4,63</b>	<b>4,62</b>
Seasonal energy efficiency **		<b>η<sub>s</sub> cool <sub>12/17°C</sub></b>	<b>%</b>	<b>184</b>	<b>181</b>	<b>185</b>	<b>185</b>	<b>186</b>	<b>182</b>	<b>182</b>	<b>182</b>
		<b>SEPR <sub>12/17°C</sub> Process high temp.</b>	<b>kWh/kWh</b>	<b>5,96</b>	<b>5,84</b>	<b>5,83</b>	<b>5,90</b>	<b>5,87</b>	<b>5,99</b>	<b>5,65</b>	<b>6,16</b>
<b>Unit with option 5</b>		<b>SEPR <sub>-2/-8°C</sub> Process medium temp.***</b>	<b>kWh/kWh</b>	<b>3,83</b>	<b>3,67</b>	<b>3,66</b>	<b>3,77</b>	<b>3,66</b>	<b>3,70</b>	<b>3,72</b>	<b>3,24</b>
Seasonal energy efficiency **		<b>SEER <sub>12/17°C</sub> Comfort low temp.</b>	<b>kWh/kWh</b>	NA	NA	NA	NA	NA	NA	NA	NA
		<b>η<sub>s</sub> cool <sub>12/17°C</sub></b>	<b>%</b>	NA	NA	NA	NA	NA	NA	NA	NA
		<b>SEPR <sub>12/17°C</sub> Process high temp.</b>	<b>kWh/kWh</b>	NA	NA	NA	NA	NA	NA	NA	NA
<b>Unit with option 6</b>		<b>SEPR <sub>-2/-8°C</sub> Process medium temp.***</b>	<b>kWh/kWh</b>	<b>3,75</b>	<b>3,64</b>	<b>3,58</b>	<b>3,45</b>	<b>3,73</b>	<b>3,59</b>	<b>3,69</b>	<b>3,42</b>
Seasonal energy efficiency **		<b>SEER <sub>12/17°C</sub> Comfort low temp.</b>	<b>kWh/kWh</b>	<b>4,66</b>	<b>4,58</b>	<b>4,67</b>	<b>4,68</b>	<b>4,70</b>	<b>4,57</b>	<b>4,56</b>	<b>4,56</b>
		<b>η<sub>s</sub> cool <sub>12/17°C</sub></b>	<b>%</b>	<b>183</b>	<b>180</b>	<b>184</b>	<b>184</b>	<b>185</b>	<b>180</b>	<b>179</b>	<b>179</b>
		<b>SEPR <sub>12/17°C</sub> Process high temp.</b>	<b>kWh/kWh</b>	<b>5,97</b>	<b>5,87</b>	<b>5,91</b>	<b>6,17</b>	<b>6,12</b>	<b>5,98</b>	<b>5,77</b>	<b>5,98</b>
<b>Unit with option 5 &amp; 15LS(+)</b>		<b>SEPR <sub>-2/-8°C</sub> Process medium temp.***</b>	<b>kWh/kWh</b>	<b>3,75</b>	<b>3,65</b>	<b>3,72</b>	<b>3,55</b>	<b>3,49</b>	<b>3,41</b>	<b>3,45</b>	<b>3,46</b>
Seasonal energy efficiency **		<b>SEER <sub>12/17°C</sub> Comfort low temp.</b>	<b>kWh/kWh</b>	NA	NA	NA	NA	NA	NA	NA	NA
		<b>η<sub>s</sub> cool <sub>12/17°C</sub></b>	<b>%</b>	NA	NA	NA	NA	NA	NA	NA	NA
		<b>SEPR <sub>12/17°C</sub> Process high temp.</b>	<b>kWh/kWh</b>	NA	NA	NA	NA	NA	NA	NA	NA
<b>Unit with Option 299 &amp; 15LS(+)</b>		<b>SEPR <sub>-2/-8°C</sub> Process medium temp.***</b>	<b>kWh/kWh</b>	<b>3,69</b>	<b>3,64</b>	<b>3,65</b>	<b>3,69</b>	<b>3,70</b>	<b>3,93</b>	<b>3,87</b>	<b>3,50</b>
Seasonal energy efficiency **											
<b>Sound levels</b>											
<b>Standard unit</b>											
Sound power <sup>(1)</sup>		dB(A)	101	104	102	103	102	104	104	104	104
Sound pressure at 10 m <sup>(2)</sup>		dB(A)	70	71	69	70	69	71	71	71	71
<b>Unit + option 15<sup>(3)</sup></b>											
Sound power <sup>(1)</sup>		dB(A)	97	99	98	98	98	100	99	99	99
Sound pressure at 10 m <sup>(2)</sup>		dB(A)	65	66	65	65	65	67	65	65	65
<b>Unit + option 15LS<sup>(3)</sup></b>											
Sound power <sup>(1)</sup>		dB(A)	94	95	94	94	94	99	95	96	96
Sound pressure at 10 m <sup>(2)</sup>		dB(A)	61	62	61	61	61	66	62	63	63
<b>Unit + option 15LS+<sup>(3)</sup></b>											
Sound power <sup>(1)</sup>		dB(A)	91	93	92	93	93	97	94	95	95
Sound pressure at 10 m <sup>(2)</sup>		dB(A)	58	60	59	60	60	66	61	62	62
<b>Dimensions</b>											
<b>Standard unit</b>											
Length		mm	8380	8380	9574	11962	11962	11962	11962	13157	13157
Width		mm	2253	2253	2253	2253	2253	2253	2253	2253	2253
Height		mm	2322	2322	2322	2322	2322	2322	2322	2322	2322
<b>Operating weight<sup>(4)</sup></b>											
Standard unit		kg	5795	6080	6561	7812	7949	8565	8640	8941	8941
Unit + option 15 <sup>(3)</sup>		kg	6126	6411	6892	8183	8320	8939	9014	9315	9315

\* In accordance with standard EN14511-3:2022.  
 \*\* In accordance with standard EN14825:2022, average climate  
 \*\*\* With EG 30%  
 CA1 Cooling mode conditions: Evaporator water entering/leaving temperature 12°C/7°C, outside air temperature 35°C, evaporator fouling factor 0 m<sup>2</sup>.K/W  
**η<sub>s</sub> cool<sub>12/17°C</sub> & SEER<sub>12/17°C</sub>** **Bold values compliant to Ecodesign regulation: (EU) No 2016/2281 for Comfort application**  
**SEPR<sub>-2/-8°C</sub>** **Bold values compliant to Ecodesign regulation: (EU) No 2015/1095 for Process application**  
 NA Non Authorized for the specific application for CEE market  
 (1) in dB ref=10<sup>-12</sup> W, 'A' weighted. Declared dual-number noise emission values in accordance with ISO 4871 with an associated uncertainty of +/-3dB(A). Measured in accordance with ISO 9614-1 and certified by Eurovent.  
 (2) In dB ref 20μPa, 'A' weighted. Declared dual-number noise emission values in accordance with ISO 4871 with an associated uncertainty of +/-3dB(A). For information, calculated from the sound power Lw(A).  
 (3) Options : 15 = Low noise, 15LS = Very Low noise, 118a = DX freecooling option, 50= heat recovery.  
 (4) Values are guidelines only. Refer to the unit name plate.



Eurovent certified values

## PHYSICAL DATA, SIZES 30XBP-850 TO 1700

30XBP		850	900	1000	1100	1200	1300	1400	1500
<b>Compressors</b>		06T semi-hermetic screw compressor, 50 r/s							
Circuit A		1	1	1	1	1	1	1	1
Circuit B		1	1	1	1	1	1	1	1
No. of control stages									
<b>Refrigerant<sup>(4)</sup></b>		R134a							
Circuit A	kg	75	72	79	82	84	115	121	124
	teqCO <sub>2</sub>	107,3	103,0	113,0	117,3	120,1	164,5	173,0	177,3
Circuit B	kg	67	74	83	118	130	121	127	130
	teqCO <sub>2</sub>	95,8	105,8	118,7	168,7	185,9	173,0	181,6	185,9
<b>Oil</b>									
Circuit A	l	27,6	27,6	27,6	27,6	27,6	36,0	36,0	36,0
Circuit B	l	23,5	27,6	27,6	36,0	36,0	36,0	36,0	36,0
<b>Capacity control</b>		SmartVu™, , Electronic Expansion Valve (EXV)							
Minimum capacity	%	15	15	15	15	15	15	15	15
<b>Air heat exchanger</b>		Aluminum micro-channel coils (MCHE)							
<b>Fans</b>		FLYING-BIRD 6, axial fan with rotating impeller							
<b>Standard unit</b>									
Quantity		14	14	16	19	20	20	20	22
Maximum total air flow	l/s	67480	67480	77120	91580	96400	96400	96400	106040
Maximum rotation speed	r/s	15,7	15,7	15,7	15,7	15,7	15,7	15,7	15,7
<b>Unit + option 15LS</b>									
Maximum total air flow	l/s	55020	55020	62880	78600	78600	78600	78600	86460
Maximum rotation speed	r/s	11,7	11,7	11,7	11,7	11,7	11,7	11,7	11,7
<b>Water heat exchanger</b>		Flooded multi-tube type							
Water volume	l	119	130	140	164	174	180	189	189
Max. water-side operating pressure without hydraulic module	kPa	1000	1000	1000	1000	1000	1000	1000	1000
<b>Hydraulic module (option)</b>		Pump, Victaulic screen filter, relief valve, water and air drain valve, pressure sensors, expansion tank (option)							
Pump		Centrifugal pump, monocell, 48,3r/s, low or high pressure (as required), single or dual (as required)							
Expansion vessel volume	l								
Max. water-side operating pressure with hydraulic module	kPa								
<b>Water connections without or with hydraulic module</b>		Victaulic® type							
<b>Standard &amp; option 8</b>									
Nominal diameter	in	6	6	8	6	6	6	6	6
Actual outside diameter	mm	168,3	168,3	219,1	168,3	168,3	168,3	168,3	168,3
<b>Options 5, 6 et 100A</b>									
Nominal diameter	in	5	5	6	6	6	6	6	6
Actual outside diameter	mm	141,3	141,3	168,3	168,3	168,3	168,3	168,3	168,3
<b>Casing paint</b>		Colour code RAL 7035							

(4) Values are guidelines only. Refer to the unit name plate.



## ELECTRICAL DATA, 30XB-250 TO 1000

30XB		250	300	350	400	450	500	600	700	750	800	850	900	1000
<b>Power circuit supply</b>														
Nominal voltage	V-ph-Hz	400-3-50												
Voltage range	V	360-440												
<b>Control circuit supply</b>														
24 V via internal transformer														
<b>Maximum operating input power<sup>(1)</sup> - 30XB</b>														
Standard unit	kW	127	137	148	173	193	212	259	279	310	328	359	377	442
Unit + option 15LS	kW	121	132	142	166	186	204	249	268	299	317	348	366	428
<b>Power factor at maximum power<sup>(1)</sup> - 30XB</b>														
<b>Standard unit</b>														
Displacement Power Factor (Cos Phi)		0,88	0,87	0,87	0,88	0,88	0,88	0,88	0,88	0,87	0,87	0,88	0,87	0,88
<b>Unit + option 15LS</b>														
Displacement Power Factor (Cos Phi)		0,88	0,87	0,87	0,88	0,88	0,88	0,88	0,88	0,87	0,87	0,88	0,87	0,88
<b>Nominal operating current draw<sup>(2)</sup> - 30XB</b>														
Standard unit	A	151	167	183	211	242	263	327	351	402	423	439	495	535
Unit + option 15LS	A	142	158	174	199	230	251	310	333	384	405	421	477	513
<b>Maximum operating current draw (Un)<sup>(1)</sup> - 30XB</b>														
Standard unit	A	209	227	245	285	318	348	426	459	514	544	590	629	729
Unit + option 15LS	A	200	218	236	273	306	336	409	441	496	526	572	611	707
<b>Maximum current (Un-10%)<sup>(1)</sup> - 30XB</b>														
Standard unit	A	221	240	259	301	336	368	450	485	544	576	625	667	773
Unit + option 15LS	A	212	231	250	289	324	356	433	467	526	558	607	649	751
<b>Nominal start-up current<sup>(3)</sup> - 30XB</b>														
Standard unit	A	246	246	262	379	480	480	539	564	738	759	759	835	835
Unit + option 15LS	A	241	241	257	374	475	475	531	555	730	751	751	826	844
Unit + option 25C	A	184	177	193	317	411	411	413	438	631	637	637	666	659
<b>Maximum start-up current(Un)<sup>(2)</sup> - 30XB</b>														
Standard unit	A	275	293	293	408	511	511	618	618	783	813	813	902	952
Unit + option 15LS	A	270	288	288	403	506	506	610	609	775	805	805	893	941
Unit + option 25C	A	213	224	224	346	442	442	492	492	676	691	691	733	756

(1) Values obtained at unit continuous maximum operating conditions (data given on the unit nameplate)

(2) Operating current of the smallest compressor(s) + fan current + locked rotor current or reduced start-up current of the largest compressor.

(3) Standardised EUROVENT conditions, water-cooled exchanger water inlet/outlet = 12°C/7°C, outdoor air temperature = 35°C.

**ELECTRICAL DATA, 30XB-1100 TO 1700**

30XB		1100	1200	1300	1400	1500	1700
<b>Power circuit supply</b>							
Nominal voltage	V-ph-Hz	400-3-50					
Voltage range	V	360-440					
<b>Control circuit supply</b>							
24 V via internal transformer							
<b>Maximum operating input power<sup>(1)</sup> - 30XB</b>							
<b>Standard unit</b>							
Circuit 1 <sup>(a)</sup>	kW	194	223	264	284	307	363
Circuit 2 <sup>(a)</sup>	kW	284	308	282	305	307	363
Option 081	kW	478	532	546	588	614	-
<b>Unit + option 15LS</b>							
Circuit 1 <sup>(a)</sup>	kW	187	216	255	274	297	351
Circuit 2 <sup>(a)</sup>	kW	275	298	273	296	297	351
Option 081	kW	461	514	528	570	594	-
<b>Power factor at maximum power<sup>(1)</sup> - 30XB</b>							
<b>Standard unit</b>							
Displacement Power Factor (Cos Phi)		0,89	0,89	0,89	0,89	0,89	0,90
<b>Unit + option 15LS</b>							
Displacement Power Factor (Cos Phi)		0,89	0,89	0,89	0,89	0,89	0,90
<b>Nominal operating current draw<sup>(2)</sup> - 30XB</b>							
<b>Standard unit</b>							
Circuit 1 <sup>(a)</sup>	A	251	267	334	347	382	439
Circuit 2 <sup>(a)</sup>	A	350	386	347	379	382	439
Option 081	A	601	652	681	726	764	-
<b>Unit + option 15LS</b>							
Circuit 1 <sup>(a)</sup>	A	239	255	319	332	366	417
Circuit 2 <sup>(a)</sup>	A	334	367	332	364	366	417
Option 081	A	572	621	650	695	731	-
<b>Maximum operating current draw (Un)<sup>(1)</sup> - 30XB</b>							
<b>Standard unit</b>							
Circuit 1 <sup>(a)</sup>	A	316	362	430	460	498	586
Circuit 2 <sup>(a)</sup>	A	463	500	460	495	498	586
Option 081	A	778	862	889	954	995	-
<b>Unit + option 15LS</b>							
Circuit 1 <sup>(a)</sup>	A	304	350	415	445	482	566
Circuit 2 <sup>(a)</sup>	A	447	483	445	480	482	566
Option 081	A	751	833	860	925	963	-

(1) Values obtained at unit continuous maximum operating conditions (data given on the unit nameplate)  
 (2) Operating current of the smallest compressor(s) + fan current + locked rotor current or reduced start-up current of the largest compressor.  
 (3) Standardised EUROVENT conditions, water-cooled exchanger water inlet/outlet = 12°C/7°C, outdoor air temperature = 35°C.  
 (a) When the machines are equipped with two power supplies, circuit 1 supplies the refrigerant circuit A and circuit 2 supplies the refrigerant circuit B or for units 30XB1550 to 1700 units: Circuit 1 supplies circuits A and B, circuit 2 supplies circuits C and D.

## ELECTRICAL DATA, 30XB-1100 TO 1700

30XB		1100	1200	1300	1400	1500	1700
<b>Maximum current (Un-10%)<sup>(1)</sup> - 30XB</b>							
<b>Standard unit</b>							
Circuit 1 <sup>(a)</sup>	A	335	384	466	498	529	621
Circuit 2 <sup>(a)</sup>	A	501	531	498	526	529	621
Option 081	A	835	915	963	1023	1057	-
<b>Unit + option 15LS</b>							
Circuit 1 <sup>(a)</sup>	A	323	372	451	483	513	601
Circuit 2 <sup>(a)</sup>	A	485	514	483	511	513	601
Option 081	A	808	886	934	994	1025	-
<b>Nominal start-up current<sup>(3)</sup> - 30XB</b>							
<b>Standard unit</b>							
Circuit 1 <sup>(a)</sup>	A	587	587	629	629	629	759
Circuit 2 <sup>(a)</sup>	A	629	629	629	629	629	759
Option 081	A	944	979	982	1014	1018	-
Option 081 & Opt 25c	A	687	702	729	744	744	-
<b>Unit + option 15LS</b>							
Circuit 1 <sup>(a)</sup>	A	587	587	629	629	629	751
Circuit 2 <sup>(a)</sup>	A	629	629	629	629	629	751
Option 081	A	927	961	966	998	1001	-
Option 081 & Opt 25c	A	671	684	714	729	727	-
<b>Maximum start-up current(Un)<sup>(2)</sup> - 30XB</b>							
<b>Standard unit</b>							
Circuit 1 <sup>(a)</sup>	A	587	587	629	629	629	813
Circuit 2 <sup>(a)</sup>	A	629	629	629	629	629	813
Option 081	A	1059	1097	1097	1132	1136	-
Option 081 & Opt 25c	A	802	820	844	862	862	-
<b>Unit + option 15LS</b>							
Circuit 1 <sup>(a)</sup>	A	587	587	629	629	629	805
Circuit 2 <sup>(a)</sup>	A	629	629	629	629	629	805
Option 081	A	1042	1079	1081	1116	1119	-
Option 081 & Opt 25c	A	786	802	829	847	845	-

(1) Values obtained at unit continuous maximum operating conditions (data given on the unit nameplate)

(2) Operating current of the smallest compressor(s) + fan current + locked rotor current or reduced start-up current of the largest compressor.

(3) Standardised EUROVENT conditions, water-cooled exchanger water inlet/outlet = 12°C/7°C, outdoor air temperature = 35°C.

(a) When the machines are equipped with two power supplies, circuit 1 supplies the refrigerant circuit A and circuit 2 supplies the refrigerant circuit B or for units 30XB1550 to 1700 units: Circuit 1 supplies circuits A and B, circuit 2 supplies circuits C and D.

## ELECTRICAL DATA, 30XBP-250 TO 1000

30XBP		250	300	350	400	450	500	600	700	750	800	850	900	1000
<b>Power circuit supply</b>														
Nominal voltage	V-ph-Hz	400-3-50												
Voltage range	V	360-440												
<b>Control circuit supply</b>		24 V via internal transformer												
<b>Maximum operating input power<sup>(1)</sup> - 30XBP</b>														
Standard unit	kW	126	137	147	172	192	210	257	278	308	327	357	375	440
Unit + option 15LS	kW	124	135	145	170	189	208	254	274	304	323	353	371	434
<b>Power factor at maximum power<sup>(1)</sup> - 30XBP</b>														
<b>Standard unit</b>														
Displacement Power Factor (Cos Phi)		0,90	0,89	0,89	0,90	0,89	0,89	0,90	0,90	0,89	0,89	0,89	0,88	0,89
<b>Unit + option 15LS</b>														
Displacement Power Factor (Cos Phi)		0,90	0,89	0,89	0,90	0,89	0,89	0,90	0,90	0,89	0,89	0,89	0,88	0,89
<b>Nominal operating current draw<sup>(2)</sup> - 30XBP</b>														
Standard unit	A	145	161	177	203	234	255	315	339	390	411	427	483	521
Unit + option 15LS	A	142	158	174	199	230	251	310	333	384	405	420	476	512
<b>Maximum operating current draw (Un)<sup>(1)</sup> - 30XBP</b>														
Standard unit	A	203	221	239	277	310	340	414	447	502	532	578	617	715
Unit + option 15LS	A	200	218	236	273	306	336	409	441	496	526	571	610	706
<b>Maximum current (Un-10%)<sup>(1)</sup> - 30XBP</b>														
Standard unit	A	215	234	253	293	328	360	438	473	532	564	613	655	759
Unit + option 15LS	A	212	231	250	289	324	356	433	467	526	558	606	648	750
<b>Nominal start-up current<sup>(3)</sup> - 30XBP</b>														
Standard unit	A	243	243	259	376	477	477	534	558	733	754	754	829	848
Unit + option 15LS	A	241	241	257	374	475	475	531	555	730	751	751	826	844
Unit + option 25C	A	181	174	190	314	408	408	408	432	626	632	632	660	652
<b>Maximum start-up current(Un)<sup>(2)</sup> - 30XBP</b>														
Standard unit	A	272	290	290	405	508	508	613	612	778	808	808	896	945
Unit + option 15LS	A	270	288	288	403	506	506	610	609	775	805	805	893	941
Unit + option 25C	A	210	221	221	343	439	439	487	486	671	686	686	727	749

- (1) Values obtained at unit continuous maximum operating conditions (data given on the unit nameplate)
- (2) Operating current of the smallest compressor(s) + fan current + locked rotor current or reduced start-up current of the largest compressor.
- (3) Standardised EUROVENT conditions, water-cooled exchanger water inlet/outlet = 12°C/7°C, outdoor air temperature = 35°C.

## ELECTRICAL DATA, 30XBP-1100 TO 1500

30XBP		1100	1200	1300	1400	1500
<b>Power circuit supply</b>						
Nominal voltage	V-ph-Hz	400-3-50				
Voltage range	V	360-440				
<b>Control circuit supply</b>		24 V via internal transformer				
<b>Maximum operating input power<sup>(1)</sup> - 30XBP</b>						
<b>Standard unit</b>						
Circuit 1 <sup>(a)</sup>	kW	191	220	262	282	304
Circuit 2 <sup>(a)</sup>	kW	279	304	280	303	304
Option 081	kW	469	525	542	584	609
<b>Unit + option 15LS</b>						
Circuit 1 <sup>(a)</sup>	kW	188	217	258	278	301
Circuit 2 <sup>(a)</sup>	kW	276	301	277	300	301
Option 081	kW	463	518	535	578	602
<b>Power factor at maximum power<sup>(1)</sup> - 30XBP</b>						
<b>Standard unit</b>						
Displacement Power Factor (Cos Phi)		0,88	0,89	0,88	0,89	0,89
<b>Unit + option 15LS</b>						
Displacement Power Factor (Cos Phi)		0,88	0,89	0,88	0,89	0,89

- (1) Values obtained at unit continuous maximum operating conditions (data given on the unit nameplate)
- (a) When the machines are equipped with two power supplies, circuit 1 supplies the refrigerant circuit A and circuit 2 supplies the refrigerant circuit B or for units 30XBP1550 to 1700 units: Circuit 1 supplies circuits A and B, circuit 2 supplies circuits C and D.

## ELECTRICAL DATA, 30XBP-1100 TO 1500

30XBP		1100	1200	1300	1400	1500
<b>Nominal operating current draw<sup>(2)</sup> - 30XBP</b>						
<b>Standard unit</b>						
Circuit 1 <sup>(a)</sup>	A	245	261	330	343	377
Circuit 2 <sup>(a)</sup>	A	340	377	343	375	377
Option 081	A	584	638	672	717	754
<b>Unit + option 15LS</b>						
Circuit 1 <sup>(a)</sup>	A	240	256	324	337	372
Circuit 2 <sup>(a)</sup>	A	334	371	337	369	372
Option 081	A	574	627	661	706	743
<b>Maximum operating current draw (Un)<sup>(1)</sup> - 30XBP</b>						
<b>Standard unit</b>						
Circuit 1 <sup>(a)</sup>	A	312	358	428	458	495
Circuit 2 <sup>(a)</sup>	A	455	495	458	493	495
Option 081	A	766	853	885	950	990
<b>Unit + option 15LS</b>						
Circuit 1 <sup>(a)</sup>	A	307	353	422	452	490
Circuit 2 <sup>(a)</sup>	A	450	490	452	487	490
Option 081	A	756	842	874	939	979
<b>Maximum current (Un-10%)<sup>(1)</sup> - 30XBP</b>						
<b>Standard unit</b>						
Circuit 1 <sup>(a)</sup>	A	331	380	464	496	526
Circuit 2 <sup>(a)</sup>	A	493	526	496	524	526
Option 081	A	823	906	959	1019	1052
<b>Unit + option 15LS</b>						
Circuit 1 <sup>(a)</sup>	A	326	375	458	490	521
Circuit 2 <sup>(a)</sup>	A	488	521	490	518	521
Option 081		813	895	948	1008	1041
<b>Nominal start-up current<sup>(3)</sup> - 30XBP</b>						
<b>Standard unit</b>						
Circuit 1 <sup>(a)</sup>	A	587	587	629	629	629
Circuit 2 <sup>(a)</sup>	A	629	629	629	629	629
Option 081	A	927	964	972	1004	1006
Option 081 & Opt 25c	A	678	691	719	734	733
<b>Unit + option 15LS</b>						
Circuit 1 <sup>(a)</sup>	A	587	587	629	629	629
Circuit 2 <sup>(a)</sup>	A	629	629	629	629	629
Option 081	A	922	959	966	998	1001
Option 081 & Opt 25c	A	674	685	714	729	727
<b>Maximum start-up current(Un)<sup>(2)</sup> - 30XBP</b>						
<b>Standard unit</b>						
Circuit 1 <sup>(a)</sup>	A	587	587	629	629	629
Circuit 2 <sup>(a)</sup>	A	629	629	629	629	629
Option 081	A	1042	1082	1087	1122	1124
Option 081 & Opt 25c	A	793	809	834	852	851
<b>Unit + option 15LS</b>						
Circuit 1 <sup>(a)</sup>	A	587	587	629	629	629
Circuit 2 <sup>(a)</sup>	A	629	629	629	629	629
Option 081	A	1037	1077	1081	1116	1119
Option 081 & Opt 25c	A	789	803	829	847	845

(1) Values obtained at unit continuous maximum operating conditions (data given on the unit nameplate)

(2) Operating current of the smallest compressor(s) + fan current + locked rotor current or reduced start-up current of the largest compressor.

(3) Standardised EUROVENT conditions, water-cooled exchanger water inlet/outlet = 12°C/7°C, outdoor air temperature = 35°C.

(a) When the machines are equipped with two power supplies, circuit 1 supplies the refrigerant circuit A and circuit 2 supplies the refrigerant circuit B or for units 30XBP1550 to 1700 units: Circuit 1 supplies circuits A and B, circuit 2 supplies circuits C and D.





**ELECTRICAL DATA, 30XB WITH OPTION CU/AL HEAT EXCHANGER**

30XB with option 254 or 255	250	300	350	400	450	500	600	700	750	800	850	900	1000	
<b>Power circuit supply</b>														
Nominal voltage	V-ph-Hz			400-3-50										
Voltage range	V			360-440										
<b>Control circuit supply</b>														
24 V via internal transformer														
<b>Maximum operating input power<sup>(1)</sup> - 30XB</b>														
Standard unit	kW	127	137	150	173	193	214	259	279	312	331	363	384	446
Unit + option 15LS	kW	121	132	144	166	186	207	249	268	301	320	352	373	433
<b>Power factor at maximum power<sup>(1)</sup> - 30XB</b>														
<b>Standard unit</b>														
Displacement Power Factor (Cos Phi)		0,88	0,87	0,87	0,88	0,88	0,88	0,88	0,88	0,87	0,87	0,88	0,87	0,88
<b>Unit + option 15LS</b>														
Displacement Power Factor (Cos Phi)		0,88	0,87	0,87	0,88	0,88	0,88	0,88	0,88	0,87	0,87	0,88	0,87	0,88
<b>Nominal operating current draw<sup>(2)</sup> - 30XB</b>														
Standard unit	A	151	167	187	211	242	267	327	351	406	427	447	506	542
Unit + option 15LS	A	142	158	177	199	230	255	310	333	388	409	428	488	521
<b>Maximum operating current draw (Un)<sup>(1)</sup> - 30XB</b>														
Standard unit	A	209	227	249	285	318	352	426	459	518	548	598	640	736
Unit + option 15LS	A	200	218	239	273	306	340	409	441	500	530	579	622	715
<b>Maximum current (Un-10%)<sup>(1)</sup> - 30XB</b>														
Standard unit	A	221	240	263	301	336	372	450	485	548	580	633	678	780
Unit + option 15LS	A	212	231	253	289	324	360	433	467	530	562	614	660	759
<b>Nominal start-up current<sup>(3)</sup> - 30XB</b>														
Standard unit	A	246	246	262	379	480	480	539	564	738	759	759	835	835
Unit + option 15LS	A	241	241	257	374	475	475	531	555	730	751	751	826	844
Unit + option 25C	A	184	177	193	317	411	411	413	438	631	637	637	666	659
<b>Maximum start-up current(Un)<sup>(2)</sup> - 30XB</b>														
Standard unit	A	275	293	293	408	511	511	618	618	783	813	813	902	952
Unit + option 15LS	A	270	288	288	403	506	506	610	609	775	805	805	893	941
Unit + option 25C	A	213	224	224	346	442	442	492	492	676	691	691	733	756

(1) Values obtained at unit continuous maximum operating conditions (data given on the unit nameplate)  
 (2) Operating current of the smallest compressor(s) + fan current + locked rotor current or reduced start-up current of the largest compressor.  
 (3) Standardised EUROVENT conditions, water-cooled exchanger water inlet/outlet = 12°C/7°C, outdoor air temperature = 35°C.

- 30XB(E/P)&XBP 250 to 1000 units have a single power connection point; 30XB(E/P)&XBP 1100 to 1700 units have two connection points.
- The control box includes the following standard features:
  - One general disconnect switch per circuit
  - Starter and motor protection devices for each compressor, the fan(s) and the pump
  - Control devices

**IMPORTANT:**

- Generally the recommendations of IEC 60364 are accepted as compliance with the requirements of the installation regulations.
- Conformance with EN 60204 is the best means of ensuring compliance with the Machines Directive 1.5.1.

Annex B of EN 60204-1 describes the electrical characteristics used for the operation of the machines.

1. Environment\* . Environment as classified in EN 60364 (corresponds to IEC 60364):
  - Outdoor installation\*
  - Ambient temperature range: from -20°C to +55°C\*\*
  - altitude less than or equal to 2000 m (for hydronic module, see paragraph 4.7 in the IOM)
  - presence of hard solids, class AE3 (no significant dust present)\*
  - presence of corrosive and polluting substances, class AF1 (negligible)
  - Units shall not be located in places open to all persons, which can include children.
2. Compatibility for low-frequency conducted disturbances according to IEC61000-2-2 and to class 2 levels per IEC61000-2-4 standard:
  - Power supply frequency variation : +-2Hz
  - Phase imbalance : 2%
  - Total Voltage Harmonic Distortion (THDV) : 8%\*\*\*
3. The neutral (N) line must not be connected directly to the unit (if necessary use a transformer).

4. Overcurrent protection of the power supply conductors is not provided with the unit.
5. The factory-installed disconnect switch(es)/circuit breaker(s) is (are) of a type suitable for power interruption in accordance with EN 60947-3 (corresponds to IEC 60947-3).
6. The units are designed for simplified connection on TN(s) networks (IEC 60364). For IT networks provide a local earth and consult competent local organisations to complete the electrical installation. Units delivered with variable frequency drive(s) (options : 28, 17 & 30XBE range) are not compatible with IT network. 30XB units are designed to use for domestic / residential and industrial environments:

Machines that are not equipped with variable frequency drive(s) are in accordance with the codes :

- 61000-6-3: General standards - Standard emission for residential, commercial and light industry.
  - 61000-6-2: General standards - Immunity for industrial environments.
- Machines that are equipped with variable frequency drive(s) (options 28, 17 & 30XBE range) are in accordance with the codes
- 61000-6-4: Generic standards - Emission standard for industrial environments.
  - 61000-6-2: Generic standards - Immunity for industrial environments.

- Leakage currents: If protection by monitoring the leakage currents is necessary to ensure the safety of the installation, the presence of circuitry with DC component as well as additional leakage currents introduced by the use of variable frequency drive(s) in the unit must be considered (options 28, 17 & 30XBE range). In particular these protection devices shall be
  - suitable for protection of circuitry with AC and DC components
  - of reinforced immunity types and have a threshold not lower than 150mA.
- Capacitors that are integrated as part of the option 231 can generate electrical disturbances in the installation the unit is connected to. Presence of these capacitors must be considered during the electrical study prior to the start-up.

**NOTE: If particular aspects of an actual installation do not conform to the conditions described above, or if there are other conditions which should be considered, always contact your local Carrier representative.**

\* The required protection level for this class is IP43BW (according to reference document IEC 60529). All 30XB & XBP units are protected to IP44CW and fulfil this protection condition.

\*\* These limits are modified for machines equipped with option/QM 231: Maximum ambient temperature : 45°C  
 Total Voltage harmonic distortion : 3%

## DIMENSIONS / CLEARANCES

### 30XBE 250 to 350, 30XBP250 to 350

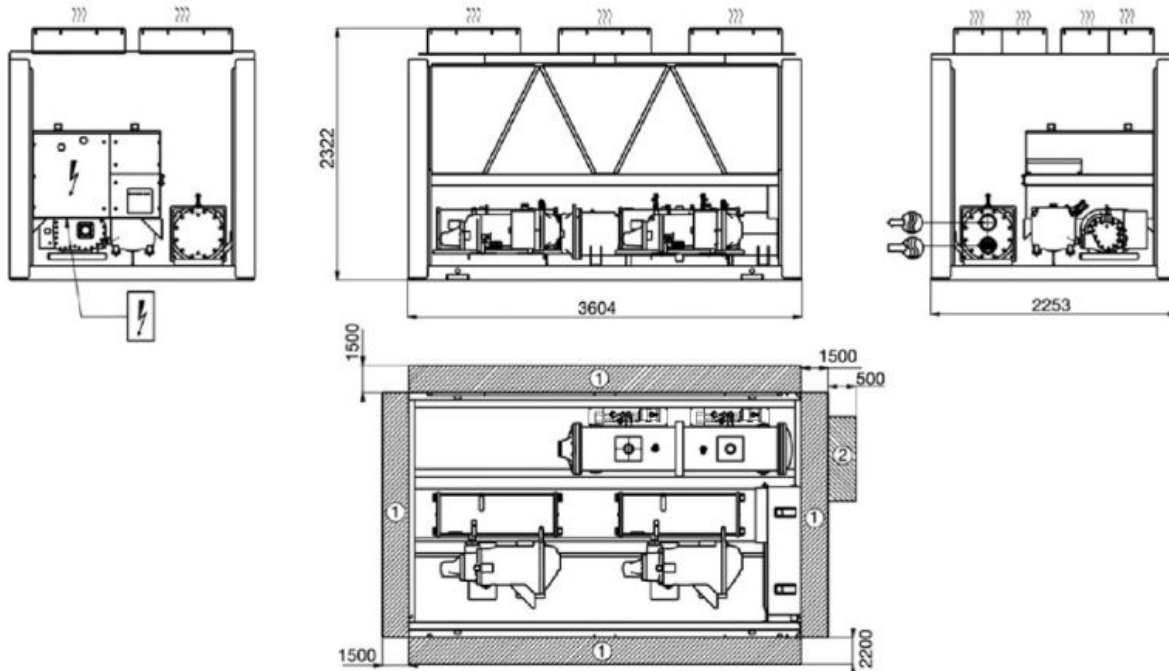

### 30XBE 400 to 500, 30XBP 400 to 450

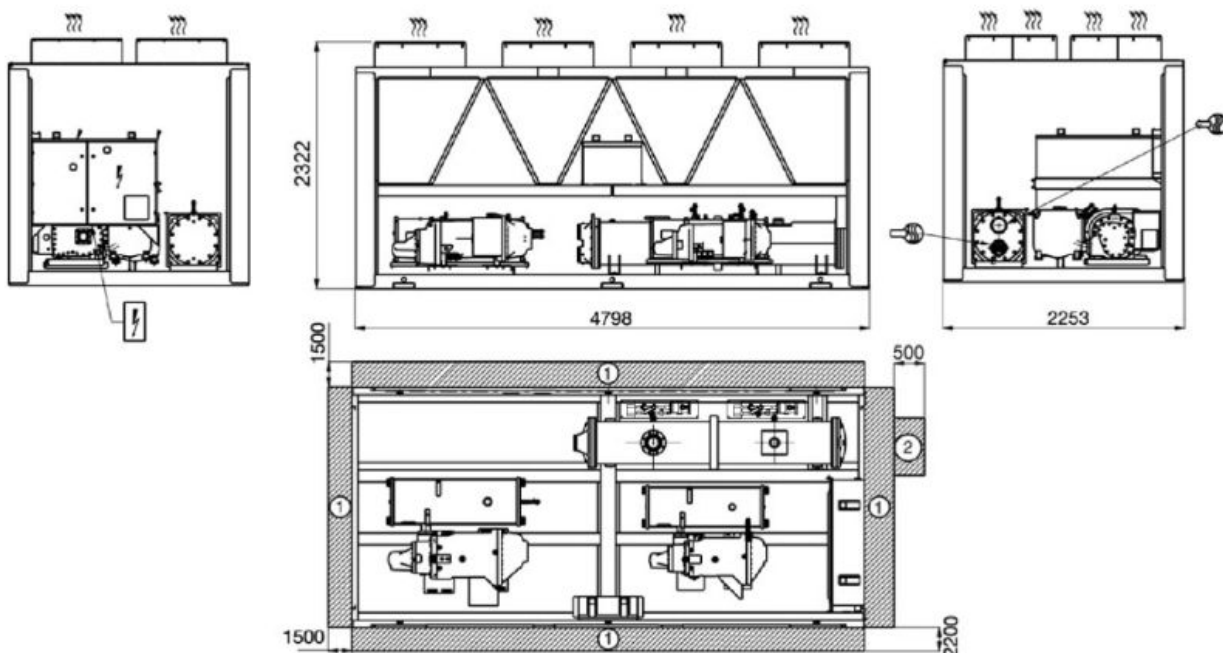

#### Legend

All dimensions are given in mm.

- ① Required clearances for maintenance (see note)
- ② Recommended space for evaporator tube removal
- Water inlet for standard unit - for options 100A, 100C, 107 refer to the certified drawing.
- Water outlet for standard unit - for options 100A, 100C, 107 refer to the certified drawing.
- Air outlet – do not obstruct
- Power supply and control connection

#### NOTES:

- Drawings are not contractually binding.
- Before designing an installation, consult the certified dimensional drawings, available on request.
- If the installation includes several units or if this (these) is (are) close to walls, please refer to chapters 3.13 - "Multiple chiller installation" and 3.14 - "Distance to the wall" of the installation manual to determine the space required

## DIMENSIONS / CLEARANCES

30XBP 500, 30XBE 500, 50 (heat recovery) or 118A (free cooling)

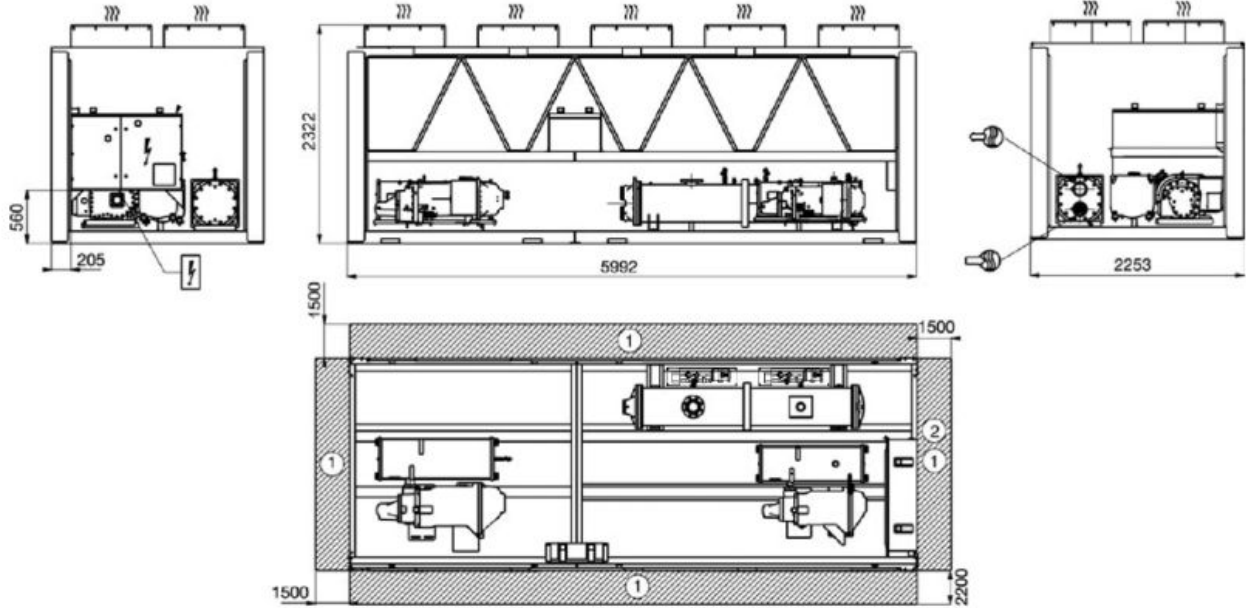

30XBE 600 to 900, 30XBP 600 to 800

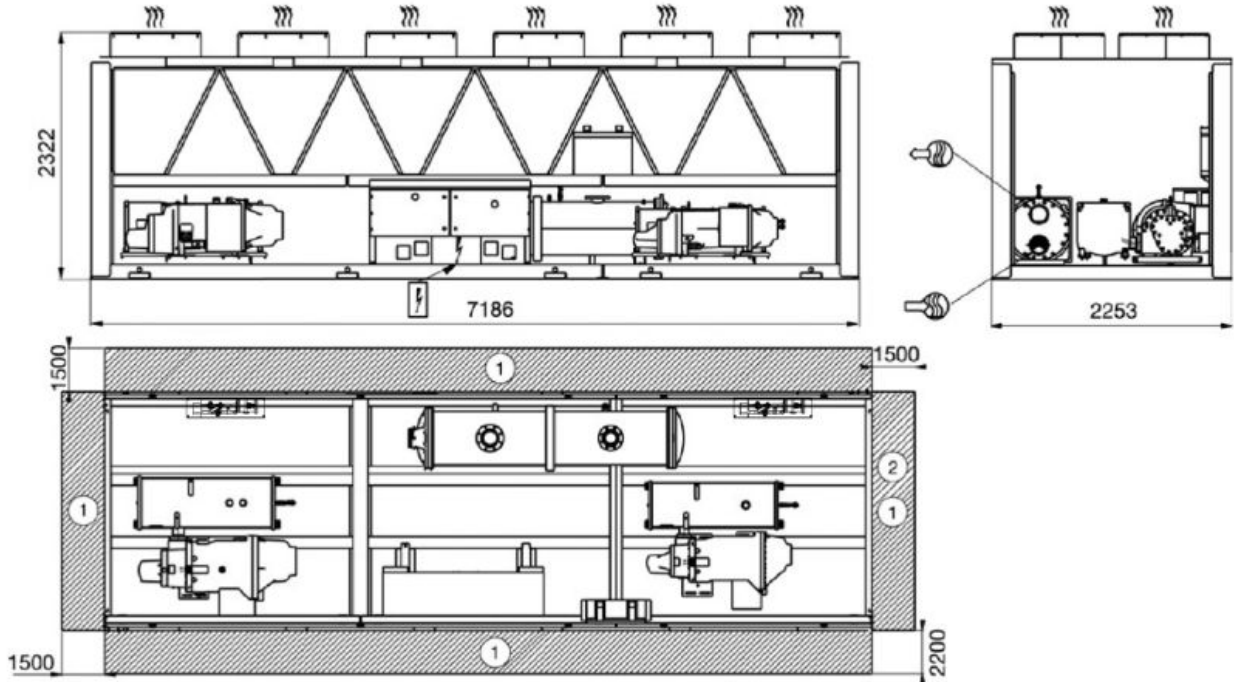

**Legend**

All dimensions are given in mm.

- ① Required clearances for maintenance (see note)
- ② Recommended space for evaporator tube removal
- Water inlet for standard unit - for options 100A, 100C, 107 refer to the certified drawing.
- Water outlet for standard unit - for options 100A, 100C, 107 refer to the certified drawing.
- Air outlet – do not obstruct
- Power supply and control connection

**NOTES:**

- Drawings are not contractually binding.
- Before designing an installation, consult the certified dimensional drawings, available on request.
- If the installation includes several units or if this (these) is (are) close to walls, please refer to chapters 3.13 - "Multiple chiller installation" and 3.14 - "Distance to the wall" of the installation manual to determine the space required



## DIMENSIONS / CLEARANCES

### 30XBE 900, 30XBP 850 & 900, 30XBE 850 with option 50 or 118A

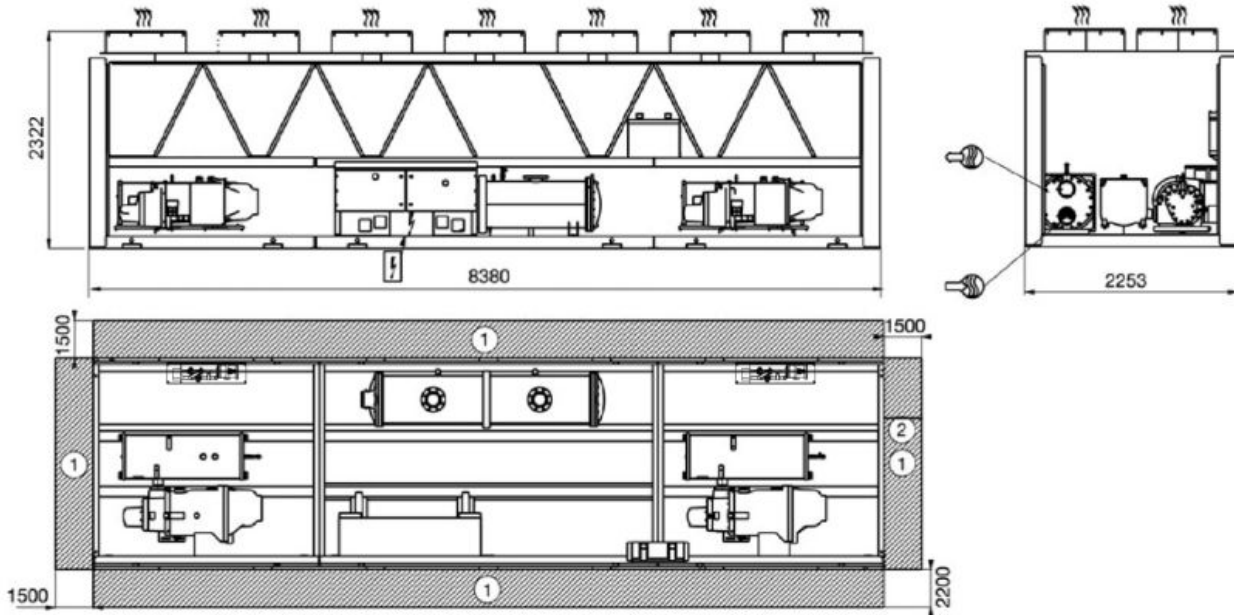

### 30XBE 1000, 30XBP 1000

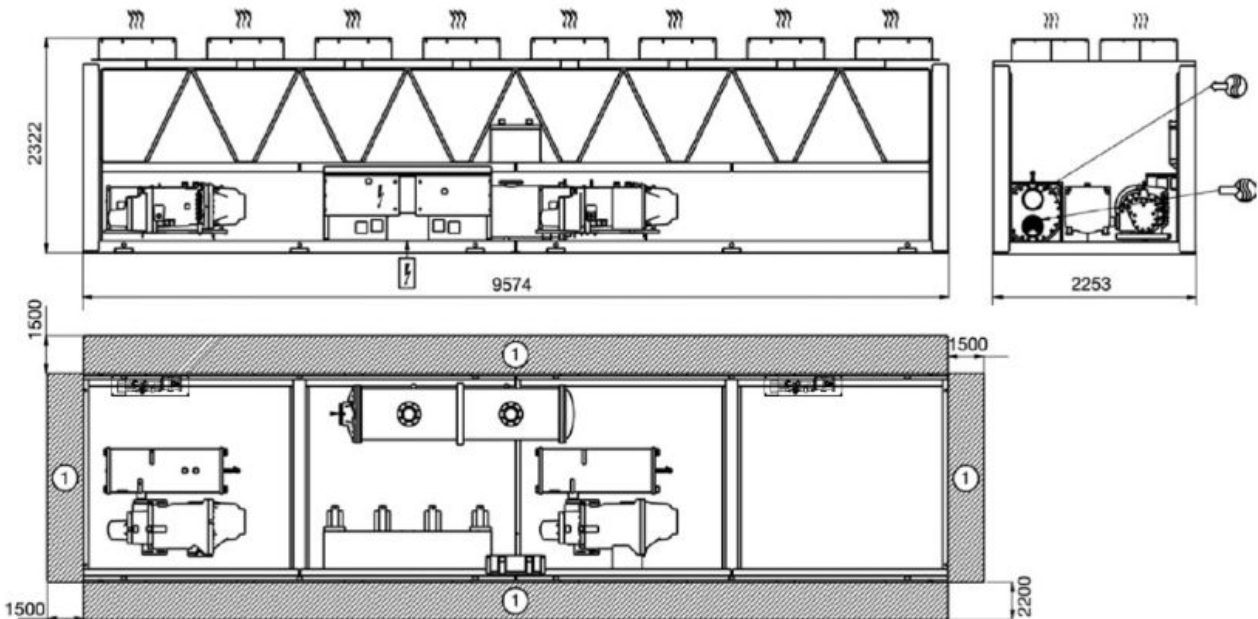

**Legend**

All dimensions are given in mm.

- ① Required clearances for maintenance (see note)
- ② Recommended space for evaporator tube removal
- Water inlet for standard unit - for options 100A, 100C, 107 refer to the certified drawing.
- Water outlet for standard unit - for options 100A, 100C, 107 refer to the certified drawing.
- Air outlet – do not obstruct
- Power supply and control connection

**NOTES:**

- Drawings are not contractually binding.
- Before designing an installation, consult the certified dimensional drawings, available on request.
- If the installation includes several units or if this (these) is (are) close to walls, please refer to chapters 3.13 - “Multiple chiller installation” and 3.14 - “Distance to the wall” of the installation manual to determine the space required

**DIMENSIONS / CLEARANCES**

**30XBE 1100 to 1400,  
30XBP 1100 to 1400**

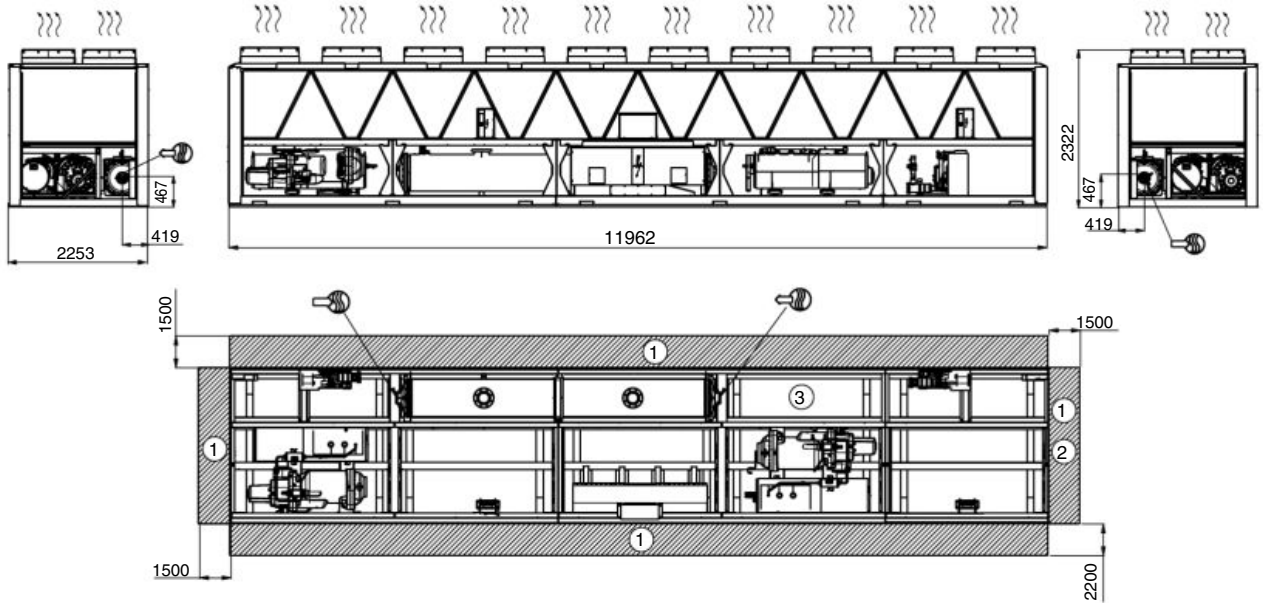

**30XB1500, 30XBP1500**

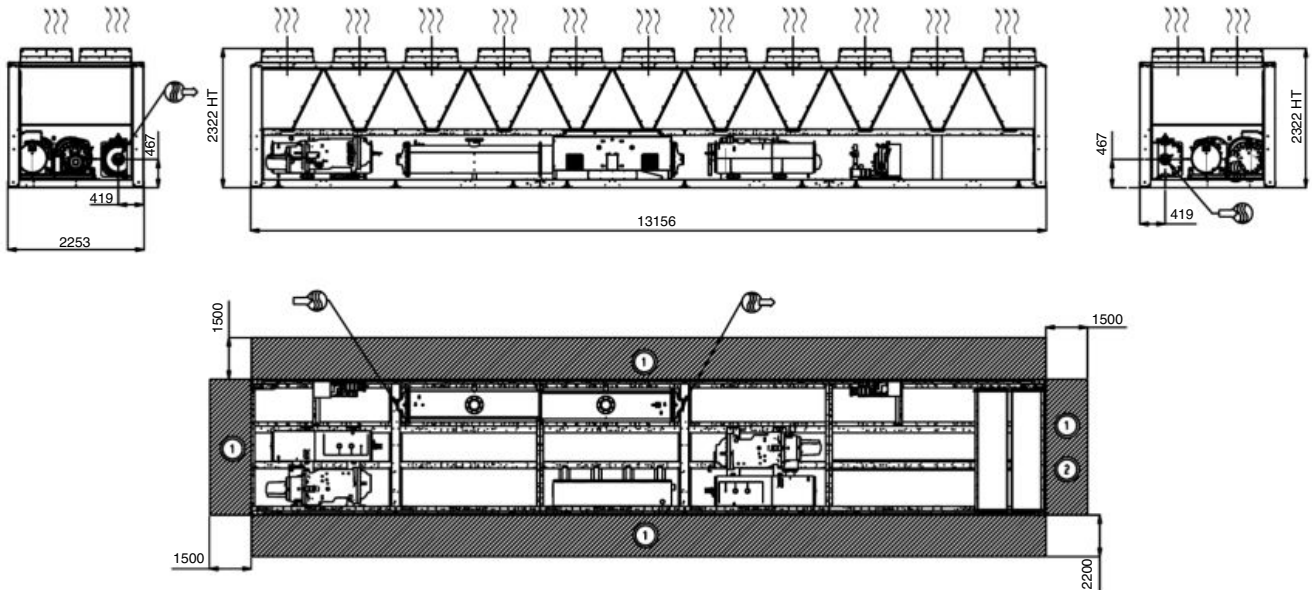

**Legend**

All dimensions are given in mm.

- ① Required clearances for maintenance (see note)
- ② Recommended space for evaporator tube removal
- Water inlet for standard unit - for options 100A, 100C, 107 refer to the certified drawing.
- Water outlet for standard unit - for options 100A, 100C, 107 refer to the certified drawing.
- Air outlet – do not obstruct
- Power supply and control connection

**NOTES:**

- Drawings are not contractually binding.
- Before designing an installation, consult the certified dimensional drawings, available on request.
- If the installation includes several units or if this (these) is (are) close to walls, please refer to chapters 3.13 - "Multiple chiller installation" and 3.14 - "Distance to the wall" of the installation manual to determine the space required



## DIMENSIONS / CLEARANCES

### 30XBE 1700 module 1/2

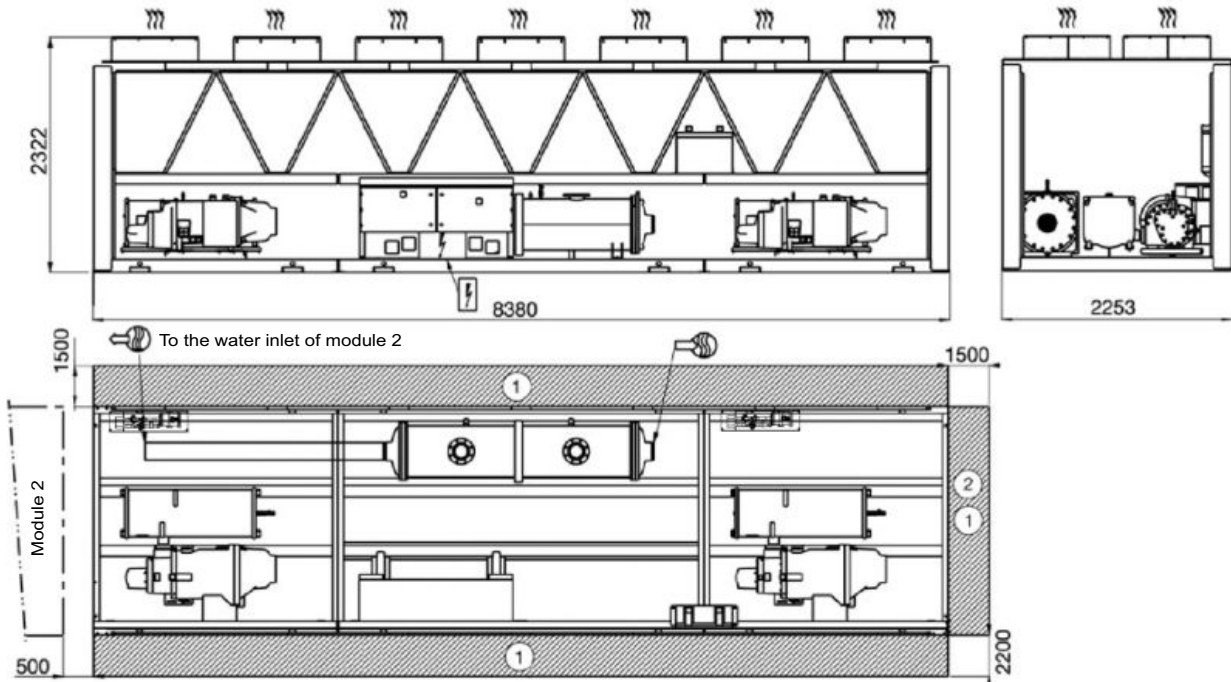

### 30XBE 1700 module 2/2

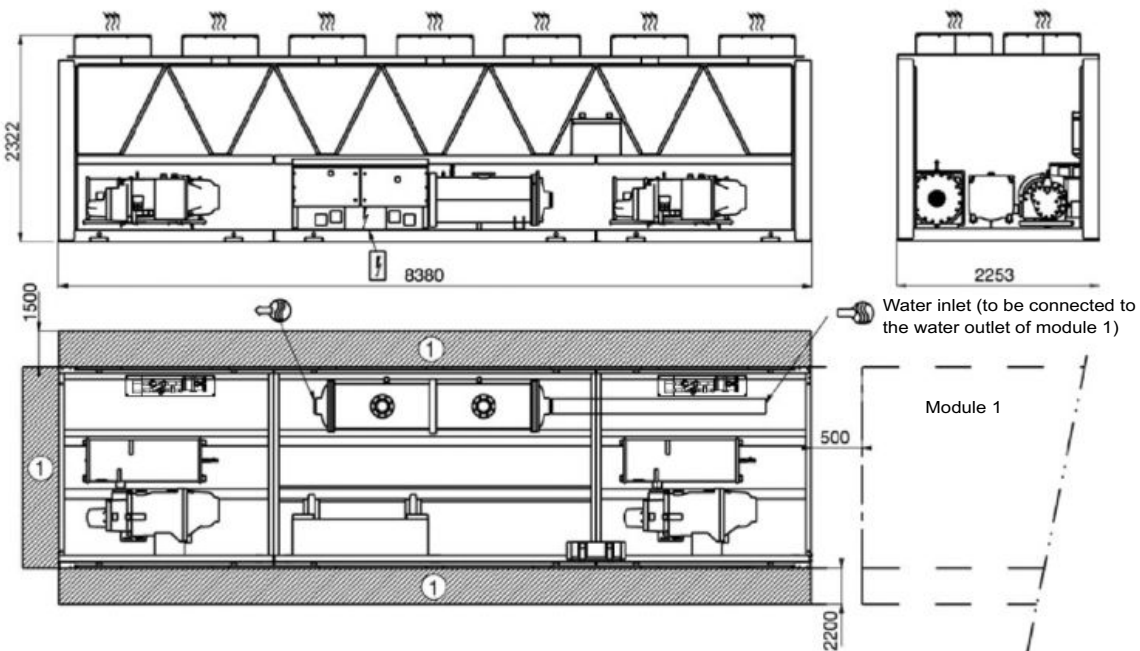

**Legend**

All dimensions are given in mm.

- ① Required clearances for maintenance (see note)
- ② Recommended space for evaporator tube removal
- Water inlet for standard unit - for options 100A, 100C, 107 refer to the certified drawing.
- Water outlet for standard unit - for options 100A, 100C, 107 refer to the certified drawing.
- Air outlet – do not obstruct
- Power supply and control connection

**NOTES:**

- Drawings are not contractually binding.
- Before designing an installation, consult the certified dimensional drawings, available on request.
- If the installation includes several units or if this (these) is (are) close to walls, please refer to chapters 3.13 - "Multiple chiller installation" and 3.14 - "Distance to the wall" of the installation manual to determine the space required



**NEW**

## VARIABLE-SPEED SCREW LIQUID CHILLER WITH GREENSPEED® INTELLIGENCE

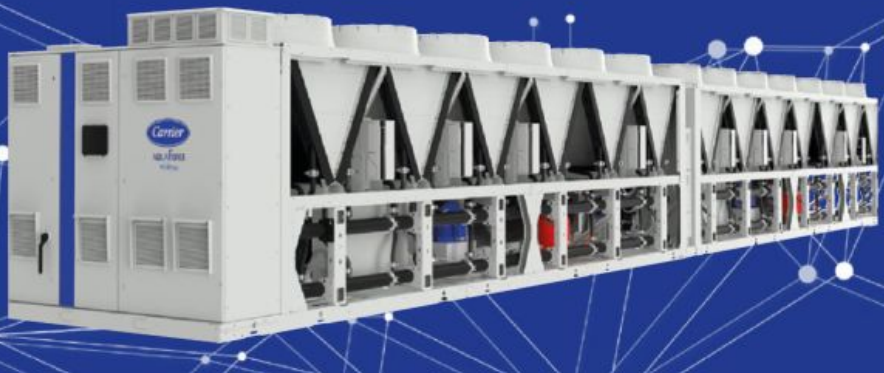

- Designed for Data Centers & Process applications
- Built-in free-cooling
- Outstanding performances
- Reduction of energy consumption
- Service continuity & redundancy
- Environmental responsibility

# 30XF



Nominal cooling capacity <sup>(1)</sup>: 390 - 2100 kW

The AquaForce® 30XF with Greenspeed® intelligence and PUREtec™ refrigerant is the premium solution dedicated for Data centers and Process applications.. Designed with integrated free-cooling and variable speed screw compressor with ultra-low GWP R-1234ze refrigerant, the 30XF is achieved through the optimised combination of proven best-in-class technologies that include:

- Ultra-low GWP HFO R-1234ze
- Outstanding performances :
  - 2nd generation of high-efficiency variable-speed twin screw compressors with built in volume index control (Vi) valve for optimal full and part-load performance and integrated Resonator Array (IRA) for low sound operation.
  - Total Current Harmonic Filter/Suppression <5%
  - Carrier flooded shell-and-tube evaporator with new copper tubes for low pressure drops
- Reduction of energy consumption :
  - Free-Cooling with glycol or glycol free
  - Variable speed pumps on glycol free option to increase the performances during free cooling mode and mixed mode
- Service continuity & redundancy : Ultra-fast cooling capacity recovery <120s - optimization of the buffer tank size
- Built-in solution : Integrated free-cooling and active harmonic filters. No external components to facilitate the transportation

(1) Unit size 400, 450, 600, 1100, 1250, 1400 & 1500 available in Q3 2024.



CARRIER participates in the ECP programme for LCP-HP  
Check ongoing validity of certificate:  
[www.eurovent-certification.com](http://www.eurovent-certification.com)

## AQUAFORCE® WITH PURETEC™ REFRIGERANT

### SUSTAINABILITY

PUREtec™: the environmental excellence solution

#### ■ GWP<1\*

Carrier has selected HFO R-1234ze as the best refrigerant to replace HFC R-134a on screw chillers and heat-pumps.

HFO R-1234ze **offers a Global Warming Potential (GWP) index below 1**, similar to that of natural substances (CO<sub>2</sub> GWP=1).

\* According to AR5 from the IPCC (International Panel on Climate change)

#### ■ High efficiency

This excellent efficiency performance in turn means a **lower total carbon footprint**, with a reduction of 10% compared to HFC R-134a and HFC blends such as R-513A.

#### ■ Regulation compliance

Carrier has made the strategic decision to choose a long-term solution for its new chiller and heat-pump ranges using screw compressors: **HFO R-1234ze, with a GWP<1, is not impacted by the F-gas Regulation.**

## AQUAFORCE® 30XF CUSTOMER BENEFITS



### REDUCTION OF ENERGY CONSUMPTION

Free cooling Carrier system could reduce the energy consumption by 50%. When outside temperature is low enough, the compressors are switched off and only the fans are in operation. EER with free cooling can reach an EER of 30.



### SERVICE CONTINUITY & REDUNDANCY

Carrier ultra fast capacity recovery option allows a 100% recovery below 120s in case of a power outage. This low period of time offers the possibility to reduce the size of the buffer tanks.

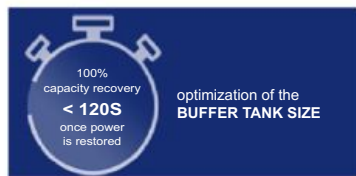

### BUILT-IN SOLUTION

Hydraulic free cooling and active harmonic filters are built inside the Aquaforce 30XF unit to facilitate the transportation and the installation.

No external component to facilitate the installation



### ■ Environmental responsibility

AquaForce® 30XF uses ultra-low global warming potential (GWP <1) HFO R-1234ze refrigerant. Combining reduced refrigerant charge and exceptional energy efficiency, it significantly lowers energy consumption while reducing CO<sub>2</sub> emissions throughout its life cycle.



HFO R-1234ze refrigerant with direct CO<sub>2</sub> impact reduced by 99.9% compared to R-134a and 99.8% compared to R-513A

### ■ Intelligence and connectivity

The advanced SmartVu™ intelligent control displays the service parameters in real time, for an intuitive and particularly user-friendly use. The 30XF range is also characterized by an innovative intelligent energy monitoring function, which provides users with intelligent data such as real-time electrical energy consumption, cooling capacity, as well as instantaneous and average values of the real energy efficiency of the machine. To go further in terms of energy savings, the 30XF range can be monitored remotely by Carrier experts, in order to carry out a diagnosis and optimize electricity consumption.



SMART ENERGY MONITORING

### ■ Low sound levels

The new generation of Carrier 06Z variable-speed twin screw compressor with integrated resonance attenuator and the 6th generation of Flying Bird™ fans with new fan blade design inspired by nature help to significantly reduce compressor and fan noise. As an option, the 30XF chiller can be fitted with an acoustic cover for the screw compressor to achieve very low noise levels.



90 dB(A)



## AQUAFORCE® 30XF CUSTOMER BENEFITS

AquaForce® liquid chillers with Greenspeed® Intelligence adapt effortlessly to a wide range of applications. An extended operating range covering ambient temperatures from -20 to 55°C makes it ideal for all areas of activity. From high-end office buildings and hotels to healthcare facilities, data centers and industrial projects, 30XF ranges meets the most demanding expectations in terms of energy efficiency and savings, whatever the climate and wherever the location.

Furthermore, the advanced SmartVu™ intelligent control system displays operating parameters in real time, making it intuitive and particularly user-friendly. 30XF ranges also features innovative smart energy monitoring, providing users with smart data such as real time electric energy consumption, cooling capacity, and instantaneous and average seasonal energy efficiency ratios as well as smart refrigerant leak alert that can indicate significant loss of refrigerant at any point of the system.

For further energy savings, AquaForce® can be monitored remotely by Carrier experts for energy consumption diagnosis and optimization.

### Outstanding energy performance

- The high energy efficiency is achieved through:
  - 2nd generation of Carrier high-efficiency variable-speed
  - Twin-screw compressors with built in volume index control (Vi) valve for both optimal full and part load performance
  - Variable-speed Flying Bird™ fans with AC motor
  - Minimising power consumption while delivering optimum air flow
  - Novation™ aluminum condenser with high-efficiency micro-channel coils technology
  - New Carrier flooded shell-and-tube evaporator with new copper tubes for low pressure drops
  - Electronic expansion device permitting operation at a lower condensing pressure and improved utilisation of the evaporator heat exchange surface (superheat control)
  - Economiser system with electronic expansion device for increased cooling capacity.
- Optimised electrical performance:
  - Negligible start-up current (value is lower than the maximum unit current draw)
  - High displacement power factor (above 0.98)
  - EMC compliance with Class 3 requirements of the EU standard EN61800-3 (Class 2 is possible as an option).
- Hydraulic module with variable-speed pump
  - Variable-speed, single pumps which automatically adjust the water flow to match the needs of the building or process load variations
  - 3 pump control modes available: constant water flow with possibility to reduce the pump speed when there is no cooling demand, variable water flow with constant delta T or constant delta P control.

- Smart energy monitoring
  - Innovative smart energy monitoring providing users with smart data such as real time electric energy consumption, cooling capacity, and instantaneous and average seasonal energy efficiency ratios (Electricity metering accuracy: +/-5%. Cooling capacity metering accuracy: +/-5% at nominal rated conditions).
  - For further energy savings, 30XF ranges can be monitored remotely by Carrier experts for energy consumption diagnosis and optimization.

### Built-in reliability and easy servicing

The AquaForce® offer enhanced performances as well as Carrier's acclaimed product quality and reliability. Major components were chosen, selected and tested to minimize the possibility of failure.

- 2nd generation of variable-speed twin-screw compressors:
  - The screw compressors are industrial-type with oversized bearings and motor cooled by suction gas, with a proven failure rate lower than 0.1%.
  - Synchronous motor spins at supplied frequency, without any slip and rotor losses to induce magnetic field. There is a benefit of +1% in full load efficiency and of +4% in part load efficiency compared to induction motors.
  - 30XF is fitted with a Permanent Magnet (PM) motor to run the variable screw compressor (option)
  - Air-cooled compressor variable-speed drive (VSD) to ensure reliable operation.
  - Compressor bearing life exceeding 100 000 hours
  - All components related to the compressor assembly are easily accessible on site minimising down-time.

#### ■ Variable-speed fans:

30XF are fitted with variable-speed asynchronous fan-motors as standard. One variable-speed drive (VSD) is sized to manage a group of fans per refrigerant circuit reducing first cost while ensuring high part-load efficiency.

#### ■ Air-cooled condenser:

- Novation™ aluminum micro-channel heat exchanger (MCHE) with high corrosion resistance. The all aluminum design eliminates the formation of galvanic currents between aluminum and copper that cause coil corrosion in saline or corrosive environments.
- Enviro-shield™ coating for MCHE used in standard and mildly corrosive environments with superior durability confirmed through 5000 hours testing in constant neutral salt spray per ASTM B117 and superior heat transfer performances confirmed through 2000 hours testing per CM1 (Carrier proprietary testing).
- Super Enviro-shield™ coating for MCHE used in highly corrosive environments (industry or marine applications) with superior durability confirmed through 5000 hours testing in constant neutral salt spray per ASTM B117 and superior heat transfer performances confirmed through 2000 hours testing per CM1 (Carrier proprietary testing).

## AQUAFORCE® 30XF CUSTOMER BENEFITS

- **Evaporator:**
  - Carrier designed flooded evaporator with mechanically cleanable water tubes
  - Electronic paddle-free flow switch to ensure prompt alarm in case of poor liquid flow rate
  - Thermal insulation with aluminum sheet finish (option) improved resistance to mechanical and UV damage.
- **Refrigerant circuits:**
  - Two independent refrigerant circuits for duplex units to secure partial cooling, if one of the two develops a fault.
- **Auto-adaptive control:**
  - Control algorithm prevents excessive compressor cycling (Carrier patent)
  - Automatic compressor unloading in case of abnormally high condensing pressure. If condenser coil fouling or fan failure occurs, the Aquaforce continues to operate, but at reduced capacity.
- **Exceptional endurance tests:**
  - To design critical components and sub-assemblies to minimise the risk of failure on site, Carrier uses specialized laboratories and advanced dynamic simulation tools.
  - To ensure that the units reach customer sites in the same condition as they are when tested in the factory, Carrier tests the machine behavior while being moved along a 250 km trial. The test-route is based on a military standard and is the equivalent to 5000km by truck in a normal road.
  - To ensure coils corrosion resistance, salt mist corrosion resistance test are performed in Carrier's laboratory.

In addition, to maintain unit performance throughout its operating life, whilst minimising maintenance costs, end users can access the "Carrier Connect" remote monitoring service.

### Minimised operating sound levels

- The Greenspeed® Intelligence, featuring variable-speed screw compressors and condenser fans, minimises noise levels at part load operation.

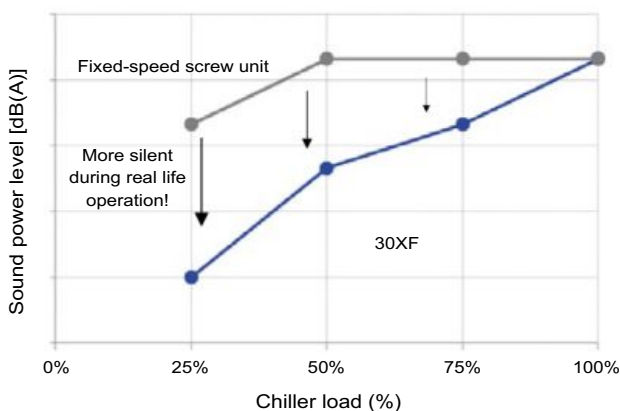

- **Standard unit features include:**
  - The new generation of Carrier 06Z variable-speed twin screw compressor with integrated resonator array to reduce the noise level by 6 dB(A) compared with 06T twin screw compressor previous generation.
  - The 6<sup>th</sup> generation of silent Flying Bird™ fans with new fan blade design inspired by nature, help reduce airflow noise.

- AquaForce® is available with 3 sound levels to match the most sensitive environments:
  - Standard: standard unit configuration with new generation of low sound screw compressor and fans
  - Low noise option: addition of high-performance compressor sound enclosure
  - Very low noise option: addition of high-performance compressor sound enclosure and fan operation at lower rotational speed.

### Easy and fast installation

- **Built-in variable speed pumps**
  - Full hydraulic module with pumps
  - Automatic nominal water flow adjustment through electronic control on the user display
- **No external component for easy transportation and installation.**
  - Built-in free cooling & active harmonic filters
- **Flexible electrical connections:**
  - Single or dual electrical point of connection
  - Single or dual disconnect switch
- **Simplified water connections:**
  - Victaulic connections on the evaporator
  - Clearly identified entering and practical reference marks for entering and leaving water connections
- **Fast commissioning:**
  - Systematic factory operating test before shipment
  - Functional test for main components, expansion valves, fans and compressors.

### Environmental care

- The AquaForce® with PUREtec™ refrigerant liquid chillers with Greenspeed® Intelligence is a boost for green cities and contributes to a sustainable future. Combining a reduced charge of R-1234ze refrigerant and exceptional energy efficiency it significantly lowers energy consumption while reducing carbon dioxide emissions by 25% throughout its life cycle (compared to previous fixed-speed screw liquid chiller generation).
- The AquaForce® with PUREtec™ refrigerant liquid chiller is equipped with an automatic energy meter that provides estimated instantaneous and cumulative cooling energy output, instantaneous and cumulative electric energy consumption, instantaneous and average seasonal energy efficiency ratios (Accuracy: +/- 5% at nominal condition, +/-10% elsewhere) for unit performance monitoring and verification.
- **R-1234ze: HFO refrigerant with zero ozone depletion potential**
- **40% less refrigerant charge:** The micro-channel technology used for condenser coils optimises heat transfer while minimising the refrigerant volume.

## AQUAFORCE® 30XF CUSTOMER BENEFITS

- Leak tight refrigerant circuits:
  - Reduction of leaks as no capillary tubes and flare connections are used
  - Verification of pressure transducers and temperature sensors without transferring refrigerant charge
  - Discharge line shut-off valve and liquid line service valve for simplified maintenance (option 92).
- Refrigerant leak alert: The AquaForce® liquid chiller is equipped with an automatic refrigerant leak detection algorithm that can detect serious refrigerant loss at any point on the system (Sensitivity: 25% refrigerant charge loss per circuit, depending on the conditions). The automatic refrigerant leak detection system can help to achieve recognition within pollution prevention assessment programs, ideal for assisting in the design of sustainable buildings.
- Refrigerant leak detection: Available as an option, this additional dry-contact allows reporting of possible leaks. The leak detector (by others) should be mounted in the most likely leak location.



- R-1234ze long-term refrigerant solution
  - HFO refrigerant with nearly zero global warming potential (GWP<1 following AR5) and zero ozone depletion potential (ODP = 0).
  - Not impacted by the HFC phase-down plan in Europe (79% HFC reduction in EU member states at 2030 horizon)
  - Compliant with refrigerant regulation in Switzerland that bans the use of HFC refrigerant in large capacity airconditioning equipment.

### Designed to support Green Building Design

A green building is a building that is environmentally sustainable and has been designed, constructed and is operated to minimise the total impact on the environment.

The resulting building will be economical to operate, offer increased comfort and create a healthier environment for the people who live and work there, increasing productivity.

The air conditioning system can use between 30 and 40% of the annual building energy consumption. Selection of the right air conditioning system is one of the main aspects to consider when designing a green building. For buildings with a variable load throughout the year AquaForce® offer a solution to this important challenge.

A number of green building certification programs exist in the market and offer third-party assessment of green building measures for a wide variety of building types.

The following example looks at how Carrier's new AquaForce® range helps customers involved in LEED® building certification.

The other benefit of using the AQUAFORCE PUREtec™ products is the eligibility for BUILDING labeling programs like BREEAM, HQE in France or Green Building Council labelling, that are recognizing the use of sustainable heating and air-conditioning equipment.

Let's take the example of BREEAM assessment method for the sustainability of buildings.

Two credits can be awarded where the refrigerants used in air-conditioning systems have a Global Warming Potential below 10.

And one additional credit can be awarded where the systems have a low Total Equivalent Warming Impact.

AQUAFORCE PUREtec™ is not only a solution that is reducing the energy bill and the CO<sub>2</sub> footprint.

It also helps the green certification of your buildings!

### Energy saving certificate

AquaForce® with with PUREtec™ refrigerant is eligible to Energy savings certificates in France (CEE) in comfort, industrial and agriculture applications:

- Floating High pressure control (by modulating the air flow through fan activation and its speed)
- Floating Low pressure control
- Variable speed on asynchronous compressor motor
- Variable speed on asynchronous fan motor
- Variable speed on asynchronous pump motor

30XF is equipped with variable speed asynchronous (standard) or synchronous (option 329) compressor motor

For more details about financial incentives in France, please refer to "Fiche produit CEE"

## 30XF TECHNICAL INSIGHTS

### POWERFUL SMART ENERGY MONITORING FUNCTION

- Provides smart data based on intelligent algorithms
- Real time energy consumption measurement (kWh)
- Cooling energy output measurement (kWh)
- Instantaneous and average Energy Efficiency Ratio under real operating conditions
- Remote monitoring with Carrier Connect

### ADVANCED SMARTVU™ WITH 7 INCH COLOR TOUCH SCREEN INTERFACE

- Exclusive Carrier design
- 10 languages available: DE, EN, ES, FR, IT, NL, PT, TR, TU + one additional customer choice
- Touch screen user interface
- BACnet, J-Bus or LON communication interfaces
- Optional wireless connectivity

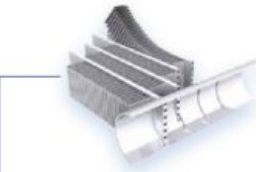

### 3RD GENERATION OF NOVATION® MICRO CHANNEL HEAT EXCHANGERS

- Exclusive Carrier design
- Increased reliability with new aluminum alloy
- Significantly reduces refrigerant charge (-40% vs cu/al coils)
- Enviro-shield™ coating for mildly corrosive environments
- Super Enviro-shield™ coating for highly corrosive environments (industry or marine applications)
- Easy cleaning with high pressure air or water washer



### 6TH GENERATION OF VARIABLE-SPEED FLYING BIRD™ FANS WITH AC MOTOR

- Exclusive Carrier design
- Fan blade design inspired by nature
- AC motor technology

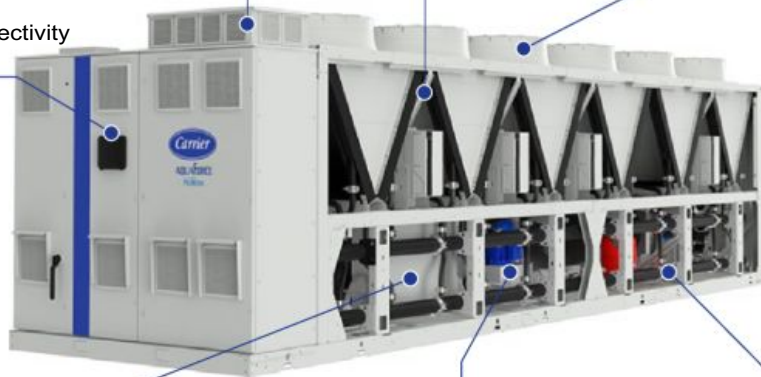

### FLOODED SHELL AND TUBE EVAPORATOR

- Exclusive Carrier design
- Flooded technology for high energy efficiency
- New generation of copper tubes with specific profile to reduce pressure drops when operating with glycol
- High efficiency evaporator with higher  $\Delta T$  design

### LATEST GENERATION CARRIER VARIABLE-SPEED 06Z TWIN SCREW COMPRESSOR WITH AC MOTOR

- Exclusive Carrier design
- Twin screw compressor designed for variable speed operation
- High efficiency AC motor
- Stepless variable-speed control (0%-100%)
- Integrated resonator array for compressor acoustic attenuation
- Integrated check valve for quiet shutdown
- Air-cooled inverter drive for increased reliability
- Bearing life exceeding 100.000 hours
- Twin screw compressor with permanent magnet motor as option



### BUILT-IN FREE COOLING SYSTEM

- Integrated Free-Cooling
- Total hydraulic Free-Cooling
- Glycol free option with variable speed pump



## TECHNICAL INSIGHTS

### SmartVu™ Control (standard)

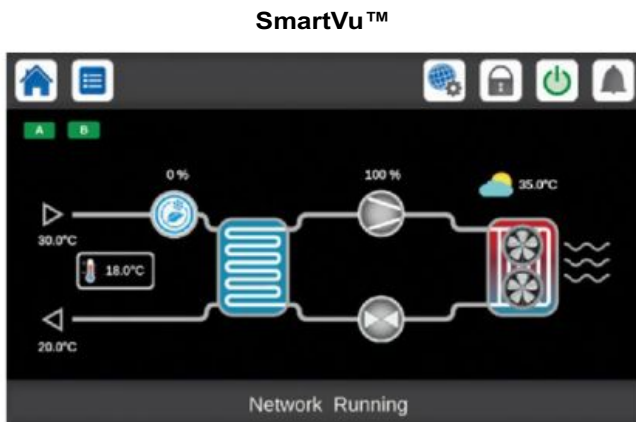

- New innovative smart control features:
  - An intuitive and user-friendly, coloured, 7" interface
  - 10 languages available on choice: DE, EN, ES, FR, IT, NL, PT, TR, TU + one additional customer choice
  - Screen-shots with concise and clear information in local languages
  - Complete menu, customised for different users (end user, service personnel and Carrier-factory technicians)
  - Setpoint offset based on the outside air temperature
  - Safe operation and unit setting: password protection ensures that unauthorised people cannot modify any advanced parameters
  - Simple and "smart" intelligence uses data collection from the constant monitoring of all machine parameters to optimise unit operation
  - Night-mode: cooling capacity management for reduced noise level.
  - With hydraulic module: water pressure display and water flow rate calculation.
- Energy management:
  - Innovative smart energy monitoring, providing users with smart data such as real time electric energy consumption, cooling capacity, and instantaneous and average seasonal energy efficiency ratios.
  - Internal time schedule clock controls chiller on/off times and operation at a second set-point
  - The DCT (Data Collection Tool) records the alarms history to simplify and facilitate service operations.
- Maintenance functions
  - F-Gas regulation leak check reminder alert
  - Maintenance alert can be configured to days, months or hours of operation
- Advanced communication features
  - Easy and high-speed communication technology over Ethernet (IP) to a centralised building management system
  - Access to multiple unit parameters.

### Remote management (standard)

- Units with SmartVu™ control can be easily accessed from the internet, using a PC with an Ethernet connection. This makes remote control quick and easy and offers significant advantages for service operations.
- AquaForce with Greenspeed® Intelligence is equipped with an RS485 serial port that offers multiple remote control, monitoring and diagnostic possibilities. When networked with other Carrier equipment through the CCN (Carrier Comfort Network - proprietary protocol), all components form a HVAC system fully-integrated and balanced through one of the Carrier's network system products, like the Chiller System Manager or the Plant System Manager (optional).
- Units also communicates with other building management systems via optional communication gateways (BACnet, LON or JBus).
- The following commands/visualisations are possible from remote connection:
  - Start/Stop of the machine
  - Dual set-point management: through a dedicated contact is possible to activate a second set-point (example, unoccupied mode)
  - Demand limit setting: to limit the maximum chiller capacity to a predefined value
  - Water pump control: these outputs control the contactors of one/two evaporator water pumps.
  - Water pumps changeover (only with hydraulic module options): these contacts are used to detect a water pump operation fault and automatically change over to the other pump.
  - Operation visualisation: indication if the unit is operating or if it is in stand-by (no cooling load)
  - Alarm visualisation

### Remote management (EMM option)

- The Energy Management Module (EMM) offers extended remote control possibilities:
  - Room temperature: permits set-point reset based on the building indoor air temperature (if Carrier thermostats are installed)
  - Set-point reset: allows reset of the cooling set-point based on a 4-20 mA.
  - Demand limit 1 and 2: closing of these contacts limits the maximum chiller capacity to two predefined values.
  - User safety: this contact can be used for any customer safety loop; opening the contact generates a specific alarm.
  - Ice storage end: when ice storage has finished, this input permits return to the second set-point (unoccupied mode).
  - Time schedule override: closing of this contact cancels the programmed time schedule.
  - Out of service: this signal indicates that the chiller is completely out of service.
  - Chiller capacity: this analogue output (0-10 V) gives an immediate indication of the chiller capacity.
  - Alert indication: this volt-free contact indicates the necessity to carry out a maintenance operation or the presence of a minor fault.
  - Compressors running status: set of outputs (as many as the compressors number) indicating which compressors are running.



## TECHNICAL INSIGHTS

### New generation of Carrier 06Z variable-speed twin screw compressor



The new generation of 06Z variable-speed twin screw compressors benefits from Carrier's long experience in the development of twin-rotor screw compressors. The 06Z compressor design is based on the successful 06T screw compressor, core of the well-known AquaForce series with a number of modifications to reduce noise level and improve the energy efficiency especially during part-load operation.

**Power Factor 0.98** is one benefit of Carrier technology choice using variable-speed compressor compared with power factor of 0.9 usually associated with fixed-speed compressor technology. High power factor close to 1 means that there is no energy lost in the distribution system thus, guaranteeing low power costs granted by electrical utilities, low energy costs and higher PUE of data centers.

- New 06Z twin screw compressor optimized for variable speed operation: elimination of the slide valve, built-in volume index control (Vi) valve for both optimal full and part-load performance, high efficiency AC motor with stepless inverter control from 20% to 100%.
- Separate air-cooled inverter drive for increased reliability
- New 06Z twin screw compressor design with Integrated Resonator Array (IRA) to reduce the sound level by up to 6 dB(A) when compared with previous 06T generation
- Integrated Check Valve for quiet shutdown
- Bearing life exceeding 100 000 hours.
- A dedicated oil separator is installed at the discharge of each compressor to ensure maximum oil return: Oil separates from refrigerant by gravity and returns to the low pressure side of the compressor without use of additional pumps.
- Volume index control (Vi) valve provides a reliable method of adjusting the compression ratio to better match system demand. It provides optimal performance regardless of operating condition
- Screw compressors work on the positive displacement principle to compress gas to a higher pressure. As a result, if there is an unusually high pressure in the condenser (due for example to coil fouling or operation in harsh climate) the compressor does not switch off, but continues operation at reduced capacity (unloaded mode).
- The silencer in the oil separator line (at the compressor outlet) considerably reduces discharge gas pulsations for much quieter operation.

## TECHNICAL INSIGHTS

### Novation® Heat Exchangers with Microchannel Coil Technology

Already utilised in the automobile and aeronautical industries for many years, the Novation™ Micro-Channel Heat Exchanger (MCHE) used in the AquaForce is entirely made of aluminum. This one-piece concept significantly increases its corrosion resistance by eliminating the galvanic currents that are created when two different metals (copper and aluminum) come into contact in traditional heat exchangers.

- From the energy efficiency point-of-view the Novation® heat exchangers are approximately 10% more efficient than traditional coils and micro-channel coil technology allows a 40% reduction in the amount of refrigerant used in the chiller.
- The reduced depth of the Novation™ MCHE reduces air pressure losses by 50% and makes it much less susceptible to fouling (e.g. by sand). Cleaning of the Novation™ MCHE heat exchanger is very fast using a high pressure washer.
- To further enhance long-term performance, and protect coils from early deterioration, Carrier offers (as options) dedicated treatments for installations in corrosive environments.
  - The Novation™ MCHE with exclusive Super Enviro-Shield protection (option 263) is recommended for installations in corrosive environments. The Super Enviro-Shield protection consist of an extremely durable and flexible epoxy coating uniformly applied over all coil surfaces for complete isolation from the contaminated environment.
- After a total of more than 7,000 hours of testing following various test standards in Carrier laboratories, the Carrier Novation® MCHE with Super Enviro-shield® coating appears to be the best-suited customer choice to minimize the harmful effects of corrosive atmospheres and ensure long equipment life.
  - Best corrosion resistance per ASTM B117/D610 test
  - Best heat transfer performance per Carrier Marine 1 test
  - Proven reliability per ASTM B117 test

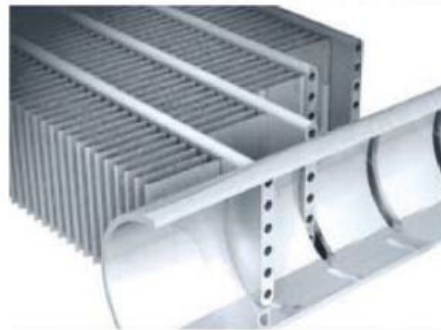

Coil Types (ranked by performance)	Visual Corrosion Evaluation	Heat Transfer Performance Degradation	Time to Failure	Test Campaign Conclusions
Super Enviro-shield® Novation™ MCHE	Very good	Very good	No coil leak	Best
Enviro-shield® Novation™ MCHE	Very good	Good	No coil leak	Very good
Novation™ MCHE	Good	Very good	No coil leak	Good

#### Ultra-fast capacity recovery (Option 295+)

In mission-critical applications like data centers, process cooling & the food industry, a delay in chiller restart and capacity regain following the restoration of electrical power may increase the water temperatures thus potentially affecting the desired operation. Normally additional water volume loop/system is deployed to overcome this.

Ultra-Fast Capacity Recovery™ is an innovative feature that ensures immediate restart of chiller operation following a power restoration & allows 100% capacity recovery in less than 120s. This will eliminate or significantly reduce the need for additional water volume.

Carrier chillers have led the industry for decades in rapid capacity recovery, with the fastest restart and recovery time. Carrier Ultra-Fast Capacity Recovery™ feature will continue to lead in this regard, delivering even more accelerated capability. This new capability has been made possible thanks to specific software and hardware integration.

#### Harmonics filter (Option)

Harmonics Electronic Filter can be selected to eliminate harmonics at the source (THD < 5%). This option consists in active electronic filters to maintain a low and safe level of harmonics to ensure power reliability, no energy lost in the distribution system and higher PUE of data centers.

## TECHNICAL INSIGHTS

### New Generation of Flying Bird VI fans



The 30XF utilize Carrier's 6<sup>th</sup> generation Flying Bird™ fan technology, engineered for maximum efficiency, super low noise, and wide operating range. The fan includes Carrier patented rotating shroud technology and back-swept blades with a unique wave-serration trailing edge inspired from nature.

It was designed and optimized for the 30XF air management system configuration and heat exchanger technology. The fan meets the latest European eco-design requirements for fan efficiency. The fan uses Carrier's robust and proven injection molded composite-thermoplastic construction.

### Variable Frequency Drives (VFD)

The compressors, AC fans and the pumps of AquaForce® are controlled by VFDs.

- Electrical box is capable of operating up to 55°C (with option 16 "High Ambient").
- Unit regulation is designed to withstanding storage temperatures in the control compartment from -20°C to 68°C.
- All VFDs on the chiller (compressors, fans and pumps motors) are fully air cooled

### Actual Major product modification 30XF :

1	2	3	4	5	6	7	8	9	10	11	12	13	14	15	16	17	18
3	0	X	F	-	Z	1	0	0	0	-	-	-	-	-	-	-	-

Product codification

- Digit 1-3: Air cooled Screw Chiller
- Digit 4: "F"=Free Cooling capability (available as an option)
- Digit 5: "-" = Standard Unit
- Digits 6: Refrigerant ('Z' = R1234ze)
- Digits 7 to 10: Number based on the cooling capacity in kW at water conditions +30/+20°C, outside air +35°C.
- Digit 11: Major product modification
- Digit 12 to 15: Counter used to generate a one time product code
- Digit 16: Used for TWO PIECES SHIPMENT '1' = module 1, '2' = module 2 and '-' for single piece

## OPTIONS

Option	N°	Description	Advantage	Use 30XF
High speed fans at 1140RPM	12B	Fans speed can be increased up to 1140RPM	Enhances the unit performances at high ambient temperature. Higher static pressure available (max 200Pa)	0400-2100
Low Noise	15	Aesthetic and sound absorbing compressor enclosure	Noise level reduction	0400-2100
Very Low Noise	15LS	Sound absorbing & aesthetic compressor enclosure and oil separator, evaporator and suction line acoustic treatment, combined with low-speed fans	Noise level reduction in sensitive environments	0400-2100
Enclosure panels	23A	Side enclosure panels	Improves aesthetics and piping protection against impacts.	0400-2100
Grilles and enclosure panels	23	Metallic protection grilles and side enclosure panels	Improves aesthetics, protection against intrusion to the unit interior, coil and piping protection against impacts.	
Water exchanger frost protection	41A	Electric resistance heater on the water exchanger and discharge valve	Water exchanger frost protection down to -20°C outside temperature	0400-2100
Evaporator & hydraulic module frost protection	41B	Electric resistance heater on water exchanger, discharge valve and hydraulic module	Water exchanger and hydraulic module frost protection down to -20°C outside temperature	0400-2100
Main disconnect switch with short-circuit protection	70D	Disconnect circuit breaker equipped with an external disconnect switch handle	Ensure protection of main disconnect switch and associated cables against short-circuits when building devices are not compliant	0400-2100
Dual Power Supply 400V/400V	85A	Power supply separated in two 400V feeds :Supply 1 (400V): Compressors & Fans / Supply 2 (400V) : Control, Main pumps & Heaters	Chiller can be connected on 2 separated power suppliesControl, main pumps & heaters can be connected to external UPS 400V which allow ultra fast capacity recovery and maintain water flow in case of power supply 1 failure	0400-2100
Dual Power Supply 400V/230V	85B	Power supply separated in two feeds :Supply 1 (400V): Compressors, Fans, pumps & heaters / Supply 2 (230V): Control only	Chiller control can be connected to external UPS 230V which allow ultra-fast capacity with the chiller	0400-2100
Service set valve	92	Liquid line valve, evaporator suction line valve and compressor discharge line valve	Allow isolation of various refrigerant circuit components for simplified service and maintenance	0400-2100
HP VSD single-pump (variable speed)	116V	Single high-pressure water pump with variable speed drive (VSD), electronic water flow control, pressure transducers. Multiple possibilities of water flow control. (expansion tank not included)	Easy and fast installation (plug & play), significant pumping energy cost savings (up to two-thirds), tighter water flow control, improved system reliability	0400-2100
Bacnet over IP	149	Bi-directional high-speed communication using BACnet protocol over Ethernet network (IP)	Easy and high-speed connection by ethernet line to a building management system. Allows access to multiple unit parameters	0400-2100
Modbus over IP and RS485	149B	Bi-directional high-speed communication using Modbus protocol over Ethernet network (IP)	Easy and high-speed connection by ethernet line to a building management system. Allows access to multiple unit parameters	0400-2100
Remote pump control	152P	Additional hardwired control outputs/inputs for internal pumps management	Pumps control can be directly managed by customer BMS via hardwired connections. Pumps control by Modbus is also possible	0400-2100
Energy Management Module Plus	156+	Extra control board card for additional control outputs/inputs. See Energy Management Module option chapter	Extended remote control capabilities (Set-point reset, freeze protection, demande limit, capacity limitation, input contact for refrigerant leak detection)	0400-2100
Dual relief valves on 3-way valve	194	Three-way valve upstream of dual relief valves on the shell and tubes evaporator	Valve replacement and inspection facilitated without refrigerant loss. Comforms to European standard EN378/BGVD4	0400-2100
Compliance with Swiss regulations	197	Additional tests on the water heat exchangers: supply (additional of PED documents) supplementary certificates and test certifications	Conformance with Swiss regulations	
Capacity booster (Dedicated to Process Applications)	232	Compression load increase	Cooling capacity increase	0400-2100
Insulation of the evap. in/out refrigerant lines	256	Thermal insulation of the evaporator entering/ leaving refrigerant lines with flexible, UV resistant insulation	Prevents condensation on the evaporator entering/leaving refrigerant lines	0400-2100
Anti-corrosion protection on Total FreeCooling coils	262AC	Same anti-corrosion treatment as for condenser MCHE coils	Improved corrosion resistance, recommended for use in moderately corrosive environments	0400-2100
Enviro-Shield anti-corrosion protection	262	Coating by conversion process which modifies the surface of the aluminum producing a coating that is integral to the coil. Complete immersion in a bath to ensure 100% coverage. Minimal heat transfer variation, tested 4000 hours salt spray per ASTM B117	Improved corrosion resistance, recommended for use in moderately corrosive environments	0400-2100

## OPTIONS

Option	N°	Description	Advantage	Use 30XF
Super Enviro-Shield anti-corrosion protection	263	Extremely durable and flexible epoxy polymer coating applied on micro channel heat exchangers by electro coating process, final UV protective topcoat. Minimal heat transfer variation, tested 6000 hours constant neutral salt spray per ASTM B117, superior impact resistance per ASTM D2794	Improved corrosion resistance, recommended for use in extremely corrosive environments	0400-2100
Super Enviro-Shield on Total Free Cooling coils	263AC	Same anti-corrosion treatment as for condenser MCHE coils	Improved corrosion resistance, recommended for use in extremely corrosive environments	0400-2100
Welded evaporator connection (kit)	266	Victaulic piping connections with welded joints	Easy installation	0400-2100
230V electrical plug	284	230V AC power supply source provided with plug socket and transformer (180 VA, 0,8 Amps)	Permits connection of a laptop or an electrical device during unit commissioning or servicing	0400-2100
Electric energy meter	294	Electricity meter. Display of energy consumption, instantaneous (U, V, I) and cumulated (kWh) on the unit user interface datas available on communication bus	Permits the acquisition, (remote) monitoring of energy used. Maximum limit power/intensity can be set up with this option.	0400-2100
Ultra Fast Capacity Recovery	295+	Electrical capacity module to enable quick restart and fast loading preserving unit reliability	Ultra Fast full capacity recovery after power failure. Matches requirements of typical critical missions applications. (process, data centers)	0400-2100
Mexico screw compressor	297	Screw compressor made in Mexico	Mexico screw compressor	0400-2100
Total hydraulic Free-Cooling	305A	Hydronic free-cooling coils on both refrigerant circuits.	Energy savings for applications with cooling demand throughout the entire year ( e.g. Industrial process, Data-center....)	0400-2100
Total hydraulic Free-Cooling Glycol Free	305C	Hydronic free-cooling coils on both refrigerant circuits and decoupling exchanger.	Energy savings for applications with cooling demand throughout the entire year ( e.g. Industrial process, Data-center....) Operation without glycol	0400-2100
Compliance with UAE regulation	318	Additional label on the unit with rated power input, rated current and EER following AHRI 550/590	Compliance with ESMA standard UAE.S 5010-5:2019.	0400-2100
Compliance with Qatar regulation	319	Specific nameplate on the unit with power supply 415 V+/-6%	Compliance with KAHRAMAA regulation in Qatar.	0400-2100
Compliance with Morocco regulation	327	Specifics documents according Morocco regulation	Conformance with Morocco regulations	0400-2100
Compressor with permanent magnet	329	Screw compressor equipped with permanent magnet motor	Permanent magnet motor improves significantly compressor efficiency	0400-2100
Delivery with plastic tarp cover	331	Plastic sheeting covering the units, with strapping securing it on the wooden pallet.	Allow unit to avoid dust and dirt from the outside environment during stocking and shipping.	0400-2100
400-3-60Hz power supply	335	400-3-60Hz power supply	Permits unit connection to 400-3-60Hz power supply	0400-2100
Active Harmonic Filters	336	Use of active electronic filters placed into electrical cabinet (THDI 5% at full load)	No energy lost in the distribution system and higher Power Usage Effectiveness of data center to maintain low and safe level of harmonics to ensure reliability. Maximum limit power/intensity can be set up with this option.	0400-2100
Surge arrester	337	Surge arrester Class I/II according to IEC 61643-11	To protect electrical devices from high voltage spikes. Can be recommended in area with high flashes / km <sup>2</sup> / year.	0400-2100
Hydraulic Free-cooling removal	338	Hydraulic free-cooling features will not be included in the unit	Cost reduction when Free cooling features can't be valorized	0400-2100





## WATER-COOLED AND CONDENSERLESS LIQUID CHILLERS WATER-SOURCED HEAT PUMPS



30WG optimized for cooling  
Compact design  
Plug and play approach  
High efficiency

## 30WG/30WGA-A

Nominal cooling capacity 25-190 kW

The 30WG/30WGA units are new Carrier chillers and heat pumps designed for commercial (offices, small hotels, leisure facilities), residential and industrial applications. All units offer a unique combination of high performance and functionality in an exceptionally compact chassis.

The 30WG, also available as a condenserless version (30WGA), is designed for air-conditioning applications with a high SEER value. As they can produce chilled water down to -12 °C they are also suitable for process applications.

A large number of options is available for the whole range:

- hydraulic modules with or without variable water flow rate,
- reinforced sound insulation,
- stacking and connection of two units
- low-temperature applications down to -12 °C (30WG only).



CARRIER participates in the ECP programme for LCP-HP  
Check ongoing validity of certificate:  
[www.eurovent-certification.com](http://www.eurovent-certification.com)

## CUSTOMER BENEFITS

### Features

- Reduced footprint
- Scroll compressors and R-410A refrigerant
- Variable-flow pump
- Low-noise option (-3 dB(A))
- Stacking of two units for increased capacity (up to size 090)
- Several communication protocols available: JBus, BacNet, MS/TP, LON
- Water connection at the top or rear (30WG only)

### Available versions

#### 30WG - optimised for air conditioning and process Heating & Cooling

- Evaporator temperature down to -12 °C
- Condenser temperature up to +60 °C
- Condensing pressure control devices available

#### 30WGA - optimised for air conditioning

- Continuous operation up to 62 °C saturated condensing temperature
- Compatible remote condensers available
- Optimised remote condenser fan control

### The right unit for any application

- Option 153 "Built-in DHW and space heating control" allows control of both domestic hot water and space heating requirements:
  - Domestic hot water production: a built-in three-way valve is directed to divert the heat flow from the space heating loop to the domestic hot water loop and vice versa.
  - Space heating control: the setpoint is adjustable, based on the daily schedule or the outside air temperature (weather compensation function).
  - Control of auxiliary systems: if an alarm is detected at the 30WG or if there is insufficient heating capacity, a digital signal starts an auxiliary electric heater (1 to 4 stages) or boiler.
  - Pump control: allows control of the built-in pump as well as the pump in the secondary loop (to terminals).
- In 30WG units the pressure control signal ensures safe unit operation and maximised performance at low source-side water temperatures.

- The condenserless 30WGA units are ideal for refurbishment projects where a remote condenser exists on site, and for all projects without geothermal/natural sinks for heat rejection.
- In 30WG units the Heating System Manager (HSM) accessory allows control of systems with several heat sources and different additional systems: electric heat, boiler or for the most complex systems district heating (see pages 9 to 11).

### Adaptability and simple installation

- The 30WG units can be provided with several hydraulic module options, both on the evaporator and/or condenser side, with different levels of available pressure and variable or fixed-speed pumps (see page 7).
- If option 153 is selected domestic hot water production is controlled via a built-in three-way diverter valve (not supplied).
- 30WG units offer water-side cooling/heating reversibility.
- Remote condenser fan control possible for 30WGA units.

### Water connections at the rear of the unit



## CUSTOMER BENEFITS

**Internal view of 30WG 170**



**Component accessibility**

See photos below.

**Access to scroll compressors**



**Water connections at the top of the unit**



**Access to control panel**



### A compact high-performance product range

- Small footprint, ideal for refurbished buildings, allows access in very tight plant rooms.
- 30WG: High SEER and SEPR
- Units optimized for process and comfort applications.
- The 30WGA is based on the 30WG design to ensure efficient operation for applications with remote air-cooled condensers.
- Variable-flow pumps reduce system energy consumption.
- The entire range offers low sound levels, allowing installation in any building type. The low-noise option ensures enhanced acoustic comfort (-3 dB(A)).
- 30WG/30WGA units are equipped with the latest generation R410A scroll compressor, optimised for typical operating conditions for water-sourced units.

### Two-unit stacking option for reduced footprint size 020-090

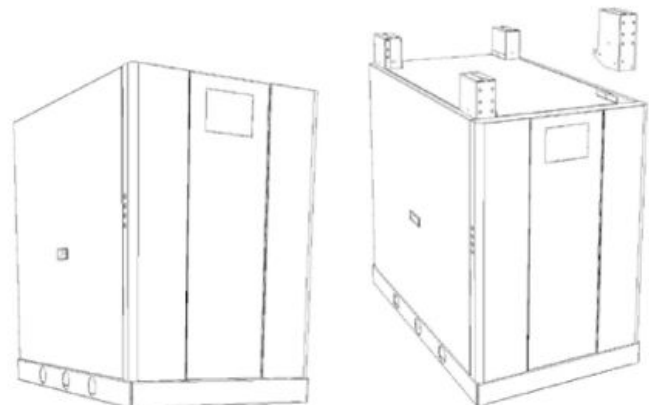

## CUSTOMER BENEFITS

### SmartVu™ control

The SmartVu™ control combines intelligence with operating simplicity. The control constantly monitors all machine parameters and precisely manages the operation of compressors, expansion devices, fans and the evaporator water pump for optimum energy efficiency.

The SmartVu™ control features advanced communication technology over Ethernet (IP) and a user-friendly and intuitive user interface with 4.3-inch colour touch screen.

- Energy management configuration
  - Internal timer: controls chiller on/off times and operation at a second setpoint
  - Setpoint offset based on the outdoor air temperature
  - Master/slave control of two chillers operating in parallel with runtime balancing and automatic changeover in case of a unit fault.
  - Innovative smart energy monitoring, providing users with smart data such as real-time electrical energy consumption and cooling capacity, and instantaneous and average energy efficiency values.
  - For further energy savings, the AquaSnap® can be monitored remotely by Carrier experts for energy consumption diagnosis and optimisation.
- Integrated features
  - Night mode: Capacity and fan speed limitation for reduced noise level
  - With hydraulic module: Water pressure display and water flow rate calculation.
- Advanced communication features
  - Easy and high-speed communication technology over Ethernet (IP) to a centralised building management system
  - Access to multiple unit parameters.
- Maintenance functions
  - F-Gas regulation leak check reminder alert
  - Maintenance alert can be configured to days, months or hours of operation
  - Display of trend curves for the main values
  - Management of a fault memory allowing a log of the last 50 incidents to be accessed, with operating readings taken when the fault occurs
  - Blackbox memory

- 4"3 SmartVu™ user interface



- Intuitive and user-friendly 4"3 inch touch screen interface
- Concise and clear information is available in local languages
- Complete menu, customised for different users (end user, service personnel or Carrier engineers).

### Remote management (standard)

Units with SmartVu™ control can be easily accessed from the internet, using a PC with an Ethernet connection. This makes remote control quick and easy and offers significant advantages for service operations.

The AquaSnap® is equipped with an RS485 serial port that offers multiple remote control, monitoring and diagnostic possibilities. Carrier offers a vast choice of control products, specially designed to control, manage and supervise the operation of an air conditioning system. Please consult your Carrier representative for more information.

The AquaSnap® also communicates with other centralised building management systems via optional communication gateways.

A connection terminal allows the AquaSnap® unit to be remotely controlled by wire:

- Start/stop: Opening of this contact will shut down the unit
- Dual setpoint: closing of this contact activates a second setpoint (e.g.: unoccupied mode).
- Demand limit: Closing of this contact limits the maximum chiller capacity to a predefined value.
- Operation indication: This volt-free contact indicates that the chiller is operating (cooling load).
- Alarm indication: this volt-free contact indicates the presence of a major fault that has led to the shut-down of one or several refrigerant circuits.



## CUSTOMER BENEFITS

### 30WG/30WGA units compatible the Carrier 09 series dry coolers/remote condensers

The Carrier 09 series dry coolers and remote condensers are compatible with the 30WG and 30WGA units.

The chiller 30WG/30WGA can control the fans of the dry cooler / remote condenser via digital or analogue outputs (according to AC or EC motors) with following options :

- For chiller 30WG/30WGA : option 154
- For dry cooler / remote condenser : dedicated control cabinet with an auxiliary board.

A simple communication bus is required between the chiller and the dry cooler/ remote condenser.

As all control components are installed and tested in the factory, installation and start-up of the unit and its associated dry cooler/remote condenser are simplified.

Control board algorithms optimise energy consumption based on:

- the outside temperature and chilled-water temperature read for dry coolers
- the outside temperature and saturated refrigerant discharge temperature read for remote condensers.

A simple communication bus is required downstream to connect the control board to the unit control.

### 30WG system concept

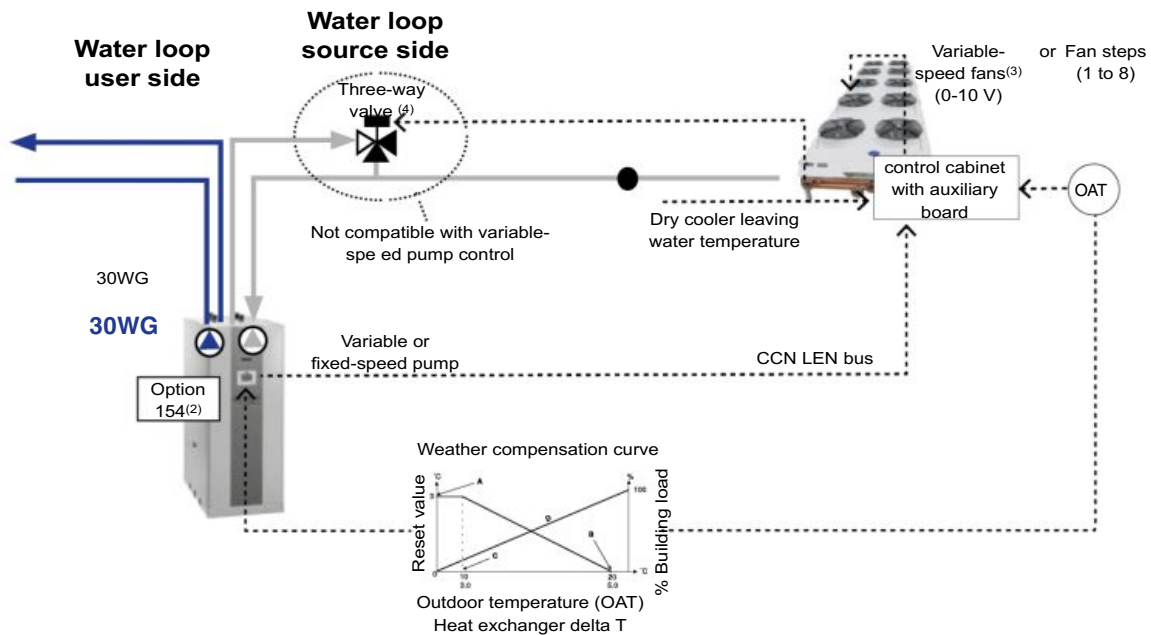

#### Legend

- CCN** Carrier Comfort Network
- LEN** Local equipment network
- OAT** Outside air temperature
- (1) Control board option on 09PE dedicated to 30WG
- (2) Option 154 for connection and communication with 09PE Dry cooler
- (3) For correct operation of the unit below 0 °C variable speed fans are required.
- (4) Three-Way valve or two two-way valves optional on 09PE

CUSTOMER BENEFITS

30WGA system concept

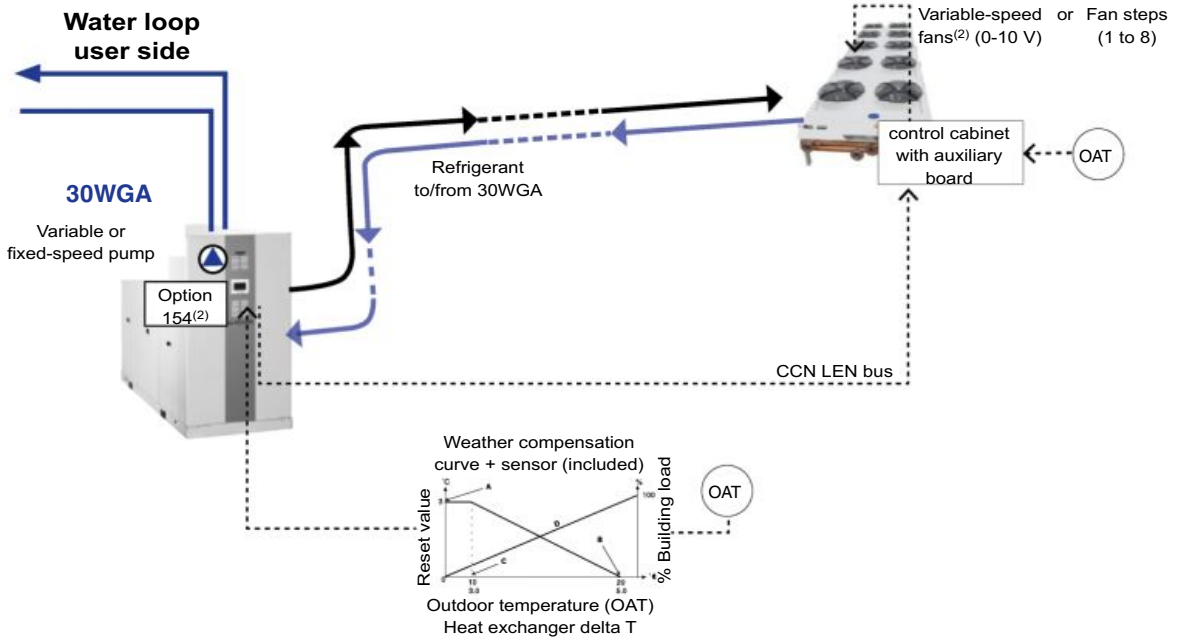

Legend

- CCN** Carrier Comfort Network
- LEN** Local equipment network
- OAT** Outside air temperature
- (1) Control board option on 09PE dedicated to 30WG
- (2) Option 154 for connection and communication with 09PE Dry cooler
- (3) For correct operation of the unit below 0 °C variable-speed fans are required.

## OPTIONS

Options	No.	Description	Advantages	Use
Medium-temperature brine solution	5B	Low temperature chilled water production down to 0°C with ethylene glycol and propylene glycol.	Covers specific applications such as ice storage and industrial processes	30WGA 020-190
Low-temperature brine solution	6B	Low temperature glycol solution production down to -12 °C with ethylene glycol	Covers specific applications such as ice storage and industrial processes	30WG 020-190
Soft Starter	25	Electronic starter on each compressor	Reduced start-up current	30WG 020-190 30WGA 020-190
Master/slave operation	58	Unit equipped with supplementary water outlet temperature sensor kit to be field-installed allowing master/slave operation of two units connected in parallel	Optimised operation of two units connected in parrallele operation with operating time equalisation	30WG 020-190 30WGA 020-190
External disconnect handle	70F	The handle of the electrical disconnect switch is on the outside of the unit	Quick access to the unit disconnect switch	30WG 020-190 30WGA 020-190
Evap. single pump power/control circuit	84	Unit equipped with an electrical power and control circuit for one pump evaporator side	Quick and easy installation: the control of fixed speed pumps is embedded in the unit control	30WG 110-190
Cond. single pump power/control circuit	84R	Unit equipped with an electrical power and control circuit for one pump condenser side	Quick and easy installation: the control of fixed speed pumps is embedded in the unit control	30WG 110-190
Condenser insulation	86	Thermal condenser insulation	Minimizes thermal dispersions condenser side (key option for heat pump or heat recovery applications) and allows compliancy with special installation criteria (hot parts insulated)	30WG 020-190
HP single-pump hydraulic module	116R	Single high-pressure water pump, water filter, electronic water flow control, pressure transducers. For more details, refer to the dedicated chapter (expansion tank not included.Option with built-in safety hydraulic components available.)	Easy and fast installation (plug & play)	30WG 110-190 30WGA 110-190
LP evap. single-pump	116T	Evaporator hydraulic module equipped with low pressure fixed-speed pump, drain valve, air vent and pressure sensors. For more details, refer to the dedicated chapter (expansion tank not included.Option with built-in safety hydraulic components available.)	Easy and fast installation (plug & play)	30WG 020-190 30WGA 020-190
HP evap. variable-speed single-pump	116V	Evaporator hydraulic module equipped with high-pressure variable-speed pump, drain valve, air vent and pressure sensors. For more details, refer to the dedicated chapter (expansion tank not included.Option with built-in safety hydraulic components available.)	Easy and fast installation (plug & play), significant pumping energy cost savings (more than two-thirds), tighter water flow control, improved sytem reliability	30WG 020-190 30WGA 020-190
HP VSD dual-pump hydraulic mod.	116W	Dual high-pressure water pump with variable speed drive (VSD), pressure transducers. Multiple possibilities of water flow control. For more details, refer to the dedicated chapter (expansion tank not included Option with built-in safety hydraulic components available)	Easy and fast installation (plug & play), significant pumping energy cost savings (more than two-thirds), tighter water flow control, improved sytem reliability	30WG 110-190 30WGA 110-190
LP VSD single-pump	116Y	Evaporator hydraulic module equipped with low -pressure variable-speed pump, drain valve, air vent and pressure sensors. For more details, refer to the dedicated chapter (expansion tank not included.Option with built-in safety hydraulic components available.)	Easy and fast installation (plug & play), significant pumping energy cost savings (more than two-thirds), tighter water flow control, improved sytem reliability	30WG 110-190 30WGA 110-190
Lon gateway	148D	Two-directional communication board complying with Lon Talk protocol	Connects the unit by communication bus to a building management system	30WG 020-190 30WGA 020-190
Bacnet over IP	149	Two-directional high-speed communication using BACnet protocol over Ethernet network (IP)	Easy and high-speed connection by ethernet line to a building management system. Allows access to multiple unit parameters	30WG 20-190 30WGA 020-190
Modbus over IP and RS485	149B	Bi-directional high-speed communication using Modbus protocol over Ethernet network (IP)	Easy and high-speed connection by ethernet line to a building management system. Allows access to multiple unit parameters	30WG 020-190 30WGA 020-190

## OPTIONS

Options	No.	Description	Advantages	Use
Built-in DHW & space heating control	153	Control board factory-installed on the unit, control using weather compensation, control of supplementary electric heater (4 stages) or boiler, needle valve for domestic hot-water production with programmable time schedule.	Permits easy control of a basic heating system	30WG 020-190
Specific dry cooler control	154	Dedicated connection and software for 09PE dry cooler management. For 09PE dry cooler need to select the option control cabinet manage by the chiller	Permits the use of an energy-efficient plug-and-play system	30WG 020-190
Condenser control	154	Control box for communication with the condenser via a bus. For OPERA condenser need to select the cabinet with option control cabinet manage by the chiller Connect'Touch control	Permits the use of an energy-efficient plug-and-play system	30WGA 020-190
Compliance with Russian regulations	199	EAC certification	Conformance with Russian regulations	30WG 020-190 30WGA 020-190
Insulation of the evap. in/out ref.lines	256	Thermal insulation of the evaporator entering/leaving refrigerant lines with flexible, anti-UV insulant	Prevents condensation on the evaporator entering/leaving refrigerant lines	30WG 020-190 30WGA 020-190
Low noise level	257	Compressor sound enclosure	Reduced sound emissions	30WG 020-190 30WGA 020-190
Very low sound level	258	Enhanced sound insulation of main noise sources (Material classified CD0S2 fire class according to Euroclass 13-501).	6 dB(A) quieter than standard . Refer to the physical data table for detailed values	30WG 020-090 30WGA 020-090
Evaporator screw connection sleeves kit	264	Evaporator inlet/outlet screw connection sleeves	Allows unit connection to a screw connector	30WG 020-140 30WGA 020-140
Condenser screw connection sleeves kit	265	Condenser inlet/outlet screw connection sleeves	Allows unit connection to a screw connector	30WG 020-140
Welded evaporator connection kit	266	Victaulic piping connections with welded joints	Easy installation	30WG 020-190 30WGA 020-190
Welded condenser water connection kit	267	Victaulic piping connections with welded joints	Easy installation	30WG 020-190
HP single-pump, cond. side	270R	Condenser hydraulic module equipped with high pressure fixed-speed pump, drain valve, air vent and pressure sensors. Built-in safety hydraulic components available in option.	Easy and fast installation (plug & play)	30WG 110-190
LP single-pump, cond. side	270T	Condenser hydraulic module equipped with low pressure fixed-speed pump, drain valve, air vent and pressure sensors. Built-in safety hydraulic components available in option.	Easy and fast installation (plug & play)	30WG 020-190
HP cond. variable-speed single-pump	270V	Condenser hydraulic module equipped with high-pressure variable-speed pump, drain valve, air vent and pressure sensors. (expansion tank not included) Built-in safety hydraulic components available in option.	Easy and fast installation (plug & play), reduced power consumption of the water circulation pump	30WG 020-190
HP cond. variable-speed dual-pump	270W	Condenser hydraulic module equipped with dual high-pressure variable-speed pump, drain valve, air vent and pressure sensors. (expansion tank not included) Built-in safety hydraulic components available in option.	Easy and fast installation (plug & play), reduced power consumption of the water circulation pump	30WG 110-190
LP cond. variable-speed single-pump	270Y	Condenser hydraulic module equipped with low-pressure variable-speed pump, drain valve, air vent and pressure sensors. (expansion tank not included) Built-in safety hydraulic components available in option.	Easy and fast installation (plug & play), reduced power consumption of the water circulation pump	30WG 110-190
Unit stackable for operation	273	Unit stackable for operation	Reduced footprint size	30WG 020-090 30WGA 020-090

## OPTIONS

Options	No.	Description	Advantages	Use
water connection at the top	274	Customer water connection at the top of the unit	Reduced footprint size	30WG 020-190 30WGA 020-190
Replaceable filter drier	277	Filter drier with cartridge to replace hermetic filter	Easy filter replacement without emptying the refrigerant circuit	30WGA 020-190
Safety hydraulic components, evap. side	293	Screen filter, expansion tank and relief valve integrated in the evaporator hydraulic module	Easy and fast installation (plug & play), operating safety	30WG 020-190 30WGA 020-190
Safety hydraulic components, cond. side	293A	Screen filter, expansion tank and relief valve integrated in the condenser hydraulic module	Easy and fast installation (plug & play), operating safety	30WG 020-190
Set point adjustment by 4-20mA signal	311	Connections to allow a 4-20mA signal input	Easy energy management, allow to adjust set point by a 4-20mA external signal	30WG 020-190 30WGA 020-190
External temperature sensor	312	External temperature sensor control for using weather compensation	Allow to adjust set point using weather compensation and define autorisation operation mode to external temperature	30WG 020-190 30WGA 020-190
Free Cooling dry cooler management	313	Control & connections to a Free Cooling Dry cooler 09PE or 09VE fitted with option FC control box	Easy system management, Extended control capabilities to a dry cooler used in Free Cooling mode	30WG 020-190 30WGA 020-190



PHYSICAL DATA, 30WG UNITS , SIZES 020 TO 090

30WG			020	025	030	035	040	045	050	060	070	080	090	
<b>Heating</b>														
<b>Standard unit Full load performances*</b>	HW1	Nominal capacity	kW	30	35	38	44	50	56	70	77	89	101	114
		COP	kW/kW	5,53	5,53	5,49	5,52	5,49	5,51	5,58	5,48	5,53	5,46	5,50
	HW2	Nominal capacity	kW	29	33	36	43	49	54	68	74	85	97	108
		COP	kW/kW	4,34	4,37	4,35	4,36	4,40	4,35	4,39	4,35	4,32	4,40	4,32
	HW3	Nominal capacity	kW	28	33	35	41	47	52	65	73	81	93	103
		COP	kW/kW	3,59	3,63	3,61	3,60	3,67	3,61	3,58	3,62	3,54	3,70	3,56
<b>Standard unit Seasonal energy efficiency**</b>	HW1	SCOP <sub>30/35°C</sub>	kW/kW	5,46	5,45	5,36	5,40	5,35	5,38	6,12	6,08	6,09	6,11	6,09
		ηs heat <sub>30/35°C</sub>	%	211	210	206	208	206	207	237	235	235	236	235
	HW3	<b>SCOP<sub>47/55°C</sub></b>	<b>kW/kW</b>	<b>4,36</b>	<b>4,37</b>	<b>4,34</b>	<b>4,37</b>	<b>4,40</b>	<b>4,34</b>	<b>4,91</b>	<b>4,96</b>	<b>4,85</b>	<b>5,08</b>	<b>4,91</b>
		<b>ηs heat<sub>47/55°C</sub></b>	<b>%</b>	<b>167</b>	<b>167</b>	<b>166</b>	<b>167</b>	<b>168</b>	<b>166</b>	<b>188</b>	<b>190</b>	<b>186</b>	<b>195</b>	<b>188</b>
		P <sub>rated</sub>	kW	32	37	40	47	54	59	75	83	93	106	118
		Energy labelling		A++	A++	A++	A++	A++	A++	-	-	-	-	-
<b>Cooling</b>														
<b>Standard unit Full load performances*</b>	CW1	Nominal capacity	kW	25	29	32	37	42	47	58	63	74	84	95
		EER	kW/kW	4,72	4,72	4,69	4,73	4,69	4,72	4,72	4,65	4,69	4,65	4,68
		Eurovent class		B	B	B	B	B	B	B	B	B	B	B
	CW2	Nominal capacity	kW	34	39	43	50	57	66	79	86	102	113	129
		EER	kW/kW	6,42	6,10	6,03	6,04	5,90	6,06	6,12	5,95	6,19	5,93	6,13
		Eurovent class		A	A	A	A	A	A	A	A	A	A	A
<b>Standard unit Seasonal energy efficiency**</b>	CW1	SEER <sub>12/7°C</sub> Comfort low temp.	kW/kW	4,94	4,94	4,83	4,87	4,85	4,88	5,70	5,62	5,58	5,72	5,68
		SEPR <sub>12/7°C</sub> Process high temp.	kW/kW	6,42	6,44	6,26	6,22	6,26	6,31	6,63	6,50	6,48	6,59	6,62
<b>Unit with option 6B Seasonal energy efficiency**</b>	CW2	SEPR <sub>-2/-8°C</sub> Process medium temp.***	kWh/kWh	3,92	4,26	4,43	4,34	4,47	4,01	4,12	4,73	4,55	4,78	4,76
<b>Integrated part load value</b>	IPLV.SI		kW/kW	5,840	5,850	5,760	5,780	5,770	5,820	6,580	6,680	6,560	6,810	6,720
<b>Operating weight<sup>(1)</sup></b>			kg	191	200	200	207	212	220	386	392	403	413	441
<b>Operating weight with option 258<sup>(1)</sup></b>			kg	198	207	207	214	219	227	399	405	416	426	454
<b>Sound levels<sup>(2)</sup></b>														
		Sound power level, standard unit	dB(A)	67	68	69	69	70	70	72	72	72	73	73
		Sound power level, option 257	dB(A)	65	66	66	67	68	68	68	69	69	69	70
		Sound power level, option 258	dB(A)	61	62	63	63	64	64	66	66	66	67	67
		Sound power level, option 257 + 258	dB(A)	60	62	62	62	64	63	65	65	65	66	66
<b>Dimensions, standard unit<sup>(3)</sup></b>														
		Width	mm	600	600	600	600	600	600	880	880	880	880	880
		Length	mm	1044	1044	1044	1044	1044	1044	1474	1474	1474	1474	1474
		Height	mm	901	901	901	901	901	901	901	901	901	901	901

\* In accordance with standard EN14511-3:2022  
 \*\* In accordance with standard EN14825:2022, average climate  
 \*\*\* With EG 30%  
 HW1 Heating mode conditions: Evaporator entering/leaving water temperature 10°C/7°C, condenser entering/leaving water temperature 30°C/35°C, evaporator and condenser fouling factor 0 m2. k/W  
 HW2 Heating mode conditions: Evaporator entering/leaving water temperature 10°C/7°C, condenser entering/leaving water temperature 40°C/45°C, evaporator and condenser fouling factor 0 m2. k/W  
 HW3 Heating mode conditions: Evaporator entering/leaving water temperature 10°C/7°C, condenser entering/leaving water temperature 47°C/55°C, evaporator and condenser fouling factor 0 m2. k/W  
 CW1 Cooling mode conditions: Evaporator water entering/leaving temperature 12°C/7°C, condenser entering/leaving water temperature 30°C/35°C, evaporator and condenser fouling factor 0 m2.K/W  
 CW2 Cooling mode conditions: Evaporator water entering/leaving temperature 23°C/18°C, condenser entering/leaving water temperature 30°C/35°C, evaporator and condenser fouling factor 0 m2.K/W  
 ηs heat<sub>30/35°C</sub>& SCOP<sub>30/35°C</sub> Values calculated in accordance with EN14825:2022  
**ηs heat<sub>47/55°C</sub> & SCOP<sub>47/55°C</sub>** **Bold values compliant to Ecodesign regulation: (EU) No 813/2013 for Heat Pump application**  
 SEER<sub>12/7°C</sub> & SEPR<sub>12/7°C</sub> Values calculated in accordance with EN14825:2022  
 SEPR<sub>-2/-8°C</sub> Values calculated in accordance with EN14825:2022  
 - Not applicable  
 IPLV.SI Calculations according to standard performances AHRI 551-591 (SI)  
 (1) Weight shown is a guideline only. Please refer to the unit nameplate  
 (2) In dB ref=10<sup>-12</sup> W, (A) weighting. Declared dualnumber noise emission values in accordance with ISO 4871 (with an associated uncertainty of +/-3dB(A)). Measured in accordance with ISO 9614-1.  
 (3) The dimensions shown are for the standard unit. For other unit types please refer to the dimensional drawings.



Eurovent certified values

## PHYSICAL DATA, 30WG UNITS , SIZES 020 TO 090

30WG	020	025	030	035	040	045	050	060	070	080	090	
<b>Compressors</b>	Hermetic scroll 48.3 r/s											
Quantity	1	1	1	1	1	1	2	2	2	2	2	
Number of capacity stages	1	1	1	1	1	1	2	2	2	2	2	
Minimum capacity	%	100	100	100	100	100	100	50	50	50	50	
<b>Refrigerant<sup>(1)</sup></b>	R410A (GWP=2088 Following ARI4)											
Charge, standard unit	kg	3,5	3,5	3,6	3,7	4,0	4,6	7,6	7,8	7,9	8,7	11,5
	teqCO <sub>2</sub>	7,2	7,3	7,4	7,6	8,2	9,5	15,9	16,3	16,5	18,2	24
<b>Capacity control</b>	SmartVu™											
<b>Evaporator</b>	Direct-expansion plate heat exchanger											
Water volume	l	3,3	3,6	3,6	4,2	4,6	5,0	8,4	9,2	9,6	10,4	12,5
Water connections	Victaulic											
Inlet/outlet	in	1,5	1,5	1,5	1,5	1,5	1,5	2	2	2	2	2
Max. water-side operating pressure without hydraulic module	kPa	1000	1000	1000	1000	1000	1000	1000	1000	1000	1000	1000
<b>Condenser</b>	Plate heat exchanger											
Net water volume	l	3,3	3,6	3,6	4,2	4,6	5,0	8,4	9,2	9,6	10,4	12,5
Water connections	Victaulic											
Inlet/outlet	in	1,5	1,5	1,5	1,5	1,5	1,5	2	2	2	2	2
Max. water-side operating pressure without hydraulic module	kPa	1000	1000	1000	1000	1000	1000	1000	1000	1000	1000	1000
<b>Chassis paint color</b>	Color code: RAL7035											

(1) Weight shown is a guideline only. Please refer to the unit nameplate

PHYSICAL DATA, 30WG UNITS, SIZES 110 TO 190

30WG			110	120	140	150	170	190	
<b>Heating</b>									
<b>Standard unit</b> Full load performances*	HW1	Nominal capacity	kW	135	152	175	183	207	238
		COP	kW/kW	5,50	5,50	5,42	5,58	5,59	5,50
	HW2	Nominal capacity	kW	131	148	163	174	197	218
		COP	kW/kW	4,44	4,45	4,38	4,41	4,50	4,38
	HW3	Nominal capacity	kW	125	140	160	166	187	214
		COP	kW/kW	3,56	3,45	3,54	3,55	3,44	3,53
<b>Standard unit</b> Seasonal energy efficiency**	HW1	SCOP <sub>30/35°C</sub>	kW/kW	6,31	6,37	6,31	6,31	6,32	6,18
		η <sub>s heat</sub> <sub>30/35°C</sub>	%	244	247	244	244	245	239
	HW3	<b>SCOP<sub>47/55°C</sub></b>	<b>kW/kW</b>	<b>5,05</b>	<b>5,09</b>	<b>5,05</b>	<b>5,02</b>	<b>5,17</b>	<b>4,96</b>
		<b>η<sub>s heat</sub><sub>47/55°C</sub></b>	<b>%</b>	<b>194</b>	<b>196</b>	<b>194</b>	<b>193</b>	<b>199</b>	<b>190</b>
		P <sub>rated</sub>	kW	143	161	178	191	216	239
	<b>Cooling</b>								
<b>Standard unit</b> Full load performances*	CW1	Nominal capacity	kW	115	130	144	153	172	192
		EER	kW/kW	4,79	4,77	4,70	4,83	4,78	4,79
		Eurovent class		B	B	B	B	B	B
	CW2	Nominal capacity	kW	155	176	196	207	231	262
		EER	kW/kW	6,20	6,10	6,01	6,23	5,97	6,14
		Eurovent class		A	A	A	A	A	A
<b>Standard unit</b> Seasonal energy efficiency**		SEER <sub>12/7°C</sub> Comfort low temp.	kW/kW	6,12	6,24	6,17	5,97	6,06	5,96
		SEPR <sub>12/7°C</sub> Process high temp.	kWh/kWh	6,98	7,13	6,90	6,54	6,62	6,41
<b>Unit with option 6B</b> Seasonal energy efficiency**		SEPR <sub>2/-8°C</sub> Process medium temp.***	kWh/kWh	4,01	4,40	4,35	4,52	4,65	4,45
<b>Integrated part load value</b>		IPLV.SI	kW/kW	6,860	6,980	6,900	6,820	6,890	6,820
<b>Operating weight (1)</b>			kg	707	733	758	841	877	908
<b>Sound levels (2)</b>									
		Sound power level, standard unit	dB(A)	76	77	78	76	77	78
		Sound power level, option 257	dB(A)	73	74	75	73	74	75
<b>Dimensions, standard unit (3)</b>									
		Width	mm	880	880	880	880	880	880
		Length	mm	1583	1583	1583	1583	1583	1583
		Height	mm	1574	1574	1574	1574	1574	1574
<b>Compressors</b>									
				Hermetic scroll 48.3 r/s					
		Quantity		3	3	3	4	4	4
		Number of capacity stages		3	3	3	4	4	4
		Minimum capacity	%	33	33	33	25	25	25

\* In accordance with standard EN14511-3:2022  
 \*\* In accordance with standard EN14825:2022, average climate  
 \*\*\* With EG 30%  
 HW1 Heating mode conditions: Evaporator entering/leaving water temperature 10°C/7°C, condenser entering/leaving water temperature 30°C/35°C, evaporator and condenser fouling factor 0 m2. kW  
 HW2 Heating mode conditions: Evaporator entering/leaving water temperature 10°C/7°C, condenser entering/leaving water temperature 40°C/45°C, evaporator and condenser fouling factor 0 m2. kW  
 HW3 Heating mode conditions: Evaporator entering/leaving water temperature 10°C/7°C, condenser entering/leaving water temperature 47°C/55°C, evaporator and condenser fouling factor 0 m2. kW  
 CW1 Cooling mode conditions: Evaporator water entering/leaving water temperature 12°C/7°C, condenser entering/leaving water temperature 30°C/35°C, evaporator and condenser fouling factor 0 m2.K/W  
 CW2 Cooling mode conditions: Evaporator water entering/leaving water temperature 23°C/18°C, condenser entering/leaving water temperature 30°C/35°C, evaporator and condenser fouling factor 0 m2.K/W  
 η<sub>s heat</sub><sub>30/35°C</sub> & SCOP<sub>30/35°C</sub> Values calculated in accordance with EN14825:2022  
 η<sub>s heat</sub><sub>47/55°C</sub> & SCOP<sub>47/55°C</sub> **Bold values compliant to Ecodesign regulation: (EU) No 813/2013 for Heat Pump application**  
 SEER<sub>12/7°C</sub> & SEPR<sub>12/7°C</sub> Values calculated in accordance with EN14825:2022  
 SEPR<sub>2/-8°C</sub> Values calculated in accordance with EN14825:2022  
 IPLV.SI Calculations according to standard performances AHRI 551-591 (SI).  
 (1) Weight shown is a guideline only. Please refer to the unit nameplate  
 (2) In dB ref=10<sup>-12</sup> W, (A) weighting. Declared dualnumber noise emission values in accordance with ISO 4871 (with an associated uncertainty of +/-3dB(A)). Measured in accordance with ISO 9614-1.  
 (3) The dimensions shown are for the standard unit. For other unit types please refer to the dimensional drawings.



Eurovent certified values

## PHYSICAL DATA, 30WG UNITS, SIZES 110 TO 190

30WG		110	120	140	150	170	190
<b>Refrigerant <sup>(1)</sup></b>		R410A (GWP=2088 Following ARI4)					
Charge, standard unit	kg	13,3	14,5	15,6	21,0	23,0	24,2
	teqCO <sub>2</sub>	27,8	30,3	32,6	43,8	48,0	50,5
<b>Capacity control</b>		SmartVu™					
<b>Evaporator</b>		Direct-expansion plate heat exchanger					
Water volume	l	15,18	17,35	19,04	23,16	26,52	29,05
Water connections	-	Victaulic					
Inlet/outlet	in	2 1/2	2 1/2	2 1/2	3	3	3
Max. water-side operating pressure without hydraulic module	kPa	1000	1000	1000	1000	1000	1000
<b>Condenser</b>		Plate heat exchanger					
Net water volume	l	15,18	17,35	19,04	23,16	26,52	29,05
Water connections	-	Victaulic					
Inlet/outlet	in	2 1/2	2 1/2	2 1/2	3	3	3
Max. water-side operating pressure without hydraulic module	kPa	1000	1000	1000	1000	1000	1000
<b>Chassis paint color</b>		Color code: RAL7035					

(1) Weight shown is a guideline only. Please refer to the unit nameplate

PHYSICAL DATA, 30WGA UNITS

30WGA			020	025	030	035	040	045	050	060	070	080	090	
<b>Standard unit</b> Full load performances*	CS1	Nominal capacity	kW	22,8	27	29,1	34	39,2	42,7	54,5	59,1	67,5	78,2	87,4
		EER	kW/kW	3,70	3,76	3,68	3,73	3,75	3,70	3,70	3,66	3,64	3,81	3,77
	CS2	Nominal capacity	kW	31,8	37,6	40,3	47	53,2	61,3	74,5	81,2	94,9	108	121
		EER	kW/kW	5,35	5,25	5,11	5,09	4,99	5,15	5,16	5,15	5,18	5,26	5,13
<b>Operating weight<sup>(1)</sup></b>			kg	164	171	171	177	180	185	321	324	332	339	354
<b>Operating weight with option 258<sup>(1)</sup></b>			kg	171	178	178	184	187	192	334	337	345	352	367
<b>Sound levels<sup>(2)</sup></b>														
Sound power level, standard unit			dB(A)	67	68	69	69	70	70	72	72	72	73	73
Sound power level, option 257			dB(A)	65	66	66	67	68	68	68	69	69	69	70
Sound power level, option 258			dB(A)	61	62	63	63	64	64	66	66	66	67	67
Sound power level, option 257 + 258			dB(A)	60	62	62	62	64	63	65	65	65	66	66
<b>Dimensions, standard unit<sup>(3)</sup></b>														
Width			mm	600	600	600	600	600	600	880	880	880	880	880
Length			mm	1044	1044	1044	1044	1044	1044	1474	1474	1474	1474	1474
Height			mm	901	901	901	901	901	901	901	901	901	901	901
<b>Compressors</b>				Hermetic scroll 48.3 r/s										
Circuit A				1	1	1	1	1	1	2	2	2	2	2
Circuit B				-	-	-	-	-	-	-	-	-	-	-
Number of capacity stages				1	1	1	1	1	1	2	2	2	2	2
Minimum capacity			%	100	100	100	100	100	100	50	50	50	50	50
<b>Refrigerant</b>				R410A (GWP=2088 Following ARI4)										
<b>Capacity control</b>				SmartVu™										
<b>Evaporator</b>				Direct-expansion plate heat exchanger										
Water volume			l	3,3	3,6	3,6	4,2	4,6	5,0	8,4	9,2	9,6	10,4	12,5
<b>Water connections</b>				Victaulic										
Inlet/outlet			in	1,5	1,5	1,5	1,5	1,5	1,5	2	2	2	2	2
Max. water-side operating pressure without hydraulic module			kPa	1000	1000	1000	1000	1000	1000	1000	1000	1000	1000	1000
<b>Refrigerant connections</b>														
Discharge line diameter			in	7/8	7/8	7/8	7/8	7/8	7/8	1-1/8	1-1/8	1-1/8	1-1/8	1-1/8
Liquid line diameter			in	5/8	5/8	5/8	5/8	5/8	5/8	7/8	7/8	7/8	7/8	7/8
Chassis paint color				Color code: RAL7035										

\* In accordance with standard EN14511-3:2022. Refrigerant piping equivalent length (without drier and valves) = 3 m.  
 CS1 Cooling mode conditions: evaporator entering/leaving water temperature 12 °C/7 °C, saturated condensing temperature 45 °C, subcooling 5 K, evaporator fouling factor 0 m<sup>2</sup>K/W.  
 CS2 Cooling mode conditions: evaporator entering/leaving water temperature 23 °C/18 °C, saturated condensing temperature 45 °C, subcooling 5 K, evaporator fouling factor 0 m<sup>2</sup>K/W.  
 (1) Weight shown is a guideline only. Please refer to the unit nameplate  
 (2) In dB ref=10<sup>-12</sup> W, (A) weighting. Declared dualnumber noise emission values in accordance with ISO 4871 (with an associated uncertainty of +/-3dB(A) Measured in accordance with ISO 9614-1.  
 (3) The dimensions shown are for the standard unit. For other unit types please refer to the dimensional drawings.



## PHYSICAL DATA, 30WGA UNITS

30WGA			110	120	140	150	170	190	
<b>Standard unit</b> Full load performances*	CS1	Nominal capacity	kW	106	119	132	140	159	175
		EER	kW/kW	3,78	3,78	3,72	3,75	3,81	3,72
	CS2	Nominal capacity	kW	146	166	185	195	218	247
		EER	kW/kW	5,24	5,17	5,12	5,32	5,17	5,26
<b>Operating weight<sup>(1)</sup></b>			kg	762	787	814	909	944	975
<b>Sound levels<sup>(2)</sup></b>									
Sound power level			dB(A)	76	77	78	76	77	78
Sound power level, option 257			dB(A)	73	74	75	73	74	75
<b>Dimensions, standard unit<sup>(3)</sup></b>									
Width			mm	880	880	880	880	880	880
Length			mm	1583	1583	1583	1583	1583	1583
Height			mm	1574	1574	1574	1574	1574	1574
<b>Compressors</b>				Hermetic scroll 48.3 r/s					
Circuit A				3	3	3	4	4	4
Number of capacity stages				3	3	3	4	4	4
Minimum capacity			%	33	33	33	25	25	25
<b>Refrigerant</b>				R410A (GWP=2088 Following ARI4)					
<b>Capacity control</b>				SmartVu™					
<b>Evaporator</b>				Direct-expansion plate heat exchanger					
Water volume			l	15,18	17,35	19,04	23,16	26,52	29,05
Water connections				Victaulic					
Inlet/outlet			in	2 1/2	2 1/2	2 1/2	3	3	3
Max. water-side operating pressure without hydraulic module				1000	1000	1000	1000	1000	1000
<b>Refrigerant connections</b>									
Discharge line diameter			in	1"3/8	1"3/8	1"3/8	1"1/8	1"1/8	1"1/8
Liquid line diameter			in	7/8"	7/8"	7/8"	7/8"	7/8"	7/8"
<b>Chassis paint color</b>				Color code: RAL7035					

- \* In accordance with standard EN14511-3:2022. Refrigerant piping equivalent length (without drier and valves) = 3 m.
- CS1 Cooling mode conditions: evaporator entering/leaving water temperature 12 °C/7 °C, saturated condensing temperature 45 °C, subcooling 5 K, evaporator fouling factor 0 m<sup>2</sup>K/W.
- CS2 Cooling mode conditions: evaporator entering/leaving water temperature 23 °C/18 °C, saturated condensing temperature 45 °C, subcooling 5 K, evaporator fouling factor 0 m<sup>2</sup>K/W.
- (1) Weight shown is a guideline only. Please refer to the unit nameplate
- (2) In dB ref=10<sup>-12</sup> W, (A) weighting. Declared dual number noise emission values in accordance with ISO 4871 (with an associated uncertainty of +/- 3dB(A)). Measured in accordance with ISO 9614-1.
- (3) The dimensions shown are for the standard unit. For other unit types please refer to the dimensional drawings.

## ELECTRICAL DATA

30WG without hydraulic module		020	025	030	035	040	045	050	060	070	080	090	
<b>Power circuit</b>													
Nominal voltage	V-ph-Hz	400-3-50											
Voltage range	V	360-440											
<b>Control circuit supply</b>													
24 V, via internal transformer													
<b>Maximum start-up current draw (Un)<sup>(1)</sup></b>													
Standard unit	A	98	142	142	147	158	197	161	162	170	183	226	
Unit with electronic starter option	A	53,9	78,1	78,1	80,9	86,9	108,4	96,8	97,9	104,1	112,3	137,4	
<b>Unit power factor at maximum capacity<sup>(2)</sup></b>													
		0,9	0,8	0,9	0,9	0,9	0,9	0,8	0,9	0,9	0,9	0,9	
<b>Maximum operating power input<sup>(2)</sup></b>													
		kW	9,2	10,8	11,7	13,7	15,1	17,1	21,5	23,3	27,3	30,3	34,2
<b>Nominal unit operating current draw<sup>(3)</sup></b>													
		A	10,5	13,2	13,8	15,6	16,2	20,2	26,4	27,6	31,2	32,4	40,4
<b>Maximum operating current draw (Un)<sup>(4)</sup></b>													
		A	15,6	18,7	19,8	23,2	25,4	29	37,4	39,6	46,4	50,8	58
<b>Maximum operating current draw (Un-10%)*</b>													
		A	17,3	20,8	22	25,8	28,2	32,2	41,6	44	51,6	56,4	64,4
<b>Customer-side unit power reserve</b>													
Customer reserve at the 24 V control power circuit													
<b>Short-circuit stability and protection</b>													
See table below "Short-circuit stability current"													

(1) Maximum instantaneous start-up current at operating limit values (maximum operating current of the smallest compressor(s) + locked rotor current or limited start-up current of the largest compressor).

(2) Maximum power input at the unit operating limits.

(3) Values obtained at standardised Eurovent conditions: evaporator entering/leaving water temperature 12 °C/7 °C, condenser entering/leaving water temperature 30 °C/ 35 °C.

(4) Maximum unit operating current at maximum unit power input and 400 V.

\* Maximum unit operating current at maximum unit power input and 360 V.

30WG without hydraulic module		110	120	140	150	170	190	
<b>Power circuit</b>								
Nominal voltage	V-ph-Hz	400-3-50						
Voltage range	V	360-440						
<b>Control circuit supply</b>								
24 V, via internal transformer								
<b>Maximum start-up current draw (Un)<sup>(1)</sup></b>								
Standard unit	A	193,4	208,8	255	216,6	234,2	284	
Unit with electronic starter option	A	127,3	137,7	166,4	150,5	163,1	195,4	
<b>Unit power factor at maximum capacity<sup>(2)</sup></b>								
		0,87	0,85	0,85	0,87	0,85	0,85	
<b>Maximum operating power input<sup>(2)</sup></b>								
		kW	41	45	51	55	60	68
<b>Nominal unit operating current draw<sup>(3)</sup></b>								
		A	46,8	48,6	60,6	62,4	64,8	80,8
<b>Maximum operating current draw (Un)<sup>(4)</sup></b>								
		A	69,6	76,2	87	92,8	101,6	116
<b>Maximum operating current draw (Un-10%)*</b>								
		A	77,3	84,7	96,7	103,1	112,9	128,9
<b>Customer-side unit power reserve</b>								
Customer reserve at the 24 V control power circuit								
<b>Short-circuit stability and protection</b>								
See table below "Short-circuit stability current"								

(1) Maximum instantaneous start-up current at operating limit values (maximum operating current of the smallest compressor(s) + locked rotor current or limited start-up current of the largest compressor).

(2) Maximum power input at the unit operating limits.

(3) Values obtained at standardised Eurovent conditions: evaporator entering/leaving water temperature 12 °C/7 °C, condenser entering/leaving water temperature 30 °C/ 35 °C.

(4) Maximum unit operating current at maximum unit power input and 400 V.

\* Maximum unit operating current at maximum unit power input and 360 V.

## ELECTRICAL DATA

30WGA without hydraulic module		020	025	030	035	040	045	050	060	070	080	090
<b>Power circuit</b>												
Nominal voltage	V-ph-Hz	400-3-50										
Voltage range	V	360-440										
<b>Control circuit supply</b>												
24 V, via internal transformer												
<b>Maximum start-up current draw (Un)<sup>(1)</sup></b>												
Standard unit	A	98	142	142	147	158	197	161	162	170	183	226
Unit with electronic starter option	A	53,9	78,1	78,1	80,9	86,9	108,4	96,8	97,9	104,1	112,3	137,4
<b>Unit power factor at maximum capacity<sup>(2)</sup></b>												
0,9												
<b>Maximum operating power input<sup>(2)</sup></b>												
kW												
9,2 10,8 11,7 13,7 15,1 17,1 21,5 23,3 27,3 30,3 34,2												
<b>Nominal unit operating current draw<sup>(3)</sup></b>												
A												
11,4 13,8 14,7 16,5 18,1 21,2 27,6 29,4 33,1 36,4 42,5												
<b>Maximum operating current draw (Un)<sup>(4)</sup></b>												
A												
15,6 18,7 19,8 23,2 25,4 29 37,4 39,6 46,4 50,8 58												
<b>Maximum operating current draw (Un-10%)*</b>												
A												
17,3 20,8 22 25,8 28,2 32,2 41,6 44 51,6 56,4 64,4												
<b>Customer-side unit power reserve</b>												
Customer reserve at the 24 V control power circuit												
<b>Short-circuit stability and protection</b>												
See table below "Short-circuit stability current"												

30WGA without hydraulic module		110	120	140	150	170	190
<b>Power circuit</b>							
Nominal voltage	V-ph-Hz	400-3-50					
Voltage range	V	360-440					
<b>Control circuit supply</b>							
24 V, via internal transformer							
<b>Maximum start-up current draw (Un)<sup>(1)</sup></b>							
Standard unit	A	193,4	208,8	255	216,6	234,2	284
Unit with electronic starter option	A	127,3	137,7	166,4	150,5	163,1	195,4
<b>Unit power factor at maximum capacity<sup>(2)</sup></b>							
0,87 0,85 0,85 0,87 0,85 0,85							
<b>Maximum operating power input<sup>(2)</sup></b>							
kW							
41 45 51 55 60 68							
<b>Nominal unit operating current draw<sup>(3)</sup></b>							
A							
49,5 54,3 63,6 66 72,4 84,8							
<b>Maximum operating current draw (Un)<sup>(4)</sup></b>							
A							
69,6 76,2 87 92,8 101,6 116							
<b>Maximum operating current draw (Un-10%)*</b>							
A							
77,3 84,7 96,7 103,1 112,9 128,9							
<b>Customer-side unit power reserve</b>							
Customer reserve at the 24 V control power circuit							
<b>Short-circuit stability and protection</b>							
See table below "Short-circuit stability current"							

- (1) Maximum instantaneous start-up current at operating limit values (maximum operating current of the smallest compressor(s) + locked rotor current or limited start-up current of the largest compressor).
- (2) Maximum power input at the unit operating limits.
- (3) Values obtained at the following conditions: evaporator entering/leaving water temperature 12 °C/7 °C, condenser entering/leaving water temperature 45 °C.
- (4) Maximum unit operating current at maximum unit power input and 400 V.

\* Maximum unit operating current at maximum unit power input and 360 V.

## DIMENSIONS/CLEARANCES

### 30WG 020-045 - standard unit

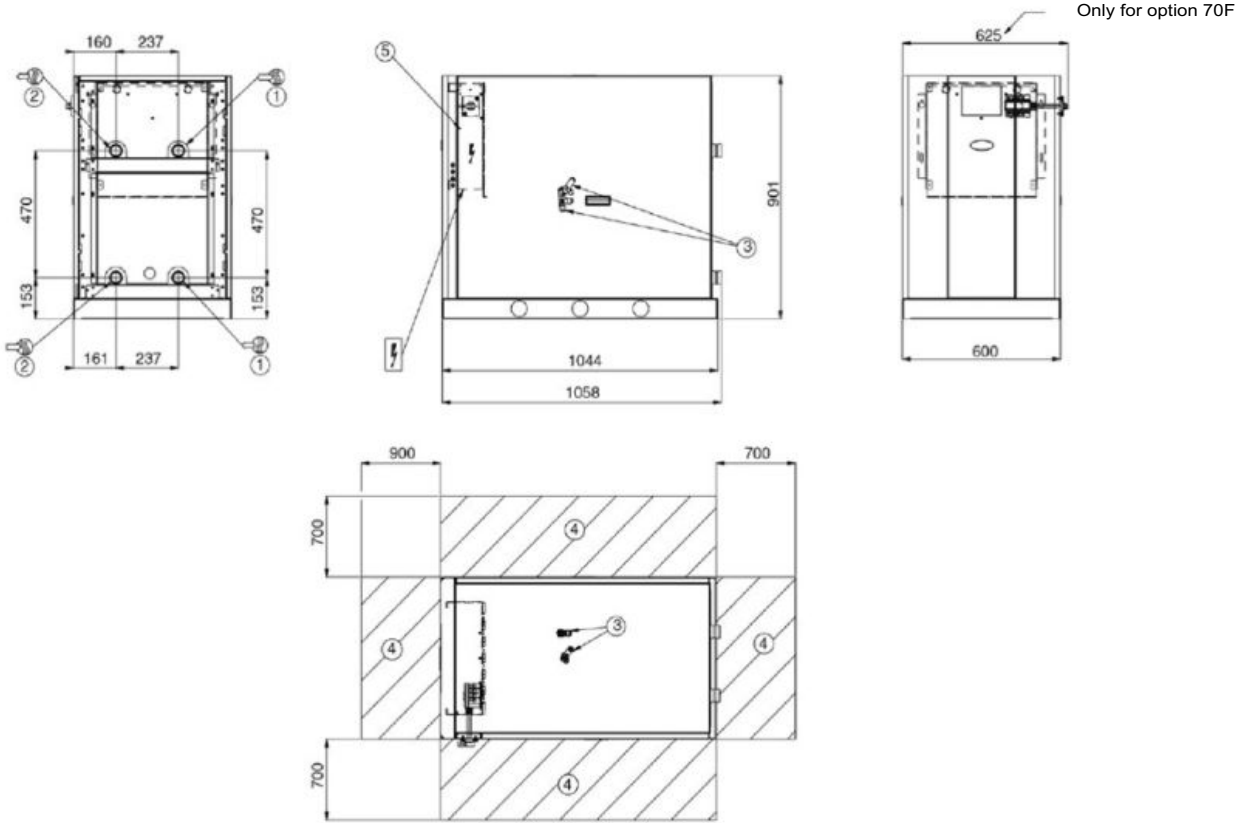

### 30WG 020-045 - unit with top connections (option 274)

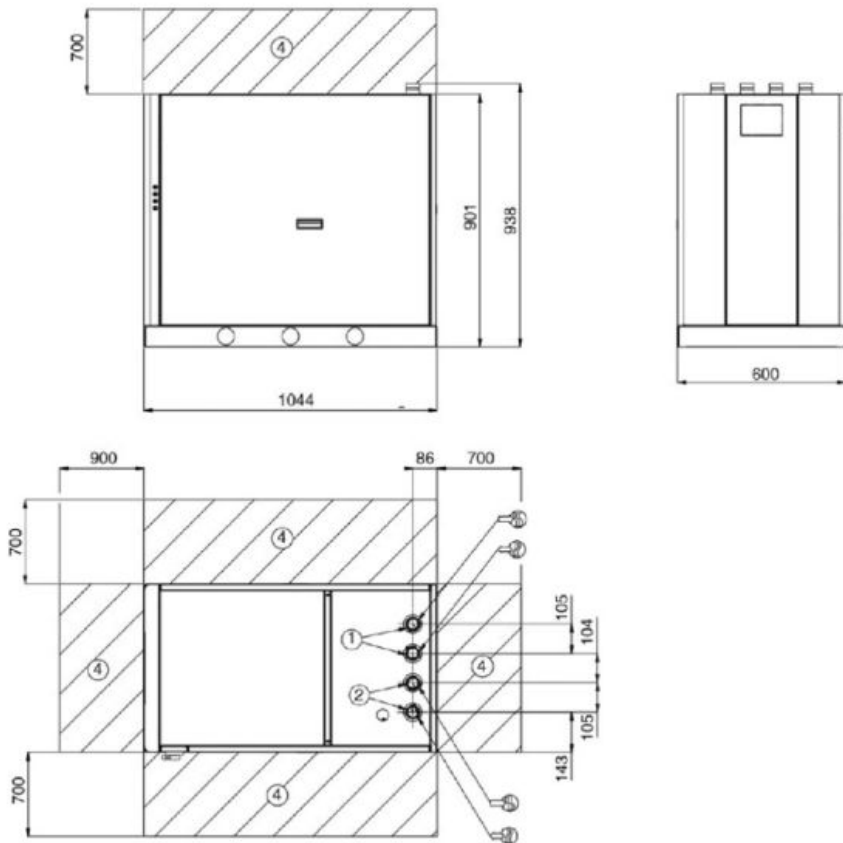

**Legend**

All dimensions are in mm.

- ① Evaporator
- ② Condenser
- ③ Safety valve
- ④ Clearances required for maintenance (see note)
- ⑤ Control box
- Water inlet.
- Water outlet
- Power wiring connection

**NOTE:** Non-contractual drawings. Refer to the certified dimensional drawings available on request, when designing an installation.

## DIMENSIONS/CLEARANCES

### 30WG 020-045 - unit with evaporator hydraulic module (option 116)

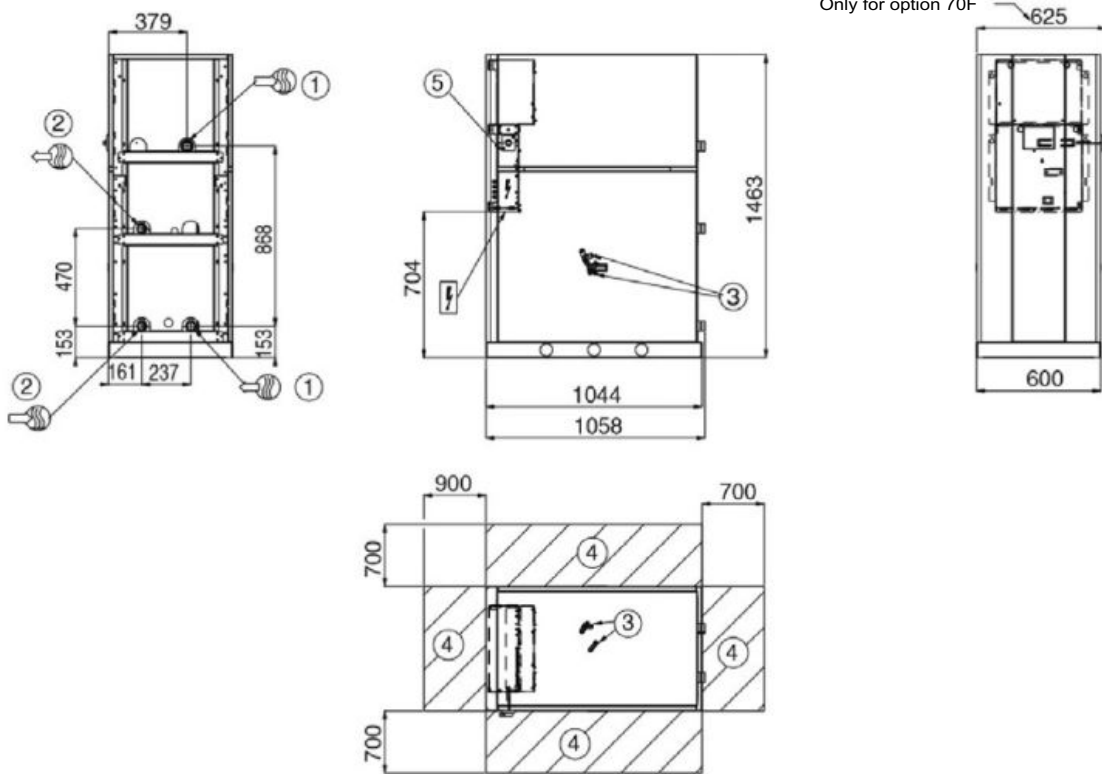

### 30WG 020-045 - unit with condenser hydraulic module (option 270)

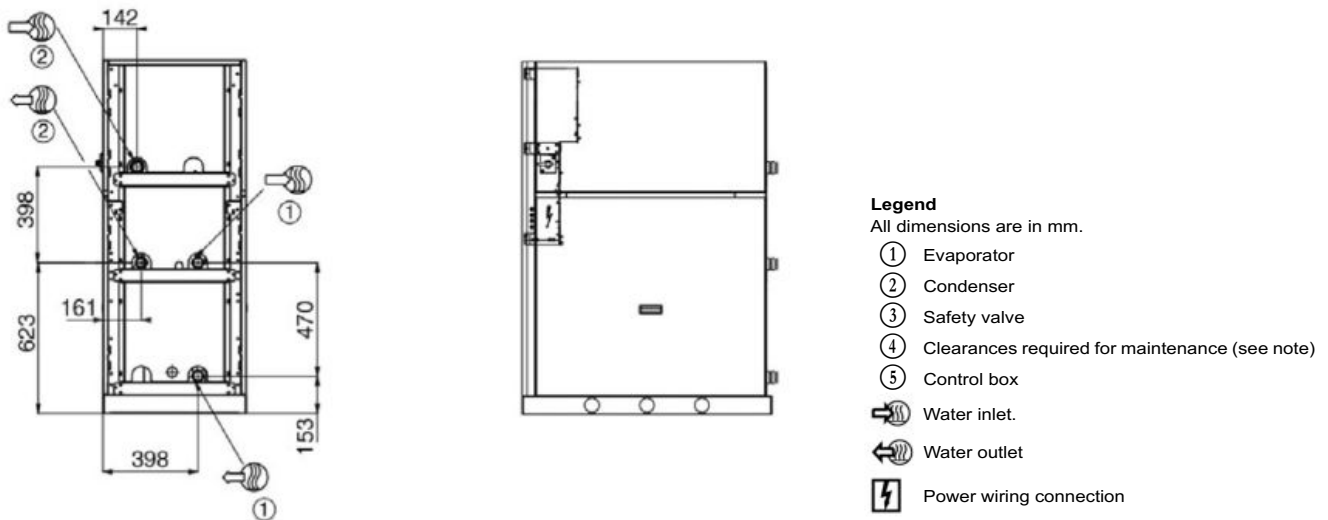

**NOTE:** Non-contractual drawings. Refer to the certified dimensional drawings available on request, when designing an installation.



## DIMENSIONS/CLEARANCES

30WG 020-045 - unit with evaporator/condenser hydraulic modules (options 116 + 270)

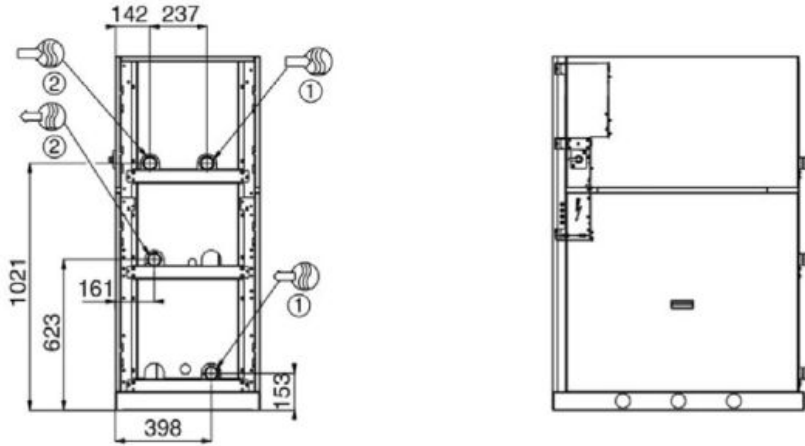

30WG 020-045 - unit with hydraulic module and top connections (options 116 + 274 or 270 + 274 or 116 + 270 + 274)

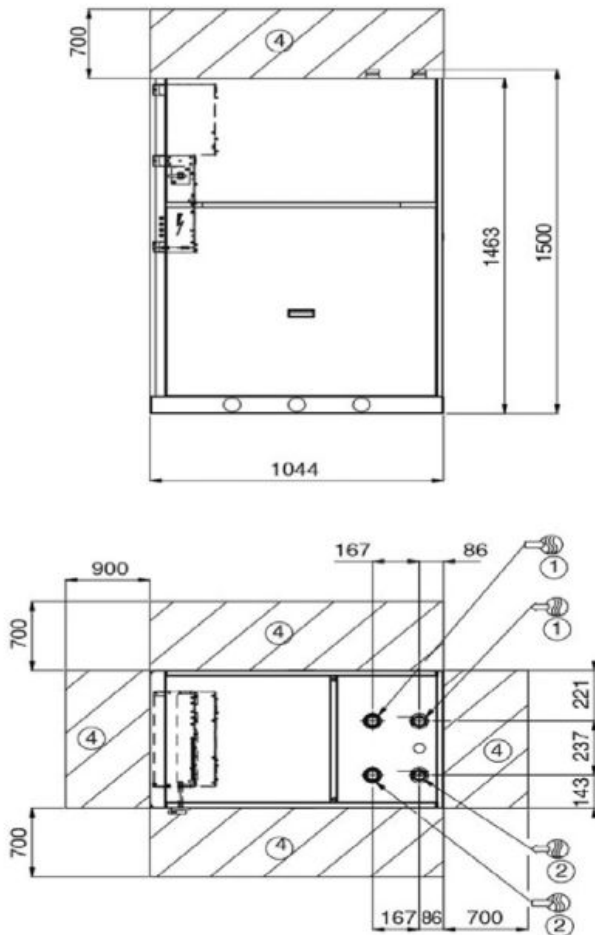

**Legend**

All dimensions are in mm.

- ① Evaporator
- ② Condenser
- ③ Safety valve
- ④ Clearances required for maintenance (see note)
- ⑤ Control box
- Water inlet.
- Water outlet
- Power wiring connection

**NOTE:** Non-contractual drawings. Refer to the certified dimensional drawings available on request, when designing an installation.

## DIMENSIONS/CLEARANCES

### 30WG 020-045 - stackable unit (option 273)

**NOTE:** The water and electrical connections are identical to those of the standard unit.

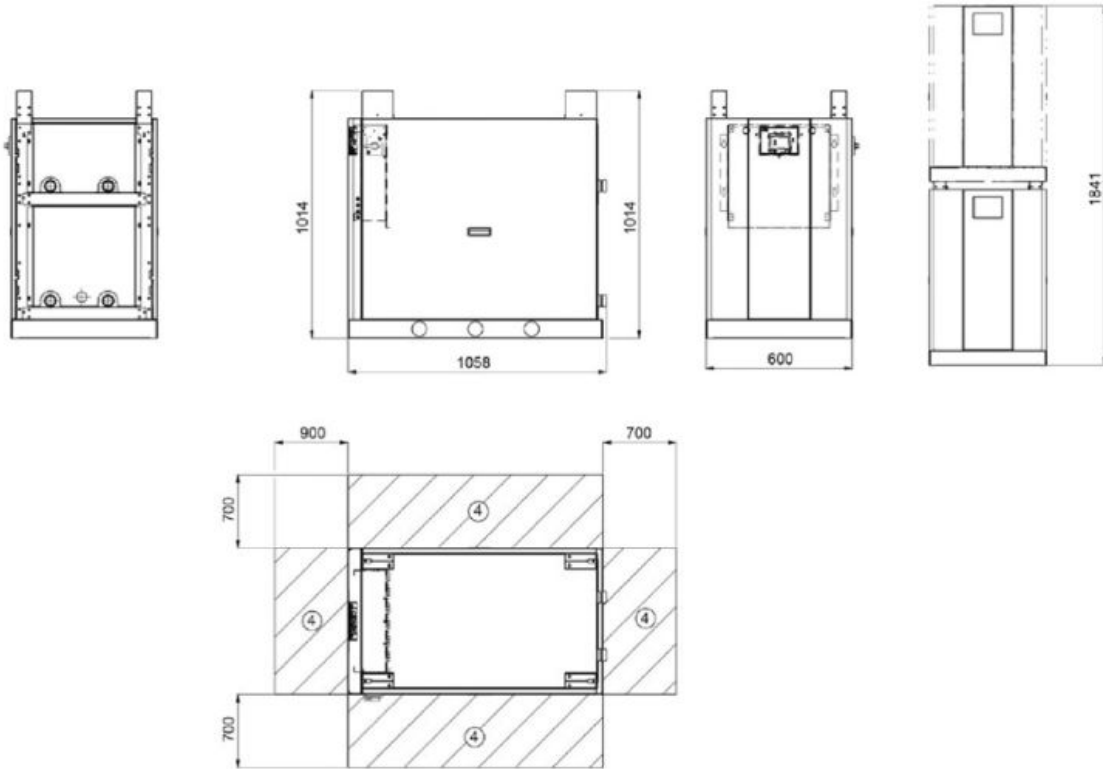

### 30WG 050-090 - standard unit

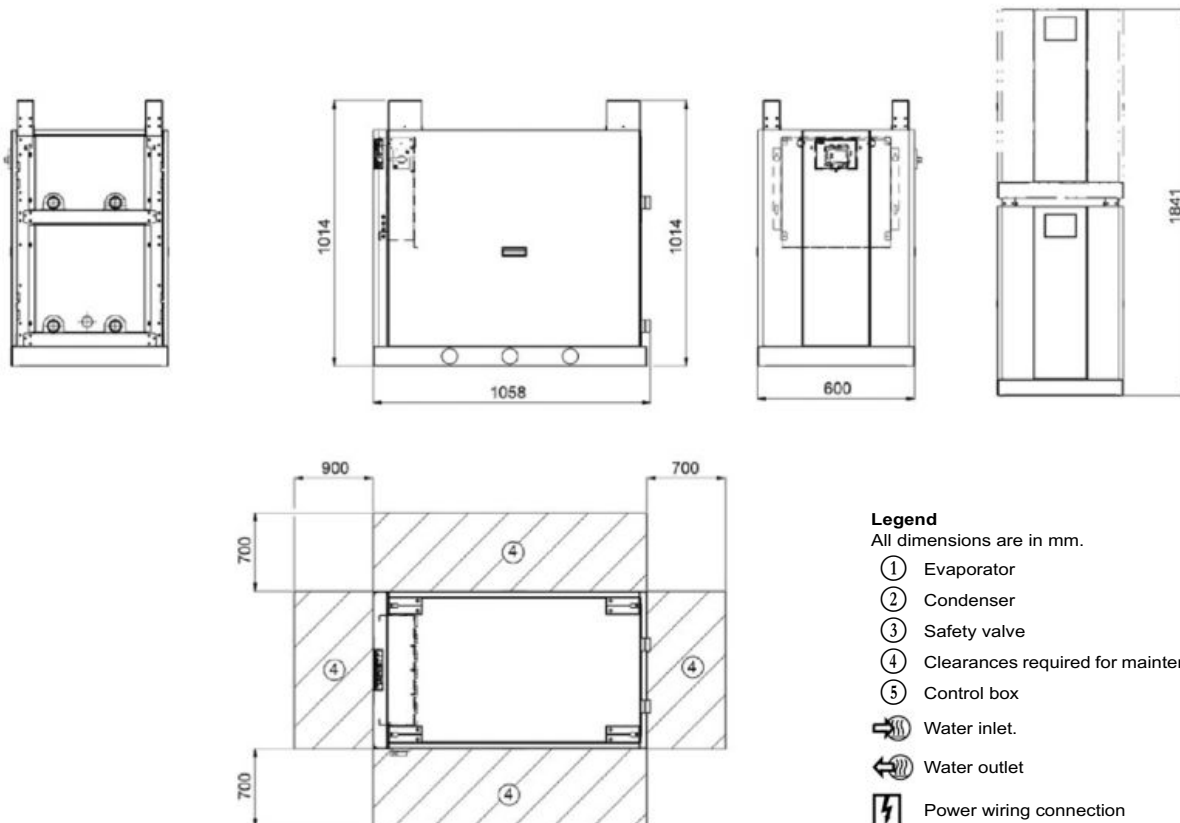

**Legend**

All dimensions are in mm.

- ① Evaporator
- ② Condenser
- ③ Safety valve
- ④ Clearances required for maintenance (see note)
- ⑤ Control box
- Water inlet.
- Water outlet
- Power wiring connection

**NOTE:** Non-contractual drawings. Refer to the certified dimensional drawings available on request, when designing an installation.

## DIMENSIONS/CLEARANCES

### 30WG 050-090 - unit with top connections (option 274)

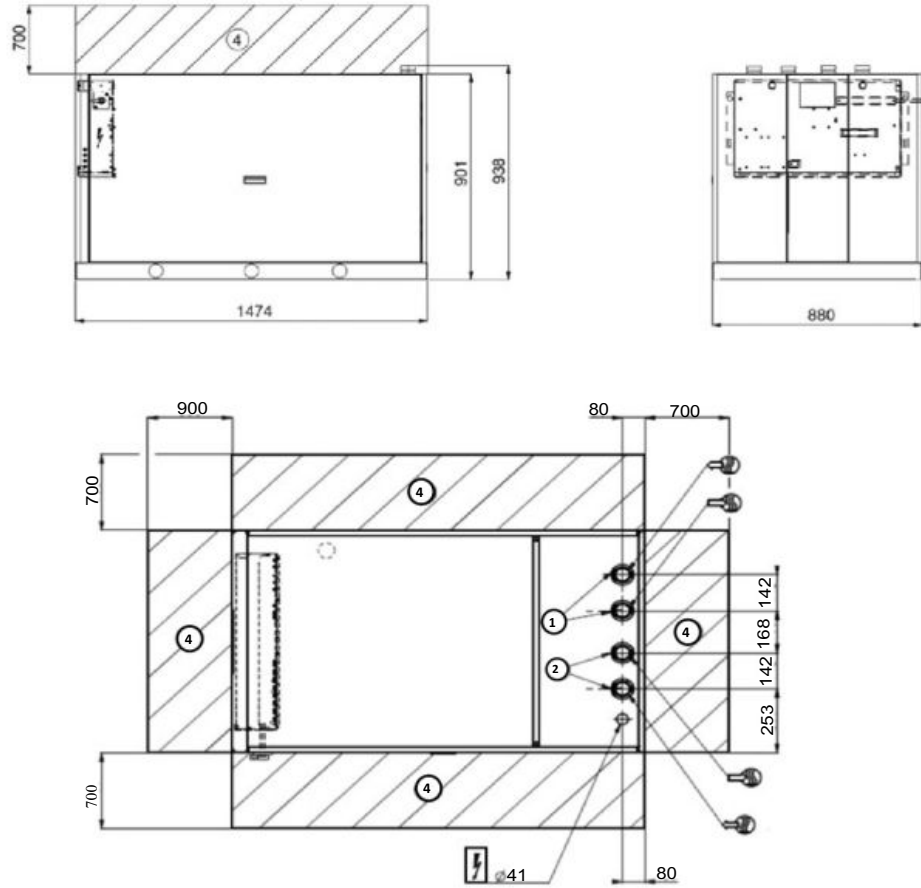

### 30WG 050-090 - unit with evaporator hydraulic module (option 116)

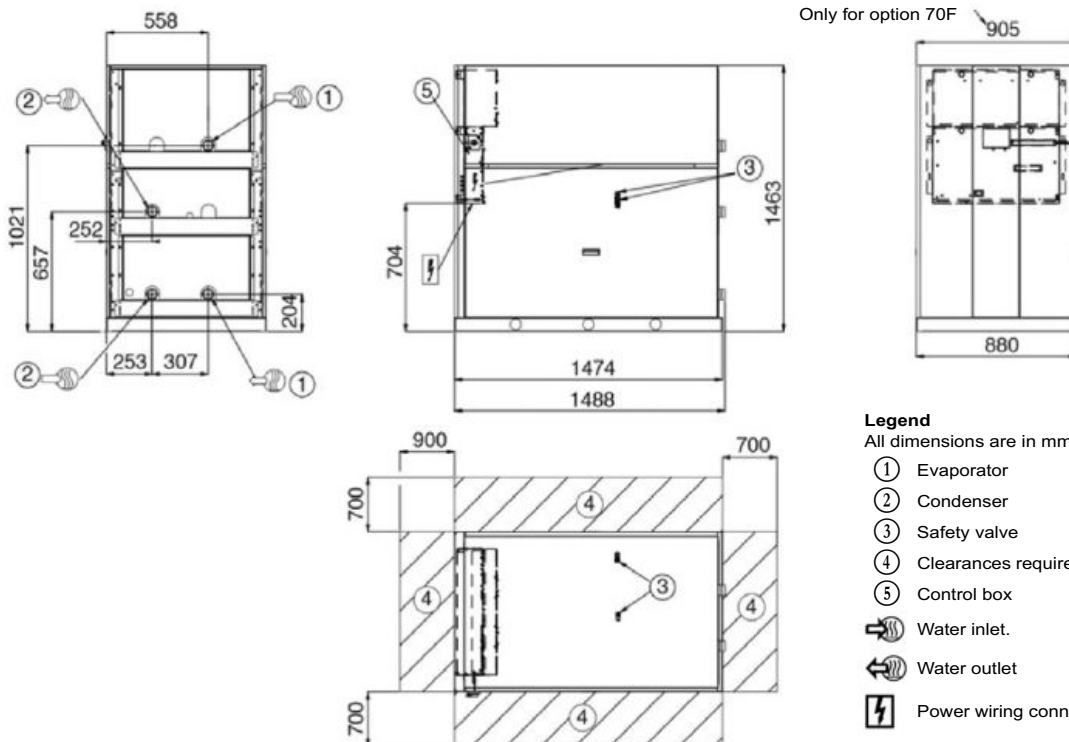

**NOTE:** Non-contractual drawings. Refer to the certified dimensional drawings available on request, when designing an installation.

## DIMENSIONS/CLEARANCES

### 30WG 050-090 - unit with condenser hydraulic module (option 270)

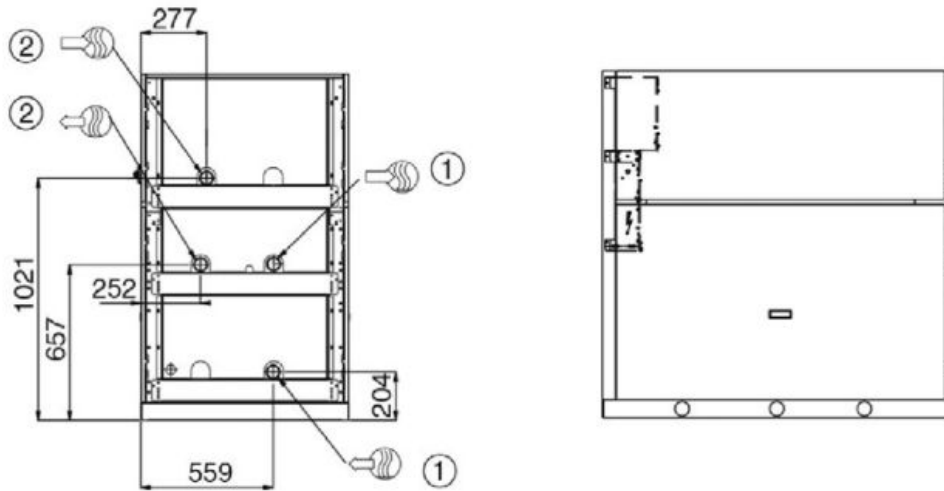

### 30WG 050-090 - unit with evaporator/condenser hydraulic modules (options 116 + 270)

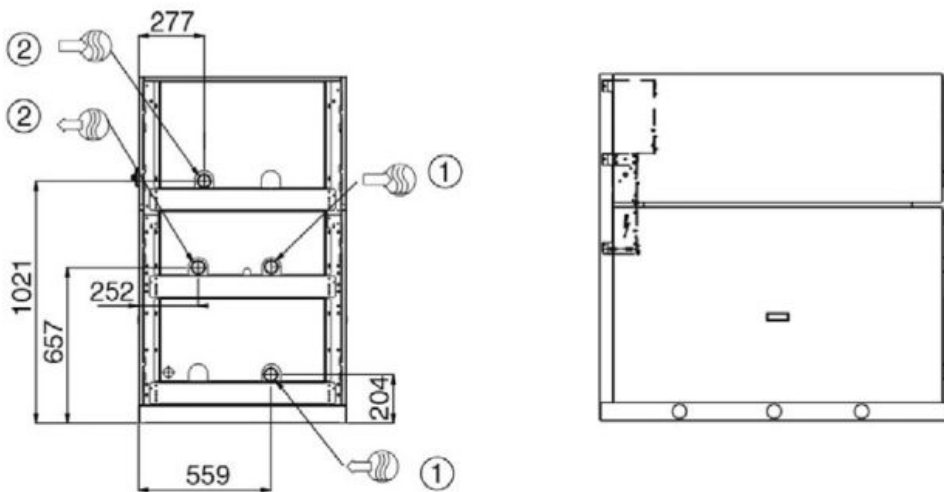

#### Legend

All dimensions are in mm.

- ① Evaporator
- ② Condenser
- ③ Safety valve
- ④ Clearances required for maintenance (see note)
- ⑤ Control box
- Water inlet.
- Water outlet
- Power wiring connection

**NOTE:** Non-contractual drawings. Refer to the certified dimensional drawings available on request, when designing an installation.

## DIMENSIONS/CLEARANCES

**30WG 050-090 - unit with hydraulic module and top connections (options 116 + 274 or 270 + 274 or 116 + 270 + 274)**

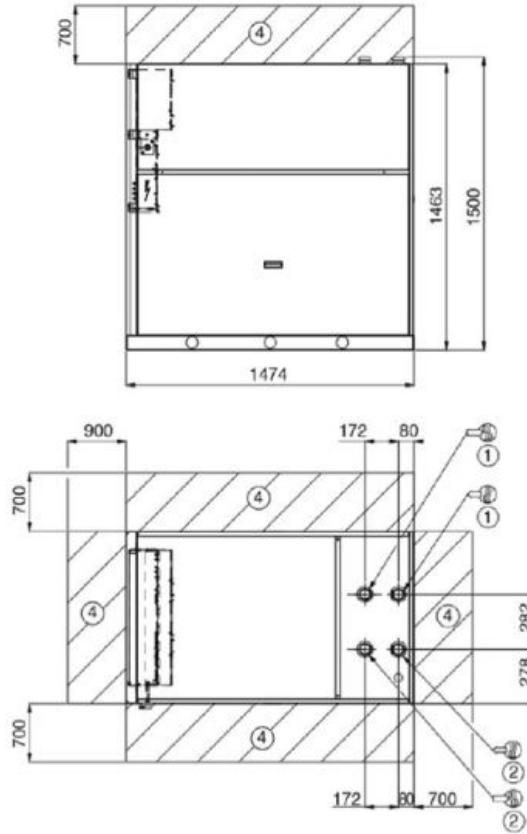

**30WG 050-090 - stackable unit (option 273)**

**NOTE:** The water and electrical connections are identical to those of the standard unit.

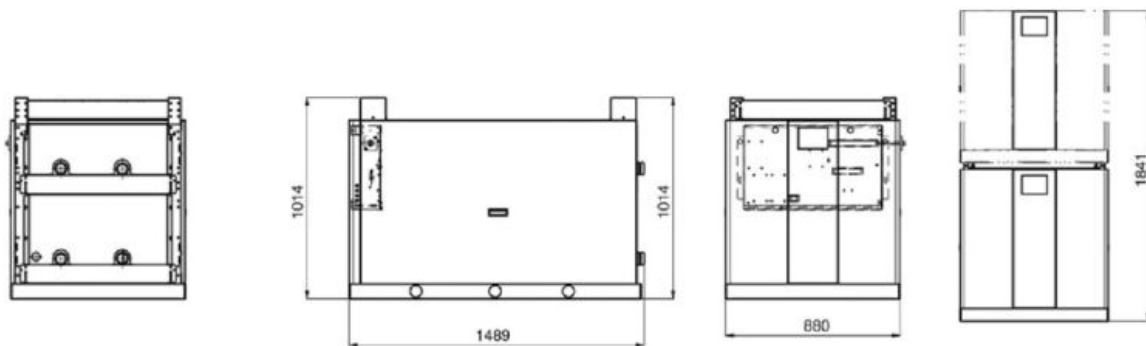

**Legend**

All dimensions are in mm.

- ① Evaporator
- ② Condenser
- ③ Safety valve
- ④ Clearances required for maintenance (see note)
- ⑤ Control box
- Water inlet.
- Water outlet
- Power wiring connection

**NOTE:** Non-contractual drawings. Refer to the certified dimensional drawings available on request, when designing an installation.



## DIMENSIONS/CLEARANCES

### 30WGA 110-140 - Standard unit

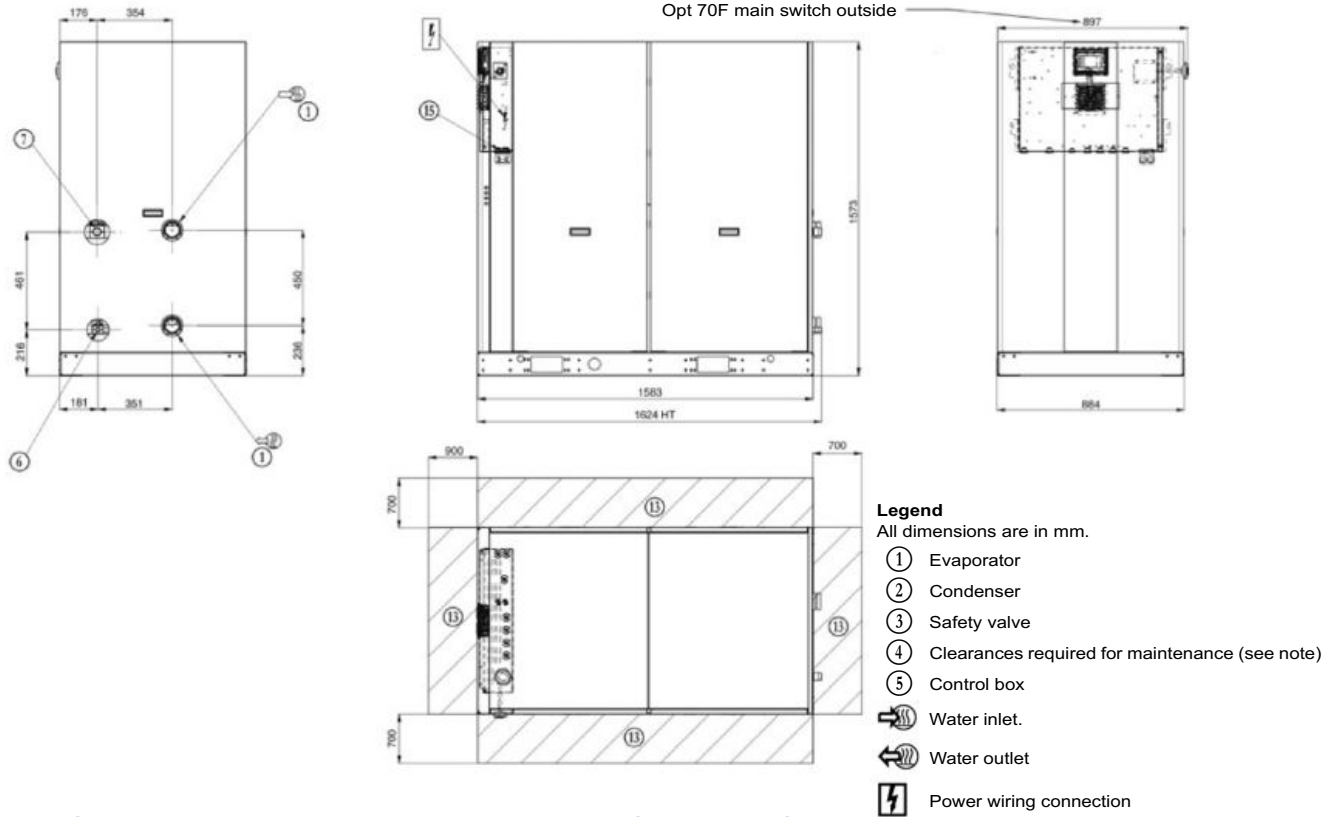

### 30WGA 110-140 - Unit with hydraulic module (option 116)

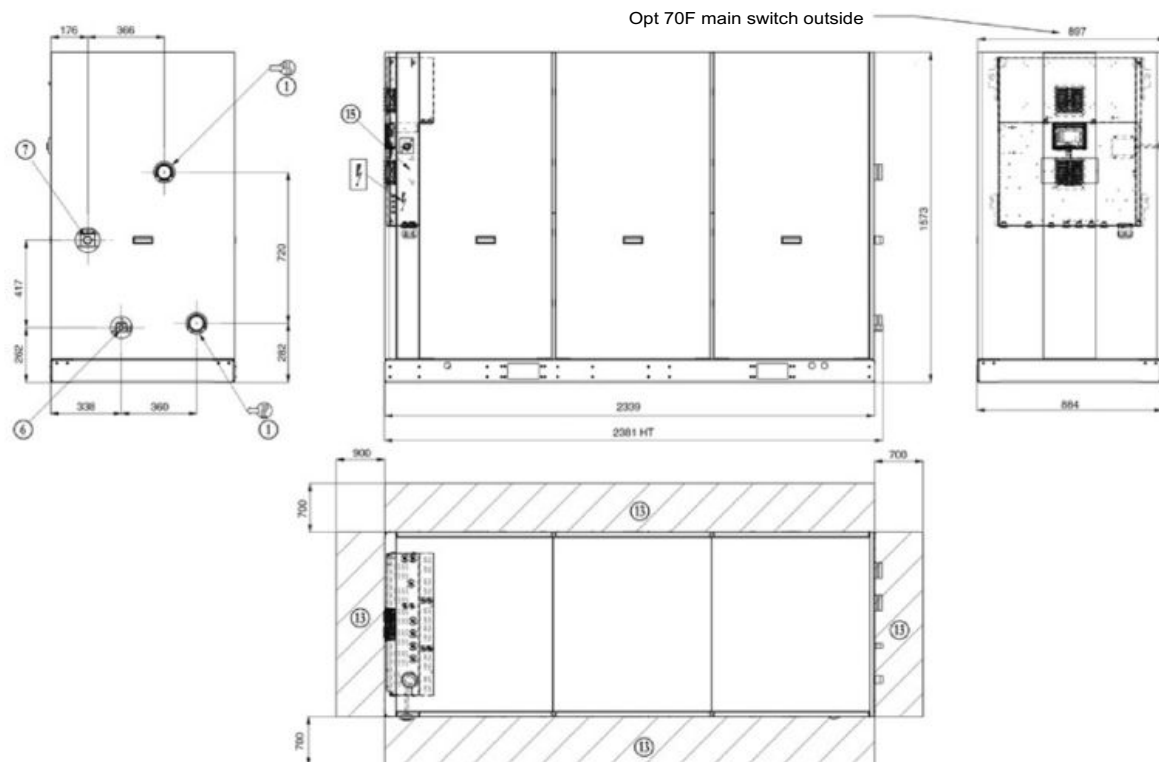

**NOTE:** Non-contractual drawings. Refer to the certified dimensional drawings available on request, when designing an installation.

## DIMENSIONS/CLEARANCES

### 30WGA 150-190 - Standard unit

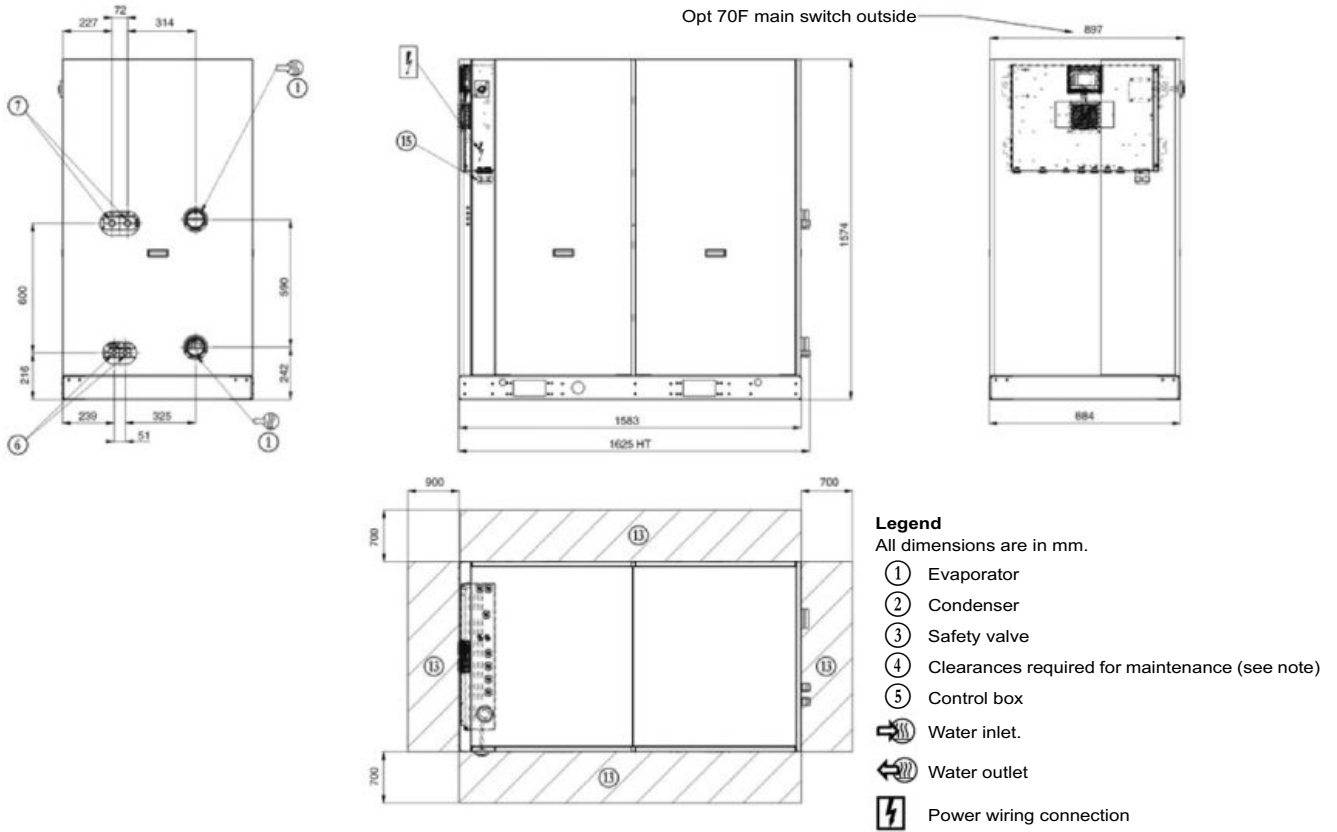

### 30WGA 150-190 - Unit with hydraulic module (option 116)

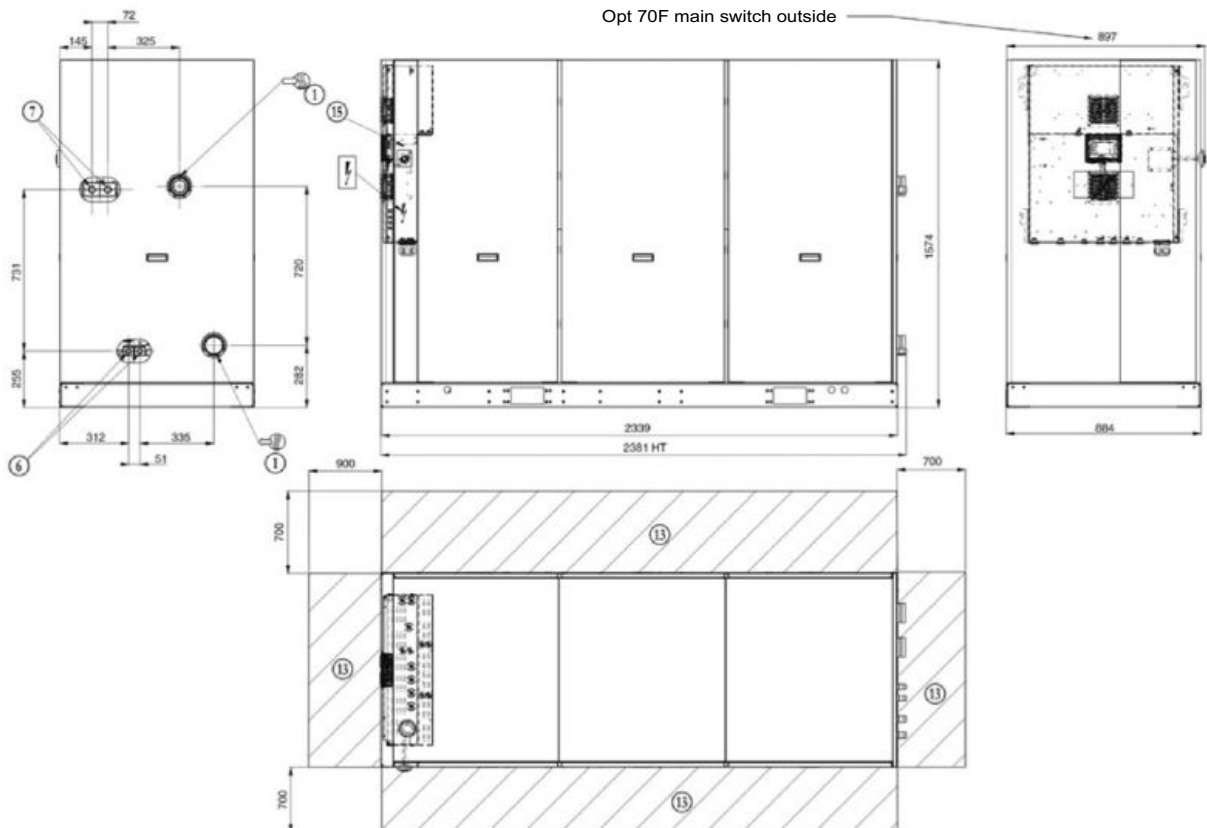

**NOTE:** Non-contractual drawings. Refer to the certified dimensional drawings available on request, when designing an installation.

## DIMENSIONS/CLEARANCES

### 30WG 110-140 - unit with hydraulic module (option 116-270)

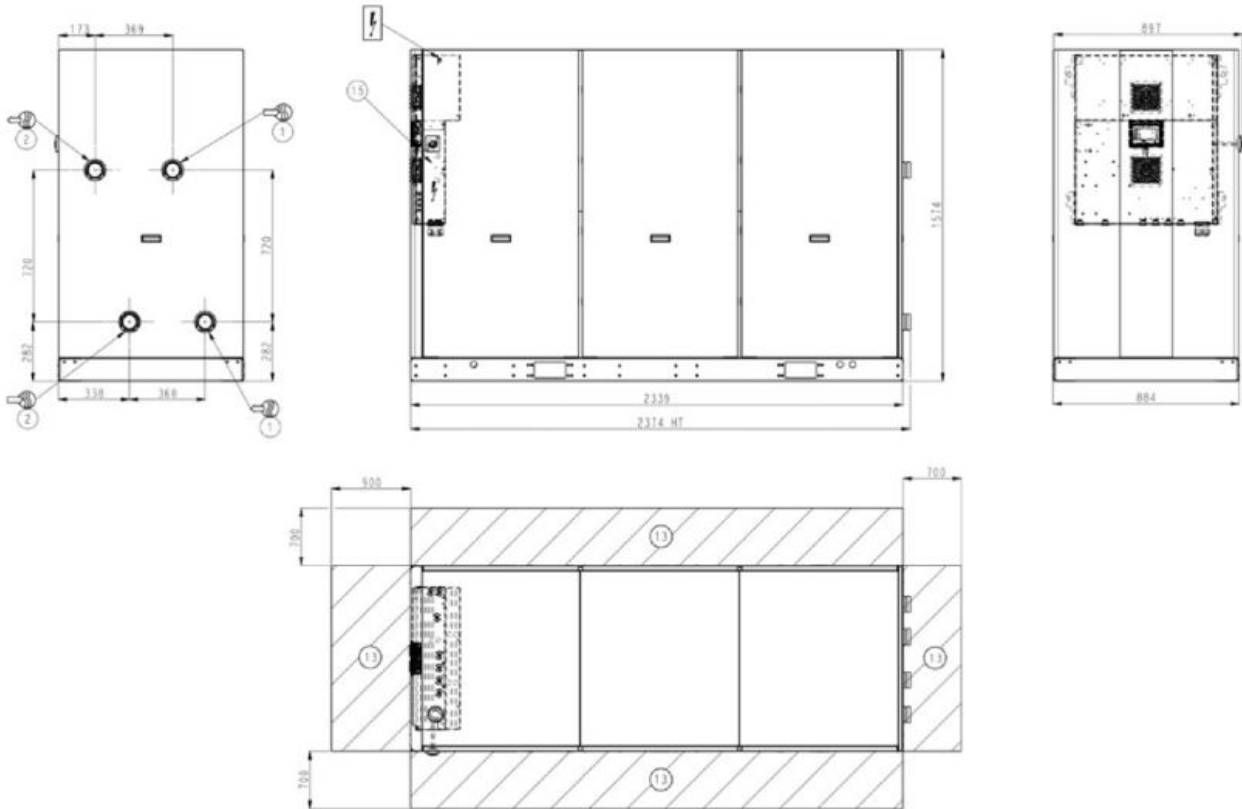

### 30WG 110-140 - unit with hydraulic module and top connections (option 116-270 and 274)

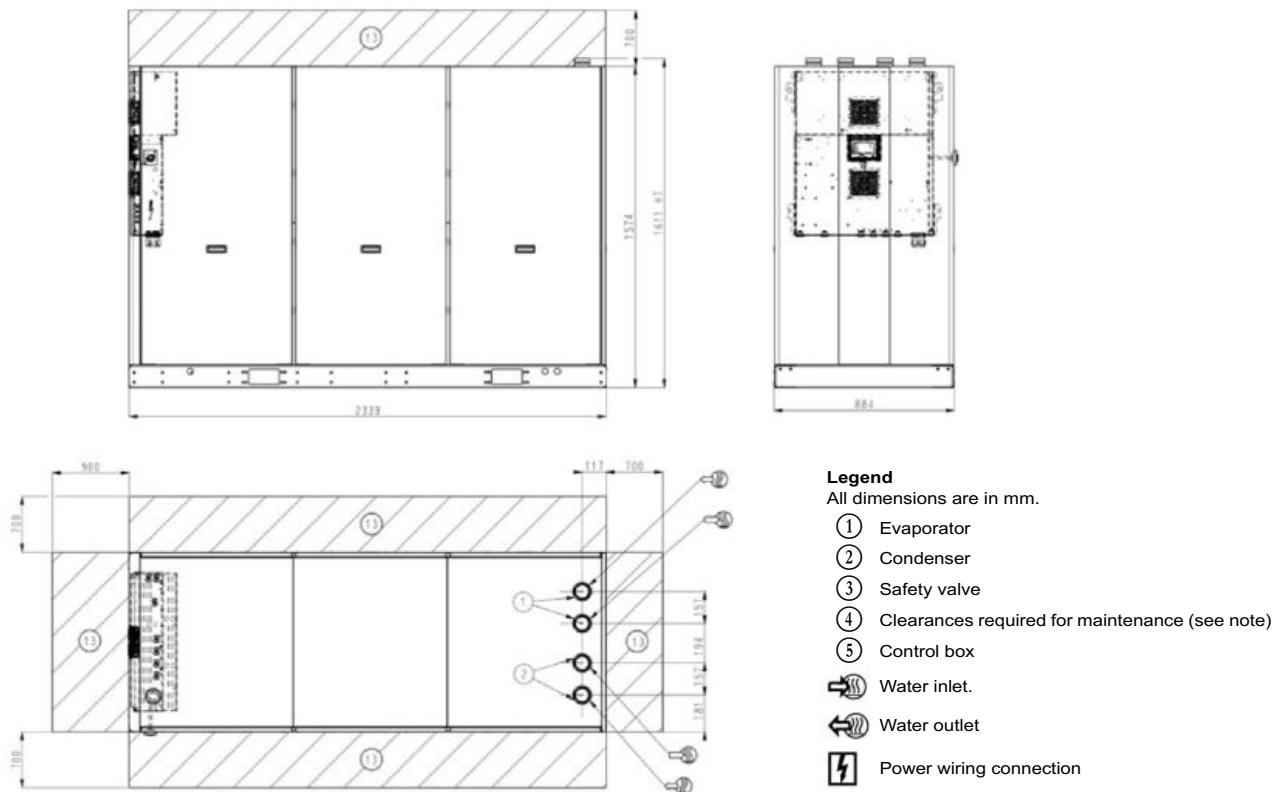

**NOTE:** Non-contractual drawings. Refer to the certified dimensional drawings available on request, when designing an installation.

## DIMENSIONS/CLEARANCES

### 30WG 150-190 - unit with hydraulic module (option 116-270)

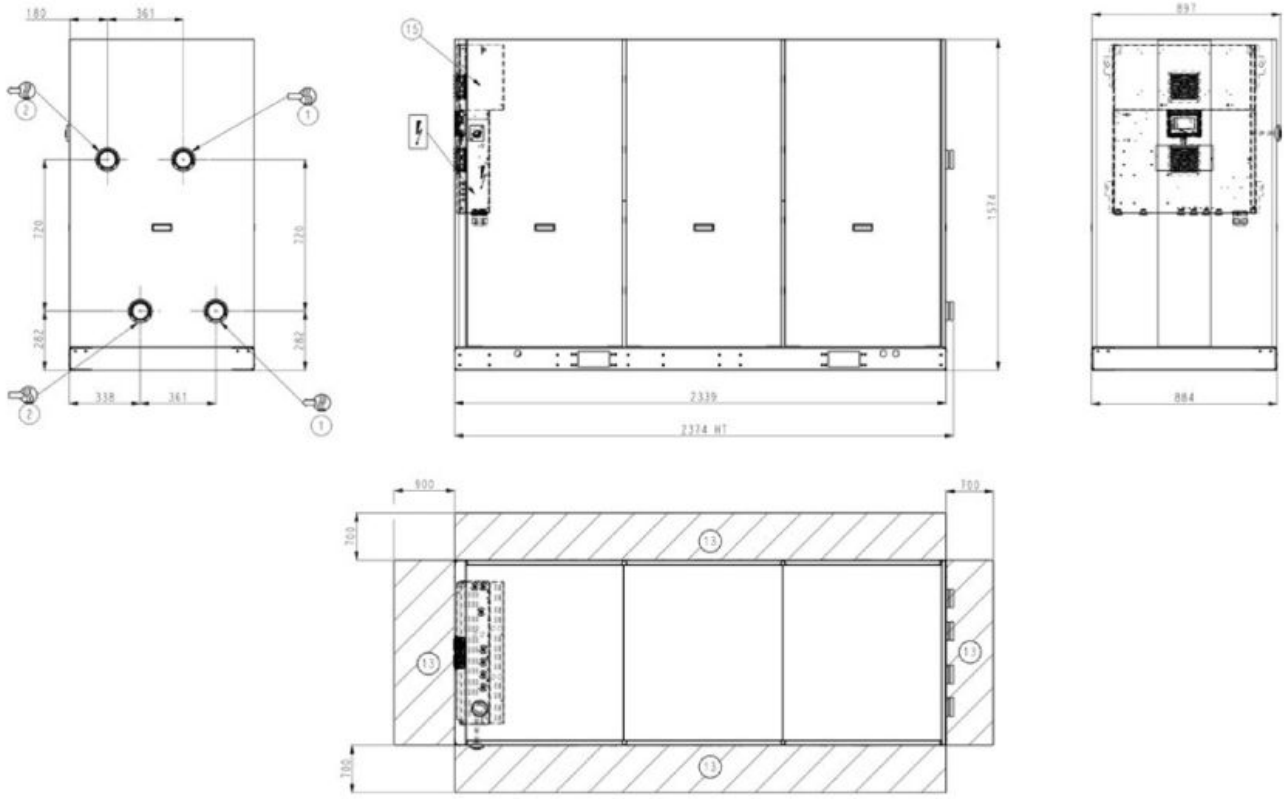

### 30WG 150-190 - unit with hydraulic module and top connections (option 116-270 and 274)

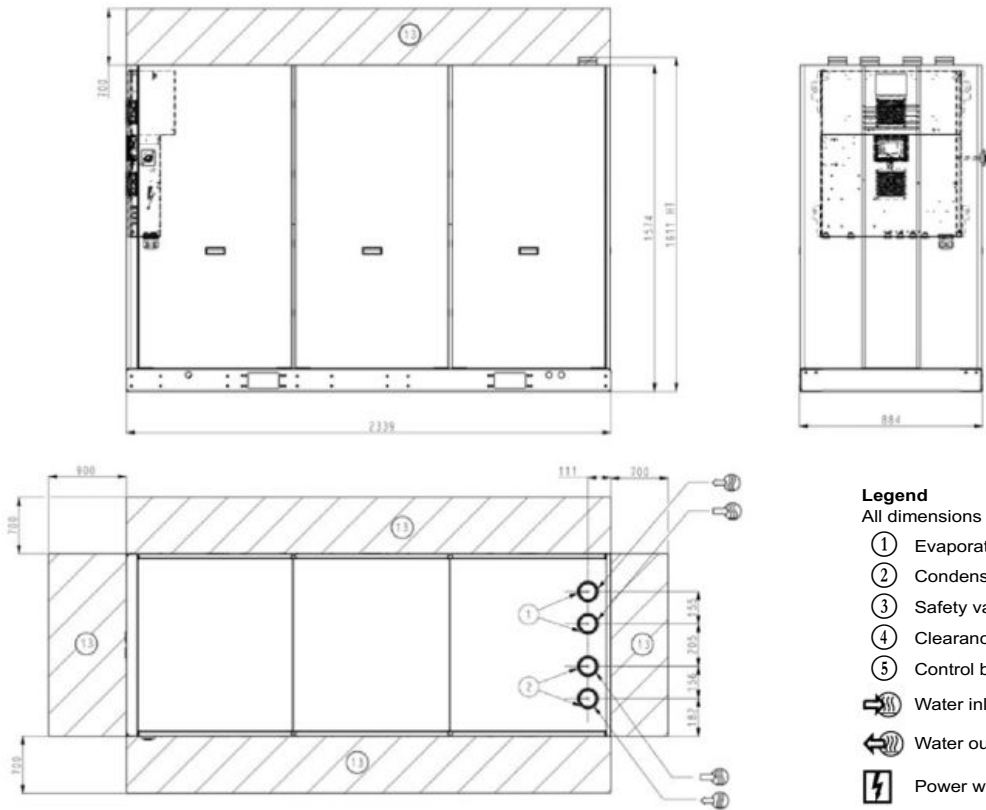

**Legend**

All dimensions are in mm.

- ① Evaporator
- ② Condenser
- ③ Safety valve
- ④ Clearances required for maintenance (see note)
- ⑤ Control box
- Water inlet.
- Water outlet
- Power wiring connection

**NOTE:** Non-contractual drawings. Refer to the certified dimensional drawings available on request, when designing an installation.

## DIMENSIONS/CLEARANCES

### 30WGA 020-045 - standard unit

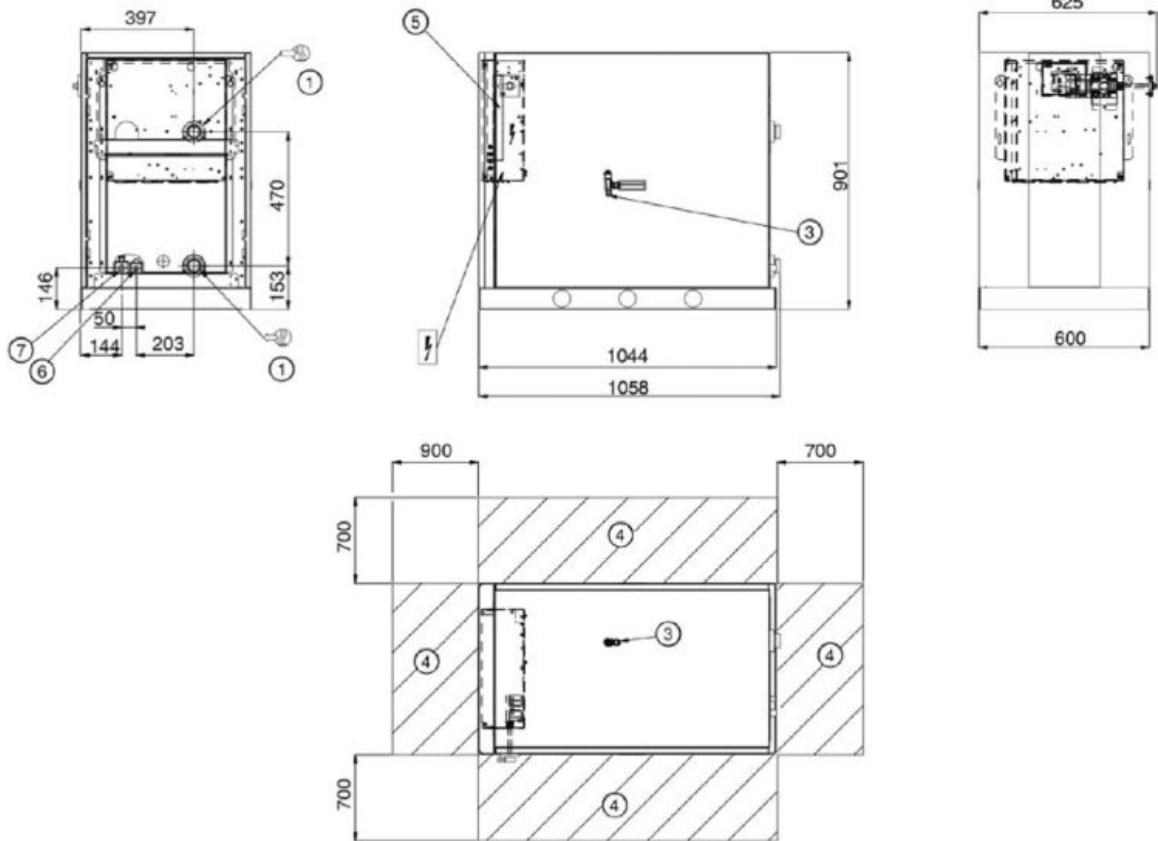

### 30WGA 020-045 - unit with evaporator hydraulic module (option 116)

For option 70F only

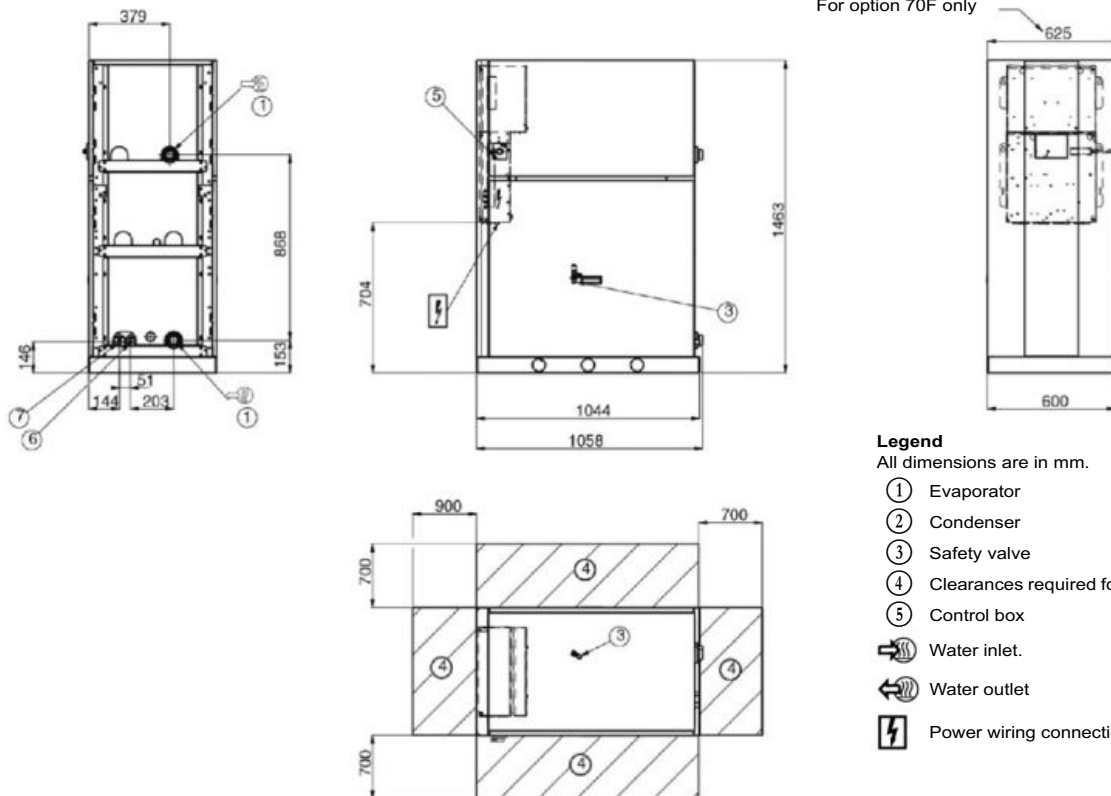

#### Legend

All dimensions are in mm.

- ① Evaporator
- ② Condenser
- ③ Safety valve
- ④ Clearances required for maintenance (see note)
- ⑤ Control box
- Water inlet.
- Water outlet
- Power wiring connection

**NOTE:** Non-contractual drawings. Refer to the certified dimensional drawings available on request, when designing an installation.



## DIMENSIONS/CLEARANCES

### 30WGA 020-045 - stackable unit (option 273)

**NOTE:** The water and electrical connections are identical to those of the standard unit.

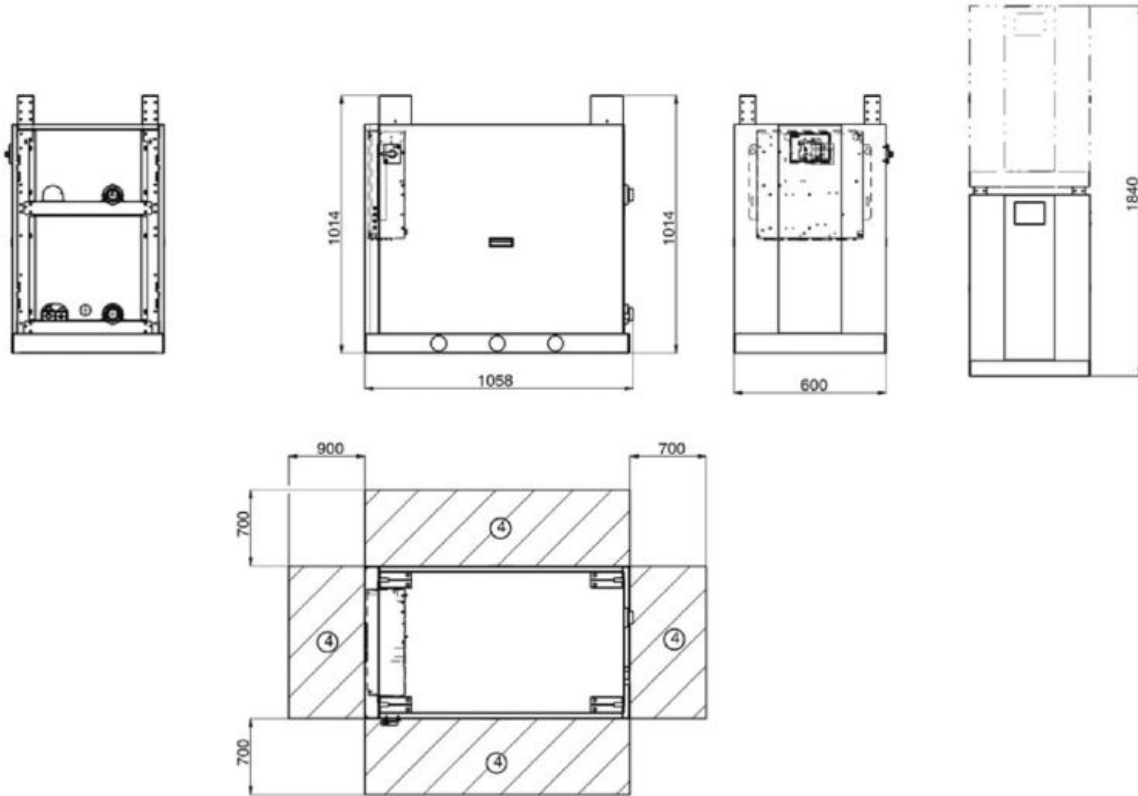

### 30WGA 050-090 - standard unit

For option 70F only

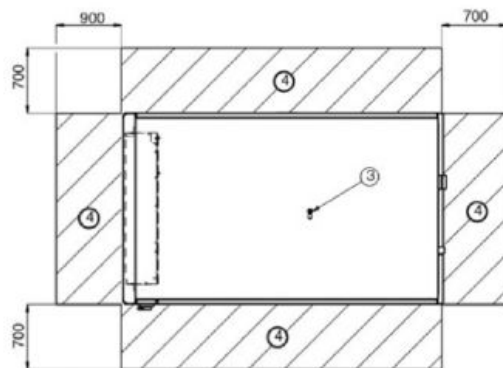
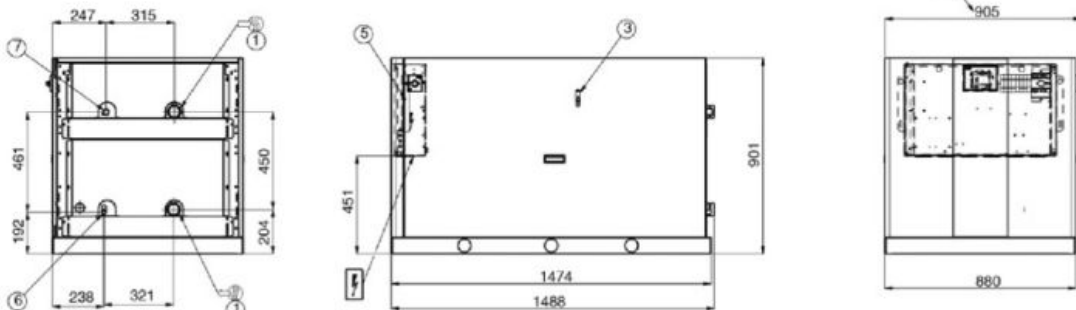

**Legend**

All dimensions are in mm.

- ① Evaporator
- ② Condenser
- ③ Safety valve
- ④ Clearances required for maintenance (see note)
- ⑤ Control box
- Water inlet.
- Water outlet
- Power wiring connection

**NOTE:** Non-contractual drawings. Refer to the certified dimensional drawings available on request, when designing an installation.

## DIMENSIONS/CLEARANCES

### 30WGA 050-090 - unit with evaporator hydraulic module (option 116)

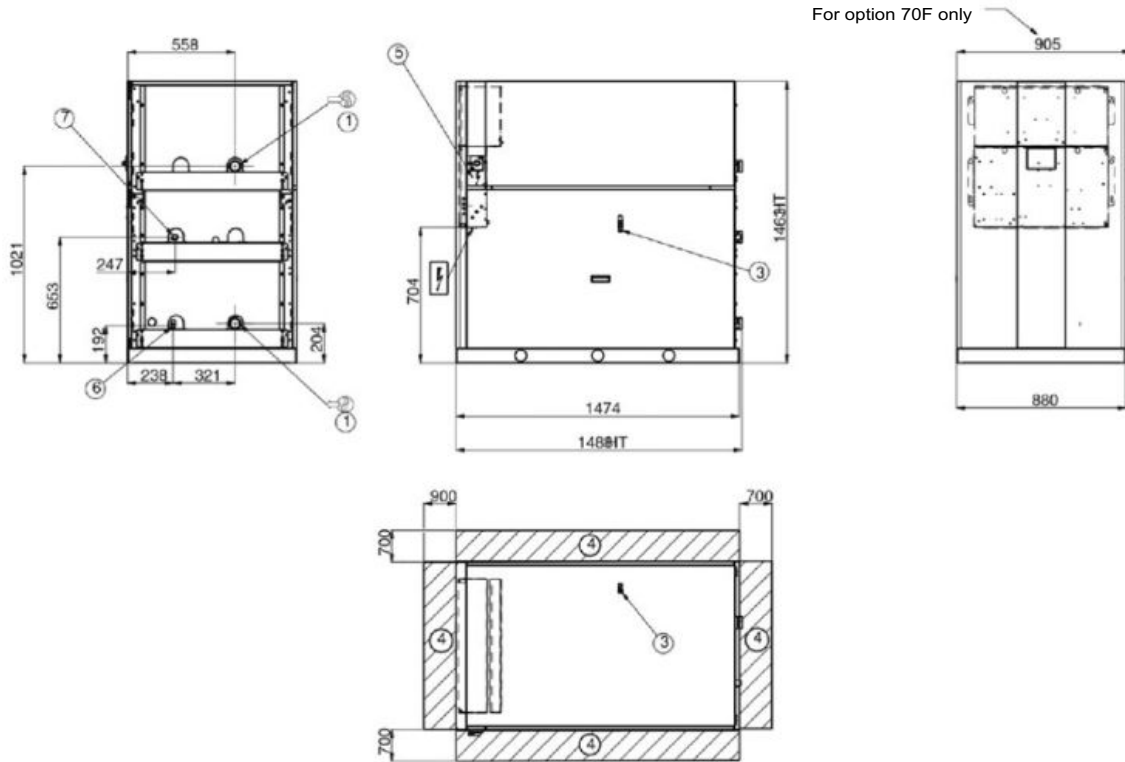

### 30WGA 050-090 - stackable unit (option 273)

**NOTE:** The water and electrical connections are identical to those of the standard unit.

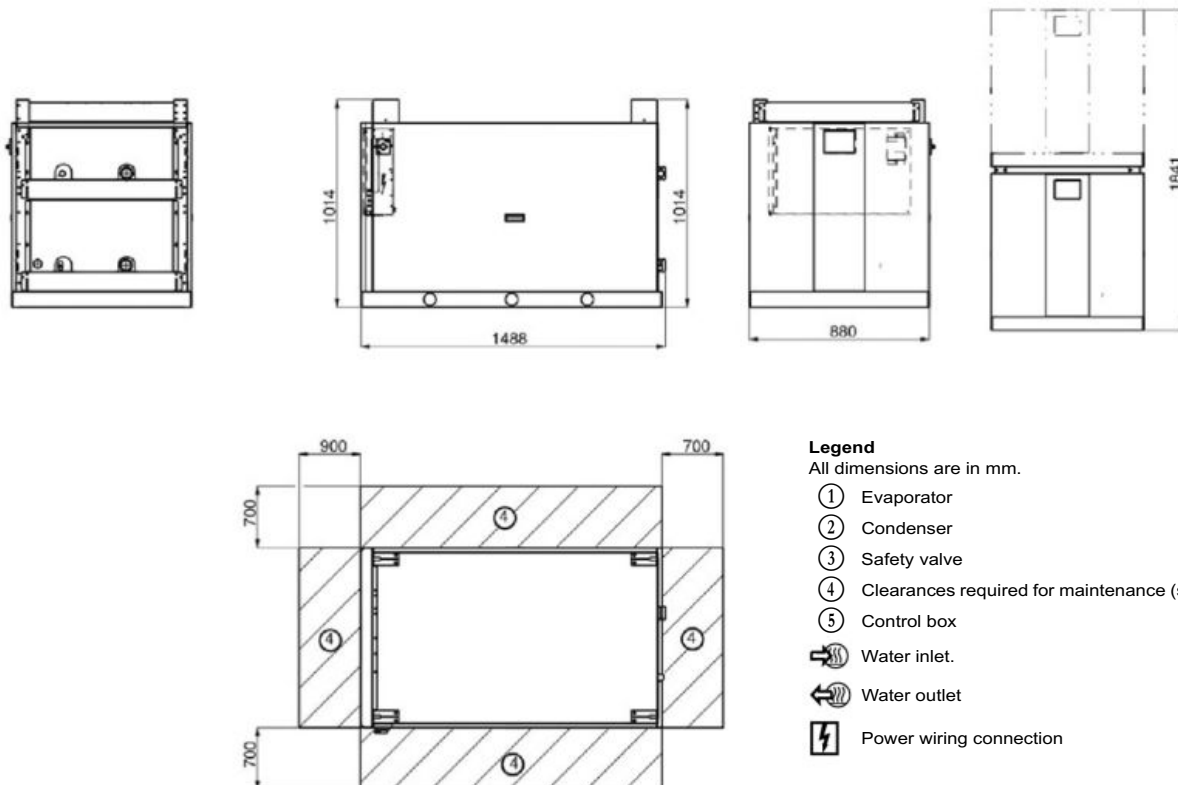

**NOTE:** Non-contractual drawings. Refer to the certified dimensional drawings available on request, when designing an installation.

## DIMENSIONS/CLEARANCES

### 30WGA 110-140 - Standard unit

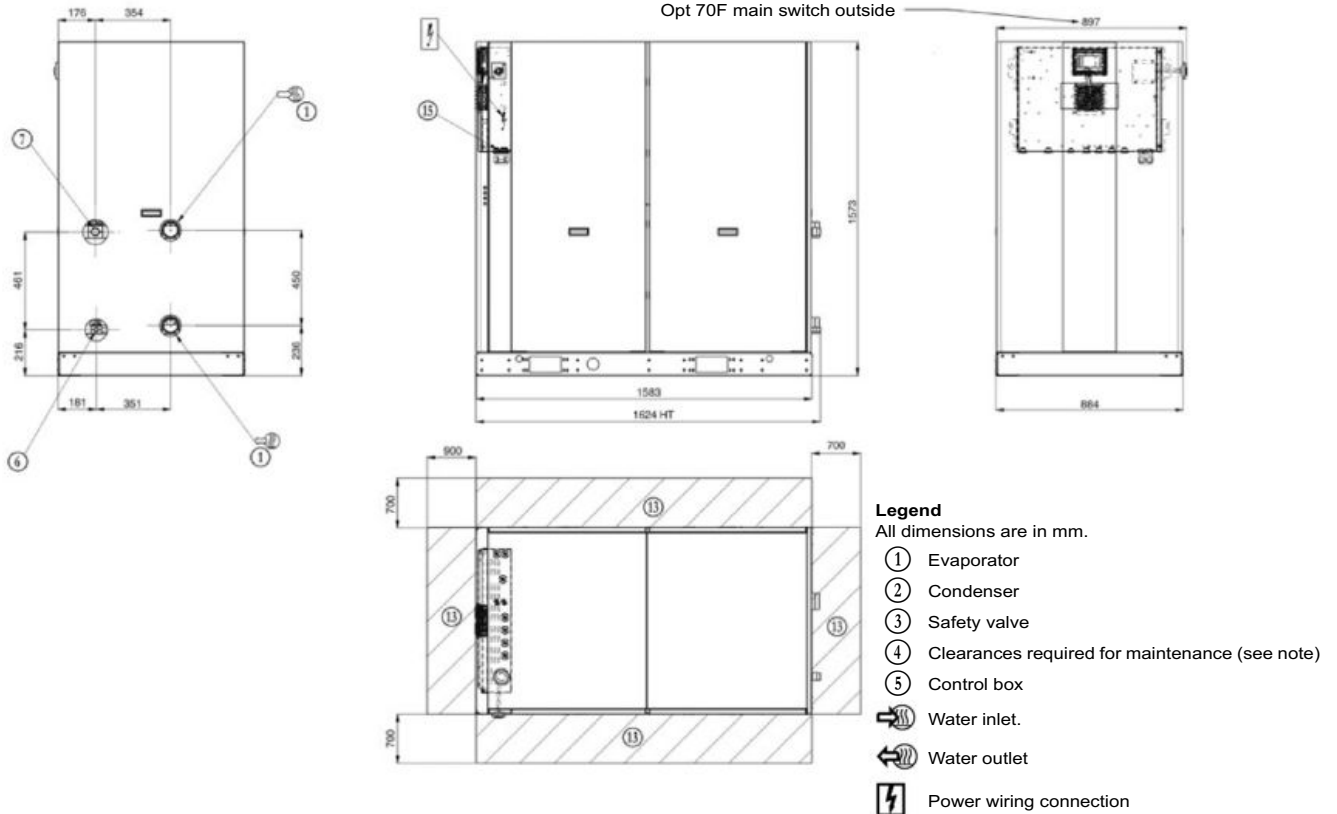

### 30WGA 110-140 - Unit with hydraulic module (option 116)

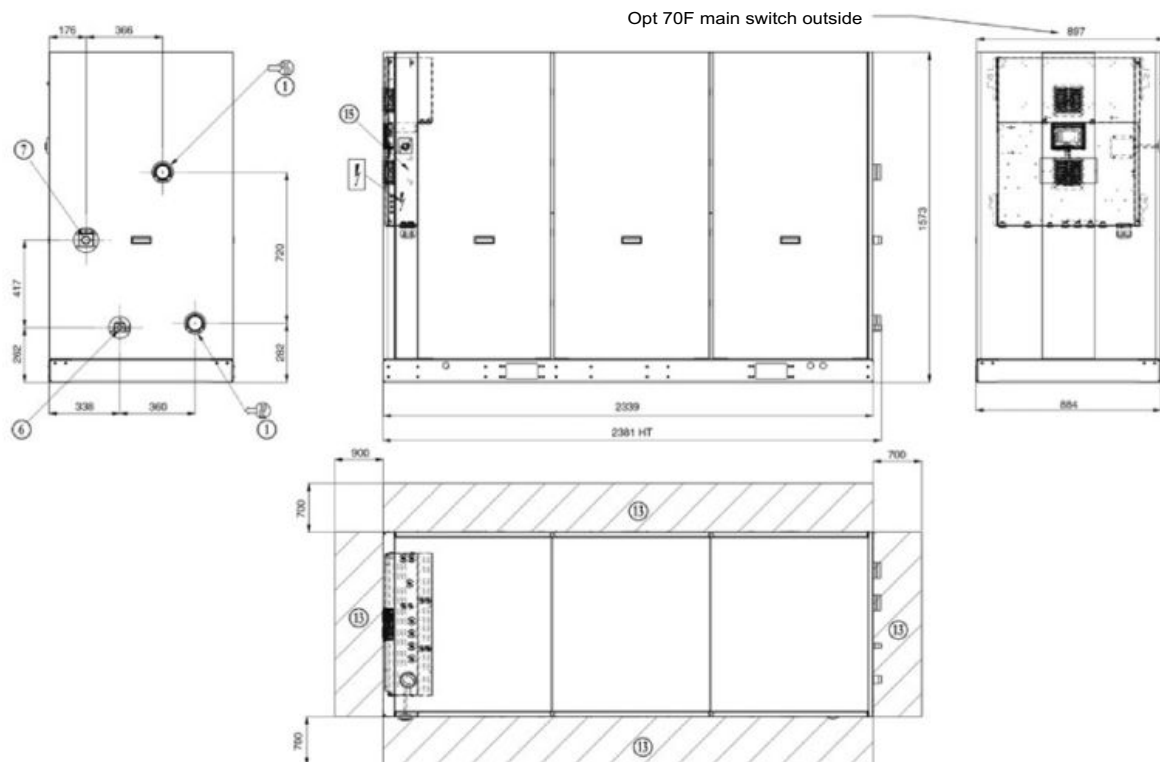

**NOTE:** Non-contractual drawings. Refer to the certified dimensional drawings available on request, when designing an installation.

## DIMENSIONS/CLEARANCES

### 30WGA 150-190 - Standard unit

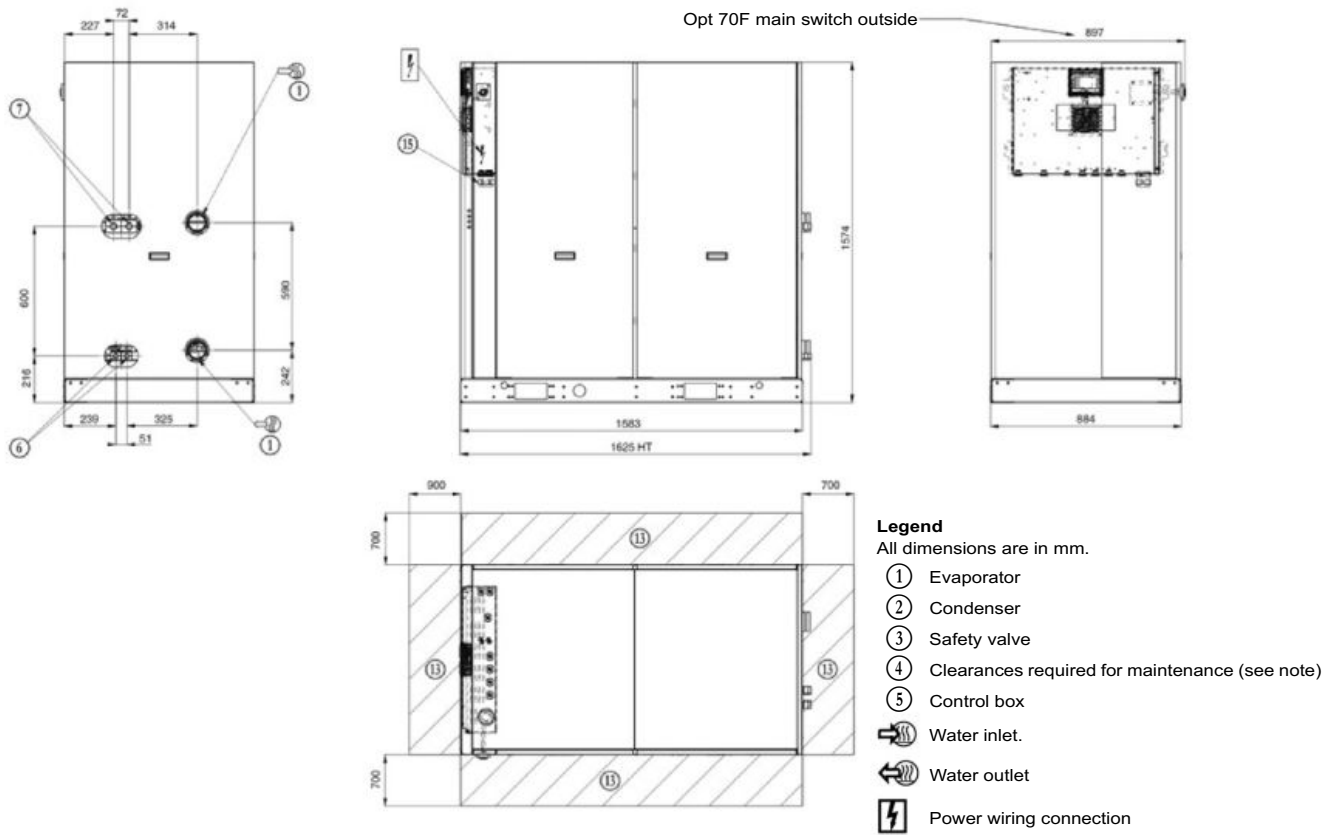

### 30WGA 150-190 - Unit with hydraulic module (option 116)

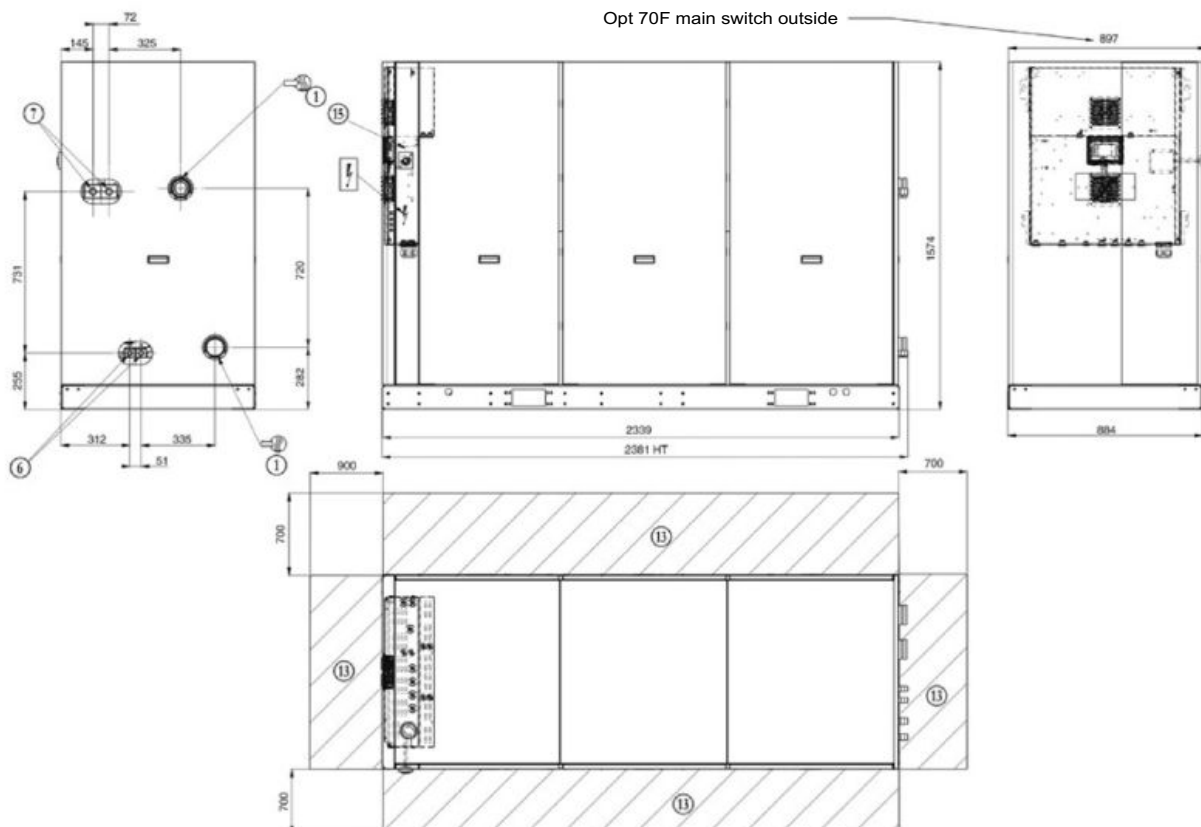

**NOTE:** Non-contractual drawings. Refer to the certified dimensional drawings available on request, when designing an installation.







## HEAT PUMPS AND LIQUID COOLERS WITH WATER COOLED CONDENSER



- Cooling and heating application
- High energy efficiency
- Compact design
- Low sound level
- Broad field of application

## 30WI 700 V - 2400 V



Cooling capacity: 200-700 kW

The new generation of AQUASNAP 30WI water cooled heat pumps and water chillers offers an optimal solution for all heating process or cooling applications.

These units are designed to be installed in machine rooms that are protected against freezing temperatures and inclement weather.

The new range has been optimised to use ozone-friendly HFC R410A refrigerant. The use of this refrigerant guarantees compliance with the most demanding requirements for environmental protection and increased seasonal energy efficiency.



CARRIER participates in the ECP programme for LCP-HP  
Check ongoing validity of certificate:  
[www.eurovent-certification.com](http://www.eurovent-certification.com)

## RANGE

---

### AQUASNAP 30WI

Cooling-only or heating-only models with water-cooled condenser.

Acoustic configuration:

- a - STANDARD version
- b - LOW NOISE version. Compressor casing
- c - VERY LOW NOISE version. Casing with compressor sound insulation

## DESCRIPTION

---

AQUASNAP series 30WI units are packaged machines supplied as standard with the following components:

- SCROLL hermetic compressors,
- Chilled water evaporator with brazed plates,
- Hot water condenser with brazed plates,
- Electrical power and remote control cabinet:
  - 400V-3ph-50Hz general electrical power supply (+10%/-10%) + earth,
  - Transformer fitted as standard on the machine for supplying the remote control circuit with 230V-1ph-50Hz,
- 30WI Control electronic control module.

The AQUASNAP 30WI range complies with the following European standards and directives:

- Machinery directive 2006/42/EC.
- Electromagnetic compatibility directive 2004/108/EC.
- EMC immunity and emissions EN 61800-3 'C3'
- Low voltage directive 2006/95/EC.
- RoHS 2011/65/EU
- Pressure equipment directive (PED) 97/23/EC
- Machinery directive EN 60-204 -1

## DESCRIPTION OF THE MAIN COMPONENTS

### ■ Compressors

- Hermetic SCROLL type.
- Built-in electric motor cooled by intake gases.
- Motor protected by internal winding thermostat.
- Placed on anti-vibration mounts.

### ■ Evaporator

- Brazed plate exchanger.
- Stainless steel plates (AISI 316).
- Plate patterns optimised for high efficiency.
- Armaflex thermal insulation.

### ■ Condenser

- Brazed plate exchanger.
- Stainless steel plates (AISI 316).
- Plate patterns optimised for high efficiency.

### ■ Refrigerating accessories

- Dehumidifier filters with rechargeable cartridges.
- Hygroscopic sight glasses.
- Solenoid valves on refrigerant lines (700 V to 1200 V models).
- Electronic expansion valves.

### ■ Control and safety instruments

- High and low pressure sensors.
- High pressure safety valves.
- Water temperature control sensors.
- Evaporator frost protection sensor.
- Factory-assembled evaporator water flow controller.

### ■ Electrical box

- IP 23.
- 400V-3Ph-50 Hz power supply + Earth (+10%/-10%).
- Main safety switch with handle on front.
- Control circuit transformer.
- Circuit breaker for compressor motor.
- Compressor motor switches.
- 30WI Control microprocessor-controlled electronic control module.
- Wire numbering.
- Marking of the main electrical components.
- RAL 7035.

### ■ 30WI Control electronic control module.

The electronic control module performs the following main functions:

- Regulation of the chilled or hot water temperature
- Regulation of the water temperature based on the outdoor temperature (water law).
- Regulation for low temperature energy storage.
- Second setpoint management.
- Complete management of compressors with start-up sequence, metering and runtime balancing.
- Self-adjusting and proactive functions with adjustment of parameters on drift control.
- In-series staged capacity-reduction system on compressors based on cooling and heating demands.
- Management of compressor short cycle protection.
- Management of the machine operation limit according to outdoor temperature.
- Operating and fault status diagnostics.
- Management of a fault memory allowing a log of the last 20 incidents to be accessed, with operating readings taken when the fault occurs.
- Master/slave management of the two machines in parallel with runtime balancing and automatic changeover if a fault occurs on one machine.
- Machine time schedule.
- Display and access to the operating parameters via a multilingual LCD screen with 4 lines of 24 characters.

### ■ Remote management

30WI Control is equipped as standard with an RS485 serial port offering a range of remote management, monitoring and diagnostic options via the communication bus.

Several contacts are available as standard, enabling the AQUASNAP 30WI to be controlled remotely by wired link:

- Automatic operation control: when this contact is open, the machine stops.
- Setpoint 1/setpoint 2 selector: when this contact is closed, a second cooling setpoint is activated (energy storage mode, for example).
- Heating/cooling mode selector: this input switches from one operating mode to another. Contact closed = heating mode.

Contact open = cooling mode.

- Setpoint adjustable via 4-20 mA signal: this input is used to adjust the setpoint in heating or cooling mode.
- Compressor load shedding: closing the contact(s) concerned allows the power or refrigerating consumption of the machine to be limited by stopping one or more compressors.
- Water pump 1 and 2 control: these outputs control the switches for one or two water pumps.
- Fault reporting: this contact indicates the presence of a major fault which has caused one or both refrigerating circuits to stop.

### ■ Capacity control

In-series staged power control system on the compressors:

- 4 stages for 700 V to 1600 V models.
- 6 stages for 1800 V and 2400 V models.
- 8 stages for 2100 V models.

### ■ Casing

Casing made from RAL 7035 painted panels.

## OPTIONS

Options	No.	Description	Advantages	Use
Soft Starter	25	Electronic starter on each compressor	Reduced start-up current	0700-2400
Master/slave operation	58	Unit equipped with supplementary water outlet temperature sensor kit to be fieldinstalled allowing master/slave operation of two units connected in parallel	Optimised operation of two units connected in parrallele operation with operating time equalisation	0700-2400
Condenser insulation	86	Thermal condenser insulation	Minimizes thermal dispersions condenser side (key option for heat pump or heat recovery applications) and allows compliancy with special installation criteria (hot parts insulated)	0700-2400
Compressor suction valve	92	Valve installed on the compressor suction side to isolate it in the refrigerant circuit	Simplified service and maintenance	0700-2400
Lon gateway	148D	Two-directional communication board complying with Lon Talk protocol	Connects the unit by communication bus to a building management system	0700-2400
Bacnet over IP	149	Two-directional high-speed communication using BACnet protocol over Ethernet network (IP)	Easy and high-speed connection by ethernet line to a building management system. Allows access to multiple unit parameters	0700-2400
Dry contact board	156C	Feedback board on the potential-free contact for the main statuses and faults	Simple feedback of the diagnostics and unit state	0700-2400
Phase controller	159B	Phase controller on the power	Reinforced protection of the compressors by monitoring rotation, the absence and asymmetry of the phases, and the over- or under-voltage of the electricity network	0700-2400
Compliance with Russian regulations	199	EAC certification	Conformance with Russian regulations	0700-2400
Low noise level	257	Compressor sound enclosure	Reduced sound emissions	0700-2400
Very low sound level	258	Enhanced sound insulation of main noise sources (Material classified CD0S2 fire class according to Euroclass 13-501).	6 dB(A) quieter than standard . Refer to the physical data table for detailed values	0700-2400
Welded evaporator connection kit	266	Victaulic piping connections with welded joints	Easy installation	0700-2400
Welded condenser water connection kit	267	Victaulic piping connections with welded joints	Easy installation	0700-2400
Electric energy meter	294	MID certified electric energy meter (compliant with directive 2004/22/EC). Display of energy consumption, instantaneous (U, V, I) and cumulative (kWh), on the SmartVu™ interface	Permits the acquisition, (remote) monitoring and billing of energy used.	0700-2400
External temperature sensor	312	External temperature sensor control for using weather compensation	Allow to adjust set point using weather compensation and define autorisation operation mode to external temperature	0700-2400
Compliance with Morocco regulation	327	Specifics documents according Morroco regulation	Conformance with Morocco regulations	0700-2400

## TECHNICAL SPECIFICATIONS

30WI			700 V	800 V	900 V	1000 V	1100 V	1200 V	
<b>Heating</b>									
Standard unit Seasonal energy efficiency**	HA1	SCOP <sub>30/35°C</sub>	kW / kW	5,30	5,53	5,45	5,47	5,43	5,49
		η <sub>s heat</sub> <sub>30/35°C</sub>	%	204	213	210	211	209	212
		P <sub>rated</sub>	kW	246	293	335	384	419	463
<b>Cooling</b>									
Standard unit Full load performances*	CA1	Net cooling capacity	kW	203	242	278	320	348	382
		Net power input	kW	49	56	64	71	79	86
		EER	kW / kW	4,18	4,32	4,33	4,5	4,42	4,42
Standard unit Seasonal energy efficiency**		SEPR <sub>-2/-8°C</sub>	kWh/kWh	3,04	3,08	3,09	3,04	3,08	3,11
		Process medium temp ***							
Standard unit Seasonal energy efficiency**		SEER <sub>12/7°C</sub>	kW / kW	4,66	4,96	4,92	4,96	4,91	4,92
		Comfort Low temp.							
Standard unit		Lw / Lp <sup>(1)</sup>	dB(A)	89/57	90/58	90/58	89/57	90/58	91/59
Unit + Low Noise option		Lw / Lp <sup>(1)</sup>	dB(A)	84/52	85/53	85/53	86/54	87/55	88/56
Unit + Xtra Low Noise		Lw / Lp <sup>(1)</sup>	dB(A)	79/47	80/48	80/48	80/48	81/49	82/50
<b>Refrigerating circuit</b>									
Refrigerant (GWP)	R410 (GWP=2088)								
Number	2								
Refrigerant circuit 1	kg	13,5	15,5	16,4	17	19,7	21,3		
Refrigerant circuit 2	kg	14	15	16,4	17,2	19,7	21,3		
Tonne of CO <sub>2</sub> equivalent	TCO <sub>2</sub> Eq	57,42	63,68	68,49	71,41	82,27	88,95		
<b>Compressor</b>									
Type	Hermetic scroll (- 2900 rpm)								
Number	4	4	4	4	4	4	4		
Start-up mode	Direct in line in series								
Capacity control	Number of stages	6	4	6	4	6	4		
	%	100-78-71-50-28-21-0	100-75-50-25-0	100-78-71-50-28-21-0	100-75-50-25-0	100-78-71-50-28-21-0	100-75-50-25-0		
Type of oil for R410A	Polyolester POE								
Oil load per circuit	l	6,7+6,7	6,7+6,7	6,7+6,7	6,7+6,7	6,7+7,2	7,2+7,2		
<b>Evaporator</b>									
Type/ Number	Braze-plate heat exchanger/1								
Water capacity	l	20	23	26	29	32	37		
Victaulic connection	Ø	DN100	DN100	DN100	DN125	DN125	DN125		
Max. pressure, water end	bar	10 bar							
Min/max water flow	m <sup>3</sup> /h	22/70	26/81	29/92	33/105	35/113	38/124		
<b>Water-cooled condenser</b>									
Type/ Number	Braze-plate heat exchanger/1								
Water capacity	l	23	26	29	32	37	40		
Victaulic connection	Ø	DN100	DN100	DN100	DN125	DN125	DN125		
Max. pressure, water end	bar	10 bar							
Min/max water flow	m <sup>3</sup> /h	19/64	22/74	25/84	28/95	31/103	33/112		
<b>Dimensions</b>									
Length	mm	2099	2099	2099	2099	2099	2099		
Width	mm	996							
Height	mm	1869	1869	1869	1869	1869	1869		
<b>Weight</b>									
Weight (empty)	kg	1044	1156	1189	1312	1363	1425		
Weight in operation	kg	1088	1205	1246	1378	1436	1510		
Max. storage temperature	°C	+50°C							

Outputs in accordance with EUROVENT standard EN 14511 conditions

\* In accordance with standard EN14511-3:2022.

\*\* In accordance with standard EN14825:2022, average climate

\*\*\* With EG 30%.

HA1 Heating mode conditions: Water heat exchanger water entering/leaving temperature 30°C/35°C, outside air temperature tdb/twb = 7°C db/6°C wb, evaporator fouling factor 0 m<sup>2</sup>. kW.

CA1 Cooling mode conditions: evaporator water inlet/outlet temperature 12 °C/7 °C, outdoor air temperature 35 °C, evaporator fouling factor 0 m<sup>2</sup>. kW

η<sub>s heat</sub><sub>30/35°C</sub> & SCOP<sub>30/35°C</sub> Values in bold comply with Ecodesign Regulation (EU) No. 813/2013 for Heating applications.

SEER<sub>12/7°C</sub> Values calculated according to EN14825:2022.

SEPR<sub>-2/-8°C</sub> Values in bold comply with Ecodesign Regulation (EU) No. 2015/1095 for Process application

(1) Lw : overall power level in accordance with standard ISO3744

Lp : overall pressure level at 10 metres in a free field calculated using the formula Lp=LW-10logS



Eurovent certified values



## TECHNICAL SPECIFICATIONS

30WI			1400 V	1600 V	1800 V	2100 V	2400 V	
<b>Heating</b>								
<b>Standard unit</b>	HA1	<b>SCOP</b> <sub>30/35°C</sub>	<b>kW / kW</b>	<b>5,49</b>	<b>5,48</b>	<b>5,44</b>	<b>5,46</b>	<b>5,24</b>
Seasonal energy efficiency**		<b>η<sub>s heat</sub></b> <sub>30/35°C</sub>	<b>%</b>	<b>212</b>	<b>211</b>	<b>210</b>	<b>211</b>	<b>202</b>
		<b>P<sub>rated</sub></b>	<b>kW</b>	<b>530</b>	<b>593</b>	<b>687</b>	<b>795</b>	<b>876</b>
<b>Cooling</b>								
<b>Standard unit</b>	CA1	Net cooling capacity	kW	439	495	574	651	703
Full load performances*		Net power input	kW	97	108	125	145	165
		EER	kW / kW	4,55	4,6	4,6	4,49	4,27
<b>Standard unit</b>		<b>SEPR</b> <sub>-2/-8°C</sub>	<b>kWh/kWh</b>	<b>3,21</b>	<b>3,31</b>	<b>3,26</b>	<b>3,33</b>	<b>3,37</b>
Seasonal energy efficiency**		<b>Process medium temp</b> ***						
<b>Standard unit</b>		SEER <sub>12/7°C</sub>	kW / kW	4,98	4,97	4,99	4,89	4,60
Seasonal energy efficiency**		Comfort Low temp.						
Standard unit		Lw / Lp <sup>(1)</sup>	dB(A)	95/63	96/64	93/61	95/63	97/65
Unit + Low Noise option		Lw / Lp <sup>(1)</sup>	dB(A)	90/58	91/59	89/57	90/58	91/59
Unit + Xtra Low Noise		Lw / Lp <sup>(1)</sup>	dB(A)	85/53	86/54	85/53	86/54	87/55
<b>Refrigerating circuit</b>								
Refrigerant (GWP)		R410 (GWP=2088)						
Number		2						
Refrigerant circuit 1		kg	21,5	23	31	33	34	
Refrigerant circuit 2		kg	21	22	31	34	34	
Tonne of CO <sub>2</sub> , equivalent		TCO <sub>2</sub> Eq	88,74	93,96	129,46	139,9	141,98	
<b>Compressor</b>								
Type		Hermetic scroll (- 2900 rpm)						
Number			4	4	6	6	6	
Start-up mode		Direct in line in series						
		Number of stages	6	4	6	8	6	
Capacity control		%	100-78-71-50-28-21-0	100-75-50-25-0	100-83-66-50-33-16-0	100-84-66-48-36-30-18-15-0	100-83-66-50-33-16-0	
Type of oil for R410A		Polyolester POE						
Oil load per circuit		l	6,3+6,3	6,3+6,3	3x6,3	3x6,3	3x6,3	
<b>Evaporator</b>								
Type/ Number		Brazen-plate heat exchanger						
Water capacity		l	50	57	64	77	77	
Victaulic connection		Ø	DN125	DN125	DN150	DN150	DN150	
Max. pressure, water end		bar	10 bar					
Min/max water flow		m <sup>3</sup> /h	44/137	51/151	61/150	68/150	74/150	
<b>Water-cooled condenser</b>								
Type/ Number		Brazen-plate heat exchanger						
Water capacity		l	55	61	73	77	77	
Victaulic connection		Ø	DN125	DN125	DN150	DN150	DN150	
Max. pressure, water end		bar	10 bar					
Min/max water flow		m <sup>3</sup> /h	38/129	43/143	52/150	59/150	66/163	
<b>Dimensions</b>								
Length		mm	2499	2499	3350	3350	3350	
Width		mm	996					
Height		mm	1887	1887	1970	1970	1970	
<b>Weight</b>								
Weight (empty)		kg	1613	1708	2284	2376	2418	
Weight in operation		kg	1713	1818	2472	2588	2637	
<b>Max. storage temperature</b>		°C	+50°C					

Outputs in accordance with EUROVENT standard EN 14511 conditions

\* In accordance with standard EN14511-3:2022.

\*\* In accordance with standard EN14825:2022, average climate

\*\*\* With EG 30%.

HA1 Heating mode conditions: Water heat exchanger water entering/leaving temperature 30°C/35°C, outside air temperature tdb/twb = 7°C db/6°C wb, evaporator fouling factor 0 m<sup>2</sup>. kW.

CA1 Cooling mode conditions: evaporator water inlet/outlet temperature 12 °C/7 °C, outdoor air temperature 35 °C, evaporator fouling factor 0 m<sup>2</sup>. kW

**η<sub>s heat</sub>**<sub>30/35°C</sub> & **SCOP**<sub>30/35°C</sub> **Values in bold comply with Ecodesign Regulation (EU) No. 813/2013 for Heating applications.**

SEER<sub>12/7°C</sub> Values calculated according to EN14825:2022.

**SEPR**<sub>-2/-8°C</sub> **Values in bold comply with Ecodesign Regulation (EU) No. 2015/1095 for Process application**

(1) **Lw** : overall power level in accordance with standard ISO3744

**Lp** : overall pressure level at 10 metres in a free field calculated using the formula Lp=LW-10logS



Eurovent certified values

## ELECTRICAL SPECIFICATIONS

30WI	700 V	800 V	900 V	1000 V	1100 V	1200 V	1400 V	1600 V	1800 V	2100 V	2400 V
------	-------	-------	-------	--------	--------	--------	--------	--------	--------	--------	--------

### COMPRESSOR

Voltage	V	400V - 3Ph - 50Hz (+10/- 10%)										
Maximum nominal current	A	140	160	182	205	218	232	266	295	356	399	443
Starting current <sup>(1)</sup>	A	316	334	391	414	480	494	586	615	607	720	763
Starting current with Soft Start option <sup>(1)</sup>	A	230	248	287	310	352	366	429	458	483	562	605

### REMOTE CONTROL AUXILIARY CIRCUIT

Voltage	V	230V - 1Ph - 50Hz (+10/- 10%)										
Maximum nominal current	A	0,8	0,8	0,8	0,8	0,8	0,8	1,3	1,3	1,3	1,3	1,3
Transformer capacity	VA	160	160	160	160	160	160	250	250	250	250	250
Machine protection rating		IP 21										

- (1) Starting current of largest compressor + maximum current of other compressors under full load  
 Cable selection nominal current = sum of maximum nominal currents in above tables

## DIMENSIONS

### 700 V to 1600 V models

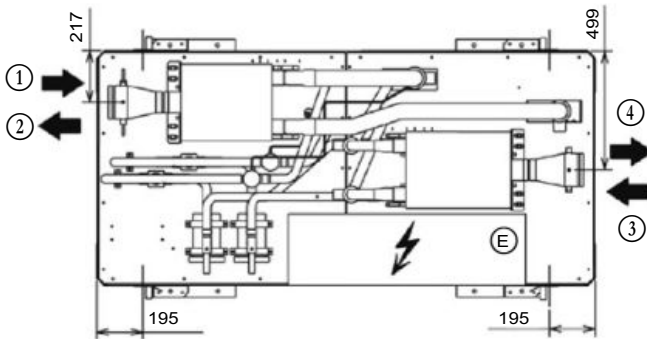
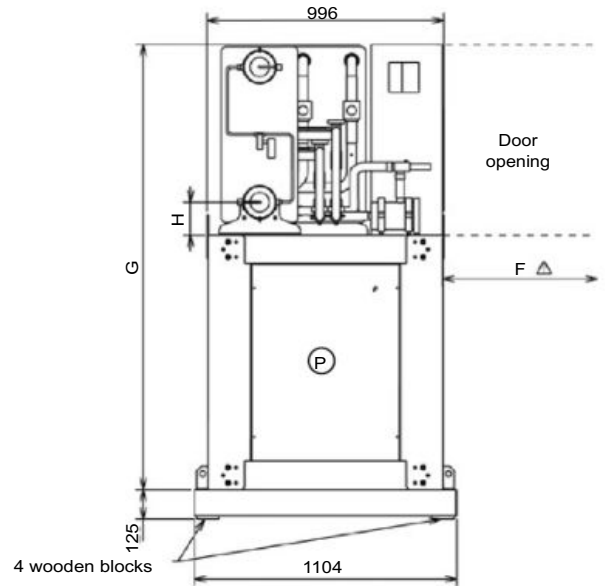
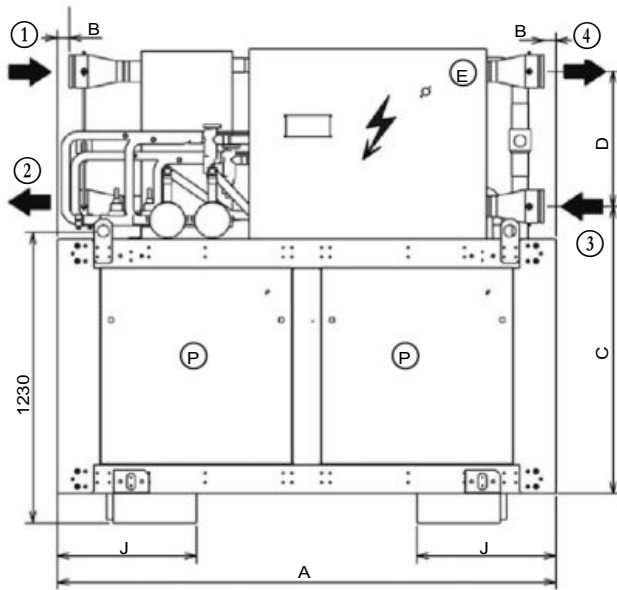

- Ⓔ Electrical connection on the side
- Ⓕ Noise insulation panels option

Models	Dimensions (mm)								Chilled water		Hot water		Weight (kg)	
	A	B	C	D	F	G	H	J	Inlet 1	Outlet 2	Inlet 3	Outlet 4	Empty	In operation
700 V	2099	49	1207	568	1000	1869	137	585	VICTAULIC DN 100				1044	1088
800 V	2099	49	1207	568	1000	1869	137	585					1156	1205
900 V	2099	49	1207	568	1000	1869	137	585					1189	1246
1000 V	2099	49	1207	568	1000	1869	137	585	VICTAULIC DN 125				1312	1378
1100 V	2099	49	1207	568	1000	1869	137	585					1363	1436
1200 V	2099	49	1207	568	1000	1869	137	585					1425	1510
1400 V	2499	60	1240	532	600	1887	170	715					1613	1713
1600 V	2499	60	1240	532	600	1887	170	715					1708	1818

## DIMENSIONS

### 1800 V to 2400 V models

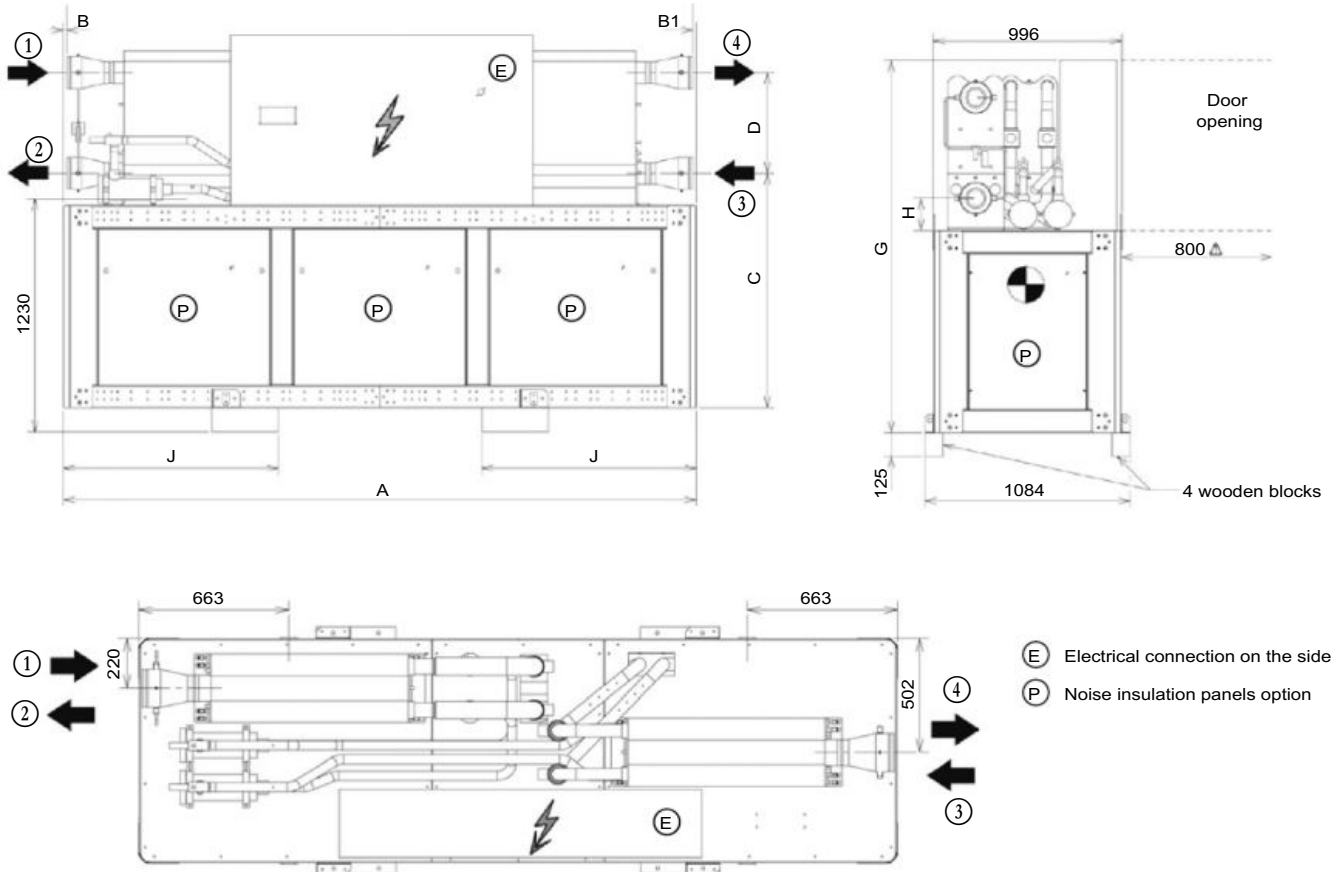

Models	Dimensions (mm)								Chilled water		Hot water		Weight (kg)	
	A	B	B1	C	D	G	H	J	Inlet 1	Outlet 2	Inlet 1	Outlet 2	Empty	In operation
1800 V	3350	63	63	1240	532	1970	170	1135	VICTAULIC DN 150				2284	2472
2100 V	3350	15	15	1240	532	1970	170	1135					2376	2588
2400 V	3350	15	15	1240	532	1970	170	1135					2418	2637





## WATER-COOLED SCREW CHILLERS



- Low energy consumption
- High reliability
- Safe Design
- Easy and fast installation
- Minimised operating sound levels
- Environmental care

## 30XW-PZE

Nominal cooling capacity 271-1110 kW

The 30XW-PZE liquid chillers are the premium solution for industrial and commercial applications where installers, consultants and building owners require optimal performances and maximum quality.

The 30XW-PZE liquid chillers are designed to meet current and future requirements in terms of energy efficiency, flexibility of use and compactness. They use the most reliable technologies available today:

- Twin-rotor screw compressors with a variable capacity valve
- R-1234ze refrigerant or R-515B
- Flooded heat exchangers that are mechanically cleanable
- Carrier SmartVu™ control with color touch screen user interface that includes 10 languages

The AquaForce PUREtec range is splitted into two versions:

- 30XW-PZE for air conditioning and refrigeration applications
- 30XWHPZE for heating applications

As standard, the unit can provide an evaporator leaving temperature down to 3,3°C, and when operating as a heat pump, it can deliver up to 55°C (70°C optional) on the condenser side.



CARRIER participates in the ECP programme for LCP-HP  
Check ongoing validity of certificate:  
[www.eurovent-certification.com](http://www.eurovent-certification.com)

## CUSTOMER BENEFITS

### Low energy consumption

- 30XW-PZE range is compliant with EU Eco-design Minimum Efficiency Performance Standards (MEPS) in cooling that apply from January 2021
- SEER 12/7°C up to 7.6 and SEPR 12/7°C up to 9.3
- 30XWHPZE range is compliant with EU Eco-design Minimum Efficiency Performance Standards (MEPS) in heating that apply from September 2015
- COP of up to 6.7 and SCOP up to 7.2
- The high energy efficiency is reached through:
  - Twin-rotor screw compressor equipped with a high-efficiency motor and a variable capacity valve that permits exact matching of the cooling capacity to the load.
  - Flooded multi-pipe heat exchangers for increased heat exchange efficiency.
  - Electronic expansion device permitting operation at a lower condensing pressure and improved utilisation of the evaporator heat exchange surface.
  - Economizer system with electronic expansion device for increased cooling capacity.

### Low operating sound levels

- Standard unit features include:
  - Silencers on the compressors discharge line.
  - Silencers on the economiser return line.
  - Acoustic insulation on the components that are most subjected to radiated noise.
  - Option 257 further reduces the global unit sound level.

### Easy and fast installation

- Compact design
  - The 30XW units are designed to offer the most compact dimensions on the market.
  - With a width of approximately 1 m up to 1300 kW the units can pass through standard door openings and only require minimum floor space in the plant room.

### Compact, accessible unit - side view - sizes up to 1300 KW

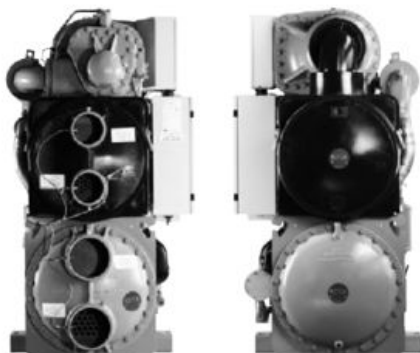

- Simplified electrical connections
  - Main disconnect switch with high trip capacity
  - Transformer to supply the integrated control circuit (400/24 V)
- Simplified hydraulic connections
  - Victaulic connections on the evaporator and condenser
  - Practical reference marks for entering and leaving water connections
  - Possibility to reverse the heat exchanger water inlet and outlet at the factory
  - Possibility to modify the number of heat exchanger passes
- Fast commissioning
  - Systematic factory operation test before shipment
  - Quick-test function for step-by-step verification of the instruments, expansion devices and compressors.

### Environmental care



- R-1234ze long-term refrigerant solution
  - HFO refrigerant with nearly zero global warming potential (GWP < 1) and zero ozone depletion potential (ODP = 0).
  - Not impacted by the HFC phase-down plan in Europe (79% HFC reduction in EU member states at 2030 horizon)
  - Compliant with refrigerant regulation in Switzerland that bans the use of HFC refrigerant in large capacity air-conditioning equipment.
- Leak-tight refrigerant circuit
  - Reduction of leaks as no capillary tubes and flare connections are used
  - Verification of pressure transducers and temperature sensors without transferring refrigerant charge
  - Discharge line shut-off valve and liquid line service valve for simplified maintenance.

### High reliability and easy servicing

- The 30XW units offer increased global performance as well as Carrier's acclaimed product quality and reliability.
- Major components are selected and tested with R-1234ze and R-515B refrigerant to minimize failures possibility, as well as many design choices have been taken in this perspective.
- Non flammable use possible when selecting option 330, Low GWP A1 R-515 Refrigerant
- Screw compressors
  - Industrial-type screw compressors with oversized bearings and motor cooled by suction gas.
  - All compressor components are easily accessible on site minimising down-time.
- Refrigerant circuit
  - Two independent refrigerant circuits (from 1000 kW upwards); the second one automatically takes over, if the first one develops a fault, maintaining partial cooling under all circumstances.
- Evaporator
  - Electronic paddle-free flow switch. Auto-setting according to cooler size and fluid type.
- Auto-adaptive control
  - Control algorithm prevents excessive compressor cycling (Carrier patent)
  - Automatic compressor unloading in case of abnormally high condensing pressure.
- Exceptional endurance tests
  - Partnerships with specialised laboratories and use of limit simulation tools (finite element calculation) for the design of critical components.
  - Transport simulation test in the laboratory on a vibrating table and then on an endurance circuit (based on a military standard).

## CUSTOMER BENEFITS

### Safe Design

- Specific polyol ester oil qualified by Carrier for using with HFO-1234ze or R-515B to guarantee and maintain reliable bearing lubrication.
- Specific compressor gaskets compatible with HFO-1234ze or R-515B, tested and validated by Carrier.
- New relief valves designed for operation with HFO-1234ze or R-515B
- Specific electrical box with increased tightness and integrated blower that maintains positive air pressure to avoid any risk of ignition when using R-1234ze refrigerant.
- No need of ducted electrical cabinet fresh air supply when using option 330 - LOW GWP A1 R-515B refrigerant
- New control algorithms
- Specific documentation that contains all the installation, operation, maintenance and safety Instructions.

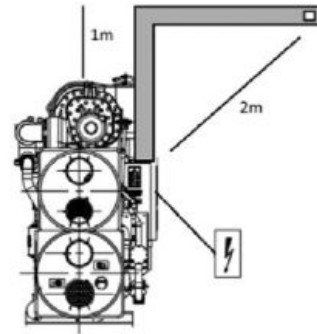

## TECHNICAL INSIGHTS

### SmartVu™ Control

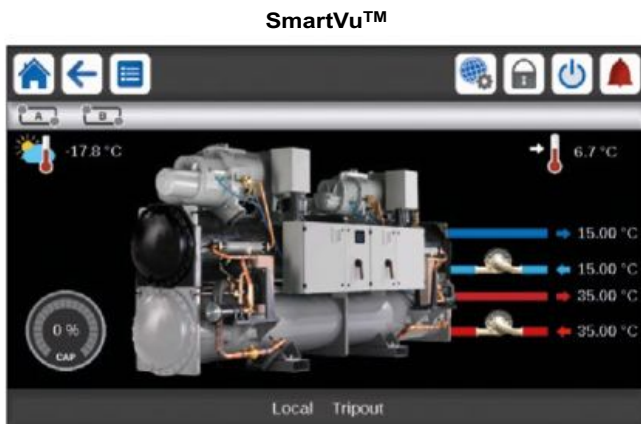

- New innovative smart control features:
  - An intuitive and user-friendly, coloured, 7" interface
  - 10 languages available on choice: DE, EN, ES, FR, IT, NL, PT, TR, TU + one additional customer choice
  - Screen-shots with concise and clear information in local languages
  - Complete menu, customised for different users (end user, service personnel and Carrier-factory technicians)
  - Setpoint offset based on the outside air temperature
  - Safe operation and unit setting: Password protection ensures that unauthorised people cannot modify any advanced parameters
  - Simple and "smart" intelligence uses data collection from the constant monitoring of all machine parameters to optimise unit operation
  - Night-mode: Cooling capacity management for reduced noise level.
  - With hydraulic module: Water pressure display and water flow rate calculation
- Energy management:
  - Internal time schedule clock controls chiller on/off times and operation at a second set-point
  - The DCT (Data Collection Tool) records the alarms history to simplify and facilitate service operations.

- Maintenance functions
  - F-Gas regulation leak check reminder alert
  - aintenance alert can be configured to days, months or hours of operation
- Advanced communication features
  - Easy and high-speed communication technology over Ethernet (IP) to a centralised building management system
  - Access to multiple unit parameters

### Remote Management (Standard)

- Units with SmartVu™ control can be easily accessed from the internet, using a PC with an Ethernet connection. This makes remote control quick and easy and offers significant advantages for service operations.
- Aquaforce with Greenspeed® Intelligence is equipped with an RS485 serial port that offers multiple remote control, monitoring and diagnostic possibilities. When networked with other Carrier equipment through the CCN (Carrier Comfort Network - proprietary protocol), all components form a HVAC system fully-integrated and balanced through one of the Carrier's network system products, like the Chiller System anager or the Plant System anager (optional)
- The 30XWZE/30XWPZE also communicates with other building management systems via optional communication gateways (BACnet, LON or JBus).
- The following commands/visualisations are possible from remote connection:
  - Start/Stop of the machine
  - Dual set-point management: Through a dedicated contact is possible to activate a second set-point (example, unoccupied mode)
  - Demand limit setting: To limit the maximum chiller capacity to a predefined value
  - Water pump control: These outputs control the contactors of one/two evaporator water pumps.
  - Water pumps changeover (only with hydraulic module options): These contacts are used to detect a water pump operation fault and automatically change over to the other pump.
  - Operation visualisation: ndication if the unit is operating or if it is in stand-by (no cooling load).
  - Alarm visualisation.

## TECHNICAL INSIGHTS

### Remote management (EMM option)

- The Energy management module (EMM) offers extended remote control possibilities:
- Room temperature: Permits set-point reset based on the building indoor air temperature (if Carrier thermostats are installed)
- Set-point reset: Allows reset of the cooling set-point based on a 4-20 mA or 0-10 V signal
- Demand limit: Permits limitation of the maximum chiller capacity based on 0-10 V signal
- Demand limit 1 and 2: Closing of these contacts limits the maximum chiller capacity to two predefined values.
- User safety: This contact can be used for any customer safety loop; opening the contact generates a specific alarm.
- Ice storage end: When ice storage has finished, this input permits return to the second set-point (unoccupied mode).
- Time schedule override: Closing of this contact cancels the programmed time schedule.
- Out of service: This signal indicates that the chiller is completely out of service.
- Chiller capacity: This analogue output (0-10 V) gives an immediate indication of the chiller capacity.
- Alert indication: This volt-free contact indicates the necessity to carry out a maintenance operation or the presence of a minor fault.
- Compressors running status: Set of outputs (as many as the compressors number) indicating which compressors are running

### 06T screw compressor

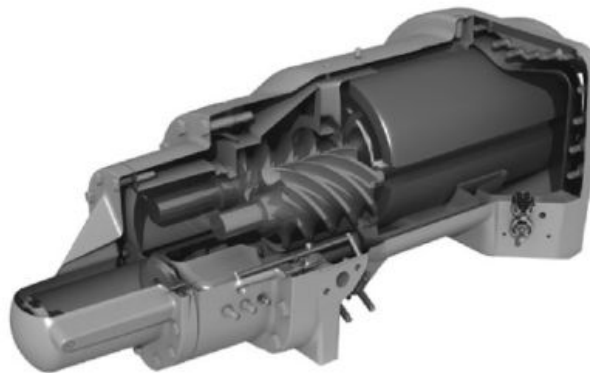

The Carrier 06T screw compressor designed for operation with HFO-1234ze and R-515B refrigerant benefits from Carrier's long experience in the development of twin-rotor screw compressors. The compressor is equipped with bearings with oversized rollers, oil pressure lubricated for reliable and durable operation, even at maximum load.

A variable control valve controlled by the oil pressure permits infinitely variable cooling capacity. This system allows optimal adjustment of the compressor cooling capacity and ensures exceptionally high stability of the chilled water leaving temperature.

Among the other advantages: if a fault occurs e.g. if the condenser is fouled or at very high water temperature, the compressor does not switch off, but continues operation with a reduced capacity (unloaded mode).

The silencer in the discharge line considerably reduces discharge gas pulsations for much quieter operation.

The condenser includes an oil separator that minimises the amount of oil in circulation in the refrigerant circuit and re-directs it to the compressor function.

### Digit number

1	2	3	4	5	6	7	8	9	1	1	1	1	1	1	1	1	1
3	0	X	W	-	P	Z	E	0	3	0	1	B	0	0	0	1	-

**Legend :**

- Digit 1 to 4 : Water-cooled chiller with screw compressor
- Digit 5 : Application type, - = Cooling, H = Heating
- Digit 6 : Efficiency, - = standard, P = premium
- Digit 7 & 8 : Unit using R1234ze refrigerant
- Digit 9 to 12 : Model number based on cooling capacity in kW
- Digit 13 : Index for major product modification (visible impact for customer)
- Digit 14 to 17 : Counter used to generate a one time product code
- Digit 18 : Not used



OPTIONS

Options	N°	Description	Advantages	Use
Light-brine solution, down to -3°C	8	Implementation of new algorithms of control to allow chilled brine solution production down to -3°C when ethylene glycol is used (0°C with propylene glycol)	Matches with most application requirements for ground-sourced heat pumps and fits with many industrial processes requirements	301-1101
Master/slave operation	58	Unit equipped with supplementary water outlet temperature sensor kit to be field-installed allowing master/slave operation of two units connected in parallel	Optimised operation of two units connected in parrallele operation with operating time equalisation	301-1101
Single power connection point	81	Unit power connection via one main supply connection	Quick and easy installation	801-1101
Evap. pump power/control circuit	84	Unit equipped with an electrical power and control circuit for one pump evaporator side	Quick and easy installation: the control of fixed speed pumps is embedded in the unit control	301-1001
Evap. dual pumps power/control circuit	84D	Unit equipped with an electrical power and control circuit for two pumps evaporator side	Quick and easy installation: the control of fixed speed pumps is embedded in the unit control	301-1001
Cond. pump power/control circuit	84R	Unit equipped with an electrical power and control circuit for one pump condenser side	Quick and easy installation: the control of fixed speed pumps is embedded in the unit control	301-1001
Condenser insulation	86	Thermal condenser insulation	Minimizes thermal dispersions condenser side (key option for heat pump or heat recovery applications) and allows compliancy with special installation criteria (hot parts insulated)	301-1101
Service valve set	92	Liquid line valve (evaporator inlet) and compressor suction line valve	Allow isolation of various refrigerant circuit components for simplified service and maintenance	301-1101
Evaporator with one pass less	100C	Evaporator with one pass on the water side. Evaporator inlet and outlet on opposite sides.	Easy to install, depending on site. Reduced pressure drops	301-1101
Condenser with one pass less	102C	Condenser with one pass on the water side. Condenser inlet and outlet on opposite sides.	Easy to install, depending on site. Reduced pressure drops	301-1101
21 bar evaporator	104	Reinforced evaporator for extension of the maximum water-side service pressure to 21 bar (standard 10 bar)	Covers applications with a high water column evaporator side (typically high buildings)	301-1101
21 bar condenser	104A	Reinforced condenser for extension of the maximum water-side service pressure to 21 bar (standard 10 bar)	Covers applications with a high water column condenser side (typically high buildings)	301-1101
Reversed evaporator water connections	107	Evaporator with reversed water inlet/outlet	Easy installation on sites with specific requirements	301-1101
Reversed condenser water connections	107A	Condenser with reversed water inlet/outlet	Easy installation on sites with specific requirements	301-1101
Lon gateway	148D	Two-directional communication board complying with Lon Talk protocol	Connects the unit by communication bus to a building management system	301-1101
Bacnet over IP	149	Two-directional high-speed communication using BACnet protocol over Ethernet network (IP)	Easy and high-speed connection by ethernet line to a building management system. Allows access to multiple unit parameters	301-1101
Modbus over IP and RS485	149B	Bi-directional high-speed communication using Modbus protocol over Ethernet network (IP)	Easy and high-speed connection by ethernet line to a building management system. Allows access to multiple unit parameters	301-1101
High condensing temperature	150	Optimized compressor for operation at high condensing temperature	Increased condenser leaving water temperature up to 70°C. Allows applications with high condensing temperature (heat pumps, installations with not generously sized dry-coolers or more generally, installations with dry-coolers in hot climate). NOTE: to ensure control of the condenser leaving water temperature, this option must be fitted with 30XWH units.	301-1101
Condensing temperature limitation	150B	Limitation of the maximum condenser leaving water temperature to 45°C	Reduced maximum power input and current absorption: power cables and protection elements can therefore be downsized	301-1101
Control for low cond. temperature systems	152	Output signal (0-10 V) to control the condenser water inlet valve	Simple installation: for applications with cold water at condenser inlet (ex. ground-source, groundwater-source, superficial water-source applications) the signal permits to control a 2 or 3-way valve to maintain condenser water temperature (and so condensing pressure) at acceptable values	301-1101



## OPTIONS

Options	N°	Description	Advantages	Use
Dry-cooler control	154	Adaptation of the control box for communication with the dry-cooler via a bus. For dry cooler need to select the cabinet with option control cabinet manage by the chiller control	Easy system management, extended control capabilities of a remote dry-cooler	301-1101
Energy Management Module	156	EMM Control board with additional inputs/ outputs. See Energy Management Module option chapter	Extended remote control capabilities (Set-point reset, ice storage end, demand limits, boiler on/off command...)	301-1101
SmartVu™control, 7" user interface	158A	SmartVu™control supplied with a 7 inch colour touch screen user interface	Enhanced ease of use.	301-1101
Dual relief valves on 3-way valve	194	Three-way valve upstream of dual relief valves on the shell and tubes evaporator	Valve replacement and inspection facilitated without refrigerant loss. Comforms to European standard EN378/BGVD4	301-1101
Compliance with Swiss regulations	197	Additional tests on the water heat exchangers: supply (additional of PED documents) supplementary certificates and test certifications	Conformance with Swiss regulations	301-1101
Compliance with Australian regulations	200	Unit approved to Australian code	Conformance with Australian regulations	301-1101
Low noise level	257	Evaporator sound insulation	3 dB(A) quieter than standard unit	401-1101
Welded evaporator connection kit	266	Victaulic piping connections with welded joints	Easy installation	301-1101
Welded condenser water connection kit	267	Victaulic piping connections with welded joints	Easy installation	301-1101
Flanged evaporator water connection kit	268	Victaulic piping connections with flanged joints	Easy installation	301-1101
Flanged condenser water connection kit	269	Victaulic piping connections with flanged joints	Easy installation	301-1101
Thermal compressor insulation	271	The compressor is covered with a thermal insulation layer	Prevents air humidity to condensate on the compressor surface	301-1101
Free-cooling dry-cooler control	313	Control & connections to a Free Cooling Dry cooler 09PE or 09VE fitted with option FC control box	Easy system management, Extended control capabilities to a dry cooler used in Free Cooling mode	301-1101
Low GWP A1 R-515B refrigerant	330	Unit delivered with R-515B refrigerant charge (A1, GWP 299)	Reduced CO <sub>2</sub> footprint (GWP < 300) A1 safety class Reduced installed cost in technical room	301-1101

## PHYSICAL DATA, STANDARD UNITS

30XW-PZE / 30XWHPZE				301	401	451	551	601	651	801	901	1001	1101
<b>Heating</b>													
<b>Standard unit Full load performances*</b>	HW1	Nominal capacity	kW	322	448	509	657	698	758	916	1012	1168	1297
		COP	kW/kW	6,12	6,55	6,47	6,63	6,48	6,47	6,52	6,49	6,50	6,30
	HW2	Nominal capacity	kW	318	439	500	646	686	741	900	991	1146	1271
		COP	kW/kW	4,66	4,94	4,88	4,99	4,85	4,89	4,95	4,92	4,95	4,80
	HW3	Nominal capacity	kW	315	433	494	638	678	725	890	976	1129	1251
		COP	kW/kW	3,65	3,82	3,80	3,84	3,74	3,80	3,83	3,82	3,86	3,73
<b>Standard unit Seasonal energy efficiency**</b>	HW1	SCOP <sub>30/35°C</sub>	kW/kW	6,20	6,74	6,81	6,48	6,53	6,57	6,79	6,97	6,88	6,51
		η <sub>s heat</sub> <sub>30/35°C</sub>	%	240	262	264	251	253	255	264	271	267	252
	HW3	SCOP <sub>47/55°C</sub>	kW/kW	4,43	5,04	4,99	4,49	4,60	4,73	5,07	5,09	4,95	4,62
		η <sub>s heat</sub> <sub>47/55°C</sub>	%	169	194	192	171	176	181	195	195	190	177
		P <sub>rated</sub>	kW	411	540	615	795	845	908	1108	1218	1408	1562
	<b>Cooling</b>												
<b>Standard unit Full load performances*</b>	CW1	Nominal capacity	kW	271	385	435	561	595	648	783	874	1001	1111
		EER	kW/kW	5,28	5,75	5,66	5,80	5,66	5,69	5,74	5,83	5,80	5,65
	CW2	Nominal capacity	kW	375	538	610	764	813	880	1086	1220	1383	1522
		EER	kW/kW	8,00	8,15	7,99	8,55	8,17	8,33	8,10	8,13	8,27	8,13
<b>Standard unit Seasonal energy efficiency**</b>		SEER <sub>12/7°C</sub> <b>Comfort low temp.</b>	kWh/kWh	<b>6,43</b>	<b>7,03</b>	<b>7,35</b>	<b>6,54</b>	<b>6,65</b>	<b>6,97</b>	<b>7,10</b>	<b>7,59</b>	<b>7,61</b>	<b>7,14</b>
		η <sub>s cool</sub> <sub>12/7°C</sub>	%	<b>254</b>	<b>278</b>	<b>291</b>	<b>259</b>	<b>263</b>	<b>276</b>	<b>281</b>	<b>301</b>	<b>301</b>	<b>283</b>
		SEPR <sub>12/7°C</sub> <b>Process high temp.</b>	kWh/kWh	<b>9,27</b>	<b>8,76</b>	<b>8,75</b>	<b>9,36</b>	<b>8,78</b>	<b>8,84</b>	<b>8,76</b>	<b>9,06</b>	<b>9,26</b>	<b>9,19</b>

\* In accordance with standard EN14511-3:2022  
 \*\* In accordance with standard EN14825:2022, average climate  
 HW1 Heating mode conditions: Evaporator entering/leaving water temperature 10°C/7°C, condenser entering/leaving water temperature 30°C/35°C, evaporator and condenser fouling factor 0 m<sup>2</sup>.k/W  
 HW2 Heating mode conditions: Evaporator entering/leaving water temperature 10°C/7°C, condenser entering/leaving water temperature 40°C/45°C, evaporator and condenser fouling factor 0 m<sup>2</sup>.k/W  
 HW3 Heating mode conditions: Evaporator entering/leaving water temperature 10°C/7°C, condenser entering/leaving water temperature 47°C/55°C, evaporator and condenser fouling factor 0 m<sup>2</sup>.k/W  
 CW1 Cooling mode conditions: Evaporator water entering/leaving temperature 12°C/7°C, condenser entering/leaving water temperature 30°C/35°C, evaporator and condenser fouling factor 0 m<sup>2</sup>.K/W  
 CW2 Cooling mode conditions: Evaporator water entering/leaving temperature 23°C/18°C, condenser entering/leaving water temperature 30°C/35°C, evaporator and condenser fouling factor 0 m<sup>2</sup>.K/W  
 η<sub>s heat</sub><sub>30/35°C</sub> & SCOP<sub>30/35°C</sub> Values calculated in accordance with EN14825:2022  
 η<sub>s heat</sub><sub>47/55°C</sub> & SCOP<sub>47/55°C</sub> Values calculated in accordance with EN14825:2022  
 η<sub>s cool</sub><sub>12/7°C</sub> & SEER<sub>12/7°C</sub> **Bold values compliant to Ecodesign regulation: (EU) No 2016/2281 for Comfort application**  
 SEPR<sub>12/7°C</sub> **Bold values compliant to Ecodesign regulation: (EU) No 2016/2281 for Process application**



Eurovent certified values

## PHYSICAL DATA, STANDARD UNITS

30XW-PZE / 30XWHPZE		301	401	451	551	601	651	801	901	1001	1101
<b>Sound levels - standard unit</b>											
Sound power level <sup>(1)</sup>	dB(A)	93	97	97	97	97	97	100	100	100	100
Sound pressure level at 1 m <sup>(2)</sup>	dB(A)	76	80	80	79	79	79	81	81	81	81
<b>Sound levels - standard unit + option 257 <sup>(3)</sup></b>											
Sound power level <sup>(1)</sup>	dB(A)	-	94	94	94	94	94	97	97	97	97
Sound pressure level at 1 m <sup>(1)</sup>	dB(A)	-	76	76	76	76	76	78	78	78	78
<b>Dimensions - standard unit</b>											
Length	mm	2724	3059	3059	3290	3290	3290	4730	4730	4730	4730
Width	mm	928	936	936	1069	1069	1069	1039	1039	1162	1162
Height	mm	1567	1743	1743	1950	1950	1950	1997	1997	2051	2051
<b>Operating weight <sup>(4)</sup></b>											
	kg	2157	3050	3050	3942	3977	3995	6932	7010	7665	7875
<b>Compressors</b>											
Semi-hermetic 06T screw compressors, 50 r/s											
Circuit A	-	1	1	1	1	1	1	1	1	1	1
Circuit B	-	-	-	-	-	-	-	1	1	1	1
<b>Refrigerant - standard unit</b>											
R-1234ze											
Circuit A	kg	78	130	130	180	175	170	120	120	130	130
	teq CO <sub>2</sub>	0,5	0,9	0,9	1,3	1,2	1,2	0,8	0,8	0,9	0,9
Circuit B	kg	-	-	-	-	-	-	120	120	150	130
	teq CO <sub>2</sub>	-	-	-	-	-	-	0,8	0,8	1,1	0,9
<b>Refrigerant - option 330</b>											
R-515B											
Circuit A	kg	79	132	132	183	178	173	122	122	132	132
	teq CO <sub>2</sub>	23,1	38,7	38,7	53,6	52,2	50,7	35,7	35,7	38,7	38,7
Circuit B	kg	-	-	-	-	-	-	122	122	152	132
	teq CO <sub>2</sub>	-	-	-	-	-	-	35,7	35,7	44,5	38,7
<b>Oil - standard unit</b>											
HATCOL-4496											
Circuit A	l	20	20	20	25	25	25	20	20	25	25
Circuit B	l	-	-	-	-	-	-	20	20	20	25
<b>Capacity control</b>											
SmartVu™, electronic expansion valves (EXV)											
Minimum capacity	%	30	30	30	15	15	30	30	30	15	15
<b>Evaporator</b>											
Multi-pipe flooded type											
Water volume	l	61	101	101	154	154	154	293	293	321	321
Water connections (Victaulic)	in	5	6	6	8	8	8	8	8	8	8
Drain and vent connections (NPT)	in	3/8	3/8	3/8	3/8	3/8	3/8	3/8	3/8	3/8	3/8
Max. water-side operating pressure	kPa	1000	1000	1000	1000	1000	1000	1000	1000	1000	1000
<b>Condenser</b>											
Multi-pipe flooded type											
Water volume	l	55	103	103	148	148	148	316	316	340	340
Water connections (Victaulic)	in	5	6	6	8	8	8	8	8	8	8
Drain and vent connections (NPT)	in	3/8	3/8	3/8	3/8	3/8	3/8	3/8	3/8	3/8	3/8
Max. water-side operating pressure	kPa	1000	1000	1000	1000	1000	1000	1000	1000	1000	1000

(1) In dB ref=10<sup>-12</sup> W, (A) weighting. Declared dualnumber noise emission values in accordance with ISO 4871 (with an associated uncertainty of +/-3dB(A)). Measured in accordance with ISO 9614-1 and certified by Eurovent.

(2) In dB ref 20µPa, (A) weighting. Declared dualnumber noise emission values in accordance with ISO 4871 (with an associated uncertainty of +/-3dB(A)). For information, calculated from the sound power level Lw(A).

(3) Option 257 = Low noise level

(4) Weight shown is guideline only. Please refer to the unit nameplate

## ELECTRICAL DATA, STANDARD UNITS

30XW-PZE / 30XWHPZE		301	401	451	551	601	651	801	901	1001	1101
<b>Power circuit</b>											
Nom. power supply	V-ph-Hz	400-3-50									
Voltage range	V	360-440									
<b>Control circuit</b>											
24 V via the built-in transformer											
Nominal start-up current <sup>(1)</sup>											
Circuit A	A	303	414	414	587	587	587	414	414	587	587
Circuit B	A	-	-	-	-	-	-	414	414	414	587
Option 81	A	-	-	-	-	-	-	529	543	716	751
<b>Maximum start-up current<sup>(2)</sup></b>											
Circuit A	A	303	414	414	587	587	587	414	414	587	587
Circuit B	A	-	-	-	-	-	-	414	414	414	587
Option 81	A	-	-	-	-	-	-	597	621	794	855
<b>Cosine phi</b>											
Nominal <sup>(3)</sup>		0,79	0,86	0,87	0,85	0,87	0,89	0,86	0,87	0,85	0,85
Maximum <sup>(4)</sup>		0,90	0,90	0,90	0,90	0,90	0,90	0,90	0,90	0,90	0,90
Total harmonic distortion <sup>(4)</sup>	%	Closed to 0% (negligible)									
<b>Maximum power input<sup>(5)</sup></b>											
Circuit A	kW	86	112	126	148	165	174	112	126	148	148
Circuit B	kW	-	-	-	-	-	-	112	126	126	148
Option 81	kW	-	-	-	-	-	-	224	252	274	296
<b>Nominal current drawn<sup>(3)</sup></b>											
Circuit A	A	91	115	129	164	177	194	115	129	164	164
Circuit B	A	-	-	-	-	-	-	115	129	129	164
Option 81	A	-	-	-	-	-	-	230	258	293	328
<b>Maximum current drawn (Un)<sup>(5)</sup></b>											
Circuit A	A	140	180	205	240	268	282	180	205	240	240
Circuit B	A	-	-	-	-	-	-	180	205	205	240
Option 81	A	-	-	-	-	-	-	360	410	445	480
<b>Maximum current drawn (Un -10%)<sup>(4)</sup></b>											
Circuit A	A	153	196	223	261	292	307	196	223	261	261
Circuit B	A	-	-	-	-	-	-	196	223	223	261
Option 81	A	-	-	-	-	-	-	392	446	484	522
<b>Maximum power input with option 150B<sup>(5)</sup></b>											
Circuit A	kW	76	97	110	129	146	153	97	110	129	129
Circuit B	kW	-	-	-	-	-	-	97	110	110	129
Option 81	kW	-	-	-	-	-	-	195	220	239	258
<b>Maximum current drawn (Un) with option 150B<sup>(5)</sup></b>											
Circuit A	A	123	158	179	209	237	249	158	179	209	209
Circuit B	A	-	-	-	-	-	-	158	179	179	209
Option 81	A	-	-	-	-	-	-	316	358	388	418

- (1) Instantaneous start-up current (maximum operating current of the smallest compressor(s) + locked rotor current or reduced start-up current of the largest compressor). Values obtained at standard Eurovent conditions: evaporator entering/leaving water temp. = 12°C/7°C, condenser entering/leaving water temp. = 30°C/35°C.
- (2) Instantaneous start-up current (maximum operating current of the smallest compressor(s) + locked rotor current or reduced start-up current of the largest compressor). Values obtained at operation with maximum unit power input.
- (3) Values obtained at standard Eurovent conditions: evaporator entering/leaving water temp. = 12°C/7°C, condenser entering/leaving water temp. = 30°C/35°C.
- (4) Values obtained at operation with maximum unit power input.
- (5) Values obtained at operation with maximum unit power input. Values given on the unit nameplate.

## PHYSICAL DATA, UNITS FOR HIGH CONDENSING TEMPERATURES (OPTION 150)

30XW-ZE / 30XWHZE	301	401	451	551	601	651	801	901	1001	1101
-------------------	-----	-----	-----	-----	-----	-----	-----	-----	------	------

### Heating

Unit + option 150 Full load performances*	HW1	Nominal capacity	kW	319	462	516	642	697	771	912	1057	1159	1297
		COP	kW/kW	5,61	6,01	6,05	5,83	5,71	5,93	5,76	5,98	5,73	5,61
	HW2	Nominal capacity	kW	310	446	498	623	678	753	880	1018	1123	1260
		COP	kW/kW	4,59	4,93	4,97	4,8	4,7	4,91	4,74	4,93	4,74	4,66
	HW3	Nominal capacity	kW	302	433	482	605	661	734	853	983	1089	1223
		COP	kW/kW	3,78	4,05	4,09	3,95	3,88	4,06	3,89	4,06	3,94	3,88
	HW4	Nominal capacity	kW	293	420	467	585	645	715	828	950	1057	1186
		COP	kW/kW	3,07	3,29	3,32	3,21	3,16	3,29	3,15	3,29	3,21	3,18
Unit + option 150 Seasonal energy efficiency**	HW1	SCOP <sub>30/35°C</sub>	kWh/kWh	5,8	6,18	6,25	6,38	6,28	6,29	6,21	6,31	6,26	6,3
		ηs heat <sub>30/35°C</sub>	%	224	239	242	247	243	244	240	244	242	244
		SCOP <sub>47/55°C</sub>	kWh/kWh	4,7	4,77	4,83	4,86	4,84	4,9	4,77	4,87	4,84	4,89
	HW3	ηs heat <sub>47/55°C</sub>	%	180	183	185	186	186	188	183	187	186	187
		P <sub>rated</sub>	kW	421	544	607	761	829	922	1073	1240	1371	1539

### Cooling

Unit + option 150 Full load performances*	CW1	Nominal capacity	kW	269	393	439	547	591	656	776	910	985	1101
		EER	kW/kW	4,86	5,2	5,27	5,07	4,95	5,18	5,05	5,34	5,03	4,94
	CW2	Nominal capacity	kW	352	538	605	725	782	877	1057	1251	1332	1466
		EER	kW/kW	5,58	6,44	6,4	6,24	6,12	6,42	6,23	6,45	6,16	6,06
Unit + option 150 Seasonal energy efficiency**		SEER <sub>12/7°C</sub> Comfort low temp.	kWh/kWh	<b>6,24</b>	<b>6,57</b>	<b>6,65</b>	<b>6,52</b>	<b>6,57</b>	<b>6,5</b>	<b>6,67</b>	<b>6,8</b>	<b>6,63</b>	<b>6,6</b>
		ηs cool <sub>12/7°C</sub>	%	<b>247</b>	<b>260</b>	<b>263</b>	<b>258</b>	<b>260</b>	<b>257</b>	<b>264</b>	<b>269</b>	<b>262</b>	<b>261</b>
		SEPR <sub>12/7°C</sub> Process high temp.	kWh/kWh	6,80	7,01	7,07	7,39	6,97	6,99	6,96	7,23	7,11	7,30

\* In accordance with standard EN14511-3:2022  
 \*\* In accordance with standard EN14825:2022, average climate  
 HW1 Heating mode conditions: Evaporator entering/leaving water temperature 10°C/7°C, condenser entering/leaving water temperature 30°C/35°C, evaporator and condenser fouling factor 0 m<sup>2</sup>. kW  
 HW2 Heating mode conditions: Evaporator entering/leaving water temperature 10°C/7°C, condenser entering/leaving water temperature 40°C/45°C, evaporator and condenser fouling factor 0 m<sup>2</sup>. kW  
 HW3 Heating mode conditions: Evaporator entering/leaving water temperature 10°C/7°C, condenser entering/leaving water temperature 47°C/55°C, evaporator and condenser fouling factor 0 m<sup>2</sup>. kW  
 HW4 Heating mode conditions: Evaporator entering/leaving water temperature 10°C/7°C, condenser entering/leaving water temperature 55°C/65°C, evaporator and condenser fouling factor 0 m<sup>2</sup>. kW  
 CW1 Cooling mode conditions: Evaporator water entering/leaving temperature 12°C/7°C, outside air temperature 35°C, evaporator fouling factor 0 m<sup>2</sup>.K/W  
 CW2 Cooling mode conditions: Evaporator water entering/leaving temperature 23°C/18°C, outside air temperature 35°C, evaporator fouling factor 0 m<sup>2</sup>.K/W  
 ηs heat<sub>30/35°C</sub> & SCOP<sub>30/35°C</sub> Values calculated in accordance with EN14825:2022  
 ηs heat<sub>47/55°C</sub> & SCOP<sub>47/55°C</sub> Values calculated in accordance with EN14825:2022  
**ηs cool<sub>12/7°C</sub> & SEER<sub>12/7°C</sub> Bold values compliant to Ecodesign regulation: (EU) No 2016/2281 for Comfort application**  
 SEPR<sub>12/7°C</sub> Values calculated in accordance with EN14825:2022



Eurovent certified values

PRESENTATION COOLING HEATING AIR TREATMENT CONTROLS



## PHYSICAL DATA, UNITS FOR HIGH CONDENSING TEMPERATURES (OPTION 150)

30XWHPZE		301	401	451	551	601	651	801	901	1001	1101
Sound levels - unit with option 150											
Sound power level <sup>(1)</sup>	dB(A)	93	97	97	100	100	100	100	100	103	103
Sound pressure level at 1 m <sup>(2)</sup>	dB(A)	76	80	80	82	82	82	81	81	84	84
Sound levels - standard unit + option 257 <sup>(3)</sup>											
Sound power level <sup>(1)</sup>	dB(A)	-	94	94	98	98	98	97	97	101	101
Sound pressure level at 1 m <sup>(2)</sup>	dB(A)	-	76	76	80	80	80	78	78	82	82
Operating weight <sup>(4)</sup>	kg	2157	3050	3050	4102	4147	4175	6932	7010	7844	8182
Compressors											
Semi-hermetic 06T screw compressors, 50 r/s											
Circuit A	-	1	1	1	1	1	1	1	1	1	1
Circuit B	-	-	-	-	-	-	-	1	1	1	1
Refrigerant - unit with option 150											
R-1234ze											
Circuit A	kg	78	130	130	180	175	170	120	120	130	130
	teq CO <sub>2</sub>	0,5	0,9	0,9	1,3	1,2	1,2	0,8	0,8	0,9	0,9
Circuit B	kg	-	-	-	-	-	-	120	120	150	130
	teq CO <sub>2</sub>	-	-	-	-	-	-	0,8	0,8	1,1	0,9
Refrigerant - option 330											
R-515B											
Circuit A	kg	79	132	132	183	178	173	122	122	132	132
	teq CO <sub>2</sub>	23,1	38,7	38,7	53,6	52,2	50,7	35,7	35,7	38,7	38,7
Circuit B	kg	-	-	-	-	-	-	122	122	152	132
	teq CO <sub>2</sub>	-	-	-	-	-	-	35,7	35,7	44,5	38,7
Oil - unit with option 150											
HATCOL-4496											
Circuit A	l	20	20	20	25	25	25	20	20	25	25
Circuit B	l	-	-	-	-	-	-	20	20	20	25
Capacity control											
SmartVu™, electronic expansion valves (EXV)											
Minimum capacity	%	30	30	30	20	20	25	15	15	15	10
Evaporator											
Multi-pipe flooded type											
Water volume	l	61	101	101	154	154	154	293	293	321	321
Water connections (Victaulic)	in	5	6	6	8	8	8	8	8	8	8
Drain and vent connections (NPT)	in	3/8	3/8	3/8	3/8	3/8	3/8	3/8	3/8	3/8	3/8
Max. water-side operating pressure	kPa	1000	1000	1000	1000	1000	1000	1000	1000	1000	1000
Condenser											
Multi-pipe flooded type											
Water volume	l	55	103	103	148	148	148	316	316	340	340
Water connections (Victaulic)	in	5	6	6	8	8	8	8	8	10	10
Drain and vent connections (NPT)	in	3/8	3/8	3/8	3/8	3/8	3/8	3/8	3/8	3/8	3/8
Max. water-side operating pressure	kPa	1000	1000	1000	1000	1000	1000	1000	1000	1000	1000

(1) In dB ref=10<sup>-12</sup> W, (A) weighting. Declared dualnumber noise emission values in accordance with ISO 4871 (with an associated uncertainty of +/-3dB(A)). Measured in accordance with ISO 9614-1 and certified by Eurovent.

(2) In dB ref 20µPa, (A) weighting. Declared dualnumber noise emission values in accordance with ISO 4871 (with an associated uncertainty of +/-3dB(A)). For information, calculated from the sound power level Lw(A).

(3) Option 257 = Low noise level

(4) Weight shown is guideline only. Please refer to the unit nameplate

## ELECTRICAL DATA, UNITS FOR HIGH CONDENSING TEMPERATURES (OPTION 150)

30XW-PZE / 30XWHPZE		301	401	451	551	601	651	801	901	1001	1101
Power circuit											
Nominal power supply	V-ph-Hz	400-3-50									
Voltage range	V	360-440									
Control circuit		24 V via the built-in transformer									
Nominal start-up current <sup>(1)</sup>											
Circuit A	A	388	587	587	629	629	629	587	587	629	629
Circuit B	A	-	-	-	-	-	-	587	587	587	629
Option 81	A	-	-	-	-	-	-	712	725	767	815
Maximum start-up current <sup>(2)</sup>											
Circuit A	A	388	587	587	629	629	629	587	587	629	629
Circuit B	A	-	-	-	-	-	-	587	587	587	629
Option 81	A	-	-	-	-	-	-	833	860	902	972
Cosine phi nominal <sup>(3)</sup>		0,75	0,80	0,81	0,80	0,81	0,83	0,80	0,81	0,80	0,80
Cosine phi maximum <sup>(4)</sup>		0,90	0,90	0,90	0,89	0,89	0,89	0,90	0,90	0,89	0,89
Total harmonic distortion <sup>(4)</sup>		% Closed to 0% (negligible)									
Maximum power input <sup>(5)</sup>											
Circuit A	kW	107	144	158	202	219	228	144	158	202	202
Circuit B	kW	-	-	-	-	-	-	144	158	158	202
Option 81	kW	-	-	-	-	-	-	288	317	360	404
Nominal current drawn <sup>(3)</sup>											
Circuit A	A	102	125	138	186	197	213	125	138	186	186
Circuit B	A	-	-	-	-	-	-	125	138	138	186
Option 81	A	-	-	-	-	-	-	250	276	324	372
Maximum current drawn (Un) <sup>(5)</sup>											
Circuit A	A	174	234	257	328	356	371	234	257	328	328
Circuit B	A	-	-	-	-	-	-	234	257	257	328
Option 81	A	-	-	-	-	-	-	468	514	585	656
Max. current drawn (Un -10%) <sup>(4)</sup>											
Circuit A	A	190	255	280	357	387	404	255	280	357	357
Circuit B	A	-	-	-	-	-	-	255	280	280	357
Option 81	A	-	-	-	-	-	-	510	560	637	714

- (1) Instantaneous start-up current (maximum operating current of the smallest compressor(s) + locked rotor current or reduced start-up current of the largest compressor). Values obtained at standard Eurovent conditions: evaporator entering/leaving water temp. = 12°C/7°C, condenser entering/leaving water temp. = 30°C/35°C.
- (2) Instantaneous start-up current (maximum operating current of the smallest compressor(s) + locked rotor current or reduced start-up current of the largest compressor). Values obtained at operation with maximum unit power input.
- (3) Values obtained at standard Eurovent conditions: evaporator entering/leaving water temp. = 12°C/7°C, condenser entering/leaving water temp. = 30°C/35°C.
- (4) Values obtained at operation with maximum unit power input.
- (5) Values obtained at operation with maximum unit power input. Values given on the unit nameplate.

## DIMENSIONS/CLEARANCES

### 30XW-PZE/30XWHPZE 301-651

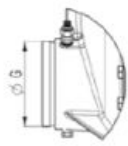
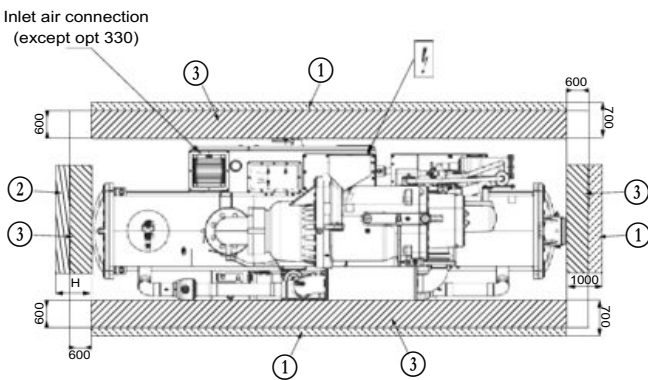
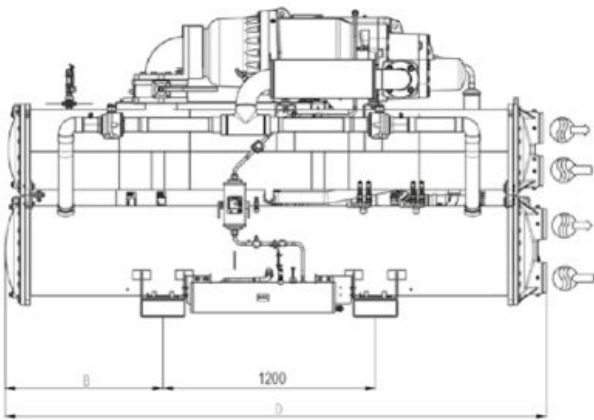
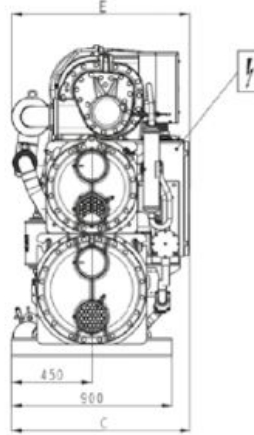
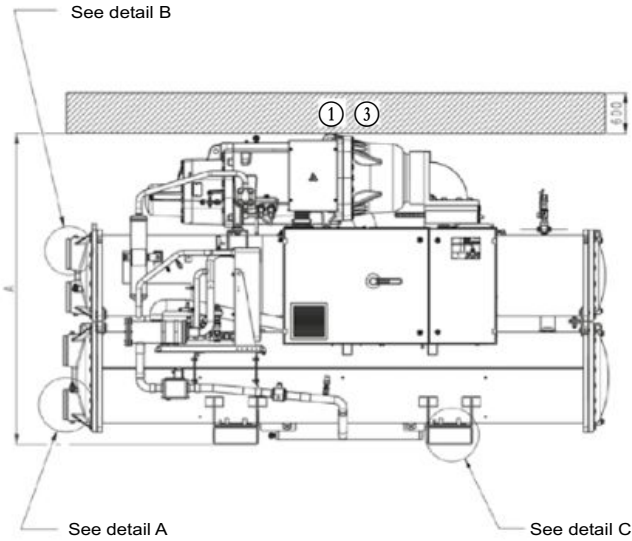

Detail A



Detail B



Detail C

Dimensions in mm								
	A	B	C	D	E	F	G	H
<b>30XW-PZE / 30XWHPZE</b>								
301	1612	800	982	2724	983	141,3	141,3	2600
401	1743	968	980	3059	982	168,3	168,3	2800
451	1743	968	980	3059	982	168,3	168,3	2800
551	1950	1083	1080	3290	1180	219,1	219,1	3100
601	1950	1083	1080	3290	1180	219,1	219,1	3100
651	1950	1083	1080	3290	1180	219,1	219,1	3100
<b>30XW-PZE / 30XWHPZE (option 150)</b>								
301	1612	800	982	2724	983	141,3	141,3	2600
401	1743	968	980	3059	982	168,3	168,3	2800
451	1743	968	1040	3059	1042	168,3	168,3	2800
551	1968	1083	1080	3290	1180	219,1	219,1	3100
601	1968	1083	1080	3290	1180	219,1	219,1	3100
651	1968	1083	1080	3290	1180	219,1	219,1	3100

#### Legend

All dimensions are given in mm

- ① Services clearances required
- ② Space required to remove cooler tubes
- ③ Zone ATEX
- Inlet water
- Outlet water
- Electrical supply entry

#### NOTES:

- Drawings are not contractually binding. Before designing an installation, consult the certified dimensional drawings supplied with the unit or available on request.
- For the positioning of the fixing points, weight distribution and centre of gravity coordinates please refer to the dimensional drawings.

**DIMENSIONS/CLEARANCES**

**30XW-PZE/30XWHPZE 801-1101**

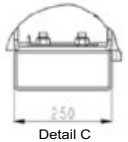
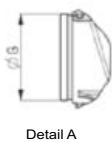
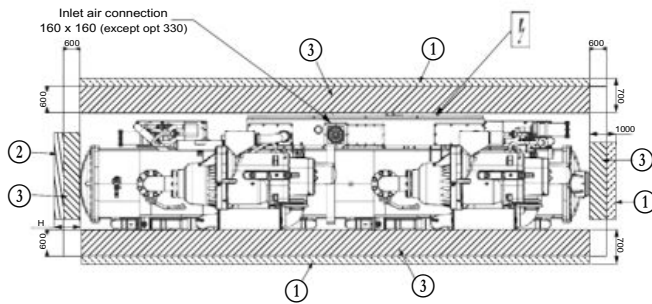
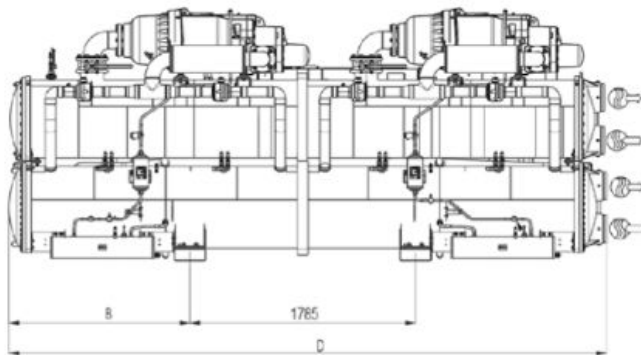
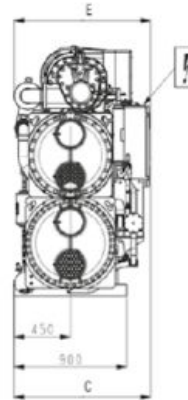
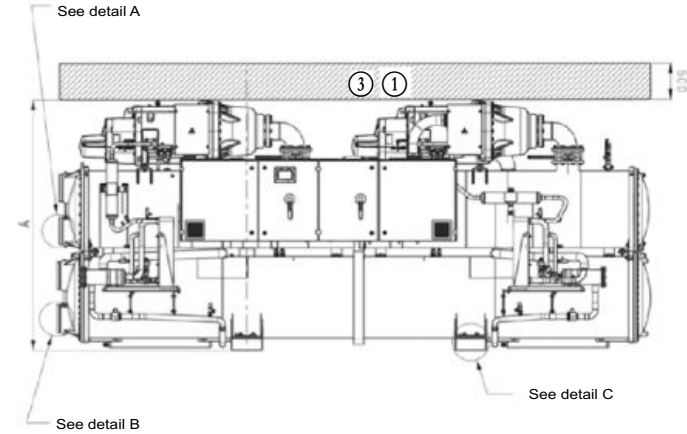

Dimensions in mm								
	A	B	C	D	E	F	G	H
<b>30XW-PZE / 30XWHPZE</b>								
<b>801</b>	1998	1512	1121	4730	1124	219,1	219,1	4500
<b>901</b>	1998	1512	1125	4730	1124	219,1	219,1	4500
<b>1001</b>	2051	1512	1238	4730	1238	219,1	219,1	4500
<b>1101</b>	2051	1512	1238	4730	1238	219,1	219,1	4500
<b>30XW-PZE / 30XWHPZE (option 150)</b>								
<b>801</b>	1998	1512	1121	4730	1124	219,1	219,1	4500
<b>901</b>	1998	1512	1125	4730	1124	219,1	219,1	4500
<b>1001</b>	2070	1512	1238	4730	1238	219,1	219,1	4500
<b>1101</b>	2051	1512	1238	4730	1238	219,1	219,1	4500

**Legend**

All dimensions are given in mm

- ① Services clearances required
- ② Space required to remove cooler tubes
- ③ Zone ATEX
- Inlet water
- Outlet water
- Electrical supply entry

**NOTES:**

- Drawings are not contractually binding. Before designing an installation, consult the certified dimensional drawings supplied with the unit or available on request.
- For the positioning of the fixing points, weight distribution and centre of gravity coordinates please refer to the dimensional drawings.

## WATER-COOLED VARIABLE-SPEED SCREW CHILLERS



- Low energy consumption
- High reliability
- Safe Design
- Easy and fast installation
- Minimised operating sound levels
- Environmental care
- Designed to support green building design

# 30XW-VZE-A



Nominal cooling capacity 448-1312 kW

The 30XW-VZE/30XWHVZE water-sourced units are the premium solution for commercial and industrial applications where installers, consultants and building owners require maximum quality and optimal performances, especially at part load.

The 30XW-VZE/30XWHVZE units are designed to meet current and future requirements in terms of energy efficiency, versatility and compactness. They feature exclusive inverter-driven screw compressors - an evolution of the proven traditional Carrier twin-rotor screw compressor design. Other features include:

- The new SmartVu™ control
- Mechanically cleanable flooded heat exchangers
- Refrigerant R-1234ze or R-515B

The 30XW-VZE/30XWHVZE range is splitted into two versions:

- 30XW-VZE for air conditioning applications
- 30XWHVZE for heating applications

As standard, the unit can provide an evaporator leaving water temperature down to 3.3°C, and when operating as a heat pump, it can deliver up to 55°C on the condenser side.



CARRIER participates in the ECP programme for LCP-HP  
Check ongoing validity of certificate:  
[www.eurovent-certification.com](http://www.eurovent-certification.com)

\* Evaporator with aluminium jacket shown in the picture not standard - available as special order only



## CUSTOMER BENEFITS

### Low energy consumption

- The 30XW-VZE/30XWHVZE are designed for high performance both at full load and at part load.
  - Eurovent certified values per EN14511-3:2022: SEPR up to 10.7 and SEER up to 8.8
- High energy efficiency
  - Inverter-driven twin-rotor screw compressors allow precise capacity matching of building load changes and significantly reduce unit power input, especially at part-load.
  - Flooded multi-pipe heat exchangers for increased heat exchange efficiency.
  - Electronic expansion device permits operation at a lower condensing pressure and improved utilisation of the evaporator heat exchange surface.
- Optimised electrical performance
  - All 30XW-VZE/30XWHVZE units comply with class 3 of standard EN61800-3. Category C3 refers to industrial environments. With option 282 category C2 compliance is possible.
  - Inverter-driven motors ensure negligible start-up current (value is lower than the maximum unit current draw)

### High reliability

- The 30XW-VZE and 30XWHVZE ranges offer increased global performance as well as Carrier's acclaimed product quality and reliability. Major components are selected and tested to minimize failures possibility, as well as many design choices have been taken in this perspective.
- Inverter-driven screw compressors
  - Industrial-type screw compressors with oversized bearings and motor cooled by suction gas.
  - The inverter is optimised for each compressor motor to ensure reliable operation and easy maintenance.
  - All compressor components are easily accessible on site minimising down-time.
- Refrigerant circuits
  - Two independent refrigerant circuits (from 1000 kW upwards); the second one automatically takes over, if the first one develops a fault, maintaining partial cooling under all circumstances.
  - All components have been selected and tested with R-1234ze refrigerant and R-515B
- Evaporator
  - Electronic paddle-free flow switch. Auto-setting according to cooler size and fluid type.
- Auto-adaptive control
  - Control algorithm prevents excessive compressor cycling
  - Automatic compressor unloading in case of abnormally high condensing pressure or discharge temperature.
- Exceptional endurance tests
  - Partnerships with specialised laboratories and use of limit simulation tools (finite element calculation) for the design of critical components.
  - Transport simulation test in the laboratory on a vibrating table and then on an endurance circuit (based on a military standard)

### Safe Design

- Specific polyol ester oil qualified by Carrier for using with HFO-1234ze and R-515B to guarantee and maintain reliable bearing lubrication.
- Specific compressor gaskets compatible with HFO-1234ze and R-515B, tested and validated by Carrier.
- New relief valves designed for operation with HFO-1234ze and R-515B
- New control algorithms
- Specific documentation that contains all the installation, operation, maintenance and safety Instructions.
- No need of electrical cabinet ducted fresh air supply

### Easy and fast installation

- Compact design
  - The 30XW-VZE/30XWHVZE units are designed to offer compact dimensions for easy installation.
  - With a width of approximately 1.25 m up to 1000 kW the units can pass through standard door openings and only require minimum floor space in the plant room.
- Simplified electrical connections
  - Transformer supply to the integrated control circuit (400/24 V)
- Simplified water connections
  - Victaulic connections on the evaporator and condenser
  - Practical reference marks for entering and leaving water connections
  - Possibility to reverse the heat exchanger water inlet and outlet at the factory
  - Possibility to modify the number of heat exchanger passes
- Fast commissioning
  - Systematic factory operation test before shipment
  - Quick-test function for step-by-step verification of the instruments, expansion devices and compressors.
  - Non flammable use possible when selecting option 330, Low GWP A1 R-515B Refrigerant

### Minimised operating sound levels

- The inverter technology used for the compressor motors minimises noise levels at part load operation. In two-compressor units at 25% of the maximum load the unit sound power level is reduced by 10 dB(A).
- Standard unit features include:
  - Silencers on the compressor discharge line.
  - Sound insulation on the components that are most subjected to radiated noise.
- Option 257 further reduces the global unit sound level.

## CUSTOMER BENEFITS

### Environmental care



- R-1234ze long-term refrigerant solution
  - HFO refrigerant with nearly zero global warming potential (GWP < 1) and zero ozone depletion potential (ODP = 0).
  - Not impacted by the HFC phase-down plan in Europe (79% HFC reduction in EU member states at 2030 horizon)
  - Compliant with refrigerant regulation in Switzerland that bans the use of HFC refrigerant in large capacity air-conditioning equipment.
- Leak-tight refrigerant circuit
  - Reduction of leaks as no capillary tubes and flare connections are used
  - Verification of pressure transducers and temperature sensors without transferring refrigerant charge
  - Discharge line shut-off valve and liquid line service valve for simplified maintenance.

### Designed to support green building design

- A green building is a building that is environmentally sustainable and has been designed, constructed and is operated to minimise the total impact on the environment. The underlying principles of this approach: The resulting building will be economical to operate, offer increased comfort and create a healthier environment for the people who live and work there, increasing productivity.
- The air conditioning system can use between 30 and 40% of the annual building energy consumption. Selection of the right air conditioning system is one of the main aspects to consider when designing a green building. For buildings with a variable load throughout the year 30XW-VZE/30XWHVZE units offers a solution to this important challenge.
- A number of green building certification programs exist in the market and offer third-party assessment of green building measures for a wide variety of building types.
- The following example looks at how Carrier's new 30XW-VZE/30XWHVZE range helps customers involved in LEED® building certification.

#### 30XW-VZE/30XWHVZE and LEED® certification

The LEED® (Leadership in Energy and Environmental Design) green building certification programme is a pre-eminent programme to rate the design, construction and operation of green buildings with points assigned in seven credit categories:

- Sustainable Sites (SS)
- Water Efficiency (WE)
- Energy & Atmosphere (EA)
- Materials & Resources (MR)
- Indoor Environmental Quality (IEQ)
- Innovation in Design (ID)
- Regional Priority (RP).

There are a number of different LEED® products.

While the strategies and categories assessed remain same, the point distribution varies to address different building types and application needs, for example according to New Construction, Schools, Core & Shell, Retail and Healthcare.

All programmes now use the same point scale:

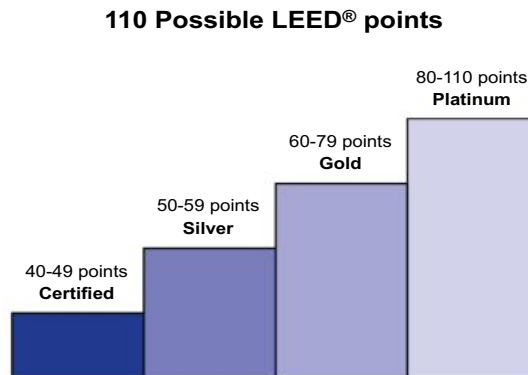

The majority of credits in LEED® rating systems are performance-based and achieving them is dependent on the impacts of each component or sub-system to the overall building.

While the LEED® green building certification programs do not certify products or services, the selection of the right products, systems or service programs is critical to obtain LEED® certification for a registered project, because the right products or service programmes can help meet the goals of green construction and ongoing operation and maintenance.

The choice of heating, ventilating and air conditioning (HVAC) products in particular can have a significant impact on LEED® certification, as the HVAC system directly impacts two categories that together influence 40% of the available points.

#### Overview of LEED® for new construction and major renovations

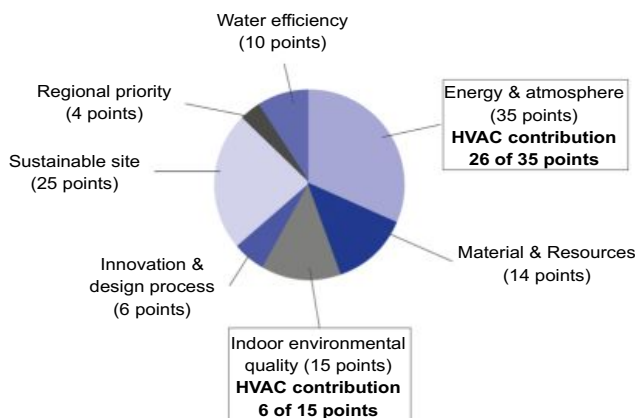

The new 30XW-VZE/30XWHVZE units from Carrier can assist building owners to earn LEED® points in particular in the Energy & Atmosphere (EA) credit category and help address the following prerequisites and credit requirements:

- **EA prerequisite 2: Minimum energy Performance**  
The 30XW-VZE/30XWHVZE exceeds the energy efficiency requirements of ASHRAE 90,1-2007; therefore it complies with the prerequisite standard.
- **EA prerequisite 3: Fundamental Refrigerant Management**  
The 30XW-VZE/30XWHVZE does not use chlorofluorocarbon (CFC) refrigerants thus satisfying the prerequisite statement.

## CUSTOMER BENEFITS

- **EA credit 1: Optimise energy performance (1 to 19 points)**  
Points for this credit are assigned depending on the energy cost reduction virtually achievable by the new building, compared to ASHRAE 90,1-2007 reference. The 30XW-VZE/30XWHVZE, which is designed for high performance especially during part load operation, contributes reducing the energy consumption of the building and therefore helps gaining points within this credit. In addition, the Carrier HAP (Hourly Analyses Program) can be used as an energy analyses program complying with the modeling requirements for this credit and produce reports that are easily transferable to LEED® templates.
- **EA credit 4: Enhanced refrigerant management (2 points)**  
With this credit, LEED® awards systems that minimise the Ozone Depletion Potential (ODP) and Global Warming Potential (GWP) of the system. The 30XW-VZE/30XWHVZE uses HFO-1234ze refrigerant with Global Warming Potential Index below 1 and therefore contributes toward satisfying this credit under LEED®.

**NOTE: This section describes the prerequisites and credit requirements in LEED® for New Construction and is directly related to the 30XW-VZE/30XWHV-ZE. Other prerequisites and credit requirements are not directly and purely related to the air-conditioning unit itself, but more to the control of the complete HVAC system.**

i-Vu®, Carrier's open control system, has features that can be valuable for:

- EA prerequisite 1: Fundamental commissioning of energy management system
- EA credit 3: Enhanced commissioning (2 points)
- EA credit 5: Measurements and verification (3 points).

**NOTE: Products are not reviewed or certified under LEED®. LEED® credit requirements cover the performance of materials in aggregate, not the performance of individual products or brands. For more information on LEED®, visit [www.usgbc.org](http://www.usgbc.org).**

## TECHNICAL INSIGHTS

### SmartVu™

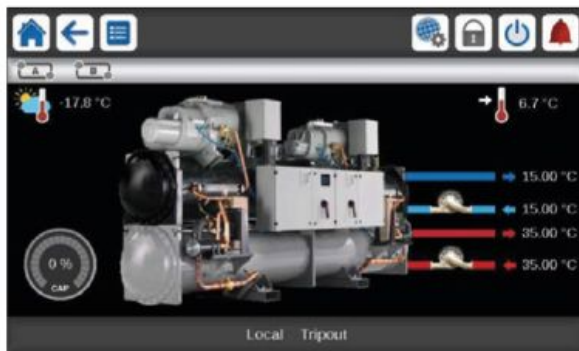

- New innovative smart control features :
  - An intuitive and user-friendly, coloured, 7" interface
  - 1 languages available on choice :DE, EN, ES,FR,T,NL PT, TR, TU + one additional customer choice
  - Screen-shots with concise and clear information in local languages
  - Complete menu, customised for different users (end user, service personnel and Carrier-factory technicians)
  - Setpoint offset based on the outside air temperature
  - Safe operation and unit setting: Password protection ensures that unauthorised people cannot modify any advanced parameters
  - Simple and "smart" intelligence uses data collection from the constant monitoring of all machine parameters to optimise unit operation
  - Night-mode: Cooling capacity management for reduced Noise level.
  - With hydraulic module: Water pressure display and water flow rate calculation.
- Energy management :
  - Internal time schedule clock controls chiller on/off times and operation at a second set-point
  - The DCT (Data Collection Tool) records the alarms history to simplify and facilitate service operations.
- Maintenance functions :
  - F-Gas regulation leak check reminder alert
  - Maintenance alert can be configured to days, months or hours of operation

- Advanced communication features :
  - Easy and high-speed communication technology over Ethernet (IP) to a centralised building management system
  - Access to multiple unit parameters.

### Remote Management (Standard)

- Units with SmartVu™ control can be easily accessed from the internet, using a PC with an Ethernet connection. This makes remote control quick and easy and offers significant advantages for service operations
- Aquaforce with Greenspeed® Intelligence is equipped with an RS485 serial port that offers multiple remote control, monitoring and diagnostic possibilities. When networked with other Carrier equipment through the CCN (Carrier Comfort Network - proprietary protocol), all components form a HVAC system fully-integrated and balanced through one of the Carrier's network system products, like the Chiller System anager or the Plant System anager (optional).
- The chiller also communicates with other building management systems via optional communication gateways (BACnet, LON or JBus).
- The following commands/visualisations are possible from remote connection:
  - Start/Stop of the machine
  - Dual set-point management: Through a dedicated contact is possible to activate a second set-point (example, unoccupied mode)
  - Demand limit setting: To limit the maximum chiller capacity to a predefined value
  - Water pump control: These outputs control the contactors of one/two evaporator water pumps.
  - Water pumps changeover (only with hydraulic module options): These contacts are used to detect a water pump operation fault and automatically change over to the other pump.
  - Operation visualisation: indication if the unit is operating or if it is in stand-by (no cooling load)
  - Alarm visualisation.

## TECHNICAL INSIGHTS

### Remote management (EMM option)

- The Energy management module (EMM) offers extended remote control possibilities:
- Room temperature: Permits set-point reset based on the building indoor air temperature (if Carrier thermostats are installed)
- Set-point reset: Allows reset of the cooling set-point based on a 4-20 mA or 0-10 V signal
- Demand limit: Permits limitation of the maximum chiller capacity based on 0-10 V signal
- Demand limit 1 and 2: Closing of these contacts limits the maximum chiller capacity to two predefined values.
- User safety: This contact can be used for any customer safety loop; opening the contact generates a specific alarm.
- Ice storage end: When ice storage has finished, this input permits return to the second set-point (unoccupied mode).
- Time schedule override: Closing of this contact cancels the programmed time schedule.
- Out of service: This signal indicates that the chiller is completely out of service.
- Chiller capacity: This analogue output (0-10 V) gives an immediate indication of the chiller capacity.
- Alert indication: This volt-free contact indicates the necessity to carry out a maintenance operation or the presence of a minor fault.
- Compressors running status: Set of outputs (as many as the compressors number) indicating which compressors are running.

### Remote management (EMM option)

The Energy Management Module offers extended remote control possibilities:

- Room temperature: permits set-point reset based on the building indoor air temperature (with Carrier thermostat)
- Set point reset: ensures reset of the cooling set-point based on a 0-10 V signal
- Demand limit: permits limitation of the maximum chiller power or current based on a 0-10 V signal
- Demand limit 1 and 2: closing of these contacts limits the maximum chiller power or current to two predefined values
- User safety: this contact can be used for any customer safety loop; opening the contact generates a specific alarm
- Ice storage end: when ice storage has finished, this input permits return to the second set-point (unoccupied mode)
- Time schedule override: closing of this contact cancels the time schedule effects
- Out of service: this signal indicates that the chiller is completely out of service

### Digit number

1	2	3	4	5	6	7	8	9	10	11	12	13	14	15	16	17	18
3	0	X	W	-	V	Z	E	0	3	0	1	B	0	0	0	1	-

**Legend :**

- Digit 1 to 4: Water-cooled chiller with screw compressor
- Digit 5: Application type, - = Cooling, H = Heating
- Digit 6: Efficiency, V = Variable
- Digit 7 & 8: Unit using R1234ze refrigerant
- Digit 9 to 12: Model number based on cooling capacity in kW
- Digit 13: index For major product modification (visible impact for customer)
- Digit 14 to 17: Counter used to generate a one time product code
- Digit 18: Not used

- Chiller capacity: this analogue output (0-10 V) gives an immediate indication of the chiller capacity
- Alert indication: this volt-free contact indicates the necessity to carry out a maintenance operation or the presence of a minor fault.
- Compressors running status : set of outputs (as many as the compressors number) indicating which compressors are running.

### New inverter-driven Thunderbolt screw compressor

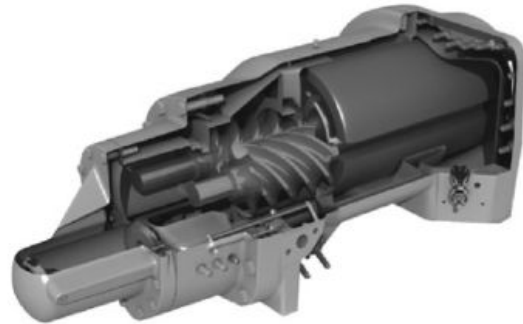

- The Carrier 06T screw compressor designed for operation with HFO-1234ze refrigerant benefits from Carrier's long experience in the development of twin-rotor screw compressors. The design of the Thunderbolt compressors is based on the successful 06T screw compressor, core of the well-known Aquaforce series.
- Advanced control algorithms combine inverter frequency output with motor input logic to minimise mechanical part stress, resulting in best compression performance and high chiller reliability. The compressor is equipped with bearings with oversized rollers, oil pressure lubricated for reliable and durable operation, even at maximum load.
- Screw compressors use positive displacement principle to compress gases at higher pressure. As a result, in case of exceptional high temperature condenser side (due for example to water-pipes fouling or operation in harsh climate with an external dry cooler) the compressor does not switch off, but continues operation at reduced capacity (unloaded mode).
- The silencer in the discharge line considerably reduces discharge gas pulsations for much quieter operation.
- The condenser includes an oil separator that minimises the amount of oil in circulation in the refrigerant circuit and re-directs it to the compressor function.



## OPTIONS

Options	N°	Description	Advantages	Use
Light-brine solution, down to -3°C	8	Implementation of new algorithms of control to allow chilled brine solution production down to -3°C when ethylene glycol is used (0°C with propylene glycol)	Matches with most application requirements for ground-sourced heat pumps and fits with many industrial processes requirements	451-1301 (see dedicated paragraph)
Master/slave operation	58	Unit equipped with supplementary water outlet temperature sensor kit to be field-installed allowing master/slave operation of two units connected in parallel	Optimised operation of two units connected in parrallele operation with operating time equalisation	451-1301
Condenser insulation	86	Thermal condenser insulation	Minimizes thermal dispersions condenser side (key option for heat pump or heat recovery applications) and allows compliancy with special installation criteria (hot parts insulated)	451-1301
Service valve set	92	Liquid line valve (evaporator inlet) and compressor suction line valve	Allow isolation of various refrigerant circuit components for simplified service and maintenance	451-1301
Evaporator with one pass less	100C	Evaporator with one pass on the water side. Evaporator inlet and outlet on opposite sides.	Easy to install, depending on site. Reduced pressure drops	451-1301
Condenser with one pass less	102C	Condenser with one pass on the water side. Condenser inlet and outlet on opposite sides.	Easy to install, depending on site. Reduced pressure drops	451-1301
21 bar evaporator	104	Reinforced evaporator for extension of the maximum water-side service pressure to 21 bar (standard 10 bar)	Covers applications with a high water column evaporator side (typically high buildings)	451-1301
21 bar condenser	104A	Reinforced condenser for extension of the maximum water-side service pressure to 21 bar (standard 10 bar)	Covers applications with a high water column condenser side (typically high buildings)	451-1301
Reversed evaporator water connections	107	Evaporator with reversed water inlet/outlet	Easy installation on sites with specific requirements	451-1301
Reversed condenser water connections	107A	Condenser with reversed water inlet/outlet	Easy installation on sites with specific requirements	451-1301
Lon gateway	148D	Two-directional communication board complying with Lon Talk protocol	Connects the unit by communication bus to a building management system	451-1301
Bacnet over IP	149	Two-directional high-speed communication using BACnet protocol over Ethernet network (IP)	Easy and high-speed connection by ethernet line to a building management system. Allows access to multiple unit parameters	451-1301
Modbus over IP and RS485	149B	Bi-directional high-speed communication using Modbus protocol over Ethernet network (IP)	Easy and high-speed connection by ethernet line to a building management system. Allows access to multiple unit parameters	451-1301
Condensing temperature limitation	150B	Limitation of the maximum condenser leaving water temperature to 45°C	Reduced maximum power input and current absorption: power cables and protection elements can therefore be downsized	451-1301
Control for low cond. temperature systems	152	Output signal (0-10 V) to control the condenser water inlet valve	Simple installation: for applications with cold water at condenser inlet (ex. ground-source, groundwater-source, superficial water-source applications) the signal permits to control a 2 or 3-way valve to maintain condenser water temperature (and so condensing pressure) at acceptable values	451-1301
Energy Management Module	156	EMM Control board with additional inputs/ outputs. See Energy Management Module option chapter	Extended remote control capabilities (Set-point reset, ice storage end, demand limits, boiler on/off command...)	451-1301
Input contact for Refrigerant leak detection	159	0-10 V signal to report any refrigerant leakage in the unit directly on the controller (the leak detector itself must be supplied by the customer)	Immediate customer notification of refrigerant losses to the atmosphere, allowing timely corrective actions	451-1301
Dual relief valves on 3-way valve	194	Three-way valve upstream of dual relief valves on the shell and tubes evaporator	Valve replacement and inspection facilitated without refrigerant loss. Comforms to European standard EN378/BGVD4	451-1301
Compliance with Swiss regulations	197	Additional tests on the water heat exchangers: supply (additional of PED documents) supplementary certificates and test certifications	Conformance with Swiss regulations	451-1301



## OPTIONS

Options	N°	Description	Advantages	Use
Compliance with Russian regulations	199	EAC certification	Conformance with Russian regulations	451-1301
Compliance with Australian regulations	200	Unit approved to Australian code	Conformance with Australian regulations	451-1301
Low noise level	257	Evaporator sound insulation	3 dB(A) quieter than standard unit	451-1301
Welded evaporator connection kit	266	Victaulic piping connections with welded joints	Easy installation	451-1301
Welded condenser water connection kit	267	Victaulic piping connections with welded joints	Easy installation	451-1301
Flanged evaporator water connection kit	268	Victaulic piping connections with flanged joints	Easy installation	451-1301
Flanged condenser water connection kit	269	Victaulic piping connections with flanged joints	Easy installation	451-1301
Thermal compressor insulation	271	The compressor is covered with a thermal insulation layer	Prevents air humidity to condensate on the compressor surface	451-1301
EMC classification C2, as per EN 61800-3	282	Additional RFI filters on the unit power line	Reduces electromagnetic interferences for compliance with emission level category C2 in order to allow the units to operate in the first environment (so called, residential environment)	451-1301
Fast Capacity Recovery	295	New software algorithms to allow quick restart and fast loading while preserving unit-reliability	Full capacity recovery in approximately 6 minutes after power failure. Matches requirements of typical critical missions application	451-1301
Compliance with Morocco regulation	327	Specifics documents according Morocco regulation	Conformance with Morocco regulations	451-1301
Low GWP A1 R-515B refrigerant	330	Unit delivered with R-515B refrigerant charge (A1, GWP 299)		451-1301

PHYSICAL DATA, 30XW-VZE UNITS

30XW-V ZE / 30XWHVZE				451	501	601	651	851	1001	1101	1201	1301
<b>Heating</b>												
<b>Standard unit</b> Full load performances*	HW1	Nominal capacity	kW	523	581	730	780	1017	1157	1304	1450	1555
		COP	kW/kW	6,3	6,14	6,04	5,92	6,27	6,29	6,12	5,74	5,61
	HW2	Nominal capacity	kW	491	544	677	730	955	1081	1211	1344	1452
		COP	kW/kW	4,74	4,6	4,55	4,39	4,73	4,73	4,67	4,42	4,28
	HW3	Nominal capacity	kW	466	508	628	689	906	1007	1122	1242	1367
		COP	kW/kW	3,52	3,41	3,42	3,24	3,51	3,5	3,52	3,39	3,22
<b>Standard unit</b> Seasonal energy efficiency **	HW1	SCOP <sub>30/35°C</sub>	kWh/kWh	7,64	7,39	7,62	7,57	7,45	7,4	7,17	6,64	6,56
		ηs heat <sub>30/35°C</sub>	%	298	288	297	295	290	288	279	257	254
		SCOP <sub>47/55°C</sub>	kWh/kWh	5,34	5,3	5,26	5,21	5,31	5,39	5,46	5,17	5,11
	HW3	ηs heat <sub>47/55°C</sub>	%	206	204	202	201	204	207	210	199	197
		P <sub>rated</sub>	kW	559	614	761	827	1086	1217	1361	1507	1645
<b>Cooling</b>												
<b>Standard unit</b> Full load performances*	CW1	Nominal capacity	kW	448	496	620	660	870	991	1115	1227	1312
		EER	kW/kW	5,53	5,39	5,26	5,14	5,57	5,6	5,47	5,14	5,05
	CW2	Nominal capacity	kW	670	728	915	970	1301	1455	1296	1423	1521
		EER	kW/kW	7,88	7,49	7,26	7,14	7,9	7,74	6,19	5,76	5,7
<b>Standard unit</b> Seasonal energy efficiency **	<b>SEER<sub>12/7°C</sub> Comfort low temp.</b>		<b>kWh/kWh</b>	<b>8,12</b>	<b>8,15</b>	<b>8,77</b>	<b>8,37</b>	<b>8,41</b>	<b>8,48</b>	<b>7,48</b>	<b>7,33</b>	<b>7,13</b>
	<b>ηs cool<sub>12/7°C</sub></b>		<b>%</b>	<b>322</b>	<b>323</b>	<b>348</b>	<b>332</b>	<b>333</b>	<b>336</b>	<b>296</b>	<b>290</b>	<b>282</b>
	<b>SEPR<sub>12/7°C</sub> Process high temp.</b>		<b>kWh/kWh</b>	<b>10,49</b>	<b>10,23</b>	<b>10,42</b>	<b>10,03</b>	<b>10,71</b>	<b>10,71</b>	<b>9,66</b>	<b>9,12</b>	<b>9,10</b>
<b>Sound levels - standard unit</b>												
		Sound power level <sup>(1)</sup>	dB(A)	103	103	103	103	104	104	104	104	104
		Sound pressure level at 1 m <sup>(2)</sup>	dB(A)	85	85	85	85	85	85	85	85	85
<b>Sound levels - standard unit + option 257<sup>(3)</sup></b>												
		Sound power level <sup>(1)</sup>	dB(A)	100	100	100	100	101	101	101	101	101
		Sound pressure level at 1 m <sup>(2)</sup>	dB(A)	82	82	82	82	82	82	82	82	82
<b>Dimensions - standard unit</b>												
		Length	mm	3059	3059	3290	3290	4730	4730	4730	4730	4730
		Width	mm	1087	1087	1237	1237	1164	1164	1264	1264	1264
		Height	mm	1743	1743	1948	1948	1997	1997	2051	2051	2051

\* In accordance with standard EN14511-3:2022  
 \*\* In accordance with standard EN14825:2022, average climate  
 HW1 Heating mode conditions: Evaporator entering/leaving water temperature 10°C/7°C, condenser entering/leaving water temperature 30°C/35°C, evaporator and condenser fouling factor 0 m². k/W  
 HW2 Heating mode conditions: Evaporator entering/leaving water temperature 10°C/7°C, condenser entering/leaving water temperature 40°C/45°C, evaporator and condenser fouling factor 0 m². k/W  
 HW3 Heating mode conditions: Evaporator entering/leaving water temperature 10°C/7°C, condenser entering/leaving water temperature 47°C/55°C, evaporator and condenser fouling factor 0 m². k/W  
 CW1 Cooling mode conditions: Evaporator water entering/leaving temperature 12°C/7°C, condenser entering/leaving water temperature 30°C/35°C, evaporator and condenser fouling factor 0 m².K/W  
 CW2 Cooling mode conditions: Evaporator water entering/leaving temperature 23°C/18°C, condenser entering/leaving water temperature 30°C/35°C, evaporator and condenser fouling factor 0 m².K/W  
 ηs heat<sub>30/35°C</sub> & SCOP<sub>30/35°C</sub> Values calculated in accordance with EN14825:2022  
 ηs heat<sub>47/55°C</sub> & SCOP<sub>47/55°C</sub> Values calculated in accordance with EN14825:2022  
 ηs cool<sub>12/7°C</sub> & SEER<sub>12/7°C</sub> **Bold values compliant to Ecodesign regulation: (EU) No 2016/2281 for Comfort application**  
 SEPR<sub>12/7°C</sub> **Bold values compliant to Ecodesign regulation: (EU) No 2016/2281 for Process application**  
 (1) In dB ref=10<sup>-12</sup> W, (A) weighting. Declared dualnumber noise emission values in accordance with ISO 4871 (with an associated uncertainty of +/-3dB(A)). Measured in accordance with ISO 9614-1 and certified by Eurovent.3dB(A)). Measured in accordance with ISO 9614-1 and certified by Eurovent.  
 (2) in dB ref 20µPa, (A) weighting. Declared dualnumber noise emission values in accordance with ISO 4871 (with an associated uncertainty of +/-3dB(A)). For information, calculated from the sound power level Lw(A).  
 (3) Option 257 = Low noise level  
 (4) Weight shown is guideline only. To find out the unit refrigerant charge, please refer to the unit nameplate



Eurovent certified values

## PHYSICAL DATA, 30XW-VZE UNITS

30XW-V ZE / 30XWHVZE		451	501	601	651	851	1001	1101	1201	1301
<b>Operating weight<sup>(4)</sup></b>	kg	3223	3261	4263	4267	7477	7553	7731	7932	7970
<b>Compressors</b>		Semi-hermetic 06T screw compressors, 60 r/s								
Circuit A	-	1	1	1	1	1	1	1	1	1
Circuit B	-	-	-	-	-	1	1	1	1	1
<b>Oil - standard unit</b>		HATCOL-4496								
Circuit A	l	20	20	25	25	20	20	25	25	25
Circuit B	l	-	-	-	-	20	20	20	25	25
<b>Refrigerant - standard unit</b>		R1234ze (E)								
Circuit A	kg	130	130	180	175	120	120	115	115	110
	teq CO <sub>2</sub>	0,9	0,9	1,3	1,2	0,8	0,8	0,8	0,8	0,8
Circuit B	kg	-	-	-	-	120	120	120	115	110
	teq CO <sub>2</sub>	-	-	-	-	0,8	0,8	0,8	0,8	0,8
<b>Refrigerant - option 330</b>		R515B								
Circuit A	kg	132	132	183	178	122	122	117	117	112
	teq CO <sub>2</sub>	38,7	38,7	53,6	52,2	35,7	35,7	34,3	34,3	32,8
Circuit B	kg	-	-	-	-	122	122	122	117	112
	teq CO <sub>2</sub>	-	-	-	-	35,7	35,7	35,7	34,3	32,8
<b>Capacity control</b>		SmartVu™, inverter-driven compressor, electronic expansion valve (EXV)								
Minimum capacity	%	30	30	15	15	30	30	15	15	15
<b>Evaporator</b>		Multi-pipe flooded type								
Water volume	l	106	106	154	154	297	297	297	297	297
Water connections (Victaulic)	in	6	6	8	8	8	8	8	8	8
Drain and vent connections (NPT)	in	3/8	3/8	3/8	3/8	3/8	3/8	3/8	3/8	3/8
Max. water-side operating pressure	kPa	1000	1000	1000	1000	1000	1000	1000	1000	1000
<b>Condenser</b>		Multi-pipe flooded type								
Water volume	l	112	112	165	165	340	340	340	340	340
Water connections (Victaulic)	in	6	6	8	8	8	8	8	8	8
Drain and vent connections (NPT)	in	3/8	3/8	3/8	3/8	3/8	3/8	3/8	3/8	3/8
Max. water-side operating pressure	kPa	1000	1000	1000	1000	1000	1000	1000	1000	1000

(4) Weight shown is guideline only. To find out the unit refrigerant charge, please refer to the unit nameplate

## ELECTRICAL DATA

30XW-VZE /30XWHVZE		451	501	601	651	851	1001	1101	1201	1301
<b>Power circuit</b>										
Nominal power supply	V-ph-Hz	400-3-50								
Voltage range	V	360-440								
<b>Control circuit</b>										
24 V via the built-in transformer										
<b>Start-up current<sup>(1)</sup></b>	A	Negligible (lower than maximum current drawn)								
<b>Maximum power factor<sup>(2)</sup></b>		0,91-0,93	0,91-0,93	0,91-0,93	0,91-0,93	0,91-0,93	0,91-0,93	0,91-0,93	0,91-0,93	0,91-0,93
<b>Cosine phi</b>		> 0,98	> 0,98	> 0,98	> 0,98	> 0,98	> 0,98	> 0,98	> 0,98	> 0,98
<b>Harmonic distortion rate<sup>(3)</sup></b>	%	35-45	35-45	35-45	35-45	35-45	35-45	35-45	35-45	35-45
<b>Maximum power input<sup>(4)</sup></b>										
Circuit A	kW	135	157	189	208	135	157	189	189	208
Circuit B	kW	-	-	-	-	135	157	157	189	208
With option 81	kW	-	-	-	-	270	314	346	378	416
<b>Eurovent current draw*</b>										
Circuit A	A	129	148	180	197	129	149	180	180	197
Circuit B	A	-	-	-	-	129	149	149	180	197
With option 81	A	-	-	-	-	258	298	329	360	394
<b>Maximum current draw (Un)<sup>(4)</sup></b>										
Circuit A	A	195	245	295	325	195	245	295	295	325
Circuit B	A	-	-	-	-	195	245	245	295	325
With option 81	A	-	-	-	-	390	490	540	590	650
<b>Maximum current draw (Un -10%)<sup>(3)</sup></b>										
Circuit A	A	206	260	313	345	206	260	313	313	345
Circuit B	A	-	-	-	-	206	260	260	313	345
With option 81	A	-	-	-	-	412	520	573	626	690
<b>Maximum power input with option 150B<sup>(4)</sup></b>										
Circuit A	kW	106	134	161	177	106	134	161	161	177
Circuit B	kW	-	-	-	-	106	134	134	161	177
With option 81	kW	-	-	-	-	212	268	295	322	354
<b>Maximum current draw (Un) with option 150B<sup>(4)</sup></b>										
Circuit A	A	169	213	257	283	169	213	257	257	283
Circuit B	A	-	-	-	-	169	213	213	257	283
With option 81	A	-	-	-	-	338	426	470	514	566
<b>Dissipated power<sup>(3)</sup></b>	W	3000	4200	4700	5300	6000	8400	8900	9400	10600

(1) Instantaneous start-up current.

(2) May vary, based on the short-circuit current/max. current draw ratio of the system transformer. Values obtained at operation with maximum unit power input.

(3) Values obtained at operation with maximum unit power input.

(4) Values obtained at operation with maximum unit power input. Values given on the unit name plate.

\* Eurovent unit operating conditions: evaporator entering/leaving water temperature = 12°C/7°C, condenser entering/leaving water temperature = 30°C/35°C. Gross performances, not in accordance with EN14511-3:2022. These performances do not take into account the correction for the proportional heating capacity and power input generated by the water pump to overcome the internal pressure drop in the heat exchanger.

## DIMENSIONS/CLEARANCES

### 30XW-VZE/30XWHVZE 451-651

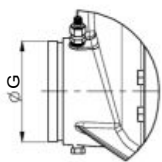
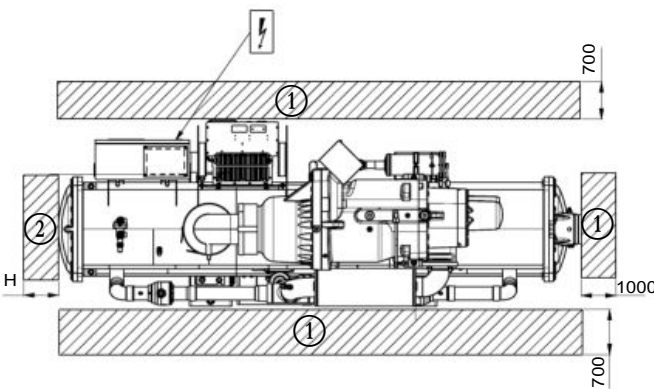
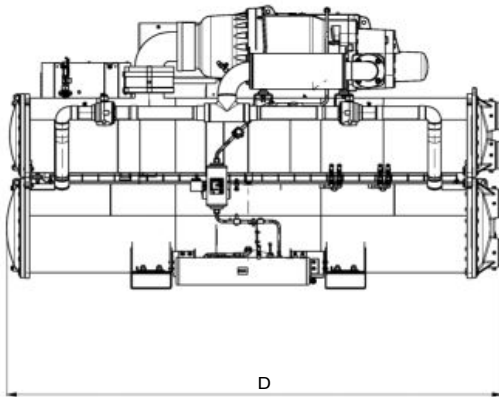
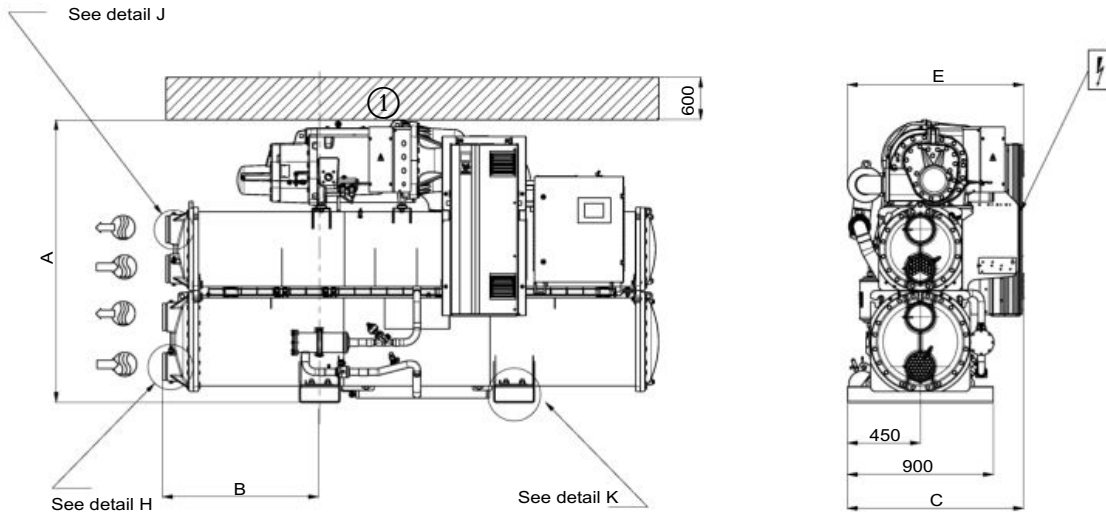

Detail H

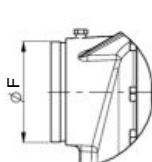

Detail J

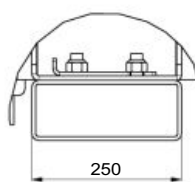

Detail K

	Dimensions in mm							
	A	B	C	D	E	F	G	H
<b>30XW-VZE/30XWHVZE</b>								
<b>451</b>	1743	968	1087	3059	1086	168,3	168,3	2800
<b>501</b>	1743	968	1087	3059	1086	168,3	168,3	2800
<b>601</b>	1948	1083	1137	3290	1237	219,1	219,1	3100
<b>651</b>	1948	1083	1137	3290	1237	219,1	219,1	3100

#### Legend

All dimensions are given in mm

- ① → Services clearances required
- ② → Space required to remove
- Inlet water
- Outlet water
- Electrical supply entry

#### NOTES:

Drawings are not contractually binding. Before designing an installation, consult the certified dimensional drawings supplied with the unit or available on request.

For the positioning of the fixing points, weight distribution and centre of gravity coordinates please refer to the dimensional drawings.



## DIMENSIONS/CLEARANCES

### 30XW-VZE/30XWHVZE 851-1301

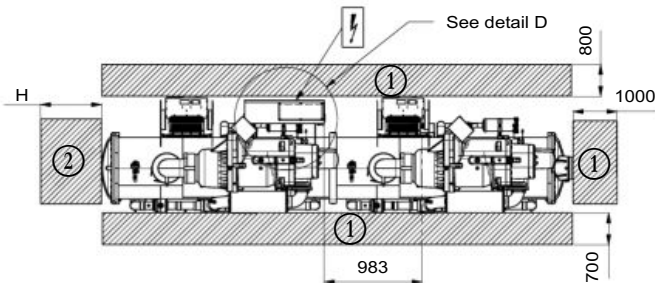
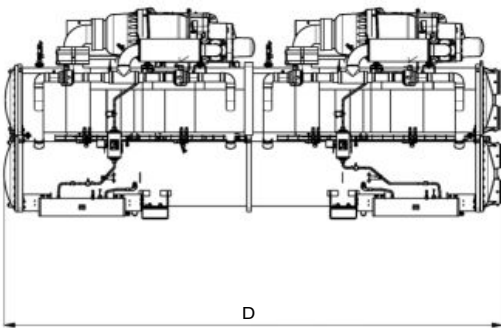
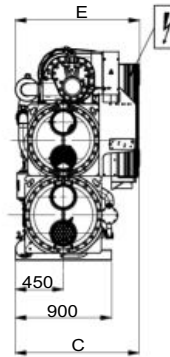
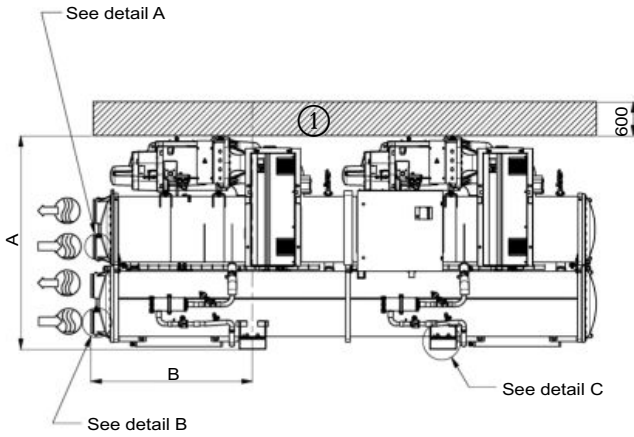

Dimensions in mm

	A	B	C	D	E	F	G	H
<b>30XW-VZE/30XWHVZE</b>								
<b>851</b>	1998	1514	1164	4730	1162	219,1	219,1	4500
<b>1001</b>	1998	1514	1164	4730	1162	219,1	219,1	4500
<b>1101</b>	2051	1514	1164	4730	1264	219,1	219,1	4500
<b>1201</b>	2051	1514	1164	4730	1264	219,1	219,1	4500
<b>1301</b>	2051	1514	1164	4730	1264	219,1	219,1	4500

**Legend**

All dimensions are given in mm

- Services clearances required
- Space required to remove
- Inlet water
- Outlet water
- Electrical supply entry

**NOTES:**

Drawings are not contractually binding. Before designing an installation, consult the certified dimensional drawings supplied with the unit or available on request.

For the positioning of the fixing points, weight distribution and centre of gravity coordinates please refer to the dimensional drawings.

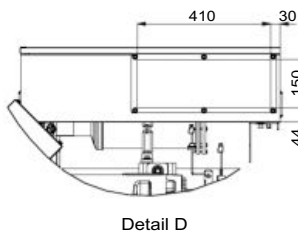
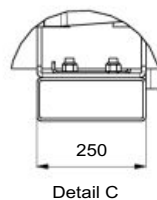
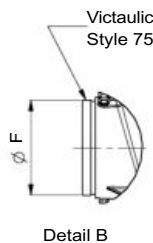
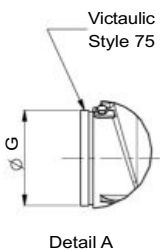

## WATER-COOLED SCREW CHILLERS



- Low energy consumption
- High reliability
- Easy and fast installation
- Low operating sound levels
- Environmental care

## 30XW/30XW-P



Nominal cooling capacity 269-1736 kW

The 30XW liquid chillers are the premium solution for industrial and commercial applications where installers, consultants and building owners require optimal performances and maximum quality.

The 30XW liquid chillers are designed to meet current and future requirements in terms of energy efficiency, flexibility of use and compactness. They use the most reliable technologies available today:

- Twin-rotor screw compressors with a variable capacity valve
- Refrigerant R134a
- Flooded heat exchangers that are mechanically cleanable
- Carrier SmartVu™ control with color touch screen user interface that includes 10 languages

To meet to all environmental and economic requirements, the 30XW is available in two efficiency classes:

- Entry-level efficiency 30XW units that offer an optimised balance of technical and economical aspects,
- Premium-efficiency 30XW-P units that offer unequalled energy efficiency to satisfy the most stringent demands of building owners wanting to reduce operating costs to the minimum.

The 30XW Aquaforce range is also split into two versions:

- 30XW for air conditioning and refrigeration applications
- 30XWH for heating applications

As standard, the unit can provide an evaporator leaving temperature down to 3,3°C (-12°C optional), and when operating as a heat pump, it can deliver up to 50°C (63°C optional) on the condenser side.



CARRIER participates in the ECP programme for LCP-HP  
Check ongoing validity of certificate:  
[www.eurovent-certification.com](http://www.eurovent-certification.com)

## CUSTOMER BENEFITS

### Low energy consumption

- SEPR up to 9,1 and SEER up to 7,7
- The high energy efficiency is reached through:
  - Twin-rotor screw compressor equipped with a high-efficiency motor and a variable capacity valve that permits exact matching of the cooling capacity to the load.
  - Flooded multi-pipe heat exchangers for increased heat exchange efficiency.
  - Electronic expansion device permitting operation at a lower condensing pressure and improved utilisation of the evaporator heat exchange surface.
  - Economizer system with electronic expansion device for increased cooling capacity (30XW-P).

### Low operating sound levels

- Standard unit features include:
  - Silencers on the compressors discharge line.
  - Silencers on the economiser return line.
  - Acoustic insulation on the components that are most subjected to radiated noise.
  - Option 257 further reduces the global unit sound level.

### Easy and fast installation

- Compact design
  - The 30XW units are designed to offer the most compact dimensions on the market.
  - With a width of approximately 1 m up to 1600 kW the units can pass through standard door openings and only require minimum floor space in the plant room.

**Compact, accessible unit - side view - sizes up to 1600 KW**

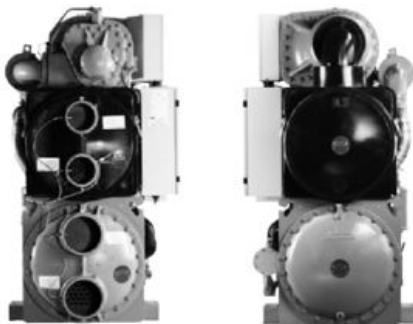

- Simplified electrical connections
  - Main disconnect switch with high trip capacity
  - Transformer to supply the integrated control circuit (400/24 V)
- Simplified hydraulic connections
  - Victaulic connections on the evaporator and condenser
  - Practical reference marks for entering and leaving water connections
  - Possibility to reverse the heat exchanger water inlet and outlet at the factory
  - Possibility to modify the number of heat exchanger passes
- Fast commissioning
  - Systematic factory operation test before shipment
  - Quick-test function for step-by-step verification of the instruments, expansion devices and compressors.

### Environmental care

- R-134a refrigerant
  - HFC refrigerant with zero ozone depletion potential
- Leak-tight refrigerant circuit
  - Reduction of leaks as no capillary tubes and flare connections are used
  - Verification of pressure transducers and temperature sensors without transferring refrigerant charge
  - Discharge line shut-off valve and liquid line service valve for simplified maintenance.

### High reliability and easy servicing

- The 30XW units offer increased global performance as well as Carrier's acclaimed product quality and reliability.
- Major components are selected and tested to minimize failures possibility, as well as many design choices have been taken in this perspective.
- Screw compressors
  - Industrial-type screw compressors with oversized bearings and motor cooled by suction gas.
  - All compressor components are easily accessible on site minimising down-time.
- Refrigerant circuit
  - Two independent refrigerant circuits (from 1000 kW upwards); the second one automatically takes over, if the first one develops a fault, maintaining partial cooling under all circumstances.
- Evaporator
  - Electronic paddle-free flow switch. Auto-setting according to cooler size and fluid type.
- Auto-adaptive control
  - Control algorithm prevents excessive compressor cycling (Carrier patent)
  - Automatic compressor unloading in case of abnormally high condensing pressure.
- Exceptional endurance tests
  - Partnerships with specialised laboratories and use of limit simulation tools (finite element calculation) for the design of critical components.
  - Transport simulation test in the laboratory on a vibrating table and then on an endurance circuit (based on a military standard).

## TECHNICAL INSIGHTS

### SmartVu™



- New innovative smart control features :
  - An intuitive and user-friendly, coloured, 4.3" interface
  - 1 languages available on choice: DE, EN, ES, FR, T, NL, PT, TR, TU + one additional customer choice
  - Screen-shots with concise and clear information in local languages
  - Complete menu, customised for different users (end user, service personnel and Carrier-factory technicians)
  - Setpoint offset based on the outside air temperature
  - Safe operation and unit setting: Password protection ensures that unauthorised people cannot modify any advanced parameters
  - Simple and "smart" intelligence uses data collection from the constant monitoring of all machine parameters to optimise unit operation
  - Night-mode: Cooling capacity management for reduced noise level.
  - With hydraulic module: Water pressure display and water flow rate calculation.
- Energy management :
  - Internal time schedule clock controls chiller on/off times and operation at a second set-point
  - The DCT (Data Collection Tool) records the alarms history to simplify and facilitate service operations.
- Maintenance functions :
  - F-Gas regulation leak check reminder alert
  - Maintenance alert can be configured to days, months or hours of operation
- Advanced communication features :
  - Easy and high-speed communication technology over Ethernet (IP) to a centralised building management system
  - Access to multiple unit parameters.

### Remote Management (Standard)

- Units with SmartVu™ control can be easily accessed from the internet, using a PC with an Ethernet connection. This makes remote control quick and easy and offers significant advantages for service operations.
- Aquaforce with Greenspeed® Intelligence is equipped with an RS485 serial port that offers multiple remote control, monitoring and diagnostic possibilities. When networked with other Carrier equipment through the CCN (Carrier Comfort Network - proprietary protocol), all components form a HVAC system fully-integrated and balanced through one of the Carrier's network system products, like the Chiller System anager or the Plant System anager (optional).
- The 30XW/P™ also communicates with other building management systems via optional communication gateways (BACnet, LON or JBus).
- The following commands/visualisations are possible from remote connection:
  - Start/Stop of the machine
  - Dual set-point management: Through a dedicated contact is possible to activate a second set-point (example, unoccupied mode)
  - Demand limit setting: To limit the maximum chiller capacity to a predefined value
  - Water pump control: These outputs control the contactors of one/two evaporator water pumps.
  - Water pumps changeover (only with hydraulic module options): These contacts are used to detect a water pump operation fault and automatically change over to the other pump.
  - Operation visualisation: indication if the unit is operating or if it is in stand-by (no cooling load)
  - Alarm visualisation.

### Remote management (EMM option)

- The Energy Management Module offers extended remote control possibilities:
  - Room temperature: Permits set-point reset based on the building indoor air temperature (if Carrier thermostats are installed)
  - Set-point reset: Allows reset of the cooling set-point based on a 4-20 mA or 0-10 V signal
  - Demand limit: Permits limitation of the maximum chiller capacity based on 0-10 V signal
  - Demand limit 1 and 2: Closing of these contacts limits the maximum chiller capacity to two predefined values.
  - User safety: This contact can be used for any customer safety loop; opening the contact generates a specific alarm.
  - Ice storage end: When ice storage has finished, this input permits return to the second set-point (unoccupied mode).
  - Time schedule override: Closing of this contact cancels the programmed time schedule.
  - Out of service: This signal indicates that the chiller is completely out of service.
  - Chiller capacity: This analogue output ( -1 gives an immediate indication of the chiller capacity.
  - Alert indication: This volt-free contact indicates the necessity to carry out a maintenance operation or the presence of a minor fault.
  - Compressors running status: Set of outputs (as many as the compressors number) indicating which compressors are running.

## TECHNICAL INSIGHTS

### 06T screw compressor

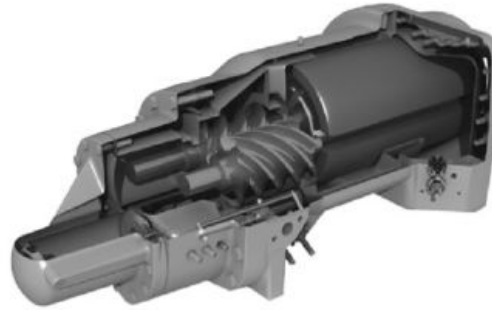

The new generation of the Carrier 06T screw compressors benefits from Carrier's long experience in the development of twin-rotor screw compressors. The compressor is equipped with bearings with oversized rollers, oil pressure lubricated for reliable and durable operation, even at maximum load.

A variable control valve controlled by the oil pressure permits infinitely variable cooling capacity. This system allows optimal adjustment of the compressor cooling capacity and ensures exceptionally high stability of the chilled water leaving temperature. Among the other advantages: if a fault occurs e.g. if the condenser is fouled or at very high water temperature, the compressor does not switch off, but continues operation with a reduced capacity (unloaded mode).

The silencer in the discharge line considerably reduces discharge gas pulsations for much quieter operation.

The condenser includes an oil separator that minimises the amount of oil in circulation in the refrigerant circuit and re-directs it to the compressor function.

### Digit number

1	2	3	4	5	6	7	8	9	1	1	1	1	1	1	1	1	1
3	0	X	W	-	-	0	2	5	4	B	0	0	0	0	1	-	

**Legend:**

- Digit 1 to 4 : Water-cooled chiller with screw compressor
- Digit 5 : Application type, - = Cooling, H = Heating
- Digit 6 : Efficiency, - = standard, P = premium
- Digit 7 to 10 : Model number based on cooling capacity in kW
- Digit 11 : Index for major product modification (visible impact for customer)
- Digit 12 to 15 : Counter used to generate a one time product code
- Digit 16 : Not used



OPTIONS

Options	No.	Description	Advantages	Use
Low Brine with turbulators down to -15°C	6	Redesigned evaporator including turbulators to allow chilled brine solution production with low pressure drops on the entire negative application range, down to -15°C (including turbulators, extra insulation and algorithms).	Covers specific applications such as ice storage and industrial processes	-0254-P1762
Light-brine solution, down to -3°C	8	Implementation of new control algorithms and redesigned evaporator to allow chilled brine solution production down to -3°C when ethylene glycol is used (0°C with propylene glycol)	Matches with most application requirements for ground-sourced heat pumps and fits with many industrial processes requirements	-0254-P1762
IP44 electrical protection level	20	Control box tightness reinforced Electrical box enclosure and outside electrical component following IEC 60529 standard	Permits unit installation in more severe environments	-0254-P1762
90-10 Copper-Nickel condensers	33	- Condenser tubes 90-10 Cu/Ni. - Condenser tube sheets clad with 90-10 Cu/Ni. - Waterboxes not treated against corrosion.	Improved resistance to corrosion	-0254-P1762
Unit supplied in two assembled parts	51	The unit is equipped with flanges that allow disassembly of the unit on site	Facilitates installation in plant rooms with limited access	-1652--1702, P1612-P1762
Master/slave operation	58	Unit equipped with supplementary water outlet temperature sensor kit (to be field installed) allowing master/slave operation of two units connected in parallel	Optimised operation of two units connected in parallel operation with operating time equalisation	-0254-P1762
Single power connection point	81	Unit power connection via one main supply connection	Quick and easy installation	-1002--1702, P1012-P1762
No disconnect switch	82A	Unit without disconnect switch, but with short-circuit protection device	Permits an external electrical disconnect system for the unit (field-supplied), while ensuring unit short circuit protection	-0254-P1762
Evap. single pump power/control circuit	84	Unit equipped with an electrical power and control circuit for one pump evaporator side	Quick and easy installation: the control of fixed speed pumps is embedded in the unit control	-0254--1252, P0512-P1314
Evap. dual pumps power/control circuit	84D	Unit equipped with an electrical power and control circuit for two pumps evaporator side	Quick and easy installation: the control of fixed speed pumps is embedded in the unit control	-0254--1252, P0512-P1314
Cond. single pump power/control circuit	84R	Unit equipped with an electrical power and control circuit for one pump condenser side	Quick and easy installation: the control of fixed speed pumps is embedded in the unit control	-0254--1252, P0512-P1314
Condenser insulation	86	Thermal condenser insulation	Minimizes thermal dispersions condenser side (key option for heat pump or heat recovery applications)	-0254-P1762
Service valve set	92	Liquid line valve (evaporator inlet) and compressor suction line valve	Allow isolation of various refrigerant circuit components for simplified service and maintenance	-0254-P1762
Evaporator with one pass less	100C	Evaporator with one pass on the water side. Evaporator inlet and outlet on opposite sides.	Easy to install, depending on site. Reduced pressure drops	-0254-P1762
Condenser with one pass less	102C	Condenser with one pass on the water side. Condenser inlet and outlet on opposite sides.	Easy to install, depending on site. Reduced pressure drops	-0254-P1762
21 bar evaporator	104	Reinforced evaporator for extension of the maximum water-side service pressure to 21 bar (standard 10 bar)	Covers applications with a high water column evaporator side (typically high buildings)	-0254-P1762
21 bar condenser	104A	Reinforced condenser for extension of the maximum water-side service pressure to 21 bar (standard 10 bar)	Covers applications with a high water column condenser side (typically high buildings)	-0254-P1762
Reversed evaporator water connections	107	Evaporator with reversed water inlet/outlet	Easy installation on sites with specific requirements	-0254-P1762
Reversed condenser water connections	107A	Condenser with reversed water inlet/outlet	Easy installation on sites with specific requirements	-0254-P1762
Lon gateway	148D	Bi-directional communication board complying with Lon Talk protocol	Connects the unit by communication bus to a building management system	-0254-P1762
Bacnet over IP	149	Bi-directional high-speed communication using BACnet protocol over Ethernet network (IP)	Easy and high-speed connection by ethernet line to a building management system. Allows access to multiple unit parameters	-0254-P1762
Modbus over IP and RS485	149B	Bi-directional high-speed communication using Modbus protocol over Ethernet network (IP)	Easy and high-speed connection by ethernet line to a building management system. Allows access to multiple unit parameters	-0254-P1762
High condensing temperature	150	Optimized compressor for operation at high condensing temperature	Increased condenser leaving water temperature up to 63°C. Allows applications with high condensing temperature (heat pumps, installations with not generously sized dry-coolers or more generally, installations with dry-coolers in hot climate). NOTE: to ens	-0254--0354, P0512-P1762

## OPTIONS

Options	No.	Description	Advantages	Use
Condensing temperature limitation	150B	Limitation of the maximum condenser leaving water temperature to 45°C	Reduced maximum power input and current absorption: power cables and protection elements can therefore be downsized	-0254-P1762
Control for low cond. temperature	152	Output signal (0-10 V) to control the condenser water inlet valve	Simple installation: for applications with cold water at condenser inlet (ex. ground-source, groundwater-source, superficial water-source applications) the signal permits to control a 2 or 3-way valve to maintain condenser water temperature (and so condensing pressure) at acceptable values	-0254-P1762
Dry-cooler control	154	Adaptation of the control box for communication with the dry-cooler via a bus. For dry cooler need to select the cabinet with option control cabinet manage by the chiller control	Easy system management, extended control capabilities of a remote dry-cooler	-0254-P1762
Energy Management Module	156	EMM Control board with additional inputs/outputs. See Energy Management Module option chapter	Extended remote control capabilities (Set-point reset, ice storage end, demand limits, boiler on/off command...)	-0254-P1762
7" user interface	158A	Control supplied with a 7 inch colour touch screen user interface	Enhanced ease of use.	-0254-P1762
Input contact for Refrigerant leak detection	159	0-10 V signal to report any refrigerant leakage in the unit directly on the controller (the leak detector itself must be supplied by the customer)	Immediate customer notification of refrigerant losses to the atmosphere, allowing timely corrective actions	-0254-P1762
Dual relief valves on 3-way valve	194	Three-way valve upstream of dual relief valves on the shell and tubes evaporator	Valve replacement and inspection facilitated without refrigerant loss. Comforms to European standard EN378/BGVD4	-0254-P1762
Compliance with Swiss regulations	197	Additional tests on the water heat exchangers: supply (additional of PED documents) supplementary certificates and test certifications	Conformance with Swiss regulations	-0254-P1762
Compliance with Russian regulations	199	EAC certification	Conformance with Russian regulations	-0254-P1762
Compliance with Australian regulations	200	Unit approved to Australian code	Conformance with Australian regulations	-0254-P1762
Low noise level	257	Evaporator sound insulation	3 dB(A) quieter than standard unit	-0402-P1762
Welded evaporator connection kit	266	Victaulic piping connections with welded joints	Easy installation	-0254-P1762
Welded condenser water connection kit	267	Victaulic piping connections with welded joints	Easy installation	-0254-P1762
Flanged evaporator water connection kit	268	Victaulic piping connections with flanged joints	Easy installation	-0254-P1762
Flanged condenser water connection kit	269	Victaulic piping connections with flanged joints	Easy installation	-0254-P1762
Thermal compressor insulation	271	The compressor is covered with a thermal insulation layer	Prevents air humidity to condensate on the compressor surface	-0254-P1762
230V electrical plug	284	230V AC power supply source provided with plug socket and transformer (180 VA, 0,8 Amps)	Permits connection of a laptop or an electrical device during unit commissioning or servicing	-0254-P1762
Free-cooling dry-cooler control	313	Control & connections to a Free Cooling Drycooler 09PE or 09VE fitted with option FC control box	Easy system management, Extended control capabilities to a drycooler used in Free Cooling mode	-0254-P1762
Compliance with UAE regulation	318	Additional label on the unit with rated power input, rated current and EER following AHRI 550/590	Compliance with ESMA standard UAE.S 5010-5:2019.	-0254-P1762
Compliance with Morocco regulation	327	Specifics documents according Morocco regulation	Conformance with Morocco regulations	-0254-P1762

## PHYSICAL DATA, STANDARD UNITS

### Standard-efficiency units

30XW--/30XWH-		254	304	354	402	452	552	602	652	702	802		
<b>Heating</b>													
<b>Standard unit Full load performances*</b>	HW1	Nominal capacity	kW	317	360	422	499	555	626	633	793	858	929
		COP	kW/kW	5,96	5,98	5,93	5,98	6,04	5,84	5,81	6,06	5,96	5,79
	HW2	Nominal capacity	kW	312	353	417	473	526	595	624	749	812	879
		COP	kW/kW	4,51	4,50	4,55	4,54	4,56	4,42	4,46	4,54	4,48	4,40
Seasonal energy efficiency**	HW1	SCOP <sub>30/35°C</sub>	kWh/kWh	5,98	6,02	5,99	6,45	6,60	6,58	6,31	6,16	6,15	6,13
		$\eta_s$ heat <sub>30/35°C</sub>	%	231	233	231	250	256	255	245	238	238	237
		P <sub>rated</sub>	kW	414	426	500	595	660	742	750	945	1022	1095
<b>Cooling</b>													
<b>Standard unit Full load performances*</b>	CW1	Nominal capacity	kW	269	303	354	421	467	525	531	669	720	783
		EER	kW/kW	5,25	5,23	5,17	5,22	5,28	5,12	5,11	5,32	5,23	5,13
	CW2	Nominal capacity	kW	264	320	396	525	566	520	596	753	788	782
		EER	kW/kW	7,30	5,74	6,31	6,50	6,40	5,24	5,86	6,02	5,76	5,22
Seasonal energy efficiency**		<b>SEER<sub>12/7°C</sub> Comfort low temp.</b>	<b>kWh/kWh</b>	<b>6,26</b>	<b>6,33</b>	<b>6,40</b>	<b>6,851</b>	<b>7,043</b>	<b>7,116</b>	<b>6,823</b>	<b>6,644</b>	<b>6,63</b>	<b>6,82</b>
		$\eta_s$ cool <sub>12/7°C</sub>	%	<b>247</b>	<b>250</b>	<b>253</b>	<b>271</b>	<b>279</b>	<b>282</b>	<b>270</b>	<b>263</b>	<b>262</b>	<b>270</b>
		SEPR <sub>12/7°C</sub> Process high temp.	kWh/kWh	8,60	8,16	8,80	8,12	8,28	7,72	7,90	8,83	8,25	8,01
Integrated Part Load Value	IPLV.SI	kW/kW	6,791	6,845	6,850	6,861	7,165	7,430	7,110	7,185	7,168	7,212	
<b>Sound levels - standard unit</b>													
Sound power level <sup>(1)</sup>		dB(A)	95	95	95	99	99	99	99	99	99	99	
Sound pressure level at 1 m <sup>(2)</sup>		dB(A)	78	78	78	82	82	82	82	82	82	82	
<b>Sound levels - standard unit + option 257<sup>(3)</sup></b>													
Sound power level <sup>(1)</sup>		dB(A)	-	-	-	96	96	96	96	96	96	96	
Sound pressure level at 1 m <sup>(2)</sup>		dB(A)	-	-	-	78	78	78	78	78	78	78	
<b>Dimensions - standard unit</b>													
Length		mm	2724	2724	2724	2741	2741	2741	2741	3059	3059	3059	
Width		mm	928	928	928	936	936	936	936	1040	1040	1040	
Height		mm	1567	1567	1567	1692	1692	1692	1692	1848	1848	1848	
Operating weight <sup>(4)</sup>		kg	2017	2036	2072	2575	2575	2613	2644	3247	3266	3282	
<b>Compressors</b>													
Semi-hermetic 06T screw compressors, 50 r/s													
Circuit A		-	1	1	1	1	1	1	1	1	1	1	
Circuit B		-	-	-	-	-	-	-	-	-	-	-	

\* In accordance with standard EN14511-3:2022.  
 \*\* In accordance with standard EN14825:2022, average climate  
 HW1 Heating mode conditions: Evaporator entering/leaving water temperature 10°C/7°C, condenser entering/leaving water temperature 30°C/35°C, evaporator and condenser fouling factor 0 m<sup>2</sup>. k/W  
 HW2 Heating mode conditions: Evaporator entering/leaving water temperature 10°C/7°C, condenser entering/leaving water temperature 40°C/45°C, evaporator and condenser fouling factor 0 m<sup>2</sup>. k/W  
 CW1 Cooling mode conditions: Evaporator water entering/leaving temperature 12°C/7°C, condenser entering/leaving water temperature 30°C/35°C, evaporator and condenser fouling factor 0 m<sup>2</sup>.K/W  
 CW2 Cooling mode conditions: Evaporator water entering/leaving temperature 23°C/18°C, condenser entering/leaving water temperature 30°C/35°C, evaporator and condenser fouling factor 0 m<sup>2</sup>.K/W  
 $\eta_s$  heat<sub>30/35°C</sub> & SCOP<sub>30/35°C</sub> Values calculated in accordance with EN14825:2022  
 $\eta_s$  cool<sub>12/7°C</sub> & SEER<sub>12/7°C</sub> **Bold values compliant to Ecodesign regulation: (EU) No 2016/2281 for Comfort application**  
 SEPR<sub>12/7°C</sub> Values calculated in accordance with EN14825:2022  
 IPLV.SI Calculations according to standard performances AHRI 551-591 (SI).  
 (1) In dB ref=10<sup>-12</sup> W, (A) weighting. Declared dualnumber noise emission values in accordance with ISO 4871 (with an associated uncertainty of +/-3dB(A)). Measured in accordance with ISO 9614-1 and certified by Eurovent.  
 (2) In dB ref 20µPa, (A) weighting. Declared dualnumber noise emission values in accordance with ISO 4871 (with an associated uncertainty of +/-3dB(A)). For information, calculated from the sound power level Lw(A).  
 (3) Option 257 = Low noise level.  
 (4) Weight shown is guideline only. Please refer to the unit nameplate.



Eurovent certified values



AHRI certified values  
30XW-only

## PHYSICAL DATA, STANDARD UNITS

### Standard-efficiency units

30XW--/30XWH-		254	304	354	402	452	552	602	652	702	802
<b>Refrigerant (4)</b>		R-134a									
Circuit A	kg	84	80	78	92	92	92	92	145	135	125
	teqCO <sub>2</sub>	120	114	112	132	132	132	132	207	193	179
Circuit B	kg	-	-	-	-	-	-	-	-	-	-
	teqCO <sub>2</sub>	-	-	-	-	-	-	-	-	-	-
<b>Oil - standard unit</b>											
Circuit A	l	23,5	23,5	23,5	32	32	32	32	36	36	36
Circuit B	l	-	-	-	-	-	-	-	-	-	-
<b>Capacity control</b>		SmartVu™, electronic expansion valves (EXV)									
Minimum capacity (5)	%	15	15	30	30	30	30	30	15	15	30
<b>Evaporator</b>		Multi-pipe flooded type									
Water volume	l	50	56	61	70	70	70	70	109	109	109
Water connections (Victaulic)	in	5	5	5	5	5	5	5	6	6	6
Drain and vent connections (NPT)	in	3/8	3/8	3/8	3/8	3/8	3/8	3/8	3/8	3/8	3/8
Max. water-side operating pressure	kPa	1000	1000	1000	1000	1000	1000	1000	1000	1000	1000
<b>Condenser</b>		Multi-pipe flooded type									
Water volume	l	55	55	55	76	76	76	76	109	109	109
Water connections (Victaulic)	in	5	5	5	5	5	5	5	6	6	6
Drain and vent connections (NPT)	in	3/8	3/8	3/8	3/8	3/8	3/8	3/8	3/8	3/8	3/8
Max. water-side operating pressure	kPa	1000	1000	1000	1000	1000	1000	1000	1000	1000	1000

(4) Weight shown is guideline only. Please refer to the unit nameplate.

(5) Minimum unit capacity corresponds to a physical state of the unit and is given for indication only. The actual capacity at this stage depends on operating conditions.

## PHYSICAL DATA, STANDARD UNITS

### Standard-efficiency units

30XW--/30XWH-			852	1002	1052	1154	1252	1352	1452	1552	1652	1702	
<b>Heating</b>													
<b>Standard unit Full load performances*</b>	HW1	Nominal capacity	kW	981	1185	1237	1324	1457	1557	1689	1795	1913	2001
		COP	kW/kW	5,98	5,77	5,67	5,79	6,12	5,96	5,76	5,61	5,94	5,92
	HW2	Nominal capacity	kW	958	1123	1174	1297	1375	1466	1592	1687	1867	1948
		COP	kW/kW	4,60	4,40	4,33	4,46	4,63	4,53	4,41	4,33	4,61	4,64
Seasonal energy efficiency**	HW1	SCOP <sub>30/35°C</sub>	kWh/kWh	6,33	6,43	6,24	6,30	6,56	6,33	6,22	6,11	6,46	6,50
		η <sub>s heat 30/35°C</sub>	%	245	249	242	244	254	245	241	236	251	252
		P <sub>rated</sub>	kW	1153	1411	1473	1569	1737	1856	2013	2140	2265	2371
<b>Cooling</b>													
<b>Standard unit Full load performances*</b>	CW1	Nominal capacity	kW	829	1005	1049	1128	1242	1327	1438	1532	1637	1712
		EER	kW/kW	5,33	5,19	5,12	5,25	5,55	5,45	5,31	5,24	5,54	5,55
	CW2	Nominal capacity	kW	828	1188	1322	1220	1535	1677	1753	1865	1726	1830
		EER	kW/kW	5,43	6,93	6,30	5,75	6,72	6,71	6,30	6,36	5,95	5,91
Seasonal energy efficiency**		<b>SEER<sub>12/7°C</sub> Comfort low temp.</b>	<b>kWh/kWh</b>	<b>7,091</b>	<b>7,07</b>	<b>7,02</b>	<b>6,96</b>	<b>7,51</b>	<b>7,24</b>	<b>7,11</b>	<b>7,13</b>	<b>7,55</b>	<b>7,69</b>
		η <sub>s cool 12/7°C</sub>	%	<b>281</b>	<b>280</b>	<b>278</b>	<b>275</b>	<b>298</b>	<b>287</b>	<b>282</b>	<b>282</b>	<b>299</b>	<b>304</b>
		SEPR <sub>12/7°C</sub> Process high temp.	kWh/kWh	8,01	8,29	8,11	7,96	8,97	9,09	8,34	8,13	8,45	8,50
Integrated Part Load Value	IPLV.SI	kW/kW	7,289	7,478	7,367	7,435	7,804	7,725	7,666	7,504	8,000	8,020	
<b>Sound levels - standard unit</b>													
Sound power level <sup>(1)</sup>		dB(A)	99	102	102	102	102	102	102	102	102	102	
Sound pressure level at 1 m <sup>(2)</sup>		dB(A)	82	84	84	84	83	83	83	83	83	83	
<b>Sound levels - standard unit + option 257<sup>(3)</sup></b>													
Sound power level <sup>(1)</sup>		dB(A)	96	99	99	99	99	99	99	99	99	99	
Sound pressure level at 1 m <sup>(2)</sup>		dB(A)	78	80	80	80	80	80	80	80	80	80	
<b>Dimensions - standard unit</b>													
Length		mm	2780	4025	4025	4025	4730	4730	4730	4730	4790	4790	
Width		mm	1042	1036	1036	1036	1156	1156	1156	1156	1902	1902	
Height		mm	1898	1870	1870	1925	2051	2051	2051	2051	1515	1515	
Operating weight <sup>(4)</sup>		kg	3492	5370	5408	5698	7066	7267	7305	7337	8681	8699	
<b>Compressors</b> Semi-hermetic 06T screw compressors, 50 r/s													
Circuit A		-	1	1	1	1	1	1	1	1	1	1	
Circuit B		-	-	1	1	1	1	1	1	1	1	1	

\* In accordance with standard EN14511-3:2022.  
 \*\* In accordance with standard EN14825:2022, average climate  
 HW1 Heating mode conditions: Evaporator entering/leaving water temperature 10°C/7°C, condenser entering/leaving water temperature 30°C/35°C, evaporator and condenser fouling factor 0 m<sup>2</sup>. k/W  
 HW2 Heating mode conditions: Evaporator entering/leaving water temperature 10°C/7°C, condenser entering/leaving water temperature 40°C/45°C, evaporator and condenser fouling factor 0 m<sup>2</sup>. k/W  
 CW1 Cooling mode conditions: Evaporator water entering/leaving temperature 12°C/7°C, condenser entering/leaving water temperature 30°C/35°C, evaporator and condenser fouling factor 0 m<sup>2</sup>.K/W  
 CW2 Cooling mode conditions: Evaporator water entering/leaving temperature 23°C/18°C, condenser entering/leaving water temperature 30°C/35°C, evaporator and condenser fouling factor 0 m<sup>2</sup>.K/W  
 η<sub>s heat 30/35°C</sub> & SCOP<sub>30/35°C</sub> Values calculated in accordance with EN14825:2022  
 η<sub>s cool 12/7°C</sub> & SEER<sub>12/7°C</sub> **Bold values compliant to Ecodesign regulation: (EU) No 2016/2281 for Comfort application**  
 SEPR<sub>12/7°C</sub> Values calculated in accordance with EN14825:2022  
 IPLV.SI Calculations according to standard performances AHRI 551-591 (SI).  
 (1) In dB ref=10<sup>-12</sup> W, (A) weighting. Declared dualnumber noise emission values in accordance with ISO 4871 (with an associated uncertainty of +/-3dB(A)). Measured in accordance with ISO 9614-1 and certified by Eurovent.  
 (2) In dB ref 20μPa, (A) weighting. Declared dualnumber noise emission values in accordance with ISO 4871 (with an associated uncertainty of +/-3dB(A)). For information, calculated from the sound power level Lw(A).  
 (3) Option 257 = Low noise level.  
 (4) Weight shown is guideline only. Please refer to the unit nameplate.



Eurovent certified values



AHRI certified values  
30XW-only



## PHYSICAL DATA, STANDARD UNITS

### Standard-efficiency units

30XW--/30XWH-		852	1002	1052	1154	1252	1352	1452	1552	1652	1702
<b>Refrigerant (4)</b>		R-134a									
Circuit A	kg	158	85	85	105	120	115	110	105	195	195
	teqCO <sub>2</sub>	226	122	122	150	172	164	157	150	279	279
Circuit B	kg	-	85	85	105	120	115	110	105	195	195
	teqCO <sub>2</sub>	-	122	122	150	172	164	157	150	279	279
<b>Oil - standard unit</b>											
Circuit A	l	36	32	32	32	36	36	36	36	36	36
Circuit B	l	-	32	32	32	32	36	36	36	36	36
<b>Capacity control</b>		SmartVu™, electronic expansion valves (EXV)									
Minimum capacity (5)	%	30	30	30	30	15	15	15	30	30	30
<b>Evaporator</b>		Multi-pipe flooded type									
Water volume	l	98	182	182	205	301	301	301	301	354	354
Water connections (Victaulic)	in	6	6	6	8	8	8	8	8	8	8
Drain and vent connections (NPT)	in	3/8	3/8	3/8	3/8	3/8	3/8	3/8	3/8	3/8	3/8
Max. water-side operating pressure	kPa	1000	1000	1000	1000	1000	1000	1000	1000	1000	1000
<b>Condenser</b>		Multi-pipe flooded type									
Water volume	l	137	193	193	193	340	340	340	340	426	426
Water connections (Victaulic)	in	8	8	8	8	8	8	8	8	8	8
Drain and vent connections (NPT)	in	3/8	3/8	3/8	3/8	3/8	3/8	3/8	3/8	3/8	3/8
Max. water-side operating pressure	kPa	1000	1000	1000	1000	1000	1000	1000	1000	1000	1000

(4) Weight shown is guideline only. Please refer to the unit nameplate.

(5) Minimum unit capacity corresponds to a physical state of the unit and is given for indication only. The actual capacity at this stage depends on operating conditions.

## PHYSICAL DATA, STANDARD UNITS

### High-efficiency units

30XW-P/30XWHP			512	562	712	812	862	1012	1162	1314	1464	1612	1762	
<b>Heating</b>														
<b>Standard unit Full load performances*</b>	HW1	Nominal capacity	kW	586	667	851	912	995	1201	1327	1522	1680	1863	2019
		COP	kW/kW	6,36	6,30	6,52	6,29	6,27	6,35	6,24	6,29	6,06	6,38	6,27
	HW2	Nominal capacity	kW	573	654	836	896	970	1179	1296	1489	1643	1823	1964
		COP	kW/kW	4,82	4,78	4,92	4,74	4,78	4,85	4,77	4,82	4,66	4,84	4,81
Seasonal energy efficiency**	HW1	SCOP <sub>30/35°C</sub>	kWh/kWh	6,58	6,59	6,48	6,27	6,48	6,72	6,85	6,75	6,38	6,73	6,71
		ηs heat <sub>30/35°C</sub>	%	255	256	251	243	251	261	266	262	247	261	260
		P <sub>rated</sub>	kW	694	791	1009	1081	1180	1424	1572	1805	1993	2210	2395
<b>Cooling</b>														
<b>Standard unit Full load performances*</b>	CW1	Nominal capacity	kW	502	569	727	776	850	1025	1143	1308	1435	1606	1736
		EER	kW/kW	5,63	5,57	5,75	5,55	5,59	5,67	5,71	5,74	5,53	5,80	5,72
	CW2	Nominal capacity	kW	546	643	788	859	886	1217	1251	1554	1687	1802	1865
		EER	kW/kW	6,36	6,38	6,62	6,44	6,28	7,29	6,30	8,19	6,69	6,75	6,54
Seasonal energy efficiency**		<b>SEER<sub>12/7°C</sub> Comfort low temp.</b>	<b>kWh/kWh</b>	<b>7,00</b>	<b>7,12</b>	<b>7,05</b>	<b>6,82</b>	<b>7,24</b>	<b>7,34</b>	<b>7,78</b>	<b>7,69</b>	<b>7,29</b>	<b>7,79</b>	<b>7,86</b>
		ηs cool <sub>12/7°C</sub>	%	277	282	279	270	287	291	308	304	289	309	311
		SEPR <sub>12/7°C</sub> Process high temp.	kWh/kWh	8,42	8,50	9,23	8,33	8,54	8,50	8,85	9,00	8,89	8,82	8,83
Integrated Part Load Value	IPLV.SI	kW/kW	7,391	7,473	7,556	7,301	7,538	7,639	8,053	8,150	7,485	7,757	8,089	
<b>Sound levels - standard unit</b>														
Sound power level (1)		dB(A)	99	99	99	99	99	102	102	102	102	102	102	
Sound pressure level at 1 m (2)		dB(A)	82	82	81	81	81	83	83	83	83	83	83	
<b>Sound levels - standard unit + option 257(3)</b>														
Sound power level (1)		dB(A)	96	96	96	96	96	99	99	99	99	99	99	
Sound pressure level at 1 m (2)		dB(A)	78	78	78	78	78	80	80	80	80	80	80	
<b>Dimensions - standard unit</b>														
Length		mm	3059	3059	3290	3290	3290	4730	4730	4730	4730	4832	4832	
Width		mm	936	936	1069	1069	1069	1039	1039	1162	1162	2129	2129	
Height		mm	1743	1743	1950	1950	1950	1997	1997	2051	2051	1562	1562	
Operating weight (4)		kg	2981	3020	3912	3947	3965	6872	6950	7542	7752	10910	10946	
<b>Compressors</b>														
Semi-hermetic 06T screw compressors, 50 r/s														
Circuit A		-	1	1	1	1	1	1	1	1	1	1	1	
Circuit B		-	-	-	-	-	-	1	1	1	1	1	1	

\* In accordance with standard EN14511-3:2022.  
 \*\* In accordance with standard EN14825:2022, average climate  
 HW1 Heating mode conditions: Evaporator entering/leaving water temperature 10°C/7°C, condenser entering/leaving water temperature 30°C/35°C, evaporator and condenser fouling factor 0 m<sup>2</sup>. k/W  
 HW2 Heating mode conditions: Evaporator entering/leaving water temperature 10°C/7°C, condenser entering/leaving water temperature 40°C/45°C, evaporator and condenser fouling factor 0 m<sup>2</sup>. k/W  
 CW1 Cooling mode conditions: Evaporator water entering/leaving temperature 12°C/7°C, condenser entering/leaving water temperature 30°C/35°C, evaporator and condenser fouling factor 0 m<sup>2</sup>.K/W  
 CW2 Cooling mode conditions: Evaporator water entering/leaving temperature 23°C/18°C, condenser entering/leaving water temperature 30°C/35°C, evaporator and condenser fouling factor 0 m<sup>2</sup>.K/W  
 ηs heat<sub>30/35°C</sub> & SCOP<sub>30/35°C</sub> Values calculated in accordance with EN14825:2022  
 ηs cool<sub>12/7°C</sub> & SEER<sub>12/7°C</sub> **Bold values compliant to Ecodesign regulation: (EU) No 2016/2281 for Comfort application**  
 SEPR<sub>12/7°C</sub> Values calculated in accordance with EN14825:2022  
 IPLV.SI Calculations according to standard performances AHRI 551-591 (SI).  
 (1) In dB ref=10<sup>-12</sup> W, (A) weighting. Declared dualnumber noise emission values in accordance with ISO 4871 (with an associated uncertainty of +/-3dB(A)). Measured in accordance with ISO 9614-1 and certified by Eurovent.  
 (2) In dB ref 20μPa, (A) weighting. Declared dualnumber noise emission values in accordance with ISO 4871 (with an associated uncertainty of +/-3dB(A)). For information, calculated from the sound power level Lw(A).  
 (3) Option 257 = Low noise level.  
 (4) Weight shown is guideline only. Please refer to the unit nameplate.



Eurovent certified values



AHRI certified values 30XW-only

## PHYSICAL DATA, STANDARD UNITS

### High-efficiency units

30XW-P/30XWHP		512	562	712	812	862	1012	1162	1314	1464	1612	1762
<b>Refrigerant</b> <sup>(4)</sup>		R-134a										
Circuit A	kg	130	130	180	175	177	120	120	130	130	240	250
	teqCO <sub>2</sub>	186	186	257	250	253	172	172	186	186	343	358
Circuit B	kg	-	-	-	-	-	120	120	150	130	240	250
	teqCO <sub>2</sub>	-	-	-	-	-	172	172	215	186	343	358
<b>Oil - standard unit</b>												
Circuit A	l	32	32	36	36	36	32	32	36	36	36	36
Circuit B	l	-	-	-	-	-	32	32	32	36	36	36
<b>Capacity control</b>		SmartVu™, electronic expansion valves (EXV)										
Minimum capacity <sup>(5)</sup>	%	30	30	15	15	30	30	30	15	15	15	30
<b>Evaporator</b>		Multi-pipe flooded type										
Water volume	l	101	101	154	154	154	293	293	321	321	473	473
Water connections (Victaulic)	in	6	6	8	8	8	8	8	8	8	10	10
Drain and vent connections (NPT)	in	3/8	3/8	3/8	3/8	3/8	3/8	3/8	3/8	3/8	3/8	3/8
Max. water-side operating pressure	kPa	1000	1000	1000	1000	1000	1000	1000	1000	1000	1000	1000
<b>Condenser</b>		Multi-pipe flooded type										
Water volume	l	103	103	148	148	148	316	316	340	340	623	623
Water connections (Victaulic)	in	6	6	8	8	8	8	8	8	8	10	10
Drain and vent connections (NPT)	in	3/8	3/8	3/8	3/8	3/8	3/8	3/8	3/8	3/8	3/8	3/8
Max. water-side operating pressure	kPa	1000	1000	1000	1000	1000	1000	1000	1000	1000	1000	1000

(4) Weight shown is guideline only. Please refer to the unit nameplate.

(5) Minimum unit capacity corresponds to a physical state of the unit and is given for indication only. The actual capacity at this stage depends on operating conditions.

## ELECTRICAL DATA, STANDARD UNITS

### Standard-efficiency units

30XW--/30XWH-		254	304	354	402	452	552	602	652	702	802
<b>Power circuit</b>											
Nominal power supply	V-ph-Hz	400-3-50									
Voltage range	V	360-440									
<b>Control circuit</b>											
24 V via the built-in transformer											
<b>Nominal start-up current (1)</b>											
Circuit A	A	233	233	303	414	414	414	414	587	587	587
Circuit B	A	-	-	-	-	-	-	-	-	-	-
Option 81	A	-	-	-	-	-	-	-	-	-	-
<b>Maximum start-up current (2)</b>											
Circuit A	A	233	233	303	414	414	414	414	587	587	587
Circuit B	A	-	-	-	-	-	-	-	-	-	-
Option 81	A	-	-	-	-	-	-	-	-	-	-
<b>Cosine phi</b>											
Nominal (3)		0,83	0,85	0,83	0,87	0,88	0,89	0,89	0,88	0,89	0,90
Maximum (4)		0,89	0,89	0,88	0,90	0,90	0,91	0,91	0,90	0,91	0,92
Total harmonic distortion (4)	%	0	0	0	0	0	0	0	0	0	0
<b>Maximum power input†</b>											
Circuit A	kW	76	89	97	128	135	151	151	184	200	223
Circuit B	kW	-	-	-	-	-	-	-	-	-	-
Option 81	kW	-	-	-	-	-	-	-	-	-	-
<b>Nominal current drawn (3)</b>											
Circuit A	A	84	96	113	136	144	162	162	193	214	232
Circuit B	A	-	-	-	-	-	-	-	-	-	-
Option 81	A	-	-	-	-	-	-	-	-	-	-
<b>Maximum current drawn (Un)†</b>											
Circuit A	A	123	145	160	206	217	242	242	295	317	351
Circuit B	A	-	-	-	-	-	-	-	-	-	-
Option 81	A	-	-	-	-	-	-	-	-	-	-
<b>Maximum current drawn (Un -10%) (4)</b>											
Circuit A	A	138	162	178	218	230	260	260	304	340	358
Circuit B	A	-	-	-	-	-	-	-	-	-	-
Option 81	A	-	-	-	-	-	-	-	-	-	-
<b>Maximum power input with option 150B†</b>											
Circuit A	kW	67	79	87	114	118	133	134	173	183	205
Circuit B	kW	-	-	-	-	-	-	-	-	-	-
Option 81	kW	-	-	-	-	-	-	-	-	-	-
<b>Maximum current drawn (Un) with option 150B†</b>											
Circuit A	A	109	129	142	183	191	212	212	278	290	325
Circuit B	A	-	-	-	-	-	-	-	-	-	-
Option 81	A	-	-	-	-	-	-	-	-	-	-

(1) Instantaneous start-up current (maximum operating current of the smallest compressor(s) + locked rotor current or reduced start-up current of the largest compressor). Values obtained at standard Eurovent unit operating conditions: evaporator entering/leaving water temperature = 12°C/7°C, condenser entering/leaving water temperature = 30°C/35°C.

(2) Instantaneous start-up current (maximum operating current of the smallest compressor(s) + locked rotor current or reduced start-up current of the largest compressor). Values obtained at operation with maximum unit power input.

(3) Values obtained at standard Eurovent unit operating conditions: evaporator entering/leaving water temperature = 12°C/7°C, condenser entering/leaving water temperature = 30°C/35°C.

(4) Values obtained at operation with maximum unit power input.

† Values obtained at operation with maximum unit power input. Values given on the unit name plate.

## ELECTRICAL DATA, STANDARD UNITS

### Standard-efficiency units

30XW--/30XWH-		852	1002	1052	1154	1252	1352	1452	1552	1652	1702
<b>Power circuit</b>											
Nominal power supply	V-ph-Hz	400-3-50									
Voltage range	V	360-440									
<b>Control circuit</b>											
24 V via the built-in transformer											
<b>Nominal start-up current (1)</b>											
Circuit A	A	587	414	414	414	587	587	587	587	587	587
Circuit B	A	-	414	414	414	414	587	587	587	587	587
Option 81	A	-	558	574	574	747	780	801	819	819	819
<b>Maximum start-up current (2)</b>											
Circuit A	A	587	414	414	414	587	587	587	587	587	587
Circuit B	A	-	414	414	414	414	587	587	587	587	587
Option 81	A	-	631	656	656	829	882	904	938	938	938
<b>Cosine phi</b>											
Nominal (3)		0,90	0,88	0,89	0,89	0,88	0,88	0,89	0,9	0,9	0,9
Maximum (4)		0,92	0,90	0,91	0,91	0,90	0,90	0,91	0,92	0,92	0,92
Total harmonic distortion (4)	%	0	0	0	0	0	0	0	0	0	0
<b>Maximum power input†</b>											
Circuit A	kW	223	150	151	151	184	184	200	223	223	223
Circuit B	kW	-	135	151	151	151	184	200	223	202	223
Option 81	kW	-	284	301	301	334	367	399	447	425	447
<b>Nominal current drawn (3)</b>											
Circuit A	A	232	162	162	162	193	193	214	232	232	232
Circuit B	A	-	144	162	162	162	193	214	232	214	232
Option 81	A	-	306	324	324	355	386	427	464	446	464
<b>Maximum current drawn (Un)†</b>											
Circuit A	A	351	242	242	242	295	295	317	351	351	351
Circuit B	A	-	217	242	242	242	295	317	351	317	351
Option 81	A	-	459	484	484	537	590	634	702	668	702
<b>Maximum current drawn (Un -10%) (4)</b>											
Circuit A	A	358	260	260	260	304	304	340	358	358	358
Circuit B	A	-	230	260	260	260	304	340	358	340	358
Option 81	A	-	490	520	520	564	608	680	716	698	716
<b>Maximum power input with option 150B†</b>											
Circuit A	kW	205	133	133	133	173	173	183	207	207	207
Circuit B	kW	-	118	133	133	133	173	183	207	185	207
Option 81	kW	-	251	265	265	305	346	365	414	391	414
<b>Maximum current drawn (Un) with option 150B†</b>											
Circuit A	A	325	212	212	212	278	278	290	325	325	325
Circuit B	A	-	191	212	212	212	278	290	325	290	325
Option 81	A	-	403	424	424	490	556	580	650	615	650

(1) Instantaneous start-up current (maximum operating current of the smallest compressor(s) + locked rotor current or reduced start-up current of the largest compressor). Values obtained at standard Eurovent unit operating conditions: evaporator entering/leaving water temperature = 12°C/7°C, condenser entering/leaving water temperature = 30°C/35°C.

(2) Instantaneous start-up current (maximum operating current of the smallest compressor(s) + locked rotor current or reduced start-up current of the largest compressor). Values obtained at operation with maximum unit power input.

(3) Values obtained at standard Eurovent unit operating conditions: evaporator entering/leaving water temperature = 12°C/7°C, condenser entering/leaving water temperature = 30°C/35°C

(4) Values obtained at operation with maximum unit power input.

† Values obtained at operation with maximum unit power input. Values given on the unit name plate.



## ELECTRICAL DATA, STANDARD UNITS

### High-efficiency units

30XW-P/30XWHP		512	562	712	812	862	1012	1162	1314	1464	1612	1762
<b>Power circuit</b>												
Nominal power supply	V-ph-Hz	400-3-50										
Voltage range	V	360-440										
<b>Control circuit</b>												
24 V via the built-in transformer												
<b>Nominal start-up current (1)</b>												
Circuit A	A	414	414	587	587	587	414	414	587	587	587	587
Circuit B	A	-	-	-	-	-	414	414	414	587	587	587
Option 81	A	-	-	-	-	-	556	574	747	780	801	819
<b>Maximum start-up current (2)</b>												
Circuit A	A	414	414	587	587	587	414	414	587	587	587	587
Circuit B	A	-	-	-	-	-	414	414	414	587	587	587
Option 81	A	-	-	-	-	-	631	656	829	882	904	938
<b>Cosine phi</b>												
Nominal (3)		0,88	0,89	0,88	0,89	0,90	0,86	0,87	0,88	0,88	0,89	0,90
Maximum (4)		0,90	0,90	0,90	0,91	0,92	0,89	0,90	0,90	0,90	0,91	0,92
Total harmonic distortion (4)	%	0	0	0	0	0	0	0	0	0	0	0
<b>Maximum power input†</b>												
Circuit A	kW	135	151	184	200	223	134	151	184	184	200	223
Circuit B	kW	-	-	-	-	-	134	151	151	184	200	223
Option 81	kW	-	-	-	-	-	267	301	334	367	399	447
<b>Nominal current drawn (3)</b>												
Circuit A	A	144	162	193	214	232	144	162	193	193	214	232
Circuit B	A	-	-	-	-	-	144	162	162	193	214	232
Option 81	A	-	-	-	-	-	288	324	355	386	427	464
<b>Maximum current drawn (Un)†</b>												
Circuit A	A	217	242	295	317	351	217	242	295	295	317	351
Circuit B	A	-	-	-	-	-	217	242	242	295	317	351
Option 81	A	-	-	-	-	-	434	484	537	590	634	702
<b>Maximum current drawn (Un -10%) (4)</b>												
Circuit A	A	230	260	304	340	358	230	260	304	304	340	358
Circuit B	A	-	-	-	-	-	230	260	260	304	340	358
Option 81	A	-	-	-	-	-	460	520	564	608	680	716
<b>Maximum power input with option 150B†</b>												
Circuit A	kW	118	133	173	183	207	118	133	173	173	183	207
Circuit B	kW	-	-	-	-	-	118	133	133	173	183	207
Option 81	kW	-	-	-	-	-	235	265	305	346	365	414
<b>Maximum current drawn (Un) with option 150B†</b>												
Circuit A	A	191	212	278	290	325	191	212	278	278	290	325
Circuit B	A	-	-	-	-	-	191	212	212	278	290	325
Option 81	A	-	-	-	-	-	382	424	490	556	580	650

(1) Instantaneous start-up current (maximum operating current of the smallest compressor(s) + locked rotor current or reduced start-up current of the largest compressor). Values obtained at standard Eurovent unit operating conditions: evaporator entering/leaving water temperature = 12°C/7°C, condenser entering/leaving water temperature = 30°C/35°C.

(2) Instantaneous start-up current (maximum operating current of the smallest compressor(s) + locked rotor current or reduced start-up current of the largest compressor). Values obtained at operation with maximum unit power input.

(3) Values obtained at standard Eurovent unit operating conditions: evaporator entering/leaving water temperature = 12°C/7°C, condenser entering/leaving water temperature = 30°C/35°C.

(4) Values obtained at operation with maximum unit power input.

† Values obtained at operation with maximum unit power input. Values given on the unit name plate.

# PHYSICAL DATA, UNITS FOR HIGH CONDENSING TEMPERATURES

## Standard-efficiency units (option 150)

30XW--/30XWH-				254	304	354	402	452	552	602	652	702	802	
<b>Heating</b>														
<b>Unit + option 150</b> Full load performances*	HW1	Nominal capacity	kW	328	366	413	502	536	597	618	756	845	869	
		COP	kW/kW	5,49	5,48	5,44	5,11	5,41	5,27	5,41	5,31	5,37	5,17	
	HW2	Nominal heating capacity	kW	319	356	402	470	501	559	599	706	789	812	
		COP	kW/kW	4,54	4,51	4,47	4,21	4,45	4,36	4,48	4,39	4,44	4,31	
	HW3	Nominal capacity	kW	310	347	391	440	469	523	582	659	738	760	
		COP	kW/kW	3,80	3,78	3,75	3,47	3,67	3,61	3,76	3,62	3,68	3,57	
	Seasonal energy efficiency**	HW1	SCOP <sub>30/35°C</sub>	kWh/kWh	5,77	5,94	5,86	5,54	5,77	5,75	5,72	5,55	5,79	5,01
			η <sub>s heat</sub> <sub>30/35°C</sub>	%	223	230	226	214	223	222	221	214	223	193
		HW3	SCOP <sub>47/55°C</sub>	kWh/kWh	4,58	4,63	4,56	4,20	4,42	4,45	4,50	4,26	4,45	3,86
			η <sub>s heat</sub> <sub>47/55°C</sub>	%	175	177	175	160	169	170	172	163	170	146
		P <sub>rated</sub>		kW	411	415	467	535	571	637	697	803	898	926
		<b>Cooling</b>												
<b>Unit + option 150</b> Full load performances*	CW1	Nominal cooling capacity	kW	278	309	348	NA	NA	NA	NA	NA	NA	NA	
		EER	kW/kW	4,83	4,80	4,76	NA	NA	NA	NA	NA	NA	NA	
Seasonal energy efficiency**	<b>SEER<sub>12/7°C</sub> Comfort low temp.</b>		<b>kWh/kWh</b>	<b>6,19</b>	<b>6,29</b>	<b>6,22</b>	NA	NA	NA	NA	NA	NA	NA	
	η <sub>s cool</sub> <sub>12/7°C</sub>		%	<b>245</b>	<b>249</b>	<b>246</b>	NA	NA	NA	NA	NA	NA	NA	
	SEPR <sub>12/7°C</sub> Process high temp.		kWh/kWh	6,67	6,72	6,57	NA	NA	NA	NA	NA	NA	NA	
Integrated Part Load Value		IPLV.SI	kW/kW	6,364	6,527	6,531	5,928	6,176	6,287	6,185	5,931	6,433	5,575	
<b>Sound levels - unit with option 150</b>														
Sound power level <sup>(1)</sup>		dB(A)	95	95	95	99	99	99	99	99	102	102	102	
Sound pressure level at 1 m <sup>(2)</sup>		dB(A)	78	78	78	82	82	82	82	82	84	84	84	
<b>Sound levels - unit with option 150 + option 257<sup>(3)</sup></b>														
Sound power level <sup>(1)</sup>		dB(A)	-	-	-	96	96	96	96	96	100	100	100	
Sound pressure level at 1 m <sup>(2)</sup>		dB(A)	-	-	-	78	78	78	78	82	82	82	82	
<b>Dimensions - unit with option 150</b>														
Length		mm	2724	2724	2724	2741	2741	2741	2741	2741	3059	3059	3059	
Width		mm	928	928	928	936	936	936	936	936	1090	1090	1090	
Height		mm	1567	1567	1567	1692	1692	1692	1692	1692	1858	1858	1858	
<b>Operating weight<sup>(4)</sup></b>		kg	2017	2036	2072	2575	2575	2613	2644	3407	3438	3462		
<b>Compressors</b>														
				Semi-hermetic 06T screw compressors, 50 r/s										
Circuit A		-	1	1	1	1	1	1	1	1	1	1	1	
Circuit B		-	-	-	-	-	-	-	-	-	-	-	-	

\* In accordance with standard EN14511-3:2022.  
 \*\* In accordance with standard EN14825:2022, average climate  
 HW1 Heating mode conditions: Evaporator entering/leaving water temperature 10°C/7°C, condenser entering/leaving water temperature 30°C/35°C, evaporator and condenser fouling factor 0 m<sup>2</sup>. k/W  
 HW2 Heating mode conditions: Evaporator entering/leaving water temperature 10°C/7°C, condenser entering/leaving water temperature 40°C/45°C, evaporator and condenser fouling factor 0 m<sup>2</sup>. k/W  
 HW3 Heating mode conditions: Evaporator entering/leaving water temperature 10°C/7°C, condenser entering/leaving water temperature 47°C/55°C, evaporator and condenser fouling factor 0 m<sup>2</sup>. k/W  
 CW1 Cooling mode conditions: Evaporator water entering/leaving temperature 12°C/7°C, condenser entering/leaving water temperature 30°C/35°C, evaporator and condenser fouling factor 0 m<sup>2</sup>. K/W  
 η<sub>s heat</sub> <sub>30/35°C</sub> & SCOP<sub>30/35°C</sub> Values calculated in accordance with EN14825:2022  
 η<sub>s heat</sub> <sub>47/55°C</sub> & SCOP<sub>47/55°C</sub> Values calculated in accordance with EN14825:2022  
 η<sub>s cool</sub> <sub>12/7°C</sub> & SEER<sub>12/7°C</sub> **Bold values compliant to Ecodesign regulation: (EU) No 2016/2281 for Comfort application**  
 SEPR<sub>12/7°C</sub> Values calculated in accordance with EN14825:2022  
 IPLV.SI Calculations according to standard performances AHRI 551-591 (SI).  
 NA Non Authorized for the specific application for CEE market  
 (1) In dB ref=10<sup>-12</sup> W, (A) weighting. Declared dualnumber noise emission values in accordance with ISO 4871 (with an associated uncertainty of +/-3dB(A)). Measured in accordance with ISO 9614-1 and certified by Eurovent.  
 (2) In dB ref 20μPa, (A) weighting. Declared dualnumber noise emission values in accordance with ISO 4871 (with an associated uncertainty of +/-3dB(A)). For information, calculated from the sound power level Lw(A).  
 (3) Option 257 = Low noise level  
 (4) Weight shown is guideline only. Please refer to the unit nameplate



Eurovent certified values



AHRI certified values  
30XW-only

## PHYSICAL DATA, UNITS FOR HIGH CONDENSING TEMPERATURES

### Standard-efficiency units (option 150)

30XW--/30XWH-		254	304	354	402	452	552	602	652	702	802
<b>Refrigerant (4)</b>		R-134a									
Circuit A	kg	84	80	78	92	92	92	92	145	135	125
	teqCO <sub>2</sub>	120	114	112	132	132	132	132	207	193	179
Circuit B	kg	-	-	-	-	-	-	-	-	-	-
	teqCO <sub>2</sub>	-	-	-	-	-	-	-	-	-	-
<b>Oil - unit with option 150</b>											
Circuit A	l	23,5	23,5	23,5	32	32	32	32	36	36	36
Circuit B	l	-	-	-	-	-	-	-	-	-	-
<b>Capacity control</b>		SmartVu™, electronic expansion valves (EXV)									
Minimum capacity (5)	%	30	30	30	30	30	30	30	25	25	25
<b>Evaporator</b>		Multi-pipe flooded type									
Water volume	l	50	56	61	70	70	70	70	109	109	109
Water connections (Victaulic)	in	5	5	5	5	5	5	5	6	6	6
Drain and vent connections (NPT)	in	3/8	3/8	3/8	3/8	3/8	3/8	3/8	3/8	3/8	3/8
Max. water-side operating pressure	kPa	1000	1000	1000	1000	1000	1000	1000	1000	1000	1000
<b>Condenser</b>		Multi-pipe flooded type									
Water volume	l	55	55	55	76	76	76	76	109	109	109
Water connections (Victaulic)	in	5	5	5	5	5	5	5	6	6	6
Drain and vent connections (NPT)	in	3/8	3/8	3/8	3/8	3/8	3/8	3/8	3/8	3/8	3/8
Max. water-side operating pressure	kPa	1000	1000	1000	1000	1000	1000	1000	1000	1000	1000

(4) Weight shown is guideline only. Please refer to the unit nameplate

(5) Minimum unit capacity corresponds to a physical state of the unit and is given for indication only. The actual capacity at this stage depends on operating conditions.

# PHYSICAL DATA, UNITS FOR HIGH CONDENSING TEMPERATURES

## Standard-efficiency units (option 150)

30XW--/30XWH-	852	1002	1052	1154	1252	1352	1452	1552	1652	1702
---------------	-----	------	------	------	------	------	------	------	------	------

### Heating

Unit + option 150 Full load performances*	HW1	Nominal capacity	kW	963	1163	1228	1338	1432	1551	1671	1776	1928	1991
		COP	kW/kW	5,36	5,37	5,28	5,38	5,56	5,32	5,23	5,12	5,34	5,27
HW2	Nominal heating capacity	kW	939	1085	1146	1290	1329	1445	1558	1649	1873	1936	
	COP	kW/kW	4,46	4,46	4,40	4,48	4,63	4,45	4,38	4,34	4,50	4,46	
HW3	Nominal capacity	kW	915	1012	1068	1249	1244	1345	1452	1543	1821	1882	
	COP	kW/kW	3,73	3,71	3,66	3,77	3,83	3,68	3,64	3,63	3,81	3,77	
Seasonal energy efficiency**	HW1	SCOP <sub>30/35°C</sub>	kWh/kWh	5,66	5,86	5,86	5,78	6,09	5,69	5,79	5,43	5,93	5,92
		ηs heat <sub>30/35°C</sub>	%	218	226	226	223	236	220	224	209	229	229
	HW3	SCOP <sub>47/55°C</sub>	kWh/kWh	4,47	4,73	4,73	4,61	4,68	4,38	4,45	4,35	4,74	4,76
		ηs heat <sub>47/55°C</sub>	%	171	181	181	176	179	167	170	166	182	182
	P <sub>rated</sub>		kW	1094	1234	1303	1497	1518	1641	1770	1882	2179	2253

### Cooling

Unit + option 150 Full load performances*	CW1	Nominal cooling capacity	kW	NA	NA	NA	NA	NA	NA	NA	NA	NA	NA
		EER	kW/kW	NA	NA	NA	NA	NA	NA	NA	NA	NA	NA
Seasonal energy efficiency**	<b>SEER<sub>12/7°C</sub> Comfort low temp.</b>		<b>kWh/kWh</b>	NA	NA	NA	NA	NA	NA	NA	NA	NA	NA
	ηs cool <sub>12/7°C</sub>		%	NA	NA	NA	NA	NA	NA	NA	NA	NA	NA
	SEPR <sub>12/7°C</sub> Process high temp.		kWh/kWh	NA	NA	NA	NA	NA	NA	NA	NA	NA	NA
Integrated Part Load Value	IPLV.SI	kW/kW	6,351	6,572	6,595	6,522	6,873	6,211	6,615	6,366	6,939	7,136	

### Sound levels - unit with option 150

Sound power level <sup>(1)</sup>	dB(A)	102	102	102	102	105	105	105	105	105	105
Sound pressure level at 1 m <sup>(2)</sup>	dB(A)	84	84	84	84	86	86	86	86	86	86

### Sound levels - unit with option 150 + option 257<sup>(3)</sup>

Sound power level <sup>(1)</sup>	dB(A)	100	99	99	99	103	103	103	103	103	103
Sound pressure level at 1 m <sup>(2)</sup>	dB(A)	82	80	80	80	84	84	84	84	84	84

### Dimensions - unit with option 150

Length	mm	2780	4025	4025	4025	4730	4730	4730	4730	4790	4790
Width	mm	1090	1036	1036	1036	1201	1201	1201	1201	1947	1947
Height	mm	1920	1870	1870	1925	2071	2071	2071	2071	1535	1535

### Operating weight<sup>(4)</sup>

Compressors		Semi-hermetic 06T screw compressors, 50 r/s										
Circuit A	-	1	1	1	1	1	1	1	1	1	1	1
Circuit B	-	-	1	1	1	1	1	1	1	1	1	1

\* In accordance with standard EN14511-3:2022.  
 \*\* In accordance with standard EN14825:2022, average climate  
 HW1 Heating mode conditions: Evaporator entering/leaving water temperature 10°C/7°C, condenser entering/leaving water temperature 30°C/35°C, evaporator and condenser fouling factor 0 m<sup>2</sup>. k/W  
 HW2 Heating mode conditions: Evaporator entering/leaving water temperature 10°C/7°C, condenser entering/leaving water temperature 40°C/45°C, evaporator and condenser fouling factor 0 m<sup>2</sup>. k/W  
 HW3 Heating mode conditions: Evaporator entering/leaving water temperature 10°C/7°C, condenser entering/leaving water temperature 47°C/55°C, evaporator and condenser fouling factor 0 m<sup>2</sup>. k/W  
 CW1 Cooling mode conditions: Evaporator water entering/leaving temperature 12°C/7°C, condenser entering/leaving water temperature 30°C/35°C, evaporator and condenser fouling factor 0 m<sup>2</sup>. K/W  
 ηs heat<sub>30/35°C</sub> & SCOP<sub>30/35°C</sub> Values calculated in accordance with EN14825:2022  
 ηs heat<sub>47/55°C</sub> & SCOP<sub>47/55°C</sub> Values calculated in accordance with EN14825:2022  
 ηs cool<sub>12/7°C</sub> & SEER<sub>12/7°C</sub> **Bold values compliant to Ecodesign regulation: (EU) No 2016/2281 for Comfort application**  
 SEPR<sub>12/7°C</sub> Values calculated in accordance with EN14825:2022  
 IPLV.SI Calculations according to standard performances AHRI 551-591 (SI).  
 (1) In dB ref=10<sup>-12</sup> W, (A) weighting. Declared dualnumber noise emission values in accordance with ISO 4871 (with an associated uncertainty of +/-3dB(A)). Measured in accordance with ISO 9614-1 and certified by Eurovent.  
 (2) In dB ref 20μPa, (A) weighting. Declared dualnumber noise emission values in accordance with ISO 4871 (with an associated uncertainty of +/-3dB(A)). For information, calculated from the sound power level Lw(A).  
 (3) Option 257 = Low noise level  
 (4) Weight shown is guideline only. Please refer to the unit nameplate



Eurovent certified values



AHRI certified values 30XW-only

## PHYSICAL DATA, UNITS FOR HIGH CONDENSING TEMPERATURES

### Standard-efficiency units (option 150)

30XW--/30XWH-		852	1002	1052	1154	1252	1352	1452	1552	1652	1702
<b>Refrigerant (4)</b>		R-134a									
Circuit A	kg	158	85	85	105	120	115	110	105	195	195
	teqCO <sub>2</sub>	226	122	122	150	172	164	157	150	279	279
Circuit B	kg	-	85	85	105	120	115	110	105	195	195
	teqCO <sub>2</sub>	-	122	122	150	172	164	157	150	279	279
<b>Oil - unit with option 150</b>											
Circuit A	l	36	32	32	32	36	36	36	36	36	36
Circuit B	l	-	32	32	32	32	36	36	36	36	36
<b>Capacity control</b>		SmartVu™, electronic expansion valves (EXV)									
Minimum capacity (5)	%	25	15	15	15	15	10	10	10	10	10
<b>Evaporator</b>		Multi-pipe flooded type									
Water volume	l	98	182	182	205	301	301	301	301	354	354
Water connections (Victaulic)	in	6	6	6	8	8	8	8	8	8	8
Drain and vent connections (NPT)	in	3/8	3/8	3/8	3/8	3/8	3/8	3/8	3/8	3/8	3/8
Max. water-side operating pressure	kPa	1000	1000	1000	1000	1000	1000	1000	1000	1000	1000
<b>Condenser</b>		Multi-pipe flooded type									
Water volume	l	137	193	193	193	340	340	340	340	426	426
Water connections (Victaulic)	in	8	8	8	8	8	8	8	8	8	8
Drain and vent connections (NPT)	in	3/8	3/8	3/8	3/8	3/8	3/8	3/8	3/8	3/8	3/8
Max. water-side operating pressure	kPa	1000	1000	1000	1000	1000	1000	1000	1000	1000	1000

(4) Weight shown is guideline only. Please refer to the unit nameplate

(5) Minimum unit capacity corresponds to a physical state of the unit and is given for indication only. The actual capacity at this stage depends on operating conditions.



# PHYSICAL DATA, UNITS FOR HIGH CONDENSING TEMPERATURES

## Standard-efficiency units (option 150)

30XW-P / 30XWHP	512	562	712	812	862	1012	1162	1314	1464	1612	1762
-----------------	-----	-----	-----	-----	-----	------	------	------	------	------	------

### Heating

Unit + option 150														
Full load performances*	HW1	Nominal capacity	kW	600	670	840	910	975	1188	1375	1514	1698	1890	1983
		COP	kW/kW	5,89	5,90	5,72	5,58	5,72	5,61	5,77	5,55	5,40	5,78	5,73
	HW2	Nominal heating capacity	kW	580	646	815	885	950	1147	1322	1465	1648	1834	1929
		COP	kW/kW	4,85	4,86	4,72	4,61	4,75	4,65	4,80	4,62	4,52	4,80	4,79
	HW3	Nominal capacity	kW	561	625	790	862	925	1110	1275	1419	1598	1783	1874
		COP	kW/kW	4,02	4,04	3,92	3,83	3,97	3,86	4,01	3,88	3,81	4,00	4,00
Seasonal energy efficiency**	HW1	SCOP <sub>30/35°C</sub>	kWh/kWh	6,15	6,22	6,40	6,11	5,99	5,97	6,24	6,18	6,18	6,50	6,21
		ηs heat <sub>30/35°C</sub>	%	238	241	248	236	231	231	242	239	239	252	240
		SCOP <sub>47/55°C</sub>	kWh/kWh	4,78	4,86	4,97	4,76	4,73	4,63	4,88	4,88	4,94	5,07	4,92
	HW3	ηs heat <sub>47/55°C</sub>	%	183	186	191	182	181	177	187	187	189	195	189
		P <sub>rated</sub>	kW	673	749	947	1030	1106	1330	1531	1701	1915	2133	2243

### Cooling

Unit + option 150														
Full load performances*	CW1	Nominal cooling capacity	kW	510	569	715	770	833	1011	1178	1287	1437	1613	1706
		EER	kW/kW	5,14	5,17	5,02	4,88	5,09	4,98	5,23	4,96	4,84	5,15	5,21
Seasonal energy efficiency**		SEER <sub>12/7°C</sub> Comfort low temp.	kWh/kWh	<b>6,53</b>	<b>6,68</b>	<b>6,81</b>	<b>6,56</b>	<b>6,45</b>	<b>6,51</b>	<b>6,95</b>	<b>6,76</b>	<b>6,66</b>	<b>7,13</b>	<b>6,90</b>
		ηs cool <sub>12/7°C</sub>	%	<b>258</b>	<b>264</b>	<b>269</b>	<b>259</b>	<b>255</b>	<b>258</b>	<b>275</b>	<b>267</b>	<b>264</b>	<b>282</b>	<b>273</b>
		SEPR <sub>12/7°C</sub> Process high temp.	kWh/kWh	6,90	6,93	7,23	6,68	6,38	6,71	6,97	6,88	7,03	7,15	6,63
Integrated Part Load Value	IPLV.SI	kW/kW	6,612	6,804	7,029	6,703	6,782	6,505	6,997	6,946	7,131	7,302	7,308	

### Sound levels - unit with option 150

Sound power level <sup>(1)</sup>	dB(A)	99	99	102	102	102	102	102	102	105	105	105	105
Sound pressure level at 1 m <sup>(2)</sup>	dB(A)	82	82	84	84	84	83	83	83	86	86	86	86

### Sound levels - unit with option 150 + option 257<sup>(3)</sup>

Sound power level <sup>(1)</sup>	dB(A)	96	96	100	100	100	99	99	99	103	103	103	103
Sound pressure level at 1 m <sup>(2)</sup>	dB(A)	78	78	82	82	82	80	80	80	84	84	84	84

### Dimensions - unit with option 150

Length	mm	3059	3059	3290	3290	3290	4730	4730	4730	4730	4832	4832
Width	mm	936	936	1105	1105	1105	1039	1039	1202	1202	2174	2174
Height	mm	1743	1743	1970	1970	1970	1997	1997	2071	2071	1585	1585
Operating weight <sup>(4)</sup>	kg	2981	3020	4072	4117	4145	6872	6950	7721	8059	11225	11279

### Compressors

		Semi-hermetic 06T screw compressors, 50 r/s											
Circuit A	-	1	1	1	1	1	1	1	1	1	1	1	1
Circuit B	-	-	-	-	-	-	1	1	1	1	1	1	1

\* In accordance with standard EN14511-3:2022.  
 \*\* In accordance with standard EN14825:2022, average climate  
 HW1 Heating mode conditions: Evaporator entering/leaving water temperature 10°C/7°C, condenser entering/leaving water temperature 30°C/35°C, evaporator and condenser fouling factor 0 m<sup>2</sup>. kW  
 HW2 Heating mode conditions: Evaporator entering/leaving water temperature 10°C/7°C, condenser entering/leaving water temperature 40°C/45°C, evaporator and condenser fouling factor 0 m<sup>2</sup>. kW  
 HW3 Heating mode conditions: Evaporator entering/leaving water temperature 10°C/7°C, condenser entering/leaving water temperature 47°C/55°C, evaporator and condenser fouling factor 0 m<sup>2</sup>. kW  
 CW1 Cooling mode conditions: Evaporator water entering/leaving temperature 12°C/7°C, condenser entering/leaving water temperature 30°C/35°C, evaporator and condenser fouling factor 0 m<sup>2</sup>. kW  
 ηs heat<sub>30/35°C</sub> & SCOP<sub>30/35°C</sub> Values calculated in accordance with EN14825:2022  
 ηs heat<sub>47/55°C</sub> & SCOP<sub>47/55°C</sub> Values calculated in accordance with EN14825:2022  
 ηs cool<sub>12/7°C</sub> & SEER<sub>12/7°C</sub> **Bold values compliant to Ecodesign regulation: (EU) No 2016/2281 for Comfort application**  
 SEPR<sub>12/7°C</sub> Values calculated in accordance with EN14825:2022  
 IPLV.SI Calculations according to standard performances AHRI 551-591 (SI).  
 (1) In dB ref=10<sup>-12</sup> W, (A) weighting. Declared dualnumber noise emission values in accordance with ISO 4871 (with an associated uncertainty of +/-3dB(A)). Measured in accordance with ISO 9614-1 and certified by Eurovent.  
 (2) In dB ref 20μPa, (A) weighting. Declared dualnumber noise emission values in accordance with ISO 4871 (with an associated uncertainty of +/-3dB(A)). For information, calculated from the sound power level Lw(A).  
 (3) Option 257 = Low noise level  
 (4) Weight shown is guideline only. Please refer to the unit nameplate



Eurovent certified values



AHRI certified values  
30XW-only

## PHYSICAL DATA, UNITS FOR HIGH CONDENSING TEMPERATURES

### Standard-efficiency units (option 150)

30XW-P / 30XWHP		512	562	712	812	862	1012	1162	1314	1464	1612	1762
<b>Refrigerant (4)</b>		R-134a										
Circuit A	kg	130	130	180	175	177	120	120	130	130	240	250
	teqCO <sub>2</sub>	186	186	257	250	253	172	172	186	186	343	358
Circuit B	kg	-	-	-	-	-	120	120	150	130	240	250
	teqCO <sub>2</sub>	-	-	-	-	-	172	172	215	186	343	358
<b>Oil - unit with option 150</b>												
Circuit A	l	32	32	36	36	36	32	32	36	36	36	36
Circuit B	l	-	-	-	-	-	32	32	32	36	36	36
<b>Capacity control</b>		SmartVu™, electronic expansion valves (EXV)										
Minimum capacity (5)	%	30	30	20	20	20	15	15	15	10	10	10
<b>Evaporator</b>		Multi-pipe flooded type										
Water volume	l	101	101	154	154	154	293	293	321	321	473	473
Water connections (Victaulic)	in	6	6	8	8	8	8	8	8	8	10	10
Drain and vent connections (NPT)	in	3/8	3/8	3/8	3/8	3/8	3/8	3/8	3/8	3/8	3/8	3/8
Max. water-side operating pressure	kPa	1000	1000	1000	1000	1000	1000	1000	1000	1000	1000	1000
<b>Condenser</b>		Multi-pipe flooded type										
Water volume	l	103	103	148	148	148	316	316	340	340	623	623
Water connections (Victaulic)	in	6	6	8	8	8	8	8	10	10	10	10
Drain and vent connections (NPT)	in	3/8	3/8	3/8	3/8	3/8	3/8	3/8	3/8	3/8	3/8	3/8
Max. water-side operating pressure	kPa	1000	1000	1000	1000	1000	1000	1000	1000	1000	1000	1000

(4) Weight shown is guideline only. Please refer to the unit nameplate

(5) Minimum unit capacity corresponds to a physical state of the unit and is given for indication only. The actual capacity at this stage depends on operating conditions.

### Standard-efficiency 30XW/30XWH units (options 6)

30XW--/30XWH (reference)		254	304	354	402	452	552	602	702	802
<b>Operating weight</b>	kg	2041	2063	2102	2609	2609	2647	2678	3492	3516
<b>Refrigerant charge(1)</b>		R-134a								
Circuit A	kg	91	86	84	99	99	99	99	146	135
	teqCO <sub>2</sub>	129730	123552	120463	142085	142085	142085	142085	208494	193050
Circuit B	kg	0	0	0	0	0	0	0	0	0
	teqCO <sub>2</sub>	0	0	0	0	0	0	0	0	0
<b>Evaporator</b>		Single pass, multi-pipe flooded type								
Water volume	l	50	56	61	70	70	70	70	109	109
Water connections (Victaulic)	in	5	5	5	6	6	6	6	6	6
Drain and vent connections (NPT)	in	3/8	3/8	3/8	3/8	3/8	3/8	3/8	3/8	3/8
Max. water-side operating pressure	kPa	1000	1000	1000	1000	1000	1000	1000	1000	1000
30XW--/30XWH (reference)		852	1002	1052	1154	1252	1452	1552	1652	1702
<b>Operating weight</b>	kg	3720	5467	5505	5806	7392	7781	7829	9193	9219
<b>Refrigerant charge(1)</b>		R-134a								
Circuit A	kg	171	92	92	113	130	119	113	211	211
	teqCO <sub>2</sub>	244015	131274	131274	162162	185328	169884	162162	301158	301158
Circuit B	kg	0	92	92	113	130	119	113	211	211
	teqCO <sub>2</sub>	0	131274	131274	162162	185328	169884	162162	301158	301730
<b>Evaporator</b>		Single pass, multi-pipe flooded type								
Water volume	l	98	182	182	205	301	301	301	354	354
Water connections (Victaulic)	in	6	6	6	8	8	8	8	8	8
Drain and vent connections (NPT)	in	3/8	3/8	3/8	3/8	3/8	3/8	3/8	3/8	3/8
Max. water-side operating pressure	kPa	1000	1000	1000	1000	1000	1000	1000	1000	1000

(1) Weights are guidelines only. The refrigerant charge is given on the unit nameplate.

## ELECTRICAL DATA, UNITS FOR HIGH CONDENSING TEMPERATURES

### Standard-efficiency units (option 150)

30XW--/30XWH-		254	304	354	402	452	552	602	652	702	802
<b>Power circuit</b>											
Nominal power supply	V-ph-Hz	400-3-50									
Voltage range	V	360-440									
<b>Control circuit</b>											
24 V via the built-in transformer											
<b>Nominal start-up current (1)</b>											
Circuit A	A	303	388	388	587	587	587	587	772	772	772
Circuit B	A	-	-	-	-	-	-	-	-	-	-
Option 81	A	-	-	-	-	-	-	-	-	-	-
<b>Maximum start-up current (2)</b>											
Circuit A	A	303	388	388	587	587	587	587	772	772	772
Circuit B	A	-	-	-	-	-	-	-	-	-	-
Option 81	A	-	-	-	-	-	-	-	-	-	-
<b>Cosine phi</b>											
Nominal (3)		0,79	0,78	0,79	0,83	0,85	0,85	0,85	0,84	0,86	0,87
Maximum (4)		0,88	0,87	0,88	0,90	0,90	0,91	0,91	0,90	0,90	0,90
Total harmonic distortion (4)	%	0	0	0	0	0	0	0	0	0	0
<b>Maximum power input†</b>											
Circuit A	kW	97	111	122	156	173	191	191	249	268	286
Circuit B	kW	-	-	-	-	-	-	-	-	-	-
Option 81	kW	-	-	-	-	-	-	-	-	-	-
<b>Nominal current drawn (3)</b>											
Circuit A	A	95	109	125	150	162	171	171	193	214	232
Circuit B	A	-	-	-	-	-	-	-	-	-	-
Option 81	A	-	-	-	-	-	-	-	-	-	-
<b>Maximum current drawn (Un)†</b>											
Circuit A	A	160	185	200	250	275	300	300	400	430	460
Circuit B	A	-	-	-	-	-	-	-	-	-	-
Option 81	A	-	-	-	-	-	-	-	-	-	-
<b>Maximum current drawn (Un -10%) (4)</b>											
Circuit A	A	176	206	224	270	300	330	330	419	455	476
Circuit B	A	-	-	-	-	-	-	-	-	-	-
Option 81	A	-	-	-	-	-	-	-	-	-	-

(1) Instantaneous start-up current (maximum operating current of the smallest compressor(s) + locked rotor current or reduced start-up current of the largest compressor). Values based on standard Eurovent unit operating conditions: evaporator entering/leaving water temp. = 12°C/7°C, condenser entering/leaving water temp. = 30°C/35°C.

(2) Instantaneous start-up current (maximum operating current of the smallest compressor(s) + locked rotor current or reduced start-up current of the largest compressor). Values obtained at operation with maximum unit power input.

(3) Values based on standard Eurovent unit operating conditions: evaporator entering/leaving water temp. = 12°C/7°C, condenser entering/leaving water temp. = 30°C/35°C.

(4) Values obtained at operation with maximum unit power input.

† Values obtained at operation with maximum unit power input. Values given on the unit name plate.

## ELECTRICAL DATA, UNITS FOR HIGH CONDENSING TEMPERATURES

### Standard-efficiency units (option 150)

30XW--/30XWH-		852	1002	1052	1154	1252	1352	1452	1552	1652	1702
<b>Power circuit</b>											
Nominal power supply	V-ph-Hz	400-3-50									
Voltage range	V	360-440									
<b>Control circuit</b>											
24 V via the built-in transformer											
<b>Nominal start-up current <sup>(1)</sup></b>											
Circuit A	A	772	587	587	587	772	772	772	772	772	772
Circuit B	A	-	587	587	587	587	772	772	772	772	772
Option 81	A	-	757	757	757	943	965	986	1004	1004	1004
<b>Maximum start-up current <sup>(2)</sup></b>											
Circuit A	A	772	587	587	587	772	772	772	772	772	772
Circuit B	A	-	587	587	587	587	772	772	772	772	772
Option 81	A	-	887	887	887	1072	1172	1202	1232	1004	1232
<b>Cosine phi</b>											
Nominal <sup>(3)</sup>		0,87	0,85	0,85	0,85	0,86	0,85	0,86	0,87	0,86	0,87
Maximum <sup>(4)</sup>		0,90	0,90	0,91	0,91	0,91	0,91	0,91	0,91	0,91	0,91
Total harmonic distortion <sup>(4)</sup>	%	0	0	0	0	0	0	0	0	0	0
<b>Maximum power input†</b>											
Circuit A	kW	286	191	191	191	252	252	271	290	290	290
Circuit B	kW	-	173	191	191	191	252	271	290	271	290
Option 81	kW	-	364	382	382	443	504	542	580	562	580
<b>Nominal current drawn <sup>(3)</sup></b>											
Circuit A	A	232	171	171	171	210	210	230	250	250	250
Circuit B	A	-	162	171	171	171	210	230	250	230	250
Option 81	A	-	333	342	342	381	420	460	500	480	500
<b>Maximum current drawn (Un)†</b>											
Circuit A	A	460	300	300	300	400	400	430	460	460	460
Circuit B	A	-	275	300	300	300	400	430	460	430	460
Option 81	A	-	575	600	600	700	800	860	920	890	920
<b>Maximum current drawn (Un -10%) <sup>(4)</sup></b>											
Circuit A	A	476	330	330	330	419	419	455	476	476	476
Circuit B	A	-	300	330	330	330	419	455	476	455	476
Option 81	A	-	630	660	660	749	838	910	952	931	952

(1) Instantaneous start-up current (maximum operating current of the smallest compressor(s) + locked rotor current or reduced start-up current of the largest compressor). Values based on standard Eurovent unit operating conditions: evaporator entering/leaving water temp. = 12°C/7°C, condenser entering/leaving water temp. = 30°C/35°C.

(2) Instantaneous start-up current (maximum operating current of the smallest compressor(s) + locked rotor current or reduced start-up current of the largest compressor). Values obtained at operation with maximum unit power input.

(3) Values based on standard Eurovent unit operating conditions: evaporator entering/leaving water temp. = 12°C/7°C, condenser entering/leaving water temp. = 30°C/35°C.

(4) Values obtained at operation with maximum unit power input.

† Values obtained at operation with maximum unit power input. Values given on the unit name plate.

## ELECTRICAL DATA, UNITS FOR HIGH CONDENSING TEMPERATURES

### High-efficiency units (option 150)

30XW-P/30XWHP		512	562	712	812	862	1012	1162	1314	1464	1612	1762
<b>Power circuit</b>												
Nominal power supply	V-ph-Hz	400-3-50										
Voltage range	V	360-440										
<b>Control circuit</b>												
24 V via the built-in transformer												
<b>Nominal start-up current <sup>(1)</sup></b>												
Circuit A	A	587	587	772	772	772	587	587	772	772	772	772
Circuit B	A	-	-	-	-	-	587	587	587	772	772	772
Option 81	A	-	-	-	-	-	749	757	943	965	986	1004
<b>Maximum start-up current <sup>(2)</sup></b>												
Circuit A	A	587	587	772	772	772	587	587	772	772	772	772
Circuit B	A	-	-	-	-	-	587	587	587	772	772	772
Option 81	A	-	-	-	-	-	862	887	1072	1172	1202	1232
<b>Cosine phi</b>												
Nominal <sup>(3)</sup>		0,88	0,88	0,84	0,86	0,87	0,87	0,88	0,86	0,85	0,86	0,87
Maximum <sup>(4)</sup>		0,91	0,92	0,90	0,90	0,90	0,91	0,92	0,91	0,91	0,91	0,91
Total harmonic distortion <sup>(4)</sup>	%	0	0	0	0	0	0	0	0	0	0	0
<b>Maximum power input†</b>												
Circuit A	kW	173	191	252	271	290	173	191	252	252	271	290
Circuit B	kW	-	-	-	-	-	173	191	191	252	271	290
Option 81	kW	-	-	-	-	-	346	382	443	504	542	580
<b>Nominal current drawn <sup>(3)</sup></b>												
Circuit A	A	162	171	210	230	250	162	171	210	210	230	250
Circuit B	A	-	-	-	-	-	162	171	171	210	230	250
Option 81	A	-	-	-	-	-	324	342	381	420	460	500
<b>Maximum current drawn (Un)†</b>												
Circuit A	A	275	300	400	430	460	275	300	400	400	430	460
Circuit B	A	-	-	-	-	-	275	300	300	400	430	460
Option 81	A	-	-	-	-	-	550	600	700	800	860	920
<b>Maximum current drawn (Un -10%) <sup>(4)</sup></b>												
Circuit A	A	300	330	419	455	476	300	330	419	419	455	476
Circuit B	A	-	-	-	-	-	300	330	330	419	455	476
Option 81	A	-	-	-	-	-	600	660	749	838	910	952

(1) Instantaneous start-up current (maximum operating current of the smallest compressor(s) + locked rotor current or reduced start-up current of the largest compressor). Values based on standard Eurovent unit operating conditions: evaporator entering/leaving water temp. = 12°C/7°C, condenser entering/leaving water temp. = 30°C/35°C.

(2) Instantaneous start-up current (maximum operating current of the smallest compressor(s) + locked rotor current or reduced start-up current of the largest compressor). Values obtained at operation with maximum unit power input.

(3) Values based on standard Eurovent unit operating conditions: evaporator entering/leaving water temp. = 12°C/7°C, condenser entering/leaving water temp. = 30°C/35°C.

(4) Values obtained at operation with maximum unit power input.

† Values obtained at operation with maximum unit power input. Values given on the unit name plate.



## DIMENSIONS/CLEARANCES

30XW--/30XWH- 254-852  
30XW-P/30XWHP 512-862

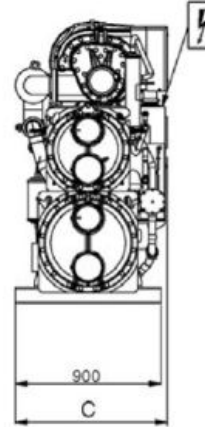
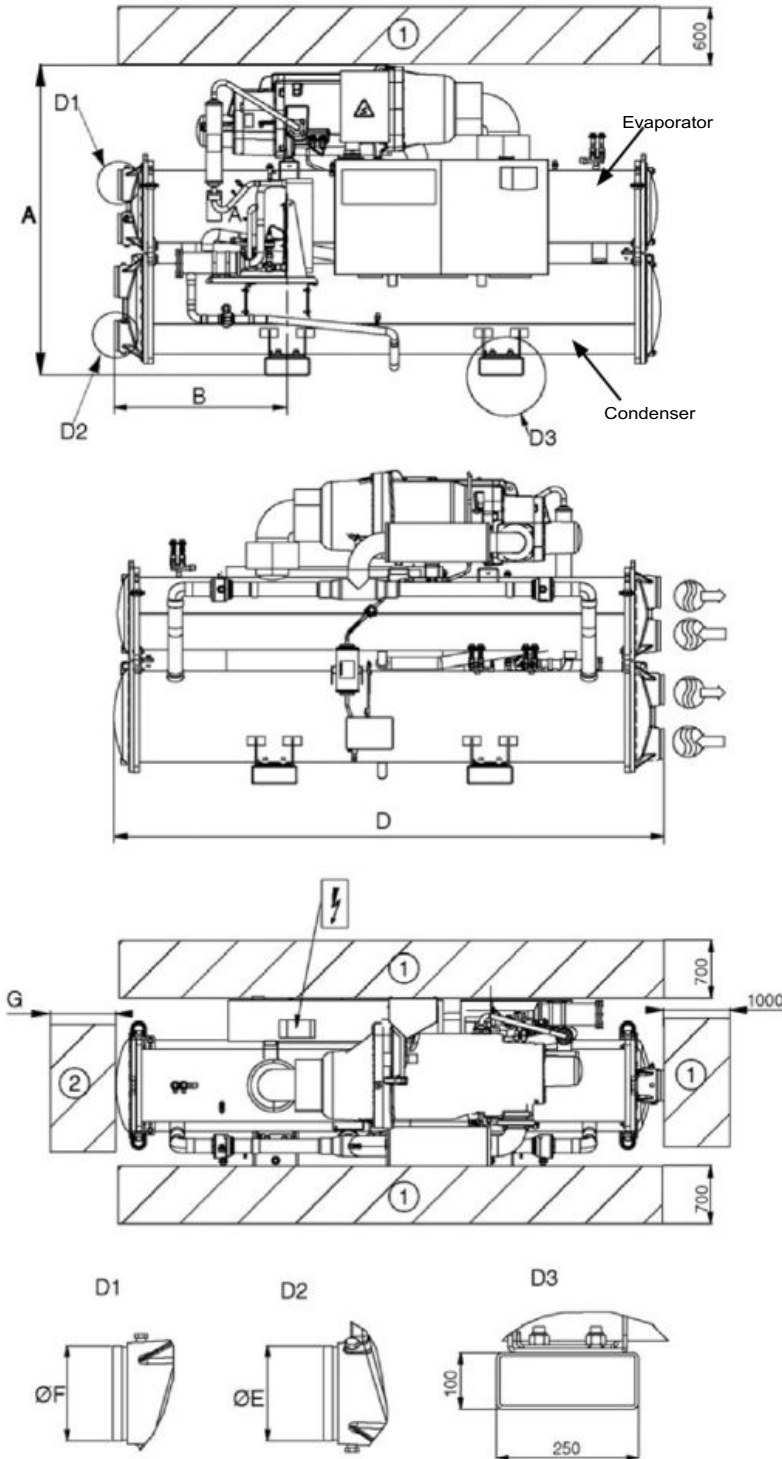

	Dimensions in mm						
	A	B	C	D	E	F	G
<b>Standard-efficiency units 30XW--/30XWH-</b>							
254	1567	800	928	2724	141,3	141,3	2600
304	1567	800	928	2724	141,3	141,3	2600
354	1567	800	928	2724	141,3	141,3	2600
402	1693	810	936	2742	141,3	141,3	2600
452	1693	810	936	2742	141,3	141,3	2600
552	1693	810	936	2742	141,3	141,3	2600
602	1693	810	936	2742	141,3	141,3	2600
652	1848	968	1044	3059	168,3	168,3	2800
702	1848	968	1044	3059	168,3	168,3	2800
802	1848	968	1044	3059	168,3	168,3	2800
852	1898	828	1044	2780	219,1	168,3	2600
<b>High-efficiency units 30XW-P/30XWHP</b>							
512	1743	968	936	3059	168,3	168,3	2800
562	1743	968	936	3059	168,3	168,3	2800
712	1950	1083	1065	3290	219,1	219,1	3100
812	1950	1083	1070	3290	219,1	219,1	3100
862	1950	1083	1070	3290	219,1	219,1	3100
<b>Standard-efficiency units 30XW--/30XWH- (option 150)</b>							
254	1567	800	928	2724	141,3	141,3	2600
304	1567	800	928	2724	141,3	141,3	2600
354	1567	800	928	2724	141,3	141,3	2600
402	1693	810	936	2742	141,3	141,3	2600
452	1693	810	936	2742	141,3	141,3	2600
552	1693	810	936	2742	141,3	141,3	2600
602	1693	810	936	2742	141,3	141,3	2600
652	1868	968	1090	3059	168,3	168,3	2800
702	1868	968	1090	3059	168,3	168,3	2800
802	1868	968	1090	3059	168,3	168,3	2800
852	1920	828	1090	2780	168,3	219,1	2600
<b>High-efficiency units 30XW-P/30XWHP (option 150)</b>							
512	1743	968	936	3059	168,3	168,3	2800
562	1743	968	936	3059	168,3	168,3	2800
712	1970	1083	1105	3290	219,1	219,1	3100
812	1970	1083	1105	3290	219,1	219,1	3100
862	1970	1083	1105	3290	219,1	219,1	3100

**Legend**

All dimensions are given in mm.

- ① Required clearance for maintenance
- ② Recommended clearance for tube removal
- ↙ Water inlet
- ↘ Water outlet
- ))) Air outlet – do not obstruct
- ⚡ Power supply connection

- Option 6 has same dimensions as option 150.
- Option 20 (IP44) has same dimensions as option 150 on units 652, 712, 802, 852, 862. Option 20 has same dimensions as standard on the other units.

**NOTE:** Drawings are not contractually binding. Before designing an installation, consult the certified dimensional drawings, available on request.

## DIMENSIONS/CLEARANCES

30XW-/30XWH- 1002-1552  
 30XW-P/30XWHP 1012-1464

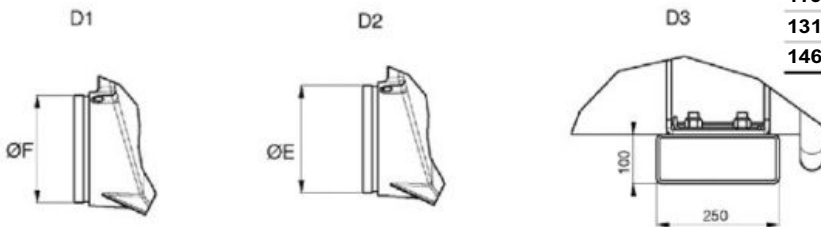
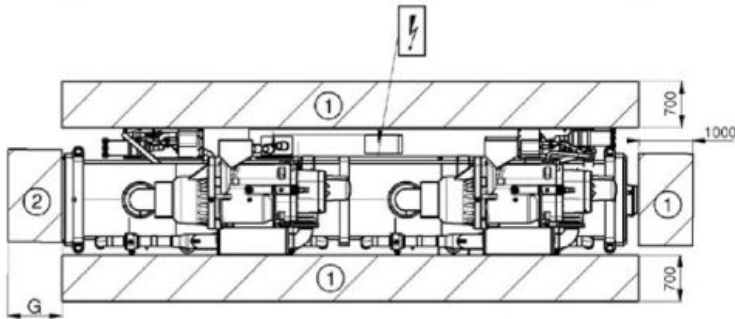
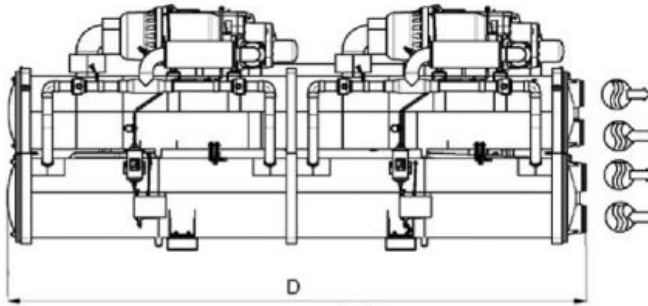
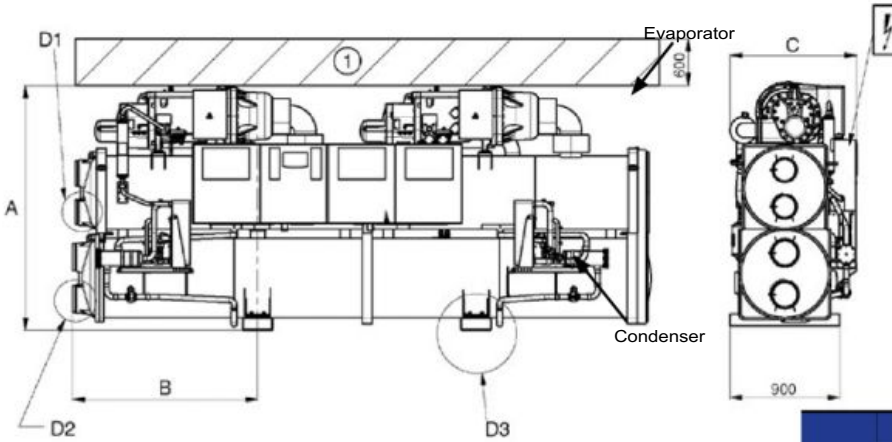

	Dimensions in mm						
	A	B	C	D	E	F	G
<b>Standard-efficiency units 30XW-/30XWH-</b>							
1002	1870	950	1036	4025	219,1	168,3	3800
1052	1870	950	1036	4025	219,1	168,3	3800
1152	1925	950	1036	4025	219,1	219,1	3800
1252	2051	1512	1162	4730	219,1	219,1	4500
1352	2051	1512	1162	4730	219,1	219,1	4500
1452	2051	1512	1162	4730	219,1	219,1	4500
1552	2051	1512	1162	4730	219,1	219,1	4500
<b>High-efficiency units 30XW-P/30XWHP</b>							
1012	1997	1512	1039	4730	219,1	219,1	4500
1162	1997	1512	1039	4730	219,1	219,1	4500
1314	2051	1512	1162	4730	219,1	219,1	4500
1464	2051	1512	1162	4730	219,1	219,1	4500
<b>Standard-efficiency units 30XW-/30XWH- (option 150)</b>							
1002	1870	950	1036	4025	219,1	168,3	3800
1052	1870	950	1036	4025	219,1	168,3	3800
1154	2925	950	1036	4025	219,1	219,1	3800
1252	2071	1512	1202	4730	219,1	219,1	4500
1352	2071	1512	1202	4730	219,1	219,1	4500
1452	2071	1512	1202	4730	219,1	219,1	4500
1552	2071	1512	1202	4730	219,1	219,1	4500
<b>High-efficiency units 30XW-P/30XWHP (option 150)</b>							
1012	1997	1512	1039	4730	219,1	219,1	4500
1162	1997	1512	1039	4730	219,1	219,1	4500
1314	2071	1512	1202	4730	219,1	219,1	4500
1464	2071	1512	1202	4730	219,1	219,1	4500

**Legend**

All dimensions are given in mm.

- ① Required clearance for maintenance
- ② Recommended clearance for tube removal
- Water inlet
- Water outlet
- Air outlet – do not obstruct
- Power supply connection

- Option 6 has same dimensions as option 150.  
 - Option 20 (IP44) has same dimensions as option 150 on units 652, 712, 802, 852, 862. Option 20 has same dimensions as standard on the other units.

**NOTE:** Drawings are not contractually binding. Before designing an installation, consult the certified dimensional drawings, available on request.

## DIMENSIONS/CLEARANCES

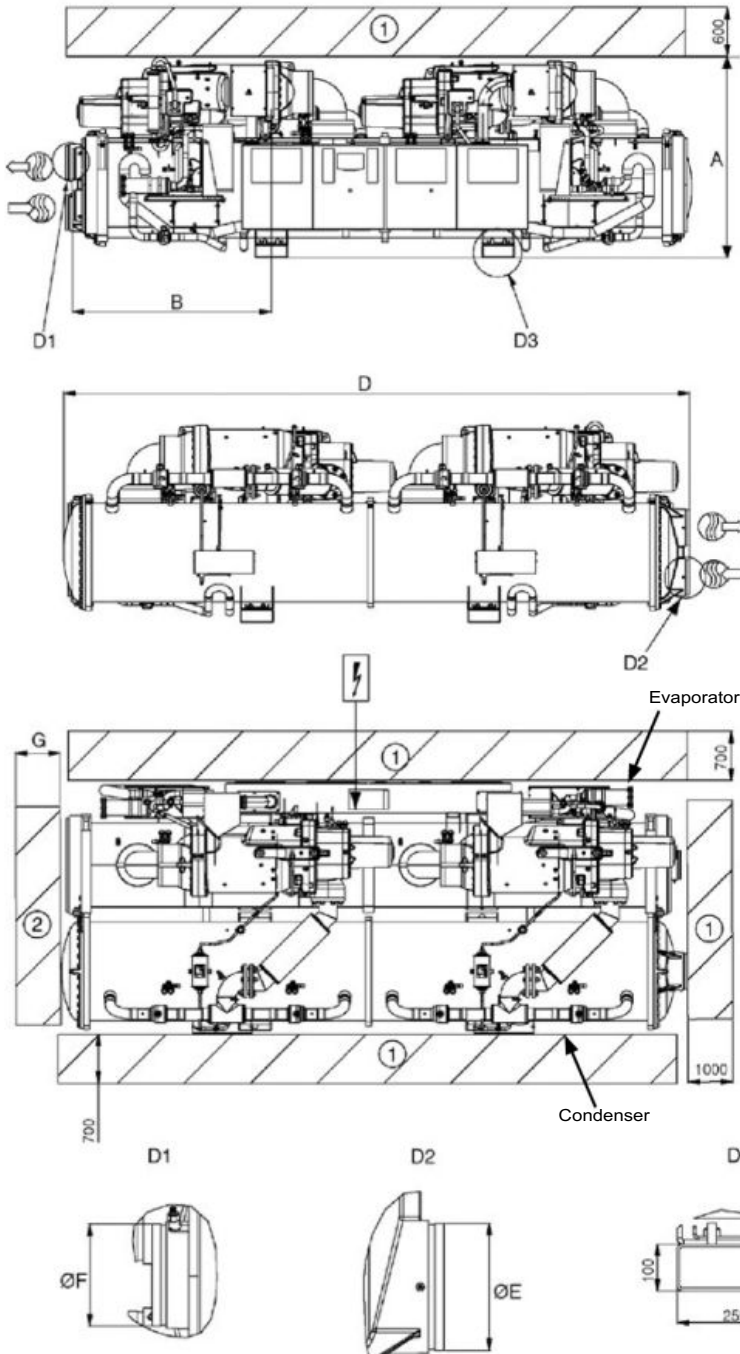
**30XW--/30XWH- 1652-1702**
**30XW-P/30XWHP 1612-1762**

	Dimensions in mm						
	A	B	C	D	E	F	G
<b>Standard-efficiency units 30XW--/30XWH-</b>							
<b>1652</b>	1515	1568	1902	4790	219,1	219,1	4500
<b>1702</b>	1515	1568	1902	4790	219,1	219,1	4500
<b>High-efficiency units 30XW-P/30XWHP</b>							
<b>1612</b>	1562	1591	2129	4832	273,1	273,1	4600
<b>1762</b>	1562	1591	2129	4832	273,1	273,1	4600
<b>Standard-efficiency units 30XW--/30XWH- (option 150)</b>							
<b>1652</b>	1535	1568	1947	4790	219,1	219,1	4500
<b>1702</b>	1535	1568	1947	4790	219,1	219,1	4500
<b>High-efficiency units 30XW-P/30XWHP (option 150)</b>							
<b>1612</b>	1585	1591	2174	4832	273,1	273,1	4600
<b>1762</b>	1585	1591	2174	4832	273,1	273,1	4600

**Legend**

All dimensions are given in mm.

- ① Required clearance for maintenance
- ② Recommended clearance for tube removal
- Water inlet
- Water outlet
- Air outlet – do not obstruct
- Power supply connection

- Option 6 has same dimensions as option 150.
- Option 20 (IP44) has same dimensions as option 150 on units 652, 712, 802, 852, 862. Option 20 has same dimensions as standard on the other units.

**NOTE:** Drawings are not contractually binding. Before designing an installation, consult the certified dimensional drawings, available on request.





## WATER-COOLED VARIABLE-SPEED SCREW CHILLERS



- Low energy consumption
- High reliability
- Easy and fast installation
- Minimised operating sound levels
- Environmental care
- Designed to support green building design

## 30XW-V



Nominal cooling capacity 587-1741 kW

The 30XW-V/30XWHV water-sourced units are the premium solution for commercial and industrial applications where installers, consultants and building owners require maximum quality and optimal performances, especially at part load.

The 30XW-V/30XWHV units are designed to meet current and future requirements in terms of energy efficiency, versatility and compactness. They feature exclusive inverter-driven screw compressors - an evolution of the proven traditional Carrier twin-rotor screw compressor design. Other features include:

- The new SmartVu™ control
- Mechanically cleanable flooded heat exchangers
- Refrigerant R-134a

The 30XW-V/30XWHV range is split into two versions:

- 30XW-V for air conditioning applications
- 30XWHV for heating applications

As standard, the unit can provide an evaporator leaving water temperature down to 3.3°C, and when operating as a heat pump, it can deliver up to 50°C on the condenser side.



CARRIER participates in the ECP programme for LCP-HP  
Check ongoing validity of certificate:  
[www.eurovent-certification.com](http://www.eurovent-certification.com)



## CUSTOMER BENEFITS

### Low energy consumption

- The 30XW-V/30XWHV was designed for high performance both at full load and at part load.
  - Eurovent certified values per EN14511-3:2022: SEPR up to 8.07 and SEER up to 8.43
- High energy efficiency
  - Inverter-driven twin-rotor screw compressors allow precise capacity matching of building load changes and significantly reduce unit power input, especially at part-load.
  - Flooded multi-pipe heat exchangers for increased heat exchange efficiency.
  - Electronic expansion device permits operation at a lower condensing pressure and improved utilisation of the evaporator heat exchange surface.
- Optimised electrical performance
  - All 30XW-V/30XWHV units comply with class 3 of standard EN61800-3. Category C3 refers to industrial environments. With option 282 category C2 compliance is possible.
  - Inverter-driven motors ensure negligible start-up current (value is lower than the maximum unit current draw)

### High reliability

- The 30XW-V and 30XWHV ranges offer increased global performance as well as Carrier's acclaimed product quality and reliability. Major components are selected and tested to minimize failures possibility, as well as many design choices have been taken in this perspective.
- Inverter-driven screw compressors
  - Industrial-type screw compressors with oversized bearings and motor cooled by suction gas.
  - The inverter is optimised for each compressor motor to ensure reliable operation and easy maintenance.
  - All compressor components are easily accessible on site minimising down-time.
- Refrigerant circuits
  - Two independent refrigerant circuits (from 1000 kW upwards); the second one automatically takes over, if the first one develops a fault, maintaining partial cooling under all circumstances.
- Evaporator
  - Electronic paddle-free flow switch. Auto-setting according to cooler size and fluid type.
- Auto-adaptive control
  - Control algorithm prevents excessive compressor cycling
  - Automatic compressor unloading in case of abnormally high condensing pressure or discharge temperature.
- Exceptional endurance tests
  - Partnerships with specialised laboratories and use of limit simulation tools (finite element calculation) for the design of critical components.
  - Transport simulation test in the laboratory on a vibrating table and then on an endurance circuit (based on a military standard).

### Easy and fast installation

- Compact design
  - The 30XW-V/30XWHV units are designed to offer compact dimensions for easy installation.
  - With a width of approximately 1.25 m up to 1000 kW the units can pass through standard door openings and only require minimum floor space in the plant room.
- Simplified electrical connections
  - Main disconnect switch with high trip capacity
  - Transformer supply to the integrated control circuit (400/24 V)
- Simplified water connections
  - Victaulic connections on the evaporator and condenser
  - Practical reference marks for entering and leaving water connections
  - Possibility to reverse the heat exchanger water inlet and outlet at the factory
  - Possibility to modify the number of heat exchanger passes
- Fast commissioning
  - Systematic factory operation test before shipment
  - Quick-test function for step-by-step verification of the instruments, expansion devices and compressors.

### Minimised operating sound levels

- The inverter technology used for the compressor motors minimises noise levels at part load operation. In two-compressor units at 25% of the maximum load the unit sound power level is reduced by 10 dB(A).
- Standard unit features include:
  - Silencers on the compressor discharge line.
  - Sound insulation on the components that are most subjected to radiated noise.
- Option 257 further reduces the global unit sound level.

### Environmental care

- R-134a refrigerant
  - HFC-refrigerant with zero ozone depletion potential
- Leak-tight refrigerant circuit
  - Reduction of leaks as no capillary tubes and flare connections are used
  - Verification of pressure transducers and temperature sensors without transferring refrigerant charge
  - Discharge line shut-off valve and liquid line service valve for simplified maintenance.

### Designed to support green building design

- A green building is a building that is environmentally sustainable and has been designed, constructed and is operated to minimise the total impact on the environment. The underlying principles of this approach: The resulting building will be economical to operate, offer increased comfort and create a healthier environment for the people who live and work there, increasing productivity.

## CUSTOMER BENEFITS

- The air conditioning system can use between 30 and 40% of the annual building energy consumption. Selection of the right air conditioning system is one of the main aspects to consider when designing a green building. For buildings with a variable load throughout the year, 30XW-V/30XWHV units offers a solution to this important challenge.
- A number of green building certification programs exist in the market and offer third-party assessment of green building measures for a wide variety of building types.
- The following example looks at how Carrier's new 30XW-V/30XWHV range helps customers involved in LEED® building certification.

### 30XW-V/30XWHV and LEED® certification

The LEED® (Leadership in Energy and Environmental Design) green building certification programme is a pre-eminent programme to rate the design, construction and operation of green buildings with points assigned in seven credit categories:

- Sustainable Sites (SS)
- Water Efficiency (WE)
- Energy & Atmosphere (EA)
- Materials & Resources (MR)
- Indoor Environmental Quality (IEQ)
- Innovation in Design (ID)
- Regional Priority (RP)

There are a number of different LEED® products.

While the strategies and categories assessed remain same, the point distribution varies to address different building types and application needs, for example according to New Construction, Schools, Core & Shell, Retail and Healthcare. All programmes now use the same point scale:

### 110 Possible LEED® points

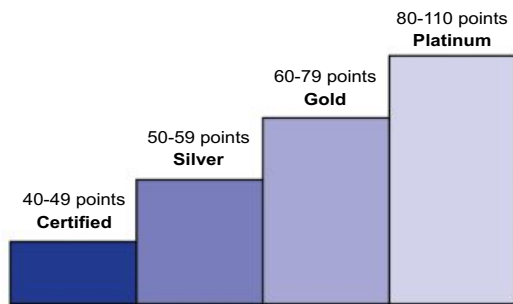

The majority of credits in LEED® rating systems are performance-based and achieving them is dependent on the impacts of each component or sub-system to the overall building.

While the LEED® green building certification programs do not certify products or services, the selection of the right products, systems or service programs is critical to obtain LEED® certification for a registered project, because the right products or service programmes can help meet the goals of green construction and ongoing operation and maintenance.

The choice of heating, ventilating and air conditioning (HVAC) products in particular can have a significant impact on LEED® certification, as the HVAC system directly impacts two categories that together influence 40% of the available points.

### Overview of LEED® for new construction and major renovations

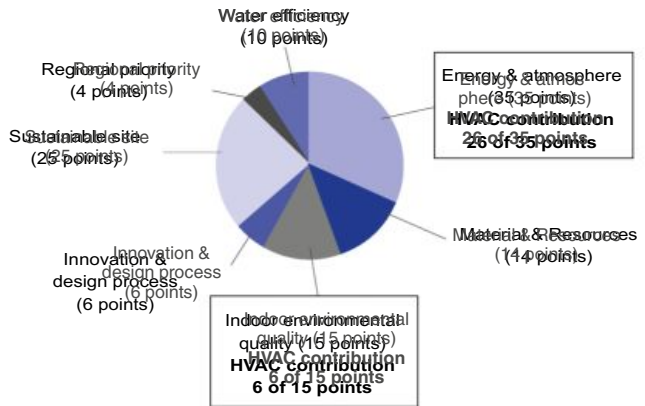

The new 30XW-V/30XWHV units from Carrier can assist building owners to earn LEED® points in particular in the Energy & Atmosphere (EA) credit category and help address the following prerequisites and credit requirements:

- **EA prerequisite 2: Minimum energy Performance**  
The 30XW-V/30XWHV exceeds the energy efficiency requirements of ASHRAE 90.1-2007; therefore it complies with the prerequisite standard.
- **EA prerequisite 3: Fundamental Refrigerant Management**  
The 30XW-V/30XWHV does not use chlorofluorocarbon (CFC) refrigerants thus satisfying the prerequisite statement.
- **EA credit 1: Optimise energy performance (1 to 19 points)**  
Points for this credit are assigned depending on the energy cost reduction virtually achievable by the new building, compared to ASHRAE 90.1-2007 reference. The 30XW-V/30XWHV, which is designed for high performance especially during part load operation, contributes reducing the energy consumption of the building and therefore helps gaining points within this credit. In addition, the Carrier HAP (Hourly Analyses Program) can be used as an energy analyses program complying with the modeling requirements for this credit and produce reports that are easily transferable to LEED® templates.
- **EA credit 4: Enhanced refrigerant management (2 points)**  
With this credit, LEED® awards systems that minimise the Ozone Depletion Potential (ODP) and Global Warming Potential (GWP) of the system. The 30XW-V/30XWHV uses a reduced R134a charge and therefore contributes toward satisfying this credit under LEED®.

**NOTE: This section describes the prerequisites and credit requirements in LEED® for New Construction and is directly related to the 30XW-V/30XWHV. Other prerequisites and credit requirements are not directly and purely related to the air-conditioning unit itself, but more to the control of the complete HVAC system.**

i-Vu®, Carrier's open control system, has features that can be valuable for:

- EA prerequisite 1: Fundamental commissioning of energy management system
- EA credit 3: Enhanced commissioning (2 points)
- EA credit 5: Measurements and verification (3 points).

**NOTE: Products are not reviewed or certified under LEED®. LEED® credit requirements cover the performance of materials in aggregate, not the performance of individual products or brands. For more information on LEED®, visit [www.usgbc.org](http://www.usgbc.org).**

## TECHNICAL INSIGHTS

### SmartVu™



- New innovative smart control features :
  - An intuitive and user-friendly, coloured, 7" interface
  - 10 languages available on choice: DE, EN, ES, FR, T, NL, PT, TR, TU + one additional customer choice
  - Screen-shots with concise and clear information in local languages
  - Complete menu, customised for different users (end user, service personnel and Carrier-factory technicians)
  - Setpoint offset based on the outside air temperature
  - Safe operation and unit setting: Password protection ensures that unauthorised people cannot modify any advanced parameters
  - Simple and "smart" intelligence uses data collection from the constant monitoring of all machine parameters to optimise unit operation
  - Night-mode: Cooling capacity management for reduced noise level.
  - With hydraulic module: Water pressure display and water flow rate calculation.
- Energy management :
  - Internal time schedule clock controls chiller on/off times and operation at a second set-point
  - The DCT (Data Collection Tool) records the alarms history to simplify and facilitate service operations.
- Maintenance functions :
  - F-Gas regulation leak check reminder alert
  - Maintenance alert can be configured to days, months or hours of operation
- Advanced communication features :
  - Easy and high-speed communication technology over Ethernet (IP) to a centralised building management system
  - Access to multiple unit parameters.

### Remote Management (Standard)

- Units with SmartVu™ control can be easily accessed from the internet, using a PC with an Ethernet connection. This makes remote control quick and easy and offers significant advantages for service operations.
- Aquaforce with Greenspeed® Intelligence is equipped with an RS485 serial port that offers multiple remote control, monitoring and diagnostic possibilities. When networked with other Carrier equipment through the CCN (Carrier Comfort Network - proprietary protocol), all components form a HVAC system fully-integrated and balanced through one of the Carrier's network system products, like the Chiller System analyzer or the Plant System analyzer (optional).
- The chiller also communicates with other building management systems via optional communication gateways (BACnet, LON or JBus).
- The following commands/visualisations are possible from remote connection:
  - Start/Stop of the machine
  - Dual set-point management: Through a dedicated contact is possible to activate a second set-point (example, unoccupied mode)
  - Demand limit setting: To limit the maximum chiller capacity to a predefined value
  - Water pump control: These outputs control the contactors of one/two evaporator water pumps.
  - Water pumps changeover (only with hydraulic module options): These contacts are used to detect a water pump operation fault and automatically change over to the other pump.
  - Operation visualisation: indication if the unit is operating or if it is in stand-by (no cooling load)
  - Alarm visualisation.

### Remote management (EMM option)

- The Energy Management Module offers extended remote control possibilities:
  - Room temperature: Permits set-point reset based on the building indoor air temperature (if Carrier thermostats are installed)
  - Set-point reset: Allows reset of the cooling set-point based on a 4-20 mA or 0-10 V signal
  - Demand limit: Permits limitation of the maximum chiller capacity based on 0-10 V signal
  - Demand limit 1 and 2: Closing of these contacts limits the maximum chiller capacity to two predefined values.
  - User safety: This contact can be used for any customer safety loop; opening the contact generates a specific alarm.
  - Ice storage end: When ice storage has finished, this input permits return to the second set-point (unoccupied mode).
  - Time schedule override: Closing of this contact cancels the programmed time schedule.
  - Out of service: This signal indicates that the chiller is completely out of service.
  - Chiller capacity: This analogue output (0-10 V) gives an immediate indication of the chiller capacity.
  - Alert indication: This volt-free contact indicates the necessity to carry out a maintenance operation or the presence of a minor fault.
  - Compressors running status: Set of outputs (as many as the compressors number) indicating which compressors are running.

## TECHNICAL INSIGHTS

### Remote management (EMM option)

The Energy Management Module offers extended remote control possibilities:

- Room temperature: permits set-point reset based on the building indoor air temperature (with Carrier thermostat)
- Set point reset: ensures reset of the cooling set-point based on a 4-20 mA or 0-10 V signal
- Demand limit: permits limitation of the maximum chiller power or current based on a 0-10 V signal
- Demand limit 1 and 2: closing of these contacts limits the maximum chiller power or current to two predefined values
- User safety: this contact can be used for any customer safety loop; opening the contact generates a specific alarm
- Ice storage end: when ice storage has finished, this input permits return to the second set-point (unoccupied mode)
- Time schedule override: closing of this contact cancels the time schedule effects
- Out of service: this signal indicates that the chiller is completely out of service
- Chiller capacity: this analogue output (0-10 V) gives an immediate indication of the chiller capacity
- Alert indication: this volt-free contact indicates the necessity to carry out a maintenance operation or the presence of a minor fault.
- Compressors running status : set of outputs (as many as the compressors number) indicating which compressors are running.

### New inverter-driven Thunderbolt screw compressor

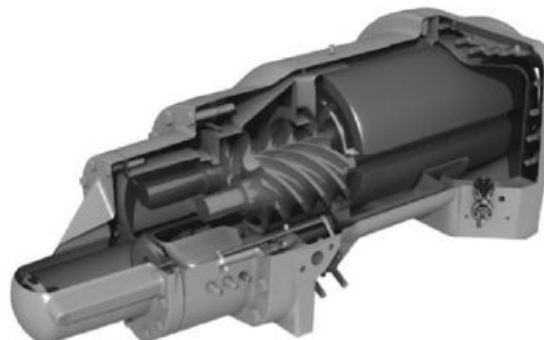

- The new generation of Carrier inverter-driven screw compressors benefits from Carrier's long experience in the development of twin-rotor screw compressors. The design of the Thunderbolt compressors is based on the successful 06T screw compressor, core of the well-known Aquaforce series.
- Advanced control algorithms combine inverter frequency output with motor input logic to minimise mechanical part stress, resulting in best compression performance and high chiller reliability. The compressor is equipped with bearings with oversized rollers, oil pressure lubricated for reliable and durable operation, even at maximum load.
- Screw compressors use positive displacement principle to compress gases at higher pressure. As a result, in case of exceptional high temperature condenser side (due for example to water-pipes fouling or operation in harsh climate with an external dry cooler) the compressor does not switch off, but continues operation at reduced capacity (unloaded mode).
- The silencer in the discharge line considerably reduces discharge gas pulsations for much quieter operation.
- The condenser includes an oil separator that minimises the amount of oil in circulation in the refrigerant circuit and re-directs it to the compressor function.

### Digit number

1	2	3	4	5	6	7	8	9	10	11	12	13	14	15	16	17	18
3	0	X	W	-	V	0	2	5	4	B	0	0	0	1	-		

**Legend :**

- Digit 1 to 4: Water-cooled chiller with screw compressor
- Digit 5: Application type, - = Cooling, H = Heating
- Digit 6: Efficiency, V = Variable
- Digit 7 to 10: Model number based on cooling capacity in kW
- Digit 11: Index for major product modification (visible impact for customer)
- Digit 12 to 15: Counter used to generate a one time product code
- Digit 16: Not used



## OPTIONS

Options	No.	Description	Advantages	Use
Light-brine solution, down to -3°C	8	Implementation of new algorithms of control to allow chilled brine solution production down to -3°C when ethylene glycol is used (0°C with propylene glycol)	Matches with most application requirements for ground-sourced heat pumps and fits with many industrial processes requirements	580-1710 (see dedicated paragraph)
Master/slave operation	58	Unit equipped with supplementary water outlet temperature sensor kit to be field-installed allowing master/slave operation of two units connected in parallel	Optimised operation of two chillers connected in parallel with operating time equalisation	580-1710
Single power connection point	81	Unit power connection via one main supply connection	Quick and easy installation	1150-1710
Evap. pump power/control circuit	84	Unit equipped with an electrical power and control circuit for one pump evaporator side	Quick and easy installation: the control of fixed speed pumps is embedded in the unit control	580-1710
Evaporator dual pumps electrical power / control circuit	84D	Unit equipped with an electrical power and control circuit for two pumps evaporator side	Quick and easy installation: the control of fixed speed pumps is embedded in the unit control	580-1710
Cond. pump power/control circuit	84R	Unit equipped with an electrical power and control circuit for one pump condenser side	Quick and easy installation: the control of fixed speed pumps is embedded in the unit control	580-1710
Cond. dual pumps power/control circuit	84T	Unit equipped with an electrical power and control circuit for two pumps condenser side	Quick and easy installation: the control of fixed speed pumps is embedded in the unit control	580-1710
Condenser insulation	86	Thermal condenser insulation	Minimizes thermal dispersions condenser side (key option for heat pump or heat recovery applications) and allows compliancy with special installation criteria (hot parts insulated)	580-1710
Service valve set	92	Liquid line valve (evaporator inlet) and compressor suction line valve	Allow isolation of various refrigerant circuit components for simplified service and maintenance	580-1710
Evaporator with one pass less	100C	Evaporator with one pass on the water side. Evaporator inlet and outlet on opposite sides.	Easy to install, depending on site. Reduced pressure drops	580-1710
Condenser with one pass less	102C	Condenser with one pass on the water side. Condenser inlet and outlet on opposite sides.	Easy to install, depending on site. Reduced pressure drops	580-1710
21 bar evaporator	104	Reinforced evaporator for extension of the maximum water-side service pressure to 21 bar (standard 10 bar)	Covers applications with a high water column evaporator side (typically high buildings)	580-1710
21 bar condenser	104A	Reinforced condenser for extension of the maximum water-side service pressure to 21 bar (standard 10 bar)	Covers applications with a high water column condenser side (typically high buildings)	580-1710
Reversed evaporator water connections	107	Evaporator with reversed water inlet/outlet	Easy installation on sites with specific requirements	580-1710
Reversed condenser water connections	107A	Condenser with reversed water inlet/outlet	Easy installation on sites with specific requirements	580-1710
LON gateway	148D	Two-directional communication board complying with LON protocol	Connects the unit by communication bus to a building management system	580-1710
Bacnet over IP gateway	149	Two-directional high-speed communication using BACnet protocol over Ethernet network (IP)	Easy and high-speed connection by ethernet line to a building management system. Allows access to multiple unit parameters	580-1710
Modbus over IP and RS485	149B	Bi-directional high-speed communication using Modbus protocol over Ethernet network (IP)	Easy and high-speed connection by ethernet line to a building management system. Allows access to multiple unit parameters	580-1710
Condensing temperature limitation	150B	Limitation of the maximum condenser leaving water temperature to 45°C	Reduced maximum power input and current absorption: power cables and protection elements can therefore be downsized	580-1710
Control for low condensing temperature systems	152	Output signal (0-10 V) to control the condenser water inlet valve	Simple installation: for applications with cold water at condenser inlet (ex. ground-source, groundwater-source, superficial water-source applications) the signal permits to control a 2 or 3-way valve to maintain condenser water temperature (and so condensing pressure) at acceptable values	580-1710
Energy Management Module EMM	156	Control board with additional inputs/outputs. See Energy Management Module option chapter	Extended remote control capabilities (Set-point reset, ice storage end, demand limits, boiler on/off command...)	580-1710
Leak detection	159	0-10 V signal to report any refrigerant leakage in the unit directly on the controller (the leak detector itself must be supplied by the customer)	Immediate customer notification of refrigerant losses to the atmosphere, allowing timely corrective actions	580-1710



## OPTIONS

Options	No.	Description	Advantages	Use
Dual relief valves on 3-way valve	194	Three-way valve upstream of dual relief valves on the evaporator and the oil separator	Valve replacement and inspection facilitated without refrigerant loss. Comforms to European standard EN378/BGVD4	580-1710
Compliance with Swiss regulations	197	Additional tests on the water heat exchangers: supply (additional of PED documents) supplementary certificates and test certifications	Conformance with Swiss regulations	580-1710
Compliance with Russian regulations	199	EAC certification	Conformance with Russian regulations	580-1710
Compliance with Australian regulations	200	Unit approved to Australian code	Conformance with Australian regulations	580-1710
Low noise level	257	Evaporator sound insulation	3 dB(A) quieter than standard unit	580-1710
Welded evaporator water connection kit	266	Victaulic piping connections with welded joints	Easy installation	580-1710
Welded condenser water connection kit	267	Victaulic piping connections with welded joints	Easy installation	580-1710
Flanged evaporator water connection kit	268	Victaulic piping connections with flanged joints	Easy installation	580-1710
Flanged condenser water connection kit	269	Victaulic piping connections with flanged joints	Easy installation	580-1710
Thermal compressor insulation	271	The compressor is covered with a thermal insulation layer	Prevents air humidity to condensate on the compressor surface	580-1710
EMC classification C2, as per EN 61800-3	282	Additional RFI filters on the unit power line	Reduces electromagnetic interferences. Increase the variable frequency drive (VFD) immunity level according to first environment (so called, residential environment) requirements and allow its compliancy with emissions level required in category C2	580-1710
Fast Capacity Recovery	295	New software algorithms to allow quick restart and fast loading while preserving unit-reliability	Full capacity recovery in approximately 6 minutes after power failure. Matches requirements of typical critical missions applications	580-1710
Compliance with UAE regulation	318	Additional label on the unit with rated power input, rated current and EER following AHRI 550/590	Compliance with ESMA standard UAE.S 5010-5:2019.	580-1710
Compliance with Morocco regulation	327	Specifics documents according Morroco regulation	Conformance with Morocco regulations	580-1710

PHYSICAL DATA, 30XW-V UNITS

30XW-V / 30XWHV			580	630	810	880	1150	1280	1470	1570	1710	
<b>Heating</b>												
<b>Standard unit</b> Full load performances *	HW1	Nominal capacity	kW	649	719	890	974	1261	1428	1594	1761	1932
		COP	kW/kW	4,64	4,53	4,56	4,43	4,62	4,61	4,55	4,33	4,16
	HW2	Nominal capacity	kW	687	767	956	1021	1335	1524	1712	1898	2067
		COP	kW/kW	6,15	5,98	5,96	5,81	6,05	6,00	5,82	5,49	5,34
<b>Standard unit</b> Seasonal energy efficiency **	HW2	SCOP <sub>30/35°C</sub>	kWh/kWh	7,32	7,05	7,21	6,96	6,95	6,66	6,37	6,13	5,87
		η <sub>s heat</sub> <sub>30/35°C</sub>	%	285	274	280	270	270	259	247	237	227
		P <sub>rated</sub>	kW	818	913	1134	1216	1589	1815	2041	2263	2463
<b>Cooling</b>												
<b>Standard unit</b> Full load performances *	CW1	Nominal capacity	kW	587	652	812	858	1140	1305	1461	1604	1741
		EER	kW/kW	5,44	5,31	5,25	5,07	5,45	5,50	5,38	5,05	4,94
	CW2	Nominal capacity	kW	704	754	910	863	1364	1508	1581	1876	2040
		EER	kW/kW	6,46	6,08	5,80	5,22	6,38	6,19	5,55	5,60	5,63
<b>Standard unit</b> Seasonal energy efficiency**		<b>SEER<sub>12/7°C</sub> Comfort low temp.</b>	<b>kWh/kWh</b>	<b>7,94</b>	<b>7,62</b>	<b>8,43</b>	<b>7,93</b>	<b>8,31</b>	<b>8,19</b>	<b>7,74</b>	<b>7,70</b>	<b>7,34</b>
		η <sub>s cool</sub> <sub>12/7°C</sub>	%	315	302	334	314	329	325	307	305	290
		SEPR <sub>12/7°C</sub> Process high temp.	kWh/kWh	8,07	8,02	7,73	6,76	8,04	8,07	7,96	7,89	7,49
Integrated Part Load Value IPLV.SI			kW/kW	9,060	9,120	9,450	8,950	9,240	9,300	9,170	9,300	8,980
<b>Sound levels - standard unit</b>												
Sound power level <sup>(1)</sup>			dB(A)	105	105	105	105	106	106	106	106	106
Sound pressure level at 1 m <sup>(2)</sup>			dB(A)	87	87	87	87	87	87	87	87	87
<b>Sound levels - standard unit + option 257 <sup>(3)</sup></b>												
Sound power level <sup>(1)</sup>			dB(A)	102	102	102	102	103	103	103	103	103
Sound pressure level at 1 m <sup>(2)</sup>			dB(A)	84	84	84	84	84	84	84	84	84
<b>Dimensions - standard unit</b>												
Length			mm	3059	3059	3290	3290	4730	4730	4730	4730	4730
Width			mm	1087	1087	1237	1237	1164	1164	1255	1255	1255
Height			mm	1743	1743	1950	1950	1997	1997	2051	2051	2051
Operating weight <sup>(4)</sup>			kg	3152	3190	4157	4161	7322	7398	7574	7770	7808
<b>Compressors</b>												
Semi-hermetic 06T screw compressors, 60 r/s												
Circuit A			-	1	1	1	1	1	1	1	1	1
Circuit B			-	-	-	-	1	1	1	1	1	1

\* In accordance with standard EN14511-3:2022.  
 \*\* In accordance with standard EN14825:2022, average climate  
 HW1 Heating mode conditions: Evaporator entering/leaving water temperature 10°C/7°C, condenser entering/leaving water temperature 40°C/45°C, evaporator and condenser fouling factor 0 m<sup>2</sup>. k/W  
 HW2 Heating mode conditions: Evaporator entering/leaving water temperature 10°C/7°C, condenser entering/leaving water temperature 30°C/35°C, evaporator and condenser fouling factor 0 m<sup>2</sup>. k/W  
 CW1 Cooling mode conditions: Evaporator water entering/leaving temperature 12°C/7°C, condenser entering/leaving water temperature 30°C/35°C, evaporator and condenser fouling factor 0 m<sup>2</sup>.K/W  
 CW2 Cooling mode conditions: Evaporator water entering/leaving temperature 23°C/18°C, condenser entering/leaving water temperature 30°C/35°C, evaporator and condenser fouling factor 0 m<sup>2</sup>.K/W  
 (1) In dB ref=10<sup>-12</sup> W, (A) weighting. Declared dualnumber noise emission values in accordance with ISO 4871 (with an associated uncertainty of +/-3dB(A)). Measured in accordance with ISO 9614-1 and certified by Eurovent.3dB(A)). Measured in accordance with ISO 9614-1 and certified by Eurovent.  
 (2) in dB ref 20μPa, (A) weighting. Declared dualnumber noise emission values in accordance with ISO 4871 (with an associated uncertainty of +/-3dB(A)). For information, calculated from the sound power level Lw(A).  
 (3) Option 257 = Low noise level  
 (4) Weight shown is guideline only. To find out the unit refrigerant charge, please refer to the unit nameplate  
 η<sub>s heat</sub><sub>30/35°C</sub> & SCOP<sub>30/35°C</sub> Values calculated in accordance with EN14825:2022  
 η<sub>s cool</sub><sub>12/7°C</sub> & SEER<sub>12/7°C</sub> **Bold values compliant to Ecodesign regulation: (EU) No 2016/2281 for Comfort application**  
 SEPR<sub>12/7°C</sub> Values calculated in accordance with EN14825:2022  
 NA Non Authorized for the specific application for CEE market  
 IPLV.SI Calculations according to standard performances AHRI 551-591 (SI).



Eurovent certified values



AHRI certified values  
30XW-V only

## PHYSICAL DATA, 30XW-V UNITS

30XW-V / 30XWHV		580	630	810	880	1150	1280	1470	1570	1710
<b>Oil - standard unit</b>										
Circuit A	l	32	32	36	36	32	32	36	36	36
Circuit B	l	-	-	-	-	32	32	32	36	36
<b>Refrigerant - standard unit</b>		R-134a, GWP=1430 following ARI4								
Circuit A	kg	130	130	180	175	120	120	115	115	110
	teqCO <sub>2</sub>	186	186	257	250	172	172	164	164	157
Circuit B	kg	-	-	-	-	120	120	120	115	110
	teqCO <sub>2</sub>	-	-	-	-	172	172	172	164	157
<b>Capacity control</b>		SmartVu™, inverter-driven compressor, electronic expansion valve (EXV)								
Minimum capacity	%	30	30	15	15	30	30	15	15	15
<b>Evaporator</b>		Multi-pipe flooded type								
Water volume	l	106	106	154	154	297	297	297	297	297
Water connections (Victaulic)	in	6	6	8	8	8	8	8	8	8
Drain and vent connections (NPT)	in	3/8	3/8	3/8	3/8	3/8	3/8	3/8	3/8	3/8
Max. water-side operating pressure	kPa	1000	1000	1000	1000	1000	1000	1000	1000	1000
<b>Condenser</b>		Multi-pipe flooded type								
Water volume	l	112	112	165	165	340	340	340	340	340
Water connections (Victaulic)	in	6	6	8	8	8	8	8	8	8
Drain and vent connections (NPT)	in	3/8	3/8	3/8	3/8	3/8	3/8	3/8	3/8	3/8
Max. water-side operating pressure	kPa	1000	1000	1000	1000	1000	1000	1000	1000	1000

## ELECTRICAL DATA

30XW-V/30XWHV		580	630	810	880	1150	1280	1470	1570	1710
<b>Power circuit</b>										
Nominal power supply	V-ph-Hz	400-3-50								
Voltage range	V	360-440								
<b>Control circuit</b>										
24 V via the built-in transformer										
<b>Start-up current*</b>										
A Lower than the operating current										
<b>Maximum power factor**</b>										
		0,91-0,93	0,91-0,93	0,91-0,93	0,91-0,93	0,91-0,93	0,91-0,93	0,91-0,93	0,91-0,93	0,91-0,93
<b>Cosine phi</b>										
		>0,98	>0,98	>0,98	>0,98	>0,98	>0,98	>0,98	>0,98	>0,98
<b>Total harmonic distortion†</b>										
	%	35-45	35-45	35-45	35-45	35-45	35-45	35-45	35-45	35-45
<b>Maximum power input***</b>										
Circuit A	kW	155	193	222	246	155	193	222	222	246
Circuit B	kW	-	-	-	-	155	193	193	222	246
With option 81	kW	-	-	-	-	310	386	415	444	492
<b>Eurovent current draw****</b>										
Circuit A	A	175	200	240	265	175	200	240	240	265
Circuit B	A	-	-	-	-	175	200	200	240	265
With option 81	A	-	-	-	-	350	400	440	480	530
<b>Maximum current draw (Un)***</b>										
Circuit A	A	245	300	346	383	245	300	346	346	383
Circuit B	A	-	-	-	-	245	300	300	346	383
With option 81	A	-	-	-	-	490	600	646	692	766
<b>Maximum current draw (Un -10%)***</b>										
Circuit A	A	270	330	380	421	270	330	380	380	421
Circuit B	A	-	-	-	-	270	330	330	380	421
With option 81	A	-	-	-	-	540	660	710	760	842
<b>Maximum power input with option 150B***</b>										
Circuit A	kW	141	173	199	221	141	173	199	199	221
Circuit B	kW	-	-	-	-	141	173	173	199	221
With option 81	kW	-	-	-	-	282	346	372	398	442
<b>Maximum current draw (Un) with option 150B***</b>										
Circuit A	A	222	272	314	348	222	272	314	314	348
Circuit B	A	-	-	-	-	222	272	272	314	348
With option 81	A	-	-	-	-	444	544	586	628	696
<b>Dissipated power†</b>										
	W	3000	4200	4700	5300	6000	8400	8900	9400	10600

\* Instantaneous start-up current

\*\* This can vary as a function of the short-circuit current/maximum current ratio of the system transformer. Values obtained at operation with maximum unit power input.

\*\*\* Values obtained at operation with maximum unit power input. Values given on the unit name plate.

\*\*\*\* Eurovent unit operating conditions: evaporator entering/leaving water temperature = 12°C/7°C, condenser entering/leaving water temperature = 30°C/35°C. Gross performances, not in accordance with EN14511-3:2022. These performances do not take into account the correction for the proportional heating capacity and power input generated by the water pump to overcome the internal pressure drop in the heat exchanger.

† Values obtained at operation with maximum unit power input.

## DIMENSIONS/CLEARANCES

### 30XW-V/30XWHV 580-880

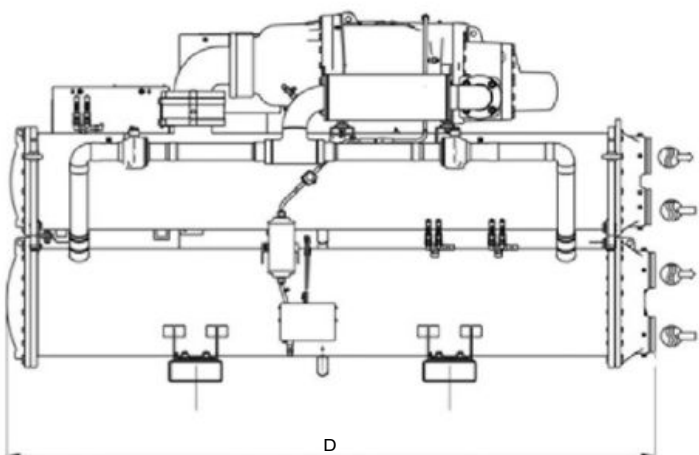
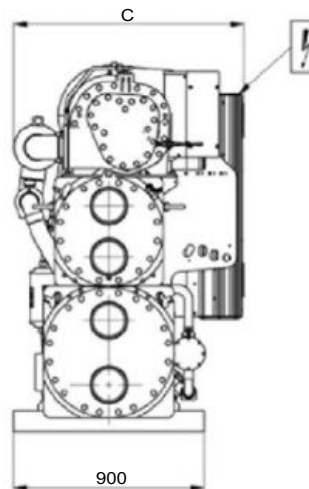
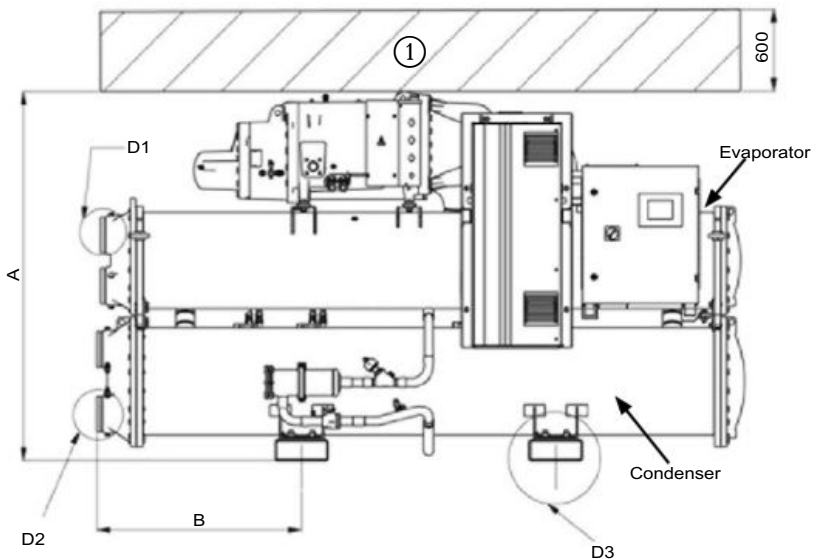

Dimensions in mm							
	A	B	C	D	E	F	G
<b>30XW-V/30XWHV</b>							
<b>580</b>	1743	968	1087	3059	168,3	168,3	2900
<b>630</b>	1743	968	1087	3059	168,3	168,3	2900
<b>810</b>	1950	1083	1237	3290	219,1	219,1	3100
<b>880</b>	1950	1083	1237	3290	219,1	219,1	3100

**Legend:**

All dimensions are in mm.

- ① Required clearance for maintenance
- ② Recommended clearance for tube removal
- Water inlet
- Water outlet
- Power supply connection

**NOTE:** Drawings are not contractually binding. Before designing an installation, consult the certified dimensional drawings, available on request.

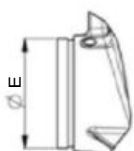
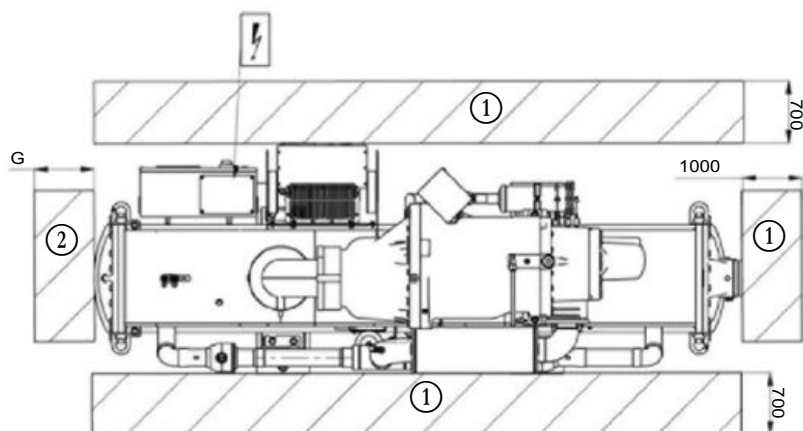

D1

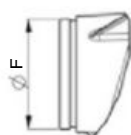

D2

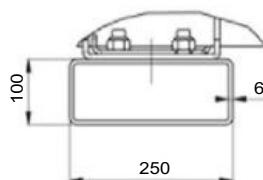

D3



## DIMENSIONS/CLEARANCES

30XW-V/30XWHV 1150-1710

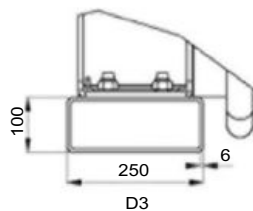
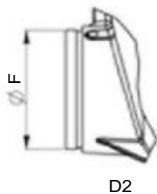
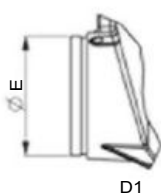
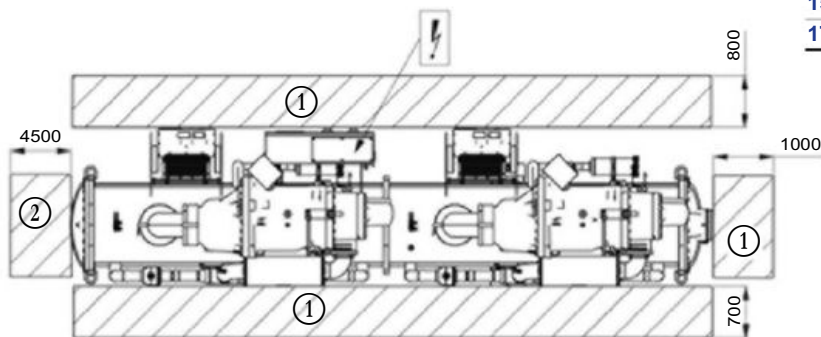
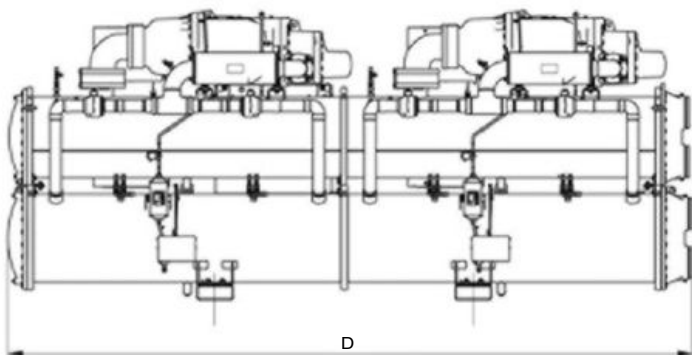
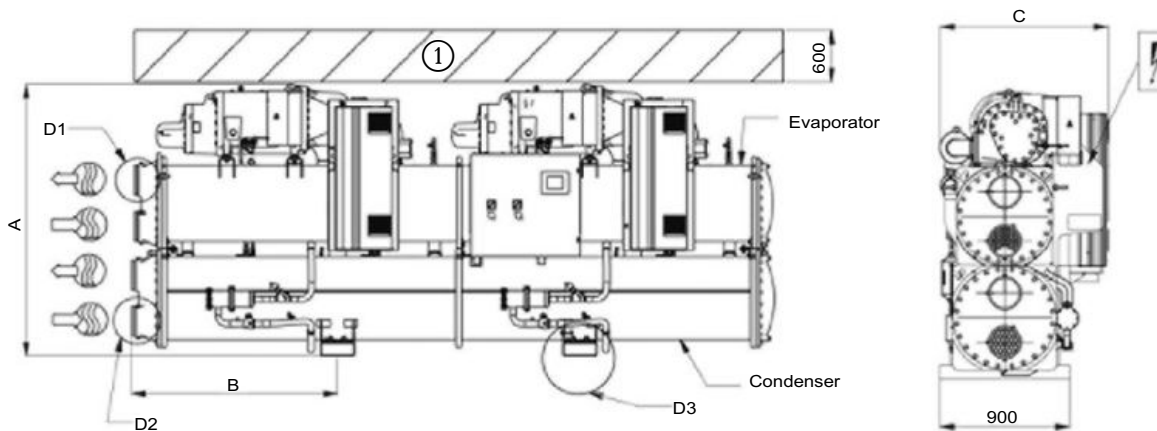

Dimensions in mm						
	A	B	C	D	E	F
<b>30XW-V/30XWHV</b>						
<b>1150</b>	1997	1514	1164	4730	219,1	219,1
<b>1280</b>	1997	1514	1164	4730	219,1	219,1
<b>1470</b>	2051	1514	1255	4730	219,1	219,1
<b>1570</b>	2051	1514	1255	4730	219,1	219,1
<b>1710</b>	2051	1514	1255	4730	219,1	219,1

**Legend:**

All dimensions are in mm.

- ① Required clearance for maintenance
- ② Recommended clearance for tube removal
- Water inlet
- Water outlet
- Power supply connection

**NOTE:** Drawings are not contractually binding. Before designing an installation, consult the certified dimensional drawings, available on request.



# CERAMIC BEARING CENTRIFUGAL LIQUID CHILLER WITH PURETEC™ REFRIGERANT AND GREENSPEED® INTELLIGENCE



- Reliability
- Efficiency
- Acoustic comfort
- Flexibility
- Footprint

## 19DV3/4/5\*



Nominal cooling capacity: 1200 - 3600 kW

Designed to perfectly meet the new requirements in terms of energy performance, acoustic comfort, refrigerant sustainability, low maintenance and total cost of ownership, the 19DV is the new standard for the medium cooling capacity centrifugal chiller market.

\* 19DV5 3000-3800 kW available Q4/2022



CARRIER participates in the ECP programme for LCP-HP  
Check ongoing validity of certificate:  
[www.eurovent-certification.com](http://www.eurovent-certification.com)

## FEATURES AND BENEFITS

### Reliable

Advanced back-to-back two-stage compressor naturally balances both radial and axial thrust on shaft.

Simple and robust ceramic bearing system enables refrigerant lubrication that doesn't request oil lubrication which is requested by conventional chillers. Customers won't be troubled by oil related failures as well as maintenance cost and efforts.

High tier variable speed starter equipped with harmonic filter(optional), total harmonic distortion (THD)  $\leq 5\%$  and fully complies with IEEE519 standard.

Swift restart - 19DV can restart within 30 seconds (with UPS) after power recovery and achieve to required cooling load more rapidly, especially reliable for data center application.

### Efficient

Carrier back-to-back two-stage compressor integrated with inter-stage economizer which improves both cooling capacity and efficiency.

High speed direct drive motor reduces mechanical loss by 75% resulting from the removal of gear driven system.

By application of refrigerant lubricated ceramic bearings, the efficiency decline by oil in heat exchangers is not existed in 19DV.

Pioneer falling film evaporator is designed for low pressure refrigerant, which performs a significantly enhanced heat transfer efficiency by mitigating submergence effect especially at part load conditions.

High performance tubing with internally and externally enhanced fins improves chiller efficiency by reducing overall resistance to heat transfer.

Greenspeed® variable speed control gives a moment-to-moment control of compressor speed to adapt building load changes perfectly, which ensures the chiller always operating efficiently at both full load and part load.

19DV chillers can achieve up to 7.0 full load COP and 11.8 IPLV at AHRI conditions.

### Sustainable

R-1233zd(E) is new non-Ozone Depletion Substances, the ultra low Global Warming Potential of  $\sim 1$ , non-flammability and non-toxicity refrigerant that provides a safe and environmentally steward solution to centrifugal chillers.

Carrier pioneer falling film evaporator design helps reduce the refrigerant charge significantly.

The industry leading energy efficiency of 19DV chiller leads to lower electrical power consumption and significant reduction of related CO<sub>2</sub> emissions.

### Flexible

System layout of 19DV chillers is well optimized and specific crescent shape economizer is designed to best leverage the space between evaporator and condenser that brings up to -15% smaller footprint versus legacy R-123 unit.

Patented re-locatable control panel could be installed at any of the four corners of the chiller, which makes the layout of chillers more flexible to fit the site conditions.

Bolt together modular design is ideal for retrofit project or installation in limited place.

Miscellaneous optional offerings (such as marine water box) help to facilitate daily maintenance on jobsite.

### Quiet

Refrigerant-cooled hermetic motor, no gear driven, optimized flow channel and 60% impeller speed of legacy design, all these features contribute to reduce refrigerant airflow noise.

Greenspeed® variable speed control adaptively turns down impeller speed at part load for better acoustic performance.

19DV chillers can meet 18001 standard recommended by Occupational Health and Safety Advisory Services (OHSAS).

### Smart

PIC6+ intelligent control - color touch screen, intuitive menu, animated component level interface, graphic trending, auto pushed alarm mail, smart password and more than 10 languages for choice.

Multiple remote access methods present the users a flexible way to monitor and control the chillers.

Carrier lifecycle data management system supports online data management and analysis, daily and key performance reports, prognostics and preventative maintenance, which will help the users continuously optimize the chiller and system operation.

### Carrier PIC6+ Control System - Intelligent Colorful Touch Screen

Carrier two-stage centrifugal chiller equips the latest PIC6+ control system with strong control and monitoring function during chiller operation. The control system applies a 10.4 inch high resolution touch screen, which can support more than ten language choices for customer, real time display of operation parameters with pictures makes it more human friendly and comfortable interface for operation. The control system simulates and monitors chiller operation, adjusts cooling or heating capacity according to load change and provides various protections during operation.



## FEATURES AND BENEFITS

### Reliable Start-up and Operation

PIC6+ control system provides customer the smart password to avoid any setting change without authorization.

When chiller receives start-up order, controller will conduct following pre-start safety checking, to ensure parameters like condensing pressure, bearing temperature, motor winding temperature, discharge temperature, evaporator saturated temperature and average line voltage etc. are normal.

During chiller operation, except for the function of monitoring main operation parameters the control system also has capability to record and display trend curve, which is real time trend of key components during operation. It ensures effective and reliable operation of chiller by optimized intelligent and dynamic control algorithm.

The control system has comprehensive protection during operation, such as surge protection, overvoltage and overcurrent protection, discharge temperature overheat protection, bearing temperature overheat protection, evaporator and condenser anti-freeze protection, low discharge superheat protection etc. in order to ensure chiller long time reliable operation.

The optional envelope stability control is advanced parametric solution to control both chiller system and compressor to best balance the chiller efficiency and reliability. In real time, the controller optimizes compressor speed, guide vane position and stabilizer valve position to find the most efficient operating point throughout the operating range, without comprising the chiller stability.

### Effective Failure Diagnostic

The PIC6+ control system has failure diagnostic function and can be easily accessed via touch screen for detail chiller operation parameters. If control system detects failure the alarm will be initiated and related code will be recorded in alarm menu. The alarm records can be automatically saved by control system. Carrier service technician can read and delete alarm records by Carrier service/PCDCT tools.

The control system has additional pre-diagnostic function. Different with diagnostic function, information displayed from this function is mainly for maintenance purpose. For an example, to inform customer periodically replace filter from this function.

The control system has email alarm function. The control system can automatically send out an email with one or more alarm information to customer or service people through effective email address when alarm exists.

### Flexible Interface and Connection

The installation of Carrier colorful touch screen is very flexible. It greatly improves the convenience that customer can install touch screen at any corner of the chiller.

The customer can not only directly operate on touch screen but also use the port to connect with BMS system. The control system facilitates various accesses, such as CCN to meet customer requirements. PIC6+ is compatible with Carrier i-Vu control network and integrated BACnet/IP protocol. PIC6+ also facilitates protocol such as native Modbus and converter for LonWorks to simplify the seamless connection with building automation systems.

Carrier LDMS (Lifecycle Data Management System) is based on "Big Data Processing" and supports more value-added customer service such as online data management and analysis, daily and key performance reports, prognostics and preventative maintenance. The enhanced data management and analysis will help the users to achieve continuous optimization of the chiller and system operation.

### Main Page

Control system main page operation and primary parameters monitored:

- Main page button
- Menu page button
- Log in/Language button
- Start-up/Stop page button
- Alarm menu button
- Setting point
- Chiller load percentage
- Inlet Guide Vane position percentage
- Condensing water pump status
- Chilled water pump status
- Condenser water inlet/outlet temperature
- Evaporator water inlet/outlet temperature
- Condenser saturated temperature and pressure
- Evaporator saturated temperature and pressure

Customer can easily read the primary information of chiller, components status and access to other interfaces from this page. They are:

- General parameter page
- Temperature/Pressure page
- Input/Output parameter page
- Water system parameter page
- Operation time
- Mode
- Graphic data trend

## DIMENSIONS/CLEARANCE

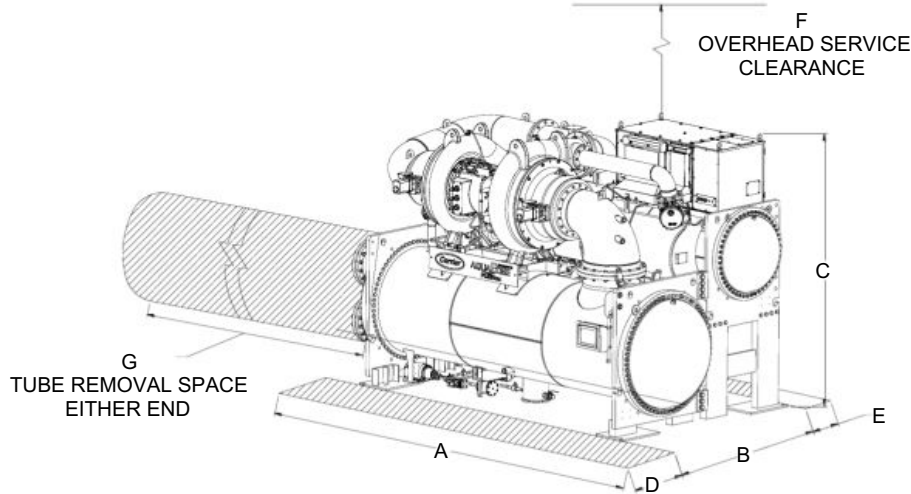

**NOTES:**

1. Dished head waterbox shown.
2. Service areas shown are minimum space required. For major compressor service, it is desirable to have an 2.4m wide service area on the cooler or condenser side to allow the compressor to be positioned on the floor next to the chiller, unless arrangements are made that allow for rigging the compressor elsewhere.
3. Refer to Table 1 for A, B and C.

**Table 1-1— 19DV Chiller Dimensions (Nozzle-In-Head Waterbox)**

19DV Dimensions (Nozzle-In-Head Waterbox)					
Cooler heat exchanger size	Condenser haet exchanger size	A (length, dished head waterbox)		B (width)	C (height)
		2-Pass			
		mm			
F2*	F2*	4595		2478	2827
F4*	F4*	5116		2478	2827
G2*	G2*	4779		2596	3055
G4*	G4*	5299		2596	3055
H2*	H2*	4619		2793	3229
H4*	H4*	5140		2793	3229

\*Assumes both cooler and condenser nozzle on same end of chiller.

**NOTES:**

1. Service access should be provided per American Society of Heating, Refrigerating, and Air-Conditioning Engineers (ASHRAE) 15, latest edition, National Fire Protection Association (NFPA) 70, and local safety code.
2. Overhead clearance for service rigging 19DV compressor should be at least 1524 mm.
3. Dimensions are approximate. Certified drawings available upon request.
4. Marine waterboxes typically add to the width of the machine. See certified drawings for details.
5. 'A' length dimensions shown are for standard 1034kPa design and flanges connections. The 2068kPa design and flanges will add length. See certified drawings.
6. Table contains heat exchanger dimensions. For arrangements where the compressor motor housing extends past the waterbox, consult the 19DV certified drawings.
7. Consult factory for configurations not listed in the above table.





## DIMENSIONS/CLEARANCE

Table 1-2— 19DV Chiller Dimensions (Marine Waterbox)

19DV Dimensions (Marine Waterbox)					
Cooler heat exchanger size	Condenser heat exchanger size	A (length, dished head waterbox)		B (width)	C (height)
		2-Pass			
		mm			
G2*	G2*	5344		2596	2928
G4*	G4*	5864		2596	2928
H2*	H2*	5549		2832	3229
H4*	H4*	6070		2832	3229

\*Assumes both cooler and condenser nozzle on same end of chiller.

**NOTES:**

1. Service access should be provided per American Society of Heating, Refrigerating, and Air-Conditioning Engineers (ASHRAE) 15, latest edition, National Fire Protection Association (NFPA) 70, and local safety code.
2. Overhead clearance for service rigging 19DV compressor should be at least 1524 mm.
3. Dimensions are approximate. Certified drawings available upon request.
4. 'A' length dimensions shown are for standard 1034kPa design and flanges connections. The 2068kPa design and flanges will add length. See certified drawings.
5. Table contains heat exchanger dimensions. For arrangements where the compressor motor housing extends past the waterbox, consult the 19DV certified drawings.
6. Consult factory for configurations not listed in the above table.

## PHYSICAL DATA

### Air-conditioning (380V-3Ph-50Hz)

Model	Cooling Capacity	Input Power	Chiller Line Amps	Footprint		
				Length	Width	Height
	kW	kW	A	mm	mm	mm
19DV-F24F243345B9	1300	199,6	302	4600	2480	2570
19DV-F24F243545D9	1650	256,9	388	4600	2480	2570
19DV-F24F243645F9	2000	319,1	482	4600	2480	2570
19DV-G24G234425B9	2110	321,2	523	4762	2508	2882
19DV-G24G244525D9	2462	377,9	616	4762	2508	2882
19DV-G44G444625D9	2813	434,8	688	5284	2508	2882

**Note:**

1. The above selections are based on entering/leaving chilled water temperature 12/7°C, entering/leaving cooling water temperature 32/37°C, evaporator fouling factor 0.0176 m<sup>2</sup>C/kW and condenser fouling factor 0.044 m<sup>2</sup>C/kW.
2. Carrier will select specific models using E-Cat on different requests for tonnage, lift, and efficiency. For details, please contact local agencies.
3. Standard evaporator and condenser water side pressure is 1.0MPa. For more requirements, please contact local agencies.
4. For more details or customized selections, please contact local agencies.



## SINGLE-STAGE CENTRIFUGAL LIQUID CHILLERS



- Single-stage compressor
- Industry-leading Efficiency with VFD
- Standard or high-tier VFD on choice
- Wide Application
- Stable Operation
- Low Sound Level
- Modular Construction

## 19XR/XRV Single-stage



Nominal cooling capacity 1000-3000 kW

The Carrier 19XR/19XRV centrifugal chillers provide exceptional value by achieving energy efficiency levels as high as 6.8 (COP<sub>r</sub>) utilising proven technology designed specifically for chlorine-free refrigerants:

- Unique concept of the hermetic compressor:
  - Single-stage aerodynamic impeller
  - Tunnel diffusers, based on aircraft engine technology
  - Motor cooled by refrigerant gas injection
- Possibility to control the compressors using a variable frequency drive (19XRV) to maximise machine energy efficiency.
- Use of high-efficiency evaporator and condenser tubes
- Expansion sub-cooler integrated into the condenser
- Patented float valve technology for optimised sub-cooling and refrigerant level in the evaporator
- Refrigerant R-134a or R-513A

These advantages, together with the modularity of the units and their efficiency, economical operation and dimensional constraints allow the use of the Carrier 19XR/19XRV centrifugal chillers in any high-capacity water cooling applications.

## PHYSICAL DATA

heat exchanger frame size	Compressor frame size	Dimensions (mm)					
		Length		Width		Height	
		Min	Max	Min	Max	Min	Max
3	XR3	4230	4820	1670	1800	2055	2465
4	XR3	4365	4950	1880	1880	2140	2550
5	XR3	4390	4980	1995	1995	2150	2720

heat exchanger frame size	Compressor frame size	Weight (kg)					
		net (chiller + R134a)		operating (net + water)		R134a	
		Min	Max	Min	Max	Min	Max
3	XR3	6780	8100	7200	8700	277	390
4	XR3	7180	9180	7985	10200	381	508
5	XR3	8090	10890	9145	12160	493	674

Data for unit with two-pass nozzle-in-head water boxes being at the same end (compressor end / DS code)

## FEATURES AND ADVANTAGES

- Nominal cooling capacities from 1000 to 3000 kW.
- Mix-match capabilities – a complete line of compressors and heat exchangers to ensure the optimal combination of machine components regardless of capacity, lift and efficiency specifications.
- Hermetic compressor – elimination of leak risks from the compressor/motor shaft sealing in an open compressor.
- Single-stage compressor with special features – aerodynamically contoured impellers, variable inlet guide vanes and movable diffusers for better compressor part and full-load operating efficiency.
- Variable speed compressor capability – improvement of part load efficiency and electrical performance.
- Heat exchangers certified by the European pressure vessels code (PED), and all marine code certifications.
- International Chiller Visual Control (ICVC) -a large english LCD (liquid crystal display) features 4 menu-specific soft keys. The default display offers all in one glance review of key chiller operation data, simplifying the interaction between chiller and user.

## OPTIONS/ACCESSORIES

- Two types of unit-mounted variable frequency drives (VFDs): standard and high tier, to match different customer requirements in terms of cost and electrical performances
- Refrigerant isolation valves allow the refrigerant to be stored inside the chiller during service
- Hot gas by-pass for surge prevention during operation at high condensing temperature or for optimized operation at low load conditions
- Spring isolators adapted for all chiller configurations
- Unit-mounted starter reduces machine installation time and expense
- High-voltage motors available: 3000 V, 3300V, 5500V, 6300V, 10 kV, 11 kV, 50 Hz or 60 Hz
- CCN/JBus or CCN/BACnet: remote connection
- 21 bar water heat exchanger
- Waterbox with flanges and counterflanges
- Delivered in multiple sections to facilitate the installation
- Refrigerant leak detector module : unit-mounted sensor (not compatible with 19XRV VFD)
- Tailor maid request Marine, Oil & Gas, Chemical, other customization

## OPTIONS/ACCESSORIES

### 19XR refrigeration cycle

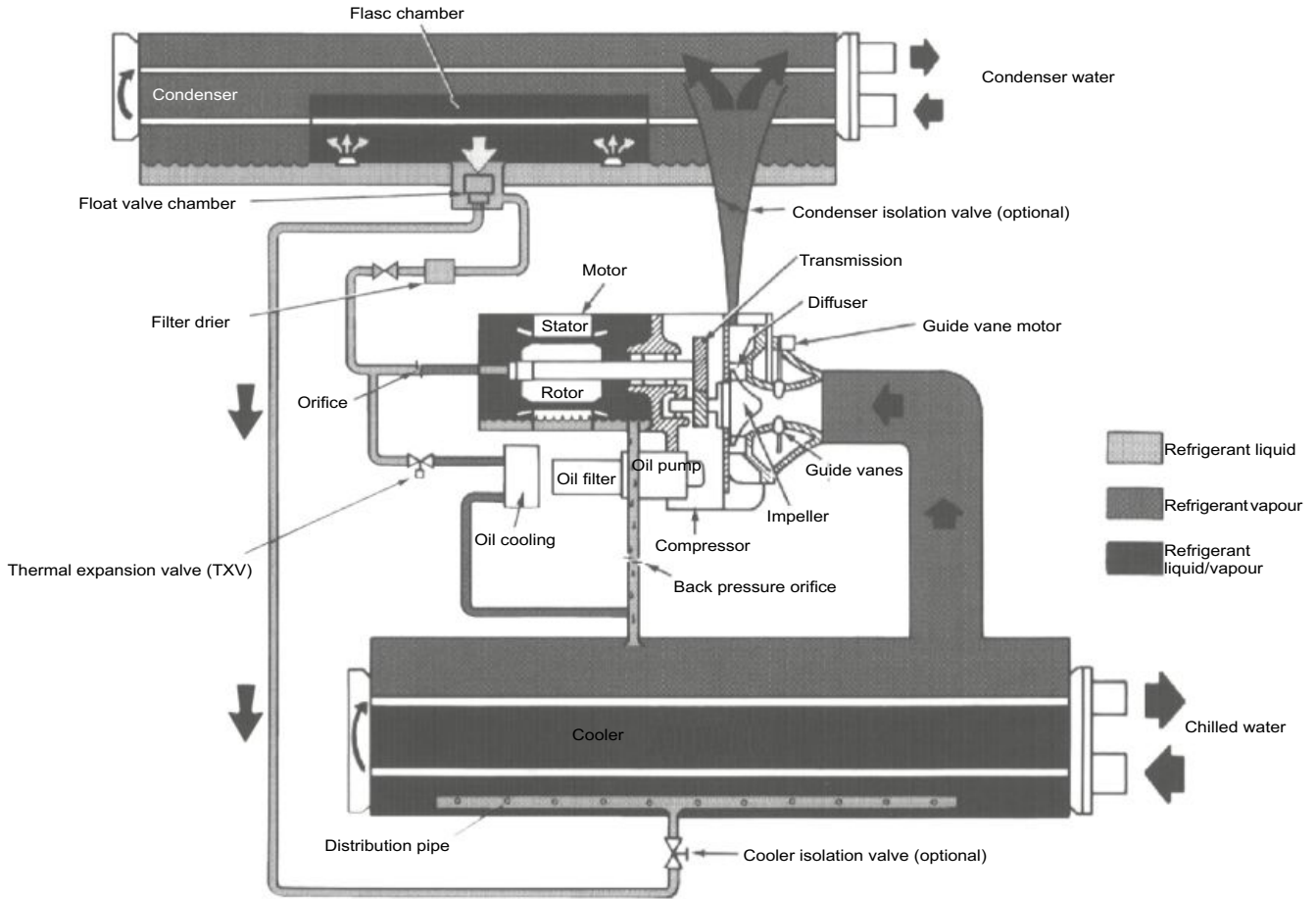

## CONTROLS

Touch Pilot control system with strong control and monitoring function during chiller operation. The Touch Pilot control system applies a 10.5 inch high resolution touch screen, which can support more than ten language choices for customer, real time display of operation parameters with pictures makes it more human friendly and comfortable interface for operation.







## TWO-STAGE CENTRIFUGAL LIQUID CHILLERS



- Interstage economizer
- Two-stage compressor
- Industry-leading Efficiency with VFD
- Wide Application
- Stable Operation
- Low Sound Level
- Modular Construction

# 19XR/XRV Two-stage



Nominal cooling capacity 2800 - 10500 kW

The Carrier 19XR/19XRV with a COP up to 6.5 (AHRI conditions) and an IPLV up to 7.4 or up to 10.5 with VFD centrifugal chillers provide exceptional value by achieving energy efficiency levels as high as 6.8 (COPr) utilising proven technology designed specifically for chlorine-free refrigerants:

- Interstage economizer to improve efficiency and increase capacity.
- Unique concept of the hermetic compressor:
  - Dual-stage aerodynamic impeller
  - Vane-less diffuser to meet high lift application requirement with stable operation
  - Motor cooled by spraying liquid refrigerant on the motor windings.
- Possibility to control the compressors using a variable frequency drive (19XRV) to maximise machine energy efficiency.
- Use of high-efficiency evaporator and condenser tubes
- Expansion sub-cooler integrated into the condenser
- Patented float valve technology for optimised sub-cooling and refrigerant level in the evaporator
- Refrigerant R-134a or R-513A

These advantages, together with the modularity of the units and their efficiency, economical operation and dimensional constraints allow the use of the Carrier 19XR/19XRV two-stage centrifugal chillers in any high-capacity water cooling applications such as air-conditioning, heat-pump, energy recovery, ice thermal storage, marine, VFD and high-voltage applications.



PHYSICAL DATA

Heat exchanger frame size	Compressor frame size	Dimensions (mm)					
		Length		Width		Height	
		Min	Max	Min	Max	Min	Max
7	XRE	5160	5210	2470	2935	3015	3283
8	XRE	5200	5845	2710	3165	3040	3335

Heat exchanger frame size	Compressor frame size	Weight (kg)					
		net		operating		R134a	
		Min	Max	Min	Max	Min	Max
7	XRE	16015	20815	17920	23155	836	1168
8	XRE	18505	24270	21195	27340	984	1309

heat exchanger frame size			Dimensions (mm)		
cooler frame size	condenser frame size	Compressor frame size	Length	Width	Height
A4	A4	XR6	5175	3130	3485
A6	A6	XR6	5785	3130	3485
A4	B4	XR6	5195	3255	3485
A6	B6	XR6	5805	3255	3485
B6	C6	XR7	5925	3670	3745
C6	C6	XR7	5975	3800	3815
C6	D6	XR7	5975	4015	3815

heat exchanger frame size			Weight (kg)		
cooler frame size	condenser frame size	Compressor frame size	net	operating	R134a
			Max	Max	Max
A4	A4	XR6	30830	35466	1277
A6	A6	XR6	32330	37580	1465
A4	B4	XR6	33080	38432	1416
A6	B6	XR6	34900	40813	1623
B6	C6	XR7	44270	52132	1709
C6	C6	XR7	49110	58055	1997
C6	D6	XR7	54190	64647	2218

Data for unit with two-pass nozzle-in-head water boxes being at the same end (compressor end / DS code)

## FEATURES AND ADVANTAGES

- Nominal cooling capacities from 2800-10500 kW.
- Mix-match capabilities – a complete line of compressors and heat exchangers to ensure the optimal combination of machine components regardless of capacity, lift and efficiency specifications.
- Hermetic compressor – elimination of leak risks from the compressor/motor shaft sealing in an open compressor.
- Dual stage compressor with non-blade diffuser designed, combined with inner-stage economizer for chiller performance improvement and high lift application. The innovative two-stage compressor provides a dramatic range of capabilities. With a maximum LWT of 65°C and a minimum LCWT of -6°C, the 19XR two-stage centrifugal chiller is ideal wherever energy conservation and environmental protection are required.
- Variable speed compressor capability on 19XRV-E AquaEdge chiller - Improvement of part load efficiency and electrical performance.
- 19XRV/XR(V)-E equipped with a LF2 VFD that designs with total harmonic distortion (THD)<5% and fully meets IEEE519-1992 requirement. The 19XRV/XR(V)-E becomes a more cost-effective choice for installations with a high percentage of time operating at part load.
- Heat exchangers certified by the European pressure vessels code (PED), and all marine code certifications.
- Touch Pilot control system with strong control and monitoring function during chiller operation. The Touch Pilot control system applies a 10.5 inch high resolution touch screen, which can support more than ten language choices for customer, real time display of operation parameters with pictures makes it more human friendly and comfortable interface for operation.



## OPTIONS/ACCESSORIES

- Two types of unit-mounted variable frequency drives (VFDs): standard and high tier, to match different customer requirements in terms of cost and electrical performances (VFD available on 19XRE only)
- Refrigerant isolation valves allow the refrigerant to be stored inside the chiller during service
- Hot gas by-pass for surge prevention during operation at high condensing temperature or for optimized operation at low load conditions
- Spring isolators adapted for all chiller configurations
- Unit-mounted starter reduces machine installation time and expense (VFD available on 19XRE only)
- High-voltage motors available: 400V (19XRE only), 3kV, 3.3kV, 6.3kV, 10kV, 11kV
- CCN/JBus or CCN/BACnet: remote connection
- 21 bar water heat exchanger
- Waterbox with flanges and counterflanges
- Nozzle with flanges (water inlet/outlet with flanges)
- Delivered in multiple sections sections to facilitate the installation
- Refrigerant leak detector module : unit-mounted sensor (not compatible with 19XRE with unit-mounted VFD)







## SINGLE-EFFECT STEAM-FIRED ABSORPTION CHILLERS SUPER ABSORPTION



Complete range  
350 to 2500 kW

HFC-refrigerant free

Steam supply pressure  
50 to 100 kPa

# 16TJ

Nominal cooling capacity 350-2500 kW

The Carrier Corporation has more than 100 years experience in providing HVAC systems and equipment around the world and offers a complete product solutions for many different type of applications: From residential to industrial.

For all cases where power grid is not available on site or either not extensively developed, or where thermal energy sources (water or steam) are available on site, Carrier offers a complete range of absorption chillers.

## PHYSICAL DATA

### Single effect steam-fired absorption chillers

16TJ		11	12	13	14	21	22	23	24
<b>Cooling capacity</b>	kW	352	422	527	633	738	844	985	1125
<b>Chilled water system*</b>									
Flow rate	l/s	15.1	18.2	22.7	27.3	31.7	36.4	42.5	48.3
Pressure drops	kPa	50	51	64	67	60	64	42	45
Connection (ANSI)	in	4	4	4	4	5	5	6	6
Retention volume	m <sup>3</sup>	0.12	0.13	0.15	0.17	0.22	0.25	0.29	0.31
<b>Cooling water system*</b>									
Flow rate	l/s	22.7	27.3	34.2	40.8	47.8	54.4	63.6	72.8
Pressure drops	kPa	34	37	32	36	32	35	65	70
Connection (ANSI)	in	5	5	5	5	6	6	8	8
Retention volume	m <sup>3</sup>	0.33	0.37	0.41	0.45	0.58	0.63	0.69	0.76
<b>Steam system</b>									
Consumption	kg/h	780	940	1170	1410	1640	1880	2190	2500
Steam inlet (ANSI)	in	5	5	5	5	6	6	8	8
Drain outlet (ANSI)	in	1-1/2	1-1/2	1-1/2	1-1/2	1-1/2	1-1/2	1-1/2	1-1/2
Control valve	in	2	2	2-1/2	2-1/2	2-1/2	3	3	4
Shutoff valve	in	2	2	2-1/2	2-1/2	2-1/2	3	3	4
<b>Dimensions</b>									
Length	mm	2690	2690	3690	3690	3790	3790	4850	4850
Height	mm	2200	2200	2200	2200	2350	2350	2370	2370
Width	mm	1400	1400	1400	1400	1560	1560	1560	1560
Tube removal space	mm	2400	2400	3400	3400	3400	3400	4500	4500
<b>Weight</b>									
Operating weight	kg	4000	4300	5100	5400	6700	6900	7900	8300
Max shipping weight**	kg	3500	3700	4500	4700	5800	6000	6900	7200
<b>Power supply</b>	V-ph-Hz	400-3-50							
Apparent power	kVA	4.0	4.0	4.0	4.0	5.8	5.8	5.9	5.9
Total electric current	A	6.1	6.1	6.1	6.1	8.8	8.8	8.9	8.9
Absorbent pump, power input	kW	1.1	1.1	1.1	1.1	2.2	2.2	2.2	2.2
Absorbent pump, electric current	A	2.8	2.8	2.8	2.8	5.5	5.5	5.5	5.5
Refrigerant pump, power input	kW	0.2	0.2	0.2	0.2	0.2	0.2	0.3	0.3
Refrigerant pump, electric current	A	1.3	1.3	1.3	1.3	1.3	1.3	1.4	1.4
Purge pump, power input	kW	0.4	0.4	0.4	0.4	0.4	0.4	0.4	0.4
Purge pump, electric current	A	1.1	1.1	1.1	1.1	1.1	1.1	1.1	1.1
PD cell heater	kW	0.038	0.038	0.038	0.038	0.038	0.038	0.038	0.038
Control circuit	kW	0.3	0.3	0.3	0.3	0.3	0.3	0.3	0.3

\* In accordance with ARI 560 - 2000  
12.2 / 6.7 °C (fouling factor = 0.0176 m<sup>2</sup> K/kW)  
29.4 / 38.4 °C (fouling factor = 0.044 m<sup>2</sup> K/kW)  
Saturated steam 100 kPa

\*\* All sizes shipped as one-piece

Notes: These performance data are provided to support early design activity. For selection outside ARI operating conditions contact Carrier.

## PHYSICAL DATA

16TJ		31	32	41	42	51	52	53
<b>Cooling capacity</b>	kW	1266	1407	1582	1758	1969	2215	2461
<b>Chilled water system*</b>								
Flow rate	l/s	54.4	60.6	68.1	75.8	84.7	95.3	106.1
Pressure drops	kPa	48	51	44	39	35	47	61
Connection (ANSI)	in	6	6	8	8	8	8	8
Retention volume	m <sup>3</sup>	0.35	0.38	0.49	0.56	0.7	0.77	0.83
<b>Cooling water system*</b>								
Flow rate	l/s	81.7	90.8	102.2	113.6	127.2	143.1	158.9
Pressure drops	kPa	54	57	59	63	39	52	68
Connection (ANSI)	in	8	8	10	10	12	12	12
Retention volume	m <sup>3</sup>	0.98	1.05	1.31	1.41	1.98	2.13	2.28
<b>Steam system</b>								
Consumption	kg/h	2810	3120	3510	3900	4370	4920	5460
Steam inlet (ANSI)	in	8	8	8	8	10	10	10
Drain outlet (ANSI)	in	2	2	2-1/2	2-1/2	2-1/2	2-1/2	2-1/2
Control valve	in	4	4	4	4	4	5	5
Shutoff valve	in	4	4	4	4	4	5	5
<b>Dimensions</b>								
Length	mm	4940	4940	4990	4990	5060	5600	6100
Height	mm	2610	2610	2860	2860	3210	3210	3210
Width	mm	1630	1630	1700	1700	1990	1990	1990
Tube removal space	mm	4500	4500	4500	4500	4600	5200	5700
<b>Weight</b>								
Operating weight	kg	10300	10600	12500	12800	17500	18900	20200
Max shipping weight**	kg	8900	9100	10700	10900	14800	16000	17100
<b>Power supply</b>	V-ph-Hz	400-3-50						
Apparent power	kVA	7.3	7.3	7.3	7.3	7.3	7.3	7.3
Total electric current	A	10.9	10.9	10.9	10.9	10.9	10.9	10.9
Absorbent pump, power input	kW	3	3	3	3	3	3	3
Absorbent pump, electric current	A	7.5	7.5	7.5	7.5	7.5	7.5	7.5
Refrigerant pump, power input	kW	0.3	0.3	0.3	0.3	0.3	0.3	0.3
Refrigerant pump, electric current	A	1.4	1.4	1.4	1.4	1.4	1.4	1.4
Purge pump, power input	kW	0.4	0.4	0.4	0.4	0.4	0.4	0.4
Purge pump, electric current	A	1.1	1.1	1.1	1.1	1.1	1.1	1.1
PD cell heater	kW	0.038	0.038	0.038	0.038	0.038	0.038	0.038
Control circuit	kW	0.3	0.3	0.3	0.3	0.3	0.3	0.3

\* In accordance with ARI 560 - 2000  
12.2 / 6.7 °C (fouling factor = 0.0176 m<sup>2</sup> K/kW)  
29.4 / 38.4°C (fouling factor = 0.044 m<sup>2</sup> K/kW)  
Saturated steam 100 kPa

\*\* All sizes shipped as one-piece

Notes: These performance data are provided to support early design activity. For selection outside ARI operating conditions contact Carrier.

## NOMENCLATURE

16TJ - 11

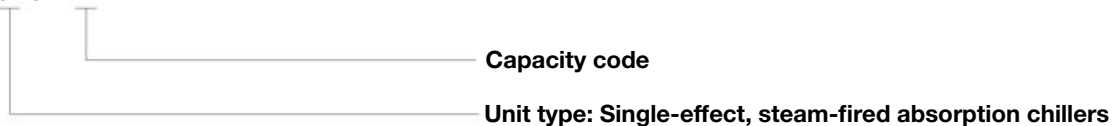

## COMPONENT IDENTIFICATION

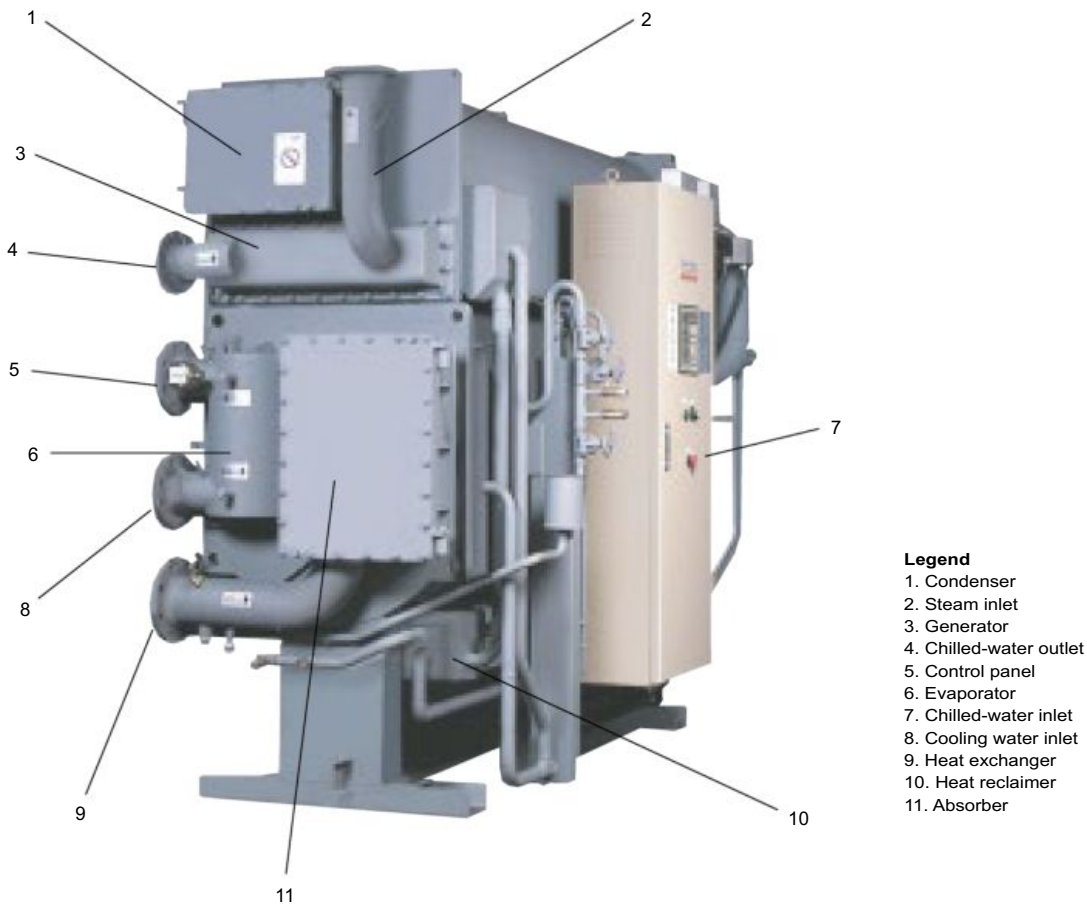

### Legend

1. Condenser
2. Steam inlet
3. Generator
4. Chilled-water outlet
5. Control panel
6. Evaporator
7. Chilled-water inlet
8. Cooling water inlet
9. Heat exchanger
10. Heat reclaimer
11. Absorber

## SCOPE OF SUPPLY

### 1. Standards met

The units comply with the following standards:

- ARI 560-2000
- 2006/42/EC (machine directive)
- 2006/95/EC (low-voltage directive)
- 2004/108/EC (electromagnetic compatibility directive)
- 97/23/EC (pressure equipment directive).

### 2. Absorption chiller, comprising:

1. Lower shell
  - Evaporator and refrigerant dispersion tray
  - Absorber and absorbent dispersion tray with eliminators
  - Bases.
2. Upper shell
  - Generator with eliminators
  - Condenser with eliminators
  - Rupture disk.
3. Heat exchangers with refrigerant drain heat reclaimer
4. Pumps
  - Absorbent pump with isolating valves
  - Refrigerant pump with isolating valves
  - Purge pump.
5. Purge unit
  - Purge tank with ejector device
  - Diaphragm valves and piping with liquid trap
  - Pressure sensor
  - Palladium cell with heater.

6. Control panel
  - Controller with data display
  - LEDs and operation buttons
  - Inverter for absorbent pump (option)
  - Circuit breaker
  - Transformer
  - Relays and terminal blocks
  - Purge pump operation switch.
7. Locally mounted parts
  - Temperature sensors
  - Chilled-water flow switch.
8. Interconnecting piping and wiring
  - Refrigerant and absorbent piping
  - Internal power and control wiring.
9. Initial charge
  - Absorbent (lithium bromide)
  - Refrigerant (water)
  - Inhibitor (lithium molybdate).
10. Painting
  - Main unit: Rust-preventive paint
  - Control panel: Finish paint.
11. Accessories
  - Operation manual
  - Washer (for fixing foundation bolts)
  - Gasket and sealant for rupture disk
  - Purge pump oil
  - Matching flanges, gaskets, bolts and nuts.

## SCOPE OF SUPPLY

### 3. Factory test

1. Check of external dimensions
2. Hydraulic pressure test of water headers Test pressure is 1.5 times of maximum working pressure
3. Vacuum-side leak test
4. Electric insulation resistance test
5. Dielectric breakdown test
6. Function test of electric circuit and safety devices

### 4. Scope of supply of the purchaser

1. Building and foundations
2. External chilled water, cooling water and steam piping work including various safety valves, isolation valves, mating flanges, gaskets, bolts and nuts, etc.
3. External wiring and piping for the chillers including necessary parts
4. Insulation for the chillers including necessary parts.

5. Finish painting of the chillers (if needed)
6. Cooling water entering temperature control device
7. Cooling water treatment device
8. Various temperature/pressure gauges for steam and water lines.
9. Cooling tower(s), chilled-water pump(s) and steam control valve and steam shut-off valve
10. Electric power supply (as specified)
11. Supply of chilled water, cooling water, steam and air\* at rated conditions
12. Maintenance of the chiller
13. Necessary tools, labour and materials for installation and site test operation
14. Any other item not specifically mentioned in the scope of supply

\* If pneumatic steam valve control is used.

## SCOPE OF ORDER

Item	Standard	Option
<b>Chilled water</b>		
Temperature	Entering: 12.2 °C, leaving: 5 °C through 12 °C Leaving: 6.7 °C, temperature difference 3 K through 10 K	
Flow rate	0.043 l/s x kW - Changes depending on chilled water temperature difference (min 50%)	
Max. working pressure	1034 kPa	1540 kPa, 2068 kPa
Hydraulic test pressure	Max. working pressure x 1.5	Max working pressure x 1.5
Fouling factor	0.018 m <sup>2</sup> K/kW Max. 0.18 m <sup>2</sup> K/kW	
Tube material	Copper tube	Cu Ni tube
Water quality	Refer to JRA-GL02E-1994	No option
Structure of water header	Removable type and epoxy treated	No option
Manufacturing standard of water header	Flanged ANSI	No option
<b>Cooling water</b>		
Temperature	Entering: 29.4 °C Leaving: 38.4 °C, entering: 20 °C through 33 °C	
Flow rate	0.065 l/s per kW. Within the water flow rate range of each model	
Max. working pressure	1034 kPa	1540 kPa, 2068 kPa
Hydraulic test pressure	Max. working pressure x 1.5	
Fouling factor	0.044 m <sup>2</sup> K/kW. Max. 0.18 m <sup>2</sup> K/kW	
Tube material	Copper tube	Cu Ni tube
Water quality	Refer to JRA-GL02E-1994	No option
Structure of water header	Hinged type and epoxy treated	No option
Manufacturing standard of water header	Flanges ANSI	No option
<b>Steam</b>		
Supply pressure	100 kPa, 50 kPa through 100 kPa, max. 5 K superheat	
Specific steam consumption	2.22 kg/h/kW. Changes depend on the specifications.	
Max. working pressure	146 kPa	No option
Hydraulic test pressure	Max. working pressure x 1.5	No option
Tube material	9/1 Copper nickel tube	No option
Steam quality	Refer to JIS-B-8223	No option
Manufacturing standard of water header	Flanged ANSI	No option
<b>Electricity</b>		
Power supply	400 V - 3 phase - 50Hz (Voltage control within ±10%, frequency control within ±5%)	Contact the Carrier representative
<b>Shipment</b>		
	One section	Multi-shipment



## SCOPE OF ORDER

Item	Standard	Option
<b>Control</b>		
Safety functions	Refrigerant temperature Chilled water freeze protection Chilled water flow switch Cooling water temperature HT generator temperature HT generator pressure HT generator solution level Crystallisation protection Motor protection	Cooling water flow switch
Capacity control	Digital PID control by chilled-water temperature	Inverter control of #1 absorbent pump
Parts	Selected by Carrier	No option
<b>Control panel</b>		
Painting	Munsell 5Y-7/1	No option
Indication lights	Operation Stop Alarm	No option No option No option
Display	LED	No option
External terminals (volt-free normally open contact)	Operation indication Stop indication Alarm indication Feedback indication Cooling mode indication	No option
Structure Parts	Indoor type Selected by Carrier	No option No option
<b>Electrical wiring and piping</b>	Wire: 600 V polyvinyl grade (chloride-insulated wires) Pipe: Plicatube (flexible metal conduits)	No option No option
<b>Insulation condition</b>		
Place Ambient temperature Ambient humidity	Indoor 5 °C through 40 °C Relative humidity: Max. 90 % at 45 °C	No option No option No option
Atmosphere	Be sure the following are not present: - Corrosive gas - Explosive gas - Poisonous gas	No option

## FEATURES AND ADVANTAGES

- The Carrier 16TJ single-effect absorption chillers are designed for cooling applications where low-pressure steam is available as waste heat.
- They can tie into district steam systems.
- Carrier absorption chillers allow diversification of critical cooling requirements. Critical cooling loads are met with minimal electrical power input.
- They allow smaller emergency generators compared to an electrical driven chiller.
- The units are ozone-safe and CFC-free. Cooling requirements are met without chlorine-based refrigerants.
- They reduce the contribution to global warming and minimise the global impact by greatly reducing electricity consumption and production of greenhouse gases.
- The solution inhibitor has no impact on the environment.
- An absorption chiller does not utilise mechanical moving parts, and this leads to quiet, vibration-free operation.
- The use of high-efficiency heat transfer surfaces has reduced the space required for installation of the absorption chiller, resulting in a smaller footprint.

## CONTROLS

### Expert self-diagnosis function

- The expert function is provided to monitor operating conditions, predict chiller information and maintain stable operation.

### Predictive maintenance information

**Graph 1 - Fouling of heat transfer tubes in cooling water system**

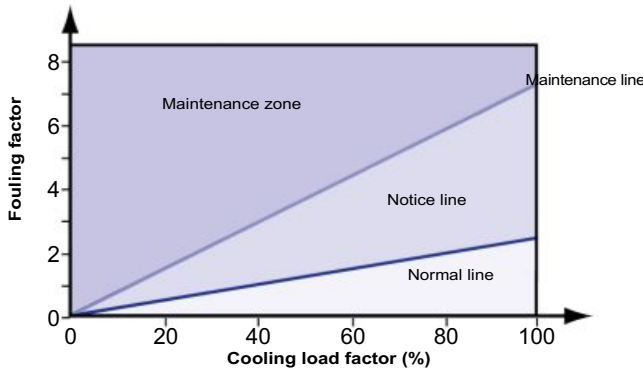

**Graph 2 - Trend of absorbent concentration**

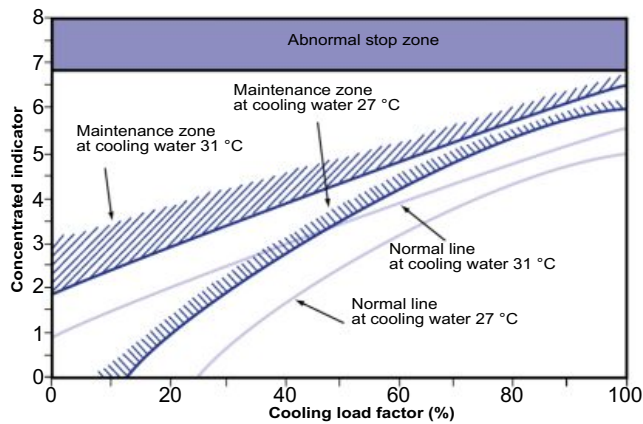

**Graph 3 - Vacuum condition monitoring**

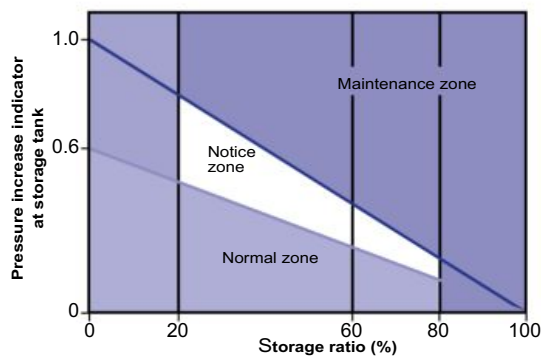

- Legend**
1. Storage tank
  2. Diluted solution
  3. Purge nozzle
  4. Pd cell
  5. Pressure sensor



### Carrier control system

- The Carrier control system surpasses other proportional only control systems available today. The digital PID (proportional plus integral plus derivative) control maximises unit performance by maintaining a  $\pm 0.5$  K variance in leaving chilled-water temperature from the set-point. Proportional controls can typically only maintain a  $\pm 1$  K variance from the set-point. The controller's innovative design also incorporates the ability to start and stop the system chilled and cooling water pumps. During shutdown these pumps are sequenced to ensure a complete dilution cycle.
- The leaving chilled-water temperature is measured every five seconds and steam input is changed according to the gradient of the leaving chilled-water temperature curve. System temperatures, set-points, and operational records are displayed along with indicator lights for the chiller and pumps.
- The Carrier control system offers its users selfdiagnostics by constantly monitoring the chiller status and will automatically shut the chiller down if a fault occurs. The cause of shutdown will be retained in the memory and can be displayed for immediate operator review. The controller's memory will also retain and display the cause of the last three system fault conditions. This method of retaining fault conditions is extremely useful for maintaining an accurate record of unit performance and fault history.

### Display and control board

**Figure 2 - Indication lights**

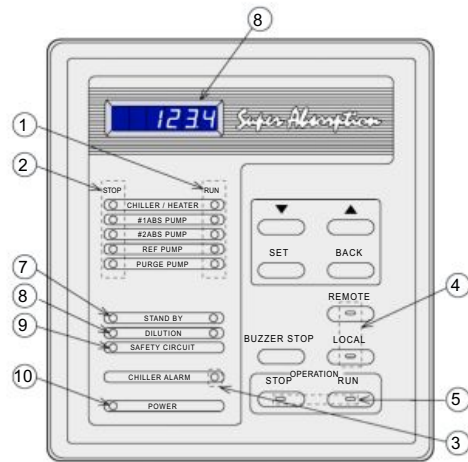

**Legend Name**

1. Operation indication light
2. Stop indication light
3. Alarm indication light
4. Remote/local select button with LED
5. Operation select button with LED
6. Data display
7. Stand-by indication light
8. Dilution indication light
9. Safety circuit indication light
10. Power indication light
- GL. Purge indication light
- 43P. Purge pump on-off switch
- 43ES. Emergency stop switch

**LED colour**

- Green
- Orange
- Red
- Green
- Green
- 7 segment LED (red)
- Green
- Green
- Green
- Orange
- Green

## CONTROLS

### Fast digital PID control

The introduction of new digital PID control stabilises the chilled water temperature with high accuracy. It quickly responds to the load fluctuation and supplies stable chilled water temperature. It is suitable for air-conditioning intelligent buildings which require sophisticated control.

### Saving energy with the inverter (option)

Balancing the load and flow rate with the absorbent pump's inverter control enables efficient and energy-saving operation. As a result, it reduces input energy and electric power consumption. Running cost is decreased by 5% compared to non-inverter control.

Graph 4 - Running cost curve

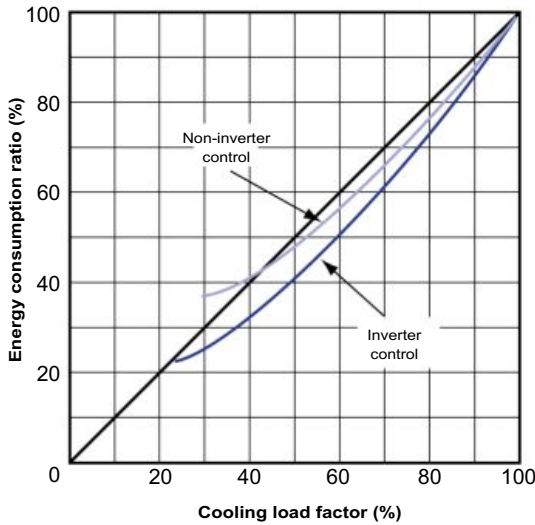

Notes:

1. Chilled-water leaving temperature 7 °C constant
2. Cooling water entering temperature:

Load factor (%)	Temperature (°C)
100	32
50	27
30	25

### Purge system

- The high-performance purge system maintains the required operating pressure, preserves chiller performance characteristics, minimises chiller maintenance to one purge operation per season (for year-round operation).

### Steam valve opening control

- At the start-up, the opening angle of the steam control valve is controlled in three stages, reducing the amount of steam and the time needed to reach the desired level, compared with the previous model.
- Adjusting the opening speed of the steam control valve at the second and third stage, it is possible to set up the most suitable conditions for the site auxiliary equipment.

Graph 5 - Steam valve opening control

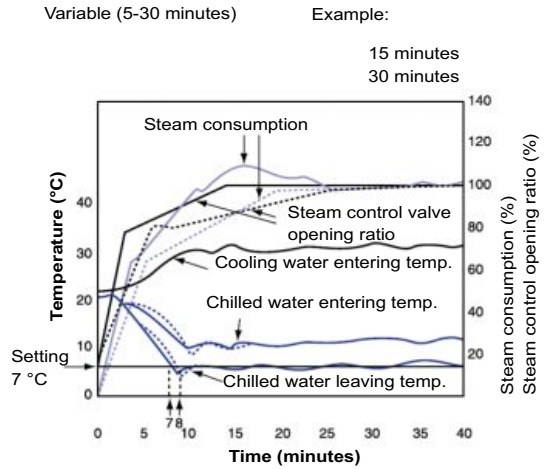

### Expansion of safe operating zone

- This ensures quick response to rapid changes and maintains stable operation.
- The safe operating zone is between 19 °C and 34 °C cooling water temperature (for a nominal cooling water entering temperature of 32 °C).

Graph 6 - Safe operating zone chart

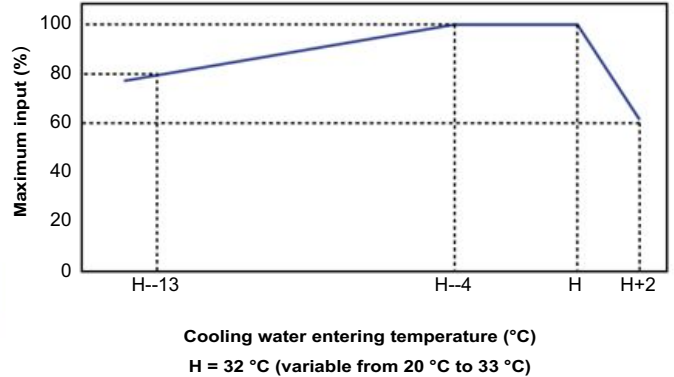

H = 32 °C (variable from 20 °C to 33 °C)

### Crystallisation protection

- A microprocessor monitors the absorbent concentration. Steam supply is stopped, and the unit is returned to normal operation, when the concentration is over a certain limit, to prevent the crystallisation of absorbent.

## FOUNDATION DIMENSIONS, MM

Figure 3 - 16TJ-11 through 16TJ-42

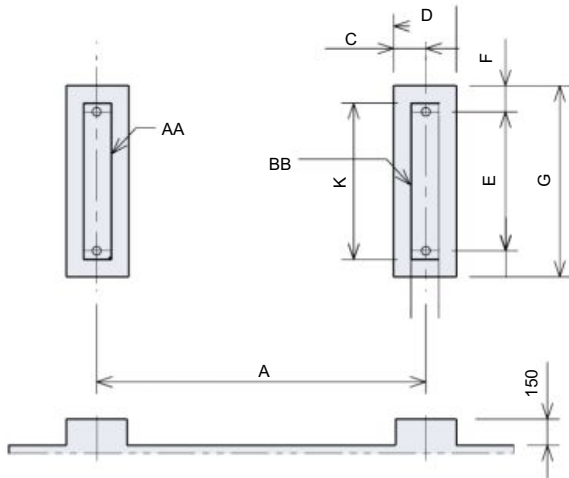

Figure 5 - 16TJ-51 through 16TJ-53

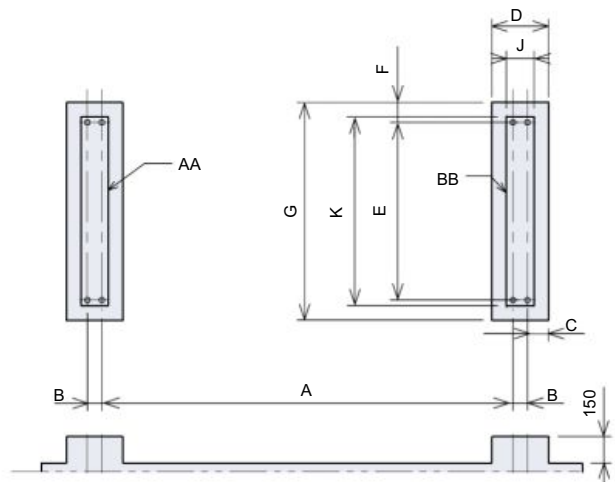
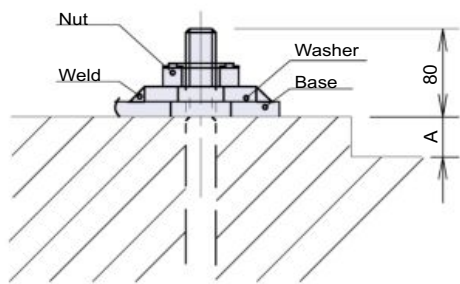

Figure 4 - Details of weld



A = 150 mm and more

**Notes:**

1. The machine base has  $\varnothing 50$ -mm hole for the anchor bolt.
2. The anchor bolt should be fixed as shown in the detail drawing. Washer should be welded to the base (see Fig. 4)
3. There should be a drain channel around the foundation.
4. The floor surface should be made waterproof to facilitate maintenance work.
5. The surface of the foundation should be made flat.
6. Anchor bolts and nuts are to be supplied by customer.

### Dimensional data

16TJ	Weight, kg			Dimensions, mm								
	AA + BB	AA	BB	A	B	C	D	E	F	G	J	K
11	3800	1900	1900	1890	--	175	360	800	150	1100	160	900
12	4000	2000	2000	1890	--	175	360	800	150	1100	160	900
13	4900	2450	2450	2916	--	175	360	800	150	1100	160	900
14	5100	2550	2550	2916	--	175	360	800	150	1100	160	900
21	6200	3100	3100	2866	--	200	400	1000	150	1300	200	1100
22	6500	3250	3250	2866	--	200	400	1000	150	1300	200	1100
23	7600	3800	3800	3886	--	200	400	1000	150	1300	200	1100
24	8000	4000	4000	3886	--	200	400	1000	150	1300	200	1100
31	9800	4900	4900	3836	--	225	450	1100	150	1400	250	1200
32	10200	5100	5100	3836	--	225	450	1100	150	1400	250	1200
41	11800	5900	5900	3836	--	225	450	1150	150	1450	250	1250
42	12300	6150	6150	3836	--	225	450	1150	150	1450	250	1250
51	16900	8450	8450	3706	130	190	510	1600	180	1960	250	1700
52	18300	9150	9150	4248	130	190	510	1600	180	1960	250	1700
53	19600	9800	9800	4746	130	190	510	1600	180	1960	250	1700







## SINGLE-EFFECT HOT WATER-FIRED ABSORPTION CHILLERS

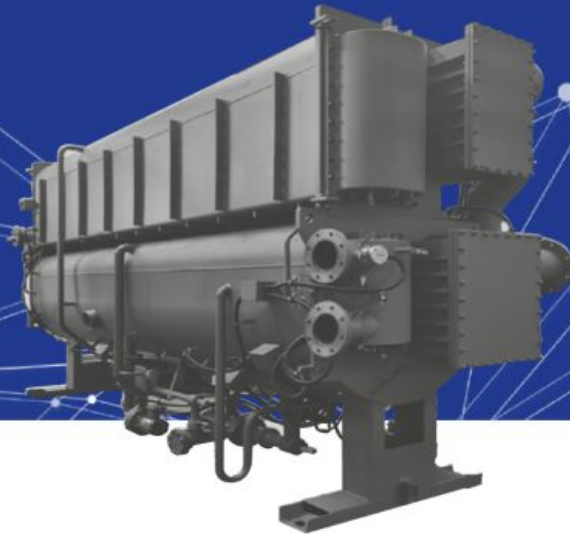

# 16LJ01-03 16LJ-F11- 83 NEW

Nominal cooling capacity 83-3956 kW

The Carrier Corporation has more than 100 years experience in providing HVAC systems and equipment around the world and offers a complete product solutions for many different type of applications: From residential to industrial.

For all cases where power grid is not available on site or either not extensively developed, or where thermal energy sources (water or steam) are available on site, Carrier offers a complete range of absorption chillers.



CARRIER participates in the ECP programme for LCP-HP  
Check ongoing validity of certificate:  
[www.eurovent-certification.com](http://www.eurovent-certification.com)

## FEATURES

- The Carrier 16LJ & 16LJ-F single-effect absorption chillers are designed to provide chilled water from waste heat sources generated from industrial processes and cogeneration systems.
- Carrier absorption chillers allow diversification of critical cooling requirements. Critical cooling loads are met with minimal electrical power input.
- They allow smaller emergency generators compared to an electrical driven chiller.
- The units are ozone-safe and CFC-free. Cooling requirements are met without chlorine-based refrigerants.
- They reduce the contribution to global warming and minimise the global impact by greatly reducing electricity consumption and production of greenhouse gases.
- The solution inhibitor has no impact on the environment.
- An absorption chiller does not utilise mechanical moving parts, and this leads to quiet, vibration-free operation.
- The use of high-efficiency heat transfer surface has reduced the space required for installation of the absorption chiller, resulting in a smaller footprint.

## NEW FEATURES OF 16LJ-F

### Enhanced durability by Stainless steel generator tubes

- New Carrier 16LJ-F single-effect hot water absorption chillers uses stainless steel tubes (SUS436L) for the generator in order to achieve enhanced durability.

### Falling film type generator

- Falling film type generator is applied for New Carrier 16LJ-F single-effect hot water absorption chiller and it reduces amount of Lithium bromide solution and it resulted in quick start-up and quick response for load changes.

### Touch screen

- Carrier New 16LJ-F single-effect hot water absorption chiller is equipped with 8.4 inch Touch screen for easy operation and monitoring.

Main screen



Flow chart screen

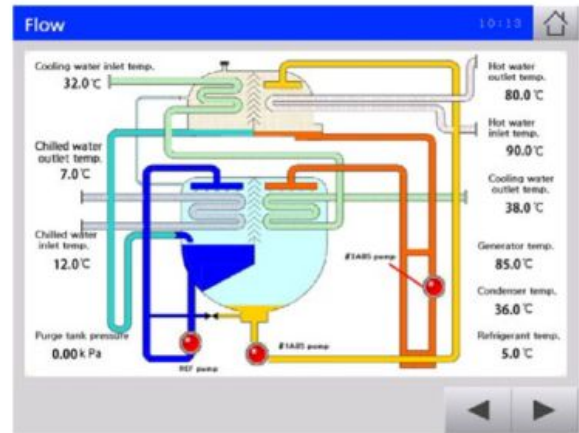

Trend screen



### Modbus communication

- New 16LJ-F has a capability to communication via Modbus protocol as standard. Communication via BACnet is also possible (optional).

## THE ABSORPTION CYCLE

The absorption cooling cycle, like the mechanical vapour compression refrigeration cycle, utilizes the latent heat of evaporation of a refrigerant to remove heat from the entering chilled water. Vapour compression refrigeration systems use a chlorine-based refrigerant and a compressor to transport the refrigerant vapour to be condensed in the condenser. The absorption cycle, however, uses water as the refrigerant and an absorbent lithium bromide solution to absorb the vaporised re-frigerant. Heat is then applied to the solution to release the re-frigerant vapour from the absorber. The refrigerant vapour is then condensed in the condenser.

The basic single-effect absorption cycle (see Figure 1) includes generator, condenser, evaporator and absorber with refrigerant (liquid) and lithium bromide as the working solutions. The generator utilizes a heat source (steam or hot water) to vaporise the diluted lithium bromide solution. The water vapour that is released travels to the condenser where it is condensed back into a liquid, transferring the heat to the cooling tower water. Once condensed, the liquid refrigerant is distributed over the evaporator tubes, removing the heat from the chilled water and vaporising the liquid refrigerant. The concentrated lithium bromide solution from the generator passes into the absorber, absorbs the refrigerant vapour solution from the evaporator and dilutes itself. The diluted lithium bromide solution is then pumped back to the generator where the cycle is started again.

Figure 1 - Simplified absorption cycle

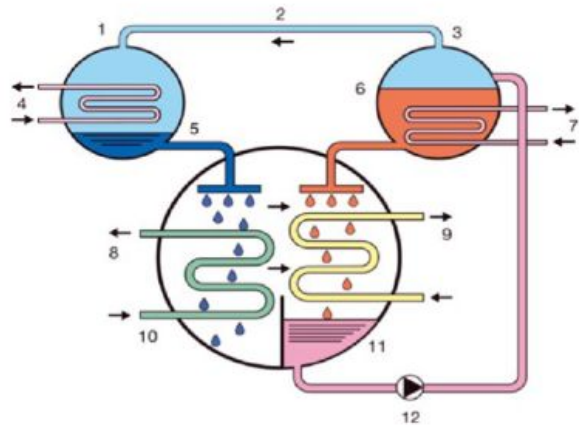

- Legend**
1. Condenser
  2. Refrigerant vapour
  3. Generator
  4. Cooling water
  5. Liquid refrigerant
  6. Concentrated solution
  7. Heat source
  8. Chilled water
  9. Cooling water
  10. Evaporator
  11. Absorber
  12. Absorbent pump

Figure 2 – Cooling cycle schematic  
16LJ - F 11 - 82

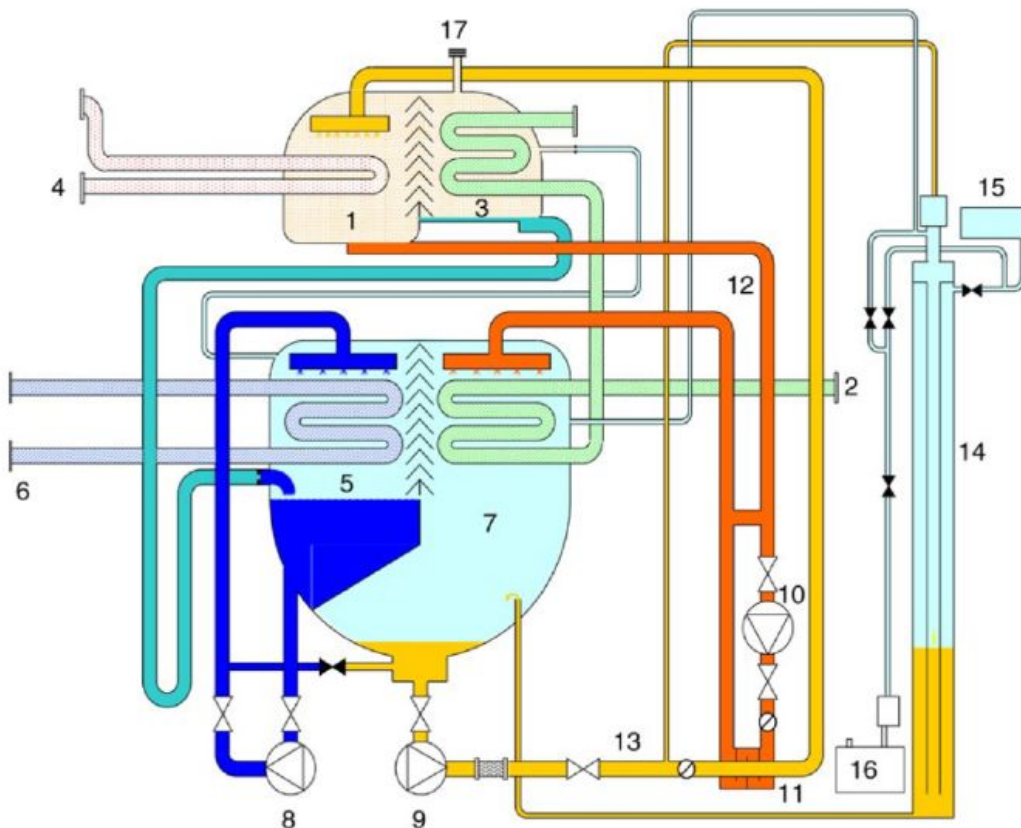

- Legend**
1. Generator
  2. Cooling water
  3. Condenser
  4. Hot water
  5. Evaporator
  6. Chilled water
  7. Absorber
  8. Refrigerant pump
  9. Absorbent pump No. 1
  10. Absorbent pump No. 2
  11. Heat exchanger
  12. Concentrated solution
  13. Diluted solution
  14. Purge unit
  15. Purge tank
  16. Purge pump
  17. Rupture disk

## CHILLER FEATURES

### Expert self-diagnosis function

- The expert function is provided to monitor operating conditions, predict chiller information and maintain stable operation.

### Predictive maintenance information

**Graph 1 - Fouling of heat transfer tubes in coolin water system**

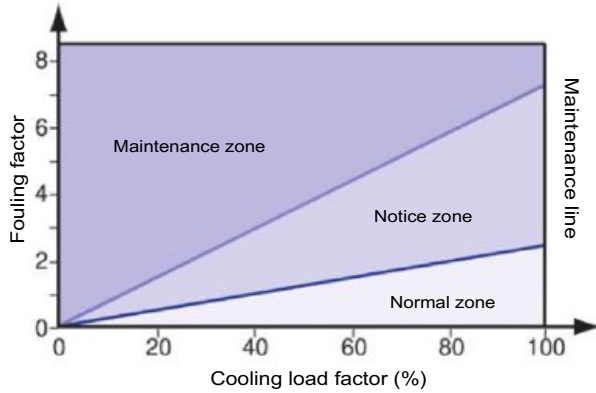

**Graph 2 - Vacuum condition monitoring**

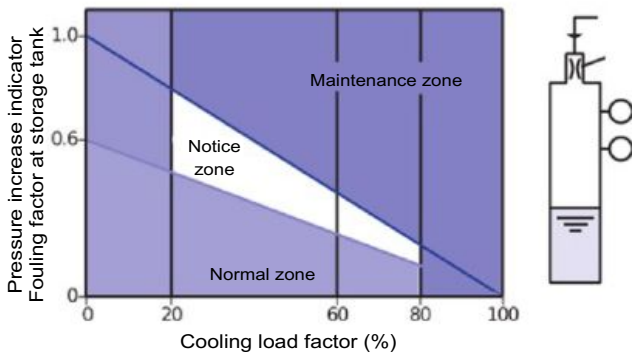

**Legend**

- Storage tank
- Diluted solution
- Purge nozzle
- Palladium cell
- Pressure sensor

### Control system

- The Carrier control system surpasses other proportional only control systems available today. The digital PID (proportional plus integral plus derivative) control maximises unit performance by maintaining a  $\pm 0.5$  K variance in leaving chilled-water temperature from the setpoint. Proportional controls can typically only maintain a  $\pm 1$  K variance from the setpoint. The controller's innovative design also incorporates the ability to start and stop the system chilled/hot and cooling water pumps. During shutdown these pumps are sequenced to ensure a complete dilution cycle.
- The leaving chilled-water temperature is measured every five seconds and steam input is changed according to the gradient of the leaving chilled-water temperature curve. System temperatures, setpoints, and operational records are displayed along with indicator lights for the chiller and pumps.
- The Carrier control system offers its users selfdiagnostics by constantly monitoring the chiller status and will automatically shut the chiller down if a fault occurs. The cause of shutdown will be retained in the memory and can be displayed for immediate operator review. The controller's memory will also retain and display the cause of the last three system fault conditions. This method of retaining fault conditions is extremely useful for maintaining an accurate record of unit performance and fault history.

### Touch Panel

**Figure 3 - Touch Panel Screen**

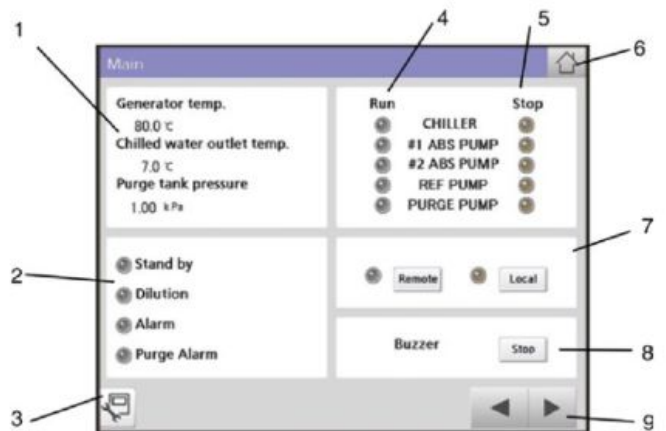

**Legend**

- Data display area
- Status display area
- Setting menu
- Operation indication lamp
- Stop indication lamp
- Main menu key
- Remote/local select key
- Alarm/Buzzer stop key
- Display switching key



## CHILLER FEATURES

### Fast digital PID control

The introduction of new digital PID control stabilises the chilled/hot water temperature with high accuracy. It quickly responds to the load fluctuation and supplies stable chilled/hot water temperature. It is suitable for air-conditioning intelligent buildings which require sophisticated control.

### Saving energy with the inverter (option)

Balancing the load and flow rate with the absorbent pump's inverter control enables efficient and energy-saving operation. As a result, it reduces input energy and electric power consumption. Running cost is decreased by 5% compared to non-inverter control.

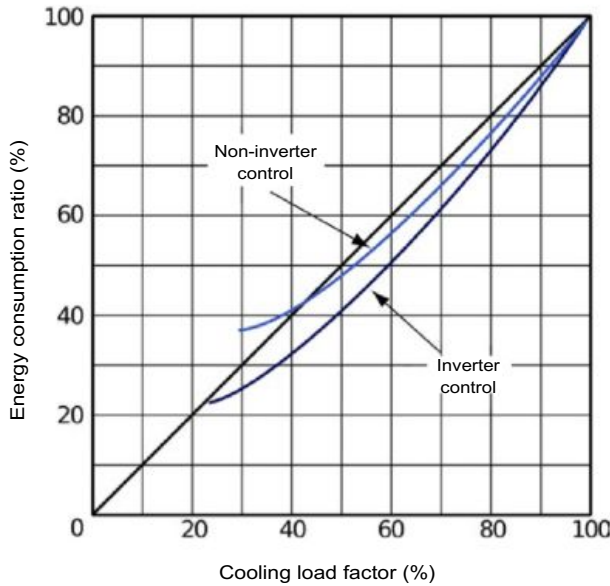

**Notes**

1. Chilled water leaving temperature : 7 °C constant
2. Cooling water entering temperature

Load factor (%)	Temperature ( °C )
100	32
50	27
30	25

### Purge system

- The high-performance purge system maintains the required operating pressure, preserves chiller performance characteristics, minimises chiller maintenance to one purge operation per season (for year-round operation).

### Hot water control valve

- At the start-up, the opening angle of the hot-water control valve is controlled in three stages, reducing the amount of hot water and the time needed to reach the desired level, compared with the previous model.
- Adjusting the opening speed of the hot-water control valve at the second and third stage, it is possible to set up the most suitable conditions for the site auxiliary equipment.

### Graph 4 - Hot water valve opening ratio control

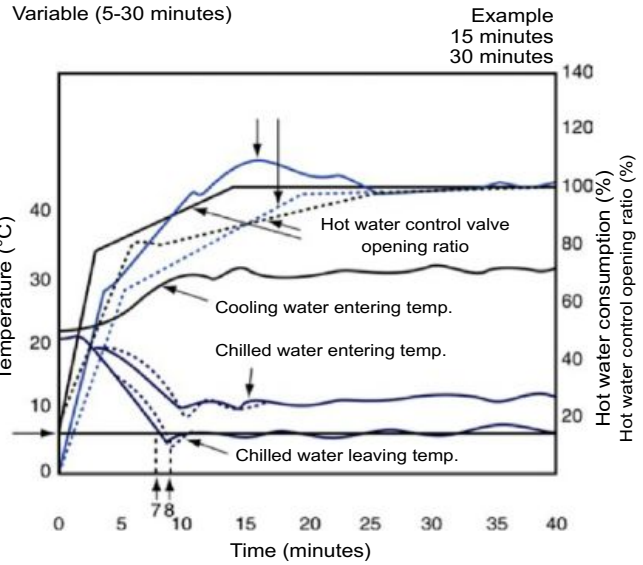

### Expansion of safe operating zone

- This ensures quick response to rapid changes and maintains stable operation.
- The safe operating zone is between 19 °C and 34 °C cooling water temperature (for a nominal cooling water entering temperature of 32 °C).

### Graph 5 - Safe operating zone chart

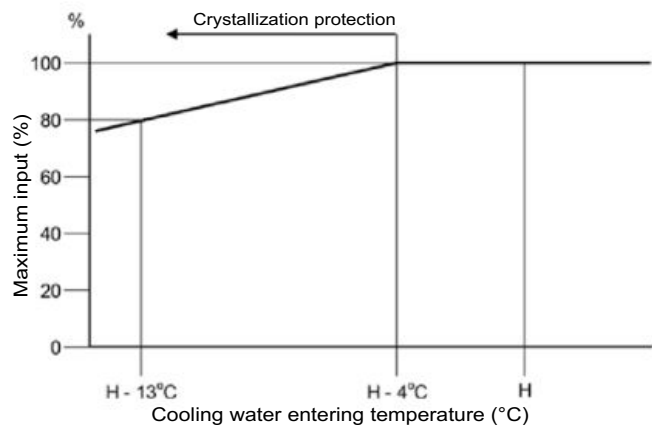

### Crystallisation protection

- A microprocessor monitors the absorbent concentration. Steam supply is stopped, and the unit is returned to normal operation, when the concentration is over a certain limit, to prevent the crystallisation of absorbent



## PERFORMANCES

Model name	16LJ						16LJ-F							
Size	01	02	03	11	12	13	14	21	22	23	24	31	32	
Capacity	KW													
	88	140	176	264	316	387	475	545	633	738	844	949	1055	
<b>Chilled water system <sup>(1)</sup></b>														
Flow rate	l/sec	3,50	5,61	7,00	12,6	15,1	18,5	22,7	26	30,3	35,3	40,3	45,3	50,3
Pressure drop	kPa	71	60	59	72	78	48	53	47	50	101	105	50	52
Connection (DIN)	inch	2	2 1/2	2 1/2	3	3	4	4	5	5	5	5	6	6
Retention volume	m <sup>3</sup>	0,06	0,08	0,08	0,11	0,13	0,15	0,17	0,22	0,25	0,28	0,30	0,35	0,38
<b>Cooling water system <sup>(1)</sup></b>														
Flow rate	l/sec	10,1	16,2	20,2	20,8	25,0	30,6	37,5	43,1	50,0	58,3	66,7	75,0	83,3
Pressure drop	kPa	77	48	49	62	64	72	80	74	78	83	84	114	117
Connection (DIN)	inch	3	4	4	5	5	5	5	6	6	8	8	8	8
Retention volume	m <sup>3</sup>	0,13	0,18	0,23	0,38	0,42	0,48	0,54	0,68	0,74	0,82	0,90	1,12	1,20
<b>Hot water system <sup>(1)</sup></b>														
Flow rate	l/sec	3,06	4,89	6,11	8,4	10,1	12,3	15,1	17,3	20,1	23,4	26,8	30,1	33,5
Pressure drop	kPa	52	31	36	54	54	74	78	74	76	71	71	96	97
Connection (DIN)	inch	2	2 1/2	2 1/2	3	3	4	4	4	4	5	5	5	5
Retention volume	m <sup>3</sup>	0,04	0,06	0,07	0,20	0,22	0,26	0,29	0,38	0,41	0,46	0,50	0,57	0,61
<b>Rupture disk connection</b>	inch	2	2	2	2	2	2	2	2	2	2	2	2	2
<b>Dimensions</b>														
Length (L)	mm	1 745	2 450	2 450	2 640	2 640	3 650	3 650	3 690	3 690	4 770	4 770	5 300	5 300
Height (H)	mm	2 115	2 115	2 115	2 430	2 430	2 430	2 430	2 600	2 600	2 600	2 600	2 840	2 840
Width (W)	mm	1 255	1 255	1 435	1 400	1 400	1 400	1 400	1 500	1 500	1 500	1 500	1 580	1 580
Tube removal	mm	900	1 350	1 350	2 400	2 400	3 400	3 400	3 400	3 400	4 500	4 500	5 000	5 000
<b>Weight</b>														
Operation weight	kg	2 070	2 680	3 150	4 100	4 300	5 200	5 600	6 900	7 300	8 400	8 800	11 000	11 500
Max shipping weight	kg	1 820	2 380	2 720	3 400	3 500	4 400	4 600	5 700	5 900	6 800	7 100	9 000	9 300
Shipping method	u	1	1	1	1	1	1	1	1	1	1	1	1	1
<b>Power supply</b>	V-ph-Hz	400-3-50						400-3-50						
Apparent power	kVA	3,5	3,5	3,5	4,6	4,6	4,6	6,5	6,9	6,9	7,2	7,2	8,6	8,6
Total electric current	A	5,3	5,3	5,3	7,1	7,1	7,1	9,8	10,3	10,3	10,8	10,8	12,8	12,8
Absorbent pump N°1, power input	kW	0,75	0,75	0,75	1,1	1,1	1,1	2,2	2,2	2,2	2,2	2,2	3,0	3,0
Absorbent pump N°1, electric current	A	2,2	2,2	2,2	2,8	2,8	2,8	5,5	5,5	5,5	5,5	5,5	7,5	7,5
Absorbent pump N°2, power input	kW	/	/	/	0,2	0,2	0,2	0,2	0,4	0,4	0,4	0,4	0,4	0,4
Absorbent pump N°2, electric current	A	/	/	/	1,1	1,1	1,1	1,1	1,6	1,6	1,6	1,6	1,6	1,6
Refrigerant pump, power input	kW	0,2	0,2	0,2	0,2	0,2	0,2	0,2	0,2	0,2	0,4	0,4	0,4	0,4
Refrigerant pump, electric current	A	1,1	1,1	1,1	1,1	1,1	1,1	1,1	1,1	1,1	1,6	1,6	1,6	1,6
Purge pump, power input	kW	0,4	0,4	0,4	0,4	0,4	0,4	0,4	0,4	0,4	0,4	0,4	0,4	0,4
Purge pump, electric current	A	1,2	1,2	1,2	1,2	1,2	1,2	1,2	1,2	1,2	1,2	1,2	1,2	1,2
PD cell heater	kW	0,038	0,038	0,038	0,038	0,038	0,038	0,038	0,038	0,038	0,038	0,038	0,038	0,038
Control circuit	kW	0,3	0,3	0,3	0,3	0,3	0,3	0,3	0,3	0,3	0,3	0,3	0,3	0,3

- \* Condition for 16LJ Chilled water temperature 12/6°C (Fouling factor = 0,018 m<sup>2</sup>C/kW)  
Cooling water temperature 29/34°C (Fouling factor = 0,044 m<sup>2</sup>C/kW)  
Hot water temperature 90/80°C (Fouling factor = 0,018 m<sup>2</sup>C/kW)
- \* Condition for 16LJ-F Chilled water temperature 12/7°C (Fouling factor = 0,018 m<sup>2</sup>C/kW)  
Cooling water temperature 29.4/36.3°C (Fouling factor = 0,044 m<sup>2</sup>C/kW)  
Hot water temperature 90/80°C (Fouling factor = 0,018 m<sup>2</sup>C/kW)

PRESENTATION  
COOLING  
HEATING  
AIR TREATMENT  
CONTROLS

## PERFORMANCES

Model name	16LJ-F													
Size	41	42	51	52	53	61	62	63	71	72	73	81	82	
Capacity	KW	1 178	1 319	1 477	1 653	1 846	2 110	2 373	2 637	2 901	3 165	3 428	3 692	3 956
<b>Chilled water system <sup>(1)</sup></b>														
Flow rate	l/sec	56,4	63,1	70,6	78,9	88,3	100,8	113,3	126,1	138,6	151,1	163,9	176,4	188,9
Pressure drop	kPa	45	42	97	47	62	58	77	106	61	93	94	91	92
Connection (DIN)	inch	8	8	8	8	8	10	10	10	12	12	14	14	
Retention volume	m <sup>3</sup>	0,48	0,54	0,75	0,81	0,87	0,98	1,04	1,17	1,41	1,49	1,59	1,77	1,88
<b>Cooling water system <sup>(1)</sup></b>														
Flow rate	l/sec	93,1	104,2	116,7	130,6	145,8	166,7	187,5	208,3	229,2	250,0	270,8	291,7	312,5
Pressure drop	kPa	117	120	102	84	110	140	71	96	130	91	95	96	94
Connection (DIN)	inch	10	10	12	12	14	14	14	14	16	16	16	16	16
Retention volume	m <sup>3</sup>	1,39	1,50	2,37	2,53	2,70	2,94	3,11	3,44	3,47	3,69	3,92	4,31	4,55
<b>Hot water system <sup>(1)</sup></b>														
Flow rate	l/sec	37,4	41,8	46,8	52,4	58,5	66,9	75,2	83,6	91,9	101	109	117	126
Pressure drop	kPa	97	98	88	37	49	46	61	83	61	93	94	93	92
Connection (DIN)	inch	6	6	6	8	8	10	10	10	10	10	10	10	10
Retention volume	m <sup>3</sup>	0,74	0,8	1,02	1,09	1,17	1,42	1,51	1,69	1,98	2,08	2,20	2,50	2,61
<b>Rupture disk connection</b>	inch	2	2	2	2	2	2	2	2	2	2	2	2	2
<b>Dimensions</b>														
Length (L)	mm	5 330	5 330	5 500	5 950	6 480	6 710	7 210	8 230	7 230	8 220	8 220	8 320	8 320
Height (H)	mm	3 080	3 080	3 450	3 450	3 450	3 680	3 680	3 680	4 000	4 000	4 000	4 180	4 180
Width (W)	mm	1 690	1 690	2 000	2 000	2 000	2 230	2 230	2 230	2 730	2 730	2 730	3 010	3 010
Tube removal	mm	5 000	5 000	5 100	5 700	6 200	6 200	6 700	7 700	6 700	7 700	7 700	7 700	7 700
<b>Weight</b>														
Operation weight	kg	13 700	14 300	20 200	21 500	22 800	28 300	30 100	33 500	39 100	42 400	43 700	46 300	49 200
Max shipping weight	kg	11 100	11 500	16 000	17 100	18 100	11 200	11 800	12 900	14 600	15 800	16 200	17 900	18 400
Shipping method	u	1	1	1	1	1	2	2	2	2	2	2	2	2
<b>Power supply</b>	V-ph-Hz	400-3-50												
Apparent power	kVA	8,6	8,6	10,2	10,2	9,4	18,8	18,8	18,8	19,3	20,9	22,0	22,0	22,0
Total electric current	A	12,8	12,8	15,1	15,1	13,9	27,5	27,5	27,5	28,2	30,5	32,2	32,2	32,2
Absorbent pump N°1, power input	kW	3,0	3,0	3,0	3,0	3,0	7,5	7,5	7,5	7,5	7,5	7,5	7,5	7,5
Absorbent pump N°1, electric current	A	7,5	7,5	7,5	7,5	7,5	19,0	19,0	19,0	19,0	19,0	19,0	19,0	19,0
Absorbent pump N°2, power input	kW	0,4	0,4	1,3	1,3	0,75	1,5	1,5	1,5	1,5	1,5	2,2	2,2	2,2
Absorbent pump N°2, electric current	A	1,6	1,6	3,9	3,9	2,7	4,8	4,8	4,8	4,8	4,8	6,5	6,5	6,5
Refrigerant pump, power input	kW	0,4	0,3	0,3	0,3	0,3	0,3	0,3	0,3	0,75	0,75	1,2	1,2	1,2
Refrigerant pump, electric current	A	1,6	1,6	1,6	1,6	1,6	1,6	1,6	1,6	1,6	3,9	3,9	3,9	3,9
Purge pump, power input	kW	0,4	0,4	0,4	0,4	0,4	0,4	0,4	0,4	0,75	0,75	0,75	0,75	0,75
Purge pump, electric current	A	1,2	1,2	1,2	1,2	1,2	1,2	1,2	1,2	1,9	1,9	1,9	1,9	1,9
PD cell heater	kW	0,038	0,038	0,038	0,038	0,038	0,038	0,038	0,038	0,038	0,038	0,038	0,038	0,038
Control circuit	kW	0,3	0,3	0,3	0,3	0,3	0,3	0,3	0,3	0,3	0,3	0,3	0,3	0,3

\* Condition for 16LJ-F Chilled water temperature 12/7°C (Fouling factor = 0,018 m<sup>2</sup>/kW)  
 Cooling water temperature 29.4/36.3°C (Fouling factor = 0,044 m<sup>2</sup>/kW)  
 Hot water temperature 90/80°C (Fouling factor = 0,018 m<sup>2</sup>/kW)

**SCOPE OF ORDER 16LJ SIZE 01-02-03**

Item	Standard	Option
Standard	CE marking	No option
<b>Chilled water</b>		
Temperature	Inlet : 12°C Outlet : 6°C	Outlet : 5°C through 12°C Temperature difference 3K through 10K
Flow rate	0,504m³/h x RT	Changes depending on chilled water temperature Difference.
Max. working pressure	0,784 MPa	No option
Hydraulic test pressure	Max. working pressure x 1,5	No option
Fouling factor	0,018m²°C/kW	Max. 0,18m²°C/kW
Material of tube	Copper tube	No option
Water quality	Refer to JRA-GL02E-1994	No option
Structure of water header	Welded type	No option
Manufacturing standard of water header	Carrier standard, DIN flange	No option
<b>Cooling water</b>		
Temperature	Inlet : 29°C Outlet : 34°C	Inlet : 20°C through 40°C
Flow rate	1,457m³/h x RT	Within water flow range of each model
Max. working pressure	0,784 MPa	No option
Hydraulic test pressure	Max. working pressure x 1,5	No option
Fouling factor	0,044m²°C/kW	Max. 0,18m²°C/kW
Material of tube	Copper tube	No option
Water quality	Refer to JRA-GL02E-1994	No option
Structure of water header	Marine type	No option
Manufacturing standard of water header	Carrier standard, DIN flange	No option
<b>Hot water</b>		
Temperature	Inlet : 90°C Outlet : 80°C	Inlet: 80°C through 110°C Outlet : Min. 70°C
Flow rate	0,122 l/s x RT	Within water flow range of each model
Max. working pressure	0,784 MPa	No option
Hydraulic test pressure	Max. working pressure x 1,5	No option
Fouling factor	0,018m²°C/kW	Max. 0,18m²°C/kW
Material of tube	Copper tube	No option
Water quality	Refer to JRA-GL02E-1994	No option
Structure of water header	Marine type	No option
Manufacturing standard of water header	Carrier standard, DIN flange	No option
<b>Electricity</b>		
Power supply	400 V - 3 phase - 50Hz (Voltage within ±10%, Frequency within ±5%)	No option
<b>Shipment</b>	One section	No option
<b>Control</b>		
Safety functions	Refrigerant temperature	Cooling water flow switch
	Chilled water freeze protection	
	Chilled water flow switch	
	Cooling water temperature	
	Generator temperature	
	Chrystallization protection	
Capacity control	Motor protection	
	Digital PID control by Chilled water temperature Chilled water temperature remote control (4 - 20 mA)	

## SCOPE OF ORDER 16LJ SIZE 01-02-03

Item	Standard	Option
<b>Control panel</b>		
Paint finish	Munsell 1Y-8,5/0,5	No option
Indication lamps	Operation: Green	No option
	Stop: Orange	
	Alarm: Red	
Display	LED	No option
	Operation indication	No option
External terminals (No-voltage normal open contact)	Stop indication	
	Alarm indication	
	Answer back indication	
	Cooling mode indication	
	Purge alarm indication	
Structure	Indoor type	No option
<b>External panel painting</b>	Munsell 1Y-8,5/0,5	No option
<b>Insulation</b>	Factory insulated	No option
<b>Electrical wiring</b>	600V polyvinyl grade chloride insulated wire	No option
<b>Installation condition</b>		
Place	Indoor	No option
Ambient temperature	5°C through 40°C	No option
Ambient humidity	Relative humidity: Max. 90% at 45°C	No option
Atmosphere	Be sure the followings are not present	No option
	- Corrosive gas	
	- Explosive gas	
	- Poisonous gas	
<b>Factory test</b>		
	Vacuum-side leak test	Performance test at full load
	Electric insulation resistance test	
	Dielectric breakdown test	
	Function test of electric circuit	

**SCOPE OF ORDER 16LJ-F SIZE 11-82**

Item	Standard	Option
Standard	CE marking	No option
<b>Chilled water</b>		
Temperature	Inlet : 12°C Outlet : 7°C	Outlet : 5°C through 12°C Temperature difference 3K through 10K
Flow rate	0,605m <sup>3</sup> /h x RT	Changes depending on chilled water temperature Difference.
Max. working pressure	1,0 MPa	Max. 2,0 MPa
Hydraulic test pressure	Max. working pressure x 1,5	No option
Fouling factor	0,018m <sup>2</sup> °C/kW	Max. 0,18m <sup>2</sup> °C/kW
Material of tube	Copper tube	Contact Carrier
Water quality	Refer to JRA-GL02E-1994	No option
Structure of water header	Removal type, Epoxy treated	No option
Manufacturing standard of water header	Carrier standard, DIN flange	No option
<b>Cooling water</b>		
Temperature	Inlet : 29,4°C Outlet : 36,3°C	Inlet : 20°C through 40°C
Flow rate	1,0m <sup>3</sup> /h x RT	Within water flow range of each model
Max. working pressure	1,0 MPa	Max. 2,0 MPa
Hydraulic test pressure	Max. working pressure x 1,5	No option
Fouling factor	0,044m <sup>2</sup> °C/kW	Max. 0,18m <sup>2</sup> °C/kW
Material of tube	Absorber: Copper, Condenser: Stainless steel	Contact Carrier
Water quality	Refer to JRA-GL02E-1994	No option
Structure of water header	Marine type, Epoxy treated	No option
Manufacturing standard of water header	Carrier standard, DIN flange	No option
<b>Hot water</b>		
Temperature	Inlet : 90°C Outlet : 80°C	Inlet: Max. 110°C Outlet : Min. 70°C
Flow rate	0,122 l/s x RT	Within water flow range of each model
Max. working pressure	1,0 MPa	Max. 2,0 MPa
Hydraulic test pressure	Max. working pressure x 1,5	No option
Fouling factor	0,018m <sup>2</sup> °C/kW	Max. 0,18m <sup>2</sup> °C/kW
Material of tube	Stainless steel (SUS436L)	Contact Carrier
Water quality	Refer to JRA-GL02E-1994	No option
Structure of water header	16LJ-F11-63: Removal type, 71 - 82: Marine type	Marine type for 16LJ-F11-63
Manufacturing standard of water header	Carrier standard, DIN flange	No option
<b>Electricity</b>		
Power supply	400 V - 3 phase - 50Hz (Voltage within ±10%, Frequency within ±5%)	No option
<b>Shipment</b>	16LJ-F11- 53: One section, 61 - 82: Two section	Two section shipment for 16LJ-F11 - 53
<b>Control</b>		
Safety functions	Refrigerant temperature	Cooling water flow switch
	Chilled water freeze protection	
	Chilled water flow switch	
	Cooling water temperature	
	Generator temperature	
	Chrystallization protection	
Capacity control	Motor protection	
	Digital PID control by Chilled water temperature Chilled water temperature remote control (4 - 20 mA)	



## SCOPE OF ORDER 16LJ-F SIZE 11-82

Item	Standard	Option
<b>Control panel</b>		
Paint finish	Munsell 5Y-7/1	No option
Indication lamps	Operation: Green	No option
	Stop: Orange	
	Alarm: Red	
Display	8,4 inch color touch panel	No option
	Operation indication	No option
External terminals (No-voltage normal open contact)	Stop indication	
	Alarm indication	
	Answer back indication	
	Cooling mode indication	
	Purge alarm indication	
BMS	Modbus	BACnet
Structure	Indoor type	No option
<b>Electrical wiring</b>	600V polyvinyl grade chloride insulated wires	No option
<b>Insulation condition</b>		
Place	Be sure the followings are not present	No option
Ambient temperature	Corrosive gas	No option
Ambient humidity	Relative humidity: Max. 90% at 45°C	No option
Atmosphere	Be sure the followings are not present	No option
	- Corrosive gas	
	- Explosive gas	
	- Poisonous gas	
<b>Factory test</b>		
	Vacuum-side leak test	Performance test at full load
	Electric insulation resistance test	
	Dielectric breakdown test	
	Function test of electric circuit	

## SCOPE OF SUPPLY

### 1. Standards met

The units comply with the following standards:

- ARI560 - 2000
- 2006/42/EC (machine directive)
- 2014/35/EU (low-voltage directive)
- 2014/30/EU (electromagnetic compatibility directive)
- 2014/68/EU (pressure equipment directive)

### 2. Absorption chiller, comprising:

1. Lower shell
  - Evaporator and refrigerant dispersion tray
  - Absorber and absorbent dispersion tray
  - Eliminators
  - Bases.
2. Upper shell
  - Generator with eliminators
  - Condenser with eliminators
  - Rupture disk.
3. Heat exchangers with refrigerant drain heat reclaimer
4. Pumps
  - Absorbent pump No. 1 with isolating valves
  - Absorbent pump No. 2 with isolating valves (16LJ-F only)
  - Refrigerant pump with isolating valves (isolating valves only on 16LJ-F31 or above)
  - Purge pump.
5. Purge unit
  - Purge tank with ejector device
  - Diaphragm valves and piping with liquid trap
  - Pressure sensor
  - Palladium cell with heater
6. Control panel
  - Controller with data display
  - LEDs and operation buttons
  - Inverter for absorbent pump (option)
  - Circuit breaker
  - Transformer
  - Relays and terminal blocks
  - Purge pump operation switch
7. Locally mounted parts
  - Temperature sensors
  - Chilled-water flow switch
8. Interconnecting piping and wiring
  - Refrigerant and absorbent piping
  - Internal power and control wiring
9. Initial charge
  - Absorbent (lithium bromide)
  - Refrigerant (water)
  - Inhibitor (lithium molybdate).

### 10. Painting

- Main unit: Rust-preventive paint
- Control panel: Finish paint.

### 11. Accessories

- Operation manual
  - Washer (for fixing foundation bolts)
  - Gasket and sealant for rupture disk
  - Purge pump oil
12. External panel (16LJ-01 to 03 only)
  13. Thermal insulation (16LJ-01 to 03 only)

### ■ Evaporator

### ■ Generator

### ■ Heat exchanger

### 3. Factory test

1. Check of external dimensions
2. Hydraulic pressure test of water headers  
Test pressure is 1.5 times of maximum working pressure
3. Vacuum-side leak test
4. Electric insulation resistance test
5. Dielectric breakdown test
6. Function test of electric circuit and safety devices

### 4. Scope of supply of the purchaser

1. Building and foundations
2. External chilled water, cooling water and hot water piping work including various safety valves, isolation valves, mating flanges, gasket, bolts and nuts, etc.
3. External wiring and piping for the chillers including necessary parts
4. Insulation for the chillers including necessary parts. (16LJ-F)
5. Finish painting of the chillers (if needed)
6. Cooling water entering temperature control device
7. Cooling water treatment device
8. Various temperature/pressure gauges for water lines.
9. Cooling tower(s), chilled-water pump(s), hot water pump(s) and cooling water pump(s)
10. Electric power supply (as specified)
11. Supply of chilled water, cooling water, hot water at rated conditions
12. Maintenance of the chiller
13. Necessary tools, labour and materials for installation and site test operation
14. Any other item not specifically mentioned in the scope of supply.

## PASS AND NOZZLES ARRANGEMENT

### 16LJ-F11-82

	Chilled water										Cooling water 6 pass											
	6 pass		5 pass		4 pass		3 pass		2 pass		4+3 pass		4+2 pass		3+2 pass		3+1 pass		2+2 pass		2+1 pass	
	In	Out	In	Out	In	Out	In	Out	In	Out	In	Out	In	Out	In	Out	In	Out	In	Out	In	Out
11	L	L	R	L	L	L	R	L	L	L	R	L	L	L	L	R	R	R	L	L	R	L
12	L	L	R	L	L	L	R	L	L	L	R	L	L	L	L	R	R	R	L	L	R	L
13	L	L	R	L	L	L	R	L	L	L	R	L	L	L	L	R	R	R	L	L	R	L
14	L	L	R	L	L	L	R	L	L	L	R	L	L	L	L	R	R	R	L	L	R	L
21	L	L	R	L	L	L	R	L	L	L	R	L	L	L	L	R	R	R	L	L	R	L
22	L	L	R	L	L	L	R	L	L	L	-	-	L	L	L	R	R	R	L	L	R	L
23	L	L	R	L	L	L	R	L	L	L	R	L	L	L	L	R	R	R	L	L	R	L
24	L	L	R	L	L	L	R	L	L	L	-	-	L	L	L	R	R	R	L	L	R	L
31	-	-	R	L	L	L	R	L	L	L	R	L	L	L	L	R	R	R	L	L	R	L
32	-	-	R	L	L	L	R	L	L	L	-	-	L	L	L	R	R	R	L	L	R	L
41	-	-	R	L	L	L	R	L	L	L	-	-	L	L	L	R	R	R	L	L	R	L
42	-	-	R	L	L	L	R	L	L	L	-	-	L	L	L	R	R	R	L	L	R	L
51	-	-	R	L	L	L	R	L	L	L	-	-	L	L	L	R	R	R	L	L	R	L
52	-	-	R	L	L	L	R	L	L	L	-	-	L	L	L	R	R	R	L	L	R	L
53	-	-	R	L	L	L	R	L	L	L	-	-	L	L	L	R	R	R	L	L	R	L
61	-	-	-	-	L	L	R	L	L	L	-	-	L	L	L	R	R	R	L	L	R	L
62	-	-	-	-	L	L	R	L	L	L	-	-	L	L	L	R	R	R	L	L	R	L
63	-	-	-	-	L	L	R	L	L	L	-	-	L	L	L	R	R	R	L	L	R	L
71	-	-	-	-	-	-	L	R	R	R	-	-	-	-	R	L	L	L	R	R	L	R
72	-	-	-	-	-	-	L	R	R	R	-	-	-	-	R	L	L	L	R	R	L	R
73	-	-	-	-	-	-	L	R	R	R	-	-	-	-	R	L	L	L	R	R	L	R
81	-	-	-	-	-	-	L	R	R	R	-	-	-	-	R	L	L	L	R	R	L	R
82	-	-	-	-	-	-	L	R	R	R	-	-	-	-	R	L	L	L	R	R	L	R

	Hot water													
	14 pass		12 pass		10 pass		8 pass		6 pass		4 pass		2 pass	
	In	Out	In	Out	In	Out	In	Out	In	Out	In	Out	In	Out
11	R	R	-	-	R	R	-	-	R	R	R	R	-	-
12	R	R	-	-	R	R	-	-	R	R	R	R	-	-
13	R	R	-	-	R	R	-	-	R	R	R	R	-	-
14	R	R	-	-	R	R	-	-	R	R	R	R	-	-
21	-	-	R	R	-	-	R	R	R	R	R	R	-	-
22	-	-	R	R	-	-	R	R	R	R	R	R	-	-
23	-	-	R	R	-	-	R	R	R	R	R	R	-	-
24	-	-	R	R	-	-	R	R	R	R	R	R	-	-
31	-	-	-	-	R	R	-	-	R	R	R	R	-	-
32	-	-	-	-	R	R	-	-	R	R	R	R	-	-
41	-	-	-	-	R	R	-	-	R	R	R	R	-	-
42	-	-	-	-	R	R	-	-	R	R	R	R	-	-
51	-	-	-	-	R	R	-	-	R	R	R	R	-	-
52	-	-	-	-	R	R	-	-	R	R	R	R	-	-
53	-	-	-	-	R	R	-	-	R	R	R	R	-	-
61	-	-	-	-	R	R	-	-	R	R	R	R	-	-
62	-	-	-	-	R	R	-	-	R	R	R	R	-	-
63	-	-	-	-	R	R	-	-	R	R	R	R	-	-
71	-	-	-	-	-	-	-	-	R	R	R	R	R	R
72	-	-	-	-	-	-	-	-	R	R	R	R	R	R
73	-	-	-	-	-	-	-	-	R	R	R	R	R	R
81	-	-	-	-	-	-	-	-	R	R	R	R	R	R
82	-	-	-	-	-	-	-	-	R	R	R	R	R	R

**Legende**

- L Nozzle location on **LEFT** end (when facing control panel)
- R Nozzle location on **RIGHT** end (when facing controlpanel)
- Standard pass arrangement

## DIMENSIONS/CLEARANCES

### 16LJ-01

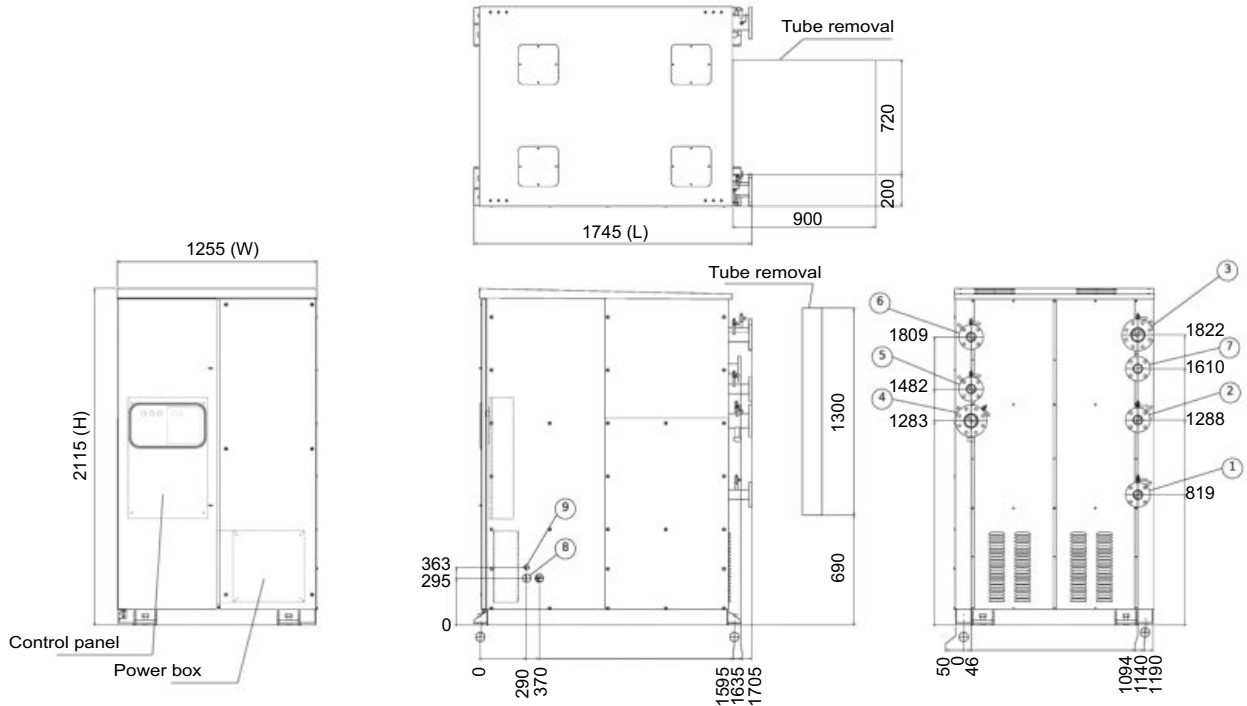

- ① Chilled water inlet
- ② Chilled water outlet
- ③ Cooling water inlet
- ④ Cooling water outlet
- ⑤ Hot water inlet
- ⑥ Hot water outlet
- ⑦ Rupture disk
- ⑧ Hole for power supply
- ⑨ Hole for signal wire

#### NOTES:

- (1) Dimensions (L), (W), (H), are for standard machine. The dimensions are changed by parts added.
- (2) ⚙ indicates the position of anchor bolts.
- (3) Clearance space must be saved either side of the chiller.
- (4) Connecting flange of all external water piping are DIN 10 flange.
- (5) ⚡ indicates the position of the power supply connection on control panel. (Dia. 35 mm).
- (6) Installation clearance
  - Longitudinal distance                    1000 mm
  - Top    200 mm
  - Others    500 mm

NOTE: Dimensions are for guidance only. Always refer to the certified drawings supplied upon request when designing an installation.

## DIMENSIONS/CLEARANCES

### 16LJ-02

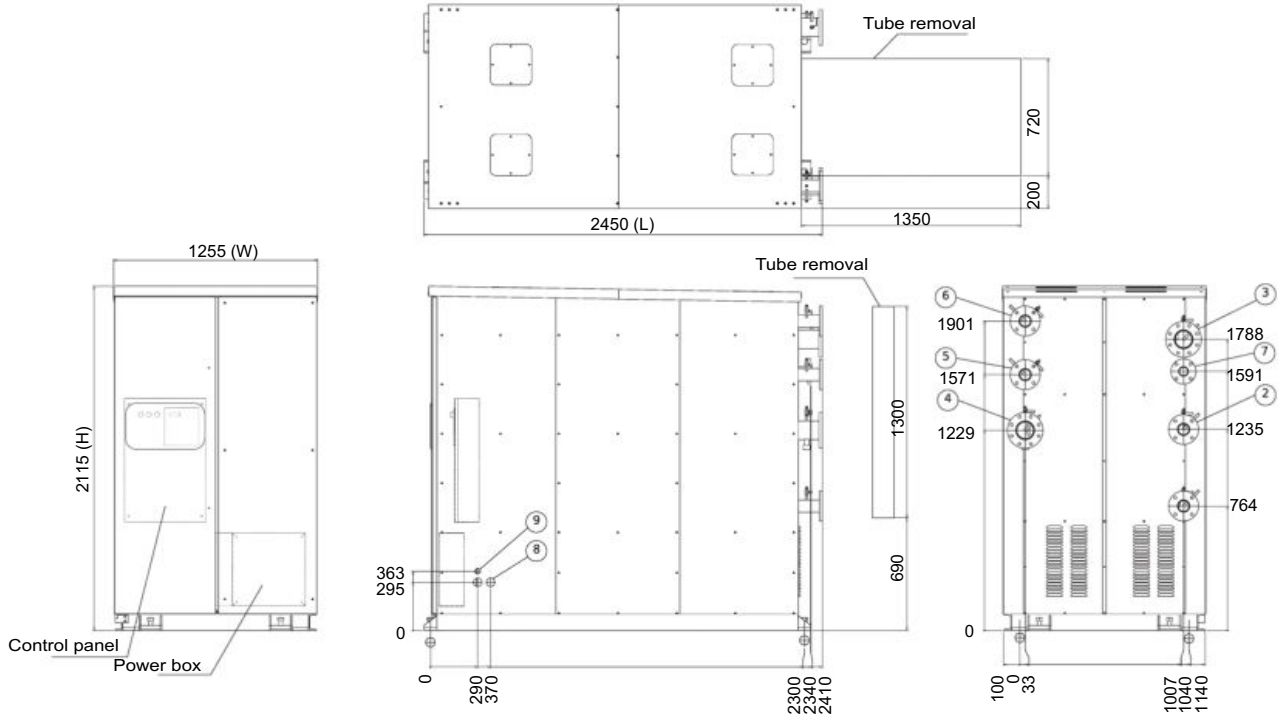

- ① Chilled water inlet
- ② Chilled water outlet
- ③ Cooling water inlet
- ④ Cooling water outlet
- ⑤ Hot water inlet
- ⑥ Hot water outlet
- ⑦ Rupture disk
- ⑧ Hole for power supply
- ⑨ Hole for signal wire

#### NOTES:

- (1) Dimensions (L), (W), (H), are for standard machine. The dimensions are changed by parts added.
- (2) ⚓ indicates the position of anchor bolts.
- (3) Clearance space must be saved either side of the chiller.
- (4) Connecting flange of all external water piping are DIN 10 flange.
- (5) ⬆ indicates the position of the power supply connection on control panel. (Dia. 35 mm).
- (6) Installation clearance
  - Longitudinal distance      1000 mm
  - Top                                      200 mm
  - Others                                  500 mm

NOTE: Dimensions are for guidance only. Always refer to the certified drawings supplied upon request when designing an installation.



## DIMENSIONS/CLEARANCES

### 16LJ-03

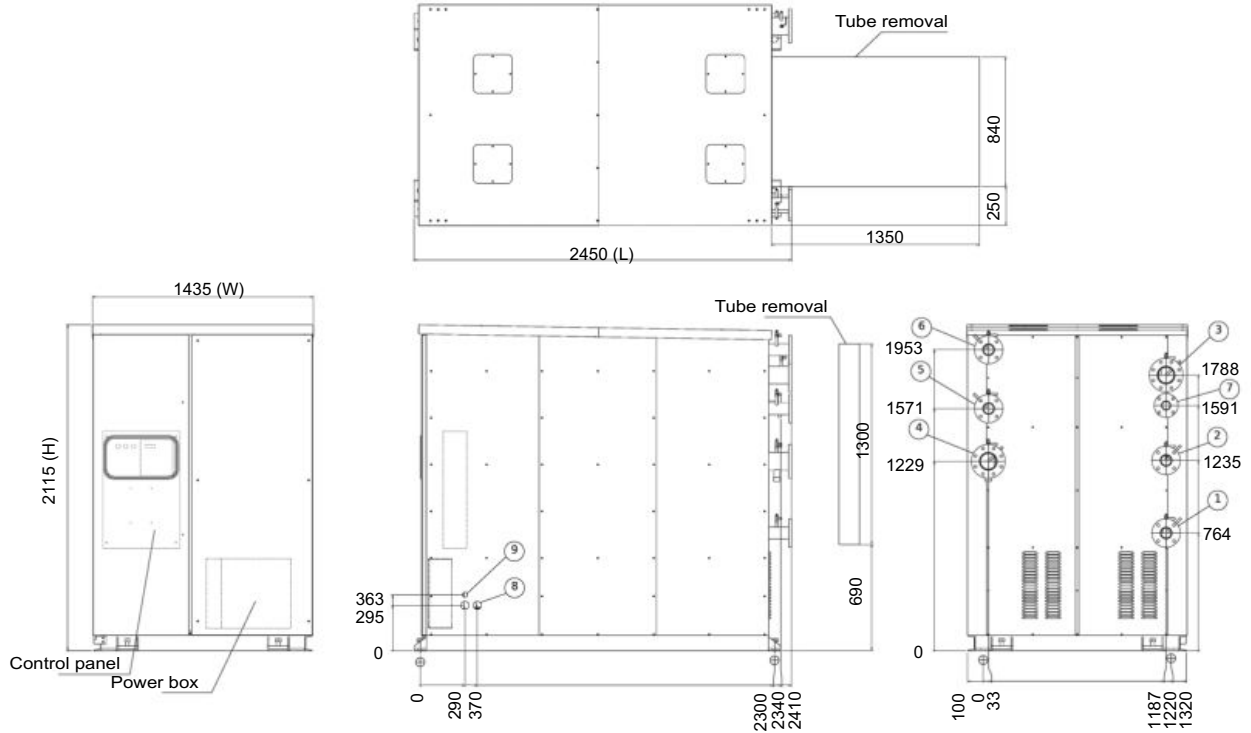

- ① Chilled water inlet
- ② Chilled water outlet
- ③ Cooling water inlet
- ④ Cooling water outlet
- ⑤ Hot water inlet
- ⑥ Hot water outlet
- ⑦ Rupture disk
- ⑧ Hole for power supply
- ⑨ Hole for signal wire

#### NOTES:

- (1) Dimensions (L), (W), (H), are for standard machine. The dimensions are changed by parts added.
- (2) ⚓ indicates the position of anchor bolts.
- (3) Clearance space must be saved either side of the chiller.
- (4) Connecting flange of all external water piping are DIN 10 flange.
- (5) ⬆ indicates the position of the power supply connection on control panel. (Dia. 35 mm).
- (6) Installation clearance
  - Longitudinal distance      1000 mm
  - Top                                200 mm
  - Others                            500 mm

NOTE: Dimensions are for guidance only. Always refer to the certified drawings supplied upon request when designing an installation.

## DIMENSIONS/CLEARANCES

### 16LJ-F11 through 16LJ-F12

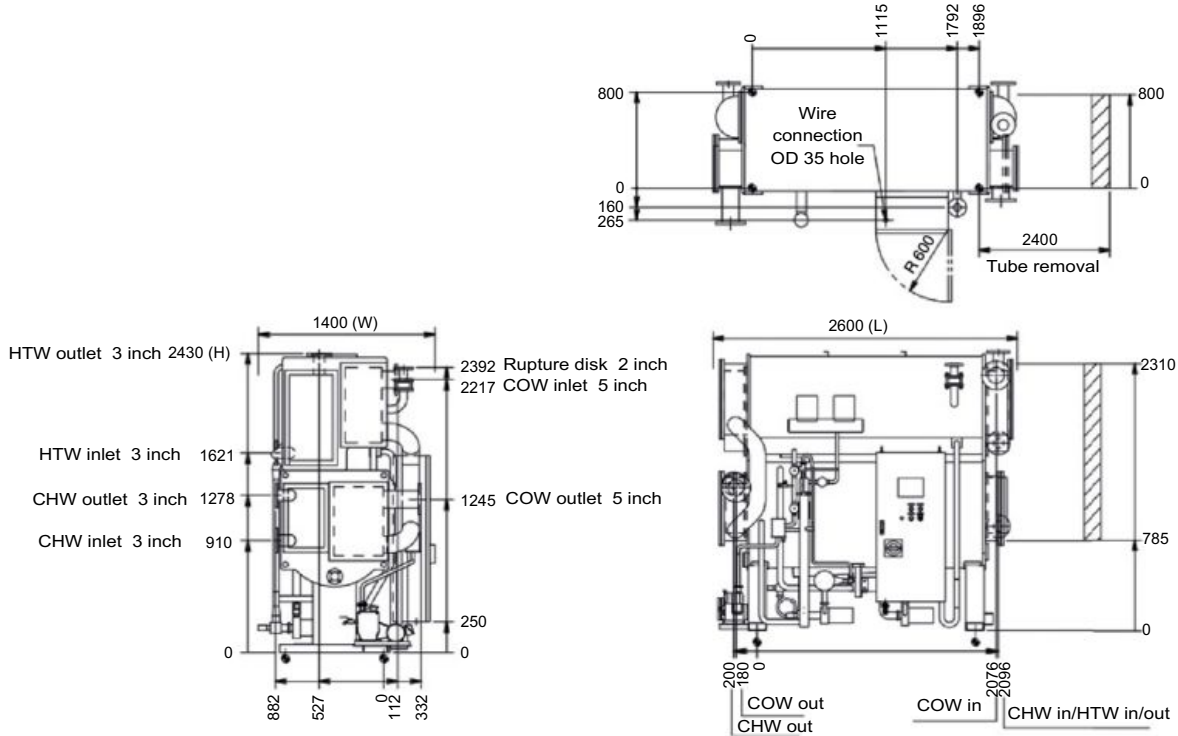

### 16LJ-F13 through 16LJ-F14

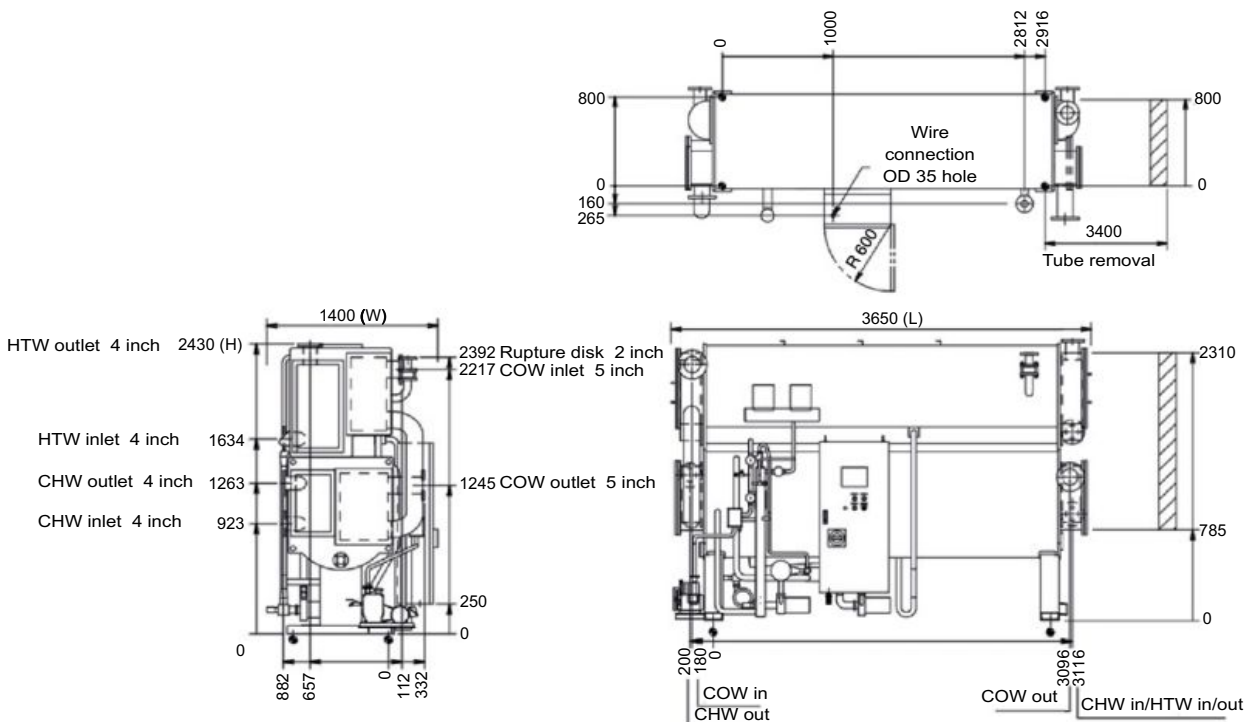

**NOTES:**

- (1) Dimensions (L), (W), (H), are for standard machine. The dimensions are changed by parts added.
- (2) indicates the position of anchor bolts.
- (3) Clearance space must be saved either side of the chiller.
- (4) Connecting flange of all external water piping are DIN 10 flange.
- (5) indicates the position of the power supply connection on control panel. (Dia. 35 mm).
- (6) Installation clearance
  - Longitudinal distance 1000 mm
  - Top 200 mm
  - Others 500 mm

NOTE: Dimensions are for guidance only. Always refer to the certified drawings supplied upon request when designing an installation.

## DIMENSIONS/CLEARANCES

### 16LJ-F21 through 16LJ-F22

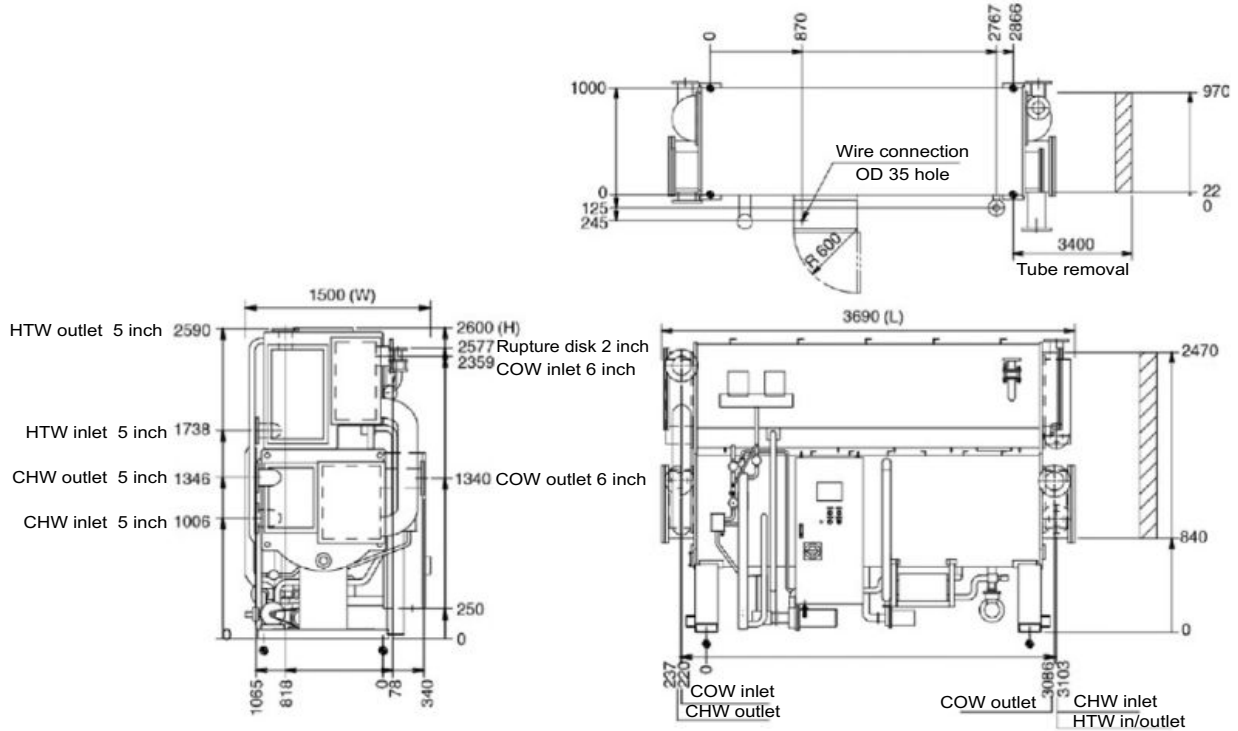

### 16LJ-F23 through 16LJ-F24

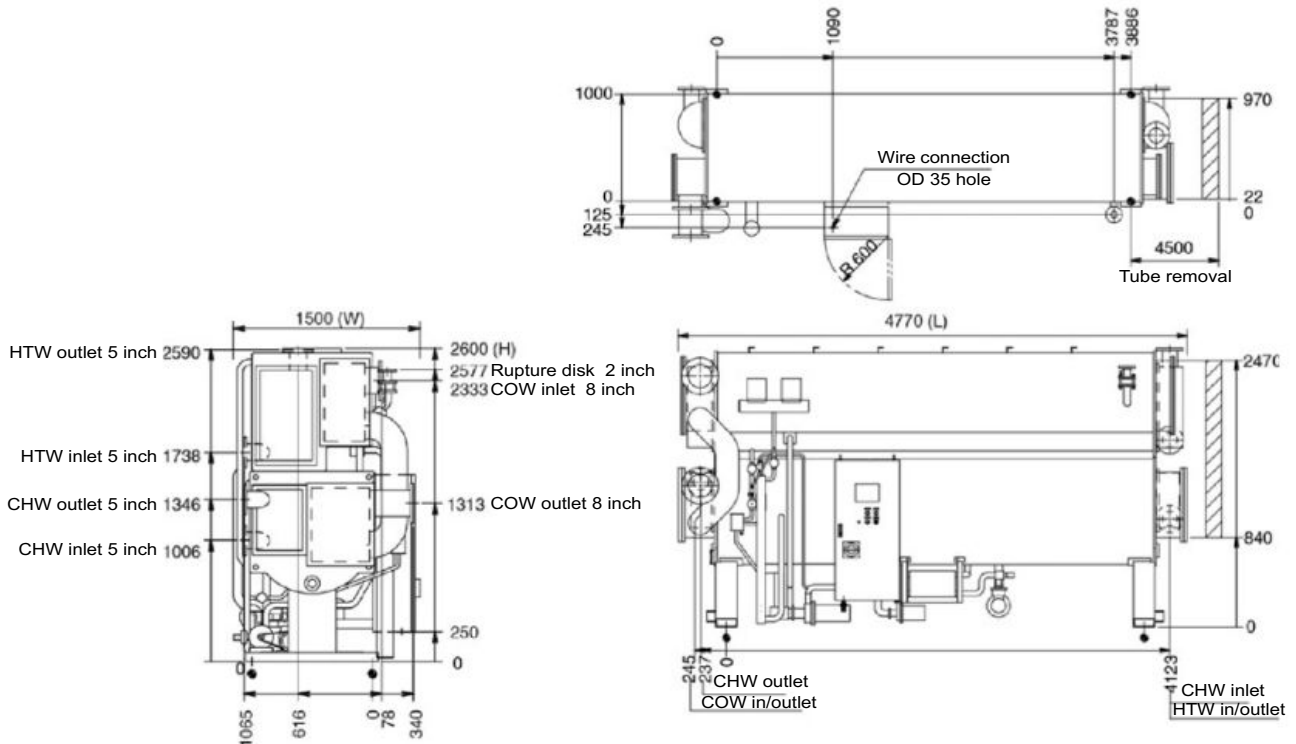

**NOTES:**

- (1) Dimensions (L), (W), (H), are for standard machine. The dimensions are changed by parts added.
- (2) indicates the position of anchor bolts.
- (3) Clearance space must be saved either side of the chiller.
- (4) Connecting flange of all external water piping are DIN 10 flange.
- (5) indicates the position of the power supply connection on control panel. (Dia. 35 mm).
- (6) Installation clearance
 

- Longitudinal distance	1000 mm
- Top	200 mm
- Others	500 mm

NOTE: Dimensions are for guidance only. Always refer to the certified drawings supplied upon request when designing an installation.

## DIMENSIONS/CLEARANCES

### 16LJ-F31 through 16LJ-F32

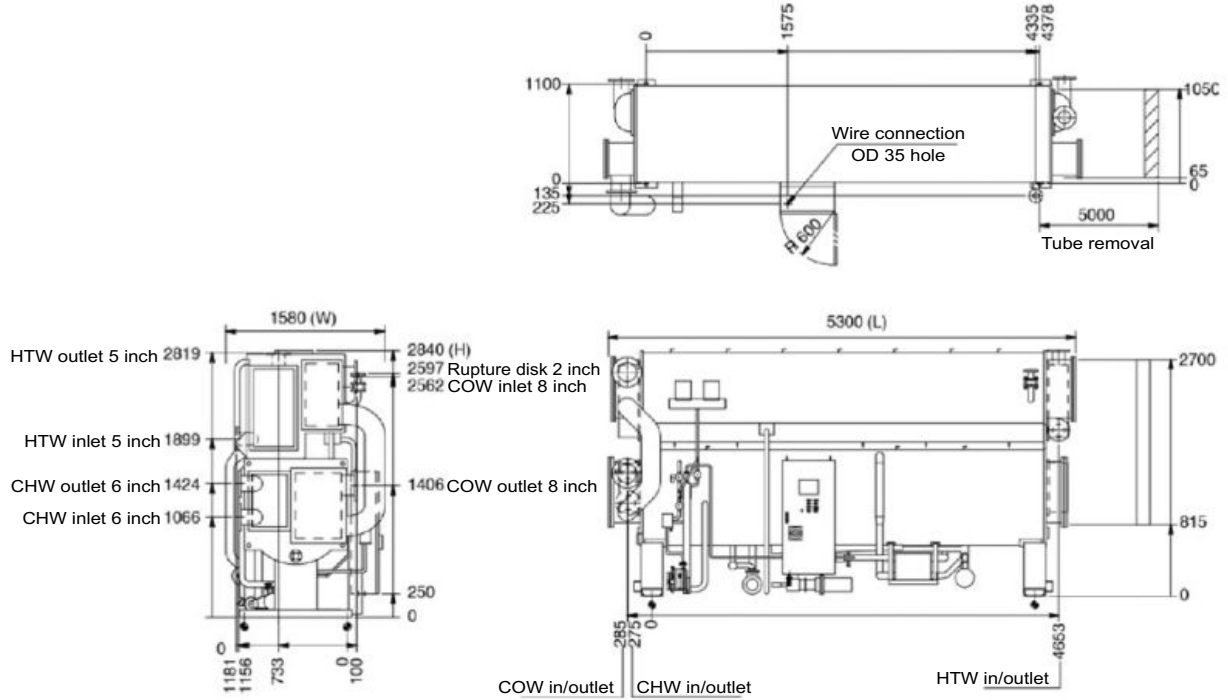

### 16LJ-F41 through 16LJ-F42

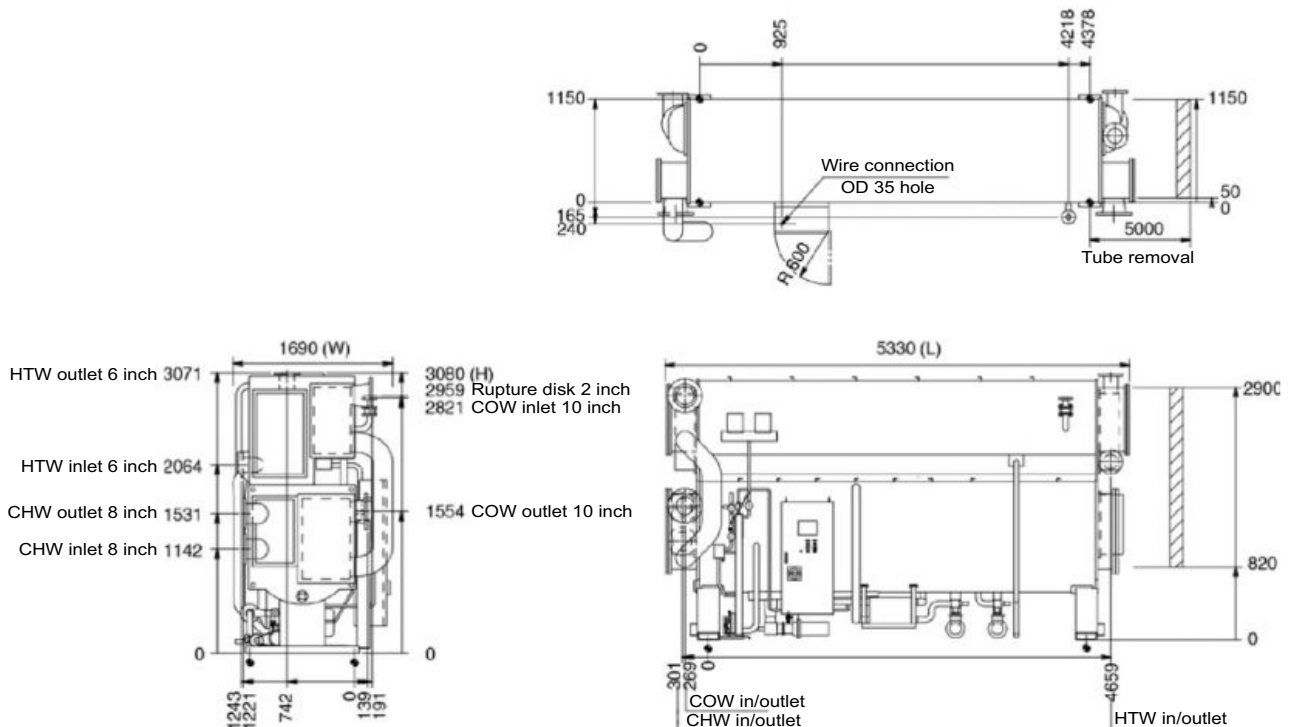

**NOTES:**

- (1) Dimensions (L), (W), (H), are for standard machine. The dimensions are changed by parts added.
- (2) ⚓ indicates the position of anchor bolts.
- (3) Clearance space must be saved either side of the chiller.
- (4) Connecting flange of all external water piping are DIN 10 flange.
- (5) ⬆ indicates the position of the power supply connection on control panel. (Dia. 35 mm).
- (6) Installation clearance
 

- Longitudinal distance	1000 mm
- Top	200 mm
- Others	500 mm

NOTE: Dimensions are for guidance only. Always refer to the certified drawings supplied upon request when designing an installation.

## DIMENSIONS/CLEARANCES

### 16LJ-F51

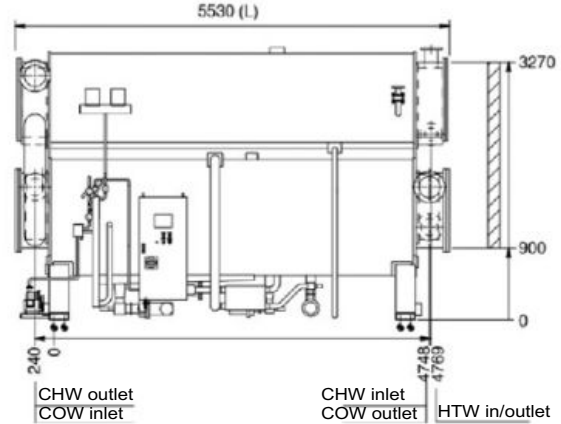
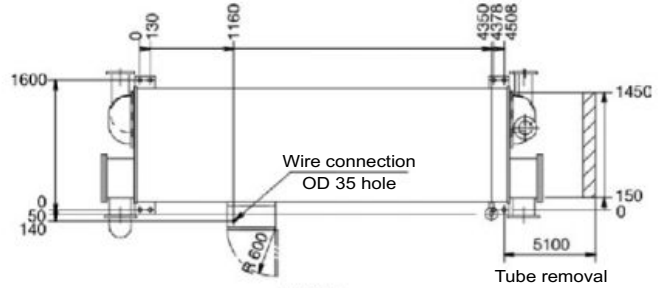
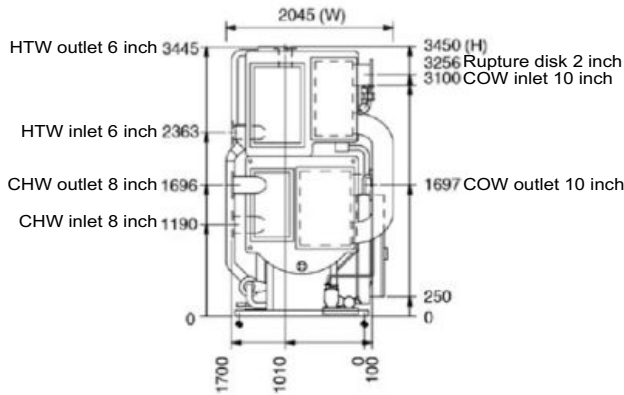

### 16LJ-F52

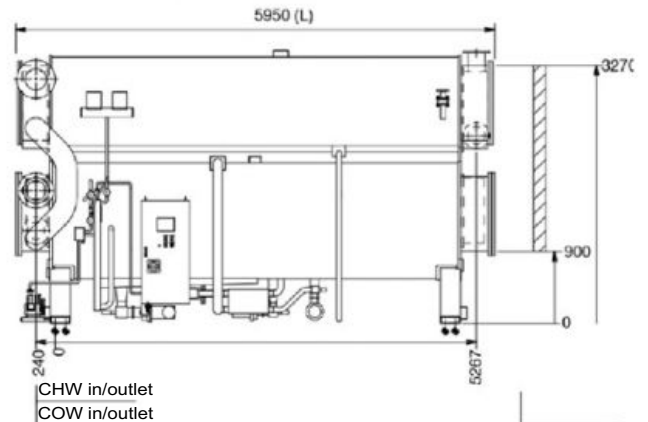
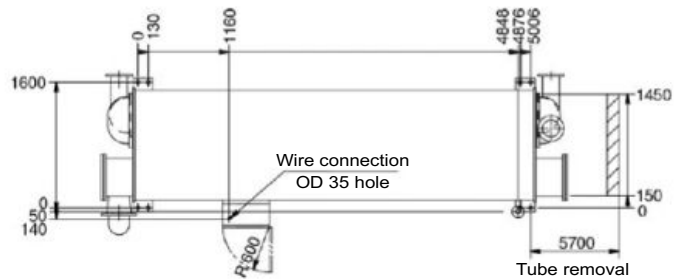
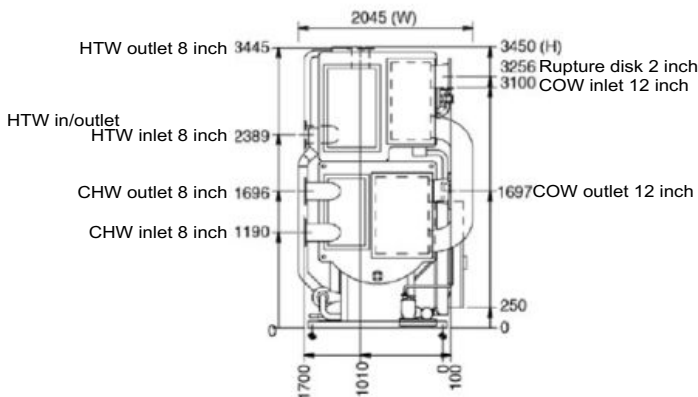

#### NOTES:

- (1) Dimensions (L), (W), (H), are for standard machine. The dimensions are changed by parts added.
- (2) indicates the position of anchor bolts.
- (3) Clearance space must be saved either side of the chiller.
- (4) Connecting flange of all external water piping are DIN 10 flange.
- (5) indicates the position of the power supply connection on control panel. (Dia. 35 mm).
- (6) Installation clearance
 

- Longitudinal distance	1000 mm
- Top	200 mm
- Others	500 mm

NOTE: Dimensions are for guidance only. Always refer to the certified drawings supplied upon request when designing an installation.



## DIMENSIONS/CLEARANCES

### 16LJ-F53

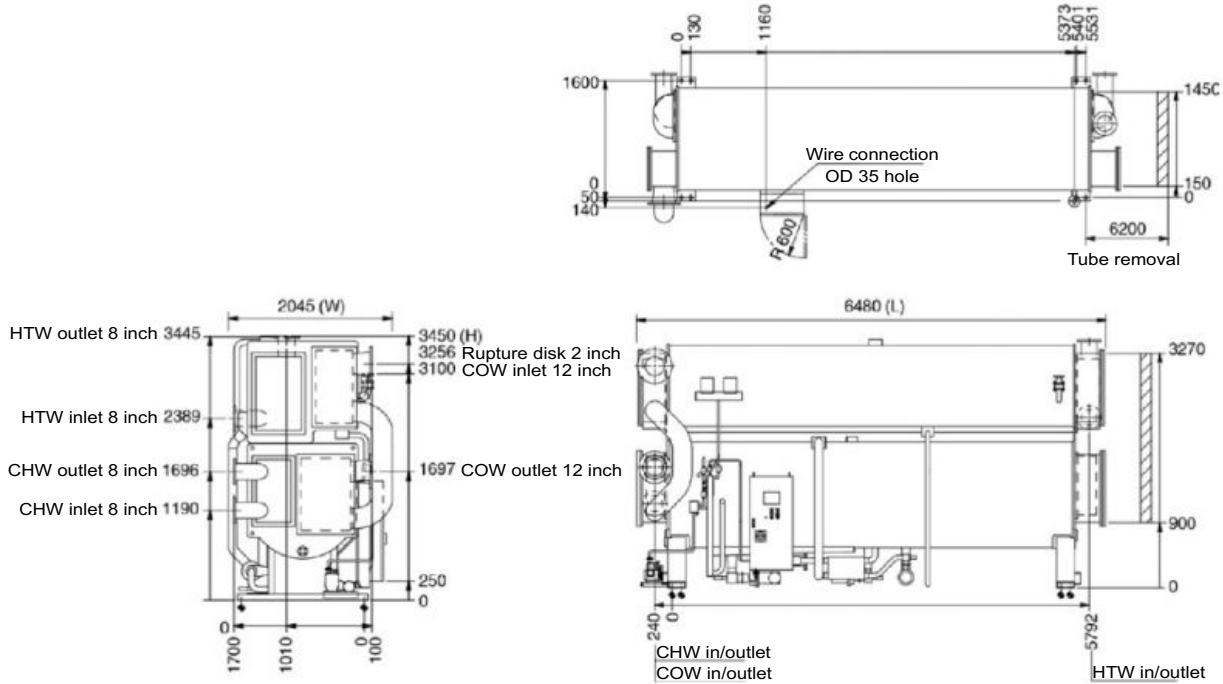

### 16LJ-F61

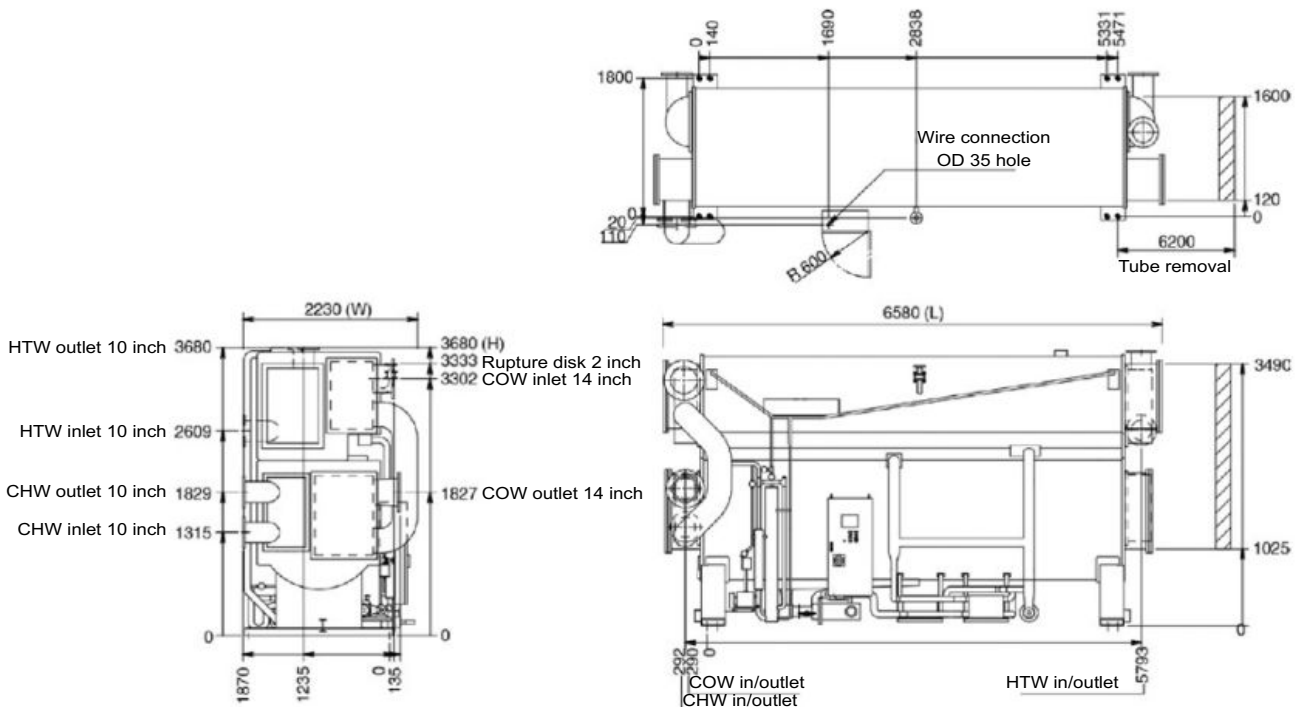

#### NOTES:

- (1) Dimensions (L), (W), (H), are for standard machine. The dimensions are changed by parts added.
- (2) indicates the position of anchor bolts.
- (3) Clearance space must be saved either side of the chiller.
- (4) Connecting flange of all external water piping are DIN 10 flange.
- (5) indicates the position of the power supply connection on control panel. (Dia. 35 mm).
- (6) Installation clearance
 

- Longitudinal distance	1000 mm
- Top	200 mm
- Others	500 mm

NOTE: Dimensions are for guidance only. Always refer to the certified drawings supplied upon request when designing an installation.

## DIMENSIONS/CLEARANCES

### 16LJ-F62

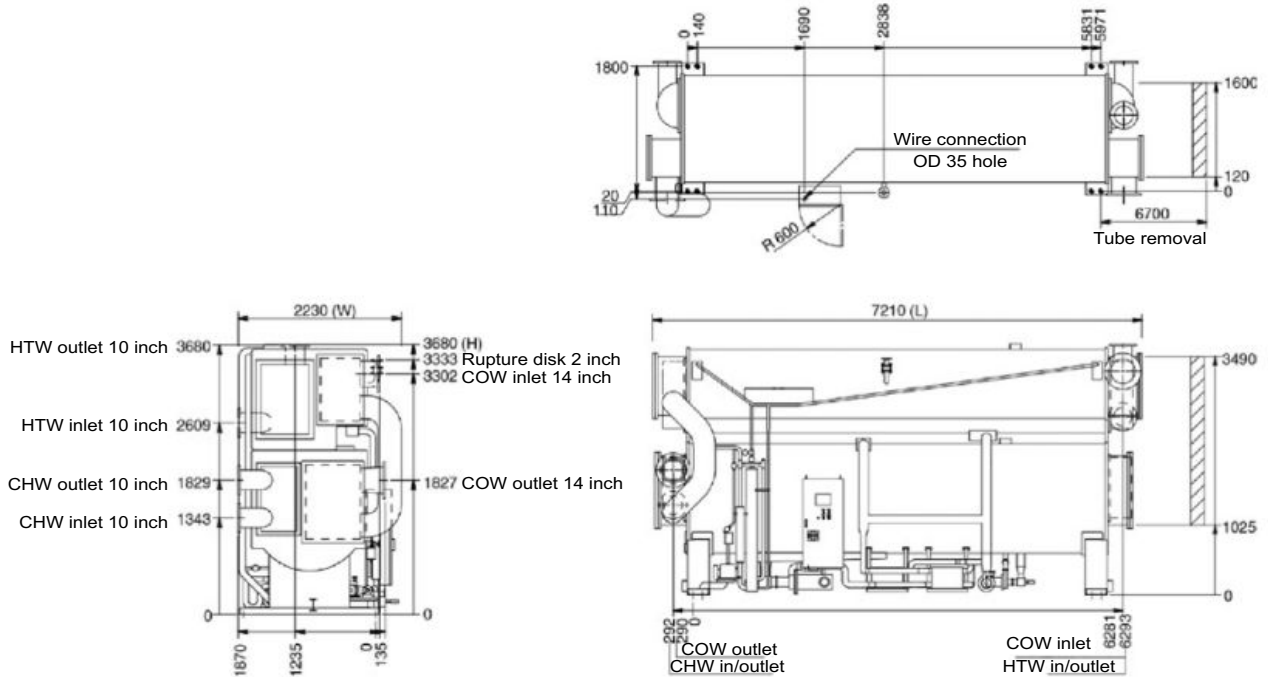

### 16LJ-F63

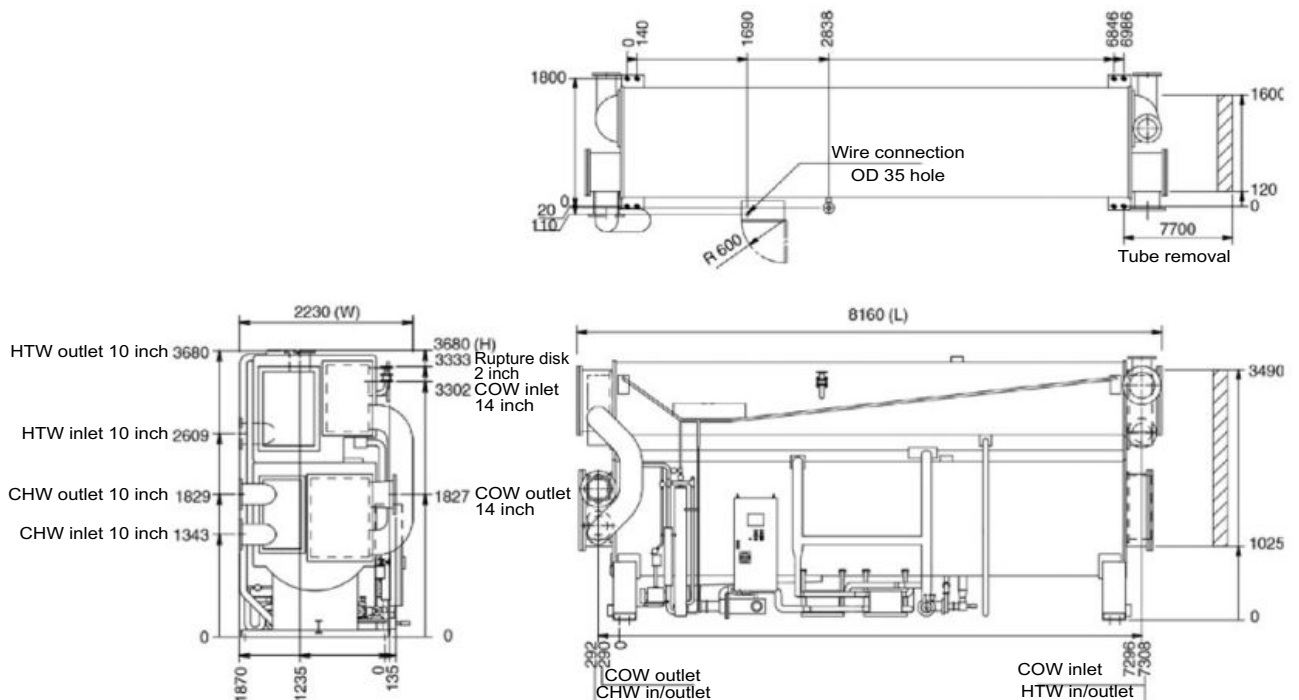

#### NOTES:

- (1) Dimensions (L), (W), (H), are for standard machine. The dimensions are changed by parts added.
- (2) indicates the position of anchor bolts.
- (3) Clearance space must be saved either side of the chiller.
- (4) Connecting flange of all external water piping are DIN 10 flange.
- (5) indicates the position of the power supply connection on control panel. (Dia. 35 mm).
- (6) Installation clearance
 

- Longitudinal distance	1000 mm
- Top	200 mm
- Others	500 mm

NOTE: Dimensions are for guidance only. Always refer to the certified drawings supplied upon request when designing an installation.

## DIMENSIONS/CLEARANCES

### 16LJ-F71

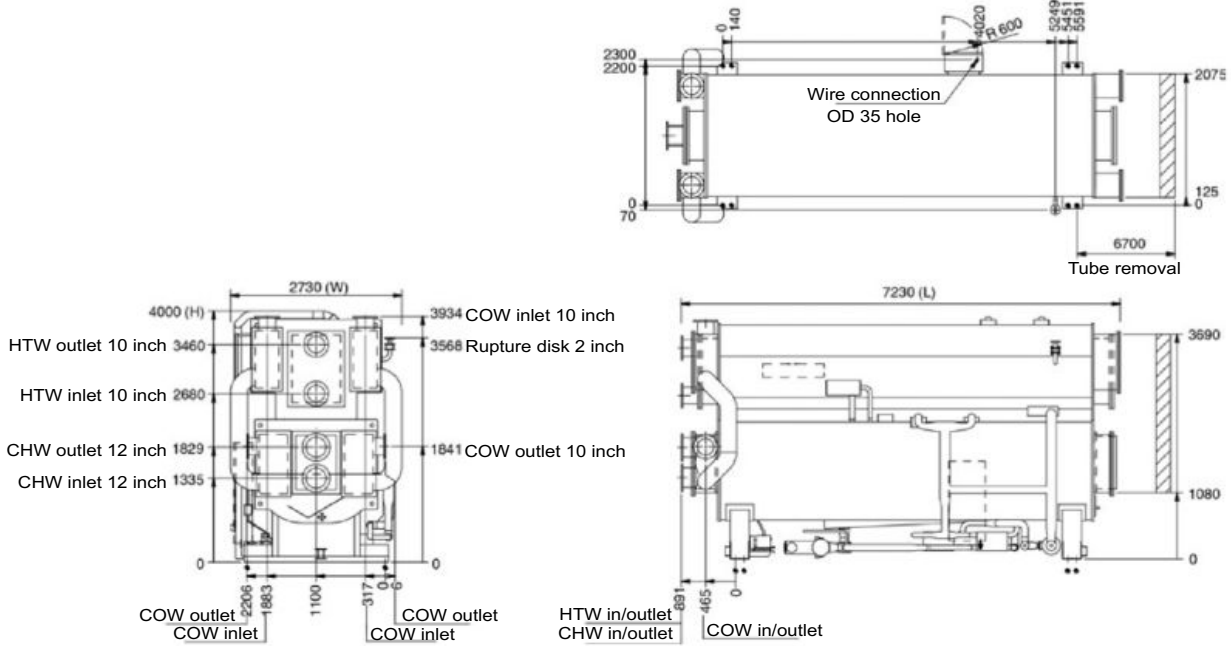

### 16LJ-F72/73

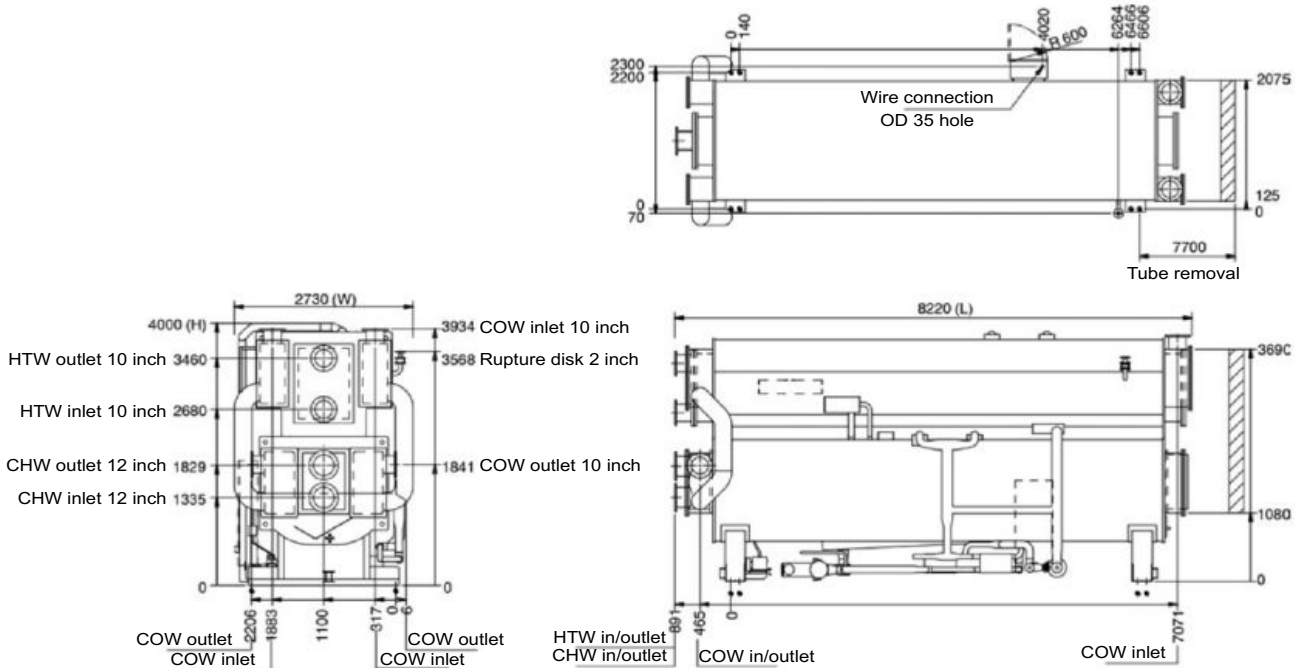

#### NOTES:

- (1) Dimensions (L), (W), (H), are for standard machine. The dimensions are changed by parts added.
- (2) indicates the position of anchor bolts.
- (3) Clearance space must be saved either side of the chiller.
- (4) Connecting flange of all external water piping are DIN 10 flange.
- (5) indicates the position of the power supply connection on control panel. (Dia. 35 mm).
- (6) Installation clearance
 

- Longitudinal distance	1000 mm
- Top	200 mm
- Others	500 mm

NOTE: Dimensions are for guidance only. Always refer to the certified drawings supplied upon request when designing an installation.

## DIMENSIONS/CLEARANCES

### 16LJ-F81/82

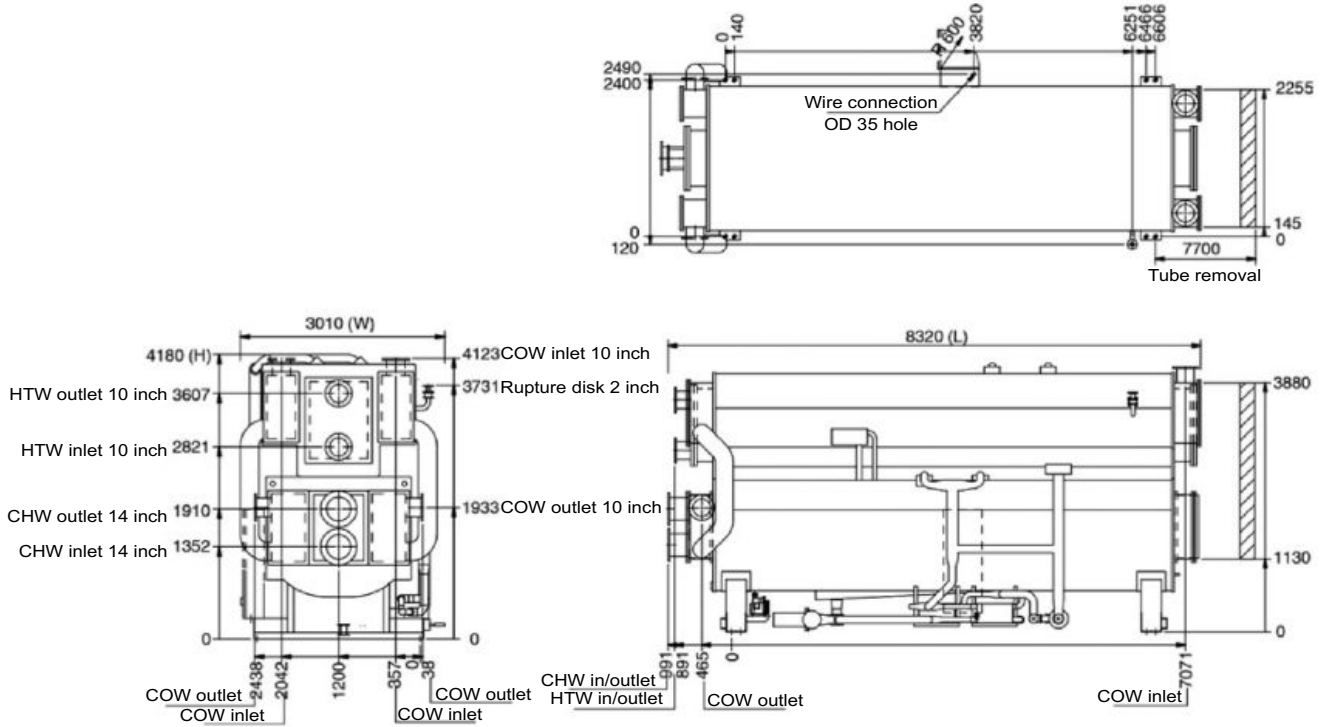

#### NOTES:

- (1) Dimensions (L), (W), (H), are for standard machine. The dimensions are changed by parts added.
- (2) indicates the position of anchor bolts.
- (3) Clearance space must be saved either side of the chiller.
- (4) Connecting flange of all external water piping are DIN 10 flange.
- (5) indicates the position of the power supply connection on control panel. (Dia. 35 mm).
- (6) Installation clearance
 

- Longitudinal distance	1000 mm
- Top	200 mm
- Others	500 mm

NOTE: Dimensions are for guidance only. Always refer to the certified drawings supplied upon request when designing an installation.

## FOUNDATION DIMENSIONS

Figure 4 - 16LJ-01

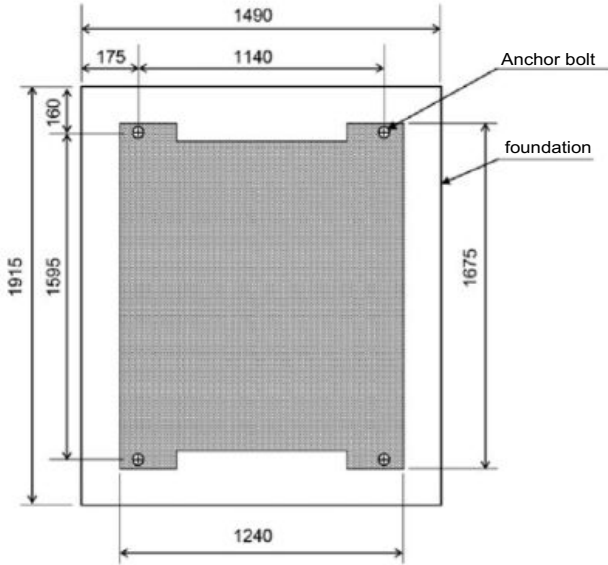

Figure 5 - 16LJ-02

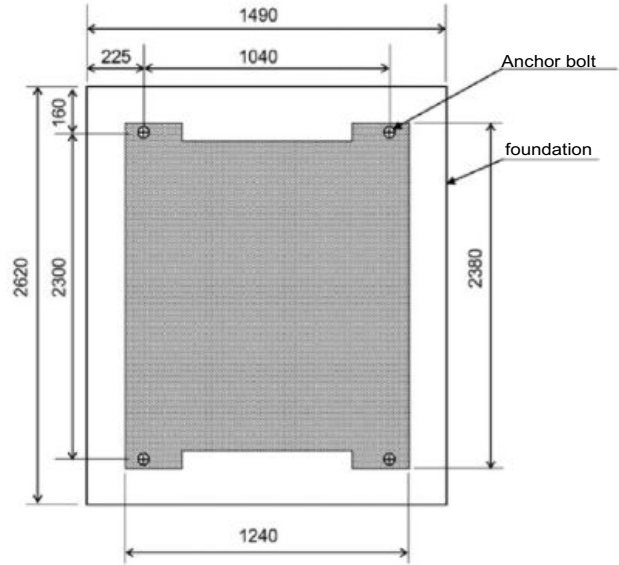
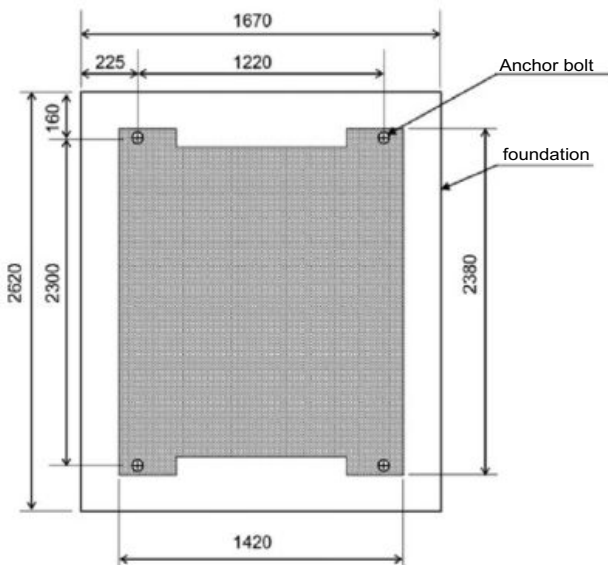
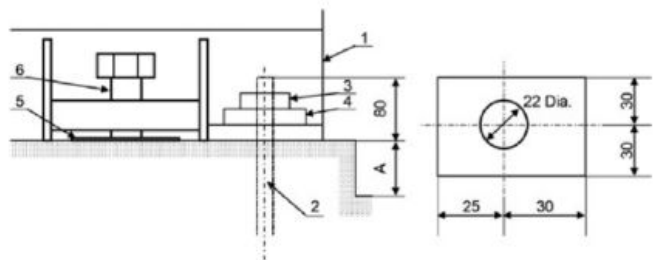

Figure 6 - 16LJ-03



Washer



**Legend :**

1. Base of the chiller
  2. Anchor bolt
  3. Nut
  4. Washer\*
  5. Plate
  6. Bolt for level adjustment\*
- \* Shipped with chiller

A = 200mm or more      Material : Steel  
Thickness : 9 mm

**NOTES**

1. indicates the machine base. The machine base has a 30 mm diameter hole for the anchor bolt.
2. The anchor bolt should be fixed as shown in the detail drawing.
3. There should be a drain channel around the foundation.
4. The floor surface should be made waterproof to facilitate maintenance work.
5. The surface of the foundation should be made flat (Leveling tolerance is 1 mm for 1000 mm)
6. Anchor bolts and nuts are to be supplied by the customer.



## FOUNDATION DIMENSIONS

Figure 7 - 16LJ-F11 to 16LJ-F42

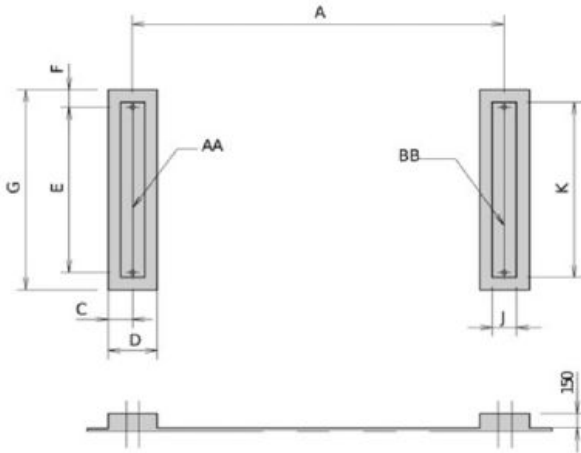

Figure 8 - 16LJ-F51 to 16LJ-F82

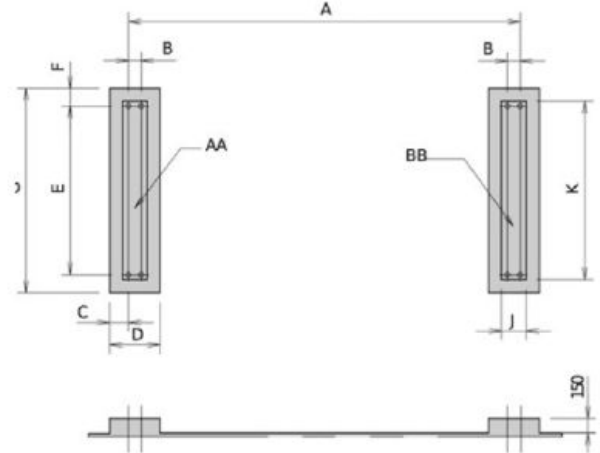
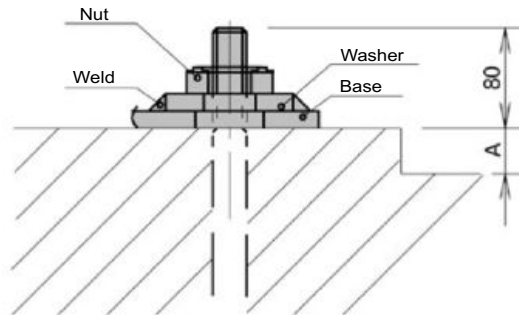

Figure 9 - Detail of base plate



A = 150 mm or more

### NOTES

1. indicates the machine base. The machine base has a 30 mm diameter hole for the anchor bolt.
2. The anchor bolt should be fixed as shown in the detail drawing.
3. There should be a drain channel around the foundation.
4. The floor surface should be made waterproof to facilitate maintenance work.
5. The surface of the foundation should be made flat (Leveling tolerance is 1 mm for 1000 mm)
6. Anchor bolts and nuts are to be supplied by the customer.

### 16LJ-F Foundation dimensions

Size	Weight (kg)			Dimensions (mm)								
	AA+BB	AA	BB	A	B	C	D	E	F	G	J	K
11	4100	2050	2050	1896	-	175	360	800	150	1100	160	900
12	4300	2150	2150	1896	-	175	360	800	150	1100	160	900
13	5300	2650	2650	2916	-	175	360	800	150	1100	160	900
14	5600	2800	2800	2916	-	175	360	800	150	1100	160	900
21	6900	3450	3450	2866	-	200	400	1000	150	1300	200	1100
22	7300	3650	3650	2866	-	200	400	1000	150	1300	200	1100
23	8400	4200	4200	3886	-	200	400	1000	150	1300	200	1100
24	8800	4400	4400	3886	-	200	400	1000	150	1300	200	1100
31	11000	5500	5500	4378	-	225	450	1100	150	1400	250	1200
32	11500	5750	5750	4378	-	225	450	1100	150	1400	250	1200
41	13800	6900	6900	4378	-	225	450	1150	150	1450	250	1250
42	14400	7200	7200	4378	-	225	450	1150	150	1450	250	1250
51	20200	10100	10100	4508	130	190	510	1600	180	1960	250	1700
52	21600	10800	10800	5006	130	190	510	1600	180	1960	250	1700
53	22800	11400	11400	5531	130	190	510	1600	180	1960	250	1700
61	28300	14150	14150	5471	140	220	580	1800	180	2160	320	1900
62	30100	15050	15050	5971	140	220	580	1800	180	2160	320	1900
63	33500	16750	16750	6986	140	220	580	1800	180	2160	320	1900
71	39100	19550	19550	5591	140	220	580	2200	180	2560	320	2300
72	42400	21200	21200	6606	140	220	580	2200	180	2560	320	2300
73	43700	21850	21850	6606	140	220	580	2200	180	2560	320	2300
81	46300	23150	23150	6606	140	220	580	2400	180	2760	320	2500
82	49200	24600	24600	6606	140	220	580	2400	180	2760	320	2500

## CONTROL PANEL DIMENSION (16LJ-01, 02, 03)

Figure 10 - Control panel

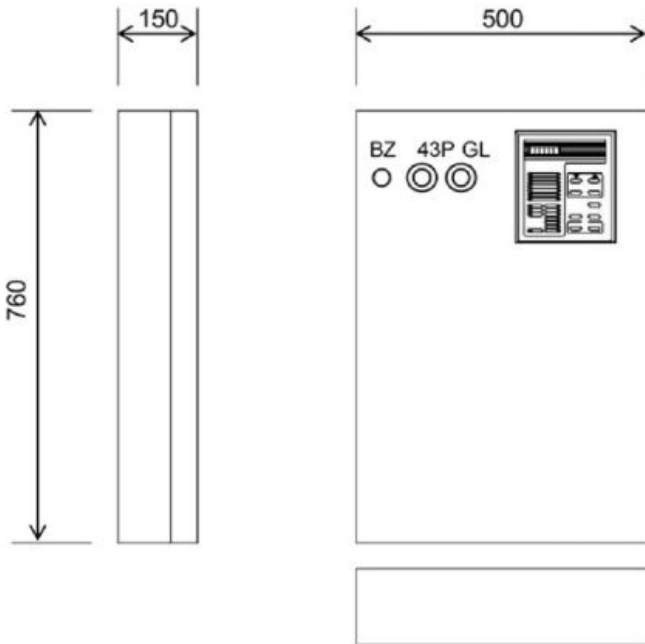

Thickness:      Body    2.0 mm  
                         Door    2.0 mm

Symbol	Name	Lamp color
BZ	Alarm buzzer	
GL	Purge indication lamp	Green
43P	Purge on-off switch	

Figure 11 - Display panel

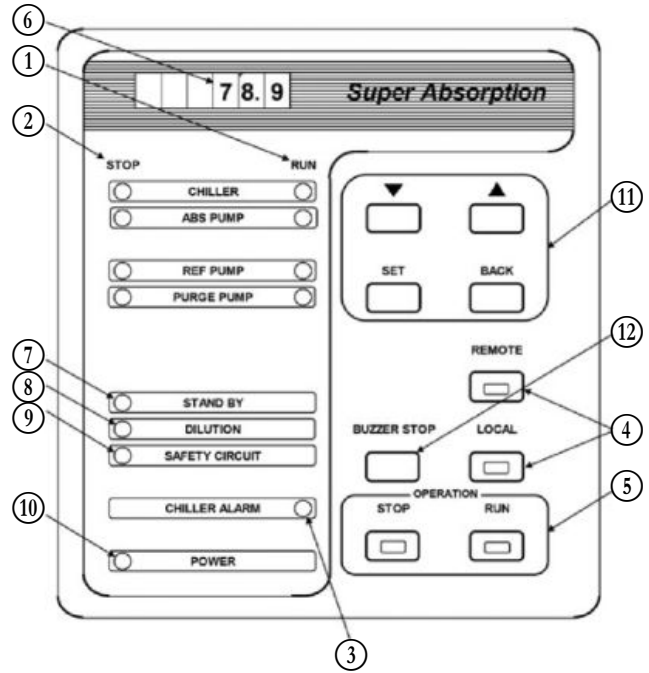

Number	Name	Lamp color
1	Operation indication lamp	Green
2	Stop indication lamp	Orange
3	Alarm indication lamp	Red
4	Remote/Local select key with lamp	Green
5	Operation select key with lamp	Green
6	Data display (7 segments)	LED
7	Stand by indication lamp	Green
8	Dilution indication lamp	Green
9	Safety circuit indication lamp	Green
10	Power indication lamp	Orange
11	Data select key	
12	Alarm buzzer stop key	

Figure 12 - Power panel

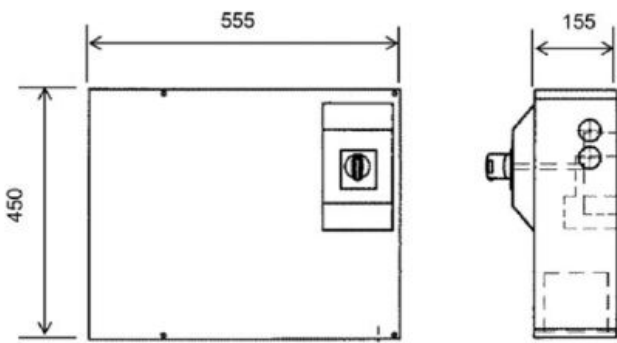

**CONTROL PANEL DIMENSION (16LJ-F)**

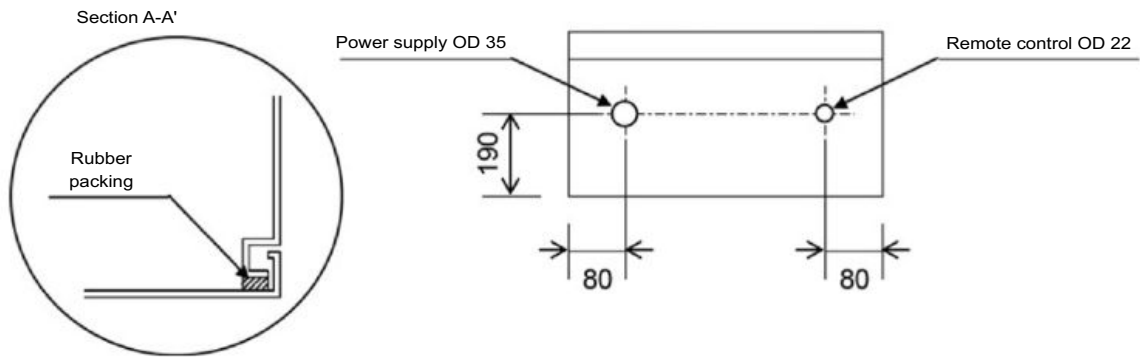
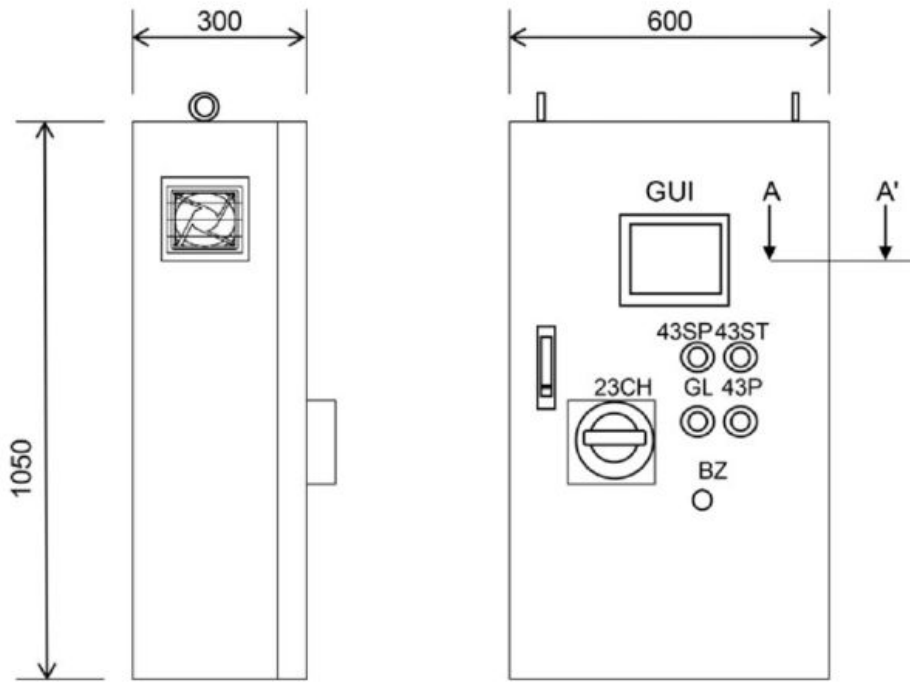

Thickness:	Body	2.0 mm
	Door	2.0 mm
	Mid plate	3.0 mm
Paint color	Munsell No. 5Y7/1	

Symbol	Name	Lamp color
GUI	Alarm buzzer	
43SP	Stop key and Stop indication lamp	Red
43ST	Run key and Run indication lamp	Green
GL	Local operation stand by lamp	Green
43P	Purge pump indication key	
BZ	Alarm buzzer	

## FIELD WIRING (16LJ-F)

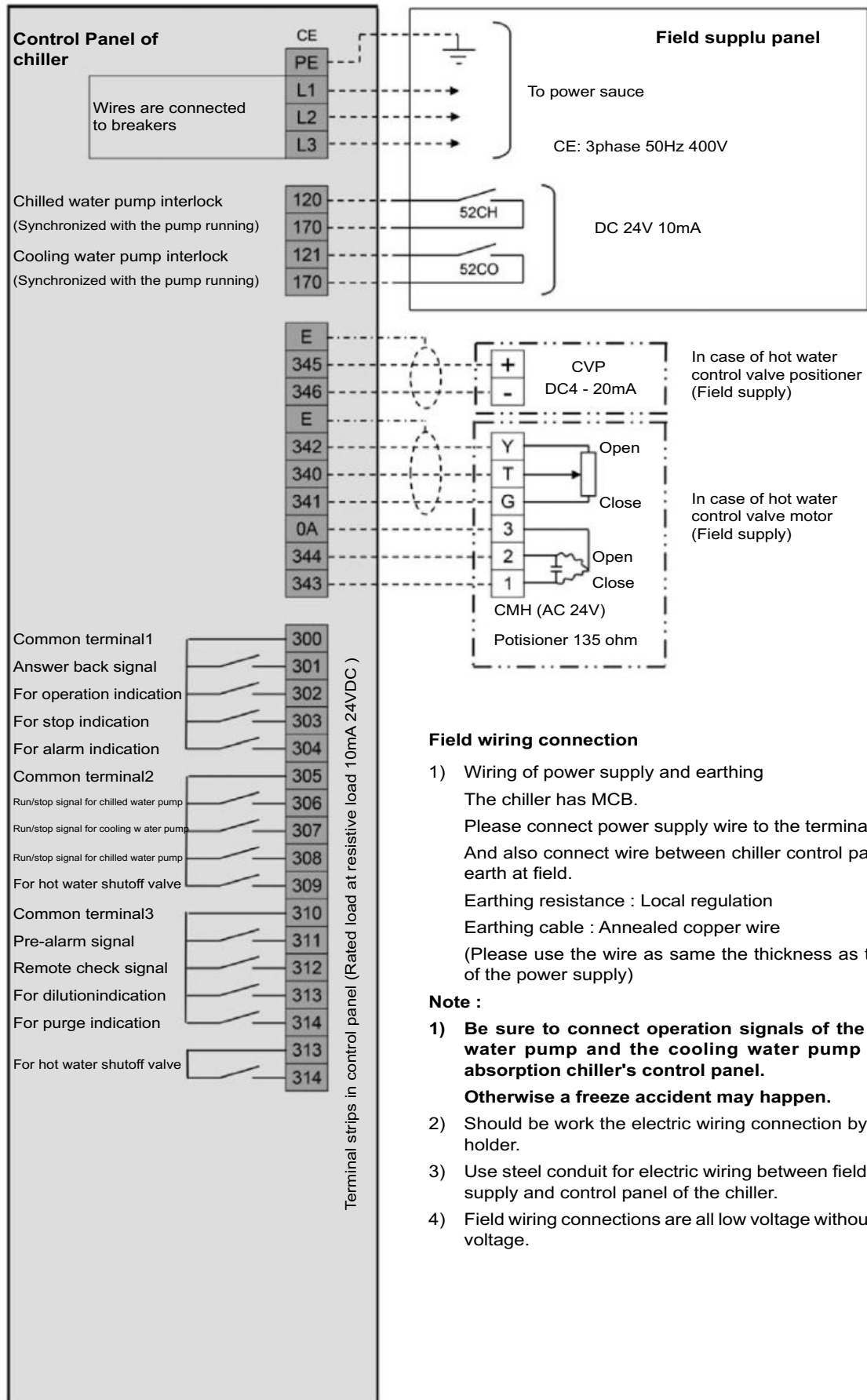

### Field wiring connection

- 1) Wiring of power supply and earthing  
The chiller has MCB.  
Please connect power supply wire to the terminal block.  
And also connect wire between chiller control panel and earth at field.  
Earthing resistance : Local regulation  
Earthing cable : Annealed copper wire  
(Please use the wire as same the thickness as the wire of the power supply)

### Note :

- 1) **Be sure to connect operation signals of the chilled water pump and the cooling water pump on the absorption chiller's control panel. Otherwise a freeze accident may happen.**
- 2) Should be work the electric wiring connection by license holder.
- 3) Use steel conduit for electric wiring between field electric supply and control panel of the chiller.
- 4) Field wiring connections are all low voltage without supply voltage.

## TYPICAL PIPING DIAGRAM

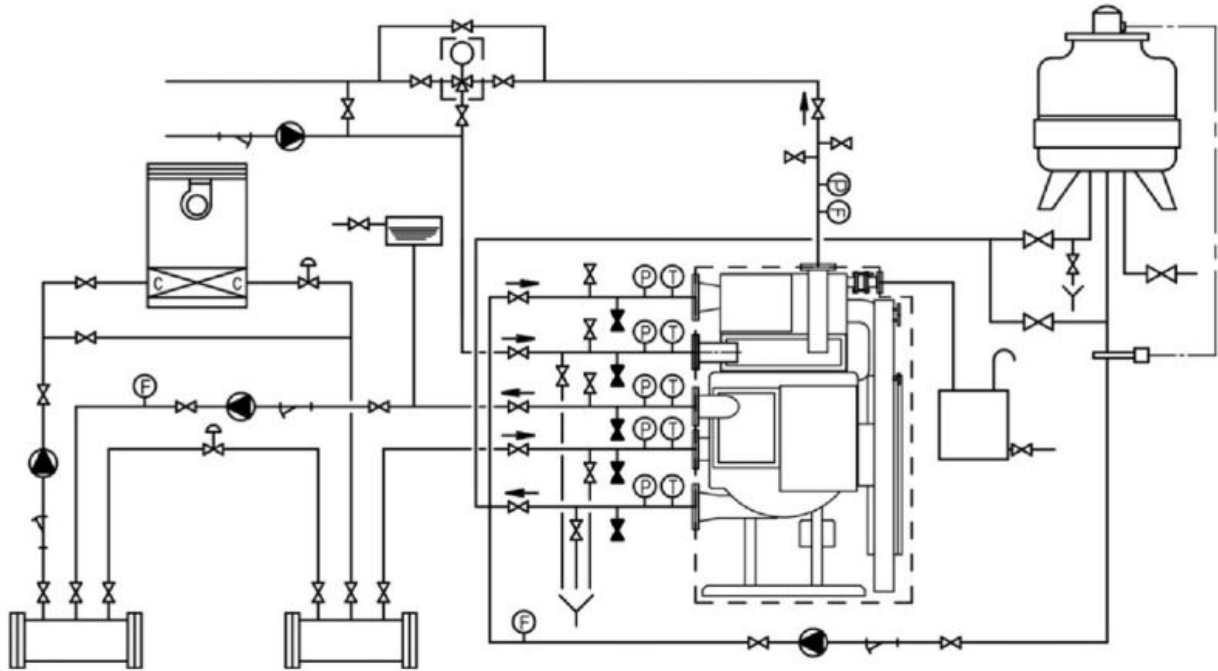

### Legend

- |                                  |                      |                                   |
|----------------------------------|----------------------|-----------------------------------|
| ① Cooling load                   | ⑦ Expansion tank     | ⑬ Make up water supply            |
| ② Chilled water pump (primary)   | ⑧ Hot water supply   | ⑭ Minimum tank capacity 1 m3      |
| ③ Chilled water pump (secondary) | ⑨ Cooling tower      | ⑮ Hot water return                |
| ④ Bypass valve                   | ⑩ Cooling water pump | ⑯ Hot water control 3 way valve   |
| ⑤ Supply header                  | ⑪ Blow down valve    | ⑰ To drain channel                |
| ⑥ Return header                  | ⑫ Bypass valve       |                                   |
| Ⓟ Thermometer                    | ⊕ Water pump         | ⊖ Connection for cleaning process |
| Ⓣ Pressure gauge                 | ⊗ Strainer           | ⊘ Thermostat                      |
| ⓕ Flow meter                     | ⊗ Manual valve       |                                   |

- Equipment and parts outside the area surrounded by the broken line are not supplied by Carrier.
- For pipe connections and diameter refer to the dimensional drawings and specification tables.
- Ensure that chilled water flow rate, cooling water flow rate are in conformity with the standard value. If the chilled water flow rate sinks to under 50% of the standard value, the chiller will stop. Please secure the chilled water's retention volume at least 11 liter / kW.
- Position the chilled water pump, cooling water pump, hot pump and expansion tank correctly so that the chiller pressure does not exceed the set value.
- For cooling water temperature control refer to the drawing "Cooling water temperature control method".
- Separate chilled, cooling and hot water pumps should be provided for each chiller.
- Provide a cooling water blow-down valve in the cooling tower inlet for water quality control.
- Install a filter in the chilled water, cooling water and hot water pipes (10 mesh).
- Install stop valves on the chilled, cooling and hot water inlet and outlet.
- Provide a thermometer and pressure gauge at the chilled, cooling and hot water inlet and outlet.
- Provide an air vent valve in each of the chilled, cooling and hot water line at point higher than the header.
- Install drain valves at the lowest positions between absorption chiller and the stop valves of the chilled water, cooling water and hot water, and pipe them to the drain channel.
- Provide an expansion tank at highest position in the chilled water line.
- Install a cooling tower away from any exhaust gas outlet.
- Connect the pipe from rupture disk to tank.
- Install stop valves between the absorption chiller and stop valves of all inlets and outlets for chemical cleaning of the water circuit system.
- When two way valve is used, there is the case that hot water outlet temperature is different from the specifications.



## GUIDE SPECIFICATIONS

Single-Effect Hot Water Absorption Chillers  
Size Range: 75 to 1125 Tons  
Carrier Model Number: 16LJ-F

### Part 1 — General

#### 1.01 SYSTEM DESCRIPTION

Electronically controlled, single effect (one-stage) absorption liquid chiller utilizing hermetic refrigerant and absorbent pumps, lithium bromide solution as the absorbent, and water as the refrigerant. Low temperature hot water shall be supplied to the generator as the heat source.

#### 1.02 QUALITY ASSURANCE

- A. Chiller performance shall be rated in accordance with ARI Standard 560-2000.
- B. Chiller shall be designed and constructed to meet applicable CE requirements and shall bear the CE marking.
- C. Each chiller shall undergo a series of standard factory tests to ensure that the unit is leak tight, that all electrical components operate as intended, and that every aspect of unit fabrication meets stringent quality standards in accordance with good practice and the manufacturer's quality assurance requirements.
  - 1. The shellside of each chiller shall be leak tested by pressurizing to 48 kPaG with nitrogen and then checked by spraying a soap and water mixture on all welds, tube joints and/or gasketed joints to identify any major leaks. Afterward, a mass spectrometer test shall be performed by evacuating the unit to 1 Pa absolute, cover-ing the machine with a vinyl tent and introducing helium gas under the tent. Any remaining leaks will allow the helium to be drawn into the shellside of the machine. The acceptable total leak rate as measured by the mass spectrometer test shall not exceed  $2.0 \times 10^{-7}$  Pa m<sup>3</sup> / sec .
  - 2. The tubeside of the evaporator, absorber, con-denser and generator shall be hydrostatically tested at 1.5 times rated design pressure and held for 1 hour.
  - 3. All machine wiring shall undergo an insulation resistance test. The machine control panel and all electrical components shall also be function-ally tested to verify continuity and proper electrical operation.
  - 4. Final assembly inspection shall consist of verifying that all valves, controls, instrumentation, pumps, purge components and all other machine components have been properly installed on the machine.
  - 5. Each unit shall be checked for overall appearance and dimensional accuracy.
  - 6. Final inspection shall be performed on each unit to check that the nameplate data is correct and that all accessories are furnished as required.

#### 1.03 DELIVERY, STORAGE, AND HANDLING

- A. Unit shall be stored and handled in accordance with the manufacturer's recommendations.
- B. Unit shall be factory-charged with lithium bromide solution if the machine is configured to ship in one piece. For shipments of multiple pieces, charging of lithium bromide solution shall be performed at the jobsite in accordance with the manufacturer's writ-ten instructions.
- C. All units shall be shipped with 20 kPaG nitrogen pressure.
- D. Chiller shall be shipped with nameplates indicating name of manufacturer, model size, serial number and all other pertinent machine data.

### Part 2 — Products

#### 2.01 EQUIPMENT

##### A. General:

Absorption liquid chiller shall include evaporator, absorber, condenser, generator, solution heat exchanger, refrigerant/ absorbent pumps, purge system, piping, wiring, controls and auxiliaries. Standard shipment of the machine shall be in one piece. Initial charge of lithium bromide shall be shipped inside the machine for all single-piece shipments. For multiple-piece shipments, initial charge of lithium bromide shall be shipped separately for charging at the jobsite. Generator shall be designed for operation on low temperature hot water as specified on the equipment schedule. A rupture disk shall be provided as standard on all machines.

##### B. Operating Characteristics:

- 1. Chiller operation shall be characteristic of a single - effect absorption cycle. The weak solution pumped from the absorber to the generator shall initially pass through a solution heat exchanger to improve operating efficiency by preheating the weak solution on the tube side with the strong solution returning from the generator on the shellside.
- 2. Unit shall be capable of continuous operation from 100 to 10% capacity, with entering condenser water temperatures as low as 18oC without the need for a cooling tower bypass valve. Thermostat on/off control of the cooling tower fan is recommended when cooling water temperature falls below 18oC.

##### C. Heat Exchangers:

- 1. All heat exchangers shall be of shell and tube construction with shells, tube sheets, tube support sheets and waterboxes fabricated of carbon steel. All heat exchangers shall incorporate straight tubes. Tube material for the generator and condenser shall be stainless steel. For the evaporator and absorber, tube material shall be copper. The evaporator, absorber, condenser and generator tubes shall be rolled into grooved tubesheets and expanded into tube support sheets, and shall be individually replaceable.
- 2. The evaporator, absorber and condenser water-boxes shall be designed for 1034 kPaG working pressure. The absorber and condenser water-boxes shall be hinged to permit access to all tubes from either end. Nozzle-in-head (NIH) type waterboxes shall be supplied on the evaporator while the absorber-condenser water-boxes shall be marine type. Waterboxes shall be provided with vent and drain connections. Epoxy painting of the waterboxes and tube sheets shall be provided for corrosion protection. DIN PN10 flanges shall be furnished on all waterbox nozzle connections.

## GUIDE SPECIFICATIONS

3. The generator tube side shall be designed for 1034 kPaG working pressure for use with low temperature hot water.
4. A solution heat exchanger shall be an integral part of the machine to increase cycle efficiency by preheating the weak solution on its way to the generator while pre-cooling the strong solution returning from the generator.
5. Dispersion trays shall evenly distribute refrigerant over the evaporator tubes and lithium bromide over the absorber tubes. These trays shall be fabricated of stainless steel to ensure continuous, corrosion-free, high-efficiency operation.
6. Generator structure shall be falling file type.

### D. Pump/Motors:

Refrigerant and absorbent pump/motor assemblies shall be of the self contained, leakproof, hermetic type, without an external seal water system to minimize air leakage into the machine. Lubrication and cooling shall be accomplished by the fluid being pumped; auxiliary water piping for cooling and lubrication shall not be acceptable. Each pump casing shall be welded into the piping at the factory and shall be furnished with isolation valves on the suction and discharge side. Each pump shall include spring-loaded, wear-compensating tapered carbon bearings to ensure long life and reliability. Pump/motor assemblies shall be designed for 25,000 hours of normal operation between inspections.

### E. Purge System:

An automatic purge system shall be furnished to provide a continuous purging action whenever the chiller is in operation to assure long machine life and efficient performance. Noncondensables shall be removed from the absorber by a liquid eductor, which shall use flow from the absorbent pump to create a suction. Noncondensables shall be stored external to the unit and shall be prevented from diffusing back into the machine when the unit is not operating. A palladium cell shall be provided to automatically vent hydrogen gas from the purge chamber to the atmosphere. It shall be continuously energized, even during machine shutdown. Further evacuation of the external storage chamber shall be accomplished with a factory-mounted purge pump, piped and wired to the machine. The need to operate the purge pump shall be indicated on the front of the control panel.

### F. Controls, Safeties and Diagnostics:

1. Controls:
  - a. The chiller shall be provided with a factory-installed and factory-wired microprocessor control system with modular component construction. The controls shall be of the PID type and shall continuously monitor the operation of the chiller and perform self-diagnostic checks to ensure that all control limits are satisfied and maintained. The system shall include a control center, power supply, temperature sensors, pressure sensors and all necessary auxiliary devices required for safe and proper chiller operation housed in a NEMA-1 enclosure with a hinged, lockable door. Control power shall be AC24V, Single-phase, 50Hz.  
  
The chiller control system shall have the ability to interface and communicate with a building management system through Modbus protocol as standard, BACnet as option.  
  
The control system shall include Touch Screen GUI (Graphical User Interface), PLC, functional keys, emergency stop button (connected to a circuit breaker) and indication lamps and an alarm buzzer. Touch screen GUI shall be configurable to display either English or metric units.

- b. The control panel touch screen shall allow an operator to easily set and display the operating mode and configurable settings of the machine. The display shall indicate chiller run status, alarm status, remote/local operation, standby mode and dilution cycle operation. Data input and machine settings shall be done via a touch screen and shall allow scrolling through the individual chiller parameter settings.
- c. Monitoring the operation of the chiller shall be done on a continuous basis. The touch screen GUI shall indicate all pertinent system operating parameters and alarms, as necessary, including the following:
  - 1) Chiller operating hours.
  - 2) Chilled water inlet temperature.
  - 3) Chilled water outlet temperature.
  - 4) Chilled water temperature set point.
  - 5) Cooling water inlet temperature.
  - 6) Condenser temperature.
  - 7) Generator temperature.
  - 8) Hot water inlet temperature.
  - 9) Hot water outlet temperature.
  - 10) Absorbent pump No. 1 start counter and operating hours.
  - 11) Absorbent pump No.2 start counter and operating hours.
  - 12) Refrigerant pump start counter and operating hours.
  - 13) Purge pump start counter and operating hours.
  - 14) Chiller start counter.
  - 15) Purge tank pressure.
- d. Capacity control shall be by means of electronically modulating the hot water control valve to maintain the temperature of the chilled water. Load modulation shall be from 100% to 10% of machine full load under normal ARI conditions. The hot water control valve shall be positioned by a PID control algorithm to ensure precise control of desired chilled water temperature without hunting or overshooting the set point.
- e. The microprocessor control system shall include a programmed sequence to ensure machine readiness prior to machine start-up. The microprocessor shall automatically enable and interlock the chilled water pump, cooling water pump and cooling tower fans upon chiller activation.
- f. Upon request to start the chiller, the control system shall start the chilled water pump and verify chilled water flow. The controller shall then start the cooling water pump and verify interlock signal, before starting tower fan(s), absorbent pump No.1, absorbent pump No.2 and refrigerant pump.
- g. The control system shall automatically sense impending abnormalities in the absorption operating cycle and take the following actions to either self-correct and/or limit the machine from approaching cycle crystallization line:
  - 1) Close hot water control valve for a set period.
  - 2) Stop the operation of the machine after performing a dilution cycle if the solution concentration is still over the pre-set level.
- h. The rate at which the hot water control valve is opened shall be precisely controlled.

## GUIDE SPECIFICATIONS

- i. The control system shall automatically cycle the refrigerant pump whenever the leaving chilled water temperature falls below the desired set point. The chilled water pump shall remain on and when the leaving chilled water temperature rises above the set point, the refrigerant pump shall automatically restart.
  - j. The control center shall allow reset of the chilled water temperature set point based upon any one of the following criteria:
    - 1) Chilled water reset based on an external 4 to 20 mA signal.
    - 2) Chilled water reset based on cooling water inlet temperature.
  - k. When the stop button is pressed or remote contacts open the control center shall immediately drive the hot water control valve to the closed position and initiate the normal shutdown sequence including dilution cycle. The display shall indicate that the machine is in the dilution cycle.
2. Safeties:
- a. Unit shall automatically shut down when any of the following conditions occur. In addition, the chiller goes into alarm mode and indicates the reason for the shutdown on the chiller data display.
    - 1) Absorbent pump No.1 motor overload.
    - 2) Absorbent pump No.2 motor overload
    - 3) Refrigerant pump motor overload.
    - 4) Purge pump motor overload.
    - 5) Low chilled water temperature.
    - 6) Low cooling water temperature.
    - 7) Generator high temperature.
    - 8) Loss of chilled water flow.
    - 9) (Optional) loss of cooling water flow.
    - 10) Loss of chilled water pump interlock.
    - 11) Loss of cooling water pump interlock.
    - 12) High solution concentration.
  - b. The control system shall detect conditions that approach protective limits and take self-corrective action prior to an alarm occurring. The system shall automatically reduce chiller capacity when any of the following parameters are outside their normal operating range:
    - 1) Low cooling water inlet temperature.
    - 2) High cooling water inlet temperature.
    - 3) High solution concentration.
3. Diagnostics and Service:
- a. The chiller control system shall execute a series of self-diagnostic checks whenever power is first turned on to determine if temperatures are within pre-start limits, thereby allowing start-up to proceed. If any of the limits are exceeded, an alert message will be displayed, informing the operator of the cause of the pre-start alert.
  - b. The control system shall provide an alarm display on the front of the panel for any sensor that has failed. These sensors include:
    - 1) Chilled water inlet temperature.
    - 2) Chilled water outlet temperature.
    - 3) Cooling water inlet temperature.
    - 4) Cooling water outlet temperature.
    - 5) Cooling water intermediate temperature.
    - 6) Hot water inlet temperature.
    - 7) Hot water outlet temperature.
    - 8) Condenser temperature.
    - 9) Refrigerant temperature.
    - 10) Diluted solution temperature.
    - 11) Generator temperature.
    - 12) Purge tank pressure.
  - c. The chiller controls shall display maintenance messages and alarms when efficient operation of the chiller is in jeopardy or when immediate attention is necessary. When operating conditions are predicted to be problematic, the following messages shall be displayed on the panel:
    - 1) Purge tank high pressure.
    - 2) Cooling water tubes excessive fouling.
    - 3) Cooling water high temperature.
    - 4) Power failure.
4. Building Control System Interface:
- The chiller control system shall have the ability to interface and communicate directly to the building control system through Modbus as standard, BACnet as option without additional field-installed hardware and software.
- G. Electrical Requirements:**
1. Power supply to the unit shall be 3 ph, 50 Hz with voltages of 400 as specified on the equipment schedule. A control transformer shall provide 24-volt single-phase secondary power for the control panel.
  2. Contractor/owner shall supply and install the electrical power line and all auxiliary electrical protection devices per local code requirements and as indicated necessary by the chiller manufacturer.
  3. Contractor/owner shall supply and install electrical wiring and devices required to interface the chiller controls with the building controls system if applicable.
- H. Piping Requirements:**
1. Piping and instrumentation for the chilled water, cooling water and hot water shall be supplied and installed by the contractor/owner.
  2. Absorber-condenser crossover piping shall be furnished by the chiller manufacturer.
  3. Cooling water flow switch shall be supplied by either the chiller manufacturer or the contractor/owner.
  4. Piping from the rupture disk shall be provided and installed by the contractor/owner and piped in accordance with the chiller manufacturer's written instructions and any local jurisdictional requirements.

## GUIDE SPECIFICATIONS

### I. Thermal Insulation:

Insulation of the evaporator, refrigerant pump, sump, piping and chilled water headers, in addition to any hot surfaces shall be field supplied and installed on the machine. Chiller manufacturer shall recommend the material and specify surface area to be insulated.

### J. Sound Level:

The overall sound pressure level of the chiller shall not exceed 80 dbA when measured per ARI Standard 575-1994.

### K. Start-up:

1. Unit manufacturer shall provide a factory-trained service representative, employed by the chiller manufacturer, to perform and/or super-visit chiller pressure test (when required), charge chiller with refrigerant (water) and lithium bromide solution, place unit into operation, and calibrate all controls in accordance with the manufacturer's written start-up, operating and maintenance instructions.
2. After unit start-up has been performed, the same factory representative shall be available for a period of instruction not to exceed 4 hours to instruct the owner's personnel in the proper start-up, operating and maintenance procedures.
3. Manufacturer shall provide the following documentation and literature:
  - a. Installation Instructions.
  - b. Start-Up, Operating and Maintenance Instructions.
  - c. Dimensional Drawing.
  - d. Foundation Drawing.
  - e. Field Wiring Diagram.

### L. Options and Accessories:

1. Marine Waterboxes:  
Marine waterboxes with removable covers to facilitate tube cleaning and maintenance shall be furnished when specified on the equipment schedule.
2. High-Pressure Waterboxes:  
Waterboxes rated for 2000 kPaG working pressure with removable covers shall be furnished when specified on the equipment schedule.
3. Special Tubing:  
Tubing of non-standard materials, geometry or wall thickness shall be provided when specified on the equipment schedule.
4. Shipping Configuration:  
Chiller shall ship either fully assembled or in multiple pieces as specified on the equipment schedule.
5. Victaulic Nozzle Connections:  
Victaulic grooves shall be provided on all water-box nozzle connections when specified on the equipment schedule.
6. Cooling Water Flow Switch:  
Cooling water flow switch, rated for either 1034 kPaG or 2000 kPaG, shall be factory supplied when specified on the equipment schedule.
7. Isolation Package:  
A vibration isolation package consisting of neoprene isolation pads shall be furnished when specified on the equipment

## SAFETY CONSIDERATIONS

---

### Before operating the unit

- Before operating the unit be sure to read the operation manual carefully.
- Installation should conform to all applicable local codes and regulations.

### During the installation

- Read the installation manual carefully before offloading and installing the unit.
- All work must be carried out by qualified personnel to prevent injuries and damage to the equipment.
- Waterproof the unit foundation and provide a drain channel to prevent water damage to the surrounding equipment.
- Provide adequate space around the unit for maintenance work to ensure safe working conditions.

### Maintenance

- In addition to daily inspection periodical maintenance is required. Insufficient or incorrect maintenance may cause fire, electric shock and injuries.
- Please consult your local service office for further guidance.

### Avoiding hazardous places

- Keep the units away from dangerous inflammable substances such as gasoline, thinner and combustible gases, as these may result in a fire.





## DOUBLE-EFFECT STEAM-FIRED ABSORPTION CHILLERS



SUPER ABSORPTION

# 16NK

Nominal cooling capacity 345 to 4652 kW

Eighteen sizes with nominal cooling capacities from 345 to 4652 kW.

The 16NK absorption chillers are designed for cooling applications where low-pressure steam is available as waste heat.

Minimises global warming effect by greatly reducing power consumption and eliminating the generation of greenhouse gases.

Allows diversification of critical cooling requirements. Critical cooling loads are met with minimal electrical power input.

Allows use of smaller emergency generators since the electrical load associated with an absorption chiller is minimal.

## PHYSICAL DATA

16NK		11	12	13	21	22	31	32	41	42
<b>Cooling capacity</b>	kW	345	447	549	689	861	1034	1238	1378	1551
<b>Chilled water system*</b>										
Flow rate	l/s	14.8	19.2	23.6	29.7	37.2	44.4	53.3	59.4	66.7
Pressure drop	kPa	44	64	64	57	42	41	49	46	41
Connection (ANSI)	in	4	4	4	5	6	6	6	8	8
Retention volume	m <sup>3</sup>	0.13	0.15	0.17	0.24	0.28	0.34	0.36	0.46	0.48
<b>Cooling water system*</b>										
Flow rate	l/s	24.7	31.9	39.4	49.4	61.9	74.2	88.9	98.9	111.4
Pressure drop	kPa	68	40	49	109	74	53	65	67	73
Connection (ANSI)	in	5	5	5	6	8	8	8	10	10
Retention volume	m <sup>3</sup>	0.34	0.38	0.42	0.58	0.63	0.89	0.95	1.11	1.9
<b>Steam system</b>										
Saturated steam 784 kPa										
Consumption	kg/h	400	510	630	790	980	1180	1410	1570	1770
<b>Dimensions</b>										
mm										
Length A		2810	3850	3850	3880	4920	5040	5040	5100	5100
Height B		2200	2200	2200	2250	2250	2390	2390	2600	2600
Width C		2050	1910	1910	2240	2070	2170	2170	2400	2400
<b>Operating weight</b>	kg	4600	5800	6100	7500	8800	11200	11800	13900	14500
<b>Power supply</b>										
V-ph-Hz										
400-3-50										
Total current drawn	A	10.8	10.8	10.8	13.3	13.3	13.6	13.6	20.7	20.7

16NK		51	52	53	61	62	63	71	72	81
<b>Cooling capacity</b>	kW	1723	1927	2170	2412	2757	3101	3446	3963	4652
<b>Chilled water system*</b>										
Flow rate	l/s	74.2	83.1	93.9	103.9	118.6	133.6	148.3	170.6	200.3
Pressure drop	kPa	98	46	61	123	83	78	54	81	84
Connection (ANSI)	in	8	8	8	10	10	10	12	12	14
Retention volume	m <sup>3</sup>	0.65	0.71	0.77	0.99	1.06	1.13	1.41	1.61	1.94
<b>Cooling water system*</b>										
Flow rate	l/s	123.6	138.3	155.6	173.1	197.8	222.5	247.2	284.4	333.9
Pressure drop	kPa	53	71	94	61	83	111	77	113	122
Connection (ANSI)	in	12	12	12	14	14	14	16	16	16
Retention volume	m <sup>3</sup>	1.87	2.01	2.14	2.79	2.97	3.15	3.67	4.11	4.76
<b>Steam system</b>										
Saturated steam 784 kPa										
Consumption	kg/h	1960	2200	2470	2750	3140	3530	3920	4510	5300
<b>Dimensions</b>										
mm										
Length A		5330	5870	6370	6100	6190	6710	6440	7460	7460
Height B		2900	2900	2900	3330	3330	3330	3450	3450	3650
Width C		2770	2800	2800	2970	3000	3000	3300	3300	3500
<b>Operating weight</b>	kg	18800	20800	22300	26500	30000	32100	38000	42300	47300
<b>Power supply</b>										
V-ph-Hz										
400-3-50										
Total current drawn	A	22.7	24.5	24.5	25.5	25	25	33.5	33.5	33.5

Cooling per ARI 560 2000:

\* 12.2 → 6.7°C (fouling factor = 0.0176 m<sup>2</sup> K/kW)

\*\* 29.4 → 35.4°C (fouling factor = 0.044 m<sup>2</sup> K/kW)

## FEATURES AND ADVANTAGES

- Eighteen sizes with nominal cooling capacities from 345 to 4652 kW.
- The 16NK absorption chillers are designed for cooling applications where low-pressure steam is available as waste heat.
- Can tie into district steam systems.
- Allows diversification of critical cooling requirements. Critical cooling loads are met with minimal electrical power input.
- Allows use of smaller emergency generators since the electrical load associated with an absorption chiller is minimal.
- Environmentally balanced and CFC-free.
- Minimises global warming effect by greatly reducing power consumption and eliminating the generation of greenhouse gases.
- Reduced noise and vibration levels. The absorption chiller does not use a large motor-compressor, leading to quiet, vibration-free operation.
- Small footprint. The high efficiency associated with double-effect chillers results in a reduction of the required installation space.
- Auto-diagnosis system monitors operating conditions, predicts chiller information and maintains stable operation.
- Advanced high-precision control system.
- Absorption pump with inverter control for efficient, energy-saving operation.
- High-performance purge system minimises maintenance requirements.
- State-of-the-art protection devices guarantee enhanced operating safety.

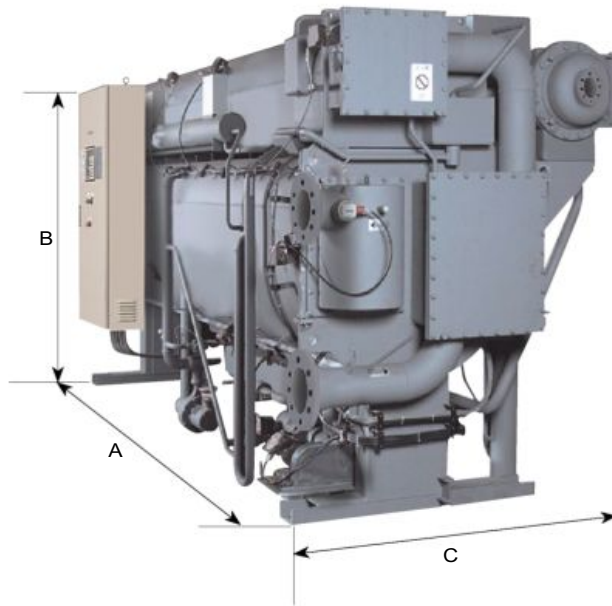

## CONTROLS

Display and control board

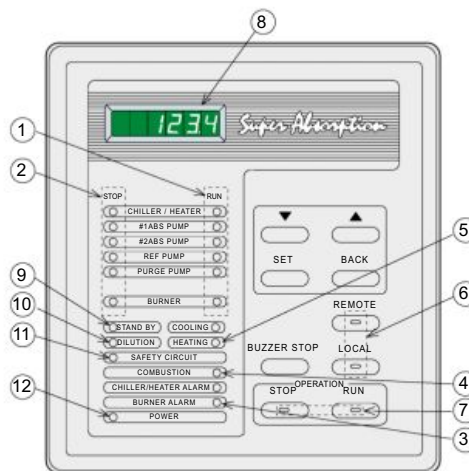

- |   |                            |                            |    |                           |     |
|---|----------------------------|----------------------------|----|---------------------------|-----|
| 1 | Operation indication       | Red                        | 7  | Operation mode selection  | Red |
| 2 | Stop indication            | Red                        | 8  | Data display              | Red |
| 3 | Alarm indication           | Red                        | 9  | Stand-by indication       | Red |
| 4 | Combustion indication      | Red                        | 10 | Dilution indication       | Red |
| 5 | Cooling/Heating indication | Red                        | 11 | Safety circuit indication | Red |
| 6 | Remote/local select button | Red                        | 12 | Power indication          | Red |
|   | 5                          | Cooling/Heating indication |    | Or green                  |     |
|   |                            | Remote/local select button |    | Red                       |     |
|   |                            | operation indicator lamp   |    | Red                       |     |





## DRY COOLERS



Performance  
Flexibility  
Intelligence  
Energy optimisation  
Acoustic optimisation

## 09PE

From 10 to 1100 kW

The 09PE range is particularly suited to tertiary, industrial and healthcare applications. Dry coolers in the 09PE range are mainly designed for cooling water or glycol/water mix for:

- Condensers for water chillers,
- Free cooling,

These devices are designed to be installed outdoors.

## DESCRIPTION

### Excellent resistance to corrosion

The casing offers 480 hours of resistance in salt spray tests in accordance with ISO 9227, C3 corrosion class Long durability in excess of 15 years or C4 Intermediate durability between 5 and 15 years, in line with ISO standard 12944-2



- ① **Coil**  
Copper tubing and manifolds, high-performance aluminium fins, resistant to fouling.  
Anti-shear system for bundle tubing.  
Piping: ISO PN16 02A type rotating flanges as per DIN 2642 in 304L stainless steel (1 or 2 inlets/outlets depending on flow rate).
- ② **Fan motor assemblies**  
Profiled collars in galvanised steel with RAL7035 polyester powder paint or RAL9005 composite depending on the motor reference.  
Aluminium and polypropylene impeller.  
Class F motor - IP54 - three-phase 400 V +/-10 % 50 Hz +/-2 %.  
Black protective grille compliant with standard NF ISO 12499.  
Individual partitioning.  
EC motors can be used in 50 or 60 Hz and from 380 to 480V +/- 10%.
- ③ **Casing**  
Galvanised steel with polyester powder paint. Assembly using stainless rivets and LANTHANUM nuts and bolts for the feet.
- ④ **Feet**  
Galvanised steel with polyester powder paint.
- ⑤ **Protective enclosures on the elbows and manifolds**

Each device is tested:

- The coil sealing is subjected to an underwater airtightness test.
- For devices with the terminal strip or electrical cabinet option: rotation tests, dielectric tests, current measurement.

The 09PE range complies with the following European directives:

- Machinery directive 2006/42/EC,
- EMC directive 2014/30/EU,
- Pressure Equipment Directive (PED) 2014/68 EU.

## RANGE

09PE is a large modular range, which offers:

- 3 casing lengths (S, M or L module), allowing either the dimensions, the capacity or the power consumption to be optimised.
- A range of sizes, from 1 to 14 fans.
- 2 impeller diameters, 800 or 910 mm.
- Adaptation of the rotation speed (EC motor).
- Configuration: horizontal or vertical unit.

Various combinations of these elements, as well as the choice of a number of options, allow us to provide devices that are adapted to a range of applications and environments.

## DESCRIPTION

### 09PE DLN 9 12 4-2 SHI 690E 9A

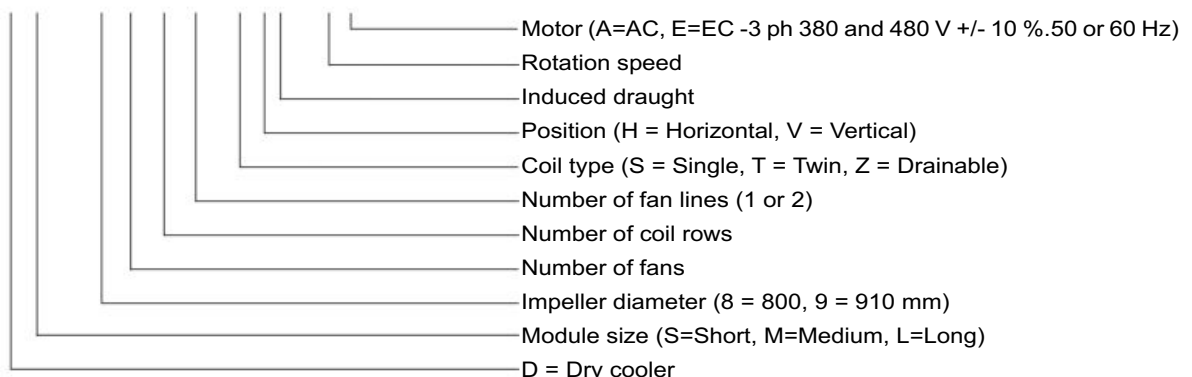

## OPTIONS FOR EACH APPLICATION

	Options	Description/Advantages
<b>Protection adapted for the environment</b>	Pre-coated aluminium fins	Improves the resistance of the fins to corrosion. For applications in coastal areas, industrial areas or highly populated areas.
	High-efficiency coating on fins: ALUCCOAT®507/HERESITE (on request)	Improves the resistance of the fins to corrosion. For corrosive environments.
	Corrosiveness resistance category C5M	Casing and fan motor assemblies for corrosive environments.
<b>Quick, simple installation</b>	Terminal box	Connection to the terminals of each motor on the front panel of the device.
	Protection cabinet	Protected by a thermal-magnetic circuit breaker on each motor.
	Control cabinet	Motor and control protection, either by electronic board, depending on the temperature, or by the chiller if compatible.
	Maintenance switch	For stopping individual motors.
	Counter-flanges	In stainless steel, with gaskets, bolts and collar.
	Raised feet	To ensure a good flow of air depending on how the units are installed: against a wall, side by side, etc.
	Blade protective screen	Protection against hail, impacts, etc. For vertical position.
<b>Installation surface constraints</b>	Vertical position	For narrow terraces.
<b>Optimised, secure transport</b>	Stacking of 2 identical devices	
	Skid for transport by container	Secure transport and easy loading/unloading.
<b>Application for water without glycol</b>	Drainable coil	Device located on a slope to prevent frost - drainage by gravity
<b>Free cooling application</b>	Free cooling valve kit	Valves with motor, controlled by the control cabinet. Controlled according to the operation of the dry cooler or chiller.
<b>Adiabatic cooling application</b>	ADIABATIC COOLER (water misting into the air flow)	Size of the unit reduced by cooling of the ambient air. Operates completely safely due to the antibacterial treatment applied to the water (Option).

# DIMENSIONS

## Horizontal Position - Induced Draught

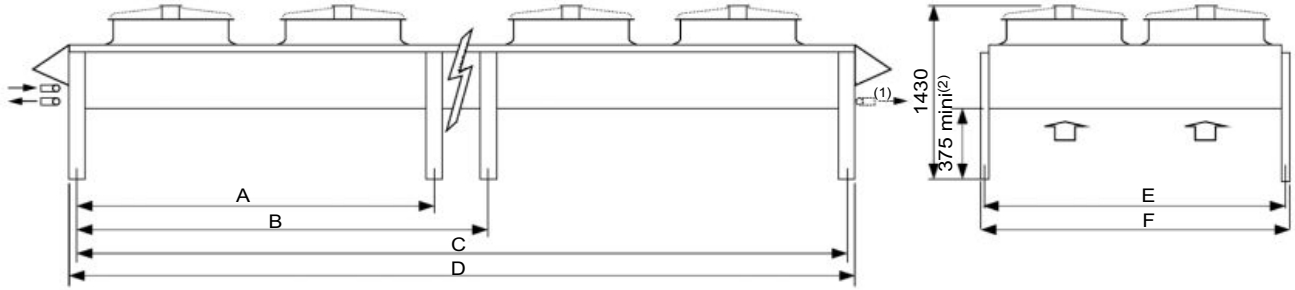

Unit shown has 2 fan lines - no. of motors between the feet is not contractually binding

- (1) for units with input/output piping on the opposite side
- (2) standard feet

	1	2	3	4	5	6	4	6	8	10	12	14
<b>DSN S module</b>												
A	-	-	-	-	1840	1840	-	-	-	1840	1840	1840
B	-	-	-	-	2790	3740	-	-	-	2790	3740	4690
C	830	1780	2730	3680	4630	5580	1780	2730	3680	4630	5580	6530
D	950	1900	2850	3800	4750	5700	1900	2850	3800	4750	5700	6650
H	1388 max											
Max empty weight without options +/-10% (kg)	233	369	503	666	809	928	638	875	1135	1393	1617	1874
<b>DMN M module</b>												
A	-	-	-	3140	3140	-	-	3140	3140	4740	4740	3140
B	-	-	-	4740	4740	-	-	4740	4740	-	-	7940
C	1480	3080	4680	6280	7880	3080	4680	6280	7880	9480	9480	11080
D	1600	3200	4800	6400	8000	3200	4800	6400	8000	9600	9600	11200
H	IMPELLER ø 800: 1388 max - IMPELLER ø 910: 1483 max											
Max empty weight without options +/-10% (kg)	314	523	712	958	1183	918	1298	1645	2029	2388	2388	2772
<b>DLN L module</b>												
A	-	-	-	3740	3740	-	-	3740	3740	5640	5640	-
B	-	-	-	5640	5640	-	-	5640	5640	-	-	-
C	1780	3680	5580	7480	9380	3680	5580	7480	9380	11280	11280	-
D	1900	3800	5700	7600	9500	3800	5700	7600	9500	11400	11400	-
H	IMPELLER ø 800: 1388 max - IMPELLER ø 910: 1483 max											
Max empty weight without options +/-10% (kg)	352	599	846	1110	1373	1036	1474	1929	2384	2806	2806	-
<b>All</b>												
E	1240						2360					
F	1280						2400					

Dimensions in mm, excluding options

## Vertical position

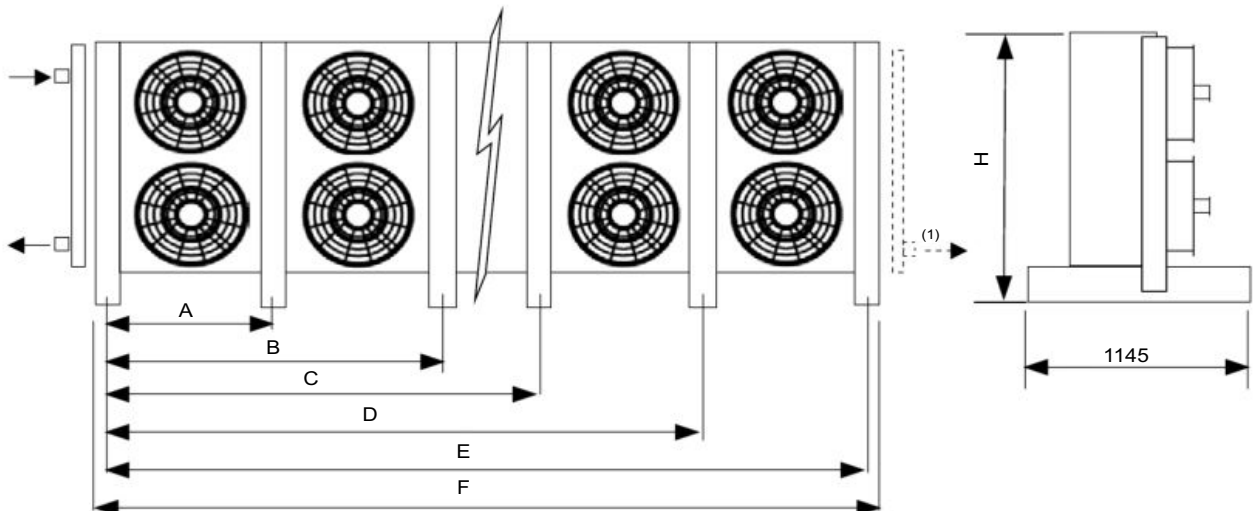

Unit shown has 2 fan lines - no. of motors between the feet is not contractually binding

- (1) For units with input/output piping on the opposite side

## DIMENSIONS

No. of motors		1	2	3	4	5	6	4	6	8	10	12	14
DSN S module	A	-	-	-	1840	1840	1840	-	-	1840	1840	1840	1840
	B	-	-	-	-	2790	3740	-	-	-	2790	3740	4690
	C	-	-	-	-	-	-	-	-	-	-	-	-
	D	-	-	-	-	-	-	-	-	-	-	-	-
	E	830	1780	2730	3680	4630	5580	1780	2730	3680	4630	5580	6530
	F	950	1900	2850	3800	4750	5700	1900	2850	3800	4750	5700	6650
	Max empty weight without options +/-10% (kg)	282	419	554	705	915	1039	684	922	1181	1497	1727	1983
DMN M module	A	-	-	1540	1540	1540	-	1540	1540	1540	3140	3140	3140
	B	-	-	3140	4740	3140	-	3140	4740	3140	6340	4740	4740
	C	-	-	-	-	4740	-	-	-	4740	-	6340	6340
	D	-	-	-	-	6340	-	-	-	6340	-	7940	7940
	E	1480	3080	4680	6280	7880	3080	4680	6280	7880	9480	11080	11080
	F	1600	3200	4800	6400	8000	3200	4800	6400	8000	9600	11200	11200
	Max empty weight without options +/-10% (kg)	356	558	835	1046	1339	927	1383	1734	2187	2464	2920	2920
DLN L module	A	-	-	1840	1840	1840	-	1840	1840	1840	3740	3740	3740
	B	-	-	3740	5640	3740	-	3740	5640	3740	7540	7540	7540
	C	-	-	-	-	5640	-	-	-	5640	-	7540	7540
	D	-	-	-	-	7540	-	-	-	7540	-	9440	9440
	E	1780	3680	5580	7480	9380	3680	5580	7480	9380	11280	11280	11280
	F	1900	3800	5700	7600	9500	3800	5700	7600	9500	11400	11400	11400
	Max empty weight without options +/-10% (kg)	399	639	972	1204	1537	1053	1572	1986	2501	2842	3356	3356
All	H	1370						2490					

Dimensions (mm)

## INSTALLATION RECOMMENDATIONS

■ These units are designed to operate outside. When starting up, frost and snow could adversely affect the operation of horizontal units.

As a general measure, all steps should be taken to avoid the risk of air recycling. This is especially important when the installation comprises several units.

It is not recommended to install units near the hot air extraction duct outlet or close to deciduous plants (this could cause fouling).

■ **A horizontal unit** must have a surrounding clearance of 1.0 m. Where the use of anti-vibration mounts is required, use a rigid frame which locks the feet together.

■ **A vertical unit** should preferably be placed parallel to the direction of the wind. It is not recommended for use with low fan rotation speeds. In addition, we recommend that these units be stabilised using braces connecting their two upper ends to fixed supports (wall or framework).

■ Avoid using **speed regulators** and prioritise EC motor solutions.

■ **Commissioning and maintenance:** refer to the instruction manual.

■ These units **comply with the European directives.** The installer is responsible for ensuring the compliance of the installation. The installer must ensure safety and protective devices (emergency stop, shut-off valves, lightning protection, etc.) are put in place and are accessible.





## DRY COOLERS

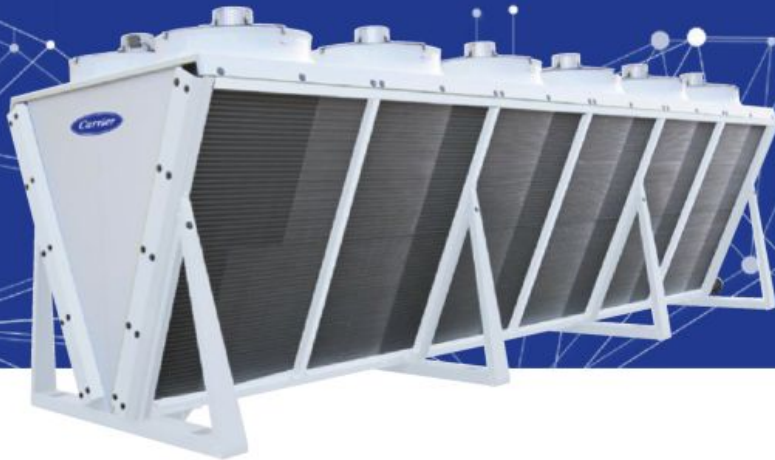

Compact design  
Acoustic comfort  
40% smaller footprint

## 09VE

From 100 to 1870 kW

Dry coolers in this range are mainly designed for cooling water or glycol/water mix for:

- Condensers for water chillers,
- Free cooling.

These devices are designed to be installed outdoors.

## DESCRIPTION

### Excellent resistance to corrosion

The casing offers 480 hours of resistance in salt spray tests in accordance with ISO 9227, C3 corrosion class Long durability in excess of 15 years or C4 Intermediate durability between 5 and 15 years, in line with ISO standard 12944-2.

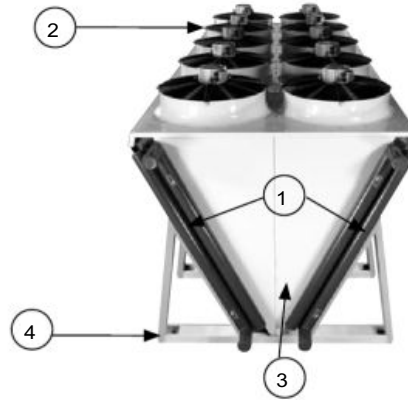

#### ① 2 Non-drainable coils

Copper tubes and high-performance aluminium fins, resistant to fouling.

Manifolds and piping: unpainted copper except for diameter 125 which are RAL 7024 graphite grey painted steel.

#### ② Fan motor assemblies

Profiled collars in galvanised steel with RAL7035 polyester powder paint or RAL7035 composite depending on the motor reference.

Aluminium + polypropylene propeller.

Class F motors - IP54 - TRI400V +/-10% 50Hz+/-2%.

Black protective grille compliant with standard NF ISO 12499.

Partitioning in pairs.

EC motors can be used in 50 or 60 Hz and from 380 to 480V +/- 10%.

#### ③ Casing

Galvanised steel with polyester powder paint in RAL7035 light grey.

#### ④ Feet

Galvanised steel with polyester powder paint in RAL7035 light grey

Each device is tested:

- The coil sealing is subjected to an underwater airtightness test.
- For devices with the terminal strip or electrical cabinet option: rotation tests, dielectric tests, current measurement.

The entire range complies with the following European directives:

- Machinery directive 2006/42/EC,
- EMC directive 2014/30/EU,
- Pressure Equipment Directive (PED) 2014/68 EU.

## RANGE

- A range of sizes, from 6 to 20 fans.
- 2 impeller diameters, 800 or 910 mm.
- Adaptation of the rotation speed (EC motor).

Various combinations of these elements, as well as the choice of a number of options, allow us to provide devices that are adapted to a range of applications and environments.

## DESCRIPTION

09VE 1 16 4 UI 690 E 9A

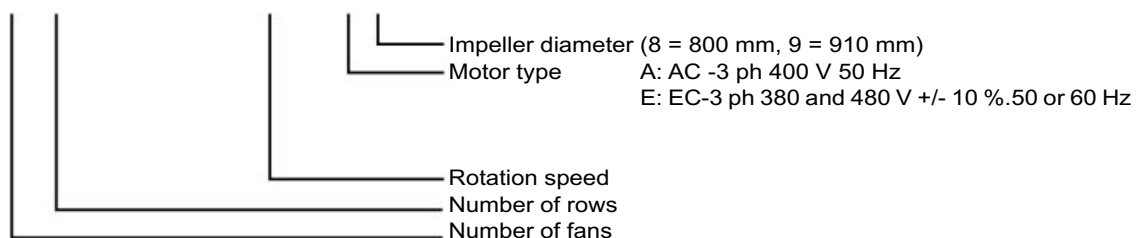







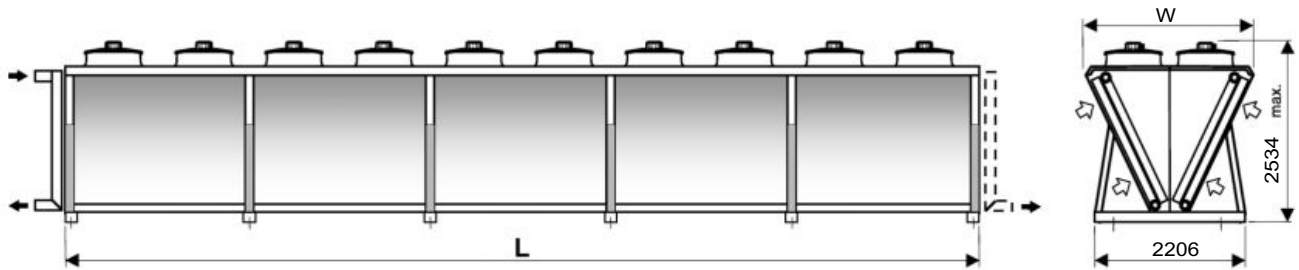

## OPTIONS FOR EACH APPLICATION

	Options	Description/advantages
<b>Protection adapted for the environment</b>	Pre-coated aluminium fins	Improves the resistance of the fins to corrosion. For applications in coastal areas, industrial areas or highly populated areas.
	High-efficiency coating on fins: ALUCOAT®507/HERESITE (on request)	Improves the resistance of the fins to corrosion. For relatively corrosive environments.
	Corrosiveness resistance category C5M	Casing and fan motor assemblies for corrosive environments.
<b>Quick, simple installation</b>	Terminal box	Connection to the terminals of each motor on the front panel of the device.
	Protection cabinet	Protected by a thermal-magnetic circuit breaker on each motor.
	Control cabinet	Motor and control protection, either by electronic board, depending on the temperature, or by the chiller if compatible.
	Flanges	ISO PN16 02A type rotating flanges as per DIN 2642 in 304L stainless steel up to DN100 and steel flange NFEN 1092-1 for DN125
	Maintenance switch	1 switch for 2 fan motor assemblies, option on request
	Counter-flanges	In 304L stainless steel up to DN100 and steel for DN125, with gaskets and bolts.
	Blade protective screen	Impact protection
<b>Application for water without glycol</b>	Drainable coil	Device located on a slope to prevent frost - drainage by gravity
<b>Free cooling application</b>	Free cooling valve kit	Valves with motors controlled by the control cabinet. Controlled according to the operation of the dry cooler or water chiller.
<b>Adiabatic cooling application</b>	ADIABATIC COOLER (water misting into the air flow)	Size of the unit reduced by cooling of the ambient air. Operates completely safely due to the antibacterial treatment applied to the water (Option).
<b>Secure transport</b>	Skid for transport by container	Secure transport and easy loading/unloading. Available for 5-row models up to 18 fan motor assemblies, outside plant consultation.

## DIMENSIONS



	1060	1080	1100	1120	1140	1160	1180	1200
								
L (mm)	3550	4700	5850	7000	8150	9300	10450	11660
w (mm)	2305 to 2420 depending on the model							

Up to size 1180, these units can be transported by container.  
Dimensions without options

## INSTALLATION RECOMMENDATIONS

- These units are designed to operate outside. When starting up, frost and snow could adversely impair its operation.  
 As a general measure, all steps should be taken to avoid the risk of air recycling. This is especially important when the installation comprises several units.  
 It is not recommended to install units near the hot air extraction duct outlet or close to deciduous plants (this could cause clogging).
- Allow a clearance of 1.0 m around the device. Where the use of anti-vibration mounts is required, use a rigid frame which locks the feet together.
- Avoid using **speed regulators** and prioritise EC motor solutions.
- Commissioning and maintenance:** refer to the instruction manual.
- These units **comply with the European directives**. The installer is responsible for ensuring the compliance of the installation. The installer must ensure safety and protective devices (emergency stop, shut-off valves, lightning protection, etc.) are put in place and are accessible.



## GASKETED PLATE HEAT EXCHANGERS

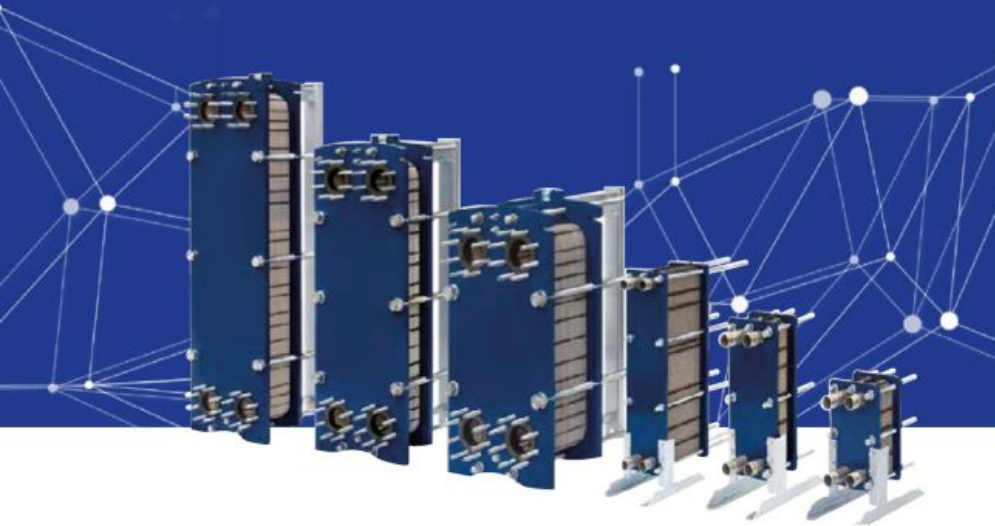

Decoupling of the machines to the system

Cost efficient design

Qualified and reliable

High heat transfer coefficient

Close temperature approach

## 10TE

Large range capable to handle water flow rate up to 800m<sup>3</sup>/h

10TE gasketed plate heat exchangers are particularly well-suited for a wide range of applications:

- Heat pump installations
- Water cooled chillers
- Heat recovery
- Heating and cooling sub-stations
- Domestic water heating
- Swimming pool heating
- Recovery on corrosive waste
- Geothermal energy recovery
- Industrial processes

## DESCRIPTION

Gasketed plate heat exchanger consists of a number of corrugated heat transfer plates (P) compressed by means of tightening bolts (B) between a front fixed frame plate (F) and a rear moveable frame plate (R). Specific rubber gaskets (G) fastened on each plates generates two alternating independent circuits where the heat transfer between the two fluids take place in parallel and countercurrent flow. The unit is connected with the pipe system by nozzles or flanged connections (C).

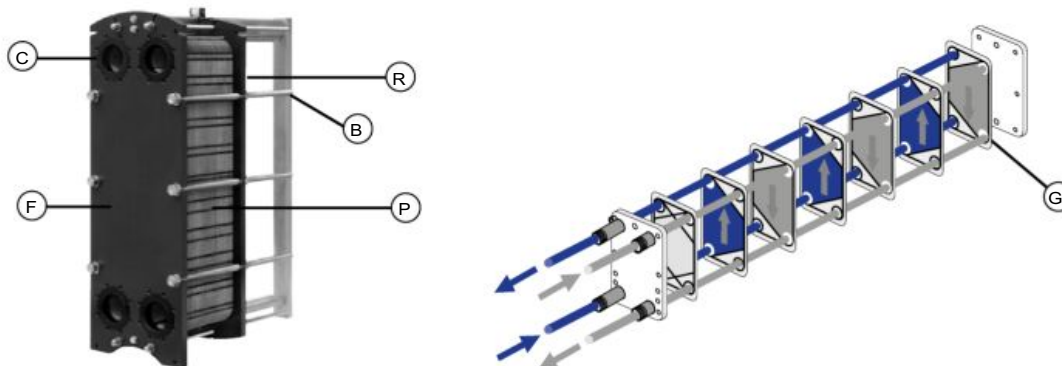

## SELECTION

Due to the range's extreme modularity, the thermal selection must be optimised on the thermal requirements and the allowable pressure drops of each circuit. The importance of pressure drops must not be underestimated when selecting an heat exchanger, as it influences the choice of model and number of plates and thus the heat transfer area.

The heat transfer area is also influenced by other factors, such as the height to width ratio, the angle and depth of the chevron patterns.

## ADVANTAGES

- Excellent heat transfer coefficient
- Very low pinch point temperatures possible
- High corrosion resistance
- Compact footprint
- Easy to install and to maintain
- Low-capacity circuits and fluid retention volume
- Possibility of heat transfer area extension
- Maximum differential pressure equal to maximum operating pressure

## PRECAUTIONS

- Do not damage the exchanger gaskets:
  - Avoid water hammering, overpressure/temperature and limit on/off cycles.
  - Do not use 1/4-turn valves.
  - Use with steam between 0 and 3 bar (effective) (Except for 10TEE455+ & 10TEE705+).
  - Provide a control system adapted to the requirements and which takes the low capacity of the circuits into account.
- Ensure the plates are kept clean so they maintain their thermal efficiency:
  - Filter fluids containing suspended particles.
  - Ensure the fluids are constantly circulating in the exchanger to prevent any build-up or scale.
  - Install nozzles on the pipes for cleaning in place.

**RANGE**

	10TEE020+	10TEE040+	10TEE080+	10TEE070+	10TEE160+	10TEE260+	10TEE110+	10TEE210+	10TEE410+									
Width mm	145			245			320											
Height mm	305	455	740	527	857	1202	584	848	1375									
Connections diameter	DN32 1"1/4			DN50 2"			DN65 2"1/2											
Corrugation angle	H/L			H/L			H/L											
Max. water flowrate m <sup>3</sup> /h	19			63			80											
PS=> Max working pressure bar	10	16	25	10	16	25	10	16	25	10	16	25	10	16	25	10	16	25

	10TEE270+	10TEE300+	10TEE450+	10TEE455+	10TEE705+							
Width mm	320	425		427								
Height mm	1071	877	1322	1325	1770							
Connections diameter	DN80 3"	DN100 4"										
Corrugation angle	H/L	H/L										
Max. water flowrate m <sup>3</sup> /h	110	240										
PS=> Max working pressure bar	10	16	25	10	16	25	10	16	25	10	16	25

	10TEE400+	10TEE600+	10TEE900+	10TEE650+	10TEE990+			
Width mm	500			678	668			
Height mm	1055	1503	1951	1340	1825			
Connections diameter	DN150 6"			DN200 8"				
Corrugation angle	H/L			H/L				
Max. water flowrate m <sup>3</sup> /h	380			800	730			
PS=> Max working pressure bar	10	16	10	16	10	16	10	16

- Plate thickness : 0,4mm - 0,5mm - 0,6mm - 0,7mm (Except for 10TEE455+ & 10TEE705+) - availability according to model, material, pressure
- Plate material : 304 stainless steel - 316L stainless steel - 254 SMO (Except for 10TEE455+ , 10TEE705+ & 10TEE990+) - Titanium (Except for 10TEE455+ & 10TEE705+)
- Gasket material : NBR - EPDM Prx - FPM (Except for 10TEE455+ & 10TEE705+)
- Frame material : Carbon steel - Stainless steel (Except for 10TEE455+ & 10TEE705+)

## OPTIONS

### Double wall plates section

10TEE040+ 10TEE080+ 10TEE160+

#### Description

Double-wall plates consist of two identical heat transfer plates embossed together and then joined by laser welding around the inlet and outlet portholes. Such kind of coupling generates a thin air gap between the two plates that, in case of welding or plate's failure, prevents fluids intermixing and brings to an external leakage visually detectable. Suitable for all the heat transfer processes where cross contamination is to avoid, the double-wall plates are the right solution for all those HVAC applications where a higher level of safety is recommendable and/or required by local rules.

#### Benefits

Minimize the risk of fluids intermixing.

Allow visual detection from the outside of any internal leak.  
Offer all the advantages of Gasketed Plate Heat Exchanger technology: maximum heat transfer, compact design and easy maintenance.

#### Technical data

Material of plates: AISI 316L

Design standard: PED 2014/68/EU up to risk cat. IV Pressure design / test (g): up to 16 / 26 bar

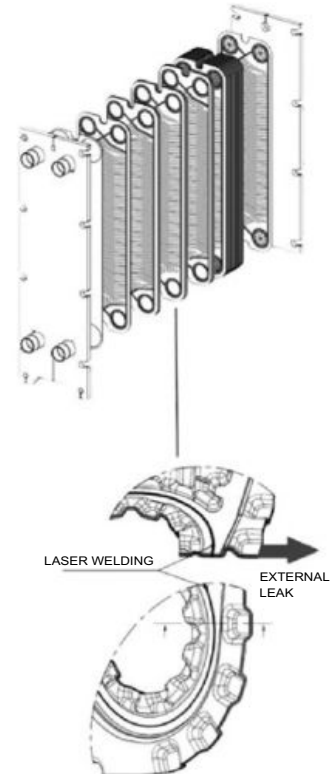

## ACCESSORIES

### FL insulation (DN 32, DN 50 and DN 65 models)

#### Description

FL is the thermal insulation jacket designed to combine thermal insulation performance, compactness and versatility in heating and cooling applications of our plate heat exchangers up to size DN65 (2"1/2).

Made of closed cell expanded elastomer with an external PVC protection layer it's highly flexible and soft-touch.

Supplied as a four pieces kit, it can be easily and quickly assembled thanks to practical hook and loop closure system.

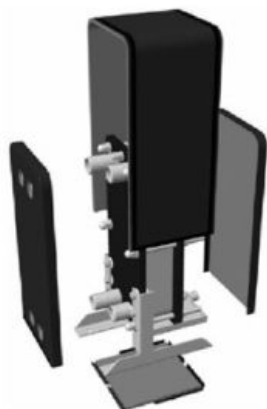

#### Advantages

- Heat exchanger fully contained in the insulation jacket: minimized energy losses and condensation, higher level of safety and comfort for those who work around the heat exchanger.
- Prepackaged insulation, with pre-cut holes and strap fastening: easy and quick installation, reduced installation costs. No special tools required for the assembly.
- Lightweight and highly flexible material: easy to adapt on site to any product's configuration and to fulfill different customer's needs.
- Reduced transport and stockage costs

#### Technical specifications

Exterior finish:

- Blue PVC protection layer 0,6 mm thick.
- Protective against mechanical wear and UV-radiation.

Insulating materials:

- Black closed-cell flexible elastomeric foam (FEF).
- 9 mm thick for 020+, 040+, 080+, and 19 mm thick for 070+, 160+, 260+, 110+, 210+ models.
- Thermal conductivity coefficient ( $\lambda$ -value):  $\leq 0,038 \text{ W/(m}\cdot\text{k)}$  at 40°C (EN12667).
- Fire reaction: B – s3, d0 (EN 13501-1).
- Flexible and expanded CFC and HCFC-free rubber foam. It does not damage the ozone layer (ODP zero) and does not contribute to the greenhouse effect (GWP zero). Do not contain cadmium and Formaldehyde.
- Operating temperature limits: -10°C / + 110°C



ACCESSORIES

Dimensions

DN 32				
10TEE020+	L	H	W	h
Max. 29 p.	280	450	130	125
Max. 49 p.	380	450	130	125
Max. 75 p.	580	450	130	125
10TEE040+	L	H	W	h
Max. 29 p.	280	595	130	125
Max. 49 p.	380	595	130	125
Max. 75 p.	580	595	130	125
10TEE080+	L	H	W	h
Max. 29 p.	280	865	130	125
Max. 49 p.	380	865	130	125
Max. 75 p.	580	865	130	125
Max. 101 p.	580	865	130	125

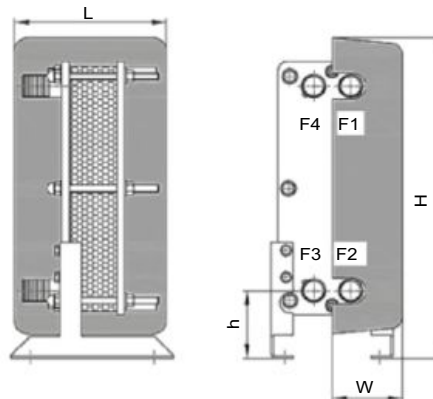

DN 50				
10TEE070+	L	H	W	h
Max. 41 p.	472	858	185	250
Max. 71 p.	612	858	185	250
Max. 101 p.	752	858	185	250
Max. 151 p.	982	858	185	250
10TEE160+	L	H	W	h
Max. 41 p.	472	1188	185	250
Max. 71 p.	612	1188	185	250
Max. 101 p.	752	1188	185	250
Max. 151 p.	982	1188	185	250
Max. 251 p.	1442	1188	185	250
10TEE260+	L	H	W	h
Max. 41 p.	472	1533	185	250
Max. 71 p.	612	1533	185	250
Max. 101 p.	752	1533	185	250
Max. 151 p.	982	1533	185	250
Max. 251 p.	1442	1533	185	250

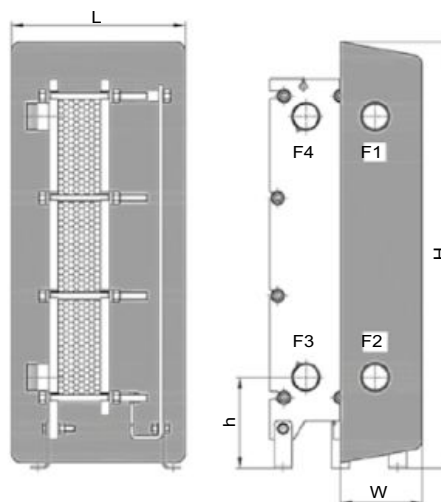

DN 65				
10TEE110+	L	H	W	h
Max. 41 p.	490	900	233	251
Max. 71 p.	630	900	233	251
Max. 101 p.	770	900	233	251
Max. 151 p.	1000	900	233	251
10TEE210+	L	H	W	h
Max. 41 p.	490	1160	233	251
Max. 71 p.	630	1160	233	251
Max. 101 p.	770	1160	233	251
Max. 151 p.	1000	1160	233	251

All dimensions are given in mm. The dimensional tolerance is compatible with the accuracy permitted by the thermoforming process.

## ACCESSORIES

### PB insulation (DN 65, DN 80, DN 100, DN 150 and DN 200 models)

#### Description

PB is the thermal insulation specifically designed for HVAC applications of our larger size plate heat exchangers.

PB is a self-supporting modular structure made with insulating panels (thickness 45 mm) anchored together by means of locking hooks and coupled in such a way as to minimize the thermal bridges.

The particular sandwich structure of the insulating panels, obtained by coupling two Aluminum foils to the polyurethane foam, ensures to the case high thermal insulation, good structural rigidity and appropriate surface finish.

Supplied as a kit, it is easily and quickly assembled without the use of special tools.



#### Advantages

- Heat exchanger completely contained inside the insulation: minimized energy losses and condensation, higher level of safety and comfort for those who work around the heat exchanger.
- Low installation costs.
- Quick and easy access to the heat exchanger for inspection.

#### Technical specifications

- Exterior finish of the panels: smooth sheet of pre-painted Aluminum RAL 2306 (thickness 0,5 mm).
- Insulating material: rigid foam of polyurethane with a high percentage of closed cells (above 95%) and a density of 48 kg/m<sup>3</sup>.
- Initial thermal conductivity coefficient ( $\lambda$ -value) of the insulating material: 0,024 W/m °C (measured at an average temperature of 10°C according to ISO 8302).
- Operating temperature: -10°C / + 130°C.
- Classification of fire resistance of the insulating material: B - 2s, d0 (according to EN 13501-1: 2007).

## ACCESSORIES

### Dimensions

DN 65				
10TEE410+	L	H	W	h
Max. 41 p.	842	1637	554	171
Max. 71 p.	842	1637	554	171
Max. 101 p.	982	1637	554	171
Max. 151 p.	1212	1637	554	171
Max. 251 p.	1701	1637	554	171

DN 80				
10TEE270+	L	H	W	h
Max. 41 p.	842	1357	554	198
Max. 71 p.	842	1357	554	198
Max. 101 p.	982	1357	554	198
Max. 151 p.	1212	1357	554	198
Max. 251 p.	1701	1357	554	198

DN 100				
10TEE300+	L	H	W	h
Max. 101 p.	1074	1180	678	198
Max. 201 p.	1574	1180	678	198
Max. 301 p.	2074	1180	678	198
Max. 401 p.	2574	1180	678	198

10TEE450+ & 10TEE455+				
L	H	W	h	
Max. 101 p.	1074	1625	678	198
Max. 201 p.	1574	1625	678	198
Max. 301 p.	2074	1625	678	198
Max. 401 p.	2574	1625	678	198

10TEE705+				
L	H	W	h	
Max. 101 p.	1074	2090	678	198
Max. 201 p.	1574	2090	678	198
Max. 301 p.	2074	2090	678	198
Max. 401 p.	2574	2090	678	198

DN 150				
10TEE400+	L	H	W	h
Max. 101 p.	1074	1433	757	256
Max. 201 p.	1574	1433	757	256
Max. 301 p.	2074	1433	757	256
Max. 401 p.	2574	1433	757	256
Max. 551 p.	3374	1433	757	256

10TEE600+				
L	H	W	h	
Max. 101 p.	1074	1881	757	256
Max. 201 p.	1574	1881	757	256
Max. 301 p.	2074	1881	757	256
Max. 401 p.	2574	1881	757	256
Max. 551 p.	3374	1881	757	256

10TEE900+				
L	H	W	h	
Max. 101 p.	1074	2374	757	256
Max. 201 p.	1574	2374	757	256
Max. 301 p.	2074	2374	757	256
Max. 401 p.	2574	2374	757	256
Max. 551 p.	3374	2374	757	256
Max. 701 p.	4204	2374	757	256

DN 200				
10TEE650+	L	H	W	h
Max. 151 p.	1504	1764	957	285
Max. 251 p.	2104	1764	957	285
Max. 351 p.	2504	1764	957	285
Max. 551 p.	3404	1764	957	285

10TEE990+				
L	H	W	h	
Max. 151 p.	1504	2263	957	285
Max. 251 p.	2104	2263	957	285
Max. 351 p.	2504	2263	957	285
Max. 551 p.	3404	2263	957	285

All dimensions are given in mm. The dimensional tolerance is compatible with the accuracy permitted by the thermoforming process. The dimensions shown do not include the dimensions of the locking hooks. Total size: W + 30 mm / 30 mm L + / H + 15 mm.

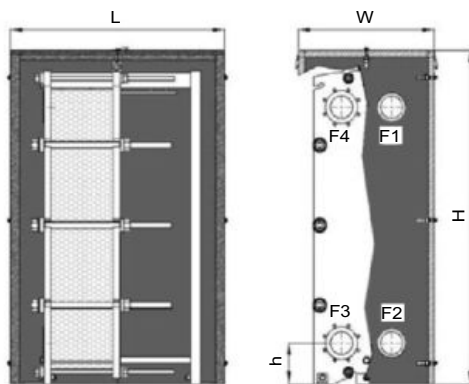

## ACCESSORIES

### Drip tray (all models)

#### Description

The drip tray is a safeguard device specifically designed to collect water or other fluids in case of unexpected fluid leakage or when the heat exchanger is open for maintenance.

Strongly recommended in case of hazardous media and when further protection for the outside environment is required, it is also used in cooling applications to collect condensate formed on the outside of the heat exchanger.

Designed to be positioned under the heat exchanger and fixed by fastening bolts on the anchor brackets, the drip tray is dimensioned to hold the entire plate pack and the two frame plates. In this way all eventual fluids coming from the heat exchanger can be collected in the drip tray and drained by mean of the apposite draining pipe.

#### Advantages

- Reduced risk of flooding in case of condensate, unexpected fluid leakage or when the heat exchangers is open for maintenance.
- Possibility to adjust tilt to facilitate drainage.
- Low installation costs.

#### Technical specifications

Material of construction: Stainless steel AISI 304 (thickness 1mm).

Draining pipe: 3/4" sleeve internally threaded

#### Main dimensions

The drip trays are available in various sizes to be fitted to all models of the standard range of gasketed plate heat exchangers.

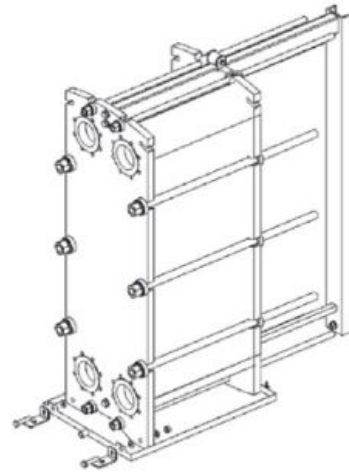

## ACCESSORIES

### Plate pack protection

#### All models

##### Description

The Plate Pack Protection is a safeguard device specifically designed to protect personnel in case of unexpected leakage. Strongly recommended in case of hazardous services, it should be always used when temperatures are over 60°C also when handling uncritical media.

The Plate Pack Protection consists of two or more metal sheets shaped to cover the plate pack and to fit the plate heat exchangers. On smaller units the sheets cover the plate pack enveloping the frame plates. On larger units the sheets are fitted between the tightening bolts and the plate pack.

Supplied as a kit, it is easily and quickly assembled without the use of tools nor screws or bolts.

##### Benefits

Higher level of safety for those who work around the heat exchanger.

Protection of the plate pack in case of aggressive or polluted environment.

Quick and easy access to the heat exchanger for inspection.  
Low installation costs.

##### Technical data

Material of construction: Stainless steel AISI 304 (thickness 1 mm).

##### Main dimensions

Each Plate Pack Protection is factory-tailor-made to fit to the specific plate heat exchanger.

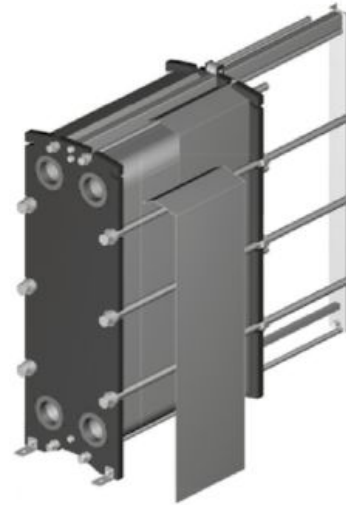







# Heating

# 501

Type	Range	Refrigerant	Cooling capacity, kW	Heating capacity, kW	Page
<b>Air-to-water heat pumps, axial fan</b>					
With scroll or rotary compressors					
	30RQ 017-021	R-410A	16-20	17-22	503
	30RQ 026-040	R-410A	26-39	29-41	513
	61AF 030-105	R-407C	-	26-102	521
NEW	61CG	R-134a	-	30-130	533
	30RQ 040R-160R	R-32	40-160	40-160	539
	30RQ-/30RQP 165-1040R	R-32	160-1000	180-1075	563
<b>Water-to-water heat pumps</b>					
with scroll compressors					
	61WG	R-410A	-	29-230	613
	30WG	R-410A	25-190	29-230	633
	30WI	R-410A	200-700	230-800	667
with screw compressors					
	30XWHPZE	R-1234ze	271-1110	322-1297	677
	30XWHVZE	R-1234ze	448-1312	523-1555	691
	30XWHV	R-134a	587-1741	648-1932	703
	30XWH / 30XWHP	R-134a	269-1736	317-2019	715
NEW	61CA	R-1234yf	-	410	743
NEW	61CWD	R-1233zd	-	110-540	751
NEW	61CW-Z	R-1234ze	-	410-735	761
	61XWH-ZE	R-1234ze	-	300-1570	769



## AIR-TO-WATER HEAT PUMPS



Easy and fast installation  
Hydraulic module available  
Economical operation  
Superior reliability

## 30RQ 017-021 A



Nominal heating capacity 30RQ: 17-22 kW  
Nominal cooling capacity 30RQ: 16-20 kW

The Aquasnap liquid chiller/heat pump range was designed for commercial applications such as the air conditioning of offices and hotels etc.

The new Aquasnap units integrate the latest technological innovations:

- Ozone-friendly refrigerant R410A
- Scroll compressors
- Low-noise fans
- Auto-adaptive microprocessor control

The Aquasnap units are equipped with a hydraulic module integrated into the unit chassis, limiting the installation to straightforward operations like connection of the power supply and the water supply and return piping.



## FEATURES

### Quiet operation

- Compressors
  - Low-noise scroll compressors with low vibration levels
  - The compressor assembly is supported by anti-vibration mountings
- Air heat exchanger section
  - Vertical air heat exchanger coils
  - The latest-generation low-noise fans are now even quieter and do not generate intrusive low-frequency noise
  - Rigid fan installation for reduced start-up noise.

### Access panels, 30RB 017-021



### Easy and fast installation

- Integrated hydraulic module
  - Fixed speed circulator
  - Water filter protecting the water pump against circulating debris
  - High-capacity membrane expansion tank ensures pressurisation of the water circuit
  - Overpressure valve, set to 4 bar
  - Automatic purge valve positioned at the highest point of the hydraulic module to remove air from the system.
  - Thermal insulation and frost protection down to -10°C, using an electric resistance heater and pump cycling.
  - Integrated water fill system to ensure correct water pressure (option)
- Physical features
  - With its small footprint the unit blends in with any architectural styles.
  - The unit is enclosed by easily removable panels, covering all components (except air heat exchanger and fans).
- Simplified electrical connections
  - A single power supply point (power supply without neutral available as an option)
  - Main disconnect switch with high trip capacity
  - Transformer for safe 24 V control circuit supply included
- Fast commissioning
  - Systematic factory operation test before shipment
  - Quick-test function for step-by-step verification of the instruments, electrical components and motors.

## FEATURES

### Economical operation

- Increased energy efficiency at part load
  - In accordance with standard EN 14825/2022 in average climate, the Seasonal Coefficient of performance (SCOP) reaches 3.01 for an energy label of A.
  - Specific Free Defrost algorithm is present to optimise performance and comfort even during defrost period.
- Reduced maintenance costs
  - Maintenance-free scroll compressors
  - Fast diagnosis of possible incidents and their history via the Pro-Dialog+ control
  - R410A refrigerant is easier to use than other refrigerant blends

### Environmental care

- Ozone-friendly R410A refrigerant
  - Chlorine-free refrigerant of the HFC group with zero ozone depletion potential
  - Very efficient - gives an increased energy efficiency ratio (EER)
- Leak-tight refrigerant circuit
  - Brazed refrigerant connections for increased leak-tightness
  - Verification of pressure transducers and temperature sensors without transferring refrigerant charge

### Superior reliability

- State-of-the-art concept
  - Cooperation with specialist laboratories and use of limit simulation tools (finite element calculations) for the design of the critical components, e.g. motor supports, suction/discharge piping etc.
- Auto-adaptive control
  - Control algorithm prevents excessive compressor cycling and permits reduction of the water quantity in the hydraulic circuit (Carrier patent)
- Exceptional endurance tests
  - Corrosion resistance tests in salt mist in the laboratory
  - Accelerated ageing test on components that are submitted to continuous operation: compressor piping, fan supports
  - Transport simulation test in the laboratory on a vibrating table.

### Pro-Dialog+ control

Pro-Dialog+ combines intelligence with operating simplicity. The control constantly monitors all machine parameters and precisely manages the operation of compressors, expansion devices, fans and of the water heat exchanger water pump for optimum energy efficiency.

#### Pro-Dialog+ interface

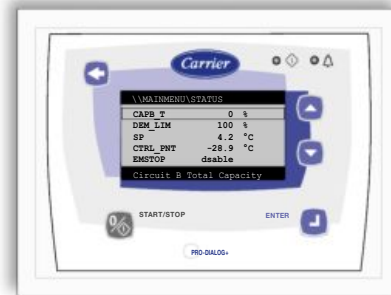

- Energy management
  - Seven-day internal time schedule clock: Permits unit on/off control and operation at a second set point
  - Set point reset based on the outside air temperature or the return water temperature or on the water heat exchanger delta T
  - Master/slave control of two units operating in parallel with operating time equalisation and automatic change-over in case of a unit fault.
  - Change-over based on the outside air temperature
- Integrated features
  - Night mode: Capacity and fan speed limitation for reduced noise level
- Ease-of-use
  - The new backlit LCD interface includes a manual control potentiometer to ensure legibility under any lighting conditions.
  - The information is displayed clearly in English, French, German, Italian and Spanish (for other languages please consult Carrier)
  - The Pro-Dialog+ navigation uses intuitive tree-structure menus, similar to the Internet navigators. They are user-friendly and permit quick access to the principal operating parameters: number of compressors operating, suction/discharge pressure, compressor operating hours, set point, air temperature, entering/leaving water temperature.



## FEATURES

### Remote operating mode with volt-free contacts (standard)

A simple two-wire communication bus between the RS485 port of the Aquasnap and the Carrier Comfort Network offers multiple remote control, monitoring and diagnostic possibilities. Carrier offers a vast choice of control products, specially designed to control, manage and supervise the operation of an air conditioning system. Please consult your Carrier representative for more information on these products.

- Start/stop: Opening of this contact will shut down the unit
- Dual set point: Closing of this contact activates a second set point (example: Unoccupied mode)
- Alert indication: This volt-free contact indicates the presence of a minor fault
- Alarm indication: This volt-free contact indicates the presence of a major fault that has led to the shut-down of the unit
- User safety: This contact can be used for any customer safety loop, closing of the contact generates a specific alarm
- Out of service: This signal indicates that the unit is completely out of service
- Unit capacity: This analogue output (0-10 V) gives an immediate indication of the unit capacity
- Compressor operation: This contact signals that the compressor is in operation

### Remote interface (option)

This interface allows access to the same menus as the unit interface and can be installed up to 300 m away. It includes a box that can be mounted inside the building. The power supply is provided via a 220 V/24V transformer supplied.

## TYPE KEY

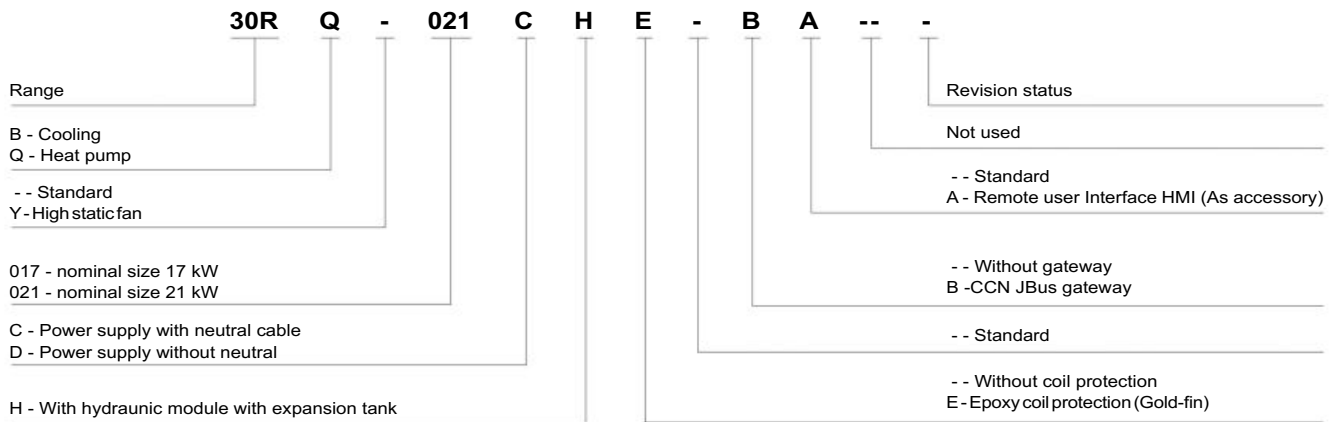

## PHYSICAL DATA, 30RB UNITS

30RB Cooling Only			017	021	
<b>Cooling</b>					
<b>Full Load</b>	CA1	Nominal capacity	kW	16,5	21,5
		EER	kW/kW	3,08	3,16
	CA2	Nominal capacity	kW	22,8	29,8
		EER	kW/kW	3,88	3,92
<b>Seasonal Efficiencies</b>	<b>SEPR <sub>-2/-8°C</sub> Process medium temp.*** kWh/kWh</b>			<b>2,99</b>	<b>3,03</b>
	SEPR <sub>12/7°C</sub> Process high temp.		kWh/kWh	5,46	5,42
	SEER <sub>12/7°C</sub> Comfort low temp.		kWh/kWh	3,53	3,53
	SEER <sub>23/18°C</sub> Comfort medium temp.		kWh/kWh	4,22	4,08
<b>Operating weight<sup>(1)</sup></b>					
Standard unit, with hydraulic module		kg	189	208	
Standard unit, without hydraulic module		kg	173	93	
<b>Sound power level<sup>(2)</sup></b>		dB(A)	72	74	
Sound pressure level at 10 m <sup>(3)</sup>		dB(A)	40	42	
<b>Dimensions</b>					
Length		mm	1136		
Depth		mm	584		
Height		mm	1579		
<b>Compressor</b>		One hermetic scroll compressor			
<b>Refrigerant charge R-410A</b>		kg	5,5	6,4	
		teqCO <sub>2</sub>	11,5	13,4	
<b>Control</b>		Pro-Dialog+			
<b>Fans</b>		Two twin-speed axial fans, 3 blades			
Diameter		mm	495	495	
Air flow		l/s	2212	2212	
Speed		r/s	14,5	14,5	
<b>Water heat exchanger</b>		Plate heat exchanger, maximum operating pressure 1000 kPa			
Water volume		l	1,52	1,9	

- \* In accordance with standard EN14511-3:2022  
 \*\* In accordance with standard EN14825:2022, average climate  
 \*\*\* With EG 30%
- CA1 Cooling mode conditions: Evaporator water entering/leaving temperature 12°C/7°C, outside air temperature 35°C, evaporator frosting factor 0 m<sup>2</sup>.K/W
- CA2 Cooling mode conditions: Evaporator water entering/leaving temperature 23°C/18°C, outside air temperature 35°C, evaporator frosting factor 0 m<sup>2</sup>.K/W
- SEPR <sub>-2/-8°C</sub>**  
**SEER <sub>12/7°C</sub> & SEPR <sub>12/7°C</sub>**  
**SEER <sub>23/18°C</sub>**  
**IPLV.SI**
- Bold values compliant to Ecodesign regulation: (EU) No 2015/1095 for Process application**  
 Values calculated in accordance with EN14825:2022  
 Values calculated in accordance with EN14825:2022
- Calculations according to standard performances AHRI 551-591 (SI)  
 Weight shown is a guideline only. Please refer to the unit nameplate
- (1) In dB ref=10<sup>-12</sup> W, (A) weighting. Declared dualnumber noise emission values in accordance with ISO 4871 (with an associated uncertainty of +/-3dB(A)). Measured in accordance with ISO 9614-1 and certified by Eurovent.
- (2) In dB ref 20µPa, (A) weighting. Declared dualnumber noise emission values in accordance with ISO 4871 (with an associated uncertainty of +/-3dB(A)). For information, calculated from the sound power level Lw(A).
- (3) In dB ref 20µPa, (A) weighting. Declared dualnumber noise emission values in accordance with ISO 4871 (with an associated uncertainty of +/-3dB(A)). For information, calculated from the sound power level Lw(A).



## PHYSICAL DATA, 30RB UNITS

30RB Cooling Only		017	021
<b>Air heat exchanger</b>		Copper tubes and aluminum fins	
Pipe diameter	in	3/8	3/8
Number of rows		2	2
Number of pipes per row		60	60
Fin spacing	mm	1,69	1,69
<b>Standard unit</b>			
Water connections (MPT gas)	in	1	1
<b>Unit with hydraulic module</b>		Pump, screen filter, expansion tank, flow switch, pressure gauge, automatic air purge valve, relief valve	
Pump		One single-speed pump, maximum water-side operating pressure 400 kPa	
Expansion tank capacity	l	5	5
Entering water connection	in	1-1/4	1-1/4
Leaving water connection	in	1	1
Nominal operating current	A	1,3	1,4
<b>Chassis paint colour</b>		Beige	



## PHYSICAL DATA, 30RQ UNITS

30RQ 017-040 Reversible			017	021	
<b>Heating</b>					
<b>Full Load</b>	HA1	Nominal capacity	kW	17,5	21,7
		COP	kW/kW	4,06	4,00
	HA2	Nominal capacity	kW	16,9	21,3
		COP	kW/kW	3,23	3,30
	HA3	Nominal capacity	kW	16,3	20,6
		COP	kW/kW	2,59	2,62
<b>Seasonal Efficiencies</b>		<b>SCOP</b> <sub>30/35°C</sub>	<b>kWh/kWh</b>	<b>3,33</b>	<b>3,32</b>
	HA1	<b>η<sub>s</sub> heat</b>	<b>%</b>	<b>130</b>	<b>130</b>
		P <sub>rated</sub>	kW	13	13
		Energy labelling		A++	A++
<b>Cooling</b>					
<b>Full Load</b>	CA1	Nominal capacity	kW	15,9	20,0
		EER	kW/kW	3,14	3,08
	CA2	Nominal capacity	kW	22,0	27,1
		EER	kW/kW	4,01	3,75
<b>Seasonal Efficiencies</b>		SEPR <sub>12/7°C</sub> Process high temp.	kWh/kWh	5,58	5,34
		SEER <sub>12/7°C</sub> Comfort low temp.	kWh/kWh	3,59	3,44
		SEER <sub>23/18°C</sub> Comfort medium temp.	kWh/kWh	4,33	3,96
<b>Operating weight<sup>(1)</sup></b>					
Standard unit, with hydraulic module			kg	206	223
Standard unit, without hydraulic module			kg	191	208
<b>Sound power level<sup>(2)</sup></b>			dB(A)	72	74
Sound pressure level at 10 m <sup>(3)</sup>			dB(A)	40	42
<b>Dimensions</b>					
Length			mm	1136	
Depth			mm	584	
Height			mm	1579	
<b>Compressor</b>			One hermetic scroll compressor		
<b>Refrigerant charge R-410A</b>			kg	6,4	7,7
			teqCO <sub>2</sub>	13,4	16,1
<b>Control</b>			Pro-Dialog+		

- \* In accordance with standard EN14511-3:2022
- \*\* In accordance with standard EN14825:2022, average climate
- HA1 Heating mode conditions: Water heat exchanger water entering/leaving temperature 30°C/35°C, outside air temperature tdb/twb = 7°C db/6°C wb, evaporator frosting factor 0 m<sup>2</sup>.K/W
- HA2 Heating mode conditions: Water heat exchanger water entering/leaving temperature 40°C/45°C, outside air temperature tdb/twb = 7°C db/6°C wb, evaporator frosting factor 0 m<sup>2</sup>.K/W
- CA1 Cooling mode conditions: evaporator water entering/leaving temperature 12°C/7°C, outside air temperature 35°C, evaporator frosting factor 0 m<sup>2</sup>.K/W
- CA2 Cooling mode conditions: evaporator water entering/leaving temperature 23°C/18°C, outside air temperature 35°C, evaporator frosting factor 0 m<sup>2</sup>.K/W
- η<sub>s</sub> heat<sub>30/35°C</sub> & SCOP<sub>30/35°C</sub>** **SEER<sub>12/7°C</sub> & SEPR<sub>12/7°C</sub>** **SEER<sub>23/18°C</sub>** **IPLV.SI**
- Bold values compliant to Ecodesign regulation: (EU) No 813/2013 for Heat Pump application**
- Values calculated in accordance with EN14825:2022
- Calculations according to standard performances AHRI 551-591 (SI)
- (1) Weight shown is a guideline only. Please refer to the unit nameplate
- (2) In dB ref=10<sup>-12</sup> W, (A) weighting. Declared dualnumber noise emission values in accordance with ISO 4871 (with an associated uncertainty of +/-3dB(A)). Measured in accordance with ISO 9614-1 and certified by Eurovent.
- (3) In dB ref 20μPa, (A) weighting. Declared dualnumber noise emission values in accordance with ISO 4871 (with an associated uncertainty of +/-3dB(A)). For information, calculated from the sound power level Lw(A).



## PHYSICAL DATA, 30RQ UNITS

30RQ 017-040 Reversible		017	021
<b>Fans</b>		Two twin-speed axial fans, 3 blades	
Diameter	mm	495	495
Air flow	l/s	2217	1978
Speed	r/s	14,5	14,5
<b>Water heat exchanger</b>		Plate heat exchanger, maximum operating pressure 1000 kPa	
<b>Water volume</b>	l	1,52	1,9
<b>Air heat exchanger</b>		Copper tubes and aluminum fins	
Pipe diameter	in	3/8	3/8
Number of rows		2,5	3
Number of pipes per row		60	60
Fin spacing	mm	1,69	1,69
<b>Standard unit</b>			
Water connections (MPT gas)	in	1	1
<b>Unit with hydraulic module</b>		Pump, screen filter, expansion tank, flow switch, pressure gauge, automatic air purge valve, relief valve	
Pump		One single-speed pump, maximum water-side operating pressure 400 kPa	
Expansion tank capacity	l	5	5
Entering water connection	in	1-1/4	1-1/4
Leaving water connection	in	1	1
Nominal operating current	A	1,3	1,4
<b>Chassis paint colour</b>		Beige	

## ELECTRICAL DATA, 30RB/RQ UNITS

30RB/RQ		017	021
<b>Power circuit</b>			
Nominal power supply	V-ph-Hz	400-3+N-50 (power supply option C) or 400-3-50 (power supply option D)	
Voltage range	V	340-460	
<b>Control circuit supply</b>			
24 V via internal transformer			
<b>Maximum start-up current (Un)<sup>(1)</sup></b>	A	75	95
<b>Unit power factor at nominal capacity<sup>(2)</sup></b>		0,84	0,79
<b>Maximum operating power input<sup>(2)</sup></b>	kW	7,8	9,1
<b>Nominal current drawn<sup>(3)</sup></b>	A	8	12
<b>Maximum operating current draw (Un)<sup>(4)</sup></b>	A	13	16
<b>Maximum operating current draw (Un-15%)<sup>(5)</sup></b>	A	15	18

(1) Maximum instantaneous start-up current (locked rotor current of the compressor).

(2) Power input, compressors and fans, at the unit operating limits (saturated suction temperature 10°C, saturated condensing temperature 65°C) and nominal voltage of 400 V (data given on the unit nameplate).

(3) Standardised Eurovent conditions: Water heat exchanger entering/leaving water temperature 12°C/7°C, outside air temperature 35°C.

(4) Maximum unit operating current at maximum unit power input and 400 V (values given on the unit nameplate).

(5) Maximum unit operating current at maximum unit power input and 340-460V.

**DIMENSIONS/CLEARANCES**

**30RB/RQ 017-021**

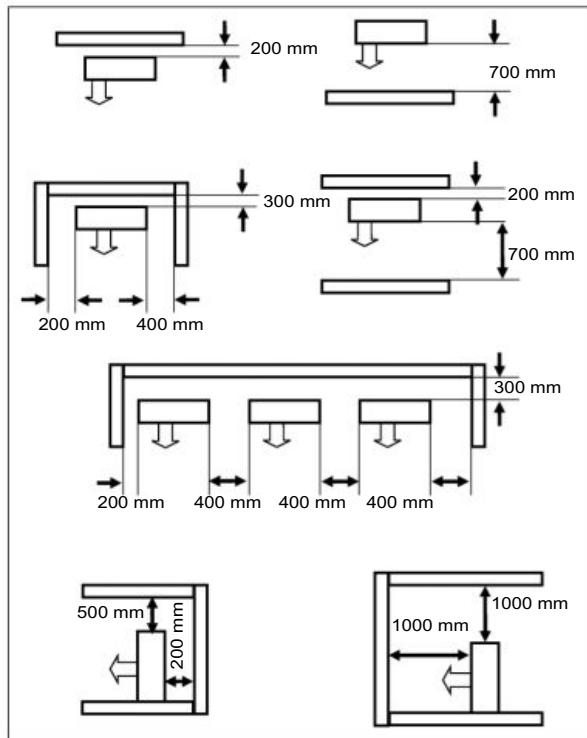
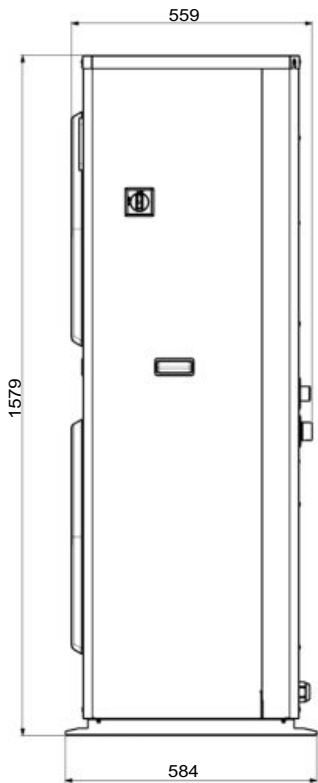
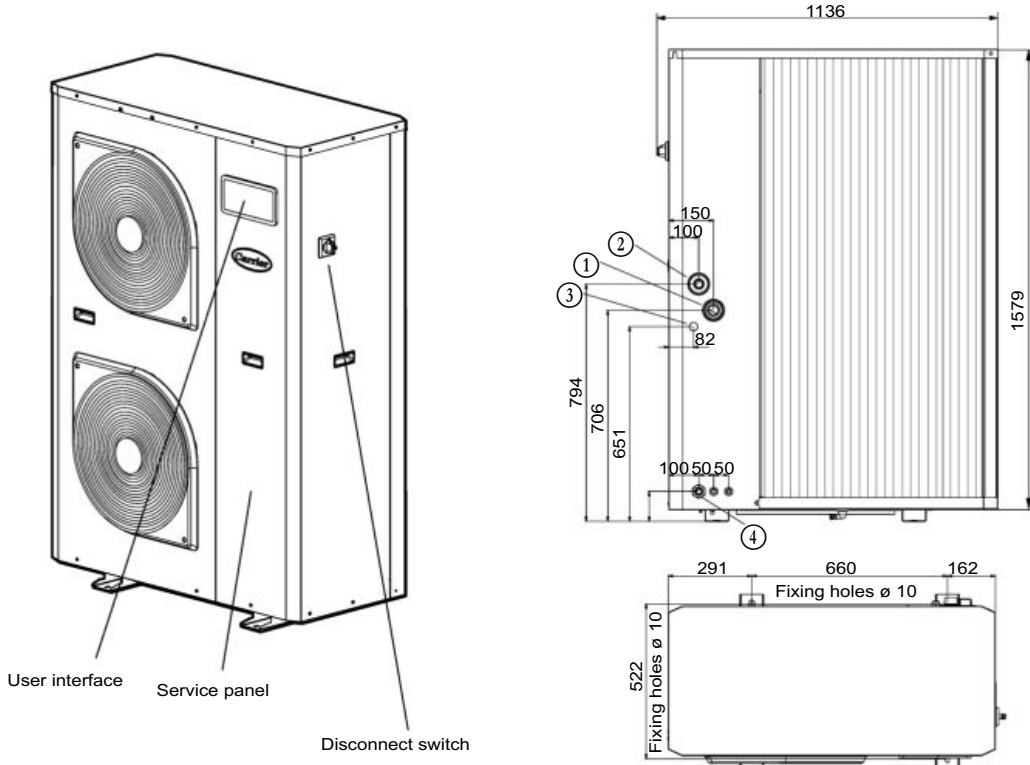

**Legend**

All dimensions are in mm

- ① Water inlet
- ② Water outlet
- ③ Water fill kit connection (option)
- ④ Power connections

## AIR-TO-WATER HEAT PUMPS



- Easy and fast installation
- Hydraulic module available
- Economical operation
- Superior reliability

## 30RQ 026-040 A



Nominal heating capacity 30RQ: 29 - 41 kW  
Nominal cooling capacity 30RQ: 26 - 39 kW

The Aquasnap liquid chiller/heat pump range was designed for commercial applications such as the air conditioning of offices and hotels etc.

The new Aquasnap units integrate the latest technological innovations:

- Non-ozone depleting refrigerant R-410A
- Scroll compressors
- Low-noise fans
- Auto-adaptive microprocessor control

The Aquasnap units are equipped with a hydraulic module integrated into the unit chassis, limiting the installation to straightforward operations like connection of the power supply and the water supply and return piping.



CARRIER participates in the ECP programme for LCP-HP  
Check ongoing validity of certificate:  
[www.eurovent-certification.com](http://www.eurovent-certification.com)



## FEATURES

### Quiet operation

- Compressors
  - Low-noise scroll compressors with low vibration levels
  - The compressor assembly is supported by anti-vibration mountings
- Air heat exchanger section
  - Vertical air heat exchanger coils
  - The latest-generation low-noise fans are now even quieter and do not generate intrusive low-frequency noise
  - Rigid fan installation for reduced start-up noise.

### Easy and fast installation

- Integrated hydraulic module
  - Fixed speed circulator
  - Water filter protecting the water pump against circulating debris
  - High-capacity membrane expansion tank ensures pressurisation of the water circuit
  - Overpressure valve, set to 4 bar
  - Automatic purge valve positioned at the highest point of the hydraulic module to remove air from the system.
  - Thermal insulation and frost protection down to -10°C, using an electric resistance heater and pump cycling.
  - Integrated water fill system to ensure correct water pressure (option)
- Physical features
  - With its small footprint the unit blends in with any architectural styles.
  - The unit is enclosed by easily removable panels, covering all components (except air heat exchanger and fans).
- Simplified electrical connections
  - A single power supply point (power supply without neutral available as an option and in standard for units size 40kW)
  - Main disconnect switch with high trip capacity
  - Transformer for safe 24 V control circuit supply included
- Fast commissioning
  - Systematic factory operation test before shipment
  - Quick-test function for step-by-step verification of the instruments, electrical components and motors.

### Economical operation

- Increased energy efficiency at part load
  - In accordance with standard EN 14825/2022 in average climate, the Seasonal Coefficient of performance (SCOP) reaches 3,27 for an energy label of A.
  - Specific Free Defrost algorithm is present to optimise performance and comfort even during defrost period.
- Reduced maintenance costs
  - Maintenance-free scroll compressors
  - Fast diagnosis of possible incidents and their history via the Pro-Dialog+ control
  - R-410A refrigerant is easier to use than other refrigerant blends

### Environmental care

- Ozone-friendly R-410A refrigerant
  - Chlorine-free refrigerant of the HFC group with zero ozone depletion potential
  - Very efficient - gives an increased energy efficiency ratio (EER/SEER/COP/SCOP)
- Leak-tight refrigerant circuit
  - Brazed refrigerant connections for increased leak-tightness
  - Verification of pressure transducers and temperature sensors without transferring refrigerant charge

#### Hydraulic module



### Superior reliability

- State-of-the-art concept
  - Cooperation with specialist laboratories and use of limit simulation tools (finite element calculations) for the design of the critical components, e.g. motor supports, suction/discharge piping etc.
- Auto-adaptive control
  - Control algorithm prevents excessive compressor cycling and permits reduction of the water quantity in the hydraulic circuit (Carrier patent).
- Exceptional endurance tests
  - Corrosion resistance tests in salt mist in the laboratory
  - Accelerated ageing test on components that are submitted to continuous operation: compressor piping, fan supports
  - Transport simulation test in the laboratory on a vibrating table.

## FEATURES

### Pro-Dialog+ control

Pro-Dialog+ combines intelligence with operating simplicity. The control constantly monitors all machine parameters and precisely manages the operation of compressors, expansion devices, fans and of the water heat exchanger water pump for optimum energy efficiency.

#### Pro-Dialog+ interface

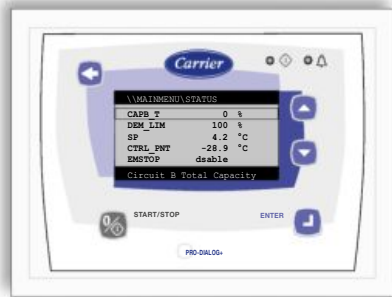

- Energy management
  - Seven-day internal time schedule clock: Permits unit on/off control and operation at a second set point
  - Set point reset based on the outside air temperature or the return water temperature or on the water heat exchanger delta T
  - Master/slave control of two units operating in parallel with operating time equalisation and automatic change-over in case of a unit fault.
  - Change-over based on the outside air temperature
- Integrated features
  - Night mode: Capacity and fan speed limitation for reduced noise level
- Ease-of-use
  - The new backlit LCD interface includes a manual control potentiometer to ensure legibility under any lighting conditions.
  - The information is displayed clearly in English, French, German, Italian and Spanish (for other languages please consult Carrier)
  - The Pro-Dialog+ navigation uses intuitive tree-structure menus, similar to the Internet navigators. They are user-friendly and permit quick access to the principal operating parameters: number of compressors operating, suction/discharge pressure, compressor operating hours, set point, air temperature, entering/leaving water temperature.

### Remote operating mode with volt-free contacts (standard)

A simple two-wire communication bus between the RS485 port of the Aquasnap and the Carrier Comfort Network offers multiple remote control, monitoring and diagnostic possibilities. Carrier offers a vast choice of control products, specially designed to control, manage and supervise the operation of an air conditioning system. Please consult your Carrier representative for more information on these products.

- Start/stop: Opening of this contact will shut down the unit
- Dual set point: Closing of this contact activates a second set point (example: Unoccupied mode)
- Alert indication: This volt-free contact indicates the presence of a minor fault
- Alarm indication: This volt-free contact indicates the presence of a major fault that has led to the shut-down of the unit
- User safety: This contact can be used for any customer safety loop, closing of the contact generates a specific alarm
- Out of service: This signal indicates that the unit is completely out of service
- Unit capacity: This analogue output (0-10 V) gives an immediate indication of the unit capacity
- Compressor operation: This contact signals that the compressor is in operation

### Remote interface (option)

This interface allows access to the same menus as the unit interface and can be installed up to 300 m away. It includes a box that can be mounted inside the building. The power supply is provided via a 220 V/24V transformer supplied.

#### Interface access



PERFORMANCES DATA, 30RB / 30RQ UNITS

			30RB 26	30RB 33	30RB 40	30RQ 26	30RQ 33	30RQ 40	
<b>Heating</b>									
<b>Standard unit</b> Full load performances*	HA1	Nominal capacity	kW	-	-	-	30,4	34,0	38,4
		COP	kW/kW	-	-	-	3,99	3,99	3,53
	HA2	Nominal capacity	kW	-	-	-	29,4	32,8	40,6
		COP	kW/kW	-	-	-	3,22	3,20	3,17
<b>Standard unit</b> Seasonal energy efficiency**	HA1	<b>SCOP<sub>30/35°C</sub></b>	<b>kW/kW</b>	-	-	-	<b>3,34</b>	<b>3,34</b>	<b>3,30</b>
		<b>η<sub>s heat</sub><sub>30/35°C</sub></b>	<b>%</b>	-	-	-	<b>131</b>	<b>131</b>	<b>129</b>
		<b>P<sub>rated</sub></b>	<b>kW</b>	-	-	-	20	23	31
		Energy labelling		-	-	-	A++	A++	A++
<b>Cooling</b>									
<b>Standard unit</b> Full load performances*	CA1	Nominal capacity	kW	27,5	33,5	41,5	26,4	32,5	39,4
		EER	kW/kW	3,12	3,32	2,99	2,98	3,19	2,88
	CA2	Nominal capacity	kW	38,9	46,2	57,1	34,2	43,2	54,4
		EER	kW/kW	4,03	4,15	3,55	3,61	3,92	3,46
<b>Standard unit</b> Seasonal energy efficiency**		<b>SEPR<sub>-2/-8°C</sub> Process medium temp.***</b>	<b>kWh/kWh</b>	<b>3,17</b>	<b>3,02</b>	<b>3,07</b>	-	-	-
		SEPR <sub>12/7°C</sub> Process high temp.	kWh/kWh	5,25	5,28	5,18	5,06	5,20	3,98
		SEER <sub>12/7°C</sub> Comfort low temp.	kWh/kWh	3,44	3,63	3,53	3,39	3,57	3,41
		SEER <sub>23/18°C</sub> Comfort medium temp.	kWh/kWh	3,96	4,08	4,04	3,87	4,02	3,96
Integrated Part Load Value	IPLV.SI	kW/kW	4,340	4,540	4,030	4,068	4,352	3,846	
<b>Operating weight<sup>(1)</sup></b>									
Standard unit, with hydraulic module			kg	255	280	291	280	295	305
Standard unit, without hydraulic module			kg	237	262	273	262	277	287
<b>Sound power level<sup>(2)</sup></b>			dB(A)	78	78	80	78	78	80
Sound pressure level at 10 m <sup>(3)</sup>			dB(A)	46	46	48	46	46	48

\* In accordance with standard EN14511-3:2022  
 \*\* In accordance with standard EN14825:2022, average climate  
 HA1 Heating mode conditions: Water heat exchanger water entering/leaving temperature 30°C/35°C, outside air temperature tdb/twb = 7°C db/6°C wb, evaporator frosting factor 0 m².K/W  
 HA2 Heating mode conditions: Water heat exchanger water entering/leaving temperature 40°C/45°C, outside air temperature tdb/twb = 7°C db/6°C wb, evaporator frosting factor 0 m².K/W  
 CA1 Cooling mode conditions: evaporator water entering/leaving temperature 12°C/7°C, outside air temperature 35°C, evaporator frosting factor 0 m².K/W  
 CA2 Cooling mode conditions: evaporator water entering/leaving temperature 23°C/18°C, outside air temperature 35°C, evaporator frosting factor 0 m².K/W  
**η<sub>s heat</sub><sub>30/35°C</sub> & SCOP<sub>30/35°C</sub>** **Bold values compliant to Ecodesign regulation: (EU) No 813/2013 for Heat Pump application**  
**SEPR<sub>-2/-8°C</sub>** **Bold values compliant to Ecodesign regulation: (EU) No 2015/1095 for Process application**  
**SEER<sub>12/7°C</sub> & SEPR<sub>12/7°C</sub>** Values calculated in accordance with EN14825:2022  
**SEER<sub>23/18°C</sub>** Values calculated in accordance with EN14825:2022  
 IPLV.SI Calculations according to standard performances AHRI 551-591 (SI)  
 (1) Weight shown is a guideline only. Please refer to the unit nameplate  
 (2) In dB ref=10<sup>-12</sup> W, (A) weighting. Declared dualnumber noise emission values in accordance with ISO 4871 (with an associated uncertainty of +/-3dB(A)). Measured in accordance with ISO 9614-1 and certified by Eurovent.  
 (3) In dB ref 20µPa, (A) weighting. Declared dualnumber noise emission values in accordance with ISO 4871 (with an associated uncertainty of +/-3dB(A)). For information, calculated from the sound power level Lw(A).



Eurovent certified values

## PHYSICAL DATA, 30RB / 30RQ UNITS

		30RB 26	30RB 33	30RB 40	30RQ 26	30RQ 33	30RQ 40
<b>Dimensions</b>							
Length	mm	1002					
Depth	mm	824					
Height	mm	1790					
<b>Compressor</b>		One hermetic scroll compressor					
<b>Refrigerant charge R-410A</b>	kg	5,8	8,6	8,8	7,6	9,5	9,8
	teqCO <sub>2</sub>	12,1	18,0	18,4	15,9	19,8	20,5
<b>Control</b>		Pro-Dialog+					
<b>Fans</b>		One twin-speed axial fan, 7 blades					
Diameter	mm	710					
Air flow	l/s	3530					
Speed	r/s	15					
<b>Water heat exchanger</b>		Plate heat exchanger, maximum operating pressure 1000 kPa					
<b>Water volume</b>	l	2,28	2,85	3,8	2,28	2,85	3,8
<b>Air heat exchanger</b>		Copper tubes and aluminum fins					
Pipe diameter	in	3/8	3/8	3/8	3/8	3/8	3/8
Number of rows		2	3	3	2,5	3	3
Number of pipes per row		60	60	60	60	60	60
Fin spacing	mm	1,69	1,69	1,69	1,69	1,69	1,69
<b>Standard unit</b>							
Water connections (MPT gas)	in	1-1/4					
<b>Unit with hydraulic module</b>		Pump, screen filter, expansion tank, flow switch, pressure gauge, automatic air purge valve, relief valve					
<b>Pump</b>		One single-speed pump, maximum water-side operating pressure 400 kPa					
Expansion tank capacity	l	8					
Entering water connection	in	1-1/4					
Leaving water connection	in	1-1/4					
Nominal operating current	A	2,4	2,6	2,8	2,4	2,6	2,8
<b>Chassis paint colour</b>		RAL 7035					

## ELECTRICAL DATA, 30RB/RQ UNITS

30RB/RQ		026	033	040
<b>Power circuit</b>				
Nominal power supply	V-ph-Hz	400-3+N-50 (power supply option C) or 400-3-50 (power supply option D)		400-3-50 (STD - no option)
Voltage range	V	340-460		360-440
<b>Control circuit supply</b>				
24 V via internal transformer				
<b>Maximum start-up current (Un)<sup>(1)</sup></b>	A	118	118	176
<b>Unit power factor at nominal capacity<sup>(2)</sup></b>		0,77	0,81	0,9
<b>Maximum operating power input<sup>(2)</sup></b>	kW	11	13,8	17,5
<b>Nominal current drawn<sup>(3)</sup></b>	A	16	17	25
<b>Maximum operating current draw (Un)<sup>(4)</sup></b>	A	20	24	30
<b>Maximum operating current draw (Un-15%)<sup>(5)</sup></b>	A	23	27	36

(1) Maximum instantaneous start-up current (locked rotor current of the compressor).

(2) Power input, compressors and fans, at the unit operating limits (saturated suction temperature 10°C, saturated condensing temperature 65°C) and nominal voltage of 400 V (data given on the unit nameplate).

(3) Standardised Eurovent conditions: Water heat exchanger entering/leaving water temperature 12°C/7°C, outside air temperature 35°C.

(4) Maximum unit operating current at maximum unit power input and 400 V (values given on the unit nameplate).

(5) Maximum unit operating current at maximum unit power input and 340-460V for sizes 026 to 033 or 360-440V for size 040.



## DIMENSIONS/CLEARANCES

### 30RB/RQ 026-040

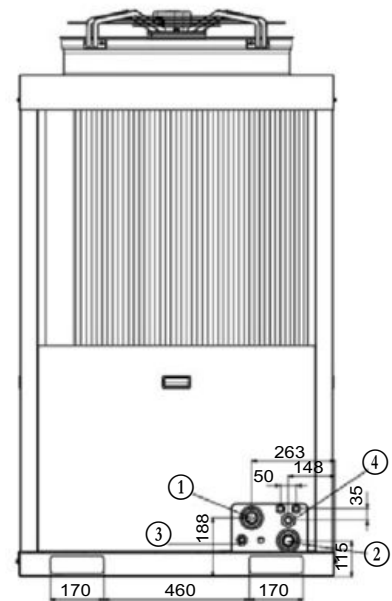
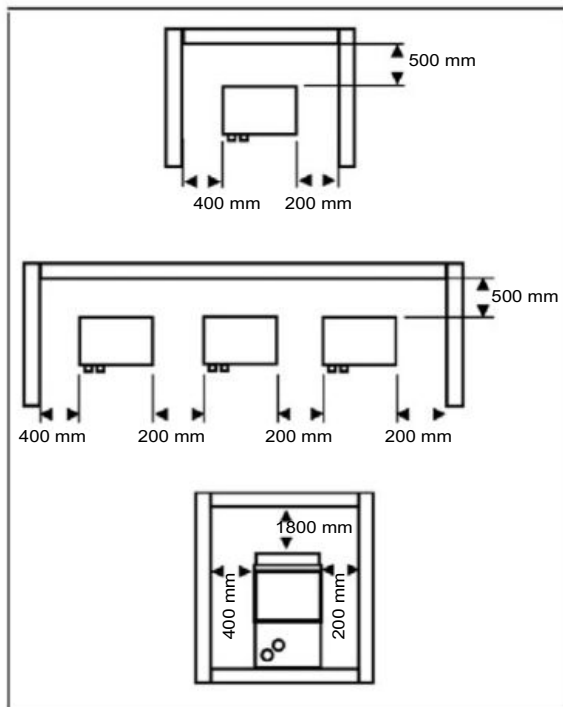
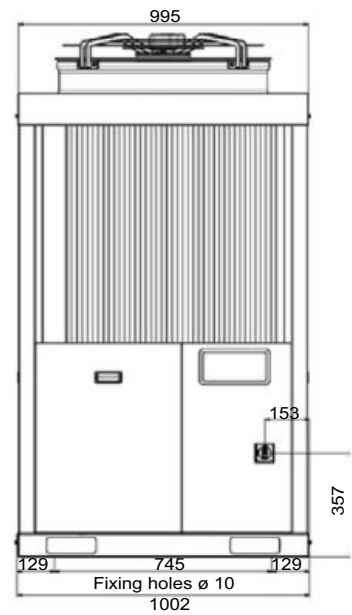
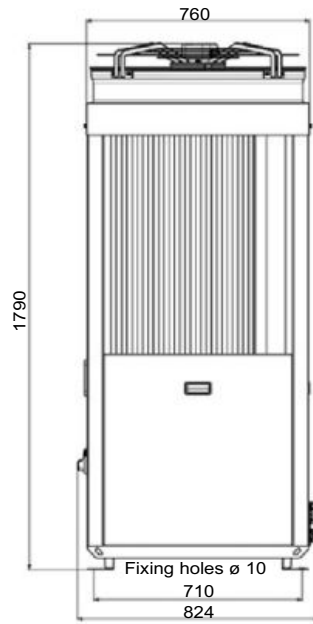
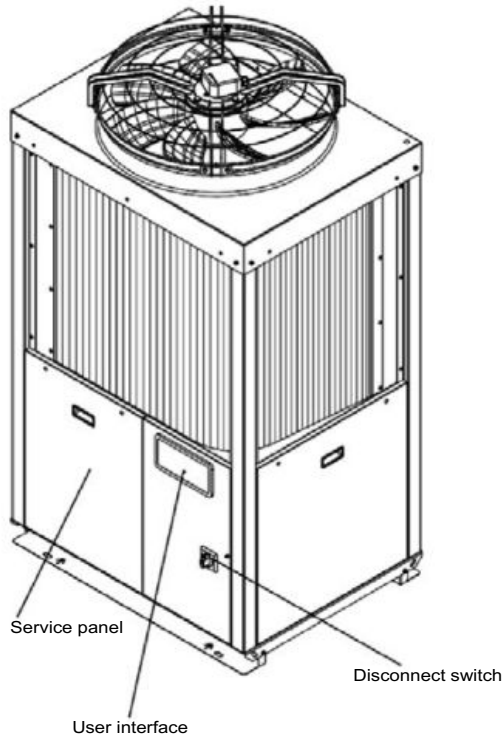

**Legend**

All dimensions are in mm

- ① Water inlet
- ② Water outlet
- ③ Water fill kit connection (option)
- ④ Power connections



## HIGH-TEMPERATURE MONOBLOC AIR-TO-WATER HEAT PUMPS WITH INTEGRATED HYDRAULIC MODULE



Unit with protection grille option



Heating system control (accessory)

61AF optimized for heating

Compact design

Plug & play approach

High temperature 65°C

# 61AF 030-105

Nominal heating capacity 26-102 kW 50 Hz

The AquaSnap high-temperature heat pump range was designed for commercial applications such as the heating of offices, apartments and hotels as well as domestic hot water production in new and refurbished buildings.

The main features of this product range are:

- Ease-of-installation

The high-temperature AquaSnap heat pumps incorporate an optional hydraulic module with a variable speed pump.

- Easy integration

The low noise levels of the 61AF heat pump and its very compact chassis reduce the noise disturbance from the unit.

- Application flexibility

The operating range allows outside temperatures down to -20°C and leaving water temperatures up to 65°C for domestic hot water applications.

- Availability

- Intelligent unit control permits unit operation in extreme conditions, minimising unit shut-down times.
- Hot water production at 65°C is available continuously.



CARRIER participates in the ECP programme for LCP-HP  
Check ongoing validity of certificate:  
[www.eurovent-certification.com](http://www.eurovent-certification.com)

## FEATURES AND BENEFITS

Carrier quality is your guarantee for the safety and durability of the installation.

The AquaSnap high-temperature heat pumps incorporate the latest technological features:

- Scroll compressors with vapour injection
- Low-noise fans made of a composite material
- Auto-adaptative microprocessor control
- Electronic expansion valve
- Variable speed.

The AquaSnap high-temperature heat pumps can be equipped with a hydraulic module that is integrated into the heat pump chassis, limiting the installation to straight-forward operations like the wiring and the connection of the hot water supply and return piping.

### Quiet operation

- Compressors
  - Low-noise scroll compressors with low vibration level.
  - The compressor assembly is installed on an independent chassis and supported by anti-vibration mountings.
  - Dynamic suction and discharge piping supports, minimising vibration transmission (Carrier patent).
- Evaporator section
  - Vertical evaporator coils
  - Anti-vibration mountings and optional grilles to protect the heat exchanger against possible shocks.
  - Latest-generation low-noise Flying Bird fans, made of a composite material (Carrier patent), are now even quieter and do not generate intrusive low-frequency noise.
  - Rigid fan installation for reduced start-up noise (Carrier patent).

### Easy and fast installation

- Integrated hydraulic module (option)
  - Variable speed pump, based on the pressure loss of the hydraulic installation.
  - Water filter protects the water pump against circulating debris.
  - Pump protected against cavitation by a pressure transducer that measures the entering water pressure.
  - Overpressure valve, set to 4 bar.
  - Thermal insulation and frost protection down to -20°C, using an electric resistance heater (see table of options).
- Physical features
  - The unit has a small footprint and a low height (1329 mm) allowing it to blend in with any architectural styles.
  - The unit is enclosed by easily removable panels, covering all components (except condensers and fans).
- Simplified electrical connections
  - Single power supply point without neutral.
  - Main disconnect switch with high trip capacity.
  - Transformer for safe 24 V control circuit supply included.
- Fast commissioning
  - Systematic factory operation test before shipment.
  - Quick-test function for step-by-step verification of the instruments, electrical components and motors.

### Economical operation

- Increased energy efficiency
  - The exceptional energy efficiency level (COP /SCOP) of the high-temperature AquaSnap heat pumps in the heating mode is the result of a long qualification and optimisation process.
  - The electronic expansion device (EXV) allows operation at a lower condensing pressure (COP optimisation).

- Dynamic superheat management for better utilisation of the condenser surface.
- Patented FreeDefrost algorithm without reverse the circuit in order to optimised energy during defrost and increase energy performance.

- Reduced maintenance costs
  - Maintenance-free scroll compressors with vapour injection.
  - SmartVu™ control offers fast diagnosis of possible incidents and their history.

### Environmental care

- Non-ozone depleting R-407C refrigerant
  - Chlorine-free refrigerant of the HFC group with zero ozone depletion potential.
  - Very efficient - ensures an increased energy efficiency ratio (COP).
  - Flying Bird IV fan

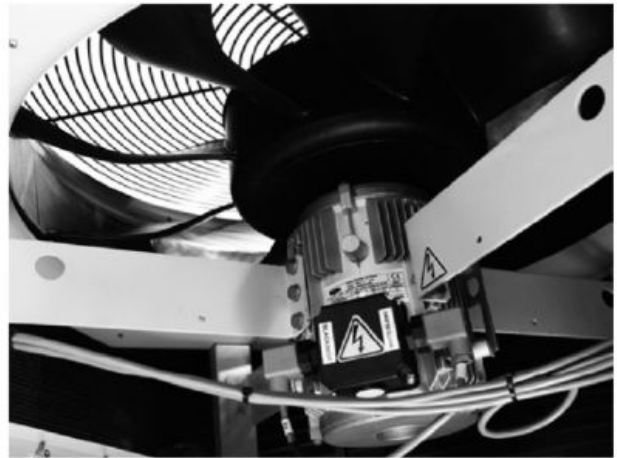

- Leak-tight refrigerant circuit
  - Brazed refrigerant connections for increased leak-tightness.
  - Reduction of leaks due to elimination of capillary tubes (TXVs).
  - Verification of pressure transducers and temperature sensors without transferring refrigerant charge.



Unit with protection grille option

## FEATURES AND BENEFITS

### Superior reliability

- State-of-the-art concept

Cooperation with specialist laboratories and use of limit simulation tools (finite element calculations) for the design of the critical components, e.g. motor supports, suction/discharge piping etc.

- Auto-adaptive control

Control algorithm prevents excessive compressor cycling and permits reduction of the water quantity in the hydraulic circuit (Carrier patent).

- Exceptional endurance tests

- Corrosion resistance tests in salt mist in the laboratory.
- Accelerated ageing test on components that are submitted to continuous operation: compressor piping, fan supports.
- Transport simulation test in the laboratory on a vibrating table.

### SmartVu™ control

The SmartVu™ control combines intelligence with operating simplicity. The control constantly monitors all machine parameters and precisely manages the operation of compressors, expansion devices, fans and the evaporator water pump for optimum energy efficiency.

The SmartVu™ control features advanced communication technology over Ethernet (IP) and a user-friendly and intuitive user interface with 4.3-inch colour touch screen.

- Energy management configuration

- Internal timer: Controls chiller on/off times and operation at a second setpoint
- Setpoint offset based on the outdoor air temperature
- Master/slave control of two chillers operating in parallel with runtime balancing and automatic changeover in case of a unit fault.
- For further energy savings, the AquaSnap® can be monitored remotely by Carrier experts for energy consumption diagnosis and optimisation.

- Integrated features

- Night mode: Capacity and fan speed limitation for reduced noise level
- With hydraulic module: Water pressure display and water flow rate calculation.

- Advanced communication features

- Easy and high-speed communication technology over Ethernet (IP) to a centralised building management system
- Access to multiple unit parameters.
- Maintenance functions
- F-Gas regulation leak check reminder alert
- Maintenance alert can be configured to days, months or hours of operation
- Storage of maintenance manual, wiring diagram and spare parts list
- Display of trend curves for the main values
- Management of a fault memory allowing a log of the last 50 incidents to be accessed, with operating readings taken when the fault occurs
- Blackbox memory

- 4"3 SmartVu™ user interface



- Intuitive and user-friendly 4"3 inch touch screen interface
- Concise and clear information is available in local languages
- Complete menu, customised for different users (end user, service personnel or Carrier engineers).

### Remote management (standard)

Units with SmartVu™ control can be easily accessed from the internet, using a PC with an Ethernet connection. This makes remote control quick and easy and offers significant advantage for service operations.

The AquaSnap® is equipped with an RS485 serial port that offers multiple remote control, monitoring and diagnostic possibilities. Carrier offers a vast choice of control products, specially designed to control, manage and supervise the operation of an air conditioning system. Please consult your Carrier representative for more information.

The AquaSnap® also communicates with other centralised building management systems via optional communication gateways.

A connection terminal allows the AquaSnap® unit to be remotely controlled by wire:

- Start/stop: Opening of this contact will shut down the unit
- Dual setpoint: Closing of this contact activates a second setpoint (e.g. unoccupied mode).
- Demand limit: Closing of this contact limits the maximum chiller capacity to a predefined value.
- Operation indication: This volt-free contact indicates that the chiller is operating (cooling load).
- Alarm indication: This volt-free contact indicates the presence of a major fault that has led to the shut-down of one or several refrigerant circuits.
- Setpoint adjustable via 4-20 mA signal



## OPTIONS AND ACCESSORIES

Options	No.	Description	Advantages	Use
Corrosion protection, traditional coils	3A	Fins made of pre-treated aluminium (polyurethane and epoxy)	Improved corrosion resistance, recommended for moderate marine and urban environments	61AF 030-105
Unit with ductable fans	11	Fans with 100 Pa maximum available pressure	Allows connection to discharge ducts in order to facilitate air evacuation	61AF 035-105
Low noise level	15	Aesthetic and sound absorbing compressor enclosure	Noise level reduction by 1 to 2 dB(A)	61AF 030-105
Very low noise level	15LS	Aesthetic and sound absorbing compressor enclosure associated with low-speed fans	Noise level reduction for sensible site	61AF 035-105
Protection grilles	23	Metallic protection grilles	Coil protection against possible impact	61AF 030-105
Soft Starter	25	Electronic starter on each compressor	Reduced start-up current	61AF 030-105
Water Exchanger frost protection	42	Electric heater on the hydraulic module	hydraulic module frost protection at low outside temperatures down to -20°C	61AF 030-105 with option 116X
Master/slave operation	58	Unit equipped with supplementary water outlet temperature sensor kit to be field-installed allowing master/slave operation of two units connected in parallel	Optimised operation of two units connected in parrallele operation with operating time equalisation	61AF 030-105
LP VSD single-pump	116X	Variable speed single pump, For more details, refer to the dedicated chapter (expansion tank not included)	Easy and fast installation (plug & play), significant pumping energy cost savings (more than two-thirds), tighter water flow control, improved sytem reliability	61AF 030-105
J-Bus gateway	149B	Two-directional communication board complying with JBus protocol	Connects the unit by communication bus to a building management system	61AF 030-105
Lon gateway	148D	Two-directional communication board complying with Lon Talk protocol	Connects the unit by communication bus to a building management system	61AF 030-105
Bacnet over IP	149	Two-directional high-speed communication using BACnet protocol over Ethernet network (IP)	Easy and high-speed connection by ethernet line to a building management system. Allows access to multiple unit parameters	61AF 030-106
Compliance with Russian regulations	199	EAC certification	Conformance with Russian regulations	61AF 030-105
Condenser screw connection sleeves kit	265	Condenser inlet/outlet screw connection sleeves	Allows unit connection to a screw connector	61AF 030-105
Welded condenser water connection kit	267	Victaulic piping connections with welded joints	Easy installation	61AF 035-105
Set-point adjustment by 4-20mA signal	311	Connections to allow a 4-20mA signal input	Easy energy managment, allow to adjust set-point by a 4-20mA external signal	61AF 030-105
Plastic tarp	331	Plastic sheeting covering the units, with strapping securing it on the wooden pallet.	Allow unit to avoid dust and dirt from the outside environment during stocking and shipping.	61AF 030-105

Accessories	Description	Advantages	Use
00PPG000488000- Heating System Manager type A: controls one heat emitter type with an auxiliary electric heater or boiler	Additional control box not supplied with the unit, to be installed remotely	Heating system control facilitated	61AF 030-105
00PPG000488100- Heating System Manager type B: controls two heat emitter types (or independent zones) and domestic hot water production with an auxiliary electric heater or boiler	Additional control box not supplied with the unit, to be installed remotely	Heating system control facilitated	61AF 030-105
00PPG000488200- Heating System Manager type C: controls two heat emitter types (or independent zones) and domestic hot water production with a district heating system as auxiliary source	Additional control box not supplied with the unit, to be installed remotely	Heating system control facilitated	61AF 030-105

## OPTIONS AND ACCESSORIES

Units with fans with available pressure for indoor installation (option 11)

This option applies to 61AF units installed inside the building in a plant room. For this type of installation the cold air leaving the air-cooled evaporators is discharged by the fans to the outside of the building, using a duct system.

The installation of a duct system at the air evaporator discharge line causes a pressure drop due to the resistance caused by the air flow.

Therefore more powerful fan motors than those used for the standard units are installed in the units with this option. For each installation of a unit installed inside a plant room the duct pressure drops differ, depending on the duct length, duct section and direction changes.

61AF units equipped with fans with available pressure are designed to operate with air discharge ducts with maximum pressure drops of 100 Pa.

### Fan discharge connection

A square flange is supplied mounted on the unit. An available standard round flange can easily be installed at the fan discharge, if the installer prefers the use of a round connection duct.

The unit is supplied with a grille on the discharge side. This grille has to be removed before connection to the duct system.

It is advisable to make the connection to the duct system with a flexible sleeve. If this recommendation is not observed, a lot of vibration and noise may be transmitted to the building structure.

Applicable rules for units incorporated into an air duct system

Ensure that the suction or discharge inlets are not accidentally obstructed by the panel positioning (e.g. low return or open doors etc.).

### Electrical data for 61AF units with option 11

61AF - unit with option 11 (without hydraulic module)		035	045	055	075	105
<b>Power circuit</b>						
Nominal power supply	V-ph-Hz	400-3-50				
Voltage range	V	360-440				
<b>Control circuit supply</b>		24 V, via internal transformer				
<b>Maximum start-up current (Un)<sup>(1)</sup></b>						
Standard unit	A	131	171	203	160	244
Unit with electronic starter option	A	70	91	103	99	147
<b>Unit power factor at maximum capacity<sup>(2)</sup></b>		0,83	0,87	0,87	0,83	0,87
<b>Maximum unit power input<sup>(2)</sup></b>	kW	16	20	24	33	49
<b>Nominal unit current draw<sup>(3)</sup></b>	A	22	25	29	43	58
<b>Maximum unit current draw (Un)<sup>(4)</sup></b>	A	29	34	40	57	81
<b>Maximum unit current draw (Un-10%) *</b>	A	31	37	44	62	87
<b>Customer-side unit power reserve</b>		Customer reserve at the 24V control power circuit				
<b>Short-circuit stability and protection</b>		See table on page 12				

(1) Maximum instantaneous start-up current (maximum operating current of the compressor + fan current + locked rotor current of the compressor).

(2) Power input, compressor and fan, at the unit operating limits (saturated suction temperature 10°C, saturated condensing temperature 65°C) and nominal voltage of 400V (data given on the unit nameplate).

(3) Standardised Eurovent conditions: evaporator entering/leaving water temperature 40°C/45°C, outside air temperature db/wb = 7°C/6°C.

(4) Maximum unit operating current at maximum unit power input and 400V (values given on the unit nameplate).

\* Maximum unit operating current at maximum unit power input and 360V.

## PHYSICAL DATA

61AF			030	035	045	055	075	105	
<b>Heating</b>									
<b>Standard unit</b> Full load performances*	HA1	Nominal capacity	kW	25,9	32,3	43,5	51,6	64,8	102
		COP	kW/kW	3,99	3,99	4,32	4,36	3,99	4,26
	HA2	Nominal capacity	kW	25,4	32,0	43,0	51,7	66,8	102
		COP	kW/kW	3,34	3,32	3,60	3,67	3,43	3,59
	HA3	Nominal capacity	kW	25,00	31,50	42,70	52,30	68,00	102,00
		COP	kW/kW	2,90	2,88	3,14	3,19	3,01	3,13
	HA4	Nominal capacity	kW	24,50	31,30	42,70	53,30	68,00	103,00
		COP	kW/kW	2,43	2,42	2,64	2,68	2,54	2,64
<b>Standard unit</b> Seasonal energy efficiency**	HA1	SCOP <sub>30/35°C</sub>	kWh/kWh	3,33	3,44	3,58	3,66	3,57	3,62
		ηs heat <sub>30/35°C</sub>	%	130	135	140	143	140	142
	HA3	SCOP <sub>47/55°C</sub>	kWh/kWh	<b>2,93</b>	<b>2,94</b>	<b>3,10</b>	<b>3,15</b>	<b>3,00</b>	<b>3,16</b>
		ηs heat <sub>47/55°C</sub>	%	<b>114</b>	<b>115</b>	<b>121</b>	<b>123</b>	<b>117</b>	<b>123</b>
		P <sub>rated</sub>	kW	19,00	31,00	43,00	55,00	63,00	94,00
		Energy labelling		A+	A+	A+	A+	A+	-
<b>Operating weight<sup>(1)</sup></b>									
Standard unit (without hydraulic module)		kg	409	426	540	564	904	1024	
Standard unit (with hydraulic module option)		kg	418	435	555	579	919	1039	
<b>Sound levels</b>									
Sound power level <sup>(2)</sup>		dB(A)	78	83	82	84	84	85	
Sound pressure level at 10 m <sup>(3)</sup>		dB(A)	46	51	51	53	52	53	
<b>Dimensions</b>									
Length		mm	1110		1114		2273		
Depth		mm	1327		2100		2100		
Height		mm	1330		1330		1330		
<b>Compressor</b>		Hermetic scroll compressors, 48,3 r/s							
Quantity			1	1	1	1	2	2	
Number of capacity stages			1	1	1	1	2	2	
<b>Refrigerant</b>		R407C GWP = 1800 following AR4							
Charge		kg	8,8	9,7	10	13,2	22	26,5	
		teqCO <sub>2</sub>	15,6	17,2	17,7	23,4	39,0	47,0	
<b>Capacity control</b>		SmartVu™							
Minimum capacity		%	100	100	100	100	50	50	

- \* In accordance with standard EN14511-3:2022
- \*\* In accordance with standard EN14825:2022, average climate
- HA1 Heating mode conditions: Water heat exchanger water entering/leaving temperature 30°C/35°C, outside air temperature tdb/twb = 7°C db/6°C wb, evaporator fouling factor 0 m<sup>2</sup>.K/W
- HA2 Heating mode conditions: Water heat exchanger water entering/leaving temperature 40°C/45°C, outside air temperature tdb/twb = 7°C db/6°C wb, evaporator fouling factor 0 m<sup>2</sup>.K/W
- HA3 Heating mode conditions: Water heat exchanger water entering/leaving temperature 47°C/55°C, outside air temperature tdb/twb = 7°C db/6°C wb, evaporator fouling factor 0 m<sup>2</sup>.K/W
- HA4 Heating mode conditions: Water heat exchanger water entering/leaving temperature 55°C/65°C, outside air temperature tdb/twb = 7°C db/6°C wb, evaporator fouling factor 0 m<sup>2</sup>.K/W
- ηs heat<sub>30/35°C</sub> & SCOP<sub>30/35°C</sub> Values calculated in accordance with EN14825:2022
- ηs heat<sub>47/55°C</sub> & SCOP<sub>47/55°C</sub> **Bold values compliant to Ecodesign regulation: (EU) No 813/2013 for Heat Pump application**
- Not applicable
- (1) Weight shown is a guideline only. Please refer to the unit nameplate
- (2) In dB ref=10<sup>-12</sup> W, (A) weighting. Declared dualnumber noise emission values in accordance with ISO 4871 (with an associated uncertainty of +/-3dB(A)). Measured in accordance with ISO 9614-1 and certified by Eurovent.
- (3) In dB ref 20μPa, (A) weighting. Declared dualnumber noise emission values in accordance with ISO 4871 (with an associated uncertainty of +/-3dB(A)). For information, calculated from the sound power level Lw(A).



Eurovent certified values

## PHYSICAL DATA

61AF		030	035	045	055	075	105
<b>Condenser</b>		Direct expansion, plate heat exchanger					
Water volume	l	6,4	8,2	9,6	12,1	16,4	22,7
Max. water-side operating pressure without hydraulic module	kPa	1000	1000	1000	1000	1000	1000
Max. water-side operating pressure plus hydraulic module	kPa	400	400	400	400	400	400
<b>Fan</b>		Axial Flying Bird IV with rotating shroud					
Quantity		1	1	1	1	2	2
Maximum total air flow	l/s	3748	3736	4035	4036	7479	8072
Max speed, standard unit	tr/s	12	12	12	12	12	12
Max speed, unit with option 11	tr/s	-	16	16	16	16	16
<b>Evaporator</b>		Grooved copper tubes and aluminium fins					
<b>Hydraulic module (option 116)</b>							
Variable speed pump		Pump, Victaulic screen filter, relief valve, purge valves (water and air), cavitation pressure sensors					
<b>Water connections with / without hydraulic module</b>		Victaulic					
Connections	inch	1"1/4	1"1/2	1"1/2	1"1/2	2	2
Outside diameter	mm	42,4	48,3	48,3	48,3	60,3	60,3
<b>Chassis paint colour</b>		Colour code RAL7035					

## ELECTRICAL DATA

61AF - standard unit (without hydraulic module)		030	035	045	055	075	105
<b>Power circuit</b>							
Nominal power supply	V-ph-Hz	400-3-50					
Voltage range	V	360-440					
<b>Control circuit supply</b>							
24 V, via internal transformer							
<b>Maximum start-up current (Un)<sup>(1)</sup></b>							
Standard unit	A	101	129	169	201	157	241
Unit with electronic starter option	A	54	68	89	101	94	142
<b>Unit power factor at maximum capacity<sup>(2)</sup></b>							
		0,82	0,83	0,87	0,87	0,83	0,87
<b>Maximum unit power input<sup>(2)</sup></b>							
		11	15	19	23	30	46
<b>Nominal unit current draw<sup>(3)</sup></b>							
		16	19	23	28	39	55
<b>Maximum unit current draw (Un)<sup>(4)</sup></b>							
		20	26	32	38	53	76
<b>Maximum unit current draw (Un-10%) *</b>							
		22	29	35	42	57	83
<b>Customer-side unit power reserve</b>							
Customer reserve at the 24 V control power circuit							
<b>Short-circuit stability and protection</b>							
See table below.							

- (1) Maximum instantaneous start-up current (maximum operating current of the compressor + fan current + locked rotor current of the compressor).  
 (2) Power input, compressor and fan, at the unit operating limits (saturated suction temperature 10°C, saturated condensing temperature 65°C) and nominal voltage of 400V (data given on the unit nameplate).  
 (3) Standardised Eurovent conditions: evaporator entering/leaving water temperature 40°C/45°C, outside air temperature db/wb = 7°C/6°C.  
 (4) Maximum unit operating current at maximum unit power input and 400V (values given on the unit nameplate).  
 \* Maximum unit operating current at maximum unit power input and 360V.

### Short-circuit stability current, main disconnect without fuse (TN system<sup>(1)</sup>)

61AF - standard unit (main disconnect switch)		030	035	045	055	075	105
<b>Value with unspecified upstream protection</b>							
Short-term current at 1 s (I <sub>cw</sub> )	kA rms	0,6	0,6	1,26	1,26	1,26	2
Admissible peak current (I <sub>pk</sub> )	kA pk	4,5	4,5	6	6	6	10
<b>Maximum value with upstream protection by circuit breaker</b>							
Conditional short-circuit current (I <sub>cc</sub> )	kA rms	7	7	7,7	7,7	6,1	10
Circuit breaker - Compact range		40	40	50	63	80	100
Reference number <sup>(2)</sup>		5SY6340-7	5SY6340-7	5SY4350-7	5SY4363-8	5SP4380-7	5SP4391-7
<b>Maximum value with upstream protection by fuses (gL/gG)</b>							
Conditional short-circuit current (I <sub>cc</sub> )	kA rms	50	50	50	50	14,5	22
Fuse (gL/gG)		40	40	63	63	80	125

- (1) Earthing system type  
 (2) If another current limitation protection system is used, its time-current and thermal constraint (I<sup>2</sup>t) trip characteristics must be at least equivalent to those of the recommended circuit breaker.  
 The short-circuit stability current values above are suitable with the TN system.

#### Electrical data and operating conditions notes:

- 61AF 030-105 units have a single power connection point located immediately upstream of the main disconnect switch.
- The control box includes the following standard features:
  - A main disconnect switch,
  - Starter and motor protection devices for each compressor, the fans and the pump,
  - The control devices.
- Field connections:**  
All connections to the system and the electrical installations must be in full accordance with all applicable local codes.
- The Carrier 61AF units are designed and built to ensure conformance with these codes. The recommendations of European standard EN 60204-1 (machine safety - electrical machine components - part 1: general regulations - corresponds to IEC 60204-1) are specifically taken into account, when designing the electrical equipment.

#### NOTES:

- Generally the recommendations of IEC 60364 are accepted as compliance with the requirements of the installation directives. Conformance with EN 60204-1 is the best means of ensuring compliance with the Machines Directive § 1.5.1.
- Annex B of EN 60204-1 describes the electrical characteristics used for the operation of the machines.

- The operating environment for the 61AF units is specified below:

- Environment<sup>(1)</sup> - Environment as classified in EN 60721 (corresponds to IEC 60721):
  - Outdoor installation<sup>(1)</sup>
  - Ambient temperature range: -20°C to +40°C, class 4K4H
  - Altitude: ≤ 2000 m
  - Presence of hard solids, class 4S2 (no significant dust present)
  - Presence of corrosive and polluting substances, class 4C2 (negligible)
- Power supply frequency variation: ± 2 Hz.
- The neutral (N) conductor must not be connected directly to the unit (if necessary use a transformer).
- Overcurrent protection of the power supply conductors is not provided with the unit.
- The factory-installed disconnect switch is of a type suitable for power interruption in accordance with EN 60947.
- The units are designed for connection to TN networks (IEC 60364). For IT networks the earth connection must not be at the network earth. Provide a local earth, consult competent local organisations to complete the electrical installation. Units delivered with speed drive (options 116) are not compatible with IT network.

**Caution: If particular aspects of an actual installation do not conform to the conditions described above, or if there are other conditions which should be considered, always contact your local Carrier representative.**

- (1) The required protection level for this class is IP43BW (according to reference document IEC 60529). All 61AF units are protected to IP44CW and fulfil this protection condition.



## DIMENSIONS/CLEARANCES

### 61AF 030-035 units with and without hydraulic module

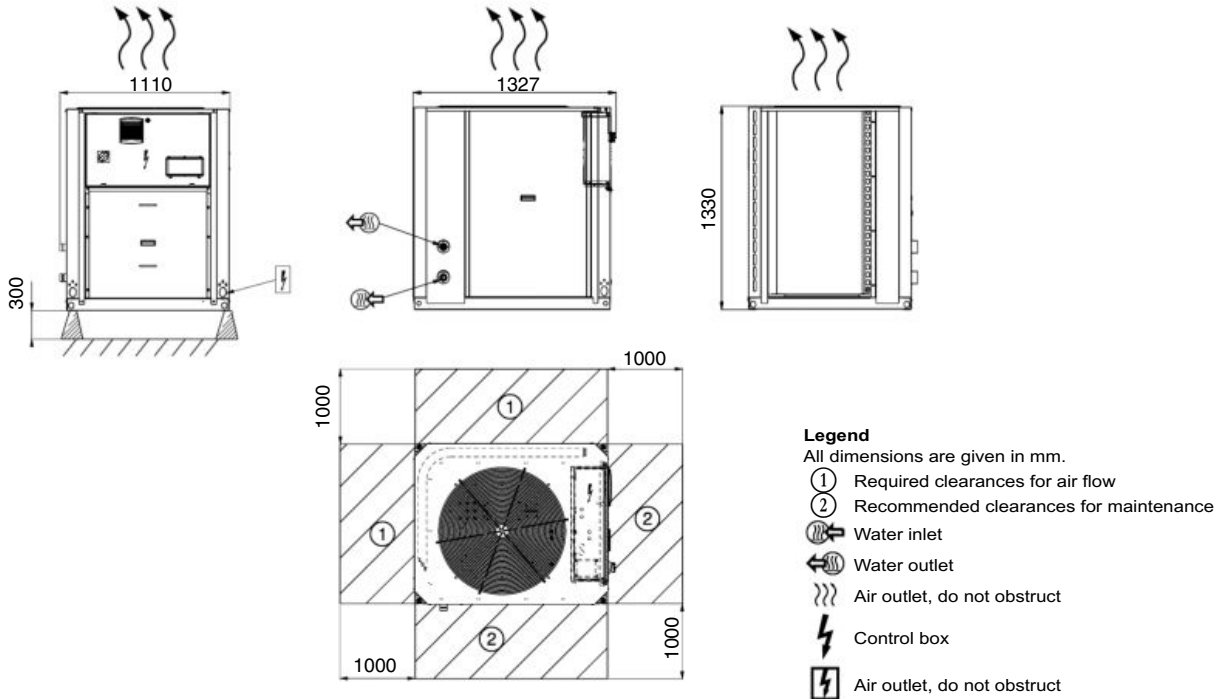

### 61AF 045-055 units with and without hydraulic module

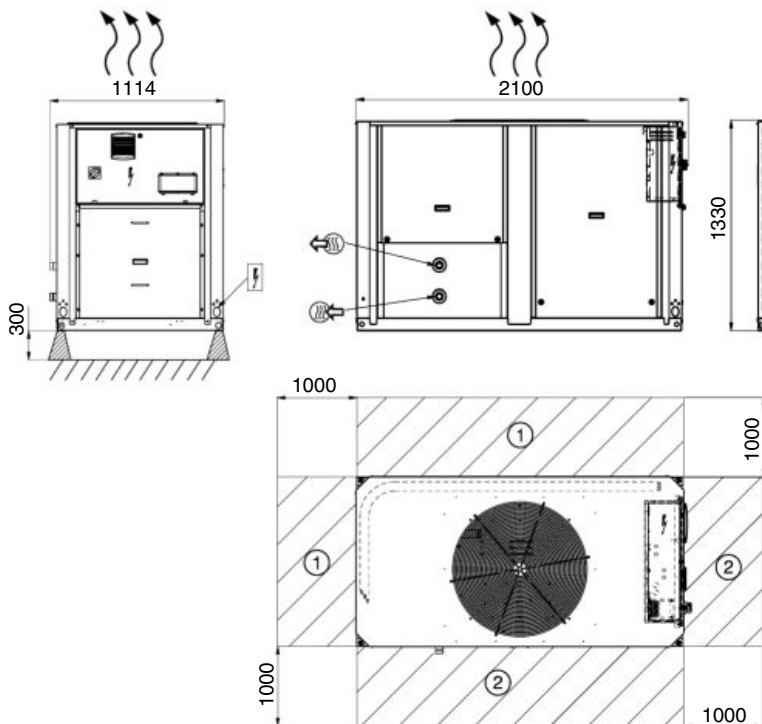

**NOTES:**

**A Non-certified drawings.**

Refer to the certified dimensional drawings supplied with the unit or available on request, when designing an installation. For the location of fixing points, weight distribution and coordinates of the centre of gravity refer to the certified dimensional drawings.

**B In multiple-unit installations (maximum four units), the side clearance between the units should be increased from 1000 to 2000 mm.**

**C The height of the solid surface must not exceed 2 m.**

**DIMENSIONS/CLEARANCES**

**61AF 075-105 units with and without hydraulic module**

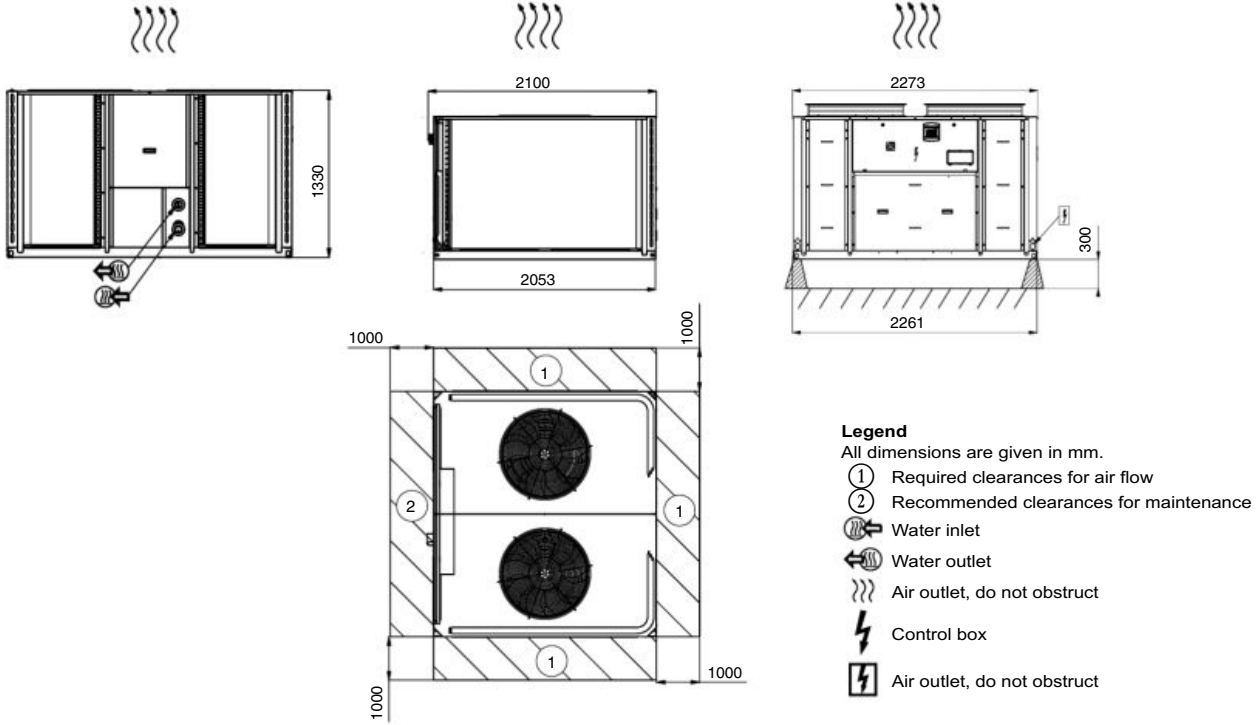

**61AF 035 with option 11, units with and without hydraulic module**

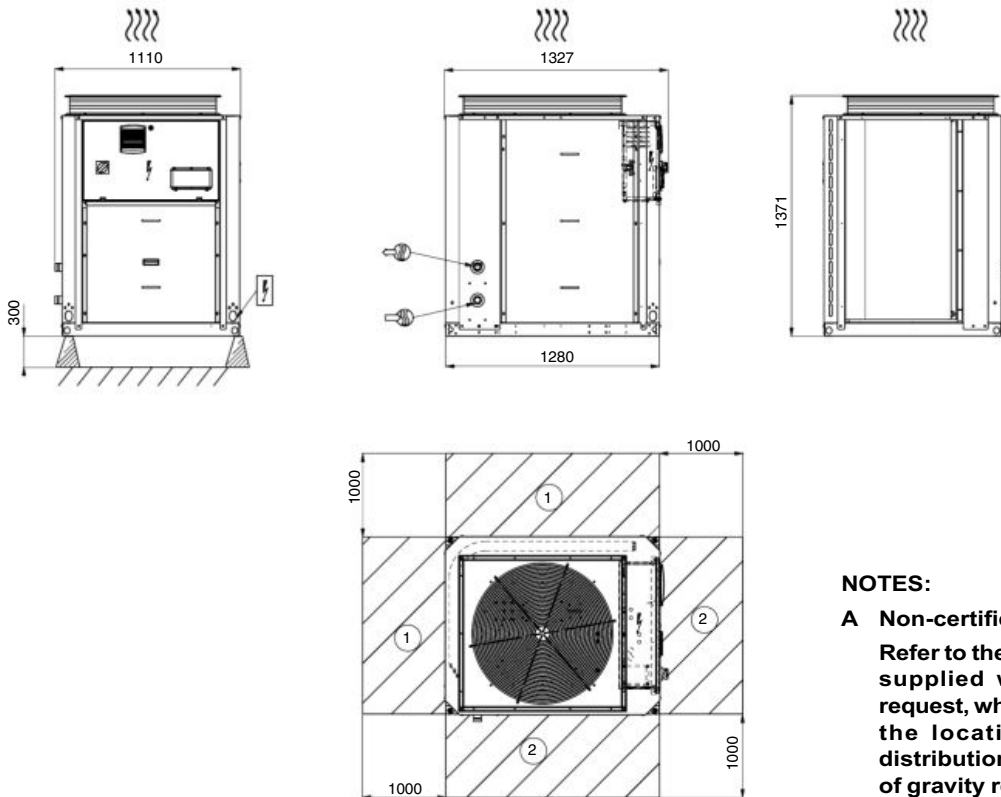

**NOTES:**

- A Non-certified drawings.**  
 Refer to the certified dimensional drawings supplied with the unit or available on request, when designing an installation. For the location of fixing points, weight distribution and coordinates of the centre of gravity refer to the certified dimensional drawings.
- B In multiple-unit installations (maximum four units), the side clearance between the units should be increased from 1000 to 2000 mm.**
- C The height of the solid surface must not exceed 2 m.**

## DIMENSIONS/CLEARANCES

### 61AF 045-055 with option 11, units with and without hydraulic module

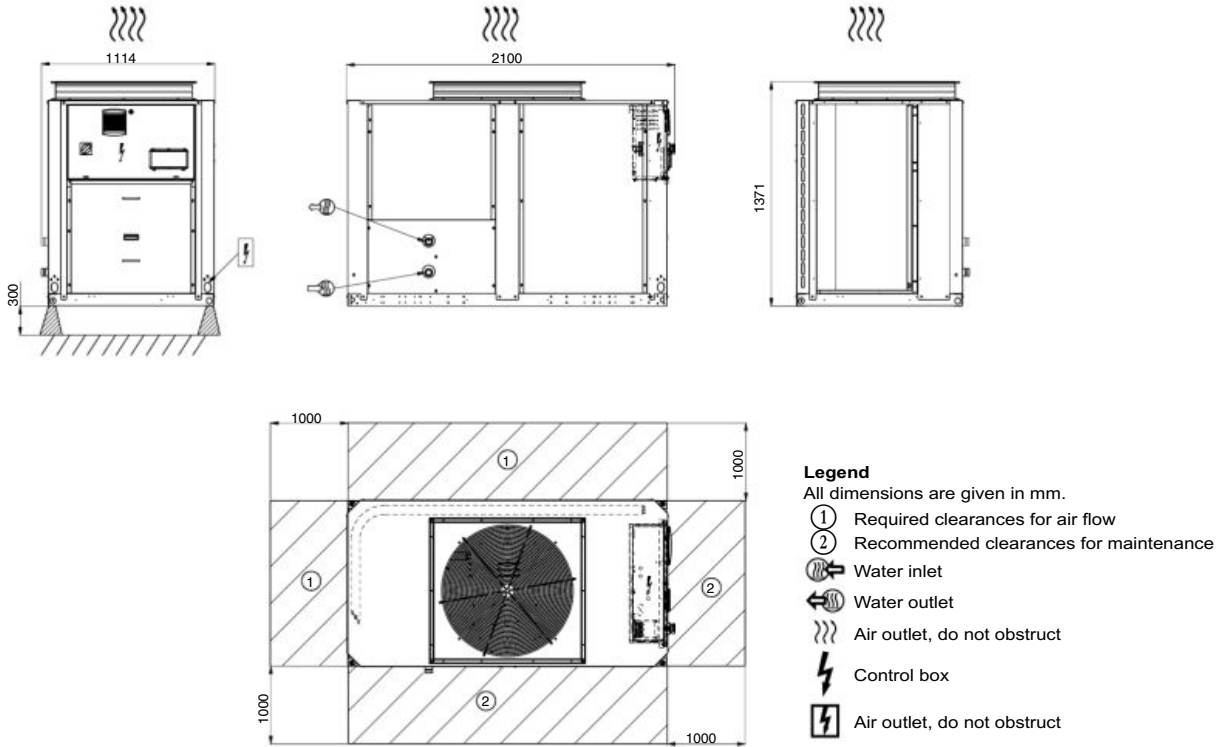

### 61AF 075-105 with option 11, units with and without hydraulic module

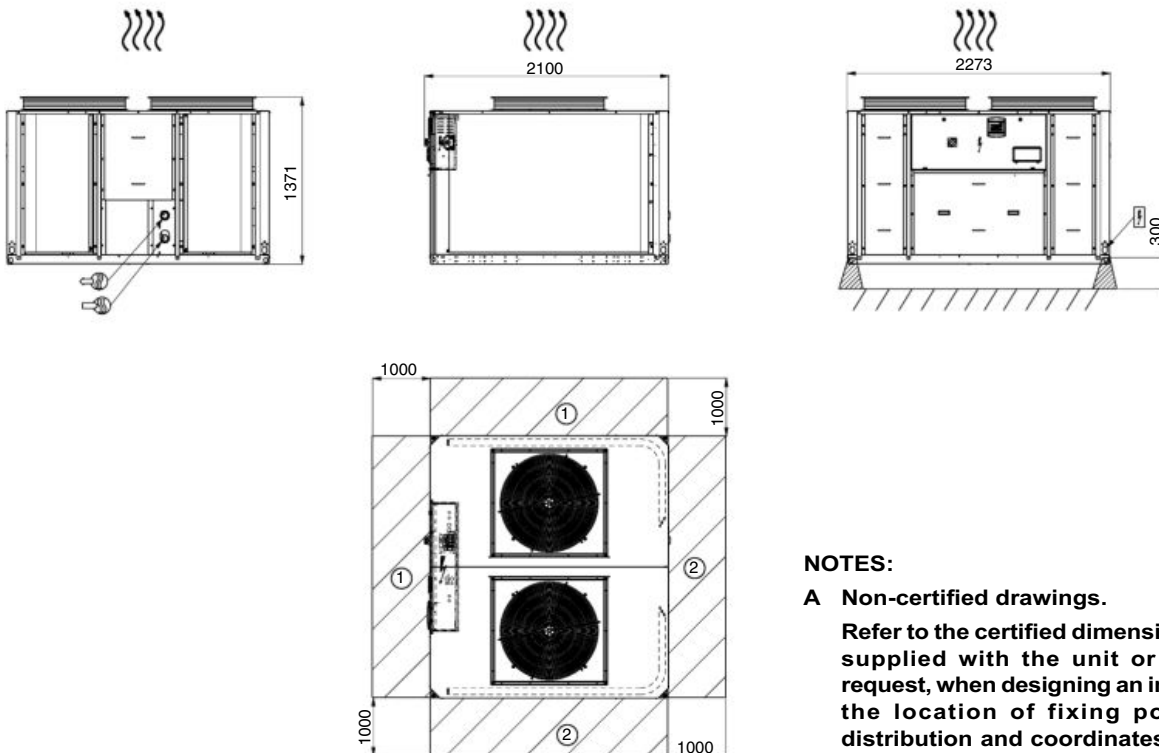

**NOTES:**

**A Non-certified drawings.**

Refer to the certified dimensional drawings supplied with the unit or available on request, when designing an installation. For the location of fixing points, weight distribution and coordinates of the centre of gravity refer to the certified dimensional drawings.

**B In multiple-unit installations (maximum four units), the side clearance between the units should be increased from 1000 to 2000 mm.**

**C The height of the solid surface must not exceed 2 m.**



**NEW**

## HIGH TEMPERATURE HEAT PUMP WITH SCROLL COMPRESSOR



# 61CG

Nominal heating capacity 30-130 kW  
HFC R-134a

### APPLICATION RANGES

- Heat recovery in hotels, food-processing and pharmaceutical industries, energy supply, data centres
- Hygienically critical hot water applications in hospitals, retirement homes
- Booster solution in combination with low temperature heating
- Heat sources: water or brine

### DESIGN

- Compact, space saving design
- High source temperatures between +10°C and +42°C
- High level leaving temperature up to 82°C

### OUTPUT RANGE

- Heating output from 30 kW to 130 kW; cascade up to 390 kW

## AQUASNAP.





## TECHNICAL INSIGHT

### COMPRESSOR

The fully hermetic scroll compressors have been designed especially for use in high temperature heat pump applications. Various important design measures protect the compressor both under standard working conditions and when overloaded. The compressors used in 61CG are the most powerful and highest resistance compressors.

Scroll compressors have only a few moving parts and no dynamic suction or pressure valves. They are also noted for their particularly low vibration and sound levels.

Compressors are equipped in standard with an electronic soft-starter in order to reduce the starting current

### HEAT EXCHANGER

Brazed plate heat exchanger in stainless steel, direct expansion.

Sized especially for the relevant application.

### REFRIGERANT CIRCUIT

Fully hermetic scroll compressor with double pressure compensation for optimum efficiency, suitable for flow temperatures up to 82°C.

Built-in overload protection and additional field rotation monitoring.

Gas phase manager for highest operational reliability of the compressor and maximum utilisation of heat source energy.

Large liquid receiver, thermostatically controlled expansion valve with external pressure compensation, filter dryer, sight glass.

Electronic refrigerant expansion valve for maximum efficiency in all heat pump operating conditions.

Refrigerant circuit optimised, thermally insulated, and charged with R-134a CFC, non-combustible and non-toxic heat transfer medium.

Biodegradable compressor oil.

### SAFETY EQUIPMENT

#### Compressor protection device. It monitors:

- Motor and oil temperatures
- Rotational direction
- Phase failure

#### Additional safety equipment

- Permanent monitoring of the limits of use via the compressor operating envelope
- Overpressure safety valve

### CONTROL UNIT

The hardware of the control unit comprises a programmable logic controller (PLC) and a Human Machine Interface (HMI). The software for the control unit was developed especially for 61CG and processes the necessary number of inputs and outputs for controlling the refrigerant circuit.

The control also performs all non-mechanical safety functions of the refrigerant circuit, e.g.: frost protection alarm or field rotation monitoring on the compressor motor.

The HMI has a 10" touchscreen for entering control commands, target values and parameters. For visualisation of system statuses and actual values, these can be represented on a hydraulic schematic on the display.

Via pop-up menus, detailed information on various components of the heat pump can be called up.

Any alarms are displayed. All measured values are continuously monitored by the control in real time. Interfaces for remote maintenance or a higher level BMS are available.

Modbus gateway interface (RS485 RTU type)

#### Controller functions/safety functions:

- Long-term recording of operating conditions
- Hours run counter for compressor
- Monitoring of minimum compressor downtime and runtime
- Actuation of solenoid valves for output control
- Management of actuated component alarms
- Heating/cooling mode changeover
- Remote monitoring/control via internet (optional)

#### Temperature control:

The heat pump can provide various temperatures at the condenser or evaporator outlet depending on demand.

The following options are available for such temperature requirements:

- Fixed target value
- 0-10 V analogue input
- Via Modbus, (optional)
- Outdoor temperature guided (heating curve), incl. outdoor temperature sensor

#### Control mode:

The heat pump is operated with a heating mode priority (standard version) or cooling mode priority (optional).

#### Operating modes:

The heat pump can be optimised for the following operating modes:

- Heating mode
- Cooling mode
- DHW heating
- Heating and cooling (parallel)

#### Additional control functions can be implemented (on request):

- Power supply and actuation of the circulation pumps for heat source and/or user loop
- Buffer tank control strategy (DHW)
- Power supply and actuation of the 3-way mixing valves on the evaporator and/or condenser

### UNIT CONSTRUCTION:

61CG Series is extremely quiet in operation thanks to 3-fold elastic double-L frame construction.

Soundproofing box, self-supporting, made of solid enamelled steel sheet, with sound absorption device, easily accessible from all sides.

A durable sound insulation underlay is included.

Colour: grey RAL 7016

### ACCEPTANCE REPORT

Test run on the factory test bench, in the presence of the customer on request.

## PHYSICAL DATA

Unit		61CG-A030	61CG-A040	61CG-A060	61CG-A080	61CG-A100	61CG-A130
<b>Performance data<sup>(1)</sup></b>							
Heating Capacity	kW	19,4	26,0	32,4	51,2	63,6	78,4
Cooling Capacity	kW	12,3	17,2	20,9	32,9	40,9	51,3
Power Consumption	W20/ W70 kW	7,1	8,8	11,6	18,3	22,7	27,1
Coefficient of Performance	-	2,7	3,0	2,8	2,8	2,8	2,9
Drawn Current	A	12,9	15,5	20,6	30,1	38,9	44,6
Heating Capacity	kW	31,5	41,3	51,7	79,1	98,5	122,0
Cooling Capacity	W40/ W80 kW	22,8	30,4	37,4	56,2	70,4	87,9
Power Consumption	kW	8,7	10,9	14,3	22,9	28,1	34,1
Coefficient of Performance	-	3,6	3,8	3,6	3,5	3,5	3,6
Drawn Current	A	15,0	18,4	24,3	37,5	45,9	54,5
<b>Technical data</b>							
Dimensions (LxWxH) <sup>(2)</sup>	mm	680 x 890 x 1890	680 x 890 x 1890	680 x 890 x 1890	680 x 890 x 1890	680 x 890 x 1890	680 x 730 x 1890 <sup>(3)</sup>
Weight <sup>(2)</sup>	kg	310	320	330	450	490	510
Refrigerant	-	R134a (GWP=1430 following AR 4, ODP=0)					
Refrigerant charge <sup>(2)</sup>	kg	11	11	15,5	15,5	18	18
	teqCO <sub>2</sub>	15,7	15,7	22,2	22,2	25,7	25,7
Oil charge	l	2,7	3,4	3,4	4,7	6,8	6,3
Voltage / Frequency	V/Hz	400/50					
Rotor starting current	A	47,5	59	70	112,5	136	155
Max. Operating current	A	16,4	20,7	27,1	42,9	52,8	62,9
<b>Compressor</b>							
Quantity	-	1	1	1	1	1	1
Type	-	Scroll-Compressor					
Capacity Control	-	1 ( 0% or 100% )					
<b>Evaporator</b>							
Temperature difference <sup>(4)</sup>	K	4	4	4	4	4	4
Water flow <sup>(4)</sup>	m <sup>3</sup> /h	5,0	6,6	8,1	12,2	15,3	19,1
Internal pressure drop <sup>(4)</sup>	mbar	90	80	90	170	200	110
Fluid type	-	Water	Water	Water	Water	Water	Water
Minimum flow rate	m <sup>3</sup> /h	2,5	2,5	4,2	4,2	7,9	7,9
Maximum flow rate	m <sup>3</sup> /h	9,0	13,8	18,9	24,0	24,0	35,0
Operating range - Inlet temperature	°C	+10/+42	+10/+42	+10/+42	+10/+42	+10/+42	+10/+42
Min. operating pressure	bar	1,0	1,0	1,0	1,0	1,0	1,0
Max. operating pressure	bar	6,0	6,0	6,0	6,0	6,0	6,0
<b>Condenser</b>							
Temperature difference <sup>(4)</sup>	K	5	5	5	5	5	5
Water flow <sup>(4)</sup>	m <sup>3</sup> /h	5,6	7,3	9,1	14,0	17,4	21,5
Internal pressure drop <sup>(4)</sup>	mbar	120	90	100	220	260	115
Fluid type	-	Water	Water	Water	Water	Water	Water
Minimum flow rate	m <sup>3</sup> /h	2,8	2,8	4,5	4,5	8,9	8,9
Maximum flow rate	m <sup>3</sup> /h	9,0	15,1	18,9	24,0	24,0	35,0
Operating range - Outlet temperature	°C	+26/+82	+26/+82	+26/+82	+26/+82	+26/+82	+26/+82
Min. operating pressure	bar	2,0	2,0	2,0	2,0	2,0	2,0
Max. operating pressure	bar	6,0	6,0	6,0	6,0	6,0	6,0

(1) Technical data with tolerance ±10%

(2) Reference values

(3) Volume flow sensors must be mounted on customer site

(4) Data at W40/W80

## OPERATING MAP

### Operating limits 61CG

#### High temperature - Water-source industrial heat pump

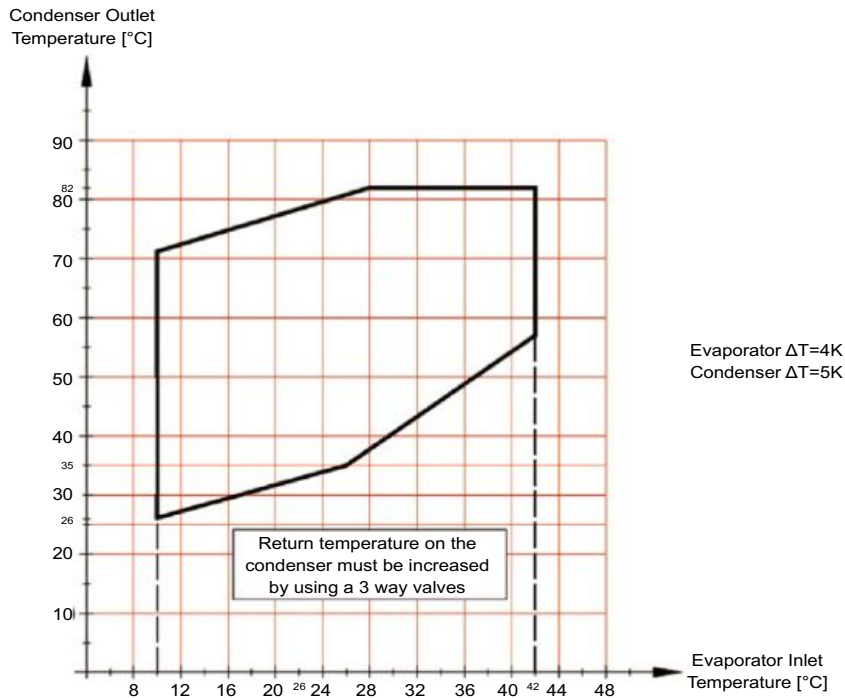

The limits of use defined in the operating map above represents the switch-off values of the heat pump. We recommend a maximum hot water set-point 2°C below the switch-off value for optimized heat pump operation.

## OPTIONS

Options	N°	Description	Advantages	AquaSnap 61CG
Gas detector (kit)	159C	Unit equipped with refrigerant leak detector. Alarms are visual and acoustic. Regular checking of the gas detector is not included in the offer.	Immediate customer notification of refrigerant losses to the atmosphere, allowing timely corrective actions.	030 - 130
Remote access	275	The touchscreen has two 10/100 Mbit Ethernet ports (RJ45) with an integral switch. Using an Ethernet patch cable, the touchscreen can be connected to the customer company network. The operator/customer must provide a secure VPN tunnel to the customer network.	Allow remote control & Check of the unit and its operating parameters from anywhere in the world and to change/optimize any settings.	030 - 130
Exchangers flexibles connection (kit)	309A	Hydraulic flexibles connexion including 90 degree connection angle.	Easy installation. Limit transmission of vibrations on the water network.	030 - 080

## DIMENSIONAL DRAWINGS

### 61CG-A030 to 0100

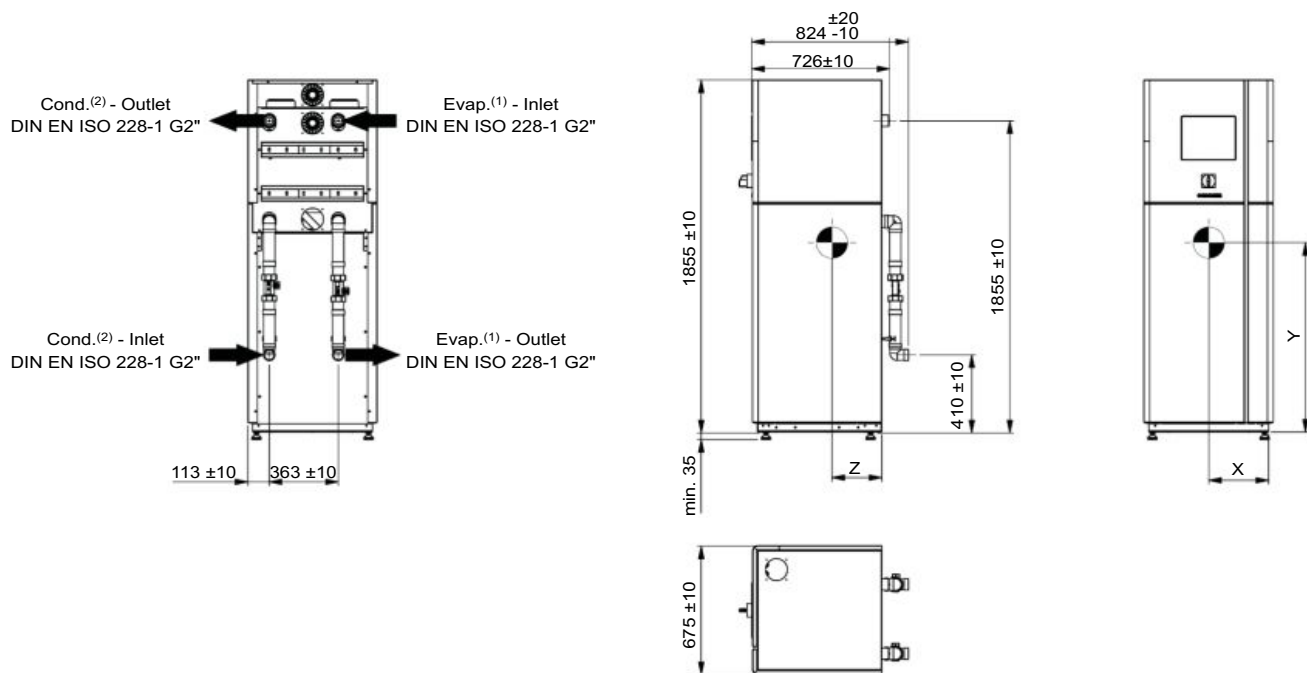

### 61CG-A130

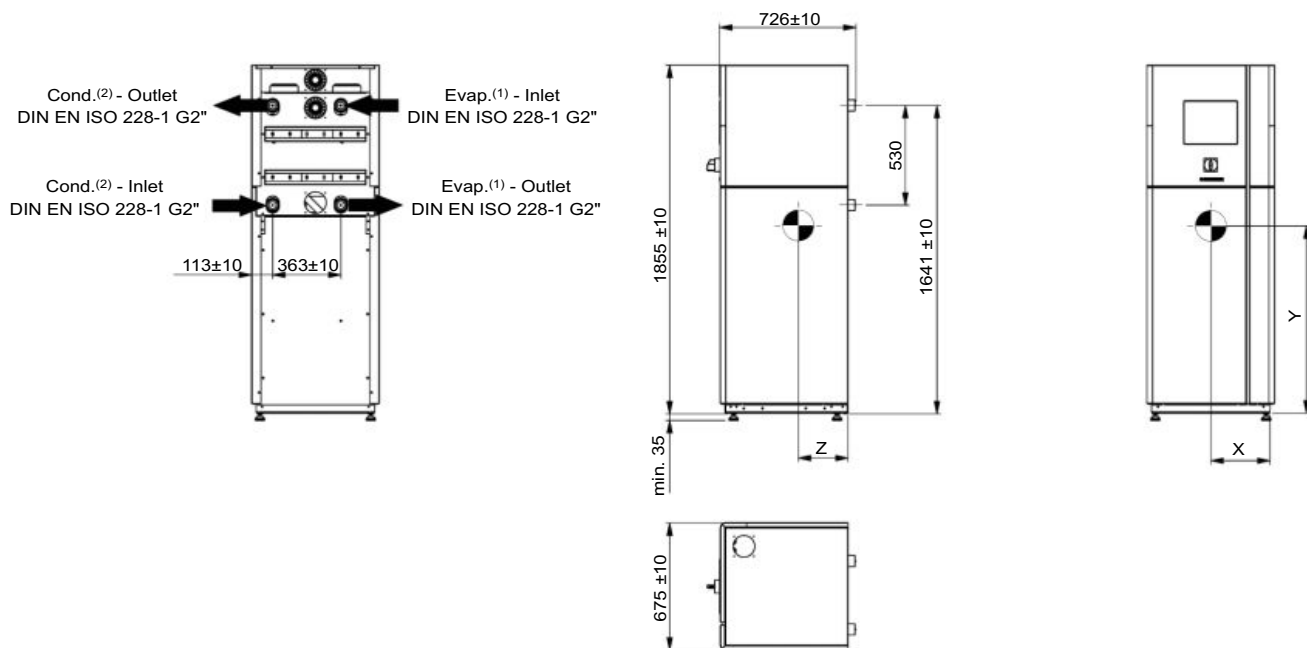

- (1) Heat source
- (2) Heat use

Type	Weight <sup>(1)</sup> (kg)	X <sup>(1)</sup> (mm)	Y <sup>(1)</sup> (mm)	Z <sup>(1)</sup> (mm)
61CG-A030	310	320	910	280
61CG-A040	510	320	840	300
61CG-A060	330	320	930	280
61CG-A080	450	320	830	290
61CG-A100	490	320	860	300
61CG-A130	510	320	840	300

(1) Reference Values

## COMPLETE CARRIER RANGES OF HIGH TEMPERATURE HEAT PUMP FOR COMMERCIAL APPLICATIONS UP TO 82°C

AquaSnap 61CG



**High temperature  
water source heat pumps**  
30 to 130 kW  
Hot water up to 82°C

AquaSnap 61WG



**High temperature  
water source heat pumps**  
20 to 190 kW  
Hot water up to 65°C

AquaSnap 61AF



**High temperature  
air source heat pumps**  
22 to 105 kW  
Hot water up to 65°C

## COMPLETE CARRIER RANGES OF HIGH TEMPERATURE INDUSTRIAL HEAT PUMP FOR DISTRICT HEATING AND PROCESS APPLICATIONS UP TO 120°C

AQUAFORCE 61CA

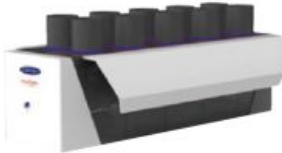

**High temperature  
air source heat pumps**  
410 kW  
Hot water up to 82°C

AQUAFORCE 61XWHZE



**High temperature  
water source heat pumps**  
300 to 1570 kW  
Hot water up to 85°C

AQUAFORCE 61CW-Z



**Very high temperature  
water source heat pumps**  
410 kW to 735 kW  
Hot water up to 92°C

AQUAFORCE 61CWD



**Ultra high temperature  
water source heat pumps**  
110 kW to 540 kW  
Hot water up to 120°C



## HEAT PUMPS WITH GREENSPEED® INTELLIGENCE



Low environmental impact

High full and part load efficiency

Compact and simple to install

Low refrigerant charge

Superior reliability

## 30RQ 040R-160R

Heating capacity 40-160 kW

Aquasnap® heat pumps and liquid chillers are the best solution for commercial and industrial applications where installers, engineering and design departments and building owners require reduced installation costs, optimal performances and maximum quality.

- AquaSnap® (30RB-30RQ) is a compact all-in-one package optimised for applications which require reduced investment and installation costs (low CapEx).
- The large options panel allows for configurations that suit user requirements.
- Optional variable-speed fans and pumps with Carrier Greenspeed® intelligence control logic make this a product which is optimised for part load applications where a high SEER, SEPR, SCOP or IPLV value is required.

In this configuration, AquaSnap® provides premium part load efficiency to reduce maintenance costs over the lifespan of the chiller. In addition, the sound levels achieved under the part load conditions are particularly low. Besides operating efficiently and quietly, the AquaSnap® range with Greenspeed® intelligence operates from -20 °C up to +46 °C as standard.



CARRIER participates in the ECP programme for LCP-HP  
Check ongoing validity of certificate:  
[www.eurovent-certification.com](http://www.eurovent-certification.com)

\* The availability of sizes and options depends on the country. Please contact your local commercial dealer for more information.

## R-32: THE BEST SOLUTION FOR SCROLL LIQUID CHILLERS AND HEAT PUMPS

Carrier was the first to introduce the R-1234ze HFO with ultra-low GWP in screw chillers, as far back as early 2016. Today, having examined its main properties, Carrier has chosen R-32 refrigerant to replace high-GWP R-410A refrigerant in its Scroll liquid chillers and heat pumps, for its lower environmental impact, high energy efficiency, good availability and ease of use.

R-32 is currently the ideal refrigeration solution for units equipped with Scroll compressors. By using R-32 refrigerants, Carrier has reduced the carbon footprint of its AquaSnap® range of liquid chillers and heat pumps by 77%. This is the result of a much lower GWP and a significant reduction in the system's cooling charge compared to the previous generation that used R-410A.

R-32 is also the right choice economically, reducing the locally imposed tax burden on HFCs based on the CO<sub>2</sub> impact.



**CO<sub>2</sub> FOOTPRINT**  
REDUCED BY UP TO **77%**

### Lower environmental impact (77% compared to R410A)

- R-32 has zero ozone depletion potential (ODP)
- The Global Warming Potential (GWP) of R-32 is 675, i.e. approximately one third of that of R-410A (PRP 2088)
- The AquaSnap® R-32 cooling charge is reduced by 30% compared to the previous version using R-410A<sup>(1)</sup>
- The carbon footprint of AquaSnap® R-32 is therefore 473 (675 x 0.7), i.e. 77% lower than the version using R-410A (2088 x 1)

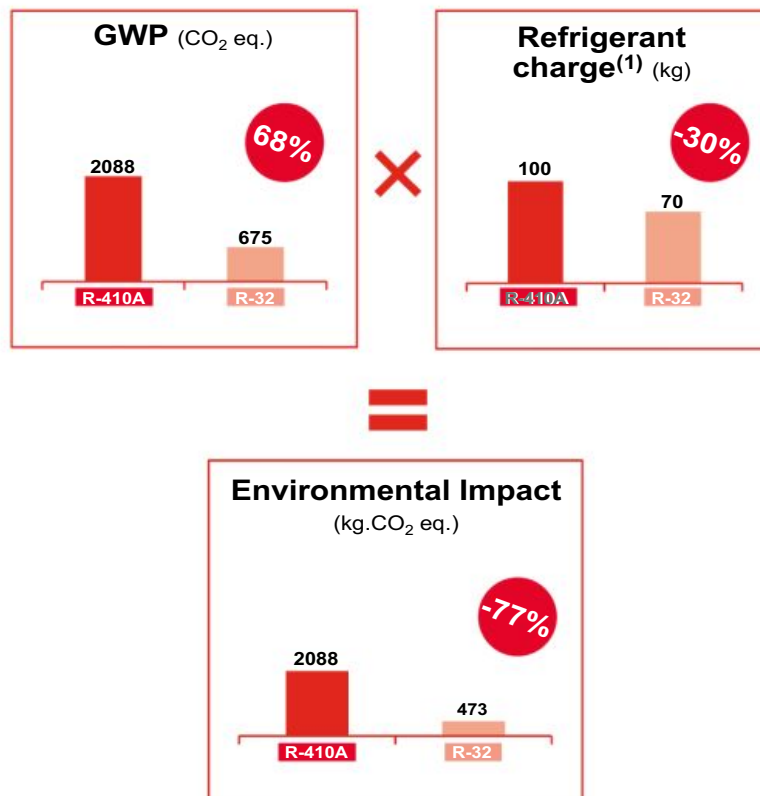

(1) Reduced refrigerant charge in Carrier heat pumps thanks to the use of R-32 and a new coil design.

## R-32: THE BEST SOLUTION FOR SCROLL LIQUID CHILLERS AND HEAT PUMPS



**SEER** up to **+8%**  
**SCOP** up to **+5%**

### High energy efficiency

The seasonal efficiency of AquaSnap® R-32 is higher than that of the previous R-410A version by:

- +8% on average in cooling mode
- +5% on average in heating mode

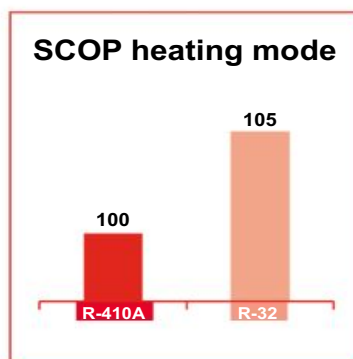
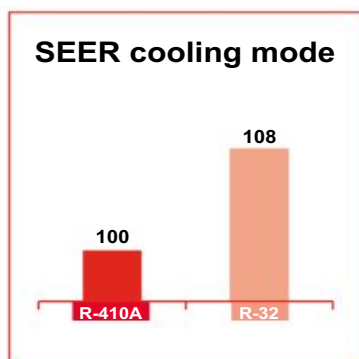

### SIMPLICITY

### Widely available and easy to use

More than 50 million R-32 air conditioning units are in circulation on the global market. While R-32 has been used for some time in residential and commercial air conditioning units, most manufacturers now use R-32 in VRF systems, liquid chillers and heat pumps, which means R-32 is widely available around the world.

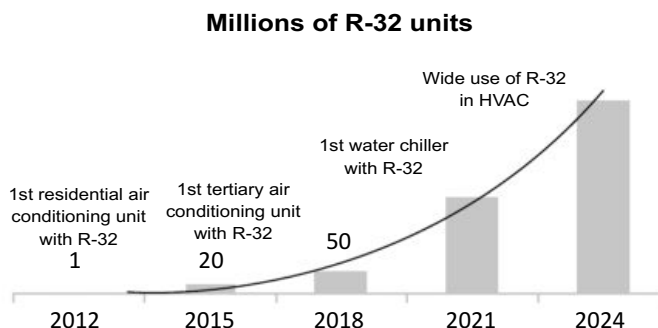

R-32 has been widely available for over 15 years, as it comprises 50% of the composition of R-410A.

R-32 is easy to use: It is a pure refrigerant, therefore it is not necessary to drain the entire circuit in the event of a leak.



### SAFETY

R-32 is an A2L classified refrigerant thanks to its low flammability.

- **No specific safety requirements** for transporting chillers by road or for outdoor installation.
- The service tools must be **certified for A2L** refrigerants in accordance with standard ISO 817 or EN378.
- Service technicians **must be qualified for brazing components** on PED 2 fluid units.

## AQUASNAP® - CUSTOMER BENEFITS

### Outstanding performance

Equipped with variable-speed fans (VSD or EC optional) and optional variable-speed pumps, Carrier's AquaSnap® 30RB/RQ range with Greenspeed® intelligence automatically adjusts the cooling capacity and water flow to perfectly adapt to the building's requirements or load variations. The result is optimum operation at both full load and part load. The 30RB/RQ offers energy efficiency up to 10% higher than the previous range with the same or a smaller footprint.

The range is already fully compliant with current Ecodesign regulations.



SEER up to 4,62  
SCOP up to 4,00

### Extensive field of application

The AquaSnap® range is suitable for a very wide range of applications from tertiary to industrial processes. The range can operate at outdoor temperatures from -20 °C to +44 °C (Optional 46 °C) and with negative water temperatures (-8 °C). From high-end office buildings and hotels to healthcare facilities, data centers and industrial projects, AquaSnap® 30RB/RQ units meets the most demanding expectations in terms of energy efficiency and savings, whatever the climate or application.

### Easy installation & maintenance

Thanks to the variable-speed pumps, automatic adjustment of the nominal water flow rate via electronic control and automatic measurement of the unit's energy performance under real conditions, pumping energy consumption is reduced by almost two thirds: These new features guarantee peace of mind for installers and maintenance companies and lower energy bills for users.



BETWEEN  
**-20 °C**  
and **46 °C**



Pumping energy  
reduced  
by up to **66%**

## AQUASNAP® - CUSTOMER BENEFITS

AquaSnap® liquid chillers and heat pumps are designed to meet current and future Ecodesign and F-Gas European regulation requirements in terms of energy efficiency and reduced CO<sub>2</sub> emissions. They use the best technologies available today:

- Reduced refrigerant charge of non-ozone depleting R-32A refrigerant with low GWP,
- Scroll compressors,
- Greenspeed® variable-speed fans option,
- NOVATION™ micro-channel heat exchangers with a new aluminium alloy (30RB),
- Brazed-plate heat exchangers with reduced pressure drops,
- Self-regulating microprocessor control with Greenspeed® intelligence,
- Colour touch screen with web connectivity options.

AquaSnap® can be equipped with a built-in hydraulic module, limiting the installation to conventional operations such as connection of the power supply and the supply and return piping (plug & play), according to the dimensions of the standard unit.

Recommended by Carrier, the AquaSnap® can be equipped with one or two Greenspeed® variable-speed pumps to significantly reduce energy costs linked to pumping (reduction of more than two-thirds), ensure optimum water flow rate control, and improve overall system reliability.



### Very economical operation

- High unit full- and part-load energy efficiency and efficient design of the water side:
  - SEER<sub>12/7 °C</sub> up to 4.6 in line with the new Ecodesign 2016/2281 regulation.
  - SCOP<sub>35 °C</sub> up to 3.84
  - Multiple scroll compressors equipped with a high-efficiency motor which can exactly match the cooling capacity to the load required
  - Electronic expansion valve enabling operation at a lower condensing pressure and improved use of the evaporator heat transfer area (superheat control)
  - Condenser with high-efficiency NOVATION™ (30RB) aluminium micro-channel heat exchangers and Greenspeed® variable-speed fans (optional)
  - Low pressure drop brazed plate heat exchangers (< 45 kPa under Eurovent conditions).
- Specific control functions to reduce unit cooling energy use during occupied and unoccupied periods:
  - Internal timer: Switches the chiller on/off and controls operation at a second setpoint,
  - Setpoint automatically offset based on the outdoor air temperature or room air temperature (via an option),
  - Floating high pressure (HP) management,
  - Variable-speed fan control,
  - Cooling demand limitation.

Refer to the control chapter for more information.

- Greenspeed® variable-speed pump to reduce pumping energy consumption by up to two-thirds (option recommended by Carrier):
  - Eliminate energy losses through the water flow rate control valve by electronically setting the nominal water flow rate,
  - Save energy during stand-by periods or part-load operation by automatically reducing the water pump speed. The energy consumption of the pump motor varies according to the cube of the speed, so that a reduction in speed of just 40% can reduce energy consumption by 80%,
  - Improved unit part-load performance (increased SEER/SCOP value with variable water flow according to standard EN14825).

Refer to the hydraulic option chapter for more information.

- Extra energy savings through multiple options:
  - Carrier dry cooler Free cooling mode management,
  - Partial heat recovery.
- Reduced maintenance costs:
  - Fast diagnosis of possible incidents and their history via the control,
  - Programmable maintenance alert,
  - Programmable F-Gas leak monitoring alert



## AQUASNAP® - CUSTOMER BENEFITS

### Low noise level

- Condenser with fixed-speed fans (30RB-30RQ):
  - Optional low-speed and variable-speed fans (700 rpm) and compressor enclosure to reduce full-load noise level by up to -9 dB(A)
  - Low noise 6th generation Flying bird™ fans, made of a composite material (Carrier patent)
  - Rigid fan installation for reduced noise (Carrier patent).
- Condenser with Greenspeed® variable-speed fans (optional) recommended by Carrier for even quieter operation:
  - Optional factory setting of the fan at low speed, with compressor enclosure to reduce full-load noise level by up to -9 dB(A),
  - Exceptional acoustic signature during part-load operation through smooth fan speed variation.
- Specific control functions or features to reduce noise level during the night or unoccupied periods:
  - Night-time sound control with cooling capacity and fan speed limitation,
  - Low-noise scroll compressors with low vibration level,
  - The compressor assembly is installed on an independent chassis and supported by flexible anti-vibration mountings,
  - Dynamic suction and discharge piping support, minimising vibration transmission (Carrier patent),
  - Acoustic compressor enclosure, reducing radiated noise emissions (optional).

### Quick and easy installation

- Compact design:
  - AquaSnap® units are designed with compact dimensions for easy installation.
  - With a length of approximately 4.8 m for 550 kW and a width of 2.25 m, the units require minimal floor space.
- Integrated hydraulic module (option):
  - Low- or high-pressure water pump (as required),
  - Single or dual pump (as required) with runtime balancing and automatic changeover to the back-up pump if a fault develops
  - Built-in variable-speed pumps with automatic nominal water flow adjustment via electronic control on the user display.
  - Water filter protects the water pump against circulating debris,
  - Pressure sensors for direct numerical display of the water flow rate and water pressures,
  - Thermal insulation and frost protection down to -20 °C, using a heater (option),
  - High-capacity membrane expansion tank (option).
- Built-in hydraulic module with Greenspeed® variable-speed pump (option recommended by Carrier):
  - Quick and easy electronic setting of the nominal water flow rate when the unit is commissioned, thus eliminating the need to adjust the water flow rate control valve,
  - Automatic control of the pump speed based on constant speed, constant pressure difference or constant temperature difference.

- Simplified electrical connections
  - A single power supply point without neutral,
  - Main disconnect switch with high trip capacity,
  - 24 V control circuit using an integrated transformer.
- Simplified hydraulic connections:
  - Victaulic type couplings on the exchanger;
  - Clearly identified and practical reference marks for entering and leaving water connections;
- Fast unit commissioning
  - Systematic factory test before shipment,
  - Quick-test function for step-by-step verification of the sensors, electrical components and motors.

### Reduced installation costs

- Optional Greenspeed® variable-speed pump with hydraulic module (option recommended by Carrier)
  - Cut costs relating to the water flow control valve,
  - The design of the water system with variable primary flow (VPF) can provide significant installation cost savings compared with traditional constant primary systems with variable secondary circuits; elimination of the secondary distribution pump, etc.
  - Water system design with fan coils fitted with 2-way valves instead of 3-way valves.
- No buffer tank required thanks to Carrier's advanced control algorithm
  - Minimum water loop volume reduced to 2.5 l/kW.

## AQUASNAP® - CUSTOMER BENEFITS

### Environmentally responsible

AquaSnap® liquid chillers with Greenspeed® intelligence (With optional variable-speed fans and pumps) are a boost for green cities and contribute to a sustainable future. Combining a refrigerant charge up to 30% lower, with R-32 refrigerant with a GWP 70% lower than that of the previous version using R410A, and exceptional energy efficiency, this chiller significantly reduces energy consumption while reducing carbon dioxide emissions throughout its life cycle.

- Pumping energy consumption can be reduced by up to 2/3 using Greenspeed® variable-speed pumps,
- 40% lower refrigerant charge: The micro-channel technology used for condenser coils optimises heat transfer while minimising the refrigerant volume.
- Sealed refrigerant circuits:
  - Leaks are eliminated thanks to the absence of capillary tubes and the use of flare connections,
  - Verification of pressure transducers and temperature sensors without transferring refrigerant charge,
  - Discharge line shut-off valve and liquid line service valve for simplified maintenance,
  - Qualified Carrier maintenance personnel to provide refrigerant servicing,
  - ISO 14001 production plant.

### Superior reliability

- State-of-the-art concept
  - Two self-contained refrigerant circuits; the second one automatically takes over if the first one develops a fault, maintaining partial cooling in all circumstances,
  - All compressor components are easily accessible on site, minimising downtime,
  - All-aluminium NOVATION™ micro-channel heat exchanger (MCHE) (30RB) with higher corrosion resistance than a conventional coil. The all-aluminium construction eliminates the formation of galvanic currents between aluminium and copper which can corrode the coil in saline or corrosive atmospheres,
  - V-coil design to protect the coils against hail impact,
  - Optional Enviro-shield® anti-corrosion coil coating for use in moderately corrosive environments. Coating applied through conversion process which modifies the surface of the aluminium producing a coating that is integral to the coil. Immersion in a bath to ensure 100% coverage. No heat transfer variation, tested for 4000 hours in salt spray per ASTM B117,
  - Optional Super Enviro-shield® anti-corrosion coil coating for use in extremely corrosive environments. Extremely durable and flexible epoxy polymer coating applied on micro-channel heat exchangers by electro coating process with a final UV protective topcoat. Minimal heat transfer variation, tested for 6000 hours in salt spray per ASTM B117, superior impact resistance per ASTM D2794
  - Electronic flow switch. Auto-setting according to cooler size and fluid type.

- Self-regulating control
  - The control algorithm prevents excessive compressor cycling and reduces the quantity of water in the water loop (Carrier patent),
  - Automatic compressor unloading in case of abnormally high condensing pressure,
  - Automatic fan speed adjustment in case of coil fouling (30RB models),
  - Smooth fan start to increase unit lifetime (optionals include variable-speed fans).
- Exceptional endurance tests:
  - To design critical components and sub-assemblies to minimise the risk of failure on site, Carrier uses specialised laboratories and advanced dynamic simulation tools.
  - To ensure that the units reach customer sites in the same condition as they are when tested in the factory, Carrier tests the machine behaviour during transportation over 250 km. The road test is based on a military standard and is the equivalent to 5000 km by truck on a normal road.
  - To guarantee the coil corrosion resistance, salt spray corrosion resistance tests are performed in the group's laboratory.
  - In addition, to maintain the unit's performance throughout its operating life whilst minimising maintenance costs, end users can access the "Connected Services" remote monitoring service.

### Designed to support Green Building Design

A green building is a building that is environmentally sustainable and is designed, constructed and operated to minimise the total impact on the environment.

The resulting building will be economical to operate, offer increased comfort and create a healthier environment for the people who live and work there, increasing productivity.

The air conditioning system can use between 30 and 40% of the annual building energy consumption. Choosing the right air conditioning system is one of the main considerations when designing a green building. For buildings with a load that varies throughout the year, the AquaSnap® 30RB/30RQ unit offers a solution to this important challenge.

A number of green building certification programmes exist in the market and offer third-party assessment of green building measures for a wide variety of building types.

The following example looks at how Carrier's new AquaSnap® range helps customers affected by LEED® building certification.

## AQUASNAP® - CUSTOMER BENEFITS

### Energy saving certificate

The AquaSnap® 30RB/RQ unit is eligible for energy saving certificates in France (CEE) in comfort, industrial and agriculture applications:

- Floating High pressure control (by modulating the air flow through fan activation and speed)
- Floating Low pressure control
- Variable speed on asynchronous fan motor (optional)
- Variable speed on asynchronous pump motor (optional)
- Partial heat recovery (option)

For more details about financial incentives in France, please refer to the "CEE product sheet".

### The AquaSnap® range and LEED® certification

The LEED® (Leadership in Energy and Environmental Design) green building certification programme is a major initiative set up to assess the design, construction and operation of green buildings with points assigned in seven credit categories:

- Sustainable Sites (SS),
- Water efficiency (WE),
- Energy and atmosphere (EA),
- Materials and resources (MR),
- Indoor environmental quality (IEQ),
- Innovation in design (ID),
- Regional Priority (RP).

There are a number of different LEED® products.

While the strategies and categories assessed remain the same, the distribution of points varies depending on the type of building and the requirements of the application, based on whether it is a new construction, school, core & shell, retail or healthcare.

All programmes now use the same point scale:

#### 110 LEED® points available

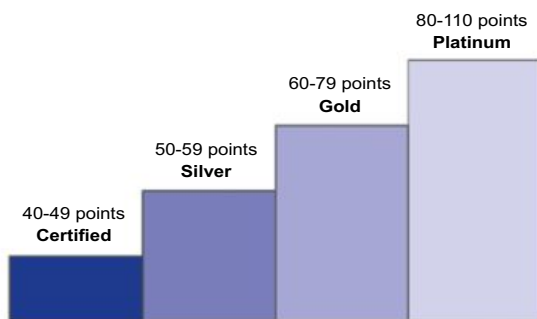

The majority of credits in LEED® rating systems are performance-based and achieving them is dependent on the impact of each component or sub-system on the building as a whole.

While the LEED® green building certification programmes do not certify products or services, choosing the right products, systems or service programmes is critical to obtaining LEED® certification for a registered project, because the right products or service programmes can help meet the goals of green construction and ongoing operation and maintenance.

The choice of heating, ventilation and air conditioning (HVAC) products in particular can have a significant impact on LEED® certification, as the HVAC system directly impacts two categories that together influence 40% of the available points.

### EcoPassport®

The PEP ecopassport® programme provides an international reference framework for procedures enabling manufacturers to report the environmental specifications of their products in the form of an environmental claim known as a Product Environmental Profile (PEP).

The PEP ecopassport® programme guarantees that PEPs are correctly drawn up, verified and reported in line with the requirements of the ISO 14025 and IEC/PAS 62545 standards.

The Life Cycle Analysis (LCA) PEP is the environmental identity card for an item of equipment which details the environmental impacts of the product during its life cycle according to eight mandatory indicators:

1. Global Warming Potential,
2. Impact on the ozone layer,
3. Acidification of soil and water,
4. Eutrophication of water,
5. Photochemical ozone creation,
6. Abiotic resource depletion,
7. Fresh water consumption,
8. Total use of primary energy during the life cycle.

Products with certified environmental profiles are used to support methods to assess building sustainability such as BREEAM, LEED. BREEAM, LEED gives additional recognition for materials with robust environmental product declaration types using manufacturer data.

Carrier is the first HVAC manufacturer to provide PEPs for liquid chillers and heat pumps with, not only the 8 mandatory indicators, but all 27 indicators.

The AquaSnap® PEP can be downloaded from the PEP ecopassport® website: <http://www.pep-ecopassport.org/fr/>

## AQUASNAP® - CUSTOMER BENEFITS

### Designed to support Green Building Design

#### Overview of LEED® for new construction and major renovations

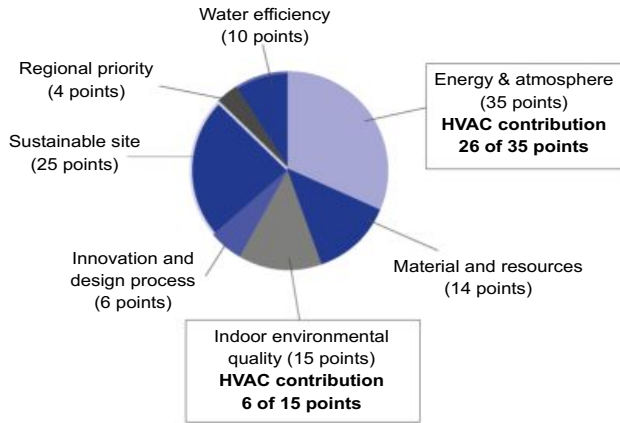

The new AquaSnap® units from Carrier can help building owners to earn LEED® points in particular in the Energy & Atmosphere (EA) credit category and help address the following prerequisites and credit requirements:

- EA prerequisite 2: Minimum energy performance
- 30RB/RQ units exceed the energy efficiency requirements of ASHRAE 90.1-2007; therefore they satisfy the prerequisites.
- EA prerequisite 3: Fundamental refrigerant management  
30RB/RQ units do not use chlorofluorocarbon (CFC) refrigerants, thus satisfying the prerequisites.
- EA credit 1: Optimise energy performance (1 to 19 points)  
Points for this credit are assigned depending on the energy cost reduction virtually achievable by the new building, compared to ASHRAE 90.1-2007 reference. 30RB/RQ units, which are designed for high performance especially during part load operation, help to reduce the building's energy consumption and therefore to gain points for this credit. In addition, the Carrier HAP (Hourly Analyses Program) can be used to analyse energy. It meets the modelling requirements for this credit and produces reports which can be easily transferred to LEED® charts.
- EA credit 4: Enhanced refrigerant management (2 points)  
With this credit, LEED® awards systems that minimise the installed system's Ozone Depletion Potential (ODP) and Global Warming Potential (GWP). 30RB/30RQ units use a reduced R-32 charge and therefore help satisfy the requirements of this LEED® credit.

**NOTE:** This section describes the prerequisites and credit requirements in LEED® for New Construction and is directly related to the 30RB/30RQ units. Other prerequisites and credit requirements are not directly and purely related to the air-conditioning unit itself, but more to the control of the HVAC system as a whole.

i-Vu®, Carrier's open control system, has features that can be valuable for:

- EA prerequisite 1: fundamental commissioning of energy management systems;
- EA credit 3: enhanced commissioning (2 points);
- EA credit 5: measurements and verification (3 points).

**NOTE:** Products are not reviewed or certified under LEED®. LEED® credit requirements cover the performance of materials in aggregate, not the performance of individual products or brands. For more information on LEED®, visit [www.usgbc.org](http://www.usgbc.org).

## 30RB - 30RQ TECHNICAL OVERVIEW



### SIXTH GENERATION FLYING BIRD™ FIXED-SPEED FANS

- Exclusive Carrier design
- Fan blade design inspired by nature
- High efficiency version with AC motor technology
- Variable speed option:
  - Patented algorithm to control the fan speed.
  - Dedicated variator or EC type motor.
  - Night mode operation.



### NOVATION™ SECOND GENERATION MICRO CHANNEL HEAT EXCHANGERS (30RB)

- Increased reliability with new aluminium alloy
- Significantly reduces the refrigerant charge (-40% compared to Cu/Al coils)
- Improved thermal performance, improved efficiency and lower pressure drops compared to Cu/Al coils
- Enviro-Shield® coating for mildly corrosive environments
- Super Enviro-Shield® coating for highly corrosive environments (industrial or marine applications)
- Easy cleaning with high pressure air or water washer



### SmartVu™ CONTROL

- 6 languages available
- 4.3" user-friendly touch screen
- All main parameters displayed on one screen
- Direct access to the unit's technical drawings and the main service documents
- Very easy online monitoring
- Easy and secure access to unit parameters
- Optional Bacnet, J-Bus or LON communication interfaces



### SCROLL COMPRESSORS



### REDUCED REFRIGERANT CHARGE



### HIGH-EFFICIENCY BRAZED PLATE HEAT EXCHANGER

- Latest generation asymmetrical type (unit with 2 circuits)
- Low pressure drop



### VARIABLE-SPEED PUMP

- Water flow electronic control and reading
- Automatic protection of the pump against low pressure
- Multiple control options:
  - Constant flow with low speed mode on standby
  - Variable flow based on pressure difference or constant temperature

### PUMP SPEED REGULATOR





## TECHNICAL INSIGHTS

### SmartVu™ control

The SmartVu™ control combines intelligence with operating simplicity. The control constantly monitors all machine parameters and precisely manages the operation of compressors, expansion devices, fans and the evaporator water pump for optimum energy efficiency.

The SmartVu™ control features advanced communication technology over Ethernet (IP) and a user-friendly and intuitive user interface with 4.3 inch colour touch screen.

- Energy management configuration
  - Internal timer: Controls chiller on/off times and operation at a second setpoint,
  - Setpoint offset based on the outdoor air temperature,
  - Master/slave control of two chillers operating in parallel with runtime balancing and automatic changeover in case of a unit fault,
  - For further energy savings, the AquaSnap® can be monitored remotely by Carrier experts for energy consumption diagnosis and optimisation.
- Integrated features
  - Night mode: Capacity and fan speed limitation for reduced noise level,
  - With hydraulic module: Water pressure display and water flow rate calculation.
- Advanced communication features
  - Easy, high-speed communication technology over Ethernet (IP) to a centralised building management system,
  - Access to multiple unit parameters.
- Maintenance functions
  - F-Gas regulation leak check reminder alert,
  - Maintenance alert can be configured to days, months or hours of operation,
  - Storage of maintenance manual, wiring diagram and spare parts list,
  - Display of trend curves for the main values,
  - Management of a fault memory allowing a log of the last 50 incidents to be accessed, with operating readings taken when the fault occurs,
  - Blackbox memory.

### ■ 4.3" SmartVu™ user interface



- Intuitive and user-friendly 4.3" inch touch screen interface,
- Concise and clear information is available in local languages,
- Complete menu, customised for different users (end user, service personnel or Carrier engineers).

### Remote management (standard)

Units with SmartVu™ control can be easily accessed from the internet, using a PC with an Ethernet connection. This makes remote control quick and easy and offers significant advantages for service operations.

The AquaSnap® is equipped with an RS485 serial port that offers multiple remote control, monitoring and diagnostic possibilities. Carrier offers a vast choice of control products, specially designed to control, manage and supervise the operation of an air conditioning system. Please consult your Carrier representative for more information.

The AquaSnap® also communicates with other centralised building management systems via optional communication gateways.

A connection terminal allows the AquaSnap® unit to be remotely controlled by wire:

- Start/stop: Opening of this contact will shut down the unit,
- Dual setpoint: closing of this contact activates a second setpoint (e.g.: unoccupied mode),
- Demand limit: Closing of this contact limits the maximum chiller capacity to a predefined value,
- Operation indication: This volt-free contact indicates that the chiller is operating (cooling load),
- Alarm indication: this volt-free contact indicates the presence of a major fault that has led to the shut-down of one or several refrigerant circuits,
- Setpoint adjustable via 4-20 mA signal.

## OPTIONS

Options	No.	Description	Advantages	AquaSnap 30RB	Aquasnap 30RQ
Corrosion protection, traditional coils	3A	Fins made of pre-treated aluminium (polyurethane and epoxy)	Improved corrosion resistance, recommended for moderate marine and urban environments	-	040-160
Low-temperature brine solution	6B	Low temperature chilled water production down to -8 °C with ethylene glycol and propylene glycol.	Covers specific applications such as ice storage and industrial processes	040-160	040-160
High static fans	12	Unit equipped with high-pressure static variable-speed fans (maximum 200 Pa), each fan being equipped with a connection flange for connection to the ducting system.	Ducted fan discharge, optimised temperature control, based on the operating conditions and system characteristics	040-160	040-160
Return air connection frame	12A	Unit equipped with a connection frame at the heat exchange coil inlet	Facilitates channelling of the air at the unit inlet.	040-080	040-080
Very low noise level	15LS	Acoustic compressor enclosure and low-speed fans	Noise level reduction for sensitive sites	040-160	040-160
High ambient temperature	16	Unit equipped with a higher speed fan	Unit operating range extended to higher ambient temperatures	040-160	040-160
EC fans	17	Unit equipped with EC fans	Improves the unit's energy efficiency	040-160	040-160
Protection grilles	23	Metallic protection grilles	Coil protection against possible impact	040-160	040-160
Air filter and return air connection frame	23B	Unit equipped with a connection frame at the heat exchange coil inlet and washable G2 efficiency filter in accordance with EN 779	Facilitates channelling of the air at the unit inlet and protects the air exchanger against pollution	040-080	040-080
Soft starter per compressor	25	Electronic starter on each compressor	Reduced start-up current	040-160	040-160
Winter operation down to -20 °C	28	Fan speed control via frequency converter	Stable unit operation when the outdoor air temperature is between -10 °C and -20 °C	040-160	040-160
Water exchanger frost protection	41	Electric heater on the water type heat exchanger and the water duct	Water type heat exchanger module frost protection for an outdoor air temperature between 0 °C and -20 °C	040-160	040-160
Hydronic module antifreeze protection	42	Electric heater on the hydronic module	Antifreeze protection of the hydronic module for outdoor temperatures down to -20 °C	040-160	040-160
Exchanger and hydronic module antifreeze protection	42B	Electric heaters on the water heat exchanger, water pipes, hydronic module, optional expansion tank and buffer tank	Water type heat exchanger and hydronic module frost protection down to an outdoor air temperature of -20 °C	040-160	040-160
Partial heat recovery	49	Unit equipped with one desuperheater on each refrigerant circuit	Simultaneous production of free high-temperature hot water and chilled water production (or hot water for the heat pump)	040-160	040-160
Master/slave operation	58	Unit equipped with supplementary water outlet temperature sensor kit (to be field installed) allowing master/slave operation of two units connected in parallel	Optimised operation of two units connected in parallel operation with runtime balancing	040-160	040-160
Evaporator single HP pump	116R	High-pressure fixed-speed water pump, drain valve, air vent and pressure sensors. (optional expansion vessel and built-in safety hydraulic components available)	Quick and easy installation (plug & play)	040-160	040-160
Evaporator dual HP pump	116S	Dual high-pressure fixed-speed water pump, electronic water flow control, pressure sensors. (optional expansion tank and built-in hydraulic safety components available)	Quick and easy installation (plug & play)	040-160	040-160
Variable-speed single HP pump	116V	Single low-pressure water pump, water filter, electronic water flow control, pressure sensors. Multiple variable water flow control options (optional expansion tank and built-in hydraulic safety components available)	Quick and easy installation (plug & play), significant pumping energy cost savings (up to 2/3), tighter water flow control.	040-160	040-160
Variable-speed dual high-pressure pump	116W	Dual high-pressure water pump with speed regulator, pressure sensors. Multiple water flow rate control options. For more details, refer to the dedicated chapter.	Quick and easy installation (plug & play), significant pumping energy cost savings (more than two-thirds), tighter water flow control, improved system reliability	040-160	040-160
Variable-speed single LP pump	116X	Single low-pressure water pump with speed regulator, pressure sensors. Multiple water flow rate control options. (optional expansion vessel and built-in hydraulic safety components available)	Quick and easy installation (plug & play), significant pumping energy cost savings (up to 2/3), tighter water flow control.	040-160	040-160

## OPTIONS

Options	No.	Description	Advantages	AquaSnap 30RB	Aquasnap 30RQ
Variable-speed dual LP pump	116Y	Evaporator hydronic module equipped with a variable-speed low-pressure pump, a drain valve, an air vent and pressure sensors. For more details, refer to the dedicated chapter (expansion tank not included; option with built-in hydraulic safety components available)	Quick and easy installation (plug & play), significant pumping energy cost savings (more than two-thirds), tighter water flow control, improved system reliability	040-160	040-160
Evaporator single LP pump	116T	Single low-pressure fixed-speed water pump, electronic water flow control, pressure sensors. (optional expansion tank and built-in hydraulic safety components available)	Quick and easy installation (plug & play)	040-160	040-160
LP dual-pump hydronic module	116U	Dual low pressure water pump, water filter, electronic water flow control, pressure sensors. For more details, refer to the dedicated chapter (expansion tank not included; option with built-in hydraulic safety components)	Quick and easy installation (plug & play)	040-160	040-160
Heating Optimized	119D	Specific configuration to optimized heating mode	Enlarge operating map in heating mode , and increase energetics performances (COP/SCOP)	-	040-160
Lon gateway	148D	Two-directional communication board complying with Lon Talk protocol	Connects the unit by communication bus to a building management system	040-160	040-160
Bacnet over IP	149	Two-directional high-speed communication using BACnet protocol over Ethernet network (IP)	Easy and high-speed connection by Ethernet line to a BMS. Allows access to multiple unit parameters	040-160	040-160
ModBus over IP and RS485 communication gateway	149B	Two-directional high-speed communication using the ModBus over Ethernet network (IP) protocol	Easy, quick connection via Ethernet line to a building technical management system. Allows access to several unit parameters.	040-160	040-160
External boiler management	156A	Control board factory-installed on the unit to control a boiler	Extended remote control capabilities to a boiler on/off command. Permits easy control of a basic heating system	-	040-160
Electric heaters management	156B	Control board factory-installed on the unit with additional inputs/outputs in order to manage up to 4 external heating stages (electrical heaters...)	Extended remote control capabilities to up to 4 electric heaters. Permits easy control of a basic heating system	-	040-160
Input contact for Refrigerant leak detection	159	0-10 V signal to report any refrigerant leakage in the unit directly on the controller (the leak detector itself must be supplied by the customer)	Immediate customer notification of refrigerant losses to the atmosphere, allowing timely corrective actions	040-160	040-160
Refrigerant leak detector	159C	Unit equipped with refrigerant leak detector	Immediate customer notification of refrigerant losses to the atmosphere, allowing timely corrective actions	040-160	040-160
Compliance with Russian regulations	199	EAC certification	Compliance with Russian regulations	040-160	040-160
Insulation of the evaporator inlet/outlet refrigerant lines	256	Thermal insulation of the evaporator inlet/outlet refrigerant lines, with flexible and UV-resistant insulation	Prevents condensation on the evaporator inlet/outlet refrigerant lines	040-160	040-160
Enviro-Shield anti-corrosion protection	262	Coating applied using a conversion process which modifies the surface of the aluminium producing a coating that is integral to the coil. Complete immersion in a bath to ensure 100% coverage. Minimal heat transfer variation, tested to withstand more than 4000 hours of salt spray as per ASTM B117	Improved corrosion resistance, recommended for use in moderately corrosive environments	040-160	-
Super Enviro-Shield anti-corrosion protection	263	Extremely durable and flexible epoxy polymer coating applied by electro coating process, final UV protective topcoat. Minimal heat transfer variation, tested to withstand 6000 hours of constant neutral salt spray as per ASTM B117, improved impact resistance as per ASTM D2794	Improved corrosion resistance, recommended for use in extremely corrosive environments	040-160	-
Evaporator screw connection sleeves kit	264	Evaporator inlet/outlet screw connection sleeves	Allows unit connection to a screw connector	040-160	040-160
Evaporator sleeve kit (to be welded)	266	Victaulic piping connections with welded joints	Easy installation	040-160	040-160

## OPTIONS

Options	No.	Description	Advantages	AquaSnap 30RB	Aquasnap 30RQ
Reinforced ECM filtration for fan VFD	282A	Fan variable frequency drive compliant with IEC 61800-3 class C1	Allows unit installation in domestic residential environment by reducing electromagnetic interferences	040-160	040-160
Reinforced ECM filtration for pump VFD	282B	Pump variable frequency drive compliant with IEC 61800-3 class C1	Allows unit installation in domestic residential environment by reducing electromagnetic interferences	040-160	040-160
Expansion tank	293	6-bar expansion tank integrated in the hydraulic module (requires hydraulic module option)	Easy and fast installation (plug & play), and protection of closed water systems from excessive pressure	040-160	040-160
Water buffer tank module	307	Built-in water buffer tank module	Avoid short cycle on compressors and ensure a stable water in the loop	040-160	040-160
Free cooling mode dry cooler management	313	Control and connections to a free cooling dry cooler 09PE or 09VE fitted with option FC control box	Easy system management, control capacity extended to a dry cooler used in free cooling mode	040-160	-
Compliance with UAE regulations	318	Additional label on the unit with rated power input, rated current and EER in accordance with AHRI 550/590	Compliance with ESMA standard UAE 5010-5:2016.	040-160	-
Compliance with Qatar regulations	319	Specific name plate on the unit with 415 V +/-6% power supply	Compliance with KAHRAMAA regulations in Qatar	040-160	-
Installation or application process outside Europe	326	Specific management of option compatibility	Permits non-standard option compatibility for HVAC application in the EU	040-160	040-160
Compliance with Moroccan regulations	327	Specific regulatory documentation	Compliance with Moroccan regulations	040-160	040-160
Delivery with plastic tarp cover	331	Unit wrapped in a plastic cover and strapped onto a wooden pallet.	Protects against dust and external soiling of the unit during storage and transport.	040-160	040-160

## PHYSICAL DATA, SIZES 040R TO 160R

30RB			040R	045R	050R	055R	060R	070R	080R	090R	100R	120R	140R	160R	
<b>Standard unit</b>															
<b>Cooling Full load performances*</b>	CA1	Nominal capacity	kW	41,7	47,3	52,9	56,1	63,6	71,2	81,1	93,4	107	124	140	160
		EER	kW/kW	2,95	2,94	2,93	2,97	2,89	2,90	2,78	2,97	2,83	2,85	2,87	2,76
	CA2	Nominal capacity	kW	54,6	62,7	69,4	74,3	84,6	93,0	103	126	142	162	183	203
		EER	kW/kW	3,60	3,60	3,51	3,61	3,63	3,49	3,22	3,72	3,48	3,40	3,48	3,21
Seasonal energy efficiency**		<b>SEER<sub>12/7 °C</sub> Comfort low temp.</b>	<b>kWh/kWh</b>	<b>4,41</b>	<b>4,47</b>	<b>4,50</b>	<b>4,62</b>	<b>4,41</b>	<b>4,31</b>	<b>4,24</b>	<b>4,38</b>	<b>4,51</b>	<b>4,57</b>	<b>4,46</b>	<b>4,37</b>
		$\eta_{s\ cool\ 12/7 °C}$	%	173	176	177	182	174	169	167	172	177	180	176	172
		<b>SEER<sub>23/18 °C</sub> Comfort medium temp.</b>	<b>kWh/kWh</b>	<b>6,10</b>	<b>6,11</b>	<b>6,06</b>	<b>6,17</b>	<b>5,61</b>	<b>5,72</b>	<b>5,46</b>	<b>5,54</b>	<b>5,78</b>	<b>5,73</b>	<b>5,61</b>	<b>5,34</b>
		<b>SEPR<sub>12/7 °C</sub> Process high temp.</b>	<b>kWh/kWh</b>	<b>6,30</b>	<b>6,23</b>	<b>6,23</b>	<b>6,21</b>	<b>5,92</b>	<b>5,46</b>	<b>5,21</b>	<b>5,45</b>	<b>5,19</b>	<b>5,24</b>	<b>5,37</b>	<b>5,15</b>
		<b>SEPR<sub>-2/-8 °C</sub> Process medium temp.</b>	<b>kWh/kWh</b>	<b>3,59</b>	<b>3,65</b>	<b>3,79</b>	<b>3,89</b>	<b>3,65</b>	<b>3,61</b>	<b>3,67</b>	<b>3,54</b>	<b>3,54</b>	<b>3,74</b>	<b>3,61</b>	<b>3,68</b>
Part Load integrated values	IPLV.SI	kW/kW	4,945	5,025	5,182	5,270	5,369	4,630	4,630	4,904	4,953	4,997	4,707	4,680	
<b>Sound levels</b>															
<b>Standard unit</b>															
Sound power <sup>(1)</sup>		dB(A)	81,5	82,0	83,5	83,5	89,0	89,0	89,0	91,5	91,5	92,0	92,0	92,0	
Sound pressure at 10 m <sup>(2)</sup>		dB(A)	50,0	50,5	52,0	52,0	57,0	57,5	57,0	60,0	59,5	60,0	60,0	60,0	
<b>Unit + option 15LS</b>															
Sound power <sup>(1)</sup>		dB(A)	78,5	79,0	80,0	80,0	80,0	80,0	80,0	83,0	83,0	83,0	83,0	83,0	
Sound pressure at 10 m <sup>(2)</sup>		dB(A)	47,0	47,5	48,5	48,5	48,0	48,5	48,0	51,0	51,0	51,5	51,0	51,0	
<b>Dimensions</b>															
<b>Standard unit</b>															
Length		mm	2109	2109	2109	2109	2109	2109	2109	2275	2275	2275	2275	2275	
Width		mm	1090	1090	1090	1090	1090	1090	1090	2125	2125	2125	2125	2125	
Height		mm	1330	1330	1330	1330	1330	1330	1330	1330	1330	1330	1330	1330	
Unit height (option 12)		mm	1372	1372	1372	1372	1372	1372	1372	1372	1372	1372	1372	1372	
Unit height (option 307)		mm	1931	1931	1931	1931	1931	1931	1931	1931	1931	1931	1931	1931	
Unit height (option 12 + 307)		mm	1973	1973	1973	1973	1973	1973	1973	1973	1973	1973	1973	1973	

\* In accordance with standard EN14511-3:2022.

\*\* In accordance with EN14825:2022, average climatic conditions.

CA1 Cooling mode conditions: evaporator water inlet/outlet temperature 12 °C/7 °C, outdoor air temperature 35 °C, evaporator fouling factor 0 m<sup>2</sup>. k/W

CA2 Cooling mode conditions: evaporator water inlet/outlet temperature 23 °C/18 °C, outdoor air temperature 35 °C, evaporator fouling factor 0 m<sup>2</sup>. k/W

$\eta_{s\ cool\ 12/7 °C}$  & SEER<sub>12/7 °C</sub> **Values in bold comply with Ecodesign Regulation (EU) No. 2016/2281 for Comfort applications**

SEER<sub>23/18 °C</sub> **Values in bold comply with Ecodesign Regulation (EU) No. 2016/2281 for Comfort applications**

SEPR<sub>-2/-8 °C</sub> **Values in bold comply with Ecodesign Regulation (EU) No. 2015/1095 for HT applications**

IPLV.SI Calculated as per AHRI standard 551-591.

(1) In dB ref=10<sup>-12</sup> W, (A) weighting. Declared dual-number noise emission value in accordance with ISO 4871 with an uncertainty of +/-3 dB(A). Measured in accordance with ISO 9614-1 and certified by Eurovent.

(2) In dB ref 20 µPa, (A) weighting. Declared dual-number noise emission value in accordance with ISO 4871 with an uncertainty of +/-3 dB(A). For information, calculated from the sound power Lw(A).



Eurovent certified values



## PHYSICAL DATA, SIZES 040R TO 160R

30RB		040R	045R	050R	055R	060R	070R	080R	090R	100R	120R	140R	160R
<b>Operating weight <sup>(3)</sup></b>													
Standard unit	kg	408	409	428	428	435	446	454	672	734	743	861	877
Unit + single high-pressure pump option	kg	428	429	448	448	455	466	474	692	754	768	886	902
Unit + dual high-pressure pump option	kg	455	456	475	475	482	493	501	719	781	790	908	924
Unit + single high-pressure pump and buffer tank options	kg	763	765	784	784	791	801	810	1087	1149	1163	1281	1297
Unit + dual high-pressure pump and buffer tank options	kg	790	792	811	811	818	828	837	1114	1176	1185	1303	1319
<b>Compressors</b>													
Hermetic Scroll 48,3 r/s													
Circuit A		2	2	2	2	2	2	2	2	3	3	2	2
Circuit B												2	2
No. of power stages		2	2	2	2	2	2	2	2	3	3	4	4
<b>Refrigerant<sup>(3)</sup></b>													
R-32 / A2L/ PRP= 675 in accordance with AR4													
Circuit A	kg	3,72	3,92	4,43	4,90	4,70	4,87	4,84	7,75	8,40	9,00	5,00	5,07
	tCO <sub>2</sub> e	2,5	2,6	3,0	3,3	3,2	3,3	3,3	5,2	5,7	6,1	3,4	3,4
Circuit B	kg											5,00	5,07
	tCO <sub>2</sub> e											3,4	3,4
<b>Oil</b>													
POE													
Circuit A	l	6,00	6,00	6,60	6,60	6,60	7,20	7,20	7,20	10,80	10,80	7,20	7,20
Circuit B	l											7,20	7,20
<b>Capacity control</b>													
SmartVu™													
Minimum capacity	%	50	50	50	50	50	50	50	50	33	33	25	25
<b>PED category</b>													
III													
<b>Condenser</b>													
All-aluminium micro-channel coils (MCHE)													
<b>Fans</b>													
Axial Flying bird™ 6 with rotating shroud													
<b>Standard unit</b>													
Quantity		1	1	1	1	1	1	1	2	2	2	2	2
Maximum total air flow	l/s	3882	3802	4058	3900	5484	5452	5414	10568	10512	10974	10904	10827
Maximum rotation speed	r/s	12	12	12	12	16	16	16	16	16	16	16	16
<b>Evaporator</b>													
Direct expansion brazed-plate heat exchanger													
Water volume	l	3,55	4	4,44	4,44	5,18	6,07	6,96	7,4	8,44	9,92	12,69	14,31
Max. water-side operating pressure without hydronic module	kPa	1000	1000	1000	1000	1000	1000	1000	1000	1000	1000	1000	1000
<b>Hydronic module (option)</b>													
Pump, Victaulic screen filter, relief valve, water and air vent valve, pressure sensors													
Centrifugal pump, monocell, 48,3 r/s, low- or high-pressure (as required), single or dual (as required)													
Expansion tank volume (Option 293)	l	12	12	12	12	12	12	12	35	35	35	35	35
Buffer tank volume (Option 307)	l	208	208	208	208	208	208	208	208	208	208	208	208
Max. water-side operating pressure with hydronic module	kPa	400	400	400	400	400	400	400	400	400	400	400	400
<b>Water connections with or without hydronic module</b>													
Victaulic® type													
Connections	inches	2	2	2	2	2	2	2	2	2	2	2	2
External diameter	mm	60,3	60,3	60,3	60,3	60,3	60,3	60,3	60,3	60,3	60,3	60,3	60,3
<b>Casing paint colour</b>													
Colour code RAL 7035													

(3) Values are guidelines only. Refer to the unit name plate.

## PHYSICAL DATA, SIZES 040R TO 160R

30RQ			040R	045R	050R	060R	070R	080R	090R	100R	120R	140R	160R	
<b>Standard unit</b>														
Heating Full load performances*	HA1	Nominal capacity	kW	44,1	47,9	54,3	61,6	68,2	61,8	93,3	106,6	119,1	136,8	123,1
		COP	kW/kW	3,91	3,97	3,89	3,80	3,81	3,03	3,80	3,80	3,80	3,80	3,80
	HA2	Nominal capacity	kW	42,7	47,0	53,5	59,5	67,2	75,7	91,7	104,5	117,6	134,9	150,2
		COP	kW/kW	3,07	3,16	3,12	3,01	3,08	3,01	3,10	3,09	3,09	3,08	3,08
Seasonal energy efficiency**	HA1	SCOP <sub>30/35°C</sub>	kWh/kWh	3,82	3,85	3,81	3,58	3,67	3,65	3,61	3,56	3,79	3,76	3,78
		η <sub>s</sub> heat <sub>30/35°C</sub>	%	150	151	149	140	144	143	141	139	149	147	148
		P <sub>rated</sub>	kW	31,6	33,5	36,4	42,7	49,8	55,0	59,9	68,4	87,0	99,6	109,3
Cooling Full load performances*	CA1	Nominal capacity	kW	41,0	43,1	50,3	60,2	65,2	74,3	87,0	99,9	114,2	131,6	147,2
		EER	kW/kW	2,89	2,69	2,66	2,97	2,90	2,66	2,88	2,84	2,93	2,85	2,66
Seasonal energy efficiency**		SEER <sub>12/7 °C</sub> Comfort low temp.	kWh/kWh	4,19	4,23	4,18	4,34	4,25	4,03	4,48	4,86	4,88	4,20	4,09
		SEPR <sub>12/7 °C</sub> Process high temp.	kWh/kWh	6,08	5,93	5,69	6,13	5,87	5,39	5,82	5,82	5,89	5,48	5,24
<b>Unit with Heating Optimized option 119D</b>														
Heating Full load performances*	HA1	Nominal capacity	kW	44,4	48,2	54,6	62,2	68,9	62,3	94,4	107,8	120,5	137,4	123,3
		COP	kW/kW	4,02	4,09	3,99	3,93	3,92	3,15	3,94	3,87	3,88	3,90	3,13
	HA2	Nominal capacity	kW	43,1	47,4	53,9	60,2	67,9	76,3	92,9	105,8	119,0	135,6	151,1
		COP	kW/kW	3,18	3,29	3,23	3,15	3,20	3,17	3,25	3,18	3,18	3,20	3,15
Seasonal energy efficiency**	HA1	SCOP <sub>30/35°C</sub>	kWh/kWh	3,97	4,00	3,96	3,78	3,88	3,89	3,77	3,71	3,95	3,98	4,00
		η <sub>s</sub> heat <sub>30/35°C</sub>	%	156	157	155	148	152	153	148	145	155	156	157
		P <sub>rated</sub>	kW	31,7	33,6	36,4	42,9	50,0	55,1	60,3	68,8	87,5	99,8	109,4
Cooling Full load performances*	CA1	Nominal capacity	kW	38,9	41,1	48,1	57,5	62,7	71,8	83,4	96,0	109,6	127,1	142,7
		EER	kW/kW	2,75	2,57	2,56	2,85	2,80	2,59	2,77	2,74	2,83	2,76	2,58
Seasonal energy efficiency**		SEER <sub>12/7 °C</sub> Comfort low temp.	kWh/kWh	3,95	4,00	3,98	4,15	4,06	3,89	4,29	4,63	4,66	4,10	4,02
		SEPR <sub>12/7 °C</sub> Process high temp.	kWh/kWh	5,68	5,56	5,39	5,79	5,56	5,17	5,52	5,49	5,58	5,33	5,16
<b>Sound levels</b>														
<b>Unit + option 16</b>														
Sound power <sup>(1)</sup>			dB(A)	82	83	84	89	89,5	89,5	92	92	92	92,5	92
Sound pressure at 10 m <sup>(2)</sup>			dB(A)	50	52	53	58	58	58	60	61	60	61	60,0
<b>Standard unit</b>														
Sound power <sup>(1)</sup>			dB(A)	82	83	84	89	89,5	89,5	92	92	92	92,5	92
Sound pressure at 10 m <sup>(2)</sup>			dB(A)	50	52	53	58	58	58	60	61	60	61	60,0
<b>Unit + option 15LS<sup>(3)</sup></b>														
Sound power <sup>(1)</sup>			dB(A)	78,5	79	80,5	80,5	80,5	80,5	83,5	83,5	83,5	83,5	83,5
Sound pressure at 10 m <sup>(2)</sup>			dB(A)	47	48	49	49	49	49	52	52	52	52	52

\* In accordance with standard EN14511-3:2022.

\*\* In accordance with EN14825:2022, average climatic conditions.

HA1 Heating mode conditions: Water type heat exchanger water inlet/outlet temperature 30 °C/35 °C, outdoor air temperature tdb/twb = 7 °C db/6 °C wb, evaporator fouling factor 0 m<sup>2</sup>. k/W

HA2 Heating mode conditions: Water type heat exchanger water inlet/outlet temperature 40 °C/45 °C, outdoor air temperature tdb/twb = 7 °C db/6 °C wb, evaporator fouling factor 0 m<sup>2</sup>. k/W

CA1 Cooling mode conditions: evaporator water inlet/outlet temperature 12 °C/7 °C, outdoor air temperature 35 °C, evaporator fouling factor 0 m<sup>2</sup>. k/W

η<sub>s</sub> heat<sub>30/35°C</sub> & SCOP<sub>30/35°C</sub> Values in bold comply with Ecodesign Regulation (EU) No. 813/2013 for Heating applications

SEER<sub>12/7 °C</sub> & SEPR<sub>12/7 °C</sub> Applicable Ecodesign regulation (EU) No. 2016/2281

(1) In dB ref=10<sup>-12</sup> W, (A) weighting. Declared dual-number noise emission value in accordance with ISO 4871 with an uncertainty of +/-3 dB(A). Measured in accordance with ISO 9614-1 and certified by Eurovent.

(2) In dB ref 20 µPa, (A) weighting. Declared dual-number noise emission value in accordance with ISO 4871 with an uncertainty of +/-3 dB(A). For information, calculated from the sound power Lw(A).

(3) Options: 15LS = Very low noise level, 116W = Variable-speed high pressure dual-pump hydraulic module, 307 = Water buffer tank module



Eurovent certified values

## PHYSICAL DATA, SIZES 040R TO 160R

30RQ		040R	045R	050R	060R	070R	080R	090R	100R	120R	140R	160R
<b>Dimensions</b>												
<b>Standard unit</b>												
Length	mm	2109	2109	2109	2109	2109	2109	2275	2275	2275	2275	2275
Width	mm	1090	1090	1090	1090	1090	1090	2125	2125	2125	2125	2125
Height	mm	1330	1330	1330	1330	1330	1330	1330	1330	1330	1330	1330
Unit height (option 12)	mm	1372	1372	1372	1372	1372	1372	1372	1372	1372	1372	1372
Unit height (option 307)	mm	1931	1931	1931	1931	1931	1931	1931	1931	1931	1931	1931
Unit height (option 12 +307)	mm	1973	1973	1973	1973	1973	1973	1973	1973	1973	1973	1973
<b>Operating weight<sup>(4)</sup></b>												
Standard unit	kg	444	446	469	496	506	515	759	818	866	996	1000
Unit + single high-pressure pump option	kg	464	466	489	516	526	535	779	838	891	1021	1025
Unit + dual high-pressure pump option	kg	491	493	516	543	553	562	805	864	923	1054	1058
Unit + single high-pressure pump and buffer tank options	kg	800	802	825	852	862	871	1174	1233	1286	1416	1420
Unit + dual high-pressure pump and buffer tank options	kg	827	829	852	879	889	898	1200	1259	1318	1449	1453
<b>Compressors</b>												
Hermetic Scroll 48,3 r/s												
Circuit A		2	2	2	2	2	2	2	3	3	2	2
Circuit B											2	2
No. of power stages		2	2	2	2	2	2	2	3	3	4	4
<b>Refrigerant<sup>(4)</sup></b>												
R-32 / A2L/ PRP= 675 in accordance with AR4												
Circuit A	kg	7,30	7,30	7,80	8,70	8,95	9,20	15,20	15,70	19,60	8,95	9,15
	tCO <sub>2</sub> e	4,9	4,9	5,3	5,9	6,0	6,2	10,3	10,6	13,3	6,0	6,2
Circuit B	kg										8,95	9,15
	tCO <sub>2</sub> e										6,0	6,2
<b>Oil</b>												
Oil type												
Circuit A	l	6,0	6,0	6,6	6,6	7,2	7,2	7,2	10,8	10,8	7,2	7,2
Circuit B	l										7,2	7,2
<b>Capacity control</b>												
SmartVu™												
Minimum capacity	%	50	50	50	50	50	50	50	33	33	25	25
<b>PED category</b>												
III												
<b>Condenser</b>												
Grooved copper tubes and aluminium fins												
<b>Fans</b>												
Axial Flying bird™ 6 with rotating shroud												
<b>Standard unit</b>												
Quantity		1	1	1	1	1	1	2	2	2	2	2
Maximum total air flow	l/s	4034	4034	4034	5613	5613	5613	10904	10904	10904	11226	11226
Maximum rotation speed	r/s	12	12	12	16	16	16	16	16	16	16	16
<b>Evaporator</b>												
Dual-circuit plate heat exchanger												
Water volume	l	3,55	4	4,44	5,18	6,07	6,96	7,4	8,44	9,92	12,69	14,31
Max. water-side operating pressure without hydronic module	kPa	1000	1000	1000	1000	1000	1000	1000	1000	1000	1000	1000
<b>Hydronic module (option)</b>												
Pump, Victaulic screen filter, relief valve, water and air vent valve, pressure sensors												
Centrifugal pump, monocell, 48,3 r/s, low- or high-pressure (as required), single or dual (as required)												
Expansion tank volume (Option 293)	l	12	12	12	12	12	12	35	35	35	35	35
Buffer tank volume (Option 307)	l	208	208	208	208	208	208	208	208	208	208	208
Max. water-side operating pressure with hydronic module	kPa	400	400	400	400	400	400	400	400	400	400	400
<b>Water connections with or without hydronic module</b>												
Victaulic® type												
Connections	inches	2	2	2	2	2	2	2	2	2	2	2
External diameter	mm	60,3	60,3	60,3	60,3	60,3	60,3	60,3	60,3	60,3	60,3	60,3
<b>Casing paint colour</b>												
Colour code RAL 7035 & 7024												

(3) Options: 15LS = Very low noise level, 116W = Variable-speed high pressure dual-pump hydraulic module, 307 = Water buffer tank module,

(4) Values are guidelines only. Refer to the unit name plate.

## ELECTRICAL SPECIFICATIONS

30RB/30RQ		040R	045R	050R	055R	060R	070R	080R	090R	100R	120R	140R	160R
<b>Power circuit supply</b>													
Nominal voltage	V-ph-Hz	400 - 3 - 50											
Voltage range	V	360 - 440											
<b>Control circuit supply</b>													
24 V via internal transformer													
<b>Maximum operating input power<sup>(1) or (2)</sup></b>													
Circuit A&B	kW	19	21	24	24	28	31	36	41	48	55	63	71
<b>Power factor at maximum power<sup>(1) or (2)</sup></b>													
Displacement Power Factor (Cos Phi), standard unit		0,81	0,82	0,82	0,82	0,84	0,84	0,85	0,82	0,84	0,85	0,84	0,85
<b>Nominal unit current draw<sup>(4)</sup></b>													
Standard unit	A	26	29	35	35	36	46	52	59	71	81	91	104
<b>Maximum operating current draw (Un)<sup>(1) or (2)</sup></b>													
Standard unit	A	34	37	42	42	48	54	60	72	84	93	108	121
<b>Maximum current (Un-10%)<sup>(1) or (2)</sup></b>													
Standard unit	A	37	39	44	44	51	58	65	77	89	99	115	129
<b>Maximum start-up current (Un)<sup>(2) + (3)</sup></b>													
Standard unit	A	116	118	165	165	169	177	191	238	206	223	231	251

(1) Values at the unit's permanent maximum operating condition (as shown on the unit's nameplate).

(2) Values at the unit's maximum operating condition (as shown on the unit's nameplate).

(3) Maximum operating current of the smallest compressor(s) + fan current + locked rotor current of the largest compressor.

(4) Standardised EUROVENT conditions, water-cooled exchanger inlet/outlet = 12 °C/7 °C, outdoor air temperature = 35 °C.

### Short-circuit withstand current (TN system)<sup>(1)</sup>

30RB/30RQ		040R	045R	050R	055R	060R	070R	080R	090R	100R	120R	140R	160R	
<b>Rated short-circuit withstand currents</b>														
Rated short time (1s) current - I <sub>cw</sub>	kA eff	3,36	3,36	3,36	3,36	3,36	3,36	5,62	5,62	5,62	5,62	5,62	5,62	
Rated peak current - I <sub>pk</sub>	kA pk	20	20	20	20	20	20	15	20	20	15	20	15	
<b>Value with upstream electrical protection <sup>(1)</sup></b>														
Rated conditional short circuit current I <sub>cc</sub>	kA eff	40	40	40	40	40	40	40	40	40	40	30	30	
Associated protection - type/supplier		Circuit breaker/Schneider												
Associated protection - rating/reference		NS100H	NS100H	NS100H	NS100H	NS100H	NS100H	NS100H	NS100H	NS100H	NS160H	NS160H	NS250H	NS250H

(1) If another current limitation protection device is used, its time-current and thermal constraint (I<sup>2</sup>t) trip characteristics must be at least equivalent to those of the recommended protection.

**Note: The short circuit current withstand capability values above have been established for the TN system.**

## DIMENSIONS/CLEARANCES

### 30RB/30RQ 040R-080R, units without water buffer tank module

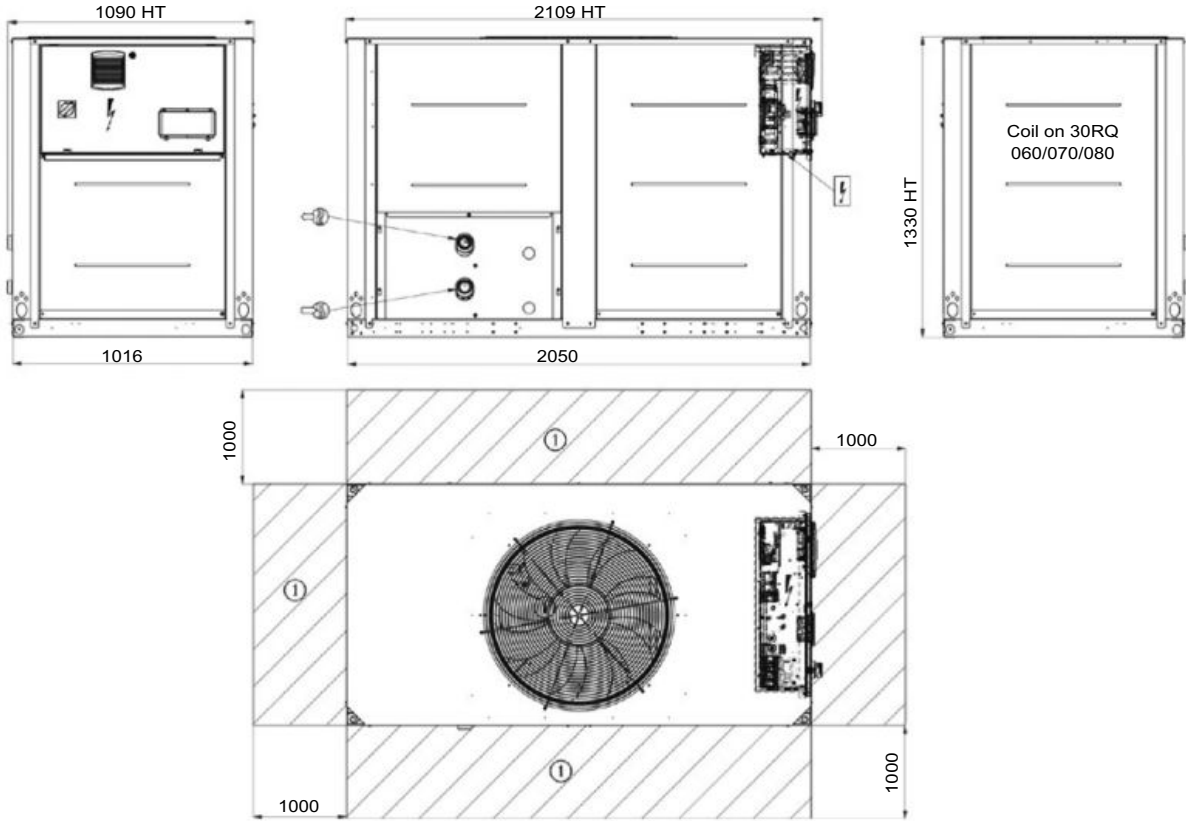

**Key:**

All dimensions are given in mm.

- ① Clearances required for maintenance and air flow
- ② Clearance recommended for coil removal
- Water inlet
- Water outlet
- Air outlet, do not obstruct
- Control box

**NOTE: Non-contractual drawings.**

When designing a system, refer to the certified dimensional drawings provided with the unit or available on request.

Refer to the certified dimensional drawings for:

- The location of the fixing points,
- The weight distribution,
- The coordinates of the centre of gravity, hydraulic and electrical connections,
- Details of the 12/12A/23B option connections.



## DIMENSIONS/CLEARANCES

### 30RB/30RQ 090R-160R, units without water buffer tank module

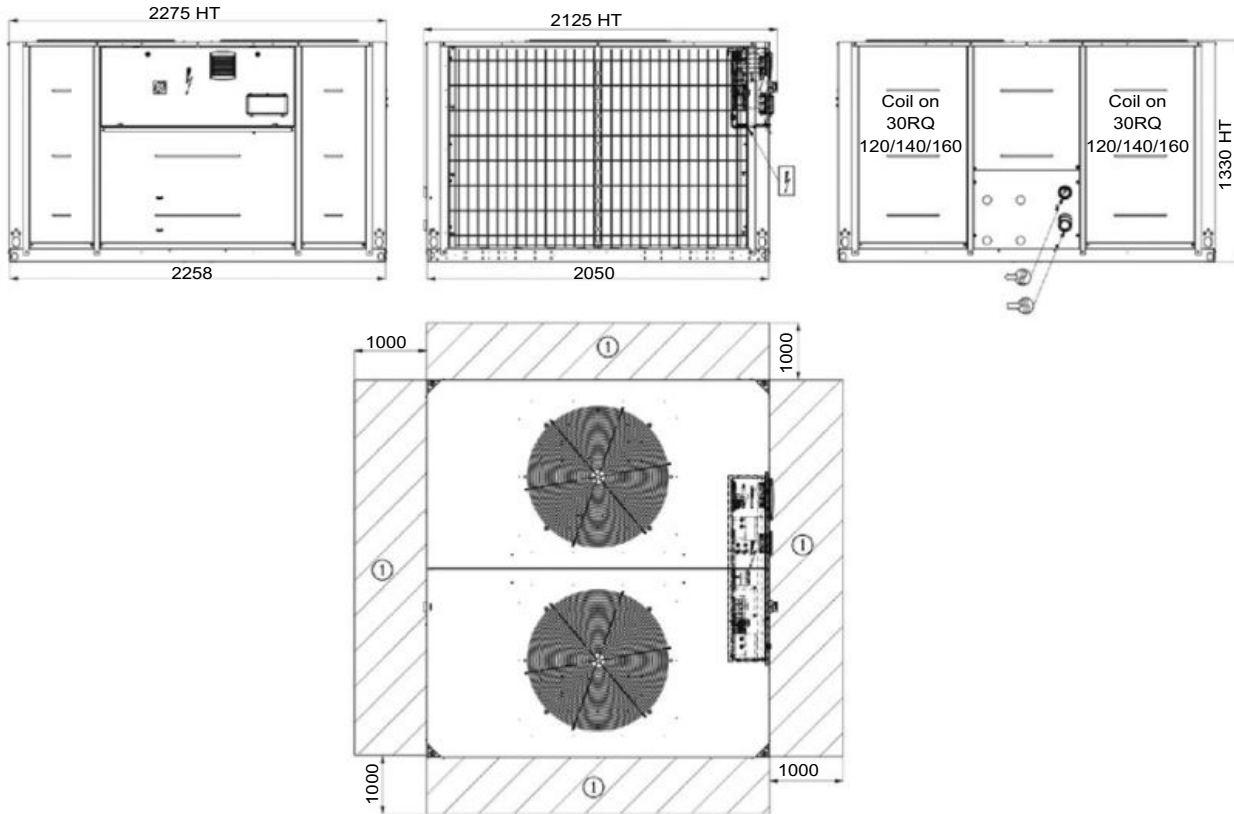

**Key:**

All dimensions are given in mm.

- ① Clearances required for maintenance and air flow
- ② Clearance recommended for coil removal
- Water inlet
- Water outlet
- Air outlet, do not obstruct
- Control box

**NOTE: Non-contractual drawings.**

When designing a system, refer to the certified dimensional drawings provided with the unit or available on request.

Refer to the certified dimensional drawings for:

- The location of the fixing points,
- The weight distribution,
- The coordinates of the centre of gravity, hydraulic and electrical connections,
- Details of the 12/12A/23B option connections.

## DIMENSIONS/CLEARANCES

### 30RB/30RQ 040R-080R, units with water buffer tank module

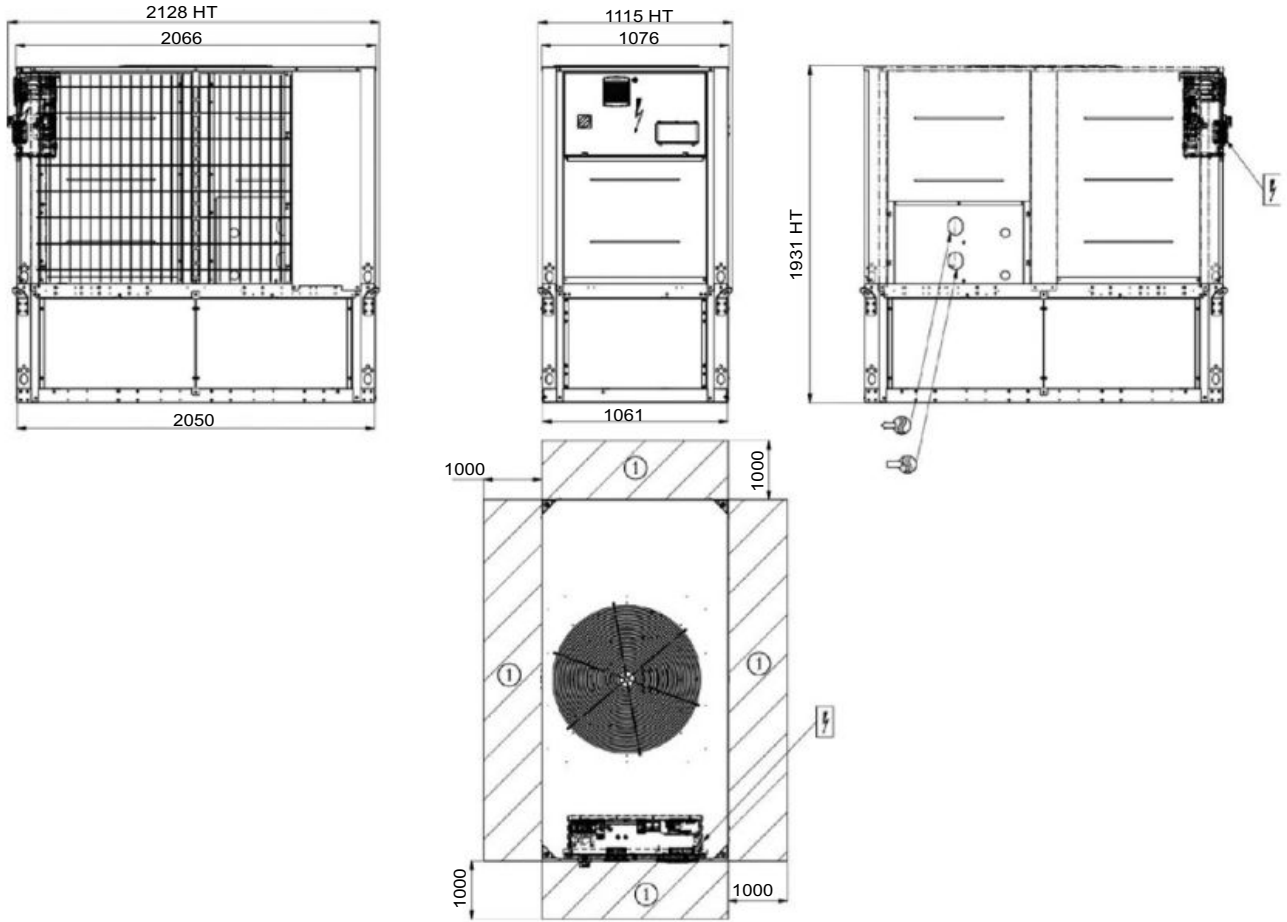

**Key:**

All dimensions are given in mm.

- ① Clearances required for maintenance and air flow
- ② Clearance recommended for coil removal
- Water inlet
- Water outlet
- Air outlet, do not obstruct
- Control box

**NOTE: Non-contractual drawings.**

When designing a system, refer to the certified dimensional drawings provided with the unit or available on request.

Refer to the certified dimensional drawings for:

- The location of the fixing points,
- The weight distribution,
- The coordinates of the centre of gravity, hydraulic and electrical connections,
- Details of the 12/12A/23B option connections.

## DIMENSIONS/CLEARANCES

### 30RB/30RQ 090R-160R, units with water buffer tank module

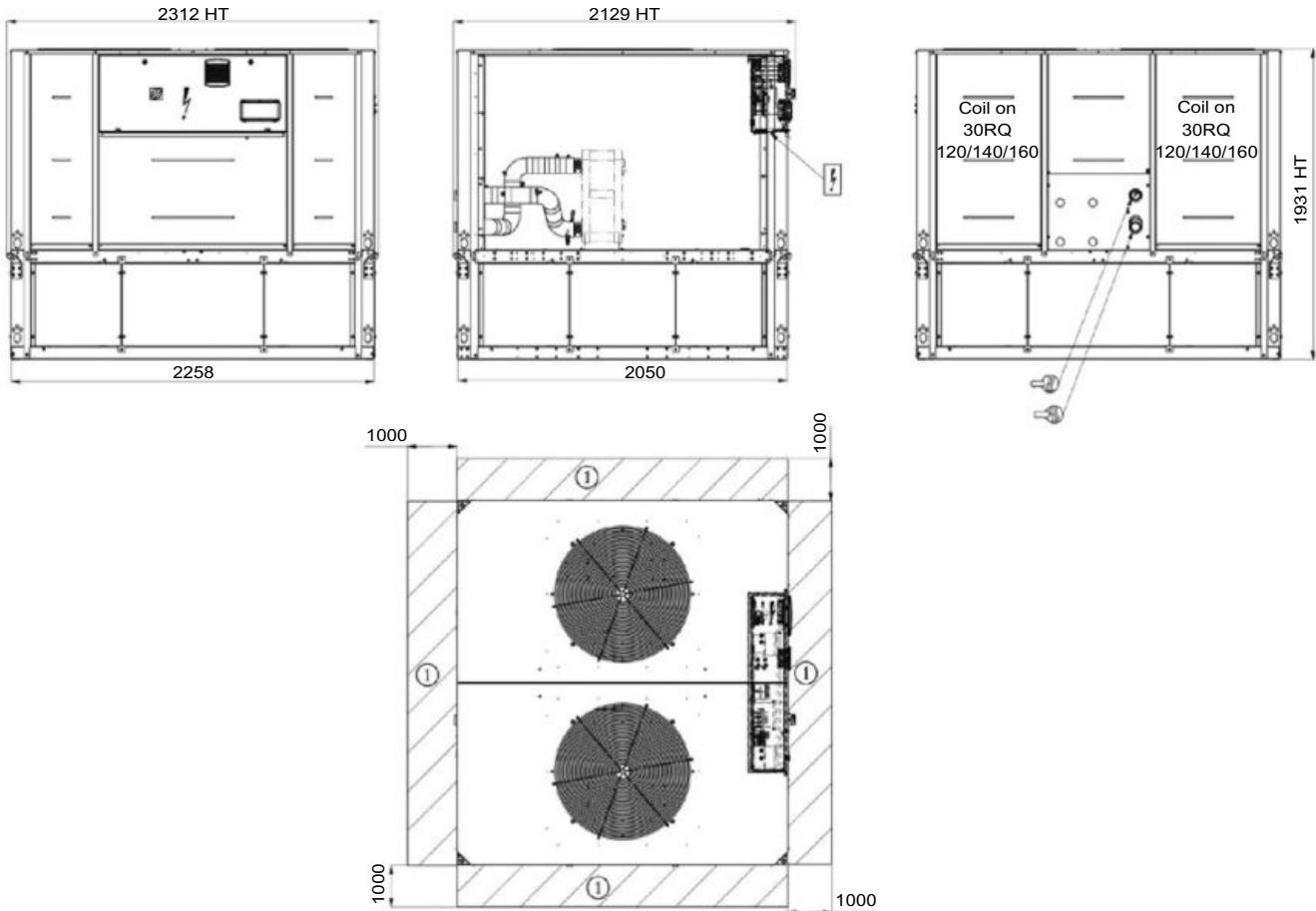

#### Key:

All dimensions are given in mm.

- ① Clearances required for maintenance and air flow
- ② Clearance recommended for coil removal
- Water inlet
- Water outlet
- Air outlet, do not obstruct
- Control box

#### NOTE: Non-contractual drawings.

When designing a system, refer to the certified dimensional drawings provided with the unit or available on request.

Refer to the certified dimensional drawings for:

- The location of the fixing points,
- The weight distribution,
- The coordinates of the centre of gravity, hydraulic and electrical connections,
- Details of the 12/12A/23B option connections.



## HEAT PUMPS WITH GREENSPEED® INTELLIGENCE



Unit with low noise level option

Low environmental impact

High full and part load efficiency

Compact and simple to install

Low refrigerant charge

Superior reliability

## 30RQ/30RQP 165R-1040R

Heating capacity 180-1075 kW

Cooling capacity 160-1000 kW



Aquasnap® heat pumps and liquid chillers are the best solution for commercial and industrial applications where installers, engineering and design departments and building owners require reduced installation costs, optimal performances and maximum quality.

The latest generation AquaSnap® is available in two new versions:

- The AquaSnap® (30RB-30RQ) version is a compact all-in-one package optimised for full-load applications where reduced investment cost (low CapEx) is required.
- The premium AquaSnap® version with Greenspeed® intelligence (30RBP-30RQP) is optimised for part load applications where a high SEER, SEPR, SCOP or IPLV value is required. This version is equipped with a variable-speed pump and fans, providing premium part load efficiency to reduce maintenance costs over the lifespan of the chiller. In addition, the sound levels achieved under the part load conditions are particularly low. Besides operating efficiently and quietly, the AquaSnap® range with Greenspeed® intelligence operates from -20 °C up to +48 °C as standard.

\* The availability of sizes and options depends on the country. Please contact your local commercial dealer for more information.



CARRIER participates in the ECP programme for LCP-HP  
Check ongoing validity of certificate:  
[www.eurovent-certification.com](http://www.eurovent-certification.com)



## R-32: THE BEST SOLUTION FOR SCROLL LIQUID CHILLERS AND HEAT PUMPS



Carrier was the first to introduce the R-1234ze HFO with ultra-low GWP in screw chillers, as far back as early 2016. Today, having examined its main properties, Carrier has chosen R-32 refrigerant to replace high-GWP R-410A refrigerant in its Scroll liquid chillers and heat pumps, for its lower environmental impact, high energy efficiency, good availability and ease of use.

R-32 is currently the ideal refrigeration solution for units equipped with Scroll compressors. By using R-32 refrigerants, Carrier has reduced the carbon footprint of its AquaSnap® range of liquid chillers and heat pumps by 77%. This is the result of a much lower GWP and a significant reduction in the system's cooling load compared to the previous generation that used R-410A.

R-32 is also the right choice economically, reducing the locally imposed tax burden on HFCs based on the CO<sub>2</sub> impact.



**CO<sub>2</sub> FOOTPRINT**  
REDUCED BY UP TO **-77%**

### Lower environmental impact (-77% compared to R410A)

- R-32 has zero ozone depletion potential (ODP)
- The Global Warming Potential (GWP) of R-32 is 675, i.e. approximately one third of that of R-410A (PRP 2088)
- The AquaSnap® R-32 cooling load is reduced by 30% compared to the previous version using R-410A<sup>(1)</sup>
- The carbon footprint of AquaSnap® R-32 is therefore 473 (675 x 0.7), i.e. 77% lower than the version using R-410A (2088 x 1)

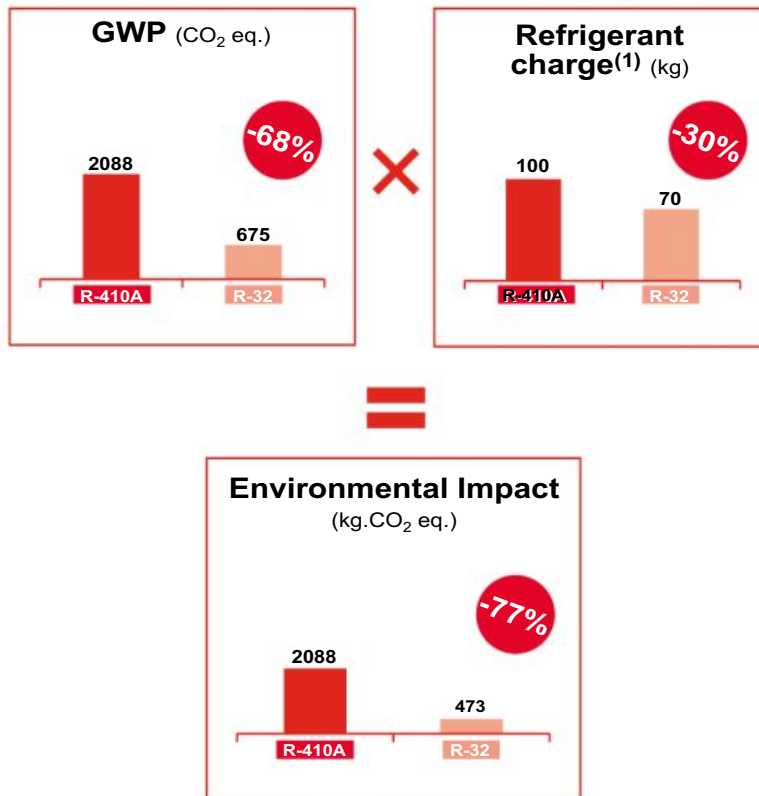

(1) Reduced refrigerant charge in Carrier heat pumps thanks to the use of R-32 and a new coil design.

## R-32: THE BEST SOLUTION FOR SCROLL LIQUID CHILLERS AND HEAT PUMPS



**SEER** up to **+10%**  
**SCOP** up to **+6%**

### High energy efficiency

The seasonal efficiency of AquaSnap® R-32 is higher than that of the previous R-410A version by:

- Approximately +10% in cooling mode
- Approximately +6% in heating mode

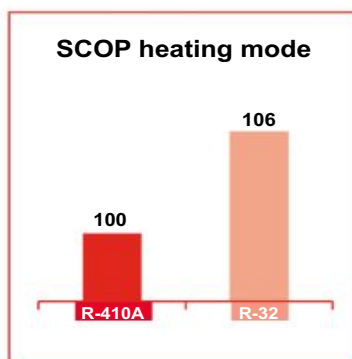
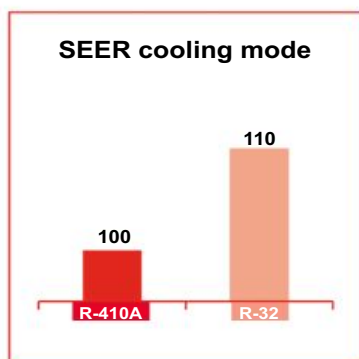

### SIMPLICITY

### Widely available and easy to use

More than 50 million R-32 air conditioning units are in circulation on the global market. While R-32 has been used for some time in residential and commercial air conditioning units, most manufacturers now use R-32 in VRF systems, liquid chillers and heat pumps, which means R-32 is widely available around the world.

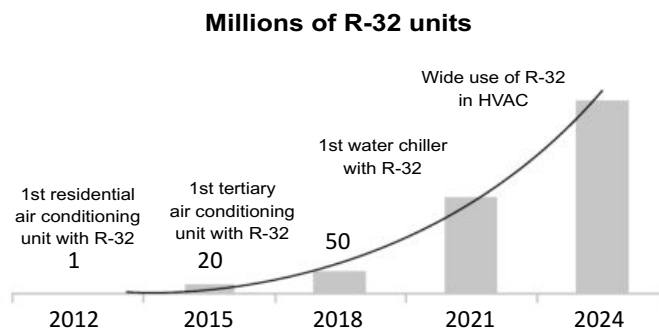

R-32 has been widely available for over 15 years, as it comprises 50% of the composition of R-410A.

R-32 is easy to use: It is a pure refrigerant, therefore it is not necessary to drain the entire circuit in the event of a leak.



### SAFETY

R-32 is an A2L classified refrigerant thanks to its low flammability.

- **No specific safety requirements** for transporting chillers by road.
- **Easy outdoor installation** in line with the requirements of standard EN 378.
- The service tools must be **certified for A2L** refrigerants in accordance with standard ISO 817 or EN378.
- Service technicians **must be qualified for brazing components** on PED 2 fluid units.

## AQUASNAP® - CUSTOMER BENEFITS

### Outstanding performance

Equipped with variable-speed fans (VSD as standard and EC optional) and optional variable-speed pumps, Carrier's AquaSnap® 30RBP/RQP range with Greenspeed® intelligence automatically adjusts the cooling capacity and water flow to perfectly adapt to the building's requirements or load variations. The result is optimum operation at both full load and part load (SEER up to 5.4, SCOP of 3.9). The 30RBP/RQP offers energy efficiency up to 10% higher than the previous range with the same or a smaller footprint.

The range is already fully compliant with the 2021 Ecodesign regulations.

### Intelligence and connectivity

The advanced SmartVu™ intelligent control system displays operating parameters in real time, making it intuitive and particularly user-friendly. The AquaSnap® 30RBP/RQP range is also characterised by a brand new smart energy monitoring function which provides users with smart data such as electrical energy consumption in real time, supplied cooling and heating energy and instantaneous and average seasonal energy efficiency values. For even greater energy savings, the AquaSnap® 30RBP/RQP can be monitored remotely by Carrier experts to further optimise the energy consumption level.



SEER up to **5.4**  
SCOP up to **3.9**



SMART ENERGY  
MONITORING

### Extensive field of application

The AquaSnap® range is suitable for a very wide range of applications from tertiary to industrial processes. The range can operate at outdoor temperatures from -20 °C to +48 °C and with negative water temperatures (-8 °C). From high-end office buildings and hotels to healthcare facilities, data centers and industrial projects, AquaSnap® 30RBP/RQP units meet the most demanding expectations in terms of energy efficiency and savings, whatever the climate or application.

### Easy installation & maintenance

Thanks to the variable-speed pumps up to 950 kW, automatic adjustment of the nominal water flow rate via electronic control and automatic measurement of the unit's energy performance under real conditions, the pumping energy consumption is reduced by almost two thirds: these new features guarantee peace of mind for installers and maintenance companies and lower energy bills for users.



BETWEEN  
**-20 °C**  
and **48 °C**



Pumping energy  
reduced by  
up to **66%**

## AQUASNAP® - CUSTOMER BENEFITS

AquaSnap® liquid chillers and heat pumps are designed to meet current and future Ecodesign and F-Gas European regulation requirements in terms of energy efficiency and reduced CO<sub>2</sub> emissions. They use the best technologies available today:

- Reduced refrigerant charge of non-ozone depleting R-32A refrigerant with low GWP
- Scroll compressors
- Greenspeed® variable-speed fans (30RBP-30RQP models)
- NOVATION™ micro-channel heat exchangers with a new aluminium alloy (30RB/RBP)
- Brazed-plate heat exchangers with reduced pressure drops
- Self-regulating microprocessor control with Greenspeed® intelligence
- Colour touch screen with web connectivity options

Both AquaSnap® versions can be equipped with a built-in hydraulic module, limiting the installation to conventional operations such as connection of the power supply and the supply and return piping (plug & play), according to the dimensions of the standard unit.

Recommended by Carrier, the AquaSnap® can be equipped with one or two Greenspeed® variable-speed pumps to significantly reduce energy costs linked to pumping (reduction of more than two-thirds), ensure optimum water flow rate control, and improve overall system reliability.



### Very economical operation

- High unit full- and part-load energy efficiency and efficient design of the water side:
  - SEER<sub>12/7°C</sub> up to 5.4 (30RBP version) in accordance with the new Ecodesign 2016/2281 regulations and SCOP 35 °C up to 3.9 (30RQP version).
  - Multiple scroll compressors equipped with a high-efficiency motor which can exactly match the cooling capacity to the load required
  - Electronic expansion valve enabling operation at a lower condensing pressure and improved use of the evaporator heat transfer area (superheat control)
  - Condenser with high-efficiency NOVATION™ (30RB/RBP) aluminium micro-channel heat exchangers and Greenspeed® variable-speed fans (30RBP-30RQP version)
  - Low pressure drop brazed plate heat exchangers (< 45 kPa under Eurovent conditions).

- Specific control functions to reduce unit cooling energy use during occupied and unoccupied periods:
  - Internal timer: Switches the chiller on/off and controls operation at a second setpoint
  - Setpoint automatically offset based on the outdoor air temperature or room air temperature (via an option)
  - Floating high pressure (HP) management
  - Variable-speed fan control
  - Cooling demand limitation.

Refer to the control chapter for more information.

- Greenspeed® variable-speed pump to reduce pumping energy consumption by up to two-thirds (option recommended by Carrier):
  - Eliminate energy losses through the water flow rate control valve by electronically setting the nominal water flow rate
  - Save energy during stand-by periods or part-load operation by automatically reducing the water pump speed. The energy consumption of the pump motor varies according to the cube of the speed, so that a reduction in speed of just 40% can reduce energy consumption by 80%
  - Improved unit part-load performance (increased SEER/SCOP value with variable water flow according to standard EN14825).

Refer to the hydraulic option chapter for more information.



- Extra energy savings through multiple options:
  - Carrier dry cooler free cooling mode management
  - Partial or total heat recovery.
- Reduced maintenance costs:
  - Fast diagnosis of possible incidents and their history via the control
  - Programmable maintenance alert
  - Programmable F-Gas leak monitoring alert

## AQUASNAP® - CUSTOMER BENEFITS

### Low noise level

- Condenser with fixed-speed fans (30RB-30RQ):
  - Optional low-speed fans (700 rpm) and compressor enclosure to reduce full-load noise level by 6 to 7 dB(A)
  - Condenser coils in V-shape with an open angle, allowing quieter air flow across the coil
  - Low noise 6th generation Flying Bird™ fans, made of a composite material (Carrier patent)
  - Rigid fan installation for reduced noise (Carrier patent).
- Condenser with Greenspeed® variable-speed fans (30RBP-30RQP) recommended by Carrier for even quieter operation):
  - Optional factory setting of the fan at low speed, with compressor enclosure to reduce full-load noise level by 6 to 7 dB(A)
  - Exceptional acoustic signature during part-load operation through smooth fan speed variation.
- Specific control functions or features to reduce noise level during the night or unoccupied periods:
  - Night-time sound control with cooling capacity and fan speed limitation
  - Low-noise scroll compressors with low vibration level
  - The compressor assembly is installed on an independent chassis and supported by flexible anti-vibration mountings
  - Dynamic suction and discharge piping support, minimising vibration transmission (Carrier patent)
  - Acoustic compressor enclosure, reducing radiated noise emissions (optional).



### Quick and easy installation

- Compact design:
  - AquaSnap® units are designed with compact dimensions for easy installation.
  - With a length of approximately 4.8 m for 550 kW and a width of 2.25 m, the units require minimal floor space.
- Built-in hydraulic module (option):
  - Low or high pressure water pump (as required)
  - Single or dual pump (as required) with operation time balancing and automatic changeover to the back-up pump if a fault develops
  - Built-in variable-speed pumps with automatic nominal water flow adjustment via electronic control on the user display.
  - Water filter protects the water pump against circulating debris
  - Pressure sensors for direct numerical display of the water flow rate and water pressures
  - Thermal insulation and frost protection down to -20 °C, using a heater (optional)
  - High-capacity membrane expansion tank (option).

- Built-in hydraulic module with Greenspeed® variable-speed pump (option recommended by Carrier):
  - Quick and easy electronic setting of the nominal water flow rate when the unit is commissioned, thus eliminating the need to adjust the water flow rate control valve
  - Automatic control of the pump speed based on constant speed, constant pressure difference or constant temperature difference.
- Simplified electrical connections
  - A single power connection point without neutral
  - Main disconnect switch with high trip capacity
  - 24 V control circuit using a built-in transformer.
- Simplified hydraulic connections:
  - Victaulic type couplings on the exchanger;
  - Clearly identified and practical reference marks for water outlet and inlet connections;
- Fast unit commissioning
  - Systematic factory test before shipment
  - Quick-test function for step-by-step verification of the sensors, electrical components and motors.

### Reduced installation costs

- Optional Greenspeed® variable-speed pump with hydraulic module (option recommended by Carrier)
  - Cut costs relating to the water flow control valve
  - The design of the water system with variable primary flow (VPF) can provide significant installation cost savings compared with traditional constant primary systems with variable secondary circuits; elimination of the secondary distribution pump, etc.
  - Water system design with fan coil units fitted with 2-way valves instead of 3-way valves.
- No buffer tank required thanks to Carrier's advanced control algorithm
  - Minimum water loop volume reduced to 2.5 l/kW.

### Environmentally responsible

- AquaSnap® liquid chillers with Greenspeed® intelligence are a boost for green cities and contribute to a sustainable future. Combining a refrigerant charge up to 30% lower, with R-32 refrigerant with a GWP 70% lower than that of the previous version using R410A, and exceptional energy efficiency, this chiller significantly reduces energy consumption while reducing carbon dioxide emissions throughout its life cycle.
- The AquaSnap® liquid chiller is equipped with an automatic energy meter that indicates the instantaneous and overall cooling energy at the outlet, the instantaneous and overall electrical energy consumption, the instantaneous and average seasonal energy efficiency for monitoring and a unit performance check.
  - Pumping energy consumption can be reduced by up to 2/3 using Greenspeed® variable-speed pumps



## AQUASNAP® - CUSTOMER BENEFITS

- Lower refrigerant charge: the micro-channel technology used for condenser coils optimises heat transfer while minimising the refrigerant volume.
- Sealed refrigerant circuits:
  - Leaks are eliminated thanks to the absence of capillary tubes and the use of flare connections
  - Verification of pressure transducers and temperature sensors without transferring the refrigerant charge
  - Discharge line shut-off valve and liquid duct service valve for simplified maintenance
  - Qualified Carrier maintenance personnel to provide refrigerant servicing
  - ISO 14001 production plant
- Refrigerant leak detection: available as an option, this additional dry contact allows reporting of possible leaks. The leak detector (supplied externally) should be mounted in the most likely leak location.
- Self-regulating control
  - The control algorithm prevents excessive compressor cycling and reduces the quantity of water in the water loop (Carrier patent)
  - Automatic compressor unloading in case of abnormally high condensing pressure
  - Automatic fan speed adjustment in case of coil fouling (30RBP-30RQP models)
  - Soft fan start to increase unit lifetime (30RBP-30RQP models).
- Exceptional endurance tests:
  - To design critical components and sub-assemblies to minimise the risk of failure on site, Carrier uses specialised laboratories and advanced dynamic simulation tools.
  - To ensure that the units reach customer sites in the same condition as they are when tested in the factory, Carrier tests the machine behaviour during transportation over 250 km. The road test is based on a military standard and is the equivalent to 5000 km by truck on a normal road.
  - To guarantee the coil corrosion resistance, salt spray corrosion resistance tests are performed in the group's laboratory.
  - In addition, to maintain the unit's performance throughout its operating life whilst minimising maintenance costs, end users can access the "Connected Services" remote monitoring service.

### Superior reliability

- State-of-the-art concept
  - Two self-contained refrigerant circuits; the second one automatically takes over if the first one develops a fault, maintaining partial cooling in all circumstances
  - All compressor components are easily accessible on site, minimising downtime
  - All-aluminium Novation™ micro-channel heat exchanger (MCHE) (30RB-30RBP) with higher corrosion resistance than a conventional coil. The all-aluminium construction eliminates the formation of galvanic currents between aluminium and copper which can corrode the coil in saline or corrosive atmospheres
  - V-coil design to protect the coils against hail impact
  - Optional Enviro-shield® anti-corrosion coil coating for use in moderately corrosive environments. Coating applied through conversion process which modifies the surface of the aluminium producing a coating that is integral to the coil. Immersion in a bath to ensure 100% coverage. No heat transfer variation, tested for 4000 hours in salt spray per ASTM B117
  - Optional Super Enviro-shield® anti-corrosion coil coating for use in extremely corrosive environments. Extremely durable and flexible epoxy polymer coating applied on the outer surface of the coil using an electro coating process with a final UV protective topcoat. Minimal heat transfer variation, tested for 6000 hours in salt spray per ASTM B117, superior impact resistance per ASTM D2794
  - Electronic flow switch. Auto-setting according to cooler size and fluid type.

### Designed to support Green Building Design

A green building is a building that is environmentally sustainable and is designed, constructed and operated to minimise the total impact on the environment.

The resulting building will be economical to operate, offer increased comfort and create a healthier environment for the people who live and work there, increasing productivity.

The air conditioning system can use between 30 and 40% of the annual building energy consumption. Choosing the right air conditioning system is one of the main considerations when designing a green building. For buildings with a load that varies throughout the year, the AquaSnap® 30RBP/RQP unit offers a solution to this important challenge.

A number of green building certification programmes exist in the market and offer third-party assessment of green building measures for a wide variety of building types.

The following example looks at how Carrier's new AquaSnap® range helps customers affected by the LEED® building certification.

## AQUASNAP® - CUSTOMER BENEFITS

### Energy saving certificate

The AquaSnap® 30RBP/RQP unit is eligible for energy saving certificates in France (CEE) in comfort, industrial and agriculture applications:

- Floating High pressure control (by modulating the air flow through fan activation and speed)
- Floating Low pressure control
- Variable speed on asynchronous fan motor
- Variable speed on asynchronous pump motor
- Partial or total recovery of energy

For more details about financial incentives in France, please refer to the "CEE product sheet".

### AquaSnap® and LEED® certification

The LEED® (Leadership in Energy and Environmental Design) green building certification programme is a major initiative set up to assess the design, construction and operation of green buildings with points assigned in seven credit categories:

- Sustainable Sites (SS),
- Water efficiency (WE),
- Energy and atmosphere (EA),
- Materials and resources (MR)
- Indoor environmental quality (IEQ)
- Innovation in design (ID)
- Regional Priority (RP).

There are a number of different LEED® products.

While the strategies and categories assessed remain the same, the distribution of points varies depending on the type of building and the requirements of the application, based on whether it is a new construction, school, core & shell, retail or healthcare.

All programmes now use the same point scale:

#### 110 LEED® points available

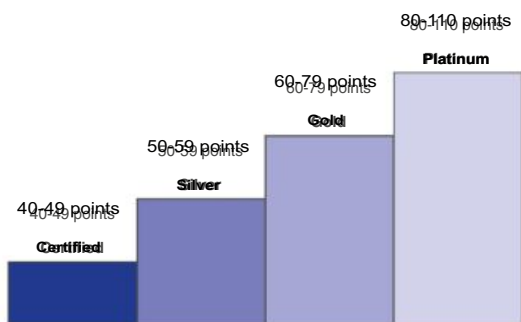

The majority of credits in LEED® rating systems are performance-based and achieving them is dependent on the impact of each component or sub-system on the building as a whole.

While the LEED® green building certification programmes do not certify products or services, choosing the right products, systems or service programmes is critical to obtaining LEED® certification for a registered project, because the right products or service programmes can help meet the goals of green construction and ongoing operation and maintenance.

The choice of heating, ventilation and air conditioning (HVAC) products in particular can have a significant impact on LEED® certification, as the HVAC system directly impacts two categories that together influence 40% of the available points.

### EcoPassport®

The PEP ecopassport® programme provides an international reference framework for procedures enabling manufacturers to report the environmental specifications of their products in the form of an environmental claim known as a Product Environmental Profile (PEP).

The PEP ecopassport® programme guarantees that PEPs are correctly drawn up, verified and reported in line with the requirements of the ISO 14025 and IEC/PAS 62545 standards.

The Life Cycle Analysis (LCA) PEP is the environmental identity card for an item of equipment which details the environmental impacts of the product during its life cycle according to eight mandatory indicators:

1. Global Warming Potential
2. Impact on the ozone layer
3. Acidification of soil and water
4. Eutrophication of water
5. Photochemical ozone creation
6. Abiotic resource depletion
7. Fresh water consumption
8. Total use of primary energy during the life cycle

Products with certified environmental profiles are used to support methods to assess building sustainability such as BREEAM, LEED. BREEAM, LEED gives additional recognition for materials with robust environmental product declaration types using manufacturer data.

Carrier is the first HVAC manufacturer to provide PEPs for liquid chillers and heat pumps with not only the 8 mandatory indicators, but all 27 indicators.

The PEP for the AquaSnap® 30RBP can be downloaded from the PEP ecopassport® website: <http://www.pep-ecopassport.org/fr/>

## AQUASNAP® - CUSTOMER BENEFITS

### Designed to support Green Building Design

#### Overview of LEED® for new construction and major renovations

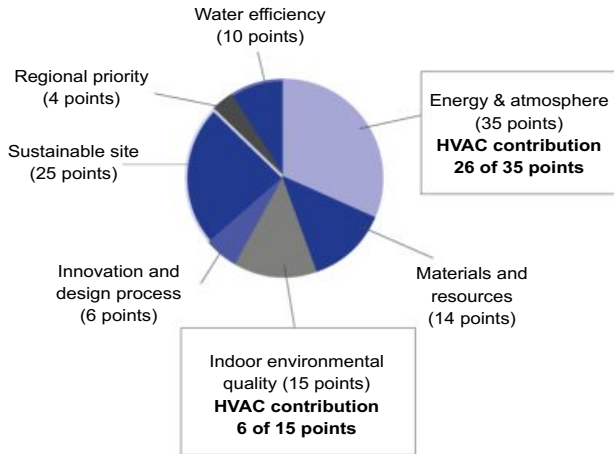

The new AquaSnap® units from Carrier can help building owners to earn LEED® points in particular in the Energy & Atmosphere (EA) credit category and help address the following prerequisites and credit requirements:

- EA prerequisite 2: minimum energy performance
- 30RBP/RQP units exceed the energy efficiency requirements of ASHRAE 90.1-2007; therefore they satisfy the prerequisites.
- EA prerequisite 3: fundamental refrigerant management  
30RBP/RQP units do not use chlorofluorocarbon (CFC) refrigerants, thus satisfying the prerequisites.
- EA credit 1: Optimise energy performance (1 to 19 points)  
Points for this credit are assigned depending on the energy cost reduction virtually achievable by the new building, compared to ASHRAE 90.1-2007 reference. 30RBP/RQP units, which are designed for high performance especially during part load operation, help to reduce the building's energy consumption and therefore to gain points for this credit. In addition, the Carrier HAP (Hourly Analyses Program) can be used to analyse energy. It meets the modelling requirements for this credit and produces reports which can be easily transferred to LEED® charts.
- EA credit 4: Enhanced refrigerant management (2 points)  
With this credit, LEED® awards systems that minimise the installed system's Ozone Depletion Potential (ODP) and Global Warming Potential (GWP). 30RBP/RQP units use a reduced R-32 charge and therefore help satisfy the requirements of this LEED® credit.

**NOTE:** This section describes the prerequisites and credit requirements in LEED® for new construction and is directly related to 30RBP/RQP units. Other prerequisites and credit requirements are not directly and purely related to the air conditioning unit itself, but more to the control of the HVAC system as a whole.

I-Vu®, Carrier's open control system, has features that can be valuable for:

- EA prerequisite 1: fundamental commissioning of energy management systems;
- EA credit 3: enhanced commissioning (2 points);
- EA credit 5: measurements and verification (3 points).

**NOTE:** Products are not reviewed or certified under LEED®. LEED® credit requirements cover the performance of materials in aggregate, not the performance of individual products or brands. For more information on LEED®, visit [www.usgbc.org](http://www.usgbc.org).

## 30RB - 30RQ TECHNICAL OVERVIEW

### COPPER/ALUMINIUM COILS (30RQ)

- Protective heat shrink sleeves around the distribution sections
- Coil heaters to prevent frost formation and help drain condensate during defrosting



### SIXTH GENERATION FLYING BIRD™ FIXED-SPEED FANS

- Exclusive Carrier design
- Fan blade design inspired by nature
- High efficiency version with AC motor technology



### SMARTVU™ CONTROL

- 9 languages available
- 4.3" user-friendly touch screen
- All main parameters displayed on one screen
- Direct access to the unit's technical drawings and the main service documents
- Very easy online monitoring
- Easy and secure access to unit parameters
- Optional BACnet, J-Bus or LON communication interfaces

### SMART ENERGY CONSUMPTION MONITORING

- Real time energy consumption estimation (kWh)
- Estimation of the supplied cooling/heating energy (kWh)
- Instantaneous and average energy efficiency values under real operating conditions
- Remote monitoring with "Connected service"



### NOVATION™ SECOND GENERATION MICRO CHANNEL HEAT EXCHANGERS (30RB)

- Increased reliability with new aluminium alloy
- Significantly reduces the refrigerant charge (-40% compared to Cu/Al coils)
- Improved thermal performance, improved efficiency and lower pressure drops compared to Cu/Al coils
- Enviro-Shield® coating for mildly corrosive environments
- Super Enviro-Shield® coating for highly corrosive environments (industrial or marine applications)
- Easy cleaning with high pressure air or water washer

### SCROLL COMPRESSORS



### REDUCED REFRIGERANT CHARGE



### HIGH-EFFICIENCY BRAZED PLATE HEAT EXCHANGER

- Latest generation asymmetrical type
- Low pressure drop



## 30RBP - 30RQP TECHNICAL OVERVIEW





## TECHNICAL INSIGHTS

### SmartVu™ control

The SmartVu™ control combines intelligence with operating simplicity. The control constantly monitors all machine parameters and precisely manages the operation of compressors, expansion devices, fans and the evaporator water pump for optimum energy efficiency.

The SmartVu™ control features advanced Ethernet-based communication technology (IP) and a user-friendly and intuitive user interface with 4.3-inch colour touch screen.

- Energy management configuration
  - Internal timer: Controls chiller on/off times and operation at a second setpoint
  - Setpoint offset based on the outdoor air temperature
  - Master/slave control of two chillers operating in parallel with runtime balancing and automatic changeover in case of a unit fault.
  - Innovative smart energy monitoring, providing users with smart data such as real-time electrical energy consumption and cooling capacity, and instantaneous and average energy efficiency values.
  - For further energy savings, the AquaSnap® can be monitored remotely by Carrier experts for energy consumption diagnosis and optimisation.
- Integrated features
  - Night mode: Capacity and fan speed limitation for reduced noise level
  - With hydraulic module: Water pressure display and water flow rate calculation.
- Advanced communication features
  - Easy, high-speed communication technology over Ethernet (IP) to a centralised building management system
  - Access to multiple unit parameters.
- Maintenance functions
  - F-Gas regulation leak check reminder alert
  - Maintenance alert can be configured to days, months or hours of operation
  - Storage of maintenance manual, wiring diagram and spare parts list
  - Display of trend curves for the main values
  - Management of a fault memory allowing a log of the last 50 incidents to be accessed, with operating readings taken when the fault occurs
  - Blackbox memory

- 4"3 SmartVu™ user interface



- Intuitive and user-friendly 4"3 inch touch screen interface
- Concise and clear information is available in local languages
- Complete menu, customised for different users (end user, service personnel or Carrier engineers).

### Remote management (standard)

Units with SmartVu™ control can be easily accessed from the internet, using a PC with an Ethernet connection. This makes remote control quick and easy and offers significant advantages for service operations.

The AquaSnap® is equipped with an RS485 serial port that offers multiple remote control, monitoring and diagnostic possibilities. Carrier offers a vast choice of control products, specially designed to control, manage and supervise the operation of an air conditioning system. Please consult your Carrier representative for more information.

The AquaSnap® also communicates with other centralised building management systems via optional communication gateways.

A connection terminal allows the AquaSnap® unit to be remotely controlled by wire:

- Start/stop: Opening of this contact will shut down the unit
- Dual setpoint: closing of this contact activates a second setpoint (e.g.: unoccupied mode).
- Demand limit: Closing of this contact limits the maximum chiller capacity to a predefined value.
- Operation indication: This volt-free contact indicates that the chiller is operating (refrigeration).
- Alarm indication: this volt-free contact indicates the presence of a major fault that has led to the shut-down of one or several refrigerant circuits.

## TECHNICAL INSIGHTS

### Energy management module (option)

The Energy Management Module offers extended remote control possibilities:

- Room temperature: enables the setpoint to be reset based on the indoor air temperature of the building (with Carrier thermostat).
- Setpoint reset: the cooling setpoint is reset based on a 4-20 mA signal.
- Demand limit: enables the maximum chiller power to be limited based on a 4-20 mA signal.
- Demand limit 1 and 2: closing of these contacts limits the maximum chiller power or current to two predefined values.
- User safety: this contact can be used for any customer safety loop; opening the contact generates a specific alarm.
- Ice storage end: when ice storage has finished, this input is used to return to the second setpoint (unoccupied mode).
- Time schedule override: closing of this contact cancels the effects of the time schedule.
- Out of service: this signal indicates that the chiller is completely out of service.
- Chiller capacity: this analogue output (0-10 V) gives an immediate indication of the chiller capacity.
- Alert indication: this volt-free contact indicates the need to carry out a maintenance operation or the presence of a minor fault.
- Boiler control: this on/off output controls an independent boiler to provide hot water.

## OPTIONS

Options	No.	Description	Advantages	30RB/RBP 170R-950R	30RQ/RQP 165R-1040R
Corrosion protection, traditional coils	3A	Fins made of pre-treated aluminium (polyurethane and epoxy)	Improved corrosion resistance, recommended for moderate marine and urban environments	No	165R-1040R
Low-temperature brine solution	6B	Low temperature chilled water production down to -8 °C with ethylene or propylene glycol	Covers specific applications such as ice storage and industrial processes	30RBP 170R-950R	No
High-pressure static fans	12	Unit equipped with high-pressure variable-speed static fans (maximum 200 Pa), each fan being equipped with a connection flange for connection to the ducting system.	Ducted fan discharge, optimised fan speed control, based on the operating conditions and system characteristics	30RBP 170R-950R	30RQP 165R-1040R
Very low noise level	15LS	Acoustic compressor enclosure and low-speed fans	Noise level reduction for sensitive sites	170R-950R	165R-1040R
EC fans	17	Unit equipped with EC fans	Improves the unit's energy efficiency	30RBP 170R-950R	30RQP 165R-1040R
Protection grilles	23	Metallic protection grilles	Coil protection against possible impact	170R-950R	165R-1040R
Soft starter per circuit	25E	Soft starter on each circuit	Economical solution for reduced start-up current	170R-950R	165R-1040R
Soft starter per compressor	25	Electronic starter on each compressor	Reduced start-up current	170R-410R	165R-400R / 620R-800R
Water exchanger frost protection	41	Electric heater on the water type heat exchanger and the water duct	Water type heat exchanger module frost protection for an outdoor air temperature between 0 °C and -20 °C	170R-950R	165R-1040R
Water manifold antifreeze protection	41D	Electric heater and insulation on the water collection vessel pipes	Water manifold antifreeze protection down to an outdoor temperature of -20 °C	No	30RQP 620R-1040R
Unit frost protection with Free Cooling Glycol Free option	41E	Electric resistance heater on water exchanger, and hydraulic module	Water exchanger and hydraulic module frost protection down to -20°C outside temperature	170R-950R	No
Exchanger and hydraulic module frost protection	42A	Electrical heaters on the water type heat exchanger, water pipes, hydraulic module and expansion tank	Water type heat exchanger and hydraulic module frost protection down to an outdoor air temperature of -20 °C	170R-950R	165R-1040R
Exchanger and hydraulic frost protection with buffer tank	42B	Electrical heater on the water type heat exchanger, water pipes, hydraulic module and optional expansion tank & buffer tank	Water type heat exchanger and hydraulic module frost protection down to an outdoor air temperature of -20 °C	170R-950R	165R-1040R
Partial heat recovery	49	Unit equipped with one desuperheater on each refrigerant circuit	Production of free high-temperature hot water simultaneously with chilled water production (or hot water for heat pump)	170R-950R	165R-1040R
Total heat recovery	50	Unit equipped with additional heat exchanger in series with the condenser coils.	Production of free hot water, adjustable on demand	30RBP 170R-950R	No
Master/slave operation	58	Unit equipped with supplementary water outlet temperature sensor kit (to be field installed) allowing master/slave operation of two units connected in parallel	Optimised operation of two units connected in parallel operation with runtime balancing	170R-950R	165R-520R
Compressor suction and discharge valves	92A	Shut-off valves on the common compressor suction and discharge pipes	Simplified maintenance. Possibility to store the refrigerant charge in the cooler or condenser side during servicing	170R-950R	165R-1040R
HP single-pump hydraulic module	116R	Single high-pressure water pump. (expansion tank with built-in safety hydraulic components available in option)	Quick and easy installation (plug & play)	170R-550R	165R-520R
HP dual-pump hydraulic module	116S	Dual high-pressure fixed-speed pump. (expansion tank with built-in safety hydraulic components available in option)	Quick and easy installation (plug & play)	170R-550R	165R-520R

## OPTIONS

Options	No.	Description	Advantages	30RB/RBP 170R-950R	30RQ/RQP 165R-1040R
LP single-pump hydraulic module	116T	Single low-pressure fixed-speed pump.(expansion tank with built-in safety hydraulic components available in option)	Quick and easy installation (plug & play)	170R-550R	165R-520R
LP dual-pump hydraulic module	116U	Dual low-pressure water pump Fixed-speed pump, (expansion tank with built-in safety hydraulic components available in option)	Quick and easy installation (plug & play)	170R-550R	165R-520R
Variable-speed single HP pump	116V	Single high-pressure water pump with variable speed drive (VSD), electronic water flow control, pressure transducers. Multiple possibilities of water flow control. (expansion tank not included)	Easy and fast installation (plug & play), significant pumping energy cost savings (up totwo-thirds), tighter water flow control, improved sytem reliability	170R-950R	165R-1040R
Variable-speed dual high-pressure pump.	116W	Dual high-pressure water pump with variable speed drive (VSD), pressure transducers. Multiple possibilities of water flow control (expansion tank with built-in safety hydraulic components available in option)	Easy and fast installation (plug & play), significant pumping energy cost savings (up to two-thirds), tighter water flow control, improved sytem reliability	170R-950R	165R-1040R
High energy efficiency underfloor heating/cooling application	119C	Optimisation of the refrigerant and control circuit for the underfloor heating/cooling system application	Improvement of performances and reduction of energy costs for the underfloor heating/cooling application	No	165R-1040R
Lon communication gateway	148D	Two-directional communication board complying with Lon Talk protocol	Connects the unit by communication BUS to a centralised building management system	170R-950R	165R-1040R
ModBus over IP and RS485 communication gateway	149B	Two-directional high-speed communication using the ModBus over Ethernet network (IP) protocol	Easy, quick connection via Ethernet line to a building technical management system. Allows access to several unit parameters.	170R-950R	165R-1040R
Bacnet over IP	149	Two-directional high-speed communication using BACnet protocol over Ethernet network (IP)	Easy and high-speed connection by Ethernet line to a BMS. Allows access to multiple unit parameters	170R-950R	165R-1040R
Energy management module	156	EMM Control board with additional inputs/outputs. See Energy Management Module section	Extended remote control capabilities (setpoint reset, ice storage end, demand limits, boiler on/off command...)	170R-950R	165R-1040R
Contact for refrigerant leak detection	159	0-10 V signal to report any refrigerant leakage in the unit directly (the leak detector itself must be supplied by the customer)	Immediate customer notification of refrigerant losses to the atmosphere, allowing timely corrective actions	170R-950R	165R-1040R
Phase controller	159B	Phase controller on the power supply	Reinforced protection of the compressors by monitoring rotation, the absence and asymmetry of the phases, and the over- or under-voltage of the electricity network	170R-950R	165R-1040R
Compliance with Russian regulations	199	EAC certification	Compliance with Russian regulations	170R-950R	165R-1040R
Coil defrost resistance heaters	252	Electric heaters under the coils and the condensate pans	Prevents frost formation on the coils; compulsory in heating mode if the outdoor temperature is below 0 °C	No	165R-1040R
Insulation of the evaporator inlet/ outlet refrigerant lines	256	Thermal insulation of the evaporator inlet/outlet refrigerant lines, with UV-resistant flexible connection and insulation	Prevents condensation on the evaporator inlet/outlet refrigerant lines	170R-950R	165R-1040R

## OPTIONS

Options	No.	Description	Advantages	30RB/RBP 170R-950R	30RQ/RQP 165R-1040R
Enviro-Shield anti-corrosion protection®	262	Coating applied using a conversion process which modifies the surface of the aluminium producing a coating that is integral to the coil. Complete immersion in a bath to ensure 100% coverage. Minimal heat transfer variation, tested to withstand more than 4000 hours of salt spray as per ASTM B117	Improved corrosion resistance, recommended for use in moderately corrosive environments	170R-950R	No
Anticorrosion coating on Free Cooling option coils	262ABC	Same anticorrosion treatment as on MCHE condenser coils	Improved corrosion resistance, recommended for use in extremely corrosive environments	170R-950R	No
Super Enviro-Shield anti-corrosion protection®	263	Extremely durable and flexible epoxy polymer coating applied by electro coating process, final UV protective topcoat. Minimal heat transfer variation, tested to withstand more than 6000 hours of constant neutral salt spray as per ASTM B117, improved impact resistance as per ASTM D2794	Improved corrosion resistance, recommended for use in extremely corrosive environments	170R-950R	No
Welded evaporator connection kit	266	Victaulic piping connections with welded joints	Easy installation	170R-950R	165R-1040R
Compressor enclosure	279a	Compressor with enclosure	Improved aesthetics, compressor protection against external elements (dust, sand, water...)	170R-950R	165R-1040R
EMC class. C2, as per EN 61800-3	282	Additional RFI filters on the unit power line	Reduces electromagnetic interferences in compliance with the emissions level required in category C2 to enable it to be used in the first environment ("residential environment")	170R-950R	165R-1040R
230 V electrical plug	284	230 VAC power source provided with plug socket and transformer (180 VA, 0.8 A)	Enables connection of a laptop or an electrical device during system start-up or maintenance	170R-950R	165R-1040R
Expansion tank	293	6-bar expansion tank built into the hydraulic module (requires hydraulic module option)	Easy and fast installation (plug & play), & protection of closed water systems from excessive pressure	170R-950R	165R-1040R
Electric energy meter	294	Electric energy meter. Display of energy consumption, instantaneous (U, V, I) and cumulative (kWh), on the machine interface, data available on the communication bus	Permits the acquisition and monitoring (remotely via the CMS/BMS) of the energy used.	170R-950R	165R-1040R
Ultra fast capacity recovery	295+	Built-in capacity module to allow an ultra-rapid restart whilst maintaining the unit's reliability.	Full capacity recovery in less than 2.5 minutes after a power failure lasting less than ten minutes. Matches requirements of typical critical mission applications. (process, data centres)	30RBP 170R-950R	No
Screwed water connection sleeves for desuperheater	303	DSH connections with screw connection sleeves	Easy to install. Allows unit connection to a screw connector	170R-950R	165R-1040R
Welded connection sleeve for desuperheater	304	DSH inlet/outlet welded connection sleeves	Easy installation	170R-950R	165R-1040R
Free cooling (total)	305A	Free cooling hydraulic coils on the two refrigerant circuits	Energy savings for applications which require cooling all year round (e.g.: industrial processes, data centres)	30RBP 170R-950R	No
Free cooling (partial)	305B	Free cooling hydraulic coils on a refrigerant circuit	Energy savings for applications with reduced demand for cooling in the winter (e.g. office space with computer room, meeting rooms)	30RBP 170R-950R	No
Free Cooling Glycol-Free (Total)	305C	Free cooling hydraulic coils on both refrigerant circuits and decoupling exchanger.	Energy savings for applications which require cooling all year round (e.g.: industrial processes, data centres, etc.) Glycol-free operation	30RBP 170R-950R	No
Water buffer tank module	307	Built-in water buffer tank module	Avoids short cycle on compressors and ensures stable water in the loop	170R-950R	165R-1040R
Free cooling dry cooler management	313	Control & connections to a Free Cooling Dry cooler 09PE or 09VE fitted with option FC control box	Easy system management, control capabilities extended to a dry cooler used in Free Cooling mode	170R-950R	No



## OPTIONS

Options	No.	Description	Advantages	30RB/RBP 170R-950R	30RQ/RQP 165R-1040R
Compliance with UAE regulations	318	Additional label on the unit with input power, current and EER under rated conditions in accordance with AHRI 550/590	Compliance with ESMA standard UAE 5010-5:2016.	170R-950R	No
Compliance with Qatar regulations	319	Specific name plate on the unit with 415 V +/-6% power supply	Compliance with KAHRAMAA regulations in Qatar	170R-950R	No
Water manifold	325A	Pipe system ensuring a single hydraulic connection point	Easy installation	No	620R-1040R
Installation or application process outside Europe	326	Specific management of option compatibility	Permits non-standard option compatibility for HVAC application in the EU	30RB 170R-380R 30RBP 170R-950R	No
Compliance with Moroccan regulations	327	Specific regulatory documentation	Compliance with Moroccan regulations	170R-950R	165R-1040R
Delivered wrapped in plastic film	331	Unit wrapped in a plastic cover and strapped onto a wooden pallet.	Protects against dust and external soiling of the unit during storage and transport.	170R-950R	165R-1040R



## FREE COOLING SYSTEM (OPTION 305A – 305B – 305C)

Reducing operating costs and protecting the environment have become the key concerns, both for air conditioning applications, and for industrial processes and cooling data centres.

The free cooling option allows significant energy savings to be made in all applications that require cooling throughout the year, particularly when used in colder climates. In these regions, free cooling can be used to fulfil a large proportion of the cooling requirements both economically and in a way that respects the environment.

In free cooling mode, the compressors are stopped, and only the fans are in operation. The SmartVu™ control automatically switches from compressor cooling mode to free cooling mode depending on the chiller heat load and the temperature differential between the chilled water outlet and the ambient air.

**Important: To optimise cooler performance, you are recommended to use the leaving water temperature setpoint offset function.**

### Operating principle

The unit's SmartVu™ control maximises the use of the free cooling based on the needs of the application and the climate conditions. Once the chilled water/ambient air temperature differential exceeds the threshold value by 1K (2K on the Glycol Free version), the SmartVu™ control activates free cooling and adjusts the air flow rate to optimise the unit's energy performance. If the operating conditions permit the free cooling to operate on its own to meet the requirements, the compressors are stopped. Two motorised valves direct the chilled water to the free cooling coils.

### Three operating modes are possible:

#### Summer (warm weather season): Mechanical cooling mode

The liquid chiller meets the needs traditionally using the refrigerant circuit. The fluid bypasses the free cooling coils and is cooled by the evaporator.

#### Mid-season: Combination mode

It is possible to operate in combination free cooling and mechanical cooling mode. This helps optimise free cooling operations while covering the system's cooling requirements. The fluid is pre-cooled by the free cooling coils positioned in series with the refrigerant circuit evaporator which finalises cooling of the fluid.

#### Winter (cold weather season): Free cooling mode

Depending on the capacity requested and the setpoint, all of the requirements may be fulfilled by the free cooling in this operating mode without the fans running, thereby ensuring optimum energy efficiency.

### Adaptations to requirements

Depending on the requirements of the user, the AquaSnap free cooling is available with 3 performance levels:

- 305A total hydraulic free cooling on the 2 circuits, specifically designed for installations which have major cooling requirements all year round (industrial processes, data centres)
- 305C, Total Hydraulic Free-Cooling, Glycol-Free version, enables the use of pure water in the cooling circuit.
- 305B partial hydraulic free cooling on 1 circuit, designed for installations which have limited cooling requirements during the winter (offices, hospitals, etc.)

### Advantages of the built-in free cooling system

- The free cooling function is independent of the refrigerant circuit, which increases reliability and facilitates maintenance compared to free cooling built into the refrigerant circuit (DX FC).
- The Hydraulic Free Cooling design is intended to expand the scope of application compared to the Free Cooling refrigerant concept (DX FC) by enabling Free Cooling mode to be activated by a higher outdoor temperature, thereby allowing for greater energy savings.
- The built-in Hydraulic Free Cooling version developed based on the AquaSnap® range allows all of the advantages of a free cooling solution to be combined with the compact design of the base units.

### Advantage of the Free Cooling Glycol-Free system

In applications or countries in which the use of glycol is strictly regulated or banned, the Free Cooling Glycol-Free option is equipped with a separation heat exchanger, and only the circuit inside the unit contains glycol, while the user circuit contains pure water.

This solution with an intermediate exchanger shifts the Free Cooling mode activation thresholds by a few degrees, and the heat exchangers selected by Carrier help to minimise this shift.



## FREE COOLING SYSTEM (OPTION 305A – 305B)

### Physical properties of 30RBP units with the Free Cooling option

30RBP			170R	190R	210R	230R	270R	310R	340R	380R	410R	450R		
<b>Cooling</b>														
Standard unit Full load performances*	CA1	Maximum rated capacity	kW		181	198	220	239	288	328	366	401	440	475
		EER	kW/kW		3,28	3,46	3,31	3,25	3,12	3,23	3,16	3,21	3,16	3,22
<b>FREE COOLING</b>														
Total free cooling option (305A)	CFC1	Maximum rated capacity	kW		182	243	243	243	243	303	303	364	364	425
		Free cooling EER	kW/kW		25,86	25,43	25,43	25,43	25,76	25,76	25,94	25,55	25,71	26,07
		Rate of coverage by free cooling	%		101%	122%	110%	102%	84%	93%	83%	91%	83%	89%
		Outdoor temperature for 100% coverage by free cooling	°C		0,1	2,3	1,2	0,2	-2,3	-1,0	-2,6	-1,3	-2,6	-1,5
		Pressure drops	kPa		94	112	112	112	102	107	101	117	112	103
		Sound power <sup>(1)</sup>	dB(A)		88,0	89,0	89,0	89,0	89,0	90,0	90,0	90,5	91,0	91,0
		Sound pressure at 10 m <sup>(2)</sup>	dB(A)		69,0	70,5	70,5	70,5	70,5	70,5	70,5	71,0	71,5	71,0
Partial free cooling option (305B)	CFC1	Maximum rated capacity	kW		121	121	121	121	121	121	121	145	145	182
		Free cooling EER	kW/kW		25,78	25,78	25,78	25,78	25,87	25,97	26,00	19,15	19,14	26,46
		Rate of coverage by free cooling	%		67%	61%	55%	51%	42%	37%	33%	36%	33%	38%
		Pressure drops	kPa		80	80	80	80	77	75	74	81	79	75
		Sound power <sup>(1)</sup>	dB(A)		86,0	86,0	86,0	86,0	86,0	86,0	86,0	87,5	88,0	87,5
		Sound pressure at 10 m <sup>(2)</sup>	dB(A)		67,5	67,5	67,5	67,5	67,5	66,5	66,5	68,0	68,5	67,5
Unit + option 15LS <sup>(3)</sup> Full load performances*	CA1	Maximum rated capacity	kW		171	189	208	226	270	309	343	377	413	447
		EER	kW/kW		3,06	3,29	3,08	3,03	2,82	2,96	2,85	2,94	2,86	2,94
<b>FREE COOLING</b>														
Total free cooling option (305A)	CFC1	Maximum rated capacity	kW		148	197	197	197	197	247	247	296	296	345
		Free cooling EER	kW/kW		39,92	39,76	39,76	39,76	40,28	40,58	41,01	40,14	40,52	41,39
		Rate of coverage by free cooling	%		87%	104%	95%	87%	73%	80%	72%	79%	72%	77%
		Outdoor temperature for 100% coverage by free cooling	°C		-2,0	0,5	-0,8	-1,9	-4,8	-3,3	-5,1	-3,6	-5,1	-3,8
		Pressure drops	kPa		65	77	77	77	71	73	70	80	77	71
		Sound power <sup>(1)</sup>	dB(A)		79,5	80,5	80,5	80,5	81,0	82,0	82,0	82,0	82,5	82,5
		Sound pressure at 10 m <sup>(2)</sup>	dB(A)		60,5	62,0	62,0	62,0	62,5	63,0	63,0	62,5	63,0	62,5
Partial free cooling option (305B)	CFC1	Maximum rated capacity	kW		98	98	98	98	99	99	99	118	118	148
		Free cooling EER	kW/kW		42,39	42,39	42,39	42,39	42,73	43,05	43,17	30,35	30,48	43,20
		Rate of coverage by free cooling	%		58%	52%	47%	44%	37%	32%	29%	31%	29%	33%
		Pressure drops	kPa		55	55	55	55	54	52	51	56	55	52
		Sound power <sup>(1)</sup>	dB(A)		77,5	77,5	77,5	77,5	78,0	78,0	78,0	79,0	79,5	79,0
		Sound pressure at 10 m <sup>(2)</sup>	dB(A)		59,0	59,0	59,0	59,0	59,5	59,0	59,5	60,0	59,0	

\* In accordance with EN14511-3:2022.

CA1 Cooling mode conditions: evaporator water inlet/outlet temperature 17 °C/10 °C, outdoor air temperature at 35 °C, 30% Mono-Ethylene-Glycol, evaporator fouling factor 0 m<sup>2</sup>. k/W

CFC1 Free cooling mode conditions: evaporator water inlet/outlet temperature 17 °C/10 °C, outdoor air temperature at 0 °C, 30% Mono-Ethylene-Glycol, evaporator fouling factor 0 m<sup>2</sup>. k/W

(1) In dB ref=10<sup>-12</sup> W, (A) weighting. Declared dual-number noise emission value in accordance with ISO 4871 with an uncertainty of +/-3 dB(A). Measured in accordance with ISO 9614-1 and certified by Eurovent.

(2) In dB ref 20 µPa, (A) weighting. Declared dual-number noise emission value in accordance with ISO 4871 with an uncertainty of +/-3 dB(A). For information, calculated from the sound power Lw(A).

(3) Options: 15LS = Very low noise level, 116V = Variable speed high pressure single-pump hydraulic module,



**FREE COOLING SYSTEM (OPTION 305A – 305B)**

30RBP		170R	190R	210R	230R	270R	310R	340R	380R	410R	450R
<b>Total Free Cooling - Option 305A</b>											
<b>Free cooling coil</b>		All-aluminium micro-channel coils (MCHE)									
Quantity		3	4	4	4	4	5	5	6	6	7
<b>Hydraulic connection</b>											
Connection		in	3"	3"	3"	3"	3"	4"	4"	4"	4"
External diameter		mm	88,9	88,9	88,9	88,9	88,9	114,3	114,3	114,3	114,3
Additional water volume		l	60	72	72	72	72	113	113	126	126
<b>Weight<sup>(4)</sup></b>											
Additional weight (without water)		kg	225	266	266	266	266	357	359	395	397
Additional weight (during operation)		kg	287	341	341	341	341	475	477	526	528
<b>Operation</b>											
Max. operating pressure, water side		bar	6	6	6	6	6	6	6	6	6
<b>Partial Free Cooling - Option 305B</b>											
<b>Free cooling coil</b>		All-aluminium micro-channel coils (MCHE)									
Quantity		2	2	2	2	2	2	2	3	3	3
<b>Hydraulic connection</b>											
Connection		in	3"	3"	3"	3"	3"	4"	4"	4"	4"
External diameter		mm	88,9	88,9	88,9	88,9	88,9	114,3	114,3	114,3	114,3
Additional water volume		l	48	48	48	48	48	58	58	75	75
<b>Weight<sup>(4)</sup></b>											
Additional weight (without water)		kg	178	178	178	178	179	210	212	248	250
Additional weight (during operation)		kg	227	227	227	227	228	271	273	326	328
<b>Operation</b>											
Max. operating pressure, water side		bar	6	6	6	6	6	6	6	6	6

(4) Values are guidelines only. Refer to the unit name plate.



## FREE COOLING SYSTEM (OPTION 305A – 305B)

30RBP			480R	550R	610R	670R	720R	770R	800R	870R	950R	
<b>Cooling</b>												
<b>Standard unit</b> Full load performances*	CA1	Maximum rated capacity	kW	512	585	652	718	767	827	852	932	994
		EER	kW/kW	3,16	3,15	3,23	3,22	3,12	3,14	3,10	3,06	2,96
<b>FREE COOLING</b>												
Total free cooling option (305A)	CFC1	Maximum rated capacity	kW	425	485	546	607	607	667	667	728	728
		Free cooling EER	kW/kW	26,12	25,96	25,99	25,77	25,77	25,65	25,65	25,41	25,41
		Rate of coverage by free cooling	%	83%	83%	84%	84%	79%	81%	78%	78%	73%
		Outdoor temperature for 100% coverage by free cooling	°C	-2,6	-2,6	-2,4	-2,3	-3,3	-3,0	-3,5	-3,5	-4,6
		Pressure drops	kPa	102	110	111	120	120	126	126	136	136
		Sound power <sup>(1)</sup>	dB(A)	91,0	91,5	92,5	93,0	93,0	93,0	93,0	93,5	94,0
		Sound pressure at 10 m <sup>(2)</sup>	dB(A)	71,0	71,5	72,0	72,5	72,5	72,0	72,0	72,5	73,0
Partial free cooling option (305B)	CFC1	Maximum rated capacity	kW	182	242	204	262	262	303	303	364	364
		Free cooling EER	kW/kW	26,46	26,58	20,36	20,91	20,91	26,66	26,66	26,57	26,57
		Pressure drops	kPa	75	79	77	82	82	80	80	86	86
		Sound power <sup>(1)</sup>	dB(A)	87,5	88,5	89,0	90,0	90,0	89,5	89,5	90,5	91,0
		Sound pressure at 10 m <sup>(2)</sup>	dB(A)	67,5	68,5	68,5	69,5	69,5	68,5	68,5	69,5	70,0
<b>Unit + option 15LS<sup>(3)</sup></b> Full load performances*	CA1	Maximum rated capacity	kW	481	549	613	677	719	777	798	873	925
		EER	kW/kW	2,85	2,85	2,94	2,94	2,82	2,84	2,79	2,76	2,63
<b>FREE COOLING</b>												
Total free cooling option (305A)	CFC1	Maximum rated capacity	kW	345	395	444	493	493	543	543	592	592
		Free cooling EER	kW/kW	41,49	41,14	41,23	40,73	40,73	40,47	40,47	39,92	39,92
		Rate of coverage by free cooling	%	72%	72%	72%	73%	69%	70%	68%	68%	64%
		Outdoor temperature for 100% coverage by free cooling	°C	-5,1	-5,1	-5,0	-4,8	-5,9	-5,6	-6,1	-6,2	-7,3
		Pressure drops	kPa	70	75	76	82	82	86	86	93	93
		Sound power <sup>(1)</sup>	dB(A)	83,0	83,5	85,0	85,0	85,0	85,5	84,5	85,5	86,0
		Sound pressure at 10 m <sup>(2)</sup>	dB(A)	63,0	63,5	64,0	64,5	64,5	64,5	63,5	64,5	65,0
Partial free cooling option (305B)	CFC1	Maximum rated capacity	kW	148	197	166	213	213	247	247	296	296
		Free cooling EER	kW/kW	43,24	43,63	32,85	34,02	34,02	44,19	44,19	44,26	44,26
		Rate of coverage by free cooling	%	31%	36%	27%	31%	30%	32%	31%	34%	32%
		Pressure drops	kPa	52	55	53	56	56	56	56	59	59
		Sound power <sup>(1)</sup>	dB(A)	79,5	80,5	81,0	82,0	82,0	82,0	81,0	82,5	83,0
		Sound pressure at 10 m <sup>(2)</sup>	dB(A)	59,5	60,5	60,5	61,5	61,5	61,0	60,0	61,5	62,0

\* In accordance with EN14511-3:2022.

CA1 Cooling mode conditions: evaporator water inlet/outlet temperature 17 °C/10 °C, outdoor air temperature at 35 °C, 30% Mono-Ethylene-Glycol, evaporator fouling factor 0 m<sup>2</sup>. k/W

CFC1 Free cooling mode conditions: evaporator water inlet/outlet temperature 17 °C/10 °C, outdoor air temperature at 0 °C, 30% Mono-Ethylene-Glycol, evaporator fouling factor 0 m<sup>2</sup>. k/W

(1) In dB ref=10<sup>-12</sup> W, (A) weighting. Declared dual-number noise emission value in accordance with ISO 4871 with an uncertainty of +/-3 dB(A). Measured in accordance with ISO 9614-1 and certified by Eurovent.

(2) In dB ref 20 µPa, (A) weighting. Declared dual-number noise emission value in accordance with ISO 4871 with an uncertainty of +/-3 dB(A). For information, calculated from the sound power Lw(A).

(3) Options: 15LS = Very low noise level, 116V = Variable speed high pressure single-pump hydraulic module.





**FREE COOLING SYSTEM (OPTION 305A – 305B)**

30RBP		480R	550R	610R	670R	720R	770R	800R	870R	950R	
<b>Total Free Cooling - Option 305A</b>											
<b>Free cooling coil</b>		All-aluminium micro-channel coils (MCHE)									
Quantity		7	8	9	10	10	11	11	12	12	
<b>Hydraulic connection</b>											
Connection		in	4"	4"	5"	5"	5"	5"	5"	5"	
External diameter		mm	114,3	114,3	139,7	139,7	139,7	139,7	139,7	139,7	
Additional water volume		l	200	213	298	310	310	351	351	364	
<b>Weight<sup>(4)</sup></b>											
Additional weight (without water)		kg	515	556	662	700	700	814	814	851	
Additional weight (during operation)		kg	724	778	972	1023	1023	1180	1180	1230	
<b>Operation</b>											
Max. operating pressure, water side		bar	6	6	6	6	6	6	6	6	
<b>Partial Free Cooling - Option 305B</b>											
<b>Free cooling coil</b>		All-aluminium micro-channel coils (MCHE)									
Quantity		3	4	4	5	5	5	5	6	6	
<b>Hydraulic connection</b>											
Connection		in	4"	4"	5"	5"	5"	5"	5"	5"	
External diameter		mm	114,3	114,3	139,7	139,7	139,7	139,7	139,7	139,7	
Additional water volume		l	101	120	186	198	198	205	205	224	
<b>Weight<sup>(4)</sup></b>											
Additional weight (without water)		kg	305	346	406	443	443	499	499	536	
Additional weight (during operation)		kg	410	471	600	650	650	713	713	770	
<b>Operation</b>											
Max. operating pressure, water side		bar	6	6	6	6	6	6	6	6	

(4) Values are guidelines only. Refer to the unit name plate.



## GLYCOL-FREE FREE COOLING SYSTEM (OPTION 305C)

30RBP			170R	190R	210R	230R	270R	310R	340R	380R	410R	450R	
<b>Cooling</b>													
Standard unit Full load performances*	CA2	Maximum rated capacity	kW	226	247	277	298	364	409	461	502	553	598
		EER	kW/kW	3,65	3,87	3,64	3,60	3,35	3,52	3,39	3,49	3,38	3,50
<b>FREE COOLING</b>													
Glycol-free total free cooling option (305C)	CFC2	Maximum rated capacity	kW	264,10	341,93	341,93	341,93	341,92	440,37	440,17	516,21	516,24	617,18
		Free cooling EER	kW/kW	25,76	24,97	24,97	24,97	25,64	24,85	25,22	24,67	24,99	24,89
		Rate of coverage by free cooling	%	117%	139%	123%	115%	94%	108%	96%	103%	93%	103%
		Outdoor temperature for 100% coverage by free cooling	°C	3,30	6,40	4,40	3,00	-1,50	1,60	-1,00	0,70	-1,60	0,70
		Pressure drops	kPa	87,25	141,24	141,24	141,24	121,60	113,45	102,00	140,77	130,72	117,53
		Sound power <sup>(1)</sup>	dB(A)	88,0	89,0	89,0	89,0	89,0	90,0	90,0	90,5	91,0	91,0
		Sound pressure at 10 m <sup>(2)</sup>	dB(A)	69,5	70,5	70,5	70,5	70,5	70,5	70,5	71,0	71,5	71,0
Unit + option 15LS <sup>(3)</sup> Full load performances*	CA2	Maximum rated capacity	kW	205	227	253	270	328	370	415	454	500	541
		EER	kW/kW	3,12	3,43	3,13	3,08	2,76	2,96	2,79	2,92	2,78	2,92
<b>FREE COOLING</b>													
Glycol-free total free cooling option (305C)	CFC2	Maximum rated capacity	kW	215,64	281,76	281,76	281,76	281,73	359,09	358,84	423,72	423,78	502,60
		Free cooling EER	kW/kW	27,61	28,14	28,14	28,14	28,97	26,44	26,84	27,21	27,58	26,44
		Rate of coverage by free cooling	%	105%	124%	111%	104%	86%	97%	86%	93%	85%	93%
		Outdoor temperature for 100% coverage by free cooling	°C	1,10	4,50	2,30	0,90	-3,90	-0,70	-3,60	-1,70	-4,20	-1,70
		Pressure drops	kPa	59,79	98,40	98,40	98,40	84,59	77,22	69,28	96,87	89,86	79,66
		Sound power <sup>(1)</sup>	dB(A)	80,0	81,0	81,0	81,0	81,5	82,5	82,5	82,5	83,0	83,0
		Sound pressure at 10 m <sup>(2)</sup>	dB(A)	61,0	62,5	62,5	62,5	63,0	63,0	63,0	62,5	63,0	63,0
<b>Total glycol-free free cooling - Option 305C</b>													
<b>Free cooling coil</b>													
Quantity	All-aluminium micro-channel coils (MCHE)												
	3	4	4	4	4	5	5	6	6	7			
<b>Hydraulic connection</b>													
Connection	in	3"	3"	3"	3"	3"	3"	3"	3"	3"	3"	4"	
External diameter	mm	88,9	88,9	88,9	88,9	88,9	88,9	88,9	88,9	88,9	88,9	114,3	
Additional water volume	l	51	51	51	51	51	82	82	80	80	106		
<b>Dimensions</b>													
Additional length	mm	1194	1194	1194	1194	1194	1194	1194	1194	1194	1194	1194	
<b>Weight<sup>(4)</sup></b>													
Additional weight (without water)	kg	867	921	921	922	926	1105	1115	1161	1169	1427		
Additional weight (during operation)	kg	918	973	973	973	977	1187	1197	1241	1248	1533		
<b>Operation</b>													
Max. operating pressure, water side	bar	6	6	6	6	6	6	6	6	6	6	6	

\* In accordance with EN14511-3:2022.

CA2 Cooling mode conditions: evaporator water inlet/outlet temperature 26°C/20°C, outdoor air temperature at 35 °C, evaporator fouling factor 0 m<sup>2</sup>. kW

CFC2 Free cooling mode conditions: evaporator water inlet/outlet temperature 26°C/20°C, outdoor air temperature at 0 °C, evaporator fouling factor 0 m<sup>2</sup>. kW

(1) In dB ref=10<sup>-12</sup> W, (A) weighting. Declared dual-number noise emission value in accordance with ISO 4871 with an uncertainty of +/-3 dB(A). Measured in accordance with ISO 9614-1 and certified by Eurovent.

(2) In dB ref 20 µPa, (A) weighting. Declared dual-number noise emission value in accordance with ISO 4871 with an uncertainty of +/-3 dB(A). For information, calculated from the sound power L<sub>w</sub>(A).

(3) Options: 15LS = Very low noise level, 116V ,

(4) Values are guidelines only. Refer to the unit name plate.

**GLYCOL-FREE FREE COOLING SYSTEM (OPTION 305C)**

30RBP		480R	550R	610R	670R	720R	770R	800R	870R	950R		
<b>Cooling</b>												
<b>Standard unit</b>	CA2	Maximum rated capacity	kW	646	738	798	883	935	1013	1040	1136	1204
		Full load performances*	EER	kW/kW	3,39	3,38	3,40	3,41	3,25	3,28	3,22	3,16
<b>FREE COOLING</b>												
Glycol-free total free cooling option CFC2 (305C)		Maximum rated capacity	kW	617,18	694,77	789,36	866,14	866,14	968,24	968,24	1046,27	1046,27
		Free cooling EER	kW/kW	24,97	24,81	24,22	24,06	24,06	23,05	23,05	22,90	22,90
		Rate of coverage by free cooling	%	96%	94%	99%	98%	93%	96%	93%	92%	87%
		Outdoor temperature for 100% coverage by free cooling	°C	-1,00	-1,40	-0,20	-0,40	-1,80	-1,00	-1,70	-1,90	-3,40
		Pressure drops	kPa	114,76	138,86	122,90	146,49	146,49	148,78	148,78	172,42	172,42
		Sound power <sup>(1)</sup>	dB(A)	91,0	92,0	93,0	93,5	93,5	93,5	93,5	93,5	94,0
		Sound pressure at 10 m <sup>(2)</sup>	dB(A)	71,0	71,5	72,0	72,5	72,5	72,0	72,0	72,5	73,0
<b>Unit + option 15LS<sup>(3)</sup></b>	CA2	Maximum rated capacity	kW	582	666	719	797	840	826	924	850	900
		Full load performances*	EER	kW/kW	2,79	2,78	2,84	2,85	2,69	3,06	2,69	3,28
<b>FREE COOLING</b>												
Glycol-free total free cooling option CFC2 (305C)		Maximum rated capacity	kW	502,61	568,29	643,32	708,58	708,58	787,74	787,74	853,58	853,58
		Free cooling EER	kW/kW	26,54	27,09	25,39	25,81	25,81	23,73	23,73	24,01	24,01
		Rate of coverage by free cooling	%	86%	85%	89%	89%	84%	95%	85%	100%	95%
		Outdoor temperature for 100% coverage by free cooling	°C	-3,60	-4,00	-2,70	-2,90	-4,30	-1,10	-3,90	0,10	-1,20
		Pressure drops	kPa	77,75	94,79	83,48	100,21	100,21	100,52	100,52	117,09	117,09
		Sound power <sup>(1)</sup>	dB(A)	83,5	84,0	85,5	86,0	86,0	87,0	86,0	87,0	87,5
		Sound pressure at 10 m <sup>(2)</sup>	dB(A)	63,5	64,0	65,0	65,5	65,5	66,0	65,0	66,0	66,5
<b>Total glycol-free free cooling - Option 305C</b>												
<b>Free cooling coil</b>												
All-aluminium micro-channel coils (MCHE)												
Quantity		7	8	9	10	10	11	11	12	12		
<b>Hydraulic connection</b>												
Connection	in	4"	4"	5"	5"	5"	5"	5"	5"	5"		
External diameter	mm	114,3	114,3	139,7	139,7	139,7	139,7	139,7	139,7	139,7		
Additional water volume	l	106	104	157	157	157	199	199	199	199		
<b>Dimensions</b>												
Additional length	mm	1194	1194	1194	1194	1194	1194	1194	1194	1194		
<b>Weight<sup>(4)</sup></b>												
Additional weight (without water)	kg	1430	1488	1750	1797	1797	2018	2018	2070	2070		
Additional weight (during operation)	kg	1536	1592	1907	1954	1954	2218	2218	2269	2269		
<b>Operation</b>												
Max. operating pressure, water side	bar	6	6	6	6	6	6	6	6	6		

\* In accordance with EN14511-3:2022.  
 CA2 Cooling mode conditions: evaporator water inlet/outlet temperature 26°C/20°C, outdoor air temperature at 35 °C, evaporator fouling factor 0 m<sup>2</sup>. kW  
 CFC2 Free cooling mode conditions: evaporator water inlet/outlet temperature 26°C/20°C, outdoor air temperature at 0 °C, evaporator fouling factor 0 m<sup>2</sup>. kW  
 (1) In dB ref=10<sup>-12</sup> W, (A) weighting. Declared dual-number noise emission value in accordance with ISO 4871 with an uncertainty of +/-3 dB(A). Measured in accordance with ISO 9614-1 and certified by Eurovent.  
 (2) In dB ref 20 µPa, (A) weighting. Declared dual-number noise emission value in accordance with ISO 4871 with an uncertainty of +/-3 dB(A). For information, calculated from the sound power Lw(A).  
 (3) Options: 15LS = Very low noise level, 116V ,  
 (4) Values are guidelines only. Refer to the unit name plate.

PRESENTATION  
COOLING  
HEATING  
AIR TREATMENT  
CONTROLS



## FREE COOLING SYSTEM (OPTION 305A – 305B – 305C)

### Operating limits

#### 30RBP 170R-950R units

Water-cooled heat exchanger		Minimum	Maximum
Water inlet temperature at start-up	°C	8	40
Water outlet temperature during operation	°C	5	20
Air-cooled exchanger		Minimum	Maximum
Outdoor ambient operating temperature			
30RBP units - Full load	°C	-20	47
30RBP units - Part load	°C	-20	52 <sup>(1)</sup>

(1) Part load operation permitted above an outdoor air temperature of 47 °C. Contact the manufacturer to select a unit using the Carrier electronic catalogue.

All the free cooling units must be protected against freezing with 30% ethylene glycol in the cooling loop circuit (recommended value).

PHYSICAL DATA, SIZES 170R TO 380R

30RB		170R	190R	210R	230R	270R	310R	340R	380R	
<b>Cooling</b>										
<b>Standard unit</b>	Nominal capacity	kW	172	188	207	227	270	311	346	380
	Full load performances* CA1	EER	kW/kW	3,20	3,31	3,17	3,17	3,03	3,15	3,09
Seasonal energy efficiency**	<b>SEER<sub>12/7°C</sub> Comfort low temp.</b>	<b>kWh/kWh</b>	<b>4,28</b>	<b>4,35</b>	<b>4,28</b>	<b>4,24</b>	<b>4,26</b>	<b>4,43</b>	<b>4,44</b>	<b>4,25</b>
	$\eta_s$ cool <sub>12/7°C</sub>	%	<b>168</b>	<b>171</b>	<b>168</b>	<b>167</b>	<b>167</b>	<b>174</b>	<b>175</b>	<b>167</b>
	<b>SEER<sub>23/18°C</sub> Comfort medium temp.</b>	<b>kWh/kWh</b>	<b>5,17</b>	<b>5,32</b>	<b>5,13</b>	<b>5,07</b>	<b>4,97</b>	<b>5,31</b>	<b>5,29</b>	<b>5,12</b>
	SEPR <sub>23/18°C</sub> Process high temp.	kWh/kWh	5,21	5,25	5,19	5,10	5,10	5,32	5,37	5,39
	<b>SEPR<sub>-2/-8°C</sub> Process medium temp.</b>	<b>kWh/kWh</b>	<b>3,09</b>	<b>3,13</b>	<b>3,11</b>	<b>3,02</b>	<b>3,08</b>	<b>3,02</b>	<b>3,07</b>	<b>3,02</b>
Part Load integrated values	IPLV.IP	Btu/Wh	16,58	16,99	16,55	16,62	16,58	17,09	17,16	16,82
Part Load integrated values	IPLV.SI	kW/kW	4,83	4,95	4,82	4,84	4,81	4,97	4,98	4,89
<b>Unit + option 15LS</b>	Nominal capacity	kW	165	180	198	217	256	296	328	361
	Full load performances* CA1	EER	kW/kW	3,05	3,24	3,04	3,02	2,81	2,96	2,86
Seasonal energy efficiency**	<b>SEER<sub>12/7°C</sub> Comfort low temp.</b>	<b>kWh/kWh</b>	<b>4,49</b>	<b>4,64</b>	<b>4,45</b>	<b>4,47</b>	<b>4,35</b>	<b>4,70</b>	<b>4,67</b>	<b>4,62</b>
	$\eta_s$ cool <sub>12/7°C</sub>	%	<b>177</b>	<b>183</b>	<b>175</b>	<b>176</b>	<b>171</b>	<b>185</b>	<b>184</b>	<b>182</b>
	<b>SEER<sub>23/18°C</sub> Comfort medium temp.</b>	<b>kWh/kWh</b>	<b>5,27</b>	<b>5,52</b>	<b>5,22</b>	<b>5,26</b>	<b>4,99</b>	<b>5,66</b>	<b>5,55</b>	<b>5,43</b>
	SEPR <sub>23/18°C</sub> Process high temp.	kWh/kWh	5,27	5,42	5,34	5,19	5,14	5,44	5,47	5,60
	<b>SEPR<sub>-2/-8°C</sub> Process medium temp.</b>	<b>kWh/kWh</b>	<b>3,06</b>	<b>3,11</b>	<b>3,08</b>	<b>3,00</b>	<b>3,04</b>	<b>3,09</b>	<b>3,14</b>	<b>3,09</b>
<b>Sound levels</b>										
<b>Standard unit</b>										
Sound power <sup>(1)</sup>	dB(A)	91,0	91,5	91,5	92,0	92,0	93,0	93,0	93,5	
Sound pressure at 10 m <sup>(2)</sup>	dB(A)	58,5	59,5	59,5	60,0	60,0	60,5	60,5	61,0	
<b>Unit + option 15LS<sup>(3)</sup></b>										
Sound power <sup>(1)</sup>	dB(A)	85,5	85,5	85,5	86,5	86,5	87,5	87,5	88,0	
Sound pressure at 10 m <sup>(2)</sup>	dB(A)	53,0	53,5	53,5	54,5	54,5	55,5	55,5	55,5	
<b>Dimensions - standard unit</b>										
<b>Standard unit</b>										
Length	mm	2410	2410	2410	2410	2410	3604	3604	3604	
Width	mm	2253	2253	2253	2253	2253	2253	2253	2253	
Height	mm	2324	2324	2324	2324	2324	2324	2324	2324	
<b>Unit + option 307<sup>(3)</sup></b>										
Length	mm	3604	3604	3604	3604	3604	4798	4798	4798	
<b>Operating weight<sup>(4)</sup></b>										
Standard unit	kg	1349	1397	1397	1521	1556	1995	2049	2211	
Unit + option 15LS <sup>(3)</sup>	kg	1432	1480	1480	1630	1665	2122	2176	2356	
Unit + option 15LS + option 116W <sup>(3)</sup>	kg	1567	1615	1615	1765	1811	2271	2371	2551	
Unit + option 15LS + option 116W + option 307 <sup>(3)</sup>	kg	2550	2598	2598	2748	2794	3258	3357	3537	

\* In accordance with EN14511-3:2022.  
 \*\* In accordance with EN14825:2022, average climate conditions  
 CA1 Cooling mode conditions: evaporator water inlet/outlet temperature 12 °C/7 °C, outdoor air temperature 35 °C, evaporator fouling factor 0 m<sup>2</sup>. k/W  
 $\eta_s$  cool<sub>12/7°C</sub> & SEER<sub>12/7°C</sub> **Values in bold comply with the applicable Ecodesign Regulation (EU) No. 2016/2281 for Comfort applications**  
 SEER<sub>23/18°C</sub> **Values in bold comply with the applicable Ecodesign Regulation (EU) No. 2016/2281 for Comfort applications**  
 SEPR<sub>12/7°C</sub> Applicable Ecodesign regulation (UE) No 2016/2281  
 SEPR<sub>-2/-8°C</sub> **Applicable Ecodesign regulation (UE) No 2015/1095**  
 IPLV.IP Calculated as per AHRI standard 550-590  
 IPLV.SI Calculated as per AHRI standard 551-591.  
 (1) In dB ref=10<sup>-12</sup> W, (A) weighting. Declared dual-number noise emission value in accordance with ISO 4871 with an uncertainty of +/-3 dB(A). Measured in accordance with ISO 9614-1 and certified by Eurovent.  
 (2) In dB ref 20 µPa, (A) weighting. Declared dual-number noise emission value in accordance with ISO 4871 with an uncertainty of +/-3 dB(A). For information, calculated from the sound power Lw(A).  
 (3) Options: 15LS = Very low noise level, 116W = Variable-speed high pressure dual-pump hydraulic module, 307 = Water buffer tank module  
 (4) Values are guidelines only. Refer to the unit name plate.



Eurovent certified values

PRESENTATION  
COOLING  
HEATING  
AIR TREATMENT  
CONTROLS



## PHYSICAL DATA, SIZES 170R TO 380R

30RB		170R	190R	210R	230R	270R	310R	340R	380R
<b>Compressors</b>		Hermetic Scroll 48,3 r/s							
Circuit A		1	1	1	2	2	2	2	3
Circuit B		2	2	2	2	2	3	3	3
Number of power stages		3	3	3	4	4	5	5	6
<b>Unit PED category</b>		III	III	III	III	III	III	III	III
<b>Refrigerant<sup>(4)</sup></b>		R32 / A2L /GWP= 675 as per AR4							
Circuit A	kg	6,3	9,4	9,4	11,1	11,5	12,2	13,0	17,7
	tCO <sub>2</sub> e	4,2	6,3	6,3	7,5	7,8	8,2	8,8	11,9
Circuit B	kg	11,1	11,1	11,1	11,1	11,5	17,1	17,9	18,5
	tCO <sub>2</sub> e	7,5	7,5	7,5	7,5	7,8	11,5	12,0	12,5
<b>Oil</b>									
Circuit A	l	6,60	6,60	6,60	13,20	13,20	13,20	13,20	19,80
Circuit B	l	13,20	13,20	13,20	13,20	13,20	19,80	19,80	19,80
<b>Capacity control</b>		SmartVu™							
Minimum capacity	%	33	33	33	25	25	20	20	17
<b>Condenser</b>		All-aluminium micro-channel coils (MCHC)							
<b>Fans</b>		Axial Flying Bird 6 with rotating impeller							
<b>Standard unit</b>									
Quantity		3	4	4	4	4	5	5	6
Maximum total air flow	l/s	14460	19280	19280	19280	19280	24100	24100	28920
Maximum rotation speed	r/s	16	16	16	16	16	16	16	16
<b>Evaporator</b>		Direct expansion brazed-plate heat exchanger							
Water volume	l	15	15	15	19	27	27	35	44
Max. water-side operating pressure without hydraulic module	kPa	1000	1000	1000	1000	1000	1000	1000	1000
<b>Hydraulic module (option)</b>		Pump, Victaulic screen filter, relief valve, water and air vent valve, pressure sensors							
Pump		Centrifugal pump, monocell, 48,3 r/s, low or high pressure (as required), single or dual (as required)							
Expansion tank volume (option)	l	50	50	50	50	80	80	80	80
Buffer tank volume (option)	l	550	550	550	550	550	550	550	550
Max. water-side operating pressure with hydraulic module	kPa	400	400	400	400	400	400	400	400
<b>Water connections with or without hydraulic module</b>		Victaulic® type							
Connections	inches	3	3	3	3	3	4	4	4
External diameter	mm	88,9	88,9	88,9	88,9	88,9	114,3	114,3	114,3
<b>Casing paintwork</b>		Colour code RAL 7035							

(4) Values are guidelines only. Refer to the unit name plate.

PHYSICAL DATA, SIZES 410R TO 950R

30RB		410R	450R	480R	550R	610R	670R	720R	770R	800R	870R	950R	
<b>Cooling</b>													
<b>Standard unit</b>	Nominal capacity	kW	416	451	484	553	616	677	726	782	807	882	943
	Full load performances*	EER	kW/kW	3,10	3,15	3,09	3,08	3,16	3,14	3,06	3,07	3,04	3,00
Seasonal energy efficiency**	<b>SEER<sub>12/7°C</sub> Comfort low temp.</b>	<b>kWh/kWh</b>	<b>4,61</b>	<b>4,72</b>	<b>4,72</b>	<b>4,72</b>	<b>4,77</b>	<b>4,85</b>	<b>4,80</b>	<b>4,84</b>	<b>4,83</b>	<b>4,79</b>	<b>4,72</b>
	<b>ηs cool<sub>12/7°C</sub></b>	<b>%</b>	<b>182</b>	<b>186</b>	<b>186</b>	<b>186</b>	<b>188</b>	<b>191</b>	<b>189</b>	<b>191</b>	<b>190</b>	<b>189</b>	<b>186</b>
	<b>SEER<sub>23/18°C</sub> Comfort medium temp.</b>	<b>kWh/kWh</b>	<b>5,58</b>	<b>5,77</b>	<b>5,72</b>	<b>5,72</b>	<b>6,01</b>	<b>6,01</b>	<b>5,87</b>	<b>5,99</b>	<b>5,95</b>	<b>5,96</b>	<b>5,79</b>
	SEPR <sub>23/18°C</sub> Process high temp.	kWh/kWh	5,43	5,47	5,46	5,43	5,41	5,44	5,34	5,39	5,35	5,28	5,17
	<b>SEPR<sub>-2/-8°C</sub> Process medium temp.</b>	<b>kWh/kWh</b>	<b>3,08</b>	<b>3,05</b>	<b>3,07</b>	<b>3,06</b>	<b>3,45</b>	<b>3,38</b>	<b>3,42</b>	<b>3,36</b>	<b>3,38</b>	<b>3,33</b>	<b>3,36</b>
Part Load integrated values	IPLV.IP	Btu/Wh	16,97	17,11	17,10	17,10	17,47	17,41	17,22	17,39	17,34	17,24	17,03
Part Load integrated values	IPLV.SI	kW/kW	4,931	4,977	4,973	4,966	5,070	5,061	5,016	5,062	5,049	5,021	4,962
<b>Unit + option 15LS</b>	Nominal capacity	kW	394	428	458	523	586	645	688	743	765	836	889
	Full load performances*	EER	kW/kW	2,86	2,94	2,85	2,85	2,94	2,94	2,83	2,85	2,81	2,77
Seasonal energy efficiency**	<b>SEER<sub>12/7°C</sub> Comfort low temp.</b>	<b>kWh/kWh</b>	<b>4,89</b>	<b>5,08</b>	<b>5,03</b>	<b>4,95</b>	<b>5,08</b>	<b>5,16</b>	<b>5,05</b>	<b>5,17</b>	<b>5,13</b>	<b>4,98</b>	<b>4,86</b>
	<b>ηs cool<sub>12/7°C</sub></b>	<b>%</b>	<b>193</b>	<b>200</b>	<b>198</b>	<b>195</b>	<b>200</b>	<b>204</b>	<b>199</b>	<b>204</b>	<b>202</b>	<b>196</b>	<b>191</b>
	<b>SEER<sub>23/18°C</sub> Comfort medium temp.</b>	<b>kWh/kWh</b>	<b>5,80</b>	<b>5,99</b>	<b>5,91</b>	<b>5,98</b>	<b>6,26</b>	<b>6,44</b>	<b>6,20</b>	<b>6,43</b>	<b>6,34</b>	<b>6,10</b>	<b>5,85</b>
	SEPR <sub>23/18°C</sub> Process high temp.	kWh/kWh	5,63	5,58	5,58	5,54	5,52	5,58	5,44	5,46	5,41	5,36	5,22
	<b>SEPR<sub>-2/-8°C</sub> Process medium temp.</b>	<b>kWh/kWh</b>	<b>3,16</b>	<b>3,13</b>	<b>3,15</b>	<b>3,15</b>	<b>3,54</b>	<b>3,46</b>	<b>3,49</b>	<b>3,44</b>	<b>3,46</b>	<b>3,41</b>	<b>3,44</b>
<b>Sound levels</b>													
<b>Standard unit</b>													
Sound power <sup>(1)</sup>		dB(A)	93,5	94,0	94,0	94,5	97,5	97,5	98,0	98,0	98,5	98,5	99,0
Sound pressure at 10 m <sup>(2)</sup>		dB(A)	61,5	61,5	61,5	62,0	65,0	65,0	66,0	65,0	66,0	66,0	66,5
<b>Unit + option 15LS<sup>(3)</sup></b>													
Sound power <sup>(1)</sup>		dB(A)	88,0	88,5	88,5	89,0	92,5	92,5	93,0	93,0	93,5	93,5	94,5
Sound pressure at 10 m <sup>(2)</sup>		dB(A)	56,0	56,0	56,5	57,0	60,5	60,0	60,5	60,0	61,0	60,5	61,5
<b>Dimensions - standard unit</b>													
<b>Standard unit</b>													
Length	mm		3604	4798	4798	4798	5992	5992	5992	7186	7186	7186	7186
Width	mm		2253	2253	2253	2253	2253	2253	2253	2253	2253	2253	2253
Height	mm		2324	2324	2324	2324	2324	2324	2324	2324	2324	2324	2324
<b>Unit + option 307<sup>(3)</sup></b>													
Length	mm		4798	5992	5992	5992	7186	7186	7186	8380	8380	8380	8380
<b>Operating weight<sup>(4)</sup></b>													
Standard unit	kg		2269	2697	2722	2927	3265	3511	3511	4042	4042	4291	4291
Unit + option 15LS <sup>(3)</sup>	kg		2414	2860	2885	3108	3398	3664	3664	4216	4216	4485	4485
Unit + option 15LS + option 116W <sup>(3)</sup>	kg		2609	3094	3119	3379	3708	3974	3974	4605	4605	4874	4874
Unit + option 15LS + option 116W + option 307 <sup>(3)</sup>	kg		3594	4086	4111	4371	4715	4981	4981	5626	5626	5895	5895

\* In accordance with EN14511-3:2022.  
 \*\* In accordance with EN14825:2022, average climate conditions  
 CA1 Cooling mode conditions: evaporator water inlet/outlet temperature 12 °C/7 °C, outdoor air temperature 35 °C, evaporator fouling factor 0 m<sup>2</sup>. kW/W  
**Values in bold comply with the applicable Ecodesign Regulation (EU) No. 2016/2281 for Comfort applications**  
**Values in bold comply with the applicable Ecodesign Regulation (EU) No. 2016/2281 for Comfort applications**  
 Applicable Ecodesign regulation (UE) No 2016/2281  
**Applicable Ecodesign regulation (UE) No 2015/1095**  
 IPLV.IP Calculated as per AHRI standard 550-590  
 IPLV.SI Calculated as per AHRI standard 551-591.  
 (1) In dB ref=10<sup>-12</sup> W, (A) weighting. Declared dual-number noise emission value in accordance with ISO 4871 with an uncertainty of +/-3 dB(A). Measured in accordance with ISO 9614-1 and certified by Eurovent.  
 (2) In dB ref 20 µPa, (A) weighting. Declared dual-number noise emission value in accordance with ISO 4871 with an uncertainty of +/-3 dB(A). For information, calculated from the sound power Lw(A).  
 (3) Options: 15LS = Very low noise level, 116W = Variable-speed high pressure dual-pump hydraulic module, 307 = Water buffer tank module  
 (4) Values are guidelines only. Refer to the unit name plate.



Eurovent certified values

**PHYSICAL DATA, SIZES 410R TO 950R**

30RB		410R	450R	480R	550R	610R	670R	720R	770R	800R	870R	950R
<b>Compressors</b>		Hermetic Scroll 48,3 r/s										
Circuit A		3	3	3	4	2	3	3	3	3	4	4
Circuit B		3	4	4	4	3	3	3	4	4	4	4
Number of power stages		6	7	7	8	5	6	6	7	7	8	8
<b>Unit PED category</b>		III	IV	IV	IV	III	III	III	IV	IV	IV	IV
<b>Refrigerant<sup>(4)</sup></b>		R32 / A2L /GWP= 675 as per AR4										
Circuit A	kg	18,5	18,8	19,1	24,4	23,0	24,5	24,5	27,3	27,3	30,4	30,4
	tCO <sub>2</sub> e	12,5	12,7	12,9	16,5	15,5	16,5	16,5	18,4	18,4	20,5	20,5
Circuit B	kg	19,3	24,5	24,9	25,4	24,5	24,5	24,5	30,4	30,4	30,4	30,4
	tCO <sub>2</sub> e	13,0	16,5	16,8	17,1	16,5	16,5	16,5	20,5	20,5	20,5	20,5
<b>Oil</b>												
Circuit A	l	19,8	19,8	19,8	26,4	13,2	19,8	19,8	19,8	19,8	26,4	26,4
Circuit B	l	19,8	26,4	26,4	26,4	19,8	19,8	19,8	26,4	26,4	26,4	26,4
<b>Capacity control</b>		SmartVu™										
Minimum capacity	%	17	14	14	13	20	17	17	14	14	13	13
<b>Condenser</b>		All-aluminium micro-channel coils (MCHE)										
<b>Fans</b>		Axial Flying Bird 6 with rotating impeller										
<b>Standard unit</b>												
Quantity		6	7	7	8	9	10	10	11	11	12	12
Maximum total air flow	l/s	28920	33740	33740	38560	43380	48200	48200	53020	53020	57840	57840
Maximum rotation speed	r/s	16	16	16	16	16	16	16	16	16	16	16
<b>Evaporator</b>		Direct expansion brazed-plate heat exchanger										
Water volume	l	44	44	47	53	73	73	73	84	84	84	84
Max. water-side operating pressure without hydraulic module	kPa	1000	1000	1000	1000	1000	1000	1000	1000	1000	1000	1000
<b>Hydraulic module (option)</b>		Pump, Victaulic screen filter, relief valve, water and air vent valve, pressure sensors										
Pump		Centrifugal pump, monocell, 48,3 r/s, low or high pressure (as required), single or dual (as required)										
Expansion tank volume (option)	l	80	80	80	80	80	80	80	80	80	80	80
Buffer tank volume (option)	l	550	550	550	550	550	550	550	550	550	550	550
Max. water-side operating pressure with hydraulic module	kPa	400	400	400	400	400	400	400	400	400	400	400
<b>Water connections with or without hydraulic module</b>		Victaulic® type										
Connections	inches	4	4	4	4	5	5	5	5	5	5	5
External diameter	mm	114,3	114,3	114,3	114,3	139,7	139,7	139,7	139,7	139,7	139,7	139,7
<b>Casing paintwork</b>		Colour code RAL 7035										

(4) Values are guidelines only. Refer to the unit name plate.

PHYSICAL PROPERTIES, SIZES 170R TO 410R

30RBP		170R	190R	210R	230R	270R	310R	340R	380R	410R
-------	--	------	------	------	------	------	------	------	------	------

Cooling

<b>Standard unit</b>	Nominal capacity	kW	172	187	206	227	270	311	346	380	416
	Full load performances* CA1	EER	kW/kW	3,20	3,36	3,21	3,16	3,03	3,15	3,09	3,14
Seasonal energy efficiency**	<b>SEER<sub>12/7°C</sub> Comfort low temp.</b>	<b>kWh/kWh</b>	<b>4,82</b>	<b>5,02</b>	<b>4,84</b>	<b>4,94</b>	<b>4,79</b>	<b>5,25</b>	<b>5,15</b>	<b>5,09</b>	<b>5,11</b>
	$\eta_s$ cool <sub>12/7°C</sub>	%	190	198	191	195	189	207	203	201	201
	<b>SEER<sub>23/18°C</sub> Comfort medium temp.</b>	<b>kWh/kWh</b>	<b>5,98</b>	<b>6,23</b>	<b>5,93</b>	<b>5,99</b>	<b>5,69</b>	<b>6,35</b>	<b>6,17</b>	<b>6,13</b>	<b>6,07</b>
	SEPR <sub>12/7°C</sub> Process high temp.	kWh/kWh	6,30	6,61	6,42	6,13	5,97	6,30	6,24	6,36	6,30
	<b>SEPR<sub>-2/-8°C</sub> Process medium temp.</b>	<b>kWh/kWh</b>	<b>3,48</b>	<b>3,60</b>	<b>3,54</b>	<b>3,41</b>	<b>3,41</b>	<b>3,51</b>	<b>3,56</b>	<b>3,50</b>	<b>3,57</b>
Part Load integrated values	IPLV.IP	Btu/Wh	18,42	19,72	18,25	18,94	18,49	19,31	19,18	18,97	18,87
Part Load integrated values	IPLV.SI	kW/kW	5,37	5,73	5,31	5,51	5,37	5,61	5,56	5,50	5,47
<b>Unit + option 15LS</b>	Nominal capacity	kW	165	180	198	217	256	296	328	361	394
	Full load performances* CA1	EER	kW/kW	3,05	3,24	3,04	3,02	2,81	2,96	2,85	2,94
Seasonal energy efficiency**	<b>SEER<sub>12/7°C</sub> Comfort low temp.</b>	<b>kWh/kWh</b>	<b>4,80</b>	<b>5,00</b>	<b>4,81</b>	<b>4,90</b>	<b>4,73</b>	<b>5,20</b>	<b>5,08</b>	<b>5,11</b>	<b>5,09</b>
	$\eta_s$ cool <sub>12/7°C</sub>	%	189	197	189	193	186	205	200	201	201
	<b>SEER<sub>23/18°C</sub> Comfort medium temp.</b>	<b>kWh/kWh</b>	<b>5,95</b>	<b>6,18</b>	<b>5,83</b>	<b>5,98</b>	<b>5,58</b>	<b>6,36</b>	<b>6,13</b>	<b>6,03</b>	<b>5,95</b>
	SEPR <sub>12/7°C</sub> Process high temp.	kWh/kWh	6,24	6,66	6,49	6,12	5,88	6,34	6,25	6,42	6,34
	<b>SEPR<sub>-2/-8°C</sub> Process medium temp.</b>	<b>kWh/kWh</b>	<b>3,37</b>	<b>3,45</b>	<b>3,39</b>	<b>3,28</b>	<b>3,28</b>	<b>3,39</b>	<b>3,43</b>	<b>3,39</b>	<b>3,44</b>

Sound levels

<b>Standard unit</b>											
Sound power <sup>(1)</sup>	dB(A)	91,0	90,5	90,5	92,0	92,0	93,0	93,0	93,5	93,5	
Sound pressure at 10 m <sup>(2)</sup>	dB(A)	58,5	58,5	58,5	60,0	60,0	60,5	60,5	61,0	61,5	
<b>Unit + option 15LS<sup>(3)</sup></b>											
Sound power <sup>(1)</sup>	dB(A)	85,5	85,5	85,5	86,5	86,5	87,5	87,5	88,0	88,0	
Sound pressure at 10 m <sup>(2)</sup>	dB(A)	53,0	53,5	53,5	54,5	54,5	55,5	55,5	55,5	56,0	

Dimensions - standard unit

<b>Standard unit</b>											
Length	mm	2410	2410	2410	2410	2410	3604	3604	3604	3604	
Width	mm	2253	2253	2253	2253	2253	2253	2253	2253	2253	
Height	mm	2324	2324	2324	2324	2324	2324	2324	2324	2324	

Unit + option 307<sup>(3)</sup>

Length	mm	3604	3604	3604	3604	3604	4798	4798	4798	4798
--------	----	------	------	------	------	------	------	------	------	------

Operating weight<sup>(4)</sup>

Standard unit	kg	1349	1397	1397	1521	1556	1995	2049	2211	2269
Unit + option 15LS <sup>(3)</sup>	kg	1432	1480	1480	1630	1665	2122	2176	2356	2414
Unit + option 15LS + option 116W <sup>(3)</sup>	kg	1567	1615	1615	1765	1811	2271	2371	2551	2609
Unit + option 15LS + option 116W + option 307 <sup>(3)</sup>	kg	2550	2598	2598	2748	2794	3258	3357	3537	3594

\* In accordance with EN14511-3:2022.  
 \*\* In accordance with EN14825:2022, average climate conditions  
 CA1 Cooling mode conditions: evaporator water inlet/outlet temperature 12 °C/7 °C, outdoor air temperature 35 °C, evaporator fouling factor 0 m<sup>2</sup>, k/W  
 $\eta_s$  cool<sub>12/7°C</sub> & SEER<sub>12/7°C</sub> **Values in bold comply with Ecodesign Regulation (EU) No. 2016/2281 for Comfort applications**  
 SEER<sub>23/18°C</sub> **Values in bold comply with Ecodesign Regulation (EU) No. 2016/2281 for Comfort applications**  
 SEPR<sub>12/7°C</sub> Values calculated in accordance with EN 14825:2022  
 SEPR<sub>-2/-8°C</sub> **Values calculated in accordance with EN 14825:2022**  
 IPLV.IP Calculated as per AHRI standard 550-590  
 IPLV.SI Calculated as per AHRI standard 551-591.  
 (1) In dB ref=10<sup>-12</sup> W, (A) weighting. Declared dual-number noise emission value in accordance with ISO 4871 with an uncertainty of +/-3 dB(A). Measured in accordance with ISO 9614-1 and certified by Eurovent.  
 (2) In dB ref 20 µPa, (A) weighting. Declared dual-number noise emission value in accordance with ISO 4871 with an uncertainty of +/-3 dB(A). For information, calculated from the sound power Lw(A).  
 (3) Options: 15LS = Very low noise level, 116W = Variable-speed high pressure dual-pump hydraulic module, 307 = Water buffer tank module  
 (4) Values are guidelines only. Refer to the unit name plate.



Eurovent certified values

PRESENTATION  
COOLING  
HEATING  
AIR TREATMENT  
CONTROLS

**PHYSICAL PROPERTIES, SIZES 170R TO 410R**

30RBP		170R	190R	210R	230R	270R	310R	340R	380R	410R
<b>Compressors</b>		Hermetic Scroll 48,3 r/s								
Circuit A		1	1	1	2	2	2	2	3	3
Circuit B		2	2	2	2	2	3	3	3	3
Number of power stages		3	3	3	4	4	5	5	6	6
<b>Unit PED category</b>		III	III	III	III	III	III	III	III	III
<b>Refrigerant<sup>(4)</sup></b>		R32 / A2L /GWP= 675 as per AR4								
Circuit A	kg	6,3	9,4	9,4	11,1	11,5	12,2	13,0	17,7	18,5
	tCO <sub>2</sub> e	4,2	6,3	6,3	7,5	7,8	8,2	8,8	11,9	12,5
Circuit B	kg	11,1	11,1	11,1	11,1	11,5	17,1	17,9	18,5	19,3
	tCO <sub>2</sub> e	7,5	7,5	7,5	7,5	7,8	11,5	12,0	12,5	13,0
<b>Oil</b>										
Circuit A	l	6,6	6,6	6,60	13,2	13,2	13,2	13,2	19,8	19,8
Circuit B	l	13,2	13,2	13,2	13,2	13,2	19,8	19,8	19,8	19,8
<b>Capacity control</b>		SmartVu™								
Minimum capacity	%	33	33	33	25	25	20	20	17	17
<b>Condenser</b>		All-aluminium micro-channel coils (MCHE)								
<b>Fans</b>		Axial Flying Bird 6 with rotating impeller								
<b>Standard unit</b>										
Quantity		3	4	4	4	4	5	5	6	6
Maximum total air flow	l/s	14460	19280	19280	19280	19280	24100	24100	28920	28920
Maximum rotation speed	r/s	16	16	16	16	16	16	16	16	16
<b>Evaporator</b>		Direct expansion brazed-plate heat exchanger								
Water volume	l	15	15	15	19	27	27	35	44	44
Max. water-side operating pressure without hydraulic module	kPa	1000	1000	1000	1000	1000	1000	1000	1000	1000
<b>Hydraulic module (option)</b>		Pump, Victaulic screen filter, relief valve, water and air vent valve, pressure sensors								
Pump		Centrifugal pump, monocoil, 48,3 r/s, low or high pressure (as required), single or dual (as required)								
Expansion tank volume (option)	l	50	50	50	50	50	80	80	80	80
Buffer tank volume (option)	l	550	550	550	550	550	550	550	550	550
Max. water-side operating pressure with hydraulic module	kPa	400	400	400	400	400	400	400	400	400
<b>Water connections with or without hydraulic module</b>		Victaulic® type								
Connections	inches	3	3	3	3	3	4	4	4	4
External diameter	mm	88,9	88,9	88,9	88,9	88,9	114,3	114,3	114,3	114,3
<b>Casing paintwork</b>		Colour code RAL 7035								

(4) Values are guidelines only. Refer to the unit name plate.



PHYSICAL PROPERTIES, SIZES 450R TO 950R

30RBP		450R	480R	550R	610R	670R	720R	770R	800R	870R	950R			
<b>Cooling</b>														
<b>Standard unit</b>	Nominal capacity	kW		451	484	553	616	677	726	782	807	882	944	
	Full load performances* CA1	EER		kW/kW		3,14	3,09	3,08	3,15	3,14	3,06	3,07	3,04	3,00
Seasonal energy efficiency**	<b>SEER<sub>12/7°C</sub> Comfort low temp.</b>	<b>kWh/kWh</b>		<b>5,28</b>	<b>5,24</b>	<b>5,29</b>	<b>5,32</b>	<b>5,32</b>	<b>5,20</b>	<b>5,33</b>	<b>5,30</b>	<b>5,31</b>	<b>5,18</b>	
	$\eta_s$ cool <sub>12/7°C</sub>	%		<b>208</b>	<b>207</b>	<b>209</b>	<b>210</b>	<b>210</b>	<b>205</b>	<b>210</b>	<b>209</b>	<b>209</b>	<b>204</b>	
	<b>SEER<sub>23/18°C</sub> Comfort medium temp.</b>	<b>kWh/kWh</b>		<b>6,33</b>	<b>6,23</b>	<b>6,32</b>	<b>6,56</b>	<b>6,51</b>	<b>6,28</b>	<b>6,54</b>	<b>6,47</b>	<b>6,56</b>	<b>6,32</b>	
	SEPR <sub>12/7°C</sub> Process high temp.	kWh/kWh		6,41	6,32	6,27	6,27	6,33	6,14	6,25	6,18	6,07	5,88	
	<b>SEPR<sub>-2/-8°C</sub> Process medium temp.</b>	<b>kWh/kWh</b>		<b>3,55</b>	<b>3,55</b>	<b>3,55</b>	<b>3,91</b>	<b>3,82</b>	<b>3,83</b>	<b>3,79</b>	<b>3,80</b>	<b>3,74</b>	<b>3,74</b>	
Part Load integrated values	IPLV.IP	Btu/Wh		19,38	19,24	19,21	19,65	19,48	19,04	19,58	19,45	19,35	18,94	
Part Load integrated values	IPLV.SI	kW/kW		5,63	5,59	5,58	5,69	5,64	5,52	5,68	5,65	5,62	5,51	
<b>Unit + option 15LS</b>	Nominal capacity	kW		428	458	523	586	645	688	743	765	836	890	
	Full load performances* CA1	EER		kW/kW		2,93	2,85	2,85	2,94	2,93	2,83	2,85	2,81	2,77
Seasonal energy efficiency**	<b>SEER<sub>12/7°C</sub> Comfort low temp.</b>	<b>kWh/kWh</b>		<b>5,37</b>	<b>5,30</b>	<b>5,21</b>	<b>5,24</b>	<b>5,35</b>	<b>5,20</b>	<b>5,43</b>	<b>5,38</b>	<b>5,22</b>	<b>5,07</b>	
	$\eta_s$ cool <sub>12/7°C</sub>	%		<b>212</b>	<b>209</b>	<b>205</b>	<b>207</b>	<b>211</b>	<b>205</b>	<b>214</b>	<b>212</b>	<b>206</b>	<b>200</b>	
	<b>SEER<sub>23/18°C</sub> Comfort medium temp.</b>	<b>kWh/kWh</b>		<b>6,25</b>	<b>6,12</b>	<b>6,25</b>	<b>6,41</b>	<b>6,59</b>	<b>6,33</b>	<b>6,69</b>	<b>6,60</b>	<b>6,34</b>	<b>6,06</b>	
	SEPR <sub>12/7°C</sub> Process high temp.	kWh/kWh		6,38	6,29	6,24	6,26	6,32	6,11	6,17	6,10	6,03	5,79	
	<b>SEPR<sub>-2/-8°C</sub> Process medium temp.</b>	<b>kWh/kWh</b>		<b>3,43</b>	<b>3,44</b>	<b>3,43</b>	<b>3,91</b>	<b>3,82</b>	<b>3,83</b>	<b>3,80</b>	<b>3,80</b>	<b>3,73</b>	<b>3,73</b>	
<b>Sound levels</b>														
<b>Standard unit</b>														
Sound power <sup>(1)</sup>	dB(A)		94,0	94,0	94,5	97,5	97,5	98,0	98,0	98,5	98,5	99,0		
Sound pressure at 10 m <sup>(2)</sup>	dB(A)		61,5	61,5	62,0	65,0	65,0	66,0	65,0	66,0	66,0	66,5		
<b>Unit + option 15LS<sup>(3)</sup></b>														
Sound power <sup>(1)</sup>	dB(A)		88,5	88,5	89,0	92,5	92,5	93,0	93,0	93,5	93,5	94,5		
Sound pressure at 10 m <sup>(2)</sup>	dB(A)		56,0	56,5	57,0	60,5	60,0	60,5	60,0	61,0	60,5	61,5		
<b>Dimensions - standard unit</b>														
<b>Standard unit</b>														
Length	mm		4798	4798	4798	5992	5992	5992	7186	7186	7186	7186		
Width	mm		2253	2253	2253	2253	2253	2253	2253	2253	2253	2253		
Height	mm		2324	2324	2324	2324	2324	2324	2324	2324	2324	2324		
<b>Unit + option 307<sup>(3)</sup></b>														
Length	mm		5992	5992	5992	7186	7186	7186	8380	8380	8380	8380		
<b>Operating weight<sup>(4)</sup></b>														
Standard unit	kg		2697	2722	2927	3265	3511	3511	4042	4042	4291	4291		
Unit + option 15LS <sup>(3)</sup>	kg		2860	2885	3108	3398	3664	3664	4216	4216	4485	4485		
Unit + option 15LS + option 116W <sup>(3)</sup>	kg		3094	3119	3379	3708	3974	3974	4605	4605	4874	4874		
Unit + option 15LS + option 116W + option 307 <sup>(3)</sup>	kg		4086	4111	4371	4715	4981	4981	5626	5626	5895	5895		

\* In accordance with EN14511-3:2022.  
 \*\* In accordance with EN14825:2022, average climate conditions  
 CA1 Cooling mode conditions: evaporator water inlet/outlet temperature 12 °C/7 °C, outdoor air temperature 35 °C, evaporator fouling factor 0 m<sup>2</sup>, k/W  
 $\eta_s$  cool<sub>12/7°C</sub> & SEER<sub>12/7°C</sub> **Values in bold comply with Ecodesign Regulation (EU) No. 2016/2281 for Comfort applications**  
 SEER<sub>23/18°C</sub> **Values in bold comply with Ecodesign Regulation (EU) No. 2016/2281 for Comfort applications**  
 SEPR<sub>12/7°C</sub> Values calculated in accordance with EN 14825:2022  
 SEPR<sub>-2/-8°C</sub> **Values calculated in accordance with EN 14825:2022**  
 IPLV.IP Calculated as per AHRI standard 550-590  
 IPLV.SI Calculated as per AHRI standard 551-591.  
 (1) In dB ref=10<sup>-12</sup> W, (A) weighting. Declared dual-number noise emission value in accordance with ISO 4871 with an uncertainty of +/-3 dB(A). Measured in accordance with ISO 9614-1 and certified by Eurovent.  
 (2) In dB ref 20 µPa, (A) weighting. Declared dual-number noise emission value in accordance with ISO 4871 with an uncertainty of +/-3 dB(A). For information, calculated from the sound power Lw(A).  
 (3) Options: 15LS = Very low noise level, 116W = Variable-speed high pressure dual-pump hydraulic module, 307 = Water buffer tank module  
 (4) Values are guidelines only. Refer to the unit name plate.



Eurovent certified values

**PHYSICAL PROPERTIES, SIZES 450R TO 950R**

30RBP		450R	480R	550R	610R	670R	720R	770R	800R	870R	950R
<b>Compressors</b>		Hermetic Scroll 48,3 r/s									
Circuit A		3	3	4	2	3	3	3	3	4	4
Circuit B		4	4	4	3	3	3	4	4	4	4
Number of power stages		7	7	8	5	6	6	7	7	8	8
<b>Unit PED category</b>		IV	IV	IV	III	III	III	IV	IV	IV	IV
<b>Refrigerant<sup>(4)</sup></b>		R32 / A2L /GWP= 675 as per AR4									
Circuit A	kg	18,8	19,1	24,4	23,0	24,5	24,5	27,3	27,3	30,4	30,4
	tCO <sub>2</sub> e	12,7	12,9	16,5	15,5	16,5	16,5	18,4	18,4	20,5	20,5
Circuit B	kg	24,5	24,9	25,4	24,5	24,5	24,5	30,4	30,4	30,4	30,4
	tCO <sub>2</sub> e	16,5	16,8	17,1	16,5	16,5	16,5	20,5	20,5	20,5	20,5
<b>Oil</b>											
Circuit A	l	19,8	19,8	26,4	13,2	19,8	19,8	19,8	19,8	26,4	26,4
Circuit B	l	26,4	26,4	26,4	19,8	19,8	19,8	26,4	26,4	26,4	26,4
<b>Capacity control</b>		SmartVu™									
Minimum capacity	%	14	14	13	20	17	17	14	14	13	13
<b>Condenser</b>		All-aluminium micro-channel coils (MCHE)									
<b>Fans</b>		Axial Flying Bird 6 with rotating impeller									
<b>Standard unit</b>											
Quantity		7	7	8	9	10	10	11	11	12	12
Maximum total air flow	l/s	33740	33740	38560	43380	48200	48200	53020	53020	57840	57840
Maximum rotation speed	r/s	16	16	16	16	16	16	16	16	16	16
<b>Evaporator</b>		Direct expansion brazed-plate heat exchanger									
Water volume	l	44	47	53	73	73	73	84	84	84	84
Max. water-side operating pressure without hydraulic module	kPa	1000	1000	1000	1000	1000	1000	1000	1000	1000	1000
<b>Hydraulic module (option)</b>		Pump, Victaulic screen filter, relief valve, water and air vent valve, pressure sensors									
Pump		Centrifugal pump, monocell, 48,3 r/s, low or high pressure (as required), single or dual (as required)									
Expansion tank volume (option)	l	80	80	80	80	80	80	80	80	80	80
Buffer tank volume (option)	l	550	550	550	550	550	550	550	550	550	550
Max. water-side operating pressure with hydraulic module	kPa	400	400	400	400	400	400	400	400	400	400
<b>Water connections with or without hydraulic module</b>		Victaulic® type									
Connections	inches	4	4	4	5	5	5	5	5	5	5
External diameter	mm	114,3	114,3	114,3	139,7	139,7	139,7	139,7	139,7	139,7	139,7
<b>Casing paintwork</b>		Colour code RAL 7035									

(4) Values are guidelines only. Refer to the unit name plate.

PHYSICAL DATA, SIZES 165R TO 520R

30RQ		165R	180R	210R	230R	270R	310R	330R	370R	400R	430R	470R	520R
------	--	------	------	------	------	------	------	------	------	------	------	------	------

Heating

Standard unit Full load performances*	HA1	Nominal capacity	kW	178	197	237	256	275	317	336	387	406	441	467	537
		COP	kW/kW	3,88	3,80	3,84	3,84	3,82	3,82	3,81	3,82	3,81	3,80	3,73	3,80
	HA2	Nominal capacity	kW	173	192	231	250	269	310	329	378	397	431	458	526
		COP	kW/kW	3,16	3,09	3,14	3,12	3,11	3,10	3,09	3,10	3,09	3,10	3,03	3,09
Seasonal energy efficiency**	HA1	<b>SCOP</b> <sub>30/35°C</sub>	<b>kWh/kWh</b>	<b>3,44</b>	<b>3,45</b>	<b>3,39</b>	<b>3,47</b>	<b>3,48</b>	<b>3,57</b>	<b>3,58</b>	<b>3,55</b>	<b>3,57</b>	<b>3,54</b>	<b>3,53</b>	<b>3,57</b>
		<b>ηs heat</b> <sub>30/35°C</sub>	<b>%</b>	<b>135</b>	<b>135</b>	<b>133</b>	<b>136</b>	<b>136</b>	<b>140</b>	<b>140</b>	<b>139</b>	<b>140</b>	<b>139</b>	<b>138</b>	<b>140</b>
		P <sub>rated</sub>	kW	139	155	186	200	217	250	266	305	321	349	371	400

Cooling

Standard unit Full load performances*	CA1	Nominal capacity	kW	164	181	215	236	254	302	324	362	381	413	439	500
		EER	kW/kW	2,87	2,73	2,86	2,81	2,76	2,85	2,80	2,82	2,76	2,82	2,74	2,74
Seasonal energy efficiency**		SEER <sub>12/7°C</sub> Comfort low temp.	kWh/kWh	3,91	3,81	3,88	3,88	3,84	4,15	4,21	4,14	4,07	4,04	4,03	4,05
		SEPR <sub>12/7°C</sub> Process high temp.	kWh/kWh	4,62	4,47	4,54	4,48	4,46	4,69	4,64	4,77	4,70	4,76	4,66	4,70
Unit + option 15LS Full load performances*	CA1	Nominal capacity	kW	155	171	204	223	239	285	305	341	358	389	414	470
		EER	kW/kW	2,73	2,55	2,73	2,63	2,56	2,66	2,59	2,64	2,57	2,64	2,55	2,55
Seasonal energy efficiency**		SEER <sub>12/7°C</sub> Comfort low temp.	kWh/kWh	4,17	4,01	4,18	4,08	4,04	4,48	4,50	4,46	4,33	4,44	4,38	4,32
		SEPR <sub>12/7°C</sub> Process high temp.	kWh/kWh	4,68	4,51	4,64	4,52	4,50	4,83	4,76	4,93	4,79	4,94	4,82	4,83

Sound levels

Standard unit															
Sound power <sup>(1)</sup>		dB(A)	90,5	91,0	91,5	92,0	92,0	93,0	93,5	94,0	94,0	94,5	94,5	95,0	
Sound pressure at 10 m <sup>(2)</sup>		dB(A)	58,0	58,5	59,5	60,0	60,0	60,5	61,0	61,5	61,5	62,0	62,0	62,5	
Unit + option 15LS <sup>(3)</sup>															
Sound power <sup>(1)</sup>		dB(A)	85,0	86,0	86,5	87,0	87,0	88,0	88,0	89,0	89,0	89,5	90,0	90,0	
Sound pressure at 10 m <sup>(2)</sup>		dB(A)	53,0	53,5	54,0	54,5	54,5	55,5	55,5	56,5	56,5	57,0	57,5	57,5	

Dimensions - standard unit

Standard unit															
Length		mm	2410	2410	2410	2410	2410	3604	3604	3604	3604	4798	4798	4798	
Width		mm	2253	2253	2253	2253	2253	2253	2253	2253	2253	2253	2253	2253	
Height		mm	2324	2324	2324	2324	2324	2324	2324	2324	2324	2324	2324	2324	

Unit + option 307<sup>(3)</sup>

Length		mm	3604	3604	3604	3604	3604	4798	4798	4798	4798	5992	5992	5992
--------	--	----	------	------	------	------	------	------	------	------	------	------	------	------

Operating weight<sup>(4)</sup>

Standard unit		kg	1569	1575	1784	1811	1817	2394	2452	2672	2678	3154	3180	3430
Unit + option 15LS <sup>(3)</sup>		kg	1652	1658	1892	1920	1926	2520	2579	2817	2823	3317	3343	3611
Unit + option 15LS + option 116W <sup>(3)</sup>		kg	1787	1793	2039	2067	2073	2715	2774	3051	3057	3551	3614	3882
Unit + option 15LS + option 116W + option 307 <sup>(3)</sup>		kg	2771	2777	3022	3049	3055	3725	3783	4060	4066	4551	4614	4882

\* In accordance with EN14511-3:2022.  
 \*\* In accordance with EN14825:2022, average climate conditions  
 HA1 Heating mode conditions: Water type heat exchanger water inlet/outlet temperature 30 °C/35 °C, outside air temperature tdb/twb = 7 °C db/6 °C wb, evaporator fouling factor 0 m<sup>2</sup>. k/W  
 HA2 Heating mode conditions: Water type heat exchanger water inlet/outlet temperature 40 °C/45 °C, outside air temperature tdb/twb = 7 °C db/6 °C wb, evaporator fouling factor 0 m<sup>2</sup>. k/W  
 CA1 Cooling mode conditions: evaporator water inlet/outlet temperature 12 °C/7 °C, outdoor air temperature 35 °C, evaporator fouling factor 0 m<sup>2</sup>. k/W  
**ηs heat<sub>30/35°C</sub> & SCOP<sub>30/35°C</sub>** Values in bold comply with Ecodesign Regulation (EU) No. 813/2013 for Heating applications  
**SEER<sub>12/7°C</sub> & SEPR<sub>12/7°C</sub>** Applicable Ecodesign regulation (EU) No. 2016/2281.  
 (1) In dB ref=10<sup>-12</sup> W, (A) weighting. Declared dual-number noise emission value in accordance with ISO 4871 with an uncertainty of +/-3 dB(A). Measured in accordance with ISO 9614-1 and certified by Eurovent. Cooling mode.  
 (2) In dB ref 20 μPa, (A) weighting. Declared dual-number noise emission value in accordance with ISO 4871 with an uncertainty of +/-3 dB(A). For information, calculated from the sound power Lw(A).  
 (3) Options: 15LS = Very low noise level, 116W = Variable-speed high pressure dual-pump hydraulic module, 307 = Water buffer tank module.  
 (4) Values are guidelines only. Refer to the unit name plate.



Eurovent certified values

**PHYSICAL DATA, SIZES 165R TO 520R**

30RQ		165R	180R	210R	230R	270R	310R	330R	370R	400R	430R	470R	520R
<b>Compressors</b>		Hermetic Scroll 48,3 r/s											
Circuit A/C		1	1	2	2	2	2	2	2	2	3	3	4
Circuit B/D		2	2	2	2	2	3	3	4	4	4	4	4
Number of power stages		3	3	4	4	4	5	5	6	6	7	7	8
<b>Unit PED category</b>		III	III	III	III	III	III	IV	IV	IV	IV	IV	IV
<b>Refrigerant<sup>(4)</sup></b>		R32 / A2L /GWP= 675 as per AR4											
Circuit A/C	kg	10,5	10,5	16,0	16,0	16,0	16,0	18,0	18,0	18,0	29,0	29,0	35,0
	tCO <sub>2</sub> e	7,1	7,1	10,8	10,8	10,8	10,8	12,2	12,2	12,2	19,6	19,6	23,6
Circuit B/D	kg	16,0	16,0	16,0	16,0	16,0	28,5	28,5	34,0	34,0	34,5	35,0	35,0
	tCO <sub>2</sub> e	10,8	10,8	10,8	10,8	10,8	19,2	19,2	23,0	23,0	23,3	23,6	23,6
<b>Oil</b>													
Circuit A/C		6,6	6,6	13,2	13,2	13,2	13,2	13,2	13,2	13,2	22,8	22,8	30,4
Circuit B/D		13,2	13,2	13,2	13,2	13,2	22,8	22,8	30,4	30,4	30,4	30,4	30,4
<b>Capacity control</b>		SmartVu™											
Minimum capacity	%	33	33	25	25	25	20	20	17	17	14	14	13
<b>Condenser</b>		Grooved copper tubes and aluminium fins											
<b>Fans</b>		Axial Flying Bird 6 with rotating impeller											
<b>Standard unit</b>													
Quantity		3	3	4	4	4	5	5	6	6	7	7	8
Maximum total air flow	l/s	14460	14460	19280	19280	19280	24100	24100	28920	28920	33740	33740	38560
Maximum rotation speed	r/s	16	16	16	16	16	16	16	16	16	16	16	16
<b>Evaporator</b>		Direct expansion brazed-plate heat exchanger											
Water volume	l	16,2	16,2	16,2	20,7	20,7	38,7	48,6	48,6	48,6	48,6	52,2	58,5
Max. water-side operating pressure without hydraulic module	kPa	1000	1000	1000	1000	1000	1000	1000	1000	1000	1000	1000	1000
<b>Hydraulic module (option)</b>		Pump, Victaulic screen filter, relief valve, water and air vent valve, pressure sensors											
Pump		Centrifugal pump, monocell, 48,3 r/s, low or high pressure (as required), single or dual (as required)											
Expansion tank volume (option)	l	50	50	50	50	50	80	80	80	80	80	80	80
Buffer tank volume (option)	l	550	550	550	550	550	550	550	550	550	550	550	550
Max. water-side operating pressure with hydraulic module	kPa	400	400	400	400	400	400	400	400	400	400	400	400
<b>Water connections with or without hydraulic module</b>		Victaulic® type											
Connections	inches	3	3	3	3	3	4	4	4	4	4	4	4
External diameter	mm	88,5	88,6	88,7	88,8	88,9	114,3	114,4	114,5	114,6	114,7	114,8	114,9
<b>Casing paintwork</b>		Colour code RAL 7035											

(4) Values are guidelines only. Refer to the unit name plate.

PHYSICAL DATA, SIZES 165R TO 520R

30RQP		165R	180R	210R	230R	270R	310R	330R	370R	400R	430R	470R	520R		
<b>Heating</b>															
<b>Standard unit Full load performances*</b>	HA1	Nominal capacity	kW	178	197	237	256	275	317	336	387	406	441	537	
		COP	kW/kW	3,88	3,80	3,84	3,84	3,82	3,82	3,81	3,82	3,81	3,80	3,73	3,80
	HA2	Nominal capacity	kW	173	192	231	250	269	310	329	378	397	431	458	526
		COP	kW/kW	3,16	3,09	3,14	3,13	3,11	3,10	3,09	3,10	3,09	3,10	3,03	3,10
Seasonal energy efficiency**	HA1	<b>SCOP</b> <sub>30/35°C</sub>	<b>kWh/kWh</b>	<b>3,67</b>	<b>3,66</b>	<b>3,74</b>	<b>3,77</b>	<b>3,80</b>	<b>3,87</b>	<b>3,86</b>	<b>3,90</b>	<b>3,91</b>	<b>3,92</b>	<b>3,89</b>	<b>3,96</b>
		<b>ηs heat</b> <sub>30/35°C</sub>	<b>%</b>	<b>144</b>	<b>143</b>	<b>147</b>	<b>148</b>	<b>149</b>	<b>152</b>	<b>151</b>	<b>153</b>	<b>153</b>	<b>154</b>	<b>153</b>	<b>155</b>
		P <sub>rated</sub>	kW	138	155	185	200	216	250	265	305	320	348	370	399
<b>Cooling</b>															
<b>Standard unit Full load performances*</b>	CA1	Nominal capacity	kW	164	181	215	236	254	302	324	362	381	413	439	500
		EER	kW/kW	2,87	2,72	2,86	2,80	2,76	2,85	2,80	2,82	2,76	2,81	2,74	2,73
Seasonal energy efficiency**		SEER <sub>12/7°C</sub> Comfort low temp.	kWh/kWh	4,41	4,23	4,48	4,41	4,34	4,78	4,81	4,88	4,87	4,81	4,75	4,81
		SEPR <sub>12/7°C</sub> Process high temp.	kWh/kWh	5,47	5,23	5,41	5,23	5,15	5,49	5,34	5,60	5,40	5,60	5,43	5,47
<b>Unit + option 15LS Full load performances*</b>	CA1	Nominal capacity	kW	155	171	204	223	239	285	305	341	358	389	414	470
		EER	kW/kW	2,73	2,55	2,69	2,61	2,56	2,66	2,59	2,63	2,56	2,64	2,55	2,54
Seasonal energy efficiency**		SEER <sub>12/7°C</sub> Comfort low temp.	kWh/kWh	4,38	4,23	4,41	4,37	4,35	4,73	4,76	4,91	4,78	4,94	4,86	4,75
		SEPR <sub>12/7°C</sub> Process high temp.	kWh/kWh	5,39	5,17	5,23	5,12	5,10	5,51	5,37	5,62	5,39	5,65	5,47	5,52
<b>Sound levels</b>															
<b>Standard unit</b>															
		Sound power <sup>(1)</sup>	dB(A)	90,5	91,0	91,5	92,0	92,0	93,0	93,5	94,0	94,0	94,5	94,5	95,0
		Sound pressure at 10 m <sup>(2)</sup>	dB(A)	58,0	58,5	59,5	60,0	60,0	60,5	61,0	61,5	61,5	62,0	62,0	62,5
<b>Unit + option 15LS<sup>(3)</sup></b>															
		Sound power <sup>(1)</sup>	dB(A)	85,0	86,0	86,5	87,0	87,0	88,0	88,0	89,0	89,0	89,5	90,0	90,0
		Sound pressure at 10 m <sup>(2)</sup>	dB(A)	53,0	53,5	54,0	54,5	54,5	55,5	55,5	56,5	56,5	57,0	57,5	57,5
<b>Dimensions - standard unit</b>															
<b>Standard unit</b>															
		Length	mm	2410	2410	2410	2410	2410	3604	3604	3604	3604	4798	4798	4798
		Width	mm	2253	2253	2253	2253	2253	2253	2253	2253	2253	2253	2253	2253
		Height	mm	2324	2324	2324	2324	2324	2324	2324	2324	2324	2324	2324	2324
<b>Unit + option 307<sup>(3)</sup></b>															
		Length	mm	3604	3604	3604	3604	3604	4798	4798	4798	4798	5992	5992	5992
<b>Operating weight<sup>(4)</sup></b>															
		Standard unit	kg	1569	1575	1784	1811	1817	2394	2452	2672	2678	3154	3180	3430
		Unit + option 15LS <sup>(3)</sup>	kg	1652	1658	1892	1920	1926	2520	2579	2817	2823	3317	3343	3611
		Unit + option 15LS + option 116W <sup>(3)</sup>	kg	1787	1793	2039	2067	2073	2715	2774	3051	3057	3551	3614	3882
		Unit + option 15LS + option 116W + option 307 <sup>(3)</sup>	kg	2771	2777	3022	3049	3055	3725	3783	4060	4066	4551	4614	4882

\* In accordance with EN14511-3:2022.  
 \*\* In accordance with EN14825:2022, average climate conditions  
 HA1 Heating mode conditions: Water type heat exchanger water inlet/outlet temperature 30 °C/35 °C, outside air temperature tdb/twb = 7 °C db/6 °C wb, evaporator fouling factor 0 m<sup>2</sup>. k/W  
 HA2 Heating mode conditions: Water type heat exchanger water inlet/outlet temperature 40 °C/45 °C, outside air temperature tdb/twb = 7 °C db/6 °C wb, evaporator fouling factor 0 m<sup>2</sup>. k/W  
 CA1 Cooling mode conditions: evaporator water inlet/outlet temperature 12 °C/7 °C, outdoor air temperature 35 °C, evaporator fouling factor 0 m<sup>2</sup>. k/W  
**ηs heat<sub>30/35°C</sub> & SCOP<sub>30/35°C</sub>** Values in bold comply with Ecodesign Regulation (EU) No. 813/2013 for Heating applications  
**SEER<sub>12/7°C</sub> & SEPR<sub>12/7°C</sub>** Applicable Ecodesign regulation (EU) No. 2016/2281.  
 (1) In dB ref=10<sup>-12</sup> W, (A) weighting. Declared dual-number noise emission value in accordance with ISO 4871 with an uncertainty of +/-3 dB(A). Measured in accordance with ISO 9614-1 and certified by Eurovent. Cooling mode.  
 (2) In dB ref 20 μPa, (A) weighting. Declared dual-number noise emission value in accordance with ISO 4871 with an uncertainty of +/-3 dB(A). For information, calculated from the sound power Lw(A).  
 (3) Options: 15LS = Very low noise level, 116W = Variable-speed high pressure dual-pump hydraulic module, 307 = Water buffer tank module,  
 (4) Values are guidelines only. Refer to the unit name plate.



Eurovent certified values



**PHYSICAL DATA, SIZES 165R TO 520R**

30RQP		165R	180R	210R	230R	270R	310R	330R	370R	400R	430R	470R	520R
<b>Compressors</b>		Hermetic Scroll 48,3 r/s											
Circuit A/C		1	1	2	2	2	2	2	2	2	3	3	4
Circuit B/D		2	2	2	2	2	3	3	4	4	4	4	4
Number of power stages		3	3	4	4	4	5	5	6	6	7	7	8
<b>Unit PED category</b>		III	III	III	III	III	III	IV	IV	IV	IV	IV	IV
<b>Refrigerant<sup>(4)</sup></b>		R32 / A2L /GWP= 675 as per AR4											
Circuit A/C	kg	10,5	10,5	16,0	16,0	16,0	16,0	18,0	18,0	18,0	29,0	29,0	35,0
	tCO <sub>2</sub> e	7,1	7,1	10,8	10,8	10,8	10,8	12,2	12,2	12,2	19,6	19,6	23,6
Circuit B/D	kg	16,0	16,0	16,0	16,0	16,0	28,5	28,5	34,0	34,0	34,5	35,0	35,0
	tCO <sub>2</sub> e	10,8	10,8	10,8	10,8	10,8	19,2	19,2	23,0	23,0	23,3	23,6	23,6
<b>Oil</b>													
Circuit A/C	l	6,6	6,6	13,2	13,2	13,2	13,2	13,2	13,2	13,2	22,8	22,8	30,4
Circuit B/D	l	13,2	13,2	13,2	13,2	13,2	22,8	22,8	30,4	30,4	30,4	30,4	30,4
<b>Capacity control</b>		SmartVu™											
Minimum capacity	%	33	33	25	25	25	20	20	17	17	14	14	13
<b>Condenser</b>		Grooved copper tubes and aluminium fins											
<b>Fans</b>		Axial Flying Bird 6 with rotating impeller											
<b>Standard unit</b>													
Quantity		3	3	4	4	4	5	5	6	6	7	7	8
Maximum total air flow	l/s	14460	14460	19280	19280	19280	24100	24100	28920	28920	33740	33740	38560
Maximum rotation speed	r/s	16	16	16	16	16	16	16	16	16	16	16	16
<b>Evaporator</b>		Direct expansion brazed-plate heat exchanger											
Water volume	l	16,2	16,2	16,2	20,7	20,7	38,7	48,6	48,6	48,6	48,6	52,2	58,5
Max. water-side operating pressure without hydraulic module	kPa	1000	1000	1000	1000	1000	1000	1000	1000	1000	1000	1000	1000
<b>Hydraulic module (option)</b>		Pump, Victaulic screen filter, relief valve, water and air vent valve, pressure sensors											
Pump		Centrifugal pump, monocell, 48,3 r/s, low or high pressure (as required), single or dual (as required)											
Expansion tank volume (option)	l	50	50	50	50	50	80	80	80	80	80	80	80
Buffer tank volume (option)	l	550	550	550	550	550	550	550	550	550	550	550	550
Max. water-side operating pressure with hydraulic module	kPa	400	400	400	400	400	400	400	400	400	400	400	400
<b>Water connections with or without hydraulic module</b>		Victaulic® type											
Connections Module 1 / Module 2 <sup>(a)</sup>	inches	3	3	3	3	3	4	4	4	4	4	4	4
External diameter Module 1 / Module 2 <sup>(a)</sup>	mm	88,5	88,6	88,7	88,8	88,9	114,3	114,4	114,5	114,6	114,7	114,8	114,9
<b>Casing paintwork</b>		Colour code RAL 7035											

(4) Values are guidelines only. Refer to the unit name plate.

(a) Modules 1 and 2 only relate to sizes 620R to 1040R.

PHYSICAL DATA, SIZES 620R TO 1040R

30RQP		620R	660R	740R	800R	860R	940R	1040R
-------	--	------	------	------	------	------	------	-------

Heating

Standard unit Full load performances*	HA1	Nominal capacity	kW	635	673	774	812	883	935	1075
		COP	kW/kW	3,82	3,81	3,82	3,81	3,80	3,73	3,80
	HA2	Nominal capacity	kW	620	658	757	795	863	915	1052
		COP	kW/kW	3,10	3,09	3,10	3,09	3,10	3,03	3,10
Seasonal energy efficiency**	HA1	<b>SCOP</b> 30/35°C	<b>kWh/kWh</b>	<b>3,87</b>	<b>3,86</b>	<b>3,90</b>	<b>3,91</b>	<b>3,92</b>	<b>3,89</b>	<b>3,96</b>
		<b>ηs heat</b> 30/35°C	<b>%</b>	<b>152</b>	<b>151</b>	<b>153</b>	<b>153</b>	<b>154</b>	<b>153</b>	<b>155</b>
		P <sub>rated</sub>	kW	499	530	609	641	696	741	798

Cooling

Standard unit Full load performances*	CA1	Nominal capacity	kW	604	648	723	761	825	878	999
		EER	kW/kW	2,85	2,80	2,82	2,76	2,81	2,74	2,73
Seasonal energy efficiency**		SEER 12/7°C Comfort low temp.	kWh/kWh	4,78	4,81	4,88	4,87	4,81	4,75	4,81
		SEPR 12/7°C Process high temp.	kWh/kWh	5,49	5,34	5,60	5,40	5,60	5,43	5,47
Unit + option 15LS Full load performances*	CA1	Nominal capacity	kW	569	610	682	716	778	827	941
		EER	kW/kW	2,66	2,59	2,63	2,56	2,64	2,55	2,54
Seasonal energy efficiency**		SEER 12/7°C Comfort low temp.	kWh/kWh	4,73	4,76	4,91	4,78	4,94	4,86	4,75
		SEPR 12/7°C Process high temp.	kWh/kWh	5,51	5,37	5,62	5,39	5,65	5,47	5,52

Sound levels

Standard unit										
Sound power <sup>(1)</sup>		dB(A)	96,0	96,5	97,0	97,0	97,5	97,5	98,0	
Sound pressure at 10 m <sup>(2)</sup>		dB(A)	63,5	64,0	64,5	64,5	65,0	65,0	65,5	
Unit + option 15LS <sup>(3)</sup>										
Sound power <sup>(1)</sup>		dB(A)	91,0	91,0	92,0	92,0	92,5	93,0	93,0	
Sound pressure at 10 m <sup>(2)</sup>		dB(A)	58,5	58,5	59,5	59,5	60,0	60,5	60,5	

Dimensions - standard unit

Standard unit									
Length	mm	7708	7708	7708	7708	10096	10096	10096	
Width	mm	2253	2253	2253	2253	2253	2253	2253	
Height	mm	2324	2324	2324	2324	2324	2324	2324	

Unit + option 307<sup>(3)</sup>

Length	mm	-	-	-	-	-	-	-
--------	----	---	---	---	---	---	---	---

Operating weight<sup>(4)</sup>

Standard unit	kg	4787	4905	5344	5356	6308	6360	6859
Unit + option 15LS <sup>(3)</sup>	kg	5041	5158	5634	5646	6634	6686	7222
Unit + option 15LS + option 116W <sup>(3)</sup>	kg	5430	5548	6102	6114	7103	7229	7764
Unit + option 15LS + option 116W + option 307 <sup>(3)</sup>	kg	-	-	-	-	-	-	-

\* In accordance with EN14511-3:2022.

\*\* In accordance with EN14825:2022, average climate conditions

HA1 Heating mode conditions: Water type heat exchanger water inlet/outlet temperature 30 °C/35 °C, outside air temperature tdb/twb = 7 °C db/6 °C wb, evaporator fouling factor 0 m<sup>2</sup>. k/W

HA2 Heating mode conditions: Water type heat exchanger water inlet/outlet temperature 40 °C/45 °C, outside air temperature tdb/twb = 7 °C db/6 °C wb, evaporator fouling factor 0 m<sup>2</sup>. k/W

CA1 Cooling mode conditions: evaporator water inlet/outlet temperature 12 °C/7 °C, outdoor air temperature 35 °C, evaporator fouling factor 0 m<sup>2</sup>. k/W

**ηs heat 30/35°C & SCOP 30/35°C** Values in bold comply with Ecodesign Regulation (EU) No. 813/2013 for Heating applications

SEER 12/7 °C & SEPR 12/7 °C Applicable Ecodesign regulation (EU) No. 2016/2281.

(1) In dB ref=10<sup>-12</sup> W, (A) weighting. Declared dual-number noise emission value in accordance with ISO 4871 with an uncertainty of +/-3 dB(A). Measured in accordance with ISO 9614-1 and certified by Eurovent. Cooling mode.

(2) In dB ref 20 μPa, (A) weighting. Declared dual-number noise emission value in accordance with ISO 4871 with an uncertainty of +/-3 dB(A). For information, calculated from the sound power Lw(A).

(3) Options: 15LS = Very low noise level, 116W = Variable-speed high pressure dual-pump hydraulic module, 307 = Water buffer tank module,

(4) Values are guidelines only. Refer to the unit name plate.



Eurovent certified values

**PHYSICAL DATA, SIZES 620R TO 1040R**

30RQP		620R	660R	740R	800R	860R	940R	1040R
<b>Compressors</b>		Hermetic Scroll 48,3 r/s						
Circuit A/C		2/2	2/2	2/2	2/2	3/3	3/3	4/4
Circuit B/D		3/3	3/3	4/4	4/4	4/4	4/4	4/4
Number of power stages		10	10	12	12	14	14	16
<b>Unit PED category</b>		III	IV	IV	IV	IV	IV	IV
<b>Refrigerant<sup>(4)</sup></b>		R32 / A2L /GWP= 675 as per AR4						
Circuit A/C	kg	16,0 / 16,0	18,0 / 18,0	18,0 / 18,0	18,0 / 18,0	29,0 / 29,0	29,0 / 29,0	35,0 / 35,0
	tCO <sub>2</sub> e	10,8 / 10,8	12,2 / 12,2	12,2 / 12,2	12,2 / 12,2	19,6 / 19,6	19,6 / 19,6	23,6 / 23,6
Circuit B/D	kg	28,5 / 28,5	28,5 / 28,5	34,0 / 34,0	34,0 / 34,0	34,5 / 34,5	35,0 / 35,0	35,0 / 35,0
	tCO <sub>2</sub> e	19,2 / 19,2	19,2 / 19,2	23,0 / 23,0	23,0 / 23,0	23,3 / 23,3	23,6 / 23,6	23,6 / 23,6
<b>Oil</b>								
Circuit A/C	l	13,2 / 13,2	13,2 / 13,2	13,2 / 13,2	13,2 / 13,2	22,8 / 22,8	22,8 / 22,8	30,4 / 30,4
Circuit B/D	l	22,8 / 22,8	22,8 / 22,8	30,4 / 30,4	30,4 / 30,4	30,4 / 30,4	30,4 / 30,4	30,4 / 30,4
<b>Capacity control</b>		SmartVu™						
Minimum capacity	%	10	10	8	8	7	7	6
<b>Condenser</b>		Grooved copper tubes and aluminium fins						
<b>Fans</b>		Axial Flying Bird 6 with rotating impeller						
<b>Standard unit</b>								
Quantity		10	10	12	12	14	14	16
Maximum total air flow	l/s	48200	48200	57840	57840	67480	67480	77120
Maximum rotation speed	r/s	16	16	16	16	16	16	16
<b>Evaporator</b>		Direct expansion brazed-plate heat exchanger						
Water volume	l	77,4	97,2	97,2	97,2	97,2	104,4	117
Max. water-side operating pressure without hydraulic module	kPa	1000	1000	1000	1000	1000	1000	1000
<b>Hydraulic module (option)</b>		Pump, Victaulic screen filter, relief valve, water and air vent valve, pressure sensors						
Pump		Centrifugal pump, monocell, 48,3 r/s, low or high pressure (as required), single or dual (as required)						
Expansion tank volume (option)	l	-	-	-	-	-	-	-
Buffer tank volume (option)	l	-	-	-	-	-	-	-
Max. water-side operating pressure with hydraulic module	kPa	400	400	400	400	400	400	400
<b>Water connections with or without hydraulic module</b>		Victaulic® type						
Connections Module 1 / Module 2 <sup>(a)</sup>	inches	4 / 4	4 / 4	4 / 4	4 / 4	4 / 4	4 / 4	4 / 4
External diameter Module 1 / Module 2 <sup>(a)</sup>	mm	114,3 / 114,3	114,3 / 114,3	114,3 / 114,3	114,3 / 114,3	114,3 / 114,3	114,3 / 114,3	114,3 / 114,3
<b>Casing paintwork</b>		Colour code RAL 7035						

(4) Values are guidelines only. Refer to the unit name plate.

(a) Modules 1 and 2 only relate to sizes 620R to 1040R.



**ELECTRICAL DATA NOTES**

30RB		170R	190R	210R	230R	270R	310R	340R	380R	410R
<b>Power circuit supply</b>										
Nominal voltage	V-ph-Hz	400 - 3 - 50								
Voltage range	V	360 - 440								
<b>Control circuit supply</b>		24 V via internal transformer								
<b>Maximum operating input power <sup>(1) or (2)</sup></b>										
Circuit A&B	kW	74,6	81,2	90,8	99,4	118,6	133,9	148,3	163,5	178,4
<b>Power factor at maximum power <sup>(1) or (2)</sup></b>										
Standard unit power factor		0,83	0,83	0,83	0,83	0,83	0,83	0,83	0,83	0,85
<b>Maximum operating current draw (Un) <sup>(1) or (2)</sup></b>										
Standard unit	A	129,0	141,2	157,8	172,0	205,2	231,6	256,5	282,9	302,4
<b>Maximum current (Un-10%) <sup>(1) or (2)</sup></b>										
Standard unit	A	137,7	150,6	168,6	183,6	219,6	247,5	274,5	302,4	324
<b>Maximum start-up current (Un) <sup>(2) + (3)</sup></b>										
Standard unit	A	305	354	370	348	418	444	469	496	515
Unit + option 25/25E	A	262	302	318	305	366	392	417	444	463

30RB		450R	480R	550R	610R	670R	720R	770R	800R	870R	950R
<b>Power circuit supply</b>											
Nominal voltage	V-ph-Hz	400 - 3 - 50									
Voltage range	V	360 - 440									
<b>Control circuit supply</b>		24 V via internal transformer									
<b>Maximum operating input power <sup>(1) or (2)</sup></b>											
Circuit A&B	kW	193,7	208,1	237,8	256,4	282,7	306,1	328,5	340,2	374,4	405,6
<b>Power factor at maximum power <sup>(1) or (2)</sup></b>											
Standard unit power factor		0,85	0,85	0,85	0,84	0,84	0,84	0,84	0,84	0,84	0,84
<b>Maximum operating current draw (Un) <sup>(1) or (2)</sup></b>											
Standard unit	A	327,9	352,8	403,2	439,5	486,0	525,0	565,0	584,5	644,0	696,0
<b>Maximum current (Un-10%) <sup>(1) or (2)</sup></b>											
Standard unit	A	351	378	432	472	522	564	607	628	692	748
<b>Maximum start-up current (Un) <sup>(2) + (3)</sup></b>											
Standard unit	A	541	565	616	770	823	856	902	915	981	1027
Unit + option 25/25E	A	489	513	564	687	740	773	819	832	898	944

(1) Values at the unit's permanent maximum operating condition (as shown on the unit's nameplate).

(2) Values at the unit's maximum operating condition (as shown on the unit's nameplate).

(3) Maximum operating current of the smallest compressor(s) + fan current + locked rotor current of the largest compressor.

## ELECTRICAL DATA NOTES

30RBP		170R	190R	210R	230R	270R	310R	340R	380R	410R
<b>Power circuit supply</b>										
Nominal voltage	V-ph-Hz	400 - 3 - 50								
Voltage range	V	360 - 440								
<b>Control circuit supply</b>		24 V via internal transformer								
<b>Maximum operating input power <sup>(1) or (2)</sup></b>										
Circuit A&B	kW	74,8	81,5	91,1	99,8	118,9	134,3	148,7	164	178,4
<b>Power factor at maximum power <sup>(1) or (2)</sup></b>										
Standard unit power factor		0,85	0,85	0,85	0,85	0,85	0,85	0,85	0,85	0,85
<b>Maximum operating current draw (Un) <sup>(1) or (2)</sup></b>										
Standard unit	A	126,3	137,6	154,2	168,4	201,6	227,1	252,0	277,5	302,4
<b>Maximum current (Un-10%) <sup>(1) or (2)</sup></b>										
Standard unit	A	135	147	165	180	216	243	270	297	324
<b>Maximum start-up current (Un) <sup>(2) + (3)</sup></b>										
Standard unit	A	302	350	367	344	414	440	465	490	515
Unit + option 25/25E	A	259	298	315	301	362	388	413	438	463

30RBP		450R	480R	550R	610R	670R	720R	770R	800R	870R	950R
<b>Power circuit supply</b>											
Nominal voltage	V-ph-Hz	400 - 3 - 50									
Voltage range	V	360 - 440									
<b>Control circuit supply</b>		24 V via internal transformer									
<b>Maximum operating input power <sup>(1) or (2)</sup></b>											
Circuit A&B	kW	193,7	208,1	237,8	256,4	282,7	306,1	328,5	340,2	374,4	405,6
<b>Power factor at maximum power <sup>(1) or (2)</sup></b>											
Standard unit power factor		0,85	0,85	0,85	0,84	0,84	0,84	0,84	0,84	0,84	0,84
<b>Maximum operating current draw (Un) <sup>(1) or (2)</sup></b>											
Standard unit	A	327,9	352,8	403,2	439,5	486,0	525,0	565,0	584,5	644,0	696,0
<b>Maximum current (Un-10%) <sup>(1) or (2)</sup></b>											
Standard unit	A	351	378	432	472	522	564	607	628	692	748
<b>Maximum start-up current (Un) <sup>(2) + (3)</sup></b>											
Standard unit	A	541	565	616	770	823	856	902	915	981	1027
Unit + option 25/25E	A	489	513	564	687	740	773	819	832	898	944

(1) Values at the unit's permanent maximum operating condition (as shown on the unit's nameplate).

(2) Values at the unit's maximum operating condition (as shown on the unit's nameplate).

(3) Maximum operating current of the smallest compressor(s) + fan current + locked rotor current of the largest compressor.





**ELECTRICAL DATA NOTES**

30RQ		165R	180R	210R	230R	270R	310R	330R	370R	400R	430R	470R	520R
<b>Power circuit supply</b>													
Nominal voltage	V-ph-Hz	400 - 3 - 50											
Voltage range	V	360 - 440											
<b>Control circuit supply</b>													
24 V via internal transformer													
<b>Maximum operating input power <sup>(1) or (2)</sup></b>													
Circuit A&B	kW	74,6	84,2	99,4	109,0	118,6	138,7	148,3	168,3	177,9	193,2	207,6	237,2
<b>Power factor at maximum power <sup>(1) or (2)</sup></b>													
Standard unit power factor		0,83	0,83	0,83	0,83	0,83	0,83	0,83	0,83	0,83	0,83	0,83	0,83
<b>Maximum operating current draw (Un) <sup>(1) or (2)</sup></b>													
Standard unit	A	129	145,6	172	188,6	205,2	239,9	256,5	291,2	307,8	334,2	359,1	410,4
<b>Maximum current (Un-10%) <sup>(1) or (2)</sup></b>													
Standard unit	A	140,7	156,7	187,6	203,6	219,6	258,5	274,5	313,4	329,4	360,3	384,3	439,2
<b>Maximum start-up current (Un) <sup>(2) + (3)</sup></b>													
Standard unit	A	305	362	348	401	418	453	469	504	520	547	572	623
Unit + option 25/25E	A	262	310	305	349	366	401	417	452	468	495	520	571

30RQP		165R	180R	210R	230R	270R	310R	330R	370R	400R
<b>Power circuit supply</b>										
Nominal voltage	V-ph-Hz	400 - 3 - 50								
Voltage range	V	360 - 440								
<b>Control circuit supply</b>										
24 V via internal transformer										
<b>Maximum operating input power <sup>(1) or (2)</sup></b>										
Circuit A&B (Module 1 / Module 2) <sup>(a)</sup>	kW	74,8	84,4	99,8	109,3	118,9	139,2	148,7	169	178,6
<b>Power factor at maximum power <sup>(1) or (2)</sup></b>										
Standard unit power factor		0,85	0,85	0,85	0,85	0,85	0,85	0,85	0,85	0,85
<b>Maximum operating current draw (Un) <sup>(1) or (2)</sup></b>										
Standard unit (Module 1 / Module 2) <sup>(a)</sup>	A	126,3	142,9	168,4	185	201,6	235,4	252	285,8	302,4
<b>Maximum current (Un-10%) <sup>(1) or (2)</sup></b>										
Standard unit (Module 1 / Module 2) <sup>(a)</sup>	A	138	154	184	200	216	254	270	308	324
<b>Maximum start-up current (Un) <sup>(2) + (3)</sup></b>										
Standard unit (Module 1 / Module 2) <sup>(a)</sup>	A	302	359	344	398	414	448	465	498	515
Unit + option 25/25E (Module 1 / Module 2) <sup>(a)</sup>	A	259	307	301	346	362	396	413	446	463

30RQP		430R	470R	520R	620R	660R	740R	800R	860R	940R	1040R
<b>Power circuit supply</b>											
Nominal voltage	V-ph-Hz	400 - 3 - 50									
Voltage range	V	360 - 440									
<b>Control circuit supply</b>											
24 V via internal transformer											
<b>Maximum operating input power <sup>(1) or (2)</sup></b>											
Circuit A&B (Module 1 / Module 2) <sup>(a)</sup>	kW	193,9	208,3	237,8	139,2 / 139,2	148,7 / 148,7	169,0 / 169,0	178,6 / 178,6	193,7 / 193,7	208,1 / 208,1	237,8 / 237,8
<b>Power factor at maximum power <sup>(1) or (2)</sup></b>											
Standard unit power factor		0,85	0,85	0,85	0,85	0,85	0,85	0,85	0,85	0,85	0,85
<b>Maximum operating current draw (Un) <sup>(1) or (2)</sup></b>											
Standard unit (Module 1 / Module 2) <sup>(a)</sup>	A	327,9	352,8	403,2	235,4 / 235,4	252 / 252	285,8 / 285,8	302,4 / 302,4	327,9 / 327,9	352,8 / 352,8	403,2 / 403,2
<b>Maximum current (Un-10%) <sup>(1) or (2)</sup></b>											
Standard unit (Module 1 / Module 2) <sup>(a)</sup>	A	354	378	432	254 / 254	270 / 270	308 / 308	324 / 324	354 / 354	378 / 378	432 / 432
<b>Maximum start-up current (Un) <sup>(2) + (3)</sup></b>											
Standard unit (Module 1 / Module 2) <sup>(a)</sup>	A	541	565	616	448 / 448	465 / 465	498 / 498	515 / 515	541 / 541	565 / 565	616 / 616
Unit + option 25/25E (Module 1 / Module 2) <sup>(a)</sup>	A	489	513	564	396 / 396	413 / 413	446 / 446	463 / 463	489 / 489	513 / 513	564 / 564

(1) Values at the unit's permanent maximum operating condition (as shown on the unit's nameplate).  
 (2) Values at the unit's maximum operating condition (as shown on the unit's nameplate).  
 (3) Maximum operating current of the smallest compressor(s) + fan current + locked rotor current of the largest compressor.  
 (a) Modules 1 and 2 only relate to sizes 620R to 1040R.

PRESENTATION  
COOLING  
HEATING  
AIR TREATMENT  
CONTROLS

## ELECTRICAL DATA NOTES

### Short-circuit withstand current (TN system)<sup>(1)</sup>

30RB-RBP	170R	190R	210R	230R	270R	310R	340R	380R	410R	450R
<b>Rated short-circuit withstand currents</b>										
Rated short time (1s) current - I <sub>cw</sub> kA eff	5,5	8,5	8,5	8,5	8,5	20	20	20	20	20
Rated peak current - I <sub>pk</sub> kA pk	154	330	330	330	330	330	330	330	330	330
<b>Value with upstream electrical protection<sup>(1)</sup></b>										
Rated conditional short circuit current I <sub>cc</sub> kA eff	50	50	50	50	50	50	50	50	50	50
Associated protection	NSX160N / =S=	NSX250N / =S=	NSX250N / =S=	NSX250N / =S=	NSX250N / =S=	NSX250N / =S=	NSX400N / =S=	NSX400N / =S=	NSX400N / =S=	NSX400N / =S=
Associated protection	TM160D / LV430840	TM200D / LV431831	TM200D / LV431831	TM250D / LV431831	TM250D / LV431831	TM250D / LV431831	Micrologic 2,3 400 A / LV432693	Micrologic 2,3 400 A / LV432693	Micrologic 2,3 400 A / LV432693	Micrologic 2,3 400 A / LV432693

30RB-RBP	480R	550R	610R	670R	720R	770R	820R	870R	950R
<b>Rated short-circuit withstand currents</b>									
Rated short time (1s) current - I <sub>cw</sub> kA eff	20	20	20	20	20	35	35	35	35
Rated peak current - I <sub>pk</sub> kA pk	330	330	330	330	330	330	330	330	330
<b>Value with upstream electrical protection<sup>(1)</sup></b>									
Rated conditional short circuit current I <sub>cc</sub> kA eff	50	50	50	50	50	50	50	50	50
Associated protection	NSX630N / =S=	NSX630N / =S=	NSX630N / =S=	NSX630N / =S=	NSX630N / =S=	NS800 / =S=	NS800 / =S=	NS800 / =S=	NS800 / =S=
Associated protection	Micrologic 2,3 630 A / LV432893	Micrologic 2,3 630 A / LV432893	Micrologic 2,3 630 A / LV432893	Micrologic 2,3 630 A / LV432893	Micrologic 2,3 630 A / LV432893	Micrologic 5,0 800 A / 34426	Micrologic 5,0 800 A / 34426	Micrologic 5,0 800 A / 34426	Micrologic 5,0 800 A / 34426

(1) If another current limitation protection device is used, its time-current and thermal constraint (I<sup>2t</sup>) trip characteristics must be at least equivalent to those of the recommended protection.

**Note: The short-circuit withstand current capability values above have been established for the TN system.**



**ELECTRICAL DATA NOTES**

30RQ-RQP	165R	180R	210R	230R	270R	310R	330R	370R	400R	430R	
<b>Rated short-circuit withstand currents</b>											
Rated short time (1s) current - I <sub>cw</sub> (Module 1 / Module 2) <sup>(a)</sup>	kA eff	5,5	8,5	8,5	8,5	8,5	20	20	20	20	
Rated peak current - I <sub>pk</sub> (Module 1 / Module 2) <sup>(a)</sup>	kA pk	154	330	330	330	330	330	330	330	330	
<b>Value with upstream electrical protection<sup>(1)</sup></b>											
Rated conditional short circuit current I <sub>cc</sub> (Module 1 / Module 2) <sup>(a)</sup>	kA eff	50	50	50	50	50	50	50	50	50	
Associated protection - type (Module 1/Module 2) <sup>(a)</sup>		INS250	INS250	INS250	INS250	INS250	INS400	INS400	INS400	INS400	
Associated protection (rating/reference)	Module 1 <sup>(a)</sup>	TM160D / LV430840	TM200D / LV431831	TM250D / LV431831	TM250D / LV431831	TM250D / LV431831	Micrologic 2,3 400 A / LV432693	Micrologic 2,3 400 A / LV432693	Micrologic 2,3 400 A / LV432693	Micrologic 2,3 400 A / LV432693	Micrologic 2,3 400 A / LV432693
	Module 2 <sup>(a)</sup>	-	-	-	-	-	-	-	-	-	

30RQ-RQP	470R	520R	620R	660R	740R	800R	860R	940R	1040R	
<b>Rated short-circuit withstand currents</b>										
Rated short time (1s) current - I <sub>cw</sub> (Module 1 / Module 2) <sup>(a)</sup>	kA eff	20	20	20 / 20	20 / 20	20 / 20	20 / 20	20 / 20	20 / 20	
Rated peak current - I <sub>pk</sub> (Module 1 / Module 2) <sup>(a)</sup>	kA pk	330	330	330 / 330	330 / 330	330 / 330	330 / 330	330 / 330	330 / 330	
<b>Value with upstream electrical protection<sup>(1)</sup></b>										
Rated conditional short circuit current I <sub>cc</sub> (Module 1 / Module 2) <sup>(a)</sup>	kA eff	50	50	50 / 50	50 / 50	50 / 50	50 / 50	50 / 50	50 / 50	
Associated protection - type (Module 1/Module 2) <sup>(a)</sup>		INS500	INS500	INS400 / INS400	INS400 / INS400	INS400 / INS400	INS400 / INS400	INS400 / INS400	INS500 / INS500	
Associated protection (rating/reference)	Module 1 <sup>(a)</sup>	Micrologic 2,3 630 A / LV432893	Micrologic 2,3 630 A / LV432893	Micrologic 2,3 400 A / LV432693	Micrologic 2,3 400 A / LV432693	Micrologic 2,3 400 A / LV432693	Micrologic 2,3 400 A / LV432693	Micrologic 2,3 400 A / LV432693	Micrologic 2,3 630 A / LV432893	Micrologic 2,3 630 A / LV432893
	Module 2 <sup>(a)</sup>	-	-	Micrologic 2,3 400 A / LV432693	Micrologic 2,3 400 A / LV432693	Micrologic 2,3 400 A / LV432693	Micrologic 2,3 400 A / LV432693	Micrologic 2,3 400 A / LV432693	Micrologic 2,3 630 A / LV432893	Micrologic 2,3 630 A / LV432893

(1) If another current limitation protection device is used, its time-current and thermal constraint (I<sup>2</sup>t) trip characteristics must be at least equivalent to those of the recommended protection.

(a) Modules 1 and 2 only relate to sizes 620R to 1040R.

**Note: The short-circuit withstand current capability values above have been established for the TN system.**

PRESENTATION  
COOLING  
HEATING  
AIR TREATMENT  
CONTROLS



## DIMENSIONS/CLEARANCES

### 30RB/30RBP 170R-270R, 30RQ/30RQP 165R-270R (with and without hydraulic module)

#### Without hydraulic module

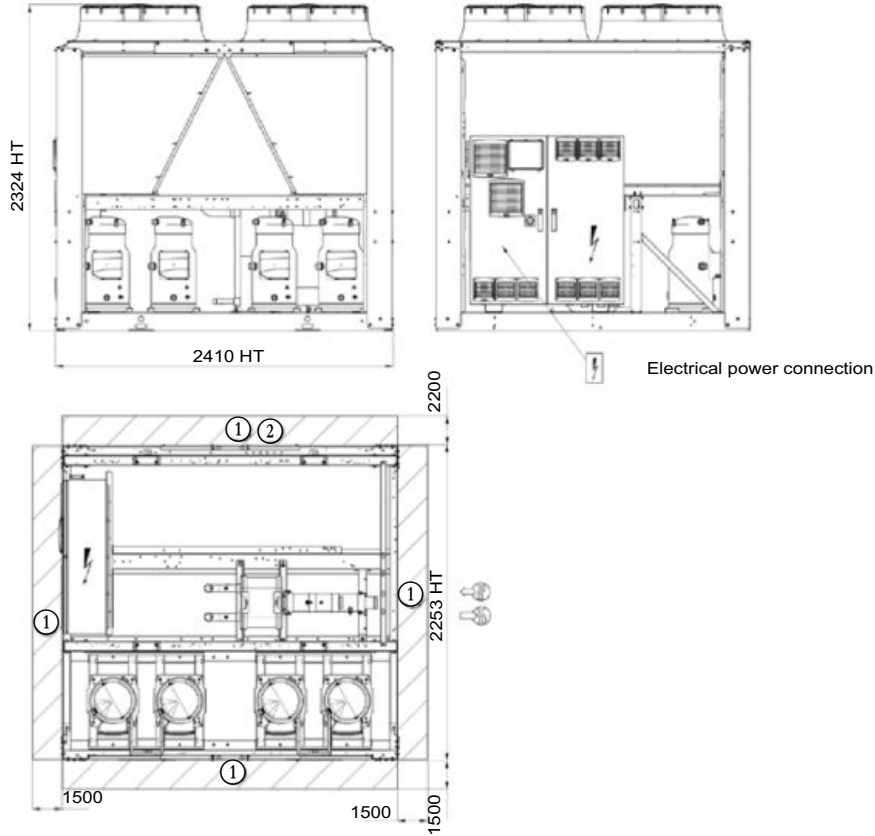

#### With hydraulic module

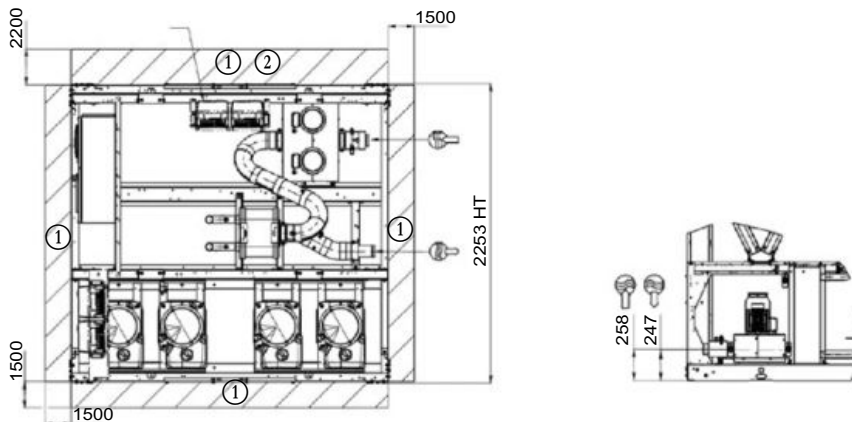

#### Key:

All dimensions are given in mm.

- ① Clearances required for maintenance and air flow
- ② Clearance recommended for removal of the coils
- Water inlet
- Water outlet
- Air outlet, do not obstruct
- Electrical cabinet

**Note: Drawings are not contractually binding. Before designing an installation, consult the certified dimensional drawings, available on request.**

**Refer to the certified dimensional drawings for the location of fixing points, weight distribution and coordinates of the centre of gravity.**



## DIMENSIONS/CLEARANCES

### 30RB/30RBP 310R-410R, 30RQ/30RQP 310R-400R (with and without hydraulic module)

#### Without hydraulic module

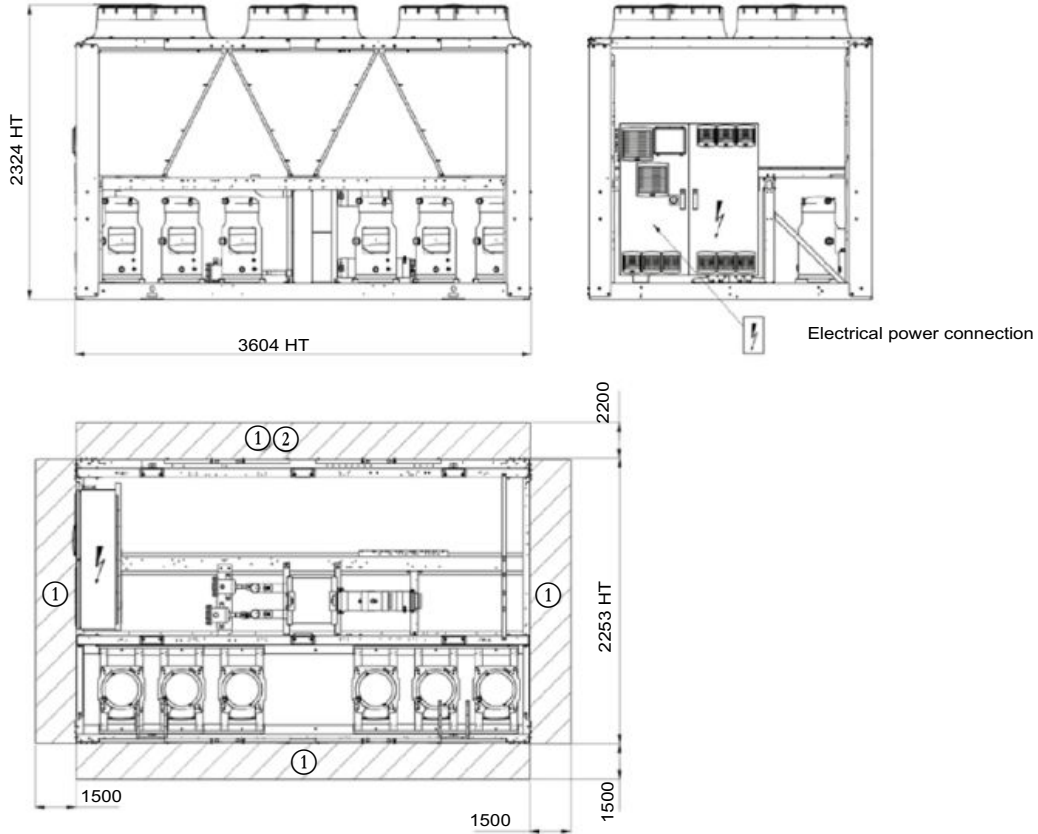

#### With hydraulic module

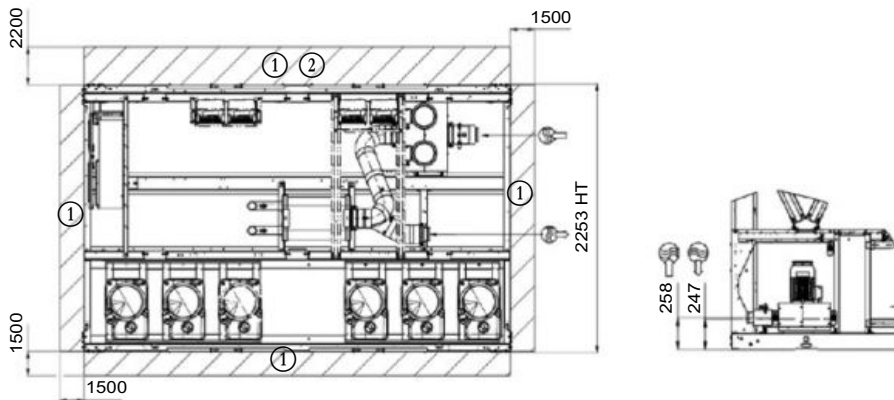

**Key:**

All dimensions are given in mm.

- ① Clearances required for maintenance and air flow
- ② Clearance recommended for removal of the coils
- Water inlet
- Water outlet
- Air outlet, do not obstruct
- Electrical cabinet

**Note:** Drawings are not contractually binding. Before designing an installation, consult the certified dimensional drawings, available on request.

Refer to the certified dimensional drawings for the location of fixing points, weight distribution and coordinates of the centre of gravity.





## DIMENSIONS/CLEARANCES

### 30RB/30RBP 450R-550R, 30RQ/30RQP 430R-520R (with and without hydraulic module)

#### Without hydraulic module

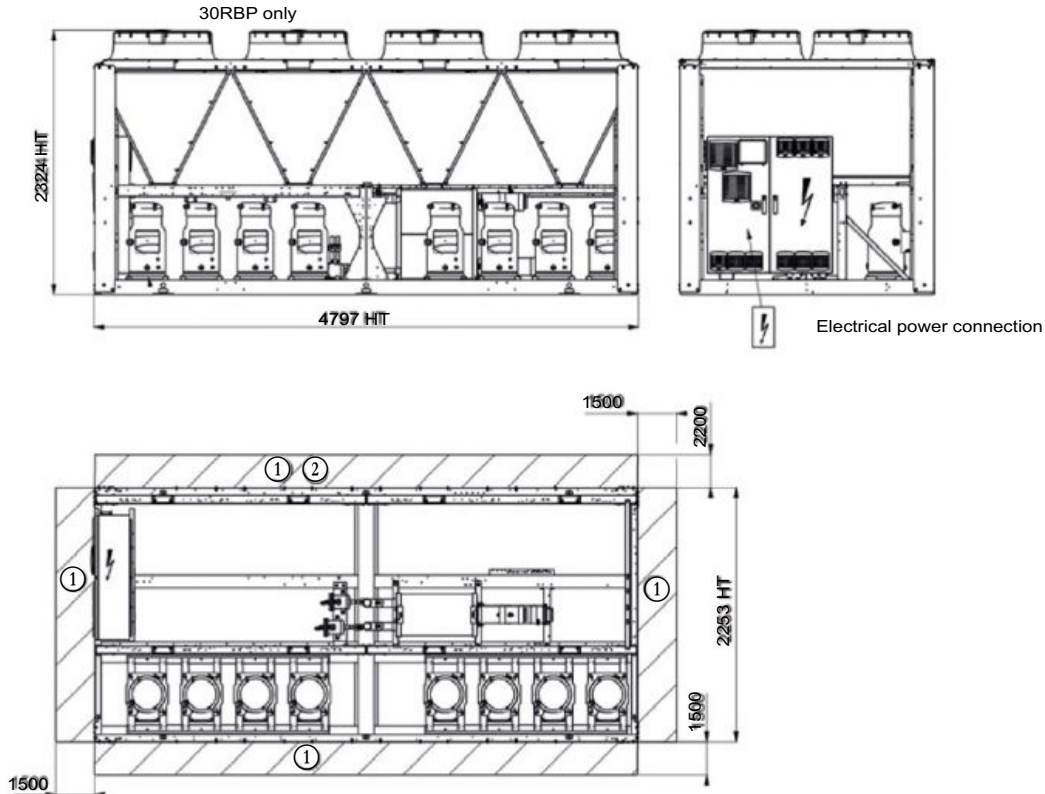

#### With hydraulic module

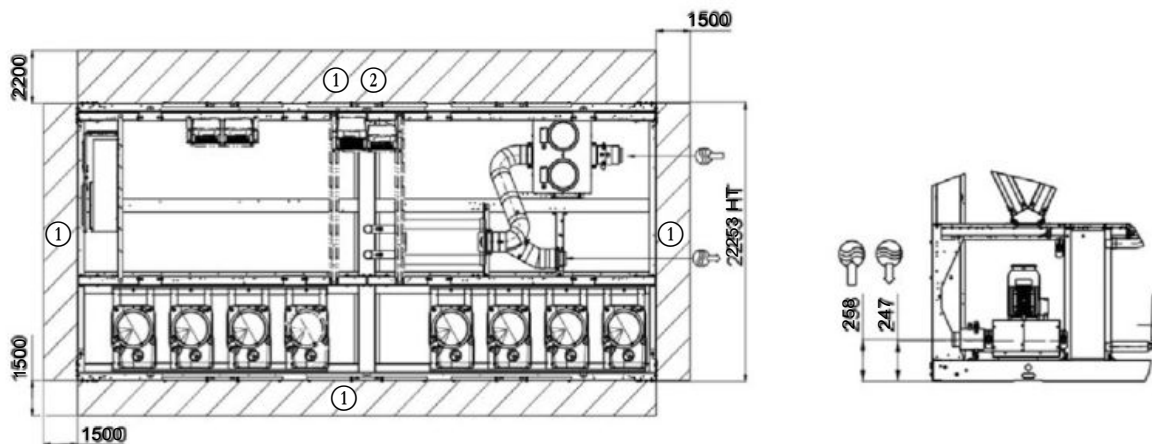

#### Key:

All dimensions are given in mm.

- ① Clearances required for maintenance and air flow
- ② Clearance recommended for removal of the coils

Water inlet

Water outlet

Air outlet, do not obstruct

Electrical cabinet

**Note: Drawings are not contractually binding. Before designing an installation, consult the certified dimensional drawings, available on request.**

**Refer to the certified dimensional drawings for the location of fixing points, weight distribution and coordinates of the centre of gravity.**



## DIMENSIONS/CLEARANCES

### 30RB/30RBP 610R-720R (with and without hydraulic module)

#### Without hydraulic module

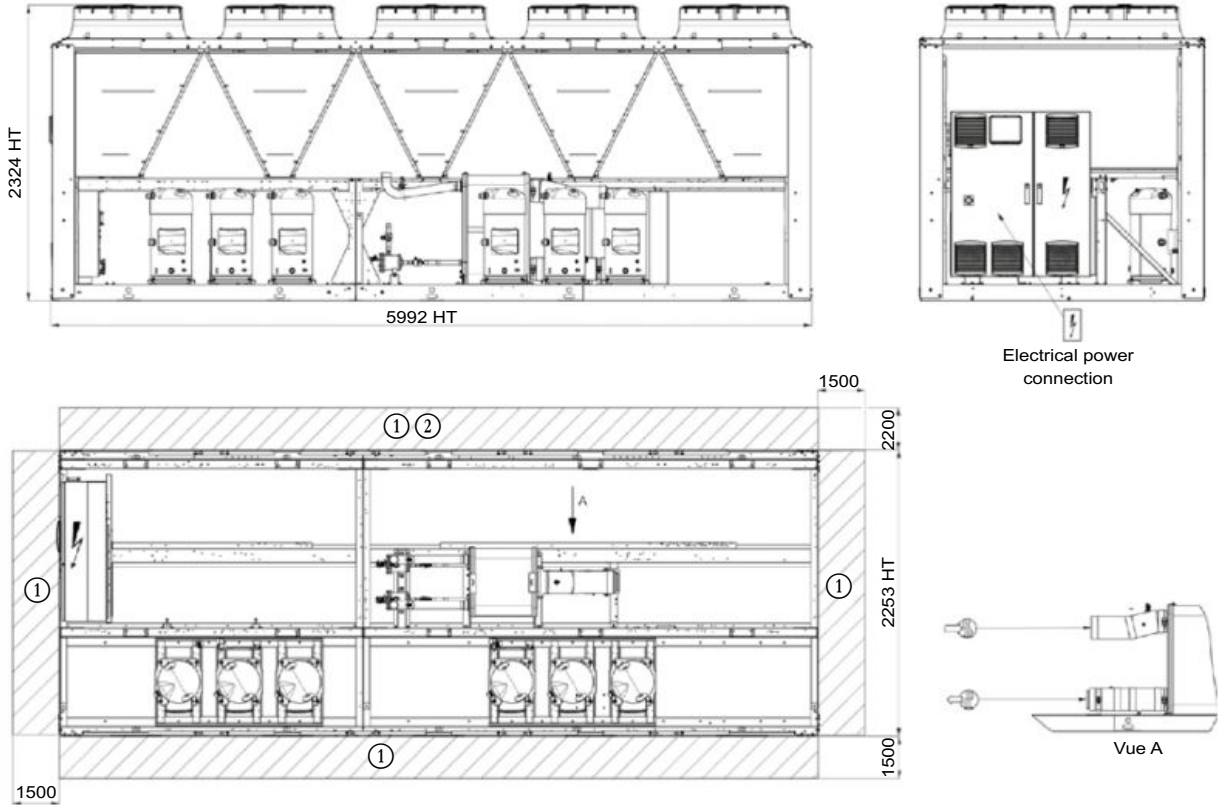

#### With hydraulic module

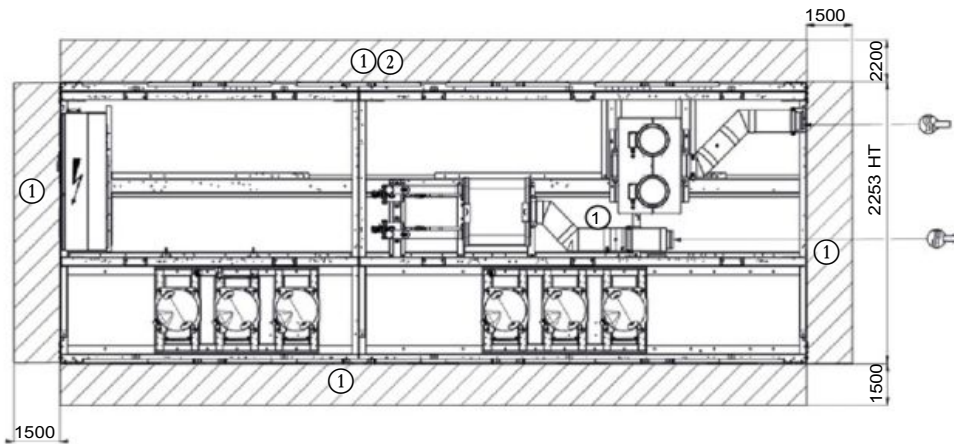

**Key:**

All dimensions are given in mm.

- ① Clearances required for maintenance and air flow
- ② Clearance recommended for removal of the coils

- Water inlet
- Water outlet
- Air outlet, do not obstruct
- Electrical cabinet

**Note:** Drawings are not contractually binding. Before designing an installation, consult the certified dimensional drawings, available on request.

Refer to the certified dimensional drawings for the location of fixing points, weight distribution and coordinates of the centre of gravity.



## DIMENSIONS/CLEARANCES

### 30RB/30RBP 770R-950R (with and without hydraulic module)

#### Without hydraulic module

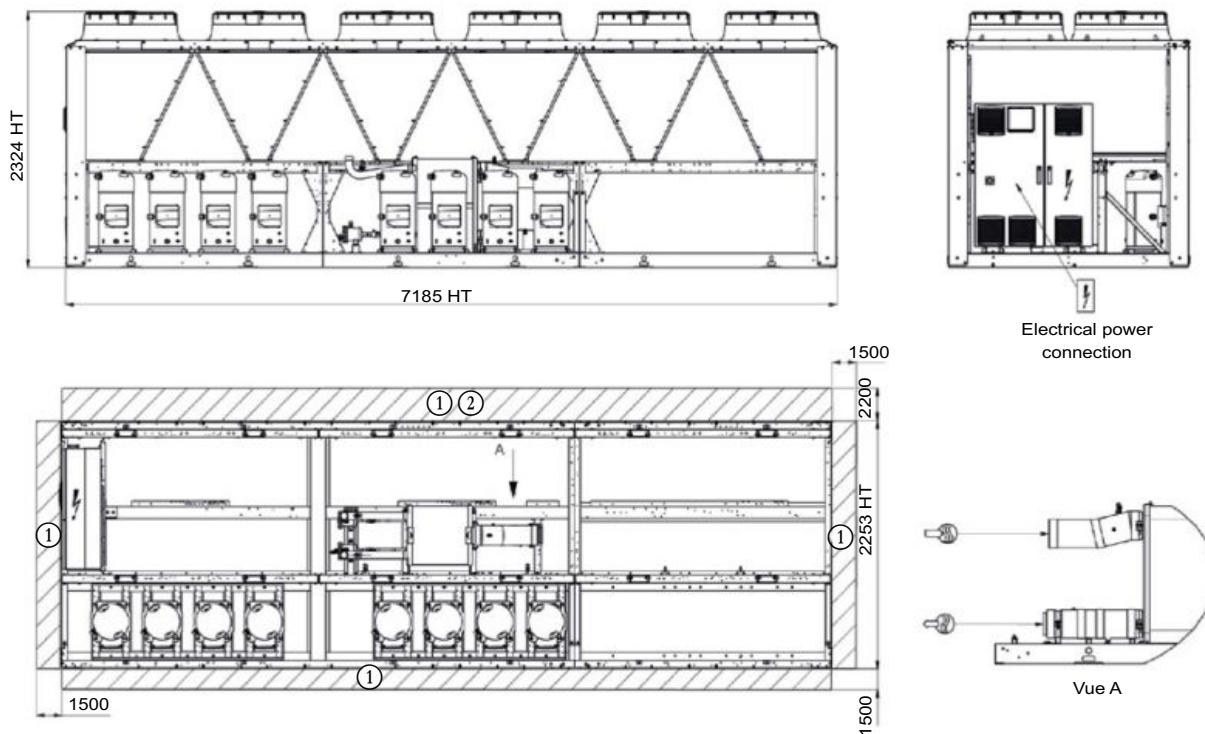

#### With hydraulic module

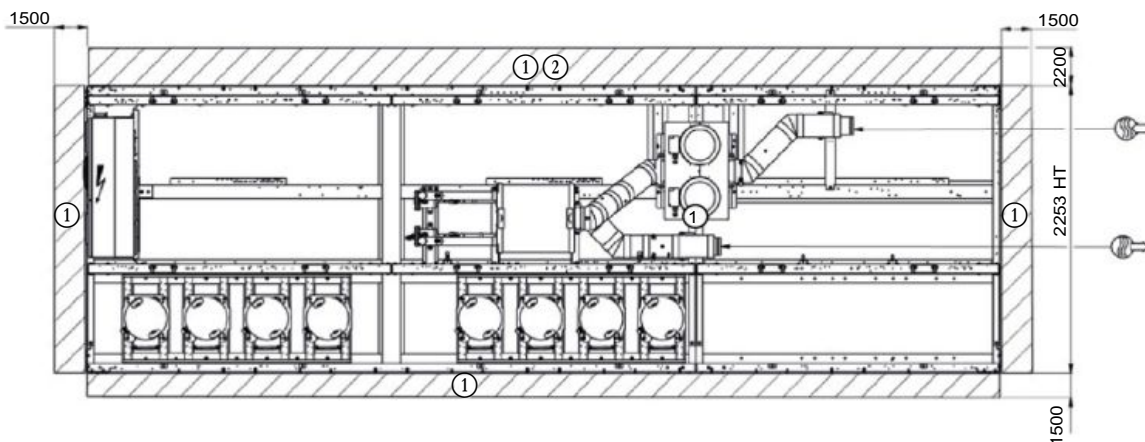

#### Key:

All dimensions are given in mm.

① Clearances required for maintenance and air flow

② Clearance recommended for removal of the coils

Water inlet

Water outlet

Air outlet, do not obstruct

Electrical cabinet

**Note: Drawings are not contractually binding. Before designing an installation, consult the certified dimensional drawings, available on request.**

**Refer to the certified dimensional drawings for the location of fixing points, weight distribution and coordinates of the centre of gravity.**





## DIMENSIONS/CLEARANCES

### 30RQP 620R-1040R (with and without hydraulic module)

#### Without hydraulic module

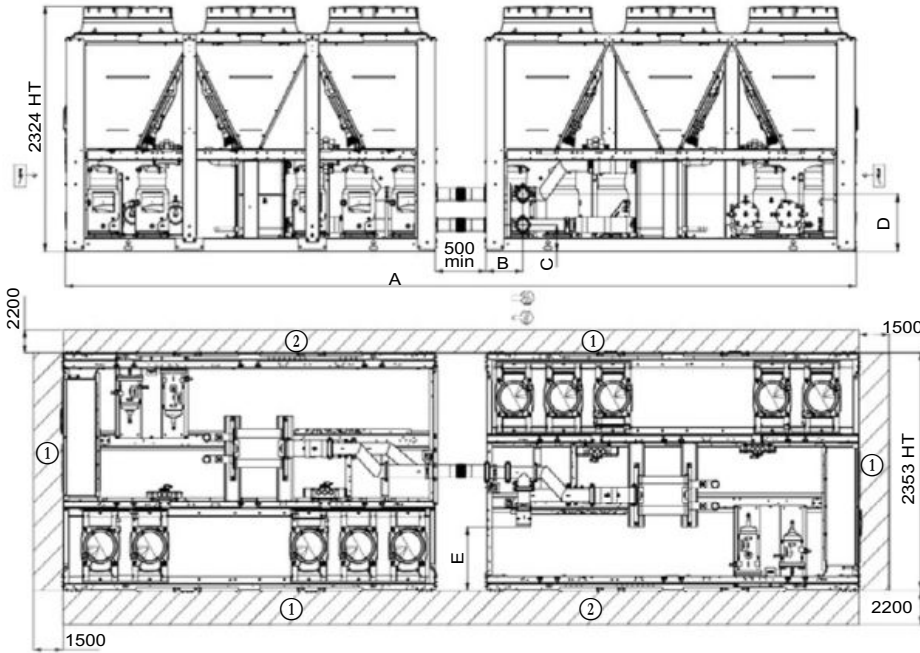

30RQP	620R to 800R	860R to 1040R
Length A (mm)	7680	10068
Length B (mm)	357	357
Length C (mm)	251	251
Length D (mm)	544	544
Length E (mm)	597	597
Victaulic	5"	5"

#### With hydraulic module

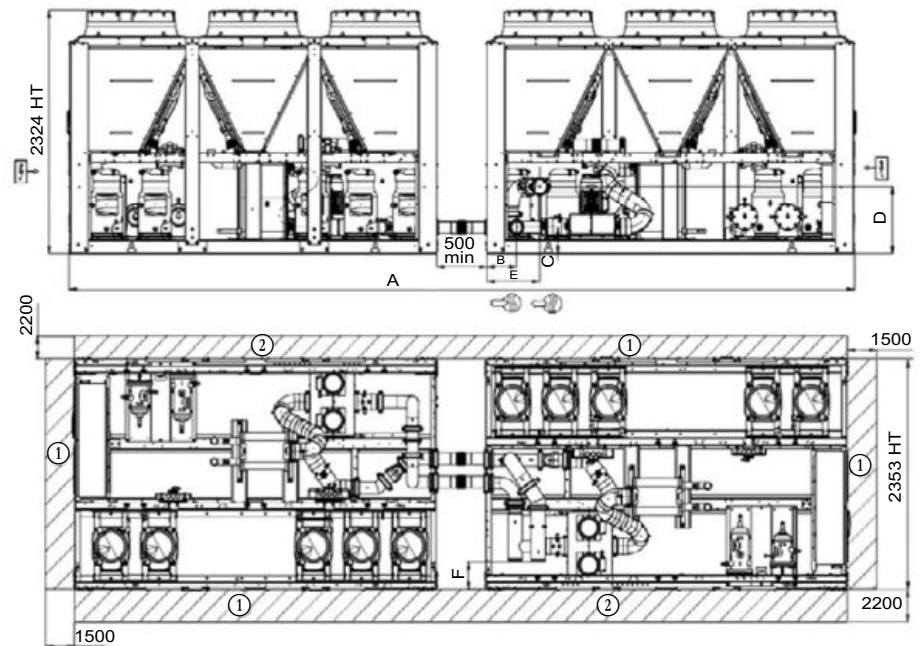

30RQP	620R to 800R	860R to 1040R
Length A (mm)	7680	10068
Length B (mm)	290	251
Length C (mm)	254	254
Length D (mm)	640	640
Length E (mm)	516	509
Length F (mm)	265	265
Victaulic	5"	5"

**Key:**

All dimensions are given in mm.

- ① Clearances required for maintenance and air flow
- ② Clearance recommended for removal of the coils

- Water inlet
- Water outlet
- Air outlet, do not obstruct
- Electrical cabinet

**Note: Drawings are not contractually binding. Before designing an installation, consult the certified dimensional drawings, available on request.**

**Refer to the certified dimensional drawings for the location of fixing points, weight distribution and coordinates of the centre of gravity.**

## WATER-SOURCED HEAT PUMPS



61WG optimized for heating  
Compact design  
Plug and play approach  
High efficiency

## 61WG-A



Nominal heating capacity 29-230 kW  
Nominal cooling capacity 25-190 kW

The 61WG units are new Carrier chillers and heat pumps designed for commercial (offices, small hotels, leisure facilities), residential and industrial applications. All units offer a unique combination of high performance and functionality in an exceptionally compact chassis.

61WG units are designed for high-temperature heating applications with hot water production possible up to 65 °C.

A large number of options is available for the whole range:

- hydraulic modules with or without variable water flow rate,
- reinforced sound insulation,
- stacking and connection of two units



CARRIER participates in the ECP programme for LCP-HP  
Check ongoing validity of certificate:  
[www.eurovent-certification.com](http://www.eurovent-certification.com)



## CUSTOMER BENEFITS

### Features

- Reduced footprint
- Scroll compressors and R-410A refrigerant
- Variable-flow pump
- Low-noise option (-3 dB(A))
- Stacking of two units for increased capacity (up to size 090)
- Several communication protocols available: JBus, BacNet, MS/TP, LON
- Water connection at the top or rear (61WG only)

### Available versions

#### 61WG - optimised for heating

- High temperature up to +65 °C
- Evaporator temperature down to -5 °C
- Control of the three-way diverter valve for domestic hot water and space heating requirements
- System approach - the Heating System Manager maximises the global efficiency of complex systems where the 61WG units are combined with an auxiliary heating source to serve multi-zone space heating and domestic hot water production.

#### The right unit for any application

- The high temperature of the 61WG units makes them compatible with most heating systems, both in new and refurbished buildings and permits domestic hot water production (with a dedicated temperature setpoint).
- Option 153 "Built-in DHW and space heating control" allows control of both domestic hot water and space heating requirements:
  - Domestic hot water production: a built-in three-way valve is directed to divert the heat flow from the space heating loop to the domestic hot water loop and vice versa.
  - Space heating control: the setpoint is adjustable, based on the daily schedule or the outside air temperature (weather compensation function).
  - Control of auxiliary systems: if an alarm is detected at the or if there is insufficient heating capacity, a digital signal starts an auxiliary electric heater (1 to 4 stages) or boiler.
  - Pump control: allows control of the built-in pump as well as the pump in the secondary loop (to terminals).

- In 61WG units the Heating System Manager (HSM) accessory allows control of systems with several heat sources and different additional systems: electric heat, boiler or for the most complex systems district heating (see pages 9 to 11).

#### Adaptability and simple installation

- The 61WG units can be provided with several hydraulic module options, both on the evaporator and/or condenser side, with different levels of available pressure and variable or fixed-speed pumps (see page 7).
- If option 153 is selected domestic hot water production is controlled via a built-in three-way diverter valve (not supplied).
- 61WG units offer water-side cooling/heating reversibility.

#### Water connections at the rear of the unit



#### Internal view of 61WG unit with hydraulic module



## CUSTOMER BENEFITS

### Water connections at the top of the unit



### Component accessibility

See photos below.

#### Access to scroll compressors



#### Access to control panel



### A compact high-performance product range

- Small footprint, ideal for refurbished buildings, allows access in very tight plant rooms.
- 61WG: High SCOP satisfies even the most stringent standards, with a leaving water temperature of up to 65 °C without supplementary system.
- Units optimized for process and comfort applications.
- Variable-flow pumps reduce system energy consumption.
- The entire range offers low sound levels, allowing installation in any building type. The low-noise option ensures enhanced acoustic comfort (-3 dB(A)).
- 61WG units are equipped with the latest generation R410A scroll compressor, optimised for typical operating conditions for water-sourced units.

### Two-unit stacking option for reduced footprint size 020-090

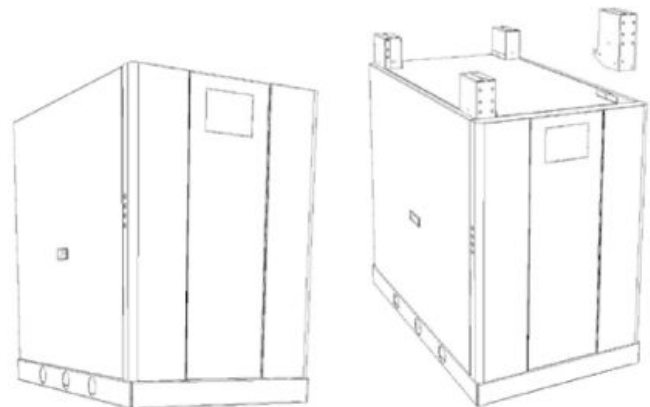

## CUSTOMER BENEFITS

### SmartVu™ control

The SmartVu™ control combines intelligence with operating simplicity. The control constantly monitors all machine parameters and precisely manages the operation of compressors, expansion devices, fans and the evaporator water pump for optimum energy efficiency.

The SmartVu™ control features advanced communication technology over Ethernet (IP) and a user-friendly and intuitive user interface with 4.3-inch colour touch screen.

- Energy management configuration
  - Internal timer: controls chiller on/off times and operation at a second setpoint
  - Setpoint offset based on the outdoor air temperature
  - Master/slave control of two chillers operating in parallel with runtime balancing and automatic changeover in case of a unit fault.
  - Innovative smart energy monitoring, providing users with smart data such as real-time electrical energy consumption and cooling capacity, and instantaneous and average energy efficiency values.
  - For further energy savings, the AquaSnap® can be monitored remotely by Carrier experts for energy consumption diagnosis and optimisation.
- Integrated features
  - Night mode: Capacity and fan speed limitation for reduced noise level
  - With hydraulic module: Water pressure display and water flow rate calculation.
- Advanced communication features
  - Easy and high-speed communication technology over Ethernet (IP) to a centralised building management system
  - Access to multiple unit parameters.
- Maintenance functions
  - F-Gas regulation leak check reminder alert
  - Maintenance alert can be configured to days, months or hours of operation
  - Display of trend curves for the main values
  - Management of a fault memory allowing a log of the last 50 incidents to be accessed, with operating readings taken when the fault occurs
  - Blackbox memory

- 4"3 SmartVu™ user interface

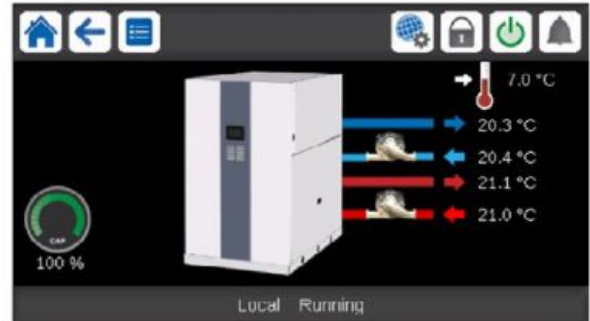

- Intuitive and user-friendly 4"3 inch touch screen interface
- Concise and clear information is available in local languages
- Complete menu, customised for different users (end user, service personnel or Carrier engineers).

### Remote management (standard)

Units with SmartVu™ control can be easily accessed from the internet, using a PC with an Ethernet connection. This makes remote control quick and easy and offers significant advantages for service operations.

The AquaSnap® is equipped with an RS485 serial port that offers multiple remote control, monitoring and diagnostic possibilities. Carrier offers a vast choice of control products, specially designed to control, manage and supervise the operation of an air conditioning system. Please consult your Carrier representative for more information.

The AquaSnap® also communicates with other centralised building management systems via optional communication gateways.

A connection terminal allows the AquaSnap® unit to be remotely controlled by wire:

- Start/stop: Opening of this contact will shut down the unit
- Dual setpoint: closing of this contact activates a second setpoint (e.g.: unoccupied mode).
- Demand limit: Closing of this contact limits the maximum chiller capacity to a predefined value.
- Operation indication: This volt-free contact indicates that the chiller is operating (cooling load).
- Alarm indication: this volt-free contact indicates the presence of a major fault that has led to the shut-down of one or several refrigerant circuits.

## OPTIONS

Options	No.	Description	Advantages	Use
Soft Starter	25	Electronic starter on each compressor	Reduced start-up current	61WG 020-190
Master/slave operation	58	Unit equipped with supplementary water outlet temperature sensor kit to be field-installed allowing master/slave operation of two units connected in parallel	Optimised operation of two units connected in parrallele operation with operating time equalisation	61WG 020-190
External disconnect handle	70F	The handle of the electrical disconnect switch is on the outside of the unit	Quick access to the unit disconnect switch	61WG 020-190
Evap. single pump power/control circuit	84	Unit equipped with an electrical power and control circuit for one pump evaporator side	Quick and easy installation: the control of fixed speed pumps is embedded in the unit control	61WG 110-190
Cond. single pump power/control circuit	84R	Unit equipped with an electrical power and control circuit for one pump condenser side	Quick and easy installation: the control of fixed speed pumps is embedded in the unit control	61WG 110-190
Condenser insulation	86	Thermal condenser insulation	Minimizes thermal dispersions condenser side (key option for heat pump or heat recovery applications) and allows compliancy with special installation criteria (hot parts insulated)	61WG 020-190
HP single-pump hydraulic module	116R	Single high-pressure water pump, water filter, electronic water flow control, pressure transducers. For more details, refer to the dedicated chapter (expansion tank not included.Option with built-in safety hydraulic components available.)	Easy and fast installation (plug & play)	61WG 110-190
LP evap. single-pump	116T	Evaporator hydraulic module equipped with low pressure fixed-speed pump, drain valve, air vent and pressure sensors. For more details, refer to the dedicated chapter (expansion tank not included.Option with built-in safety hydraulic components available.)	Easy and fast installation (plug & play)	61WG 020-190
HP evap. variable-speed single-pump	116V	Evaporator hydraulic module equipped with high-pressure variable-speed pump, drain valve, air vent and pressure sensors. For more details, refer to the dedicated chapter (expansion tank not included.Option with built-in safety hydraulic components available.)	Easy and fast installation (plug & play), significant pumping energy cost savings (more than two-thirds), tighter water flow control, improved sytem reliability	61WG 020-190
HP VSD dual-pump hydraulic mod.	116W	Dual high-pressure water pump with variable speed drive (VSD), pressure transducers. Multiple possibilities of water flow control. For more details, refer to the dedicated chapter (expansion tank not included Option with built-in safety hydraulic components available)	Easy and fast installation (plug & play), significant pumping energy cost savings (more than two-thirds), tighter water flow control, improved sytem reliability	61WG 110-190
LP VSD single-pump	116Y	Evaporator hydraulic module equipped with low -pressure variable-speed pump, drain valve, air vent and pressure sensors. For more details, refer to the dedicated chapter (expansion tank not included.Option with built-in safety hydraulic components available.)	Easy and fast installation (plug & play), significant pumping energy cost savings (more than two-thirds), tighter water flow control, improved sytem reliability	61WG 110-190
Lon gateway	148D	Two-directional communication board complying with Lon Talk protocol	Connects the unit by communication bus to a building management system	61WG 020-190
Bacnet over IP	149	Two-directional high-speed communication using BACnet protocol over Ethernet network (IP)	Easy and high-speed connection by ethernet line to a building management system. Allows access to multiple unit parameters	61WG 020-190
Modbus over IP and RS485	149B	Bi-directional high-speed communication using Modbus protocol over Ethernet network (IP)	Easy and high-speed connection by ethernet line to a building management system. Allows access to multiple unit parameters	61WG 020-190

## OPTIONS

Options	No.	Description	Advantages	Use
Built-in DHW & space heating control	153	Control board factory-installed on the unit, control using weather compensation, control of supplementary electric heater (4 stages) or boiler, needle valve for domestic hot-water production with programmable time schedule.	Permits easy control of a basic heating system	61WG 020-090
Compliance with Russian regulations	199	EAC certification	Conformance with Russian regulations	61WG 020-190
Insulation of the evap. in/out ref.lines	256	Thermal insulation of the evaporator entering/leaving refrigerant lines with flexible, anti-UV insulant	Prevents condensation on the evaporator entering/leaving refrigerant lines	61WG 020-190
Low noise level	257	Compressor sound enclosure	Reduced sound emissions	61WG 020-190
Very low sound level	258	Enhanced sound insulation of main noise sources (Material classified CD0S2 fire class according to Euroclass 13-501).	6 dB(A) quieter than standard . Refer to the physical data table for detailed values	61WG 020-090
Evaporator screw connection sleeves kit	264	Evaporator inlet/outlet screw connection sleeves	Allows unit connection to a screw connector	61WG 020-140
Condenser screw connection sleeves kit	265	Condenser inlet/outlet screw connection sleeves	Allows unit connection to a screw connector	61WG 020-140
Welded evaporator connection kit	266	Victaulic piping connections with welded joints	Easy installation	61WG 020-190
Welded condenser water connection kit	267	Victaulic piping connections with welded joints	Easy installation	61WG 020-190
HP single-pump, cond. side	270R	Condenser hydraulic module equipped with high pressure fixed-speed pump, drain valve, air vent and pressure sensors. Built-in safety hydraulic components available in option.	Easy and fast installation (plug & play)	61WG 110-190
LP single-pump, cond. side	270T	Condenser hydraulic module equipped with low pressure fixed-speed pump, drain valve, air vent and pressure sensors. Built-in safety hydraulic components available in option.	Easy and fast installation (plug & play)	61WG 020-190
HP cond. variable-speed single-pump	270V	Condenser hydraulic module equipped with high-pressure variable-speed pump, drain valve, air vent and pressure sensors. (expansion tank not included) Built-in safety hydraulic components available in option.	Easy and fast installation (plug & play), reduced power consumption of the water circulation pump	61WG 020-190
HP cond. variable-speed dual-pump	270W	Condenser hydraulic module equipped with dual high-pressure variable-speed pump, drain valve, air vent and pressure sensors. (expansion tank not included) Built-in safety hydraulic components available in option.	Easy and fast installation (plug & play), reduced power consumption of the water circulation pump	61WG 110-190
LP cond. variable-speed single-pump	270Y	Condenser hydraulic module equipped with low-pressure variable-speed pump, drain valve, air vent and pressure sensors. (expansion tank not included) Built-in safety hydraulic components available in option.	Easy and fast installation (plug & play), reduced power consumption of the water circulation pump	61WG 110-190
High-temp. water prod. with glycol solution on the evap.	272	Condenser side water production up to 65 °C, with glycol solution on the evaporator side to -5 °C	Geothermal application and domestic hot-water production	61WG 020-190
Unit stackable for operation	273	Unit stackable for operation	Reduced footprint size	61WG 020-090
water connection at the top	274	Customer water connection at the top of the unit	Reduced footprint size	61WG 020-190
Safety hydraulic components, evap. side	293	Screen filter, expansion tank and relief valve integrated in the evaporator hydraulic module	Easy and fast installation (plug & play), operating safety	61WG 020-190
Safety hydraulic components, cond. side	293A	Screen filter, expansion tank and relief valve integrated in the condenser hydraulic module	Easy and fast installation (plug & play), operating safety	61WG 020-190
Set point adjustment by 4-20mA signal	311	Connections to allow a 4-20mA signal input	Easy energy management, allow to adjust set point by a 4-20mA external signal	61WG 020-190
External temperature sensor	312	External temperature sensor control for using weather compensation	Allow to adjust set point using weather compensation and define autorisation operation mode to external temperature	61WG 020-190



## PHYSICAL DATA, 61WG UNITS

61WG			020	025	030	035	040	045	050	060	070	080	090		
<b>Heating</b>															
<b>Standard unit</b> Full load performances*	HW1	Nominal capacity	kW	29	34	38	44	50	57	69	78	88	100	117	
		COP	kW/kW	5,42	5,29	5,21	5,29	5,34	5,32	5,49	5,36	5,46	5,28	5,33	
	HW2	Nominal capacity	kW	28	33	37	43	49	55	66	76	84	95	109	
		COP	kW/kW	4,35	4,34	4,20	4,27	4,32	4,36	4,51	4,32	4,35	4,27	4,31	
	HW3	Nominal capacity	kW	27	32	35	41	47	52	64	74	80	90	103	
		COP	kW/kW	3,65	3,68	3,52	3,59	3,56	3,66	3,75	3,64	3,63	3,56	3,60	
	HW4	Nominal capacity	kW	26	31	34	40	43	49	61	71	76	85	97	
		COP	kW/kW	2,96	2,96	2,86	2,93	2,88	2,96	2,98	3,04	2,99	2,94	2,97	
	HB1	Nominal capacity	kW	22	26	29	34	38	42	50	57	67	75	87	
		COP	kW/kW	4,24	4,26	4,29	4,27	4,27	4,25	4,25	4,27	4,26	4,28	4,29	
	<b>Standard unit</b> Seasonal energy efficiency**	HW1	SCOP <sub>30/35°C</sub>	kW/kW	5,36	5,20	5,11	5,19	5,23	5,19	5,84	5,93	5,93	5,83	5,82
			η <sub>s heat</sub> <sub>30/35°C</sub>	%	206	200	197	200	201	200	226	229	229	225	225
HW3		SCOP <sub>47/55°C</sub>	kW/kW	<b>4,37</b>	<b>4,32</b>	<b>4,20</b>	<b>4,28</b>	<b>4,32</b>	<b>4,35</b>	<b>4,86</b>	<b>4,88</b>	<b>4,80</b>	<b>4,89</b>	<b>4,80</b>	
		η <sub>s heat</sub> <sub>47/55°C</sub>	%	<b>167</b>	<b>165</b>	<b>160</b>	<b>163</b>	<b>165</b>	<b>166</b>	<b>186</b>	<b>187</b>	<b>184</b>	<b>188</b>	<b>184</b>	
		P <sub>rated</sub>	kW	32	38	42	49	56	63	76	88	97	109	124	
		Energy labelling		A++	A++	A++	A++	A++	A++	-	-	-	-	-	
<b>Operating weight<sup>(1)</sup></b>		kg	191	200	200	207	212	220	386	392	403	413	441		
<b>Operating weight with option 258<sup>(1)</sup></b>		kg	198	207	207	214	219	227	399	405	416	426	454		
<b>Sound levels<sup>(2)</sup></b>															
Sound power level, standard unit		dB(A)	67	68	69	69	70	70	72	72	72	73	73		
Sound power level, option 257		dB(A)	65	66	66	67	68	68	68	69	69	69	70		
Sound power level, option 258		dB(A)	61	62	63	63	64	64	66	66	66	67	67		
Sound power level, option 257+258		dB(A)	60	62	62	62	64	63	65	65	65	66	66		
<b>Dimensions, standard unit<sup>(3)</sup></b>															
Width		mm	600	600	600	600	600	600	880	880	880	880	880		
Length		mm	1044	1044	1044	1044	1044	1044	1474	1474	1474	1474	1474		
Height		mm	901	901	901	901	901	901	901	901	901	901	901		
<b>Compressors</b>		Hermetic scroll 48.3 r/s													
Quantity			1	1	1	1	1	1	2	2	2	2	2		
Number of capacity stages			1	1	1	1	1	1	2	2	2	2	2		
Minimum capacity		%	100	100	100	100	100	100	50	50	50	50	50		

\* In accordance with standard EN14511-3:2022

\*\* In accordance with standard EN14825:2022, average climate

HW1 Heating mode conditions: Evaporator entering/leaving water temperature 10°C/7°C, condenser entering/leaving water temperature 30°C/35°C, evaporator and condenser fouling factor 0 m<sup>2</sup>. k/W

HW2 Heating mode conditions: Evaporator entering/leaving water temperature 10°C/7°C, condenser entering/leaving water temperature 40°C/45°C, evaporator and condenser fouling factor 0 m<sup>2</sup>. k/W

HW3 Heating mode conditions: Evaporator entering/leaving water temperature 10°C/7°C, condenser entering/leaving water temperature 47°C/55°C, evaporator and condenser fouling factor 0 m<sup>2</sup>. k/W

HW4 Heating mode conditions: Evaporator entering/leaving water temperature 10°C/7°C, condenser entering/leaving water temperature 55°C/65°C, evaporator and condenser fouling factor 0 m<sup>2</sup>. k/W

HB1 Heating mode conditions: Evaporator entering/leaving water temperature 0°C/-3°C, condenser entering/leaving water temperature 30°C/35°C, evaporator and condenser fouling factor 0 m<sup>2</sup>.K/W, evaporator fluid: 30% ethylene glycol.

η<sub>s heat</sub><sub>30/35°C</sub>& SCOP<sub>30/35°C</sub> Values calculated in accordance with EN14825:2022

η<sub>s heat</sub><sub>47/55°C</sub>& SCOP<sub>47/55°C</sub> **Bold values compliant to Ecodesign regulation: (EU) No 813/2013 for Heat Pump application**

- Not applicable

(1) Weight shown is a guideline only. Please refer to the unit nameplate

(2) In dB ref=10<sup>-12</sup> W, (A) weighting. Declared dualnumber noise emission values in accordance with ISO 4871 (with an associated uncertainty of +/-3dB(A)). Measured in accordance with ISO 9614-1.

(3) The dimensions shown are for the standard unit. For other unit types please refer to the dimensional drawings



Eurovent certified values

## PHYSICAL DATA, 61WG UNITS

61WG		020	025	030	035	040	045	050	060	070	080	090
<b>Refrigerant<sup>(1)</sup></b>		R410A (GWP=2088 Following ARI4)										
Charge, standard unit	kg	3,5	3,5	3,6	3,7	4,0	4,6	7,6	7,8	7,9	8,7	11,5
	teqCO <sub>2</sub>	7,2	7,3	7,4	7,6	8,2	9,5	15,9	16,3	16,5	18,2	24
Charge, unit with option 272	kg	2,7	2,9	2,9	3,0	3,2	3,9	7,2	7,3	7,4	7,6	10,5
	teqCO <sub>2</sub>	5,6	6,0	6,1	6,3	6,7	8,1	14,9	15,2	15,5	15,9	21,9
<b>Capacity control</b>		SmartVu™										
<b>Evaporator</b>		Direct-expansion plate heat exchanger										
Water volume	l	3,3	3,6	3,6	4,2	4,6	5,0	8,4	9,2	9,6	10,4	12,5
Water connections		Raccordements Victaulic										
Inlet/outlet	in	1,5	1,5	1,5	1,5	1,5	1,5	2	2	2	2	2
Max. water-side operating pressure without hydraulic module	kPa	1000	1000	1000	1000	1000	1000	1000	1000	1000	1000	1000
<b>Condenser</b>		Plate heat exchanger										
Net water volume	l	3,3	3,6	3,6	4,2	4,6	5,0	8,4	9,2	9,6	10,4	12,5
Water connections		Victaulic										
Inlet/outlet	in	1,5	1,5	1,5	1,5	1,5	1,5	2	2	2	2	2
Max. water-side operating pressure without hydraulic module	kPa	1000	1000	1000	1000	1000	1000	1000	1000	1000	1000	1000
<b>Chassis paint color</b>		Color code: RAL7035										

(1) Weight shown is a guideline only. Please refer to the unit nameplate

## PHYSICAL DATA, 61WG UNITS

61WG			110	120	140	150	170	190	
<b>Heating</b>									
<b>Standard unit</b> Full load performances*	HW1	Nominal capacity	kW	135	151	175	183	204	235
		COP	kW/kW	5,48	5,44	5,44	5,62	5,49	5,48
	HW2	Nominal capacity	kW	131	147	168	176	197	226
		COP	kW/kW	4,56	4,53	4,55	4,63	4,52	4,53
	HW3	Nominal capacity	kW	124,4	140,7	161,3	166,0	186,2	212,5
		COP	kW/kW	3,58	3,48	3,56	3,53	3,42	3,49
	HW4	Nominal capacity	kW	118	131	150	157	174	200
		COP	kW/kW	2,83	2,74	2,85	2,86	2,70	2,85
	HB1	Nominal capacity	kW	102	114	133	135	153	177
		COP	kW/kW	4,42	4,39	4,42	4,40	4,39	4,38
<b>Standard unit</b> Seasonal energy efficiency**	HW1	SCOP <sub>30/35°C</sub>	kW/kW	6,20	6,32	6,24	6,18	6,19	6,03
		η <sub>s heat</sub> <sub>30/35°C</sub>	%	241	245	242	240	240	234
	HW3	<b>SCOP<sub>47/55°C</sub></b>	<b>kW/kW</b>	<b>5,03</b>	<b>5,03</b>	<b>5,03</b>	<b>5,02</b>	<b>5,05</b>	<b>4,93</b>
		<b>η<sub>s heat</sub><sub>47/55°C</sub></b>	<b>%</b>	<b>194</b>	<b>193</b>	<b>193</b>	<b>194</b>	<b>194</b>	<b>190</b>
		P <sub>rated</sub>	kW	144	162	185	193	215	247
<b>Operating weight</b> (1)			kg	707	733	758	841	877	908
<b>Sound levels</b> (2)									
Sound power level, standard unit			dB(A)	76	77	78	76	77	78
Sound power level, option 257			dB(A)	73	74	75	73	74	75
<b>Dimensions, standard unit</b> (3)									
Width			mm	880	880	880	880	880	880
Length			mm	1583	1583	1583	1583	1583	1583
Height			mm	1574	1574	1574	1574	1574	1574
<b>Compressors</b>			Hermetic scroll 48.3 r/s						
Quantity				3	3	3	4	4	4
Number of capacity stages				3	3	3	4	4	4
Minimum capacity			%	33	33	33	25	25	25
<b>Refrigerant</b> (1)			R410A (GWP=2088 Following ARI4)						
Charge, standard unit			kg	13,3	14,5	15,6	21,0	23,0	24,2
			teqCO <sub>2</sub>	27,8	30,3	32,6	43,8	48,0	50,5
<b>Capacity control</b>			SmartVu™						

- \* In accordance with standard EN14511-3:2022  
 \*\* In accordance with standard EN14825:2022, average climate
- HW1 Heating mode conditions: Evaporator entering/leaving water temperature 10°C/7°C, condenser entering/leaving water temperature 30°C/35°C, evaporator and condenser fouling factor 0 m<sup>2</sup>. kW/W
- HW2 Heating mode conditions: Evaporator entering/leaving water temperature 10°C/7°C, condenser entering/leaving water temperature 40°C/45°C, evaporator and condenser fouling factor 0 m<sup>2</sup>. kW/W
- HW3 Heating mode conditions: Evaporator entering/leaving water temperature 10°C/7°C, condenser entering/leaving water temperature 47°C/55°C, evaporator and condenser fouling factor 0 m<sup>2</sup>. kW/W
- HW4 Heating mode conditions: Evaporator entering/leaving water temperature 10°C/7°C, condenser entering/leaving water temperature 55°C/65°C, evaporator and condenser fouling factor 0 m<sup>2</sup>. kW/W
- HB1 Heating mode conditions: Evaporator entering/leaving water temperature 0°C/-3°C, condenser entering/leaving water temperature 30°C/35°C, evaporator and condenser fouling factor 0 m<sup>2</sup>.kW/W, evaporator fluid: 30% ethylene glycol.
- η<sub>s heat</sub><sub>30/35°C</sub> & SCOP<sub>30/35°C</sub>  
 η<sub>s heat</sub><sub>47/55°C</sub> & SCOP<sub>47/55°C</sub>  
 (1) Values calculated in accordance with EN14825:2022  
**Bold values compliant to Ecodesign regulation: (EU) No 813/2013 for Heat Pump application**  
 (2) Weight shown is a guideline only. Please refer to the unit nameplate  
 In dB ref=10<sup>-12</sup> W, (A) weighting. Declared dualnumber noise emission values in accordance with ISO 4871 (with an associated uncertainty of +/-3dB(A)). Measured in accordance with ISO 9614-1.  
 (3) The dimensions shown are for the standard unit. For other unit types please refer to the dimensional drawings



Eurovent certified values

## PHYSICAL DATA, 61WG UNITS

61WG		110	120	140	150	170	190
<b>Evaporator</b>		Direct-expansion plate heat exchanger					
Water volume	l	15,18	17,35	19,04	23,16	26,52	29,05
Water connections		Victaulic					
Inlet/outlet	in	2 1/2	2 1/2	2 1/2	3	3	3
Max. water-side operating pressure without hydraulic module	kPa	1000	1000	1000	1000	1000	1000
<b>Condenser</b>		Plate heat exchanger					
Net water volume	l	15,18	17,35	19,04	23,16	26,52	29,05
Water connections		Victaulic					
Inlet/outlet	in	2 1/2	2 1/2	2 1/2	3	3	3
Max. water-side operating pressure without hydraulic module	kPa	1000	1000	1000	1000	1000	1000
<b>Chassis paint color</b>		Color code: RAL7035					

## ELECTRICAL DATA

61WG without hydraulic module		020	025	030	035	040	045	050	060	070	080	090
<b>Power circuit</b>												
Nominal voltage	V-ph-Hz	400-3-50										
Voltage range	V	360-440										
<b>Control circuit supply</b>												
24 V, via internal transformer												
<b>Maximum start-up current draw (Un)<sup>(1)</sup></b>												
Standard unit	A	98	142	142	147	158	197	161,6	163	171,4	184,7	227,9
Unit with electronic starter option	A	53,9	78,1	78,1	80,9	86,9	108,4	97,7	99,2	105,2	113,6	139,2
<b>Unit power factor at maximum capacity<sup>(2)</sup></b>												
		0,9	0,8	0,9	0,9	0,9	0,9	0,8	0,9	0,9	0,9	0,9
<b>Maximum operating power input<sup>(2)</sup></b>												
	kW	9,5	11,3	12,4	14,4	15,9	18,2	22,5	24,9	28,7	31,8	36,4
<b>Nominal unit operating current draw<sup>(3)</sup></b>												
	A	10,6	12,9	13,3	15,2	16,5	19,7	25,8	26,6	30,4	33,0	39,4
<b>Maximum operating current draw (Un)<sup>(4)</sup></b>												
	A	16,1	19,6	21,1	24,4	26,7	30,9	39,2	42,2	48,8	53,4	61,8
<b>Maximum operating current draw (Un-10%)*</b>												
	A	17,9	21,8	23,4	27,1	29,7	34,3	43,6	46,9	54,2	59,3	68,7
<b>Customer-side unit power reserve</b>												
Customer reserve at the 24 V control power circuit												
<b>Short-circuit stability and protection</b>												
See table below "Short-circuit stability current"												

61WG without hydraulic module		110	120	140	150	170	190
<b>Power circuit</b>							
Nominal voltage	V-ph-Hz	400-3-50					
Voltage range	V	360-440					
<b>Control circuit supply</b>							
24 V, via internal transformer							
<b>Maximum start-up current draw (Un)<sup>(1)</sup></b>							
Standard unit	A	195,8	211,4	258,8	220,2	238,1	289,7
Unit with electronic starter option	A	129,7	140,3	170,2	154,1	167	201,1
<b>Unit power factor at maximum capacity<sup>(2)</sup></b>							
		0,87	0,85	0,85	0,87	0,85	0,85
<b>Maximum operating power input<sup>(2)</sup></b>							
	kW	44	47	55	59	63	73
<b>Nominal unit operating current draw<sup>(3)</sup></b>							
	A	45,6	49,5	59,1	60,8	66	78,8
<b>Maximum operating current draw (Un)<sup>(4)</sup></b>							
	A	73,2	80,1	92,7	97,6	106,8	123,6
<b>Maximum operating current draw (Un-10%)*</b>							
	A	81,3	89	103	108,4	118,7	137,3
<b>Customer-side unit power reserve</b>							
Customer reserve at the 24 V control power circuit							
<b>Short-circuit stability and protection</b>							
See table below "Short-circuit stability current"							

- (1) Maximum instantaneous start-up current at operating limit values (maximum operating current of the smallest compressor(s) + locked rotor current or limited start-up current of the largest compressor).
- (2) Maximum power input at the unit operating limits.
- (3) Values obtained at standardised Eurovent conditions: evaporator entering/leaving water temperature 10 °C/7 °C, condenser entering/leaving water temperature 30 °C/35 °C.
- (4) Maximum unit operating current at maximum unit power input and 400 V.
- \* Maximum unit operating current at maximum unit power input and 360 V.



## ELECTRICAL DATA

### Short-circuit stability current (TN system<sup>(1)</sup>) - standard unit (with main disconnect switch)

61WG		020	025	030	035	040	045	050	060	070	080	090
<b>Value with non-specified upstream protection</b>												
Short-term current at 1 s - I <sub>cw</sub>	kA rms	3	3	3	3	3	3	3	3	3	3	3
Admissible peak current - I <sub>pk</sub>	kA pk	6	6	6	6	6	6	6	6	6	6	6
<b>Maximum value with upstream protection (by circuit breaker)</b>												
Conditional short-circuit current I <sub>cc</sub>	kA rms	40	40	40	40	40	40	40	40	40	40	40
Schneider circuit breaker - Compact series		NSX 100N										
Reference number <sup>(2)</sup>		LV429795										

(1) Earthing system type

(2) If another current limitation protection system is used, its time-current and thermal constraint (I<sup>2</sup>t) trip characteristics must be at least equivalent to those of the recommended Schneider circuit breaker.

The short-circuit stability current values above are suitable with the TN system.

61WG		110	120	140	150	170	190
<b>Value with non-specified upstream protection</b>							
Short-term current at 1 s - I <sub>cw</sub>	kA rms	5,5	5,5	5,5	5,5	5,5	5,5
Admissible peak current - I <sub>pk</sub>	kA pk	20	20	20	20	20	20
<b>Maximum value with upstream protection (by circuit breaker)</b>							
Conditional short-circuit current I <sub>cc</sub>	kA rms	154	154	154	154	154	154
Schneider circuit breaker - Compact series		NSX 100N					
Reference number <sup>(2)</sup>		LV429795					

(1) Earthing system type

(2) If another current limitation protection system is used, its time-current and thermal constraint (I<sup>2</sup>t) trip characteristics must be at least equivalent to those of the recommended Schneider circuit breaker.

The short-circuit stability current values above are suitable with the TN system.

## DIMENSIONS/CLEARANCES

### 61WG 020-045 - standard unit

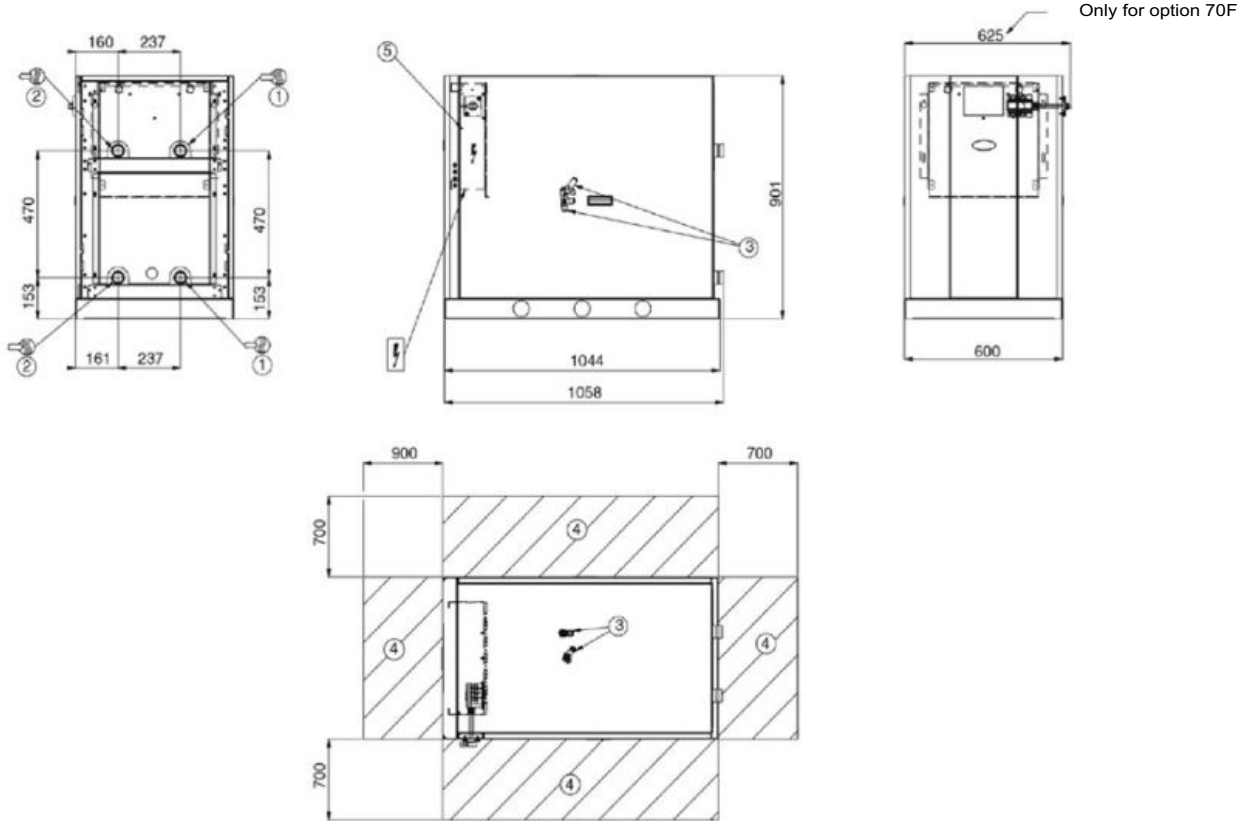

### 61WG 020-045 - unit with top connections (option 274)

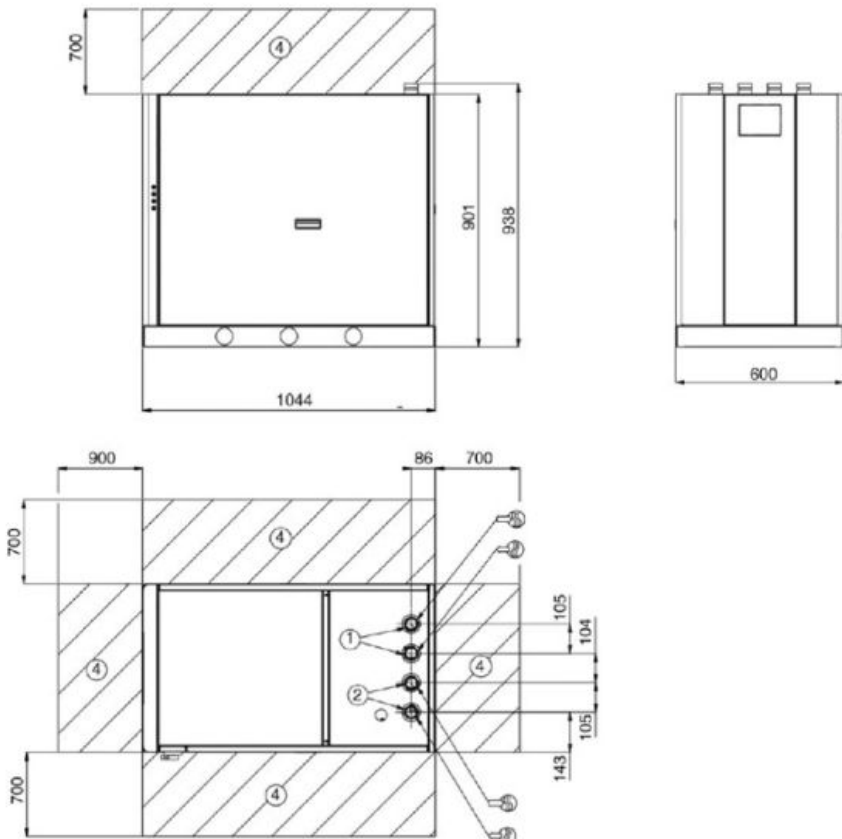

**Legend**

All dimensions are in mm.

- ① Evaporator
- ② Condenser
- ③ Safety valve
- ④ Clearances required for maintenance (see note)
- ⑤ Control box
- Water inlet.
- Water outlet
- Power wiring connection

**NOTE:** Non-contractual drawings. Refer to the certified dimensional drawings available on request, when designing an installation.

## DIMENSIONS/CLEARANCES

### 61WG 020-045 - unit with evaporator hydraulic module (option 116)

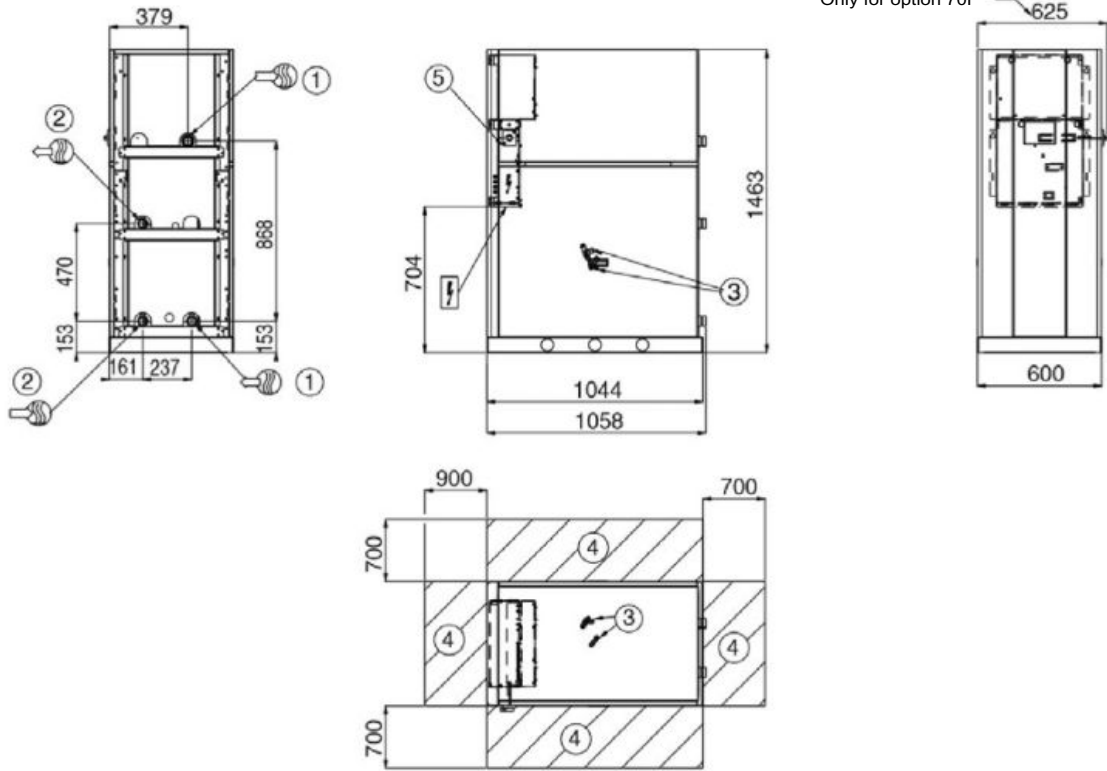

### 61WG 020-045 - unit with condenser hydraulic module (option 270)

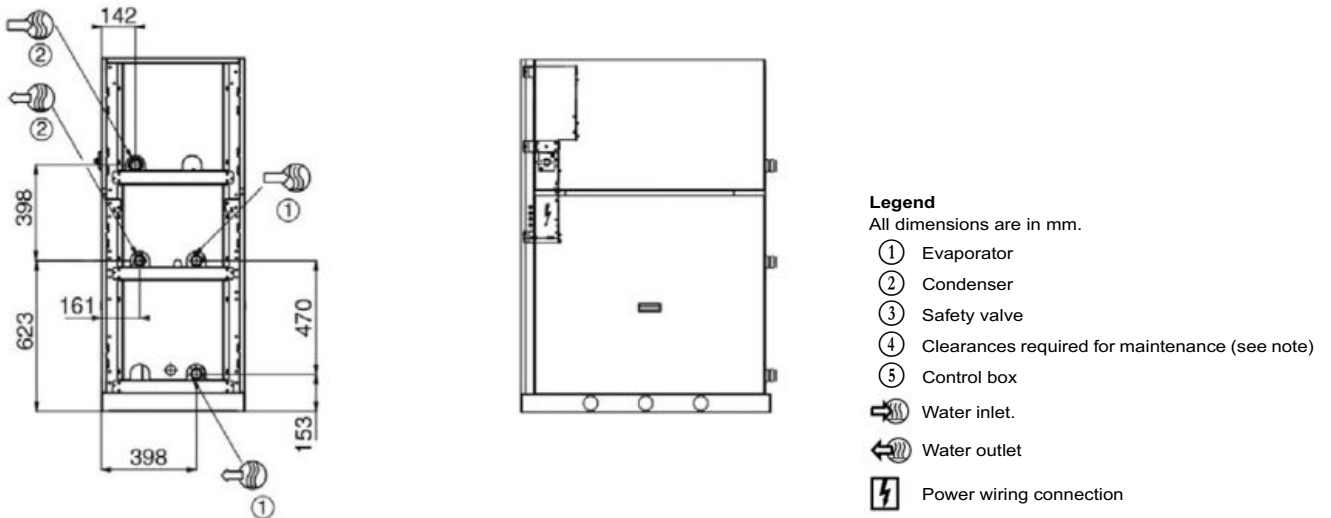

**NOTE:** Non-contractual drawings. Refer to the certified dimensional drawings available on request, when designing an installation.

## DIMENSIONS/CLEARANCES

### 61WG 020-045 - unit with evaporator/condenser hydraulic modules (options 116 + 270)

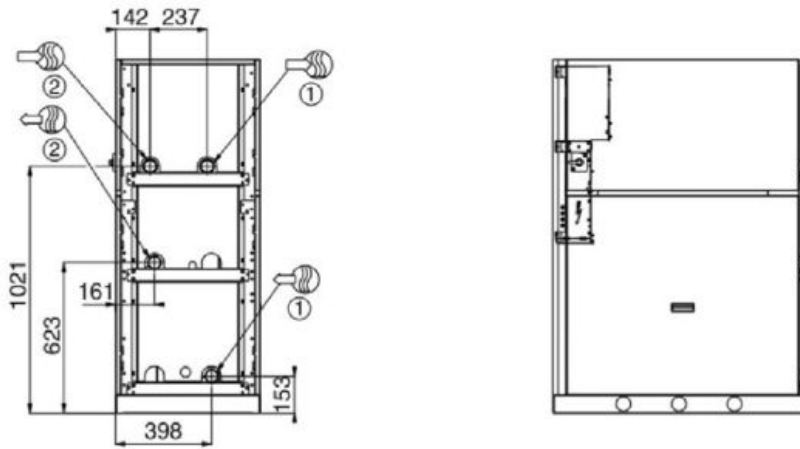

### 61WG 020-045 - unit with hydraulic module and top connections (options 116 + 274 or 270 + 274 or 116 + 270 + 274)

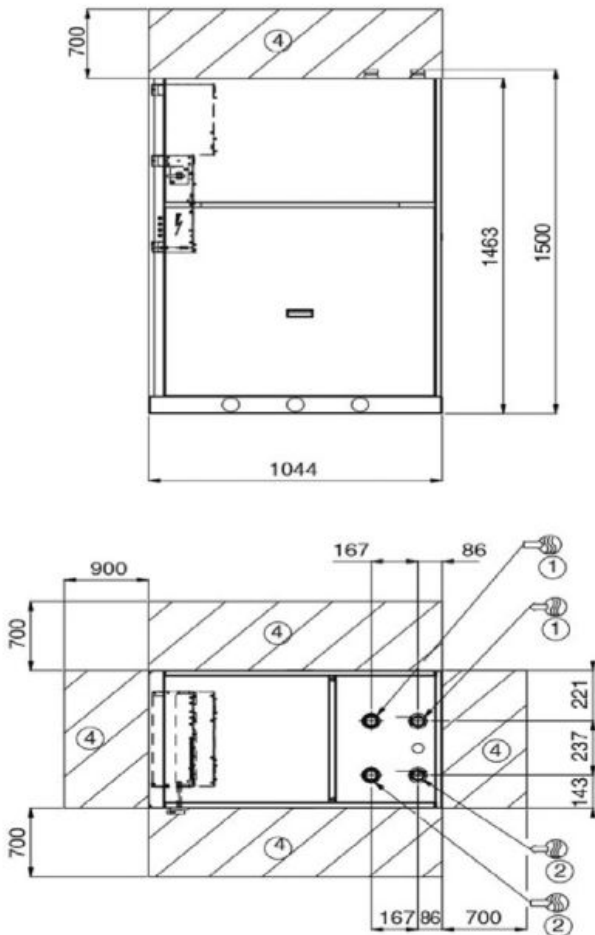

#### Legend

All dimensions are in mm.

- ① Evaporator
- ② Condenser
- ③ Safety valve
- ④ Clearances required for maintenance (see note)
- ⑤ Control box
- Water inlet.
- Water outlet
- Power wiring connection

**NOTE:** Non-contractual drawings. Refer to the certified dimensional drawings available on request, when designing an installation.

## DIMENSIONS/CLEARANCES

### 61WG 020-045 - stackable unit (option 273)

**NOTE:** The water and electrical connections are identical to those of the standard unit.

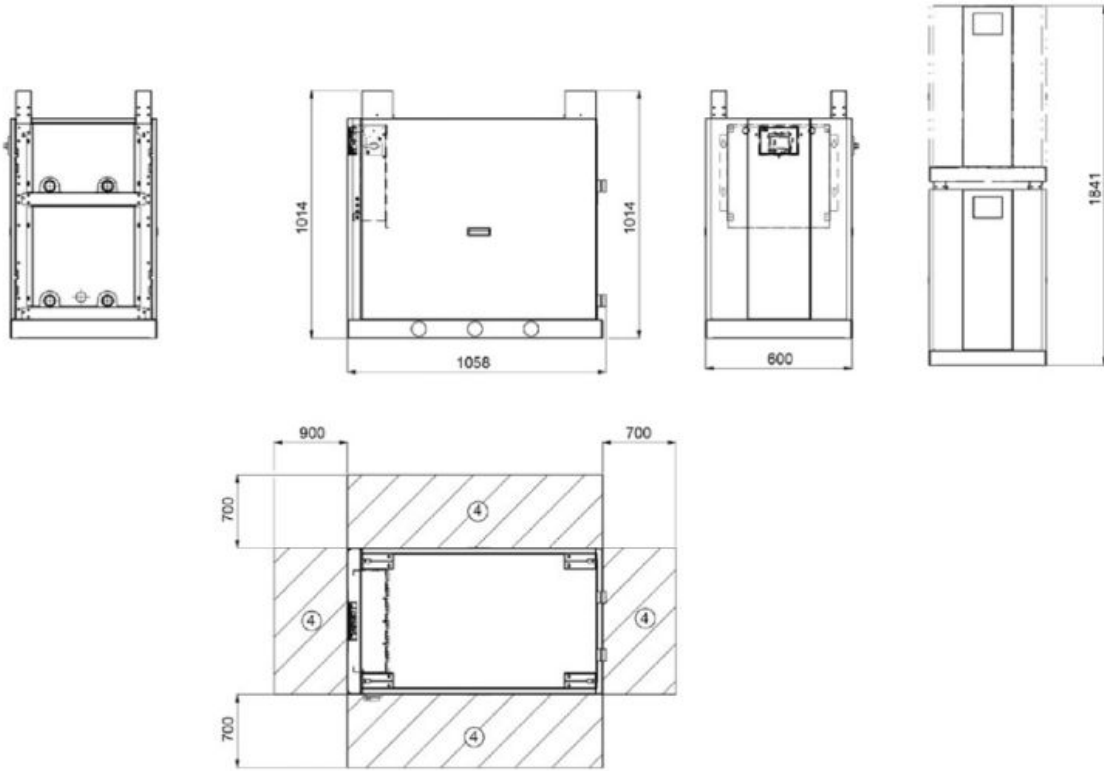

### 61WG 050-090 - standard unit

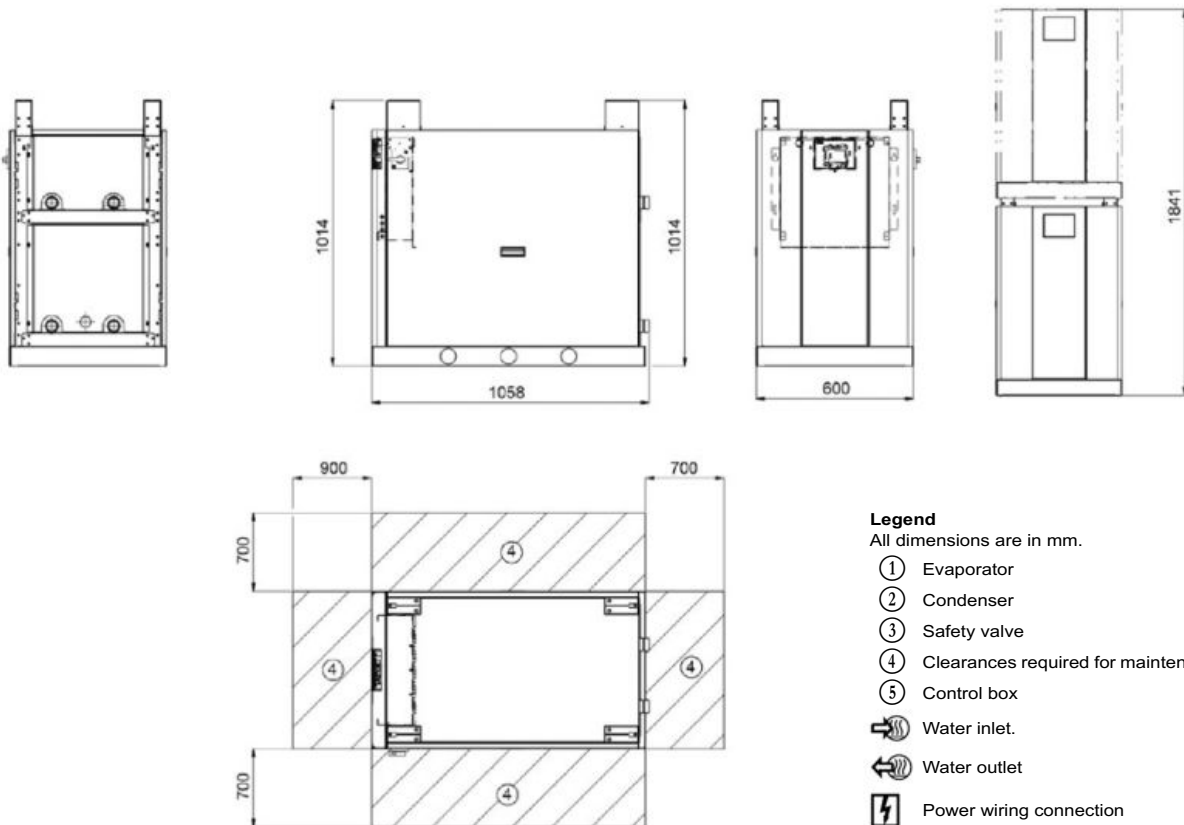

**Legend**

All dimensions are in mm.

- ① Evaporator
- ② Condenser
- ③ Safety valve
- ④ Clearances required for maintenance (see note)
- ⑤ Control box
- Water inlet.
- Water outlet
- Power wiring connection

**NOTE:** Non-contractual drawings. Refer to the certified dimensional drawings available on request, when designing an installation.



## DIMENSIONS/CLEARANCES

### 61WG 050-090 - unit with top connections (option 274)

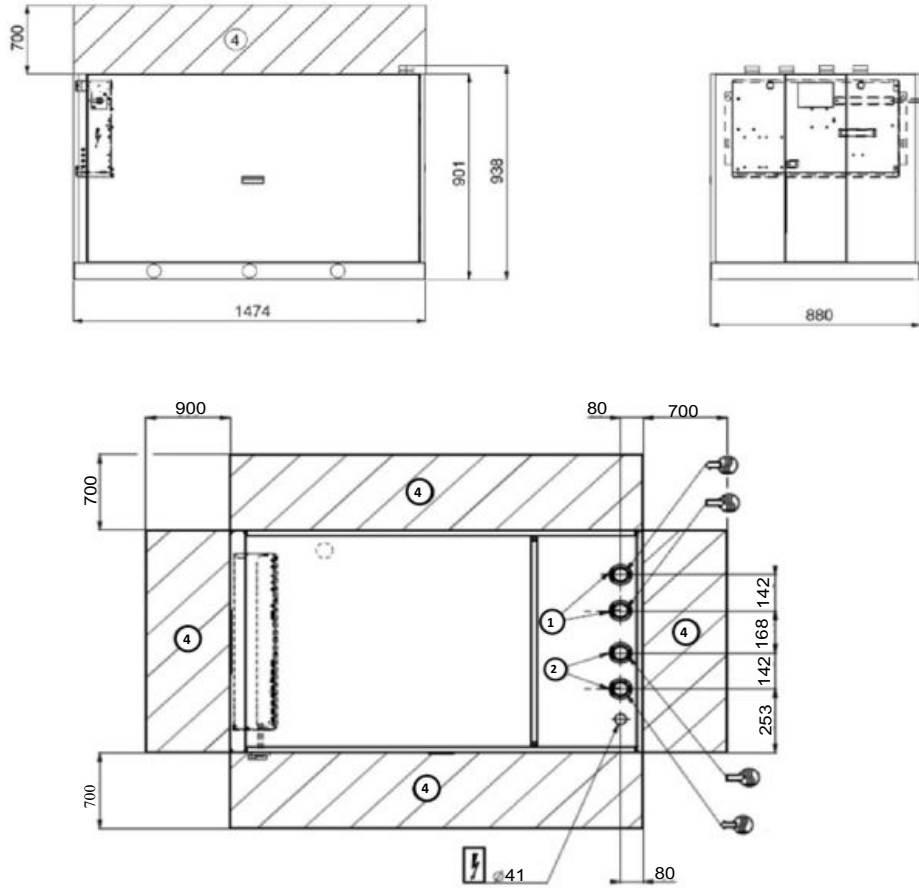

### 61WG 050-090 - unit with evaporator hydraulic module (option 116)

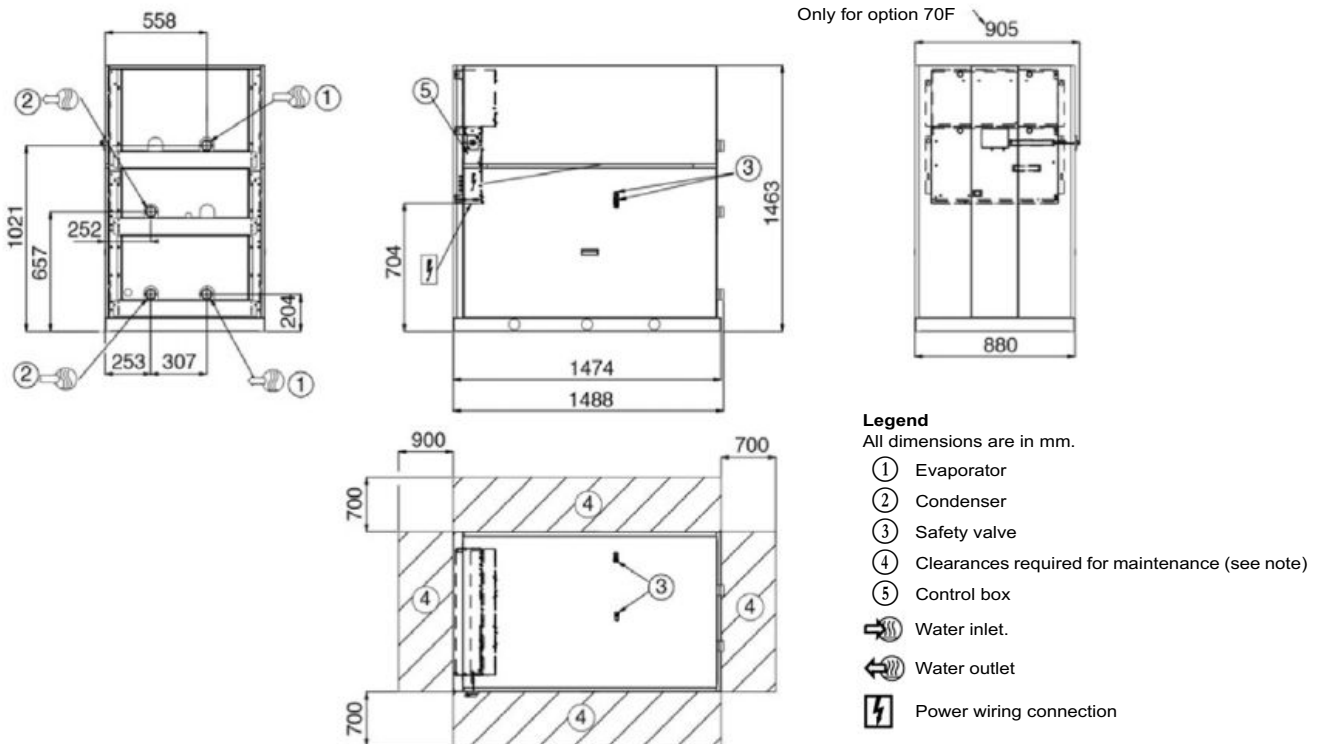

**NOTE:** Non-contractual drawings. Refer to the certified dimensional drawings available on request, when designing an installation.

## DIMENSIONS/CLEARANCES

### 61WG 050-090 - unit with condenser hydraulic module (option 270)

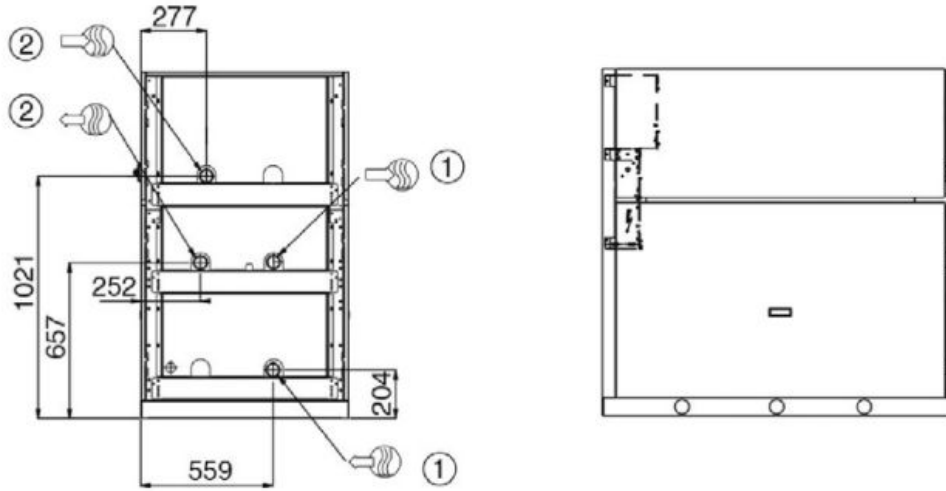

### 61WG 050-090 - unit with evaporator/condenser hydraulic modules (options 116 + 270)

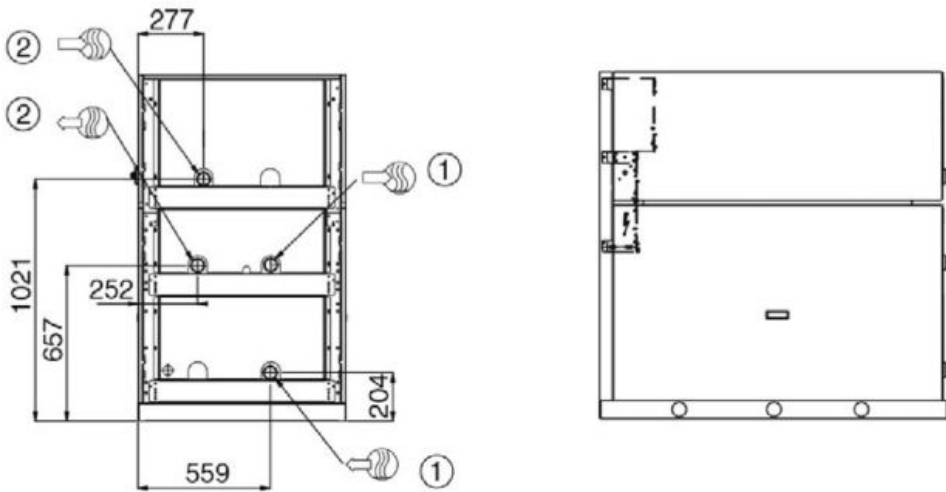

**Legend**

All dimensions are in mm.

- ① Evaporator
- ② Condenser
- ③ Safety valve
- ④ Clearances required for maintenance (see note)
- ⑤ Control box
- Water inlet.
- Water outlet
- Power wiring connection

**NOTE:** Non-contractual drawings. Refer to the certified dimensional drawings available on request, when designing an installation.

## DIMENSIONS/CLEARANCES

**61WG 050-090 - unit with hydraulic module and top connections (options 116 + 274 or 270 + 274 or 116 + 270 + 274)**

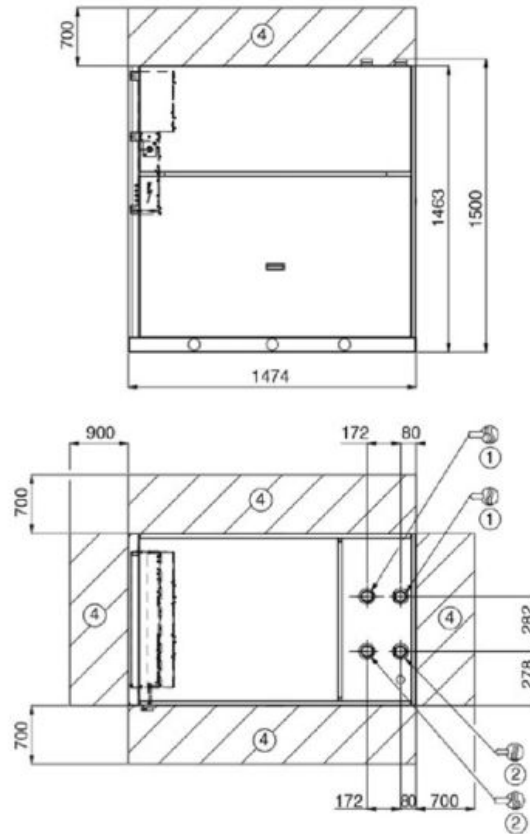

**61WG 050-090 - stackable unit (option 273)**

**NOTE:** The water and electrical connections are identical to those of the standard unit.

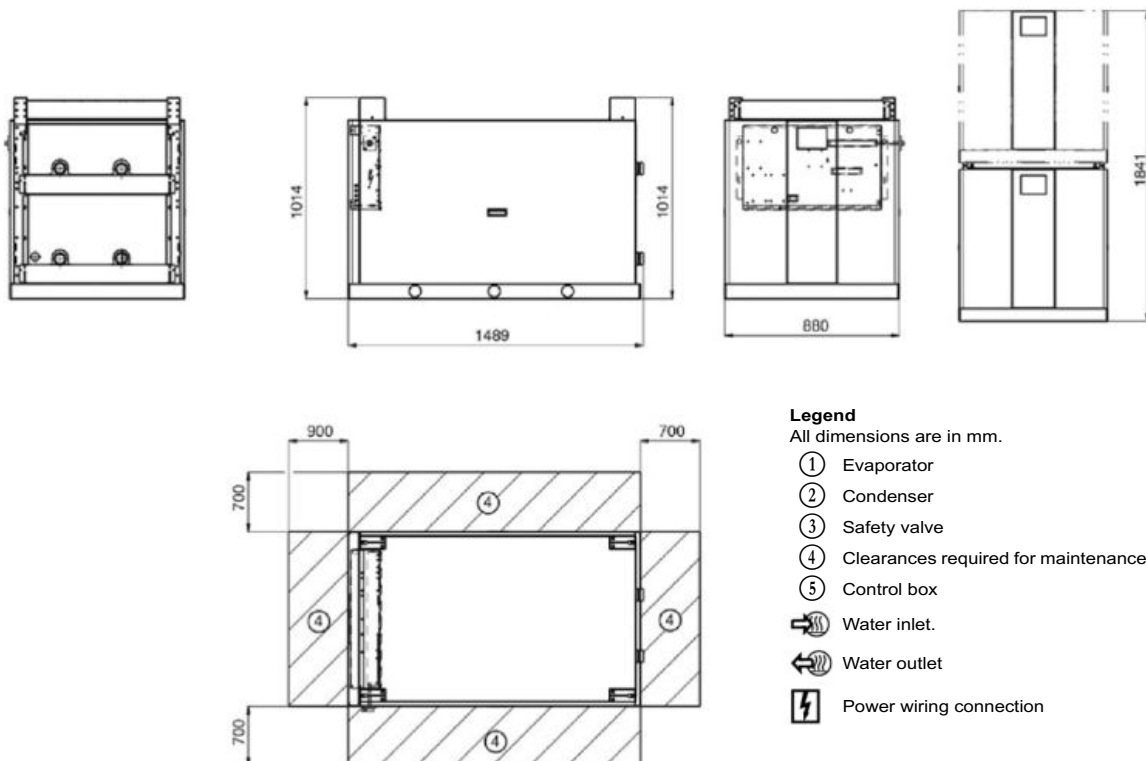

**Legend**

All dimensions are in mm.

- ① Evaporator
- ② Condenser
- ③ Safety valve
- ④ Clearances required for maintenance (see note)
- ⑤ Control box
- ➔ Water inlet.
- ➔ Water outlet
- ⚡ Power wiring connection

**NOTE:** Non-contractual drawings. Refer to the certified dimensional drawings available on request, when designing an installation.



## WATER-COOLED AND CONDENSERLESS LIQUID CHILLERS WATER-SOURCED HEAT PUMPS



30WG optimized for cooling  
Compact design  
Plug and play approach  
High efficiency

## 30WG



Nominal heating capacity 29-230 kW  
Nominal cooling capacity 25-190 kW

The 30WG/30WGA units are new Carrier chillers and heat pumps designed for commercial (offices, small hotels, leisure facilities), residential and industrial applications. All units offer a unique combination of high performance and functionality in an exceptionally compact chassis.

The 30WG, also available as a condenserless version (30WGA), is designed for air-conditioning applications with a high SEER value. As they can produce chilled water down to -12 °C they are also suitable for process applications.

A large number of options is available for the whole range:

- hydraulic modules with or without variable water flow rate,
- reinforced sound insulation,
- stacking and connection of two units
- low-temperature applications down to -12 °C (30WG only).



CARRIER participates in the ECP programme for LCP-HP  
Check ongoing validity of certificate:  
[www.eurovent-certification.com](http://www.eurovent-certification.com)



## CUSTOMER BENEFITS

### Features

- Reduced footprint
- Scroll compressors and R-410A refrigerant
- Variable-flow pump
- Low-noise option (-3 dB(A))
- Stacking of two units for increased capacity (up to size 090)
- Several communication protocols available: JBus, BacNet, MS/TP, LON
- Water connection at the top or rear (30WG only)

### Available versions

#### 30WG - optimised for air conditioning and process Heating & Cooling

- Evaporator temperature down to -12 °C
- Condenser temperature up to +60 °C
- Condensing pressure control devices available

#### 30WGA - optimised for air conditioning

- Continuous operation up to 62 °C saturated condensing temperature
- Compatible remote condensers available
- Optimised remote condenser fan control

### The right unit for any application

- Option 153 "Built-in DHW and space heating control" allows control of both domestic hot water and space heating requirements:
  - Domestic hot water production: a built-in three-way valve is directed to divert the heat flow from the space heating loop to the domestic hot water loop and vice versa.
  - Space heating control: the setpoint is adjustable, based on the daily schedule or the outside air temperature (weather compensation function).
  - Control of auxiliary systems: if an alarm is detected at the 30WG or if there is insufficient heating capacity, a digital signal starts an auxiliary electric heater (1 to 4 stages) or boiler.
  - Pump control: allows control of the built-in pump as well as the pump in the secondary loop (to terminals).
- In 30WG units the pressure control signal ensures safe unit operation and maximised performance at low source-side water temperatures.

- The condenserless 30WGA units are ideal for refurbishment projects where a remote condenser exists on site, and for all projects without geothermal/natural sinks for heat rejection.
- In 30WG units the Heating System Manager (HSM) accessory allows control of systems with several heat sources and different additional systems: electric heat, boiler or for the most complex systems district heating (see pages 9 to 11).

### Adaptability and simple installation

- The 30WG units can be provided with several hydraulic module options, both on the evaporator and/or condenser side, with different levels of available pressure and variable or fixed-speed pumps (see page 7).
- If option 153 is selected domestic hot water production is controlled via a built-in three-way diverter valve (not supplied).
- 30WG units offer water-side cooling/heating reversibility.
- Remote condenser fan control possible for 30WGA units.

### Water connections at the rear of the unit



## CUSTOMER BENEFITS

**Internal view of 30WG 170**



**Component accessibility**

See photos below.

**Access to scroll compressors**



**Water connections at the top of the unit**



**Access to control panel**



### A compact high-performance product range

- Small footprint, ideal for refurbished buildings, allows access in very tight plant rooms.
- 30WG: High SEER and SEPR
- Units optimized for process and comfort applications.
- The 30WGA is based on the 30WG design to ensure efficient operation for applications with remote air-cooled condensers.
- Variable-flow pumps reduce system energy consumption.
- The entire range offers low sound levels, allowing installation in any building type. The low-noise option ensures enhanced acoustic comfort (-3 dB(A)).
- 30WG/30WGA units are equipped with the latest generation R410A scroll compressor, optimised for typical operating conditions for water-sourced units.

### Two-unit stacking option for reduced footprint size 020-090

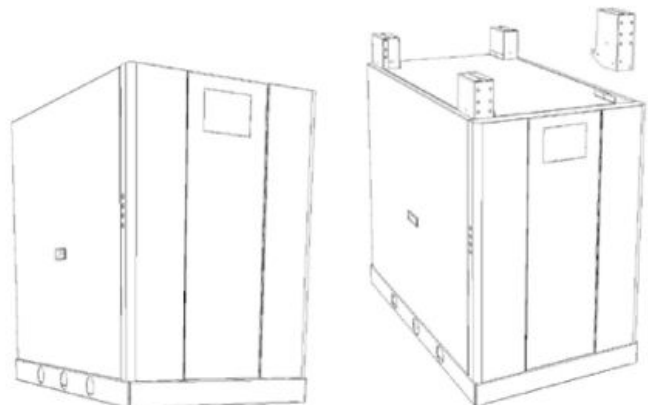

## CUSTOMER BENEFITS

### SmartVu™ control

The SmartVu™ control combines intelligence with operating simplicity. The control constantly monitors all machine parameters and precisely manages the operation of compressors, expansion devices, fans and the evaporator water pump for optimum energy efficiency.

The SmartVu™ control features advanced communication technology over Ethernet (IP) and a user-friendly and intuitive user interface with 4.3-inch colour touch screen.

- Energy management configuration
  - Internal timer: controls chiller on/off times and operation at a second setpoint
  - Setpoint offset based on the outdoor air temperature
  - Master/slave control of two chillers operating in parallel with runtime balancing and automatic changeover in case of a unit fault.
  - Innovative smart energy monitoring, providing users with smart data such as real-time electrical energy consumption and cooling capacity, and instantaneous and average energy efficiency values.
  - For further energy savings, the AquaSnap® can be monitored remotely by Carrier experts for energy consumption diagnosis and optimisation.
- Integrated features
  - Night mode: Capacity and fan speed limitation for reduced noise level
  - With hydraulic module: Water pressure display and water flow rate calculation.
- Advanced communication features
  - Easy and high-speed communication technology over Ethernet (IP) to a centralised building management system
  - Access to multiple unit parameters.
- Maintenance functions
  - F-Gas regulation leak check reminder alert
  - Maintenance alert can be configured to days, months or hours of operation
  - Display of trend curves for the main values
  - Management of a fault memory allowing a log of the last 50 incidents to be accessed, with operating readings taken when the fault occurs
  - Blackbox memory

- 4"3 SmartVu™ user interface

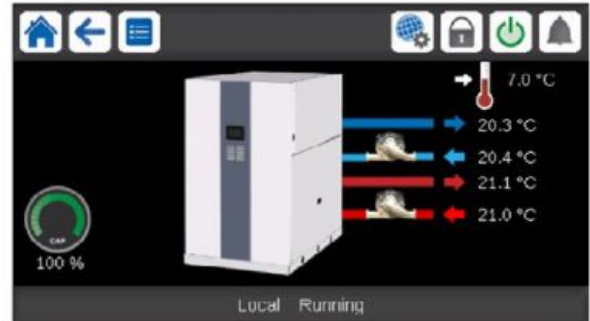

- Intuitive and user-friendly 4"3 inch touch screen interface
- Concise and clear information is available in local languages
- Complete menu, customised for different users (end user, service personnel or Carrier engineers).

### Remote management (standard)

Units with SmartVu™ control can be easily accessed from the internet, using a PC with an Ethernet connection. This makes remote control quick and easy and offers significant advantages for service operations.

The AquaSnap® is equipped with an RS485 serial port that offers multiple remote control, monitoring and diagnostic possibilities. Carrier offers a vast choice of control products, specially designed to control, manage and supervise the operation of an air conditioning system. Please consult your Carrier representative for more information.

The AquaSnap® also communicates with other centralised building management systems via optional communication gateways.

A connection terminal allows the AquaSnap® unit to be remotely controlled by wire:

- Start/stop: Opening of this contact will shut down the unit
- Dual setpoint: closing of this contact activates a second setpoint (e.g.: unoccupied mode).
- Demand limit: Closing of this contact limits the maximum chiller capacity to a predefined value.
- Operation indication: This volt-free contact indicates that the chiller is operating (cooling load).
- Alarm indication: this volt-free contact indicates the presence of a major fault that has led to the shut-down of one or several refrigerant circuits.

## CUSTOMER BENEFITS

### 30WG/30WGA units compatible the Carrier 09 series dry coolers/remote condensers

The Carrier 09 series dry coolers and remote condensers are compatible with the 30WG and 30WGA units.

The chiller 30WG/30WGA can control the fans of the dry cooler / remote condenser via digital or analogue outputs (according to AC or EC motors) with following options :

- For chiller 30WG/30WGA : option 154
- For dry cooler / remote condenser : dedicated control cabinet with an auxiliary board.

A simple communication bus is required between the chiller and the dry cooler/ remote condenser.

As all control components are installed and tested in the factory, installation and start-up of the unit and its associated dry cooler/remote condenser are simplified.

Control board algorithms optimise energy consumption based on:

- the outside temperature and chilled-water temperature read for dry coolers
- the outside temperature and saturated refrigerant discharge temperature read for remote condensers.

A simple communication bus is required downstream to connect the control board to the unit control.

### 30WG system concept

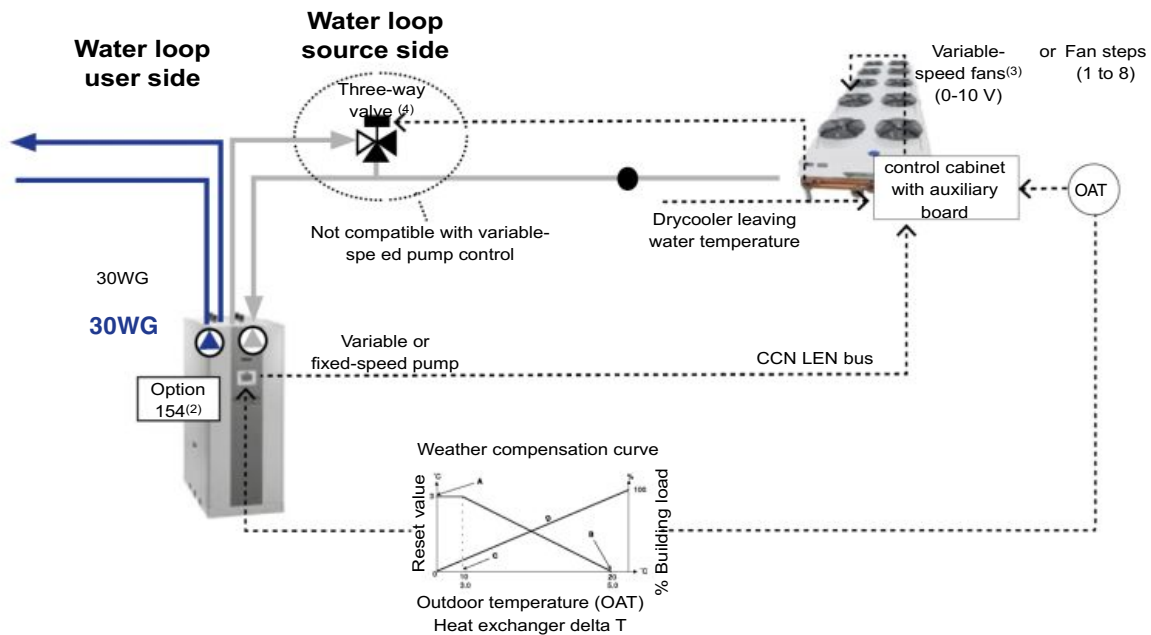

#### Legend

- CCN** Carrier Comfort Network
- LEN** Local equipment network
- OAT** Outside air temperature
- (1) Control board option on 09PE dedicated to 30WG
- (2) Option 154 for connection and communication with 09PE Drycooler
- (3) For correct operation of the unit below 0 °C variable speed fans are required.
- (4) Three-Way valve or two two-way valves optional on 09PE

**CUSTOMER BENEFITS**

**30WGA system concept**

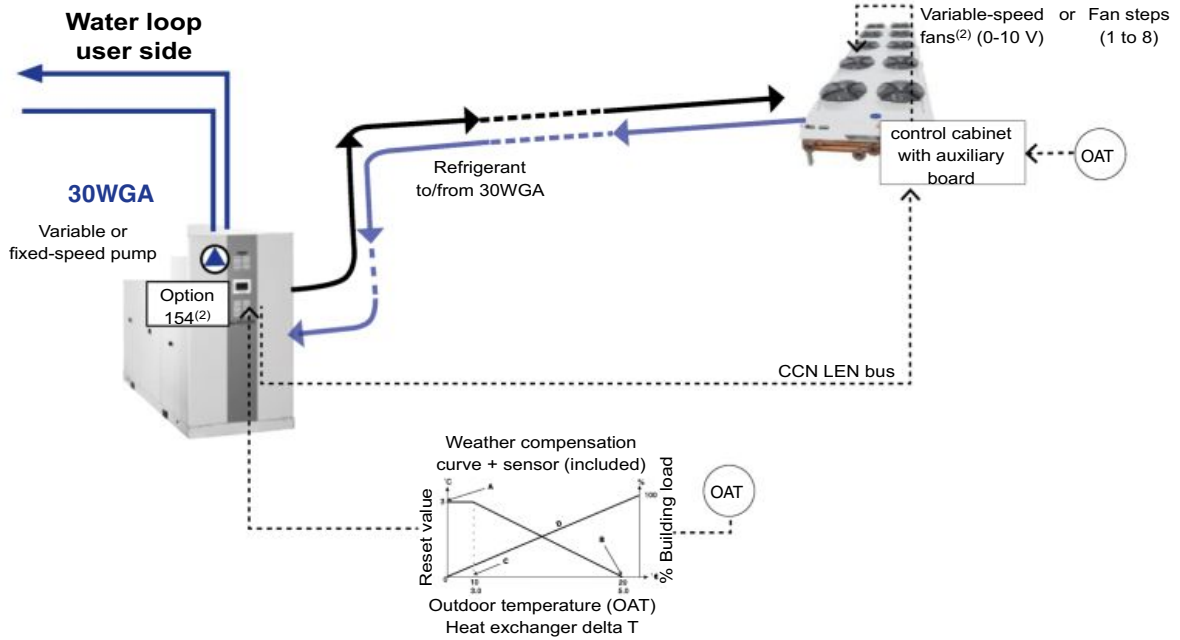

**Legend**

- CCN** Carrier Comfort Network
- LEN** Local equipment network
- OAT** Outside air temperature
- (1) Control board option on 09PE dedicated to 30WG
- (2) Option 154 for connection and communication with 09PE Drycooler
- (3) For correct operation of the unit below 0 °C variable-speed fans are required.



## OPTIONS

Options	No.	Description	Advantages	Use
Medium-temperature brine solution	5B	Low temperature chilled water production down to 0°C with ethylene glycol and propylene glycol.	Covers specific applications such as ice storage and industrial processes	30WGA 020-190
Low-temperature brine solution	6B	Low temperature glycol solution production down to -12 °C with ethylene glycol	Covers specific applications such as ice storage and industrial processes	30WG 020-190
Soft Starter	25	Electronic starter on each compressor	Reduced start-up current	30WG 020-190 30WGA 020-190
Master/slave operation	58	Unit equipped with supplementary water outlet temperature sensor kit to be field-installed allowing master/slave operation of two units connected in parallel	Optimised operation of two units connected in parrallele operation with operating time equalisation	30WG 020-190 30WGA 020-190
External disconnect handle	70F	The handle of the electrical disconnect switch is on the outside of the unit	Quick access to the unit disconnect switch	30WG 020-190 30WGA 020-190
Evap. single pump power/control circuit	84	Unit equipped with an electrical power and control circuit for one pump evaporator side	Quick and easy installation: the control of fixed speed pumps is embedded in the unit control	30WG 110-190
Cond. single pump power/control circuit	84R	Unit equipped with an electrical power and control circuit for one pump condenser side	Quick and easy installation: the control of fixed speed pumps is embedded in the unit control	30WG 110-190
Condenser insulation	86	Thermal condenser insulation	Minimizes thermal dispersions condenser side (key option for heat pump or heat recovery applications) and allows compliancy with special installation criteria (hot parts insulated)	30WG 020-190
HP single-pump hydraulic module	116R	Single high-pressure water pump, water filter, electronic water flow control, pressure transducers. For more details, refer to the dedicated chapter (expansion tank not included.Option with built-in safety hydraulic components available.)	Easy and fast installation (plug & play)	30WG 110-190 30WGA 110-190
LP evap. single-pump	116T	Evaporator hydraulic module equipped with low pressure fixed-speed pump, drain valve, air vent and pressure sensors. For more details, refer to the dedicated chapter (expansion tank not included.Option with built-in safety hydraulic components available.)	Easy and fast installation (plug & play)	30WG 020-190 30WGA 020-190
HP evap. variable-speed single-pump	116V	Evaporator hydraulic module equipped with high-pressure variable-speed pump, drain valve, air vent and pressure sensors. For more details, refer to the dedicated chapter (expansion tank not included.Option with built-in safety hydraulic components available.)	Easy and fast installation (plug & play), significant pumping energy cost savings (more than two-thirds), tighter water flow control, improved sytem reliability	30WG 020-190 30WGA 020-190
HP VSD dual-pump hydraulic mod.	116W	Dual high-pressure water pump with variable speed drive (VSD), pressure transducers. Multiple possibilities of water flow control. For more details, refer to the dedicated chapter (expansion tank not included Option with built-in safety hydraulic components available)	Easy and fast installation (plug & play), significant pumping energy cost savings (more than two-thirds), tighter water flow control, improved sytem reliability	30WG 110-190 30WGA 110-190
LP VSD single-pump	116Y	Evaporator hydraulic module equipped with low -pressure variable-speed pump, drain valve, air vent and pressure sensors. For more details, refer to the dedicated chapter (expansion tank not included.Option with built-in safety hydraulic components available.)	Easy and fast installation (plug & play), significant pumping energy cost savings (more than two-thirds), tighter water flow control, improved sytem reliability	30WG 110-190 30WGA 110-190
Lon gateway	148D	Two-directional communication board complying with Lon Talk protocol	Connects the unit by communication bus to a building management system	30WG 020-190 30WGA 020-190
Bacnet over IP	149	Two-directional high-speed communication using BACnet protocol over Ethernet network (IP)	Easy and high-speed connection by ethernet line to a building management system. Allows access to multiple unit parameters	30WG 20-190 30WGA 020-190
Modbus over IP and RS485	149B	Bi-directional high-speed communication using Modbus protocol over Ethernet network (IP)	Easy and high-speed connection by ethernet line to a building management system. Allows access to multiple unit parameters	30WG 020-190 30WGA 020-190

## OPTIONS

Options	No.	Description	Advantages	Use
Built-in DHW & space heating control	153	Control board factory-installed on the unit, control using weather compensation, control of supplementary electric heater (4 stages) or boiler, needle valve for domestic hot-water production with programmable time schedule.	Permits easy control of a basic heating system	30WG 020-190
Specific dry cooler control	154	Dedicated connection and software for 09PE dry cooler management. For 09PE dry cooler need to select the option control cabinet manage by the chiller	Permits the use of an energy-efficient plug-and-play system	30WG 020-190
Condenser control	154	Control box for communication with the condenser via a bus. For OPERA condenser need to select the cabinet with option control cabinet manage by the chiller Connect'Touch control	Permits the use of an energy-efficient plug-and-play system	30WGA 020-190
Compliance with Russian regulations	199	EAC certification	Conformance with Russian regulations	30WG 020-190 30WGA 020-190
Insulation of the evap. in/out ref.lines	256	Thermal insulation of the evaporator entering/leaving refrigerant lines with flexible, anti-UV insulant	Prevents condensation on the evaporator entering/leaving refrigerant lines	30WG 020-190 30WGA 020-190
Low noise level	257	Compressor sound enclosure	Reduced sound emissions	30WG 020-190 30WGA 020-190
Very low sound level	258	Enhanced sound insulation of main noise sources (Material classified CD0S2 fire class according to Euroclass 13-501).	6 dB(A) quieter than standard . Refer to the physical data table for detailed values	30WG 020-090 30WGA 020-090
Evaporator screw connection sleeves kit	264	Evaporator inlet/outlet screw connection sleeves	Allows unit connection to a screw connector	30WG 020-140 30WGA 020-140
Condenser screw connection sleeves kit	265	Condenser inlet/outlet screw connection sleeves	Allows unit connection to a screw connector	30WG 020-140
Welded evaporator connection kit	266	Victaulic piping connections with welded joints	Easy installation	30WG 020-190 30WGA 020-190
Welded condenser water connection kit	267	Victaulic piping connections with welded joints	Easy installation	30WG 020-190
HP single-pump, cond. side	270R	Condenser hydraulic module equipped with high pressure fixed-speed pump, drain valve, air vent and pressure sensors. Built-in safety hydraulic components available in option.	Easy and fast installation (plug & play)	30WG 110-190
LP single-pump, cond. side	270T	Condenser hydraulic module equipped with low pressure fixed-speed pump, drain valve, air vent and pressure sensors. Built-in safety hydraulic components available in option.	Easy and fast installation (plug & play)	30WG 020-190
HP cond. variable-speed single-pump	270V	Condenser hydraulic module equipped with high-pressure variable-speed pump, drain valve, air vent and pressure sensors. (expansion tank not included) Built-in safety hydraulic components available in option.	Easy and fast installation (plug & play), reduced power consumption of the water circulation pump	30WG 020-190
HP cond. variable-speed dual-pump	270W	Condenser hydraulic module equipped with dual high-pressure variable-speed pump, drain valve, air vent and pressure sensors. (expansion tank not included) Built-in safety hydraulic components available in option.	Easy and fast installation (plug & play), reduced power consumption of the water circulation pump	30WG 110-190
LP cond. variable-speed single-pump	270Y	Condenser hydraulic module equipped with low-pressure variable-speed pump, drain valve, air vent and pressure sensors. (expansion tank not included) Built-in safety hydraulic components available in option.	Easy and fast installation (plug & play), reduced power consumption of the water circulation pump	30WG 110-190
Unit stackable for operation	273	Unit stackable for operation	Reduced footprint size	30WG 020-090 30WGA 020-090

## OPTIONS

Options	No.	Description	Advantages	Use
water connection at the top	274	Customer water connection at the top of the unit	Reduced footprint size	30WG 020-190 30WGA 020-190
Replaceable filter drier	277	Filter drier with cartridge to replace hermetic filter	Easy filter replacement without emptying the refrigerant circuit	30WGA 020-190
Safety hydraulic components, evap. side	293	Screen filter, expansion tank and relief valve integrated in the evaporator hydraulic module	Easy and fast installation (plug & play), operating safety	30WG 020-190 30WGA 020-190
Safety hydraulic components, cond. side	293A	Screen filter, expansion tank and relief valve integrated in the condenser hydraulic module	Easy and fast installation (plug & play), operating safety	30WG 020-190
Set point adjustment by 4-20mA signal	311	Connections to allow a 4-20mA signal input	Easy energy management, allow to adjust set point by a 4-20mA external signal	30WG 020-190 30WGA 020-190
External temperature sensor	312	External temperature sensor control for using weather compensation	Allow to adjust set point using weather compensation and define autorisation operation mode to external temperature	30WG 020-190 30WGA 020-190
Free Cooling dry cooler management	313	Control & connections to a Free Cooling Drycooler 09PE or 09VE fitted with option FC control box	Easy system management, Extended control capabilities to a drycooler used in Free Cooling mode	30WG 020-190 30WGA 020-190

PHYSICAL DATA, 30WG UNITS , SIZES 020 TO 090

30WG			020	025	030	035	040	045	050	060	070	080	090		
<b>Heating</b>															
<b>Standard unit Full load performances*</b>	HW1	Nominal capacity	kW	30	35	38	44	50	56	70	77	89	101	114	
		COP	kW/kW	5,53	5,53	5,49	5,52	5,49	5,51	5,58	5,48	5,53	5,46	5,50	
	HW2	Nominal capacity	kW	29	33	36	43	49	54	68	74	85	97	108	
		COP	kW/kW	4,34	4,37	4,35	4,36	4,40	4,35	4,39	4,35	4,32	4,40	4,32	
	HW3	Nominal capacity	kW	28	33	35	41	47	52	65	73	81	93	103	
		COP	kW/kW	3,59	3,63	3,61	3,60	3,67	3,61	3,58	3,62	3,54	3,70	3,56	
<b>Standard unit Seasonal energy efficiency**</b>	HW1	SCOP <sub>30/35°C</sub>	kW/kW	5,46	5,45	5,36	5,40	5,35	5,38	6,12	6,08	6,09	6,11	6,09	
		ηs heat <sub>30/35°C</sub>	%	211	210	206	208	206	207	237	235	235	236	235	
	HW3	<b>SCOP<sub>47/55°C</sub></b>	<b>kW/kW</b>	<b>4,36</b>	<b>4,37</b>	<b>4,34</b>	<b>4,37</b>	<b>4,40</b>	<b>4,34</b>	<b>4,91</b>	<b>4,96</b>	<b>4,85</b>	<b>5,08</b>	<b>4,91</b>	
		<b>ηs heat<sub>47/55°C</sub></b>	<b>%</b>	<b>167</b>	<b>167</b>	<b>166</b>	<b>167</b>	<b>168</b>	<b>166</b>	<b>188</b>	<b>190</b>	<b>186</b>	<b>195</b>	<b>188</b>	
			P <sub>rated</sub>	kW	32	37	40	47	54	59	75	83	93	106	118
			Energy labelling		A++	A++	A++	A++	A++	A++	-	-	-	-	-
<b>Cooling</b>															
<b>Standard unit Full load performances*</b>	CW1	Nominal capacity	kW	25	29	32	37	42	47	58	63	74	84	95	
		EER	kW/kW	4,72	4,72	4,69	4,73	4,69	4,72	4,72	4,65	4,69	4,65	4,68	
			Eurovent class		B	B	B	B	B	B	B	B	B	B	
	CW2	Nominal capacity	kW	34	39	43	50	57	66	79	86	102	113	129	
EER		kW/kW	6,42	6,10	6,03	6,04	5,90	6,06	6,12	5,95	6,19	5,93	6,13		
		Eurovent class		A	A	A	A	A	A	A	A	A	A		
<b>Standard unit Seasonal energy efficiency**</b>		SEER <sub>12/7°C</sub> Comfort low temp.	kW/kW	4,94	4,94	4,83	4,87	4,85	4,88	5,70	5,62	5,58	5,72	5,68	
		SEPR <sub>12/7°C</sub> Process high temp.	kW/kW	6,42	6,44	6,26	6,22	6,26	6,31	6,63	6,50	6,48	6,59	6,62	
<b>Unit with option 6B Seasonal energy efficiency**</b>		SEPR <sub>-2/-8°C</sub> Process medium temp.***	kWh/kWh	3,92	4,26	4,43	4,34	4,47	4,01	4,12	4,73	4,55	4,78	4,76	
<b>Integrated part load value</b>		IPLV.SI	kW/kW	5,840	5,850	5,760	5,780	5,770	5,820	6,580	6,680	6,560	6,810	6,720	
<b>Operating weight<sup>(1)</sup></b>			kg	191	200	200	207	212	220	386	392	403	413	441	
<b>Operating weight with option 258<sup>(1)</sup></b>			kg	198	207	207	214	219	227	399	405	416	426	454	
<b>Sound levels<sup>(2)</sup></b>															
		Sound power level, standard unit	dB(A)	67	68	69	69	70	70	72	72	72	73	73	
		Sound power level, option 257	dB(A)	65	66	66	67	68	68	68	69	69	69	70	
		Sound power level, option 258	dB(A)	61	62	63	63	64	64	66	66	66	67	67	
		Sound power level, option 257 + 258	dB(A)	60	62	62	62	64	63	65	65	65	66	66	
<b>Dimensions, standard unit<sup>(3)</sup></b>															
		Width	mm	600	600	600	600	600	600	880	880	880	880	880	
		Length	mm	1044	1044	1044	1044	1044	1044	1474	1474	1474	1474	1474	
		Height	mm	901	901	901	901	901	901	901	901	901	901	901	

\* In accordance with standard EN14511-3:2022  
 \*\* In accordance with standard EN14825:2022, average climate  
 \*\*\* With EG 30%  
 HW1 Heating mode conditions: Evaporator entering/leaving water temperature 10°C/7°C, condenser entering/leaving water temperature 30°C/35°C, evaporator and condenser fouling factor 0 m2. k/W  
 HW2 Heating mode conditions: Evaporator entering/leaving water temperature 10°C/7°C, condenser entering/leaving water temperature 40°C/45°C, evaporator and condenser fouling factor 0 m2. k/W  
 HW3 Heating mode conditions: Evaporator entering/leaving water temperature 10°C/7°C, condenser entering/leaving water temperature 47°C/55°C, evaporator and condenser fouling factor 0 m2. k/W  
 CW1 Cooling mode conditions: Evaporator water entering/leaving temperature 12°C/7°C, condenser entering/leaving water temperature 30°C/35°C, evaporator and condenser fouling factor 0 m2.K/W  
 CW2 Cooling mode conditions: Evaporator water entering/leaving temperature 23°C/18°C, condenser entering/leaving water temperature 30°C/35°C, evaporator and condenser fouling factor 0 m2.K/W  
 ηs heat<sub>30/35°C</sub>& SCOP<sub>30/35°C</sub> Values calculated in accordance with EN14825:2022  
 ηs heat<sub>47/55°C</sub>& SCOP<sub>47/55°C</sub> **Bold values compliant to Ecodesign regulation: (EU) No 813/2013 for Heat Pump application**  
 SEER<sub>12/7°C</sub>& SEPR<sub>12/7°C</sub> Values calculated in accordance with EN14825:2022  
 SEPR<sub>-2/-8°C</sub> Values calculated in accordance with EN14825:2022  
 - Not applicable  
 IPLV.SI Calculations according to standard performances AHRI 551-591 (SI)  
 (1) Weight shown is a guideline only. Please refer to the unit nameplate  
 (2) In dB ref=10<sup>-12</sup> W, (A) weighting. Declared dualnumber noise emission values in accordance with ISO 4871 (with an associated uncertainty of +/-3dB(A)). Measured in accordance with ISO 9614-1.  
 (3) The dimensions shown are for the standard unit. For other unit types please refer to the dimensional drawings.



Eurovent certified values

**PHYSICAL DATA, 30WG UNITS , SIZES 020 TO 090**

30WG		020	025	030	035	040	045	050	060	070	080	090
<b>Compressors</b>		Hermetic scroll 48.3 r/s										
Quantity		1	1	1	1	1	1	2	2	2	2	2
Number of capacity stages		1	1	1	1	1	1	2	2	2	2	2
Minimum capacity	%	100	100	100	100	100	100	50	50	50	50	50
<b>Refrigerant<sup>(1)</sup></b>		R410A (GWP=2088 Following ARI4)										
Charge, standard unit	kg	3,5	3,5	3,6	3,7	4,0	4,6	7,6	7,8	7,9	8,7	11,5
	teqCO <sub>2</sub>	7,2	7,3	7,4	7,6	8,2	9,5	15,9	16,3	16,5	18,2	24
<b>Capacity control</b>		SmartVu™										
<b>Evaporator</b>		Direct-expansion plate heat exchanger										
Water volume	l	3,3	3,6	3,6	4,2	4,6	5,0	8,4	9,2	9,6	10,4	12,5
Water connections		Victaulic										
Inlet/outlet	in	1,5	1,5	1,5	1,5	1,5	1,5	2	2	2	2	2
Max. water-side operating pressure without hydraulic module	kPa	1000	1000	1000	1000	1000	1000	1000	1000	1000	1000	1000
<b>Condenser</b>		Plate heat exchanger										
Net water volume	l	3,3	3,6	3,6	4,2	4,6	5,0	8,4	9,2	9,6	10,4	12,5
Water connections		Victaulic										
Inlet/outlet	in	1,5	1,5	1,5	1,5	1,5	1,5	2	2	2	2	2
Max. water-side operating pressure without hydraulic module	kPa	1000	1000	1000	1000	1000	1000	1000	1000	1000	1000	1000
<b>Chassis paint color</b>		Color code: RAL7035										

(1) Weight shown is a guideline only. Please refer to the unit nameplate



## PHYSICAL DATA, 30WG UNITS, SIZES 110 TO 190

30WG			110	120	140	150	170	190	
<b>Heating</b>									
<b>Standard unit</b> Full load performances*	HW1	Nominal capacity	kW	135	152	175	183	207	238
		COP	kW/kW	5,50	5,50	5,42	5,58	5,59	5,50
	HW2	Nominal capacity	kW	131	148	163	174	197	218
		COP	kW/kW	4,44	4,45	4,38	4,41	4,50	4,38
	HW3	Nominal capacity	kW	125	140	160	166	187	214
		COP	kW/kW	3,56	3,45	3,54	3,55	3,44	3,53
<b>Standard unit</b> Seasonal energy efficiency**	HW1	SCOP <sub>30/35°C</sub>	kW/kW	6,31	6,37	6,31	6,31	6,32	6,18
		$\eta_s$ heat <sub>30/35°C</sub>	%	244	247	244	244	245	239
	HW3	SCOP <sub>47/55°C</sub>	kW/kW	<b>5,05</b>	<b>5,09</b>	<b>5,05</b>	<b>5,02</b>	<b>5,17</b>	<b>4,96</b>
		$\eta_s$ heat <sub>47/55°C</sub>	%	<b>194</b>	<b>196</b>	<b>194</b>	<b>193</b>	<b>199</b>	<b>190</b>
		P <sub>rated</sub>	kW	143	161	178	191	216	239
	<b>Cooling</b>								
<b>Standard unit</b> Full load performances*	CW1	Nominal capacity	kW	115	130	144	153	172	192
		EER	kW/kW	4,79	4,77	4,70	4,83	4,78	4,79
		Eurovent class		B	B	B	B	B	B
	CW2	Nominal capacity	kW	155	176	196	207	231	262
		EER	kW/kW	6,20	6,10	6,01	6,23	5,97	6,14
		Eurovent class		A	A	A	A	A	A
<b>Standard unit</b> Seasonal energy efficiency**		SEER <sub>12/7°C</sub> Comfort low temp.	kW/kW	6,12	6,24	6,17	5,97	6,06	5,96
		SEPR <sub>12/7°C</sub> Process high temp.	kWh/kWh	6,98	7,13	6,90	6,54	6,62	6,41
<b>Unit with option 6B</b> Seasonal energy efficiency**		SEPR <sub>2/-8°C</sub> Process medium temp.***	kWh/kWh	4,01	4,40	4,35	4,52	4,65	4,45
<b>Integrated part load value</b>		IPLV.SI	kW/kW	6,860	6,980	6,900	6,820	6,890	6,820
<b>Operating weight (1)</b>			kg	707	733	758	841	877	908
<b>Sound levels (2)</b>									
		Sound power level, standard unit	dB(A)	76	77	78	76	77	78
		Sound power level, option 257	dB(A)	73	74	75	73	74	75
<b>Dimensions, standard unit (3)</b>									
		Width	mm	880	880	880	880	880	880
		Length	mm	1583	1583	1583	1583	1583	1583
		Height	mm	1574	1574	1574	1574	1574	1574
<b>Compressors</b>									
		Quantity		Hermetic scroll 48.3 r/s					
		Number of capacity stages		3	3	3	4	4	4
		Minimum capacity	%	33	33	33	25	25	25

- \* In accordance with standard EN14511-3:2022  
 \*\* In accordance with standard EN14825:2022, average climate  
 \*\*\* With EG 30%
- HW1 Heating mode conditions: Evaporator entering/leaving water temperature 10°C/7°C, condenser entering/leaving water temperature 30°C/35°C, evaporator and condenser fouling factor 0 m2. k/W  
 HW2 Heating mode conditions: Evaporator entering/leaving water temperature 10°C/7°C, condenser entering/leaving water temperature 40°C/45°C, evaporator and condenser fouling factor 0 m2. k/W  
 HW3 Heating mode conditions: Evaporator entering/leaving water temperature 10°C/7°C, condenser entering/leaving water temperature 47°C/55°C, evaporator and condenser fouling factor 0 m2. k/W  
 CW1 Cooling mode conditions: Evaporator water entering/leaving temperature 12°C/7°C, condenser entering/leaving water temperature 30°C/35°C, evaporator and condenser fouling factor 0 m2.K/W  
 CW2 Cooling mode conditions: Evaporator water entering/leaving temperature 23°C/18°C, condenser entering/leaving water temperature 30°C/35°C, evaporator and condenser fouling factor 0 m2.K/W
- $\eta_s$  heat<sub>30/35°C</sub> & SCOP<sub>30/35°C</sub> Values calculated in accordance with EN14825:2022  
 $\eta_s$  heat<sub>47/55°C</sub> & SCOP<sub>47/55°C</sub> **Bold values compliant to Ecodesign regulation: (EU) No 813/2013 for Heat Pump application**  
 SEER<sub>12/7°C</sub> & SEPR<sub>12/7°C</sub> Values calculated in accordance with EN14825:2022  
 SEPR<sub>2/-8°C</sub> Values calculated in accordance with EN14825:2022  
 IPLV.SI Calculations according to standard performances AHRI 551-591 (SI).  
 (1) Weight shown is a guideline only. Please refer to the unit nameplate  
 (2) In dB ref=10<sup>-12</sup> W, (A) weighting. Declared dualnumber noise emission values in accordance with ISO 4871 (with an associated uncertainty of +/-3dB(A)). Measured in accordance with ISO 9614-1.  
 (3) The dimensions shown are for the standard unit. For other unit types please refer to the dimensional drawings.



Eurovent certified values

**PHYSICAL DATA, 30WG UNITS, SIZES 110 TO 190**

30WG		110	120	140	150	170	190
<b>Refrigerant <sup>(1)</sup></b>		R410A (GWP=2088 Following ARI4)					
Charge, standard unit	kg	13,3	14,5	15,6	21,0	23,0	24,2
	teqCO <sub>2</sub>	27,8	30,3	32,6	43,8	48,0	50,5
<b>Capacity control</b>		SmartVu™					
<b>Evaporator</b>		Direct-expansion plate heat exchanger					
Water volume	l	15,18	17,35	19,04	23,16	26,52	29,05
Water connections	-	Victaulic					
Inlet/outlet	in	2 1/2	2 1/2	2 1/2	3	3	3
Max. water-side operating pressure without hydraulic module	kPa	1000	1000	1000	1000	1000	1000
<b>Condenser</b>		Plate heat exchanger					
Net water volume	l	15,18	17,35	19,04	23,16	26,52	29,05
Water connections	-	Victaulic					
Inlet/outlet	in	2 1/2	2 1/2	2 1/2	3	3	3
Max. water-side operating pressure without hydraulic module	kPa	1000	1000	1000	1000	1000	1000
<b>Chassis paint color</b>		Color code: RAL7035					

(1) Weight shown is a guideline only. Please refer to the unit nameplate

## PHYSICAL DATA, 30WGA UNITS

30WGA			020	025	030	035	040	045	050	060	070	080	090	
<b>Standard unit</b> Full load performances*	CS1	Nominal capacity	kW	22,8	27	29,1	34	39,2	42,7	54,5	59,1	67,5	78,2	87,4
		EER	kW/kW	3,70	3,76	3,68	3,73	3,75	3,70	3,70	3,66	3,64	3,81	3,77
	CS2	Nominal capacity	kW	31,8	37,6	40,3	47	53,2	61,3	74,5	81,2	94,9	108	121
		EER	kW/kW	5,35	5,25	5,11	5,09	4,99	5,15	5,16	5,15	5,18	5,26	5,13
<b>Operating weight<sup>(1)</sup></b>			kg	164	171	171	177	180	185	321	324	332	339	354
<b>Operating weight with option 258<sup>(1)</sup></b>			kg	171	178	178	184	187	192	334	337	345	352	367
<b>Sound levels<sup>(2)</sup></b>														
Sound power level, standard unit			dB(A)	67	68	69	69	70	70	72	72	72	73	73
Sound power level, option 257			dB(A)	65	66	66	67	68	68	68	69	69	69	70
Sound power level, option 258			dB(A)	61	62	63	63	64	64	66	66	66	67	67
Sound power level, option 257 + 258			dB(A)	60	62	62	62	64	63	65	65	65	66	66
<b>Dimensions, standard unit<sup>(3)</sup></b>														
Width			mm	600	600	600	600	600	600	880	880	880	880	880
Length			mm	1044	1044	1044	1044	1044	1044	1474	1474	1474	1474	1474
Height			mm	901	901	901	901	901	901	901	901	901	901	901
<b>Compressors</b>				Hermetic scroll 48.3 r/s										
Circuit A				1	1	1	1	1	1	2	2	2	2	2
Circuit B				-	-	-	-	-	-	-	-	-	-	-
Number of capacity stages				1	1	1	1	1	1	2	2	2	2	2
Minimum capacity			%	100	100	100	100	100	100	50	50	50	50	50
<b>Refrigerant</b>				R410A (GWP=2088 Following ARI4)										
<b>Capacity control</b>				SmartVu™										
<b>Evaporator</b>				Direct-expansion plate heat exchanger										
Water volume			l	3,3	3,6	3,6	4,2	4,6	5,0	8,4	9,2	9,6	10,4	12,5
<b>Water connections</b>				Victaulic										
Inlet/outlet			in	1,5	1,5	1,5	1,5	1,5	1,5	2	2	2	2	2
Max. water-side operating pressure without hydraulic module			kPa	1000	1000	1000	1000	1000	1000	1000	1000	1000	1000	1000
<b>Refrigerant connections</b>														
Discharge line diameter			in	7/8	7/8	7/8	7/8	7/8	7/8	1-1/8	1-1/8	1-1/8	1-1/8	1-1/8
Liquid line diameter			in	5/8	5/8	5/8	5/8	5/8	5/8	7/8	7/8	7/8	7/8	7/8
Chassis paint color				Color code: RAL7035										

- \* In accordance with standard EN14511-3:2022. Refrigerant piping equivalent length (without drier and valves) = 3 m.
- CS1 Cooling mode conditions: evaporator entering/leaving water temperature 12 °C/7 °C, saturated condensing temperature 45 °C, subcooling 5 K, evaporator fouling factor 0 m<sup>2</sup>K/W.
- CS2 Cooling mode conditions: evaporator entering/leaving water temperature 23 °C/18 °C, saturated condensing temperature 45 °C, subcooling 5 K, evaporator fouling factor 0 m<sup>2</sup>K/W.
- (1) Weight shown is a guideline only. Please refer to the unit nameplate
- (2) In dB ref=10<sup>-12</sup> W, (A) weighting. Declared dualnumber noise emission values in accordance with ISO 4871 (with an associated uncertainty of +/-3dB(A) Measured in accordance with ISO 9614-1.
- (3) The dimensions shown are for the standard unit. For other unit types please refer to the dimensional drawings.

## PHYSICAL DATA, 30WGA UNITS

30WGA				110	120	140	150	170	190	
<b>Standard unit</b> Full load performances*	CS1	Nominal capacity	kW	106	119	132	140	159	175	
		EER	kW/kW	3,78	3,78	3,72	3,75	3,81	3,72	
	CS2	Nominal capacity	kW	146	166	185	195	218	247	
		EER	kW/kW	5,24	5,17	5,12	5,32	5,17	5,26	
<b>Operating weight<sup>(1)</sup></b>				kg	762	787	814	909	944	975
<b>Sound levels<sup>(2)</sup></b>										
Sound power level				dB(A)	76	77	78	76	77	78
Sound power level, option 257				dB(A)	73	74	75	73	74	75
<b>Dimensions, standard unit<sup>(3)</sup></b>										
Width				mm	880	880	880	880	880	880
Length				mm	1583	1583	1583	1583	1583	1583
Height				mm	1574	1574	1574	1574	1574	1574
<b>Compressors</b>					Hermetic scroll 48.3 r/s					
Circuit A					3	3	3	4	4	4
Number of capacity stages					3	3	3	4	4	4
Minimum capacity				%	33	33	33	25	25	25
<b>Refrigerant</b>					R410A (GWP=2088 Following ARI4)					
<b>Capacity control</b>					SmartVu™					
<b>Evaporator</b>					Direct-expansion plate heat exchanger					
Water volume				l	15,18	17,35	19,04	23,16	26,52	29,05
Water connections					Victaulic					
Inlet/outlet				in	2 1/2	2 1/2	2 1/2	3	3	3
Max. water-side operating pressure without hydraulic module					1000	1000	1000	1000	1000	1000
<b>Refrigerant connections</b>										
Discharge line diameter				in	1"3/8	1"3/8	1"3/8	1"1/8	1"1/8	1"1/8
Liquid line diameter				in	7/8"	7/8"	7/8"	7/8"	7/8"	7/8"
<b>Chassis paint color</b>					Color code: RAL7035					

- \* In accordance with standard EN14511-3:2022. Refrigerant piping equivalent length (without drier and valves) = 3 m.
- CS1 Cooling mode conditions: evaporator entering/leaving water temperature 12 °C/7 °C, saturated condensing temperature 45 °C, subcooling 5 K, evaporator fouling factor 0 m<sup>2</sup>K/W.
- CS2 Cooling mode conditions: evaporator entering/leaving water temperature 23 °C/18 °C, saturated condensing temperature 45 °C, subcooling 5 K, evaporator fouling factor 0 m<sup>2</sup>K/W.
- (1) Weight shown is a guideline only. Please refer to the unit nameplate
- (2) In dB ref=10<sup>-12</sup> W, (A) weighting. Declared dual number noise emission values in accordance with ISO 4871 (with an associated uncertainty of +/- 3dB(A)). Measured in accordance with ISO 9614-1.
- (3) The dimensions shown are for the standard unit. For other unit types please refer to the dimensional drawings.

## ELECTRICAL DATA

30WG without hydraulic module		020	025	030	035	040	045	050	060	070	080	090	
<b>Power circuit</b>													
Nominal voltage	V-ph-Hz	400-3-50											
Voltage range	V	360-440											
<b>Control circuit supply</b>													
24 V, via internal transformer													
<b>Maximum start-up current draw (Un)<sup>(1)</sup></b>													
Standard unit	A	98	142	142	147	158	197	161	162	170	183	226	
Unit with electronic starter option	A	53,9	78,1	78,1	80,9	86,9	108,4	96,8	97,9	104,1	112,3	137,4	
<b>Unit power factor at maximum capacity<sup>(2)</sup></b>													
		0,9	0,8	0,9	0,9	0,9	0,9	0,8	0,9	0,9	0,9	0,9	
<b>Maximum operating power input<sup>(2)</sup></b>													
		kW	9,2	10,8	11,7	13,7	15,1	17,1	21,5	23,3	27,3	30,3	34,2
<b>Nominal unit operating current draw<sup>(3)</sup></b>													
		A	10,5	13,2	13,8	15,6	16,2	20,2	26,4	27,6	31,2	32,4	40,4
<b>Maximum operating current draw (Un)<sup>(4)</sup></b>													
		A	15,6	18,7	19,8	23,2	25,4	29	37,4	39,6	46,4	50,8	58
<b>Maximum operating current draw (Un-10%)*</b>													
		A	17,3	20,8	22	25,8	28,2	32,2	41,6	44	51,6	56,4	64,4
<b>Customer-side unit power reserve</b>													
Customer reserve at the 24 V control power circuit													
<b>Short-circuit stability and protection</b>													
See table below "Short-circuit stability current"													

- (1) Maximum instantaneous start-up current at operating limit values (maximum operating current of the smallest compressor(s) + locked rotor current or limited start-up current of the largest compressor).  
(2) Maximum power input at the unit operating limits.  
(3) Values obtained at standardised Eurovent conditions: evaporator entering/leaving water temperature 12 °C/7 °C, condenser entering/leaving water temperature 30 °C/ 35 °C.  
(4) Maximum unit operating current at maximum unit power input and 400 V.  
\* Maximum unit operating current at maximum unit power input and 360 V.

30WG without hydraulic module		110	120	140	150	170	190	
<b>Power circuit</b>								
Nominal voltage	V-ph-Hz	400-3-50						
Voltage range	V	360-440						
<b>Control circuit supply</b>								
24 V, via internal transformer								
<b>Maximum start-up current draw (Un)<sup>(1)</sup></b>								
Standard unit	A	193,4	208,8	255	216,6	234,2	284	
Unit with electronic starter option	A	127,3	137,7	166,4	150,5	163,1	195,4	
<b>Unit power factor at maximum capacity<sup>(2)</sup></b>								
		0,87	0,85	0,85	0,87	0,85	0,85	
<b>Maximum operating power input<sup>(2)</sup></b>								
		kW	41	45	51	55	60	68
<b>Nominal unit operating current draw<sup>(3)</sup></b>								
		A	46,8	48,6	60,6	62,4	64,8	80,8
<b>Maximum operating current draw (Un)<sup>(4)</sup></b>								
		A	69,6	76,2	87	92,8	101,6	116
<b>Maximum operating current draw (Un-10%)*</b>								
		A	77,3	84,7	96,7	103,1	112,9	128,9
<b>Customer-side unit power reserve</b>								
Customer reserve at the 24 V control power circuit								
<b>Short-circuit stability and protection</b>								
See table below "Short-circuit stability current"								

- (1) Maximum instantaneous start-up current at operating limit values (maximum operating current of the smallest compressor(s) + locked rotor current or limited start-up current of the largest compressor).  
(2) Maximum power input at the unit operating limits.  
(3) Values obtained at standardised Eurovent conditions: evaporator entering/leaving water temperature 12 °C/7 °C, condenser entering/leaving water temperature 30 °C/ 35 °C.  
(4) Maximum unit operating current at maximum unit power input and 400 V.  
\* Maximum unit operating current at maximum unit power input and 360 V.



## ELECTRICAL DATA

30WGA without hydraulic module		020	025	030	035	040	045	050	060	070	080	090
<b>Power circuit</b>												
Nominal voltage	V-ph-Hz	400-3-50										
Voltage range	V	360-440										
<b>Control circuit supply</b>		24 V, via internal transformer										
<b>Maximum start-up current draw (Un)<sup>(1)</sup></b>												
Standard unit	A	98	142	142	147	158	197	161	162	170	183	226
Unit with electronic starter option	A	53,9	78,1	78,1	80,9	86,9	108,4	96,8	97,9	104,1	112,3	137,4
<b>Unit power factor at maximum capacity<sup>(2)</sup></b>		0,9	0,8	0,9	0,9	0,9	0,9	0,8	0,9	0,9	0,9	0,9
<b>Maximum operating power input<sup>(2)</sup></b>		kW	9,2	10,8	11,7	13,7	15,1	17,1	21,5	23,3	27,3	34,2
<b>Nominal unit operating current draw<sup>(3)</sup></b>		A	11,4	13,8	14,7	16,5	18,1	21,2	27,6	29,4	33,1	42,5
<b>Maximum operating current draw (Un)<sup>(4)</sup></b>		A	15,6	18,7	19,8	23,2	25,4	29	37,4	39,6	46,4	58
<b>Maximum operating current draw (Un-10%)*</b>		A	17,3	20,8	22	25,8	28,2	32,2	41,6	44	51,6	64,4
<b>Customer-side unit power reserve</b>		Customer reserve at the 24 V control power circuit										
<b>Short-circuit stability and protection</b>		See table below "Short-circuit stability current"										

30WGA without hydraulic module		110	120	140	150	170	190
<b>Power circuit</b>							
Nominal voltage	V-ph-Hz	400-3-50					
Voltage range	V	360-440					
<b>Control circuit supply</b>		24 V, via internal transformer					
<b>Maximum start-up current draw (Un)<sup>(1)</sup></b>							
Standard unit	A	193,4	208,8	255	216,6	234,2	284
Unit with electronic starter option	A	127,3	137,7	166,4	150,5	163,1	195,4
<b>Unit power factor at maximum capacity<sup>(2)</sup></b>		0,87	0,85	0,85	0,87	0,85	0,85
<b>Maximum operating power input<sup>(2)</sup></b>		kW	41	45	51	55	68
<b>Nominal unit operating current draw<sup>(3)</sup></b>		A	49,5	54,3	63,6	66	84,8
<b>Maximum operating current draw (Un)<sup>(4)</sup></b>		A	69,6	76,2	87	92,8	116
<b>Maximum operating current draw (Un-10%)*</b>		A	77,3	84,7	96,7	103,1	128,9
<b>Customer-side unit power reserve</b>		Customer reserve at the 24 V control power circuit					
<b>Short-circuit stability and protection</b>		See table below "Short-circuit stability current"					

- (1) Maximum instantaneous start-up current at operating limit values (maximum operating current of the smallest compressor(s) + locked rotor current or limited start-up current of the largest compressor).
- (2) Maximum power input at the unit operating limits.
- (3) Values obtained at the following conditions: evaporator entering/leaving water temperature 12 °C/7 °C, condenser entering/leaving water temperature 45 °C.
- (4) Maximum unit operating current at maximum unit power input and 400 V.
- \* Maximum unit operating current at maximum unit power input and 360 V.

## DIMENSIONS/CLEARANCES

### 30WG 020-045 - standard unit

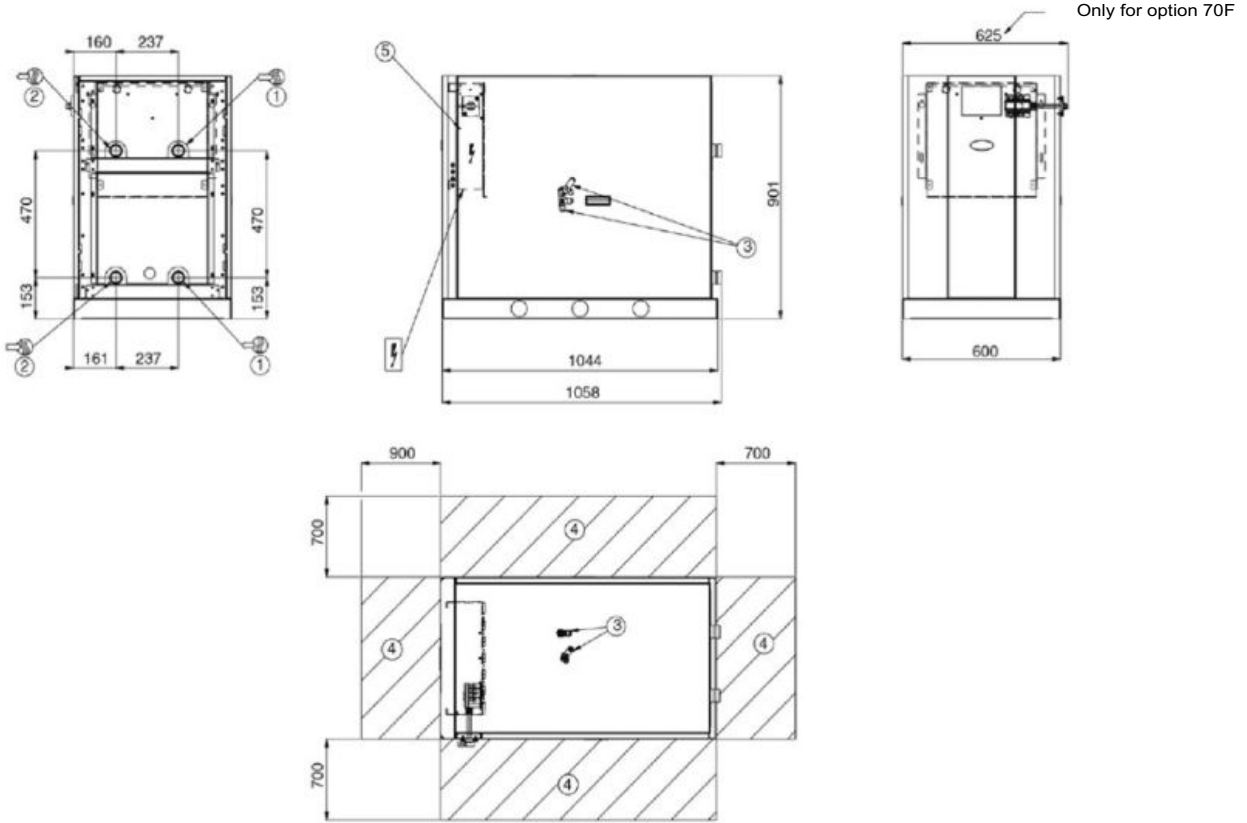

### 30WG 020-045 - unit with top connections (option 274)

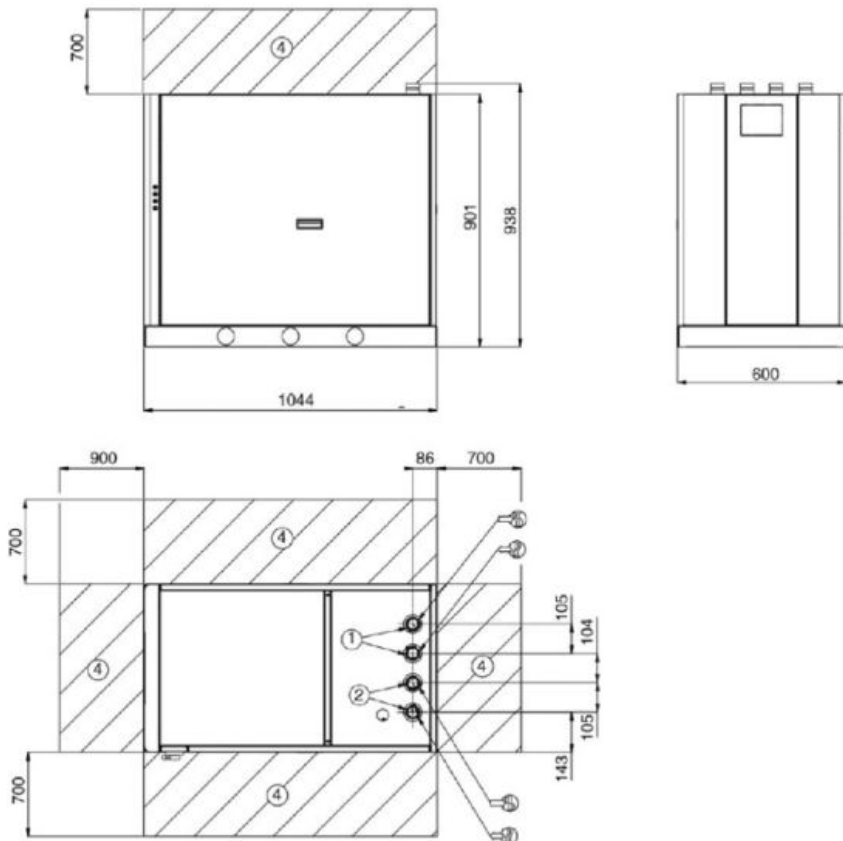

**Legend**

All dimensions are in mm.

- ① Evaporator
- ② Condenser
- ③ Safety valve
- ④ Clearances required for maintenance (see note)
- ⑤ Control box
- Water inlet.
- Water outlet
- Power wiring connection

**NOTE:** Non-contractual drawings. Refer to the certified dimensional drawings available on request, when designing an installation.

## DIMENSIONS/CLEARANCES

### 30WG 020-045 - unit with evaporator hydraulic module (option 116)

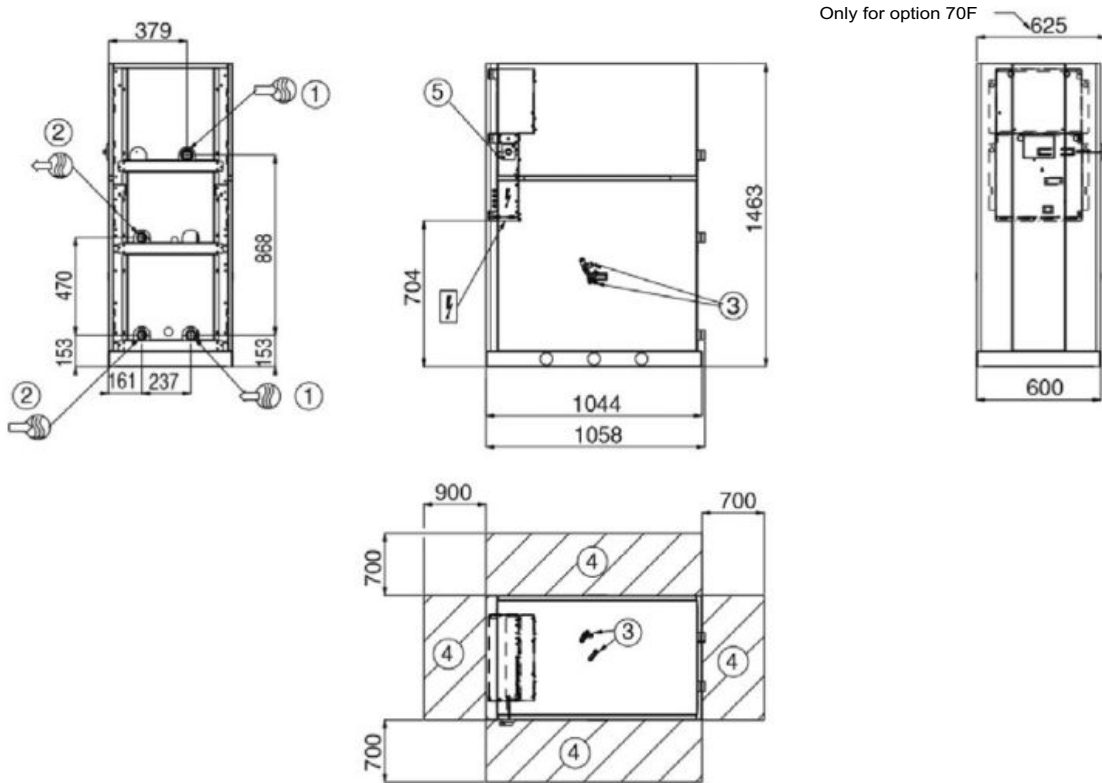

### 30WG 020-045 - unit with condenser hydraulic module (option 270)

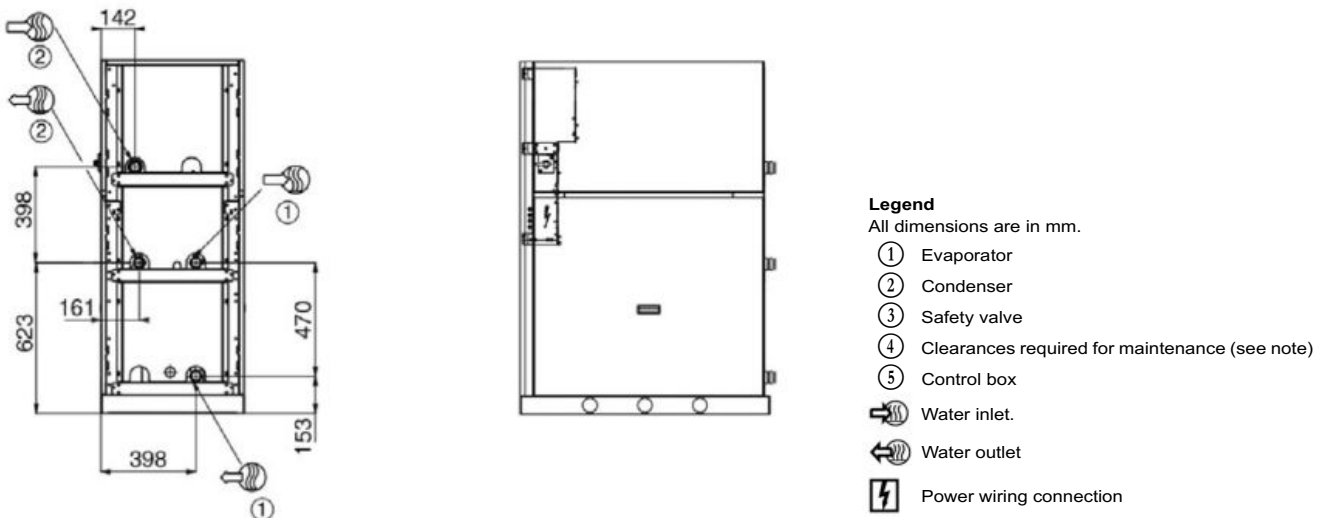

**NOTE:** Non-contractual drawings. Refer to the certified dimensional drawings available on request, when designing an installation.

## DIMENSIONS/CLEARANCES

### 30WG 020-045 - unit with evaporator/condenser hydraulic modules (options 116 + 270)

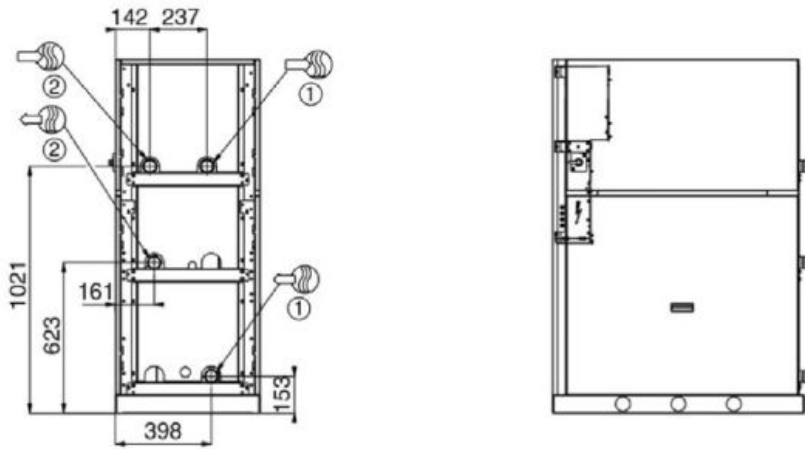

### 30WG 020-045 - unit with hydraulic module and top connections (options 116 + 274 or 270 + 274 or 116 + 270 + 274)

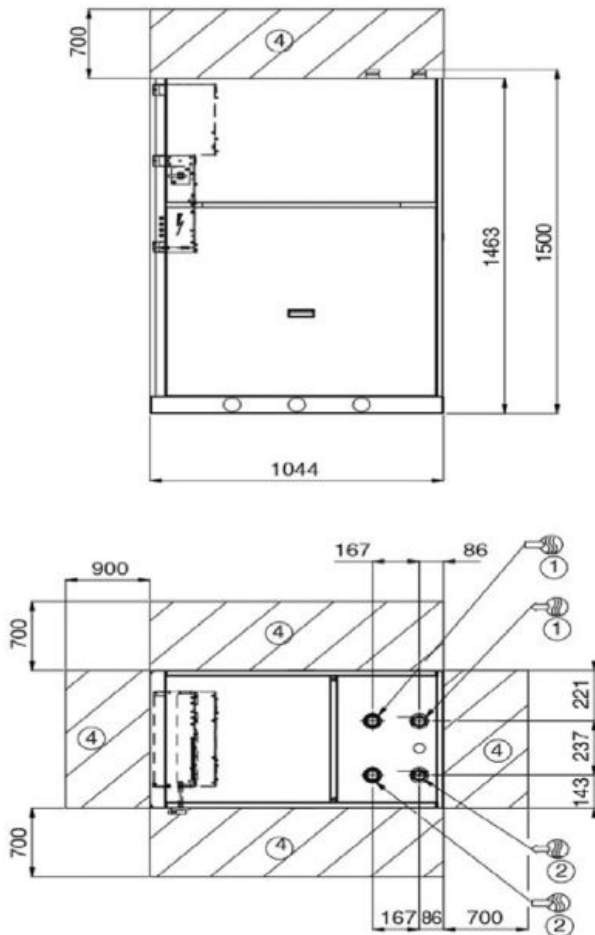

**Legend**

All dimensions are in mm.

- ① Evaporator
- ② Condenser
- ③ Safety valve
- ④ Clearances required for maintenance (see note)
- ⑤ Control box
- Water inlet.
- Water outlet
- Power wiring connection

**NOTE:** Non-contractual drawings. Refer to the certified dimensional drawings available on request, when designing an installation.

## DIMENSIONS/CLEARANCES

### 30WG 020-045 - stackable unit (option 273)

**NOTE:** The water and electrical connections are identical to those of the standard unit.

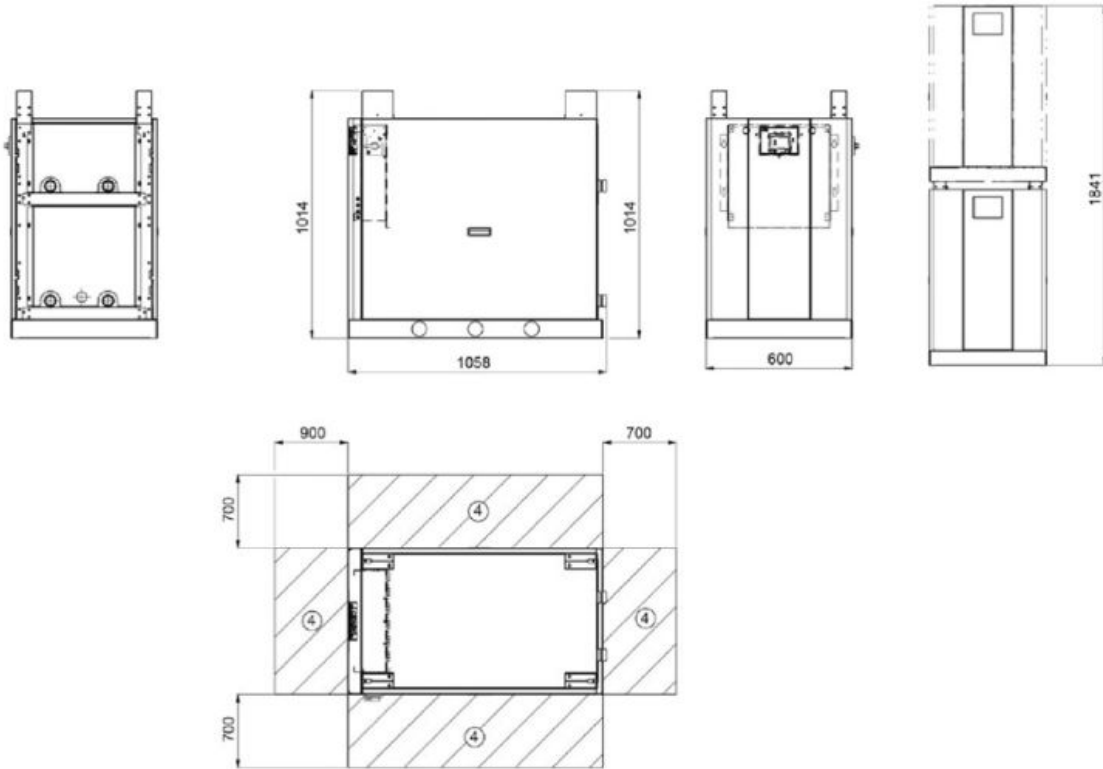

### 30WG 050-090 - standard unit

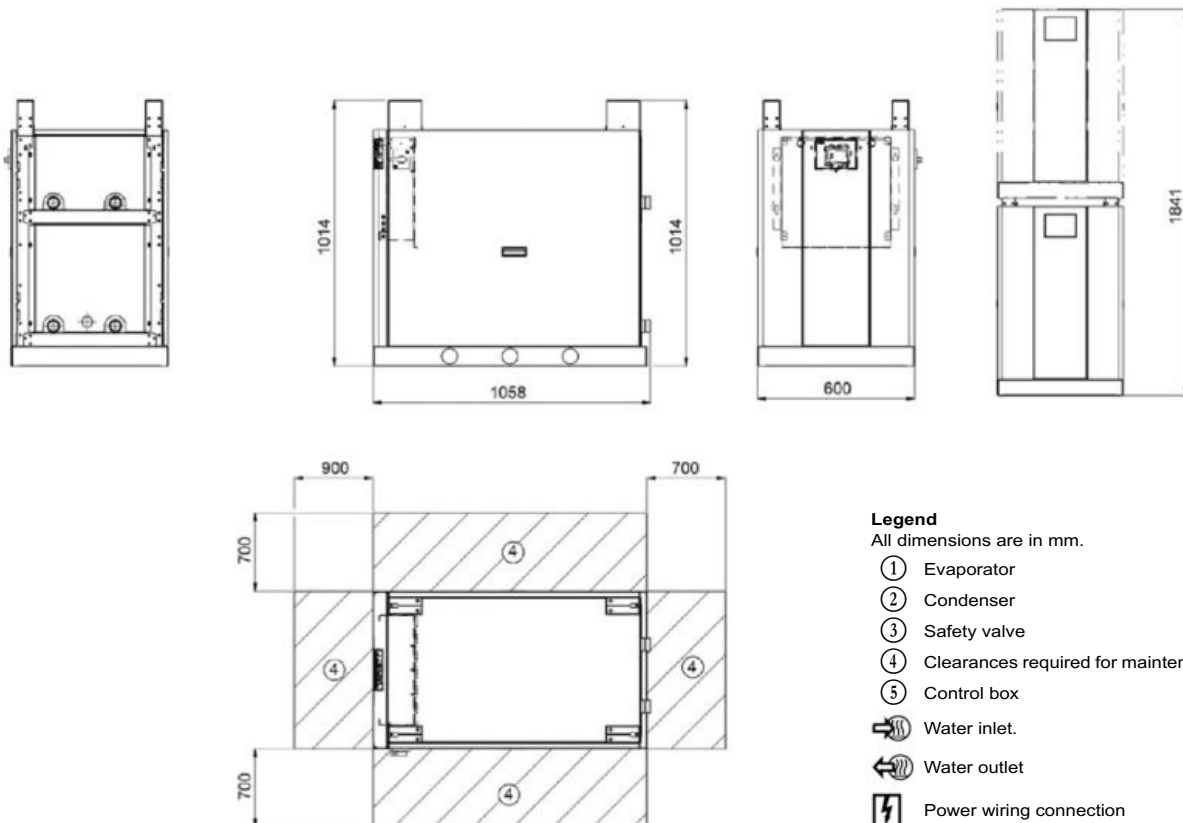

**Legend**

All dimensions are in mm.

- ① Evaporator
- ② Condenser
- ③ Safety valve
- ④ Clearances required for maintenance (see note)
- ⑤ Control box
- Water inlet.
- Water outlet
- Power wiring connection

**NOTE:** Non-contractual drawings. Refer to the certified dimensional drawings available on request, when designing an installation.



## DIMENSIONS/CLEARANCES

### 30WG 050-090 - unit with top connections (option 274)

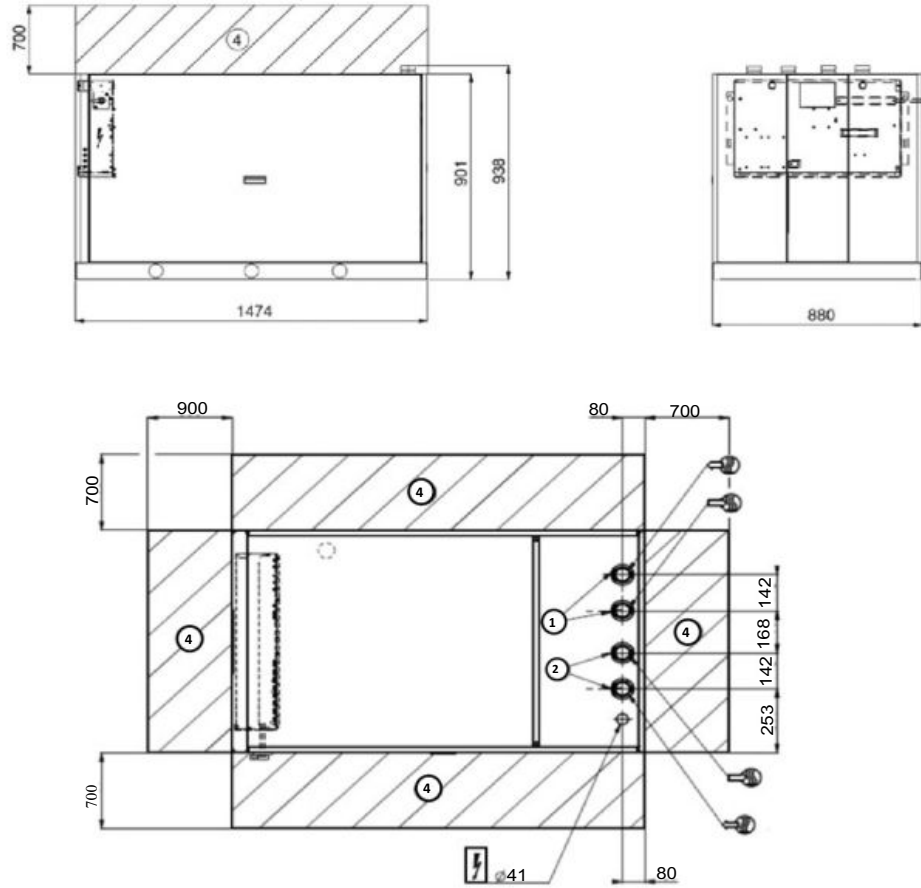

### 30WG 050-090 - unit with evaporator hydraulic module (option 116)

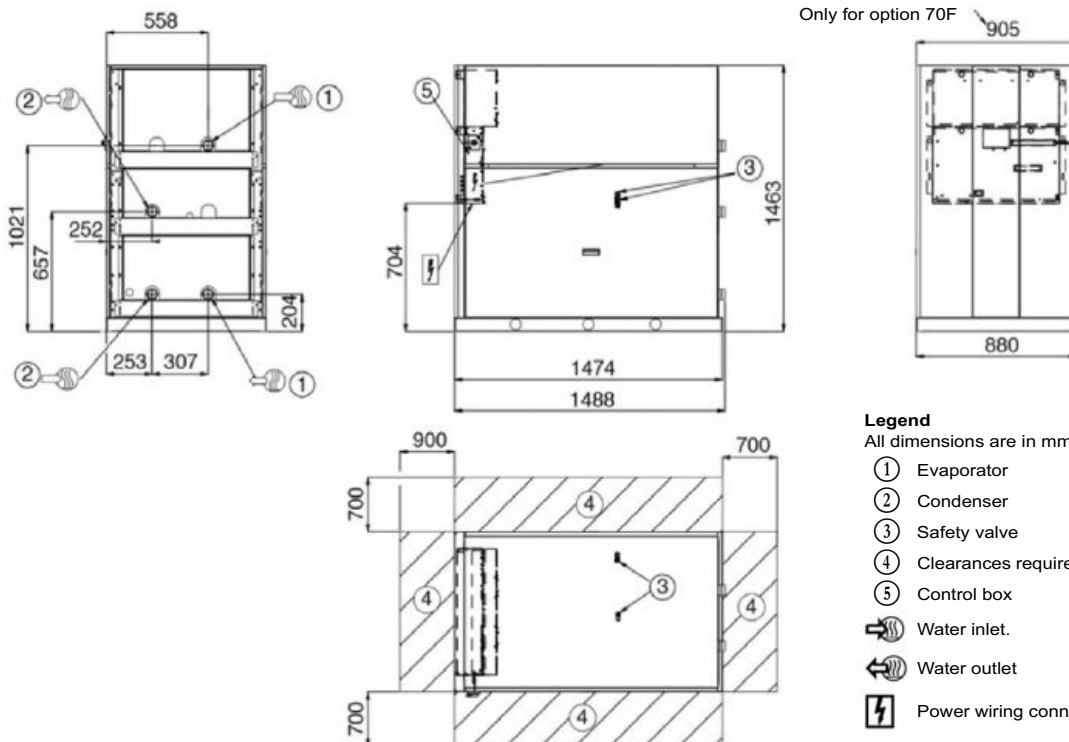

**NOTE:** Non-contractual drawings. Refer to the certified dimensional drawings available on request, when designing an installation.

## DIMENSIONS/CLEARANCES

### 30WG 050-090 - unit with condenser hydraulic module (option 270)

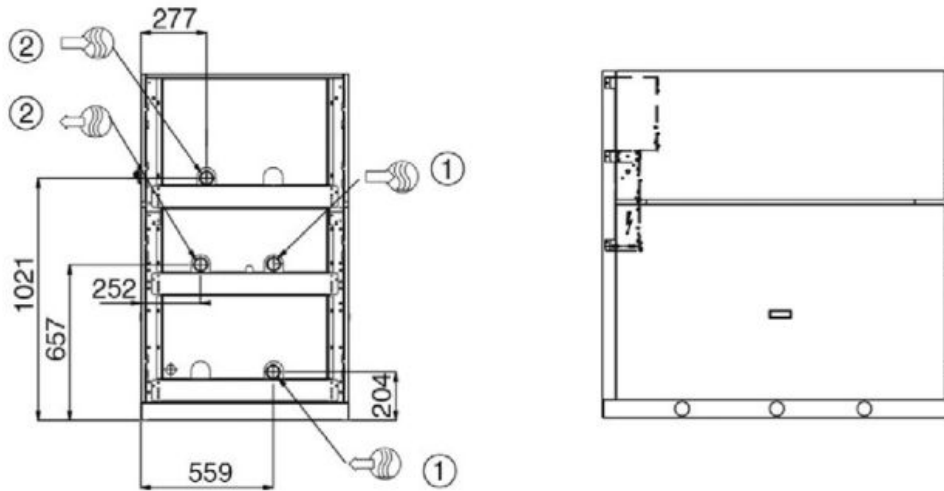

### 30WG 050-090 - unit with evaporator/condenser hydraulic modules (options 116 + 270)

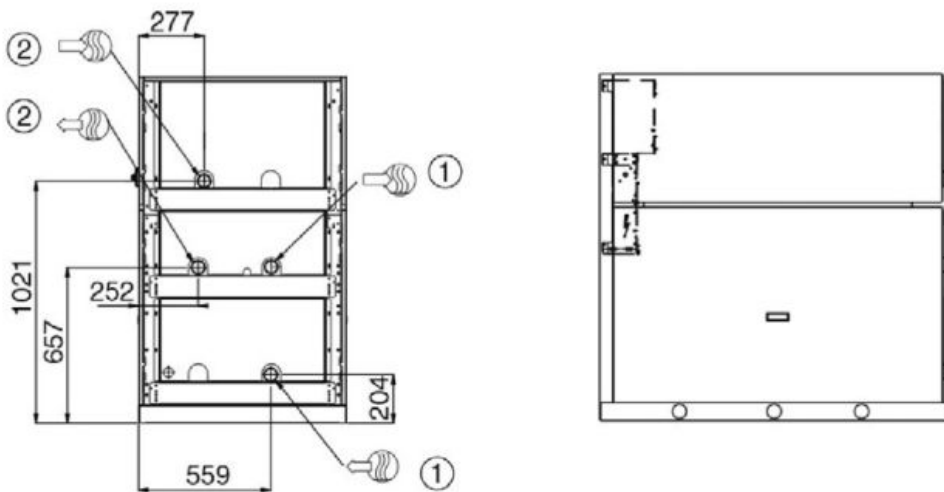

#### Legend

All dimensions are in mm.

- ① Evaporator
- ② Condenser
- ③ Safety valve
- ④ Clearances required for maintenance (see note)
- ⑤ Control box
- Water inlet.
- Water outlet
- Power wiring connection

**NOTE:** Non-contractual drawings. Refer to the certified dimensional drawings available on request, when designing an installation.

## DIMENSIONS/CLEARANCES

**30WG 050-090 - unit with hydraulic module and top connections (options 116 + 274 or 270 + 274 or 116 + 270 + 274)**

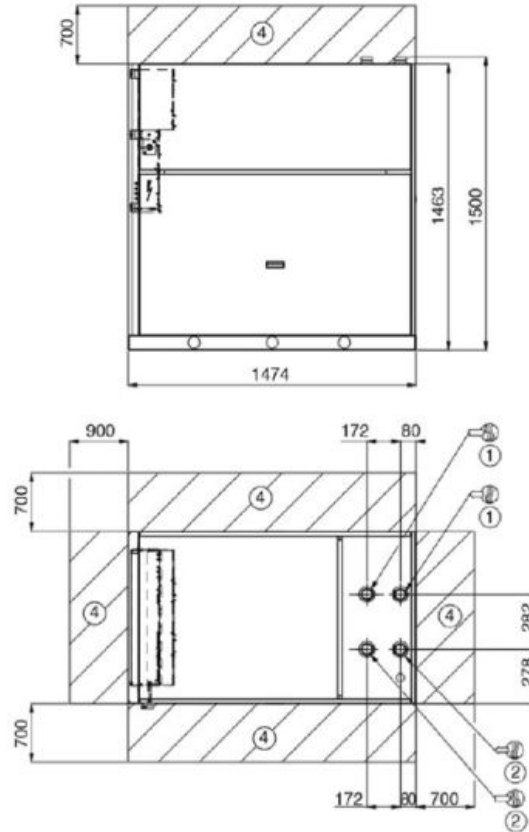

**30WG 050-090 - stackable unit (option 273)**

**NOTE:** The water and electrical connections are identical to those of the standard unit.

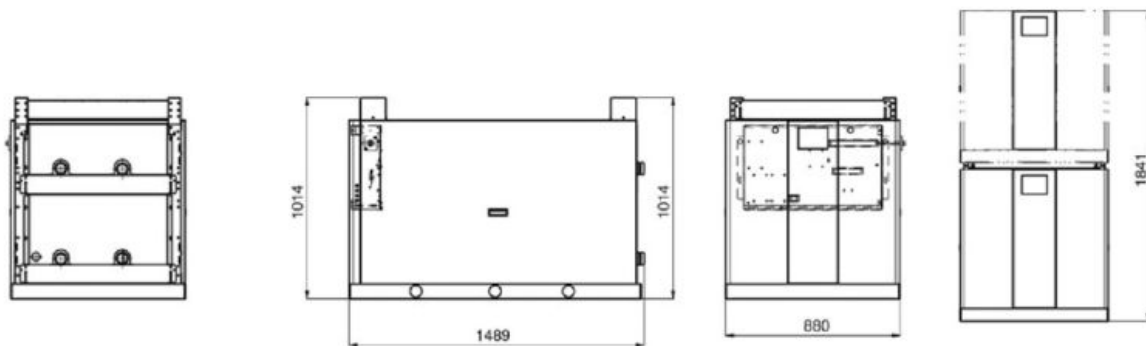

**Legend**

All dimensions are in mm.

- ① Evaporator
- ② Condenser
- ③ Safety valve
- ④ Clearances required for maintenance (see note)
- ⑤ Control box
- Water inlet.
- Water outlet
- Power wiring connection

**NOTE:** Non-contractual drawings. Refer to the certified dimensional drawings available on request, when designing an installation.

## DIMENSIONS/CLEARANCES

### 30WGA 110-140 - Standard unit

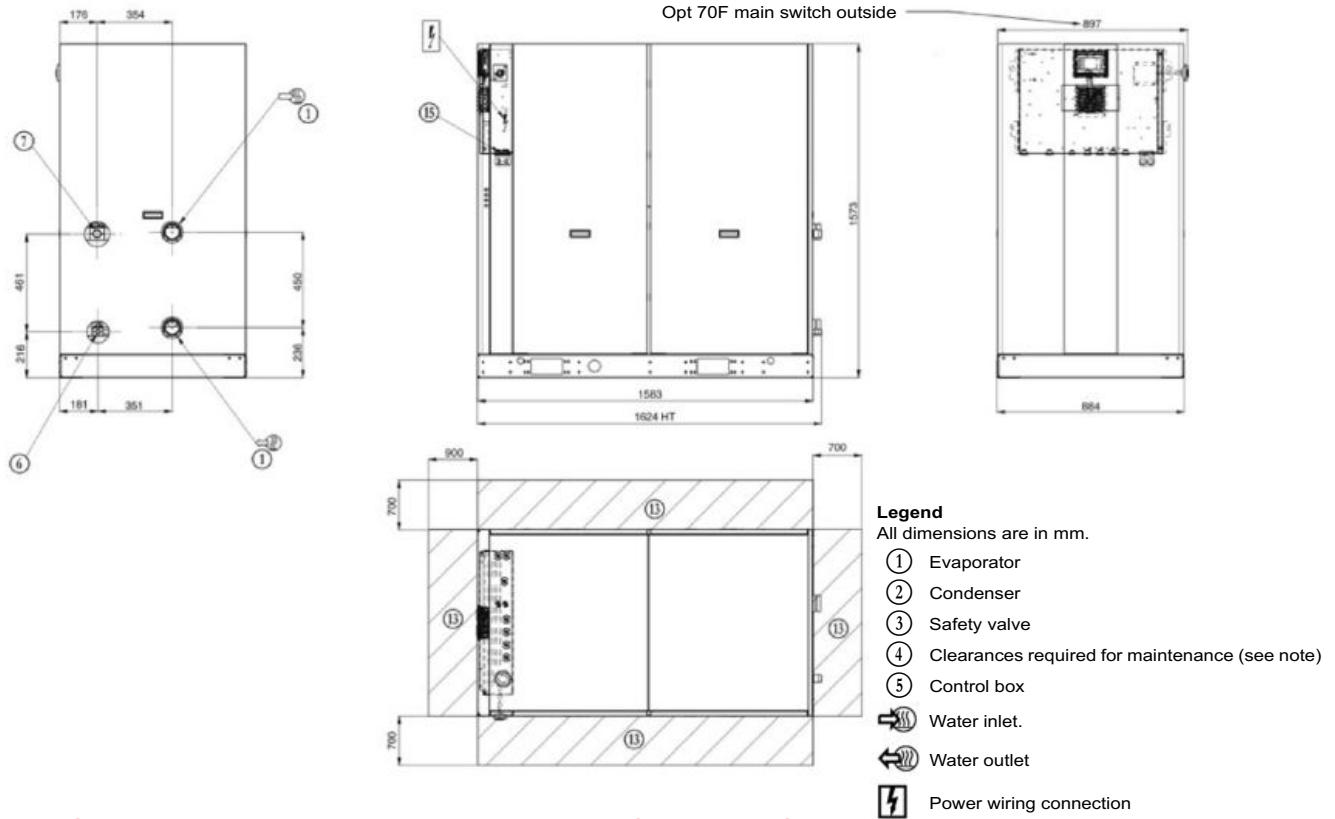

### 30WGA 110-140 - Unit with hydraulic module (option 116)

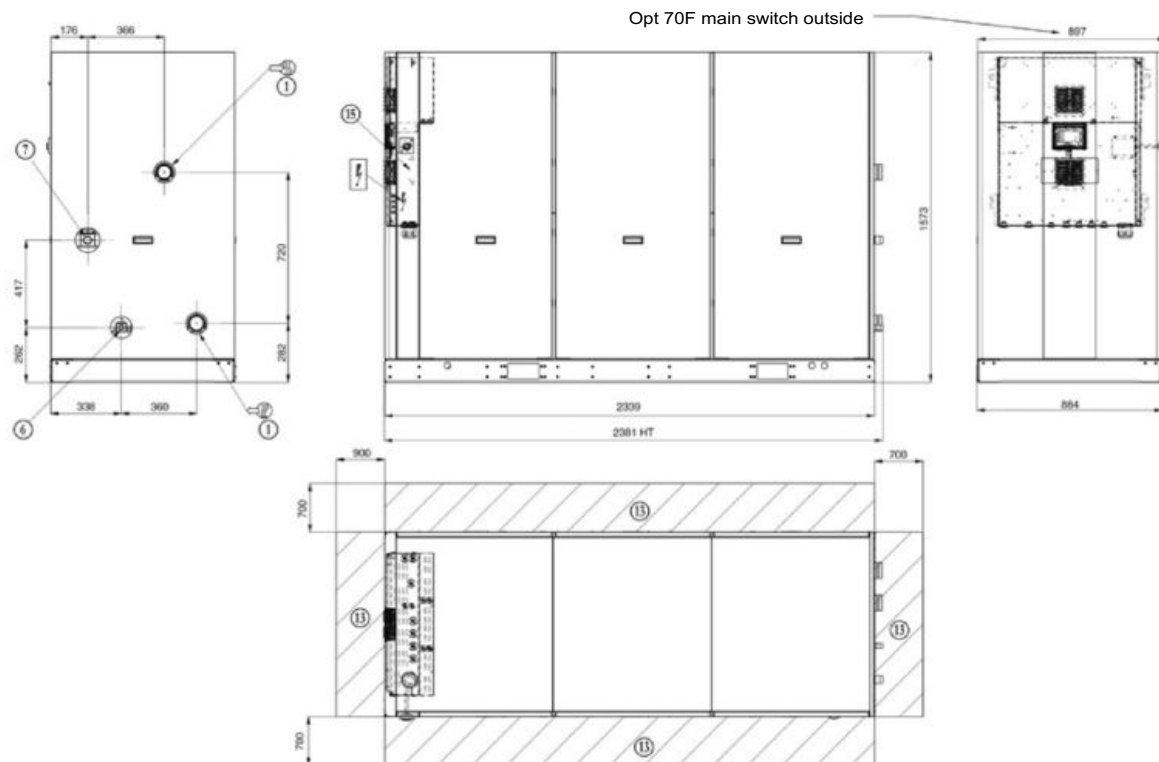

**NOTE:** Non-contractual drawings. Refer to the certified dimensional drawings available on request, when designing an installation.

## DIMENSIONS/CLEARANCES

### 30WGA 150-190 - Standard unit

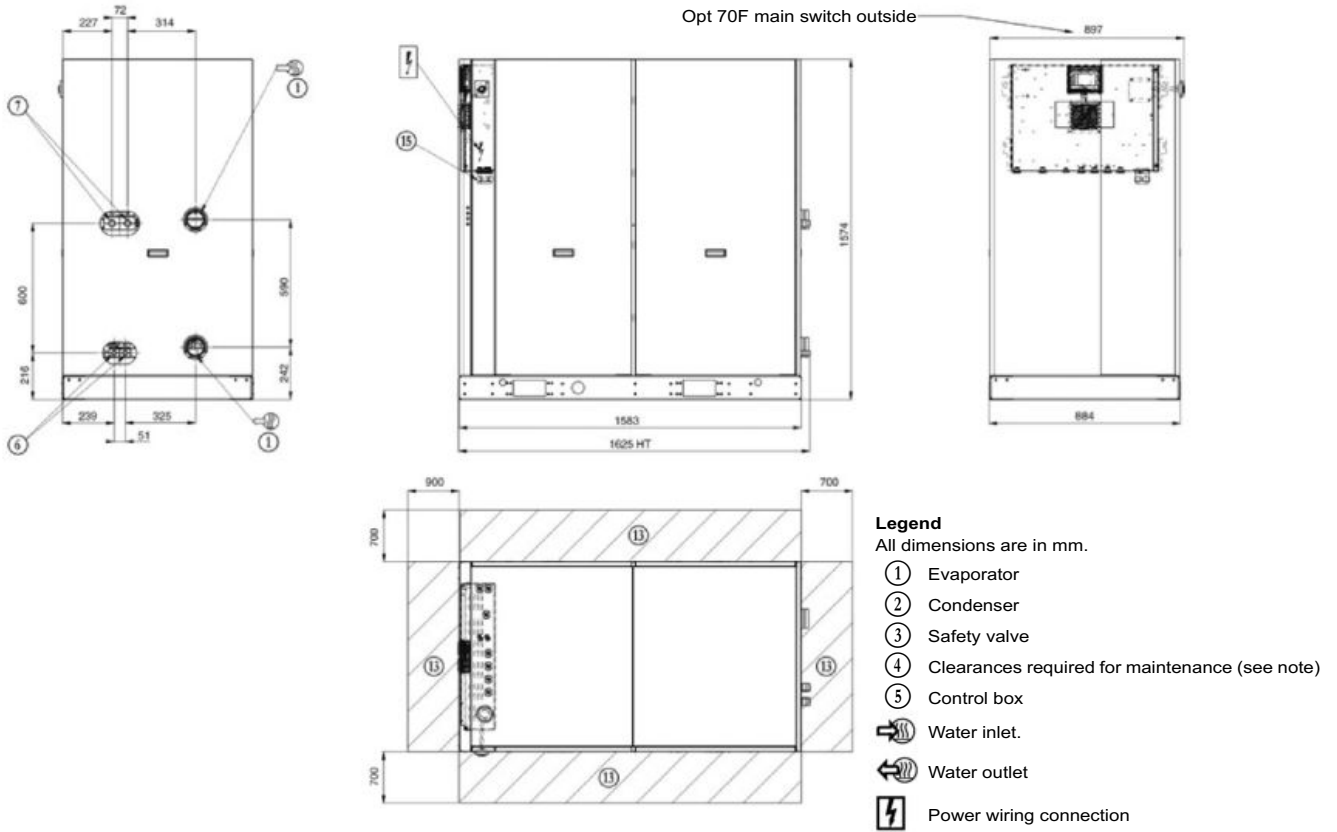

### 30WGA 150-190 - Unit with hydraulic module (option 116)

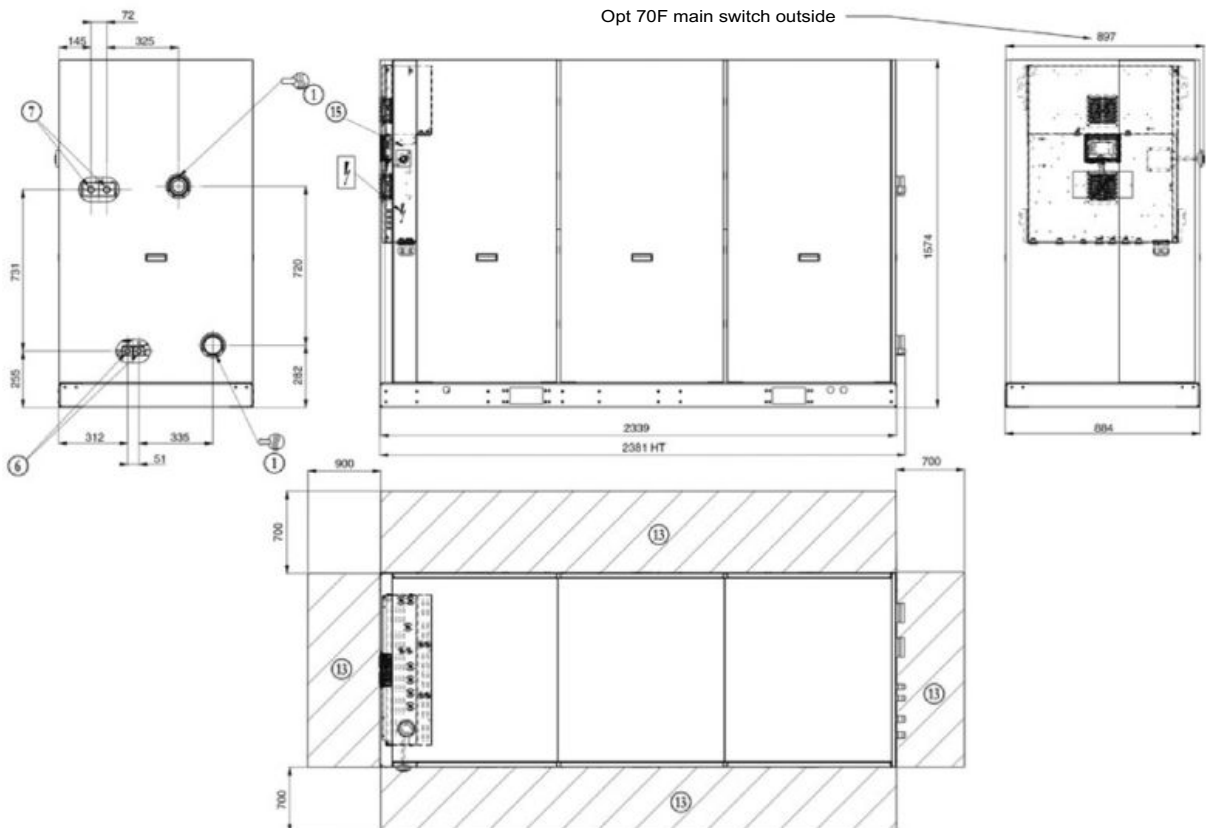

**NOTE:** Non-contractual drawings. Refer to the certified dimensional drawings available on request, when designing an installation.



## DIMENSIONS/CLEARANCES

### 30WG 110-140 - unit with hydraulic module (option 116-270)

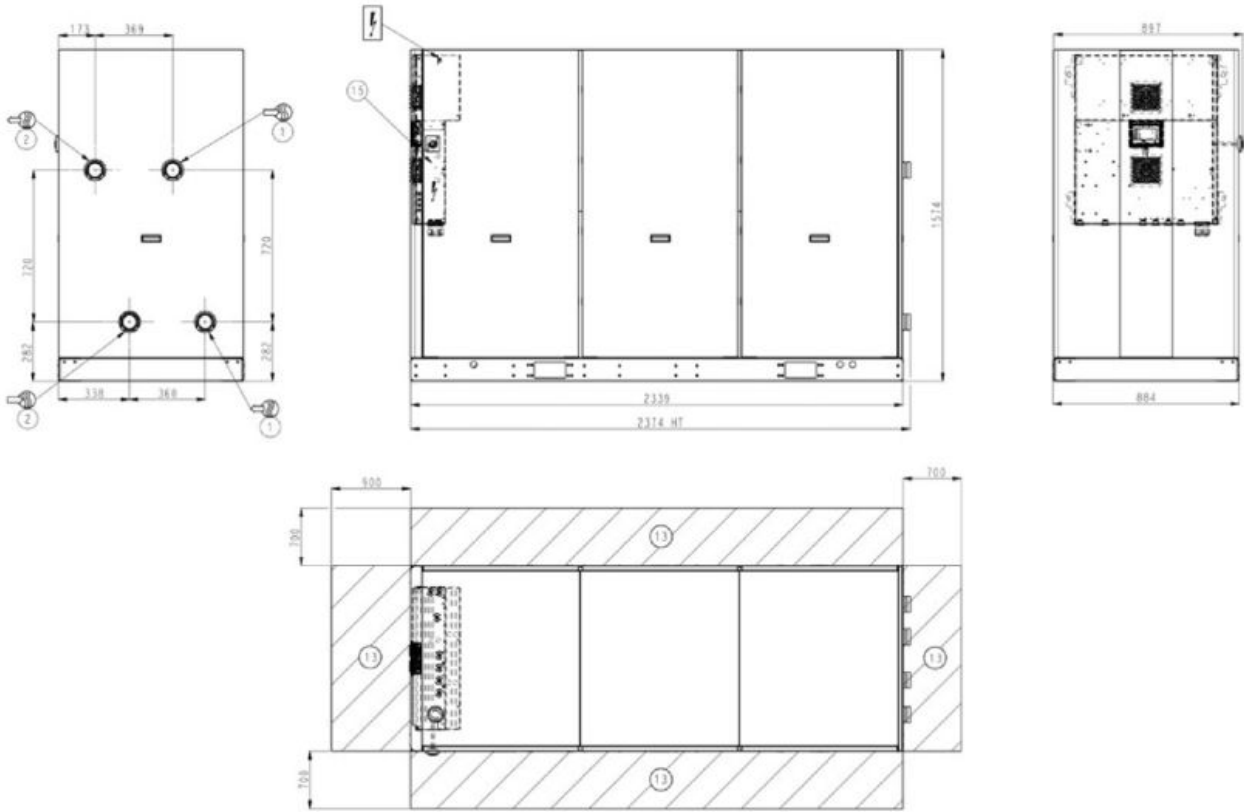

### 30WG 110-140 - unit with hydraulic module and top connections (option 116-270 and 274)

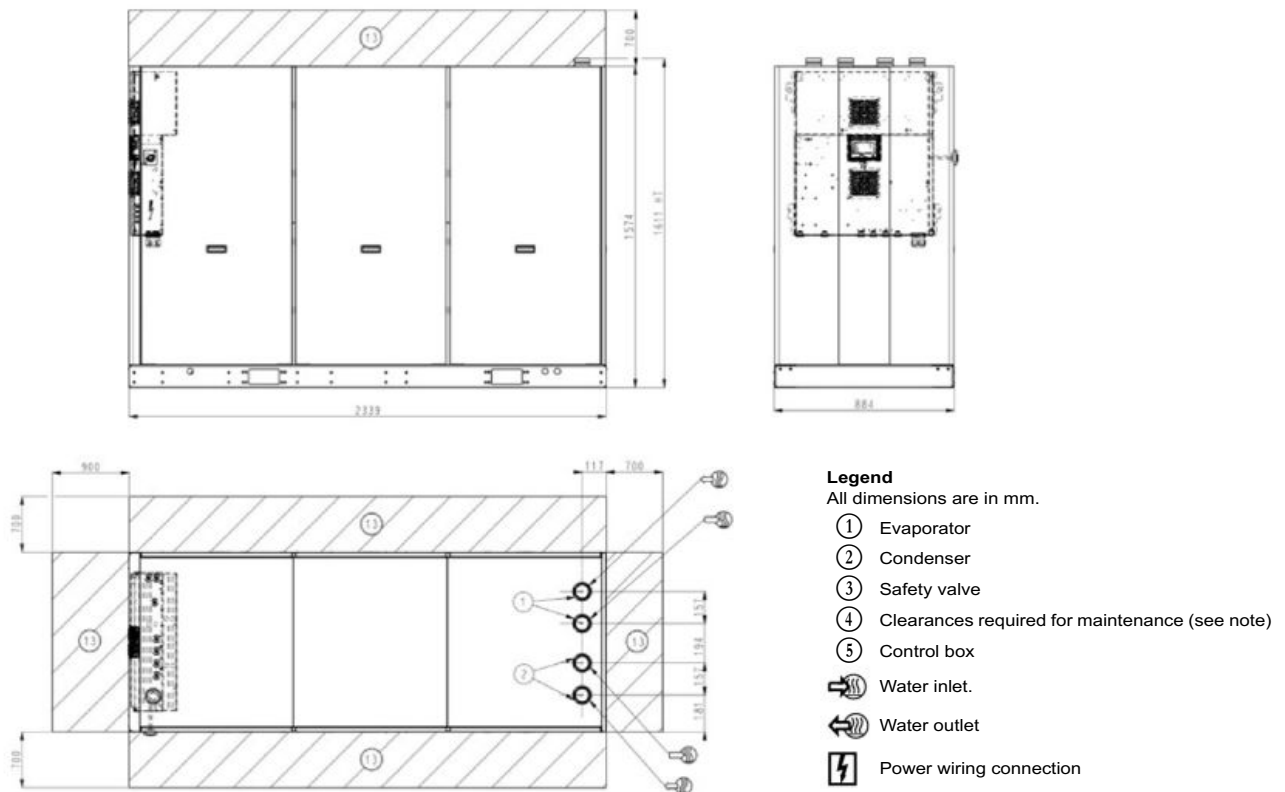

**NOTE:** Non-contractual drawings. Refer to the certified dimensional drawings available on request, when designing an installation.

## DIMENSIONS/CLEARANCES

### 30WG 150-190 - unit with hydraulic module (option 116-270)

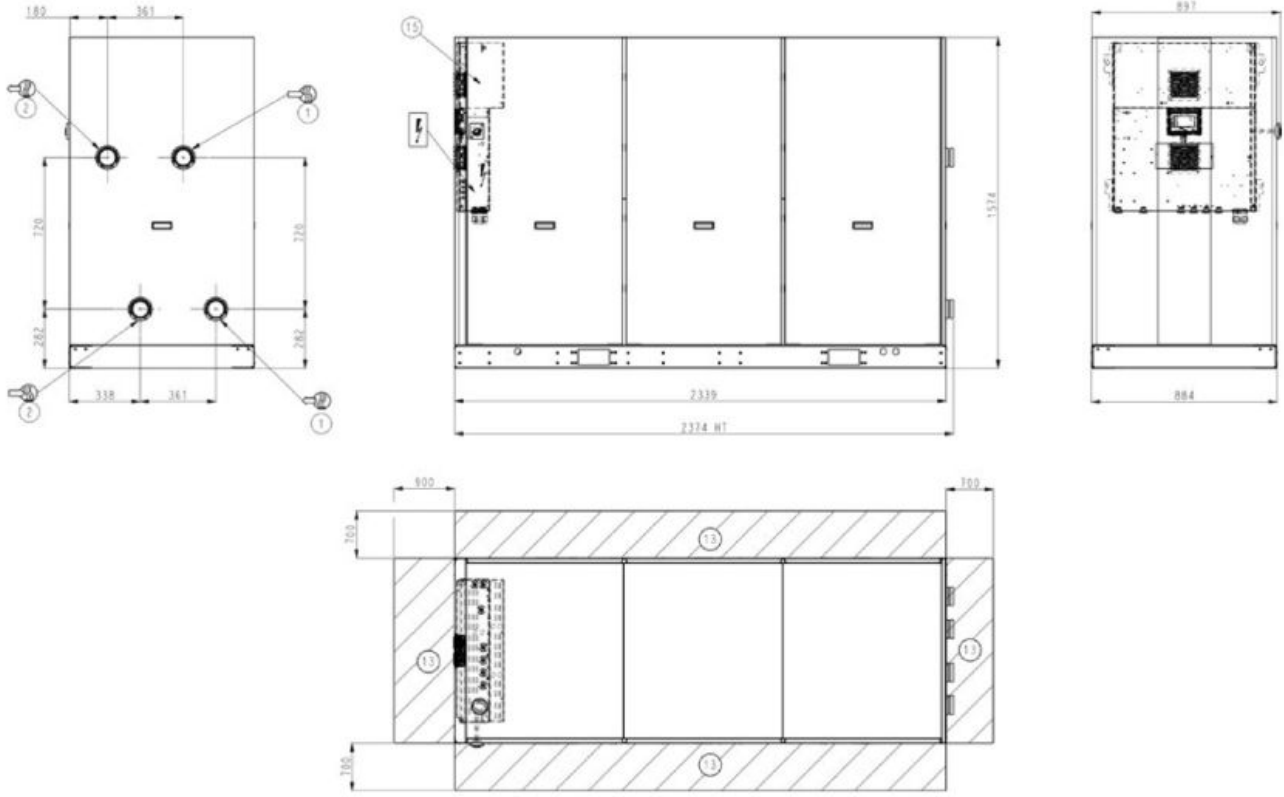

### 30WG 150-190 - unit with hydraulic module and top connections (option 116-270 and 274)

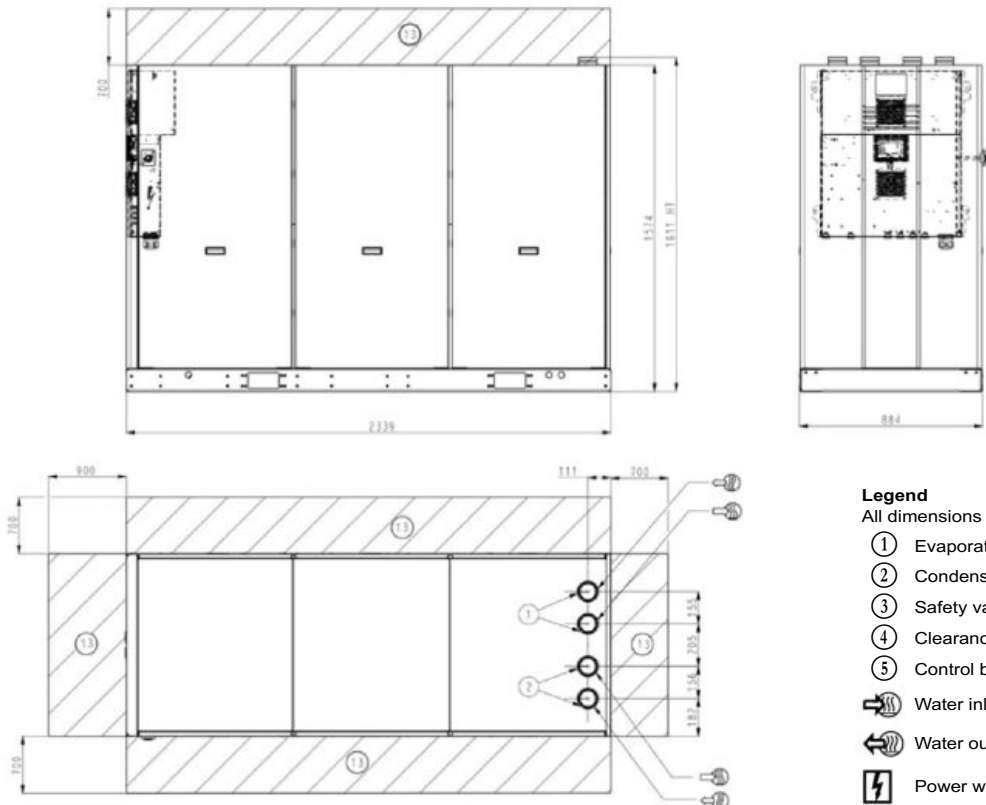

**Legend**

All dimensions are in mm.

- ① Evaporator
- ② Condenser
- ③ Safety valve
- ④ Clearances required for maintenance (see note)
- ⑤ Control box
- Water inlet.
- Water outlet
- Power wiring connection

**NOTE:** Non-contractual drawings. Refer to the certified dimensional drawings available on request, when designing an installation.

## DIMENSIONS/CLEARANCES

### 30WGA 020-045 - standard unit

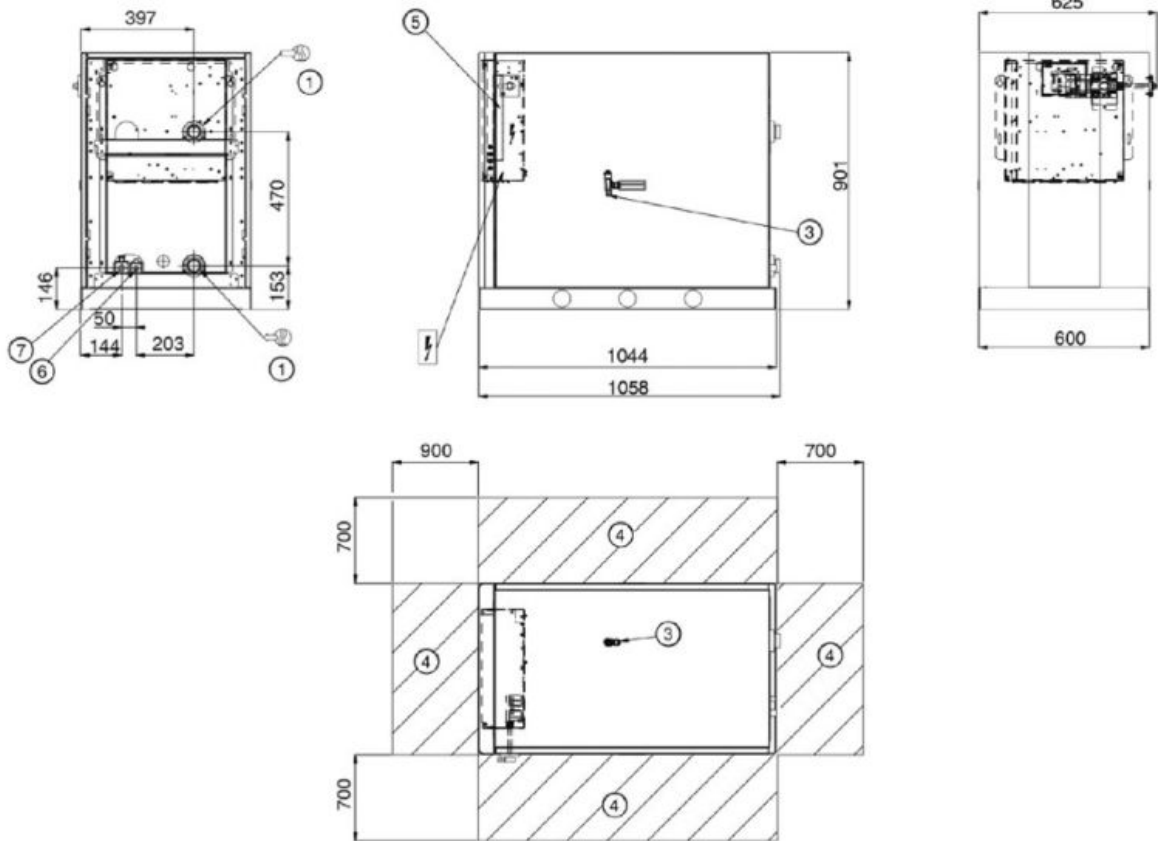

### 30WGA 020-045 - unit with evaporator hydraulic module (option 116)

For option 70F only

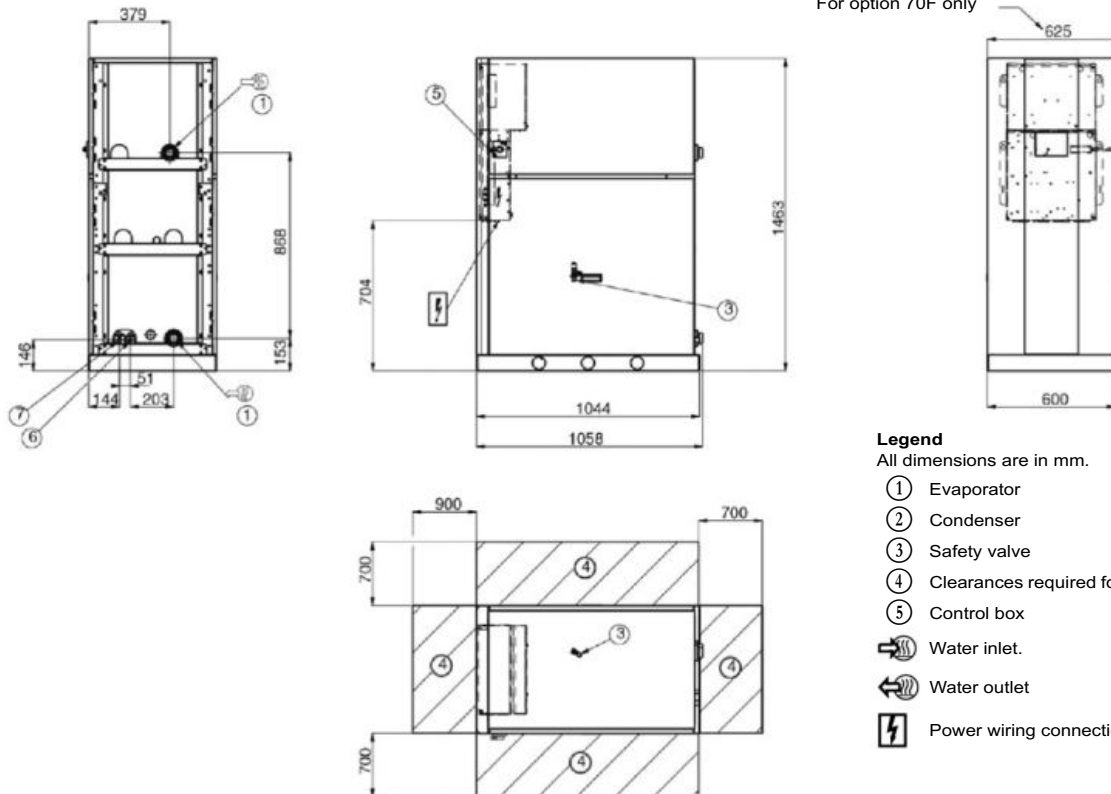

#### Legend

All dimensions are in mm.

- ① Evaporator
- ② Condenser
- ③ Safety valve
- ④ Clearances required for maintenance (see note)
- ⑤ Control box
- Water inlet.
- Water outlet
- Power wiring connection

**NOTE:** Non-contractual drawings. Refer to the certified dimensional drawings available on request, when designing an installation.

## DIMENSIONS/CLEARANCES

### 30WGA 020-045 - stackable unit (option 273)

**NOTE:** The water and electrical connections are identical to those of the standard unit.

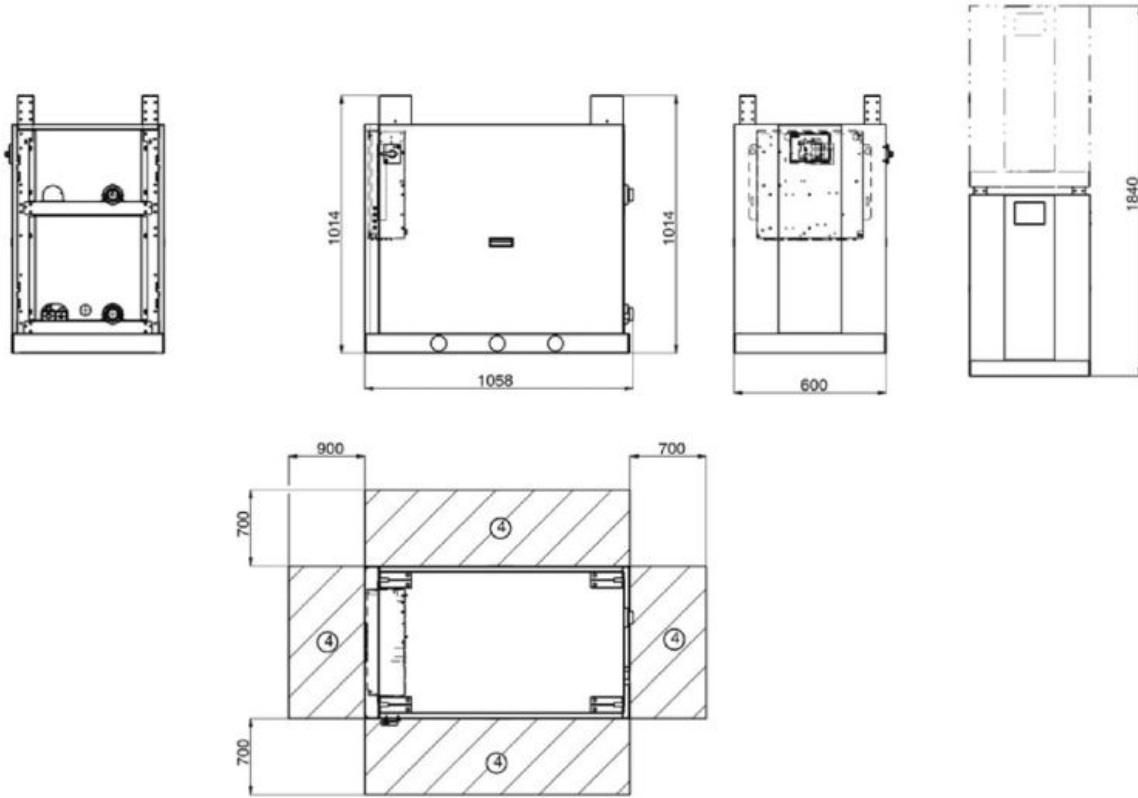

### 30WGA 050-090 - standard unit

For option 70F only

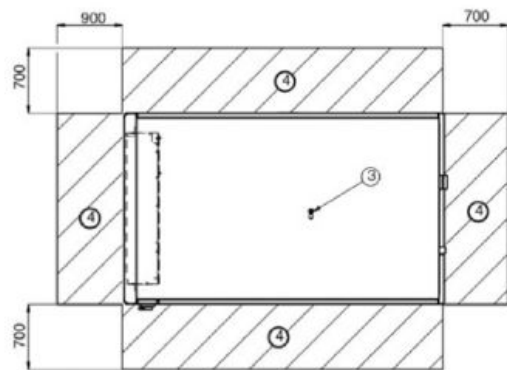
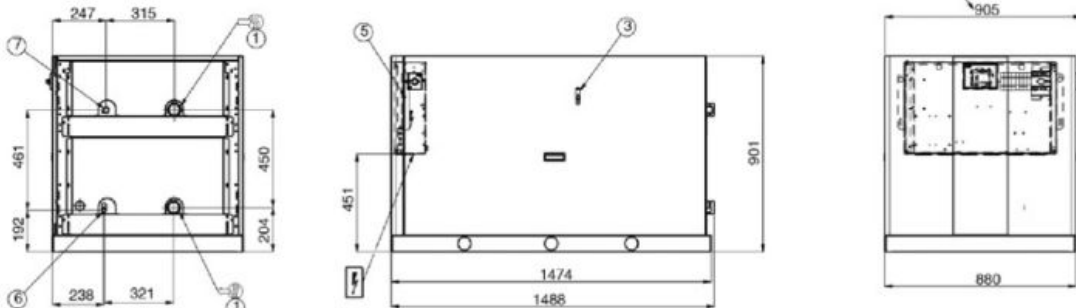

**Legend**

All dimensions are in mm.

- ① Evaporator
- ② Condenser
- ③ Safety valve
- ④ Clearances required for maintenance (see note)
- ⑤ Control box
- Water inlet.
- Water outlet
- Power wiring connection

**NOTE:** Non-contractual drawings. Refer to the certified dimensional drawings available on request, when designing an installation.

## DIMENSIONS/CLEARANCES

### 30WGA 050-090 - unit with evaporator hydraulic module (option 116)

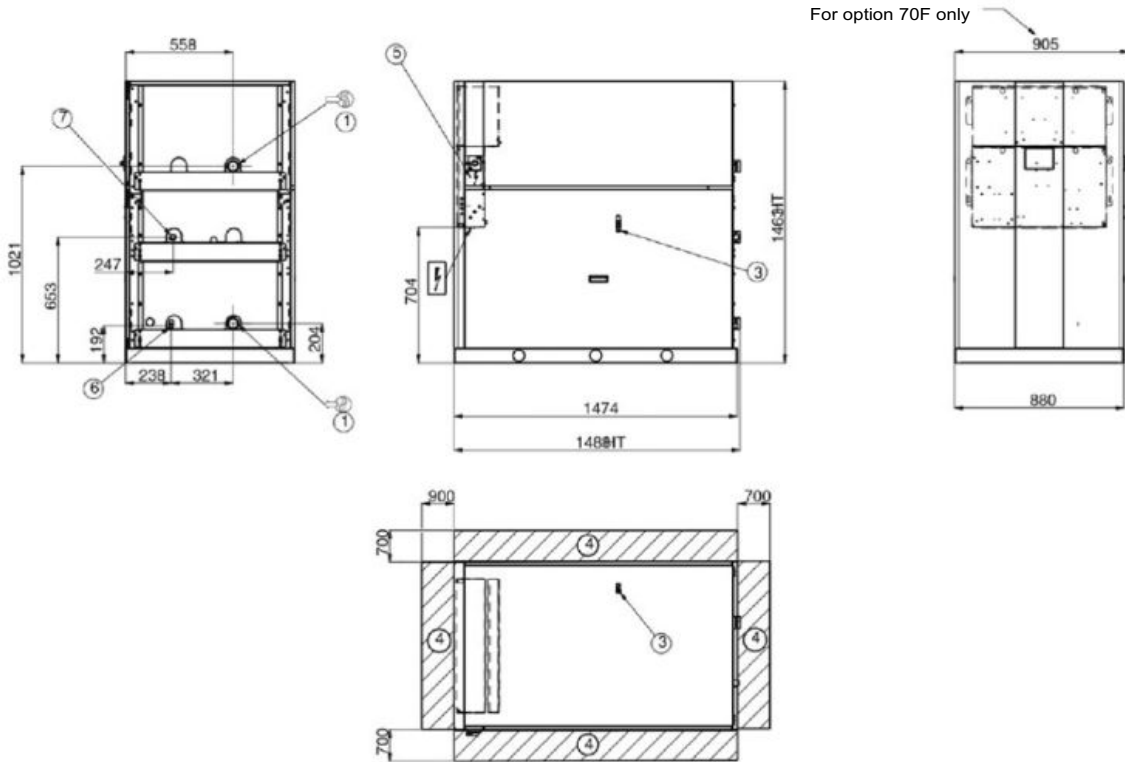

### 30WGA 050-090 - stackable unit (option 273)

**NOTE:** The water and electrical connections are identical to those of the standard unit.

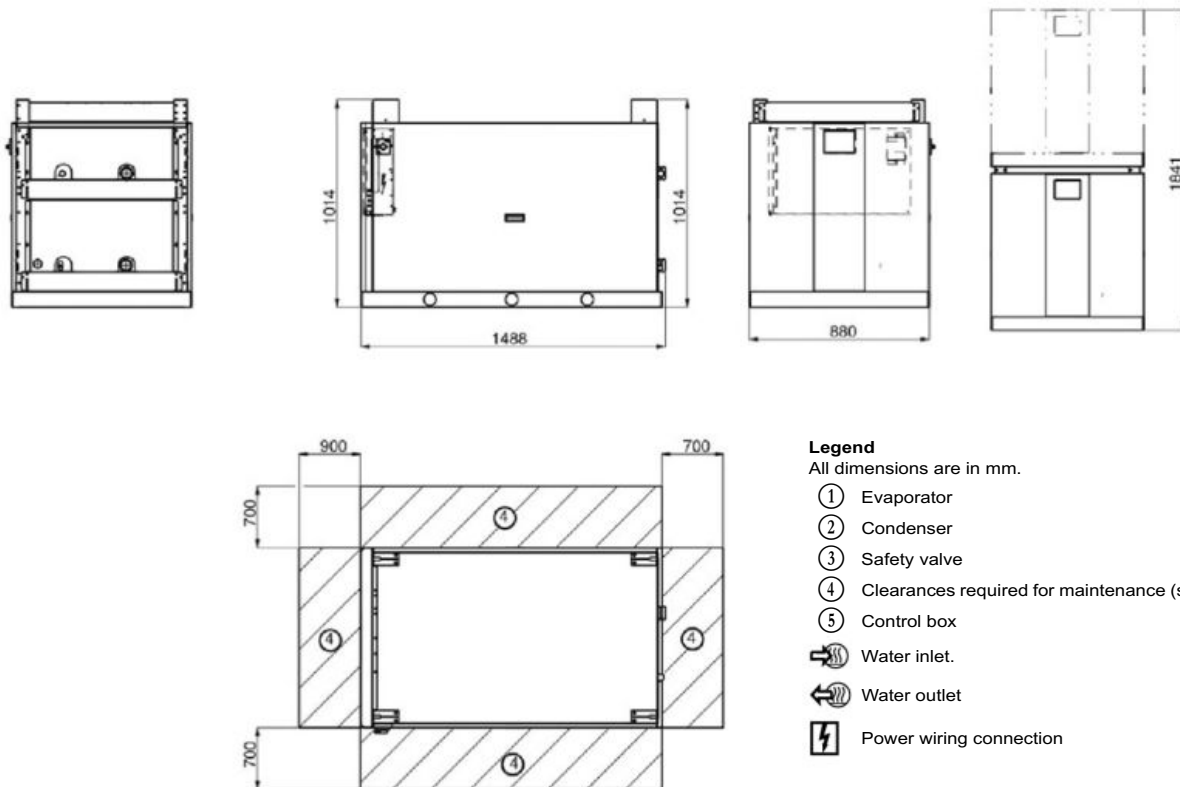

**NOTE:** Non-contractual drawings. Refer to the certified dimensional drawings available on request, when designing an installation.



## DIMENSIONS/CLEARANCES

### 30WGA 110-140 - Standard unit

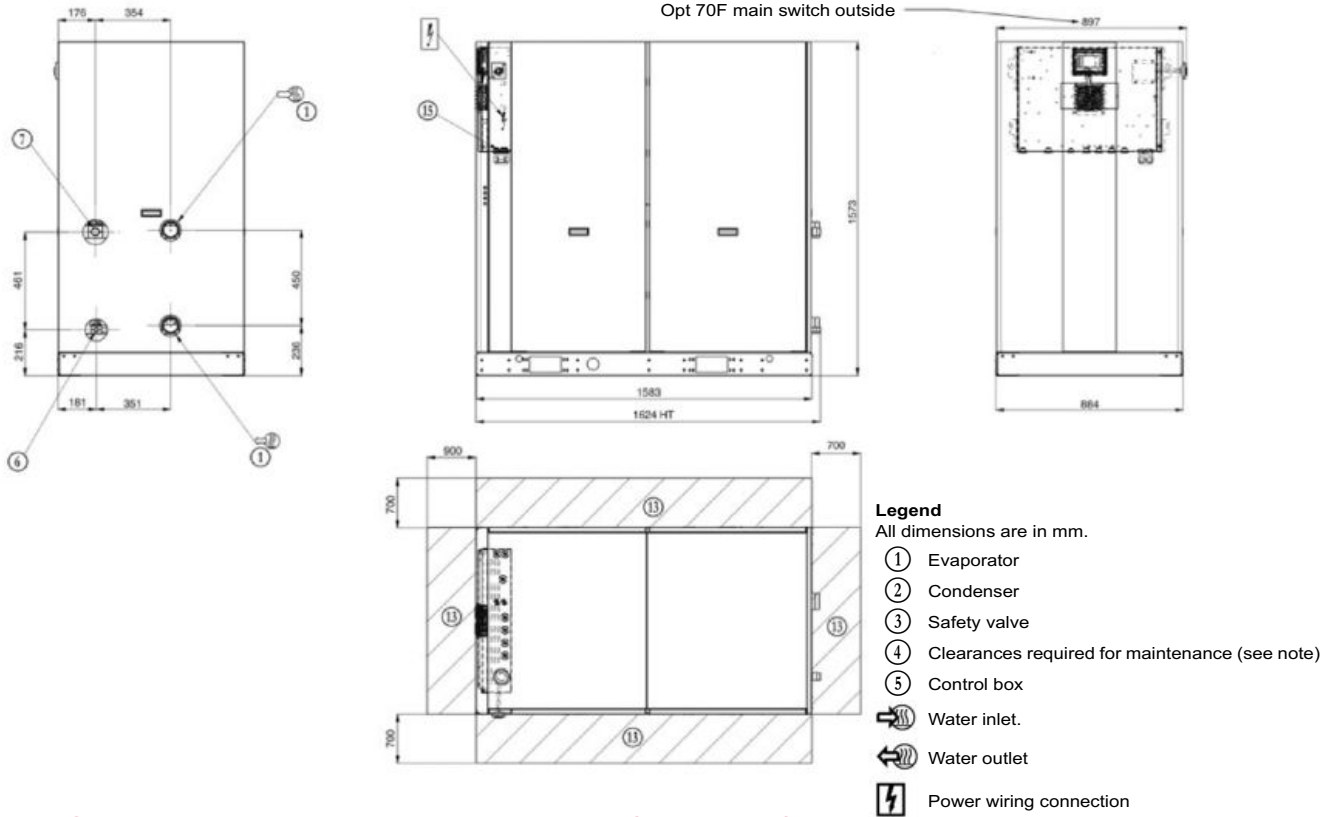

### 30WGA 110-140 - Unit with hydraulic module (option 116)

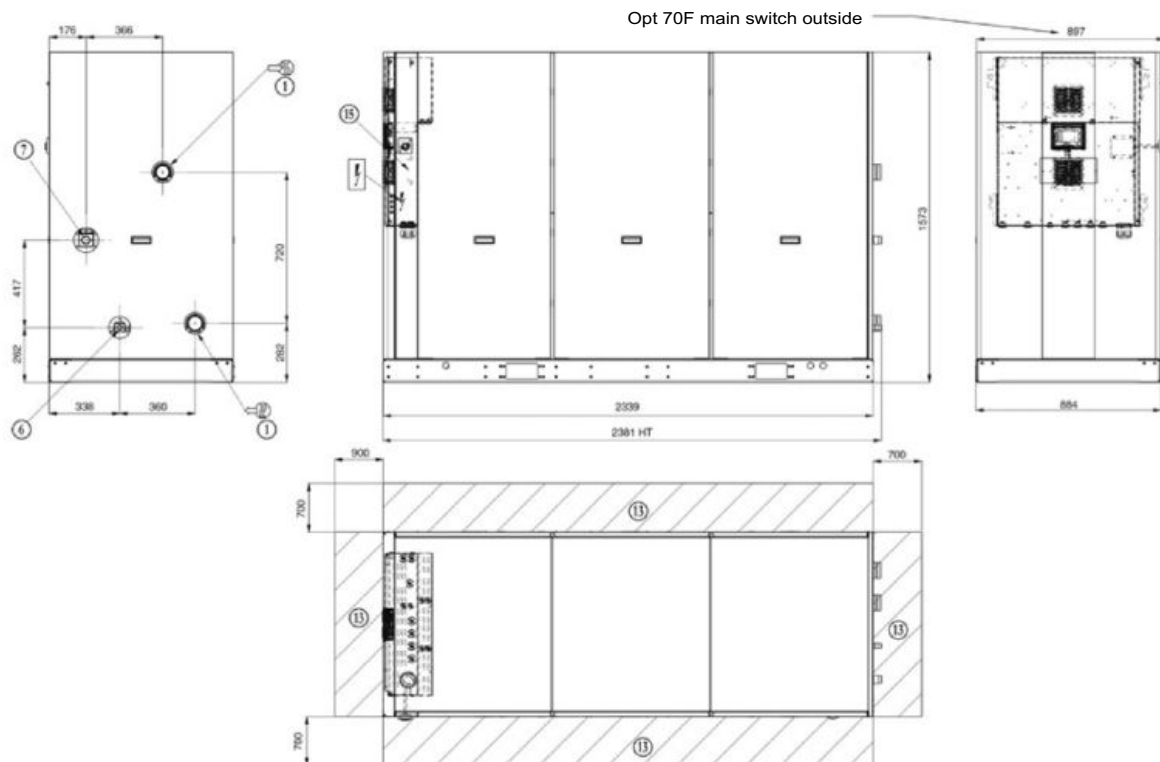

**NOTE:** Non-contractual drawings. Refer to the certified dimensional drawings available on request, when designing an installation.

## DIMENSIONS/CLEARANCES

### 30WGA 150-190 - Standard unit

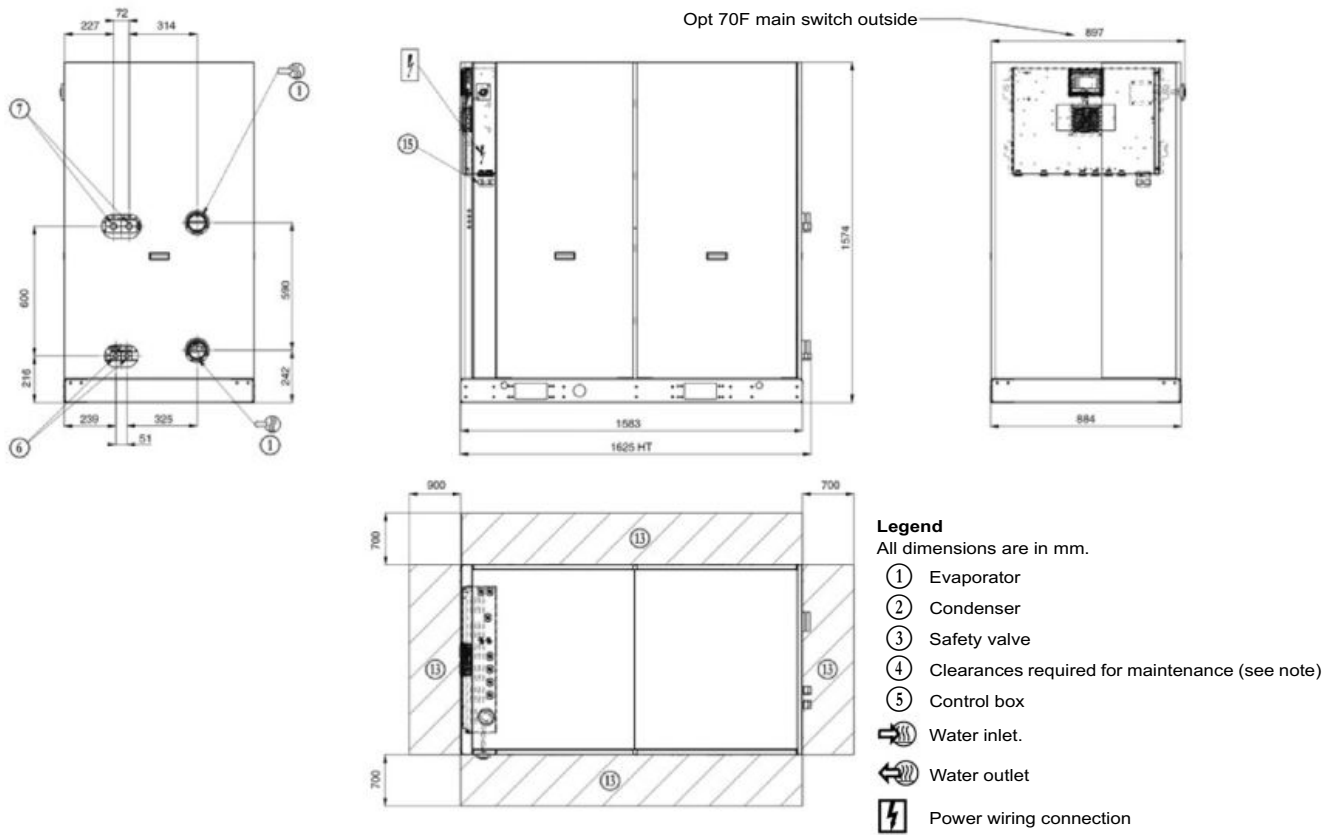

### 30WGA 150-190 - Unit with hydraulic module (option 116)

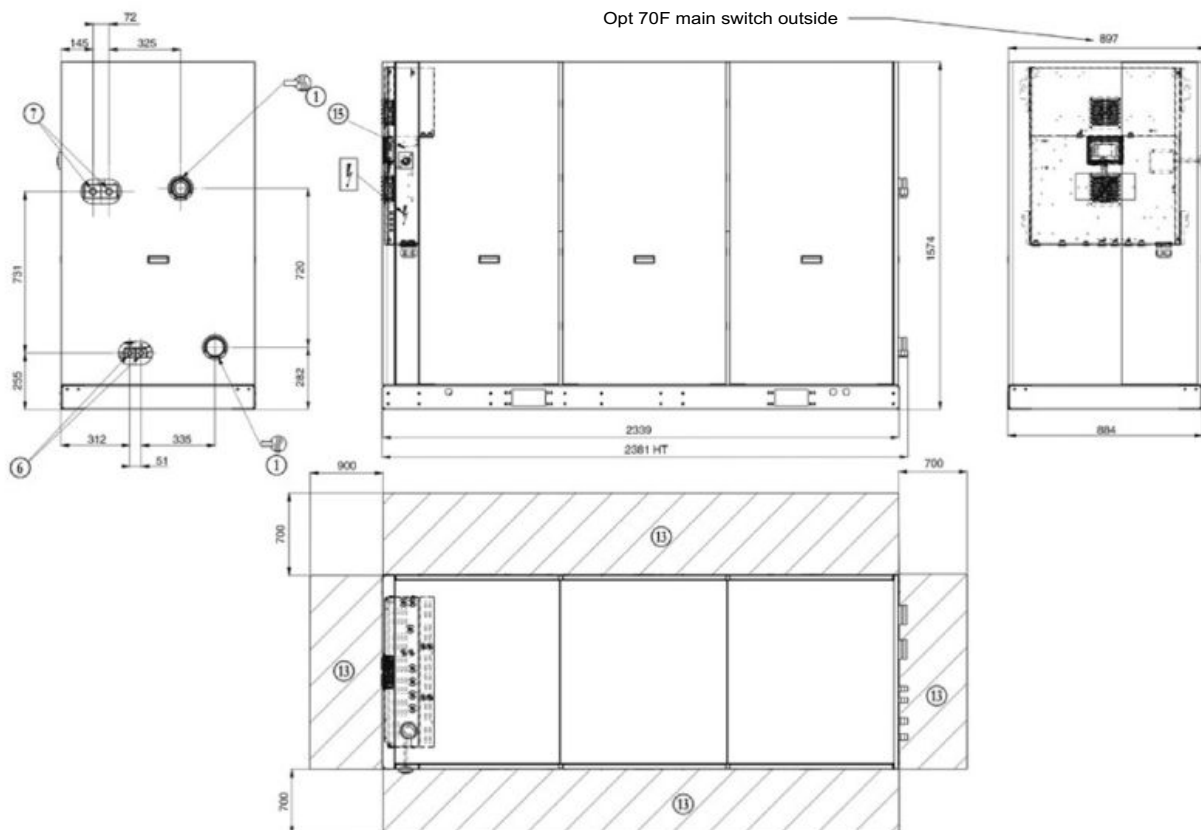

**NOTE:** Non-contractual drawings. Refer to the certified dimensional drawings available on request, when designing an installation.





## HEAT PUMPS AND LIQUID COOLERS WITH WATER COOLED CONDENSER



- Cooling and heating application
- High energy efficiency
- Compact design
- Low sound level
- Broad field of application

## 30WI 700 V - 2400 V

Heating capacity: 230-800 kW  
Cooling capacity: 200-700 kW

The new generation of AQUASNAP 30WI water cooled heat pumps and water chillers offers an optimal solution for all heating process or cooling applications.

These units are designed to be installed in machine rooms that are protected against freezing temperatures and inclement weather.

The new range has been optimised to use ozone-friendly HFC R410A refrigerant. The use of this refrigerant guarantees compliance with the most demanding requirements for environmental protection and increased seasonal energy efficiency.



CARRIER participates in the ECP programme for LCP-HP  
Check ongoing validity of certificate:  
[www.eurovent-certification.com](http://www.eurovent-certification.com)

## RANGE

---

### AQUASNAP 30WI

Cooling-only or heating-only models with water-cooled condenser.

Acoustic configuration:

- a - STANDARD version
- b - LOW NOISE version. Compressor casing
- c - VERY LOW NOISE version. Casing with compressor sound insulation

## DESCRIPTION

---

AQUASNAP series 30WI units are packaged machines supplied as standard with the following components:

- SCROLL hermetic compressors,
- Chilled water evaporator with brazed plates,
- Hot water condenser with brazed plates,
- Electrical power and remote control cabinet:
  - 400V-3ph-50Hz general electrical power supply (+10%/-10%) + earth,
  - Transformer fitted as standard on the machine for supplying the remote control circuit with 230V-1ph-50Hz,
- 30WI Control electronic control module.

The AQUASNAP 30WI range complies with the following European standards and directives:

- Machinery directive 2006/42/EC.
- Electromagnetic compatibility directive 2004/108/EC.
- EMC immunity and emissions EN 61800-3 'C3'
- Low voltage directive 2006/95/EC.
- RoHS 2011/65/EU
- Pressure equipment directive (PED) 97/23/EC
- Machinery directive EN 60-204 -1



## DESCRIPTION OF THE MAIN COMPONENTS

### ■ Compressors

- Hermetic SCROLL type.
- Built-in electric motor cooled by intake gases.
- Motor protected by internal winding thermostat.
- Placed on anti-vibration mounts.

### ■ Evaporator

- Brazed plate exchanger.
- Stainless steel plates (AISI 316).
- Plate patterns optimised for high efficiency.
- Armaflex thermal insulation.

### ■ Condenser

- Brazed plate exchanger.
- Stainless steel plates (AISI 316).
- Plate patterns optimised for high efficiency.

### ■ Refrigerating accessories

- Dehumidifier filters with rechargeable cartridges.
- Hygroscopic sight glasses.
- Solenoid valves on refrigerant lines (700 V to 1200 V models).
- Electronic expansion valves.

### ■ Control and safety instruments

- High and low pressure sensors.
- High pressure safety valves.
- Water temperature control sensors.
- Evaporator frost protection sensor.
- Factory-assembled evaporator water flow controller.

### ■ Electrical box

- IP 23.
- 400V-3Ph-50 Hz power supply + Earth (+10%/-10%).
- Main safety switch with handle on front.
- Control circuit transformer.
- Circuit breaker for compressor motor.
- Compressor motor switches.
- 30WI Control microprocessor-controlled electronic control module.
- Wire numbering.
- Marking of the main electrical components.
- RAL 7035.

### ■ 30WI Control electronic control module.

The electronic control module performs the following main functions:

- Regulation of the chilled or hot water temperature
- Regulation of the water temperature based on the outdoor temperature (water law).
- Regulation for low temperature energy storage.
- Second setpoint management.
- Complete management of compressors with start-up sequence, metering and runtime balancing.
- Self-adjusting and proactive functions with adjustment of parameters on drift control.
- In-series staged capacity-reduction system on compressors based on cooling and heating demands.
- Management of compressor short cycle protection.
- Management of the machine operation limit according to outdoor temperature.
- Operating and fault status diagnostics.
- Management of a fault memory allowing a log of the last 20 incidents to be accessed, with operating readings taken when the fault occurs.
- Master/slave management of the two machines in parallel with runtime balancing and automatic changeover if a fault occurs on one machine.
- Machine time schedule.
- Display and access to the operating parameters via a multilingual LCD screen with 4 lines of 24 characters.

### ■ Remote management

30WI Control is equipped as standard with an RS485 serial port offering a range of remote management, monitoring and diagnostic options via the communication bus.

Several contacts are available as standard, enabling the AQUASNAP 30WI to be controlled remotely by wired link:

- Automatic operation control: when this contact is open, the machine stops.
- Setpoint 1/setpoint 2 selector: when this contact is closed, a second cooling setpoint is activated (energy storage mode, for example).
- Heating/cooling mode selector: this input switches from one operating mode to another. Contact closed = heating mode.

Contact open = cooling mode.

- Setpoint adjustable via 4-20 mA signal: this input is used to adjust the setpoint in heating or cooling mode.
- Compressor load shedding: closing the contact(s) concerned allows the power or refrigerating consumption of the machine to be limited by stopping one or more compressors.
- Water pump 1 and 2 control: these outputs control the switches for one or two water pumps.
- Fault reporting: this contact indicates the presence of a major fault which has caused one or both refrigerating circuits to stop.

### ■ Capacity control

In-series staged power control system on the compressors:

- 4 stages for 700 V to 1600 V models.
- 6 stages for 1800 V and 2400 V models.
- 8 stages for 2100 V models.

### ■ Casing

Casing made from RAL 7035 painted panels.

## OPTIONS

Options	No.	Description	Advantages	Use
Soft Starter	25	Electronic starter on each compressor	Reduced start-up current	0700-2400
Master/slave operation	58	Unit equipped with supplementary water outlet temperature sensor kit to be fieldinstalled allowing master/slave operation of two units connected in parallel	Optimised operation of two units connected in parrallele operation with operating time equalisation	0700-2400
Condenser insulation	86	Thermal condenser insulation	Minimizes thermal dispersions condenser side (key option for heat pump or heat recovery applications) and allows compliancy with special installation criteria (hot parts insulated)	0700-2400
Compressor suction valve	92	Valve installed on the compressor suction side to isolate it in the refrigerant circuit	Simplified service and maintenance	0700-2400
Lon gateway	148D	Two-directional communication board complying with Lon Talk protocol	Connects the unit by communication bus to a building management system	0700-2400
Bacnet over IP	149	Two-directional high-speed communication using BACnet protocol over Ethernet network (IP)	Easy and high-speed connection by ethernet line to a building management system. Allows access to multiple unit parameters	0700-2400
Dry contact board	156C	Feedback board on the potential-free contact for the main statuses and faults	Simple feedback of the diagnostics and unit state	0700-2400
Phase controller	159B	Phase controller on the power	Reinforced protection of the compressors by monitoring rotation, the absence and asymmetry of the phases, and the over- or under-voltage of the electricity network	0700-2400
Compliance with Russian regulations	199	EAC certification	Conformance with Russian regulations	0700-2400
Low noise level	257	Compressor sound enclosure	Reduced sound emissions	0700-2400
Very low sound level	258	Enhanced sound insulation of main noise sources (Material classified CD0S2 fire class according to Euroclass 13-501).	6 dB(A) quieter than standard . Refer to the physical data table for detailed values	0700-2400
Welded evaporator connection kit	266	Victaulic piping connections with welded joints	Easy installation	0700-2400
Welded condenser water connection kit	267	Victaulic piping connections with welded joints	Easy installation	0700-2400
Electric energy meter	294	MID certified electric energy meter (compliant with directive 2004/22/EC). Display of energy consumption, instantaneous (U, V, I) and cumulative (kWh), on the SmartVu™ interface	Permits the acquisition, (remote) monitoring and billing of energy used.	0700-2400
External temperature sensor	312	External temperature sensor control for using weather compensation	Allow to adjust set point using weather compensation and define autorisation operation mode to external temperature	0700-2400
Compliance with Morocco regulation	327	Specifics documents according Morroco regulation	Conformance with Morocco regulations	0700-2400

## TECHNICAL SPECIFICATIONS

30WI			700 V	800 V	900 V	1000 V	1100 V	1200 V	
<b>Heating</b>									
Standard unit Seasonal energy efficiency**	HA1	SCOP <sub>30/35°C</sub>	kW / kW	5,30	5,53	5,45	5,47	5,43	5,49
		η <sub>s heat</sub> <sub>30/35°C</sub>	%	204	213	210	211	209	212
		P <sub>rated</sub>	kW	246	293	335	384	419	463
<b>Cooling</b>									
Standard unit Full load performances*	CA1	Net cooling capacity	kW	203	242	278	320	348	382
		Net power input	kW	49	56	64	71	79	86
		EER	kW / kW	4,18	4,32	4,33	4,5	4,42	4,42
Standard unit Seasonal energy efficiency**		SEPR <sub>-2/-8°C</sub> Process medium temp ***	kWh/kWh	3,04	3,08	3,09	3,04	3,08	3,11
Standard unit Seasonal energy efficiency**		SEER <sub>12/7°C</sub> Comfort Low temp.	kW / kW	4,66	4,96	4,92	4,96	4,91	4,92
Standard unit		Lw / Lp <sup>(1)</sup>	dB(A)	89/57	90/58	90/58	89/57	90/58	91/59
Unit + Low Noise option		Lw / Lp <sup>(1)</sup>	dB(A)	84/52	85/53	85/53	86/54	87/55	88/56
Unit + Xtra Low Noise		Lw / Lp <sup>(1)</sup>	dB(A)	79/47	80/48	80/48	80/48	81/49	82/50
<b>Refrigerating circuit</b>									
Refrigerant (GWP)	R410 (GWP=2088)								
Number	2								
Refrigerant circuit 1	kg	13,5	15,5	16,4	17	19,7	21,3		
Refrigerant circuit 2	kg	14	15	16,4	17,2	19,7	21,3		
Tonne of CO <sub>2</sub> equivalent	TCO <sub>2</sub> Eq	57,42	63,68	68,49	71,41	82,27	88,95		
<b>Compressor</b>									
Type	Hermetic scroll (- 2900 rpm)								
Number	4	4	4	4	4	4	4		
Start-up mode	Direct in line in series								
	Number of stages	6	4	6	4	6	4		
Capacity control	%	100-78-71-50-28-21-0	100-75-50-25-0	100-78-71-50-28-21-0	100-75-50-25-0	100-78-71-50-28-21-0	100-75-50-25-0		
Type of oil for R410A	Polyolester POE								
Oil load per circuit	l	6,7+6,7	6,7+6,7	6,7+6,7	6,7+6,7	6,7+7,2	7,2+7,2		
<b>Evaporator</b>									
Type/ Number	Braze-plate heat exchanger/1								
Water capacity	l	20	23	26	29	32	37		
Victaulic connection	Ø	DN100	DN100	DN100	DN125	DN125	DN125		
Max. pressure, water end	bar	10 bar							
Min/max water flow	m <sup>3</sup> /h	22/70	26/81	29/92	33/105	35/113	38/124		
<b>Water-cooled condenser</b>									
Type/ Number	Braze-plate heat exchanger/1								
Water capacity	l	23	26	29	32	37	40		
Victaulic connection	Ø	DN100	DN100	DN100	DN125	DN125	DN125		
Max. pressure, water end	bar	10 bar							
Min/max water flow	m <sup>3</sup> /h	19/64	22/74	25/84	28/95	31/103	33/112		
<b>Dimensions</b>									
Length	mm	2099	2099	2099	2099	2099	2099		
Width	mm	996							
Height	mm	1869	1869	1869	1869	1869	1869		
<b>Weight</b>									
Weight (empty)	kg	1044	1156	1189	1312	1363	1425		
Weight in operation	kg	1088	1205	1246	1378	1436	1510		
Max. storage temperature	°C	+50°C							

Outputs in accordance with EUROVENT standard EN 14511 conditions

\* In accordance with standard EN14511-3:2022.

\*\* In accordance with standard EN14825:2022, average climate

\*\*\* With EG 30%.

 HA1 Heating mode conditions: Water heat exchanger water entering/leaving temperature 30°C/35°C, outside air temperature tdb/twb = 7°C db/6°C wb, evaporator fouling factor 0 m<sup>2</sup>. kW/W.

 CA1 Cooling mode conditions: evaporator water inlet/outlet temperature 12 °C/7 °C, outdoor air temperature 35 °C, evaporator fouling factor 0 m<sup>2</sup>. kW/W

 η<sub>s heat</sub><sub>30/35°C</sub> & SCOP<sub>30/35°C</sub> Values in bold comply with Ecodesign Regulation (EU) No. 813/2013 for Heating applications.

 SEER<sub>12/7°C</sub> Values calculated according to EN14825:2022.

 SEPR<sub>-2/-8°C</sub> Values in bold comply with Ecodesign Regulation (EU) No. 2015/1095 for Process application

(1) Lw : overall power level in accordance with standard ISO3744

Lp : overall pressure level at 10 metres in a free field calculated using the formula Lp=LW-10logS



Eurovent certified values

## TECHNICAL SPECIFICATIONS

30WI			1400 V	1600 V	1800 V	2100 V	2400 V	
<b>Heating</b>								
<b>Standard unit</b>	HA1	<b>SCOP</b> <sub>30/35°C</sub>	<b>kW / kW</b>	<b>5,49</b>	<b>5,48</b>	<b>5,44</b>	<b>5,46</b>	<b>5,24</b>
Seasonal energy efficiency**		<b>η<sub>s heat</sub></b> <sub>30/35°C</sub>	<b>%</b>	<b>212</b>	<b>211</b>	<b>210</b>	<b>211</b>	<b>202</b>
		<b>P<sub>rated</sub></b>	<b>kW</b>	<b>530</b>	<b>593</b>	<b>687</b>	<b>795</b>	<b>876</b>
<b>Cooling</b>								
<b>Standard unit</b>	CA1	Net cooling capacity	kW	439	495	574	651	703
Full load performances*		Net power input	kW	97	108	125	145	165
		EER	kW / kW	4,55	4,6	4,6	4,49	4,27
<b>Standard unit</b>		<b>SEPR</b> <sub>-2/-8°C</sub>	<b>kWh/kWh</b>	<b>3,21</b>	<b>3,31</b>	<b>3,26</b>	<b>3,33</b>	<b>3,37</b>
Seasonal energy efficiency**		<b>Process medium temp</b> ***						
<b>Standard unit</b>		<b>SEER</b> <sub>12/7°C</sub>	<b>kW / kW</b>	<b>4,98</b>	<b>4,97</b>	<b>4,99</b>	<b>4,89</b>	<b>4,60</b>
Seasonal energy efficiency**		Comfort Low temp.						
Standard unit		Lw / Lp <sup>(1)</sup>	dB(A)	95/63	96/64	93/61	95/63	97/65
Unit + Low Noise option		Lw / Lp <sup>(1)</sup>	dB(A)	90/58	91/59	89/57	90/58	91/59
Unit + Xtra Low Noise		Lw / Lp <sup>(1)</sup>	dB(A)	85/53	86/54	85/53	86/54	87/55
<b>Refrigerating circuit</b>								
Refrigerant (GWP)	R410 (GWP=2088)							
Number	2							
Refrigerant circuit 1	kg	21,5	23	31	33	34		
Refrigerant circuit 2	kg	21	22	31	34	34		
Tonne of CO <sub>2</sub> equivalent	TCO <sub>2</sub> Eq	88,74	93,96	129,46	139,9	141,98		
<b>Compressor</b>								
Type	Hermetic scroll (- 2900 rpm)							
Number	4							
Start-up mode	Direct in line in series							
	Number of stages	6	4	6	8	6		
Capacity control	%	100-78-71-50-28-21-0	100-75-50-25-0	100-83-66-50-33-16-0	100-84-66-48-36-30-18-15-0	100-83-66-50-33-16-0		
Type of oil for R410A	Polyolester POE							
Oil load per circuit	l	6,3+6,3	6,3+6,3	3x6,3	3x6,3	3x6,3		
<b>Evaporator</b>								
Type/ Number	Brazen-plate heat exchanger							
Water capacity	l	50	57	64	77	77		
Victaulic connection	Ø	DN125	DN125	DN150	DN150	DN150		
Max. pressure, water end	bar	10 bar						
Min/max water flow	m <sup>3</sup> /h	44/137	51/151	61/150	68/150	74/150		
<b>Water-cooled condenser</b>								
Type/ Number	Brazen-plate heat exchanger							
Water capacity	l	55	61	73	77	77		
Victaulic connection	Ø	DN125	DN125	DN150	DN150	DN150		
Max. pressure, water end	bar	10 bar						
Min/max water flow	m <sup>3</sup> /h	38/129	43/143	52/150	59/150	66/163		
<b>Dimensions</b>								
Length	mm	2499	2499	3350	3350	3350		
Width	mm	996						
Height	mm	1887	1887	1970	1970	1970		
<b>Weight</b>								
Weight (empty)	kg	1613	1708	2284	2376	2418		
Weight in operation	kg	1713	1818	2472	2588	2637		
<b>Max. storage temperature</b>	°C	+50°C						

Outputs in accordance with EUROVENT standard EN 14511 conditions

\* In accordance with standard EN14511-3:2022.

\*\* In accordance with standard EN14825:2022, average climate

\*\*\* With EG 30%.

HA1 Heating mode conditions: Water heat exchanger water entering/leaving temperature 30°C/35°C, outside air temperature tdb/twb = 7°C db/6°C wb, evaporator fouling factor 0 m<sup>2</sup>. kW.

CA1 Cooling mode conditions: evaporator water inlet/outlet temperature 12 °C/7 °C, outdoor air temperature 35 °C, evaporator fouling factor 0 m<sup>2</sup>. kW

**η<sub>s heat</sub>**<sub>30/35°C</sub> & **SCOP**<sub>30/35°C</sub> **Values in bold comply with Ecodesign Regulation (EU) No. 813/2013 for Heating applications.**

SEER<sub>12/7°C</sub> Values calculated according to EN14825:2022.

**SEPR**<sub>-2/-8°C</sub> **Values in bold comply with Ecodesign Regulation (EU) No. 2015/1095 for Process application**

(1) **Lw** : overall power level in accordance with standard ISO3744

**Lp** : overall pressure level at 10 metres in a free field calculated using the formula Lp=LW-10logS



Eurovent certified values

## ELECTRICAL SPECIFICATIONS

30WI		700 V	800 V	900 V	1000 V	1100 V	1200 V	1400 V	1600 V	1800 V	2100 V	2400 V
<b>COMPRESSOR</b>												
<b>Voltage</b>	V	400V - 3Ph - 50Hz (+10/- 10%)										
<b>Maximum nominal current</b>	A	140	160	182	205	218	232	266	295	356	399	443
<b>Starting current<sup>(1)</sup></b>	A	316	334	391	414	480	494	586	615	607	720	763
<b>Starting current with Soft Start option<sup>(1)</sup></b>	A	230	248	287	310	352	366	429	458	483	562	605
<b>REMOTE CONTROL AUXILIARY CIRCUIT</b>												
<b>Voltage</b>	V	230V - 1Ph - 50Hz (+10/- 10%)										
<b>Maximum nominal current</b>	A	0,8	0,8	0,8	0,8	0,8	0,8	1,3	1,3	1,3	1,3	1,3
<b>Transformer capacity</b>	VA	160	160	160	160	160	160	250	250	250	250	250
<b>Machine protection rating</b>		IP 21										

- (1) Starting current of largest compressor + maximum current of other compressors under full load  
 Cable selection nominal current = sum of maximum nominal currents in above tables



## DIMENSIONS

### 700 V to 1600 V models

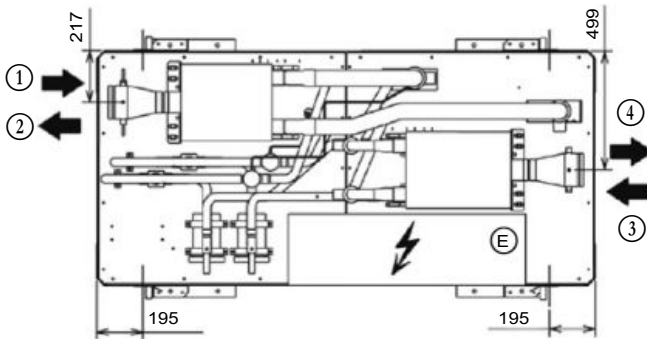
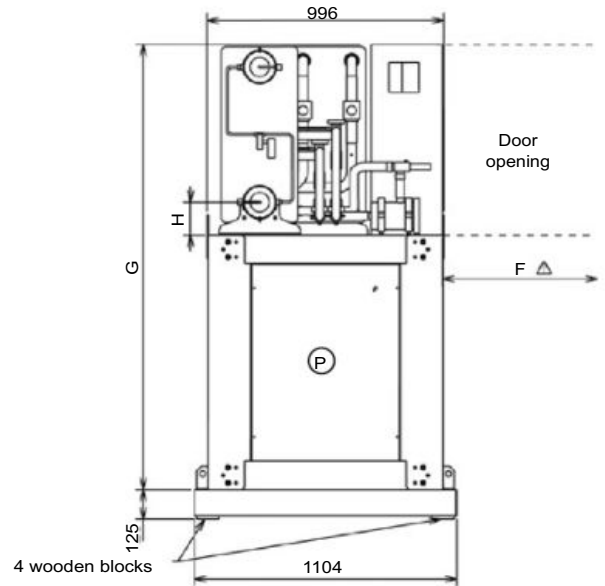
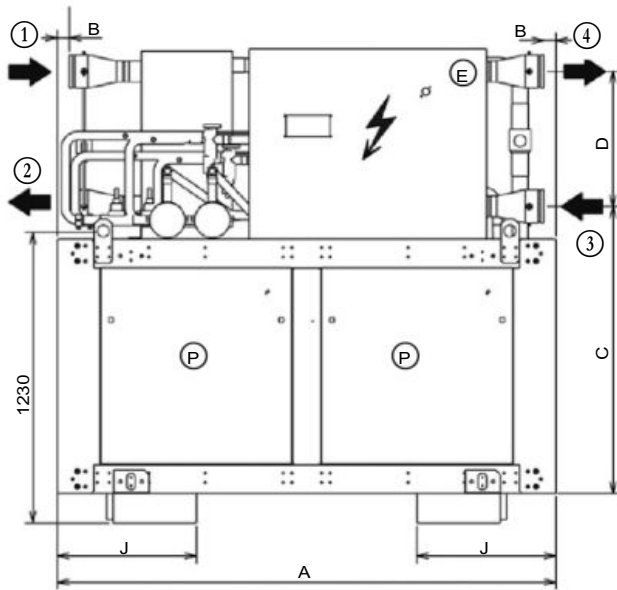

- Ⓔ Electrical connection on the side
- Ⓟ Noise insulation panels option

Models	Dimensions (mm)								Chilled water		Hot water		Weight (kg)	
	A	B	C	D	F	G	H	J	Inlet 1	Outlet 2	Inlet 3	Outlet 4	Empty	In operation
700 V	2099	49	1207	568	1000	1869	137	585	VICTAULIC DN 100				1044	1088
800 V	2099	49	1207	568	1000	1869	137	585					1156	1205
900 V	2099	49	1207	568	1000	1869	137	585					1189	1246
1000 V	2099	49	1207	568	1000	1869	137	585	VICTAULIC DN 125				1312	1378
1100 V	2099	49	1207	568	1000	1869	137	585					1363	1436
1200 V	2099	49	1207	568	1000	1869	137	585					1425	1510
1400 V	2499	60	1240	532	600	1887	170	715					1613	1713
1600 V	2499	60	1240	532	600	1887	170	715					1708	1818

## DIMENSIONS

### 1800 V to 2400 V models

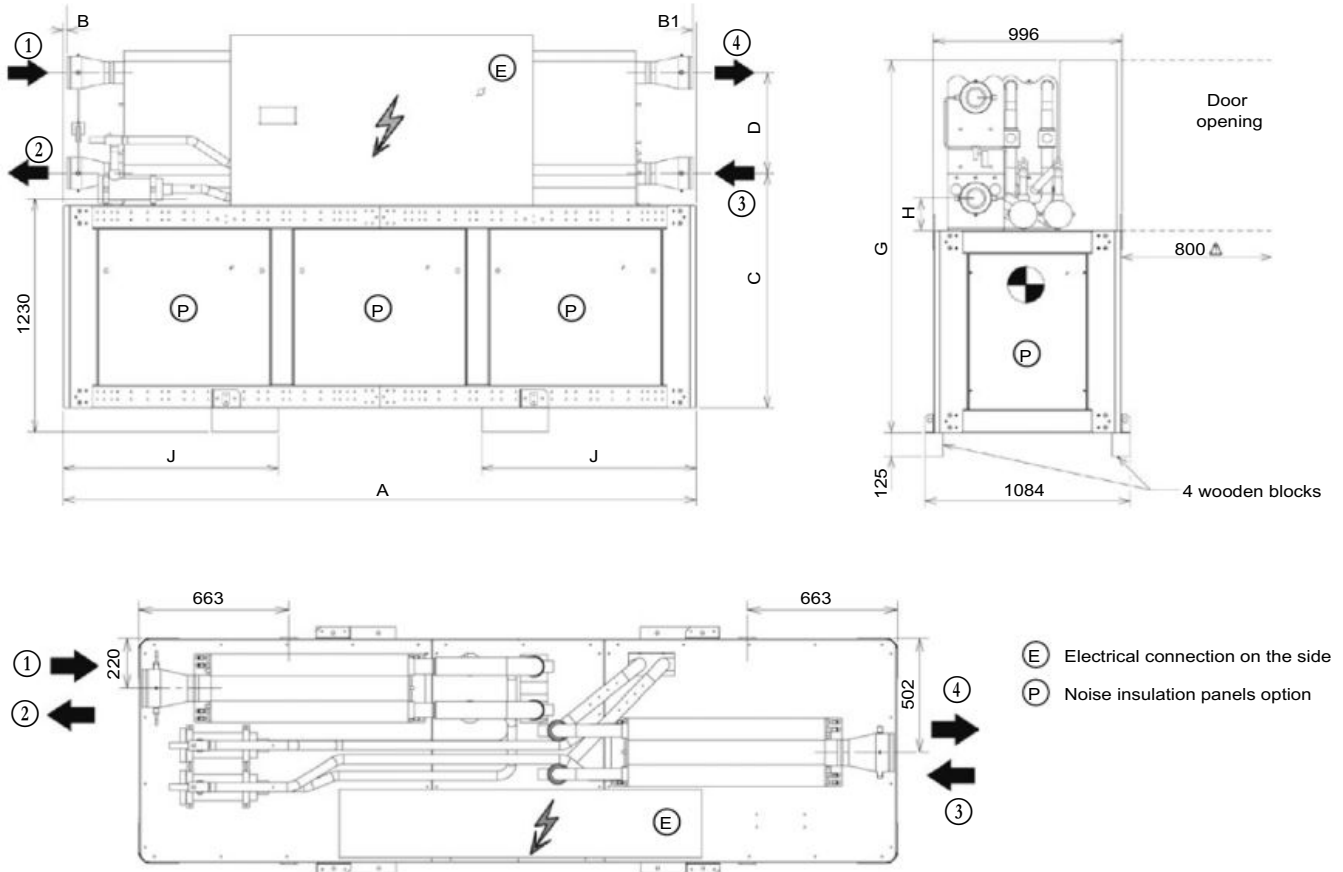

Models	Dimensions (mm)								Chilled water		Hot water		Weight (kg)	
	A	B	B1	C	D	G	H	J	Inlet 1	Outlet 2	Inlet 1	Outlet 2	Empty	In operation
1800 V	3350	63	63	1240	532	1970	170	1135	VICTAULIC DN 150				2284	2472
2100 V	3350	15	15	1240	532	1970	170	1135					2376	2588
2400 V	3350	15	15	1240	532	1970	170	1135					2418	2637



## WATER-SOURCED SCREW HEAT PUMPS



Low energy consumption

High reliability

Safe Design

Easy and fast installation

Minimised operating sound levels

Environmental care

## 30XWHPZE

Nominal heating capacity 322-1297 kW  
Nominal cooling capacity 271-1110 kW

The 30XW-PZE liquid chillers are the premium solution for industrial and commercial applications where installers, consultants and building owners require optimal performances and maximum quality.

The 30XW-PZE liquid chillers are designed to meet current and future requirements in terms of energy efficiency, flexibility of use and compactness. They use the most reliable technologies available today:

- Twin-rotor screw compressors with a variable capacity valve
- R-1234ze refrigerant or R-515B
- Flooded heat exchangers that are mechanically cleanable
- Carrier SmartVu™ control with color touch screen user interface that includes 10 languages

The AquaForce PUREtec range is splitted into two versions:

- 30XW-PZE for air conditioning and refrigeration applications
- 30XWHPZE for heating applications

As standard, the unit can provide an evaporator leaving temperature down to 3,3°C, and when operating as a heat pump, it can deliver up to 55°C (70°C optional) on the condenser side.



CARRIER participates in the ECP programme for LCP-HP  
Check ongoing validity of certificate:  
[www.eurovent-certification.com](http://www.eurovent-certification.com)

## CUSTOMER BENEFITS

### Low energy consumption

- 30XW-PZE range is compliant with EU Eco-design Minimum Efficiency Performance Standards (MEPS) in cooling that apply from January 2021
- SEER 12/7°C up to 7.6 and SEPR 12/7°C up to 9.3
- 30XWHPZE range is compliant with EU Eco-design Minimum Efficiency Performance Standards (MEPS) in heating that apply from September 2015
- COP of up to 6.7 and SCOP up to 7.2
- The high energy efficiency is reached through:
  - Twin-rotor screw compressor equipped with a high-efficiency motor and a variable capacity valve that permits exact matching of the cooling capacity to the load.
  - Flooded multi-pipe heat exchangers for increased heat exchange efficiency.
  - Electronic expansion device permitting operation at a lower condensing pressure and improved utilisation of the evaporator heat exchange surface.
  - Economizer system with electronic expansion device for increased cooling capacity.

### Low operating sound levels

- Standard unit features include:
  - Silencers on the compressors discharge line.
  - Silencers on the economiser return line.
  - Acoustic insulation on the components that are most subjected to radiated noise.
  - Option 257 further reduces the global unit sound level.

### Easy and fast installation

- Compact design
  - The 30XW units are designed to offer the most compact dimensions on the market.
  - With a width of approximately 1 m up to 1300 kW the units can pass through standard door openings and only require minimum floor space in the plant room.

### Compact, accessible unit - side view - sizes up to 1300 KW

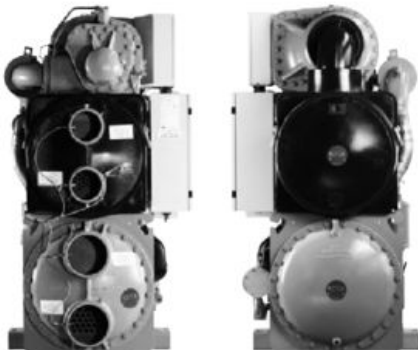

- Simplified electrical connections
  - Main disconnect switch with high trip capacity
  - Transformer to supply the integrated control circuit (400/24 V)
- Simplified hydraulic connections
  - Victaulic connections on the evaporator and condenser
  - Practical reference marks for entering and leaving water connections
  - Possibility to reverse the heat exchanger water inlet and outlet at the factory
  - Possibility to modify the number of heat exchanger passes
- Fast commissioning
  - Systematic factory operation test before shipment
  - Quick-test function for step-by-step verification of the instruments, expansion devices and compressors.

### Environmental care



- R-1234ze long-term refrigerant solution
  - HFO refrigerant with nearly zero global warming potential (GWP < 1) and zero ozone depletion potential (ODP = 0).
  - Not impacted by the HFC phase-down plan in Europe (79% HFC reduction in EU member states at 2030 horizon)
  - Compliant with refrigerant regulation in Switzerland that bans the use of HFC refrigerant in large capacity air-conditioning equipment.
- Leak-tight refrigerant circuit
  - Reduction of leaks as no capillary tubes and flare connections are used
  - Verification of pressure transducers and temperature sensors without transferring refrigerant charge
  - Discharge line shut-off valve and liquid line service valve for simplified maintenance.

### High reliability and easy servicing

- The 30XW units offer increased global performance as well as Carrier's acclaimed product quality and reliability.
- Major components are selected and tested with R-1234ze and R-515B refrigerant to minimize failures possibility, as well as many design choices have been taken in this perspective.
- Non flammable use possible when selecting option 330, Low GWP A1 R-515 Refrigerant
- Screw compressors
  - Industrial-type screw compressors with oversized bearings and motor cooled by suction gas.
  - All compressor components are easily accessible on site minimising down-time.
- Refrigerant circuit
  - Two independent refrigerant circuits (from 1000 kW upwards); the second one automatically takes over, if the first one develops a fault, maintaining partial cooling under all circumstances.
- Evaporator
  - Electronic paddle-free flow switch. Auto-setting according to cooler size and fluid type.
- Auto-adaptive control
  - Control algorithm prevents excessive compressor cycling (Carrier patent)
  - Automatic compressor unloading in case of abnormally high condensing pressure.
- Exceptional endurance tests
  - Partnerships with specialised laboratories and use of limit simulation tools (finite element calculation) for the design of critical components.
  - Transport simulation test in the laboratory on a vibrating table and then on an endurance circuit (based on a military standard).



## CUSTOMER BENEFITS

### Safe Design

- Specific polyol ester oil qualified by Carrier for using with HFO-1234ze or R-515B to guarantee and maintain reliable bearing lubrication.
- Specific compressor gaskets compatible with HFO-1234ze or R-515B, tested and validated by Carrier.
- New relief valves designed for operation with HFO-1234ze or R-515B
- Specific electrical box with increased tightness and integrated blower that maintains positive air pressure to avoid any risk of ignition when using R-1234ze refrigerant.
- No need of ducted electrical cabinet fresh air supply when using option 330 - LOW GWP A1 R-515B refrigerant
- New control algorithms
- Specific documentation that contains all the installation, operation, maintenance and safety Instructions.

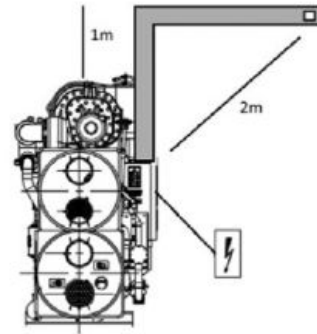

## TECHNICAL INSIGHTS

### SmartVu™ Control

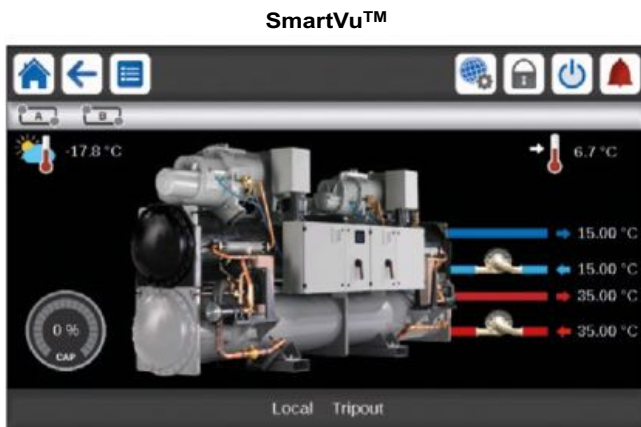

- New innovative smart control features:
  - An intuitive and user-friendly, coloured, 7" interface
  - 10 languages available on choice: DE, EN, ES, FR, IT, NL, PT, TR, TU + one additional customer choice
  - Screen-shots with concise and clear information in local languages
  - Complete menu, customised for different users (end user, service personnel and Carrier-factory technicians)
  - Setpoint offset based on the outside air temperature
  - Safe operation and unit setting: Password protection ensures that unauthorised people cannot modify any advanced parameters
  - Simple and "smart" intelligence uses data collection from the constant monitoring of all machine parameters to optimise unit operation
  - Night-mode: Cooling capacity management for reduced noise level.
  - With hydraulic module: Water pressure display and water flow rate calculation
- Energy management:
  - Internal time schedule clock controls chiller on/off times and operation at a second set-point
  - The DCT (Data Collection Tool) records the alarms history to simplify and facilitate service operations.

- Maintenance functions
  - F-Gas regulation leak check reminder alert
  - aintenance alert can be configured to days, months or hours of operation
- Advanced communication features
  - Easy and high-speed communication technology over Ethernet (IP) to a centralised building management system
  - Access to multiple unit parameters

### Remote Management (Standard)

- Units with SmartVu™ control can be easily accessed from the internet, using a PC with an Ethernet connection. This makes remote control quick and easy and offers significant advantages for service operations.
- Aquaforce with Greenspeed® Intelligence is equipped with an RS485 serial port that offers multiple remote control, monitoring and diagnostic possibilities. When networked with other Carrier equipment through the CCN (Carrier Comfort Network - proprietary protocol), all components form a HVAC system fully-integrated and balanced through one of the Carrier's network system products, like the Chiller System anager or the Plant System anager (optional)
- The 30XWZE/30XWPZE also communicates with other building management systems via optional communication gateways (BACnet, LON or JBus).
- The following commands/visualisations are possible from remote connection:
  - Start/Stop of the machine
  - Dual set-point management: Through a dedicated contact is possible to activate a second set-point (example, unoccupied mode)
  - Demand limit setting: To limit the maximum chiller capacity to a predefined value
  - Water pump control: These outputs control the contactors of one/two evaporator water pumps.
  - Water pumps changeover (only with hydraulic module options): These contacts are used to detect a water pump operation fault and automatically change over to the other pump.
  - Operation visualisation: ndication if the unit is operating or if it is in stand-by (no cooling load).
  - Alarm visualisation.

## TECHNICAL INSIGHTS

### Remote management (EMM option)

- The Energy management module (EMM) offers extended remote control possibilities:
- Room temperature: Permits set-point reset based on the building indoor air temperature (if Carrier thermostats are installed)
- Set-point reset: Allows reset of the cooling set-point based on a 4-20 mA or 0-10 V signal
- Demand limit: Permits limitation of the maximum chiller capacity based on 0-10 V signal
- Demand limit 1 and 2: Closing of these contacts limits the maximum chiller capacity to two predefined values.
- User safety: This contact can be used for any customer safety loop; opening the contact generates a specific alarm.
- Ice storage end: When ice storage has finished, this input permits return to the second set-point (unoccupied mode).
- Time schedule override: Closing of this contact cancels the programmed time schedule.
- Out of service: This signal indicates that the chiller is completely out of service.
- Chiller capacity: This analogue output (0-10) gives an immediate indication of the chiller capacity.
- Alert indication: This volt-free contact indicates the necessity to carry out a maintenance operation or the presence of a minor fault.
- Compressors running status: Set of outputs (as many as the compressors number) indicating which compressors are running

### 06T screw compressor

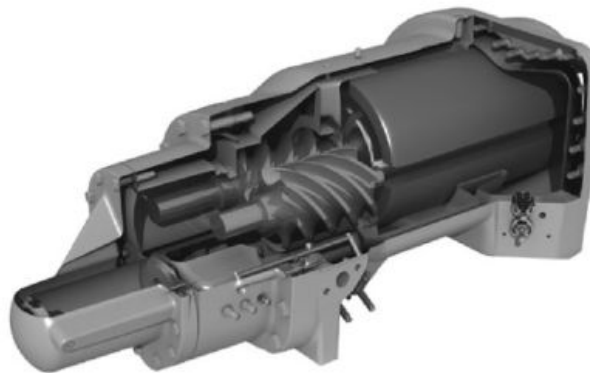

The Carrier 06T screw compressor designed for operation with HFO-1234ze and R-515B refrigerant benefits from Carrier's long experience in the development of twin-rotor screw compressors. The compressor is equipped with bearings with oversized rollers, oil pressure lubricated for reliable and durable operation, even at maximum load.

A variable control valve controlled by the oil pressure permits infinitely variable cooling capacity. This system allows optimal adjustment of the compressor cooling capacity and ensures exceptionally high stability of the chilled water leaving temperature.

Among the other advantages: if a fault occurs e.g. if the condenser is fouled or at very high water temperature, the compressor does not switch off, but continues operation with a reduced capacity (unloaded mode).

The silencer in the discharge line considerably reduces discharge gas pulsations for much quieter operation.

The condenser includes an oil separator that minimises the amount of oil in circulation in the refrigerant circuit and re-directs it to the compressor function.

### Digit number

1	2	3	4	5	6	7	8	9	1	1	1	1	1	1	1	1	1
3	0	X	W	-	P	Z	E	0	3	0	1	B	0	0	0	1	-

**Legend :**

- Digit 1 to 4 : Water-cooled chiller with screw compressor
- Digit 5 : Application type, - = Cooling, H = Heating
- Digit 6 : Efficiency, - = standard, P = premium
- Digit 7 & 8 : Unit using R1234ze refrigerant
- Digit 9 to 12 : Model number based on cooling capacity in kW
- Digit 13 : Index for major product modification (visible impact for customer)
- Digit 14 to 17 : Counter used to generate a one time product code
- Digit 18 : Not used

## OPTIONS

Options	N°	Description	Advantages	Use
Light-brine solution, down to -3°C	8	Implementation of new algorithms of control to allow chilled brine solution production down to -3°C when ethylene glycol is used (0°C with propylene glycol)	Matches with most application requirements for ground-sourced heat pumps and fits with many industrial processes requirements	301-1101
Master/slave operation	58	Unit equipped with supplementary water outlet temperature sensor kit to be field-installed allowing master/slave operation of two units connected in parallel	Optimised operation of two units connected in parrallele operation with operating time equalisation	301-1101
Single power connection point	81	Unit power connection via one main supply connection	Quick and easy installation	801-1101
Evap. pump power/control circuit	84	Unit equipped with an electrical power and control circuit for one pump evaporator side	Quick and easy installation: the control of fixed speed pumps is embedded in the unit control	301-1001
Evap. dual pumps power/control circuit	84D	Unit equipped with an electrical power and control circuit for two pumps evaporator side	Quick and easy installation: the control of fixed speed pumps is embedded in the unit control	301-1001
Cond. pump power/control circuit	84R	Unit equipped with an electrical power and control circuit for one pump condenser side	Quick and easy installation: the control of fixed speed pumps is embedded in the unit control	301-1001
Condenser insulation	86	Thermal condenser insulation	Minimizes thermal dispersions condenser side (key option for heat pump or heat recovery applications) and allows compliancy with special installation criteria (hot parts insulated)	301-1101
Service valve set	92	Liquid line valve (evaporator inlet) and compressor suction line valve	Allow isolation of various refrigerant circuit components for simplified service and maintenance	301-1101
Evaporator with one pass less	100C	Evaporator with one pass on the water side. Evaporator inlet and outlet on opposite sides.	Easy to install, depending on site. Reduced pressure drops	301-1101
Condenser with one pass less	102C	Condenser with one pass on the water side. Condenser inlet and outlet on opposite sides.	Easy to install, depending on site. Reduced pressure drops	301-1101
21 bar evaporator	104	Reinforced evaporator for extension of the maximum water-side service pressure to 21 bar (standard 10 bar)	Covers applications with a high water column evaporator side (typically high buildings)	301-1101
21 bar condenser	104A	Reinforced condenser for extension of the maximum water-side service pressure to 21 bar (standard 10 bar)	Covers applications with a high water column condenser side (typically high buildings)	301-1101
Reversed evaporator water connections	107	Evaporator with reversed water inlet/outlet	Easy installation on sites with specific requirements	301-1101
Reversed condenser water connections	107A	Condenser with reversed water inlet/outlet	Easy installation on sites with specific requirements	301-1101
Lon gateway	148D	Two-directional communication board complying with Lon Talk protocol	Connects the unit by communication bus to a building management system	301-1101
Bacnet over IP	149	Two-directional high-speed communication using BACnet protocol over Ethernet network (IP)	Easy and high-speed connection by ethernet line to a building management system. Allows access to multiple unit parameters	301-1101
Modbus over IP and RS485	149B	Bi-directional high-speed communication using Modbus protocol over Ethernet network (IP)	Easy and high-speed connection by ethernet line to a building management system. Allows access to multiple unit parameters	301-1101
High condensing temperature	150	Optimized compressor for operation at high condensing temperature	Increased condenser leaving water temperature up to 70°C. Allows applications with high condensing temperature (heat pumps, installations with not generously sized dry-coolers or more generally, installations with dry-coolers in hot climate). NOTE: to ensure control of the condenser leaving water temperature, this option must be fitted with 30XWH units.	301-1101
Condensing temperature limitation	150B	Limitation of the maximum condenser leaving water temperature to 45°C	Reduced maximum power input and current absorption: power cables and protection elements can therefore be downsized	301-1101
Control for low cond. temperature systems	152	Output signal (0-10 V) to control the condenser water inlet valve	Simple installation: for applications with cold water at condenser inlet (ex. ground-source, groundwater-source, superficial water-source applications) the signal permits to control a 2 or 3-way valve to maintain condenser water temperature (and so condensing pressure) at acceptable values	301-1101

## OPTIONS

Options	N°	Description	Advantages	Use
Dry-cooler control	154	Adaptation of the control box for communication with the dry-cooler via a bus. For dry cooler need to select the cabinet with option control cabinet manage by the chiller control	Easy system management, extended control capabilities of a remote dry-cooler	301-1101
Energy Management Module	156	EMM Control board with additional inputs/ outputs. See Energy Management Module option chapter	Extended remote control capabilities (Set-point reset, ice storage end, demand limits, boiler on/off command...)	301-1101
SmartVu™control, 7" user interface	158A	SmartVu™control supplied with a 7 inch colour touch screen user interface	Enhanced ease of use.	301-1101
Dual relief valves on 3-way valve	194	Three-way valve upstream of dual relief valves on the shell and tubes evaporator	Valve replacement and inspection facilitated without refrigerant loss. Comforms to European standard EN378/BGVD4	301-1101
Compliance with Swiss regulations	197	Additional tests on the water heat exchangers: supply (additional of PED documents) supplementary certificates and test certifications	Conformance with Swiss regulations	301-1101
Compliance with Australian regulations	200	Unit approved to Australian code	Conformance with Australian regulations	301-1101
Low noise level	257	Evaporator sound insulation	3 dB(A) quieter than standard unit	401-1101
Welded evaporator connection kit	266	Victaulic piping connections with welded joints	Easy installation	301-1101
Welded condenser water connection kit	267	Victaulic piping connections with welded joints	Easy installation	301-1101
Flanged evaporator water connection kit	268	Victaulic piping connections with flanged joints	Easy installation	301-1101
Flanged condenser water connection kit	269	Victaulic piping connections with flanged joints	Easy installation	301-1101
Thermal compressor insulation	271	The compressor is covered with a thermal insulation layer	Prevents air humidity to condensate on the compressor surface	301-1101
Free-cooling dry-cooler control	313	Control & connections to a Free Cooling Drycooler 09PE or 09VE fitted with option FC control box	Easy system management, Extended control capabilities to a dryccoler used in Free Cooling mode	301-1101
Low GWP A1 R-515B refrigerant	330	Unit delivered with R-515B refrigerant charge (A1, GWP 299)	Reduced CO <sub>2</sub> footprint (GWP < 300) A1 safety class Reduced installed cost in technical room	301-1101

## PHYSICAL DATA, STANDARD UNITS

30XW-PZE / 30XWHPZE				301	401	451	551	601	651	801	901	1001	1101
<b>Heating</b>													
<b>Standard unit</b> Full load performances*	HW1	Nominal capacity	kW	322	448	509	657	698	758	916	1012	1168	1297
		COP	kW/kW	6,12	6,55	6,47	6,63	6,48	6,47	6,52	6,49	6,50	6,30
	HW2	Nominal capacity	kW	318	439	500	646	686	741	900	991	1146	1271
		COP	kW/kW	4,66	4,94	4,88	4,99	4,85	4,89	4,95	4,92	4,95	4,80
	HW3	Nominal capacity	kW	315	433	494	638	678	725	890	976	1129	1251
		COP	kW/kW	3,65	3,82	3,80	3,84	3,74	3,80	3,83	3,82	3,86	3,73
<b>Standard unit</b> Seasonal energy efficiency**	HW1	SCOP <sub>30/35°C</sub>	kW/kW	6,20	6,74	6,81	6,48	6,53	6,57	6,79	6,97	6,88	6,51
		$\eta_s$ heat <sub>30/35°C</sub>	%	240	262	264	251	253	255	264	271	267	252
	HW3	SCOP <sub>47/55°C</sub>	kW/kW	4,43	5,04	4,99	4,49	4,60	4,73	5,07	5,09	4,95	4,62
		$\eta_s$ heat <sub>47/55°C</sub>	%	169	194	192	171	176	181	195	195	190	177
		P <sub>rated</sub>	kW	411	540	615	795	845	908	1108	1218	1408	1562
	<b>Cooling</b>												
<b>Standard unit</b> Full load performances*	CW1	Nominal capacity	kW	271	385	435	561	595	648	783	874	1001	1111
		EER	kW/kW	5,28	5,75	5,66	5,80	5,66	5,69	5,74	5,83	5,80	5,65
	CW2	Nominal capacity	kW	375	538	610	764	813	880	1086	1220	1383	1522
		EER	kW/kW	8,00	8,15	7,99	8,55	8,17	8,33	8,10	8,13	8,27	8,13
<b>Standard unit</b> Seasonal energy efficiency**		SEER <sub>12/7°C</sub> Comfort low temp.	kWh/kWh	<b>6,43</b>	<b>7,03</b>	<b>7,35</b>	<b>6,54</b>	<b>6,65</b>	<b>6,97</b>	<b>7,10</b>	<b>7,59</b>	<b>7,61</b>	<b>7,14</b>
		$\eta_s$ cool <sub>12/7°C</sub>	%	<b>254</b>	<b>278</b>	<b>291</b>	<b>259</b>	<b>263</b>	<b>276</b>	<b>281</b>	<b>301</b>	<b>301</b>	<b>283</b>
		SEPR <sub>12/7°C</sub> Process high temp.	kWh/kWh	<b>9,27</b>	<b>8,76</b>	<b>8,75</b>	<b>9,36</b>	<b>8,78</b>	<b>8,84</b>	<b>8,76</b>	<b>9,06</b>	<b>9,26</b>	<b>9,19</b>

\* In accordance with standard EN14511-3:2022

\*\* In accordance with standard EN14825:2022, average climate

HW1 Heating mode conditions: Evaporator entering/leaving water temperature 10°C/7°C, condenser entering/leaving water temperature 30°C/35°C, evaporator and condenser fouling factor 0 m<sup>2</sup>.k/W

HW2 Heating mode conditions: Evaporator entering/leaving water temperature 10°C/7°C, condenser entering/leaving water temperature 40°C/45°C, evaporator and condenser fouling factor 0 m<sup>2</sup>.k/W

HW3 Heating mode conditions: Evaporator entering/leaving water temperature 10°C/7°C, condenser entering/leaving water temperature 47°C/55°C, evaporator and condenser fouling factor 0 m<sup>2</sup>.k/W

CW1 Cooling mode conditions: Evaporator water entering/leaving temperature 12°C/7°C, condenser entering/leaving water temperature 30°C/35°C, evaporator and condenser fouling factor 0 m<sup>2</sup>.K/W

CW2 Cooling mode conditions: Evaporator water entering/leaving temperature 23°C/18°C, condenser entering/leaving water temperature 30°C/35°C, evaporator and condenser fouling factor 0 m<sup>2</sup>.K/W

$\eta_s$  heat<sub>30/35°C</sub> & SCOP<sub>30/35°C</sub> Values calculated in accordance with EN14825:2022

$\eta_s$  heat<sub>47/55°C</sub> & SCOP<sub>47/55°C</sub> Values calculated in accordance with EN14825:2022

$\eta_s$  cool<sub>12/7°C</sub> & SEER<sub>12/7°C</sub> **Bold values compliant to Ecodesign regulation: (EU) No 2016/2281 for Comfort application**

SEPR<sub>12/7°C</sub> **Bold values compliant to Ecodesign regulation: (EU) No 2016/2281 for Process application**



Eurovent certified values



## PHYSICAL DATA, STANDARD UNITS

30XW-PZE / 30XWHPZE		301	401	451	551	601	651	801	901	1001	1101
<b>Sound levels - standard unit</b>											
Sound power level <sup>(1)</sup>	dB(A)	93	97	97	97	97	97	100	100	100	100
Sound pressure level at 1 m <sup>(2)</sup>	dB(A)	76	80	80	79	79	79	81	81	81	81
<b>Sound levels - standard unit + option 257 <sup>(3)</sup></b>											
Sound power level <sup>(1)</sup>	dB(A)	-	94	94	94	94	94	97	97	97	97
Sound pressure level at 1 m <sup>(1)</sup>	dB(A)	-	76	76	76	76	76	78	78	78	78
<b>Dimensions - standard unit</b>											
Length	mm	2724	3059	3059	3290	3290	3290	4730	4730	4730	4730
Width	mm	928	936	936	1069	1069	1069	1039	1039	1162	1162
Height	mm	1567	1743	1743	1950	1950	1950	1997	1997	2051	2051
<b>Operating weight <sup>(4)</sup></b>											
	kg	2157	3050	3050	3942	3977	3995	6932	7010	7665	7875
Compressors Semi-hermetic 06T screw compressors, 50 r/s											
Circuit A	-	1	1	1	1	1	1	1	1	1	1
Circuit B	-	-	-	-	-	-	-	1	1	1	1
<b>Refrigerant - standard unit</b>											
R-1234ze											
Circuit A	kg	78	130	130	180	175	170	120	120	130	130
	teq CO <sub>2</sub>	0,5	0,9	0,9	1,3	1,2	1,2	0,8	0,8	0,9	0,9
Circuit B	kg	-	-	-	-	-	-	120	120	150	130
	teq CO <sub>2</sub>	-	-	-	-	-	-	0,8	0,8	1,1	0,9
<b>Refrigerant - option 330</b>											
R-515B											
Circuit A	kg	79	132	132	183	178	173	122	122	132	132
	teq CO <sub>2</sub>	23,1	38,7	38,7	53,6	52,2	50,7	35,7	35,7	38,7	38,7
Circuit B	kg	-	-	-	-	-	-	122	122	152	132
	teq CO <sub>2</sub>	-	-	-	-	-	-	35,7	35,7	44,5	38,7
<b>Oil - standard unit</b>											
HATCOL-4496											
Circuit A	l	20	20	20	25	25	25	20	20	25	25
Circuit B	l	-	-	-	-	-	-	20	20	20	25
<b>Capacity control</b>											
SmartVu™, electronic expansion valves (EXV)											
Minimum capacity	%	30	30	30	15	15	30	30	30	15	15
<b>Evaporator</b>											
Multi-pipe flooded type											
Water volume	l	61	101	101	154	154	154	293	293	321	321
Water connections (Victaulic)	in	5	6	6	8	8	8	8	8	8	8
Drain and vent connections (NPT)	in	3/8	3/8	3/8	3/8	3/8	3/8	3/8	3/8	3/8	3/8
Max. water-side operating pressure	kPa	1000	1000	1000	1000	1000	1000	1000	1000	1000	1000
<b>Condenser</b>											
Multi-pipe flooded type											
Water volume	l	55	103	103	148	148	148	316	316	340	340
Water connections (Victaulic)	in	5	6	6	8	8	8	8	8	8	8
Drain and vent connections (NPT)	in	3/8	3/8	3/8	3/8	3/8	3/8	3/8	3/8	3/8	3/8
Max. water-side operating pressure	kPa	1000	1000	1000	1000	1000	1000	1000	1000	1000	1000

(1) In dB ref=10<sup>-12</sup> W, (A) weighting. Declared dualnumber noise emission values in accordance with ISO 4871 (with an associated uncertainty of +/-3dB(A)). Measured in accordance with ISO 9614-1 and certified by Eurovent.

(2) In dB ref 20µPa, (A) weighting. Declared dualnumber noise emission values in accordance with ISO 4871 (with an associated uncertainty of +/-3dB(A)). For information, calculated from the sound power level Lw(A).

(3) Option 257 = Low noise level

(4) Weight shown is guideline only. Please refer to the unit nameplate

## ELECTRICAL DATA, STANDARD UNITS

30XW-PZE / 30XWHPZE		301	401	451	551	601	651	801	901	1001	1101
<b>Power circuit</b>											
Nom. power supply	V-ph-Hz	400-3-50									
<b>Voltage range</b>	V	360-440									
<b>Control circuit</b>											
24 V via the built-in transformer											
Nominal start-up current <sup>(1)</sup>											
Circuit A	A	303	414	414	587	587	587	414	414	587	587
Circuit B	A	-	-	-	-	-	-	414	414	414	587
Option 81	A	-	-	-	-	-	-	529	543	716	751
<b>Maximum start-up current<sup>(2)</sup></b>											
Circuit A	A	303	414	414	587	587	587	414	414	587	587
Circuit B	A	-	-	-	-	-	-	414	414	414	587
Option 81	A	-	-	-	-	-	-	597	621	794	855
<b>Cosine phi</b>											
Nominal <sup>(3)</sup>		0,79	0,86	0,87	0,85	0,87	0,89	0,86	0,87	0,85	0,85
Maximum <sup>(4)</sup>		0,90	0,90	0,90	0,90	0,90	0,90	0,90	0,90	0,90	0,90
Total harmonic distortion <sup>(4)</sup>	%	Closed to 0% (negligible)									
<b>Maximum power input<sup>(5)</sup></b>											
Circuit A	kW	86	112	126	148	165	174	112	126	148	148
Circuit B	kW	-	-	-	-	-	-	112	126	126	148
Option 81	kW	-	-	-	-	-	-	224	252	274	296
<b>Nominal current drawn<sup>(3)</sup></b>											
Circuit A	A	91	115	129	164	177	194	115	129	164	164
Circuit B	A	-	-	-	-	-	-	115	129	129	164
Option 81	A	-	-	-	-	-	-	230	258	293	328
<b>Maximum current drawn (Un)<sup>(5)</sup></b>											
Circuit A	A	140	180	205	240	268	282	180	205	240	240
Circuit B	A	-	-	-	-	-	-	180	205	205	240
Option 81	A	-	-	-	-	-	-	360	410	445	480
<b>Maximum current drawn (Un -10%)<sup>(4)</sup></b>											
Circuit A	A	153	196	223	261	292	307	196	223	261	261
Circuit B	A	-	-	-	-	-	-	196	223	223	261
Option 81	A	-	-	-	-	-	-	392	446	484	522
<b>Maximum power input with option 150B<sup>(5)</sup></b>											
Circuit A	kW	76	97	110	129	146	153	97	110	129	129
Circuit B	kW	-	-	-	-	-	-	97	110	110	129
Option 81	kW	-	-	-	-	-	-	195	220	239	258
<b>Maximum current drawn (Un) with option 150B<sup>(5)</sup></b>											
Circuit A	A	123	158	179	209	237	249	158	179	209	209
Circuit B	A	-	-	-	-	-	-	158	179	179	209
Option 81	A	-	-	-	-	-	-	316	358	388	418

- (1) Instantaneous start-up current (maximum operating current of the smallest compressor(s) + locked rotor current or reduced start-up current of the largest compressor). Values obtained at standard Eurovent conditions: evaporator entering/leaving water temp. = 12°C/7°C, condenser entering/leaving water temp. = 30°C/35°C.
- (2) Instantaneous start-up current (maximum operating current of the smallest compressor(s) + locked rotor current or reduced start-up current of the largest compressor). Values obtained at operation with maximum unit power input.
- (3) Values obtained at standard Eurovent conditions: evaporator entering/leaving water temp. = 12°C/7°C, condenser entering/leaving water temp. = 30°C/35°C.
- (4) Values obtained at operation with maximum unit power input.
- (5) Values obtained at operation with maximum unit power input. Values given on the unit nameplate.

**PHYSICAL DATA, UNITS FOR HIGH CONDENSING TEMPERATURES (OPTION 150)**

30XW-ZE / 30XWHZE	301	401	451	551	601	651	801	901	1001	1101
-------------------	-----	-----	-----	-----	-----	-----	-----	-----	------	------

**Heating**

<b>Unit + option 150</b> Full load performances*	HW1	Nominal capacity	kW	319	462	516	642	697	771	912	1057	1159	1297
		COP	kW/kW	5,61	6,01	6,05	5,83	5,71	5,93	5,76	5,98	5,73	5,61
	HW2	Nominal capacity	kW	310	446	498	623	678	753	880	1018	1123	1260
		COP	kW/kW	4,59	4,93	4,97	4,8	4,7	4,91	4,74	4,93	4,74	4,66
	HW3	Nominal capacity	kW	302	433	482	605	661	734	853	983	1089	1223
		COP	kW/kW	3,78	4,05	4,09	3,95	3,88	4,06	3,89	4,06	3,94	3,88
	HW4	Nominal capacity	kW	293	420	467	585	645	715	828	950	1057	1186
		COP	kW/kW	3,07	3,29	3,32	3,21	3,16	3,29	3,15	3,29	3,21	3,18
<b>Unit + option 150</b> Seasonal energy efficiency**	HW1	SCOP <sub>30/35°C</sub>	kWh/kWh	5,8	6,18	6,25	6,38	6,28	6,29	6,21	6,31	6,26	6,3
		ηs heat <sub>30/35°C</sub>	%	224	239	242	247	243	244	240	244	242	244
	HW3	SCOP <sub>47/55°C</sub>	kWh/kWh	4,7	4,77	4,83	4,86	4,84	4,9	4,77	4,87	4,84	4,89
		ηs heat <sub>47/55°C</sub>	%	180	183	185	186	186	188	183	187	186	187
	P <sub>rated</sub>		kW	421	544	607	761	829	922	1073	1240	1371	1539

**Cooling**

<b>Unit + option 150</b> Full load performances*	CW1	Nominal capacity	kW	269	393	439	547	591	656	776	910	985	1101
		EER	kW/kW	4,86	5,2	5,27	5,07	4,95	5,18	5,05	5,34	5,03	4,94
	CW2	Nominal capacity	kW	352	538	605	725	782	877	1057	1251	1332	1466
		EER	kW/kW	5,58	6,44	6,4	6,24	6,12	6,42	6,23	6,45	6,16	6,06
<b>Unit + option 150</b> Seasonal energy efficiency**	<b>SEER<sub>12/7°C</sub> Comfort low temp.</b>		<b>kWh/kWh</b>	<b>6,24</b>	<b>6,57</b>	<b>6,65</b>	<b>6,52</b>	<b>6,57</b>	<b>6,5</b>	<b>6,67</b>	<b>6,8</b>	<b>6,63</b>	<b>6,6</b>
	ηs cool <sub>12/7°C</sub>		%	<b>247</b>	<b>260</b>	<b>263</b>	<b>258</b>	<b>260</b>	<b>257</b>	<b>264</b>	<b>269</b>	<b>262</b>	<b>261</b>
	SEPR <sub>12/7°C</sub> Process high temp.		kWh/kWh	6,80	7,01	7,07	7,39	6,97	6,99	6,96	7,23	7,11	7,30

\* In accordance with standard EN14511-3:2022  
 \*\* In accordance with standard EN14825:2022, average climate  
 HW1 Heating mode conditions: Evaporator entering/leaving water temperature 10°C/7°C, condenser entering/leaving water temperature 30°C/35°C, evaporator and condenser fouling factor 0 m². kW  
 HW2 Heating mode conditions: Evaporator entering/leaving water temperature 10°C/7°C, condenser entering/leaving water temperature 40°C/45°C, evaporator and condenser fouling factor 0 m². kW  
 HW3 Heating mode conditions: Evaporator entering/leaving water temperature 10°C/7°C, condenser entering/leaving water temperature 47°C/55°C, evaporator and condenser fouling factor 0 m². kW  
 HW4 Heating mode conditions: Evaporator entering/leaving water temperature 10°C/7°C, condenser entering/leaving water temperature 55°C/65°C, evaporator and condenser fouling factor 0 m². kW  
 CW1 Cooling mode conditions: Evaporator water entering/leaving temperature 12°C/7°C, outside air temperature 35°C, evaporator fouling factor 0 m².K/W  
 CW2 Cooling mode conditions: Evaporator water entering/leaving temperature 23°C/18°C, outside air temperature 35°C, evaporator fouling factor 0 m².K/W  
 ηs heat<sub>30/35°C</sub> & SCOP<sub>30/35°C</sub> Values calculated in accordance with EN14825:2022  
 ηs heat<sub>47/55°C</sub> & SCOP<sub>47/55°C</sub> Values calculated in accordance with EN14825:2022  
**ηs cool<sub>12/7°C</sub> & SEER<sub>12/7°C</sub> Bold values compliant to Ecodesign regulation: (EU) No 2016/2281 for Comfort application**  
 SEPR<sub>12/7°C</sub> Values calculated in accordance with EN14825:2022



Eurovent certified values

## PHYSICAL DATA, UNITS FOR HIGH CONDENSING TEMPERATURES (OPTION 150)

30XWHPZE		301	401	451	551	601	651	801	901	1001	1101
Sound levels - unit with option 150											
Sound power level <sup>(1)</sup>	dB(A)	93	97	97	100	100	100	100	100	103	103
Sound pressure level at 1 m <sup>(2)</sup>	dB(A)	76	80	80	82	82	82	81	81	84	84
Sound levels - standard unit + option 257 <sup>(3)</sup>											
Sound power level <sup>(1)</sup>	dB(A)	-	94	94	98	98	98	97	97	101	101
Sound pressure level at 1 m <sup>(2)</sup>	dB(A)	-	76	76	80	80	80	78	78	82	82
Operating weight <sup>(4)</sup>	kg	2157	3050	3050	4102	4147	4175	6932	7010	7844	8182
Compressors											
Semi-hermetic 06T screw compressors, 50 r/s											
Circuit A	-	1	1	1	1	1	1	1	1	1	1
Circuit B	-	-	-	-	-	-	-	1	1	1	1
Refrigerant - unit with option 150											
R-1234ze											
Circuit A	kg	78	130	130	180	175	170	120	120	130	130
	teq CO <sub>2</sub>	0,5	0,9	0,9	1,3	1,2	1,2	0,8	0,8	0,9	0,9
Circuit B	kg	-	-	-	-	-	-	120	120	150	130
	teq CO <sub>2</sub>	-	-	-	-	-	-	0,8	0,8	1,1	0,9
Refrigerant - option 330											
R-515B											
Circuit A	kg	79	132	132	183	178	173	122	122	132	132
	teq CO <sub>2</sub>	23,1	38,7	38,7	53,6	52,2	50,7	35,7	35,7	38,7	38,7
Circuit B	kg	-	-	-	-	-	-	122	122	152	132
	teq CO <sub>2</sub>	-	-	-	-	-	-	35,7	35,7	44,5	38,7
Oil - unit with option 150											
HATCOL-4496											
Circuit A	l	20	20	20	25	25	25	20	20	25	25
Circuit B	l	-	-	-	-	-	-	20	20	20	25
Capacity control											
SmartVu™, electronic expansion valves (EXV)											
Minimum capacity	%	30	30	30	20	20	25	15	15	15	10
Evaporator											
Multi-pipe flooded type											
Water volume	l	61	101	101	154	154	154	293	293	321	321
Water connections (Victaulic)	in	5	6	6	8	8	8	8	8	8	8
Drain and vent connections (NPT)	in	3/8	3/8	3/8	3/8	3/8	3/8	3/8	3/8	3/8	3/8
Max. water-side operating pressure	kPa	1000	1000	1000	1000	1000	1000	1000	1000	1000	1000
Condenser											
Multi-pipe flooded type											
Water volume	l	55	103	103	148	148	148	316	316	340	340
Water connections (Victaulic)	in	5	6	6	8	8	8	8	8	10	10
Drain and vent connections (NPT)	in	3/8	3/8	3/8	3/8	3/8	3/8	3/8	3/8	3/8	3/8
Max. water-side operating pressure	kPa	1000	1000	1000	1000	1000	1000	1000	1000	1000	1000

(1) In dB ref=10<sup>-12</sup> W, (A) weighting. Declared dualnumber noise emission values in accordance with ISO 4871 (with an associated uncertainty of +/-3dB(A)). Measured in accordance with ISO 9614-1 and certified by Eurovent.

(2) In dB ref 20µPa, (A) weighting. Declared dualnumber noise emission values in accordance with ISO 4871 (with an associated uncertainty of +/-3dB(A)). For information, calculated from the sound power level Lw(A).

(3) Option 257 = Low noise level

(4) Weight shown is guideline only. Please refer to the unit nameplate

## ELECTRICAL DATA, UNITS FOR HIGH CONDENSING TEMPERATURES (OPTION 150)

30XW-PZE / 30XWHPZE		301	401	451	551	601	651	801	901	1001	1101
Power circuit											
Nominal power supply	V-ph-Hz	400-3-50									
Voltage range	V	360-440									
Control circuit		24 V via the built-in transformer									
Nominal start-up current <sup>(1)</sup>											
Circuit A	A	388	587	587	629	629	629	587	587	629	629
Circuit B	A	-	-	-	-	-	-	587	587	587	629
Option 81	A	-	-	-	-	-	-	712	725	767	815
Maximum start-up current <sup>(2)</sup>											
Circuit A	A	388	587	587	629	629	629	587	587	629	629
Circuit B	A	-	-	-	-	-	-	587	587	587	629
Option 81	A	-	-	-	-	-	-	833	860	902	972
Cosine phi nominal <sup>(3)</sup>		0,75	0,80	0,81	0,80	0,81	0,83	0,80	0,81	0,80	0,80
Cosine phi maximum <sup>(4)</sup>		0,90	0,90	0,90	0,89	0,89	0,89	0,90	0,90	0,89	0,89
Total harmonic distortion <sup>(4)</sup>	%	Closed to 0% (negligible)									
Maximum power input <sup>(5)</sup>											
Circuit A	kW	107	144	158	202	219	228	144	158	202	202
Circuit B	kW	-	-	-	-	-	-	144	158	158	202
Option 81	kW	-	-	-	-	-	-	288	317	360	404
Nominal current drawn <sup>(3)</sup>											
Circuit A	A	102	125	138	186	197	213	125	138	186	186
Circuit B	A	-	-	-	-	-	-	125	138	138	186
Option 81	A	-	-	-	-	-	-	250	276	324	372
Maximum current drawn (Un) <sup>(5)</sup>											
Circuit A	A	174	234	257	328	356	371	234	257	328	328
Circuit B	A	-	-	-	-	-	-	234	257	257	328
Option 81	A	-	-	-	-	-	-	468	514	585	656
Max. current drawn (Un -10%) <sup>(4)</sup>											
Circuit A	A	190	255	280	357	387	404	255	280	357	357
Circuit B	A	-	-	-	-	-	-	255	280	280	357
Option 81	A	-	-	-	-	-	-	510	560	637	714

(1) Instantaneous start-up current (maximum operating current of the smallest compressor(s) + locked rotor current or reduced start-up current of the largest compressor). Values obtained at standard Eurovent conditions: evaporator entering/leaving water temp. = 12°C/7°C, condenser entering/leaving water temp. = 30°C/35°C.

(2) Instantaneous start-up current (maximum operating current of the smallest compressor(s) + locked rotor current or reduced start-up current of the largest compressor). Values obtained at operation with maximum unit power input.

(3) Values obtained at standard Eurovent conditions: evaporator entering/leaving water temp. = 12°C/7°C, condenser entering/leaving water temp. = 30°C/35°C.

(4) Values obtained at operation with maximum unit power input.

(5) Values obtained at operation with maximum unit power input. Values given on the unit nameplate.



## DIMENSIONS/CLEARANCES

### 30XW-PZE/30XWHPZE 301-651

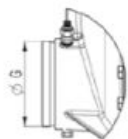
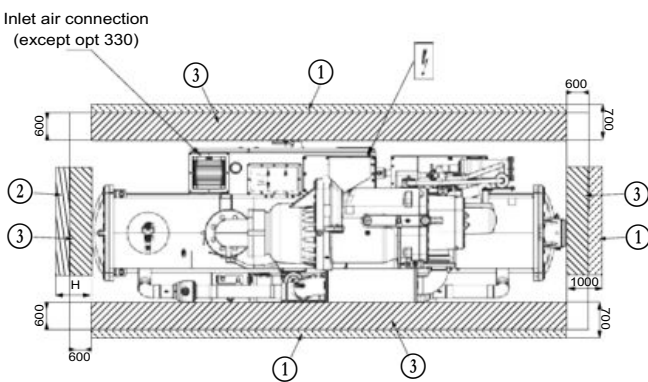
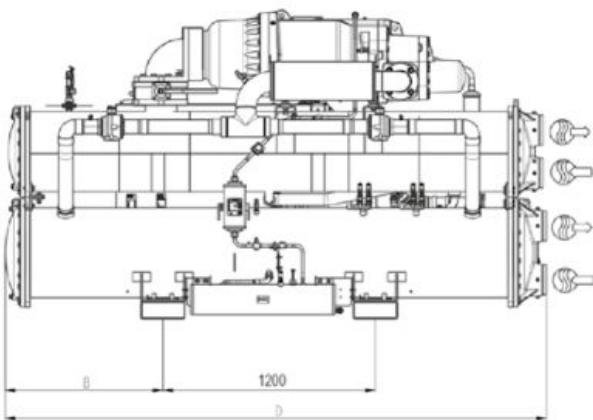
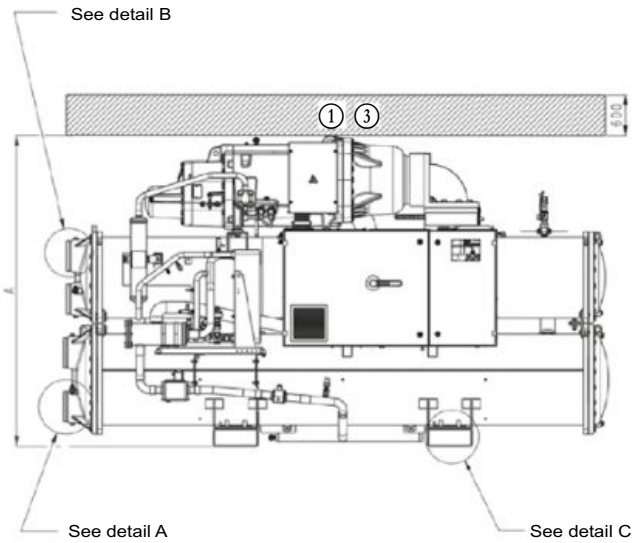

Detail A



Detail B



Detail C

Dimensions in mm								
	A	B	C	D	E	F	G	H
<b>30XW-PZE / 30XWHPZE</b>								
301	1612	800	982	2724	983	141,3	141,3	2600
401	1743	968	980	3059	982	168,3	168,3	2800
451	1743	968	980	3059	982	168,3	168,3	2800
551	1950	1083	1080	3290	1180	219,1	219,1	3100
601	1950	1083	1080	3290	1180	219,1	219,1	3100
651	1950	1083	1080	3290	1180	219,1	219,1	3100
<b>30XW-PZE / 30XWHPZE (option 150)</b>								
301	1612	800	982	2724	983	141,3	141,3	2600
401	1743	968	980	3059	982	168,3	168,3	2800
451	1743	968	1040	3059	1042	168,3	168,3	2800
551	1968	1083	1080	3290	1180	219,1	219,1	3100
601	1968	1083	1080	3290	1180	219,1	219,1	3100
651	1968	1083	1080	3290	1180	219,1	219,1	3100

#### Legend

All dimensions are given in mm

- ① Services clearances required
- ② Space required to remove cooler tubes
- ③ Zone ATEX
- Inlet water
- Outlet water
- Electrical supply entry

#### NOTES:

- Drawings are not contractually binding. Before designing an installation, consult the certified dimensional drawings supplied with the unit or available on request.
- For the positioning of the fixing points, weight distribution and centre of gravity coordinates please refer to the dimensional drawings.

**DIMENSIONS/CLEARANCES**

**30XW-PZE/30XWHPZE 801-1101**

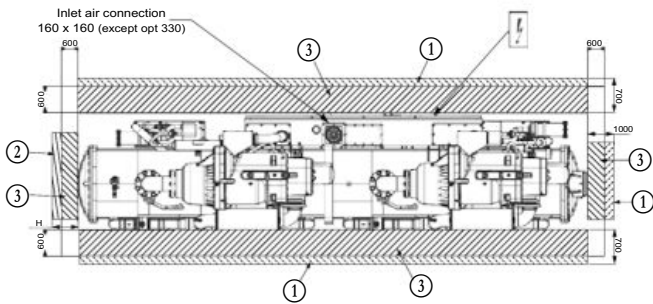
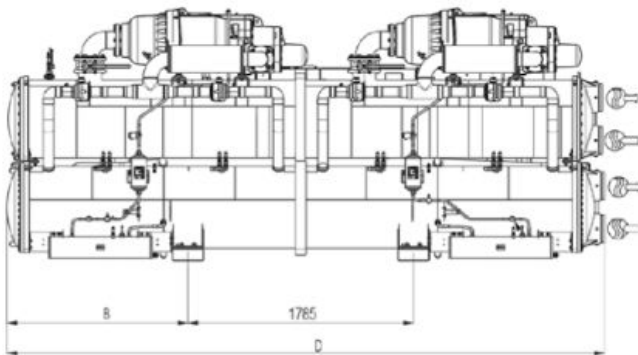
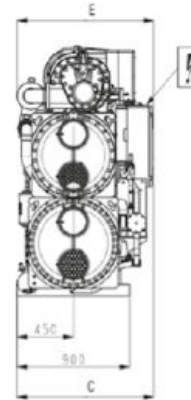
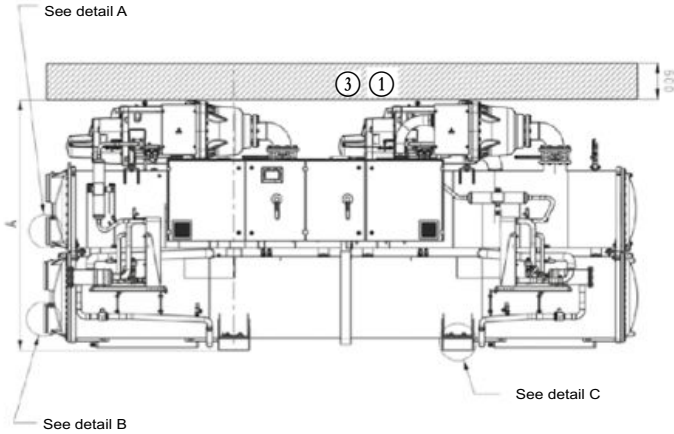

Dimensions in mm								
	A	B	C	D	E	F	G	H
<b>30XW-PZE / 30XWHPZE</b>								
<b>801</b>	1998	1512	1121	4730	1124	219,1	219,1	4500
<b>901</b>	1998	1512	1125	4730	1124	219,1	219,1	4500
<b>1001</b>	2051	1512	1238	4730	1238	219,1	219,1	4500
<b>1101</b>	2051	1512	1238	4730	1238	219,1	219,1	4500
<b>30XW-PZE / 30XWHPZE (option 150)</b>								
<b>801</b>	1998	1512	1121	4730	1124	219,1	219,1	4500
<b>901</b>	1998	1512	1125	4730	1124	219,1	219,1	4500
<b>1001</b>	2070	1512	1238	4730	1238	219,1	219,1	4500
<b>1101</b>	2051	1512	1238	4730	1238	219,1	219,1	4500

**Legend**

All dimensions are given in mm

- ① Services clearances required
- ② Space required to remove cooler tubes
- ③ Zone ATEX
- Inlet water
- Outlet water
- Electrical supply entry

**NOTES:**

- Drawings are not contractually binding. Before designing an installation, consult the certified dimensional drawings supplied with the unit or available on request.
- For the positioning of the fixing points, weight distribution and centre of gravity coordinates please refer to the dimensional drawings.

## WATER-SOURCED VARIABLE-SPEED SCREW HEAT PUMPS



- Low energy consumption
- High reliability
- Safe Design
- Easy and fast installation
- Minimised operating sound levels
- Environmental care
- Designed to support green building design

## 30XWHVZE-A



Nominal heating capacity 523-1555 kW  
Nominal cooling capacity 448-1312 kW

The 30XW-VZE/30XWHVZE water-sourced units are the premium solution for commercial and industrial applications where installers, consultants and building owners require maximum quality and optimal performances, especially at part load.

The 30XW-VZE/30XWHVZE units are designed to meet current and future requirements in terms of energy efficiency, versatility and compactness. They feature exclusive inverter-driven screw compressors - an evolution of the proven traditional Carrier twin-rotor screw compressor design. Other features include:

- The new SmartVu™ control
- Mechanically cleanable flooded heat exchangers
- Refrigerant R-1234ze or R-515B

The 30XW-VZE/30XWHVZE range is splitted into two versions:

- 30XW-VZE for air conditioning applications
- 30XWHVZE for heating applications

As standard, the unit can provide an evaporator leaving water temperature down to 3.3°C, and when operating as a heat pump, it can deliver up to 55°C on the condenser side.



CARRIER participates in the ECP programme for LCP-HP  
Check ongoing validity of certificate:  
[www.eurovent-certification.com](http://www.eurovent-certification.com)

\* Evaporator with aluminium jacket shown in the picture not standard - available as special order only

## CUSTOMER BENEFITS

### Low energy consumption

- The 30XW-VZE/30XWHVZE are designed for high performance both at full load and at part load.
  - Eurovent certified values per EN14511-3:2022: SEPR up to 10.7 and SEER up to 8.8
- High energy efficiency
  - Inverter-driven twin-rotor screw compressors allow precise capacity matching of building load changes and significantly reduce unit power input, especially at part-load.
  - Flooded multi-pipe heat exchangers for increased heat exchange efficiency.
  - Electronic expansion device permits operation at a lower condensing pressure and improved utilisation of the evaporator heat exchange surface.
- Optimised electrical performance
  - All 30XW-VZE/30XWHVZE units comply with class 3 of standard EN61800-3. Category C3 refers to industrial environments. With option 282 category C2 compliance is possible.
  - Inverter-driven motors ensure negligible start-up current (value is lower than the maximum unit current draw)

### High reliability

- The 30XW-VZE and 30XWHVZE ranges offer increased global performance as well as Carrier's acclaimed product quality and reliability. Major components are selected and tested to minimize failures possibility, as well as many design choices have been taken in this perspective.
- Inverter-driven screw compressors
  - Industrial-type screw compressors with oversized bearings and motor cooled by suction gas.
  - The inverter is optimised for each compressor motor to ensure reliable operation and easy maintenance.
  - All compressor components are easily accessible on site minimising down-time.
- Refrigerant circuits
  - Two independent refrigerant circuits (from 1000 kW upwards); the second one automatically takes over, if the first one develops a fault, maintaining partial cooling under all circumstances.
  - All components have been selected and tested with R-1234ze refrigerant and R-515B
- Evaporator
  - Electronic paddle-free flow switch. Auto-setting according to cooler size and fluid type.
- Auto-adaptive control
  - Control algorithm prevents excessive compressor cycling
  - Automatic compressor unloading in case of abnormally high condensing pressure or discharge temperature.
- Exceptional endurance tests
  - Partnerships with specialised laboratories and use of limit simulation tools (finite element calculation) for the design of critical components.
  - Transport simulation test in the laboratory on a vibrating table and then on an endurance circuit (based on a military standard)

### Safe Design

- Specific polyol ester oil qualified by Carrier for using with HFO-1234ze and R-515B to guarantee and maintain reliable bearing lubrication.
- Specific compressor gaskets compatible with HFO-1234ze and R-515B, tested and validated by Carrier.
- New relief valves designed for operation with HFO-1234ze and R-515B
- New control algorithms
- Specific documentation that contains all the installation, operation, maintenance and safety Instructions.
- No need of electrical cabinet ducted fresh air supply

### Easy and fast installation

- Compact design
  - The 30XW-VZE/30XWHVZE units are designed to offer compact dimensions for easy installation.
  - With a width of approximately 1.25 m up to 1000 kW the units can pass through standard door openings and only require minimum floor space in the plant room.
- Simplified electrical connections
  - Transformer supply to the integrated control circuit (400/24 V)
- Simplified water connections
  - Victaulic connections on the evaporator and condenser
  - Practical reference marks for entering and leaving water connections
  - Possibility to reverse the heat exchanger water inlet and outlet at the factory
  - Possibility to modify the number of heat exchanger passes
- Fast commissioning
  - Systematic factory operation test before shipment
  - Quick-test function for step-by-step verification of the instruments, expansion devices and compressors.
  - Non flammable use possible when selecting option 330, Low GWP A1 R-515B Refrigerant

### Minimised operating sound levels

- The inverter technology used for the compressor motors minimises noise levels at part load operation. In two-compressor units at 25% of the maximum load the unit sound power level is reduced by 10 dB(A).
- Standard unit features include:
  - Silencers on the compressor discharge line.
  - Sound insulation on the components that are most subjected to radiated noise.
- Option 257 further reduces the global unit sound level.



## CUSTOMER BENEFITS

### Environmental care



- R-1234ze long-term refrigerant solution
  - HFO refrigerant with nearly zero global warming potential (GWP < 1) and zero ozone depletion potential (ODP = 0).
  - Not impacted by the HFC phase-down plan in Europe (79% HFC reduction in EU member states at 2030 horizon)
  - Compliant with refrigerant regulation in Switzerland that bans the use of HFC refrigerant in large capacity air-conditioning equipment.
- Leak-tight refrigerant circuit
  - Reduction of leaks as no capillary tubes and flare connections are used
  - Verification of pressure transducers and temperature sensors without transferring refrigerant charge
  - Discharge line shut-off valve and liquid line service valve for simplified maintenance.

### Designed to support green building design

- A green building is a building that is environmentally sustainable and has been designed, constructed and is operated to minimise the total impact on the environment. The underlying principles of this approach: The resulting building will be economical to operate, offer increased comfort and create a healthier environment for the people who live and work there, increasing productivity.
- The air conditioning system can use between 30 and 40% of the annual building energy consumption. Selection of the right air conditioning system is one of the main aspects to consider when designing a green building. For buildings with a variable load throughout the year 30XW-VZE/30XWHVZE units offers a solution to this important challenge.
- A number of green building certification programs exist in the market and offer third-party assessment of green building measures for a wide variety of building types.
- The following example looks at how Carrier's new 30XW-VZE/30XWHVZE range helps customers involved in LEED® building certification.

#### 30XW-VZE/30XWHVZE and LEED® certification

The LEED® (Leadership in Energy and Environmental Design) green building certification programme is a pre-eminent programme to rate the design, construction and operation of green buildings with points assigned in seven credit categories:

- Sustainable Sites (SS)
- Water Efficiency (WE)
- Energy & Atmosphere (EA)
- Materials & Resources (MR)
- Indoor Environmental Quality (IEQ)
- Innovation in Design (ID)
- Regional Priority (RP).

There are a number of different LEED® products.

While the strategies and categories assessed remain same, the point distribution varies to address different building types and application needs, for example according to New Construction, Schools, Core & Shell, Retail and Healthcare.

All programmes now use the same point scale:

#### 110 Possible LEED® points

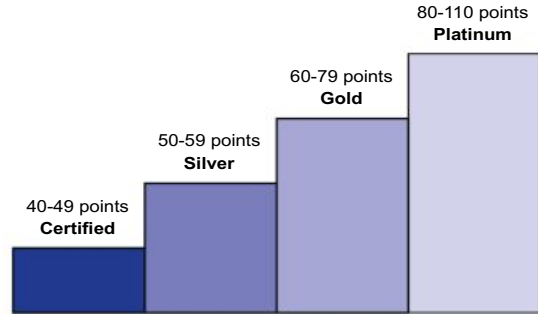

The majority of credits in LEED® rating systems are performance-based and achieving them is dependent on the impacts of each component or sub-system to the overall building.

While the LEED® green building certification programs do not certify products or services, the selection of the right products, systems or service programs is critical to obtain LEED® certification for a registered project, because the right products or service programmes can help meet the goals of green construction and ongoing operation and maintenance.

The choice of heating, ventilating and air conditioning (HVAC) products in particular can have a significant impact on LEED® certification, as the HVAC system directly impacts two categories that together influence 40% of the available points.

#### Overview of LEED® for new construction and major renovations

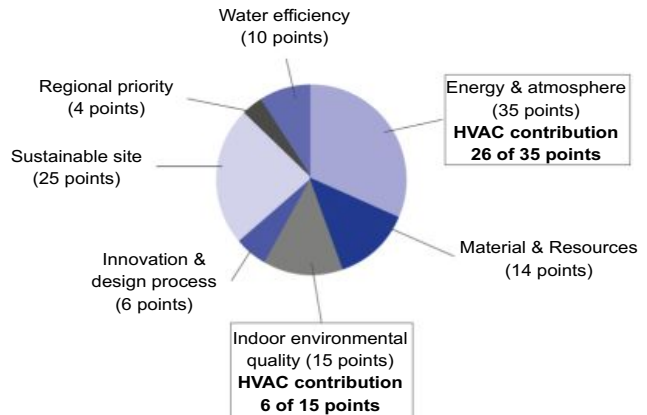

The new 30XW-VZE/30XWHVZE units from Carrier can assist building owners to earn LEED® points in particular in the Energy & Atmosphere (EA) credit category and help address the following prerequisites and credit requirements:

- **EA prerequisite 2: Minimum energy Performance**  
The 30XW-VZE/30XWHVZE exceeds the energy efficiency requirements of ASHRAE 90,1-2007; therefore it complies with the prerequisite standard.
- **EA prerequisite 3: Fundamental Refrigerant Management**  
The 30XW-VZE/30XWHVZE does not use chlorofluorocarbon (CFC) refrigerants thus satisfying the prerequisite statement.



## CUSTOMER BENEFITS

- **EA credit 1: Optimise energy performance (1 to 19 points)**  
Points for this credit are assigned depending on the energy cost reduction virtually achievable by the new building, compared to ASHRAE 90,1-2007 reference. The 30XW-VZE/30XWHVZE, which is designed for high performance especially during part load operation, contributes reducing the energy consumption of the building and therefore helps gaining points within this credit. In addition, the Carrier HAP (Hourly Analyses Program) can be used as an energy analyses program complying with the modeling requirements for this credit and produce reports that are easily transferable to LEED® templates.
- **EA credit 4: Enhanced refrigerant management (2 points)**  
With this credit, LEED® awards systems that minimise the Ozone Depletion Potential (ODP) and Global Warming Potential (GWP) of the system. The 30XW-VZE/30XWHVZE uses HFO-1234ze refrigerant with Global Warming Potential Index below 1 and therefore contributes toward satisfying this credit under LEED®.

**NOTE: This section describes the prerequisites and credit requirements in LEED® for New Construction and is directly related to the 30XW-V-ZE/30XWHV-ZE. Other prerequisites and credit requirements are not directly and purely related to the air-conditioning unit itself, but more to the control of the complete HVAC system.**

i-Vu®, Carrier's open control system, has features that can be valuable for:

- EA prerequisite 1: Fundamental commissioning of energy management system
- EA credit 3: Enhanced commissioning (2 points)
- EA credit 5: Measurements and verification (3 points).

**NOTE: Products are not reviewed or certified under LEED®. LEED® credit requirements cover the performance of materials in aggregate, not the performance of individual products or brands. For more information on LEED®, visit [www.usgbc.org](http://www.usgbc.org).**

## TECHNICAL INSIGHTS

### SmartVu™

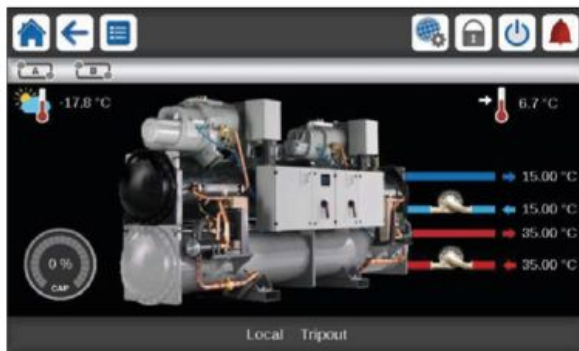

- New innovative smart control features :
  - An intuitive and user-friendly, coloured, 7" interface
  - 1 languages available on choice :DE, EN, ES,FR,T,NL PT, TR, TU + one additional customer choice
  - Screen-shots with concise and clear information in local languages
  - Complete menu, customised for different users (end user, service personnel and Carrier-factory technicians)
  - Setpoint offset based on the outside air temperature
  - Safe operation and unit setting: Password protection ensures that unauthorised people cannot modify any advanced parameters
  - Simple and "smart" intelligence uses data collection from the constant monitoring of all machine parameters to optimise unit operation
  - Night-mode: Cooling capacity management for reduced Noise level.
  - With hydraulic module: Water pressure display and water flow rate calculation.
- Energy management :
  - Internal time schedule clock controls chiller on/off times and operation at a second set-point
  - The DCT (Data Collection Tool) records the alarms history to simplify and facilitate service operations.
- Maintenance functions :
  - F-Gas regulation leak check reminder alert
  - Maintenance alert can be configured to days, months or hours of operation

- Advanced communication features :
  - Easy and high-speed communication technology over Ethernet (IP) to a centralised building management system
  - Access to multiple unit parameters.

### Remote Management (Standard)

- Units with SmartVu™ control can be easily accessed from the internet, using a PC with an Ethernet connection. This makes remote control quick and easy and offers significant advantages for service operations
- Aquaforce with Greenspeed® Intelligence is equipped with an RS485 serial port that offers multiple remote control, monitoring and diagnostic possibilities. When networked with other Carrier equipment through the CCN (Carrier Comfort Network - proprietary protocol), all components form a HVAC system fully-integrated and balanced through one of the Carrier's network system products, like the Chiller System anager or the Plant System anager (optional).
- The chiller also communicates with other building management systems via optional communication gateways (BACnet, LON or JBus).
- The following commands/visualisations are possible from remote connection:
  - Start/Stop of the machine
  - Dual set-point management: Through a dedicated contact is possible to activate a second set-point (example, unoccupied mode)
  - Demand limit setting: To limit the maximum chiller capacity to a predefined value
  - Water pump control: These outputs control the contactors of one/two evaporator water pumps.
  - Water pumps changeover (only with hydraulic module options): These contacts are used to detect a water pump operation fault and automatically change over to the other pump.
  - Operation visualisation: indication if the unit is operating or if it is in stand-by (no cooling load)
  - Alarm visualisation.

## TECHNICAL INSIGHTS

### Remote management (EMM option)

- The Energy management module (EMM) offers extended remote control possibilities:
- Room temperature: Permits set-point reset based on the building indoor air temperature (if Carrier thermostats are installed)
- Set-point reset: Allows reset of the cooling set-point based on a 4-20 mA or 0-10 V signal
- Demand limit: Permits limitation of the maximum chiller capacity based on 0-10 V signal
- Demand limit 1 and 2: Closing of these contacts limits the maximum chiller capacity to two predefined values.
- User safety: This contact can be used for any customer safety loop; opening the contact generates a specific alarm.
- Ice storage end: When ice storage has finished, this input permits return to the second set-point (unoccupied mode).
- Time schedule override: Closing of this contact cancels the programmed time schedule.
- Out of service: This signal indicates that the chiller is completely out of service.
- Chiller capacity: This analogue output (0-10 V) gives an immediate indication of the chiller capacity.
- Alert indication: This volt-free contact indicates the necessity to carry out a maintenance operation or the presence of a minor fault.
- Compressors running status: Set of outputs (as many as the compressors number) indicating which compressors are running.

- Chiller capacity: this analogue output (0-10 V) gives an immediate indication of the chiller capacity
- Alert indication: this volt-free contact indicates the necessity to carry out a maintenance operation or the presence of a minor fault.
- Compressors running status : set of outputs (as many as the compressors number) indicating which compressors are running.

### New inverter-driven Thunderbolt screw compressor

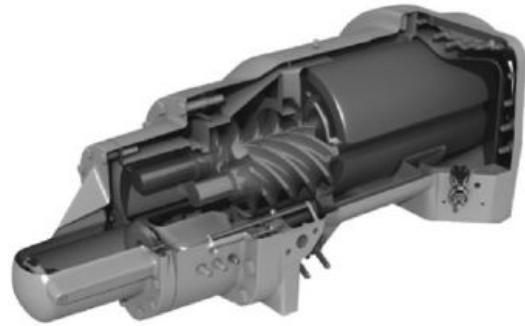

- The Carrier 06T screw compressor designed for operation with HFO-1234ze refrigerant benefits from Carrier's long experience in the development of twin-rotor screw compressors. The design of the Thunderbolt compressors is based on the successful 06T screw compressor, core of the well-known Aquaforce series.
- Advanced control algorithms combine inverter frequency output with motor input logic to minimise mechanical part stress, resulting in best compression performance and high chiller reliability. The compressor is equipped with bearings with oversized rollers, oil pressure lubricated for reliable and durable operation, even at maximum load.
- Screw compressors use positive displacement principle to compress gases at higher pressure. As a result, in case of exceptional high temperature condenser side (due for example to water-pipes fouling or operation in harsh climate with an external dry cooler) the compressor does not switch off, but continues operation at reduced capacity (unloaded mode).
- The silencer in the discharge line considerably reduces discharge gas pulsations for much quieter operation.
- The condenser includes an oil separator that minimises the amount of oil in circulation in the refrigerant circuit and re-directs it to the compressor function.

### Remote management (EMM option)

The Energy Management Module offers extended remote control possibilities:

- Room temperature: permits set-point reset based on the building indoor air temperature (with Carrier thermostat)
- Set point reset: ensures reset of the cooling set-point based on a 0-10 V signal
- Demand limit: permits limitation of the maximum chiller power or current based on a 0-10 V signal
- Demand limit 1 and 2: closing of these contacts limits the maximum chiller power or current to two predefined values
- User safety: this contact can be used for any customer safety loop; opening the contact generates a specific alarm
- Ice storage end: when ice storage has finished, this input permits return to the second set-point (unoccupied mode)
- Time schedule override: closing of this contact cancels the time schedule effects
- Out of service: this signal indicates that the chiller is completely out of service

### Digit number

1	2	3	4	5	6	7	8	9	10	11	12	13	14	15	16	17	18
3	0	X	W	-	V	Z	E	0	3	0	1	B	0	0	0	1	-

#### Legend :

- Digit 1 to 4: Water-cooled chiller with screw compressor
- Digit 5: Application type, - = Cooling, H = Heating
- Digit 6: Efficiency, V = Variable
- Digit 7 & 8: Unit using R1234ze refrigerant
- Digit 9 to 12: Model number based on cooling capacity in kW
- Digit 13: index For major product modification (visible impact for customer)
- Digit 14 to 17: Counter used to generate a one time product code
- Digit 18: Not used

## OPTIONS

Options	N°	Description	Advantages	Use
Light-brine solution, down to -3°C	8	Implementation of new algorithms of control to allow chilled brine solution production down to -3°C when ethylene glycol is used (0°C with propylene glycol)	Matches with most application requirements for ground-sourced heat pumps and fits with many industrial processes requirements	451-1301 (see dedicated paragraph)
Master/slave operation	58	Unit equipped with supplementary water outlet temperature sensor kit to be field-installed allowing master/slave operation of two units connected in parallel	Optimised operation of two units connected in parrallele operation with operating time equalisation	451-1301
Condenser insulation	86	Thermal condenser insulation	Minimizes thermal dispersions condenser side (key option for heat pump or heat recovery applications) and allows compliancy with special installation criteria (hot parts insulated)	451-1301
Service valve set	92	Liquid line valve (evaporator inlet) and compressor suction line valve	Allow isolation of various refrigerant circuit components for simplified service and maintenance	451-1301
Evaporator with one pass less	100C	Evaporator with one pass on the water side. Evaporator inlet and outlet on opposite sides.	Easy to install, depending on site. Reduced pressure drops	451-1301
Condenser with one pass less	102C	Condenser with one pass on the water side. Condenser inlet and outlet on opposite sides.	Easy to install, depending on site. Reduced pressure drops	451-1301
21 bar evaporator	104	Reinforced evaporator for extension of the maximum water-side service pressure to 21 bar (standard 10 bar)	Covers applications with a high water column evaporator side (typically high buildings)	451-1301
21 bar condenser	104A	Reinforced condenser for extension of the maximum water-side service pressure to 21 bar (standard 10 bar)	Covers applications with a high water column condenser side (typically high buildings)	451-1301
Reversed evaporator water connections	107	Evaporator with reversed water inlet/outlet	Easy installation on sites with specific requirements	451-1301
Reversed condenser water connections	107A	Condenser with reversed water inlet/outlet	Easy installation on sites with specific requirements	451-1301
Lon gateway	148D	Two-directional communication board complying with Lon Talk protocol	Connects the unit by communication bus to a building management system	451-1301
Bacnet over IP	149	Two-directional high-speed communication using BACnet protocol over Ethernet network (IP)	Easy and high-speed connection by ethernet line to a building management system. Allows access to multiple unit parameters	451-1301
Modbus over IP and RS485	149B	Bi-directional high-speed communication using Modbus protocol over Ethernet network (IP)	Easy and high-speed connection by ethernet line to a building management system. Allows access to multiple unit parameters	451-1301
Condensing temperature limitation	150B	Limitation of the maximum condenser leaving water temperature to 45°C	Reduced maximum power input and current absorption: power cables and protection elements can therefore be downsized	451-1301
Control for low cond. temperature systems	152	Output signal (0-10 V) to control the condenser water inlet valve	Simple installation: for applications with cold water at condenser inlet (ex. ground-source, groundwater-source, superficial water-source applications) the signal permits to control a 2 or 3-way valve to maintain condenser water temperature (and so condensing pressure) at acceptable values	451-1301
Energy Management Module	156	EMM Control board with additional inputs/ outputs. See Energy Management Module option chapter	Extended remote control capabilities (Set-point reset, ice storage end, demand limits, boiler on/off command...)	451-1301
Input contact for Refrigerant leak detection	159	0-10 V signal to report any refrigerant leakage in the unit directly on the controller (the leak detector itself must be supplied by the customer)	Immediate customer notification of refrigerant losses to the atmosphere, allowing timely corrective actions	451-1301
Dual relief valves on 3-way valve	194	Three-way valve upstream of dual relief valves on the shell and tubes evaporator	Valve replacement and inspection facilitated without refrigerant loss. Comforms to European standard EN378/BGVD4	451-1301
Compliance with Swiss regulations	197	Additional tests on the water heat exchangers: supply (additional of PED documents) supplementary certificates and test certifications	Conformance with Swiss regulations	451-1301

## OPTIONS

Options	N°	Description	Advantages	Use
Compliance with Russian regulations	199	EAC certification	Conformance with Russian regulations	451-1301
Compliance with Australian regulations	200	Unit approved to Australian code	Conformance with Australian regulations	451-1301
Low noise level	257	Evaporator sound insulation	3 dB(A) quieter than standard unit	451-1301
Welded evaporator connection kit	266	Victaulic piping connections with welded joints	Easy installation	451-1301
Welded condenser water connection kit	267	Victaulic piping connections with welded joints	Easy installation	451-1301
Flanged evaporator water connection kit	268	Victaulic piping connections with flanged joints	Easy installation	451-1301
Flanged condenser water connection kit	269	Victaulic piping connections with flanged joints	Easy installation	451-1301
Thermal compressor insulation	271	The compressor is covered with a thermal insulation layer	Prevents air humidity to condensate on the compressor surface	451-1301
EMC classification C2, as per EN 61800-3	282	Additional RFI filters on the unit power line	Reduces electromagnetic interferences for compliance with emission level category C2 in order to allow the units to operate in the first environment (so called, residential environment)	451-1301
Fast Capacity Recovery	295	New software algorithms to allow quick restart and fast loading while preserving unit-reliability	Full capacity recovery in approximately 6 minutes after power failure. Matches requirements of typical critical missions application	451-1301
Compliance with Morocco regulation	327	Specifics documents according Morocco regulation	Conformance with Morocco regulations	451-1301
Low GWP A1 R-515B refrigerant	330	Unit delivered with R-515B refrigerant charge (A1, GWP 299)		451-1301



PHYSICAL DATA, 30XW-VZE UNITS

30XW-V ZE / 30XWHVZE				451	501	601	651	851	1001	1101	1201	1301
<b>Heating</b>												
<b>Standard unit</b> Full load performances*	HW1	Nominal capacity	kW	523	581	730	780	1017	1157	1304	1450	1555
		COP	kW/kW	6,3	6,14	6,04	5,92	6,27	6,29	6,12	5,74	5,61
	HW2	Nominal capacity	kW	491	544	677	730	955	1081	1211	1344	1452
		COP	kW/kW	4,74	4,6	4,55	4,39	4,73	4,73	4,67	4,42	4,28
	HW3	Nominal capacity	kW	466	508	628	689	906	1007	1122	1242	1367
		COP	kW/kW	3,52	3,41	3,42	3,24	3,51	3,5	3,52	3,39	3,22
<b>Standard unit</b> Seasonal energy efficiency **	HW1	SCOP <sub>30/35°C</sub>	kWh/kWh	7,64	7,39	7,62	7,57	7,45	7,4	7,17	6,64	6,56
		ηs heat <sub>30/35°C</sub>	%	298	288	297	295	290	288	279	257	254
		SCOP <sub>47/55°C</sub>	kWh/kWh	5,34	5,3	5,26	5,21	5,31	5,39	5,46	5,17	5,11
	HW3	ηs heat <sub>47/55°C</sub>	%	206	204	202	201	204	207	210	199	197
		P <sub>rated</sub>	kW	559	614	761	827	1086	1217	1361	1507	1645
<b>Cooling</b>												
<b>Standard unit</b> Full load performances*	CW1	Nominal capacity	kW	448	496	620	660	870	991	1115	1227	1312
		EER	kW/kW	5,53	5,39	5,26	5,14	5,57	5,6	5,47	5,14	5,05
	CW2	Nominal capacity	kW	670	728	915	970	1301	1455	1296	1423	1521
		EER	kW/kW	7,88	7,49	7,26	7,14	7,9	7,74	6,19	5,76	5,7
<b>Standard unit</b> Seasonal energy efficiency **	<b>SEER<sub>12/7°C</sub> Comfort low temp.</b>		<b>kWh/kWh</b>	<b>8,12</b>	<b>8,15</b>	<b>8,77</b>	<b>8,37</b>	<b>8,41</b>	<b>8,48</b>	<b>7,48</b>	<b>7,33</b>	<b>7,13</b>
	<b>ηs cool<sub>12/7°C</sub></b>		<b>%</b>	<b>322</b>	<b>323</b>	<b>348</b>	<b>332</b>	<b>333</b>	<b>336</b>	<b>296</b>	<b>290</b>	<b>282</b>
	<b>SEPR<sub>12/7°C</sub> Process high temp.</b>		<b>kWh/kWh</b>	<b>10,49</b>	<b>10,23</b>	<b>10,42</b>	<b>10,03</b>	<b>10,71</b>	<b>10,71</b>	<b>9,66</b>	<b>9,12</b>	<b>9,10</b>
<b>Sound levels - standard unit</b>												
		Sound power level <sup>(1)</sup>	dB(A)	103	103	103	103	104	104	104	104	104
		Sound pressure level at 1 m <sup>(2)</sup>	dB(A)	85	85	85	85	85	85	85	85	85
<b>Sound levels - standard unit + option 257<sup>(3)</sup></b>												
		Sound power level <sup>(1)</sup>	dB(A)	100	100	100	100	101	101	101	101	101
		Sound pressure level at 1 m <sup>(2)</sup>	dB(A)	82	82	82	82	82	82	82	82	82
<b>Dimensions - standard unit</b>												
		Length	mm	3059	3059	3290	3290	4730	4730	4730	4730	4730
		Width	mm	1087	1087	1237	1237	1164	1164	1264	1264	1264
		Height	mm	1743	1743	1948	1948	1997	1997	2051	2051	2051

\* In accordance with standard EN14511-3:2022  
 \*\* In accordance with standard EN14825:2022, average climate  
 HW1 Heating mode conditions: Evaporator entering/leaving water temperature 10°C/7°C, condenser entering/leaving water temperature 30°C/35°C, evaporator and condenser fouling factor 0 m². kW  
 HW2 Heating mode conditions: Evaporator entering/leaving water temperature 10°C/7°C, condenser entering/leaving water temperature 40°C/45°C, evaporator and condenser fouling factor 0 m². kW  
 HW3 Heating mode conditions: Evaporator entering/leaving water temperature 10°C/7°C, condenser entering/leaving water temperature 47°C/55°C, evaporator and condenser fouling factor 0 m². kW  
 CW1 Cooling mode conditions: Evaporator water entering/leaving temperature 12°C/7°C, condenser entering/leaving water temperature 30°C/35°C, evaporator and condenser fouling factor 0 m².K/W  
 CW2 Cooling mode conditions: Evaporator water entering/leaving temperature 23°C/18°C, condenser entering/leaving water temperature 30°C/35°C, evaporator and condenser fouling factor 0 m².K/W  
 ηs heat<sub>30/35°C</sub> & SCOP<sub>30/35°C</sub> Values calculated in accordance with EN14825:2022  
 ηs heat<sub>47/55°C</sub> & SCOP<sub>47/55°C</sub> Values calculated in accordance with EN14825:2022  
 ηs cool<sub>12/7°C</sub> & SEER<sub>12/7°C</sub> **Bold values compliant to Ecodesign regulation: (EU) No 2016/2281 for Comfort application**  
 SEPR<sub>12/7°C</sub> **Bold values compliant to Ecodesign regulation: (EU) No 2016/2281 for Process application**  
 (1) In dB ref=10<sup>-12</sup> W, (A) weighting. Declared dualnumber noise emission values in accordance with ISO 4871 (with an associated uncertainty of +/-3dB(A)). Measured in accordance with ISO 9614-1 and certified by Eurovent.3dB(A)). Measured in accordance with ISO 9614-1 and certified by Eurovent.  
 (2) in dB ref 20μPa, (A) weighting. Declared dualnumber noise emission values in accordance with ISO 4871 (with an associated uncertainty of +/-3dB(A)). For information, calculated from the sound power level Lw(A).  
 (3) Option 257 = Low noise level  
 (4) Weight shown is guideline only. To find out the unit refrigerant charge, please refer to the unit nameplate



Eurovent certified values



## PHYSICAL DATA, 30XW-VZE UNITS

30XW-V ZE / 30XWHVZE		451	501	601	651	851	1001	1101	1201	1301
<b>Operating weight<sup>(4)</sup></b>	kg	3223	3261	4263	4267	7477	7553	7731	7932	7970
<b>Compressors</b>		Semi-hermetic 06T screw compressors, 60 r/s								
Circuit A	-	1	1	1	1	1	1	1	1	1
Circuit B	-	-	-	-	-	1	1	1	1	1
<b>Oil - standard unit</b>		HATCOL-4496								
Circuit A	l	20	20	25	25	20	20	25	25	25
Circuit B	l	-	-	-	-	20	20	20	25	25
<b>Refrigerant - standard unit</b>		R1234ze (E)								
Circuit A	kg	130	130	180	175	120	120	115	115	110
	teq CO <sub>2</sub>	0,9	0,9	1,3	1,2	0,8	0,8	0,8	0,8	0,8
Circuit B	kg	-	-	-	-	120	120	120	115	110
	teq CO <sub>2</sub>	-	-	-	-	0,8	0,8	0,8	0,8	0,8
<b>Refrigerant - option 330</b>		R515B								
Circuit A	kg	132	132	183	178	122	122	117	117	112
	teq CO <sub>2</sub>	38,7	38,7	53,6	52,2	35,7	35,7	34,3	34,3	32,8
Circuit B	kg	-	-	-	-	122	122	122	117	112
	teq CO <sub>2</sub>	-	-	-	-	35,7	35,7	35,7	34,3	32,8
<b>Capacity control</b>		SmartVu™, inverter-driven compressor, electronic expansion valve (EXV)								
Minimum capacity	%	30	30	15	15	30	30	15	15	15
<b>Evaporator</b>		Multi-pipe flooded type								
Water volume	l	106	106	154	154	297	297	297	297	297
Water connections (Victaulic)	in	6	6	8	8	8	8	8	8	8
Drain and vent connections (NPT)	in	3/8	3/8	3/8	3/8	3/8	3/8	3/8	3/8	3/8
Max. water-side operating pressure	kPa	1000	1000	1000	1000	1000	1000	1000	1000	1000
<b>Condenser</b>		Multi-pipe flooded type								
Water volume	l	112	112	165	165	340	340	340	340	340
Water connections (Victaulic)	in	6	6	8	8	8	8	8	8	8
Drain and vent connections (NPT)	in	3/8	3/8	3/8	3/8	3/8	3/8	3/8	3/8	3/8
Max. water-side operating pressure	kPa	1000	1000	1000	1000	1000	1000	1000	1000	1000

(4) Weight shown is guideline only. To find out the unit refrigerant charge, please refer to the unit nameplate

## ELECTRICAL DATA

30XW-VZE /30XWHVZE		451	501	601	651	851	1001	1101	1201	1301
<b>Power circuit</b>										
Nominal power supply	V-ph-Hz	400-3-50								
Voltage range	V	360-440								
<b>Control circuit</b>										
24 V via the built-in transformer										
<b>Start-up current<sup>(1)</sup></b>	A	Negligible (lower than maximum current drawn)								
<b>Maximum power factor<sup>(2)</sup></b>		0,91-0,93	0,91-0,93	0,91-0,93	0,91-0,93	0,91-0,93	0,91-0,93	0,91-0,93	0,91-0,93	0,91-0,93
<b>Cosine phi</b>		> 0,98	> 0,98	> 0,98	> 0,98	> 0,98	> 0,98	> 0,98	> 0,98	> 0,98
<b>Harmonic distortion rate<sup>(3)</sup></b>	%	35-45	35-45	35-45	35-45	35-45	35-45	35-45	35-45	35-45
<b>Maximum power input<sup>(4)</sup></b>										
Circuit A	kW	135	157	189	208	135	157	189	189	208
Circuit B	kW	-	-	-	-	135	157	157	189	208
With option 81	kW	-	-	-	-	270	314	346	378	416
<b>Eurovent current draw*</b>										
Circuit A	A	129	148	180	197	129	149	180	180	197
Circuit B	A	-	-	-	-	129	149	149	180	197
With option 81	A	-	-	-	-	258	298	329	360	394
<b>Maximum current draw (Un)<sup>(4)</sup></b>										
Circuit A	A	195	245	295	325	195	245	295	295	325
Circuit B	A	-	-	-	-	195	245	245	295	325
With option 81	A	-	-	-	-	390	490	540	590	650
<b>Maximum current draw (Un -10%)<sup>(3)</sup></b>										
Circuit A	A	206	260	313	345	206	260	313	313	345
Circuit B	A	-	-	-	-	206	260	260	313	345
With option 81	A	-	-	-	-	412	520	573	626	690
<b>Maximum power input with option 150B<sup>(4)</sup></b>										
Circuit A	kW	106	134	161	177	106	134	161	161	177
Circuit B	kW	-	-	-	-	106	134	134	161	177
With option 81	kW	-	-	-	-	212	268	295	322	354
<b>Maximum current draw (Un) with option 150B<sup>(4)</sup></b>										
Circuit A	A	169	213	257	283	169	213	257	257	283
Circuit B	A	-	-	-	-	169	213	213	257	283
With option 81	A	-	-	-	-	338	426	470	514	566
<b>Dissipated power<sup>(3)</sup></b>	W	3000	4200	4700	5300	6000	8400	8900	9400	10600

(1) Instantaneous start-up current.

(2) May vary, based on the short-circuit current/max. current draw ratio of the system transformer. Values obtained at operation with maximum unit power input.

(3) Values obtained at operation with maximum unit power input.

(4) Values obtained at operation with maximum unit power input. Values given on the unit name plate.

\* Eurovent unit operating conditions: evaporator entering/leaving water temperature = 12°C/7°C, condenser entering/leaving water temperature = 30°C/35°C. Gross performances, not in accordance with EN14511-3:2022. These performances do not take into account the correction for the proportional heating capacity and power input generated by the water pump to overcome the internal pressure drop in the heat exchanger.

## DIMENSIONS/CLEARANCES

### 30XW-VZE/30XWHVZE 451-651

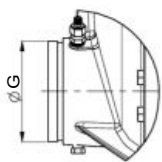
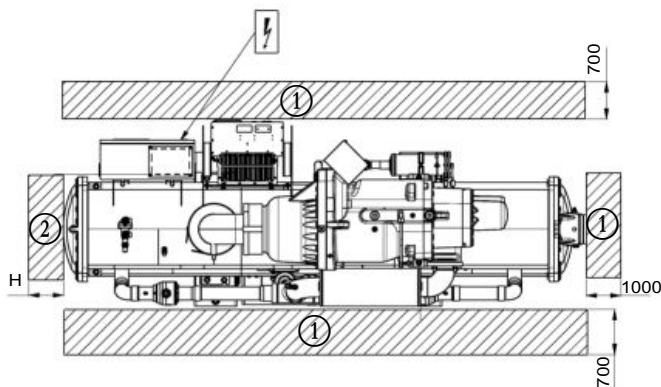
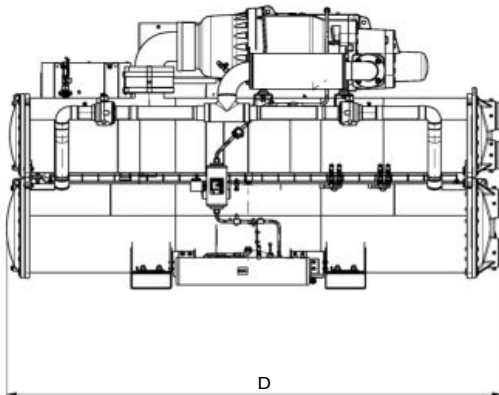
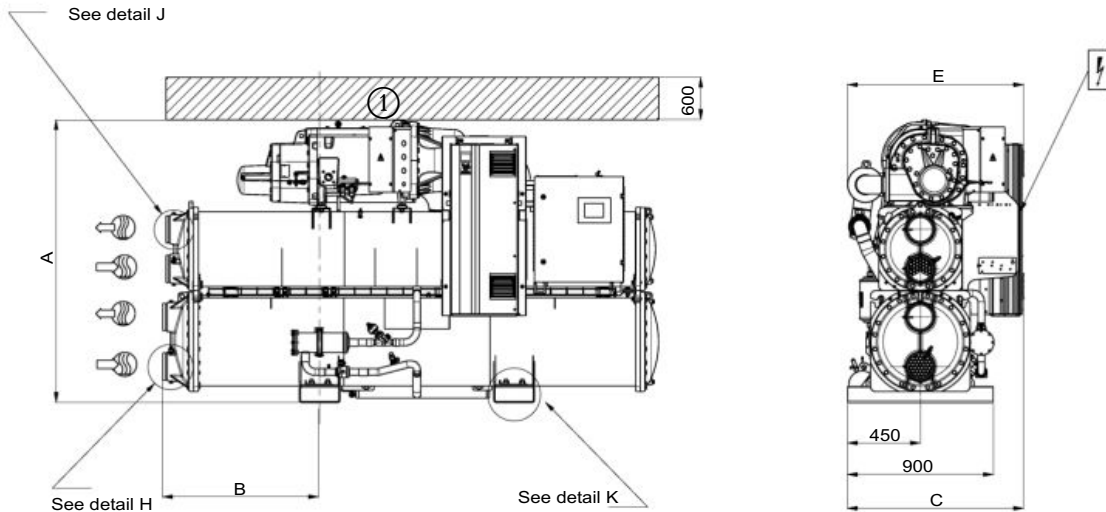

Detail H

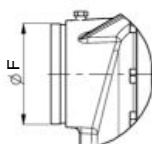

Detail J

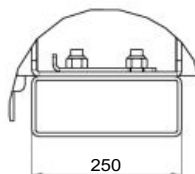

Detail K

Dimensions in mm

	A	B	C	D	E	F	G	H
<b>30XW-VZE/30XWHVZE</b>								
<b>451</b>	1743	968	1087	3059	1086	168,3	168,3	2800
<b>501</b>	1743	968	1087	3059	1086	168,3	168,3	2800
<b>601</b>	1948	1083	1137	3290	1237	219,1	219,1	3100
<b>651</b>	1948	1083	1137	3290	1237	219,1	219,1	3100

**Legend**

All dimensions are given in mm

- Services clearances required
- Space required to remove
- Inlet water
- Outlet water
- Electrical supply entry

**NOTES:**

Drawings are not contractually binding. Before designing an installation, consult the certified dimensional drawings supplied with the unit or available on request.

For the positioning of the fixing points, weight distribution and centre of gravity coordinates please refer to the dimensional drawings.

## DIMENSIONS/CLEARANCES

### 30XW-VZE/30XWHVZE 851-1301

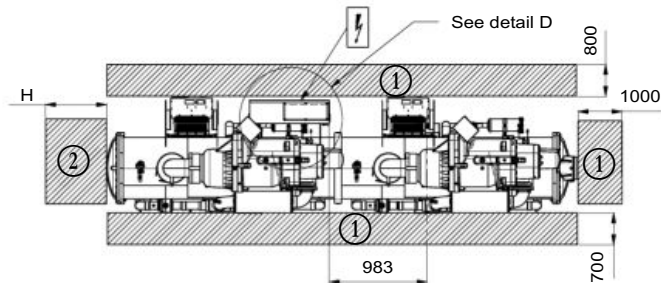
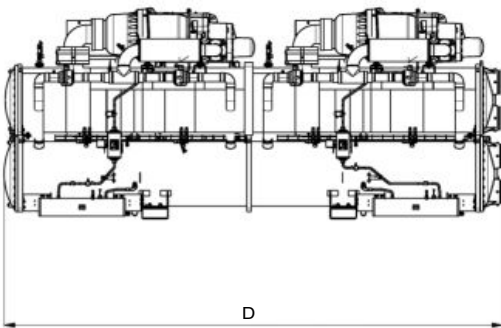
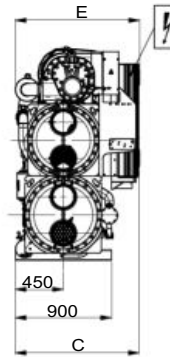
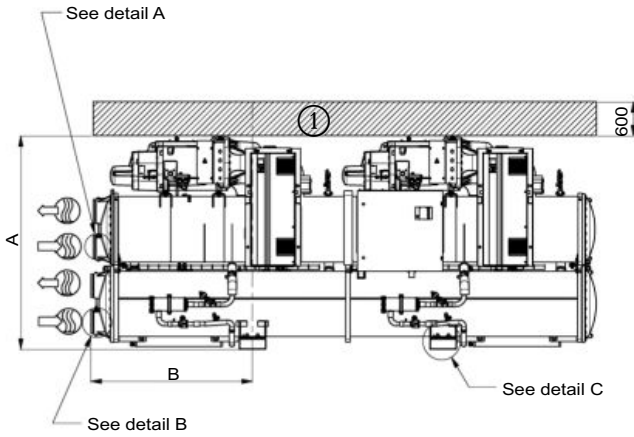

Dimensions in mm								
	A	B	C	D	E	F	G	H
<b>30XW-VZE/30XWHVZE</b>								
<b>851</b>	1998	1514	1164	4730	1162	219,1	219,1	4500
<b>1001</b>	1998	1514	1164	4730	1162	219,1	219,1	4500
<b>1101</b>	2051	1514	1164	4730	1264	219,1	219,1	4500
<b>1201</b>	2051	1514	1164	4730	1264	219,1	219,1	4500
<b>1301</b>	2051	1514	1164	4730	1264	219,1	219,1	4500

**Legend**

All dimensions are given in mm

- Services clearances required
- Space required to remove
- Inlet water
- Outlet water
- Electrical supply entry

**NOTES:**

Drawings are not contractually binding. Before designing an installation, consult the certified dimensional drawings supplied with the unit or available on request.

For the positioning of the fixing points, weight distribution and centre of gravity coordinates please refer to the dimensional drawings.

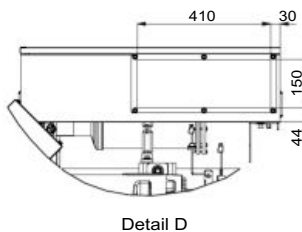
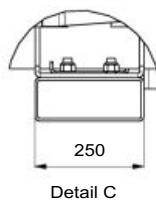
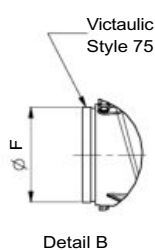
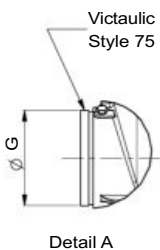

## WATER-SOURCED VARIABLE-SPEED SCREW HEAT PUMPS



- Low energy consumption
- High reliability
- Easy and fast installation
- Minimised operating sound levels
- Environmental care
- Designed to support green building design

## 30XWHV

Nominal heating capacity 648-1932 kW  
Nominal cooling capacity 587-1741 kW

The 30XW-V/30XWHV water-sourced units are the premium solution for commercial and industrial applications where installers, consultants and building owners require maximum quality and optimal performances, especially at part load.

The 30XW-V/30XWHV units are designed to meet current and future requirements in terms of energy efficiency, versatility and compactness. They feature exclusive inverter-driven screw compressors - an evolution of the proven traditional Carrier twin-rotor screw compressor design. Other features include:

- The new SmartVu™ control
- Mechanically cleanable flooded heat exchangers
- Refrigerant R-134a

The 30XW-V/30XWHV range is split into two versions:

- 30XW-V for air conditioning applications
- 30XWHV for heating applications

As standard, the unit can provide an evaporator leaving water temperature down to 3.3°C, and when operating as a heat pump, it can deliver up to 50°C on the condenser side.



CARRIER participates in the ECP programme for LCP-HP  
Check ongoing validity of certificate:  
[www.eurovent-certification.com](http://www.eurovent-certification.com)



## CUSTOMER BENEFITS

### Low energy consumption

- The 30XW-V/30XWHV was designed for high performance both at full load and at part load.
  - Eurovent certified values per EN14511-3:2022: SEPR up to 8.07 and SEER up to 8.43
- High energy efficiency
  - Inverter-driven twin-rotor screw compressors allow precise capacity matching of building load changes and significantly reduce unit power input, especially at part-load.
  - Flooded multi-pipe heat exchangers for increased heat exchange efficiency.
  - Electronic expansion device permits operation at a lower condensing pressure and improved utilisation of the evaporator heat exchange surface.
- Optimised electrical performance
  - All 30XW-V/30XWHV units comply with class 3 of standard EN61800-3. Category C3 refers to industrial environments. With option 282 category C2 compliance is possible.
  - Inverter-driven motors ensure negligible start-up current (value is lower than the maximum unit current draw)

### High reliability

- The 30XW-V and 30XWHV ranges offer increased global performance as well as Carrier's acclaimed product quality and reliability. Major components are selected and tested to minimize failures possibility, as well as many design choices have been taken in this perspective.
- Inverter-driven screw compressors
  - Industrial-type screw compressors with oversized bearings and motor cooled by suction gas.
  - The inverter is optimised for each compressor motor to ensure reliable operation and easy maintenance.
  - All compressor components are easily accessible on site minimising down-time.
- Refrigerant circuits
  - Two independent refrigerant circuits (from 1000 kW upwards); the second one automatically takes over, if the first one develops a fault, maintaining partial cooling under all circumstances.
- Evaporator
  - Electronic paddle-free flow switch. Auto-setting according to cooler size and fluid type.
- Auto-adaptive control
  - Control algorithm prevents excessive compressor cycling
  - Automatic compressor unloading in case of abnormally high condensing pressure or discharge temperature.
- Exceptional endurance tests
  - Partnerships with specialised laboratories and use of limit simulation tools (finite element calculation) for the design of critical components.
  - Transport simulation test in the laboratory on a vibrating table and then on an endurance circuit (based on a military standard).

### Easy and fast installation

- Compact design
  - The 30XW-V/30XWHV units are designed to offer compact dimensions for easy installation.
  - With a width of approximately 1.25 m up to 1000 kW the units can pass through standard door openings and only require minimum floor space in the plant room.
- Simplified electrical connections
  - Main disconnect switch with high trip capacity
  - Transformer supply to the integrated control circuit (400/24 V)
- Simplified water connections
  - Victaulic connections on the evaporator and condenser
  - Practical reference marks for entering and leaving water connections
  - Possibility to reverse the heat exchanger water inlet and outlet at the factory
  - Possibility to modify the number of heat exchanger passes
- Fast commissioning
  - Systematic factory operation test before shipment
  - Quick-test function for step-by-step verification of the instruments, expansion devices and compressors.

### Minimised operating sound levels

- The inverter technology used for the compressor motors minimises noise levels at part load operation. In two-compressor units at 25% of the maximum load the unit sound power level is reduced by 10 dB(A).
- Standard unit features include:
  - Silencers on the compressor discharge line.
  - Sound insulation on the components that are most subjected to radiated noise.
- Option 257 further reduces the global unit sound level.

### Environmental care

- R-134a refrigerant
  - HFC-refrigerant with zero ozone depletion potential
- Leak-tight refrigerant circuit
  - Reduction of leaks as no capillary tubes and flare connections are used
  - Verification of pressure transducers and temperature sensors without transferring refrigerant charge
  - Discharge line shut-off valve and liquid line service valve for simplified maintenance.

### Designed to support green building design

- A green building is a building that is environmentally sustainable and has been designed, constructed and is operated to minimise the total impact on the environment. The underlying principles of this approach: The resulting building will be economical to operate, offer increased comfort and create a healthier environment for the people who live and work there, increasing productivity.

## CUSTOMER BENEFITS

- The air conditioning system can use between 30 and 40% of the annual building energy consumption. Selection of the right air conditioning system is one of the main aspects to consider when designing a green building. For buildings with a variable load throughout the year, 30XW-V/30XWHV units offers a solution to this important challenge.
- A number of green building certification programs exist in the market and offer third-party assessment of green building measures for a wide variety of building types.
- The following example looks at how Carrier's new 30XW-V/30XWHV range helps customers involved in LEED® building certification.

### 30XW-V/30XWHV and LEED® certification

The LEED® (Leadership in Energy and Environmental Design) green building certification programme is a pre-eminent programme to rate the design, construction and operation of green buildings with points assigned in seven credit categories:

- Sustainable Sites (SS)
- Water Efficiency (WE)
- Energy & Atmosphere (EA)
- Materials & Resources (MR)
- Indoor Environmental Quality (IEQ)
- Innovation in Design (ID)
- Regional Priority (RP)

There are a number of different LEED® products.

While the strategies and categories assessed remain same, the point distribution varies to address different building types and application needs, for example according to New Construction, Schools, Core & Shell, Retail and Healthcare. All programmes now use the same point scale:

### 110 Possible LEED® points

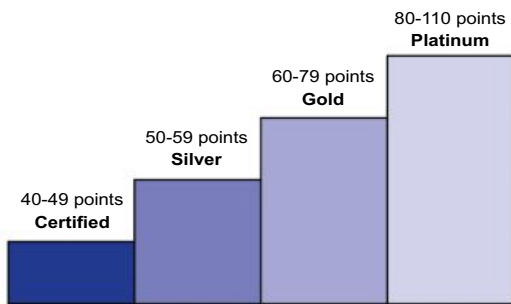

The majority of credits in LEED® rating systems are performance-based and achieving them is dependent on the impacts of each component or sub-system to the overall building.

While the LEED® green building certification programs do not certify products or services, the selection of the right products, systems or service programs is critical to obtain LEED® certification for a registered project, because the right products or service programmes can help meet the goals of green construction and ongoing operation and maintenance.

The choice of heating, ventilating and air conditioning (HVAC) products in particular can have a significant impact on LEED® certification, as the HVAC system directly impacts two categories that together influence 40% of the available points.

### Overview of LEED® for new construction and major renovations

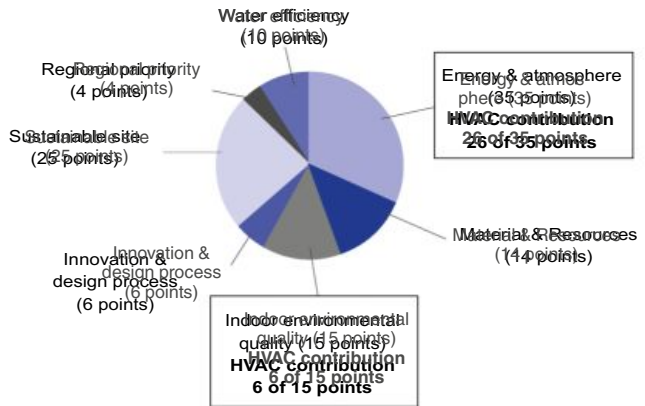

The new 30XW-V/30XWHV units from Carrier can assist building owners to earn LEED® points in particular in the Energy & Atmosphere (EA) credit category and help address the following prerequisites and credit requirements:

- **EA prerequisite 2: Minimum energy Performance**  
The 30XW-V/30XWHV exceeds the energy efficiency requirements of ASHRAE 90.1-2007; therefore it complies with the prerequisite standard.
- **EA prerequisite 3: Fundamental Refrigerant Management**  
The 30XW-V/30XWHV does not use chlorofluorocarbon (CFC) refrigerants thus satisfying the prerequisite statement.
- **EA credit 1: Optimise energy performance (1 to 19 points)**  
Points for this credit are assigned depending on the energy cost reduction virtually achievable by the new building, compared to ASHRAE 90.1-2007 reference. The 30XW-V/30XWHV, which is designed for high performance especially during part load operation, contributes reducing the energy consumption of the building and therefore helps gaining points within this credit. In addition, the Carrier HAP (Hourly Analyses Program) can be used as an energy analyses program complying with the modeling requirements for this credit and produce reports that are easily transferable to LEED® templates.
- **EA credit 4: Enhanced refrigerant management (2 points)**  
With this credit, LEED® awards systems that minimise the Ozone Depletion Potential (ODP) and Global Warming Potential (GWP) of the system. The 30XW-V/30XWHV uses a reduced R134a charge and therefore contributes toward satisfying this credit under LEED®.

**NOTE: This section describes the prerequisites and credit requirements in LEED® for New Construction and is directly related to the 30XW-V/30XWHV. Other prerequisites and credit requirements are not directly and purely related to the air-conditioning unit itself, but more to the control of the complete HVAC system.**

i-Vu®, Carrier's open control system, has features that can be valuable for:

- EA prerequisite 1: Fundamental commissioning of energy management system
- EA credit 3: Enhanced commissioning (2 points)
- EA credit 5: Measurements and verification (3 points).

**NOTE: Products are not reviewed or certified under LEED®. LEED® credit requirements cover the performance of materials in aggregate, not the performance of individual products or brands. For more information on LEED®, visit [www.usgbc.org](http://www.usgbc.org).**

## TECHNICAL INSIGHTS

### SmartVu™



- New innovative smart control features :
  - An intuitive and user-friendly, coloured, 7" interface
  - 10 languages available on choice: DE, EN, ES, FR, T, NL, PT, TR, TU + one additional customer choice
  - Screen-shots with concise and clear information in local languages
  - Complete menu, customised for different users (end user, service personnel and Carrier-factory technicians)
  - Setpoint offset based on the outside air temperature
  - Safe operation and unit setting: Password protection ensures that unauthorised people cannot modify any advanced parameters
  - Simple and "smart" intelligence uses data collection from the constant monitoring of all machine parameters to optimise unit operation
  - Night-mode: Cooling capacity management for reduced noise level.
  - With hydraulic module: Water pressure display and water flow rate calculation.
- Energy management :
  - Internal time schedule clock controls chiller on/off times and operation at a second set-point
  - The DCT (Data Collection Tool) records the alarms history to simplify and facilitate service operations.
- Maintenance functions :
  - F-Gas regulation leak check reminder alert
  - Maintenance alert can be configured to days, months or hours of operation
- Advanced communication features :
  - Easy and high-speed communication technology over Ethernet (IP) to a centralised building management system
  - Access to multiple unit parameters.

### Remote Management (Standard)

- Units with SmartVu™ control can be easily accessed from the internet, using a PC with an Ethernet connection. This makes remote control quick and easy and offers significant advantages for service operations.
- Aquaforce with Greenspeed® Intelligence is equipped with an RS485 serial port that offers multiple remote control, monitoring and diagnostic possibilities. When networked with other Carrier equipment through the CCN (Carrier Comfort Network - proprietary protocol), all components form a HVAC system fully-integrated and balanced through one of the Carrier's network system products, like the Chiller System analyzer or the Plant System analyzer (optional).
- The chiller also communicates with other building management systems via optional communication gateways (BACnet, LON or JBus).
- The following commands/visualisations are possible from remote connection:
  - Start/Stop of the machine
  - Dual set-point management: Through a dedicated contact is possible to activate a second set-point (example, unoccupied mode)
  - Demand limit setting: To limit the maximum chiller capacity to a predefined value
  - Water pump control: These outputs control the contactors of one/two evaporator water pumps.
  - Water pumps changeover (only with hydraulic module options): These contacts are used to detect a water pump operation fault and automatically change over to the other pump.
  - Operation visualisation: indication if the unit is operating or if it is in stand-by (no cooling load)
  - Alarm visualisation.

### Remote management (EMM option)

- The Energy Management Module offers extended remote control possibilities:
  - Room temperature: Permits set-point reset based on the building indoor air temperature (if Carrier thermostats are installed)
  - Set-point reset: Allows reset of the cooling set-point based on a 4-20 mA or 0-10 V signal
  - Demand limit: Permits limitation of the maximum chiller capacity based on 0-10 V signal
  - Demand limit 1 and 2: Closing of these contacts limits the maximum chiller capacity to two predefined values.
  - User safety: This contact can be used for any customer safety loop; opening the contact generates a specific alarm.
  - Ice storage end: When ice storage has finished, this input permits return to the second set-point (unoccupied mode).
  - Time schedule override: Closing of this contact cancels the programmed time schedule.
  - Out of service: This signal indicates that the chiller is completely out of service.
  - Chiller capacity: This analogue output (0-10 V) gives an immediate indication of the chiller capacity.
  - Alert indication: This volt-free contact indicates the necessity to carry out a maintenance operation or the presence of a minor fault.
  - Compressors running status: Set of outputs (as many as the compressors number) indicating which compressors are running.

## TECHNICAL INSIGHTS

### Remote management (EMM option)

The Energy Management Module offers extended remote control possibilities:

- Room temperature: permits set-point reset based on the building indoor air temperature (with Carrier thermostat)
- Set point reset: ensures reset of the cooling set-point based on a 4-20 mA or 0-10 V signal
- Demand limit: permits limitation of the maximum chiller power or current based on a 0-10 V signal
- Demand limit 1 and 2: closing of these contacts limits the maximum chiller power or current to two predefined values
- User safety: this contact can be used for any customer safety loop; opening the contact generates a specific alarm
- Ice storage end: when ice storage has finished, this input permits return to the second set-point (unoccupied mode)
- Time schedule override: closing of this contact cancels the time schedule effects
- Out of service: this signal indicates that the chiller is completely out of service
- Chiller capacity: this analogue output (0-10 V) gives an immediate indication of the chiller capacity
- Alert indication: this volt-free contact indicates the necessity to carry out a maintenance operation or the presence of a minor fault.
- Compressors running status : set of outputs (as many as the compressors number) indicating which compressors are running.

### New inverter-driven Thunderbolt screw compressor

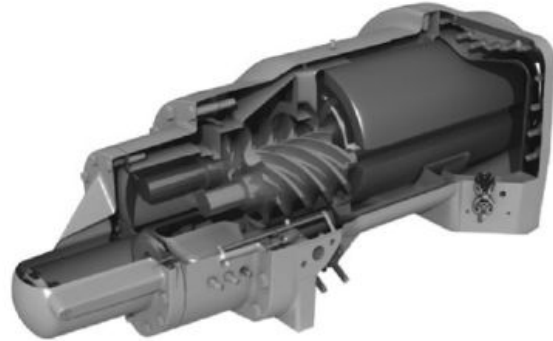

- The new generation of Carrier inverter-driven screw compressors benefits from Carrier's long experience in the development of twin-rotor screw compressors. The design of the Thunderbolt compressors is based on the successful 06T screw compressor, core of the well-known Aquaforce series.
- Advanced control algorithms combine inverter frequency output with motor input logic to minimise mechanical part stress, resulting in best compression performance and high chiller reliability. The compressor is equipped with bearings with oversized rollers, oil pressure lubricated for reliable and durable operation, even at maximum load.
- Screw compressors use positive displacement principle to compress gases at higher pressure. As a result, in case of exceptional high temperature condenser side (due for example to water-pipes fouling or operation in harsh climate with an external dry cooler) the compressor does not switch off, but continues operation at reduced capacity (unloaded mode).
- The silencer in the discharge line considerably reduces discharge gas pulsations for much quieter operation.
- The condenser includes an oil separator that minimises the amount of oil in circulation in the refrigerant circuit and re-directs it to the compressor function.

### Digit number

1	2	3	4	5	6	7	8	9	10	11	12	13	14	15	16	17	18
3	0	X	W	-	V	0	2	5	4	B	0	0	0	1	-		

**Legend :**

- Digit 1 to 4: Water-cooled chiller with screw compressor
- Digit 5: Application type, - = Cooling, H = Heating
- Digit 6: Efficiency, V = Variable
- Digit 7 to 10: Model number based on cooling capacity in kW
- Digit 11: Index for major product modification (visible impact for customer)
- Digit 12 to 15: Counter used to generate a one time product code
- Digit 16: Not used



## OPTIONS

Options	No.	Description	Advantages	Use
Light-brine solution, down to -3°C	8	Implementation of new algorithms of control to allow chilled brine solution production down to -3°C when ethylene glycol is used (0°C with propylene glycol)	Matches with most application requirements for ground-sourced heat pumps and fits with many industrial processes requirements	580-1710 (see dedicated paragraph)
Master/slave operation	58	Unit equipped with supplementary water outlet temperature sensor kit to be field-installed allowing master/slave operation of two units connected in parallel	Optimised operation of two chillers connected in parallel with operating time equalisation	580-1710
Single power connection point	81	Unit power connection via one main supply connection	Quick and easy installation	1150-1710
Evap. pump power/control circuit	84	Unit equipped with an electrical power and control circuit for one pump evaporator side	Quick and easy installation: the control of fixed speed pumps is embedded in the unit control	580-1710
Evaporator dual pumps electrical power / control circuit	84D	Unit equipped with an electrical power and control circuit for two pumps evaporator side	Quick and easy installation: the control of fixed speed pumps is embedded in the unit control	580-1710
Cond. pump power/control circuit	84R	Unit equipped with an electrical power and control circuit for one pump condenser side	Quick and easy installation: the control of fixed speed pumps is embedded in the unit control	580-1710
Cond. dual pumps power/control circuit	84T	Unit equipped with an electrical power and control circuit for two pumps condenser side	Quick and easy installation: the control of fixed speed pumps is embedded in the unit control	580-1710
Condenser insulation	86	Thermal condenser insulation	Minimizes thermal dispersions condenser side (key option for heat pump or heat recovery applications) and allows compliancy with special installation criteria (hot parts insulated)	580-1710
Service valve set	92	Liquid line valve (evaporator inlet) and compressor suction line valve	Allow isolation of various refrigerant circuit components for simplified service and maintenance	580-1710
Evaporator with one pass less	100C	Evaporator with one pass on the water side. Evaporator inlet and outlet on opposite sides.	Easy to install, depending on site. Reduced pressure drops	580-1710
Condenser with one pass less	102C	Condenser with one pass on the water side. Condenser inlet and outlet on opposite sides.	Easy to install, depending on site. Reduced pressure drops	580-1710
21 bar evaporator	104	Reinforced evaporator for extension of the maximum water-side service pressure to 21 bar (standard 10 bar)	Covers applications with a high water column evaporator side (typically high buildings)	580-1710
21 bar condenser	104A	Reinforced condenser for extension of the maximum water-side service pressure to 21 bar (standard 10 bar)	Covers applications with a high water column condenser side (typically high buildings)	580-1710
Reversed evaporator water connections	107	Evaporator with reversed water inlet/outlet	Easy installation on sites with specific requirements	580-1710
Reversed condenser water connections	107A	Condenser with reversed water inlet/outlet	Easy installation on sites with specific requirements	580-1710
LON gateway	148D	Two-directional communication board complying with LON protocol	Connects the unit by communication bus to a building management system	580-1710
Bacnet over IP gateway	149	Two-directional high-speed communication using BACnet protocol over Ethernet network (IP)	Easy and high-speed connection by ethernet line to a building management system. Allows access to multiple unit parameters	580-1710
Modbus over IP and RS485	149B	Bi-directional high-speed communication using Modbus protocol over Ethernet network (IP)	Easy and high-speed connection by ethernet line to a building management system. Allows access to multiple unit parameters	580-1710
Condensing temperature limitation	150B	Limitation of the maximum condenser leaving water temperature to 45°C	Reduced maximum power input and current absorption: power cables and protection elements can therefore be downsized	580-1710
Control for low condensing temperature systems	152	Output signal (0-10 V) to control the condenser water inlet valve	Simple installation: for applications with cold water at condenser inlet (ex. ground-source, groundwater-source, superficial water-source applications) the signal permits to control a 2 or 3-way valve to maintain condenser water temperature (and so condensing pressure) at acceptable values	580-1710
Energy Management Module EMM	156	Control board with additional inputs/outputs. See Energy Management Module option chapter	Extended remote control capabilities (Set-point reset, ice storage end, demand limits, boiler on/off command...)	580-1710
Leak detection	159	0-10 V signal to report any refrigerant leakage in the unit directly on the controller (the leak detector itself must be supplied by the customer)	Immediate customer notification of refrigerant losses to the atmosphere, allowing timely corrective actions	580-1710



## OPTIONS

Options	No.	Description	Advantages	Use
Dual relief valves on 3-way valve	194	Three-way valve upstream of dual relief valves on the evaporator and the oil separator	Valve replacement and inspection facilitated without refrigerant loss. Comforms to European standard EN378/BGVD4	580-1710
Compliance with Swiss regulations	197	Additional tests on the water heat exchangers: supply (additional of PED documents) supplementary certificates and test certifications	Conformance with Swiss regulations	580-1710
Compliance with Russian regulations	199	EAC certification	Conformance with Russian regulations	580-1710
Compliance with Australian regulations	200	Unit approved to Australian code	Conformance with Australian regulations	580-1710
Low noise level	257	Evaporator sound insulation	3 dB(A) quieter than standard unit	580-1710
Welded evaporator water connection kit	266	Victaulic piping connections with welded joints	Easy installation	580-1710
Welded condenser water connection kit	267	Victaulic piping connections with welded joints	Easy installation	580-1710
Flanged evaporator water connection kit	268	Victaulic piping connections with flanged joints	Easy installation	580-1710
Flanged condenser water connection kit	269	Victaulic piping connections with flanged joints	Easy installation	580-1710
Thermal compressor insulation	271	The compressor is covered with a thermal insulation layer	Prevents air humidity to condensate on the compressor surface	580-1710
EMC classification C2, as per EN 61800-3	282	Additional RFI filters on the unit power line	Reduces electromagnetic interferences. Increase the variable frequency drive (VFD) immunity level according to first environment (so called, residential environment) requirements and allow its compliancy with emissions level required in category C2	580-1710
Fast Capacity Recovery	295	New software algorithms to allow quick restart and fast loading while preserving unit-reliability	Full capacity recovery in approximately 6 minutes after power failure. Matches requirements of typical critical missions applications	580-1710
Compliance with UAE regulation	318	Additional label on the unit with rated power input, rated current and EER following AHRI 550/590	Compliance with ESMA standard UAE.S 5010-5:2019.	580-1710
Compliance with Morocco regulation	327	Specifics documents according Morrocco regulation	Conformance with Morocco regulations	580-1710

PHYSICAL DATA, 30XW-V UNITS

30XW-V / 30XWHV			580	630	810	880	1150	1280	1470	1570	1710	
<b>Heating</b>												
<b>Standard unit</b> Full load performances *	HW1	Nominal capacity	kW	649	719	890	974	1261	1428	1594	1761	1932
		COP	kW/kW	4,64	4,53	4,56	4,43	4,62	4,61	4,55	4,33	4,16
	HW2	Nominal capacity	kW	687	767	956	1021	1335	1524	1712	1898	2067
		COP	kW/kW	6,15	5,98	5,96	5,81	6,05	6,00	5,82	5,49	5,34
<b>Standard unit</b> Seasonal energy efficiency **	HW2	SCOP <sub>30/35°C</sub>	kWh/kWh	7,32	7,05	7,21	6,96	6,95	6,66	6,37	6,13	5,87
		η <sub>s heat</sub> <sub>30/35°C</sub>	%	285	274	280	270	270	259	247	237	227
		P <sub>rated</sub>	kW	818	913	1134	1216	1589	1815	2041	2263	2463
<b>Cooling</b>												
<b>Standard unit</b> Full load performances *	CW1	Nominal capacity	kW	587	652	812	858	1140	1305	1461	1604	1741
		EER	kW/kW	5,44	5,31	5,25	5,07	5,45	5,50	5,38	5,05	4,94
	CW2	Nominal capacity	kW	704	754	910	863	1364	1508	1581	1876	2040
		EER	kW/kW	6,46	6,08	5,80	5,22	6,38	6,19	5,55	5,60	5,63
<b>Standard unit</b> Seasonal energy efficiency **		<b>SEER<sub>12/7°C</sub> Comfort low temp.</b>	<b>kWh/kWh</b>	<b>7,94</b>	<b>7,62</b>	<b>8,43</b>	<b>7,93</b>	<b>8,31</b>	<b>8,19</b>	<b>7,74</b>	<b>7,70</b>	<b>7,34</b>
		η <sub>s cool</sub> <sub>12/7°C</sub>	%	315	302	334	314	329	325	307	305	290
		SEPR <sub>12/7°C</sub> Process high temp.	kWh/kWh	8,07	8,02	7,73	6,76	8,04	8,07	7,96	7,89	7,49
Integrated Part Load Value IPLV.SI			kW/kW	9,060	9,120	9,450	8,950	9,240	9,300	9,170	9,300	8,980
<b>Sound levels - standard unit</b>												
Sound power level <sup>(1)</sup>			dB(A)	105	105	105	105	106	106	106	106	106
Sound pressure level at 1 m <sup>(2)</sup>			dB(A)	87	87	87	87	87	87	87	87	87
<b>Sound levels - standard unit + option 257 <sup>(3)</sup></b>												
Sound power level <sup>(1)</sup>			dB(A)	102	102	102	102	103	103	103	103	103
Sound pressure level at 1 m <sup>(2)</sup>			dB(A)	84	84	84	84	84	84	84	84	84
<b>Dimensions - standard unit</b>												
Length			mm	3059	3059	3290	3290	4730	4730	4730	4730	4730
Width			mm	1087	1087	1237	1237	1164	1164	1255	1255	1255
Height			mm	1743	1743	1950	1950	1997	1997	2051	2051	2051
Operating weight <sup>(4)</sup>			kg	3152	3190	4157	4161	7322	7398	7574	7770	7808
<b>Compressors</b>												
Semi-hermetic 06T screw compressors, 60 r/s												
Circuit A			-	1	1	1	1	1	1	1	1	1
Circuit B			-	-	-	-	1	1	1	1	1	

\* In accordance with standard EN14511-3:2022.  
 \*\* In accordance with standard EN14825:2022, average climate  
 HW1 Heating mode conditions: Evaporator entering/leaving water temperature 10°C/7°C, condenser entering/leaving water temperature 40°C/45°C, evaporator and condenser fouling factor 0 m<sup>2</sup>. k/W  
 HW2 Heating mode conditions: Evaporator entering/leaving water temperature 10°C/7°C, condenser entering/leaving water temperature 30°C/35°C, evaporator and condenser fouling factor 0 m<sup>2</sup>. k/W  
 CW1 Cooling mode conditions: Evaporator water entering/leaving temperature 12°C/7°C, condenser entering/leaving water temperature 30°C/35°C, evaporator and condenser fouling factor 0 m<sup>2</sup>.K/W  
 CW2 Cooling mode conditions: Evaporator water entering/leaving temperature 23°C/18°C, condenser entering/leaving water temperature 30°C/35°C, evaporator and condenser fouling factor 0 m<sup>2</sup>.K/W  
 (1) In dB ref=10<sup>-12</sup> W, (A) weighting. Declared dualnumber noise emission values in accordance with ISO 4871 (with an associated uncertainty of +/-3dB(A)). Measured in accordance with ISO 9614-1 and certified by Eurovent.3dB(A)). Measured in accordance with ISO 9614-1 and certified by Eurovent.  
 (2) in dB ref 20μPa, (A) weighting. Declared dualnumber noise emission values in accordance with ISO 4871 (with an associated uncertainty of +/-3dB(A)). For information, calculated from the sound power level Lw(A).  
 (3) Option 257 = Low noise level  
 (4) Weight shown is guideline only. To find out the unit refrigerant charge, please refer to the unit nameplate  
 η<sub>s heat</sub><sub>30/35°C</sub> & SCOP<sub>30/35°C</sub> Values calculated in accordance with EN14825:2022  
 η<sub>s cool</sub><sub>12/7°C</sub> & SEER<sub>12/7°C</sub> **Bold values compliant to Ecodesign regulation: (EU) No 2016/2281 for Comfort application**  
 SEPR<sub>12/7°C</sub> Values calculated in accordance with EN14825:2022  
 NA Non Authorized for the specific application for CEE market  
 IPLV.SI Calculations according to standard performances AHRI 551-591 (SI).



Eurovent certified values



AHRI certified values  
30XW-V only

## PHYSICAL DATA, 30XW-V UNITS

30XW-V / 30XWHV		580	630	810	880	1150	1280	1470	1570	1710	
<b>Oil - standard unit</b>											
Circuit A	l	32	32	36	36	32	32	36	36	36	
Circuit B	l	-	-	-	-	32	32	32	36	36	
<b>Refrigerant - standard unit</b>		R-134a, GWP=1430 following ARI4									
Circuit A	kg	130	130	180	175	120	120	115	115	110	
	teqCO <sub>2</sub>	186	186	257	250	172	172	164	164	157	
Circuit B	kg	-	-	-	-	120	120	120	115	110	
	teqCO <sub>2</sub>	-	-	-	-	172	172	172	164	157	
<b>Capacity control</b>		SmartVu™, inverter-driven compressor, electronic expansion valve (EXV)									
Minimum capacity	%	30	30	15	15	30	30	15	15	15	
<b>Evaporator</b>		Multi-pipe flooded type									
Water volume	l	106	106	154	154	297	297	297	297	297	
Water connections (Victaulic)	in	6	6	8	8	8	8	8	8	8	
Drain and vent connections (NPT)	in	3/8	3/8	3/8	3/8	3/8	3/8	3/8	3/8	3/8	
Max. water-side operating pressure	kPa	1000	1000	1000	1000	1000	1000	1000	1000	1000	
<b>Condenser</b>		Multi-pipe flooded type									
Water volume	l	112	112	165	165	340	340	340	340	340	
Water connections (Victaulic)	in	6	6	8	8	8	8	8	8	8	
Drain and vent connections (NPT)	in	3/8	3/8	3/8	3/8	3/8	3/8	3/8	3/8	3/8	
Max. water-side operating pressure	kPa	1000	1000	1000	1000	1000	1000	1000	1000	1000	

## ELECTRICAL DATA

30XW-V/30XWHV		580	630	810	880	1150	1280	1470	1570	1710
<b>Power circuit</b>										
Nominal power supply	V-ph-Hz	400-3-50								
Voltage range	V	360-440								
<b>Control circuit</b>										
24 V via the built-in transformer										
<b>Start-up current*</b>										
A Lower than the operating current										
<b>Maximum power factor**</b>										
		0,91-0,93	0,91-0,93	0,91-0,93	0,91-0,93	0,91-0,93	0,91-0,93	0,91-0,93	0,91-0,93	0,91-0,93
<b>Cosine phi</b>										
		>0,98	>0,98	>0,98	>0,98	>0,98	>0,98	>0,98	>0,98	>0,98
<b>Total harmonic distortion†</b>										
	%	35-45	35-45	35-45	35-45	35-45	35-45	35-45	35-45	35-45
<b>Maximum power input***</b>										
Circuit A	kW	155	193	222	246	155	193	222	222	246
Circuit B	kW	-	-	-	-	155	193	193	222	246
With option 81	kW	-	-	-	-	310	386	415	444	492
<b>Eurovent current draw****</b>										
Circuit A	A	175	200	240	265	175	200	240	240	265
Circuit B	A	-	-	-	-	175	200	200	240	265
With option 81	A	-	-	-	-	350	400	440	480	530
<b>Maximum current draw (Un)***</b>										
Circuit A	A	245	300	346	383	245	300	346	346	383
Circuit B	A	-	-	-	-	245	300	300	346	383
With option 81	A	-	-	-	-	490	600	646	692	766
<b>Maximum current draw (Un -10%)***</b>										
Circuit A	A	270	330	380	421	270	330	380	380	421
Circuit B	A	-	-	-	-	270	330	330	380	421
With option 81	A	-	-	-	-	540	660	710	760	842
<b>Maximum power input with option 150B***</b>										
Circuit A	kW	141	173	199	221	141	173	199	199	221
Circuit B	kW	-	-	-	-	141	173	173	199	221
With option 81	kW	-	-	-	-	282	346	372	398	442
<b>Maximum current draw (Un) with option 150B***</b>										
Circuit A	A	222	272	314	348	222	272	314	314	348
Circuit B	A	-	-	-	-	222	272	272	314	348
With option 81	A	-	-	-	-	444	544	586	628	696
<b>Dissipated power†</b>										
	W	3000	4200	4700	5300	6000	8400	8900	9400	10600

\* Instantaneous start-up current

\*\* This can vary as a function of the short-circuit current/maximum current ratio of the system transformer. Values obtained at operation with maximum unit power input.

\*\*\* Values obtained at operation with maximum unit power input. Values given on the unit name plate.

\*\*\*\* Eurovent unit operating conditions: evaporator entering/leaving water temperature = 12°C/7°C, condenser entering/leaving water temperature = 30°C/35°C. Gross performances, not in accordance with EN14511-3:2022. These performances do not take into account the correction for the proportional heating capacity and power input generated by the water pump to overcome the internal pressure drop in the heat exchanger.

† Values obtained at operation with maximum unit power input.

## DIMENSIONS/CLEARANCES

### 30XW-V/30XWHV 580-880

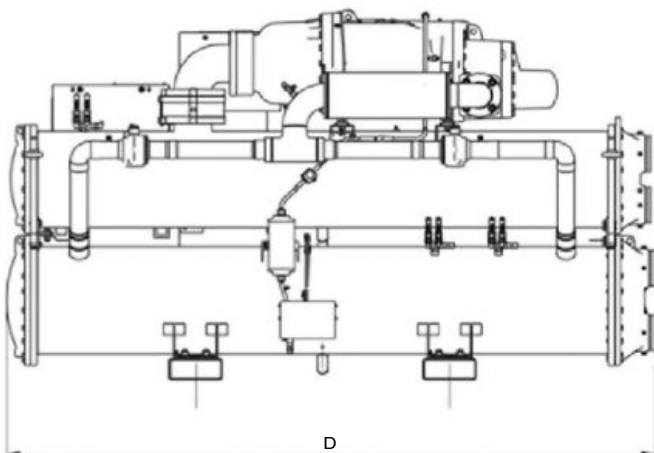
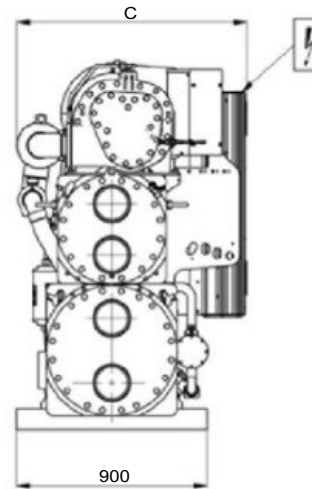
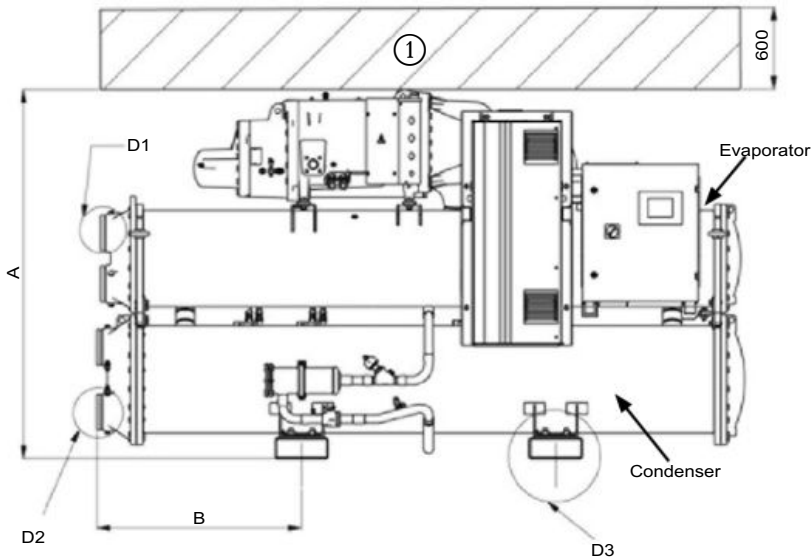

Dimensions in mm							
	A	B	C	D	E	F	G
30XW-V/30XWHV							
580	1743	968	1087	3059	168,3	168,3	2900
630	1743	968	1087	3059	168,3	168,3	2900
810	1950	1083	1237	3290	219,1	219,1	3100
880	1950	1083	1237	3290	219,1	219,1	3100

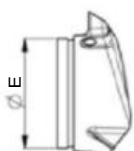
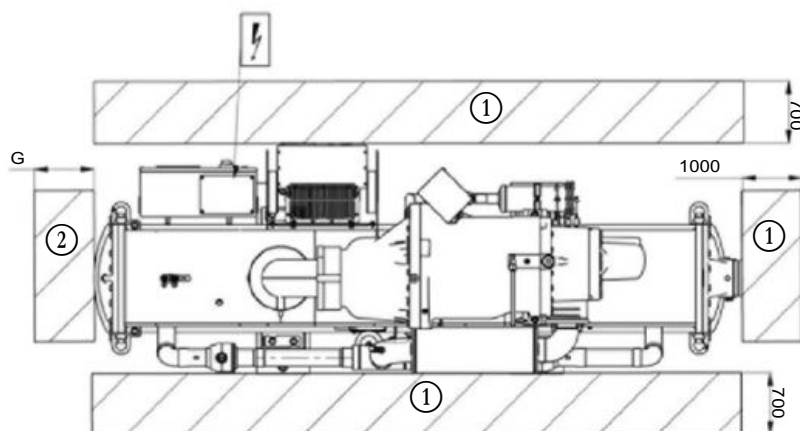

D1

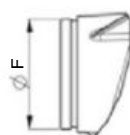

D2

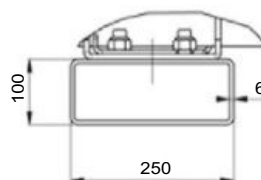

D3

#### Legend:

All dimensions are in mm.

- ① Required clearance for maintenance
- ② Recommended clearance for tube removal
- Water inlet
- Water outlet
- Power supply connection

**NOTE:** Drawings are not contractually binding. Before designing an installation, consult the certified dimensional drawings, available on request.



**DIMENSIONS/CLEARANCES**

**30XW-V/30XWHV 1150-1710**

PRESENTATION

COOLING

HEATING

AIR TREATMENT

CONTROLS

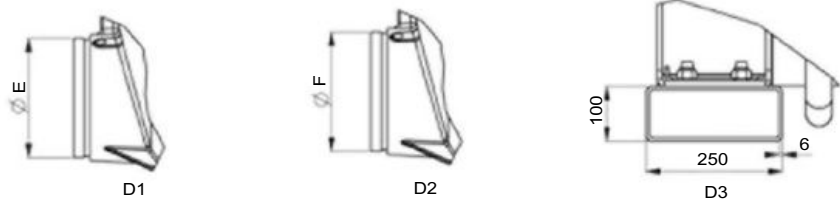
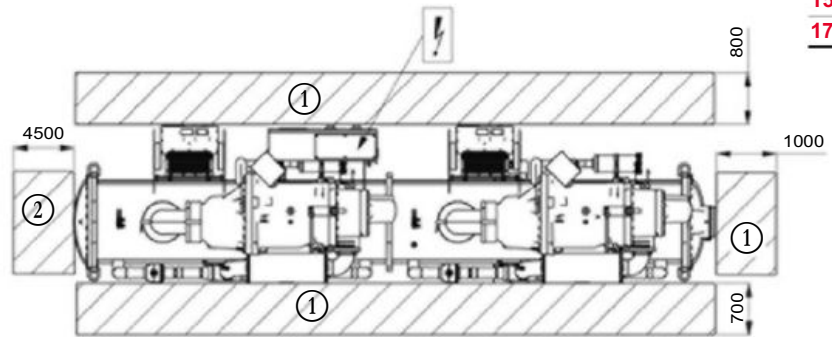
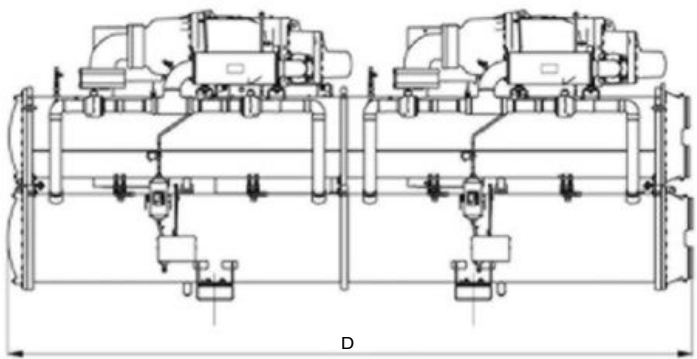
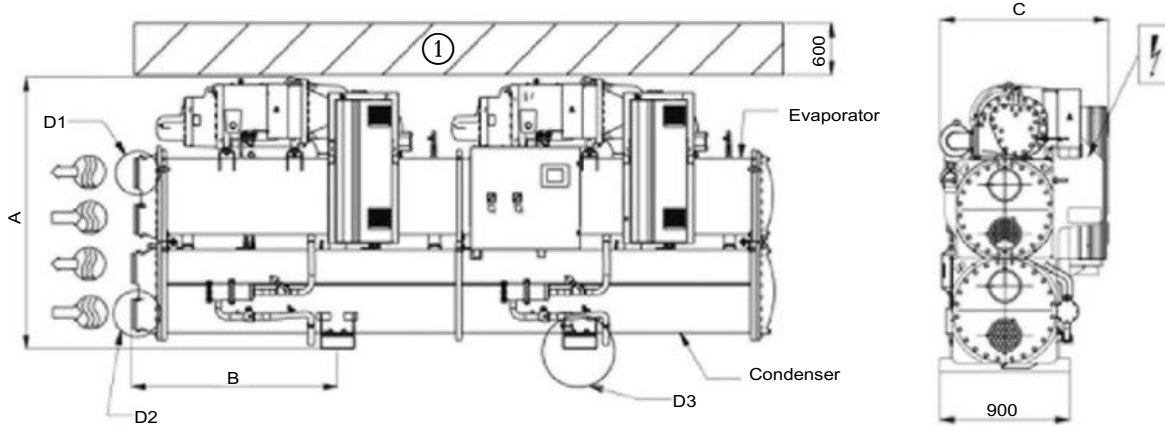

Dimensions in mm						
	A	B	C	D	E	F
<b>30XW-V/30XWHV</b>						
1150	1997	1514	1164	4730	219,1	219,1
1280	1997	1514	1164	4730	219,1	219,1
1470	2051	1514	1255	4730	219,1	219,1
1570	2051	1514	1255	4730	219,1	219,1
1710	2051	1514	1255	4730	219,1	219,1

- Legend:**  
 All dimensions are in mm.
- ① Required clearance for maintenance
  - ② Recommended clearance for tube removal
  - Water inlet
  - Water outlet
  - Power supply connection

**NOTE:** Drawings are not contractually binding. Before designing an installation, consult the certified dimensional drawings, available on request.

## WATER-SOURCED SCREW HEAT PUMPS



- Low energy consumption
- High reliability
- Easy and fast installation
- Low operating sound levels
- Environmental care

## 30XWH/30XWHP



Nominal heating capacity 317-2019 kW  
Nominal cooling capacity 269-1736 kW

The 30XW liquid chillers are the premium solution for industrial and commercial applications where installers, consultants and building owners require optimal performances and maximum quality.

The 30XW liquid chillers are designed to meet current and future requirements in terms of energy efficiency, flexibility of use and compactness. They use the most reliable technologies available today:

- Twin-rotor screw compressors with a variable capacity valve
- Refrigerant R134a
- Flooded heat exchangers that are mechanically cleanable
- Carrier SmartVu™ control with color touch screen user interface that includes 10 languages

To meet to all environmental and economic requirements, the 30XW is available in two efficiency classes:

- Entry-level efficiency 30XW units that offer an optimised balance of technical and economical aspects,
- Premium-efficiency 30XW-P units that offer unequalled energy efficiency to satisfy the most stringent demands of building owners wanting to reduce operating costs to the minimum.

The 30XW Aquaforce range is also split into two versions:

- 30XW for air conditioning and refrigeration applications
- 30XWH for heating applications

As standard, the unit can provide an evaporator leaving temperature down to 3,3°C (-12°C optional), and when operating as a heat pump, it can deliver up to 50°C (63°C optional) on the condenser side.



CARRIER participates in the ECP programme for LCP-HP  
Check ongoing validity of certificate:  
[www.eurovent-certification.com](http://www.eurovent-certification.com)

## CUSTOMER BENEFITS

### Low energy consumption

- SEPR up to 9,1 and SEER up to 7,7
- The high energy efficiency is reached through:
  - Twin-rotor screw compressor equipped with a high-efficiency motor and a variable capacity valve that permits exact matching of the cooling capacity to the load.
  - Flooded multi-pipe heat exchangers for increased heat exchange efficiency.
  - Electronic expansion device permitting operation at a lower condensing pressure and improved utilisation of the evaporator heat exchange surface.
  - Economizer system with electronic expansion device for increased cooling capacity (30XW-P).

### Low operating sound levels

- Standard unit features include:
  - Silencers on the compressors discharge line.
  - Silencers on the economiser return line.
  - Acoustic insulation on the components that are most subjected to radiated noise.
  - Option 257 further reduces the global unit sound level.

### Easy and fast installation

- Compact design
  - The 30XW units are designed to offer the most compact dimensions on the market.
  - With a width of approximately 1 m up to 1600 kW the units can pass through standard door openings and only require minimum floor space in the plant room.

**Compact, accessible unit - side view - sizes up to 1600 KW**

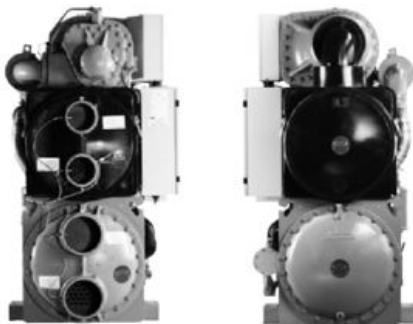

- Simplified electrical connections
  - Main disconnect switch with high trip capacity
  - Transformer to supply the integrated control circuit (400/24 V)
- Simplified hydraulic connections
  - Victaulic connections on the evaporator and condenser
  - Practical reference marks for entering and leaving water connections
  - Possibility to reverse the heat exchanger water inlet and outlet at the factory
  - Possibility to modify the number of heat exchanger passes
- Fast commissioning
  - Systematic factory operation test before shipment
  - Quick-test function for step-by-step verification of the instruments, expansion devices and compressors.

### Environmental care

- R-134a refrigerant
  - HFC refrigerant with zero ozone depletion potential
- Leak-tight refrigerant circuit
  - Reduction of leaks as no capillary tubes and flare connections are used
  - Verification of pressure transducers and temperature sensors without transferring refrigerant charge
  - Discharge line shut-off valve and liquid line service valve for simplified maintenance.

### High reliability and easy servicing

- The 30XW units offer increased global performance as well as Carrier's acclaimed product quality and reliability.
- Major components are selected and tested to minimize failures possibility, as well as many design choices have been taken in this perspective.
- Screw compressors
  - Industrial-type screw compressors with oversized bearings and motor cooled by suction gas.
  - All compressor components are easily accessible on site minimising down-time.
- Refrigerant circuit
  - Two independent refrigerant circuits (from 1000 kW upwards); the second one automatically takes over, if the first one develops a fault, maintaining partial cooling under all circumstances.
- Evaporator
  - Electronic paddle-free flow switch. Auto-setting according to cooler size and fluid type.
- Auto-adaptive control
  - Control algorithm prevents excessive compressor cycling (Carrier patent)
  - Automatic compressor unloading in case of abnormally high condensing pressure.
- Exceptional endurance tests
  - Partnerships with specialised laboratories and use of limit simulation tools (finite element calculation) for the design of critical components.
  - Transport simulation test in the laboratory on a vibrating table and then on an endurance circuit (based on a military standard).

## TECHNICAL INSIGHTS

### SmartVu™



- New innovative smart control features :
  - An intuitive and user-friendly, coloured, 4.3" interface
  - 1 languages available on choice: DE, EN, ES, FR, T, NL, PT, TR, TU + one additional customer choice
  - Screen-shots with concise and clear information in local languages
  - Complete menu, customised for different users (end user, service personnel and Carrier-factory technicians)
  - Setpoint offset based on the outside air temperature
  - Safe operation and unit setting: Password protection ensures that unauthorised people cannot modify any advanced parameters
  - Simple and "smart" intelligence uses data collection from the constant monitoring of all machine parameters to optimise unit operation
  - Night-mode: Cooling capacity management for reduced noise level.
  - With hydraulic module: Water pressure display and water flow rate calculation.
- Energy management :
  - Internal time schedule clock controls chiller on/off times and operation at a second set-point
  - The DCT (Data Collection Tool) records the alarms history to simplify and facilitate service operations.
- Maintenance functions :
  - F-Gas regulation leak check reminder alert
  - Maintenance alert can be configured to days, months or hours of operation
- Advanced communication features :
  - Easy and high-speed communication technology over Ethernet (IP) to a centralised building management system
  - Access to multiple unit parameters.

### Remote Management (Standard)

- Units with SmartVu™ control can be easily accessed from the internet, using a PC with an Ethernet connection. This makes remote control quick and easy and offers significant advantages for service operations.
- Aquaforce with Greenspeed® Intelligence is equipped with an RS485 serial port that offers multiple remote control, monitoring and diagnostic possibilities. When networked with other Carrier equipment through the CCN (Carrier Comfort Network - proprietary protocol), all components form a HVAC system fully-integrated and balanced through one of the Carrier's network system products, like the Chiller System anager or the Plant System anager (optional).
- The 30XW/P™ also communicates with other building management systems via optional communication gateways (BACnet, LON or JBus).
- The following commands/visualisations are possible from remote connection:
  - Start/Stop of the machine
  - Dual set-point management: Through a dedicated contact is possible to activate a second set-point (example, unoccupied mode)
  - Demand limit setting: To limit the maximum chiller capacity to a predefined value
  - Water pump control: These outputs control the contactors of one/two evaporator water pumps.
  - Water pumps changeover (only with hydraulic module options): These contacts are used to detect a water pump operation fault and automatically change over to the other pump.
  - Operation visualisation: indication if the unit is operating or if it is in stand-by (no cooling load)
  - Alarm visualisation.

### Remote management (EMM option)

- The Energy Management Module offers extended remote control possibilities:
  - Room temperature: Permits set-point reset based on the building indoor air temperature (if Carrier thermostats are installed)
  - Set-point reset: Allows reset of the cooling set-point based on a 4-20 mA or 0-10 V signal
  - Demand limit: Permits limitation of the maximum chiller capacity based on 0-10 V signal
  - Demand limit 1 and 2: Closing of these contacts limits the maximum chiller capacity to two predefined values.
  - User safety: This contact can be used for any customer safety loop; opening the contact generates a specific alarm.
  - Ice storage end: When ice storage has finished, this input permits return to the second set-point (unoccupied mode).
  - Time schedule override: Closing of this contact cancels the programmed time schedule.
  - Out of service: This signal indicates that the chiller is completely out of service.
  - Chiller capacity: This analogue output ( -1 gives an immediate indication of the chiller capacity.
  - Alert indication: This volt-free contact indicates the necessity to carry out a maintenance operation or the presence of a minor fault.
  - Compressors running status: Set of outputs (as many as the compressors number) indicating which compressors are running.

## TECHNICAL INSIGHTS

### 06T screw compressor

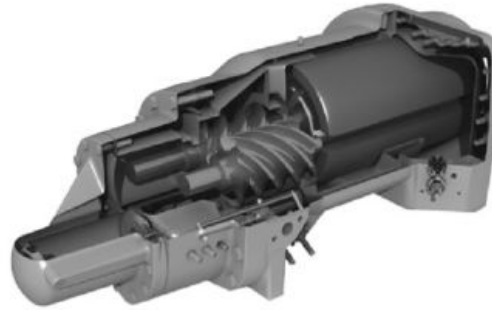

The new generation of the Carrier 06T screw compressors benefits from Carrier's long experience in the development of twin-rotor screw compressors. The compressor is equipped with bearings with oversized rollers, oil pressure lubricated for reliable and durable operation, even at maximum load.

A variable control valve controlled by the oil pressure permits infinitely variable cooling capacity. This system allows optimal adjustment of the compressor cooling capacity and ensures exceptionally high stability of the chilled water leaving temperature. Among the other advantages: if a fault occurs e.g. if the condenser is fouled or at very high water temperature, the compressor does not switch off, but continues operation with a reduced capacity (unloaded mode).

The silencer in the discharge line considerably reduces discharge gas pulsations for much quieter operation.

The condenser includes an oil separator that minimises the amount of oil in circulation in the refrigerant circuit and re-directs it to the compressor function.

### Digit number

1	2	3	4	5	6	7	8	9	1	1	1	1	1	1	1	1	1
3	0	X	W	-	-	0	2	5	4	B	0	0	0	0	1	-	

**Legend:**

- Digit 1 to 4 : Water-cooled chiller with screw compressor
- Digit 5 : Application type, - = Cooling, H = Heating
- Digit 6 : Efficiency, - = standard, P = premium
- Digit 7 to 10 : Model number based on cooling capacity in kW
- Digit 11 : Index for major product modification (visible impact for customer)
- Digit 12 to 15 : Counter used to generate a one time product code
- Digit 16 : Not used



## OPTIONS

Options	No.	Description	Advantages	Use
Low Brine with turbulators down to -15°C	6	Redesigned evaporator including turbulators to allow chilled brine solution production with low pressure drops on the entire negative application range, down to -15°C (including turbulators, extra insulation and algorithms).	Covers specific applications such as ice storage and industrial processes	-0254-P1762
Light-brine solution, down to -3°C	8	Implementation of new control algorithms and redesigned evaporator to allow chilled brine solution production down to -3°C when ethylene glycol is used (0°C with propylene glycol)	Matches with most application requirements for ground-sourced heat pumps and fits with many industrial processes requirements	-0254-P1762
IP44 electrical protection level	20	Control box tightness reinforced Electrical box enclosure and outside electrical component following IEC 60529 standard	Permits unit installation in more severe environments	-0254-P1762
90-10 Copper-Nickel condensers	33	- Condenser tubes 90-10 Cu/Ni. - Condenser tube sheets clad with 90-10 Cu/Ni. - Waterboxes not treated against corrosion.	Improved resistance to corrosion	-0254-P1762
Unit supplied in two assembled parts	51	The unit is equipped with flanges that allow disassembly of the unit on site	Facilitates installation in plant rooms with limited access	-1652--1702, P1612-P1762
Master/slave operation	58	Unit equipped with supplementary water outlet temperature sensor kit (to be field installed) allowing master/slave operation of two units connected in parallel	Optimised operation of two units connected in parallel operation with operating time equalisation	-0254-P1762
Single power connection point	81	Unit power connection via one main supply connection	Quick and easy installation	-1002--1702, P1012-P1762
No disconnect switch	82A	Unit without disconnect switch, but with short-circuit protection device	Permits an external electrical disconnect system for the unit (field-supplied), while ensuring unit short circuit protection	-0254-P1762
Evap. single pump power/control circuit	84	Unit equipped with an electrical power and control circuit for one pump evaporator side	Quick and easy installation: the control of fixed speed pumps is embedded in the unit control	-0254--1252, P0512-P1314
Evap. dual pumps power/control circuit	84D	Unit equipped with an electrical power and control circuit for two pumps evaporator side	Quick and easy installation: the control of fixed speed pumps is embedded in the unit control	-0254--1252, P0512-P1314
Cond. single pump power/control circuit	84R	Unit equipped with an electrical power and control circuit for one pump condenser side	Quick and easy installation: the control of fixed speed pumps is embedded in the unit control	-0254--1252, P0512-P1314
Condenser insulation	86	Thermal condenser insulation	Minimizes thermal dispersions condenser side (key option for heat pump or heat recovery applications)	-0254-P1762
Service valve set	92	Liquid line valve (evaporator inlet) and compressor suction line valve	Allow isolation of various refrigerant circuit components for simplified service and maintenance	-0254-P1762
Evaporator with one pass less	100C	Evaporator with one pass on the water side. Evaporator inlet and outlet on opposite sides.	Easy to install, depending on site. Reduced pressure drops	-0254-P1762
Condenser with one pass less	102C	Condenser with one pass on the water side. Condenser inlet and outlet on opposite sides.	Easy to install, depending on site. Reduced pressure drops	-0254-P1762
21 bar evaporator	104	Reinforced evaporator for extension of the maximum water-side service pressure to 21 bar (standard 10 bar)	Covers applications with a high water column evaporator side (typically high buildings)	-0254-P1762
21 bar condenser	104A	Reinforced condenser for extension of the maximum water-side service pressure to 21 bar (standard 10 bar)	Covers applications with a high water column condenser side (typically high buildings)	-0254-P1762
Reversed evaporator water connections	107	Evaporator with reversed water inlet/outlet	Easy installation on sites with specific requirements	-0254-P1762
Reversed condenser water connections	107A	Condenser with reversed water inlet/outlet	Easy installation on sites with specific requirements	-0254-P1762
Lon gateway	148D	Bi-directional communication board complying with Lon Talk protocol	Connects the unit by communication bus to a building management system	-0254-P1762
Bacnet over IP	149	Bi-directional high-speed communication using BACnet protocol over Ethernet network (IP)	Easy and high-speed connection by ethernet line to a building management system. Allows access to multiple unit parameters	-0254-P1762
Modbus over IP and RS485	149B	Bi-directional high-speed communication using Modbus protocol over Ethernet network (IP)	Easy and high-speed connection by ethernet line to a building management system. Allows access to multiple unit parameters	-0254-P1762
High condensing temperature	150	Optimized compressor for operation at high condensing temperature	Increased condenser leaving water temperature up to 63°C. Allows applications with high condensing temperature (heat pumps, installations with not generously sized dry-coolers or more generally, installations with dry-coolers in hot climate). NOTE: to ens	-0254--0354, P0512-P1762

## OPTIONS

Options	No.	Description	Advantages	Use
Condensing temperature limitation	150B	Limitation of the maximum condenser leaving water temperature to 45°C	Reduced maximum power input and current absorption: power cables and protection elements can therefore be downsized	-0254-P1762
Control for low cond. temperature	152	Output signal (0-10 V) to control the condenser water inlet valve	Simple installation: for applications with cold water at condenser inlet (ex. ground-source, groundwater-source, superficial water-source applications) the signal permits to control a 2 or 3-way valve to maintain condenser water temperature (and so condensing pressure) at acceptable values	-0254-P1762
Dry-cooler control	154	Adaptation of the control box for communication with the dry-cooler via a bus. For dry cooler need to select the cabinet with option control cabinet manage by the chiller control	Easy system management, extended control capabilities of a remote dry-cooler	-0254-P1762
Energy Management Module	156	EMM Control board with additional inputs/outputs. See Energy Management Module option chapter	Extended remote control capabilities (Set-point reset, ice storage end, demand limits, boiler on/off command...)	-0254-P1762
7" user interface	158A	Control supplied with a 7 inch colour touch screen user interface	Enhanced ease of use.	-0254-P1762
Input contact for Refrigerant leak detection	159	0-10 V signal to report any refrigerant leakage in the unit directly on the controller (the leak detector itself must be supplied by the customer)	Immediate customer notification of refrigerant losses to the atmosphere, allowing timely corrective actions	-0254-P1762
Dual relief valves on 3-way valve	194	Three-way valve upstream of dual relief valves on the shell and tubes evaporator	Valve replacement and inspection facilitated without refrigerant loss. Comforms to European standard EN378/BGVD4	-0254-P1762
Compliance with Swiss regulations	197	Additional tests on the water heat exchangers: supply (additional of PED documents) supplementary certificates and test certifications	Conformance with Swiss regulations	-0254-P1762
Compliance with Russian regulations	199	EAC certification	Conformance with Russian regulations	-0254-P1762
Compliance with Australian regulations	200	Unit approved to Australian code	Conformance with Australian regulations	-0254-P1762
Low noise level	257	Evaporator sound insulation	3 dB(A) quieter than standard unit	-0402-P1762
Welded evaporator connection kit	266	Victaulic piping connections with welded joints	Easy installation	-0254-P1762
Welded condenser water connection kit	267	Victaulic piping connections with welded joints	Easy installation	-0254-P1762
Flanged evaporator water connection kit	268	Victaulic piping connections with flanged joints	Easy installation	-0254-P1762
Flanged condenser water connection kit	269	Victaulic piping connections with flanged joints	Easy installation	-0254-P1762
Thermal compressor insulation	271	The compressor is covered with a thermal insulation layer	Prevents air humidity to condensate on the compressor surface	-0254-P1762
230V electrical plug	284	230V AC power supply source provided with plug socket and transformer (180 VA, 0,8 Amps)	Permits connection of a laptop or an electrical device during unit commissioning or servicing	-0254-P1762
Free-cooling dry-cooler control	313	Control & connections to a Free Cooling Drycooler 09PE or 09VE fitted with option FC control box	Easy system management, Extended control capabilities to a drycooler used in Free Cooling mode	-0254-P1762
Compliance with UAE regulation	318	Additional label on the unit with rated power input, rated current and EER following AHRI 550/590	Compliance with ESMA standard UAE.S 5010-5:2019.	-0254-P1762
Compliance with Morocco regulation	327	Specifics documents according Morocco regulation	Conformance with Morocco regulations	-0254-P1762

## PHYSICAL DATA, STANDARD UNITS

### Standard-efficiency units

30XW--/30XWH-		254	304	354	402	452	552	602	652	702	802		
<b>Heating</b>													
<b>Standard unit Full load performances*</b>	HW1	Nominal capacity	kW	317	360	422	499	555	626	633	793	858	929
		COP	kW/kW	5,96	5,98	5,93	5,98	6,04	5,84	5,81	6,06	5,96	5,79
	HW2	Nominal capacity	kW	312	353	417	473	526	595	624	749	812	879
		COP	kW/kW	4,51	4,50	4,55	4,54	4,56	4,42	4,46	4,54	4,48	4,40
Seasonal energy efficiency**	HW1	SCOP <sub>30/35°C</sub>	kWh/kWh	5,98	6,02	5,99	6,45	6,60	6,58	6,31	6,16	6,15	6,13
		$\eta_s$ heat <sub>30/35°C</sub>	%	231	233	231	250	256	255	245	238	238	237
		P <sub>rated</sub>	kW	414	426	500	595	660	742	750	945	1022	1095
<b>Cooling</b>													
<b>Standard unit Full load performances*</b>	CW1	Nominal capacity	kW	269	303	354	421	467	525	531	669	720	783
		EER	kW/kW	5,25	5,23	5,17	5,22	5,28	5,12	5,11	5,32	5,23	5,13
	CW2	Nominal capacity	kW	264	320	396	525	566	520	596	753	788	782
		EER	kW/kW	7,30	5,74	6,31	6,50	6,40	5,24	5,86	6,02	5,76	5,22
Seasonal energy efficiency**		<b>SEER<sub>12/7°C</sub> Comfort low temp.</b>	<b>kWh/kWh</b>	<b>6,26</b>	<b>6,33</b>	<b>6,40</b>	<b>6,851</b>	<b>7,043</b>	<b>7,116</b>	<b>6,823</b>	<b>6,644</b>	<b>6,63</b>	<b>6,82</b>
		$\eta_s$ cool <sub>12/7°C</sub>	%	<b>247</b>	<b>250</b>	<b>253</b>	<b>271</b>	<b>279</b>	<b>282</b>	<b>270</b>	<b>263</b>	<b>262</b>	<b>270</b>
		SEPR <sub>12/7°C</sub> Process high temp.	kWh/kWh	8,60	8,16	8,80	8,12	8,28	7,72	7,90	8,83	8,25	8,01
Integrated Part Load Value	IPLV.SI	kW/kW	6,791	6,845	6,850	6,861	7,165	7,430	7,110	7,185	7,168	7,212	
<b>Sound levels - standard unit</b>													
Sound power level <sup>(1)</sup>		dB(A)	95	95	95	99	99	99	99	99	99	99	
Sound pressure level at 1 m <sup>(2)</sup>		dB(A)	78	78	78	82	82	82	82	82	82	82	
<b>Sound levels - standard unit + option 257<sup>(3)</sup></b>													
Sound power level <sup>(1)</sup>		dB(A)	-	-	-	96	96	96	96	96	96	96	
Sound pressure level at 1 m <sup>(2)</sup>		dB(A)	-	-	-	78	78	78	78	78	78	78	
<b>Dimensions - standard unit</b>													
Length		mm	2724	2724	2724	2741	2741	2741	2741	3059	3059	3059	
Width		mm	928	928	928	936	936	936	936	1040	1040	1040	
Height		mm	1567	1567	1567	1692	1692	1692	1692	1848	1848	1848	
Operating weight <sup>(4)</sup>		kg	2017	2036	2072	2575	2575	2613	2644	3247	3266	3282	
<b>Compressors</b>													
Semi-hermetic 06T screw compressors, 50 r/s													
Circuit A		-	1	1	1	1	1	1	1	1	1	1	
Circuit B		-	-	-	-	-	-	-	-	-	-	-	

\* In accordance with standard EN14511-3:2022.

\*\* In accordance with standard EN14825:2022, average climate

HW1 Heating mode conditions: Evaporator entering/leaving water temperature 10°C/7°C, condenser entering/leaving water temperature 30°C/35°C, evaporator and condenser fouling factor 0 m<sup>2</sup>. k/W

HW2 Heating mode conditions: Evaporator entering/leaving water temperature 10°C/7°C, condenser entering/leaving water temperature 40°C/45°C, evaporator and condenser fouling factor 0 m<sup>2</sup>. k/W

CW1 Cooling mode conditions: Evaporator water entering/leaving temperature 12°C/7°C, condenser entering/leaving water temperature 30°C/35°C, evaporator and condenser fouling factor 0 m<sup>2</sup>.K/W

CW2 Cooling mode conditions: Evaporator water entering/leaving temperature 23°C/18°C, condenser entering/leaving water temperature 30°C/35°C, evaporator and condenser fouling factor 0 m<sup>2</sup>.K/W

$\eta_s$  heat<sub>30/35°C</sub> & SCOP<sub>30/35°C</sub> Values calculated in accordance with EN14825:2022

$\eta_s$  cool<sub>12/7°C</sub> & SEER<sub>12/7°C</sub> **Bold values compliant to Ecodesign regulation: (EU) No 2016/2281 for Comfort application**

SEPR<sub>12/7°C</sub> Values calculated in accordance with EN14825:2022

IPLV.SI Calculations according to standard performances AHRI 551-591 (SI).

(1) In dB ref=10<sup>-12</sup> W, (A) weighting. Declared dualnumber noise emission values in accordance with ISO 4871 (with an associated uncertainty of +/-3dB(A)). Measured in accordance with ISO 9614-1 and certified by Eurovent.

(2) In dB ref 20μPa, (A) weighting. Declared dualnumber noise emission values in accordance with ISO 4871 (with an associated uncertainty of +/-3dB(A)). For information, calculated from the sound power level Lw(A).

(3) Option 257 = Low noise level.

(4) Weight shown is guideline only. Please refer to the unit nameplate.



Eurovent certified values



AHRI certified values  
30XW-only

## PHYSICAL DATA, STANDARD UNITS

### Standard-efficiency units

30XW--/30XWH-		254	304	354	402	452	552	602	652	702	802
<b>Refrigerant (4)</b>		R-134a									
Circuit A	kg	84	80	78	92	92	92	92	145	135	125
	teqCO <sub>2</sub>	120	114	112	132	132	132	132	207	193	179
Circuit B	kg	-	-	-	-	-	-	-	-	-	-
	teqCO <sub>2</sub>	-	-	-	-	-	-	-	-	-	-
<b>Oil - standard unit</b>											
Circuit A	l	23,5	23,5	23,5	32	32	32	32	36	36	36
Circuit B	l	-	-	-	-	-	-	-	-	-	-
<b>Capacity control</b>		SmartVu™, electronic expansion valves (EXV)									
Minimum capacity (5)	%	15	15	30	30	30	30	30	15	15	30
<b>Evaporator</b>		Multi-pipe flooded type									
Water volume	l	50	56	61	70	70	70	70	109	109	109
Water connections (Victaulic)	in	5	5	5	5	5	5	5	6	6	6
Drain and vent connections (NPT)	in	3/8	3/8	3/8	3/8	3/8	3/8	3/8	3/8	3/8	3/8
Max. water-side operating pressure	kPa	1000	1000	1000	1000	1000	1000	1000	1000	1000	1000
<b>Condenser</b>		Multi-pipe flooded type									
Water volume	l	55	55	55	76	76	76	76	109	109	109
Water connections (Victaulic)	in	5	5	5	5	5	5	5	6	6	6
Drain and vent connections (NPT)	in	3/8	3/8	3/8	3/8	3/8	3/8	3/8	3/8	3/8	3/8
Max. water-side operating pressure	kPa	1000	1000	1000	1000	1000	1000	1000	1000	1000	1000

(4) Weight shown is guideline only. Please refer to the unit nameplate.

(5) Minimum unit capacity corresponds to a physical state of the unit and is given for indication only. The actual capacity at this stage depends on operating conditions.

## PHYSICAL DATA, STANDARD UNITS

### Standard-efficiency units

30XWH--/30XWH-		852	1002	1052	1154	1252	1352	1452	1552	1652	1702			
<b>Heating</b>														
<b>Standard unit Full load performances*</b>	HW1	Nominal capacity	kW		981	1185	1237	1324	1457	1557	1689	1795	1913	2001
		COP	kW/kW		5,98	5,77	5,67	5,79	6,12	5,96	5,76	5,61	5,94	5,92
	HW2	Nominal capacity	kW		958	1123	1174	1297	1375	1466	1592	1687	1867	1948
		COP	kW/kW		4,60	4,40	4,33	4,46	4,63	4,53	4,41	4,33	4,61	4,64
Seasonal energy efficiency**	HW1	SCOP <sub>30/35°C</sub>	kWh/kWh		6,33	6,43	6,24	6,30	6,56	6,33	6,22	6,11	6,46	6,50
		η <sub>s heat 30/35°C</sub>	%		245	249	242	244	254	245	241	236	251	252
		P <sub>rated</sub>	kW		1153	1411	1473	1569	1737	1856	2013	2140	2265	2371
<b>Cooling</b>														
<b>Standard unit Full load performances*</b>	CW1	Nominal capacity	kW		829	1005	1049	1128	1242	1327	1438	1532	1637	1712
		EER	kW/kW		5,33	5,19	5,12	5,25	5,55	5,45	5,31	5,24	5,54	5,55
	CW2	Nominal capacity	kW		828	1188	1322	1220	1535	1677	1753	1865	1726	1830
		EER	kW/kW		5,43	6,93	6,30	5,75	6,72	6,71	6,30	6,36	5,95	5,91
Seasonal energy efficiency**		<b>SEER<sub>12/7°C</sub> Comfort low temp.</b>	<b>kWh/kWh</b>		<b>7,091</b>	<b>7,07</b>	<b>7,02</b>	<b>6,96</b>	<b>7,51</b>	<b>7,24</b>	<b>7,11</b>	<b>7,13</b>	<b>7,55</b>	<b>7,69</b>
		η <sub>s cool 12/7°C</sub>	%		<b>281</b>	<b>280</b>	<b>278</b>	<b>275</b>	<b>298</b>	<b>287</b>	<b>282</b>	<b>282</b>	<b>299</b>	<b>304</b>
		SEPR <sub>12/7°C</sub> Process high temp.	kWh/kWh		8,01	8,29	8,11	7,96	8,97	9,09	8,34	8,13	8,45	8,50
Integrated Part Load Value	IPLV.SI	kW/kW		7,289	7,478	7,367	7,435	7,804	7,725	7,666	7,504	8,000	8,020	
<b>Sound levels - standard unit</b>														
Sound power level <sup>(1)</sup>	dB(A)		99	102	102	102	102	102	102	102	102	102	102	
Sound pressure level at 1 m <sup>(2)</sup>	dB(A)		82	84	84	84	83	83	83	83	83	83	83	
<b>Sound levels - standard unit + option 257<sup>(3)</sup></b>														
Sound power level <sup>(1)</sup>	dB(A)		96	99	99	99	99	99	99	99	99	99	99	
Sound pressure level at 1 m <sup>(2)</sup>	dB(A)		78	80	80	80	80	80	80	80	80	80	80	
<b>Dimensions - standard unit</b>														
Length	mm		2780	4025	4025	4025	4730	4730	4730	4730	4730	4790	4790	
Width	mm		1042	1036	1036	1036	1156	1156	1156	1156	1156	1902	1902	
Height	mm		1898	1870	1870	1925	2051	2051	2051	2051	2051	1515	1515	
Operating weight <sup>(4)</sup>	kg		3492	5370	5408	5698	7066	7267	7305	7337	8681	8699		
<b>Compressors</b>														
Semi-hermetic 06T screw compressors, 50 r/s														
Circuit A	-		1	1	1	1	1	1	1	1	1	1		
Circuit B	-		-	1	1	1	1	1	1	1	1	1		

\* In accordance with standard EN14511-3:2022.

\*\* In accordance with standard EN14825:2022, average climate

HW1 Heating mode conditions: Evaporator entering/leaving water temperature 10°C/7°C, condenser entering/leaving water temperature 30°C/35°C, evaporator and condenser fouling factor 0 m<sup>2</sup>. k/W

HW2 Heating mode conditions: Evaporator entering/leaving water temperature 10°C/7°C, condenser entering/leaving water temperature 40°C/45°C, evaporator and condenser fouling factor 0 m<sup>2</sup>. k/W

CW1 Cooling mode conditions: Evaporator water entering/leaving temperature 12°C/7°C, condenser entering/leaving water temperature 30°C/35°C, evaporator and condenser fouling factor 0 m<sup>2</sup>.K/W

CW2 Cooling mode conditions: Evaporator water entering/leaving temperature 23°C/18°C, condenser entering/leaving water temperature 30°C/35°C, evaporator and condenser fouling factor 0 m<sup>2</sup>.K/W

η<sub>s heat 30/35°C</sub> & SCOP<sub>30/35°C</sub> Values calculated in accordance with EN14825:2022

η<sub>s cool 12/7°C</sub> & SEER<sub>12/7°C</sub> **Bold values compliant to Ecodesign regulation: (EU) No 2016/2281 for Comfort application**

SEPR<sub>12/7°C</sub> Values calculated in accordance with EN14825:2022

IPLV.SI Calculations according to standard performances AHRI 551-591 (SI).

(1) In dB ref=10<sup>-12</sup> W, (A) weighting. Declared dualnumber noise emission values in accordance with ISO 4871 (with an associated uncertainty of +/-3dB(A)). Measured in accordance with ISO 9614-1 and certified by Eurovent.

(2) In dB ref 20μPa, (A) weighting. Declared dualnumber noise emission values in accordance with ISO 4871 (with an associated uncertainty of +/-3dB(A)). For information, calculated from the sound power level Lw(A).

(3) Option 257 = Low noise level.

(4) Weight shown is guideline only. Please refer to the unit nameplate.



Eurovent certified values



AHRI certified values  
30XW-only



## PHYSICAL DATA, STANDARD UNITS

### Standard-efficiency units

30XW--/30XWH-		852	1002	1052	1154	1252	1352	1452	1552	1652	1702
<b>Refrigerant (4)</b>		R-134a									
Circuit A	kg	158	85	85	105	120	115	110	105	195	195
	teqCO <sub>2</sub>	226	122	122	150	172	164	157	150	279	279
Circuit B	kg	-	85	85	105	120	115	110	105	195	195
	teqCO <sub>2</sub>	-	122	122	150	172	164	157	150	279	279
<b>Oil - standard unit</b>											
Circuit A	l	36	32	32	32	36	36	36	36	36	36
Circuit B	l	-	32	32	32	32	36	36	36	36	36
<b>Capacity control</b>		SmartVu™, electronic expansion valves (EXV)									
Minimum capacity (5)	%	30	30	30	30	15	15	15	30	30	30
<b>Evaporator</b>		Multi-pipe flooded type									
Water volume	l	98	182	182	205	301	301	301	301	354	354
Water connections (Victaulic)	in	6	6	6	8	8	8	8	8	8	8
Drain and vent connections (NPT)	in	3/8	3/8	3/8	3/8	3/8	3/8	3/8	3/8	3/8	3/8
Max. water-side operating pressure	kPa	1000	1000	1000	1000	1000	1000	1000	1000	1000	1000
<b>Condenser</b>		Multi-pipe flooded type									
Water volume	l	137	193	193	193	340	340	340	340	426	426
Water connections (Victaulic)	in	8	8	8	8	8	8	8	8	8	8
Drain and vent connections (NPT)	in	3/8	3/8	3/8	3/8	3/8	3/8	3/8	3/8	3/8	3/8
Max. water-side operating pressure	kPa	1000	1000	1000	1000	1000	1000	1000	1000	1000	1000

(4) Weight shown is guideline only. Please refer to the unit nameplate.

(5) Minimum unit capacity corresponds to a physical state of the unit and is given for indication only. The actual capacity at this stage depends on operating conditions.

## PHYSICAL DATA, STANDARD UNITS

### High-efficiency units

30XW-P/30XWHP			512	562	712	812	862	1012	1162	1314	1464	1612	1762	
<b>Heating</b>														
<b>Standard unit Full load performances*</b>	HW1	Nominal capacity	kW	586	667	851	912	995	1201	1327	1522	1680	1863	2019
		COP	kW/kW	6,36	6,30	6,52	6,29	6,27	6,35	6,24	6,29	6,06	6,38	6,27
	HW2	Nominal capacity	kW	573	654	836	896	970	1179	1296	1489	1643	1823	1964
		COP	kW/kW	4,82	4,78	4,92	4,74	4,78	4,85	4,77	4,82	4,66	4,84	4,81
Seasonal energy efficiency**	HW1	SCOP <sub>30/35°C</sub>	kWh/kWh	6,58	6,59	6,48	6,27	6,48	6,72	6,85	6,75	6,38	6,73	6,71
		η <sub>s heat</sub> <sub>30/35°C</sub>	%	255	256	251	243	251	261	266	262	247	261	260
		P <sub>rated</sub>	kW	694	791	1009	1081	1180	1424	1572	1805	1993	2210	2395
<b>Cooling</b>														
<b>Standard unit Full load performances*</b>	CW1	Nominal capacity	kW	502	569	727	776	850	1025	1143	1308	1435	1606	1736
		EER	kW/kW	5,63	5,57	5,75	5,55	5,59	5,67	5,71	5,74	5,53	5,80	5,72
	CW2	Nominal capacity	kW	546	643	788	859	886	1217	1251	1554	1687	1802	1865
		EER	kW/kW	6,36	6,38	6,62	6,44	6,28	7,29	6,30	8,19	6,69	6,75	6,54
Seasonal energy efficiency**		<b>SEER<sub>12/7°C</sub> Comfort low temp.</b>	<b>kWh/kWh</b>	<b>7,00</b>	<b>7,12</b>	<b>7,05</b>	<b>6,82</b>	<b>7,24</b>	<b>7,34</b>	<b>7,78</b>	<b>7,69</b>	<b>7,29</b>	<b>7,79</b>	<b>7,86</b>
		η <sub>s cool</sub> <sub>12/7°C</sub>	%	<b>277</b>	<b>282</b>	<b>279</b>	<b>270</b>	<b>287</b>	<b>291</b>	<b>308</b>	<b>304</b>	<b>289</b>	<b>309</b>	<b>311</b>
		SEPR <sub>12/7°C</sub> Process high temp.	kWh/kWh	8,42	8,50	9,23	8,33	8,54	8,50	8,85	9,00	8,89	8,82	8,83
Integrated Part Load Value	IPLV.SI	kW/kW	7,391	7,473	7,556	7,301	7,538	7,639	8,053	8,150	7,485	7,757	8,089	
<b>Sound levels - standard unit</b>														
Sound power level (1)		dB(A)	99	99	99	99	99	102	102	102	102	102	102	
Sound pressure level at 1 m (2)		dB(A)	82	82	81	81	81	83	83	83	83	83	83	
<b>Sound levels - standard unit + option 257(3)</b>														
Sound power level (1)		dB(A)	96	96	96	96	96	99	99	99	99	99	99	
Sound pressure level at 1 m (2)		dB(A)	78	78	78	78	78	80	80	80	80	80	80	
<b>Dimensions - standard unit</b>														
Length		mm	3059	3059	3290	3290	3290	4730	4730	4730	4730	4832	4832	
Width		mm	936	936	1069	1069	1069	1039	1039	1162	1162	2129	2129	
Height		mm	1743	1743	1950	1950	1950	1997	1997	2051	2051	1562	1562	
Operating weight (4)		kg	2981	3020	3912	3947	3965	6872	6950	7542	7752	10910	10946	
<b>Compressors</b>														
Semi-hermetic 06T screw compressors, 50 r/s														
Circuit A		-	1	1	1	1	1	1	1	1	1	1	1	
Circuit B		-	-	-	-	-	-	1	1	1	1	1	1	

\* In accordance with standard EN14511-3:2022.  
 \*\* In accordance with standard EN14825:2022, average climate  
 HW1 Heating mode conditions: Evaporator entering/leaving water temperature 10°C/7°C, condenser entering/leaving water temperature 30°C/35°C, evaporator and condenser fouling factor 0 m<sup>2</sup>. k/W  
 HW2 Heating mode conditions: Evaporator entering/leaving water temperature 10°C/7°C, condenser entering/leaving water temperature 40°C/45°C, evaporator and condenser fouling factor 0 m<sup>2</sup>. k/W  
 CW1 Cooling mode conditions: Evaporator water entering/leaving temperature 12°C/7°C, condenser entering/leaving water temperature 30°C/35°C, evaporator and condenser fouling factor 0 m<sup>2</sup>.K/W  
 CW2 Cooling mode conditions: Evaporator water entering/leaving temperature 23°C/18°C, condenser entering/leaving water temperature 30°C/35°C, evaporator and condenser fouling factor 0 m<sup>2</sup>.K/W  
 η<sub>s heat</sub><sub>30/35°C</sub> & SCOP<sub>30/35°C</sub> Values calculated in accordance with EN14825:2022  
 η<sub>s cool</sub><sub>12/7°C</sub> & SEER<sub>12/7°C</sub> **Bold values compliant to Ecodesign regulation: (EU) No 2016/2281 for Comfort application**  
 SEPR<sub>12/7°C</sub> Values calculated in accordance with EN14825:2022  
 IPLV.SI Calculations according to standard performances AHRI 551-591 (SI).  
 (1) In dB ref=10<sup>-12</sup> W, (A) weighting. Declared dualnumber noise emission values in accordance with ISO 4871 (with an associated uncertainty of +/-3dB(A)). Measured in accordance with ISO 9614-1 and certified by Eurovent.  
 (2) In dB ref 20μPa, (A) weighting. Declared dualnumber noise emission values in accordance with ISO 4871 (with an associated uncertainty of +/-3dB(A)). For information, calculated from the sound power level Lw(A).  
 (3) Option 257 = Low noise level.  
 (4) Weight shown is guideline only. Please refer to the unit nameplate.



Eurovent certified values



AHRI certified values 30XW-only



## PHYSICAL DATA, STANDARD UNITS

### High-efficiency units

30XW-P/30XWHP		512	562	712	812	862	1012	1162	1314	1464	1612	1762
<b>Refrigerant <sup>(4)</sup></b>		R-134a										
Circuit A	kg	130	130	180	175	177	120	120	130	130	240	250
	teqCO <sub>2</sub>	186	186	257	250	253	172	172	186	186	343	358
Circuit B	kg	-	-	-	-	-	120	120	150	130	240	250
	teqCO <sub>2</sub>	-	-	-	-	-	172	172	215	186	343	358
<b>Oil - standard unit</b>												
Circuit A	l	32	32	36	36	36	32	32	36	36	36	36
Circuit B	l	-	-	-	-	-	32	32	32	36	36	36
<b>Capacity control</b>		SmartVu™, electronic expansion valves (EXV)										
Minimum capacity <sup>(5)</sup>	%	30	30	15	15	30	30	30	15	15	15	30
<b>Evaporator</b>		Multi-pipe flooded type										
Water volume	l	101	101	154	154	154	293	293	321	321	473	473
Water connections (Victaulic)	in	6	6	8	8	8	8	8	8	8	10	10
Drain and vent connections (NPT)	in	3/8	3/8	3/8	3/8	3/8	3/8	3/8	3/8	3/8	3/8	3/8
Max. water-side operating pressure	kPa	1000	1000	1000	1000	1000	1000	1000	1000	1000	1000	1000
<b>Condenser</b>		Multi-pipe flooded type										
Water volume	l	103	103	148	148	148	316	316	340	340	623	623
Water connections (Victaulic)	in	6	6	8	8	8	8	8	8	8	10	10
Drain and vent connections (NPT)	in	3/8	3/8	3/8	3/8	3/8	3/8	3/8	3/8	3/8	3/8	3/8
Max. water-side operating pressure	kPa	1000	1000	1000	1000	1000	1000	1000	1000	1000	1000	1000

(4) Weight shown is guideline only. Please refer to the unit nameplate.

(5) Minimum unit capacity corresponds to a physical state of the unit and is given for indication only. The actual capacity at this stage depends on operating conditions.

## ELECTRICAL DATA, STANDARD UNITS

### Standard-efficiency units

30XWH--/30XWH-		254	304	354	402	452	552	602	652	702	802
<b>Power circuit</b>											
Nominal power supply	V-ph-Hz	400-3-50									
Voltage range	V	360-440									
<b>Control circuit</b>											
24 V via the built-in transformer											
<b>Nominal start-up current (1)</b>											
Circuit A	A	233	233	303	414	414	414	414	587	587	587
Circuit B	A	-	-	-	-	-	-	-	-	-	-
Option 81	A	-	-	-	-	-	-	-	-	-	-
<b>Maximum start-up current (2)</b>											
Circuit A	A	233	233	303	414	414	414	414	587	587	587
Circuit B	A	-	-	-	-	-	-	-	-	-	-
Option 81	A	-	-	-	-	-	-	-	-	-	-
<b>Cosine phi</b>											
Nominal (3)		0,83	0,85	0,83	0,87	0,88	0,89	0,89	0,88	0,89	0,90
Maximum (4)		0,89	0,89	0,88	0,90	0,90	0,91	0,91	0,90	0,91	0,92
Total harmonic distortion (4)	%	0	0	0	0	0	0	0	0	0	0
<b>Maximum power input†</b>											
Circuit A	kW	76	89	97	128	135	151	151	184	200	223
Circuit B	kW	-	-	-	-	-	-	-	-	-	-
Option 81	kW	-	-	-	-	-	-	-	-	-	-
<b>Nominal current drawn (3)</b>											
Circuit A	A	84	96	113	136	144	162	162	193	214	232
Circuit B	A	-	-	-	-	-	-	-	-	-	-
Option 81	A	-	-	-	-	-	-	-	-	-	-
<b>Maximum current drawn (Un)†</b>											
Circuit A	A	123	145	160	206	217	242	242	295	317	351
Circuit B	A	-	-	-	-	-	-	-	-	-	-
Option 81	A	-	-	-	-	-	-	-	-	-	-
<b>Maximum current drawn (Un -10%) (4)</b>											
Circuit A	A	138	162	178	218	230	260	260	304	340	358
Circuit B	A	-	-	-	-	-	-	-	-	-	-
Option 81	A	-	-	-	-	-	-	-	-	-	-
<b>Maximum power input with option 150B†</b>											
Circuit A	kW	67	79	87	114	118	133	134	173	183	205
Circuit B	kW	-	-	-	-	-	-	-	-	-	-
Option 81	kW	-	-	-	-	-	-	-	-	-	-
<b>Maximum current drawn (Un) with option 150B†</b>											
Circuit A	A	109	129	142	183	191	212	212	278	290	325
Circuit B	A	-	-	-	-	-	-	-	-	-	-
Option 81	A	-	-	-	-	-	-	-	-	-	-

(1) Instantaneous start-up current (maximum operating current of the smallest compressor(s) + locked rotor current or reduced start-up current of the largest compressor). Values obtained at standard Eurovent unit operating conditions: evaporator entering/leaving water temperature = 12°C/7°C, condenser entering/leaving water temperature = 30°C/35°C.

(2) Instantaneous start-up current (maximum operating current of the smallest compressor(s) + locked rotor current or reduced start-up current of the largest compressor). Values obtained at operation with maximum unit power input.

(3) Values obtained at standard Eurovent unit operating conditions: evaporator entering/leaving water temperature = 12°C/7°C, condenser entering/leaving water temperature = 30°C/35°C.

(4) Values obtained at operation with maximum unit power input.

† Values obtained at operation with maximum unit power input. Values given on the unit name plate.

## ELECTRICAL DATA, STANDARD UNITS

### Standard-efficiency units

30XWH--/30XWH-		852	1002	1052	1154	1252	1352	1452	1552	1652	1702
<b>Power circuit</b>											
Nominal power supply	V-ph-Hz	400-3-50									
Voltage range	V	360-440									
<b>Control circuit</b>											
24 V via the built-in transformer											
<b>Nominal start-up current (1)</b>											
Circuit A	A	587	414	414	414	587	587	587	587	587	587
Circuit B	A	-	414	414	414	414	587	587	587	587	587
Option 81	A	-	558	574	574	747	780	801	819	819	819
<b>Maximum start-up current (2)</b>											
Circuit A	A	587	414	414	414	587	587	587	587	587	587
Circuit B	A	-	414	414	414	414	587	587	587	587	587
Option 81	A	-	631	656	656	829	882	904	938	938	938
<b>Cosine phi</b>											
Nominal (3)		0,90	0,88	0,89	0,89	0,88	0,88	0,89	0,9	0,9	0,9
Maximum (4)		0,92	0,90	0,91	0,91	0,90	0,90	0,91	0,92	0,92	0,92
Total harmonic distortion (4)	%	0	0	0	0	0	0	0	0	0	0
<b>Maximum power input†</b>											
Circuit A	kW	223	150	151	151	184	184	200	223	223	223
Circuit B	kW	-	135	151	151	151	184	200	223	202	223
Option 81	kW	-	284	301	301	334	367	399	447	425	447
<b>Nominal current drawn (3)</b>											
Circuit A	A	232	162	162	162	193	193	214	232	232	232
Circuit B	A	-	144	162	162	162	193	214	232	214	232
Option 81	A	-	306	324	324	355	386	427	464	446	464
<b>Maximum current drawn (Un)†</b>											
Circuit A	A	351	242	242	242	295	295	317	351	351	351
Circuit B	A	-	217	242	242	242	295	317	351	317	351
Option 81	A	-	459	484	484	537	590	634	702	668	702
<b>Maximum current drawn (Un -10%) (4)</b>											
Circuit A	A	358	260	260	260	304	304	340	358	358	358
Circuit B	A	-	230	260	260	260	304	340	358	340	358
Option 81	A	-	490	520	520	564	608	680	716	698	716
<b>Maximum power input with option 150B†</b>											
Circuit A	kW	205	133	133	133	173	173	183	207	207	207
Circuit B	kW	-	118	133	133	133	173	183	207	185	207
Option 81	kW	-	251	265	265	305	346	365	414	391	414
<b>Maximum current drawn (Un) with option 150B†</b>											
Circuit A	A	325	212	212	212	278	278	290	325	325	325
Circuit B	A	-	191	212	212	212	278	290	325	290	325
Option 81	A	-	403	424	424	490	556	580	650	615	650

(1) Instantaneous start-up current (maximum operating current of the smallest compressor(s) + locked rotor current or reduced start-up current of the largest compressor). Values obtained at standard Eurovent unit operating conditions: evaporator entering/leaving water temperature = 12°C/7°C, condenser entering/leaving water temperature = 30°C/35°C.

(2) Instantaneous start-up current (maximum operating current of the smallest compressor(s) + locked rotor current or reduced start-up current of the largest compressor). Values obtained at operation with maximum unit power input.

(3) Values obtained at standard Eurovent unit operating conditions: evaporator entering/leaving water temperature = 12°C/7°C, condenser entering/leaving water temperature = 30°C/35°C

(4) Values obtained at operation with maximum unit power input.

† Values obtained at operation with maximum unit power input. Values given on the unit name plate.



## ELECTRICAL DATA, STANDARD UNITS

### High-efficiency units

30XW-P/30XWHP		512	562	712	812	862	1012	1162	1314	1464	1612	1762
<b>Power circuit</b>												
Nominal power supply	V-ph-Hz	400-3-50										
Voltage range	V	360-440										
<b>Control circuit</b>												
24 V via the built-in transformer												
<b>Nominal start-up current <sup>(1)</sup></b>												
Circuit A	A	414	414	587	587	587	414	414	587	587	587	587
Circuit B	A	-	-	-	-	-	414	414	414	587	587	587
Option 81	A	-	-	-	-	-	556	574	747	780	801	819
<b>Maximum start-up current <sup>(2)</sup></b>												
Circuit A	A	414	414	587	587	587	414	414	587	587	587	587
Circuit B	A	-	-	-	-	-	414	414	414	587	587	587
Option 81	A	-	-	-	-	-	631	656	829	882	904	938
<b>Cosine phi</b>												
Nominal <sup>(3)</sup>		0,88	0,89	0,88	0,89	0,90	0,86	0,87	0,88	0,88	0,89	0,90
Maximum <sup>(4)</sup>		0,90	0,90	0,90	0,91	0,92	0,89	0,90	0,90	0,90	0,91	0,92
Total harmonic distortion <sup>(4)</sup>	%	0	0	0	0	0	0	0	0	0	0	0
<b>Maximum power input†</b>												
Circuit A	kW	135	151	184	200	223	134	151	184	184	200	223
Circuit B	kW	-	-	-	-	-	134	151	151	184	200	223
Option 81	kW	-	-	-	-	-	267	301	334	367	399	447
<b>Nominal current drawn <sup>(3)</sup></b>												
Circuit A	A	144	162	193	214	232	144	162	193	193	214	232
Circuit B	A	-	-	-	-	-	144	162	162	193	214	232
Option 81	A	-	-	-	-	-	288	324	355	386	427	464
<b>Maximum current drawn (Un)†</b>												
Circuit A	A	217	242	295	317	351	217	242	295	295	317	351
Circuit B	A	-	-	-	-	-	217	242	242	295	317	351
Option 81	A	-	-	-	-	-	434	484	537	590	634	702
<b>Maximum current drawn (Un -10%) <sup>(4)</sup></b>												
Circuit A	A	230	260	304	340	358	230	260	304	304	340	358
Circuit B	A	-	-	-	-	-	230	260	260	304	340	358
Option 81	A	-	-	-	-	-	460	520	564	608	680	716
<b>Maximum power input with option 150B†</b>												
Circuit A	kW	118	133	173	183	207	118	133	173	173	183	207
Circuit B	kW	-	-	-	-	-	118	133	133	173	183	207
Option 81	kW	-	-	-	-	-	235	265	305	346	365	414
<b>Maximum current drawn (Un) with option 150B†</b>												
Circuit A	A	191	212	278	290	325	191	212	278	278	290	325
Circuit B	A	-	-	-	-	-	191	212	212	278	290	325
Option 81	A	-	-	-	-	-	382	424	490	556	580	650

(1) Instantaneous start-up current (maximum operating current of the smallest compressor(s) + locked rotor current or reduced start-up current of the largest compressor). Values obtained at standard Eurovent unit operating conditions: evaporator entering/leaving water temperature = 12°C/7°C, condenser entering/leaving water temperature = 30°C/35°C.

(2) Instantaneous start-up current (maximum operating current of the smallest compressor(s) + locked rotor current or reduced start-up current of the largest compressor). Values obtained at operation with maximum unit power input.

(3) Values obtained at standard Eurovent unit operating conditions: evaporator entering/leaving water temperature = 12°C/7°C, condenser entering/leaving water temperature = 30°C/35°C.

(4) Values obtained at operation with maximum unit power input.

† Values obtained at operation with maximum unit power input. Values given on the unit name plate.

# PHYSICAL DATA, UNITS FOR HIGH CONDENSING TEMPERATURES

## Standard-efficiency units (option 150)

30XWH--/30XWH-	254	304	354	402	452	552	602	652	702	802
----------------	-----	-----	-----	-----	-----	-----	-----	-----	-----	-----

### Heating

Unit + option 150 Full load performances*	HW1	Nominal capacity	kW	328	366	413	502	536	597	618	756	845	869
		COP	kW/kW	5,49	5,48	5,44	5,11	5,41	5,27	5,41	5,31	5,37	5,17
	HW2	Nominal heating capacity	kW	319	356	402	470	501	559	599	706	789	812
		COP	kW/kW	4,54	4,51	4,47	4,21	4,45	4,36	4,48	4,39	4,44	4,31
	HW3	Nominal capacity	kW	310	347	391	440	469	523	582	659	738	760
		COP	kW/kW	3,80	3,78	3,75	3,47	3,67	3,61	3,76	3,62	3,68	3,57
Seasonal energy efficiency**	HW1	SCOP <sub>30/35°C</sub>	kWh/kWh	5,77	5,94	5,86	5,54	5,77	5,75	5,72	5,55	5,79	5,01
		η <sub>s heat</sub> <sub>30/35°C</sub>	%	223	230	226	214	223	222	221	214	223	193
		SCOP <sub>47/55°C</sub>	kWh/kWh	4,58	4,63	4,56	4,20	4,42	4,45	4,50	4,26	4,45	3,86
	HW3	η <sub>s heat</sub> <sub>47/55°C</sub>	%	175	177	175	160	169	170	172	163	170	146
		P <sub>rated</sub>	kW	411	415	467	535	571	637	697	803	898	926

### Cooling

Unit + option 150 Full load performances*	CW1	Nominal cooling capacity	kW	278	309	348	NA	NA	NA	NA	NA	NA	NA
		EER	kW/kW	4,83	4,80	4,76	NA	NA	NA	NA	NA	NA	NA
Seasonal energy efficiency**		SEER <sub>12/7°C</sub> Comfort low temp.	kWh/kWh	<b>6,19</b>	<b>6,29</b>	<b>6,22</b>	NA	NA	NA	NA	NA	NA	NA
		η <sub>s cool</sub> <sub>12/7°C</sub>	%	<b>245</b>	<b>249</b>	<b>246</b>	NA	NA	NA	NA	NA	NA	NA
		SEPR <sub>12/7°C</sub> Process high temp.	kWh/kWh	6,67	6,72	6,57	NA	NA	NA	NA	NA	NA	NA
Integrated Part Load Value	IPLV.SI	kW/kW	6,364	6,527	6,531	5,928	6,176	6,287	6,185	5,931	6,433	5,575	

### Sound levels - unit with option 150

Sound power level <sup>(1)</sup>	dB(A)	95	95	95	99	99	99	99	99	102	102	102
Sound pressure level at 1 m <sup>(2)</sup>	dB(A)	78	78	78	82	82	82	82	82	84	84	84

### Sound levels - unit with option 150 + option 257<sup>(3)</sup>

Sound power level <sup>(1)</sup>	dB(A)	-	-	-	96	96	96	96	96	100	100	100
Sound pressure level at 1 m <sup>(2)</sup>	dB(A)	-	-	-	78	78	78	78	78	82	82	82

### Dimensions - unit with option 150

Length	mm	2724	2724	2724	2741	2741	2741	2741	2741	3059	3059	3059
Width	mm	928	928	928	936	936	936	936	936	1090	1090	1090
Height	mm	1567	1567	1567	1692	1692	1692	1692	1692	1858	1858	1858

### Operating weight<sup>(4)</sup>

Compressors		Semi-hermetic 06T screw compressors, 50 r/s										
Circuit A	-	1	1	1	1	1	1	1	1	1	1	1
Circuit B	-	-	-	-	-	-	-	-	-	-	-	-

\* In accordance with standard EN14511-3:2022.  
 \*\* In accordance with standard EN14825:2022, average climate  
 HW1 Heating mode conditions: Evaporator entering/leaving water temperature 10°C/7°C, condenser entering/leaving water temperature 30°C/35°C, evaporator and condenser fouling factor 0 m<sup>2</sup>. k/W  
 HW2 Heating mode conditions: Evaporator entering/leaving water temperature 10°C/7°C, condenser entering/leaving water temperature 40°C/45°C, evaporator and condenser fouling factor 0 m<sup>2</sup>. k/W  
 HW3 Heating mode conditions: Evaporator entering/leaving water temperature 10°C/7°C, condenser entering/leaving water temperature 47°C/55°C, evaporator and condenser fouling factor 0 m<sup>2</sup>. k/W  
 CW1 Cooling mode conditions: Evaporator water entering/leaving temperature 12°C/7°C, condenser entering/leaving water temperature 30°C/35°C, evaporator and condenser fouling factor 0 m<sup>2</sup>. K/W  
 η<sub>s heat</sub> <sub>30/35°C</sub> & SCOP<sub>30/35°C</sub> Values calculated in accordance with EN14825:2022  
 η<sub>s heat</sub> <sub>47/55°C</sub> & SCOP<sub>47/55°C</sub> Values calculated in accordance with EN14825:2022  
 η<sub>s cool</sub> <sub>12/7°C</sub> & SEER<sub>12/7°C</sub> **Bold values compliant to Ecodesign regulation: (EU) No 2016/2281 for Comfort application**  
 SEPR<sub>12/7°C</sub> Values calculated in accordance with EN14825:2022  
 IPLV.SI Calculations according to standard performances AHRI 551-591 (SI).  
 NA Non Authorized for the specific application for CEE market  
 (1) In dB ref=10<sup>-12</sup> W, (A) weighting. Declared dualnumber noise emission values in accordance with ISO 4871 (with an associated uncertainty of +/-3dB(A)). Measured in accordance with ISO 9614-1 and certified by Eurovent.  
 (2) In dB ref 20μPa, (A) weighting. Declared dualnumber noise emission values in accordance with ISO 4871 (with an associated uncertainty of +/-3dB(A)). For information, calculated from the sound power level Lw(A).  
 (3) Option 257 = Low noise level  
 (4) Weight shown is guideline only. Please refer to the unit nameplate



Eurovent certified values



AHRI certified values  
30XW-only

## PHYSICAL DATA, UNITS FOR HIGH CONDENSING TEMPERATURES

### Standard-efficiency units (option 150)

30XW--/30XWH-		254	304	354	402	452	552	602	652	702	802
<b>Refrigerant <sup>(4)</sup></b>		R-134a									
Circuit A	kg	84	80	78	92	92	92	92	145	135	125
	teqCO <sub>2</sub>	120	114	112	132	132	132	132	207	193	179
Circuit B	kg	-	-	-	-	-	-	-	-	-	-
	teqCO <sub>2</sub>	-	-	-	-	-	-	-	-	-	-
<b>Oil - unit with option 150</b>											
Circuit A	l	23,5	23,5	23,5	32	32	32	32	36	36	36
Circuit B	l	-	-	-	-	-	-	-	-	-	-
<b>Capacity control</b>		SmartVu™, electronic expansion valves (EXV)									
Minimum capacity <sup>(5)</sup>	%	30	30	30	30	30	30	30	25	25	25
<b>Evaporator</b>		Multi-pipe flooded type									
Water volume	l	50	56	61	70	70	70	70	109	109	109
Water connections (Victaulic)	in	5	5	5	5	5	5	5	6	6	6
Drain and vent connections (NPT)	in	3/8	3/8	3/8	3/8	3/8	3/8	3/8	3/8	3/8	3/8
Max. water-side operating pressure	kPa	1000	1000	1000	1000	1000	1000	1000	1000	1000	1000
<b>Condenser</b>		Multi-pipe flooded type									
Water volume	l	55	55	55	76	76	76	76	109	109	109
Water connections (Victaulic)	in	5	5	5	5	5	5	5	6	6	6
Drain and vent connections (NPT)	in	3/8	3/8	3/8	3/8	3/8	3/8	3/8	3/8	3/8	3/8
Max. water-side operating pressure	kPa	1000	1000	1000	1000	1000	1000	1000	1000	1000	1000

(4) Weight shown is guideline only. Please refer to the unit nameplate

(5) Minimum unit capacity corresponds to a physical state of the unit and is given for indication only. The actual capacity at this stage depends on operating conditions.

**PHYSICAL DATA, UNITS FOR HIGH CONDENSING TEMPERATURES**

**Standard-efficiency units (option 150)**

30XW--/30XWH-	852	1002	1052	1154	1252	1352	1452	1552	1652	1702
---------------	-----	------	------	------	------	------	------	------	------	------

**Heating**

<b>Unit + option 150</b> Full load performances*	HW1	Nominal capacity	kW	963	1163	1228	1338	1432	1551	1671	1776	1928	1991
		COP	kW/kW	5,36	5,37	5,28	5,38	5,56	5,32	5,23	5,12	5,34	5,27
	HW2	Nominal heating capacity	kW	939	1085	1146	1290	1329	1445	1558	1649	1873	1936
		COP	kW/kW	4,46	4,46	4,40	4,48	4,63	4,45	4,38	4,34	4,50	4,46
	HW3	Nominal capacity	kW	915	1012	1068	1249	1244	1345	1452	1543	1821	1882
		COP	kW/kW	3,73	3,71	3,66	3,77	3,83	3,68	3,64	3,63	3,81	3,77
Seasonal energy efficiency**	HW1	SCOP <sub>30/35°C</sub>	kWh/kWh	5,66	5,86	5,86	5,78	6,09	5,69	5,79	5,43	5,93	5,92
		η <sub>s heat</sub> <sub>30/35°C</sub>	%	218	226	226	223	236	220	224	209	229	229
	HW3	SCOP <sub>47/55°C</sub>	kWh/kWh	4,47	4,73	4,73	4,61	4,68	4,38	4,45	4,35	4,74	4,76
		η <sub>s heat</sub> <sub>47/55°C</sub>	%	171	181	181	176	179	167	170	166	182	182
	P <sub>rated</sub>		kW	1094	1234	1303	1497	1518	1641	1770	1882	2179	2253

**Cooling**

<b>Unit + option 150</b> Full load performances*	CW1	Nominal cooling capacity	kW	NA	NA	NA	NA	NA	NA	NA	NA	NA	NA
		EER	kW/kW	NA	NA	NA	NA	NA	NA	NA	NA	NA	NA
Seasonal energy efficiency**	<b>SEER<sub>12/7°C</sub> Comfort low temp.</b>		<b>kWh/kWh</b>	NA	NA	NA	NA	NA	NA	NA	NA	NA	NA
	η <sub>s cool</sub> <sub>12/7°C</sub>		%	NA	NA	NA	NA	NA	NA	NA	NA	NA	NA
	SEPR <sub>12/7°C</sub> Process high temp.		kWh/kWh	NA	NA	NA	NA	NA	NA	NA	NA	NA	NA
Integrated Part Load Value	IPLV.SI	kW/kW	6,351	6,572	6,595	6,522	6,873	6,211	6,615	6,366	6,939	7,136	

**Sound levels - unit with option 150**

Sound power level <sup>(1)</sup>	dB(A)	102	102	102	102	105	105	105	105	105	105
Sound pressure level at 1 m <sup>(2)</sup>	dB(A)	84	84	84	84	86	86	86	86	86	86

**Sound levels - unit with option 150 + option 257<sup>(3)</sup>**

Sound power level <sup>(1)</sup>	dB(A)	100	99	99	99	103	103	103	103	103	103
Sound pressure level at 1 m <sup>(2)</sup>	dB(A)	82	80	80	80	84	84	84	84	84	84

**Dimensions - unit with option 150**

Length	mm	2780	4025	4025	4025	4730	4730	4730	4730	4790	4790
Width	mm	1090	1036	1036	1036	1201	1201	1201	1201	1947	1947
Height	mm	1920	1870	1870	1925	2071	2071	2071	2071	1535	1535

**Operating weight<sup>(4)</sup>**

<b>Compressors</b>		Semi-hermetic 06T screw compressors, 50 r/s										
Circuit A	-	1	1	1	1	1	1	1	1	1	1	1
Circuit B	-	1	1	1	1	1	1	1	1	1	1	1

\* In accordance with standard EN14511-3:2022.  
 \*\* In accordance with standard EN14825:2022, average climate  
 HW1 Heating mode conditions: Evaporator entering/leaving water temperature 10°C/7°C, condenser entering/leaving water temperature 30°C/35°C, evaporator and condenser fouling factor 0 m<sup>2</sup>. k/W  
 HW2 Heating mode conditions: Evaporator entering/leaving water temperature 10°C/7°C, condenser entering/leaving water temperature 40°C/45°C, evaporator and condenser fouling factor 0 m<sup>2</sup>. k/W  
 HW3 Heating mode conditions: Evaporator entering/leaving water temperature 10°C/7°C, condenser entering/leaving water temperature 47°C/55°C, evaporator and condenser fouling factor 0 m<sup>2</sup>. k/W  
 CW1 Cooling mode conditions: Evaporator water entering/leaving temperature 12°C/7°C, condenser entering/leaving water temperature 30°C/35°C, evaporator and condenser fouling factor 0 m<sup>2</sup>. K/W  
 η<sub>s heat</sub> <sub>30/35°C</sub> & SCOP<sub>30/35°C</sub> Values calculated in accordance with EN14825:2022  
 η<sub>s heat</sub> <sub>47/55°C</sub> & SCOP<sub>47/55°C</sub> Values calculated in accordance with EN14825:2022  
 η<sub>s cool</sub> <sub>12/7°C</sub> & SEER<sub>12/7°C</sub> **Bold values compliant to Ecodesign regulation: (EU) No 2016/2281 for Comfort application**  
 SEPR<sub>12/7°C</sub> Values calculated in accordance with EN14825:2022  
 IPLV.SI Calculations according to standard performances AHRI 551-591 (SI).  
 (1) In dB ref=10<sup>-12</sup> W, (A) weighting. Declared dualnumber noise emission values in accordance with ISO 4871 (with an associated uncertainty of +/-3dB(A)). Measured in accordance with ISO 9614-1 and certified by Eurovent.  
 (2) In dB ref 20μPa, (A) weighting. Declared dualnumber noise emission values in accordance with ISO 4871 (with an associated uncertainty of +/-3dB(A)). For information, calculated from the sound power level Lw(A).  
 (3) Option 257 = Low noise level  
 (4) Weight shown is guideline only. Please refer to the unit nameplate



Eurovent certified values



AHRI certified values  
30XW-only

## PHYSICAL DATA, UNITS FOR HIGH CONDENSING TEMPERATURES

### Standard-efficiency units (option 150)

30XW--/30XWH-		852	1002	1052	1154	1252	1352	1452	1552	1652	1702
<b>Refrigerant <sup>(4)</sup></b>		R-134a									
Circuit A	kg	158	85	85	105	120	115	110	105	195	195
	teqCO <sub>2</sub>	226	122	122	150	172	164	157	150	279	279
Circuit B	kg	-	85	85	105	120	115	110	105	195	195
	teqCO <sub>2</sub>	-	122	122	150	172	164	157	150	279	279
<b>Oil - unit with option 150</b>											
Circuit A	l	36	32	32	32	36	36	36	36	36	36
Circuit B	l	-	32	32	32	32	36	36	36	36	36
<b>Capacity control</b>		SmartVu™, electronic expansion valves (EXV)									
Minimum capacity <sup>(5)</sup>	%	25	15	15	15	15	10	10	10	10	10
<b>Evaporator</b>		Multi-pipe flooded type									
Water volume	l	98	182	182	205	301	301	301	301	354	354
Water connections (Victaulic)	in	6	6	6	8	8	8	8	8	8	8
Drain and vent connections (NPT)	in	3/8	3/8	3/8	3/8	3/8	3/8	3/8	3/8	3/8	3/8
Max. water-side operating pressure	kPa	1000	1000	1000	1000	1000	1000	1000	1000	1000	1000
<b>Condenser</b>		Multi-pipe flooded type									
Water volume	l	137	193	193	193	340	340	340	340	426	426
Water connections (Victaulic)	in	8	8	8	8	8	8	8	8	8	8
Drain and vent connections (NPT)	in	3/8	3/8	3/8	3/8	3/8	3/8	3/8	3/8	3/8	3/8
Max. water-side operating pressure	kPa	1000	1000	1000	1000	1000	1000	1000	1000	1000	1000

(4) Weight shown is guideline only. Please refer to the unit nameplate

(5) Minimum unit capacity corresponds to a physical state of the unit and is given for indication only. The actual capacity at this stage depends on operating conditions.



# PHYSICAL DATA, UNITS FOR HIGH CONDENSING TEMPERATURES

## Standard-efficiency units (option 150)

30XW-P / 30XWHP	512	562	712	812	862	1012	1162	1314	1464	1612	1762
-----------------	-----	-----	-----	-----	-----	------	------	------	------	------	------

### Heating

Unit + option 150														
Full load performances*	HW1	Nominal capacity	kW	600	670	840	910	975	1188	1375	1514	1698	1890	1983
		COP	kW/kW	5,89	5,90	5,72	5,58	5,72	5,61	5,77	5,55	5,40	5,78	5,73
	HW2	Nominal heating capacity	kW	580	646	815	885	950	1147	1322	1465	1648	1834	1929
		COP	kW/kW	4,85	4,86	4,72	4,61	4,75	4,65	4,80	4,62	4,52	4,80	4,79
	HW3	Nominal capacity	kW	561	625	790	862	925	1110	1275	1419	1598	1783	1874
		COP	kW/kW	4,02	4,04	3,92	3,83	3,97	3,86	4,01	3,88	3,81	4,00	4,00
Seasonal energy efficiency**	HW1	SCOP <sub>30/35°C</sub>	kWh/kWh	6,15	6,22	6,40	6,11	5,99	5,97	6,24	6,18	6,18	6,50	6,21
		ηs heat <sub>30/35°C</sub>	%	238	241	248	236	231	231	242	239	239	252	240
		SCOP <sub>47/55°C</sub>	kWh/kWh	4,78	4,86	4,97	4,76	4,73	4,63	4,88	4,88	4,94	5,07	4,92
	HW3	ηs heat <sub>47/55°C</sub>	%	183	186	191	182	181	177	187	187	189	195	189
		P <sub>rated</sub>	kW	673	749	947	1030	1106	1330	1531	1701	1915	2133	2243

### Cooling

Unit + option 150														
Full load performances*	CW1	Nominal cooling capacity	kW	510	569	715	770	833	1011	1178	1287	1437	1613	1706
		EER	kW/kW	5,14	5,17	5,02	4,88	5,09	4,98	5,23	4,96	4,84	5,15	5,21
Seasonal energy efficiency**		SEER <sub>12/7°C</sub> Comfort low temp.	kWh/kWh	<b>6,53</b>	<b>6,68</b>	<b>6,81</b>	<b>6,56</b>	<b>6,45</b>	<b>6,51</b>	<b>6,95</b>	<b>6,76</b>	<b>6,66</b>	<b>7,13</b>	<b>6,90</b>
		ηs cool <sub>12/7°C</sub>	%	<b>258</b>	<b>264</b>	<b>269</b>	<b>259</b>	<b>255</b>	<b>258</b>	<b>275</b>	<b>267</b>	<b>264</b>	<b>282</b>	<b>273</b>
		SEPR <sub>12/7°C</sub> Process high temp.	kWh/kWh	6,90	6,93	7,23	6,68	6,38	6,71	6,97	6,88	7,03	7,15	6,63
Integrated Part Load Value	IPLV.SI	kW/kW	6,612	6,804	7,029	6,703	6,782	6,505	6,997	6,946	7,131	7,302	7,308	

### Sound levels - unit with option 150

Sound power level <sup>(1)</sup>	dB(A)	99	99	102	102	102	102	102	102	105	105	105	105
Sound pressure level at 1 m <sup>(2)</sup>	dB(A)	82	82	84	84	84	83	83	83	86	86	86	86

### Sound levels - unit with option 150 + option 257<sup>(3)</sup>

Sound power level <sup>(1)</sup>	dB(A)	96	96	100	100	100	99	99	103	103	103	103
Sound pressure level at 1 m <sup>(2)</sup>	dB(A)	78	78	82	82	82	80	80	84	84	84	84

### Dimensions - unit with option 150

Length	mm	3059	3059	3290	3290	3290	4730	4730	4730	4730	4832	4832
Width	mm	936	936	1105	1105	1105	1039	1039	1202	1202	2174	2174
Height	mm	1743	1743	1970	1970	1970	1997	1997	2071	2071	1585	1585

### Operating weight<sup>(4)</sup>

Operating weight <sup>(4)</sup>	kg	2981	3020	4072	4117	4145	6872	6950	7721	8059	11225	11279
<b>Compressors</b>		Semi-hermetic 06T screw compressors, 50 r/s										
Circuit A	-	1	1	1	1	1	1	1	1	1	1	1
Circuit B	-	-	-	-	-	-	1	1	1	1	1	1

\* In accordance with standard EN14511-3:2022.  
 \*\* In accordance with standard EN14825:2022, average climate  
 HW1 Heating mode conditions: Evaporator entering/leaving water temperature 10°C/7°C, condenser entering/leaving water temperature 30°C/35°C, evaporator and condenser fouling factor 0 m<sup>2</sup>. kW  
 HW2 Heating mode conditions: Evaporator entering/leaving water temperature 10°C/7°C, condenser entering/leaving water temperature 40°C/45°C, evaporator and condenser fouling factor 0 m<sup>2</sup>. kW  
 HW3 Heating mode conditions: Evaporator entering/leaving water temperature 10°C/7°C, condenser entering/leaving water temperature 47°C/55°C, evaporator and condenser fouling factor 0 m<sup>2</sup>. kW  
 CW1 Cooling mode conditions: Evaporator water entering/leaving temperature 12°C/7°C, condenser entering/leaving water temperature 30°C/35°C, evaporator and condenser fouling factor 0 m<sup>2</sup>.K/W  
 ηs heat<sub>30/35°C</sub> & SCOP<sub>30/35°C</sub> Values calculated in accordance with EN14825:2022  
 ηs heat<sub>47/55°C</sub> & SCOP<sub>47/55°C</sub> Values calculated in accordance with EN14825:2022  
 ηs cool<sub>12/7°C</sub> & SEER<sub>12/7°C</sub> **Bold values compliant to Ecodesign regulation: (EU) No 2016/2281 for Comfort application**  
 SEPR<sub>12/7°C</sub> Values calculated in accordance with EN14825:2022  
 IPLV.SI Calculations according to standard performances AHRI 551-591 (SI).  
 (1) In dB ref=10<sup>-12</sup> W, (A) weighting. Declared dualnumber noise emission values in accordance with ISO 4871 (with an associated uncertainty of +/-3dB(A)). Measured in accordance with ISO 9614-1 and certified by Eurovent.  
 (2) In dB ref 20μPa, (A) weighting. Declared dualnumber noise emission values in accordance with ISO 4871 (with an associated uncertainty of +/-3dB(A)). For information, calculated from the sound power level Lw(A).  
 (3) Option 257 = Low noise level  
 (4) Weight shown is guideline only. Please refer to the unit nameplate



Eurovent certified values



AHRI certified values 30XW-only

## PHYSICAL DATA, UNITS FOR HIGH CONDENSING TEMPERATURES

### Standard-efficiency units (option 150)

30XW-P / 30XWHP		512	562	712	812	862	1012	1162	1314	1464	1612	1762
<b>Refrigerant (4)</b>		R-134a										
Circuit A	kg	130	130	180	175	177	120	120	130	130	240	250
	teqCO <sub>2</sub>	186	186	257	250	253	172	172	186	186	343	358
Circuit B	kg	-	-	-	-	-	120	120	150	130	240	250
	teqCO <sub>2</sub>	-	-	-	-	-	172	172	215	186	343	358
<b>Oil - unit with option 150</b>												
Circuit A	l	32	32	36	36	36	32	32	36	36	36	36
Circuit B	l	-	-	-	-	-	32	32	32	36	36	36
<b>Capacity control</b>		SmartVu™, electronic expansion valves (EXV)										
Minimum capacity (5)	%	30	30	20	20	20	15	15	15	10	10	10
<b>Evaporator</b>		Multi-pipe flooded type										
Water volume	l	101	101	154	154	154	293	293	321	321	473	473
Water connections (Victaulic)	in	6	6	8	8	8	8	8	8	8	10	10
Drain and vent connections (NPT)	in	3/8	3/8	3/8	3/8	3/8	3/8	3/8	3/8	3/8	3/8	3/8
Max. water-side operating pressure	kPa	1000	1000	1000	1000	1000	1000	1000	1000	1000	1000	1000
<b>Condenser</b>		Multi-pipe flooded type										
Water volume	l	103	103	148	148	148	316	316	340	340	623	623
Water connections (Victaulic)	in	6	6	8	8	8	8	8	10	10	10	10
Drain and vent connections (NPT)	in	3/8	3/8	3/8	3/8	3/8	3/8	3/8	3/8	3/8	3/8	3/8
Max. water-side operating pressure	kPa	1000	1000	1000	1000	1000	1000	1000	1000	1000	1000	1000

(4) Weight shown is guideline only. Please refer to the unit nameplate

(5) Minimum unit capacity corresponds to a physical state of the unit and is given for indication only. The actual capacity at this stage depends on operating conditions.

### Standard-efficiency 30XW/30XWH units (options 6)

30XW--/30XWH (reference)		254	304	354	402	452	552	602	702	802
<b>Operating weight</b>	kg	2041	2063	2102	2609	2609	2647	2678	3492	3516
<b>Refrigerant charge(1)</b>		R-134a								
Circuit A	kg	91	86	84	99	99	99	99	146	135
	teqCO <sub>2</sub>	129730	123552	120463	142085	142085	142085	142085	208494	193050
Circuit B	kg	0	0	0	0	0	0	0	0	0
	teqCO <sub>2</sub>	0	0	0	0	0	0	0	0	0
<b>Evaporator</b>		Single pass, multi-pipe flooded type								
Water volume	l	50	56	61	70	70	70	70	109	109
Water connections (Victaulic)	in	5	5	5	6	6	6	6	6	6
Drain and vent connections (NPT)	in	3/8	3/8	3/8	3/8	3/8	3/8	3/8	3/8	3/8
Max. water-side operating pressure	kPa	1000	1000	1000	1000	1000	1000	1000	1000	1000
<b>30XW--/30XWH (reference)</b>		852	1002	1052	1154	1252	1452	1552	1652	1702
<b>Operating weight</b>	kg	3720	5467	5505	5806	7392	7781	7829	9193	9219
<b>Refrigerant charge(1)</b>		R-134a								
Circuit A	kg	171	92	92	113	130	119	113	211	211
	teqCO <sub>2</sub>	244015	131274	131274	162162	185328	169884	162162	301158	301158
Circuit B	kg	0	92	92	113	130	119	113	211	211
	teqCO <sub>2</sub>	0	131274	131274	162162	185328	169884	162162	301158	301730
<b>Evaporator</b>		Single pass, multi-pipe flooded type								
Water volume	l	98	182	182	205	301	301	301	354	354
Water connections (Victaulic)	in	6	6	6	8	8	8	8	8	8
Drain and vent connections (NPT)	in	3/8	3/8	3/8	3/8	3/8	3/8	3/8	3/8	3/8
Max. water-side operating pressure	kPa	1000	1000	1000	1000	1000	1000	1000	1000	1000

(1) Weights are guidelines only. The refrigerant charge is given on the unit nameplate.

## ELECTRICAL DATA, UNITS FOR HIGH CONDENSING TEMPERATURES

### Standard-efficiency units (option 150)

30XWH-/30XWH-		254	304	354	402	452	552	602	652	702	802
<b>Power circuit</b>											
Nominal power supply	V-ph-Hz	400-3-50									
Voltage range	V	360-440									
<b>Control circuit</b>											
24 V via the built-in transformer											
<b>Nominal start-up current <sup>(1)</sup></b>											
Circuit A	A	303	388	388	587	587	587	587	772	772	772
Circuit B	A	-	-	-	-	-	-	-	-	-	-
Option 81	A	-	-	-	-	-	-	-	-	-	-
<b>Maximum start-up current <sup>(2)</sup></b>											
Circuit A	A	303	388	388	587	587	587	587	772	772	772
Circuit B	A	-	-	-	-	-	-	-	-	-	-
Option 81	A	-	-	-	-	-	-	-	-	-	-
<b>Cosine phi</b>											
Nominal <sup>(3)</sup>		0,79	0,78	0,79	0,83	0,85	0,85	0,85	0,84	0,86	0,87
Maximum <sup>(4)</sup>		0,88	0,87	0,88	0,90	0,90	0,91	0,91	0,90	0,90	0,90
Total harmonic distortion <sup>(4)</sup>	%	0	0	0	0	0	0	0	0	0	0
<b>Maximum power input†</b>											
Circuit A	kW	97	111	122	156	173	191	191	249	268	286
Circuit B	kW	-	-	-	-	-	-	-	-	-	-
Option 81	kW	-	-	-	-	-	-	-	-	-	-
<b>Nominal current drawn <sup>(3)</sup></b>											
Circuit A	A	95	109	125	150	162	171	171	193	214	232
Circuit B	A	-	-	-	-	-	-	-	-	-	-
Option 81	A	-	-	-	-	-	-	-	-	-	-
<b>Maximum current drawn (Un)†</b>											
Circuit A	A	160	185	200	250	275	300	300	400	430	460
Circuit B	A	-	-	-	-	-	-	-	-	-	-
Option 81	A	-	-	-	-	-	-	-	-	-	-
<b>Maximum current drawn (Un -10%) <sup>(4)</sup></b>											
Circuit A	A	176	206	224	270	300	330	330	419	455	476
Circuit B	A	-	-	-	-	-	-	-	-	-	-
Option 81	A	-	-	-	-	-	-	-	-	-	-

(1) Instantaneous start-up current (maximum operating current of the smallest compressor(s) + locked rotor current or reduced start-up current of the largest compressor). Values based on standard Eurovent unit operating conditions: evaporator entering/leaving water temp. = 12°C/7°C, condenser entering/leaving water temp. = 30°C/35°C.

(2) Instantaneous start-up current (maximum operating current of the smallest compressor(s) + locked rotor current or reduced start-up current of the largest compressor). Values obtained at operation with maximum unit power input.

(3) Values based on standard Eurovent unit operating conditions: evaporator entering/leaving water temp. = 12°C/7°C, condenser entering/leaving water temp. = 30°C/35°C.

(4) Values obtained at operation with maximum unit power input.

† Values obtained at operation with maximum unit power input. Values given on the unit name plate.

## ELECTRICAL DATA, UNITS FOR HIGH CONDENSING TEMPERATURES

### Standard-efficiency units (option 150)

30XW--/30XWH-		852	1002	1052	1154	1252	1352	1452	1552	1652	1702
<b>Power circuit</b>											
Nominal power supply	V-ph-Hz	400-3-50									
Voltage range	V	360-440									
<b>Control circuit</b>											
24 V via the built-in transformer											
<b>Nominal start-up current <sup>(1)</sup></b>											
Circuit A	A	772	587	587	587	772	772	772	772	772	772
Circuit B	A	-	587	587	587	587	772	772	772	772	772
Option 81	A	-	757	757	757	943	965	986	1004	1004	1004
<b>Maximum start-up current <sup>(2)</sup></b>											
Circuit A	A	772	587	587	587	772	772	772	772	772	772
Circuit B	A	-	587	587	587	587	772	772	772	772	772
Option 81	A	-	887	887	887	1072	1172	1202	1232	1004	1232
<b>Cosine phi</b>											
Nominal <sup>(3)</sup>		0,87	0,85	0,85	0,85	0,86	0,85	0,86	0,87	0,86	0,87
Maximum <sup>(4)</sup>		0,90	0,90	0,91	0,91	0,91	0,91	0,91	0,91	0,91	0,91
Total harmonic distortion <sup>(4)</sup>	%	0	0	0	0	0	0	0	0	0	0
<b>Maximum power input†</b>											
Circuit A	kW	286	191	191	191	252	252	271	290	290	290
Circuit B	kW	-	173	191	191	191	252	271	290	271	290
Option 81	kW	-	364	382	382	443	504	542	580	562	580
<b>Nominal current drawn <sup>(3)</sup></b>											
Circuit A	A	232	171	171	171	210	210	230	250	250	250
Circuit B	A	-	162	171	171	171	210	230	250	230	250
Option 81	A	-	333	342	342	381	420	460	500	480	500
<b>Maximum current drawn (Un)†</b>											
Circuit A	A	460	300	300	300	400	400	430	460	460	460
Circuit B	A	-	275	300	300	300	400	430	460	430	460
Option 81	A	-	575	600	600	700	800	860	920	890	920
<b>Maximum current drawn (Un -10%) <sup>(4)</sup></b>											
Circuit A	A	476	330	330	330	419	419	455	476	476	476
Circuit B	A	-	300	330	330	330	419	455	476	455	476
Option 81	A	-	630	660	660	749	838	910	952	931	952

(1) Instantaneous start-up current (maximum operating current of the smallest compressor(s) + locked rotor current or reduced start-up current of the largest compressor). Values based on standard Eurovent unit operating conditions: evaporator entering/leaving water temp. = 12°C/7°C, condenser entering/leaving water temp. = 30°C/35°C.

(2) Instantaneous start-up current (maximum operating current of the smallest compressor(s) + locked rotor current or reduced start-up current of the largest compressor). Values obtained at operation with maximum unit power input.

(3) Values based on standard Eurovent unit operating conditions: evaporator entering/leaving water temp. = 12°C/7°C, condenser entering/leaving water temp. = 30°C/35°C.

(4) Values obtained at operation with maximum unit power input.

† Values obtained at operation with maximum unit power input. Values given on the unit name plate.

## ELECTRICAL DATA, UNITS FOR HIGH CONDENSING TEMPERATURES

### High-efficiency units (option 150)

30XW-P/30XWHP		512	562	712	812	862	1012	1162	1314	1464	1612	1762
<b>Power circuit</b>												
Nominal power supply	V-ph-Hz	400-3-50										
Voltage range	V	360-440										
<b>Control circuit</b>												
24 V via the built-in transformer												
<b>Nominal start-up current <sup>(1)</sup></b>												
Circuit A	A	587	587	772	772	772	587	587	772	772	772	772
Circuit B	A	-	-	-	-	-	587	587	587	772	772	772
Option 81	A	-	-	-	-	-	749	757	943	965	986	1004
<b>Maximum start-up current <sup>(2)</sup></b>												
Circuit A	A	587	587	772	772	772	587	587	772	772	772	772
Circuit B	A	-	-	-	-	-	587	587	587	772	772	772
Option 81	A	-	-	-	-	-	862	887	1072	1172	1202	1232
<b>Cosine phi</b>												
Nominal <sup>(3)</sup>		0,88	0,88	0,84	0,86	0,87	0,87	0,88	0,86	0,85	0,86	0,87
Maximum <sup>(4)</sup>		0,91	0,92	0,90	0,90	0,90	0,91	0,92	0,91	0,91	0,91	0,91
Total harmonic distortion <sup>(4)</sup>	%	0	0	0	0	0	0	0	0	0	0	0
<b>Maximum power input†</b>												
Circuit A	kW	173	191	252	271	290	173	191	252	252	271	290
Circuit B	kW	-	-	-	-	-	173	191	191	252	271	290
Option 81	kW	-	-	-	-	-	346	382	443	504	542	580
<b>Nominal current drawn <sup>(3)</sup></b>												
Circuit A	A	162	171	210	230	250	162	171	210	210	230	250
Circuit B	A	-	-	-	-	-	162	171	171	210	230	250
Option 81	A	-	-	-	-	-	324	342	381	420	460	500
<b>Maximum current drawn (Un)†</b>												
Circuit A	A	275	300	400	430	460	275	300	400	400	430	460
Circuit B	A	-	-	-	-	-	275	300	300	400	430	460
Option 81	A	-	-	-	-	-	550	600	700	800	860	920
<b>Maximum current drawn (Un -10%) <sup>(4)</sup></b>												
Circuit A	A	300	330	419	455	476	300	330	419	419	455	476
Circuit B	A	-	-	-	-	-	300	330	330	419	455	476
Option 81	A	-	-	-	-	-	600	660	749	838	910	952

(1) Instantaneous start-up current (maximum operating current of the smallest compressor(s) + locked rotor current or reduced start-up current of the largest compressor). Values based on standard Eurovent unit operating conditions: evaporator entering/leaving water temp. = 12°C/7°C, condenser entering/leaving water temp. = 30°C/35°C.

(2) Instantaneous start-up current (maximum operating current of the smallest compressor(s) + locked rotor current or reduced start-up current of the largest compressor). Values obtained at operation with maximum unit power input.

(3) Values based on standard Eurovent unit operating conditions: evaporator entering/leaving water temp. = 12°C/7°C, condenser entering/leaving water temp. = 30°C/35°C.

(4) Values obtained at operation with maximum unit power input.

† Values obtained at operation with maximum unit power input. Values given on the unit name plate.

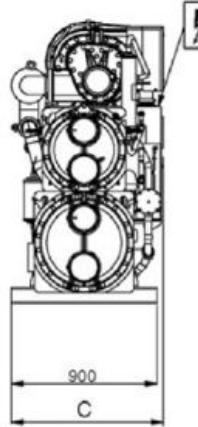
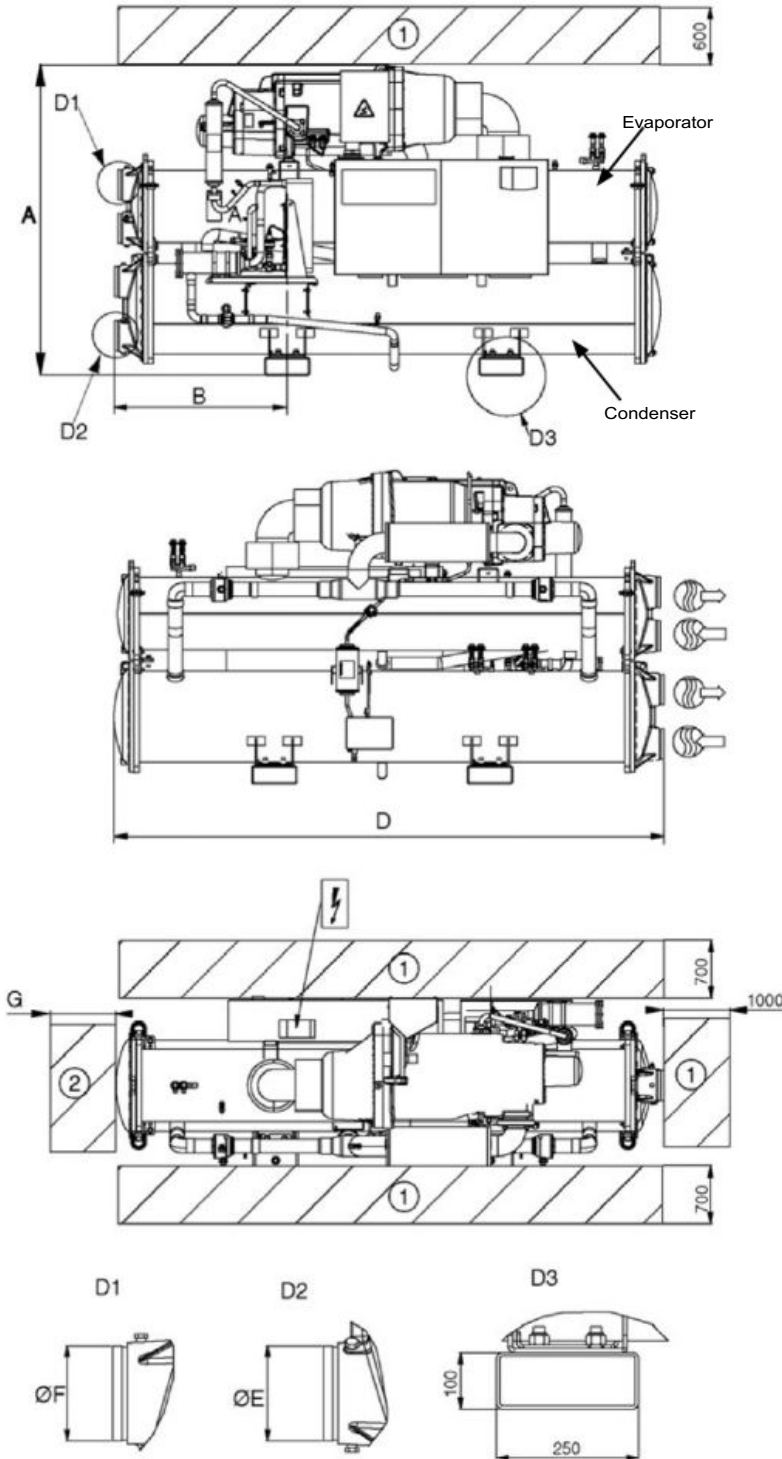

## DIMENSIONS/CLEARANCES

**30XW--/30XWH- 254-852**
**30XW-P/30XWHP 512-862**

	Dimensions in mm						
	A	B	C	D	E	F	G
<b>Standard-efficiency units 30XW--/30XWH-</b>							
254	1567	800	928	2724	141,3	141,3	2600
304	1567	800	928	2724	141,3	141,3	2600
354	1567	800	928	2724	141,3	141,3	2600
402	1693	810	936	2742	141,3	141,3	2600
452	1693	810	936	2742	141,3	141,3	2600
552	1693	810	936	2742	141,3	141,3	2600
602	1693	810	936	2742	141,3	141,3	2600
652	1848	968	1044	3059	168,3	168,3	2800
702	1848	968	1044	3059	168,3	168,3	2800
802	1848	968	1044	3059	168,3	168,3	2800
852	1898	828	1044	2780	219,1	168,3	2600
<b>High-efficiency units 30XW-P/30XWHP</b>							
512	1743	968	936	3059	168,3	168,3	2800
562	1743	968	936	3059	168,3	168,3	2800
712	1950	1083	1065	3290	219,1	219,1	3100
812	1950	1083	1070	3290	219,1	219,1	3100
862	1950	1083	1070	3290	219,1	219,1	3100
<b>Standard-efficiency units 30XW--/30XWH- (option 150)</b>							
254	1567	800	928	2724	141,3	141,3	2600
304	1567	800	928	2724	141,3	141,3	2600
354	1567	800	928	2724	141,3	141,3	2600
402	1693	810	936	2742	141,3	141,3	2600
452	1693	810	936	2742	141,3	141,3	2600
552	1693	810	936	2742	141,3	141,3	2600
602	1693	810	936	2742	141,3	141,3	2600
652	1868	968	1090	3059	168,3	168,3	2800
702	1868	968	1090	3059	168,3	168,3	2800
802	1868	968	1090	3059	168,3	168,3	2800
852	1920	828	1090	2780	168,3	219,1	2600
<b>High-efficiency units 30XW-P/30XWHP (option 150)</b>							
512	1743	968	936	3059	168,3	168,3	2800
562	1743	968	936	3059	168,3	168,3	2800
712	1970	1083	1105	3290	219,1	219,1	3100
812	1970	1083	1105	3290	219,1	219,1	3100
862	1970	1083	1105	3290	219,1	219,1	3100

**Legend**

All dimensions are given in mm.

- ① Required clearance for maintenance
- ② Recommended clearance for tube removal
- Water inlet
- Water outlet
- Air outlet – do not obstruct
- Power supply connection

- Option 6 has same dimensions as option 150.
- Option 20 (IP44) has same dimensions as option 150 on units 652, 712, 802, 852, 862. Option 20 has same dimensions as standard on the other units.

**NOTE:** Drawings are not contractually binding. Before designing an installation, consult the certified dimensional drawings, available on request.

## DIMENSIONS/CLEARANCES

30XW--/30XWH- 1002-1552  
 30XW-P/30XWHP 1012-1464

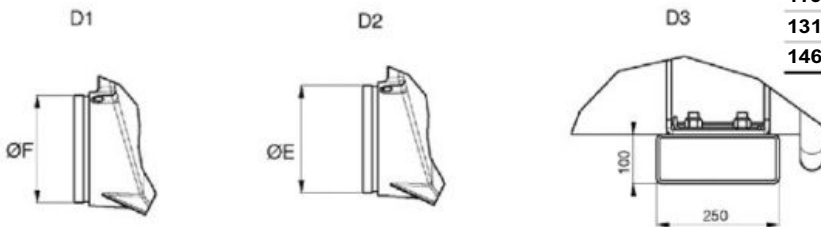
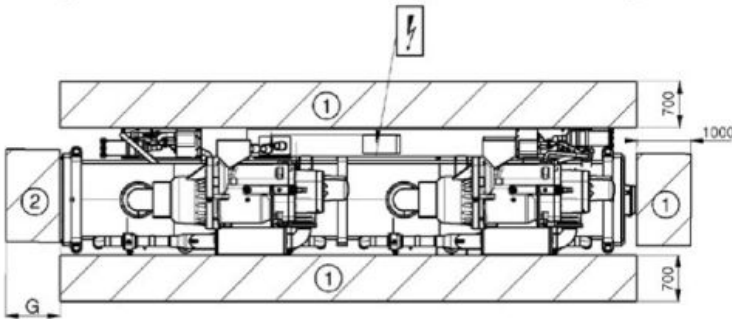
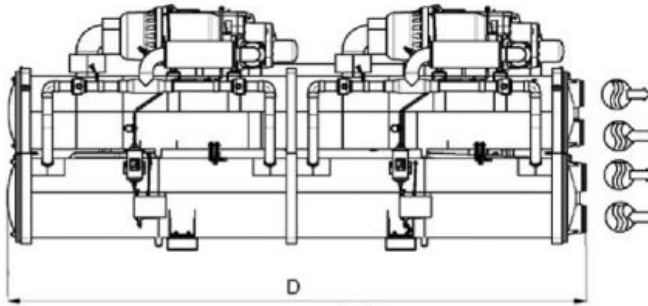
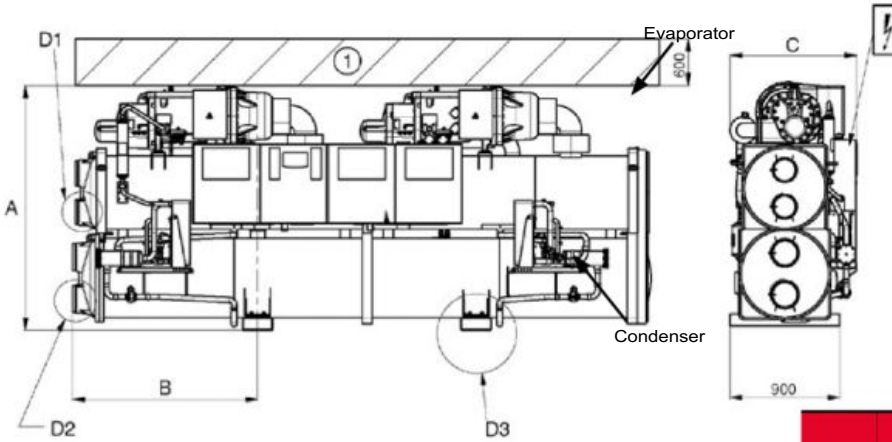

	Dimensions in mm						
	A	B	C	D	E	F	G
<b>Standard-efficiency units 30XW--/30XWH-</b>							
1002	1870	950	1036	4025	219,1	168,3	3800
1052	1870	950	1036	4025	219,1	168,3	3800
1152	1925	950	1036	4025	219,1	219,1	3800
1252	2051	1512	1162	4730	219,1	219,1	4500
1352	2051	1512	1162	4730	219,1	219,1	4500
1452	2051	1512	1162	4730	219,1	219,1	4500
1552	2051	1512	1162	4730	219,1	219,1	4500
<b>High-efficiency units 30XW-P/30XWHP</b>							
1012	1997	1512	1039	4730	219,1	219,1	4500
1162	1997	1512	1039	4730	219,1	219,1	4500
1314	2051	1512	1162	4730	219,1	219,1	4500
1464	2051	1512	1162	4730	219,1	219,1	4500
<b>Standard-efficiency units 30XW--/30XWH- (option 150)</b>							
1002	1870	950	1036	4025	219,1	168,3	3800
1052	1870	950	1036	4025	219,1	168,3	3800
1154	2925	950	1036	4025	219,1	219,1	3800
1252	2071	1512	1202	4730	219,1	219,1	4500
1352	2071	1512	1202	4730	219,1	219,1	4500
1452	2071	1512	1202	4730	219,1	219,1	4500
1552	2071	1512	1202	4730	219,1	219,1	4500
<b>High-efficiency units 30XW-P/30XWHP (option 150)</b>							
1012	1997	1512	1039	4730	219,1	219,1	4500
1162	1997	1512	1039	4730	219,1	219,1	4500
1314	2071	1512	1202	4730	219,1	219,1	4500
1464	2071	1512	1202	4730	219,1	219,1	4500

**Legend**

All dimensions are given in mm.

- ① Required clearance for maintenance
- ② Recommended clearance for tube removal
- Water inlet
- Water outlet
- Air outlet – do not obstruct
- Power supply connection

- Option 6 has same dimensions as option 150.  
 - Option 20 (IP44) has same dimensions as option 150 on units 652, 712, 802, 852, 862. Option 20 has same dimensions as standard on the other units.

**NOTE:** Drawings are not contractually binding. Before designing an installation, consult the certified dimensional drawings, available on request.

## DIMENSIONS/CLEARANCES

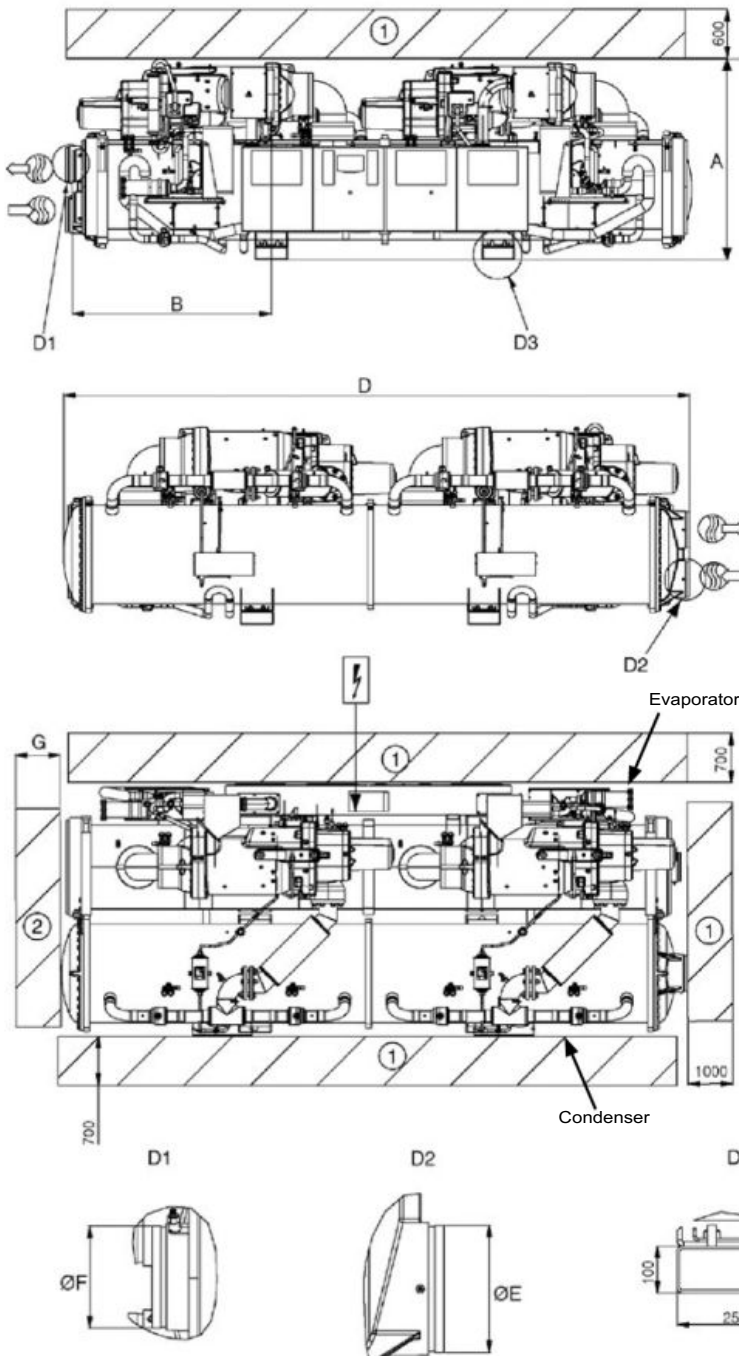
**30XW--/30XWH- 1652-1702**
**30XW-P/30XWHP 1612-1762**

	Dimensions in mm						
	A	B	C	D	E	F	G
<b>Standard-efficiency units 30XW--/30XWH-</b>							
<b>1652</b>	1515	1568	1902	4790	219,1	219,1	4500
<b>1702</b>	1515	1568	1902	4790	219,1	219,1	4500
<b>High-efficiency units 30XW-P/30XWHP</b>							
<b>1612</b>	1562	1591	2129	4832	273,1	273,1	4600
<b>1762</b>	1562	1591	2129	4832	273,1	273,1	4600
<b>Standard-efficiency units 30XW--/30XWH- (option 150)</b>							
<b>1652</b>	1535	1568	1947	4790	219,1	219,1	4500
<b>1702</b>	1535	1568	1947	4790	219,1	219,1	4500
<b>High-efficiency units 30XW-P/30XWHP (option 150)</b>							
<b>1612</b>	1585	1591	2174	4832	273,1	273,1	4600
<b>1762</b>	1585	1591	2174	4832	273,1	273,1	4600

**Legend**

All dimensions are given in mm.

- ① Required clearance for maintenance
- ② Recommended clearance for tube removal
- Water inlet
- Water outlet
- Air outlet – do not obstruct
- Power supply connection

- Option 6 has same dimensions as option 150.
- Option 20 (IP44) has same dimensions as option 150 on units 652, 712, 802, 852, 862. Option 20 has same dimensions as standard on the other units.

**NOTE:** Drawings are not contractually binding. Before designing an installation, consult the certified dimensional drawings, available on request.



**NEW**

## HIGH TEMPERATURE SERIES AIR SOURCE HEAT PUMP

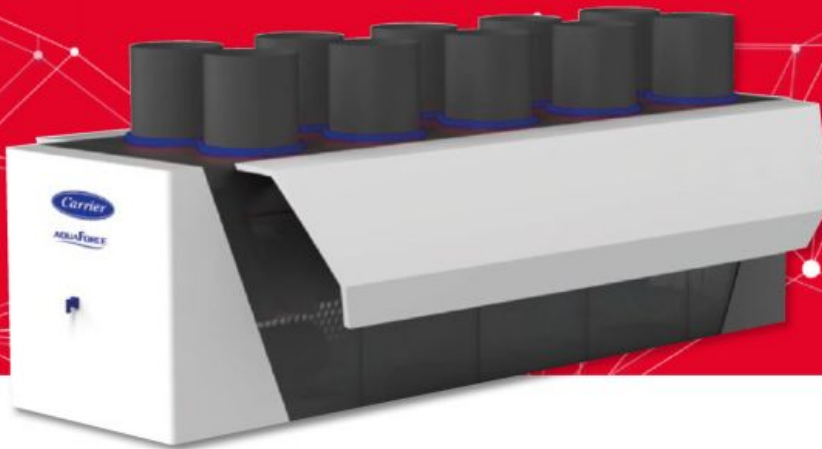

# 61CA

Nominal heating capacity 410 kW

### APPLICATION RANGES

- Heating and cooling
- Large buildings, local and district heating networks
- Outside air temperature from  $-20^{\circ}\text{C}$  to  $+35^{\circ}\text{C}$
- Heat source: air

### DESIGN

- Ultra low GWP R1234yf refrigerant
- Compact design
- Speed controlled fans
- Robust shell and tube heat exchanger as condenser

### OUTPUT RANGE

- Heating output of 410 kW at A2/W82

## AQUAFORCE.





## TECHNICAL INSIGHT

### Compressor

The CARRIER industrial heat pump is equipped with a semi-hermetic, two-stage compact screw compressor specially designed for the given, extended operating conditions. With a newly developed, asymmetrical high-performance profile, these twin-shaft rotary displacement machines achieve the highest efficiency levels and maximum service life in continuous operation. They have no oscillating components and thus run with low vibration and virtually no wear. The roller bearings are dimensioned for an extremely long service life. The special design allows extended application limits to the lowest external air temperatures and high heating flow temperatures.

Maximum operational reliability is ensured by forced lubrication without an oil pump, as well as an external oil separator on the pressure side and an oil heater. The necessary lubricant flow is automatically ensured by the pressure difference between the high-pressure and low-pressure sides of the refrigerant circuit. An oil heater ensures the lubricity of the oil even after longer downtimes.

The compressor casing includes a three phase asynchronous motor. The rotor of the motor is arranged on the shaft of the main screw rotor. Cooling is by cold refrigerant vapor. The screw compressor is equipped as standard with star-delta switching to reduce the starting current.

### Capacity control

The capacity is controlled by means of a control spool in the compressor at constant motor speed. A hydraulically operated control slide varies the refrigerant charge of the compressor screws according to the power requirement. In contrast to electronic speed control, no additional energy losses are caused by frequency converters. According to the specified temperature setpoint, the heat pump control calculates the required power stage for efficient and safe operation. The power control takes the form of a stepped power control (50%, 75%, 100%).

### Condenser

The condenser is designed as an amply dimensioned shell-and-tube heat exchanger using the counterflow principle. Shell-and-tube heat exchangers ensure safety and robust operation even under difficult conditions. The design of the heat exchangers has been optimized to ensure the highest possible transfer capacity - with the lowest possible pressure loss and smallest possible space requirement. The heat exchangers are insensitive to fouling and pressure shock resistant due to their cylindrical shape.

The condenser is equipped with Victaulic quick connectors.

### Evaporator

The evaporator unit consists of sets of coils arranged at an angle to optimize defrosting. Furthermore, it consists of speed-controlled fans with a large diameter to minimize power consumption and noise emission. Defrost control is demand-driven via micro-compressor to minimize any defrost losses.

### Frost protection

Electric frost protection heating with activation of circulation pump. Minimum temperature for start-up phase to be ensured on the system side.

### Economizer operation

For economizer operation, an additional circuit is used to increase efficiency. With this design, a partial flow steam injection is used to increase both the heating or cooling capacity and the coefficient of performance. Improved performance data is achieved at high condensing temperatures.

The screw compressors used in CARRIER heat pumps are already designed for economizer operation in the standard version.

### Oil cooling system

An oil cooling system consisting of a gear pump and an oil/refrigerant heat exchanger is provided in order to reach the operating limits and for long-term stability of the rotating elements.

### Refrigeration circuit/refrigerant

The refrigerant circuit is filled with a non-toxic fluid (R1234yf) that is only slightly flammable (A2L). The refrigerant used is CFC-free and has a zero-ozone depletion potential and a GWP of 4, making it sustainable. The refrigerant charge is optimized for the highest possible coefficient of performance (COP). The refrigerant circuit is leak-tested using helium or forming gas. The standard unit is equipped with a refrigerant leak detector including a visual and acoustic alarm.

### Electronic expansion valves

Control of the optimum superheat of the refrigerant at each operating point is achieved by a total of 2 independently controlled electronic expansion valve systems in the main refrigeration circuit and in the economizer circuit. To ensure the highest possible efficiency in heating, defrosting and cooling operation. This further optimizes the coefficient of performance (COP) of the heat pump at each operating point.

### Safety equipment

To maximize the service life of the system, special attention is paid to the operational safety of the heat pump and to the protection of the compressor.

### Compressor protection device

CARRIER industrial heat pumps include a protective device for the screw compressor as standard equipment. The protection device is installed in the compressor terminal box and is hard-wired.

It monitors:

- Motor and oil temperatures
- Direction of rotation
- Phase failure

## TECHNICAL INSIGHT

### Additional safety equipment

- Motor protection relay for the compressor
- Overpressure safety valve in the refrigerant circuit
- High and low pressure sensors in the refrigerant circuit for permanent monitoring of the operating limits
- Oil level monitor
- Double high and low pressure pressostat
- Hot gas sensor / monitoring of compressor discharge temperature
- Differential pressure switch on the heat transfer medium side of the evaporator during cooling operation

### Electrical control cabinet

The electrical cabinet of the heat pump is mounted on the frame of the heat pump and contains the power and control section. The customer receives a completely wired and ready-to-operate electrical installation according to the international standard. Design in protection class IP54. The heat pump requires a connection of 3x400V, without neutral conductor.

The power unit includes:

- Switching devices for the compressor: Contactors for star/delta start, optional soft start device with additional phase monitoring
- Contactors for fan and sink circulation pump, overcurrent protection devices, motor protection devices, lockable main switch, transformer for 24 V control circuit, control of solenoid valves and expansion valves, designated terminal strips with inputs and outputs for connection to the BMS (outputs potential-free)

## PHYSICAL DATA

### Air to Water - High Temperature Heat Pump

Unit			61CA-Y380
<b>Performance data<sup>(1)</sup></b>			
Heating Capacity		kW	412,0
Cooling Capacity		kW	204,0
Power Consumption	A2/ W82	kW	216,0
Coefficient of Performance		-	1,9
Drawn Current		A	354,0
Heating Capacity		kW	256
Cooling Capacity		kW	159
Power Consumption	A-17/ W45	kW	108,0
Coefficient of Performance		-	2,4
Drawn Current		A	169
<b>Technical data</b>			
Dimensions (LxWxH) <sup>(2)</sup>		mm	8100 x 2420 x 2753
Weight <sup>(2)</sup>		kg	10700
Refrigerant		-	R1234yf (GWP=4 following AR4, ODP=0)
Refrigerant charge <sup>(2)</sup>		kg	225
		teqCO <sub>2</sub>	0,9
Oil charge		l	61
Voltage/ Frequency		V/Hz	400/50
Rotor starting current Y/Δ		A	875/2625
Max. Operating current		A	450
<b>Compressor</b>			
Quantity		-	1
Type		-	Fixed-speed screw compressor
<b>Evaporator</b>			
Type			Fin / Tube
Material			Copper / Aluminium
Temperature difference <sup>(3)</sup>		K	6
Air flow <sup>(3)</sup>		m <sup>3</sup> /h	150000,0
Fluid type		-	Air
Operating range - Air temperature <sup>(3)</sup>		°C	-20/+35
<b>Condenser</b>			
Type		-	Tube Bundle
Temperature difference <sup>(3)</sup>		K	5
Water flow <sup>(3)</sup>		m <sup>3</sup> /h	72,8
Internal pressure drop <sup>(3)</sup>		mbar	125,0
Fluid type		-	Water
Operating range - Outlet temperature <sup>(3)</sup>		°C	+32/+82
Min. operating pressure <sup>(3)</sup>		bar	1,0
Max. operating pressure <sup>(3)</sup>		bar	10,0

(1) Technical data with tolerance ±10%

(2) Reference values

(3) Data at A2/W82

## OPERATING MAP

### Operating limits

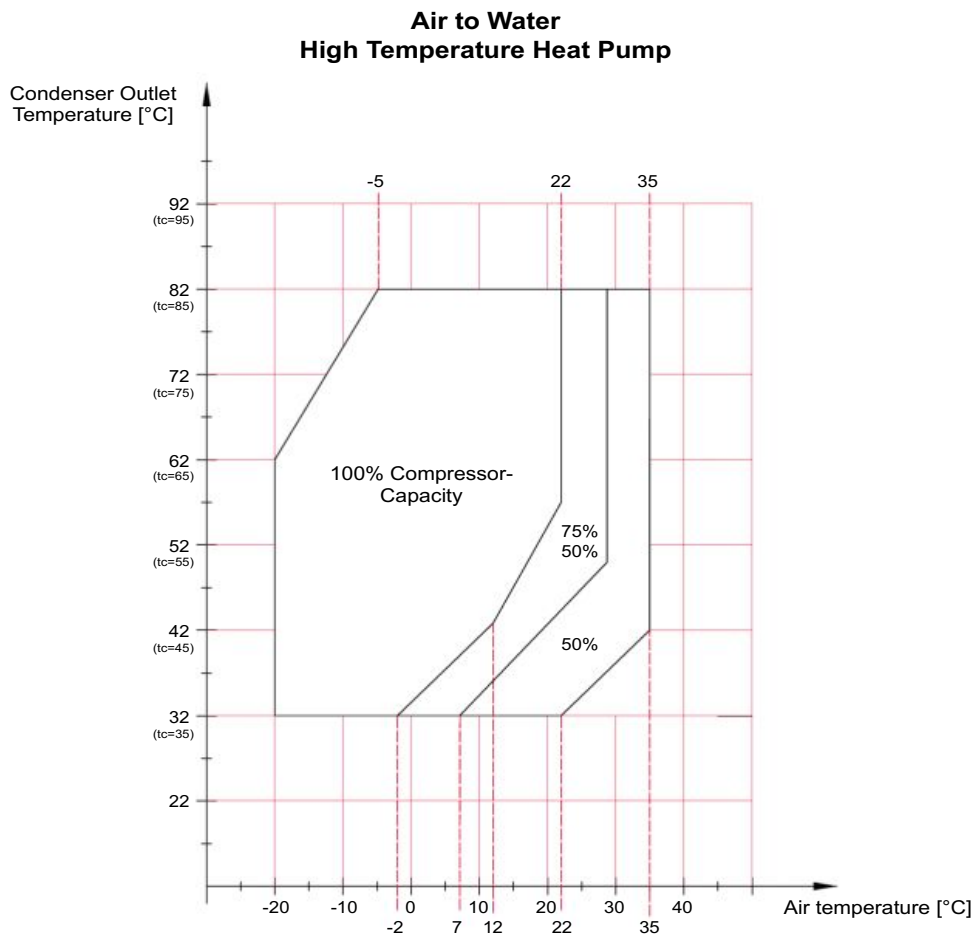

The limits of use defined in the operating map above represents the switch-off values of the heat pump. We recommend a maximum hot water set-point 2°C below the switch-off value for optimized heat pump operation.

## OPTIONS

Options	N°	Description	Advantages	Aquaforce 61CA
Modbus interface (RS 485)	149B	Unit control compatible with the bus interface RS485 Modbus RTU. Other bus interfaces on request	The heat pump control unit with communication capability is easily integrated into the building management system	380
Remote access	275	The touchscreen has two 10/100 Mbit Ethernet ports (RJ45) with an integral switch. Using an Ethernet patch cable, the touchscreen can be connected to the customer company network. The operator/customer must provide a secure VPN tunnel to the customer network.	Allow remote control & Check of the unit and its operating parameters from anywhere in the world and to change/ optimise any settings.	380
Electric energy meter	294	Display of energy consumption of the unit, instantaneous (U, V, I) and cumulated (kWh) of the unit	Permits the acquisition & monitoring of energy used.	380

### DIMENSIONAL DRAWINGS

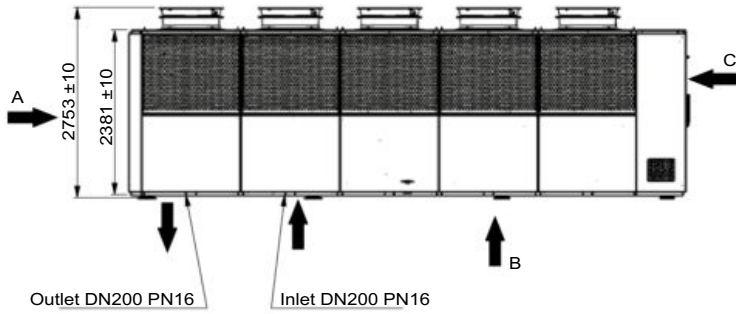
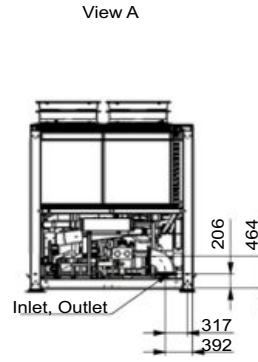
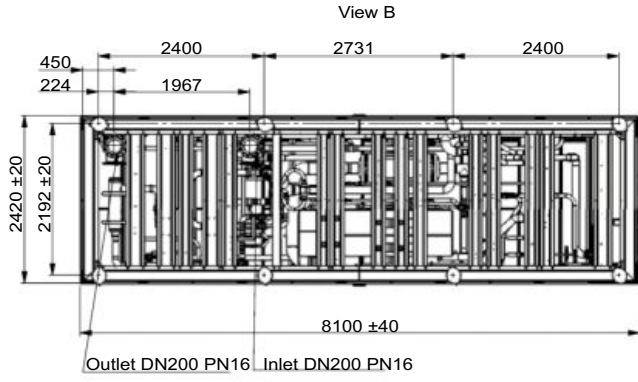



**COMPLETE CARRIER RANGES OF HIGH TEMPERATURE HEAT PUMP FOR COMMERCIAL APPLICATIONS UP TO 82°C**

**AquaSnap 61CG**



**High temperature water source heat pumps**  
30 to 130 kW  
Hot water up to 82°C

**AquaSnap 61WG**



**High temperature water source heat pumps**  
20 to 190 kW  
Hot water up to 65°C

**AquaSnap 61AF**



**High temperature air source heat pumps**  
22 to 105 kW  
Hot water up to 65°C

**COMPLETE CARRIER RANGES OF HIGH TEMPERATURE INDUSTRIAL HEAT PUMP FOR DISTRICT HEATING AND PROCESS APPLICATIONS UP TO 120°C**

**AQUAFORCE 61CA**

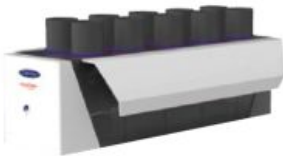

**High temperature air source heat pumps**  
410 kW  
Hot water up to 82°C

**AQUAFORCE 61XWHZE**



**High temperature water source heat pumps**  
300 to 1570 kW  
Hot water up to 85°C

**AQUAFORCE 61CW-Z**



**Very high temperature water source heat pumps**  
410 kW to 735 kW  
Hot water up to 92°C

**AQUAFORCE 61CWD**



**Ultra high temperature water source heat pumps**  
110 kW to 540 kW  
Hot water up to 120°C



**NEW**

## ULTRA HIGH TEMPERATURE SERIES WATER SOURCE HEAT PUMP



# 61CWD

Nominal heating capacity 110 - 540 kW

### APPLICATION RANGES

- Industrial process heating
- District heating networks
- Heat source: water or brine from process heat or heat recovery

### DESIGN

- Ultra-high temperature up to 120°C
- Ultra low GWP R1233zd refrigerant - A1 safety class for indoor installation
- Screw compressors specially designed for high temperatures for heavy-duty continuous use
- Cooling system with internal circuit
- Robust shell and tube heat exchangers
- High efficiency even with small delta T

## AQUAFORCE.



## TECHNICAL INSIGHT

### Compressor

CARRIER high temperature industrial heat pumps are fitted with a semi-hermetic screw compressor specially designed for use in heat pumps with high system temperatures. With a newly developed, asymmetrical high-performance profile, these twin shaft rotation displacement machines achieve the highest levels of efficiency and maximum service life in continuous use.

With no oscillating components, they operate with very low vibrations and virtually no wear. The roller bearings are specially designed for high temperatures and sized to ensure an extremely long service life.

A high degree of operational reliability is guaranteed by means of forced lubrication, and through an integral three-stage oil separator and sump heater on the pressure side. The oil heater ensures the lubricating properties of the oil even after long downtimes. A separate cooling circuit with its own oil pumps and water-cooled oil cooler ensures the required oil temperature and/or correct bearing lubrication at high operating temperatures.

The compressor casing includes a three phase asynchronous motor. The motor armature is mounted on the shaft of the main screw rotor. It is cooled with cold refrigerant vapor. The motor winding is designed especially for the specified temperature conditions. The screw compressors are fitted with part winding (PW) motors (on capacities 110 kW & 130 kW) or a star-delta circuit (on capacities from 160kW to 540 kW) to reduce the starting current.

### Heat exchanger

Evaporators and condensers are used as generously sized shell and tube heat exchangers based on the counterflow principle. Shell and tube heat exchangers ensure reliability and robust operation even under difficult conditions. The design of the heat exchangers has been optimized to ensure the maximum possible transfer capacity along with the smallest possible pressure loss and minimum space requirement. The heat exchangers are not sensitive to fouling and, due to their cylindrical shape, are resistant to pressure shock. The heat exchangers are fitted with flange connections.

### Refrigerant circuit/refrigerant

The refrigerant circuit is filled with a non-combustible and non-toxic safety refrigerant. The refrigerant used is CFC-free and is therefore fully futureproof. The refrigerant charge is optimized for the highest possible coefficient of performance (COP). The refrigerant circuit undergoes a pressure and leakage test using helium or forming gas.

### Safety equipment

To maximize the service life of the system, particular attention has been paid to the operational reliability of the heat pump and to protecting the compressor.

#### Compressor protection device

CARRIER industrial heat pumps are equipped with a protection device for the screw compressor as standard. The protection device is built into the compressor connection box and is fully wired. It monitors:

- Motor and oil temperatures
- Rotational direction
- Phase failure

#### Additional safety equipment

- Motor protection switch for the compressor
- Overpressure safety valve in the refrigerant circuit
- High and low pressure sensors in the refrigerant circuit for electronic monitoring of the limits of use
- Oil level monitor
- Double high pressure controller
- Hot gas sensor/monitoring of compressor outlet temperature
- Flow monitor on the evaporator and condenser
- Flow switch in oil cooling circuit

### Electrical cabinet

The control cabinet of the heat pump is mounted on the long side of the heat pump and contains the power and control unit. The customer receives fully wired electrical equipment that is ready for operation according to the international standard.

Designed with IP 54 protection rating. The heat pump requires a 3x400 V (without neutral conductor) and 1x230 V connections.

The power unit includes:

- Switching elements for the compressor: contactors for part winding or star/delta start
- Contactors for source and sink circulation pumps, depending on requirements of installation overcurrent protection devices, motor protection devices, lockable main switch, transformer for 24 V control circuit, control of solenoid valves and expansion valves, designated terminal strips with inputs and outputs for connection to the BMS (outputs potential-free).

## TECHNICAL INSIGHT

### Control unit

The hardware of the control unit includes a programmable logic controller (PLC) and a Human Machine Interface (HMI). The software for the control unit was developed especially for 61CWD and processes the necessary number of inputs and outputs for controlling the refrigerant circuit.

The control also performs all non-mechanical safety functions of the refrigerant circuit, e.g.: frost protection alarm or field rotation monitoring on the compressor motor.

The HMI has a 10" touchscreen for entering control commands, target values and parameters. For visualization of system statuses and actual values, these can be represented on a refrigerant circuit schematic on the display.

Via pop-up menus, detailed information on various components of the heat pump can be called up.

Any alarms are displayed. All measured values are continuously monitored by the control in real time. Interfaces for remote maintenance or a higher level BMS are available.

### Controller functions/safety functions

- Long-term recording of operating conditions
- Hours run counter for compressor
- Monitoring of minimum compressor downtime and runtime
- Actuation of solenoid valves for output control
- Management of actuated component alarms
- Heating/cooling mode changeover

### Temperature control

The heat pump can provide various temperatures at the condenser or evaporator outlet depending on demand. The following options are available for such temperature requirements:

- Fixed target value
- 0-10 V analogue input
- 4-20 mA analogue input

### Operating modes

The heat pump can be used for the following operating modes:

- Heating mode with monitoring of condenser outlet temperature
- Cooling mode with monitoring of evaporator outlet temperature

Additional functions can be implemented on the control (on request):

- Power supply and actuation of the circulation pumps for heat source and/or user loop
- Buffer tank control strategy (DHW)
- Power supply and actuation of the 3-way mixing valves on the evaporator and/or condenser

### Frame

Special emphasis is placed on a robust, space saving and economical design. The heat pump components are mounted on a base frame and on the shell and tube heat exchangers, where they are partly self-supporting. Rubber/metal vibration dampers matched to the weight of the heat pump reliably isolate the heat pump from the installation location and therefore prevent structure-borne noise transmission to the foundations.



## PHYSICAL DATA

### 61CW-D : Up to 95°C Water to Water - Very High Temperature Industrial Heat Pumps

Unit		61CW-D130	61CW-D190	61CW-D240	61CW-D320	61CW-D540
<b>Performance data<sup>(1)</sup></b>						
Heating Capacity	kW	129,0	186,0	236,0	319,0	536,0
Cooling Capacity	kW	112,0	162,0	203,0	271,0	454,0
Power Consumption	W45/W85 kW	26,9	36,4	44,8	61,4	107,6
Coefficient of Performance	-	4,8	5,1	5,3	5,2	5,0
Drawn Current	A	63,9	68,3	93,4	120,6	204,2
Heating Capacity	kW	121	175	225	303	489
Cooling Capacity	kW	98	142	180	240	383
Power Consumption	W45/W95 kW	34,4	46,6	57,0	77,8	137,4
Coefficient of Performance	-	3,5	3,8	3,9	3,9	3,6
Drawn Current	A	71,9	81,4	108,4	140,8	245,8
<b>Technical data</b>						
Dimensions (LxWxH) <sup>(2)</sup>	mm	3700 x 1400 x 1800	3700 x 1500 x 1900	4000 x 1700 x 2000	4100 x 1800 x 2000	4300 x 1900 x 2100
Weight <sup>(2)</sup>	kg	2000	2200	2500	3200	4000
Refrigerant	-	R1233zd (GWP=4,5 following AR4, ODP=0)				
Refrigerant charge <sup>(2)</sup>	kg	65	75	90	115	150
	teqCO <sub>2</sub>	0,3	0,3	0,4	0,5	0,7
Voltage / Frequency	V/Hz	400/50				
Rotor starting current PW D/DD	A	495/770	-	-	-	-
Rotor starting current Y/Δ	A	-	354/1155	453/1333	595/1802	1062/3186
Max. Operating current	A	168	225	270	400	650
<b>Compressor</b>						
Quantity	-	1				
Type	-	Fixed-speed screw compressor				
<b>Evaporator</b>						
Temperature Difference <sup>(3)</sup>	K	5	5	5	5	5
Water flow <sup>(3)</sup>	m <sup>3</sup> /h	19,5	28,2	35,3	47,1	78,9
Fluid type	-	Water				
Operating range - Inlet temperature <sup>(3)</sup>	°C	+35/+60				
Min. operating pressure <sup>(3)</sup>	bar	1,0				
Max. operating pressure <sup>(3)</sup>	bar	10,0				
<b>Condenser</b>						
Temperature Difference <sup>(3)</sup>	K	5	5	5	5	5
Water flow <sup>(3)</sup>	m <sup>3</sup> /h	22,8	32,9	41,7	56,4	94,8
Fluid type	-	Water				
Operating range - Outlet temperature <sup>(3)</sup>	°C	+75/+95				
Min. operating pressure <sup>(3)</sup>	bar	2,0				
Max. operating pressure <sup>(3)</sup>	bar	10,0				

(1) Technical data with tolerance ±10%

(2) Reference values; the main dimensions/mass depends on the operating points and the calculated heat exchangers

(3) Data at W45/W85

Pressure drop as well as the minimum and maximum flow rate of the evaporator and the condenser will be calculated customized after order intake.

## PHYSICAL DATA

### 61CWTD : Up to 120°C Water to Water - Ultra High Temperature Industrial Heat Pumps

Unit		61CWTD110	61CWTD160	61CWTD210	61CWTD280	61CWTD430
<b>Performance data<sup>(1)</sup></b>						
Heating Capacity	kW	109,0	159,0	212,0	284,0	429,0
Cooling Capacity	kW	76,0	112,0	145,0	191,0	280,0
Power Consumption	W45/W110 kW	46,7	63,3	83,0	108,0	185,4
Coefficient of Performance	-	2,3	2,5	2,6	2,6	2,3
Drawn Current	A	86,7	104,2	134,0	177,0	315,0
Heating Capacity	kW	107	156,0	209,0	280,0	403,0
Cooling Capacity	kW	70,0	103,0	135,0	177,0	251,0
Power Consumption	W45/W118 kW	50,9	69,0	89,0	120,0	196,0
Coefficient of Performance	-	2,1	2,3	2,3	2,3	2,1
Drawn Current	A	92,2	112,4	143,1	189,7	339,7
<b>Technical data</b>						
Dimensions (LxWxH) <sup>(2)</sup>	mm	3700 x 1400 x 1800	3700 x 1500 x 1900	4000 x 1700 x 2000	4100 x 1800 x 2000	4300 x 1900 x 2100
Weight <sup>(2)</sup>	kg	2000	2200	2500	3200	4000
Refrigerant	-	R1233zd (GWP=4,5 following AR4, ODP=0)				
Refrigerant charge <sup>(2)</sup>	kg	65	75	90	115	150
	teqCO <sub>2</sub>	0,3	0,3	0,4	0,5	0,7
Voltage / Frequency	V/Hz					
Rotor starting current PW D/DD	A	495/770	-	-	-	-
Rotor starting current Y/Δ	A	-	354/1155	453/1333	595/1802	1062/3186
Max. Operating current	A	168	225	270	400	650
<b>Compressor</b>						
Quantity		1				
Type		Fixed-speed screw compressor				
<b>Evaporator</b>						
Temperature Difference <sup>(3)</sup>	K	5	5	5	5	5
Water flow <sup>(3)</sup>	m <sup>3</sup> /h	13,2	19,5	25,2	33,2	48,7
Fluid type	-	Water				
Operating range - Inlet temperature <sup>(3)</sup>	°C	+35/+60				
Min. operating pressure <sup>(3)</sup>	bar	1,0				
Max. operating pressure <sup>(3)</sup>	bar	10,0				
<b>Condenser</b>						
Temperature Difference <sup>(3)</sup>	K	5	5	5	5	5
Water flow <sup>(3)</sup>	m <sup>3</sup> /h	19,5	28,4	37,9	50,8	76,7
Fluid type	-	Water				
Operating range - Outlet temperature <sup>(3)</sup>	°C	+75/+120				
Min. operating pressure <sup>(3)</sup>	bar	5,0				
Max. operating pressure <sup>(3)</sup>	bar	16,0				

(1) Performance data with tolerance ±10%

(2) Reference values; the main dimensions/mass depends on the operating points and the calculated heat exchangers

(3) Data at W45/W110

Pressure drop as well as the minimum and maximum flow rate of the evaporator and the condenser will be calculated customized after order intake.

## OPERATING MAP

### Operating limits

#### Ultra High Temperature Heat Pump with ECO Heat source water / brine

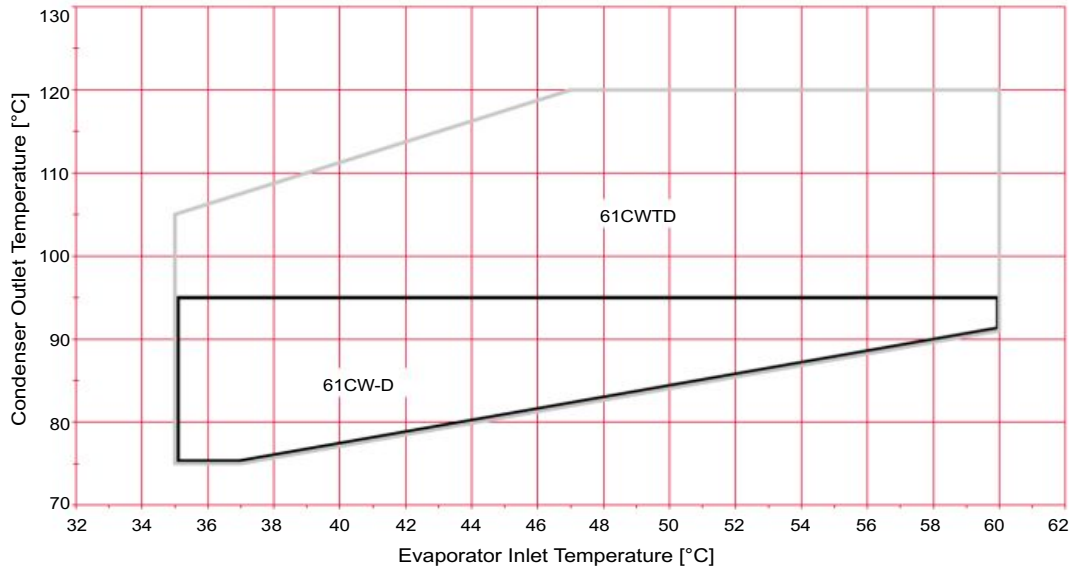

— 61CW-D  
— 61CWTD  
Evaporator  $\Delta T=5K$   
Condenser  $\Delta T=5K$

The limits of use defined in the operating map above represents the switch-off values of the heat pump.  
We recommend a maximum hot water set-point 2°C below the switch-off value for optimized heat pump operation.

## OPTIONS

Options	N°	Description	Advantages	Aquaforce 61CW-D (up to 95°C)	Aquaforce 61CWTD (up to 120°C)
Softstarter	25	Electronic starter on each compressor	Reduced start-up current	130-540	110 - 430
Modbus interface (RS 485)	149B	Unit control compatible with the bus interface RS485 Modbus RTU. Other bus interfaces on request	The heat pump control unit with communication capability is easily integrated into the building management system	130-540	110 - 430
Gas detector (kit)	159C	Unit equipped with refrigerant leak detector Alarms are visual and acoustic. Regular checking of the gas detector is not included in the offer	Immediate customer notification of refrigerant losses to the atmosphere, allowing timely corrective actions	130-540	110 - 430
Remote access	275	The touchscreen has two 10/100 Mbit Ethernet ports (RJ45) with an integral switch. Using an Ethernet patch cable, the touchscreen can be connected to the customer company network. The operator/customer must provide a secure VPN tunnel to the customer network.	Allow remote control & Check of the unit and its operating parameters from anywhere in the world and to change/optimize any settings.	130-540	110 - 430
Sound enclosure	258	Complete enclosure for effective sound insulation of the heat pump at the installation site. Self-supporting aluminium sheet elements, filled with sound absorbing mineral wool and connected with quick-release clamps. Enclosure can be dismantled into individual parts. The individual elements have rubber elements to decouple structure-borne noise. Must be installed on a flat surface. Exclusive installation of the sound insulating enclosure at the installation site.	Sound pressure level reduction by approx. 10 -15 dB(A) Fire behaviour according to EN 13501-1: class A1, non-flammable, no flammable components.	130-540	-
Electric energy meter	294	Display of energy consumption of the unit, instantaneous (U, V, I) and cumulated (kWh) of the unit	Permits the acquisition & monitoring of energy used.	130-540	110 - 430

## DIMENSIONAL DRAWINGS

### 61CW-D : Up to 95°C

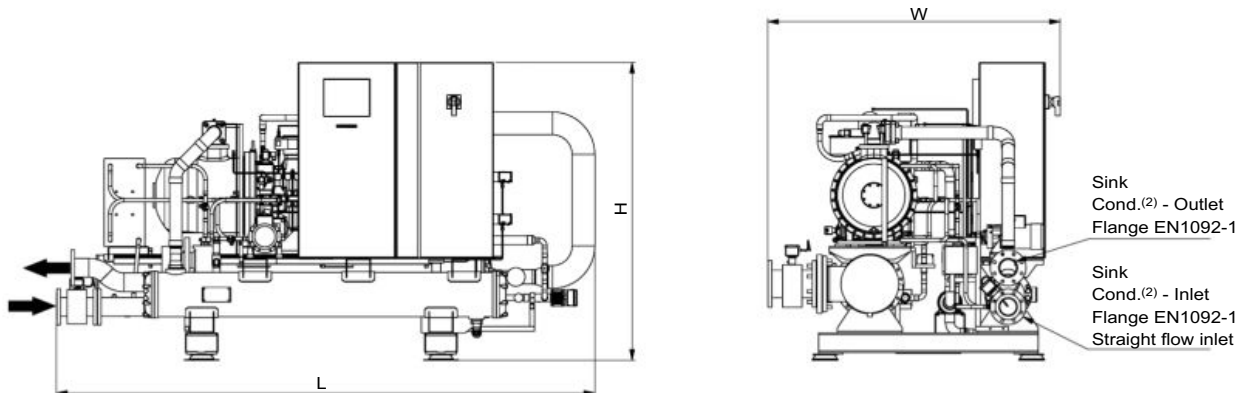

#### Types 61CW-D130 / 61CWD-190 / 61CW-D240 / 61CW-D320

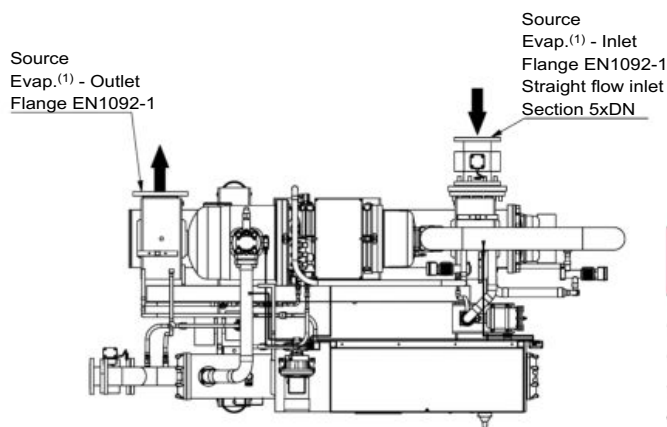

Type	L	W	H	Evap. in	Evap. out	Cond. in	Cond. out
61CW-D130	3300	1650	1800	DN100	DN100	DN65	DN65
61CW-D190	3350	1850	1800	DN150	DN200	DN100	DN100
61CW-D240	3950	1750	1800	DN150	DN200	DN100	DN100
61CW-D320	4450	2050	1900	DN150	DN200	DN100	DN125

#### Type 61CW-D540

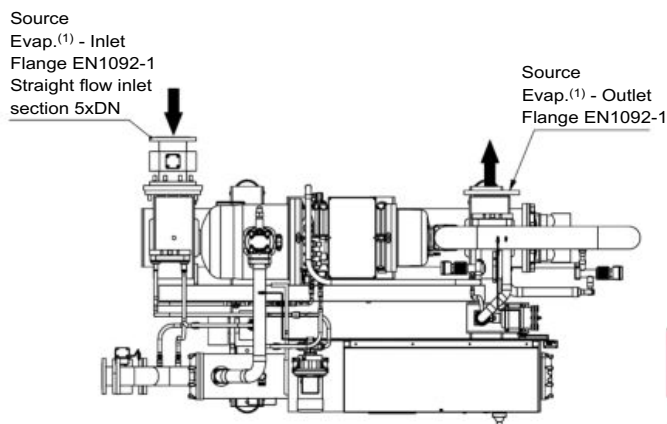

Type	L	W	H	Evap. in	Evap. out	Cond. in	Cond. out
61CW-D540	4600	2050	2000	DN150	DN200	DN150	DN150

## DIMENSIONAL DRAWINGS

61CWTD : Up to 120°C

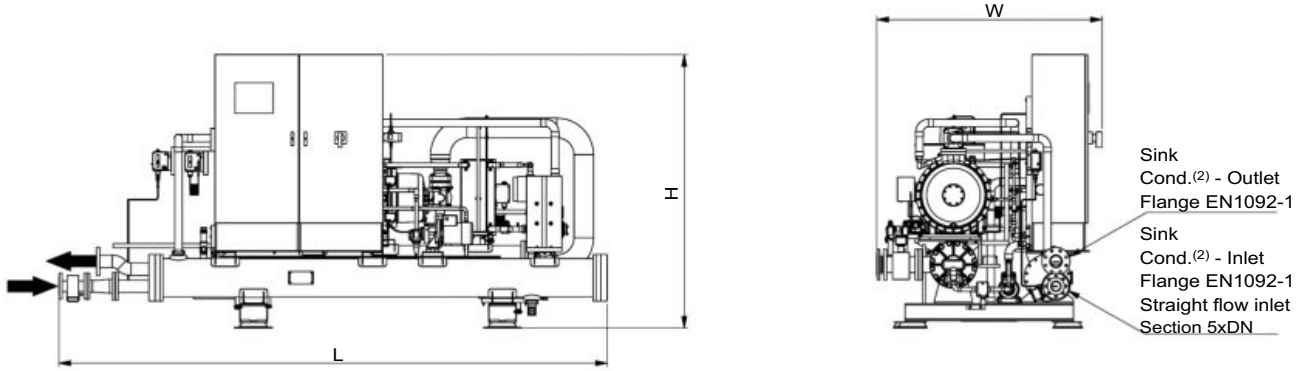

Types 61CWTD110 / 61CWTD160 / 61CWTD210 / 61CWTD280

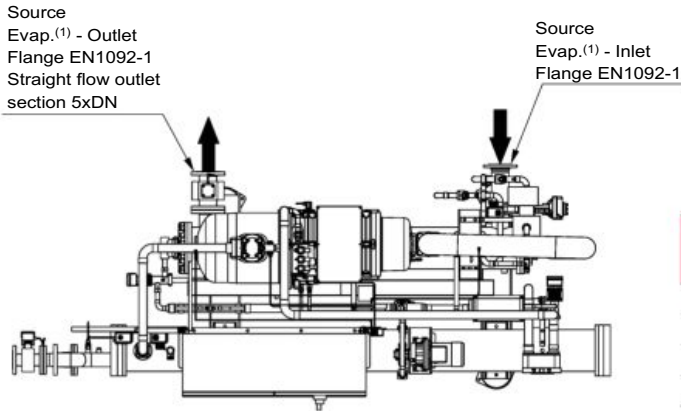

Type	L	W	H	Evap. in	Evap. out	Cond. in	Cond. out
61CW-D110	3300	1650	1800	DN100	DN100	DN65	DN65
61CW-D160	3350	1850	1800	DN150	DN150	DN100	DN100
61CW-D210	3950	1750	1800	DN150	DN150	DN100	DN100
61CW-D280	4450	2050	1900	DN150	DN150	DN100	DN125

Type 61CWTD430

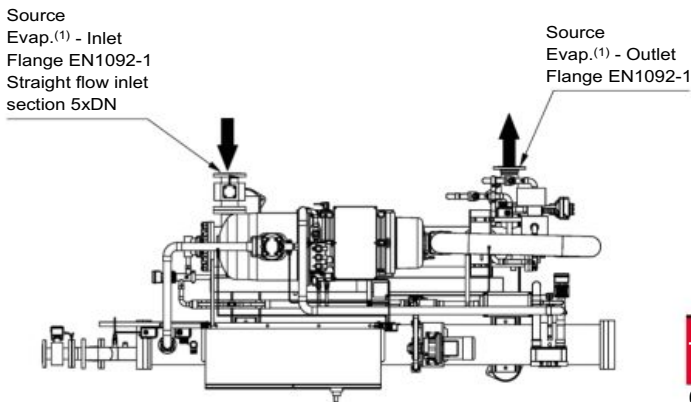

Type	L	W	H	Evap. in	Evap. out	Cond. in	Cond. out
61CW-D430	4950	2050	2000	DN150	DN150	DN150	DN150



## COMPLETE CARRIER RANGES OF HIGH TEMPERATURE HEAT PUMP FOR COMMERCIAL APPLICATIONS UP TO 82°C

### AquaSnap 61CG



High temperature  
water source heat pumps  
30 to 130 kW  
Hot water up to 82°C

### AquaSnap 61WG



High temperature  
water source heat pumps  
20 to 190 kW  
Hot water up to 65°C

### AquaSnap 61AF



High temperature  
air source heat pumps  
22 to 105 kW  
Hot water up to 65°C

## COMPLETE CARRIER RANGES OF HIGH TEMPERATURE INDUSTRIAL HEAT PUMP FOR DISTRICT HEATING AND PROCESS APPLICATIONS UP TO 120°C

### AQUAFORCE 61CA

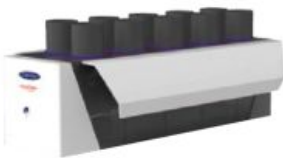

High temperature  
air source heat pumps  
410 kW  
Hot water up to 82°C

### AQUAFORCE 61XWHZE



High temperature  
water source heat pumps  
300 to 1570 kW  
Hot water up to 85°C

### AQUAFORCE 61CW-Z



Very high temperature  
water source heat pumps  
410 kW to 735 kW  
Hot water up to 92°C

### AQUAFORCE 61CWD



Ultra high temperature  
water source heat pumps  
110 kW to 540 kW  
Hot water up to 120°C



**NEW**

## VERY HIGH TEMPERATURE WATER SOURCE HEAT PUMP



# 61CW-Z

Nominal heating capacity 410 to 735 kW

### APPLICATION RANGES

- Industrial process heating
- District heating networks
- Heat source: water or brine from process heat or heat recovery

### DESIGN

- Ultra low GWP R1234ze refrigerant
- Screw compressors specially designed for high temperatures for heavy-duty continuous use
- Cooling system with internal circuit
- Robust shell and tube heat exchangers

### OUTPUT RANGE

- Heating output from 410 kW to 735 kW at W30/W90, as TWIN unit up to 1.5 MW

## AQUAFORCE.



## TECHNICAL INSIGHT

### Compressor

CARRIER high temperature industrial heat pumps are fitted with a semi-hermetic screw compressor specially designed for use in heat pumps with high system temperatures. With a newly developed, asymmetrical high-performance profile, these twin shaft rotation displacement machines achieve the highest levels of efficiency and maximum service life in continuous use.

With no oscillating components, they operate with very low vibrations and virtually no wear. The roller bearings are specially designed for high temperatures and sized to ensure an extremely long service life.

A high degree of operational reliability is guaranteed by means of forced lubrication, and through an integral three-stage oil separator and sump heater on the pressure side. The oil heater ensures the lubricating properties of the oil even after long downtimes. A separate cooling circuit with its own oil pumps and water-cooled oil cooler ensures the required oil temperature and/or correct bearing lubrication at high operating temperatures.

The compressor casing includes a three phase asynchronous motor. The motor armature is mounted on the shaft of the main screw rotor. It is cooled with cold refrigerant vapour. The motor winding is designed especially for the specified temperature conditions. The screw compressors are fitted with a star-delta circuit to reduce the starting current.

### Heat exchanger

Evaporators and condensers are used as generously sized shell and tube heat exchangers based on the counterflow principle. Shell and tube heat exchangers ensure reliability and robust operation even under difficult conditions. The design of the heat exchangers has been optimised to ensure the maximum possible transfer capacity along with the smallest possible pressure loss and minimum space requirement. The heat exchangers are not sensitive to fouling and, due to their cylindrical shape, are resistant to pressure shock. The heat exchangers are fitted with flange connections.

### Refrigerant circuit/refrigerant

The refrigerant circuit is filled with a non-combustible and non-toxic safety refrigerant. The refrigerant used is CFC-free and is therefore fully futureproof. The refrigerant charge is optimised for the highest possible coefficient of performance (COP). The refrigerant circuit undergoes a pressure and leakage test using helium or forming gas.

### Safety equipment

To maximise the service life of the system, particular attention has been paid to the operational reliability of the heat pump and to protecting the compressor.

#### Compressor protection device

CARRIER industrial heat pumps are equipped with a protection device for the screw compressor as standard. The protection device is built into the compressor connection box and is fully wired. It monitors:

- Motor and oil temperatures
- Rotational direction
- Phase failure

#### Additional safety equipment

- Motor protection switch for the compressor
- Overpressure safety valve in the refrigerant circuit
- High and low pressure sensors in the refrigerant circuit for electronic monitoring of the limits of use
- Oil level monitor
- Double high pressure controller
- Hot gas sensor/monitoring of compressor outlet temperature
- Flow monitor on the evaporator and condenser
- Flow switch in oil cooling circuit

### Electrical cabinet

The control cabinet of the heat pump is mounted on the long side of the heat pump and contains the power and control unit. The customer receives fully wired electrical equipment that is ready for operation according to the international standard.

Designed with IP 54 protection rating. The heat pump requires a 3x400 V (without neutral conductor) and 1x230 V connections.

The power unit includes:

- Switching elements for the compressor: contactors for part winding or star/delta start
- Contactors for source and sink circulation pumps, depending on requirements of installation overcurrent protection devices, motor protection devices, lockable main switch, transformer for 24 V control circuit, control of solenoid valves and expansion valves, designated terminal strips with inputs and outputs for connection to the BMS (outputs potential-free).

## TECHNICAL INSIGHT

### Control unit

The hardware of the control unit comprises a programmable logic controller (PLC) and a Human Machine Interface (HMI). The software for the control unit was developed especially for 61CW-Z and processes the necessary number of inputs and outputs for controlling the refrigerant circuit.

The control also performs all non-mechanical safety functions of the refrigerant circuit, e.g.: frost protection alarm or field rotation monitoring on the compressor motor.

The HMI has a 10" touchscreen for entering control commands, target values and parameters. For visualisation of system statuses and actual values, these can be represented on a refrigerant circuit schematic on the display.

Via pop-up menus, detailed information on various components of the heat pump can be called up.

Any alarms are displayed. All measured values are continuously monitored by the control in real time. Interfaces for remote maintenance or a higher level BMS are available.

### Controller functions/safety functions

- Long-term recording of operating conditions
- Hours run counter for compressor
- Monitoring of minimum compressor downtime and runtime
- Actuation of solenoid valves for output control
- Management of actuated component alarms
- Heating/cooling mode changeover

### Temperature control

The heat pump can provide various temperatures at the condenser or evaporator outlet depending on demand. The following options are available for such temperature requirements:

- Fixed target value
- 0-10 V analogue input
- 4-20 mA analogue input

### Operating modes

The heat pump can be used for the following operating modes:

- Heating mode with monitoring of condenser outlet temperature
- Cooling mode with monitoring of evaporator outlet temperature

Additional functions can be implemented on the control (on request):

- Power supply and actuation of the circulation pumps for heat source and/or user loop
- Buffer tank control strategy (DHW)
- Power supply and actuation of the 3-way mixing valves on the evaporator and/or condenser

### Frame

Special emphasis is placed on a robust, space saving and economical design. The heat pump components are mounted on a base frame and on the shell and tube heat exchangers, where they are partly self-supporting. Rubber/metal vibration dampers matched to the weight of the heat pump reliably isolate the heat pump from the installation location and therefore prevent structure-borne noise transmission to the foundations.

On request, the heat pump can be equipped with a complete SOUND INSULATING ENCLOSURE.



## PHYSICAL DATA

### Single Stage Water to Water - Highest Temperature Industrial Heat Pumps

Unit		61CW-Z392	61CW-Z472	61CW-Z572	61CW-Z742
<b>Performance data<sup>(1)</sup></b>					
Heating Capacity	kW	294,0	336,0	433,0	524,0
Cooling Capacity	kW	184,0	209,0	277,0	336,0
Power Consumption	W10/W75 kW	110,0	127,0	156,0	188,0
Coefficient of Performance	-	2,7	2,6	2,8	2,8
Drawn Current	A	177,6	206,7	252,6	304,5
Heating Capacity	kW	408,0	467,0	604,0	736,0
Cooling Capacity	W29/ W90 kW	262	294,0	399,0	481,0
Power Consumption	W29/ W90 kW	146,0	173,0	205,0	255,0
Coefficient of Performance	-	2,8	2,7	2,9	2,9
Drawn Current	A	235,9	279,9	332,4	413,5
<b>Technical data</b>					
Dimensions (LxWxH) <sup>(2)</sup>	mm	4050 x 1900 x 1900	4450 x 2050 x 2000	4450 x 2000 x 2000	4650 x 2050 x 2000
Weight <sup>(2)</sup>	kg	3200	3600	4000	4800
Refrigerant	-	R1234ze (GWP=7 following AR4, ODP=0)			
Refrigerant charge <sup>(2)</sup>	kg	125	160	180	200
	teqCO <sub>2</sub>	0,9	1,1	1,3	1,4
Voltage/ Frequency	V/Hz	400/50	400/50	400/50	400/50
Rotor starting current Y/Δ	A	558/1675	558/1675	875/2625	875/2625
Max. Operating current	A	310	380	450	580
<b>Compressor</b>					
Quantity	-	1			
Type	-	Fixed-speed screw compressor			
<b>Evaporator</b>					
Temperature difference <sup>(3)</sup>	K	5	5	5	5
Water flow <sup>(3)</sup>	m <sup>3</sup> /h	31,5	35,8	47,5	57,6
Internal pressure drop <sup>(3)</sup>	mbar	310,0	300,0	300,0	340,0
Fluid type	-	Water			
Minimum flow rate	m <sup>3</sup> /h	19,3	21,8	27,3	31,1
Maximum flow rate	m <sup>3</sup> /h	75,1	83,7	108,3	126,8
Operating range	°C	+8/+29			
Min. operating pressure	bar	1,0			
Max. operating pressure	bar	10,0			
<b>Condenser</b>					
Temperature difference <sup>(3)</sup>	K	5	5	5	5
Water flow <sup>(3)</sup>	m <sup>3</sup> /h	51,7	59,1	76,2	92,2
Internal pressure drop <sup>(3)</sup>	mbar	310,0	290,0	280,0	270,0
Fluid type	-	Water			
Minimum flow rate	m <sup>3</sup> /h	32,7	38,3	50,8	62,6
Maximum flow rate	m <sup>3</sup> /h	81,8	95,7	127,0	156,6
Operating range	°C	+45/+92			
Min. operating pressure	bar	2,0			
Max. operating pressure	bar	16,0			

(1) Technical data with tolerance ±10%

(2) Reference values; the main dimensions/mass depends on the operating points and the calculated heat exchangers

(3) Data at W10/W75

Pressure drop as well as the minimum and maximum flow rate of the evaporator and the condenser will be calculated customized after order intake.

## OPERATING MAP

### Operating limits

**High Temperature Heat Pump with ECO**  
Heat source water / brine

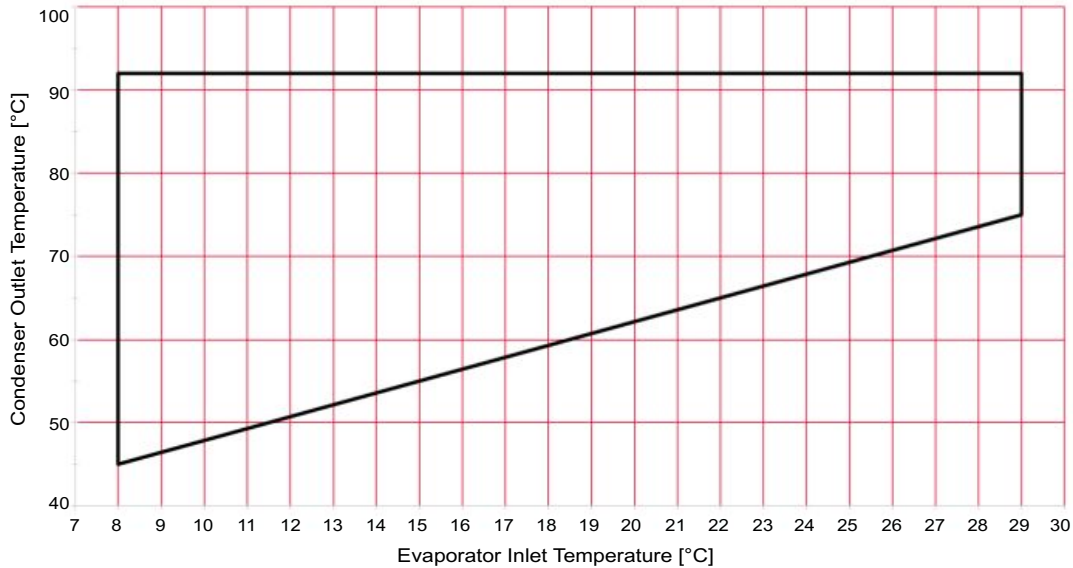

Evaporator  $\Delta T=4K$

Condenser  $\Delta T=5K$

The limits of use defined in the operating map above represents the switch-off values of the heat pump.

We recommend a maximum hot water set-point 2°C below the switch-off value for optimized heat pump operation.

## OPTIONS

Options	N°	Description	Advantages	Aquaforce 61CW-Z
Softstarter	25	Electronic starter on each compressor	Reduced start-up current	392-742
Modbus interface (RS 485)	149B	Unit control compatible with the bus interface RS485 Modbus RTU. Other bus interfaces on request	The heat pump control unit with communication capability is easily integrated into the building management system	392-742
Gas detector (kit)	159C	Unit equipped with refrigerant leak detector Alarms are visual and acoustic. Regular checking of the gas detector is not included in the offer	Immediate customer notification of refrigerant losses to the atmosphere, allowing timely corrective actions	392-742
Remote access	275	The touchscreen has two 10/100 Mbit. Ethernet ports (RJ45) with an integral switch. Using an Ethernet patch cable, the touchscreen can be connected to the customer company network. The operator/ customer must provide a secure VPN tunnel to the customer network.	Allow remote control & Check of the unit and its operating parameters from anywhere in the world and to change/ optimise any settings.	392-742
Compressor acoustic enclosure	257	Compressor sound enclosure	Efficient reduction in sound emissions across the entire frequency range Noise level reduction approx. 8 dB(A)	392-742
Sound enclosure	258	Complete enclosure for effective sound insulation of the heat pump at the installation site. Self-supporting aluminium sheet elements, filled with sound absorbing mineral wool and connected with quick-release clamps. Enclosure can be dismantled into individual parts. The individual elements have rubber elements to decouple structure-borne noise. Must be installed on a flat surface. Exclusive installation of the sound insulating enclosure at the installation site.	Sound pressure level reduction by approx. 10 -15 dB(A) Fire behaviour according to EN 13501-1: class A1, non-flammable, no flammable components.	392-742
Electric energy meter	294	Display of energy consumption of the unit, instantaneous (U, V, I) and cumulated (kWh) of the unit	Permits the acquisition & monitoring of energy used.	392-742

**DIMENSIONAL DRAWINGS**

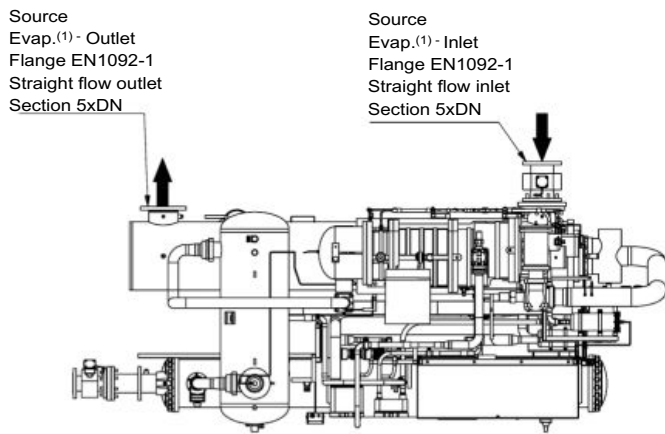
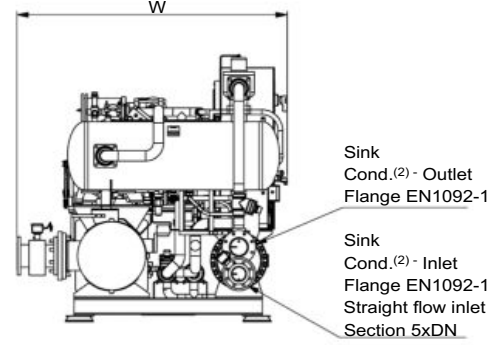
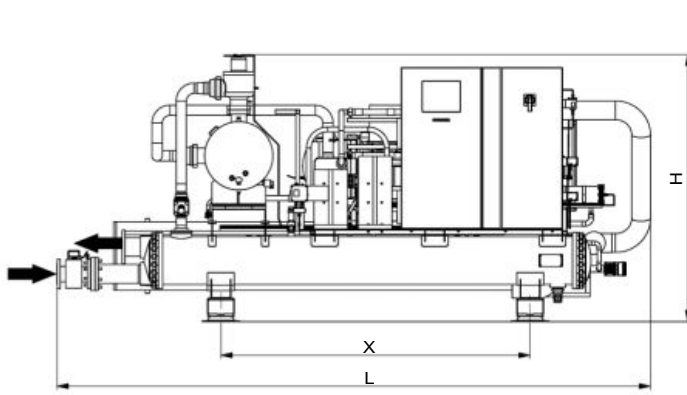

Type	L	W	H	X	Evap. in	Evap. out	Cond. in	Cond. out
61CW-Z392	4050	1900	1900	2190	DN150	DN200	DN100	DN100
61CW-Z472	4450	2050	2000	2300	DN150	DN200	DN100	DN125
61CW-Z572	4450	2000	2000	2300	DN150	DN200	DN100	DN125
61CW-Z742	4650	2050	2000	2300	DN150	DN200	DN150	DN150

## COMPLETE CARRIER RANGES OF HIGH TEMPERATURE HEAT PUMP FOR COMMERCIAL APPLICATIONS UP TO 82°C

### AquaSnap 61CG



High temperature  
water source heat pumps  
30 to 130 kW  
Hot water up to 82°C

### AquaSnap 61WG



High temperature  
water source heat pumps  
20 to 190 kW  
Hot water up to 65°C

### AquaSnap 61AF



High temperature  
air source heat pumps  
22 to 105 kW  
Hot water up to 65°C

## COMPLETE CARRIER RANGES OF HIGH TEMPERATURE INDUSTRIAL HEAT PUMP FOR DISTRICT HEATING AND PROCESS APPLICATIONS UP TO 120°C

### AQUAFORCE 61CA

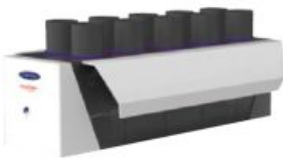

High temperature  
air source heat pumps  
410 kW  
Hot water up to 82°C

### AQUAFORCE 61XWHZE



High temperature  
water source heat pumps  
300 to 1570 kW  
Hot water up to 85°C

### AQUAFORCE 61CW-Z



Very high temperature  
water source heat pumps  
410 kW to 735 kW  
Hot water up to 92°C

### AQUAFORCE 61CWD



Ultra high temperature  
water source heat pumps  
110 kW to 540 kW  
Hot water up to 120°C





## HIGH TEMPERATURE WATER-SOURCE HEAT PUMP



Renewable heat solution able to produce hot water up to 85°C

Multiple applications: district heating, space heating, process heating

Multiple renewable energy sources: waste heat from data centers, from industry, grey waters, ground source water

61XWHLZE  
61XWH-ZE  
61XWHHZE

**AQUAFORCE**  
PUREtec

Nominal heating capacity 300-1570 kW

The AQUAFORCE PUREtec 61XWHZE water-source heat pumps are the premium solution for industrial and commercial heating applications where end users, consultants and building owners require optimal performances, very hot water temperature, environmental solution and maximum reliability.

The AQUAFORCE PUREtec 61XWHZE water-source heat pumps are designed to meet current and future requirements in terms of energy efficiency, flexibility of use and compactness.

They use the most reliable technologies available today:

- Twin-rotor screw compressors with a variable capacity valve
- R-1234ze refrigerant
- Touch Pilot control system
- Flooded heat exchangers that are mechanically cleanable

The 61XWHZE Aquaforce range is available into three versions:

- 61XWHLZE for low heat source temperatures
- 61XWH-ZE for medium heat source temperatures
- 61XWHHZE for high heat source temperatures

## INTRODUCTION

Forecasts indicate that 75% of the European citizens will live in urban areas in 2020 and that this share will increase to 84% by 2050. People in cities use three times as much energy as people who live in the country. This has tremendous implications for the environment today and in the future if we do nothing.

Recent European surveys have demonstrated that there is enough waste heat produced in the European Union to heat the entire building stock. Industrial waste heat, waste heat from grey waters, waste heat from process cooling, data centers... All this waste energy too frequently released into the air or into water bodies.

More and more, developers, consultants, cities, politics will need to imagine intelligent, sustainable cities with smart heating and cooling solutions. More and more industrial end users will need to imagine new solutions to value waste heat from industrial processes.

Heat pumps have been already used to such purpose for many years.

More recently CARRIER has supported customers across various markets on big projects like data centers, hospitals, schools, district heating with large heat-pumps using HFC 134a.

### Higher with PUREtec

Now the combination of Carrier technology and HFO refrigerant enables to offer high temperature PUREtec heat pumps capable of delivering hot water up to 85°C!

The AQUAFORCE PUREtec 61XWHZE water-source heat pumps can recover, upgrade and value the waste heat for reuse in applications like local or district heating. Selecting the 61XWHZE, you can now have an alternative and complement as traditional boiler in applications such as district heating or industrial processes.

While the boilers are heating only, 61XWHZE heat-pumps can provide heating, cooling and transfer energy from waste energy with much higher energy efficiency performance ratios than boilers.

The AQUAFORCE PUREtec 61XWHZE water-source heat pumps are the premium solution for industrial and commercial heating applications where installers, consultants and building owners require optimal performances hot water temperature, environmental solution, maximum reliability and safety.

The AQUAFORCE PUREtec 61XWHZE water-source heat pumps are designed to meet current and future requirements in terms of energy efficiency, flexibility of use and compactness. They use the most reliable technologies available today:

- Twin-rotor screw compressors with a variable capacity valve
- R-1234ze refrigerant
- Touch Pilot control system
- Flooded heat exchangers that are mechanically cleanable

## Customer Benefits

### Renewable Heat Solution

- The perfect solution for district heating systems
  - The 61XWHZE contribute both towards the EU 2020 ambition of 27% energy mix coming from renewable sources and the expansion of district heating from the present level of around 12% to 50% in 2050 in EU.
  - Multiple 61XWHZE high temperature water-source heat pumps can be combined to reach the best efficiency and higher capacities.
  - The district heating networks using 61XWHZE high temperature water-source heat pumps are being illegible for financial incentives in many countries.
- The perfect solution for smart cities
  - The 61XWHZE high temperature water-source heat pumps can recover energy from industrial process wasted heat, IT cooling systems, grey waters, to produce very hot water up to 85°C to supply residential buildings, commercial buildings, hotels, hospitals, public offices, schools, industries located in the district.
- The perfect solution for process heating and facilities space heating
  - The 61XWHZE high temperature water-source heat pumps can be used in the industrial sector to recover, upgrade and value any water stream up to 55°C as a source to higher temperature levels of 85°C which make it attractive for several usages. Some examples are the heat removed from electrical motors, industrial machines, paper industry, steel industry, non-metallic industry (glass, cement, tile, brick, food, beverage), chemical industries or also facilities space heating.

### Low energy consumption

- Renewable energy source to comply with EU 2020 targets (27% of renewable energy)
- No need for a gas network
- The heat pump technology is more efficient and sustainable than any fossil fuel combustion system.
- 61XWHZE achieves great Coefficient Of Performance (COP of 6 or more), with very low carbon impact when compared with traditional boilers.
- The high energy efficiency is reached through:
  - Twin-rotor screw carrier compressor equipped with a high-efficiency motor and a variable capacity valve that permits exact matching of the heating capacity to the load.
  - Flooded multi-pipe heat exchangers for increased heat exchange efficiency.
  - Electronic expansion device permitting improved utilisation of the evaporator heat exchange surface.
  - Economizer system with electronic expansion device for increased heating/cooling capacity.

### Low sound level

- Standard unit features include:
  - Silencers on the compressors discharge line.
  - Silencers on the economiser return line.
  - Acoustic insulation on the components that are most subjected to radiated noise.
  - Specific attenuation possible upon request.

## INTRODUCTION

### Easy and fast installation

- The 61XWHZE units just need an electrical connection and a water source.
- Compact design
  - The 61XWHZE water-source heat pumps are designed to offer the most compact dimensions on the market.
  - With a width of less than 1.4 m up to 2500 kW the units can pass through standard door openings and only require minimum floor space in the plant room.

Compact, accessible unit - side view

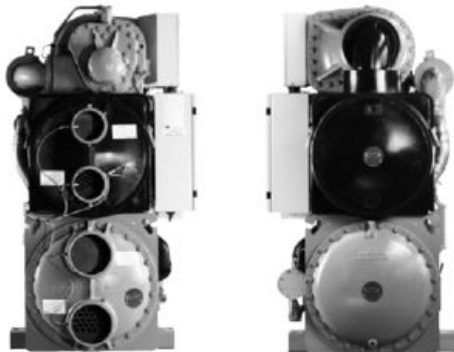

- Simplified electrical connections
  - Main disconnect switch with high trip capacity
  - Transformer to supply the integrated control circuit (400/24 V)
- Simplified hydronic connections
  - Victaulic connections on the evaporator and condenser
  - Practical reference marks for entering and leaving water connections
  - Possibility to reverse the heat exchanger water inlet and outlet at the factory
  - Possibility to modify the number of heat exchanger passes
- Fast commissioning
  - Systematic factory operation test before shipment
  - Quick-test function for step-by-step verification of the instruments, expansion devices and compressors.

### Environmental care



- R-1234ze long-term refrigerant solution
  - HFO refrigerant with nearly zero global warming potential (GWP < 1) and zero ozone depletion potential (ODP = 0).
  - Not impacted by the HFC phase-down plan in Europe (79% HFC reduction in EU member states at 2030 horizon)
  - Compliant with refrigerant regulation in Switzerland that bans the use of HFC refrigerant in large capacity air-conditioning equipment.
- Leak-tight refrigerant circuit
  - Reduction of leaks as no capillary tubes and flare connections are used
  - Verification of pressure transducers and temperature sensors without transferring refrigerant charge
  - Discharge line shut-off valve and liquid line service valve for simplified maintenance.

### High reliability and easy servicing

- The 61XWHZE water-source heat pumps offer increased global performance as well as Carrier's acclaimed product quality and reliability.
- Major components are selected and tested with R-1234ze refrigerant to minimize failures possibility, as well as many design choices have been taken in this perspective.
- Screw compressors
  - Industrial-type screw compressors with oversized bearings and motor cooled by suction gas.
  - All compressor components are easily accessible on site minimising down-time.
- Refrigerant circuit
  - One or two independent refrigerant circuits the second one automatically takes over, if the first one develops a fault, maintaining partial cooling under all circumstances.
- Evaporator
  - Electronic paddle-free flow switch. Auto-setting according to cooler size and fluid type.
- Auto-adaptive control
  - Control algorithm prevents excessive compressor cycling (Carrier patent)
  - Automatic compressor unloading in case of abnormally high condensing pressure.
- Exceptional endurance tests
  - Partnerships with specialised laboratories and use of limit simulation tools (finite element calculation) for the design of critical components.
  - Transport simulation test in the laboratory on a vibrating table and then on an endurance circuit (based on a military standard).

### Safe Design Carrier

- Specific compressor gaskets compatible with HFO-1234ze, tested and validated.
- New relief valves designed for operation with HFO-1234ze and high temperature
- Specific electrical box with increased tightness and integrated blower that maintains positive air pressure to avoid any risk of ignition.
- New control algorithms
- Specific documentation that contains all the installation, operation, maintenance and safety Instructions.

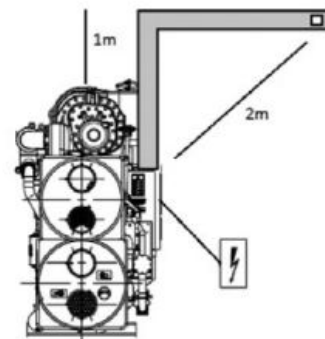

## INTRODUCTION

### Technical insights

#### Touch Pilot Control

##### Touch Pilot control, 5" user interface

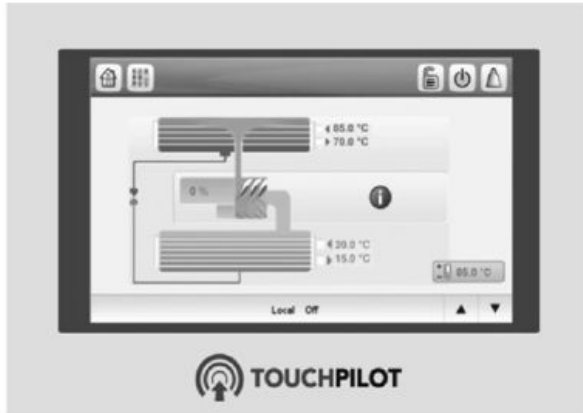

- New innovative smart control features:
  - An intuitive and user-friendly, coloured, 5" interface (7" optional)
  - Direct access to the unit's technical drawings and the main service documents
  - Screen-shots with concise and clear information in local languages
  - Complete menu, customised for different users (end user, service personnel and Carrier-factory technicians)
  - Easy access to the controller box with inclined touch screen mounting to ensure legibility under any lighting conditions
  - Safe operation and unit setting: password protection ensures that unauthorised people cannot modify any advanced parameters
  - Simple and "smart" intelligence uses data collection from the constant monitoring of all machine parameters to optimise unit operation.
- Energy management:
  - Internal time schedule controls heat pump on/off times and operation at a second set-point
  - The DCT (Data Collection Tool) records the alarms history to simplify and facilitate service operations.

#### Remote Management (Standard)

- Units with Touch Pilot control can be easily accessed from the internet, using a PC with an Ethernet connection. This makes remote control quick and easy and offers significant advantages for service operations.
- The 61XWHZE also communicates with other building management systems via optional communication gateways.
- The 61XWHZE is equipped with an RS485 serial port that offers multiple remote control, monitoring and diagnostic possibilities. Carrier offers a vast choice of control products, specially designed to control, manage and supervise the operation of an air conditioning system. Please consult your Carrier representative for more information.
- The following commands/visualisations are possible from remote connection:
  - Condenser pumps control: a digital input allows verification of condenser water flow (the flow switch must be supplied by the installer)
  - Start/stop of the machine

- Dual set-point management: through a dedicated contact it is possible to activate a second set-point (example: unoccupied mode)
- Demand limit setting: to limit the maximum heat pump capacity to a predefined value
- Operation visualization: indication if the unit is operating or if it's in stand-by no heating load
- alarm visualization.

#### Remote management (EMM option)

- The Energy Management Module offers extended remote control possibilities:
  - Room temperature: permits set-point reset based on the building indoor air temperature (with Carrier thermostat)
  - Set point reset: ensures reset of the heating set-point based on a 4-20 mA signal
  - Demand limit: permits limitation of the maximum heat pump power or current based on a 4-20 mA signal
  - Demand limit 1 and 2: closing of these contacts limits the maximum heat pump power or current to two predefined values
  - User safety: this contact can be used for any customer safety loop; opening of the contact generates a specific alarm
  - Time schedule override: closing of this contact cancels the time schedule effects
  - Out of service: this signal indicates that the heat pump is completely out of service
  - Heat pump capacity: this analogue output (0-10 V) gives an immediate indication of the heat pump capacity
  - Alert indication: this volt-free contact indicates the necessity to carry out a maintenance operation or the presence of a minor fault.

#### 06T screw compressor

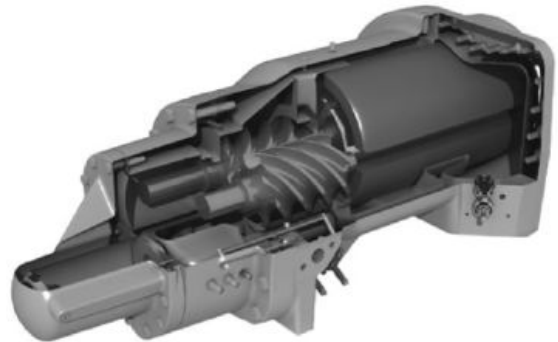

The Carrier 06T screw compressor designed for operation with HFO-1234ze refrigerant benefits from Carrier's long experience in the development of twin-rotor screw compressors. The compressor is equipped with bearings with oversized rollers, oil pressure lubricated for reliable and durable operation, even at maximum load.

A variable control valve controlled by the oil pressure permits infinitely variable cooling capacity. This system allows optimal adjustment of the compressor heating capacity and ensures exceptionally high stability of the hot water leaving temperature.

Among the other advantages: if a fault occurs e.g. if the condenser is fouled or at very high water temperature, the compressor does not switch off, but continues operation with a reduced capacity (unloaded mode).

The silencer in the discharge line considerably reduces discharge gas pulsations for much quieter operation.



## OPTIONS

Options	No.	Description	Advantages	Use for 61XWH range
Star / delta start	25A	Star / Delta start on each compressor	Reduced start-up current	3-5, 10
Master/slave operation	58	Unit equipped with supplementary water outlet temperature sensor kit to be field-installed allowing master/slave operation of two units connected in parallel	Optimised operation of two units connected in parrallele operation with operating time equalisation	3-17
Single power connection point	81	Unit power connection via one main supply connection	Quick and easy installation	10-17
No disconnect switch	82A	Unit without disconnect switch, but with short-circuit protection device	Permits an external electrical disconnect system for the unit (field-supplied), while ensuring unit short circuit protection	3-17
Evap. single pump power/control circuit	84	Unit equipped with an electrical power and control circuit for one pump evaporator side	Quick and easy installation: the control of fixed speed pumps is embedded in the unit control	3-10 Not available on 61XWHHZE
Evap. dual pumps power/control circuit	84D	Unit equipped with an electrical power and control circuit for two pumps evaporator side	Quick and easy installation: the control of fixed speed pumps is embedded in the unit control	3-10 Not available on 61XWHHZE
Cond. single pump power/control circuit	84R	Unit equipped with an electrical power and control circuit for one pump condenser side	Quick and easy installation: the control of fixed speed pumps is embedded in the unit control	3-10 Not available on 61XWHHZE
Evaporator with one pass more	100A	Evaporator with one pass more on the water side	Optimise chiller operation when the chilled water circuit is designed with low waterflows (high delta T evaporator inlet/outlet)	3-17
Evaporator with one pass less	100C	Evaporator with one pass on the water side. Evaporator inlet and outlet on opposite sides.	Easy to install, depending on site. Reduced pressure drops	3-17
Condenser with one pass more	102A	Condenser with three passes on the water side. Condenser inlet and outlet on opposite sides.	Adapted to sites where larger temperature differences and smaller water flow rates are required	3-17
Condenser with one pass less	102C	Condenser with one pass on the water side. Condenser inlet and outlet on opposite sides.	Easy to install, depending on site. Reduced pressure drops	3-17
21 bar evaporator	104	Reinforced evaporator for extension of the maximum water-side service pressure to 21 bar (standard 10 bar)	Covers applications with a high water column evaporator side (typically high buildings)	3-17
21 bar condenser	104A	Reinforced condenser for extension of the maximum water-side service pressure to 21 bar (standard 10 bar)	Covers applications with a high water column condenser side (typically high buildings)	3-17
Reversed evaporator water connections	107	Evaporator with reversed water inlet/outlet	Easy installation on sites with specific requirements	3-17
Reversed condenser water connections	107A	Condenser with reversed water inlet/outlet	Easy installation on sites with specific requirements	3-17
J-Bus gateway	148B	Two-directional communication board complying with JBus protocol	Connects the unit by communication bus to a building management system	3-17
Lon gateway	148D	Two-directional communication board complying with Lon Talk protocol	Connects the unit by communication bus to a building management system	3-17
Bacnet over IP	149	Two-directional high-speed communication using BACnet protocol over Ethernet network (IP)	Easy and high-speed connection by ethernet line to a building management system. Allows access to multiple unit parameters	3-17
Control for low cond. temperature	152	Output signal (0-10 V) to control the condenser water inlet valve	Simple installation: for applications with cold water at condenser inlet (ex. ground-source, groundwater-source, superficial water-source applications) the signal permits to control a 2 or 3-way valve to maintain condenser water temperature (and so condensing pressure) at acceptable values	3-17
Energy Management Module	156	EMM Control board with additional inputs/outputs. See Energy Management Module option chapter	Extended remote control capabilities (Set-point reset, ice storage end, demand limits, boiler on/off command...)	3-17
Compliance with Swiss regulations	197	Additional tests on the water heat exchangers: supply (additional of PED documents) supplementary certificates and test certifications	Conformance with Swiss regulations	3-17
Low noise level	257	Evaporator sound insulation	3 dB(A) quieter than standard unit	5-17



## OPTIONS

Options	No.	Description	Advantages	Use for 61XWH range
Welded evaporator connection kit	266	Victaulic piping connections with welded joints	Easy installation	3-17
Welded condenser water connection kit	267	Victaulic piping connections with welded joints	Easy installation	3-17
Flanged evaporator water connection kit	268	Victaulic piping connections with flanged joints	Easy installation	3-17
Flanged condenser water connection kit	269	Victaulic piping connections with flanged joints	Easy installation	3-17
Conformance with Moroccan regulations	327	Specific regulatory documentation	Conformance with Moroccan regulations	3-17

**PHYSICAL DATA**

61XWHLZE/61XWH-ZE/61XWHZE		Model	3	5	7	10	14	15	17
<b>61XWH-ZE</b> (Heating performances*)	Nominal capacity**	kW	300	484	727	967	1453	1468	1570
<b>Dimensions - 61XWHLZE/61XWH-ZE</b>									
Length		mm	2724	3059	3290	4730	4730	4790	4790
Width		mm	981	1041	1079	1125	1148	1399	1399
Height		mm	1594	1745	1968	2002	2070	2305	2305
<b>Dimensions - 61XWHZE</b>									
Length		mm	2724	3059	3290	4730	-	4790	-
Width		mm	981	1041	1079	1125	-	1417	-
Height		mm	1594	1745	1968	2002	-	2305	-
<b>Operating weight</b> <sup>(1)</sup>		kg	2054	2942	4147	7265	8031	9519	9519
<b>Compressors</b> Semi-hermetic 06T screw compressors, 50 r/s									
Circuit A		-	1	1	1	1	1	1	1
Circuit B		-	-	-	-	1	1	1	1
<b>Refrigerant - 61XWHLZE</b> <sup>(2)</sup> R1234ze									
Circuit A		kg	107	168	237	154	176	237	226
		teq CO <sub>2</sub>	0,7	1,2	1,7	1,1	1,2	1,7	1,6
Circuit B		kg	-	-	-	154	187	237	231
		teq CO <sub>2</sub>	-	-	-	1,1	1,3	1,7	1,6
<b>Refrigerant - 61XWH-ZE</b> <sup>(2)</sup> R1234ze									
Circuit A		kg	97	153	215	140	160	215	205
		teq CO <sub>2</sub>	0,7	1,1	1,5	1,0	1,1	1,5	1,4
Circuit B		kg	-	-	-	140	170	215	210
		teq CO <sub>2</sub>	-	-	-	1,0	1,2	1,5	1,5
<b>Refrigerant - 61XWHZE</b> <sup>(2)</sup> R1234ze									
Circuit A		kg	88	138	195	140	-	195	-
		teq CO <sub>2</sub>	0,6	1,0	1,4	1,0	-	1,4	-
Circuit B		kg	-	-	-	140	-	195	-
		teq CO <sub>2</sub>	-	-	-	1,0	-	1,4	-
<b>Oil - standard unit</b> HATCOL4496									
Circuit A		l	20	20	25	20	25	25	25
Circuit B		l	-	-	-	20	25	25	25
<b>Capacity control</b> Touch Pilot, electronic expansion valves (EXV)									
Minimum capacity		%	50	50	50	25	25	25	25
<b>Evaporator</b> Multi-pipe flooded type									
Water volume		l	61	101	154	293	321	354	354
Water connections (Victaulic)		in	5	6	8	8	8	8	8
Drain and vent connections (NPT)		in	3/8	3/8	3/8	3/8	3/8	3/8	3/8
Max. water-side operating pressure		kPa	1000	1000	1000	1000	1000	1000	1000
<b>Condenser</b> Multi-pipe flooded type									
Water volume		l	55	103	148	316	340	426	426
Water connections (Victaulic)		in	5	6	8	8	8	8	8
Drain and vent connections (NPT)		in	3/8	3/8	3/8	3/8	3/8	3/8	3/8
Max. water-side operating pressure		kPa	1000	1000	1000	1000	1000	1000	1000

\* In accordance with standard EN14511-3:2022.

\*\* Heating mode conditions: Evaporator entering/leaving water temperature 20°C/15°C, condenser entering/leaving water temperature 70°C/75°C, evaporator and condenser fouling factor 0 m<sup>2</sup>. k/W

(1) Weight shown is guideline only. Please refer to the unit nameplate

(2) Refrigerant charge shown is guideline only. Charge may differ according to options. Please refer to the unit nameplate

## ELECTRICAL DATA

61XWHLZE / 61XWH-ZE	Model	3	5	7	10	14	15	17
<b>Power circuit</b>								
Nom. power supply	V-ph-Hz	400-3-50						
Voltage range	V	360-440						
<b>Control circuit</b>								
24 V via the built-in transformer								
<b>Maximum start-up current<sup>(1)</sup> - Standard unit</b>								
Circuit A	A	1210	1828	1919	1828	1919	1919	1919
Circuit B	A	-	-	-	1828	1919	1919	1919
Option 81	A	-	-	-	2158	2425	2425	2407
<b>Maximum start-up current - Star/delta start option<sup>(2)</sup></b>								
Circuit A	A	388	587	-	587	-	-	-
Circuit B	A	-	-	-	587	-	-	-
Transient (< 150ms)	A	1210	1828	-	1828	-	-	-
Option 81	A	-	-	-	943	-	-	-
Transient (< 150ms)	A	-	-	-	2158	-	-	-
<b>Cosine phi</b>								
Nominal		0,70	0,80	0,81	0,80	0,81	0,81	0,83
Maximum <sup>(2)</sup>		0,89	0,89	0,89	0,89	0,89	0,89	0,89
Total harmonic distortion <sup>(2)</sup>	%	Closed to 0% (negligible)						
<b>Maximum power input<sup>(3)</sup></b>								
Circuit A	kW	137	203	312	203	312	312	301
Circuit B	kW	-	-	-	203	312	312	301
Option 81	kW	-	-	-	406	624	624	602
<b>Maximum current drawn (Un)<sup>(3)</sup></b>								
Circuit A	A	222	330	506	330	506	506	488
Circuit B	A	-	-	-	330	506	506	488
Option 81	A	-	-	-	660	1012	1012	976
<b>Maximum current drawn (Un -10%)<sup>(2)</sup></b>								
Circuit A	A	240	356	546	356	546	546	527
Circuit B	A	-	-	-	356	546	546	527
Option 81	A	-	-	-	712	1092	1092	1054

(1) Instantaneous start-up current for star connection (maximum operating current of the smallest compressor(s) + locked rotor current or reduced start-up current of the largest compressor). Values obtained at operation with maximum unit power input.

(2) Values obtained at operation with maximum unit power input.

(3) Values obtained at operation with maximum unit power input. Values given on the unit name plate.

61XWHHZE	Model	3	5	7	10	14	15	17
<b>Maximum start-up current<sup>(1)</sup> - Standard unit</b>								
Circuit A	A	1210	1828	1919	1828	-	1919	-
Circuit B	A	-	-	-	1828	-	1919	-
Option 81	A	-	-	-	2188	-	-	-
<b>Maximum start-up current - Star/delta start option<sup>(2)</sup></b>								
Circuit A	A	388	587	-	587	-	-	-
Circuit B	A	-	-	-	587	-	-	-
Transient (< 150ms)	A	1210	1828	-	1828	-	-	-
Option 81	A	-	-	-	947	-	-	-
Transient (< 150ms)	A	-	-	-	2188	-	-	-
<b>Maximum power input<sup>(4)</sup></b>								
Circuit A		148	222	334	222	-	334	-
Circuit B		-	-	-	222	-	334	-
Option 81	%	-	-	-	444	-	-	-
<b>Maximum current drawn (Un)<sup>(4)</sup></b>								
Circuit A	kW	241	360	543	360	-	543	-
Circuit B	kW	-	-	-	360	-	543	-
Option 81	kW	-	-	-	720	-	-	-
<b>Maximum current drawn (Un -10%)<sup>(3)</sup></b>								
Circuit A	A	260	389	586	389	-	586	-
Circuit B	A	-	-	-	389	-	586	-
Option 81	A	-	-	-	778	-	-	-

(1) Instantaneous start-up current for delta connection (maximum operating current of the smallest compressor(s) + locked rotor current or reduced start-up current of the largest compressor).

(2) Both Max start-up current and transient peak to be considered for installation

(3) Values obtained at operation with maximum unit power input.

(4) Values obtained at operation with maximum unit power input. Values given on the unit name plate.

## DIMENSIONS/CLEARANCES

### 61XWHLZE/61XWH-ZE/61XWHHZE 03-05-07

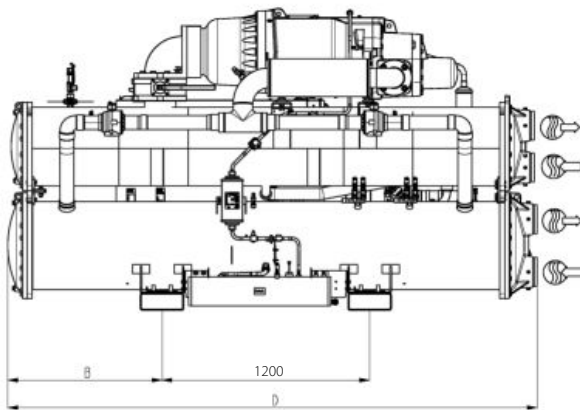
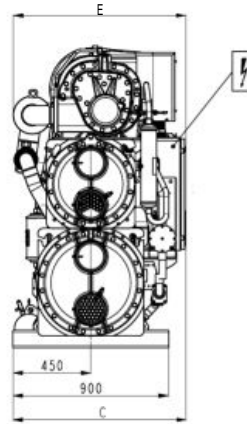
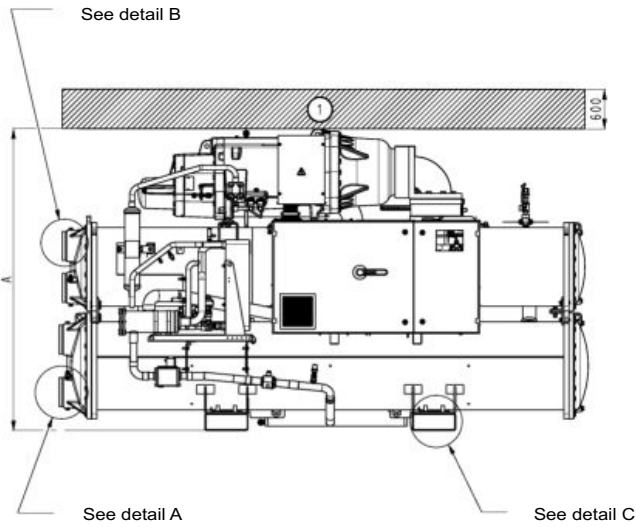

61XWHLZE/61XWH-ZE/61XWHHZE								
	A	B	C	D	E	F	G	H
Model	Dimensions in mm							
3	1594	723	981	2724	982	141,3	141,3	2600
5	1745	891	1041	3059	1039	168,3	168,3	2900
7	1968	1007	1079	3290	1170	219,1	219,1	3100

#### Legend

All dimensions are given in mm

- Services clearances required
- Space required to remove cooler tubes
- Inlet water
- Outlet water
- Electrical supply entry

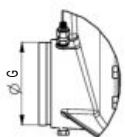
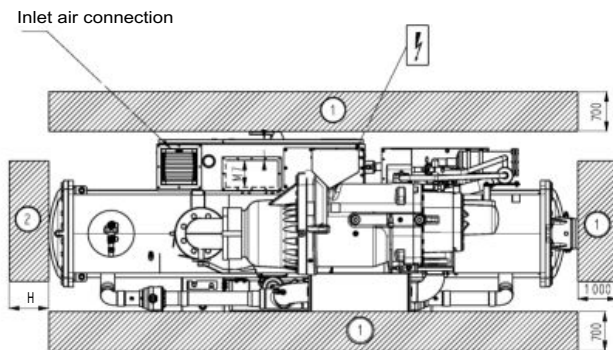

Detail A

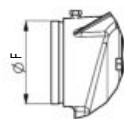

Detail B



Detail C

#### NOTES:

- Drawings are not contractually binding. Before designing an installation, consult the certified dimensional drawings supplied with the unit or available on request.
- For the positioning of the fixing points, weight distribution and centre of gravity coordinates please refer to the dimensional drawings.

**DIMENSIONS/CLEARANCES**

**61XWHLZE/61XWH-ZE 10-14-15-17; 61XWHHZE 10-15**

PRESENTATION

COOLING

HEATING

AIR TREATMENT

CONTROLS

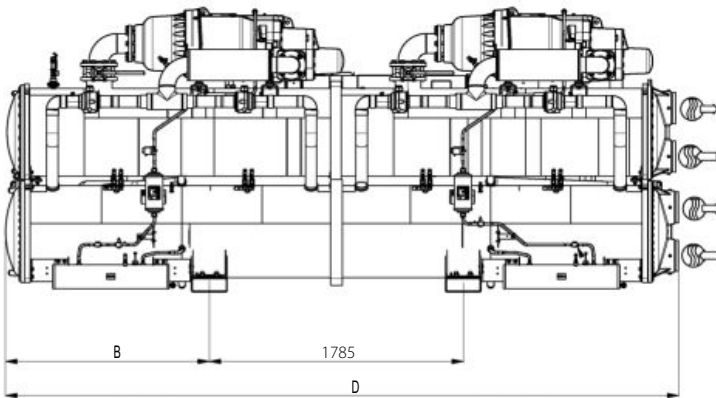
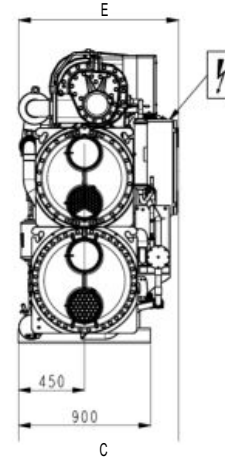
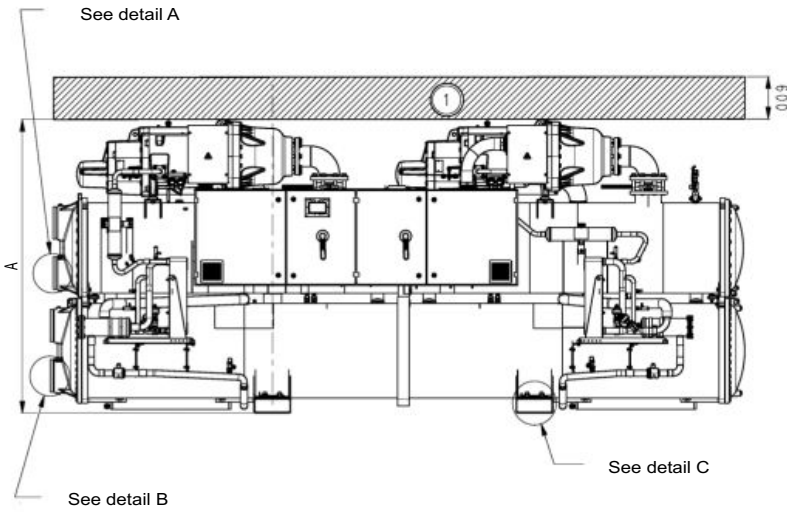

61XWHLZE/61XWH-ZE								
	A	B	C	D	E	F	G	H
<b>Model</b>	<b>Dimensions in mm</b>							
<b>10</b>	2002	1432	1124	4730	1124	219,1	219,1	4500
<b>14</b>	2070	1432	1148	4730	1237	219,1	219,1	4500
<b>15</b>	2305	1458	1399	4790	1264	219,1	219,1	4500
<b>17</b>	2305	1458	1399	4790	1264	219,1	219,1	4500

61XWHHZE								
	A	B	C	D	E	F	G	H
<b>Model</b>	<b>Dimensions in mm</b>							
<b>10</b>	2002	1432	1124	4730	1124	219,1	219,1	4500
<b>15</b>	2305	1458	1417	4790	1282	219,1	219,1	4500

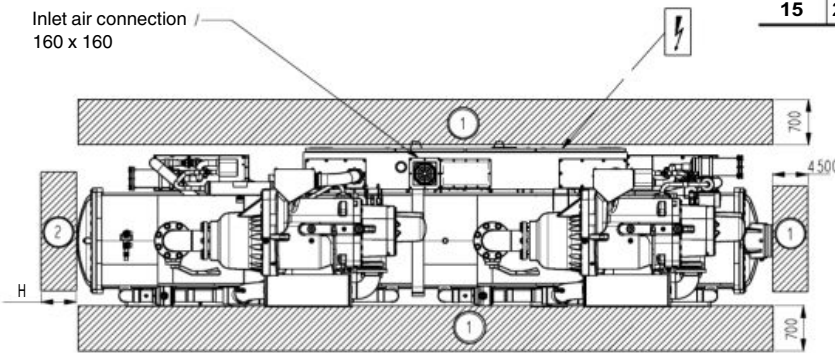

**Legend**

All dimensions are given in mm

- Services clearances required
- Space required to remove cooler tubes
- Inlet water
- Outlet water
- Electrical supply entry



Detail A



Detail B

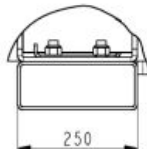

Detail C

**NOTES:**

- Drawings are not contractually binding. Before designing an installation, consult the certified dimensional drawings supplied with the unit or available on request.
- For the positioning of the fixing points, weight distribution and centre of gravity coordinates please refer to the dimensional drawings.







PRESENTATION

COOLING

HEATING

AIR TREATMENT

CONTROLS

# Air treatment

# 781

Type	Range	Cooling capacity, kW	Heating capacity, kW	Air flow m <sup>3</sup> /h	Page		
<b>Hybrid Terminal</b>	NEW 36XH	Up to 4.7	Up to 8.79	-	783		
<b>Air heaters</b>	42AM	-	-	1400-11000	815		
<b>Chilled-water terminal units</b>							
Cassette	Cabinet	Concealed/Ducted					
	x		42SI	0.55-2.9	0.57-2.5	-	835
	x		42WM	1.2-3.8	1.3-4.3	-	845
		x	42EP	0.4-4.2	0.5-5	-	855
	x		42NC/ND	0.7-8.7	1-9.15	-	877
x			42KY	1-6	2-10	-	891
x			42GW	1.5-9.5	1.3-11.3	-	903
		x	42NL/NH	0.6-12	0.8-17	-	917
<b>Air handling units</b>							
	NEW	39CS	-	-	Up to 3200	969	
		39CQ	-	-	1000 - 6000	979	
		39HX	-	-	300 - 18000	985	
		39CP	-	-	1000 - 30000	993	
		39CZ	-	-	25000 - 60000	1005	
		39HQ	-	-	5000 - 130000	1019	
<b>Close control units</b>							
		50CJ	5-47	4-41	1300 - 12000	1023	
		50CO	40-100	18-73	10000 - 27000	1033	
<b>Rooftop units</b>							
	NEW	50FF-FC 020-093	22-90	22-90		1039	
		50FF-FC 100-280	97-273	97-299	10800 - 54000	1065	
<b>Packaged units</b>							
	NEW	50NC	22-120	21-121	4000-22200	1089	
<b>ADVANCED HVAC CEILING SOLUTIONS</b>							
		Barrisol	-	-	-	1107	



**NEW**

## HYBRID TERMINAL UNIT



Three operating modes specially designed for the hotel industry

High energy efficiency

High indoor air quality

Thermal and acoustic comfort

Flexible installation

Three sizes available

# 36XH

Total cooling capacity up to 4.7 kW  
Total heating capacity up to 8.79 kW <sup>(1)</sup>

Specially designed for the hotel market, the Carrier 36XH hybrid terminal unit fulfils the building requirements in terms of energy sobriety, whilst offering the best level of thermal and acoustic comfort.

The 36XH combines the thermal benefits and responsiveness of a fan coil with the high ventilation capacities and energy efficiency of an active chilled beam.

Its innovative design, exclusive to Carrier, allows exceptional indoor air quality to be obtained thanks to the large fresh air supply capacity and optimised air diffusion.

Suitable for both new builds and renovations, the 36XH hybrid terminal unit offers great flexibility for the design of spaces.

(1) Based on the following conditions:

- Cooling mode / 2-tube:  
Water inlet/outlet temperature: 7/12 °C  
Room temperature: (dry bulb) = 27 °C  
and humidity = 47%  
Fresh air temperature = 14 °C  
With no discharge grille.

- Heating mode / 2-tube:  
Water inlet/outlet temperature: 65 °C/55 °C  
Room temperature: 20 °C  
Fresh air temperature = 20 °C  
With no discharge grille



## DESCRIPTION / APPLICATION

Exclusive to Carrier, the 36XH is an innovative solution which combines energy efficiency with a high level of comfort and indoor air quality:

The Carrier 36XH hybrid terminal unit has been specially designed for the hotel market and its specific needs.

Hotel managers have to reconcile two contradictory objectives: providing their occupants with optimum comfort, whilst managing the operating costs of an establishment with varying levels of occupation.

Its L-shaped design is designed for installation in a soffit.

The Carrier 36XH hybrid terminal unit comprises a chassis with a built-in hydraulic coil and fan motor assembly. The air supply is provided by an exclusive plenum patented by Carrier which combines the fresh air supply and the induction function.

Its unique design allows it to adapt its operation constantly, ensuring it always perfectly fulfils the requirements of the room in real time.

The Carrier 36XH hybrid terminal unit is able to reconcile these objectives **by ensuring energy sobriety, occupant comfort and rapid heating or cooling of rooms.**

**36XH integrates three operating modes specially designed for the needs of the hotel industry:**

- **ECO / QUIET mode:** induced air only mode, for unoccupied periods or during the night. Operation in active chilled beam mode is **very quiet and reduces energy usage.**
- **COMFORT / QUIET mode:** adaptive mode which combines induced air with exchanger operation. The exchanger provides **agile, responsive operation** to quickly reach the setpoints chosen by the occupant.
- **ACTIVE FAN / BOOST mode:** mode combining induced air, the exchanger and the fan to meet **sudden or intermittent needs**, such as a cold snap or hot spell or to perform a complete renewal of the air in the room, after the occupant has left, for example.

### COMPOSITION:

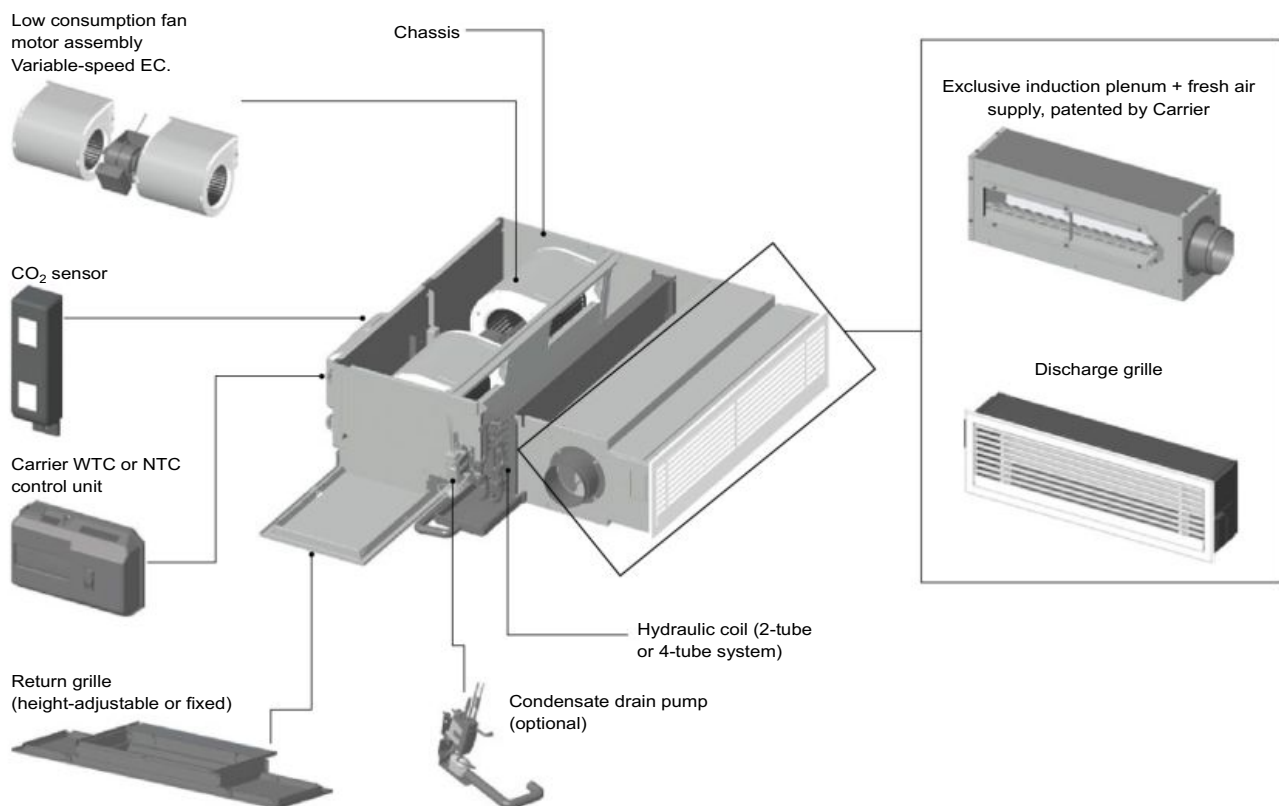

## CUSTOMER BENEFITS



### ENERGY EFFICIENCY AND EFFECTIVENESS

- The system can be run in different modes, including cold water temperature mode from 14 °C to reduce cold water production costs and to optimise sizing of the refrigeration units.
- Latent load management: the internal heat sources (lighting, bathroom steam, presence of the occupant, etc.) are taken into account.
- Very low pressure drops (limited impact on the air handling unit).
- Fan: low consumption EC motor.
- Inputs from free cooling when operating in air conditioning mode.



### COMFORT

- Highly reactive to changes in load: rapid restart to reach the setpoints set by the occupant very quickly.
- Very quiet operation without draughts.
- Three operating modes for constant adaptation to requirements and usages: ECO / QUIET - COMFORT / QUIET – ACTIVE FAN /BOOST



### INDOOR AIR QUALITY

- The 36XH and its induction-based operation provides a large supply of fresh air and renewal of large volumes of air, rule number 1 for indoor air quality.
- The fresh air introduced into the room is preconditioned and filtered by the air handling unit to ensure it is at the right temperature and the right degree of humidity, and free of any fine particles and VOCs.
- The ventilation is regulated based on the demand and this, combined with a higher indoor air renewal rate, improves the well-being of the occupants.



### EASY INSTALLATION

- Low height profile (283 mm with fixed grille - 350 mm max with height-adjustable grille) to facilitate installation in a suspended ceiling and ensure maximum space savings.
- Two possible combinations for the return air:
  - Large return grille (fixed grille).
  - Height-adjustable grille (standard dimensions).

## OPERATION

---

Three operating modes adapted to the occupancy cycles of the rooms:

### ECO / QUIET MODE

Fresh air supply and induction

This mode combines comfort with energy sobriety.

- The cooling and heating requirements are fulfilled on the primary air by the air handling unit.
- Operation is very quiet and energy efficient.
- The large volumes of fresh air provided by the 36XH hybrid terminal unit ensure very high indoor air quality and maximise the potential of the free cooling enabled by the AHU.
- A CO<sub>2</sub> sensor can be added to regulate the provision of fresh air based on the occupancy of the room and its level of CO<sub>2</sub> saturation.

This mode can be configured as the default or to run at a set time (during night hours, for example)

### COMFORT / QUIET MODE

Induced fresh air

+ hydraulic coil activated.

Operation in active chilled beam mode: adaptive mode which combines induced air with the action of the coil. The exchanger provides agile, responsive operation to quickly reach the setpoints chosen by the occupant

Main operating mode for the hybrid terminal unit, covering 80% of requirements (according to Carrier's in-house study conducted on an installation in Paris, France).

### ACTIVE FAN / BOOST MODE

Induced fresh air

+ water exchanger activated

+ fan active.

ACTIVE FAN / BOOST mode corresponds to operation in fan coil mode and is used to meet sudden or intermittent needs, such as a cold snap or hot spell or to perform a complete renewal of the air in the room, after the occupant has left, for example.

The 36XH combines the effects of fresh air induction and the water coil to ensure the cooling or heating requirements are met.

The high responsiveness of the system allows any changes to the setpoint to be compensated for quickly.

The fan allows for a quick, efficient response to demand or to quickly perform a complete renewal of the volume of air in the room, after the occupant has checked out, for example.

## CODES

**Table of codes**

Feature name	Digit	Value	Description	Feature
<b>Range</b>	1-2	36		
	3-4	XH		
<b>Chassis size</b>	5	0	Chassis size 0	
		2	Chassis size 2	
		3	Chassis size 3	
<b>Coil</b>	6	2	2-row coil (2-tube)	Digit 5 = 0 only
		3	3-row coil (2-tube)	Digit 5 = 2 & 3 only
		4	4-row coil (4-tube)	Digit 5 = 0, 2 & 3 only
<b>Fan type</b>	7	9	Low consumption EC motor	
<b>Connection and coil type</b>	8	F	2-tube coil, left-hand	Utilities provided, top view
		G	2-tube coil, right-hand	
		C	4-tube coil, left-hand	
		D	4-tube coil, right-hand	
<b>Control</b>	9	K	NTC	Not compatible with Digit 19 = E
		L	NTC + CO <sub>2</sub> sensor (IAQ)	Digit 19 = E compulsory
		M	WTC Bacnet	Not compatible with Digit 19 = E
		N	WTC Bacnet + CO <sub>2</sub> sensor (IAQ)	Digit 19 = E compulsory
<b>Valve body</b>	10	G	Standard two-way valve	Not compatible with Digit 12 = E
		H	Standard four-way valve	40 mm centre distance
		L	Self-balancing two-way valve without pressure tappings	Not compatible with Digit 12 = E
		T	Self-balancing two-way valve without pressure tappings	Not compatible with Digit 12 = E
<b>Valve actuator</b>	11	A	On/Off 230 V thermal actuator	
		C	Floating 3-point 230 V actuator	
<b>Sensor</b>	12	D	Return air sensor and supply air sensor	
		E	Return air sensor and supply air sensor + changeover sensor	Only compatible with digit 10 = H and Digit 8 = F & G
<b>Filter</b>	13	-	G3 filter integrated into the return grille	Standard – Return grille available as a compulsory accessory
<b>Fresh air inlet</b>	14	O	Opposite side to the hydraulic connections	
		S	Same side as the hydraulic connections	Standard
<b>Connection sleeve</b>	15	-	Without rectangular sleeve on the supply air	Discharge grille assembly to be fitted directly on the unit (assembly without duct)
		M	With rectangular sleeve on the supply air	Duct to be provided by the customer
<b>Hydraulic connections from the rear</b>	16	-	Without	Standard
		F	With flexible connections with male swivel nuts	Supplied separately. Length 600 mm. Insulated on the cooling coil.
<b>Electrical protection</b>	17	F	Fuse holder	Factory-fitted
		C	Circuit breaker	
<b>Condensate drain pump</b>	18	-	Without	
		P	Factory-fitted	
<b>Fresh air spigot</b>	19	A	Smooth spigot, Ø125 mm (factory-fitted)	Standard - Only with Digit 9 = K & M
		B	Spigot with self-adjusting module from 15 to 50 m <sup>3</sup> /h Ø125 mm (factory-fitted)	Only with Digit 9 = K & M
		C	Spigot with self-adjusting module from 50 to 100 m <sup>3</sup> /h Ø125 mm (factory-fitted)	Only with Digit 9 = K & M
		D	Spigot with self-adjusting module from 100 to 180 m <sup>3</sup> /h Ø125 mm (factory-fitted)	Only with Digit 9 = K & M
		E	¼ turn adapter with motorised fresh air valve, Ø125 mm (supplied separately)	Only with Digit 9 = L & N

## MAIN MODULES AND COMPONENTS

### Chassis

The chassis is made of galvanised sheet steel with nickel-plated zinc-coated steel fastenings and a full high-efficiency internal lining made from 10 mm of polyester textile fibre for optimised thermal and sound insulation of the unit.

To comply with the various local regulations (fire rating), the hybrid terminal unit is available with Claas M1 insulation (in accordance with the standard NF P 92-507).

It can also be equipped with elastomer anti-vibration mounts (optional).

### Return air grille with integrated filter door

The microperforated return grille and frame assembly ① made from galvanized steel painted RAL9003 (white), with filter housing. Return grille fitted on hinges with clip fastening system ②.

A safety stop catch limits the opening of the grille and a tool must be used to open the grille completely to prevent any risk of injury.

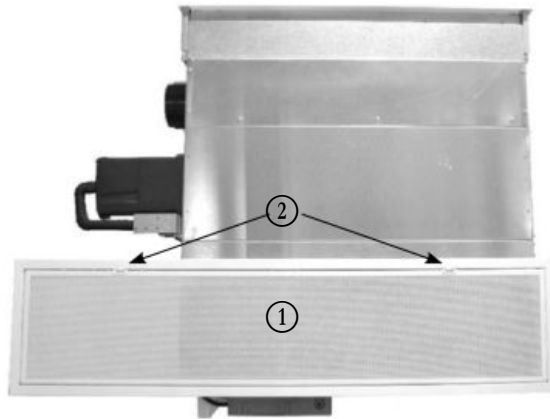

Several sizes available, for a choice between discreet design and accessibility to the external components of the unit (valve, condensate pump, electrics box).

The return air grille folds up vertically and can be adjusted from 0 mm to 40 mm (in increments of 5 mm).

The return air grille can be adjusted horizontally (up to 3 positions depending on the models) in relation to the unit chassis.

Wide opening allowing access to the fan motor assembly and its removal.



Grille supplied in a separate package, to be fitted on the unit on-site.



## MAIN MODULES AND COMPONENTS

Grille selection table: (L grilles available from the second quarter of 2023)

	T0	T2	T3
<b>S return grille</b> (700x295) height-adjustable	•	•	
<b>S return grille</b> (1195x295) height-adjustable <sup>(1)</sup>		•	•
<b>L return grille</b> (695x495) height-adjustable	•		
<b>L return grille</b> (695x495) fixed	•		
<b>L return grille</b> (860x495) height-adjustable		•	
<b>L return grille</b> (860x495) fixed		•	
<b>L return grille</b> (1060x495) height-adjustable			•
<b>L return grille</b> (1060x495) fixed			•

- Compatible
- Not compatible

(1) The S grille (1195x295) is the preferred option for installations in suspended ceilings with T-shaped aluminium profiles and tiles measuring 600 x 600 mm.

### Return grille adjustment

- Vertical adjustment from 0 to 40 mm (in increments of 5 mm):
  - Open the grille fully using the 2 clips.
  - Remove the grille and its filter.
  - Remove the 4 screws then adjust the vertical opening with the adjustment holes provided. Refit the screws.
  - Completely seal all the remaining holes from the inside with aluminium tape.

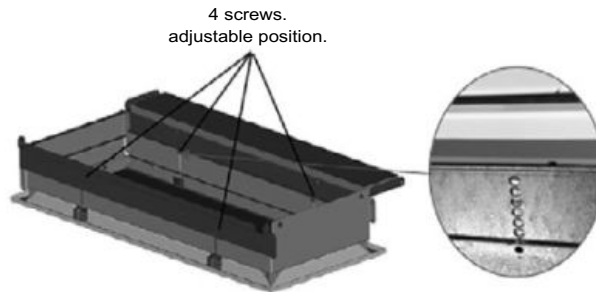

## MAIN MODULES AND COMPONENTS

■ Horizontal adjustment:

The grille can be centred on the unit's return or offset to one side, depending on the requirements of the installation.

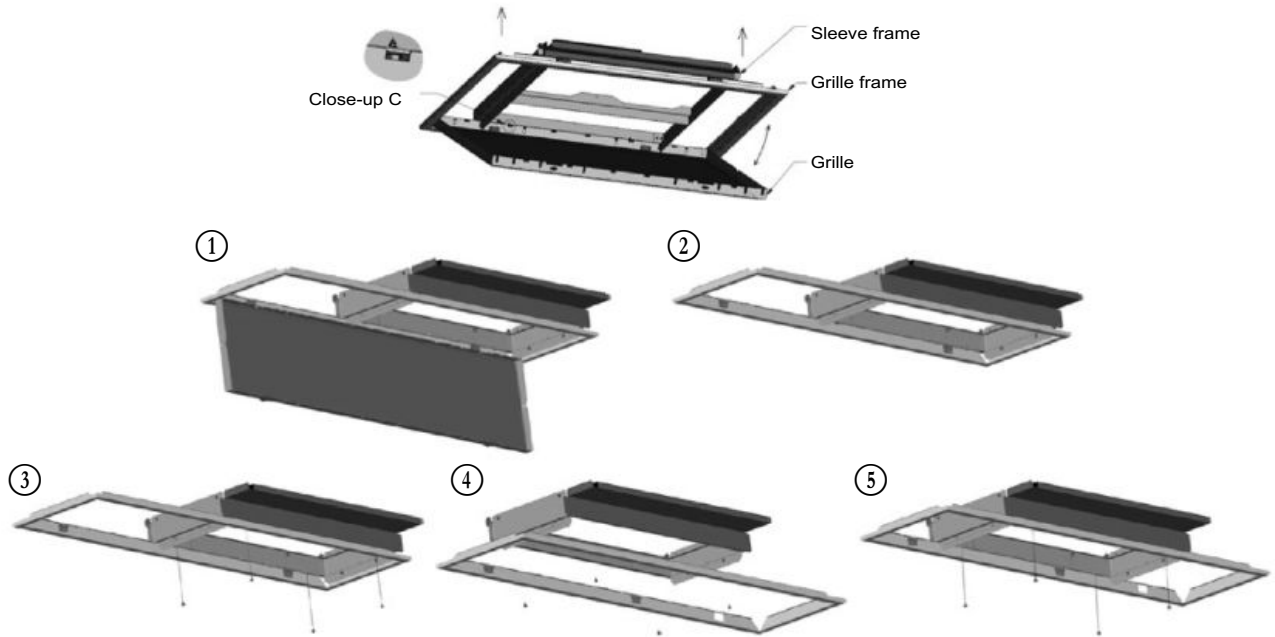

- ① Open the filter door grille using the 2 clips.
- ② Remove the grille and its filter completely.
- ③ Unscrew the 4 interior screws which hold the frame on the sleeve.
- ④ Move the support panel.
- ⑤ Refit the 4 screws and the filter door grille.

	Available positions					
	T0		T2		T3	
<b>S return grille (700x295)</b>						
<b>S return grille (1195x295)</b>						
<b>L return grille (695x495)<sup>(1)</sup></b>						
<b>L return grille (860x495)<sup>(1)</sup></b>						
<b>L return grille (1060x495)<sup>(1)</sup></b>						

(1) The L return grilles are available from the second half of 2023.

### Filter

- The Carrier 36XH hybrid terminal unit is equipped with a coarse ISO filter: ePM10 < 50 %, non-regenerative, as per ISO standard 16890, or G3 as per EN 779, sewn onto a metal wire frame.

M1 fire rating for the medium.

The filter is easy to access, directly from the return grille on the unit.

## MAIN MODULES AND COMPONENTS

### Supply plenum and fresh air supply

Patented and exclusive to Carrier:

The Carrier 36XH hybrid terminal unit has an insulated supply plenum ① integrating air discharge nozzles ② which generate an induction effect via the intake of fresh air to allow for quiet, economic operation whilst limiting the use of the fan motor assembly.

A lateral sleeve measuring  $\varnothing 125$  mm ③ is fitted as standard on the plenum to allow for the intake of fresh air. This sleeve can be installed on the left or right-hand side of the plenum (to be stated when ordering), and be equipped (as an option) with a constant flow controller, or it can be replaced with the quarter sleeve for the variable flow IAQ air valve. As an option, a supply air sleeve can be added to allow a duct to be connected (duct not provided).

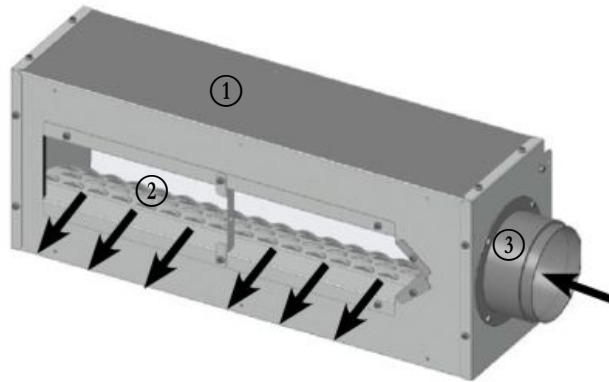

### Unit mounting

The Carrier 36XH hybrid terminal unit can be fitted in a suspended ceiling using 4 threaded rods with resilient mounts from Carrier (optional): minimum diameter 6 mm and maximum 8 mm.

Without resilient mounts: diameter of 8 mm to 10 mm with a nut/washer assembly positioned on either side of the mounting bracket.

## SPECIFICATIONS FOR THE OPTIONS

### Diffusion kit assembly

The diffusion kit acts as a natural extension of the supply plenum. It is formed of a rectangular connection plenum <sup>①</sup> made from galvanised steel, insulated with 10 mm of polyester textile fibre, a finishing frame <sup>②</sup>, and a diffusion grille <sup>③</sup>. It can be embedded in a partition which is between 7 mm and 77 mm thick.

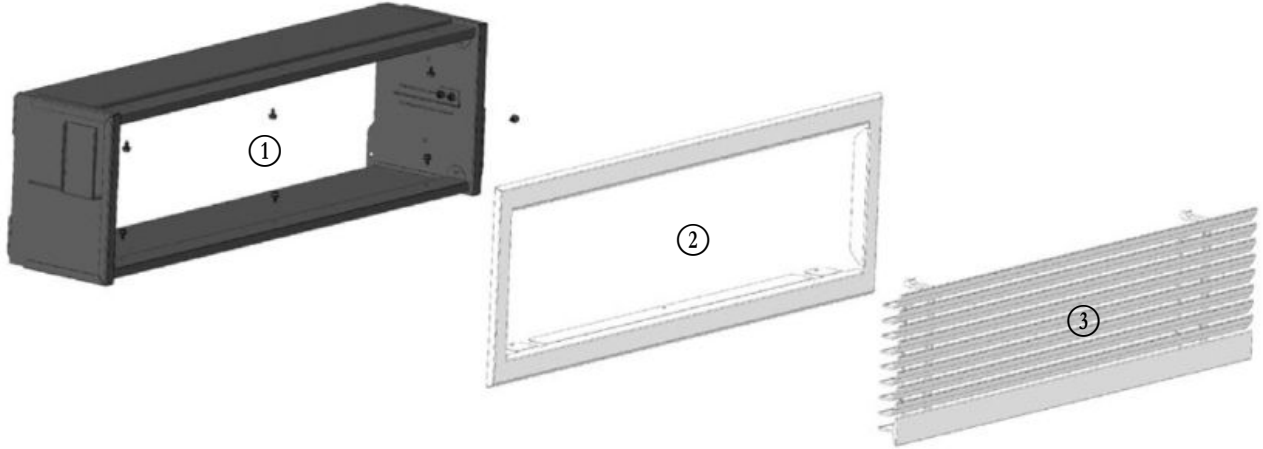

The finishing frame <sup>②</sup> and the diffusion grille <sup>③</sup> are made from galvanised steel painted RAL9003 with upward-facing fins to optimise the Coanda effect and thereby maximise the comfort of the occupant and the diffusion performances. Its streamlined design allows it to be discreetly integrated into the premises.



The diffusion kit can be fitted (on-site) directly on the Carrier 36XH hybrid terminal unit (fig. A) or it can be offset from the unit and connected via a rigid rectangular insulated duct (fig. B) (not provided). The duct must not be longer than 1500 mm.

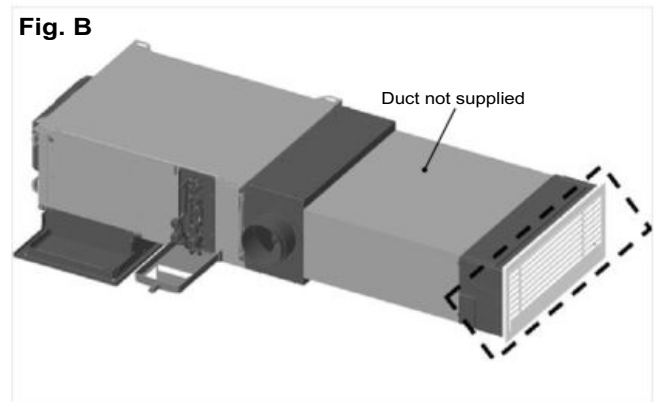
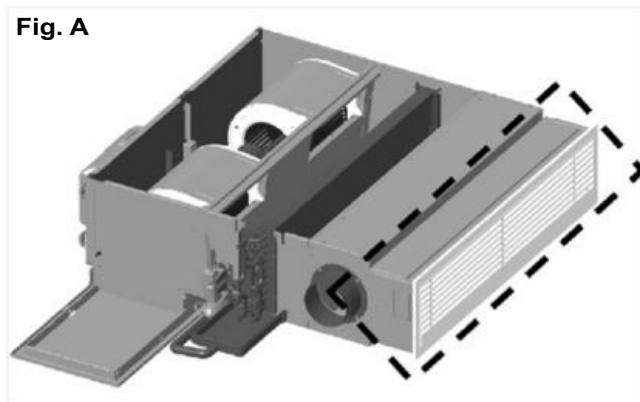

### Sleeve for connection to the supply air

To enable a duct to be connected to the supply air, the Carrier 36XH hybrid terminal unit must be equipped with a rectangular supply air sleeve made from smooth sheet metal, available as a factory-fitted option.

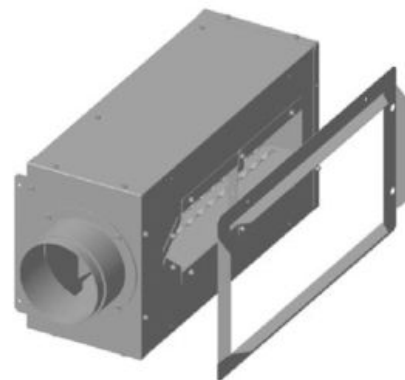

## SPECIFICATIONS FOR THE OPTIONS

### Constant volume fresh air controller

The Carrier 36XH hybrid terminal unit can be equipped as an option with a constant fresh air flow controller which allows the intake of fresh air and the air change rate to be controlled.

Three models are available:

- Ø125 mm - Flow rates of 15 to 50 m<sup>3</sup>/h
- Ø125 mm - Flow rates of 50 to 100 m<sup>3</sup>/h
- Ø125 mm - Flow rates of 120 to 180 m<sup>3</sup>/h

The fresh air controller can be adjusted on-site using the adjustment screw.

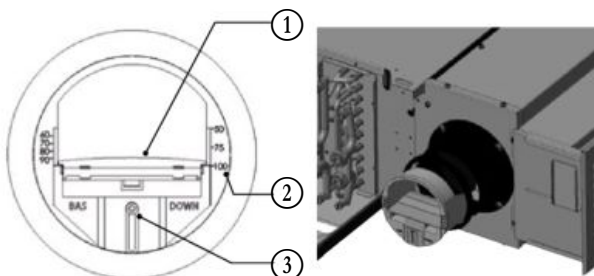

**NOTE: To ensure the flow rate controllers operate correctly, a differential pressure of between 60 and 210 Pa is required.**

- ① Air damper
- ② Fresh air damper position setting (in m<sup>3</sup>/h)
- ③ Air flow adjustment screw.

### Variable volume fresh air controller (IAQ valve)

The Carrier 36XH hybrid terminal unit can accept (as an option) an IAQ valve combining a differential pressure measurement component and a fresh air flow controller with a variable valve (from 0 to 200 m<sup>3</sup>/h), driven by a progressive 24 VAC actuator with a 0-10 VDC input signal.

Connected and supplied by the Carrier NTC or WTC digital control, the IAQ valve can regulate the intake of fresh air in two ways:

- Either using a fixed rate set by the installer that can be reconfigured as required,
- Or according to the CO<sub>2</sub> concentration. In this case, it is controlled by the CO<sub>2</sub> sensor which is connected via the Carrier digital control.



**NOTE: The IAQ valve is supplied separately. Its remote installation on the fresh air network is recommended to limit nuisance noise in the room.**

To be able to read the differential pressure correctly, the connection shall be made with a minimum straight length of 180 mm, whilst avoiding any disruption to the air flow upstream of the measurement component. The upstream pressure in the duct network must be 180 Pa or greater.



## SPECIFICATIONS FOR THE OPTIONS

### Sensors

#### CO<sub>2</sub> sensor

As an option with the Carrier NTC or WTC controls, and combined with the variable flow fresh air flow controller, a CO<sub>2</sub> sensor placed at the unit's air return ensures the correct CO<sub>2</sub> level in the rooms to be conditioned. A 0-10 VDC analogue output is used to precisely adjust the fresh air flow over a measurement range from 0 to 2000 ppm.



#### Air temperature sensors

Two factory-fitted air temperature sensors are available as an option for NTC and WTC controllers. They measure the temperature at the supply and return side.

#### Water temperature sensor

A water temperature sensor can be provided as an option for NTC and WTC controllers.

- For a 2-tube coil: the sensor is installed on the hot/cold water coil inlet (for the changeover function).
- For a 4-tube coil: the sensor is installed on the hot water coil inlet (for the cold-draught function that prevents the operation of the unit when the hot water network is off).

## VALVES AND ACTUATORS

**NOTE: The electrothermic valve + actuator assemblies are normally closed when there is no voltage.**

#### Valve actuators

The valve actuators are used to actuate the water flow control valves for the hydraulic coils. They are fitted directly on the two- and four-way valve bodies (three-way with bypass) or self-balancing two-way valves. Their specifications are adapted to the NTC and WTC controls:

- Electrothermic actuator (on/off)
  - Supply voltage 230 V~ +/-10% – 50/60 Hz
  - First Open function (valve open before the initial power up allowing the installation to be filled and drained)
  - Re-Open function (allows the First Open function to be re-engaged)
  - Position indicator
  - Cable length: 2 m (2 x 0.75 mm<sup>2</sup>)
  - Index of Protection: IP54, allowing for assembly in all the positions.
  - Quiet, and maintenance-free
  - Assembly on the valve using an M30x1.5 nut
  - Operating limit: room temperature 0 to 50 °C
  - Opening time 0-100% (travel of 3 mm): ~140 sec.
  - Power input during operation: 1.8 W – 1.8 VA



## SPECIFICATIONS FOR THE OPTIONS

- Floating 3-point actuator
  - Supply voltage 230 V~ +/-10% - 50/60 Hz
  - Stepper motor
  - Power up and activity checked using an LED
  - Cable length: 2 m (3 x 0.5 mm<sup>2</sup>)
  - Index of Protection: IP43 - Vertical or horizontal assembly
  - Quiet, and maintenance-free
  - Assembly on the valve using an M30x1.5 nut
  - Operating limit: room temperature 0 to 50 °C
  - Opening time 0-100% (travel of 3 mm): ~39 sec.
  - Power input during operation: 2 W – 6.5 VA



When combined with LEC motors and WTC or NTC controllers, floating 3-point 230 V actuators are recommended to increase energy savings and enhance comfort.

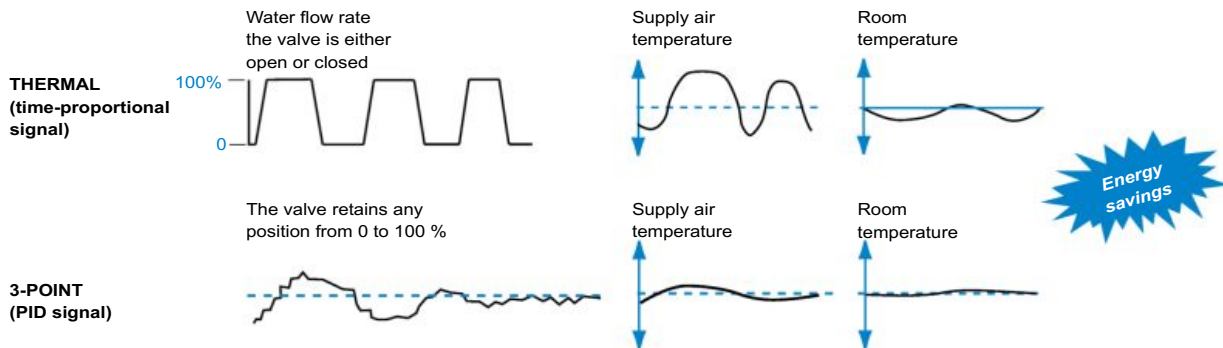

A 3-point motor actuator enables a valve to be actuated as close as possible to the control system requirements, by controlling its position between 0 and 100 % (water flow control). The terminal unit supply air temperature is more stable and the room temperature varies very little (variations cause discomfort).

This temperature stability not only ensures optimal comfort, it also allows energy savings to be made.

The 3-point actuator uses no electricity when the thermal balance is struck, unlike the thermal motor (return on investment on the energy savings made: 2 - 3 years).

### Standard two-way and four-way valve bodies (with built-in bypass)

- Valve body made from cast brass, nickel-plated brass rod with EPDM valve and packing box with O-ring.
- Linear operation.
- Compact, and maintenance-free
- Four-way valve with moulded linear bypass (not derated), 40 mm centre distance.
- Adjustment track normally closed when there is no voltage (actuator fitted)
- Flush-fitted male-male threaded couplings. (connection diameters, see § 8.2.3)
- Straight valve body with arrow indicating direction of flow embossed on valve body.
- Nominal pressure: 16 bar.

#### Kvs available by type of valve:

1/2" On/Off valve: Kvs 1.6

1/2" 3-point valve: Kvs 0.6

1/2" 3-point valve: Kvs 1



## SPECIFICATIONS FOR THE OPTIONS

### Types of couplings and connection diameters for the flexible connections (customer side)

Size	Application	Coil	Valve used	Coupling	Diameter
029	2-tube	Hot or cold water coil	Two-way valve	Flush-fitted threaded female swivel nut	G1/2" (inlet/outlet)
			Four-way valve		G1/2" (inlet/outlet)
			Two-way valve Self-balancing		G3/4" (inlet/outlet)
049	4-tube	Cold water coil	Two-way valve	Flush-fitted threaded female swivel nut	G1/2" (inlet/outlet)
			Four-way valve		G1/2" (inlet/outlet)
			Two-way valve Self-balancing		G3/4" (inlet/outlet)
	Hot water coil	Two-way valve	G1/2" (inlet/outlet)		
		Four-way valve	G1/2" (inlet/outlet)		
		Two-way valve Self-balancing	G1/2" (inlet/outlet)		
239	2-tube	Hot or cold water coil	Two-way valve	Flush-fitted threaded female swivel nut	G1/2" (inlet/outlet)
			Four-way valve		G1/2" (inlet/outlet)
			Two-way valve Self-balancing		G3/4" (inlet/outlet)
249	4-tube	Cold water coil	Two-way valve	Flush-fitted threaded female swivel nut	G1/2" (inlet/outlet)
			Four-way valve		G1/2" (inlet/outlet)
			Two-way valve Self-balancing		G3/4" (inlet/outlet)
	Hot water coil	Two-way valve	G1/2" (inlet/outlet)		
		Four-way valve	G1/2" (inlet/outlet)		
		Two-way valve Self-balancing	G3/4" (inlet/outlet)		
339	2-tube	Hot or cold water coil	Two-way valve	Flush-fitted threaded female swivel nut	G1/2" (inlet/outlet)
			Four-way valve		G1/2" (inlet/outlet)
			Two-way valve Self-balancing		G3/4" (inlet/outlet)
349	4-tube	Cold water coil	Two-way valve	Flush-fitted threaded female swivel nut	G1/2" (inlet/outlet)
			Four-way valve		G1/2" (inlet/outlet)
			Two-way valve Self-balancing		G3/4" (inlet/outlet)
	Hot water coil	Two-way valve	G1/2" (inlet/outlet)		
		Four-way valve	G1/2" (inlet/outlet)		
		Two-way valve Self-balancing	G3/4" (inlet/outlet)		

### Condensate drain pump

The condensate drain pump (optional) is a split unit pump with an oscillating piston designed to fit on the side of the unit drain pan outside of the unit. The oscillating piston fulfils the function of a check valve, preventing the return of condensates to the pan and shutting down the pump and blocking the siphoning effect of the pump unit and thereby prevent any risk of damage from running dry.

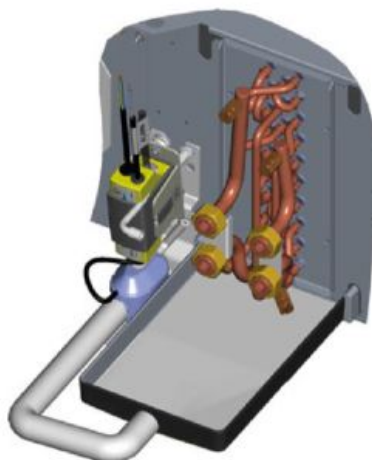

## SPECIFICATIONS FOR THE OPTIONS

Technical characteristics	
Maximum flow rate	10.4 l/hr
Max. discharge height	7 m (flow rate 4 l/h)
Max. pressure	10 m (flow rate 0 l/h)
Noise level at 1 m in compliance with EN ISO 3744 and 4871 (measurement made at the LNE, pump in water, outside of application)	10.2 dBA
Power supply	230 V +10%/-15% - 50/60 Hz -19 W
Electrical insulation class	Class 1
Detection levels	ON: 14.7 mm, OFF: 10.7 mm
	AL: 167 mm
Safety switch	NC: 5 A resistance – 250 V Contact made from AgNI 90/10, gold-plated
Thermal protection (overheating)	70°C (automatic restart)
Operating cycle (duty factor)	100%
Protection (as per NF EN 60529)	IP64
Safety standard	CE
RoHS directive	Compliant
WEEE directive	Compliant

The pump discharge must be connected to the water pipe by a flexible transparent PVC type pipe with an internal diameter of 6 mm / external diameter of 9 mm (not supplied).

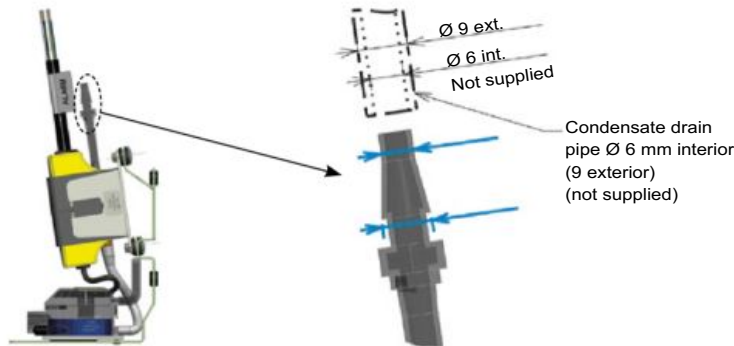

Discharge height	Water flow rate in litres per hour (-15 %/+ 20 %)			
	Horizontal length of the discharge pipe			
	5 metres	10 metres	20 metres	30 metres
1 metre	10,4	9,1	8,3	7,3
2 metres	8,5	7,8	7	6,4
3 metres	7,9	7,1	6,3	5,8
4 metres	7	6	5,3	4,9

The condensate drain pump has a safety contact to prevent overflow in the condensate drain pan in the event of problems with the drain. This NC (normally closed) contact connected to the control is used to shut down cooling mode to stop the production of condensates and switch the air handling unit to safety mode.



## CONTROL

The unit can be equipped with Carrier NTC or WTC control systems. These offer functions to suit the requirements of the various applications, summarised in the table below.

Functions	NTC	WTC
<b>Communication protocols</b>		
Carrier Communication Network (CCN) Aquasmart compatible	X	
BACnet MSTP		X
<b>Control algorithms</b>		
Proportional-integral	X	X
Carrier energy saving algorithm	X	X
<b>Fan control</b>		
Ventilation control only (control on the air, without hydraulic valve)		
Variable-speed EC motors	X	X
Automatic fan speed selection	X	X
Three manual speeds	X	X
<b>Water valve management</b>		
230 V on/off actuators	X	X
Floating 3-point 230 V actuators	X	X
Modulating PWM 230 V actuators		X
<b>Main functions</b>		
Setpoint control	X	X
Occupied/unoccupied mode	X	X
Frost protection mode	X	X
Window/door contact input	X	X
Measurement of water temperature for automatic changeover (2-tube)	X	X
Measurement of water inlet temperature to prevent cold draughts (4-tube and 2-tube)	X	X
Manual changeover	X	X
Frost protection mode	X	X
Continuous ventilation within deadband	X	X
Periodical ventilation within deadband	X	X
On-site configuration	X	X
Unit grouping (master/slave)	X	X
Supply air temperature management	X	X
Filter fouling alarm	X	X
Alarm reporting	X	X
Indoor Air Quality control (CO <sub>2</sub> sensor)	O	O
Demand-controlled ventilation (DCV) (0-10 V fresh air valve)	O	O
Free cooling mode		O
Presence detection		O
<b>User interfaces</b>		
Manual or automatic speed control	X	X
Setpoint adjustment	X	X
Occupancy (eco) button	X	O
LCD screen	O	O
Remote control (infrared)	O	O
CO <sub>2</sub> sensor	O	O
Motion detection		O

### Key

X Feature available as standard  
O Optional

**NOTE:** For the features and specifications of the Carrier controllers outlined above, refer to the technical documentation for each controller.



## DIMENSIONAL DRAWINGS

Model with sleeve on the supply air - Fresh air intake, coil side.

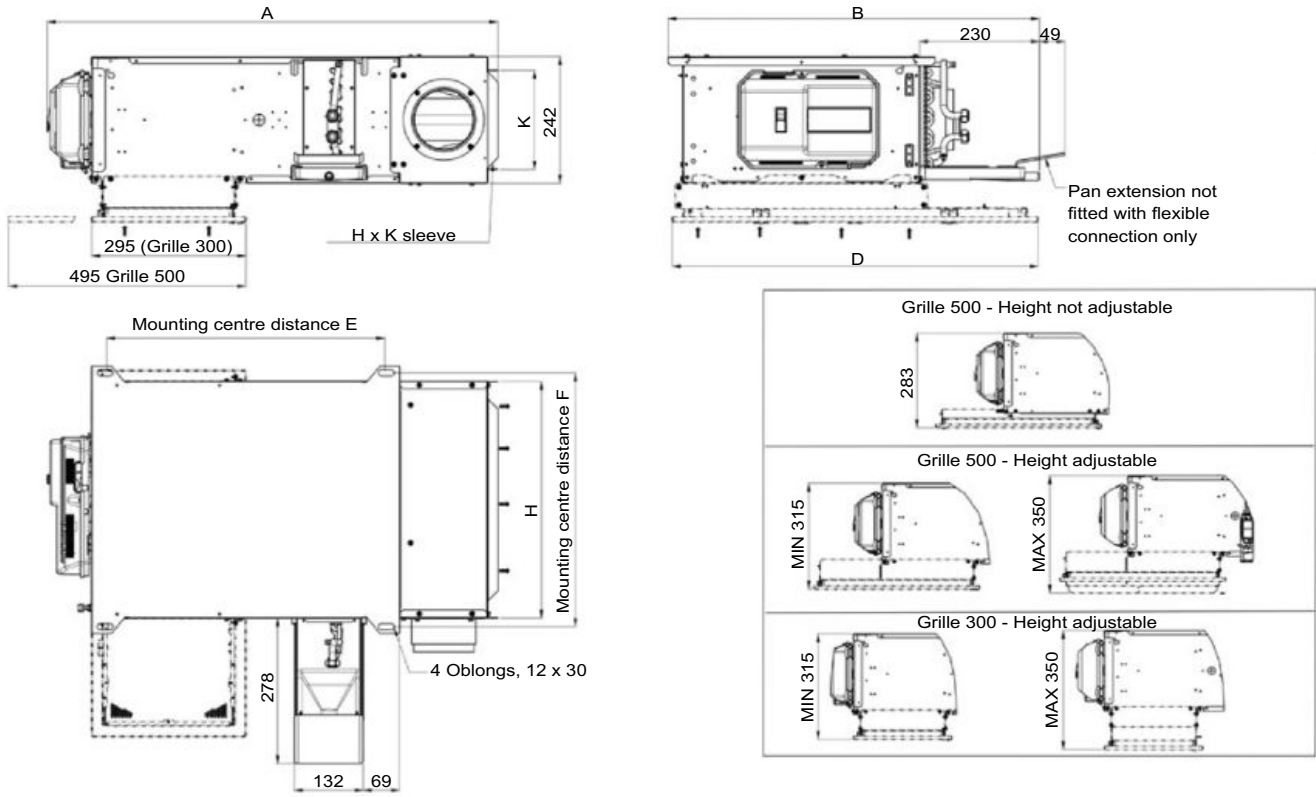

Sizes (mm)	A	B	D	E	F	H	K
T0	863	711	700/695	538	485	453	190
T2	883	877	700/860/1195	558	652	620	190
T3	883	1077	1060/1195	558	852	820	190

## DIMENSIONAL DRAWINGS

### Assembly with discharge grille

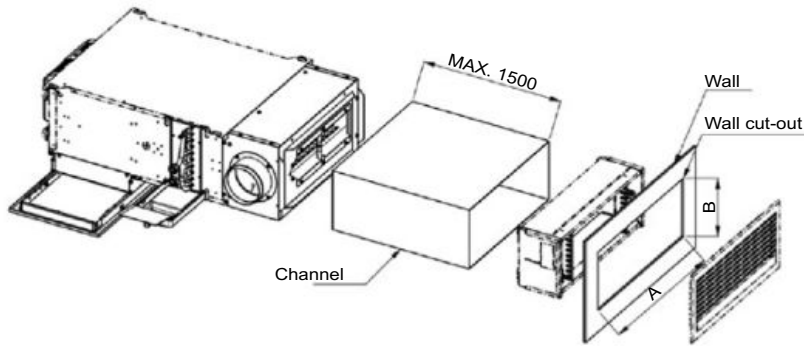
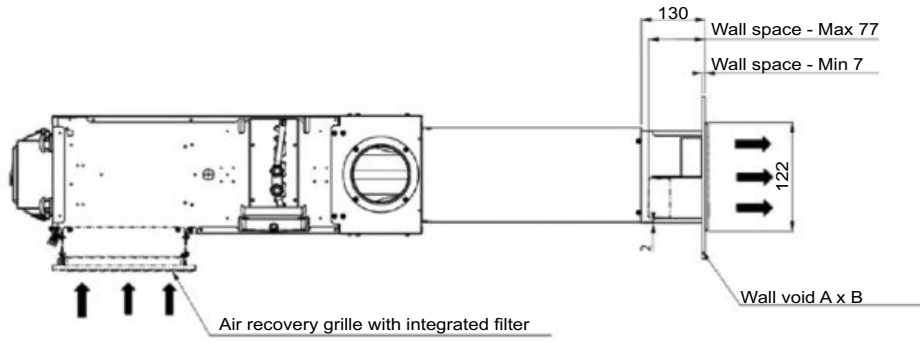

Size (mm)	A	B
T0	487	193
T2	654	193
T3	854	193

## DIMENSIONAL DRAWINGS

Model without sleeve on the supply air – Fresh air intake, coil side.

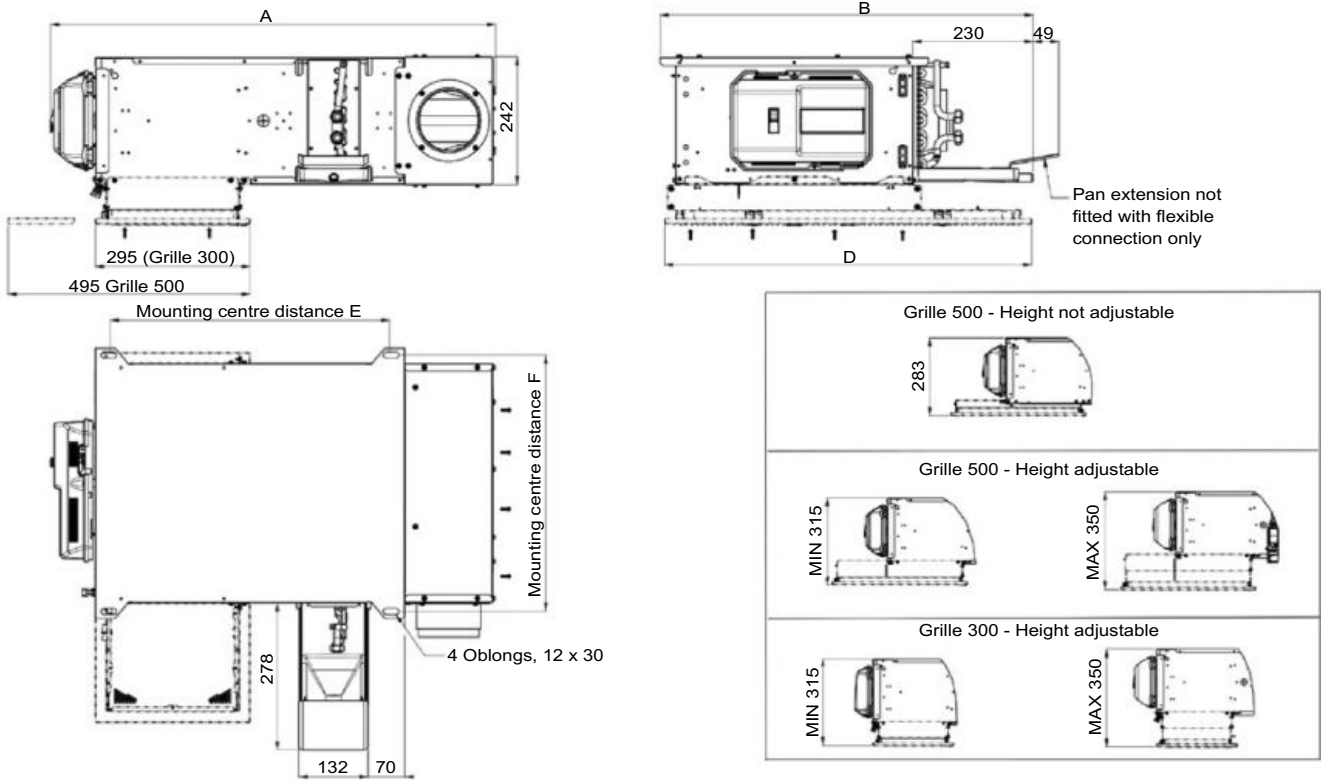

Size (mm)	A	B	D	E	F
T0	848	711	700/695	538	485
T2	868	877	700/860/1195	558	652
T3	868	1077	1060/1195	558	852

## DIMENSIONAL DRAWINGS

### Assembly with discharge grille fitted on the unit

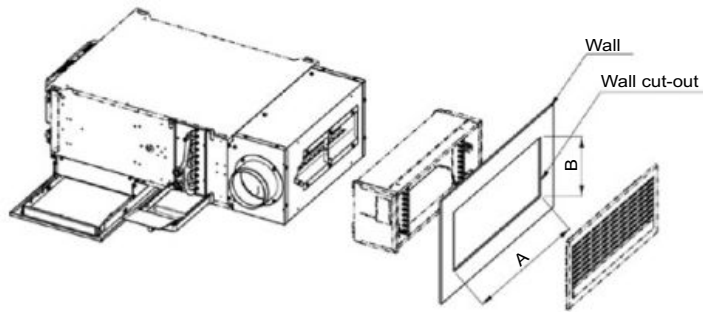
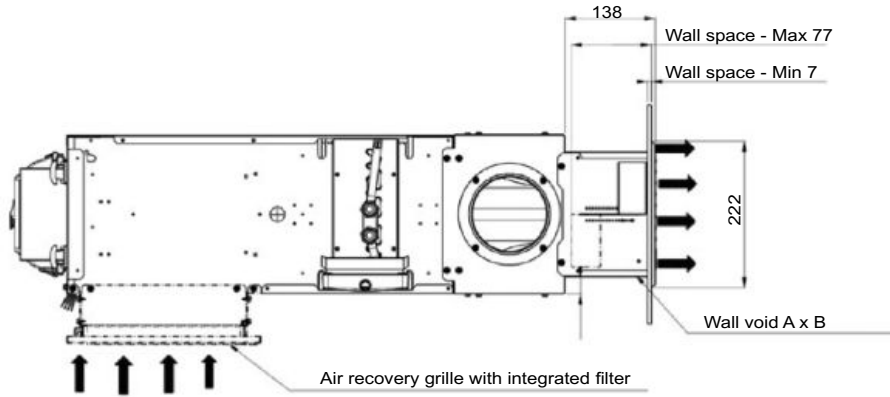

Size (mm)	A	B
T0	487	193
T2	654	193
T3	854	193

## PERFORMANCES

### 2-tube water coil

#### Cooling capacity - 2-tube

Room temperature: (dry bulb) = 27 °C and humidity = 47%

Fresh air temperature: 14 °C

With no discharge grille

#### Size 0

Fresh air m <sup>3</sup> /h	Motor voltage (V)	Total air flow rate (m <sup>3</sup> /h)	ESP (Pa)	Water temperature: 7-12 °C			Water temperature: 15-18 °C			* NR dB(A)	Lw dB(A)	Lp dB(A)
				Total capacity (kW)	Sensible capacity (kW)	Water flow rate (l/h)	Total capacity (kW)	Sensible capacity (kW)	Water flow rate (l/h)			
30	0	45	0	0,26	0,22	20	0,17	0,17	15	15	15	
	2	146	0	0,73	0,6	105	0,39	0,39	89	15	23	
	4	262	0	1,14	0,95	179	0,61	0,61	156	18	36	
	6	410	0	1,55	1,32	253	0,84	0,84	226	30	46	
	8	556	0	1,85	1,61	308	1,02	1,02	285	38	54	
60	0	90	0	0,48	0,42	36	0,33	0,33	28	15	15	
	2	182	0	0,88	0,75	109	0,51	0,51	93	15	23	
	4	298	0	1,27	1,08	182	0,71	0,71	159	18	36	
	6	446	0	1,67	1,44	255	0,92	0,92	229	30	46	
	8	592	0	1,96	1,72	311	1,09	1,09	288	38	54	
90	0	135	0	0,69	0,61	50	0,49	0,49	40	15	15	
	2	218	0	1,03	0,89	114	0,63	0,63	96	15	23	
	4	334	0	1,41	1,21	185	0,81	0,81	162	18	37	
	6	482	0	1,79	1,55	258	1,01	1,01	232	30	47	
	8	628	0	2,06	1,83	313	1,17	1,17	290	38	54	
120	0	180	0	0,88	0,79	61	0,63	0,63	51	15	15	
	2	254	0	1,18	1,03	118	0,75	0,75	100	15	23	
	4	370	0	1,54	1,34	189	0,92	0,92	165	18	37	
	6	518	0	1,91	1,68	261	1,1	1,1	234	30	47	
	8	664	0	2,17	1,94	315	1,26	1,26	292	38	54	
160	0	240	0	1,14	1,03	78	0,83	0,83	65	15	15	
	2	302	0	1,37	1,22	123	0,91	0,91	105	15	24	
	4	418	0	1,72	1,52	193	1,06	1,06	169	18	37	
	6	566	0	2,07	1,83	263	1,23	1,23	238	30	47	
	8	712	0	2,32	2,09	318	1,37	1,37	295	38	54	
200	0	300	0	1,39	1,27	93	1,02	1,02	78	15	15	
	2	350	0	1,57	1,41	129	1,08	1,08	110	15	24	
	4	466	0	1,9	1,7	197	1,21	1,21	173	19	37	
	6	614	0	2,23	2	266	1,37	1,37	241	30	47	
	8	760	0	2,48	2,24	321	1,5	1,5	298	38	55	

\* Sound level guidance with noise attenuation -13 dB(A), without discharge grille



## PERFORMANCES

### Size 2

Fresh air m <sup>3</sup> /h	Motor voltage (V)	Total air flow rate (m <sup>3</sup> /h)	ESP (Pa)	Water temperature: 7-12 °C			Water temperature: 15-18 °C			* NR dB(A)	Lw dB(A)	Lp dB(A)
				Total capacity (kW)	Sensible capacity (kW)	Water flow rate (l/h)	Total capacity (kW)	Sensible capacity (kW)	Water flow rate (l/h)			
30	0	45	0	0,27	0,23	22	0,18	0,18	16	15	15	15
	2	200	0	1,18	0,93	179	0,61	0,61	147	15	24	15
	4	353	0	1,89	1,52	304	0,97	0,97	257	18	36	23
	6	538	0	2,61	2,14	432	1,36	1,36	373	29	47	34
	8	714	0	3,2	2,67	536	1,68	1,68	473	37	54	41
60	0	90	0	0,52	0,45	41	0,35	0,35	31	15	15	15
	2	236	0	1,34	1,09	185	0,72	0,72	152	15	24	15
	4	389	0	2,04	1,67	309	1,08	1,08	261	18	36	23
	6	574	0	2,76	2,28	436	1,46	1,46	377	29	47	34
	8	750	0	3,33	2,8	540	1,77	1,77	476	37	54	41
90	0	135	0	0,76	0,66	59	0,51	0,51	45	15	15	15
	2	272	0	1,5	1,25	190	0,85	0,85	156	15	24	15
	4	425	0	2,2	1,82	313	1,19	1,19	265	18	37	24
	6	610	0	2,9	2,42	440	1,56	1,56	380	29	47	34
	8	786	0	3,46	2,93	543	1,86	1,86	479	37	54	41
120	0	180	0	0,98	0,86	75	0,68	0,68	58	15	15	15
	2	308	0	1,67	1,4	195	0,97	0,97	161	15	24	15
	4	461	0	2,35	1,96	318	1,3	1,3	269	18	37	24
	6	646	0	3,04	2,56	443	1,66	1,66	384	29	47	34
	8	822	0	3,59	3,06	546	1,95	1,95	482	37	54	41
160	0	240	0	1,27	1,13	94	0,89	0,89	75	15	15	15
	2	356	0	1,88	1,61	202	1,14	1,14	167	15	24	15
	4	509	0	2,55	2,16	323	1,46	1,46	274	18	37	24
	6	694	0	3,23	2,75	448	1,8	1,8	388	29	47	34
	8	870	0	3,77	3,24	551	2,08	2,08	486	37	54	41
200	0	300	0	1,55	1,39	113	1,09	1,09	92	15	15	15
	2	404	0	2,09	1,81	209	1,31	1,31	173	15	24	15
	4	557	0	2,75	2,36	329	1,61	1,61	279	18	37	24
	6	742	0	3,42	2,93	453	1,94	1,94	393	29	47	34
	8	918	0	3,95	3,42	555	2,22	2,22	490	37	54	41

\* Sound level guidance with noise attenuation -13 dB(A), without discharge grille

## PERFORMANCES

### Size 3

Fresh air m <sup>3</sup> /h	Motor voltage (V)	Total air flow rate (m <sup>3</sup> /h)	ESP (Pa)	Water temperature: 7-12 °C			Water temperature: 15-18 °C			* NR dB(A)	Lw dB(A)	Lp dB(A)
				Total capacity (kW)	Sensible capacity (kW)	Water flow rate (l/h)	Total capacity (kW)	Sensible capacity (kW)	Water flow rate (l/h)			
30	0	48	0	0,3	0,25	26	0,19	0,19	19	15	15	15
	2	272	0	1,48	1,19	233	0,83	0,83	213	15	25	15
	4	500	0	2,38	1,96	391	1,39	1,39	376	20	38	25
	6	790	0	3,32	2,8	557	1,99	1,99	557	31	48	35
	8	1072	0	4,03	3,48	687	2,48	2,48	711	40	56	43
60	0	96	0	0,57	0,48	49	0,37	0,37	38	15	15	15
	2	308	0	1,63	1,34	237	0,95	0,95	218	15	25	15
	4	536	0	2,52	2,09	395	1,49	1,49	380	20	38	25
	6	826	0	3,44	2,92	560	2,08	2,08	560	32	48	35
	8	1108	0	4,15	3,6	690	2,57	2,57	714	40	56	43
90	0	144	0	0,81	0,7	68	0,55	0,55	55	15	15	15
	2	344	0	1,79	1,49	242	1,07	1,07	222	15	25	15
	4	572	0	2,66	2,23	398	1,6	1,6	384	21	38	25
	6	862	0	3,57	3,05	563	2,18	2,18	564	32	48	35
	8	1144	0	4,26	3,71	692	2,65	2,65	717	40	56	43
120	0	192	0	1,05	0,91	86	0,72	0,72	72	15	15	15
	2	380	0	1,94	1,64	247	1,19	1,19	227	15	25	15
	4	608	0	2,8	2,37	402	1,71	1,71	388	21	38	25
	6	898	0	3,7	3,17	566	2,28	2,28	567	32	48	35
	8	1180	0	4,38	3,83	695	2,74	2,74	720	40	56	43
160	0	256	0	1,34	1,18	107	0,95	0,95	93	15	15	15
	2	428	0	2,15	1,83	253	1,36	1,36	233	15	26	15
	4	656	0	2,99	2,55	407	1,86	1,86	394	21	38	25
	6	946	0	3,87	3,34	570	2,41	2,41	572	32	48	35
	8	1228	0	4,54	3,99	698	2,87	2,87	724	40	56	43
200	0	320	0	1,63	1,46	129	1,17	1,17	113	15	15	15
	2	476	0	2,35	2,03	259	1,53	1,53	239	15	26	15
	4	704	0	3,18	2,74	412	2,01	2,01	399	21	38	25
	6	994	0	4,04	3,51	574	2,55	2,55	576	32	48	35
	8	1276	0	4,7	4,15	701	3	3	728	40	56	43

\* Sound level guidance with noise attenuation -13 dB(A), without discharge grille

## PERFORMANCES

### Heating capacity - 2-tube

Room temperature: 20 °C

Fresh air temperature: 20 °C

With no discharge grille

### Size 0

Fresh air m <sup>3</sup> /h	Motor voltage (V)	Total air flow rate (m <sup>3</sup> /h)	ESP (Pa)	Water temperature: 65-55 °C			Water temperature: 45-40 °C			* NR dB(A)	Lw dB(A)	Lp dB(A)
				Total capacity (kW)	Sensible capacity (kW)	Water flow rate (l/h)	Total capacity (kW)	Sensible capacity (kW)	Water flow rate (l/h)			
30	0	45	0	0,07	0,21	18	0,04	0,12	20	15	15	15
	2	146	0	1,02	1,29	111	0,57	0,72	123	15	23	15
	4	262	0	1,98	2,26	195	1,11	1,25	216	18	36	23
	6	410	0	3,01	3,28	283	1,69	1,82	313	30	46	33
	8	556	0	3,89	4,15	357	2,19	2,30	396	38	54	41
60	0	90	0	0,13	0,40	34	0,07	0,22	38	15	15	15
	2	182	0	0,9	1,35	116	0,5	0,75	129	15	23	15
	4	298	0	1,82	2,31	199	1,02	1,28	220	18	36	23
	6	446	0	2,84	3,32	286	1,6	1,84	317	30	46	33
	8	592	0	3,73	4,18	360	2,1	2,32	399	38	54	41
90	0	135	0	0,19	0,57	49	0,11	0,32	54	15	15	15
	2	218	0	0,82	1,40	121	0,46	0,78	134	15	23	15
	4	334	0	1,7	2,35	202	0,95	1,30	224	18	37	24
	6	482	0	2,71	3,36	289	1,52	1,86	320	30	47	34
	8	628	0	3,59	4,21	363	2,02	2,33	402	38	54	41
120	0	180	0	0,25	0,74	63	0,14	0,41	70	15	15	15
	2	254	0	0,77	1,46	125	0,43	0,81	139	15	23	15
	4	370	0	1,61	2,39	206	0,9	1,33	228	18	37	24
	6	518	0	2,59	3,39	292	1,45	1,88	324	30	47	34
	8	664	0	3,46	4,24	365	1,95	2,35	405	38	54	41
160	0	240	0	0,32	0,95	81	0,18	0,52	90	15	15	15
	2	302	0	0,72	1,53	132	0,4	0,85	146	15	24	15
	4	418	0	1,51	2,45	211	0,84	1,36	234	18	37	24
	6	566	0	2,46	3,44	297	1,38	1,91	329	30	47	34
	8	712	0	3,31	4,29	369	1,87	2,38	409	38	54	41
200	0	300	0	0,38	1,14	99	0,21	0,63	109	15	15	15
	2	350	0	0,69	1,60	138	0,38	0,88	152	15	24	15
	4	466	0	1,43	2,51	216	0,8	1,39	240	19	37	24
	6	614	0	2,35	3,49	301	1,32	1,94	333	30	47	34
	8	760	0	3,19	4,33	373	1,8	2,40	414	38	55	42

\* Sound level guidance with noise attenuation -13 dB(A), without discharge grille

## PERFORMANCES

### Size 2

Fresh air m <sup>3</sup> /h	Motor voltage (V)	Total air flow rate (m <sup>3</sup> /h)	ESP (Pa)	Water temperature: 65-55 °C			Water temperature: 45-40 °C			* NR dB(A)	Lw dB(A)	Lp dB(A)
				Total capacity (kW)	Sensible capacity (kW)	Water flow rate (l/h)	Total capacity (kW)	Sensible capacity (kW)	Water flow rate (l/h)			
30	0	45	0	0,07	0,22	19	0,04	0,12	21	15	15	15
	2	200	0	1,79	2,13	184	1	1,18	204	15	24	15
	4	353	0	3,36	3,72	320	1,88	2,06	356	18	36	23
	6	538	0	5,03	5,40	465	2,82	3,00	516	29	47	34
	8	714	0	6,48	6,84	589	3,64	3,79	653	37	54	41
60	0	90	0	0,14	0,43	37	0,08	0,24	41	15	15	15
	2	236	0	1,62	2,20	189	0,91	1,22	210	15	24	15
	4	389	0	3,15	3,78	325	1,77	2,10	361	18	36	23
	6	574	0	4,82	5,45	469	2,7	3,02	521	29	47	34
	8	750	0	6,27	6,88	593	3,52	3,82	658	37	54	41
90	0	135	0	0,21	0,63	54	0,12	0,35	60	15	15	15
	2	272	0	1,5	2,27	195	0,84	1,26	216	15	24	15
	4	425	0	2,99	3,84	330	1,67	2,13	367	18	37	24
	6	610	0	4,64	5,50	474	2,6	3,05	526	29	47	34
	8	786	0	6,08	6,93	597	3,42	3,85	662	37	54	41
120	0	180	0	0,28	0,82	71	0,15	0,46	78	15	15	15
	2	308	0	1,41	2,33	201	0,79	1,29	223	15	24	15
	4	461	0	2,85	3,89	335	1,6	2,16	372	18	37	24
	6	646	0	4,47	5,55	478	2,51	3,08	531	29	47	34
	8	822	0	5,91	6,98	601	3,32	3,87	667	37	54	41
160	0	240	0	0,36	1,08	93	0,2	0,60	103	15	15	15
	2	356	0	1,32	2,42	208	0,74	1,34	231	15	24	15
	4	509	0	2,7	3,97	342	1,51	2,20	379	18	37	24
	6	694	0	4,28	5,62	484	2,4	3,12	537	29	47	34
	8	870	0	5,7	7,04	606	3,21	3,91	673	37	54	41
200	0	300	0	0,44	1,32	114	0,25	0,73	126	15	15	15
	2	404	0	1,26	2,51	216	0,71	1,39	239	15	24	15
	4	557	0	2,57	4,05	348	1,44	2,24	387	18	37	24
	6	742	0	4,12	5,69	490	2,31	3,16	543	29	47	34
	8	918	0	5,52	7,10	611	3,1	3,94	679	37	54	41

\* Sound level guidance with noise attenuation -13 dB(A), without discharge grille

## PERFORMANCES

### Size 3

Fresh air m <sup>3</sup> /h	Motor voltage (V)	Total air flow rate (m <sup>3</sup> /h):	ESP (Pa)	Water temperature: 65-55 °C			Water temperature: 45-40 °C			* NR dB(A)	Lw dB(A)	Lp dB(A)
				Total capacity (kW)	Sensible capacity (kW)	Water flow rate (l/h)	Total capacity (kW)	Sensible capacity (kW)	Water flow rate (l/h)			
30	0	48	0	0,1	0,27	23	0,06	0,15	25	15	15	15
	2	272	0	2,69	3,07	265	1,51	1,70	293	15	25	15
	4	500	0	5,02	5,42	467	2,81	3,01	518	20	38	25
	6	790	0	7,61	8,01	690	4,26	4,44	765	31	48	35
	8	1072	0	9,86	10,25	883	5,54	5,68	979	40	56	43
60	0	96	0	0,2	0,52	45	0,11	0,29	50	15	15	15
	2	308	0	2,49	3,14	270	1,4	1,74	300	15	25	15
	4	536	0	4,8	5,48	472	2,69	3,04	523	20	38	25
	6	826	0	7,38	8,06	695	4,14	4,47	770	32	48	35
	8	1108	0	9,64	10,30	887	5,42	5,71	983	40	56	43
90	0	144	0	0,29	0,77	66	0,16	0,42	73	15	15	15
	2	344	0	2,34	3,20	276	1,31	1,78	306	15	25	15
	4	572	0	4,61	5,54	477	2,58	3,07	529	21	38	25
	6	862	0	7,18	8,11	699	4,02	4,50	775	32	48	35
	8	1144	0	9,44	10,34	891	5,3	5,73	988	40	56	43
120	0	192	0	0,38	1,01	87	0,21	0,56	96	15	15	15
	2	380	0	2,22	3,27	282	1,24	1,81	312	15	25	15
	4	608	0	4,44	5,59	482	2,48	3,10	534	21	38	25
	6	898	0	6,99	8,16	703	3,92	4,53	780	32	48	35
	8	1180	0	9,25	10,39	895	5,2	5,76	992	40	56	43
160	0	256	0	0,5	1,32	114	0,28	0,73	126	15	15	15
	2	428	0	2,09	3,36	289	1,17	1,86	321	15	26	15
	4	656	0	4,24	5,67	488	2,37	3,14	541	21	38	25
	6	946	0	6,76	8,23	709	3,79	4,56	786	32	48	35
	8	1228	0	9,01	10,45	900	5,06	5,79	998	40	56	43
200	0	320	0	0,61	1,62	140	0,34	0,90	155	15	15	15
	2	476	0	1,99	3,45	297	1,11	1,91	329	15	26	15
	4	704	0	4,07	5,75	495	2,28	3,18	549	21	38	25
	6	994	0	6,56	8,30	715	3,68	4,60	792	32	48	35
	8	1276	0	8,79	10,51	905	4,94	5,83	1004	40	56	43

\* Sound level guidance with noise attenuation -13 dB(A), without discharge grille



## PERFORMANCES

### 4-tube water coil

#### Cooling capacity - 4-tube

Room temperature: (dry bulb) = 27 °C and humidity = 47%

Fresh air temperature: 14 °C

With no discharge grille

#### Size 0

Fresh air m <sup>3</sup> /h	Motor voltage (V)	Total air flow rate (m <sup>3</sup> /h)	ESP (Pa)	Water temperature: 7-12 °C			Water temperature: 15-18 °C			* NR dB(A)	Lw dB(A)	Lp dB(A)
				Total capacity (kW)	Sensible capacity (kW)	Water flow rate (l/h)	Total capacity (kW)	Sensible capacity (kW)	Water flow rate (l/h)			
30	0	45	0	0,25	0,22	19	0,17	0,17	15	15	15	
	2	146	0	0,66	0,57	93	0,38	0,38	84	15	23	
	4	262	0	1,03	0,91	159	0,59	0,59	150	18	36	
	6	410	0	1,4	1,27	226	0,81	0,81	220	30	46	
	8	556	0	1,7	1,57	283	1	1	280	38	54	
60	0	90	0	0,47	0,42	35	0,33	0,33	27	15	15	
	2	182	0	0,79	0,71	96	0,49	0,49	88	15	23	
	4	298	0	1,15	1,03	162	0,68	0,68	153	18	36	
	6	446	0	1,51	1,38	229	0,9	0,9	223	30	46	
	8	592	0	1,8	1,67	285	1,07	1,07	283	38	54	
90	0	135	0	0,67	0,61	48	0,48	0,48	39	15	15	
	2	218	0	0,93	0,85	100	0,6	0,6	91	15	23	
	4	334	0	1,28	1,16	165	0,78	0,78	156	18	37	
	6	482	0	1,63	1,5	231	0,98	0,98	225	30	47	
	8	628	0	1,91	1,78	288	1,15	1,15	285	38	54	
120	0	180	0	0,86	0,79	59	0,63	0,63	49	15	15	
	2	254	0	1,07	0,99	103	0,72	0,72	95	15	23	
	4	370	0	1,41	1,29	168	0,89	0,89	159	18	37	
	6	518	0	1,74	1,61	234	1,08	1,08	228	30	47	
	8	664	0	2,02	1,89	290	1,24	1,24	288	38	54	
160	0	240	0	1,1	1,01	72	0,81	0,81	63	15	15	
	2	302	0	1,26	1,17	108	0,89	0,89	100	15	24	
	4	418	0	1,59	1,47	172	1,03	1,03	163	18	37	
	6	566	0	1,9	1,77	236	1,21	1,21	231	30	47	
	8	712	0	2,17	2,04	293	1,35	1,35	291	38	54	
200	0	300	0	1,32	1,24	84	1	1	75	15	15	
	2	350	0	1,45	1,36	113	1,05	1,05	105	15	24	
	4	466	0	1,76	1,64	175	1,18	1,18	167	19	37	
	6	614	0	2,06	1,93	240	1,34	1,34	235	30	47	
	8	760	0	2,32	2,19	296	1,48	1,48	294	38	55	

\* Sound level guidance with noise attenuation -13 dB(A), without discharge grille

## PERFORMANCES

### Size 2

Fresh air m <sup>3</sup> /h	Motor voltage (V)	Total air flow rate (m <sup>3</sup> /h)	ESP (Pa)	Water temperature: 7-12 °C			Water temperature: 15-18 °C			* NR dB(A)	Lw dB(A)	Lp dB(A)
				Total capacity (kW)	Sensible capacity (kW)	Water flow rate (l/h)	Total capacity (kW)	Sensible capacity (kW)	Water flow rate (l/h)			
30	0	45	0	0,25	0,22	20	0,17	0,17	15	15	15	
	2	200	0	1	0,82	151	0,53	0,53	128	15	24	
	4	353	0	1,57	1,31	251	0,83	0,83	218	18	36	
	6	538	0	2,12	1,8	349	1,13	1,13	311	29	47	
	8	714	0	2,55	2,21	428	1,37	1,37	389	37	54	
60	0	90	0	0,48	0,43	37	0,33	0,33	28	15	15	
	2	236	0	1,15	0,97	156	0,64	0,64	132	15	24	
	4	389	0	1,7	1,44	255	0,92	0,92	221	18	36	
	6	574	0	2,24	1,92	352	1,21	1,21	314	29	47	
	8	750	0	2,66	2,32	431	1,45	1,45	391	37	54	
90	0	135	0	0,7	0,62	51	0,49	0,49	41	15	15	
	2	272	0	1,3	1,11	160	0,75	0,75	136	15	24	
	4	425	0	1,83	1,57	258	1,02	1,02	225	18	37	
	6	610	0	2,36	2,04	355	1,3	1,3	317	29	47	
	8	786	0	2,77	2,43	433	1,53	1,53	394	37	54	
120	0	180	0	0,9	0,81	64	0,64	0,64	52	15	15	
	2	308	0	1,44	1,25	164	0,87	0,87	140	15	24	
	4	461	0	1,97	1,7	262	1,12	1,12	228	18	37	
	6	646	0	2,48	2,16	358	1,39	1,39	319	29	47	
	8	822	0	2,89	2,55	436	1,61	1,61	396	37	54	
160	0	240	0	1,16	1,05	80	0,84	0,84	67	15	15	
	2	356	0	1,64	1,45	170	1,03	1,03	145	15	24	
	4	509	0	2,15	1,88	266	1,27	1,27	232	18	37	
	6	694	0	2,65	2,33	362	1,52	1,52	323	29	47	
	8	870	0	3,04	2,7	439	1,73	1,73	399	37	54	
200	0	300	0	1,42	1,3	97	1,03	1,03	81	15	15	
	2	404	0	1,84	1,64	175	1,19	1,19	150	15	24	
	4	557	0	2,33	2,06	271	1,41	1,41	236	18	37	
	6	742	0	2,82	2,49	365	1,65	1,65	327	29	47	
	8	918	0	3,2	2,86	442	1,85	1,85	403	37	54	

\* Sound level guidance with noise attenuation -13 dB(A), without discharge grille

## PERFORMANCES

### Size 3

Fresh air m <sup>3</sup> /h	Motor voltage (V)	Total air flow rate (m <sup>3</sup> /h)	ESP (Pa)	Water temperature: 7-12 °C			Water temperature: 15-18 °C			* NR dB(A)	Lw dB(A)	Lp dB(A)
				Total capacity (kW)	Sensible capacity (kW)	Water flow rate (l/h)	Total capacity (kW)	Sensible capacity (kW)	Water flow rate (l/h)			
30	0	48	0	0,29	0,24	25	0,18	0,18	17	15	15	15
	2	272	0	1,5	1,19	236	0,61	0,61	156	15	25	15
	4	500	0	2,43	1,97	398	0,96	0,96	260	20	38	25
	6	790	0	3,35	2,79	561	1,32	1,32	370	31	48	35
	8	1072	0	4,05	3,46	689	1,59	1,59	462	40	56	43
60	0	96	0	0,55	0,47	47	0,34	0,34	32	15	15	15
	2	308	0	1,65	1,34	241	0,7	0,7	159	15	25	15
	4	536	0	2,57	2,1	402	1,03	1,03	263	20	38	25
	6	826	0	3,47	2,91	564	1,38	1,38	372	32	48	35
	8	1108	0	4,16	3,58	692	1,65	1,65	463	40	56	43
90	0	144	0	0,79	0,69	66	0,49	0,49	46	15	15	15
	2	344	0	1,81	1,49	245	0,8	0,8	162	15	25	15
	4	572	0	2,69	2,23	403	1,12	1,12	265	21	38	25
	6	862	0	3,6	3,04	567	1,45	1,45	374	32	48	35
	8	1144	0	4,28	3,69	695	1,71	1,71	465	40	56	43
120	0	192	0	1,03	0,9	84	0,64	0,64	58	15	15	15
	2	380	0	1,96	1,64	250	0,91	0,91	165	15	25	15
	4	608	0	2,83	2,37	407	1,2	1,2	268	21	38	25
	6	898	0	3,72	3,16	570	1,52	1,52	376	32	48	35
	8	1180	0	4,39	3,81	697	1,78	1,78	467	40	56	43
160	0	256	0	1,33	1,18	106	0,83	0,83	73	15	15	15
	2	428	0	2,17	1,84	256	1,05	1,05	169	15	26	15
	4	656	0	3,02	2,55	412	1,33	1,33	271	21	38	25
	6	946	0	3,89	3,33	574	1,63	1,63	379	32	48	35
	8	1228	0	4,55	3,96	701	1,87	1,87	470	40	56	43
200	0	320	0	1,63	1,45	129	1,02	1,02	87	15	15	15
	2	476	0	2,37	2,03	262	1,2	1,2	173	15	26	15
	4	704	0	3,2	2,73	417	1,45	1,45	274	21	38	25
	6	994	0	4,06	3,5	578	1,74	1,74	382	32	48	35
	8	1276	0	4,71	4,12	704	1,97	1,97	472	40	56	43

\* Sound level guidance with noise attenuation -13 dB(A), without discharge grille

## PERFORMANCES

### Heating capacity - 4-tube

Room temperature: 20 °C

Fresh air temperature: 20 °C

With no discharge grille

### Size 0

Fresh air m <sup>3</sup> /h	Motor voltage (V)	Total air flow rate (m <sup>3</sup> /h)	ESP (Pa)	Water temperature: 65-55 °C			Water temperature: 45-40 °C			* NR dB(A)	Lw dB(A)	Lp dB(A)
				Total capacity (kW)	Sensible capacity (kW)	Water flow rate (l/h)	Total capacity (kW)	Sensible capacity (kW)	Water flow rate (l/h)			
30	0	45	0	0,04	0,13	11	0,02	0,07	12	15	15	15
	2	146	0	0,5	0,64	55	0,28	0,35	60	15	23	15
	4	262	0	0,92	1,05	90	0,51	0,58	100	18	36	23
	6	410	0	1,35	1,46	126	0,76	0,81	139	30	46	33
	8	556	0	1,7	1,79	155	0,97	0,99	171	38	54	41
60	0	90	0	0,08	0,22	19	0,04	0,13	22	15	15	15
	2	182	0	0,44	0,66	57	0,25	0,36	63	15	23	15
	4	298	0	0,85	1,07	92	0,47	0,59	101	18	36	23
	6	446	0	1,27	1,47	127	0,72	0,82	141	30	46	33
	8	592	0	1,63	1,81	156	0,93	1,00	172	38	54	41
90	0	135	0	0,1	0,31	26	0,06	0,17	29	15	15	15
	2	218	0	0,4	0,68	59	0,22	0,38	65	15	23	15
	4	334	0	0,79	1,09	94	0,44	0,60	103	18	37	24
	6	482	0	1,21	1,49	128	0,68	0,82	142	30	47	34
	8	628	0	1,57	1,82	157	0,89	1,01	173	38	54	41
120	0	180	0	0,13	0,38	33	0,07	0,21	37	15	15	15
	2	254	0	0,37	0,71	61	0,21	0,39	67	15	23	15
	4	370	0	0,75	1,11	95	0,42	0,61	105	18	37	24
	6	518	0	1,16	1,50	130	0,65	0,83	143	30	47	34
	8	664	0	1,52	1,83	158	0,86	1,02	175	38	54	41
160	0	240	0	0,16	0,48	41	0,09	0,26	46	15	15	15
	2	302	0	0,35	0,74	64	0,19	0,41	70	15	24	15
	4	418	0	0,7	1,13	97	0,39	0,62	107	18	37	24
	6	566	0	1,1	1,52	131	0,62	0,84	145	30	47	34
	8	712	0	1,45	1,85	160	0,83	1,02	177	38	54	41
200	0	300	0	0,19	0,57	49	0,11	0,31	54	15	15	15
	2	350	0	0,33	0,77	66	0,19	0,42	73	15	24	15
	4	466	0	0,66	1,15	99	0,37	0,64	110	19	37	24
	6	614	0	1,04	1,54	133	0,59	0,85	147	30	47	34
	8	760	0	1,4	1,87	161	0,79	1,03	178	38	55	42

\* Sound level guidance with noise attenuation -13 dB(A), without discharge grille

## PERFORMANCES

### Size 2

Fresh air m <sup>3</sup> /h	Motor voltage (V)	Total air flow rate (m <sup>3</sup> /h)	ESP (Pa)	Water temperature: 65-55 °C			Water temperature: 45-40 °C			* NR dB(A)	Lw dB(A)	Lp dB(A)
				Total capacity (kW)	Sensible capacity (kW)	Water flow rate (l/h)	Total capacity (kW)	Sensible capacity (kW)	Water flow rate (l/h)			
30	0	45	0	0,05	0,14	12	0,03	0,08	13	15	15	15
	2	200	0	0,81	0,96	83	0,45	0,53	91	15	24	15
	4	353	0	1,37	1,52	131	0,77	0,84	145	18	36	23
	6	538	0	1,93	2,06	177	1,09	1,14	196	29	47	34
	8	714	0	2,39	2,50	215	1,35	1,38	238	37	54	41
60	0	90	0	0,08	0,24	21	0,05	0,14	23	15	15	15
	2	236	0	0,73	0,98	85	0,41	0,54	94	15	24	15
	4	389	0	1,29	1,54	132	0,72	0,85	147	18	36	23
	6	574	0	1,84	2,07	178	1,04	1,15	198	29	47	34
	8	750	0	2,31	2,51	216	1,31	1,39	240	37	54	41
90	0	135	0	0,11	0,34	29	0,06	0,19	32	15	15	15
	2	272	0	0,67	1,01	87	0,37	0,56	96	15	24	15
	4	425	0	1,22	1,55	134	0,68	0,86	149	18	37	24
	6	610	0	1,77	2,09	180	1	1,16	199	29	47	34
	8	786	0	2,24	2,52	217	1,27	1,40	241	37	54	41
120	0	180	0	0,14	0,43	37	0,08	0,24	41	15	15	15
	2	308	0	0,63	1,03	89	0,35	0,57	98	15	24	15
	4	461	0	1,16	1,57	136	0,65	0,87	150	18	37	24
	6	646	0	1,71	2,10	181	0,96	1,17	201	29	47	34
	8	822	0	2,17	2,54	218	1,23	1,41	242	37	54	41
160	0	240	0	0,18	0,54	46	0,1	0,30	51	15	15	15
	2	356	0	0,58	1,06	92	0,33	0,59	101	15	24	15
	4	509	0	1,09	1,60	138	0,61	0,89	153	18	37	24
	6	694	0	1,63	2,12	183	0,92	1,18	203	29	47	34
	8	870	0	2,1	2,56	220	1,19	1,42	244	37	54	41
200	0	300	0	0,22	0,64	55	0,12	0,36	61	15	15	15
	2	404	0	0,55	1,10	94	0,31	0,61	104	15	24	15
	4	557	0	1,04	1,62	140	0,58	0,90	155	18	37	24
	6	742	0	1,57	2,15	185	0,88	1,19	205	29	47	34
	8	918	0	2,03	2,57	222	1,15	1,43	246	37	54	41

\* Sound level guidance with noise attenuation -13 dB(A), without discharge grille



## PERFORMANCES

### Size 3

Fresh air m <sup>3</sup> /h	Motor voltage (V)	Total air flow rate (m <sup>3</sup> /h)	ESP (Pa)	Water temperature: 65-55 °C			Water temperature: 45-40 °C			* NR dB(A)	Lw dB(A)	Lp dB(A)
				Total capacity (kW)	Sensible capacity (kW)	Water flow rate (l/h)	Total capacity (kW)	Sensible capacity (kW)	Water flow rate (l/h)			
30	0	48	0	0,06	0,17	14	0,04	0,09	16	15	15	15
	2	272	0	1,21	1,38	118	0,68	0,76	132	15	25	15
	4	500	0	2,04	2,20	189	1,15	1,22	210	20	38	25
	6	790	0	2,9	3,03	261	1,63	1,68	290	31	48	35
	8	1072	0	3,62	3,72	321	2,06	2,07	356	40	56	43
60	0	96	0	0,11	0,30	26	0,06	0,17	29	15	15	15
	2	308	0	1,12	1,40	121	0,63	0,78	134	15	25	15
	4	536	0	1,95	2,22	191	1,1	1,23	212	20	38	25
	6	826	0	2,81	3,05	263	1,58	1,69	292	32	48	35
	8	1108	0	3,54	3,74	322	2,01	2,08	358	40	56	43
90	0	144	0	0,16	0,43	37	0,09	0,24	41	15	15	15
	2	344	0	1,04	1,42	123	0,59	0,79	136	15	25	15
	4	572	0	1,87	2,24	193	1,05	1,24	214	21	38	25
	6	862	0	2,73	3,06	264	1,54	1,70	293	32	48	35
	8	1144	0	3,47	3,75	323	1,97	2,08	359	40	56	43
120	0	192	0	0,2	0,54	46	0,11	0,30	51	15	15	15
	2	380	0	0,98	1,45	125	0,55	0,81	139	15	25	15
	4	608	0	1,79	2,26	194	1,01	1,25	216	21	38	25
	6	898	0	2,65	3,08	265	1,5	1,71	295	32	48	35
	8	1180	0	3,39	3,77	324	1,93	2,09	360	40	56	43
160	0	256	0	0,26	0,68	58	0,14	0,38	65	15	15	15
	2	428	0	0,92	1,48	128	0,52	0,82	142	15	26	15
	4	656	0	1,71	2,28	196	0,96	1,27	218	21	38	25
	6	946	0	2,56	3,10	267	1,45	1,72	297	32	48	35
	8	1228	0	3,31	3,78	326	1,88	2,10	362	40	56	43
200	0	320	0	0,3	0,81	70	0,17	0,45	77	15	15	15
	2	476	0	0,87	1,51	130	0,49	0,84	145	15	26	15
	4	704	0	1,64	2,31	199	0,92	1,28	221	21	38	25
	6	994	0	2,48	3,12	269	1,4	1,73	299	32	48	35
	8	1276	0	3,22	3,80	328	1,83	2,11	364	40	56	43

\* Sound level guidance with noise attenuation -13 dB(A), without discharge grille

## AIR HEATERS DESTRATIFIER



The best solution for heating and/or cooling large spaces

Ensures buildings warm up ultra fast

Excellent diffusion via patented JET+ double deflection technology

Available with low consumption EC motor

Destratifier version for better air mixing in heating mode

# 42AM 42AMA

In wall-mounted or ceiling-mounted versions, the **air heater** is the simple, affordable heating/cooling solution for all your applications: for your premises in the tertiary sector (sales area, gym, multi-purpose rooms etc.) or in industry (workshop, garage, storage unit, logistics platform, etc.).

The air heater may have associated **destratifiers** (42AMA-) to promote mixing of the building air. (Anti-stratification solution).

The 42AM range meets APSAD and NFPA guidelines on unit peripheral air speeds.

All are less than 5 m/s at 0.5 m from the diffuser and thus do not interfere with sprinkler systems.

## RANGE

### Heating version

Heating/cooling medium	LP water	HP superheated water - Oil	HP steam
<b>AC motor</b>	THREE-PHASE 2-speed – SINGLE-PHASE 1 variable speed IP 44 (42AM-AC35) and IP54 (42AM-AC40 to 42AM-AC63)		
<b>Reinforced variant</b>	CORROBLOC version – IP 55/65 – 700-hour salt spray test		
<b>Coil (tubing/row)</b>	Copper/Alu	316L stainless steel/Alu	316L stainless steel/Alu
<b>Reinforced versions</b>	316L stainless steel pipes/HERESITE coating	HERESITE coating	
<b>Casing</b>	Precoated off-white (RAL 7035) galvanised steel		
<b>Reinforced versions</b>	304L stainless steel		
<b>ATEX versions</b>	LCIE 13 ATEX 1015 X – Zone 2 – IIB or IIC – T4 or T6		

### Heating or Cooling version

Heating/cooling medium	LP water
<b>EC motor</b>	Variable speed single-phase with 0-10 V signal IP 54 (42AM-EC30 and 42AM-EC35) and IP55 (42AM-EC40 to 42AM-EC63)
<b>Coil (tubing/row)</b>	Copper/Alu
<b>Reinforced versions</b>	316L stainless steel pipes/HERESITE coating
<b>Casing</b>	Off-white precoated galvanised steel (RAL 7035) Built-in condensate pan + quick-release fitting for cooling
<b>Reinforced versions</b>	304L stainless steel

## CODES

Product ref.	Range							Series		Size				Model	Coil	Thermal function	Sp. option	Modif. index
	4	2	A	M	-	A	C	3	5	1	M	0	-	s	0	H	I	A
Digit	1	2	3	4	5	6	7	8	9	10	11	12	13	14	15	16	17	18
<b>Digits 1 to 7</b>								<b>Digits 8&amp;9</b>		<b>Digit 14</b>				<b>Digit 17</b>				
42AM-AC: AC motor air heater- Digit 16 = H, C, P or S								30*		S = Suspended-Digit 16 = H or -				- = NONE				
42AM-EC: EC motor air heater - Digit 16 = H or C								35		M = Wall-mounted only				I = Stainless steel casing				
42AM-EX: ATEX air heater - Digit 16 = H, C, P or S								40						C = Corroblock FMA - If 42AM-AC				
42AMAAC: AC motor destratifier - Digit 16 = -								45**						H = Heresite-coated coil - Digit 16 = H,C,P or S				
42AMAEC: EC motor destratifier - Digit 16 = -								50						A = Altena-coated coil - Digit 16 = H,C,P or S				
								63***		<b>Digit 15</b>				J = I+C				
								64****		- = NONE (for 42AMAAC and 42AMAEC)				K = I+H				
										0 = 2 standard pipes				L = C+H				
										1 = 2 stainless steel pipes				M = I+A				
														N = C+A				
														O = I+C+H				
														P = I+C+A				
<b>Digits 10 to 13</b>																		
42AM-AC	1M0- = 1 row 1-ph/230 V FMA with AC motor - Digit 16 = H, P or S																	
	3M0H = 3 rows 1-ph/230 V FMA with AC motor - Heating - Digit 16 = H																	
	1T0- = 1 row 3-ph/400 V FMA with AC motor - Digit 16 = H, P or S																	
	3T0- = 3 rows 3-ph/400 V FMA with AC motor - Digit 16 = H																	
42AM-EC	1M9- = 1 row 1-ph/230 V FMA with EC motor- Digit 16 = H																	
	2M9H = 2 rows 1-ph/230 V FMA with EC motor - Digit 8&9 =30 and Digit 16 = H																	
	2M9C = 2 rows 1-ph/230 V FMA with EC motor - Digit 8&9 =30 and Digit 16 = C or R																	
	3M9H = 3 rows 1-ph/230 V FMA with EC motor - HEATING - Digit 16 = H																	
	3M9C = 3 rows 1-ph/230 V FMA with EC motor - Cooling or Heating/Cooling - Digit 16 = C																	
42AM-EX (Gaseous atmospheres and Zone 2 only)	1T1- = 1 row 380 V/3-ph - ATEX IIBT4 motor (gas) - Digit 16 = H, P or S																	
	3T1H = 3 rows 380 V/3-ph - ATEX IIBT4 motor (gas) - Digit 16 = H																	
	3T1C = 3 rows 380 V/3-ph - ATEX IIBT4 motor (gas)- Cooling or Heating/Cooling-Digit 16 = C																	
	1T2- = 1 row 380 V/3-ph - ATEX IIBT5 motor (gas) - Digit 16 = H, P or S																	
	3T2H= 3 rows 380 V/3-ph - ATEX IIBT5 motor (gas) - Heating - Digit 16 = H																	
	3T2C= 3 rows 380 V/3-ph - ATEX IIBT5 motor (gas)- Cooling or Heating/Cooling-Digit 16 = C																	
	1T3- = 1 row 380 V/3-ph - ATEX IICT4 motor (gas) - Digit 16 = H, P or S																	
	3T3H= 3 rows 380 V/3-ph - ATEX IICT4 motor (gas) - Heating - Digit 16 = H																	
	3T3C= 3 rows 380 V/3-ph - ATEX IICT4 motor (gas)- Cooling or Heating/Cooling-Digit 16 = C																	
	1T4- = 1 row 380 V/3-ph - ATEX IICT6 motor (gas) - Digit 16 = H, P or S																	
3T4H= 3 rows 380 V/3-ph - ATEX IICT6 motor (gas) - Heating - Digit 16 = H																		
3T4C= 3 rows 380 V/3-ph - ATEX IICT6 motor (gas)- Cooling or Heating/Cooling-Digit 16 = C																		
42AMAAC	-M0- = 1-ph/230 V FMA with AC motor- Cooling or Heating/Cooling-Digit 16 = -																	
	-T0- = 3-ph/400 V FMA with AC motor- Cooling or Heating/Cooling-Digit 16 = -																	
42AMAEC	-M9- = 1-ph/230 V FMA with EC motor- Cooling or Heating/Cooling-Digit 16 = -																	

\* If 42AM-EC  
 \*\* If Digit 16 = H, C or -  
 \*\*\* 42AM-AC: If Digit 16 = H, P or S  
 \*\*\* 42AM-EC: If Digit 16 = H or C  
 \*\*\* 42AM-EX: Not available  
 \*\*\*\* 42AM-AC: If Digit 16 = H

Units in Hot Water only, Superheated Water or Steam versions are delivered as standard with left-hand connection (opposite the air heater). Right-hand connection is possible simply by reversing the unit.

Units in Cold Water only or Hot Water/Cold Water versions are delivered as standard with left-hand connection. To request right-hand connection, please consult us.

ATEX versions are only available with left-hand connection.

## TECHNICAL DESCRIPTION

### High-efficiency fan motor assembly

Silent FMA with an epoxy polyester-coated aluminium airfoil propeller to ensure the best compromise between air flow efficiency and acoustic comfort.

The ROTOREX design with windings inserted in the fan hub, keeps the motor cool to ensure that it operates at optimum efficiency.



#### Available versions:

- THREE-PHASE 2 speeds (accessory: LS/HS switch)
- SINGLE-PHASE 1 variable speed (accessory: 5-speed autotransformer)

### Low consumption EC FMA

Fan motor assembly equipped with a powerful high-efficiency EC (electronically commutated) motor. These EC motors (single-phase 230 V drive) will be progressively controlled by the 0-10 V signal, to ensure acoustic comfort and air flow efficiency and to optimise consumption of electricity. A shunt can be used to operate the air heater at maximum speed.

#### Casing

- Elegant galvanised steel casing, pre-painted in RAL 7035 (light grey).
- Built-in condensate drain pan for cooling applications, featuring an antibacterial design (perforated bottom) and quick-release fitting.
- Inlet cone optimised for improved air flow performance and acoustic comfort level.
- Advantages:
  - Its classic design means that it can easily blend into the architecture of the installation site.
  - No need to add an unsightly condensate drain pan.
  - Condensate pipes quick and extremely simple to connect, without any need for a clamp.

#### Diffuser

Double deflection diffuser made from rigid aluminium sections, based on the BERNOULLI fluid flow principle and on NACA0012 airfoils, creating a high induction rate on the primary air, in order to increase the air streams, limit the stratification phenomenon and thereby reduce energy consumption.

### Basic version on request for a minimum quantity of 15 units (one size available only: 42AM-AC641T0-M0H):

- Single-deflection diffuser with directional louvre
- Light-grey galvanised steel louvre

### JET+ version (fitted as standard):

- Double-deflection diffuser
- JET+ aluminium louvre with NACA0012 airfoil design
- Each louvre is directional
- Advantages:
  - Air flows adjustable in 4 directions for optimum coverage of the area to be handled, while limiting draughts.
  - Laminar flow of the airstream for improved acoustic comfort (no turbulence at the diffuser outlet).
  - Increased velocity of the air streams thanks to the aerodynamics of the curved airfoil (low pressure on the underside of the wing) increases the coverage of the air streams and the induction rate.
  - Limits stratification.
  - Reduced building warm-up time:
  - Recorded energy savings of 15 to 20%.

### Heat exchanger

HIGH EFFICIENCY heat exchanger coil with tapered intake baffles to help pressurise the finned casing, available in the following versions:

#### LP hot or cold water version – Available with 1 or 3 rows:

- Copper pipe Ø 9.52 mm
- Embossed aluminium fins – Thickness 10/100 mm
- Fin spacing 2.1 mm
- Equilateral geometry 32 mm
- Advantage: Excellent thermal yield (dry transfer coefficient > 50 W/m<sup>2</sup>.k)

#### HP superheated water version- Oil – Available with 1 row:

- 316L stainless steel Ø 16 mm thick pipe
- Embossed aluminium fins – Thickness 28.5/100 mm
- Fin spacing 2.5 mm
- Can be used with heat transfer oils
- Advantage: robust aluminium finned casing for industrial environments (polluted air) compatible with high-pressure jet washing.

#### HP steam version – Available with 1 row:

- 316L stainless steel Ø 16 mm thick pipe
- Embossed aluminium fins – Thickness 28.5/100 mm
- Fin spacing 2.5 mm
- Advantage: excellent corrosion resistance thanks to chemical treatments injected into the steam installation pipe networks.



## TECHNICAL DESCRIPTION

### Control

A range of "Plug & Play" proportional air-source/water-source controllers with heat exchanger (or electric heater) are used to control the air flow of the fan motor assembly and the heating capacity required for the room, according to the occupancy periods (built-in timer).

Single-phase EC FMA + LP water application:

- The single-phase EC BOX can control:
  - 6 H4000 single-phase ECs
  - 6 TPL 4000 single-phase ECs
  - 3 H4000 single-phase ECs + 3 TPL single-phase ECs
  - 4 H4000 single-phase ECs + 2 TPL single-phase ECs

### Options and accessories

- Wall bracket, ceiling bracket, IPN additional kit
- Filter box
- Specific diffuser (on door, high-level etc.)
- Room thermostat for THREE-PHASE or SINGLE-PHASE installation
- LS/HS switch for 3-PH fan motor assembly
- 5-speed autotransformer for single-phase AC FMAs
- Proximity switch
- Circuit breaker unit

### By special request:

- ATEX air heater

## 42AM PERFORMANCE SUPERHEATED WATER AND STEAM 230 V/1-PH/50 HZ MOTOR - AC AND EC

HEATING operation - 230 V/1-ph/50 Hz motor - AC and EC									
Model	No. rows	Supply air speed SINGLE-PHASE	Flow rate m <sup>3</sup> /h	Air speed m/s	Range (metres)		Heating capacity (kW)		Sound pressure
					Wall-mounted	Suspended	SW	HPS	dB(A)
30	2	Direct	1 420	3.16 m/s	15	3			45
35	1	Direct	2 600	3.92 m/s	22	6	29	32	48
		R3*	2 360	3.56 m/s	18	4	27	29	46
	3	Direct	2 075	3.13 m/s	15	2,5			50
		R3*	1 780	2.68 m/s	14	2			48
40	1	Direct	4 200	4.57 m/s	26	8,5	43	46	54
		R3*	3 914	4.26 m/s	24	7,5	39	42	52
	3	Direct	3 450	3.75 m/s	23	7			56
		R3*	3 220	3.50 m/s	20	5,5			54
45	1	Direct	5 200	4.20 m/s	27	8,5			56
		R3*	4 100	3.31 m/s	24	6			49
	3	Direct	4 550	3.68 m/s	18	3,5			59
		R3*	3 650	2.95 m/s	17	3			52
50	1	Direct	7 100	4.22 m/s	28	9	79	77	56
		R3*	5 700	3.39 m/s	26	7	66	70	50
	3	Direct	6 200	3.69 m/s	24	6,5			58
		R3*	5 055	3.01 m/s	23	5,5			52
63	1	Direct	10 450	4.19 m/s	28	10,5	103	107	54
		R3*	8 900	3.57 m/s	22	8	93	98	47
	3	Direct	8 280	3.32 m/s	21	6,5			56
		R3*	6 270	2.52 m/s	19	5			44

HEATING - COOLING operation - 230 V/1-ph/50 Hz motor - EC						
Model	No. rows	Supply air speed	Air flow rate	Air speed	Range (metres)	Sound pressure
			m <sup>3</sup> /h	m/s	Wall-mounted	dB(A)
30M9 (EC)	2	Direct	1200	2.67 m/s	12	43
35M9 (EC)	3	Direct	1640	2.47 m/s	23	30
40M9 (EC)			2160	2.35 m/s	26	48
45M9 (EC)			3025	2.44 m/s	24	45
50M9 (EC)			4060	2.41 m/s	23	54
63M9 (EC)			5960	2.39 m/s	21	53

### Specifications determined using the following information:

- **Superheated water (ES HP):** temperature: 180 - 120 °C / TR=15 °C – RH 50 %
- **Steam (VAP HP):** temperature 175 °C – 8 bar / TR=15 °C – RH 50 %
- **Cooling:** temperature 7 - 12 °C / TR=27 °C – RH 50 %
- **Air stream:** \* with JET+ diffuser for a residual speed of 0.1 m/s
- \* defined with a  $\Delta t$  TS/TR of 15 °C (heating) and 7 °C (cooling)
- \* for LP water operation
- **Air speed:** JET+ diffuser outlet
- **Sound pressure:** 5 metres from the unit, directivity 2, attenuation of 22 dB
- **Direct:** speed obtained when wired directly to single-phase motor.
- **R3\*** (version with AC motor): supply air speed obtained with an autotransformer at 3. Other operation points (5 in total) can be supplied on request by your agent using our technical selection software.

## 42AM PERFORMANCE SUPERHEATED WATER AND STEAM 400 V/3-PH/50 HZ MOTOR

HEATING operation - 400 V/3-ph/50 Hz motor - AC									
Model	No. rows	Supply air speed THREE-PHASE	Flow rate m <sup>3</sup> /h	Air speed m/s	Range (metres)		Heating capacity (kW)		Sound pressure dB(A)
					Wall-mounted	Suspended	SW	HPS	
35	1	HS	2 600	3.92 m/s	22	6	29	32	48
		LS	2 210	3.33 m/s	17	3,5	27	29	44
	3	HS	2 165	3.26 m/s	18	4,5			50
		LS	1 775	2.67 m/s	14	2			46
40	1	HS	4 000	4.35 m/s	25	8	42,7	45,7	55
		LS	3 480	3.79 m/s	21	5	38	41	51
	3	HS	3 400	3.70 m/s	22	6,5			56
		LS	2 960	3.22 m/s	17	3,5			52
45	1	HS	5 400	4.36 m/s	28	9			56
		LS	3 910	3.16 m/s	23	5,5			49
	3	HS	5 000	4.04 m/s	24	7,5			59
		LS	3 910	3.16 m/s	20	4			52
50	1	HS	7 500	4.46 m/s	30	10	79,4	77,4	56
		LS	5 740	3.41 m/s	26	7	66,2	70,1	50
	3	HS	6 500	3.86 m/s	26	8,5			58
		LS	5 020	2.98 m/s	23	5,5			52
63	1	HS	11 140	4.47 m/s	29	11,5	110	115	55
		LS	9 635	3.87 m/s	24	8,5	100	105	48
	3	HS	9 175	3.68 m/s	25	10			57
		LS	7 545	3.03 m/s	21	7			49

### Specifications determined using the following information:

- **Superheated water (ES HP):** temperature: 180 - 120 °C / TR=15 °C – RH 50 %
- **Steam (VAP HP):** temperature 175 °C – 8 bar / TR=15 °C – RH 50 %
- **Air stream:** \* with JET+ diffuser for a residual speed of 0.1 m/s

\* defined with a  $\Delta t$  TS/TR of 15 °C  
\* for LP water operation

- **Air speed:** JET+ diffuser outlet
- **Sound pressure:** 5 metres from the unit, directivity 2, attenuation of 22 dB

## DESTRATIFIER DETERMINATION AND SELECTION EXAMPLE (42AMA)

The use of 42AMA units is recommended for buildings between 5 and 15 metres high.

S = Supply (released at the top of the building)

TR = Temperature under roof

TW = Temperature setpoint in the work area

$$\text{Calculated flow rate for destratifiers} = \frac{A}{0.3 \times (TR-TW)}$$

Selection example:

Supply under building roof = S = 45,000 kcal (52,200 Watts)

Temperature under roof = TR = 30°C

Temperature setpoint in the work area = TW = 16°C

$$\text{Calculated flow rate for destratifiers} = \frac{45\,000}{0.3 \times (30-16)} = 10714 \text{ m}^3/\text{h}$$

Either: 2 X 42AMA-50---T0 at HS or 1 x 42AMA-63---T0 at HS.

## 42AMA AIR FLOW & ACOUSTIC PERFORMANCE

42AMA-	40		45		50		63		
	HS	LS	HS	LS	HS	LS	HS	LS	
THREE-PHASE motor (3-phase 400 V coupling)	△	★	△	★	△	★	△	★	
SINGLE-PHASE AC and SINGLE-PHASE EC motor	Direct	-	Direct	-	Direct	-	Direct	-	
Flow rate	m <sup>3</sup> /h	4400	3000	6000	4100	8000	5500	11500	8800
Air stream	m	15	8	14	9	16	10	19	14
Sound pressure	dB(A)	51	43	54	46	57	47	55	50

Specifications determined using the following information:

**Air stream:** \* with JET+ diffuser for a residual speed of 0.1 m/s

**Sound pressure:**\* measured 8 metres from unit, directivity 2, attenuation of 26 dB

## 42AM - HOT WATER - 230 V/1-PH/50 HZ MOTOR - AC AND EC

Inlet/Outlet water temperature, °C		42AM--302*				42AM--351							
		Air flow rate (m <sup>3</sup> /h) Direct				Air flow rate (m <sup>3</sup> /h) Direct				Air flow rate (m <sup>3</sup> /h) R3*			
		1420				2600				2360			
		Air inlet dry-bulb temperature (°C)				Air inlet dry-bulb temperature (°C)				Air inlet dry-bulb temperature (°C)			
		8	12	15	18	8	12	15	18	8	12	15	18
80-60	Hc	17,1	15,8	14,8	13,9	11,9	11	10,3	9,62	11,5	10,6	9,93	9,28
	PD	42,7	36,8	32,7	28,9	7,91	6,95	6,11	5,4	7,41	6,42	5,73	5,07
60-40	Hc	10,7	9,4	8,46	7,52	7,12	6,19	5,49	4,77	6,87	5,97	5,29	4,6
	PD	18,4	14,6	12	9,65	3,37	2,63	2,12	1,65	3,17	2,46	1,99	1,55
45-40	Hc					7,08	6,17	5,49	4,81	6,83	5,95	5,29	4,65
	PD					40,4	31,7	25,7	20,3	37,9	29,5	24	19,1
50-42	Hc					7,52	6,62	5,94	5,27	7,26	6,38	5,74	5,09
	PD					19,3	15,3	12,6	10,1	18,1	14,4	11,9	9,52

Inlet/Outlet water temperature, °C		42AM--353								42AM--401							
		Air flow rate (m <sup>3</sup> /h) Direct				Air flow rate (m <sup>3</sup> /h) R3*				Air flow rate (m <sup>3</sup> /h) Direct				Air flow rate (m <sup>3</sup> /h) R3*			
		2075				1780				4200				3914			
		Air inlet dry-bulb temperature (°C)				Air inlet dry-bulb temperature (°C)				Air inlet dry-bulb temperature (°C)				Air inlet dry-bulb temperature (°C)			
		8	12	15	18	8	12	15	18	8	12	15	18	8	12	15	18
80-60	Hc	25,9	23,9	22,3	20,8	23,7	21,8	20,4	19	17,2	15,9	14,9	13,9	16,8	15,5	14,5	13,5
	PD	7,65	6,53	5,77	5,03	6,43	5,5	4,87	4,24	7,24	6,25	5,55	4,9	6,91	5,96	5,3	4,68
60-40	Hc	15,5	13,4	11,9	10,4	14,1	12,3	10,8	9,45	10,2	8,81	7,78	6,72	9,93	8,58	7,58	6,55
	PD	3	2,29	1,82	1,43	2,51	1,93	1,54	1,21	2,99	2,3	1,85	1,42	2,86	2,2	1,76	1,36
45-40	Hc	15,2	13,2	11,7	10,3	13,8	12	10,7	9,35	10,3	8,97	7,98	6,99	10	8,74	7,77	6,81
	PD	40	30,3	24,4	18,9	33,5	25,6	20,4	15,8	38,1	29,5	23,8	18,7	36,3	28,1	22,6	17,9
50-42	Hc	16,3	14,3	12,8	11,3	14,8	13	11,7	10,3	10,9	9,6	8,61	7,62	10,6	9,35	8,39	7,43
	PD	18,5	14,4	11,7	9,29	15,5	12,1	9,81	7,81	17,9	14	11,5	9,22	17,1	13,4	11	8,79

## 42AM - HOT WATER - 230 V/1-PH/50 HZ MOTOR - AC AND EC

Inlet/Outlet water temperature, °C		42AM--403								42AM--451							
		Air flow rate (m³/h) Direct				Air flow rate (m³/h) R3*				Air flow rate (m³/h) Direct				Air flow rate (m³/h) R3*			
		3450				3220				5200				4100			
		Air inlet dry-bulb temperature (°C)				Air inlet dry-bulb temperature (°C)				Air inlet dry-bulb temperature (°C)				Air inlet dry-bulb temperature (°C)			
		8	12	15	18	8	12	15	18	8	12	15	18	8	12	15	18
80-60	Hc	40,1	36,9	34,6	32,3	38,6	35,5	33,2	31	23,4	21,6	20,3	19	21,3	19,7	18,5	17,3
	PD	13,3	11,4	10,1	8,9	12,3	10,6	9,37	8,26	14,6	12,7	11,3	10	12,4	10,7	9,55	8,46
60-40	Hc	24,2	20,9	18,5	16,1	23,2	20,1	17,8	15,5	14,3	12,5	11,2	9,92	13,1	11,5	10,2	9,01
	PD	5,47	4,22	3,36	2,63	5,09	3,93	3,13	2,45	6,43	5,12	4,2	3,37	5,5	4,34	3,57	2,83
45-40	Hc	23,5	20,4	18,2	15,9	22,6	19,6	17,4	15,3	13,7	12	10,7	9,38	12,5	10,9	9,71	8,53
	PD	67,9	52,4	42,2	32,9	63,2	48,7	39	30,6	72,4	56,8	45,9	36,5	61,3	48	38,9	30,8
50-42	Hc	25,2	22,1	19,8	17,5	24,2	21,2	19	16,8	14,7	12,9	11,6	10,3	13,4	11,8	10,6	9,42
	PD	32,1	25,1	20,5	16,4	29,8	23,3	19	15,2	34,9	27,8	23	18,6	29,5	23,6	19,5	15,8

Inlet/Outlet water temperature, °C		42AM--453								42AM--501							
		Air flow rate (m³/h) Direct				Air flow rate (m³/h) R3*				Air flow rate (m³/h) Direct				Air flow rate (m³/h) R3*			
		4550				3650				7100				5700			
		Air inlet dry-bulb temperature (°C)				Air inlet dry-bulb temperature (°C)				Air inlet dry-bulb temperature (°C)				Air inlet dry-bulb temperature (°C)			
		8	12	15	18	8	12	15	18	8	12	15	18	8	12	15	18
80-60	Hc	54,4	50,2	47	43,8	47,8	44	41,2	38,5	31	28,6	26,9	25,1	28,5	26,3	24,7	23,1
	PD	13,5	11,6	10,3	9,02	10,6	9,08	8,04	7,06	7,9	6,84	6,1	5,4	6,8	5,89	5,25	4,65
60-40	Hc	33,5	29,3	26,1	22,9	29,4	25,6	22,8	20	18,6	16,2	14,3	12,5	17,1	14,8	13,1	11,4
	PD	5,69	4,44	3,57	2,81	4,47	3,46	2,8	2,18	3,39	2,65	2,13	1,66	2,92	2,27	1,83	1,42
45-40	Hc	31,6	27,5	24,4	21,4	27,6	24	21,3	18,7	18,4	16,1	14,3	12,5	16,9	14,7	13,1	11,5
	PD	68,6	53	42,4	33,2	53,5	41	33	25,7	40,3	31,4	25,5	20,2	34,5	26,9	21,8	17,3
50-42	Hc	34	29,8	26,8	23,7	29,7	26,1	23,4	20,8	19,6	17,2	15,5	13,7	18	15,8	14,2	12,6
	PD	32,5	25,4	20,8	16,6	25,3	19,9	16,2	12,9	19,2	15,2	12,6	10,1	16,6	13,1	10,9	8,69

Inlet/Outlet water temperature, °C		42AM--503								42AM--631							
		Air flow rate (m³/h) Direct				Air flow rate (m³/h) R3*				Air flow rate (m³/h) Direct				Air flow rate (m³/h) R3*			
		6200				5055				10450				8900			
		Air inlet dry-bulb temperature (°C)				Air inlet dry-bulb temperature (°C)				Air inlet dry-bulb temperature (°C)				Air inlet dry-bulb temperature (°C)			
		8	12	15	18	8	12	15	18	8	12	15	18	8	12	15	18
80-60	Hc	74,3	68,4	64,1	59,8	65,9	60,8	56,9	53,1	45,4	41,9	39,3	36,7	42,7	39,4	37	34,5
	PD	12,8	11	9,74	8,56	10,3	8,81	7,8	6,87	6,89	5,94	5,28	4,65	6,16	5,32	4,72	4,16
60-40	Hc	45,8	40,1	35,7	31,3	40,7	35,5	31,7	27,8	26,9	23,3	20,6	17,8	25,3	21,9	19,3	16,7
	PD	5,46	4,27	3,44	2,71	4,39	3,42	2,77	2,17	2,79	2,14	1,71	1,32	2,5	1,91	1,53	1,19
45-40	Hc	43,1	37,5	33,3	29,2	38,2	33,2	29,5	25,9	27,2	23,7	21	18,5	25,5	22,2	19,8	17,3
	PD	64,8	49,9	39,9	31,4	51,6	39,9	32	25	36,3	28,1	22,7	17,9	32,4	25,1	20,3	15,9
50-42	Hc	46,3	40,7	36,5	32,4	41,1	36,1	32,4	28,8	28,8	25,3	22,7	20,1	27,1	23,8	21,4	18,9
	PD	30,7	24,1	19,7	15,7	24,5	19,3	15,7	12,6	17	13,4	11	8,75	15,1	12	9,77	7,81

Inlet/Outlet water temperature, °C		42AM--633							
		Air flow rate (m³/h) Direct				Air flow rate (m³/h) R3*			
		8280				6270			
		Air inlet dry-bulb temperature (°C)				Air inlet dry-bulb temperature (°C)			
		8	12	15	18	8	12	15	18
80-60	Hc	106	97,5	91,4	85,4	89,1	82,2	77	72
	PD	21,5	18,3	16,2	14,3	15,5	13,3	11,8	10,4
60-40	Hc	66,1	58,2	52,3	46,3	56	49,2	44	38,9
	PD	9,2	7,26	5,94	4,76	6,74	5,31	4,31	3,43
45-40	Hc	/	53,1	47,3	41,5	51,1	44,5	39,7	34,9
	PD	/	82,5	66,5	52,2	76,9	59,2	47,7	37,6
50-42	Hc	65,8	57,9	52,1	46,3	55,3	48,7	43,8	38,9
	PD	50,9	40,1	32,8	26,3	36,8	28,9	23,8	19

Hc Heating capacity (kW)  
 PD Water pressure drop (kPa)  
 \* Only available in EC version



42AM - CHILLED WATER & HOT WATER - 230 V/1-PH/50 HZ MOTOR - EC

Inlet/Outlet water temperature, °C	42AM--302*				42AM--353				42AM--403				42AM--453				42AM--503				42AM--633*							
	Air flow rate (m³/h) - Direct				Air flow rate (m³/h) - Direct				Air flow rate (m³/h) - Direct				Air flow rate (m³/h) - Direct				Air flow rate (m³/h) - Direct				Air flow rate (m³/h) - Direct							
	1200				1640				2160				3025				4060				4060							
	Air inlet dry-bulb temperature (°C)				Air inlet dry-bulb temperature (°C)				Air inlet dry-bulb temperature (°C)				Air inlet dry-bulb temperature (°C)				Air inlet dry-bulb temperature (°C)				Air inlet dry-bulb temperature (°C)							
	8	12	15	18	8	12	15	18	8	12	15	18	8	12	15	18	8	12	15	18	8	12	15	18	8	12	15	18
80-60	Hc	17,1	15,8	14,8	13,9	21,4	19,7	18,5	17,2	28,9	26,6	24,9	23,2	40,6	37,4	35,1	32,8	54,9	50,6	47,4	44,3	82	75,7	71	66,4			
	PD	42,7	36,8	32,7	28,9	5,32	4,5	4	3,5	7,2	6,2	5,5	4,8	7,8	6,7	6	5,2	7,3	6,3	5,6	4,9	13,2	11,4	10,1	8,9			
60-40	Hc	10,7	9,4	8,46	7,52	12,8	11,1	9,8	8,6	17,3	15	13,3	11,7	25	21,9	19,5	17,1	33,9	29,6	26,4	23,2	51,6	45,4	40,6	35,9			
	PD	18,4	14,6	12	9,65	2,1	1,6	1,3	1	3	2,3	1,9	1,5	3,3	2,6	2,1	1,7	3,1	2,4	2	1,6	5,8	4,6	3,7	3			
45-40	Hc					12,5	10,9	9,7	8,5	16,8	14,6	13	11,4	23,5	20,5	18,2	16	31,7	27,6	24,6	21,6	46	41,1	36,6	32,2			
	PD					27,6	21,3	16,9	13,1	36,6	28,4	22,7	17,8	39,4	30,6	24,5	19,2	36,5	28,3	22,8	17,9	44,9	51,1	41,2	32,4			

Inlet/Outlet water temperature, °C	42AM--302*				42AM--353				42AM--403				42AM--453				42AM--503				42AM--633*			
	Relative humidity 50%				Relative humidity 50%				Relative humidity 50%				Relative humidity 50%				Relative humidity 50%				Relative humidity 50%			
	Air flow rate (m³/h) Direct				Air flow rate (m³/h) Direct				Air flow rate (m³/h) Direct				Air flow rate (m³/h) Direct				Air flow rate (m³/h) Direct				Air flow rate (m³/h) Direct			
	1200				1640				2160				3025				4060				5960			
	Air inlet dry-bulb temperature (°C)				Air inlet dry-bulb temperature (°C)				Air inlet dry-bulb temperature (°C)				Air inlet dry-bulb temperature (°C)				Air inlet dry-bulb temperature (°C)				Air inlet dry-bulb temperature (°C)			
	23	25	27	23	25	27	23	25	27	23	25	27	23	25	27	23	25	27	23	25	27	23	25	27
7-12	TCC	2,95	3,65	4,59	3,38	4,28	5,6	4,6	5,91	7,64	7,13	8,87	11,6	9,66	12,1	15,7	15,2	19,3	24,4					
	SCC	2,95	3,5	3,99	3,38	4,28	5,17	4,6	5,85	6,98	7,13	8,67	10,2	9,66	11,8	13,7	15,2	18,2	20,8					
	PD	24,4	36,1	55	2,34	3,69	6,22	3,46	5,55	9,08	4,44	6,75	11,3	4,22	6,55	10,7	8,46	13,3	20,6					
8-13	Hc	2,69	3,28	4,06	2,96	3,9	4,93	4,04	5,3	6,71	6,39	8,08	10,2	8,66	10,9	13,9	13,8	17,1	21,7					
	SCC	2,69	3,24	3,75	2,96	3,9	4,78	4,04	5,3	6,46	6,39	8,02	9,47	8,66	10,9	12,9	13,8	16,8	19,6					
	PD	20,4	29,5	43,8	1,82	3,1	4,86	2,68	4,53	7,06	3,6	5,65	8,76	3,43	5,37	8,52	6,98	10,6	16,5					
10-15	TCC	2,15	2,71	3,31	2,16	3,1	3,99	2,92	4,22	5,43	4,84	6,54	8,19	6,55	8,86	11,1	10,8	14	17,3					
	SCC	2,15	2,71	3,26	2,16	3,1	3,99	2,92	4,22	5,43	4,84	6,54	8,12	6,55	8,86	11	10,8	14	16,9					
	PD	13,4	20,6	29,7	0,993	1,98	3,22	1,43	2,92	4,74	2,11	3,75	5,79	2,01	3,57	5,5	4,38	7,11	10,7					

Hc Heating capacity (kW)  
 TCC Total cooling capacity  
 SCC Sensible cooling capacity (kW)  
 PD Water pressure drop (kPa)  
 \* Only available in EC version

### 42AM - HOT WATER - 400 V/3-PH/50 HZ MOTOR - AC

Inlet/Outlet water temperature, °C		42AM--351								42AM--353							
		Air flow rate (m³/h) HS				Air flow rate (m³/h) LS				Air flow rate (m³/h) HS				Air flow rate (m³/h) LS			
		2600				2210				2165				1775			
		Air inlet dry-bulb temperature (°C)				Air inlet dry-bulb temperature (°C)				Air inlet dry-bulb temperature (°C)				Air inlet dry-bulb temperature (°C)			
		8	12	15	18	8	12	15	18	8	12	15	18	8	12	15	18
80-60	Hc	11,9	11	10,3	9,62	11,2	10,3	9,69	9,05	26,6	24,5	22,9	21,4	23,7	21,8	20,4	19
	PD	7,92	6,86	6,12	5,41	7,09	6,14	5,48	4,84	8,04	6,86	6,07	5,3	6,42	5,49	4,86	4,24
60-40	Hc	7,13	6,2	5,5	4,78	6,71	5,83	5,17	4,49	15,9	13,8	12,2	10,7	14,1	12,3	10,8	9,47
	PD	3,38	2,63	2,13	1,66	3,03	2,36	1,9	1,48	3,15	2,4	1,91	1,5	2,51	1,93	1,55	1,21
45-40	Hc	7,08	6,18	5,5	4,82	6,66	5,8	5,16	4,53	15,6	13,6	12,1	10,6	13,8	12	10,7	9,36
	PD	40,5	31,7	25,7	20,3	36,3	28,3	22,9	18,3	42	32,4	25,7	20	33,5	25,6	20,4	15,8
50-42	Hc	7,53	6,63	5,95	5,28	7,08	6,23	5,59	4,96	16,7	14,7	13,1	11,6	14,8	13	11,7	10,3
	PD	19,3	15,3	12,7	10,2	17,3	13,7	11,3	9,11	19,5	15,2	12,3	9,79	15,5	12,1	9,82	7,82

Inlet/Outlet water temperature, °C		42AM--401								42AM--403							
		Air flow rate (m³/h) HS				Air flow rate (m³/h) LS				Air flow rate (m³/h) HS				Air flow rate (m³/h) LS			
		4000				3480				3400				2960			
		Air inlet dry-bulb temperature (°C)				Air inlet dry-bulb temperature (°C)				Air inlet dry-bulb temperature (°C)				Air inlet dry-bulb temperature (°C)			
		8	12	15	18	8	12	15	18	8	12	15	18	8	12	15	18
80-60	Hc	16,9	15,6	14,6	13,6	16,1	14,8	13,9	13	39,8	36,6	34,3	32	36,8	33,8	31,7	29,5
	PD	7,01	6,04	5,37	4,74	6,38	5,51	4,9	4,33	13,1	11,2	9,92	8,76	11,3	9,69	8,63	7,55
60-40	Hc	10	8,65	7,64	6,6	9,51	8,21	7,26	6,29	24	20,8	18,4	16	22,1	19,2	17	14,8
	PD	2,9	2,23	1,79	1,37	2,65	2,03	1,63	1,27	5,39	4,16	3,31	2,59	4,66	3,58	2,88	2,26
45-40	Hc	10,1	8,81	7,83	6,86	9,61	8,37	7,44	6,52	23,3	20,3	18	15,8	21,5	18,7	16,6	14,6
	PD	36,8	28,5	23	18,1	33,5	26	21	16,4	66,9	51,6	41,6	32,4	57,6	44,5	35,7	28
50-42	Hc	10,7	9,42	8,45	7,48	10,2	8,96	8,03	7,11	25	21,9	19,6	17,4	23,1	20,2	18,1	16,1
	PD	17,3	13,6	11,1	8,91	15,7	12,4	10,1	8,13	31,6	24,7	20,2	16,1	27,4	21,3	7,4	13,9

Inlet/Outlet water temperature, °C		42AM--451								42AM--453							
		Air flow rate (m³/h) HS				Air flow rate (m³/h) LS				Air flow rate (m³/h) HS				Air flow rate (m³/h) LS			
		5400				3910				5000				3910			
		Air inlet dry-bulb temperature (°C)				Air inlet dry-bulb temperature (°C)				Air inlet dry-bulb temperature (°C)				Air inlet dry-bulb temperature (°C)			
		8	12	15	18	8	12	15	18	8	12	15	18	8	12	15	18
80-60	Hc	23,7	21,9	20,6	19,2	21	19,4	18,2	17	57,4	52,9	49,6	46,2	49,8	45,9	43	40,1
	PD	14,9	13	11,6	10,2	12	10,4	9,24	8,19	15	12,8	11,3	9,97	11,5	9,84	8,71	7,65
60-40	Hc	14,5	12,7	11,4	10,1	12,8	11,3	10,1	8,84	35,3	30,9	27,5	24,1	30,7	26,8	23,9	20,9
	PD	6,58	5,24	4,31	3,45	5,32	4,23	3,46	2,74	6,27	4,89	3,95	3,1	4,84	3,76	3,03	2,37
45-40	Hc	13,9	12,1	10,8	9,5	12,3	10,7	9,54	8,38	33,4	29	25,8	22,6	28,9	25,1	22,3	19,6
	PD	74,2	58,2	47,3	37,4	59,3	46,4	37,7	29,9	76,5	58,7	47	36,7	58,1	44,7	35,9	28
50-42	Hc	14,9	13,1	11,8	10,5	13,1	11,6	10,4	9,25	35,8	31,5	28,3	25,1	31,1	27,3	24,5	21,7
	PD	35,7	28,5	23,6	19,1	28,6	22,8	18,8	15,3	35,9	28,1	23	18,3	27,4	21,6	17,6	14

Inlet/Outlet water temperature, °C		42AM--501								42AM--503							
		Air flow rate (m³/h) HS				Air flow rate (m³/h) LS				Air flow rate (m³/h) HS				Air flow rate (m³/h) LS			
		7500				5740				6500				5020			
		Air inlet dry-bulb temperature (°C)				Air inlet dry-bulb temperature (°C)				Air inlet dry-bulb temperature (°C)				Air inlet dry-bulb temperature (°C)			
		8	12	15	18	8	12	15	18	8	12	15	18	8	12	15	18
80-60	Hc	31,7	29,2	27,4	25,6	28,6	26,4	24,8	23,2	76,4	70,4	65,9	61,6	65,7	60,6	56,7	53
	PD	8,2	7,1	6,33	5,6	6,84	5,93	5,29	4,68	13,5	11,6	10,3	9,03	10,2	8,76	7,16	6,83
60-40	Hc	19	16,5	14,6	12,7	17,2	14,9	13,2	11,5	47,1	41,2	36,8	32,3	40,6	35,5	31,6	27,7
	PD	3,51	2,75	2,21	1,73	2,94	2,28	1,84	1,43	5,75	4,49	3,67	2,86	4,37	3,4	2,76	2,16
45-40	Hc	18,8	16,4	14,6	12,8	17	14,8	13,2	11,6	44,4	38,6	34,3	30,1	38,1	33,1	29,5	25,8
	PD	41,9	32,6	26,4	20,9	34,8	27,1	22	17,5	68,5	52,7	42,3	33,1	51,3	39,7	31,8	24,9
50-42	Hc	20	17,6	15,8	14	18,1	15,9	14,3	12,7	47,7	41,9	37,6	33,4	41	36	32,3	28,7
	PD	19,9	15,8	13	10,5	16,7	13,2	10,9	8,77	32,4	25,4	20,8	16,6	24,4	19,2	15,7	12,5

Hc Heating capacity (kW)  
PD Water pressure drop (kPa)

## 42AM - HOT WATER - 400 V/3-PH/50 HZ MOTOR - AC

Inlet/Outlet water temperature, °C		42AM--631								42AM--633							
		Air flow rate (m³/h) HS				Air flow rate (m³/h) LS				Air flow rate (m³/h) HS				Air flow rate (m³/h) LS			
		11140				9635				9175				7545			
		Air inlet dry-bulb temperature (°C)				Air inlet dry-bulb temperature (°C)				Air inlet dry-bulb temperature (°C)				Air inlet dry-bulb temperature (°C)			
		8	12	15	18	8	12	15	18	8	12	15	18	8	12	15	18
80-60	Hc	46,5	42,9	40,2	37,5	44,1	40,7	38,1	35,6	112	103	97	90,6	100	92,2	86,5	80,8
	PD	7,19	6,2	5,5	4,85	6,51	5,62	4,99	4,4	24	20,5	18,2	16	19,2	16,5	14,6	12,9
60-40	Hc	27,6	23,9	21	18,2	26,1	22,6	19,9	17,2	70	61,7	55,4	49,1	62,7	55,1	49,5	43,7
	PD	2,91	2,24	1,78	1,38	2,64	2,02	1,61	1,25	10,2	8,1	6,6	5,3	8,36	6,56	2,17	4,26
45-40	Hc	27,8	24,2	21,5	18,9	26,3	22,9	20,4	17,9	/	56,4	50,2	44,1	57,6	50,1	44,6	39,2
	PD	37,9	29,4	23,7	18,6	34,3	26,6	21,5	16,9	/	92,9	74,5	58,3	96,6	74,2	59,5	46,7
50-42	Hc	15,7	25,9	23,3	20,6	16,4	24,6	22	19,5	29,9	61,5	55,3	49,1	31,6	54,7	49,2	43,8
	PD	17,7	13,9	11,5	9,12	16	12,6	10,3	8,26	56,9	44,8	36,8	29,4	45,6	36,1	29,5	23,8

Hc Heating capacity (kW)  
PD Water pressure drop (kPa)

## ELECTRIC MOTOR SPECIFICATIONS

Use	Family	Size	Motor	Speed of rotation (rpm)	Nom. current A	P. Abs W	IP	Thermal cut-out	Class	Operating T°				
HEATING	42AM--	35H	THREE-PHASE 230/400 V - 50 Hz	HS - Δ 1385	0,35	110	44	NO	F	-40°C / +60°C				
				LS - ★ 1175	0,15	70								
	42AM--/42AMA-	40H/40-		HS - Δ 1404	0,5	260								
				LS - ★ 1176	0,3	170								
	42AM--/42AMA-	45H/45-		HS - Δ 1385	1,13	550								
				LS - ★ 1040	0,64	380								
	42AM--/42AMA-	50H/50-		HS - Δ 1391	1,51	770								
				LS - ★ 1176	0,9	520								
	42AM--/42AMA-	63H/63-		HS - Δ 1000	1,3	590								
				LS - ★ 750	0,63	250								
HEATING	42AMS-	63H		HS - Δ 1000	1,3	590	54	YES 6.3 A - 165 °C	F	-40 °C / +70 °C				
				LS - ★ 750	0,63	250								
	42AM--	35H	SINGLE-PHASE 230 V - 50 Hz	Direct 1330	0,7	150					44	NO	F	-40°C / +60°C
	42AM--/42AMA-	40H/40-		Direct 1400	1,3	300								
	42AM--/42AMA-	45H/45-		Direct 1380	2,01	480								
42AM--/42AMA-	50H/50-	Direct 1403		2,78	630									
42AM--/42AMA-	63H/63-	Direct 913		2,6	580									
EC FMA														
HEATING	42AM--	30H	SINGLE-PHASE 230 V 50/60 Hz	1530	0,8	85	54	PTC	B	-25 °C/+55 °C				
	42AM--	35H		1480	1,35	165								
	42AM--/42AMA-	40H/40-		1760	2,2	500					55	Thermal cut-out	B	-25°C/+60°C
	42AM--/42AMA-	45H/45-		1500	2,2	500					55	Thermal cut-out	B	-25°C/+60°C
	42AM--/42AMA-	50H/50-		1440	3,25	740					55	Thermal cut-out	B	-40°C/+60°C
	42AM--/42AMA-	63H/63-		1020	3,2	730					55	Thermal cut-out	B	-40°C/+60°C
COOLING	42AM--	30C	SINGLE-PHASE 230 V 50/60 Hz	1530	0,8	85	54	PTC	B	-25 °C/+55 °C				
	42AM--	35C		1040	0,65	73					54	PTC	B	-25°C/+60°C
	42AM--	40C		1760	2,2	500					55	Thermal cut-out	B	-25°C/+60°C
	42AM--	45C		1500	2,2	500					55	Thermal cut-out	B	-25°C/+60°C
	42AM--	50C		970	1,1	250					55	Thermal cut-out	B	-25°C/+60°C
	42AM--	63C		770	1,1	250					55	Thermal cut-out	B	-25°C/+60°C

## COIL SPECIFICATIONS

		30	35		40		45		50		63	
HOT WATER/COLD WATER COIL	Number of heating rows	2	1	3	1	3	1	3	1	3	1	3
	Number of cooling rows	2	3									
	Coil capacity (L)	0,8	0,68	1,66	0,96	2,28	1,38	3,22	2,18	4,55	2,97	6,4
	Connection diameter	1/2"	3/4"				1"		1" 1/4			
	Connection type	Threaded unions 243 GCU F/M										
	Maximum operating pressure	13 bar										
	Test pressure	24 bar										
Max T°	110°C											
SUPERHEATED WATER COIL	Number of heating rows	1										
	Coil capacity (L)		1,19		1,69		-		2,66		3,69	
	Connection diameter		33,7 mm		42,4 mm		-		42,4 mm			
	Connection type	Smooth 316L stainless steel tube (to be welded)										
	Maximum operating pressure	16 bar										
	Test pressure	24 bar										
Max T°	200°C											
STEAM COIL	Number of heating rows	1										
	Coil capacity (L)		0,97		1,22		-		1,95		2,86	
	Connection diameter		26,9		33,7		-		48,3			
	Connection type	Smooth 316L stainless steel tube (to be welded)										
	Maximum operating pressure	16 bar										
	Test pressure	24 bar										
Max T°	200°C											

## DIMENSIONS

### 42AM air heater

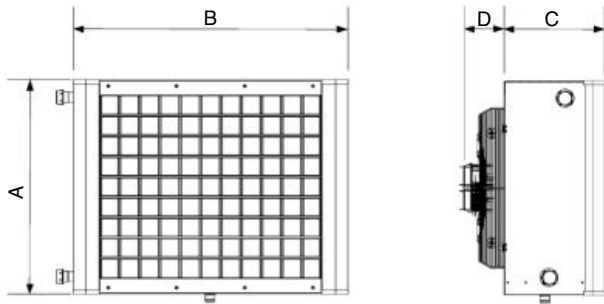

Size	A	B	C	D		Weight (kg)		
				STD	EC	1 row	2 rows	3 rows
	mm							
30	395	600	286	115	115	-	18	-
35	460	646	286	101	126	21	-	26
40	557	700	286	142	143	30	-	34
45	620	813	286	142	143	40	-	44
50	716	918	336	142	188	50	-	56
63	876	1050	336	142	200	62	-	72
63S	872	1050	295	126		60	-	-

### 42AMA destratifier

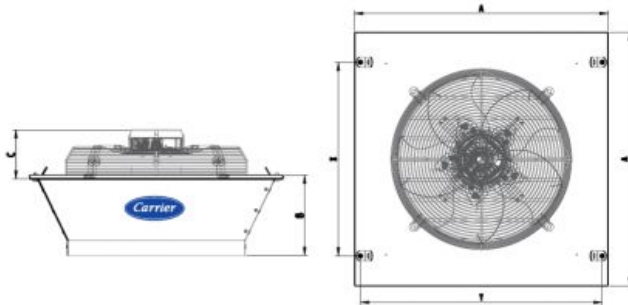

Size	A	B	C		X	Y	Weight kg
			STD	EC			
40	586	183	143	143	370	552	17
45	666	212	143	143	470	632	22
50	747	225	143	188	570	712	25
63	907	273	143	200	705	872	33

## INSTALLATION

### 42AM air heater

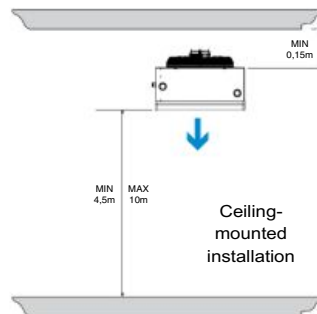
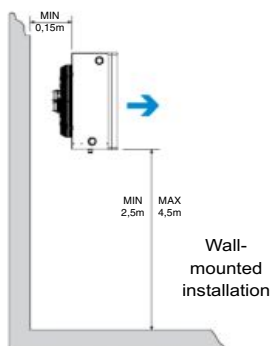

### 42AMA destratifier

Recommended for buildings between 5 and 15 metres high.

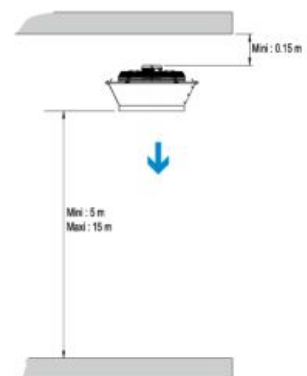





## ASSEMBLY ACCESSORIES

A different assembly for each use.



RETURN AIR ACCESSORIES						
	Size	A	B	C	Codes	<b>Filter box</b> (G1 filter in accordance with EN 779) Prevents premature clogging of exchanger coils Not ductable
	35	440		220	7185105	
	40	520			7185106	
	45	600			7185107	
	50	680			7185108	
63/63S	840		7185110			
DIFFUSION ACCESSORIES						
	Size	A	B	C	Codes	<b>Diffuser on door</b> Create an air curtain that limits energy loss when doors are opened.
	35	750	700	300	7185133	
	40	850	750	325	7185134	
	45	970	850	350	7185135	
	50	1100	970	375	7185136	
63/63S	1250	1170	400	7185137		
	Size	A	B	C	Codes	<b>Diffuser for large spaces</b> Reduction cone for increasing the air throws.
	35	–	–	–	–	
	40	178	555	522	7185138	
	45	136	637	618	7185139	
	50	132	740	714	7185140	
63/63S	282	872	814	7185141		
ASSEMBLY SUPPORT ACCESSORIES						
	Size				Codes	<b>Wall bracket</b>
	All				7181226	
	35 to 45				7181228	
	Size				Codes	<b>Additional kit for fastening on an IPN</b>
	50 to 63/63S				7181230	
	Size				Codes	<b>Suspension support for ceiling mounting</b>
	All				7282116	

## ELECTRICAL ACCESSORIES



### ELECTRICAL & USER SAFETY

	Codes	<b>Padlockable proximity switch</b>			
	0596142	Available in a 1 or 2-speed version, this accessory must be placed at least 2 metres from any rotating part, to comply with French standard IT 246, Art. 4-7-3, and EC requirements.			
	0596147				
	<b>Use</b>	<b>Circuit breaker unit - FMA SINGLE-PHASE AC heating</b>	<b>Circuit breaker unit - FMA SINGLE-PHASE EC heating</b>	<b>Circuit breaker unit - FMA SINGLE-PHASE EC cooling</b>	<b>Circuit breaker unit THREE-PHASE AC</b>
	<b>42AM--30</b>		7252526	7252526	
	<b>42AM--35</b>	7252526	7252527	7252526	7252523
	<b>42AM--40</b>	7252527	7252528	7252528	7252525
	<b>42AM--45</b>	7252528	7252528	7252528	7252527
	<b>42AM--50</b>	7252529	7252529	7252527	72525227
	<b>42AM--63</b>	7252529	7252529	7252527	7252527
	<b>42AMS-63</b>				7252527
	<b>42AMA-40</b>	7252527	7252528		7252525
	<b>42AMA-45</b>	7252528	7252528		7252527
<b>42AMA-50</b>	7252529	7252529		7252527	
<b>42AMA-63</b>	7252529	7252529		7252527	

### THERMOSTATS

	Codes	<b>Manual/auto room thermostat - SINGLE-PHASE / SINGLE-PHASE EC installation</b>
	7486653	"3-speed EC thermostat kit (for EC SINGLE-PHASE FMA) - Heating and cooling with manual toggle switch - Inductive breaking capacity 3.53A"
	7486654	"1-speed AC thermostat kit (for AC SINGLE-PHASE FMA) - Heating and cooling with manual toggle switch - Inductive breaking capacity 3.53A"
	5201027	Summer or Winter thermostat - SINGLE-PHASE AC FMA
	Codes	<b>IP54 industrial environment thermostat - THREE-PHASE AC installation</b>
	7113335	Summer or Winter thermostat - 3-PH AC FMA - 1 Stage
	7113336	Summer or Winter thermostat - 3-PH AC FMA - 2 Stages

### SUPPLY AIR SPEED SELECTION

	Codes	<b>LS/HS switch</b>
	7169961	For 3-phase motor, selects two motor rotation speeds and stop.
	Codes	<b>Autotransformer with selector switch (3.5 A)</b>
	7166982	Used to obtain 5 supply air speeds by varying the voltage on the variable speed AC 1 single-phase motors.

## 42AM SINGLE-PHASE EC AIR HEATER CONTROL

Single-phase EC FMA + LP water application:

- The single-phase EC BOX can control:
  - 6 H4000 single-phase ECs
  - 6 TPL 4000 single-phase ECs
  - 3 H4000 single-phase ECs + 3 TPL single-phase ECs
  - 4 H4000 single-phase ECs + 2 TPL single-phase ECs

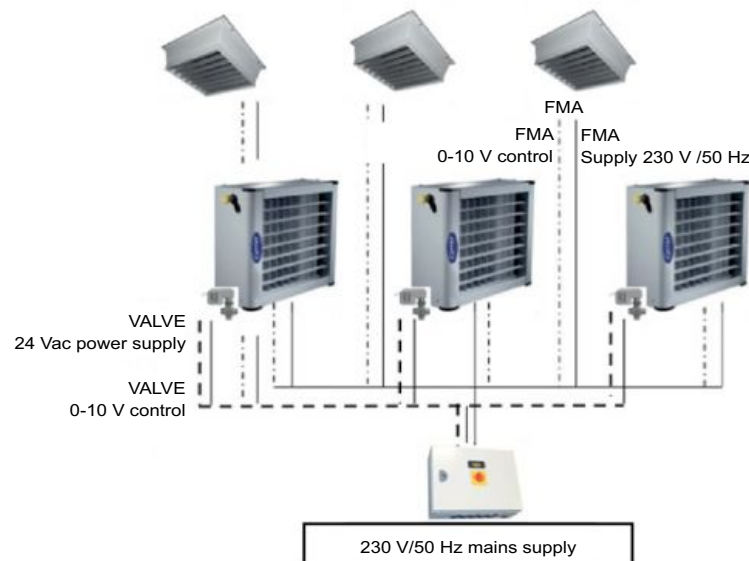

### Description

- Complete "PLUG & PLAY" control solution for air-source (0-10 V SINGLE-PHASE EC FMA) and/or water-source (0-10 V three-way valve) for 42AM air heaters equipped with SINGLE-PHASE EC FMAs.
- Proportional control system adjusts the supply air velocity and coil water supply based on the difference between the indoor temperature (measured by the built-in sensor) and the programmed temperature setpoint (summer or winter).
- Built-in timer featuring 3 operating modes: COMFORT, ECO and FROST PROTECTION (weekly setting).
- Electrical components (circuit breaker, padlockable proximity switch, contactor, thermostat, timer, etc.) included. Remote control On/Off function, with two fault summaries. Communication possible via ModBus/JBUS protocols or BACnet IP (optional expansion card).

### Advantages

- All your air heaters will be controlled centrally via an EC MONO BOX master controller
- You can adjust the heating or cooling to meet your needs as water is supplied to one or more heat exchangers in proportion to your building's heating demand (available with the optional valve kit).
- Supply air temperatures are controlled to maintain the necessary air streams. You can choose between fresh air only or mix with frost protection via the actuator to be installed on the 2-channel mixing box with built-in filter (available with the fresh air kit + damper actuator + frost protection thermostat kit) or 100% recirculated air.
- You will bring the fresh air rate of your building in line with current regulations or according to the space occupancy (via the built-in timer) thanks to an internal timer which can be configured on a weekly basis using 3 operating modes (Comfort, Eco, Frost protection). Fresh air damper controlled via the EC MONO BOX (On/off) depending on optional fresh air kit (Antifreeze thermostat + servomotor).
- Your building's heating requirement will depend on its occupancy and be serviced by centralised management of 42AM air heaters via the controller (a SINGLE-PHASE EC BOX controls 6 42AMs- or 6 42AMAs- or 3 42AMs- + 3 42AMAs- or 4 42AMs- + 2 42AMAs-).
- The display shows the operating status of each individual 42AM heater (fresh air or return air, motor fault, risk of frost, etc.)
- No need to size and wire the electrical components (circuit breaker, padlockable proximity switch, contactor, thermostat, timer, etc.) as this all-in-one control solution makes for faster installation.
- Two user levels: USER (restricted access) and INSTALLER (full access) for greater simplicity, ease of use and security.
- Option to use a remote control On/Off function with two fault summaries. Communication possible via ModBus/JBUS protocols or BACnet IP (optional expansion card).

### Electrical data

- Single-phase EC BOX unit supply: Single-phase 230 V
- Index of Protection: IP54
- Built-in motor overload and user protections as required by French standard NF C 15-100

## 42AM FOR EXPLOSIVE ATMOSPHERES

THE 42AM also meets the requirements of ATEX directives

Ex II 2 G  
II c 65 °C - 105 °C or 120 to 220 °C  
EEx d/de IIB or IIC T4 to T6

This special series of ATEX-certified 42AM air heaters is the result of CARRIER's extensive expertise and experience. This approval, issued by an independent external body, is your guarantee of complete compliance with the ATEX directives.

The 42AM-EX range is certified for your applications:

- In the presence of explosive gas agents
- In Zone 2 only
- For explosion groups IIB or IIC
- With T4 to T6 gas self-ignition temperatures
- Low pressure water, superheated water, steam, oil, compressed air...

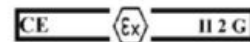

### What is ATEX?

ATEX or explosive atmosphere can be caused in atmospheric conditions by flammable gases, vapours or mists or by combustible dusts mixed with air. After ignition, combustion spreads through the whole of the unburned mixture.

### How is an ATEX zone defined?

ATEX zones are determined based on the probability and duration of the occurrence of an explosive atmosphere. This risk analysis is used to define zones, explosion groups and maximum surface temperature classes. These atmospheres are mainly found in painting workshops, metal processing workshops, waste recycling, wood processing, etc.

### Who defines ATEX zones?

Any operator of a production facility where an explosive atmosphere may occur must define the relevant ATEX zones, explosion groups and temperature classes. By doing so, the operator will also be able to set up the necessary means of prevention (communication, documentation, recommendations, etc.).

"Directive 94/9/EC divides the equipment and protective systems which it covers into equipment groups and categories; this Directive (1999/92/EC) provides for a classification by the employer of the places where explosive atmospheres may occur in terms of zones and determines which equipment and protective systems groups and categories should be used in each zone."

ZONE		Category	The explosive agent is:
Gas (G)	Dust (D)		
0	20	0	Present continuously, frequently or over a long period: NO CARRIER PRODUCT
1	21	1	Present occasionally under normal use: NO CARRIER PRODUCT
2	22	2	Rarely or briefly present

GAS - EXPLOSION GROUP AND TEMPERATURE CLASS						
Temperature class	T1	T2	T3	T4	T5	T6
Max surface temp	450°C	300°C	200°C	135°C	100°C	85°C
<b>Explosion group</b>						
<b>IIA</b>	Acetone Ammonia Benzene Acetic acid Ethane Ethyl acetate Ethyl chloride Methanol Naphthalene Phenol Propane	i-Amyl acetate Butane Butyl alcohol	Petrol Diesel Hot oil Hexane	Acetaldehyde		
<b>IIB</b>	Town gas	Ethylene	Hydrogen sulphide	Ethyl ether		
<b>IIC</b>	Hydrogen	Acetylene				Carbon disulphide

## OPERATING LIMITS

	Cooling mode	heating mode	Steam mode	Superheated water mode
<b>Water circuit</b>	Min. water inlet temp.: 5 °C Max. operating pressure: 13 bar	Max. water inlet temp.: 110 °C Max. operating pressure: 13 bar	Max. steam temp.: 200 °C Max. operating pressure: 16 bar	Max. water inlet temp.: 200 °C Max. operating pressure: 16 bar
<b>Indoor temperature</b>	Tmax: 60 °C and Tmin -15 °C			
<b>1-PH AC motor</b>	-	Nominal voltage: <b>230 V</b> (+/-6 %) Frequency: <b>50 Hz</b> <b>Size 35:</b> Index of Protection: <b>IP44</b> <b>Sizes: 40 - 45-50-63:</b> Index of Protection: <b>IP54</b>	Nominal voltage: <b>230 V</b> (+/-6 %) Frequency: <b>50 Hz</b> <b>Size 35:</b> Index of Protection: <b>IP44</b> <b>Sizes: 40 - 45-50-63:</b> Index of Protection: <b>IP54</b>	Nominal voltage: <b>230 V</b> (+/-6 %) Frequency: <b>50 Hz</b> <b>Size 35:</b> Index of Protection: <b>IP44</b> <b>Sizes: 40 - 45-50-63:</b> Index of Protection: <b>IP54</b>
<b>3-PH AC motor</b>	-	Nominal voltage: <b>400 V</b> (+/-6%) Frequency: <b>50 Hz</b> <b>Size 35:</b> Index of Protection: <b>IP44</b> <b>Sizes: 40 - 45-50-63:</b> Index of Protection: <b>IP54</b>	Nominal voltage: <b>400 V</b> (+/-6%) Frequency: <b>50 Hz</b> <b>Size 35:</b> Index of Protection: <b>IP44</b> <b>Sizes: 40 - 45-50-63:</b> Index of Protection: <b>IP54</b>	Nominal voltage: <b>400 V</b> (+/-6%) Frequency: <b>50 Hz</b> <b>Size 35:</b> Index of Protection: <b>IP44</b> <b>Sizes: 40 - 45-50-63:</b> Index of Protection: <b>IP54</b>
<b>SINGLE-PHASE EC motor</b>	"Frequency: <b>50/60 Hz</b> <b>Sizes 30 and 35:</b> Nominal voltage: 230 V (Range 200..240) Index of Protection: <b>IP54</b> <b>Sizes 40 - 45-50-63:</b> Nominal voltage: 230 V (Range 200..277) Index of Protection: <b>IP55</b>	Frequency: <b>50/60 Hz</b> <b>Sizes 30 and 35:</b> Nominal voltage: 230 V (Range 200..240) Index of Protection: <b>IP54</b> <b>Sizes 40 - 45-50-63:</b> Nominal voltage: 230 V (Range 200..277) Index of Protection: <b>IP55</b>	-	-





## EXTRA SLIM

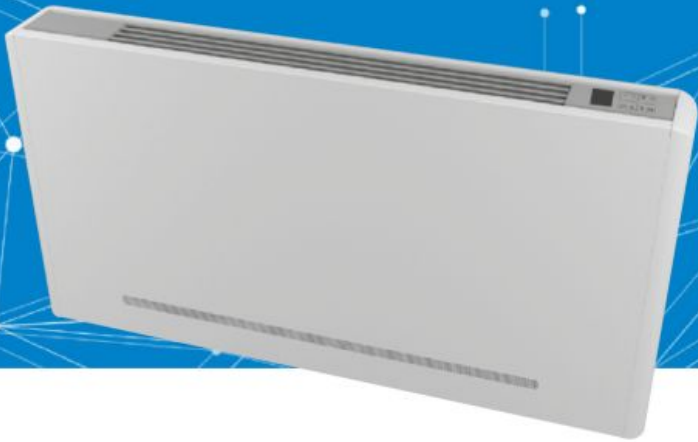

Extra slim  
(129 mm depth 370mm height)

Easy installation

Elegant design and reduced  
dimensions

Low energy consumption

Low noise level

## 42SI

Cooling capacity : 0.55 kW to 2.9 kW  
Heating capacity : 0.57 kW to 2.5 kW

The 42SI is an hydronic slim wall fan coil available in 4 models (with or without cabinet - standart or low height) and 5 sizes

The slim cabinet version can be installed in any ambient thanks to its elegant design and reduced dimensions (depth is only 129 mm).

All the models perform very low electric consumption and extremely quite sound levels according to the request of today's new projects.

The range consists of the following versions:

SIC - standard version with cabinet

SIR - compact version with cabinet

SIN - standard version without cabinet

SIL - compact version without cabinet



CARRIER participates in the ECP programme for FC-FCP  
Check ongoing validity of certificate:  
[www.eurovent-certification.com](http://www.eurovent-certification.com)

## RANGE

The 42SI range includes 4 models and 5 sizes .

It covers a range of cooling capacity from 0.55 kW to 2.9 kW at Eurovent conditions

The 42SI is available in :

- 2 pipe system heating or cooling
- 4 pipes system heating/cooling

## CODIFICATION

Range			Casing- Size& motor type				Coil Type	Control	Body Valve	Electrical heater	Actuators	Modification index
4	2	S	I	C	2	9	F	-	-	-	A	
1	2	3	4	5	6	7	8	9	10	11	12	13

Digit 12
' - = without
A = ON/OFF 230V ACTUATOR

Digit 11
- = without

Digit 10
' - = without
G = 2 WAYS VALVE GROUP
H = 3 WAYS VALVE GROUP

Digit 9
- = without
A = With Electronic control & user interface built-in
B = With Electronic control & command built-in with Wifi
C= With Electronic control (witout wall user interface)

Digit 8
F = 2 pipes Left
G = 2 pipes Right
C = 4 pipes Left
D = 4 pipes Right

Digit 5 - 6 - 7			
C	2	9	Size 2 _ Standard Height with cabinet_ EC motor
C	4	9	Size 4 _ Standard Height with cabinet_ EC motor
C	6	9	Size 6 _ Standard Height with cabinet_ EC motor
C	8	9	Size 8 _ Standard Height with cabinet_ EC motor
C	9	9	Size 9 _ Standard Height with cabinet_ EC motor
R	2	9	Size 2 _ Low Height (370 mm) with cabinet_ EC motor
R	4	9	Size 4 _ Low Height (370 mm) with cabinet_ EC motor
R	6	9	Size 6 _ Low Height (370 mm) with cabinet_ EC motor
R	8	9	Size 8 _ Low Height (370 mm) with cabinet_ EC motor
R	9	9	Size 9 _ Low Height (370 mm) with cabinet_ EC motor
N	2	9	Size 2 _ Standard Height without cabinet_ EC motor
N	4	9	Size 4 _ Standard Height without cabinet_ EC motor
N	6	9	Size 6 _ Standard Height without cabinet_ EC motor
N	8	9	Size 8 _ Standard Height without cabinet_ EC motor
N	9	9	Size 9 _ Standard Height without cabinet_ EC motor
L	2	9	Size 2 _ Low Height without cabinet_ EC motor
L	4	9	Size 4 _ Low Height without cabinet_ EC motor
L	6	9	Size 6 _ Low Height without cabinet_ EC motor
L	8	9	Size 8 _ Low Height without cabinet_ EC motor
L	9	9	Size 9 _ Low Height without cabinet_ EC motor

## TECHNICAL DESCRIPTION

### Frame

Made with high-resistance electrolytically zinc-coated metal.

### Casing (for 42SIC & 42SIR version)

Air intake grid made with electrolytically zinc-coated sheet metal painted with oven-dried epoxy powders, with quick-release device to clean the filters.

Reversible air outlet grid made with aluminium painted with oven-dried epoxy powders (metallic silver paint). Its generous size enhances its high mechanical strength

### For 42SIC 2 pipes :

Lateral made in plastic (RAL9003)

Front panel made with electrolytically zinc-coated sheet metal painted with oven-dried epoxy powders

### For 42SIC 4 pipes & 42SIR (low height) :

Sides and front panel made with electrolytically zinc-coated sheet metal painted with oven-dried epoxy powders (RAL 9003)

### Air Filter

Polypropylene filter, washable or regenerable.

### Fan Motor

Tangential fan made from synthetic material with staggered fins mounted on EPDM anti-vibration supports. Statically and dynamically balanced rotor, assembled directly on the motor's shaft.

Single phase electric motor fitted on anti-vibration EPDM supports.

### Heat exchange coil

It is made with copper pipes and aluminium fins with high efficiency coils . 3/4 Eurokonus threaded fittings compliant with the requirements of the new EU Standards.

### Condensate drip Tray

Made in ABS the outside diameter of the condensate discharge pipe is 14mm.

### Options fitted in factory

- 2 ways valve
- 3 ways valve
- ON/OFF 230V actuator
- electronic control with user interface built-in

### Accessories available in kit

- Kit 2 ways valve
- Kit 3 ways valve
- Back panel RAL9010 for cabinet version (42SIC or 42SIR)
- White color feet for covering floor pipes
- White color support feet
- In-wall box for vertical concealed version (42SIN or 42SIL)
- Front panel RAL90032 'equipped with return grill and supply adjustable blade for vertical concealed version (42SIN or 42SIL)
- LCD TOUCH electronic wall mounted control panel with or without WIFI module color black or white

## TECHNICAL DESCRIPTION

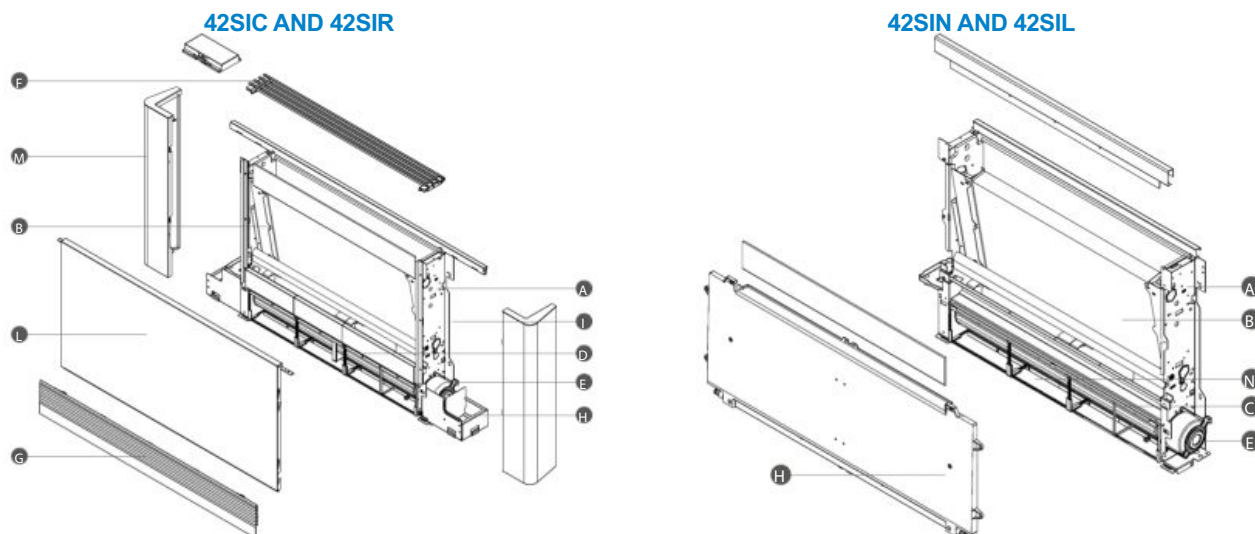

<b>A-I</b>	Supporting structure	Made of electro-galvanized sheet metal / compressed wire acoustic insulation.
<b>B</b>	Exchange battery	Manufactured from copper tubes and aluminum fins with high efficiency turbulence (turbine). Eurokonus 3/4 threaded connections, in accordance with the new EU standardization requirements. The coil is equipped with a water temperature sensor.
<b>C-D</b>	Fan motor assembly	Tangential fan in synthetic material with offset blades (very quiet operation) mounted on EPDM anti-vibration mounts. Statically and dynamically balanced rotor, directly splined to the motor shaft.
<b>E</b>	Electric motor	Single-phase unit mounted on EPDM anti-vibration supports.
<b>F</b>	Supply grid	Made of powder-coated aluminum (metallic silver color), kiln-dried. The generous size reinforces the high mechanical resistance.
<b>G</b>	Return grid	Made of electro-galvanized sheet metal painted with oven-dried epoxy powders (metallic silver or RAL 9010), with quick access for filter cleaning and safety microswitch.
<b>H</b>	Condensate pan	Condensate pan drip tray in impact-resistant ABS (for horizontal installation, SL/SLI versions optional).
<b>L</b>	Front panel	Made of electro-galvanized sheet metal painted with oven dried epoxy powder (metallic silver or RAL 9010).
<b>M</b>	Removable side panels	For inspection of the compartment, electrical or hydraulic connections.
<b>N</b>	Filter	Polypropylene honeycomb, dustable by washing or blowing. G1 class according to EN 779.
<b>O</b>	Condensate drain connection	To convey the condensate to a suitable location for drainage.



## DIMENSION, WEIGHT

With cabinet version : 42SIC 2 PIPES - 42SIC 4 PIPES - 42SIR 2 PIPES

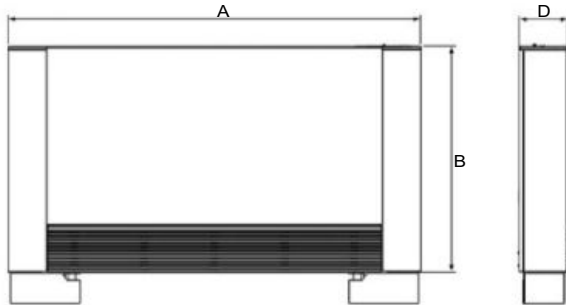

Without cabinet version : 42SIN 2-PIPE - 42SIN 4-PIPE - 42SIL 2 PIPE

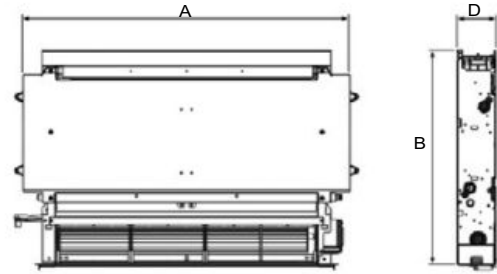

### 42SIC 2 PIPES

DIMENSIONS		42SIC29F/G	42SIC49F/G	42SIC69F/G	42SIC89F/G	42SIC99F/G
A	mm	735	935	1135	1335	1535
B	mm	579	579	579	579	579
D	mm	129	129	129	129	129
<b>WEIGHT</b>						
Net weight	kg	17	20	23	26	29

### 42SIC 4 PIPES

DIMENSIONS		42SIC29C/D	42SIC49C/D	42SIC69C/D	42SIC89C/D	42SIC99C/D
A	mm	737	937	1137	1337	1537
B	mm	639	639	639	639	639
D	mm	131	131	131	131	131
<b>WEIGHT</b>						
Net weight	kg	18	21	25	28	32

### 42SIR 2 PIPES

DIMENSIONS		42SIR29F/G	42SIR49F/G	42SIR69F/G	42SIR89F/G	42SIR99F/G
A	mm	735	935	1135	1335	1535
B	mm	379	379	379	379	379
D	mm	129	129	129	129	129
<b>WEIGHT</b>						
Net weight	kg	12	14	16	19	23

### 42SIN 2-PIPES

DIMENSIONS		42SIN29F/G	42SIN49F/G	42SIN69F/G	42SIN89F/G	42SIN99F/G
A	mm	525	725	925	1125	1325
B	mm	576	576	576	576	576
D	mm	126	126	126	126	126
<b>WEIGHT</b>						
Net weight	kg	9	12	15	18	21

## OPERATING LIMITS

Water Temperature min : 4°C

Water Tempertaure maxi : 80°C

Air ambient temperature min. : 5°C

Air ambient temperature maxi. : 32°C

## HYDRAULIC CONNECTIONS

### POSITION OF CONNECTION AND POSSIBLE INVERSION

The standard configuration of the machines has the hydraulic connections on the left and the control panels on the right.

If the positions must be inverted, the operation can be performed directly in factory on request.

The position of the hydraulic connections can be inverted from left to right during installation.

The choice and the dimension of the hydraulic lines are the responsibility of the designer, who must operate in accordance with good practice regulations and laws in force.

		29	49	69	89	99
<b>Distance</b>						
Water flow rate	l/h	215	390	525	700	890
Ø Steel	"	1/2	1/2	1/2	3/4	3/4
Ø Copper	mm	14	16	18	18	22
Ø Multilayer	mm	16	18	20	20	26

The condensate drain pan must be suitably sized (minimal internal pipe diameter of at least 16mm) and the pipework must be positioned so that always maintain a certain slope along the route (never less than 1%)

In vertical installation, the drain pipe is connected directly to the drainage tray positioned below the side panel, under the hydraulic connections.

## FLOW RATE - PRESSURE DROP CHARTS

### Key

- 1 29 model
- 2 49 model
- 3 69 model
- 4 89 model
- 5 99 model

### 42SIC - 42SIN

Cooling

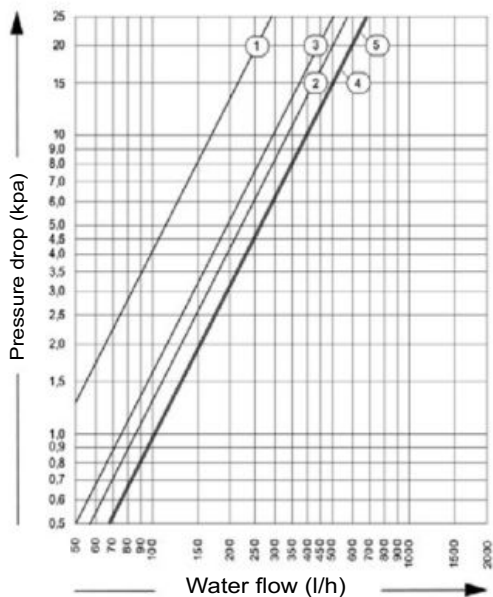

Heating

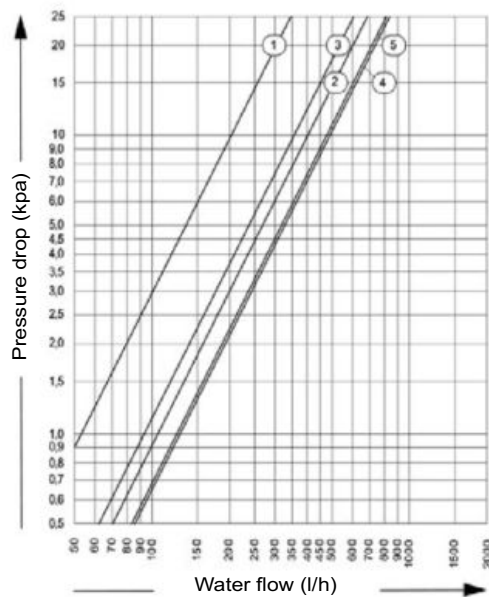

### 42SIR - 42SIL

Cooling

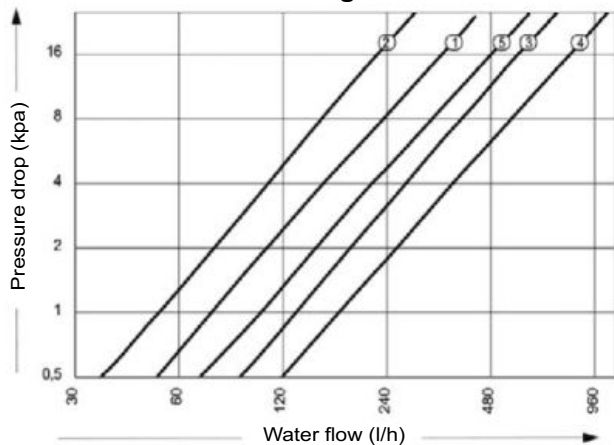

Heating

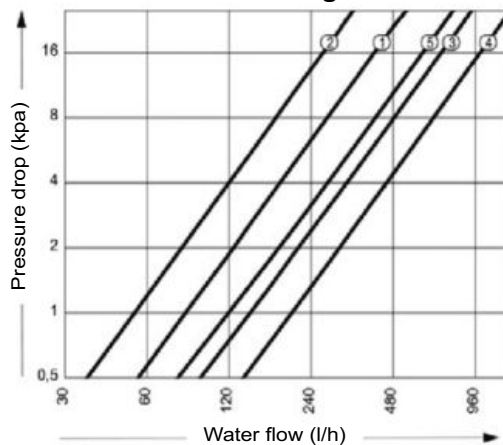

## THERMAL PERFORMANCES

### 2 PIPES

PERFORMANCE		42SIC29F/G 42SIN29F/G	42SIR29F/G 42SIL29F/G	42SIC49F/G 42SIN49F/G	42SIR49F/G 42SIL49F/G	42SIC69F/G 42SIN69F/G
Total cooling capacity	a kW	0,91	0,51	2,12	1,21	2,81
Sensible cooling capacity	a kW	0,73	0,43	1,72	1,01	2,11
Water flow rate	a L/h	157	88	365	208	483
Water pressure drop	a kPa	12,1	4,1	8,2	11,2	17,1
Heating capacity	b kW	1,02	0,61	2,21	1,51	3,02
Water flow rate	b L/h	175	105	380	260	519
Water pressure loss	b kPa	9,1	5,2	9,2	16,1	19,1
<b>HYDRAULIC FEATURES</b>						
Coil water content	L	0,47	0,28	0,8	0,5	1,13
Maximum operating pressure	bar	10	10	10	10	10
Hydraulic connections	EK	3/4				
<b>AERAUIC DATA</b>						
Maximum airflow	d m <sup>3</sup> /h	146	113	294	228	438
Airflow at medium speed (AUTO mode)"	m <sup>3</sup> /h	90	63	210	155	318
Airflow at minimum ventilation speed	m <sup>3</sup> /h	49	35	118	84	180
Maximum static pressure available	Pa	10	10	10	10	13
<b>ELECTRICAL DATA</b>						
Power supply voltage	V/ph/Hz	230/1/50				
Maximum electrical power consumption	W	11	11	19	19	20
Maximum current input	A	0,11	0,11	0,16	0,16	0,18
Abs. Electrical power at minimum speed	W	5	3	4	4	6
<b>SOUND LEVEL</b>						
Sound Power at maximum speed	db(A)	51	51	53	53	54
Sound pressure at maximum airflow	e db(A)	41	39	42	40	44
Sound pressure at average airflow	e db(A)	33	33	34	33	34
Sound pressure at minimum airflow	e db(A)	24	24	25	25	26

(a) Inlet water temperature 7°C, outlet water temperature 12°C, ambient air temperature 27°C dry bulb and 19°C wet bulb (UNI EN 1397).

(b) Inlet water temperature 45°C, outlet water temperature 40°C, air temperature 20°C (UNI EN 1397 standard).

(c) Inlet water temperature 65°C, outlet water temperature 55°C, ambient air temperature 20°.

(d) Airflow measured with clean filters.

(e) Sound pressure measured at a distance of 1 metre according to ISO7779

## THERMAL PERFORMANCES

### 2 PIPES

PERFORMANCE		42SIR69F/G 42SIL69F/G	42SIC89F/G 42SIN89F/G	42SIR89F/G 42SIL89F/G	42SIC99F/G 42SIN99F/G	42SIR99F/G 42SIL99F/G
Total cooling capacity	a kW	1,62	3,30	2,12	3,71	2,60
Sensible cooling capacity	a kW	1,44	2,71	1,99	2,90	2,34
Water flow rate	a L/h	279	568	365	638	447
Water pressure drop	a kPa	5,1	18,0	5,3	21,2	7,2
Heating capacity	b kW	2,03	3,81	2,62	4,32	3,11
Water flow rate	b L/h	349	655	451	743	535
Water pressure loss	b kPa	7,3	21,2	8,1	23,3	10,2
<b>HYDRAULIC FEATURES</b>						
Coil water content	L	0,61	1,46	0,77	1,8	0,9
Maximum operating pressure	bar	10	10	10	10	10
Hydraulic connections	EK	3/4				
<b>AERAULIC DATA</b>						
Maximum airflow	d m <sup>3</sup> /h	331	567	440	663	489
Airflow at medium speed (AUTO mode)	m <sup>3</sup> /h	229	410	283	479	344
Airflow at minimum ventilation speed	m <sup>3</sup> /h	124	247	138	262	167
Maximum static pressure available	Pa	10	13	10	13	10
<b>ELECTRICAL DATA</b>						
Power supply voltage	V/ph/Hz	230/1/50				
Maximum electrical power consumption	W	20	29	29	33	33
Maximum current input	A	0,18	0,26	0,26	0,28	0,28
Abs. Electrical power at minimum speed	W	4	5	4	5	5
<b>SOUND LEVEL</b>						
Sound Power at maximum speed	dB(A)	54	55	55	57	57
Sound pressure at maximum airflow	e dB(A)	41	46	42	47	43
Sound pressure at average airflow	e dB(A)	34	35	34	38	36
Sound pressure at minimum airflow	e dB(A)	25	26	26	28	27

- (a) Inlet water temperature 7°C, outlet water temperature 12°C, ambient air temperature 27°C dry bulb and 19°C wet bulb (UNI EN 1397).  
 (b) Inlet water temperature 45°C, outlet water temperature 40°C, air temperature 20°C (UNI EN 1397 standard).  
 (c) Inlet water temperature 65°C, outlet water temperature 55°C, ambient air temperature 20°.  
 (d) Airflow measured with clean filters.  
 (e) Sound pressure measured at a distance of 1 metre according to ISO7779







## HIGH WALL FAN COIL



- Easy installation
- Modern & design
- Low energy consumption
- Low noise level

## 42WM

Cooling capacity 1.2-3.8 kW  
Heating capacity 1.3-4.3 kW

The 42WM is an hydronic high wall fan coil available in 2 models and 4 sizes

The modern and appealing design of the unit in RAL 9003 colour allows the use in any environment.

All the models perform very low electric consumption and extremely quite sound levels according to the request of today's new projects.



CARRIER participates in the ECP programme for FC-FCP  
Check ongoing validity of certificate:  
[www.eurovent-certification.com](http://www.eurovent-certification.com)

## GAMME

The 42WM range includes 2 models and 4 sizes .

It covers a range of cooling capacity from 1.2 kW to 3.8 kW at Eurovent conditions

The 42WM is available in :

- 2 pipe system heating or cooling
- 2 pipes and electrical heater cooling and/or heating + electrical heater

## CODIFICATION

RANGE	SIZE	MOTOR TYPE	COIL TYPE	CONTROL	BODY VALVE	ELECTRICAL HEATER	ACTUATORS	EVOLUTION INDEX
42WM	10	0	C	T	-	-	-	-

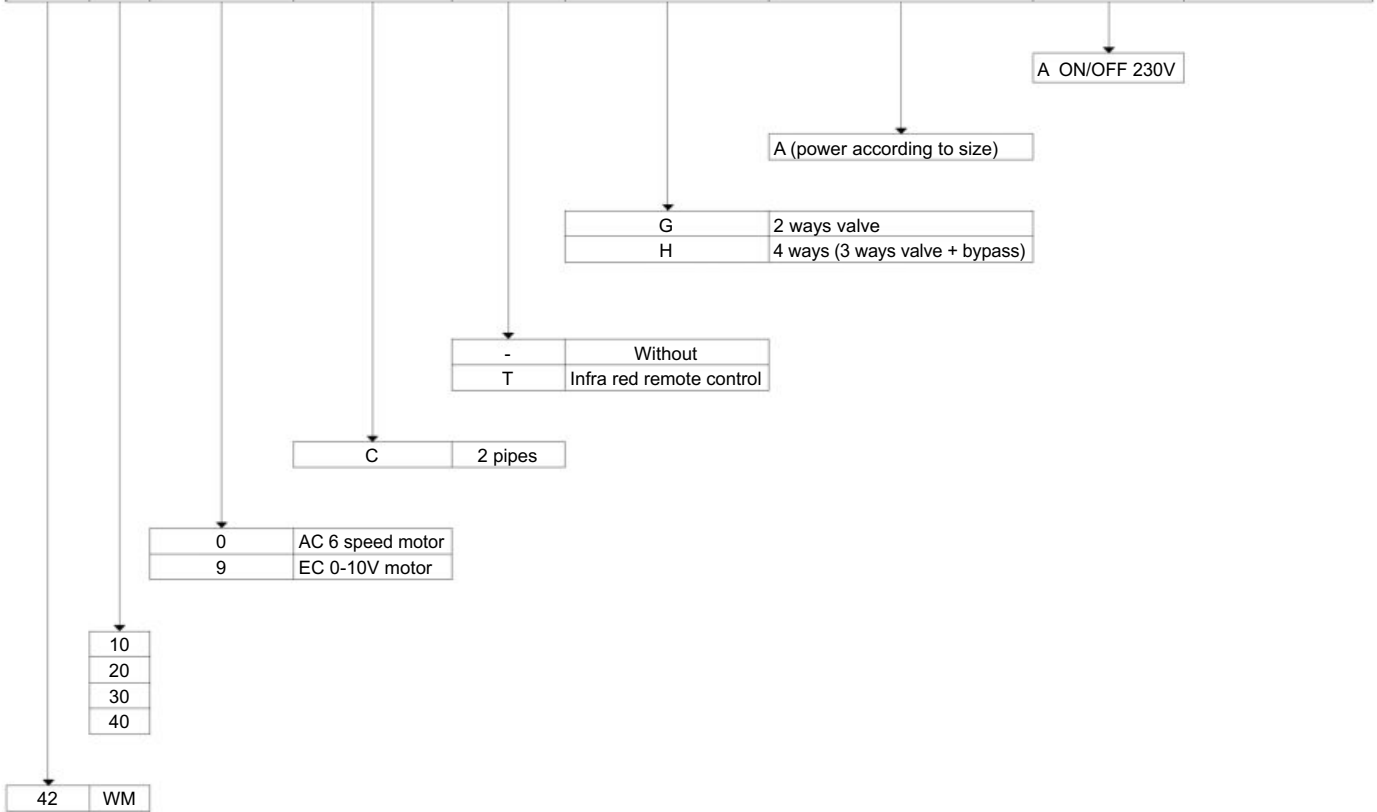

## TECHNICAL DESCRIPTION

### Casing

Made of auto-extinguishing ABS UL94 HB plastic with high specifications and great resistance to aging.  
The diffusion flap is adjusted manually in the basic version, with remote control in T version.

### Air Filter

Washable-regenerable synthetic filter, readily accessible.

### Fan Assembly

Made of plastic tangential fan.

### Electric motor

#### AC version

The motor is for single phase power supply and has six speeds, three of which are connected, with capacitor. The motor is fitted on sealed for life bearings and is secured on anti-vibration and self-lubricating mountings. Internal thermal protection with automatic reset, protection IP 20, class B. The speeds connected in the factory are indicated by "MIN, MED and MAX" in the following tables.

#### EC version

Electronic motor with permanent magnet brushless electronic motor that is controlled with reconstructed current according to a BLAC sinusoidal wave.

The inverter board that controls the motor operation is powered by 230 Volt, single-phase and, with a switching system, it generates a three-phases frequency modulated, wave form power supply.

The electric power supply required for the machine is therefore single-phase with voltage of 230-240V and frequency of 50- 60Hz.

### Heat exchange coil

It is manufactured from drawn copper tube and the aluminium fins are mechanically bonded onto the tube by an expansion process. The coil has two 1/2 inch BSP internal connections and 1/8 inch BSP air vent and drain.

The heat exchanger is not suitable for use in corrosive atmosphere or in environments where aluminium may be subject to corrosion.

The connections are on the left side facing the unit only.

### Electrical heater (option)

The heater is hermetically sealed and supplied inside the battery pipes and therefore can be only factory mounted.

The electric heaters are single phase 230V supply.

The electric heater is fitted with a overheat protection.

The unit is fitted with two safety thermostats:

- one thermostat with manual reset;
- one thermostat with automatic reset

### Condensate Collection Tray

Made from polypropylene; the outside diameter of the condensate discharge pipe is 16mm.

### Installation template

A cardboard installation template is supplied with every unit to help the mounting on the wall.

### Options fitted in factory

- 2 ways valve
- 3 ways valve
- ON/OFF 230V actuator
- control with infra-red remote

### Accessories available in kit

- Condensate drain pump
- Kit 2 ways valve
- Kit 3 ways valve

## DIMENSION, WEIGHT

PRESENTATION

COOLING

HEATING

AIR TREATMENT

CONTROLS

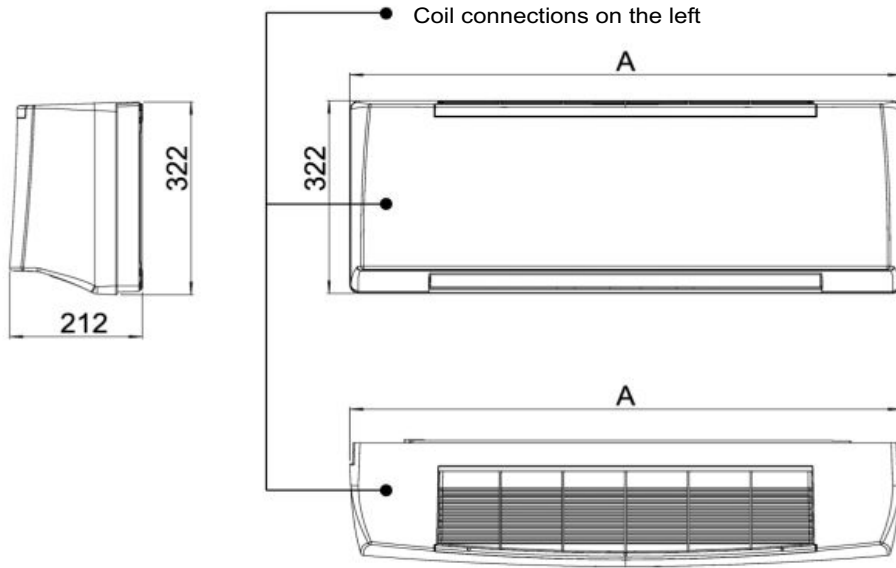

### Mounting Dimension

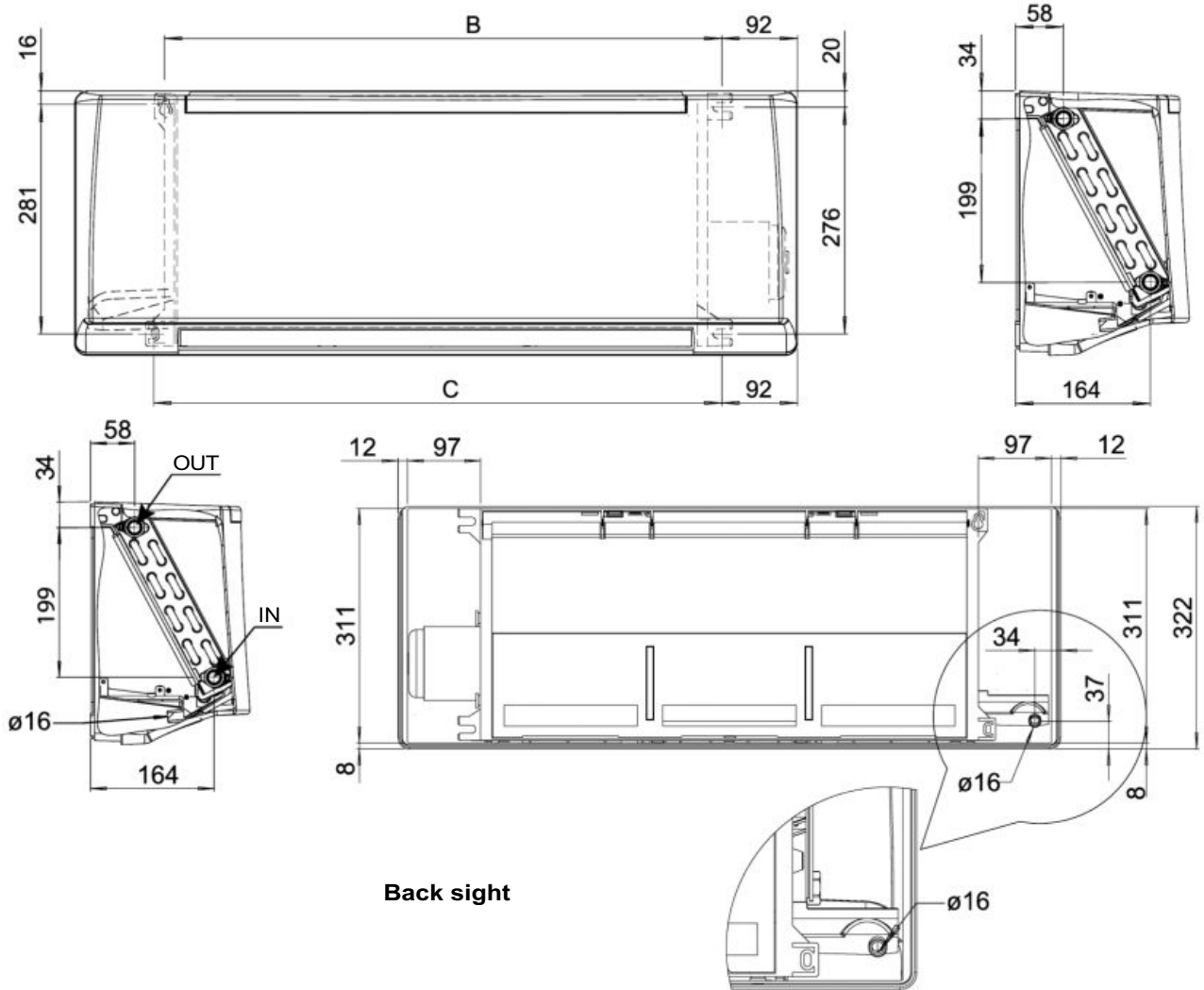



## DIMENSION, WEIGHT

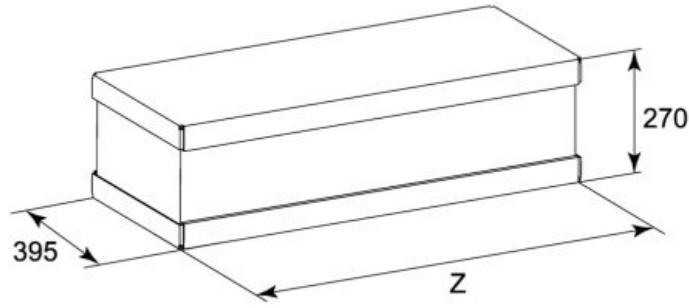

### Dimension (mm)

Model	10	20	30	40
A	880	880	1185	1185
B	678	678	983	983
C	691	691	996	996
Z	950	950	1255	1255

### Weight (kg)

Model	Weight packed unit				Weight unpacked unit			
	10	20	30	40	10	20	30	40
<b>without valve</b>	12	12	16	16	10	10	13	13
<b>with valve</b>	13	13	17	17	11	11	14	14

## TECHNICAL CHARACTERISTIC

Max. entering water temperature..... + 70 °C  
 Min. entering water temperature..... + 6 °C  
 for entering water temperatures below + 6°C, contact technical support  
 Max. rated pressure.....1000 kPa (10 bars)  
 Max. ambient temperature with electric coil in heating mode: 25°C.

### Water content (l)

Model	10	20	30	40
Liters	0,85	0,85	1,28	1,28

### Installation height (m)

Model	sizes 10 to 40
Minimum	2
Maximum	3

### AC motor electrical data (max. absorption)

Model		42WM100	42WM200	42WM300	42WM400
230/1 50Hz	W	30	32	46	48
	A	0,16	0,16	0,23	0,23

### EC Motor electrical data (max. absorption)

Model		42WM109	42WM209	42WM309	42WM409
230/1 50Hz	W	15	21	20	30
	A	0,14	0,19	0,18	0,26

### Electrical heater

Model	42WM100/109	42WM200/209	42WM300/309	42WM400/409
Nominal installed power	1000 Watt	1000 Watt	1500 Watt	1500 Watt
Nominal power voltage	230V ~	230V ~	230V ~	230V ~
Number and section of connecting wires	3 x 1,5mm <sup>2</sup>	3 x 1,5mm <sup>2</sup>	3 x 1,5mm <sup>2</sup>	3 x 1,5mm <sup>2</sup>
Current input	4,5 A	4,5 A	7 A	7 A
Recommended fuse (Type gG) for overload protection	6 A	6 A	8 A	8 A

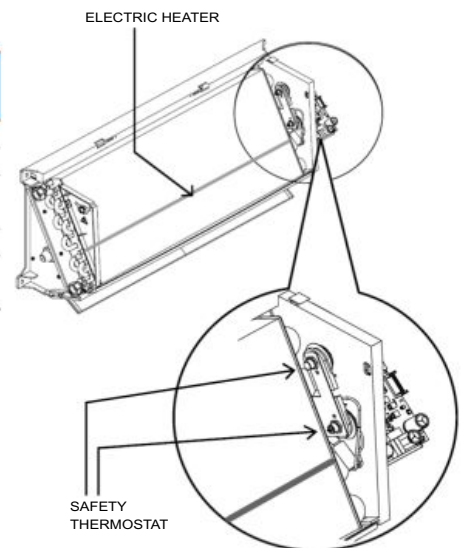

## EUROVENT PERFORMANCES

### 2-pipe units

Size	Speed	Air flow m³/h	Heating capacity W	Pressure Drop kPa	Cooling Capacity		Pressure Drop kPa	Pabs W	Lw dB(A)	LP * dB(A)	EUROVENT FCEER	EUROVENT FCCOP
					Total W	Sensible W					Class	Class
42WM100	1	205	1 340	4,5	1 230	910	4,8	12	35	26	C	C
	2	270	1 680	6,8	1 490	1 130	6,8	14	41	32		
	3	340	2 020	9,4	1 750	1 330	9,2	17	46	37		
	4	375	2 180	10,8	1 850	1 440	10,1	18	48	39		
	5	470	2 585	14,7	2 150	1 680	13,2	24	52	43		
	6	500	2 705	15,9	2 230	1 745	14,1	30	53	44		
42WM200	1	250	1580	6,1	1 420	1 060	6,2	12	39	30	C	C
	2	305	1850		1 640	1 230	8,0	14	43	34		
	3	365	2130	10,4	1 820	1 410	9,8	18	47	38		
	4	400	2290		1 953	1 495	11,1	20	49	40		
	5	480	2620	15,1	2 160	1 730	13,3	24	53	44		
	6	545	2880		2 350	1 855	15,5	30	55	46		
42WM300	1	280	1890	9,1	1 870	1 330	11,2	16	35	26	C	C
	2	375	1130	13,8	2 300	1 670	16,2	21	40	31		
	3	480	2930	20,1	2 770	2 030	22,7	26	45	36		
	4	545	3230	24,1	3 000	2 240	26,2	29	48	39		
	5	730	4040	35,9	3 630	2 755	37,1	38	55	46		
	6	780	4240	39,2	3 770	2 880	39,8	46	57	48		
42WM400	1	300	2 000	10,1	1 980	1 409	12,4	17	36	27	C	C
	2	440	2730	22,2	2 600	1 910	23,0	23	43	34		
	3	500	3020	28,2	2 845	2 090	30,3	27	46	37		
	4	610	3530	35,2	3 230	2 440	34,0	32	51	42		
	5	675	3800	39,9	3 460	2 610	40,4	35	54	45		
	6	790	4280	49,8	3 760	2 930	45,1	48	57	48		

Size	Speed (Voltage)	Air flow m³/h	Heating capacity W	Pressure Drop kPa	Cooling Capacity		Pressure Drop kPa	Pabs W	Lw dB(A)	LP *\$ (A)	EUROVENT FCEER	EUROVENT FCCOP
					Total W	Sensible W					Class	Class
42WM109	1V	190	1 260	4,0	1 160	850	5,0	6	37	28	B	B
	3V	240	1 530	5,7	1 390	1 025	6,0		39	30		
	5V	290	1 780	7,5	1 570	1 190	7,7	9	46	37		
	7,5V	355	2 090	10,0	1 810	1 370	9,6		48	39		
	10V	415	2 350	12,4	1 990	1 560	11,2	15	52	43		
42WM209	1V	260	1 630	6,4	1 460	1 090	6,9	7	40	31	B	B
	3V	315	1 900	8,4	1 680	1 260	8,3		44	35		
	5V	375	2 180	10,8	1 860	1 450	10,1	12	47	38		
	7,5V	440	2 460	13,4	2 070	1 600	12,3		51	42		
	10V	510	2 740	16,3	2 240	1 810	13,7	21	55	46		
42WM309	1V	270	1 830	8,7	1 820	1 300	10,7	6	37	28	A	A
	3V	345	2 240	12,5	2 200	1 580	14,9		42	33		
	5V	420	2 630	16,6	2 520	1 850	19,0	11	45	36		
	7,5V	420	3 110	11,5	2 930	2 160	25,1		49	40		
	10V	620	3 570	28,8	3 270	2 480	30,4	20	53	44		
42WM409	1V	375	2 400	14,1	2 330	1 690	16,5	9	43	34	A	A
	3V	465	2 850	19,3	2 720	1 990	21,9		46	37		
	5V	550	3 260	24,4	3 030	2 270	26,6	16	49	40		
	7,5V	665	3 760	31,7	3 430	2 590	33,4		53	44		
	10V	770	4 200	38,6	3 720	2 890	38,7	30	57	48		

**EUROVENT conditions**

Cooling mode : Entering air temperature : 27°C/19°C<sub>BH</sub>, entering/leaving water temperature : 7°C/12°C

Heating mode : Entering air temperature : 20°C, entering/leaving water temperature: 45°C/40°C

\* Acoustic pressure level is based on an hypothetical sound attenuation of the room of 9 dB(A)



Eurovent certified values

## ACCESSORIES

### Condensate drain pump

		Code
Not fitted on the unit		9025309
Height for vertical flow (m)	Water flow (l/h) depending on the length of horizontal flow	
	5m	10 m
1	7,6	7,2
2	5,6	5,2
3	4,0	3,7
4	3,2	2,9

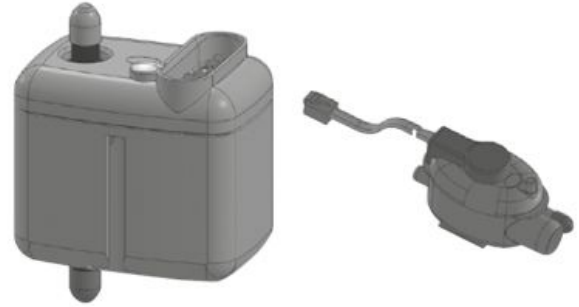

### Wall or concealed installation kit

Model	ID	Code
10-20	KIF 10-20	9025191
30-40	KIF 30-40	9025193

Wall or concealed installation kit to be used as an installation template or in case the right connections are previously designed (the units are provided only with left connections).

The technical space within the frame allows to unit the right connections of the installation and the left connections of the unit. Two variants are available:

- Recessed box installation
- Wall installation with aesthetic frame.

In the first case the frame is recessed, whereas in the second case it fits the unit esthetically.

The aesthetic frame characteristics are:

- Galvanized steel painted RAL 9003
- Pre-drilled panels for cables and ductworks
- Internal insulation.

#### Recessed box installation

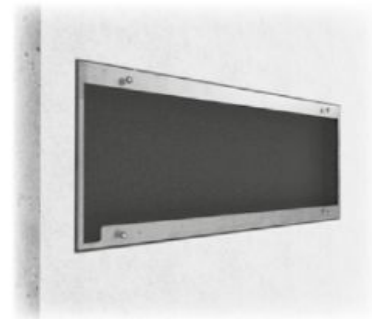

#### Wall installation

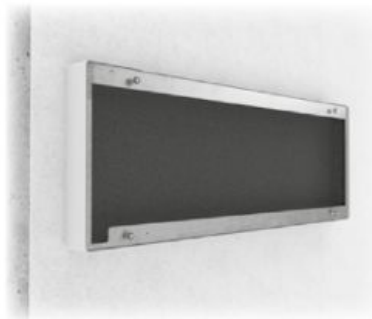

### Dimensions

Gr. 1 - 2

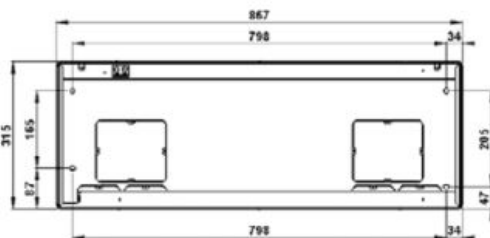

Gr. 3 - 4

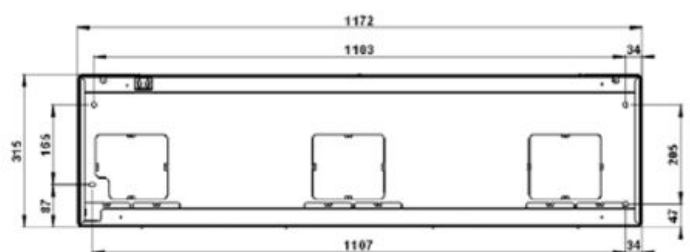

## ACCESSORIES

### 3 way valve

Mod.	Valve			Code
	DN	(Ø)	Kvs	Not fitted
10-20	15	1/2"	1,6	9025321H
30-40	20	3/4"	2,5	9025323H

### 2 way valve

Mod.	Valve			Code
	DN	(Ø)	Kvs	Not fitted
10-20	15	1/2"	1,6	9025311H
30-40	20	3/4"	2,5	9025313H

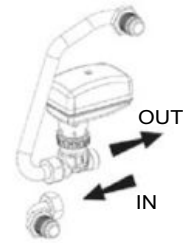
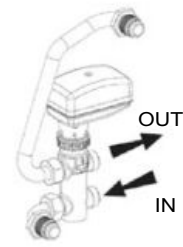







## DUCTABLE FAN COIL UNIT



Ductable unit for suspended ceiling or raised floor

Extra flat unit for better integration in renovation or new build projects

Optimised energy consumption level

Flexible configuration to meet the different requirements of buildings

Managed comfort

## 42EP



The Carrier 42EP range is available in 3 casing sizes with a 2-pipe coil, 2-pipe coil plus electric heater or 4-pipe coil. The total cooling capacity range is from 0.4 to 4.2 kW and the heating capacity range is 0.5 to 5 kW in the 2-pipe configuration and 0.5 to 4.8 kW with 4 pipes (Eurovent conditions)



CARRIER participates in the ECP programme for FC-FCP  
Check ongoing validity of certificate:  
[www.eurovent-certification.com](http://www.eurovent-certification.com)

## 1 - FUNCTIONS AND CONFIGURATIONS

- New generation slimline ductable fan coil (150 mm high) which can be adapted to both the new build and renovation markets to gain height underneath the suspended ceiling and improve the well-being of occupants.
- Equipped with an innovative fan combined with a low energy consumption (LEC) electronically commutated motor that meets the new building energy performance objectives thanks to auto-adaptive adjustment of the air flow rate from 0 to 100% ensuring perfect cooling and heating conditions in the room.
- G3 filter as standard.
- Safe factory installed electric heater with a wide choice of output levels.
- Low water pressure drop with factory installed valves.
- Factory-fitted options (valves and controllers) for fast and easy installation in suspended ceilings.
- The 42EP is available for fitting either in a suspended ceiling or a raised floor
- High operating pressure (above 150 Pa) with managed flow rate losses

### 1.1 - Configuration and flexibility

Each size of the 42EP can be supplied:

- with free return and/or direct air supply
- with a rectangular sleeve on the return and/or on the supply air
- with return plenums and/or supply air plenums to meet the requirements of installations with spigots with a diameter of 125 mm.

The illustration below shows the available plenum configurations with spigots with a diameter of 125 mm.

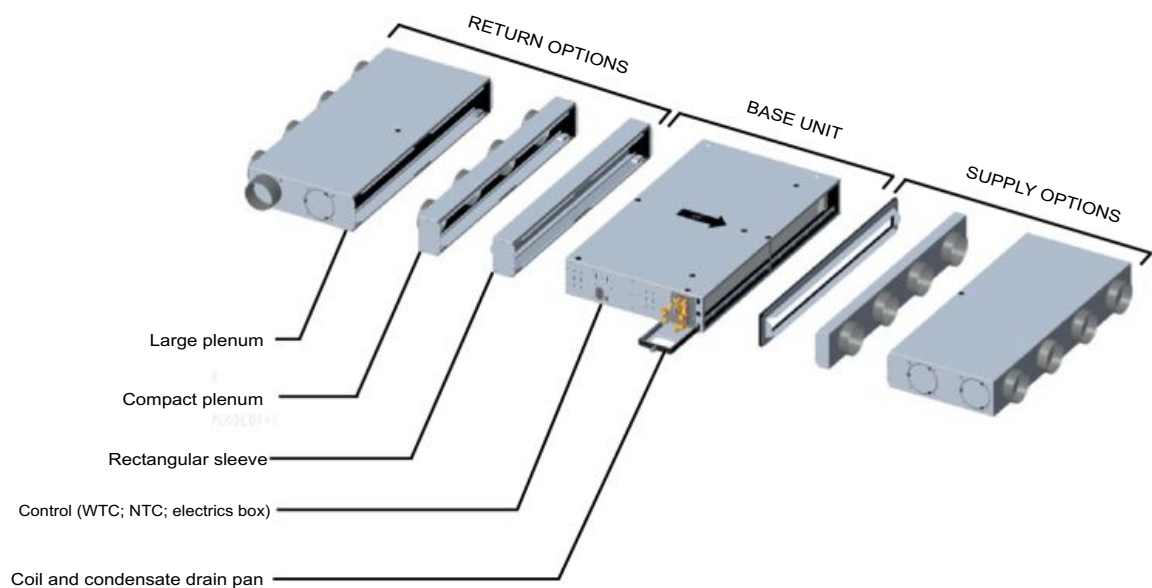

# 1 - FUNCTIONS AND CONFIGURATIONS

## 1.2 - Configuration with plenum with linear arrangement

Option of a Compact or Large plenum with spigots with a diameter of 125 mm  
 (\*) = Minimum number of spigots required to ensure sufficient available static pressure and fan reliability.

Ø125 mm	Number of spigots		
	42EP0xx	42EP1xx	42EP2xx
	2	3	4

### Large plenum with or without fresh air on the return

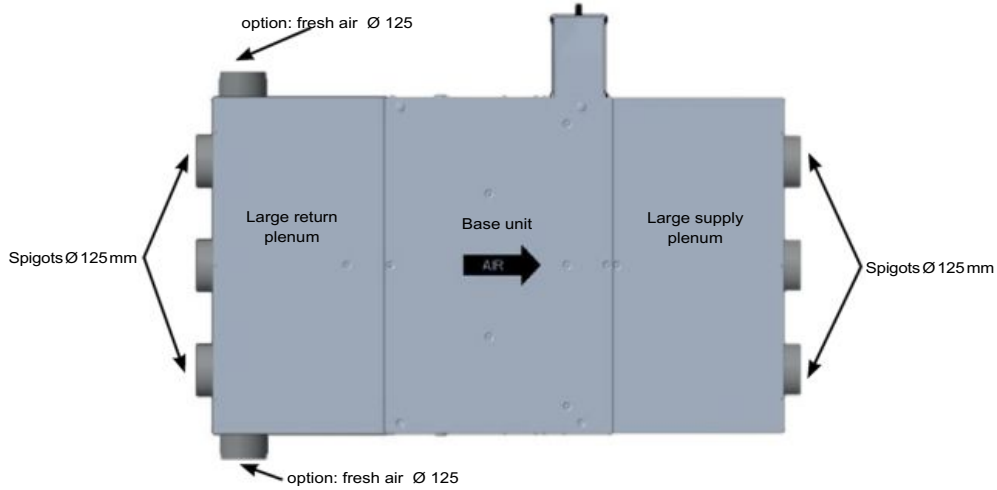

### Large plenum with or without fresh air on the supply air

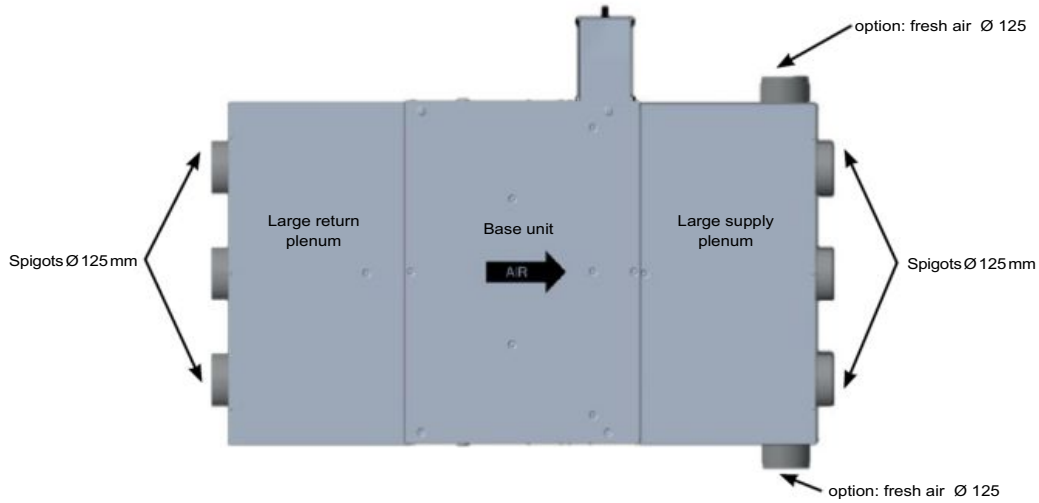

### Compact plenum (fresh air not available)

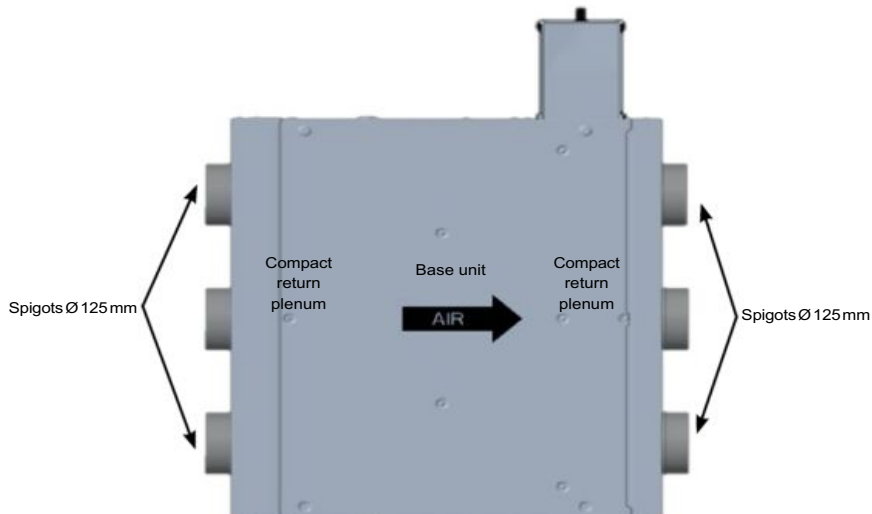

# 1 - FUNCTIONS AND CONFIGURATIONS

## 1.3 - Configurations with lateral plenum (U-shaped)

Ø125 mm	Number of spigots		
	42EP0xx	42EP1xx	42EP2xx
	2	2	2

### Large plenum with or without fresh air on the return

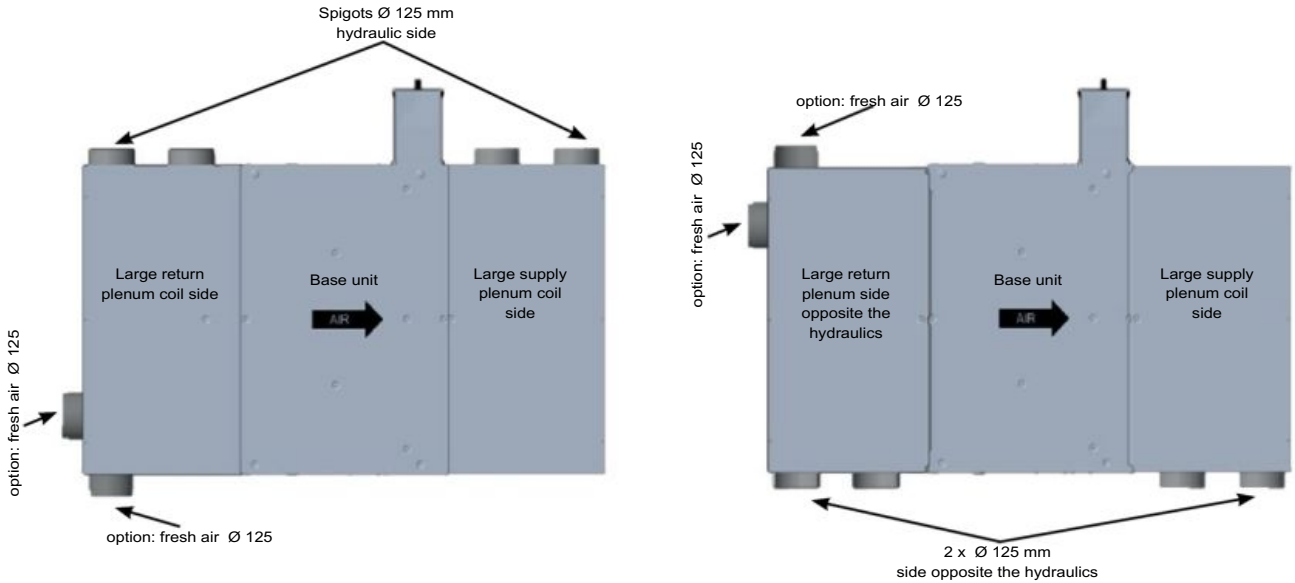

### Large plenum with or without fresh air on the supply air (Fresh air pressure available on the supply air must be greater than 200 Pa)

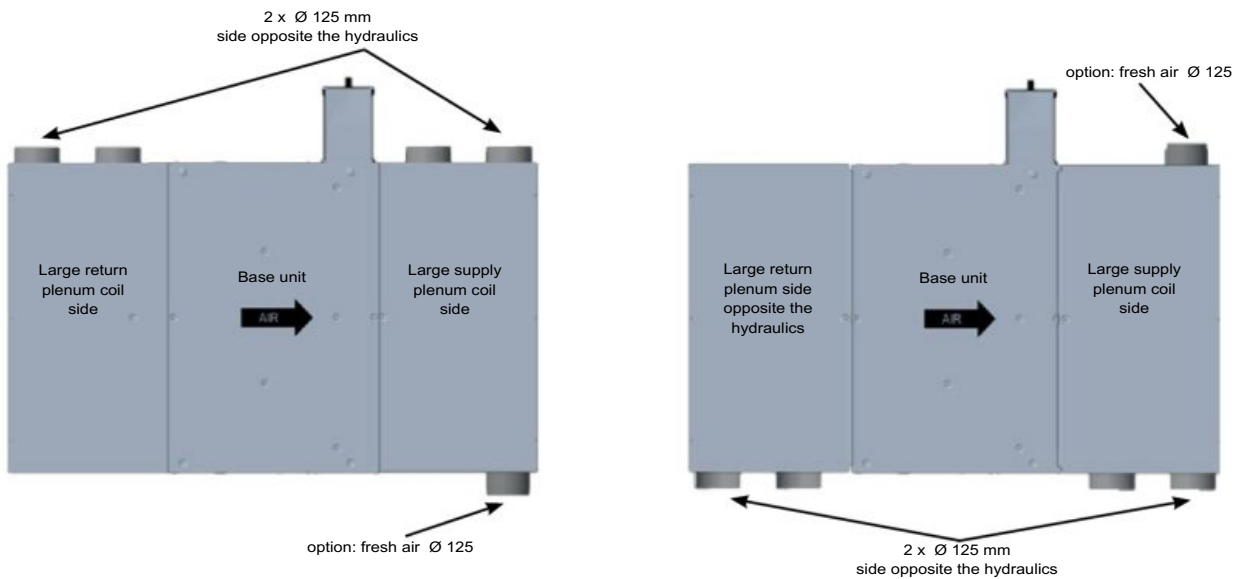



## 2 - DIMENSIONAL DRAWINGS

**NOTE:** All the plans shown are set up with the coil on the right; units set up with the coil on the left are strict symmetrical. The unit is shown in a suspended ceiling; it is available in a raised floor depending on the configuration (see type key on page 16)

### Standard unit with return and supply without rectangular sleeves fitted

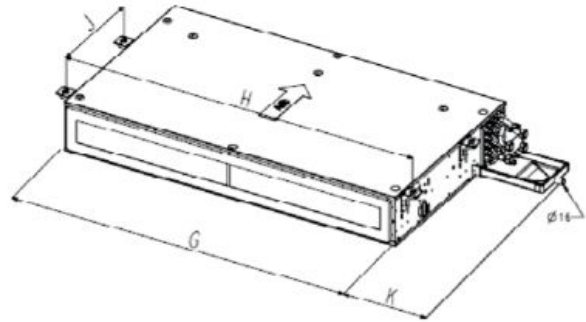
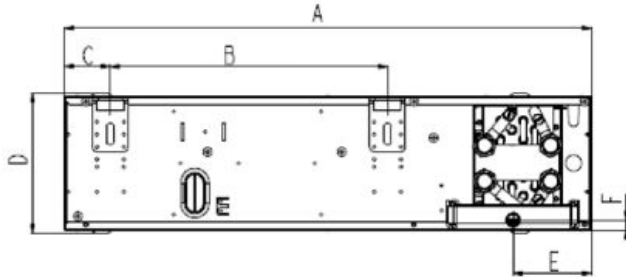

Dimensions in mm			
Size	0xx	1xx	2xx
A	589	589	589
B	310	310	310
C	51	51	51
D	156	156	156
E	87	87	87
F	15	15	15

Dimensions in mm			
Size	2xx	3xx	4xx
G	520	820	1020
H	569	869	1069
J	310	310	310
K	329	228	228
G + K	849	1048	1248
Weight* [kg]	12	16	21

### Standard unit with rectangular sleeves on the return and supply

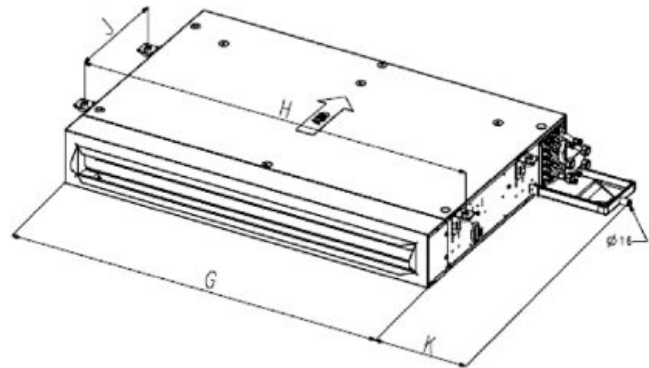
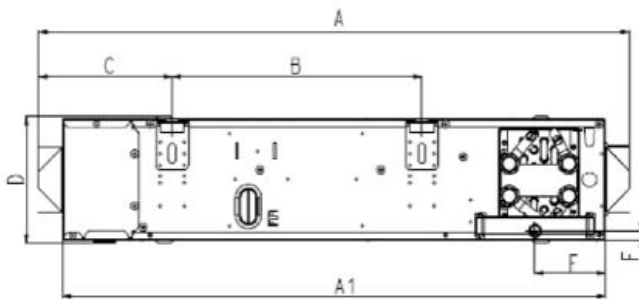

Dimensions in mm			
Size	0xx	1xx	2xx
A	733	733	733
B	310	310	310
C	165	165	165
D	156	156	156
E	87	87	87
F	15	15	15
Sleeves	451 x 81	751 x 81	951 x 81

Dimensions in mm			
Size	0xx	1xx	2xx
A1	674	674	674
G	520	820	1020
H	569	869	1069
J	310	310	310
K	329	228	228
G + K	849	1048	1248
Weight* [kg]	13	18	25

#### KEY

\* Maximum weight - without option - without water



Air flow direction

## 2 - DIMENSIONAL DRAWINGS

Standard unit with compact plenum with linear arrangement on the return and supply air (optimised length)

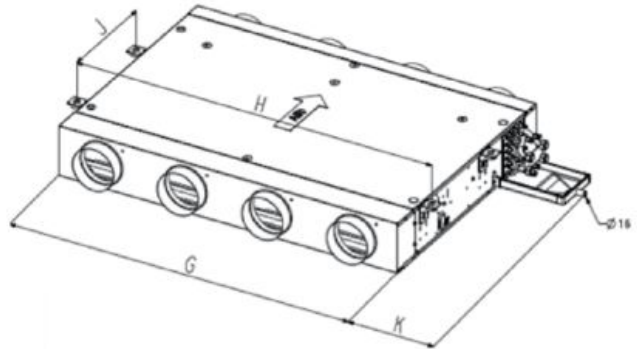
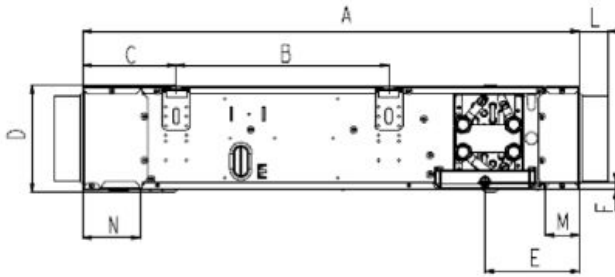

Dimensions in mm			
Size	0xx	1xx	2xx
A	724	724	724
B	310	310	310
C	136	136	136
D	156	156	156
E	138	138	138
F	15	15	15
M	50	50	50
N	83	83	83
L	42	42	42

Dimensions in mm			
Size	0xx	1xx	2xx
G	520	820	1020
H	569	869	1069
J	310	310	310
K	329	228	228
G + K	849	1048	1248
Weight* [kg]	15	21	28

Standard unit with large plenum with linear arrangement on the return and supply air

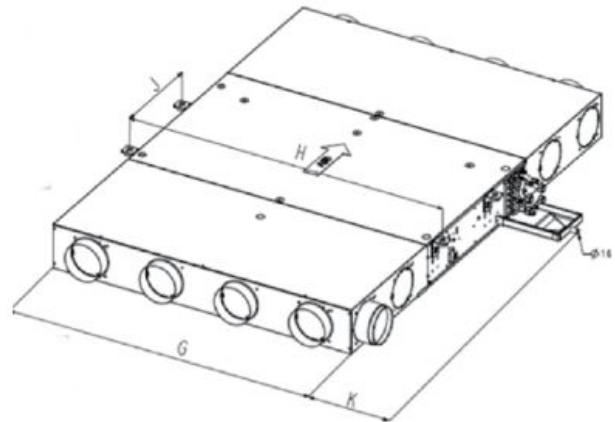
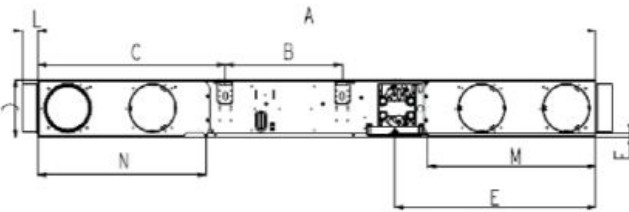

Dimensions in mm			
Size	0xx	1xx	2xx
A	1482	1482	1482
B	310	310	310
C	498	498	498
D	156	156	156
E	534	534	534
F	15	15	15
M	446	446	446
N	446	446	446
L	62	62	62

Dimensions in mm			
Size	0xx	1xx	2xx
G	520	820	1020
H	569	869	1069
J	310	310	310
K	329	228	228
G + K	849	1048	1248
Weight* [kg]	24	33	42

KEY  
 \* Maximum weight - without option - without water  
 Air flow direction

## 2 - DIMENSIONAL DRAWINGS

### Water coil

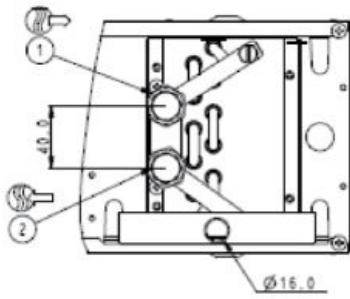

**2-pipe air coil** type 029 or 129 or 229

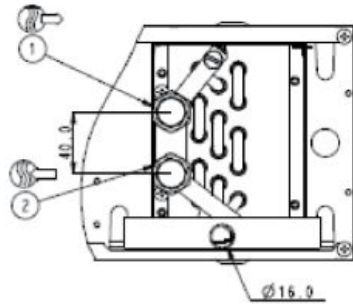

**2-pipe air coil** type 039 or 139 or 239

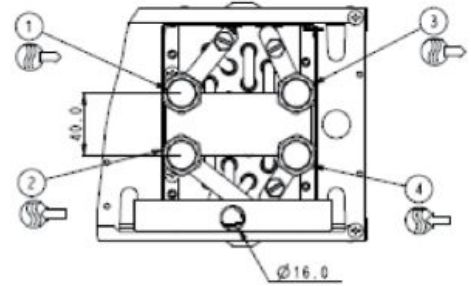

**4-pipe air coil** type 049 or 149 or 249

- 1 Cooling water outlet for 4-pipe coil and heating or cooling for 2-pipe coil
- 2 Cold water inlet for 4-pipe coil and hot or cold for 2-pipe coil
- 3 Heating water outlet for 4-pipe coil
- 4 Heating water inlet for 4-pipe coil

## 3 - MAIN MODULES AND COMPONENTS

### 3.1 - Casing

In order to further enhance occupant comfort, this product range offers especially low noise levels. The casing is made of galvanised sheet steel with full high-efficiency internal lining for optimised thermal and sound insulation of the unit.

In order to comply with the various local regulations (fire class) the fan-coil unit is available with both class M1 type insulation (according to NF P 92-507) and Euroclass level B-s3-d0 (according to EN 13501). It is also equipped with anti-vibration mounts as standard.

In order to reduce the dimensions to the minimum, the units are equipped with high-efficiency heat exchangers with very high cooling capacity/treated air flow ratios. The condensate drain pan height is optimised.

### 3.2 - Fan motor assemblies.

#### 3.2.1 - Low-consumption fan motor (variable-speed LEC motor)

##### Motor description

- Permanent magnet brushless motor
- Electronically commutated
- Class B winding insulation, varnish class F
- See operating limits in section 8

42EP units are equipped with LEC fan motors, controlled by a 0-10 V signal, which can be actuated by Carrier NTC or WTC controllers.

NOTE: In this case, the minimum control signal that allows the motor to start is 2 V for the two- and four-pipe versions; for versions equipped with electric heaters, please refer to section 9.

If the product is supplied without a Carrier control device, verification of EMC conformity is the responsibility of the installer.

### 3.3 - Fan wiring solutions

#### 3.3.1 - Unit with bare wires (standard)

The motor cable is left for the customer to connect up using its own resources.

The variable-speed low energy consumption (LEC) motor must be actuated by a 0-10 VDC signal.

#### 3.3.2 - Variable-speed low energy consumption (LEC) fan motor with electrics box

This option allows the installer to connect the unit directly to the electrical terminal strip installed in the electrics box. The electrics box can be opened with a screwdriver.

The 0-10 VDC signal that controls the variable-speed fan is directly accessible at the terminal strip.

#### 3.3.3 - Fuse holder or circuit breaker option

A fuse holder or a circuit breaker can be fitted to the units as an option.

### 3.4 - Hydraulic coil

- Aluminium fins mechanically bonded by expansion onto copper pipes
- 1/2-inch threaded female water inlet and outlet couplings
- Air bleed valves and drain valves as standard.
- Operating pressure 1600 kPa.

The coil, condensate drain pan and coil access door form a drawer which is easy to remove.

### 3.5 - Single unit condensate drain pan

As standard, the unit is equipped with a single unit condensate drain pan made from polypropylene and insulated with 5 mm of foam.

Drain connection diameter: Ø 16 mm external

HB fire rating (as per standard UL94).

As an option, the unit can be equipped with an aluminium pan insulated with 5 mm of foam.

This pan is compulsory if an electric heater is to be used

### 3.6 - Filter

#### 3.6.1 - Specifications

42EP units include a non-regenerative G3 filter as standard in compliance with EN 779.

The "without filter" option is only available for units with a plenum or a rectangular sleeve on the return side to ensure that a duct can be connected when the unit is operating.

To prevent fouling of the coil, Carrier recommends the use of a filter installed either in the fan coil unit or in the return air grille.

## 4 - OPTIONS SPECIFICATIONS

### 4.1 - Electric heater (option for 2-pipe coil)

Resistive wire type heater

- Supply voltage: 230 V - 1 ph - 50 Hz
- Heater size and capacity per unit (+5% ; -10%):

Electric heater capacity	Low	Medium	High	Very High
42EP 0x9	1 x 500 W	1 x 800 W	NA	NA
42EP 1x9	1 x 500 W	1 x 800 W	1 x 1000 W	NA
42EP 2x9	1 x 500 W	1 x 800 W	1 x 1000 W	1 x 1600 W

- The heater is protected with a dual safety device:
  - a) Self-holding automatically reset integrated safety thermostat
  - b) Destructive thermofuse link
- Available for 2-pipe coil only.

**WARNING: A minimum supply air flow rate must be maintained to avoid damaging the electric heaters.**

**A minimum control signal of 3 V is selected by default with the Carrier electronic controller (NTC / WTC).**

### 4.2 - Fresh air controller (option)

#### 4.2.1 - Constant volume fresh air controller

The coil can be fitted with a constant fresh air flow controller adjustable from 15 m<sup>3</sup>/h to 180 m<sup>3</sup>/h to allow the fresh air intake and the air change rate to be controlled.

The fresh air supply may be located in the supply plenum, or in the return plenum.

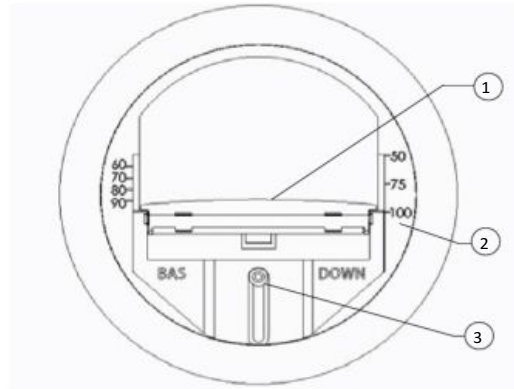

**Example: Range 50-100 m<sup>3</sup>/h**

- 1 Air Damper
- 2 Fresh airflow damper position setting (in m<sup>3</sup>/h)
- 3 Airflow adjustment screw

The fresh air controller may be modified on site by relocating the damper (adjustable screw). Three ranges of air-controller are provided: 15 to 50m<sup>3</sup>/h, 60 to 100m<sup>3</sup>/h and 110 to 180m<sup>3</sup>/h.

**IMPORTANT: If an optional return air temperature sensor is provided, the constant fresh air flow rate must not exceed 50 % of the unit supply air flow rate at minimum speed.**

**NOTE: To operate correctly, the fresh air flow controller requires a differential pressure in the range of 60 Pa to 210 Pa.**

#### 4.2.2 - Variable volume fresh air controller

The unit can be equipped with an optional variable fresh air flow controller from 0-55 l/s (0-200 m<sup>3</sup>/h). It is connected to the numeric Carrier controller and can regulate the fresh air intake in two ways:

- Either using a fixed rate set by the installer that can be reconfigured as required
- Or based on the CO<sub>2</sub> level; in this case it is connected to a CO<sub>2</sub> sensor via the Carrier numeric controller.



**NOTE: with the variable fresh air flow controller, the pressure upstream of the fresh air duct must be 180 Pa. The fresh air flow controller is not supplied fitted.**



## 4 - OPTIONS SPECIFICATIONS

### 4.3 - Valves and actuators

**NOTE:** The motor/valve assembly is normally closed.

#### 4.3.1 - Valve actuators

A wide choice of actuators is available with two- or four-way valve bodies (three-way with integral bypass) to offer the right solution for any controller type and customer requirement, from on/off to proportional types, with either 230 V or 24 V power supply:

- On/off 230 V actuator
- On/off 24 V actuator
- Floating 3-point 230 V actuator
- Floating 3-point 24 V actuator
- Modulating 0-10 V/24 V actuator

When combined with LEC motors and WTC or NTC controllers, floating 3-point 230 V actuators are recommended to increase energy savings and enhance comfort.

**NOTE:** 24 V power supply actuators are not compatible with Carrier controllers (Thermostats A/B/C/D, WTC and NTC).

#### 4.3.2 - Standard two-way valve body and three-way valve body (with integral bypass)

##### Specifications of 1/2" two-way and three-way valves

- 1/2" male BSP connection for union nuts
- Straight valve body with arrow indicating direction of flow embossed on valve body
- Nominal size DN15 for 1/2" valve
- Nominal pressure: PN 16 bar

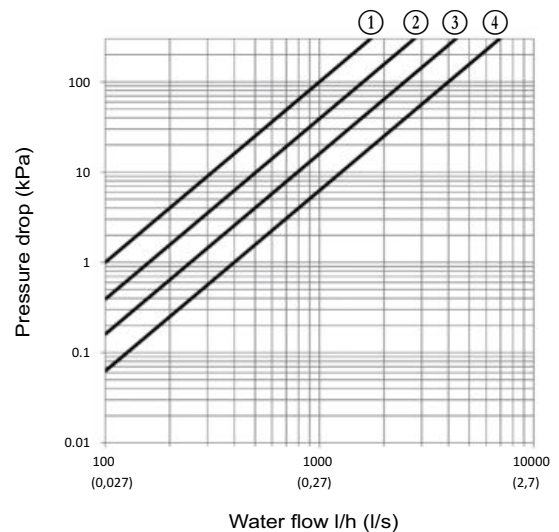
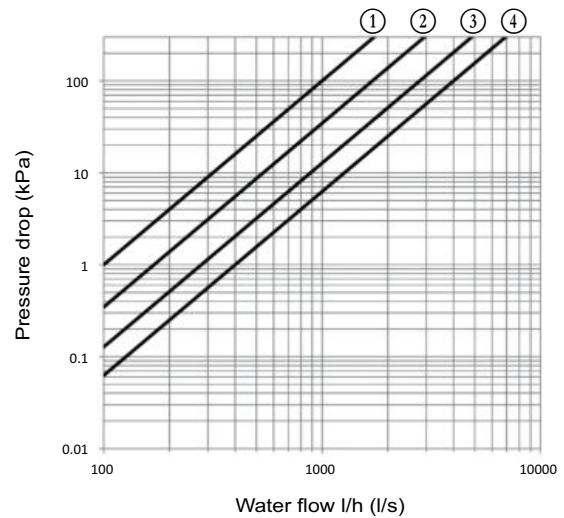

## 4 - OPTIONS SPECIFICATIONS

### 4.3.3 - Two way balancing valve body

Two-way valves with embedded balancing technology are available as an option. The CARRIER automatic balancing two-way valve combines the functionality of a dynamic balancing valve and a control valve in one product.



The dynamic balancing function maintains a constant differential pressure over the control valve.

The control valve regulates the flow by means of a variable orifice which is controlled by the actuator.

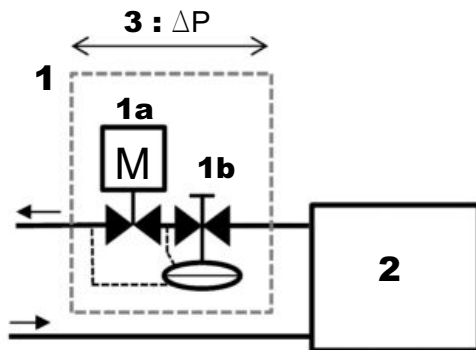

#### Key

1. Two-way valve with balancing function
  - 1a. Valve actuator for waterflow control
  - 1b. Differential pressure controller & balancing feature
2. Fan-coil unit
3. Minimum operating pressure drop at nominal waterflow: 20 kPa for sizes 4 and 5

The constant differential pressure across the control valve ensures accurate control and maximises valve authority, independently of the pressure conditions inside the system.

### Advantages compared to the two-way valve

- Improved and reliable commissioning. The water flow can be set and controlled on site.
- Higher energy efficiency due to optimal waterflow and maximized valve authority.
- Enhanced comfort thanks to stable and precise ambient temperature control.

### Specifications for automatic balancing 2-way valves

- 1" male BSP connection for union nuts
- Straight valve body with arrow indicating direction of flow embossed on valve body
- Nominal size DN 20 for 1" valve
- Nominal pressure: PN 16 bar
- Minimum operating differential pressure = 20 kPa at nominal flow.

## 4.4 - Water hoses (option)

### 4.4.1 - Materials

- Pipes: EPDM-based elastomer (Ethylene Propylene Diene Monomer)
- Braid: 304L stainless steel
- Insulation: cellular foam rubber with M1 fire rating (9 mm thick, flexible water pipes).

### 4.4.2 - Specifications

- Minimum bend radius (insulated pipes): 106 mm
- The water hoses are designed for treated or untreated water.
- Maximum operating pressure: 16 bar
- 1/2" female gas couplings with flat gaskets
- Length: 1 m.

## 4 - OPTIONS SPECIFICATIONS

### 4.5 - Sensors (option)

#### 4.5.1 - Water temperature sensor

A water temperature sensor can be provided as an option for NTC and WTC controllers.

- For 2-pipe coil: The sensor is installed on a cooling/heating water pipe (for change-over function).
- For 4-pipe coil: The sensor is installed on a heating water pipe (for cold-draft function that prevents the operation of the unit when the heating network is off).

While the fan coil unit is delivered with an electrical box, the "water temperature sensor" option is actually a switch that will be connected to the Carrier thermostat.

**NOTE:**

- *The water sensor option (switch) with electrical box is only available for 2-pipe coil without electric heater.*
- *A water probe can also be provided as an accessory only in order to use the cold draft function of the thermostat.*

#### 4.5.2 - Air temperature sensors

Two factory-fitted air temperature sensors are available as an option for NTC and WTC controllers. They measure the temperature at the supply and/or return side.

### 4.6 - Condensate pump (option)

The condensate pump option is designed to fit on the side of the unit drain pan. Electrical power supply 230V-50/60Hz.

Condensate pump discharge performances:

Discharge head	Water flow rate in litres per hour (-15% / +20%)			
	Horizontal length of the discharge pipe			
	5 metres	10 metres	20 metres	30 metres
1 metre	10,4	9,1	8,3	7,3
2 metres	8,8	7,8	7	6,4
3 metres	7,9	7,1	6,3	5,8
4 metres	7	6	5,3	4,9



Technical characteristics	
Max. flow rate	10,4 l/h
Max. discharge height	7 m (flow rate 4 l/h)
Maximum pressure	10 m (flow rate 0 l/h)
Sound level at 1 m as per EN ISO 3744 and 4871 (Measurement taken at LNE, pump in water, outside of application)	20,2 dBA
Electrical supply	230V +10%/-15% - 50/60Hz - 19W
Electrical insulation class	Class 1
Detection levels	ON: 14,7 mm, OFF: 10,7 mm, AL: 17 mm
Safety switch	BS: 5A resistive - 250V Contacts made from AgNI 90/10, gold-plated
Heat protection (overheating)	70°C (automatic restart)
Operating cycle (duty factor)	100%
Protection (as per BS EN 60529)	IP64
Safety standard	CE
RoHS directive	Compliant
WEEE directive	Compliant

## 5 - CONTROL

The unit can be supplied with a wide range of Carrier controls. These offer functions to suit the various application requirements, summarised in the table below.

	Thermostats	NTC	WTC
<b>Communication Protocols</b>			
Carrier Communication Network (CCN) Aquasmart compatible		x	
BACnet MSTP			x
LON			x
<b>Control algorithms</b>			
On-off	x		
Proportional-integral		x	x
Carrier Energy saving algorithm		x	x
<b>Fan control</b>			
AC motors 3 speeds descreet	Type A&B	x	x
Automatic optimum fan speed selection	x	x	x
EC motors 3 speeds descreet	Type C&D	x	x
EC motors Variable speed		x	x
<b>Water Valve management</b>			
Air flow control only (no water valve)	x		
230V On-off actuators	x	x	x
230V Modulating actuators (floating 3pts)		x	x
<b>Main functions</b>			
Setpoint control	x	x	x
Occupied/unoccupied mode	x	x	x
Frost protection mode	x	x	x
Window / Door contact input	x	x	x
Measurement of water inlet temperature for automatic seasonal changeover (2 pipes)	Type A&C	x	x
Measurement of water inlet temperature to prevent cold-draft (4 pipes and 2 pipes + electric heater)	Type B&D	x	x
Manual changeover	x	x	x
Frost protection mode	x	x	x
Continuous ventilation within dead-band	x	x	x
Periodical ventilation within dead-band	x	x	x
On-site configuration	x	x	x
Unit grouping Master/Slave	x	x	x
Cassette Louvers control		x	x
Supply air temperature monitoring limiting		x	x
Electric heater loadshed		x	x
Dirty filter alarm		x	x
Alarm reporting		x	x
Indoor Air Quality control (CO <sub>2</sub> sensor)		o	o
Demand control ventilation (DCV) (0-10V fresh air valve)		o	o
Free cooling mode			o
Presence detection			o
<b>User interfaces</b>			
Automatic or manual fan speed control	x	x	x
Setpoint adjustment	x	x	x
Occupancy (eco) button	x	x	o
Digital display		o	o
CO <sub>2</sub> sensor		o	o
<b>Control kit</b>			
On site control kit solution			o

**Key**

X Feature available as standard

O Optional

**NOTE:** for the features and specifications of the Carrier controllers outlined above, refer to the technical documentation for each controller.

Upon special request, other controller types can be factory-installed on the units (supplied by Carrier or the customer).

## 6 - LIST OF PRODUCT SPECIFICATIONS

Feature name	Digit no. type key	Value	Description	Compatibility
<b>Range</b>	1-2	42		
	3-4	EP		
<b>Chassis size</b>	5	0	Chassis size 0	
		1	Chassis size 1	
		2	Chassis size 2	
<b>Coil efficiency</b>	6	2	Standard	in 2-pipe only
		3	Medium	in 2-pipe only
		4	Medium	in 4-pipe only
<b>Motor type</b>	7	9	LEC low consumption motor	
<b>Connection and coil type</b>	8	F	2-pipe coil left-hand	connection: in the air flow direction
		G	2-pipe coil right-hand	
		C	4-pipe coil left-hand	
		D	4-pipe coil right-hand	
<b>Control</b>	9	-	Bare wires	
		E	Electrics box	
		K	NTC	
		L	WTC LON	
		M	WTC BACNET	
<b>Valve body</b>	10	-	Without valve	
		G	2-way valve	
		H	3-way valve with by-pass	
		L	Automatic balancing 2-way valve without pressure tappings	changeover sensor not compatible with two-way valve and automatic balancing 2-way valve
		T	Automatic balancing 2-way valve with pressure tappings	
<b>Electric heater</b>	11	-	Without electric heater	
		E	500 W electric heater	
		F	800 W electric heater	
		G	1000 W electric heater	Not available in Size 0
		H	1600 W electric heater	Not available in Size 0 & 1
<b>Valve actuator</b>	12	-	Without actuator	
		A	230 V ON/OFF actuator	
		C	3-point 230 V actuator	
		B	24 V ON/OFF actuator	not available with CARRIER control
		D	3-point 24 V actuator	not available with CARRIER control
		E	Modulating 0-10 V/24 V actuator	not available with CARRIER control
		P	Modulating PWM 230 V actuator	only for electrics box or WTC
<b>Return plenum</b>	13	-	Without	
		A	Rectangular sleeve	number of spigots according to size see sect.1.2
		B	Compact plenum	
		C	Large plenum (linear arrangement)	
		D	Large plenum (lateral arrangement) hydraulic side	
E	Large plenum (lateral arrangement) opposite the hydraulics			
<b>Supply plenum</b>	14	-	Without	
		A	Rectangular sleeve	number of spigots according to size see sect.1.2
		B	Compact plenum	
		C	Large plenum (linear arrangement)	
		D	Large plenum (lateral arrangement) hydraulic side	
E	Large plenum (lateral arrangement) opposite the hydraulics			
<b>Spigot diameter on the return</b>	15	-	Without	
		A	Ø 125 mm	
<b>Spigot diameter on the supply air</b>	16	-	Without	
		A	Ø 125 mm	

Key:



Basic configuration



## 6 - LIST OF PRODUCT SPECIFICATIONS

Feature name	Digit no. type key	Value	Description	Compatibility
<b>Filtration</b>	17	-	Without	compulsory plenum or sleeve on the return
		V	G3	
<b>Condensate pan</b>	18	P	Plastic	Compulsory with electric heater
		A	Aluminium	
<b>Fresh air</b>	19	-	Without	Only available with Large plenum
		A	DN125 spigot only	
		B	Module MR DN125 15-50 m <sup>3</sup> /h	
		C	Module MR DN125 50-100 m <sup>3</sup> /h	
		D	Module MR DN125 100-125 m <sup>3</sup> /h	
E	DN 125 adapter for fresh air valve (must be ordered separately)			
<b>Fresh air position</b>	20	-	Without	Only available with Large plenum
		A	On the return, hydraulic side	
		B	On the return, opposite the hydraulics	
		C	On the linear return	
		D	On the supply air, opposite the hydraulics	
F	On the supply air, hydraulic side			
<b>Relay for electric heater</b>	21	-	Without	Only for "electrics box" option
		R	with relay	
<b>Electrical protection</b>	22	-	Without	
		F	Fuse disconnect switch	
C	Circuit breaker			
<b>Air sensor</b>	23	-	Without	only for Control = NTC or WTC
		A	Return sensor	
		B	Supply air sensor	
C	Return air sensor & supply air sensor			
<b>Water temperature sensor</b>	24	-	Without	changeover sensor with four-way valve
		A	With water temperature sensor	
<b>Spigot protection</b>	25	-	Without	
		A	Hose protection	
<b>Hose</b>	26	-	Without	
		F	With hoses	
<b>Specific labelling</b>	27	-	Without specific labelling	
		A	Individual specific labelling	
		B	Specific labelling for the pallet	
C	Individual and pallet specific labelling			
<b>Application</b>	28	C	Suspended ceiling	
		F	Raised floor	

**Key:**
 Basic configuration

## 7 - 42EP PERFORMANCE DATA

### 7.1 - Physical and electrical data at Eurovent conditions - 42EP - Size 0

#### With G3 filter - without plenum

42EP 2-Pipe	029									039								
	2	3	4	5	6	7	8	9	2	3	4	5	6	7	8	9		
<b>Fan speed</b>	LS			MS			HS			LS			MS			HS		
Débit d'air m <sup>3</sup> /h	67	115	157	197	231	273	305	324	74	128	177	222	266	317	355	379		
Operating pressure Pa	9	27	50	78	107	150	187	211	6	17	32	50	72	102	128	146		
<b>Cooling mode, 2-pipe*</b>																		
Total cooling capacity kW	0,4	0,6	0,8	0,9	1,1	1,2	1,3	1,3	0,5	0,8	1,0	1,2	1,4	1,6	1,7	1,8		
Sensible cooling capacity kW	0,3	0,5	0,7	0,8	0,9	1,0	1,1	1,2	0,4	0,6	0,8	1,0	1,2	1,4	1,5	1,6		
Water flow rate l/h	71	106	136	161	181	203	217	222	87	137	178	214	245	278	300	310		
Water pressure drop kPa	1	3	5	6	8	10	12	12	1	2	3	5	6	8	10	11		
Water volume l	1,0									1,3								
<b>Heating mode, 2-pipe*</b>																		
Heating capacity kW	0,5	0,8	1,0	1,2	1,4	1,6	1,8	1,9	0,6	1,0	1,3	1,6	1,8	2,1	2,3	2,5		
Water flow rate l/h	91	136	176	212	241	277	304	322	103	165	219	268	312	363	400	426		
Water pressure drop kPa	2	4	6	8	9	11	13	14	1	3	4	6	7	9	11	12		
Water volume l																		
<b>Electric heater</b>	230V ±10% - 1ph - 50Hz									230V ±10% - 1ph - 50Hz								
Maximum capacity W	800									800								
Input current A	3,7									3,7								
<b>Low capacity</b>	500									500								
Input current A	2,3									2,3								
<b>Sound levels</b>																		
Supply air sound power level dB(A)	31	41	48	53	56	59	62	64	32	42	48	53	57	60	63	65		
Radiated+sound power level dB(A)	30	40	46	51	54	57	60	62	31	40	47	51	55	58	61	63		
<b>Motor electrical data</b>																		
Power input W	4	8	13	22	38	59	82	86	4	8	13	21	34	53	73	86		
Current A	0,043	0,063	0,094	0,147	0,223	0,335	0,447	0,553	0,043	0,063	0,094	0,147	0,223	0,335	0,447	0,553		
FCEER [energy class] 2-pipe	60	C							68	B								
FCCOP [energy class] 2-pipe	78	B							84	B								

Declared speeds: LS = Low Speed | MS = Medium Speed | HS = High Speed



Eurovent certified values

\* Eurovent conditions: Air inlet = 27 °C (19 °C wb) – water inlet = 7 °C, ΔT 5K

\*\* Eurovent conditions: Air inlet = 20 °C (15 °C wb max) – water inlet = 45 °C, ΔT 5K

\*\*\* Eurovent conditions: Air inlet = 20 °C (15 °C wb max) – water inlet = 65 °C, ΔT 10K

## 7 - 42EP PERFORMANCE DATA

42EP 4-Pipe		049							
Fan speed		2	3	4	5	6	7	8	9
		LS			MS		HS		
Air flow	m <sup>3</sup> /h	78	122	173	214	255	308	345	368
Operating pressure	Pa	7	16	33	50	72	104	131	148
<b>Cooling mode, 4-pipe*</b>									
Total cooling capacity	kW	0,5	0,8	1,0	1,2	1,4	1,6	1,7	1,8
Sensible cooling capacity	kW	0,4	0,6	0,8	1,0	1,1	1,3	1,5	1,6
Water flow rate	l/h	93	133	176	208	238	274	295	305
Water pressure drop	kPa	1	2	3	5	6	8	9	10
Water volume	l	1,3							
<b>Heating mode, 4-pipe***</b>									
Heating capacity	kW	0,8	1,1	1,3	1,5	1,7	2,0	2,2	2,3
Water flow rate	l/h	139	183	229	266	300	342	371	391
Water pressure drop	kPa	3	6	8	11	13	16	18	19
Water volume	l	0,5							
<b>Sound levels</b>									
Supply air sound power level	dB(A)	32	41	48	53	57	60	62	65
Intake+radiated sound power level	dB(A)	31	40	47	51	55	58	60	62
<b>Motor electrical data</b>									
Power input	W	4	8	13	22	38	59	82	86
Current	A	0,043	0,063	0,094	0,147	0,223	0,335	0,447	0,553
FCEER [energy class]	4-pipe	69	B						
FCCOP [energy class]	4-pipe	97	A						

Declared speeds: LS = Low Speed | MS = Medium Speed | HS = High Speed



Eurovent certified values

\* Eurovent conditions: Air inlet = 27 °C (19 °C wb) – water inlet = 7 °C, ΔT 5K

\*\* Eurovent conditions: Air inlet = 20 °C (15 °C wb max) – water inlet = 45 °C, ΔT 5K

\*\*\* Eurovent conditions: Air inlet = 20 °C (15 °C wb max) – water inlet = 65 °C, ΔT 10K

## 7 - 42EP PERFORMANCE DATA

### 7.2 - Physical and electrical data at Eurovent conditions - 42EP - Size 1

With G3 filter - without plenum

42EP 2-Pipe		129								139							
<b>Fan speed</b>		2	3	4	5	6	7	8	9	2	3	4	5	5,7	7	8	9
		LS		MS			HS			LS				MS	HS		
Air flow	m <sup>3</sup> /h	85	137	182	220	267	310	346	365	97	171	218	271	310	378	420	446
Operating pressure	Pa	11	28	50	73	108	145	180	202	5	15	25	38	50	74	92	104
<b>Cooling mode, 2-pipe*</b>																	
Total cooling capacity	kW	0,6	0,9	1,2	1,3	1,5	1,7	1,8	1,9	0,7	1,2	1,5	1,8	2,0	2,4	2,5	2,6
Sensible cooling capacity	kW	0,4	0,7	0,9	1,0	1,2	1,3	1,4	1,5	0,5	0,9	1,1	1,4	1,5	1,8	2,0	2,1
Water flow rate	l/h	120	180	230	260	310	350	380	390	128	212	261	313	346	406	436	452
Water pressure drop	kPa	4	9	14	18	23	28	32	34	3	7	11	15	19	24	28	30
Water volume	l	1,4								2,0							
<b>Heating mode, 2-pipe*</b>																	
Heating capacity	kW	0,7	1,0	1,3	1,5	1,8	2,0	2,2	2,3	0,8	1,3	1,7	2,0	2,3	2,7	3,0	3,1
Water flow rate	l/h	120	180	230	260	310	350	380	390	136	230	287	349	389	466	510	540
Water pressure drop	kPa	4	8	13	17	22	27	31	33	2	6	10	13	16	21	25	27
Water volume	l	1,4								2,0							
<b>Electric heater</b>		230V ±10% - 1ph - 50Hz								230V ±10% - 1ph - 50Hz							
Maximum capacity	W	1000								1000							
Input current	A	4,6								4,6							
<b>Medium capacity</b>		800								800							
Input current	A	3,7								3,7							
<b>Low capacity</b>		500								500							
Input current	A	2,3								2,3							
<b>Sound levels</b>																	
Supply air sound power level	dB(A)	32	43	50	55	59	62	65	67	33	43	50	55	58	63	65	68
Radiated+sound power level	dB(A)	33	41	48	52	57	60	63	64	30	42	47	52	55	60	62	64
<b>Motor electrical data</b>																	
Power input	W	5	8	16	25	39	60	80	88	5	8	16	25	39	60	80	88
Current	A	0,05	0,08	0,14	0,22	0,33	0,47	0,60	0,68	0,05	0,08	0,14	0,22	0,33	0,47	0,60	0,68
FCEER [energy class]	2-pipe	75	B							88	A						
FCCOP [energy class]	2-pipe	76	B							100	A						

Declared speeds: LS = Low Speed | MS = Medium Speed | HS = High Speed



Eurovent certified values

\* Eurovent conditions: Air inlet = 27 °C (19 °C wb) – water inlet = 7 °C, ΔT 5K

\*\* Eurovent conditions: Air inlet = 20 °C (15 °C wb max) – water inlet = 45 °C, ΔT 5K

\*\*\* Eurovent conditions: Air inlet = 20 °C (15 °C wb max) – water inlet = 65 °C, ΔT 10K

## 7 - 42EP PERFORMANCE DATA

42EP 4-Pipe		149							
Fan speed		2	3	4	5	5,8	7	8	9
		LS				MS	HS		
Air flow	m <sup>3</sup> /h	88	151	217	262	306	368	410	437
Operating pressure	Pa	4	12	25	37	50	73	90	102
<b>Cooling mode, 4-pipe*</b>									
Total cooling capacity	kW	0,7	1,1	1,5	1,8	2,0	2,3	2,5	2,6
Sensible cooling capacity	kW	0,5	0,8	1,1	1,3	1,5	1,8	2,0	2,1
Water flow rate	l/h	119	191	259	302	339	396	428	444
Water pressure drop	kPa	2	6	11	14	18	24	27	29
Water volume	l	1,4							
<b>Heating mode, 4-pipe***</b>									
Heating capacity	kW	1,0	1,5	1,9	2,2	2,4	2,7	2,9	3,1
Water flow rate	l/h	174	252	325	371	411	470	505	528
Water pressure drop	kPa	7	15	23	29	33	41	46	50
Water volume	l	0,7							
<b>Electric heater</b>		230V ±10% - 1ph - 50Hz							
Maximum capacity	W	1000							
Input current	A	4,6							
<b>Sound levels</b>									
Supply air sound power level	dB(A)	33	43	50	55	59	63	65	68
Intake+radiated sound power level	dB(A)	30	40	47	52	55	59	62	64
<b>Motor electrical data</b>									
Power input	W	5	8	16	25	39	60	80	88
Current	A	0,05	0,08	0,14	0,22	0,33	0,47	0,6	0,684
FCEER [energy class]	4-pipe	82	B						
FCCOP [energy class]	4-pipe	112	A						

Declared speeds: LS = Low Speed | MS = Medium Speed | HS = High Speed



Eurovent certified values

\* Eurovent conditions: Air inlet = 27 °C (19 °C wb) – water inlet = 7 °C, ΔT 5K

\*\* Eurovent conditions: Air inlet = 20 °C (15 °C wb max) – water inlet = 45 °C, ΔT 5K

\*\*\* Eurovent conditions: Air inlet = 20 °C (15 °C wb max) – water inlet = 65 °C, ΔT 10K



## 7 - 42EP PERFORMANCE DATA

### 7.3 - Physical and electrical data at Eurovent conditions - 42EP - Size 2

42EP 2-Pipe	229									239								
	2	3	4	4,8	6	7	8	9		2	3	4	5	6	7	8	9	
<b>Fan speed</b>	LS			MS		HS				LS			MS		HS			
Air flow m <sup>3</sup> /h	147	264	394	458	567	677	748	797		141	247	364	453	542	649	719	766	
Operating pressure Pa	5	17	37	50	77	109	134	152		5	15	32	50	72	103	127	144	
<b>Cooling mode, 2-pipe*</b>																		
Total cooling capacity kW	1,02	1,61	2,23	2,48	2,88	3,22	3,38	3,45		1,11	1,79	2,51	2,98	3,41	3,87	4,13	4,26	
Sensible cooling capacity kW	0,76	1,23	1,74	1,97	2,33	2,67	2,86	2,99		0,79	1,31	1,88	2,26	2,63	3,04	3,30	3,47	
Water flow rate l/h	176	277	382	426	494	553	581	593		190	306	431	511	586	664	709	731	
Water pressure drop kPa	14	34	68	87	106	118	127	127		7	19	34	45	57	71	81	87	
Water volume l	1,7									2,5								
<b>Heating mode, 2-pipe*</b>																		
Heating capacity kW	1,14	1,81	2,55	2,88	3,42	3,92	4,24	4,47		1,15	1,89	2,71	3,27	3,83	4,45	4,87	5,16	
Water flow rate l/h	196	312	439	495	589	676	730	770		198	326	467	564	659	766	838	889	
Water pressure drop kPa	12	29	51	62	81	103	117	127		6	15	27	38	49	63	73	80	
Water volume l	1,7									2,5								
<b>Electric heater</b>	230V ±10% - 1ph - 50Hz									230V ±10% - 1ph - 50Hz								
Maximum capacity W	1600									1600								
Input current A	7,3									7,3								
<b>High capacity</b>	1000									1000								
Input current A	4,6									4,6								
<b>Medium capacity</b>	800									800								
Input current A	3,7									3,7								
<b>Low capacity</b>	500									500								
Input current A	2,3									2,3								
<b>Sound levels</b>																		
Supply air sound power level dB(A)	36	45	52	56	60	63	66	68		37	46	52	57	61	64	66	69	
Radiated+sound power level dB(A)	33	43	49	53	58	61	64	66		33	43	49	54	58	61	64	66	
<b>Motor electrical data</b>																		
Power input W	9	14	26	38	63	96	133	167		9	14	26	38	63	96	133	167	
Current A	0,11	0,16	0,25	0,38	0,58	0,84	1,08	1,31		0,11	0,16	0,25	0,38	0,58	0,84	1,08	1,31	
FCEER [energy class] 2-pipe	71	B								78	B							
FCCOP [energy class] 2-pipe	83	B								85	A							

Declared speeds: LS = Low Speed | MS = Medium Speed | HS = High Speed



Eurovent certified values

\* Eurovent conditions: Air inlet = 27 °C (19 °C wb) – water inlet = 7 °C, ΔT 5K

\*\* Eurovent conditions: Air inlet = 20 °C (15 °C wb max) – water inlet = 45 °C, ΔT 5K

\*\*\* Eurovent conditions: Air inlet = 20 °C (15 °C wb max) – water inlet = 65 °C, ΔT 10K

## 7 - 42EP PERFORMANCE DATA

42EP 4-Pipe		249							
Fan speed		2	3	4	5	6	7	8	9
		LS			MS		HS		
Air flow	m <sup>3</sup> /h	139	247	351	451	532	632	702	755
Operating pressure	Pa	5	15	31	50	70	99	122	141
<b>Cooling mode, 4-pipe*</b>									
Total cooling capacity	kW	1,1	1,8	2,5	3,0	3,4	3,8	4,1	4,2
Sensible cooling capacity	kW	0,8	1,3	1,8	2,3	2,6	3,0	3,3	3,4
Water flow rate	l/h	191	316	421	516	583	658	702	729
Water pressure drop	kPa	7	19	32	45	55	69	78	86
Water volume	l	2,5							
<b>Heating mode, 4-pipe***</b>									
Heating capacity	kW	1,5	2,3	2,9	3,4	3,7	4,2	4,5	4,8
Water flow rate	l/h	260	393	495	579	641	723	780	825
Water pressure drop	kPa	19	39	58	76	90	111	125	136
Water volume	l	1,00							
<b>Sound levels</b>									
Supply air sound power level	dB(A)	37	46	52	57	61	64	66	69
Radiated+sound power level	dB(A)	33	42	49	54	58	61	64	66
<b>Motor electrical data</b>									
Power input	W	9	15	26	43	65	100	133	168
Current	A	0,11	0,16	0,25	0,38	0,58	0,84	1,083	1,308
FCEER [energy class]	4-pipe	78	B						
FCCOP [energy class]	4-pipe	98	A						

Declared speeds: LS = Low Speed | MS = Medium Speed | HS = High Speed



Eurovent certified values

\* Eurovent conditions: Air inlet = 27 °C (19 °C wb) – water inlet = 7 °C, ΔT 5K

\*\* Eurovent conditions: Air inlet = 20 °C (15 °C wb max) – water inlet = 45 °C, ΔT 5K

\*\*\* Eurovent conditions: Air inlet = 20 °C (15 °C wb max) – water inlet = 65 °C, ΔT 10K





Versatile unit meeting all building-specific constraints

Energy and ecodesign performance.

Improved occupant comfort, very low sound level

Innovative design ensuring easy installation and simplified maintenance

# 42N 42NC-42NR-42ND-42NI-42NU

Total cooling capacity 0,7– 8,7kW  
Nominal heating capacity 1,0– 9,15kW

Designed for heating and cooling, the new 42N is available in 2 models (cased or uncased).

The versatility of the new 42N, thanks to its different assembly options and range of accessories, means it can be adapted to any type of installation.

In Europe, it has become a benchmark solution for renovations of large office blocks and hotel chains and restoration of buildings, etc.

Modern aesthetic lines, excellent sound levels and optimised thermal performance. With its new 42N range, CARRIER offers a comfort solution which is both economical and quick to set up.



CARRIER participates in the ECP programme for LCP-HP  
Check ongoing validity of certificate:  
[www.eurovent-certification.com](http://www.eurovent-certification.com)

# MORPHO CODES

Range & Model				Size	Coil efficiency	motor type	Coil Type	Control	Valve	Electrical heater	Actuators	Supply Rect. flange	Sensors	Drain pump
4	2	N	C	1	2	9	F	A	G	A	A	-	-	-
1	2	3	4	5	6	7	8	9	10	11	12	13	14	15

- Digit 5**
- 1 Size 1
  - 2 Size 2
  - 3 Size 3
  - 4 Size 4
  - 5 Size 5
  - 6 Size 6

- Digit 1- 2 -3-4**
- 42NC = Standard cabinet
  - 42NR = Cabinet with front return gril
  - 42ND = Standard concealed
  - 42NI = Concealed with plenum in-line
  - 42NU = Concealed with U\_plenum

- Digit 6**
- 1 low efficiency
  - 2 medium efficiency
  - 3 standard efficiency
  - 4 high efficiency

- Digit 7**
- 5 AC motor 5 speed
  - 6<sup>(1)</sup> AC Motor 3 speed
  - 9 EC motor 10 -10V

- Digit 8**
- F = 2 pipes - Left hand
  - G = 2 pipes - Right hand
  - C = 4 pipes - Left hand
  - D = 4 pipes - Right hand

- Digit 9**
- = NO CONTROL SUPPLIED
  - K = NTC Controller AQUASMART EVOLUTION®) without user interface
  - L = WTC Lon without user interface
  - M = WTC BACnet without user interface
  - V = 33TZ Thermostat built-in for Cabinet version (fitted) (only 42NC & 42NR)
  - W = 33TZ Thermostat wall version (not fitted)
  - T = 3-speed control EC motor

- Digit 10**
- = No valve
  - G = 2 ways valve
  - H = 4 ways (3 ways valve with by-pass)
  - L = 2 ways Auto balancing valve without pressure port
  - T = 2 ways Auto balancing valve with pressure drop

- Digit 11**
- = No electrical heater
  - A = Electrical Heater HIGH CAPACITY
  - B = Electrical Heater LOW CAPACITY

- Digit 14**
- = Without
  - A = Air return sensor (only for digit 9 = W)
  - B = Change/over sensor (only for digit 8 =F/G, digit 9 = V/W, digit 10=H)
  - C = Air return + change over sensor (only for digit 8 =F/G, digit 9 = W, digit 10=H)

- Digit 15**
- = Without
  - P = With drain pump (for vertical installation)
  - Q = With drain pump (for horizontal installation)

- Digit 13**
- = Without
  - A = With rectangular flange (only for 42ND)

- Digit 12**
- = Sans
  - A = ON/OFF 230V ACTUATOR
  - B = ON/OFF 24V ACTUATOR (Mandatory digit 9 = - )
  - C = 230V PROPORTIONAL 3-POINTS ACTUATOR (Mandatory digit 9 = - or K/L/M)
  - D = 24V PROPORTIONAL 3-POINTS ACTUATOR (Mandatory digit 9 = - )
  - E = 0-10V ACTUATOR (Mandatory digit 9 = - )

**Nota :**  
 (1) Only available in Sizes 2 & 3



## TECHNICAL DESCRIPTION

### Casing

- Single-unit casing and side members in ABS
- Front/rear panel in galvanised steel with mounting holes for easy fixing.

### Casing for cabinet model

Bi-material casing in two colours:

- Flange, side member and supply air grille in RAL 7035 grey ABS
- Front pressed metal panel painted RAL 9010 white and front mounted return air grille (42NR) in RAL 7035 grey
- Central access point for housing 33TZ thermostat.

### Water coil

- High performance coil concept
- Coil casing in galvanised panels.
- Copper pipes, aluminium louvre or non-louvre fins, patented.
- Water coil tap on the left or right of the unit from the front of the supply air (to be specified when ordering).
- 2 or 4-pipe main coil fitted with ½" or ¾" rotary couplings with air purge and drain screw.
- Additional coil for 4 pipes fitted with ½" rotary couplings with 40 mm centre-to-centre distance.
- Nominal pressure of 16 bar (at 20°C)
- Test pressure 18 bar.
- Maximum hot water inlet temperature:
  - 4-pipe application: 90°C
  - 2-pipe application: 90°C
  - 2-pipe/2-wire application: 55°C (min. air flow: 200 m<sup>3</sup>/h)

### Electric heater

- Single pipe 230V single phase 50/60 Hz electrical elements inserted into the aluminium housing.
- Two capillary tube temperature limiters with manual and automatic reset inserted in the aluminium housing.

### Condensate drain pan

- Pan in ABS PC 10% fibreglass with M1 class reinforced EPS insulation (20 mm thick).
- Reinforced insulation for all climates, M1 class EPS panel (20 mm thick).
- Auxiliary drain pan in ABS.
- 22 mm external Ø raised condensate outlet.

### Fan motor assembly

- Fan(s)

Impeller(s) in ABS in split units for total accessibility of the different parts of the fan motor assembly.

160 mm impeller(s), with exclusive airfoil blades in self-extinguishable HB ABS.

- EC motor

High energy efficiency motor enabling a reduction of up to 85% in electricity consumption.

- Brushless technology.
- Sealed type, tropicalised with protected shaft.
- Progressive control with 0-10V control signal.
- Internal normally closed series automatic overload protection on the windings.
- Mounted on anti-vibration mounts.
- Supply 230V±10%/1-Ph/50-60 Hz.

**Note: The minimum voltage to start up the motor is 2V.**

- Asynchronous motor
  - 5 factory-fitted wired speeds (connected and available at the terminal) for customised adjustment.
  - Sealed, tropicalised type, class F with protected shaft.
  - Permanent capacitor.
  - Ball bearings.
  - Automatic overload protection as standard on winding.
  - Resilient mounts.
  - 230V single-phase 50/60 Hz power supply, reduced consumption.
  - 3-speed asynchronous motor available on sizes 2 and 3.

## TECHNICAL DESCRIPTION

### Electrics box

- Box incorporated on the side of the base opposite the hydraulics.
- Fully encased in an enclosure in PP 20% Talc.
- Electrical connection terminal on DIN rail in compliance with EN 50022, 7,5 mm deep.
- Wire clamps for customer connection.

### Air filter

- Flexible filter medium made of regenerative polyester fibre, on rigid frame.
- Efficiency class EN 779: G3.
- Fire rating: M1.
- Mounted on pivoting runners for easy maintenance

### Packaging

- Delivered in individual boxes on pallets protected by stretch wrap film.

### Controls

- Electronic thermostat : 33TZ (built-in thermostat for vertical model with or without casing or available in wall mounted for all models ) & 33TA/B/C/D (available from ERCD in wall mounted only).
- Networked electronic range (CCN): NTC.
- Networked electronic range (LON or BacNET): WTC.

### Factory-fitted options

- Condensate drain pump.
- Rectangular supply air sleeve for direct distribution in soffit.
- Supply and return air plenum : in line for model 42NI and lateral U for model 42NU for sizes 2 to 4.
- Hydraulic coil with blades protected for use in harmful/corrosive atmospheres (coastal locations, or areas close to chemical industries).
- 3-speed EC motor for subsequent integration (on-site - not factory-fitted) of a 33TZ thermostat or for operation with a thermostat or a 3-speed control.

### Accessories supplied separately

- Support feet or base
- Return air grille between feet
- Rear skirting support and rear painted panel
- Single- or dual-deflection diffusion grille
- Supply air plenum in kit for sizes 1 to 6 diameter 200 mm or 160 mm for sizes 1 to 5
- Resilients mounts (lot of 4 pcs)

**Note: refer to the technical manual and the instruction manual for more information.**

## ASSEMBLY AND DIMENSIONS – CABINET MODEL (VERTICAL APPLICATION)

### 42NR: Unit with return on front

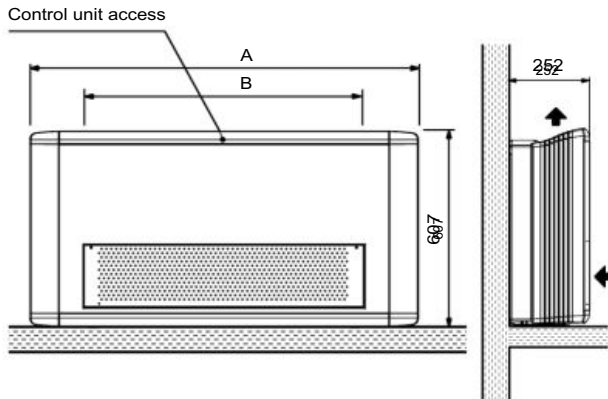

### 42NC: Basic unit with return underneath

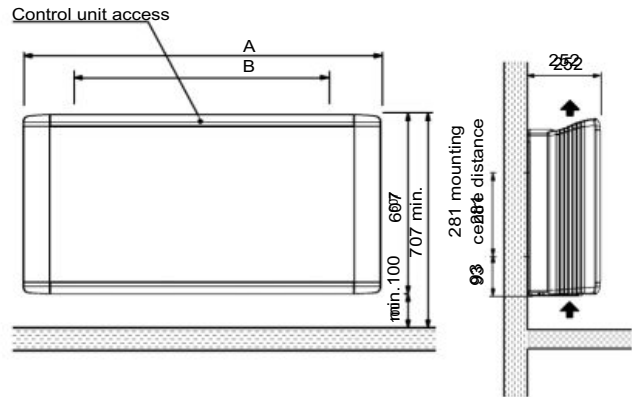

### 42NC + feet: Basic unit with feet

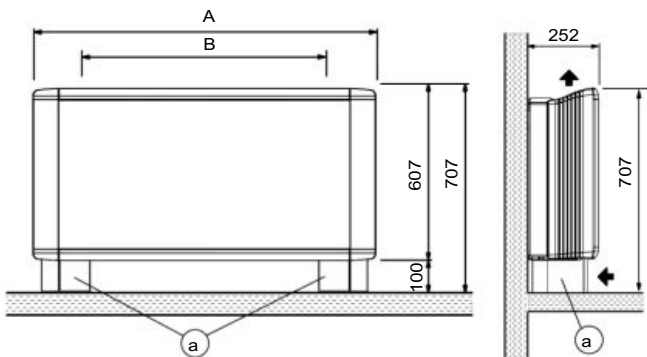

#### Options available with feet:

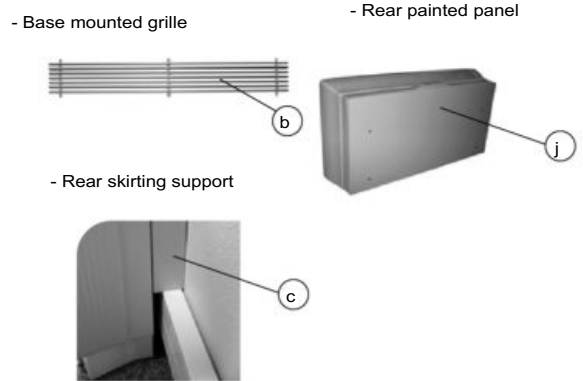

#### Accessories for assembly configurations (supplied separately)

- a: Support feet
- b: Aluminium return air grille between feet
- c: Painted rear skirting support
- j: Rear painted panel RAL 7035

Sizes	A	B mounting centre distance	Weight (kg) <sup>(1)</sup>
1	840	505	20
2	1000	665	23
3	1200	865	28
4	1400	1065	34
5	1600	1265	39
6	1800	1465	44

(1) Weight of the unit in 4-pipe version (without valves)

# ASSEMBLY AND DIMENSIONS – CABINET MODEL (HORIZONTAL APPLICATION)

## 42NR: Unit with return on front

Mounting: 4 sealed M6 shafts, nuts and washers (not supplied)

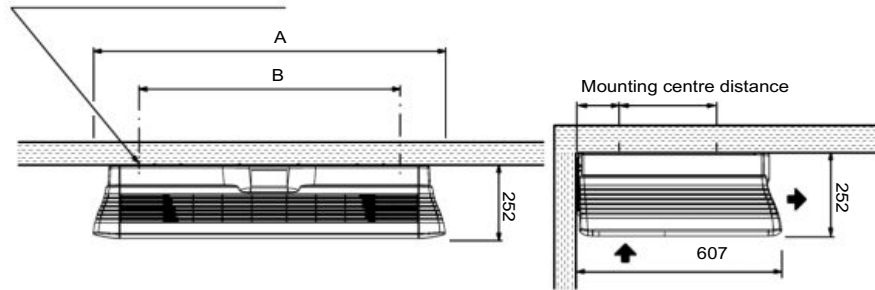

## 42NC: Basic unit

Mounting: 4 sealed M6 shafts, nuts and washers (not supplied)

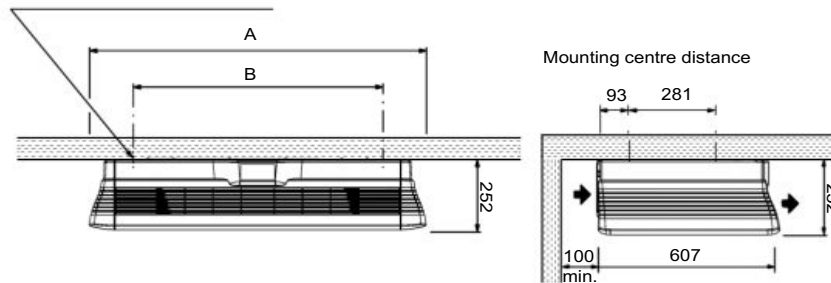

## 42NC + feet: Basic unit with feet

Mounting: 4 sealed M6 shafts, nuts and washers (not supplied)

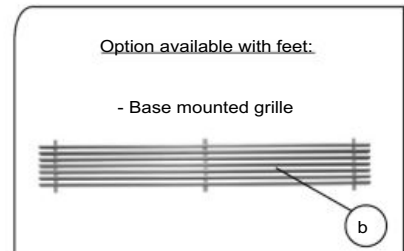
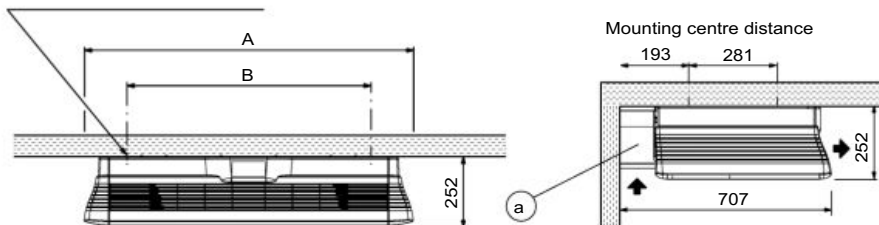

Accessories for assembly configurations (supplied separately)

- a: Support feet
- b: Aluminium internal return air grille between feet

**Note: with feet the condensate drain pump must be used.**

Sizes	A	B mounting centre distance	Weight (kg) <sup>(1)</sup>
1	840	505	20
2	1000	665	23
3	1200	865	28
4	1400	1065	34
5	1600	1265	39
6	1800	1465	44

(1) Weight of heaviest unit in 4-pipe configuration

## ASSEMBLY AND DIMENSIONS – CONCEALED MODEL (VERTICAL APPLICATION)

### 42ND: Basic unit with bottom-mounted return

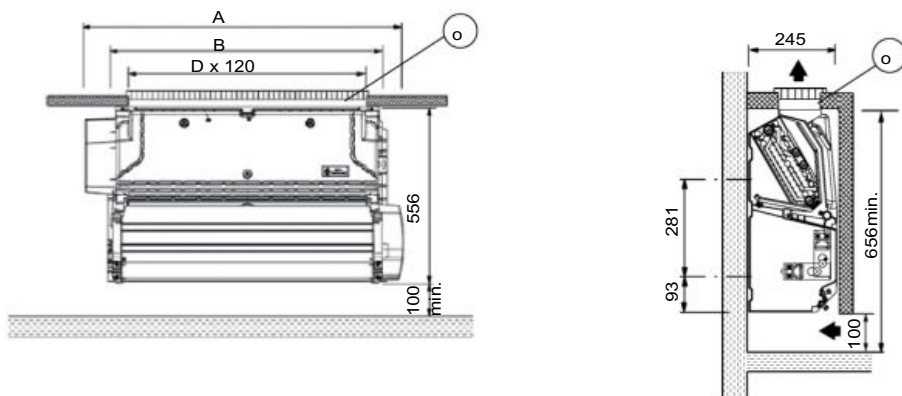

### 42ND + support: Basic unit with support base

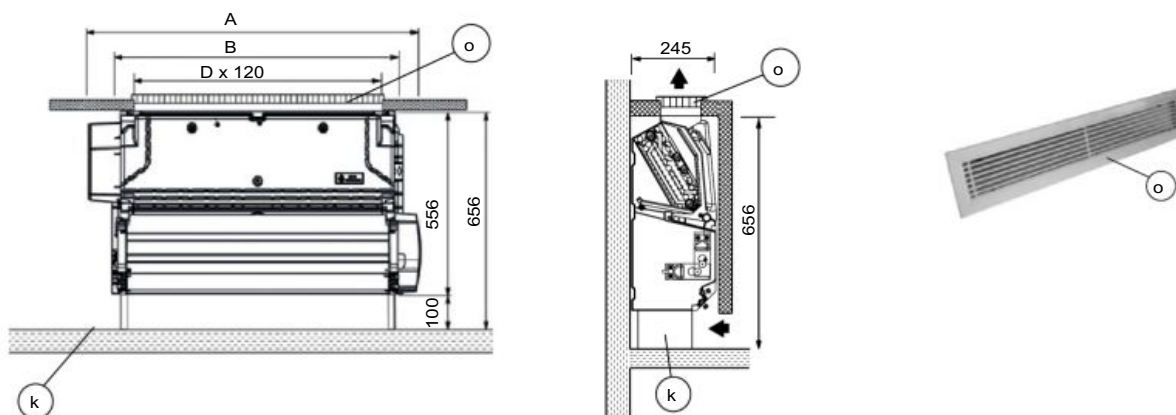

**Accessories for assembly configurations (supplied separately)**

- k: Support base
- o: Aluminium single deflection diffusion or return air grille with sealing frame (without hatch).

**Note: this grille can be used for both return and supply air.**

Sizes	A	B mounting centre distance	D grille space	Weight (kg) <sup>(1)</sup>
1	652	505	355	15
2	812	665	515	18
3	1012	865	715	22
4	1212	1065	915	28
5	1412	1265	1115	32
6	1612	1465	1315	36

(1) Weight of the unit in 4-pipe version (without valves)



## ASSEMBLY AND DIMENSIONS – HORIZONTAL CONCEALED MODEL

### 42ND: Unit with return on front

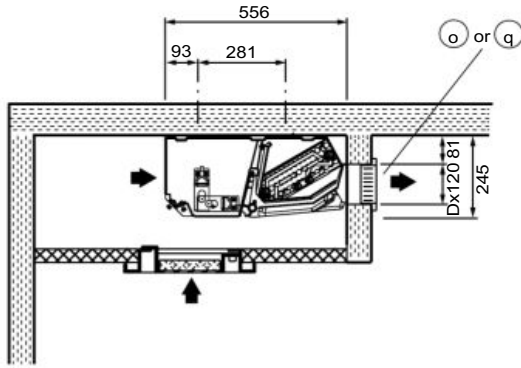

View from beneath

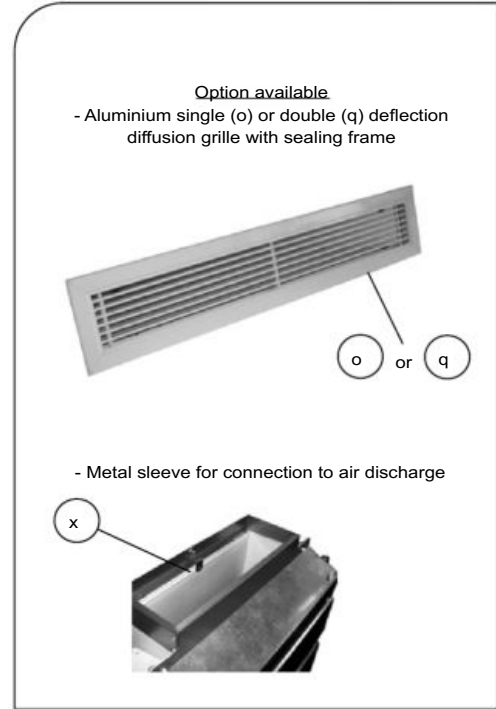
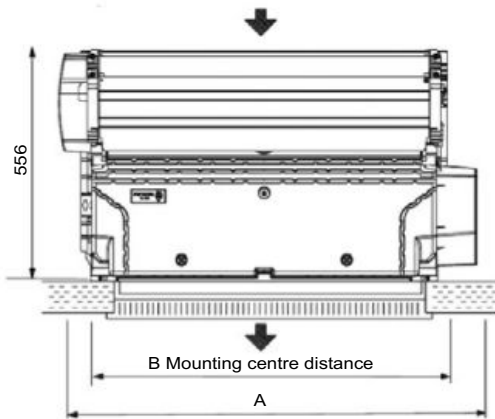

**Accessories for assembly configurations (supplied separately)**

- o: Aluminium single deflection diffusion grille with sealing frame.
- q: Aluminium double deflection diffusion grille with sealing frame
- x: Metal sleeve connecting rectangular sleeve to supply air

Size	A	B mounting centre distance	D grille space	Weight (kg) <sup>(1)</sup>
1	652	505	355	15
2	812	665	515	18
3	1012	865	715	22
4	1212	1065	915	28
5	1412	1265	1115	32
6	1612	1465	1315	36

(1) Weight of the unit in 4-pipe version (without valves)

## ASSEMBLY AND DIMENSIONS – HORIZONTAL CONCEALED MODEL

### 42ND + kit supply plenum Ø 200 mm:

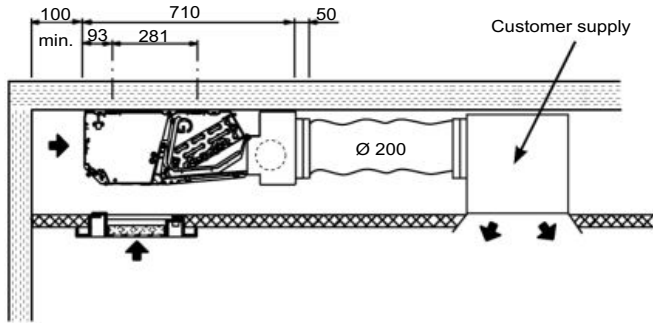

Size	Number of collars	Ø of collars
1	1	200
2	1	200
3	2	200
4	3	200
5	3	200
6	3	200

Supply air plenum delivered not fitted. Available for sizes 1 to 6

### 42ND + kit supply plenum Ø 160 mm:

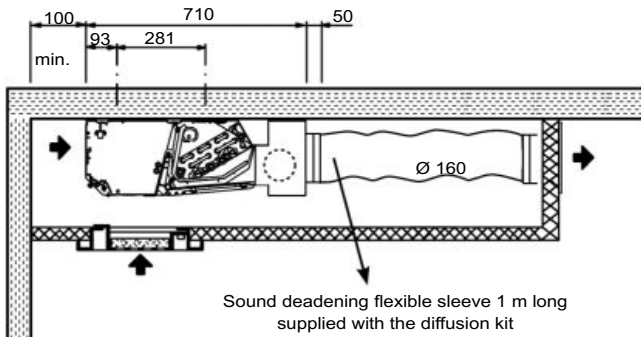

Size	Number of collars	Ø of collars
1	1	160
2	1	160
3	2	160
4	3	160
5	3	160

Supply air plenum delivered not fitted. Available for sizes 1 to 5

### 42NI :

Supply and return air plenum factory-fitted with Ø 200 mm spigots available for sizes 2 to 4

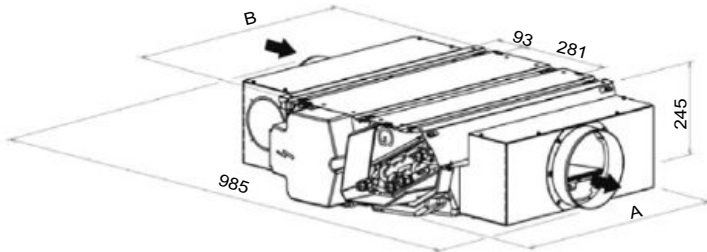

Size	A	B	Number of collars
2	760	665	1
3	960	865	2
4	1160	1065	3

### 42NU:

Supply and return air plenum factory-fitted with Ø 200 mm spigots available for sizes 2 to 4

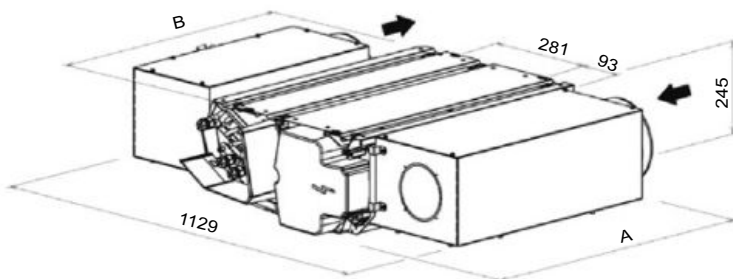

Size	A	B	Number of collars
2	770	665	1
3	970	865	1
4	1170	1065	1

## PERFORMANCE – 2-PIPES SYSTEM

### Eurovent conditions

Cooling mode: water temperature: 7/12 °C, inlet air temperature: 27 °C - 19 °C (WB)

Heating operation: water temperature: 45/40 °C, inlet air temperature: 20 °C

Sizes	AC motor Motor speed	EC motor Voltage (V)	Air Flow (m³/h)	Cooling cap. W		Heating capacity W	Sound power LW dB(A)	Electric consumption W		Electric heater	
				Total	Sensible			AC Motor	EC Motor	Low capacity W	High capacity W
42N-115F/G 42N-119F/G	V4	4,6	265	1 040	990	1 530	46	24	10	300	600
	V3	3,9	225	880	830	1 360	41	19	6		
	V1	2,8	165	710	660	1 030	33	12	5		
42N-135F/G 42N-139F/G	V4	5	265	1 390	1 130	1 880	46	25	11	300	600
	V3	4,2	225	1 200	970	1 600	42	19	8		
	V1	2,9	165	850	670	1 160	36	11	5		
42N-215F/G 42N-219F/G	V4	4,8	415	1 760	1 690	2 500	50	42	15	500	1000
	V3	4,3	370	1 620	1 540	2 330	47	40	12		
	V1	2,7	230	1 150	1 050	1 550	36	33	5		
42N-235F/G 42N-239F/G	V4	4,8	410	2 140	1 800	2 690	50	42	15	500	1000
	V3	4,3	365	1 910	1 640	2 430	46	40	12		
	V1	2,7	225	1 320	1 120	1 670	35	33	5		
42N-236F/G	V3	-	788	4 170	3 310	4 980	65	98	-	500	1000
	V2	-	532	3 190	2 440	3 650	57	82	-		
	V1	-	367	2 420	1 800	2 670	47	59	-		
42N-245F/G 42N-249F/G	V4	4,8	410	2 420	1 960	2 960	50	42	15		
	V3	4,3	365	2 190	1 770	2 650	47	40	12		
	V1	2,7	225	1 480	1 150	1 740	36	33	5		
42N-315F/G 42N-319F/G	V4	5,3	645	2 720	2 150	3 410	53	53	26	800	1600
	V3	4,4	535	2 390	1 870	2 960	47	47	17		
	V1	2,2	230	1 380	1 030	1 670	29	36	4		
42N-325F/G 42N-329F/G	V4	5,3	645	3 160	2 620	3 840	53	53	26		
	V3	4,4	535	2 760	2 250	3 180	47	47	17		
	V1	2,2	230	1 300	1 080	1 680	29	36	4		
42N-335F/G 42N-339F/G	V4	5,3	620	3 510	2 700	4 280	53	53	26	800	1600
	V3	4,4	505	3 050	2 340	3 590	47	47	17		
	V1	2,2	220	1 370	1 060	1 690	29	36	4		
42N-336F/G	V3	-	1062	5 210	4 230	6 410	64	117	-	800	1600
	V2	-	777	4 250	3 350	5 040	57	91	-		
	V1	-	558	3 360	2 580	3 840	49	66	-		
42N-435F/G 42N-439F/G	V4	6,8	1030	5 750	4 480	6 310	60	102	59	1200	2400
	V3	5,4	805	4 740	3 590	5 150	55	87	31		
	V1	3,2	445	2 910	2 160	3 170	41	68	10		
42N-535F/G 42N-539F/G	V4	7,1	1120	6 150	4 840	6 950	60	94	60	1600	3200
	V3	5,8	910	5 350	4 100	5 740	55	80	35		
	V1	3,6	535	3 440	2 620	3 660	42	64	11		
42N-645F/G 42N-649F/G	V4	7,8	1350	7 990	5 970	8 590	63	122	87		
	V3	7,1	1210	7 420	5 550	7 870	61	118	65		
	V1	4,4	730	5 070	3 770	5 230	49	105	18		

**Important: the air supply temperature should not exceed 65°C (CARRIER recommendation).**

**CARRIER participates in the ECP program for Fan Coil Units :**

The certified values are : Input voltage for variable speed units only, Total cooling Capacity, Sensible Capacity, Total heating capacity, Water Pressure Drop, Electric Motor Consumption, Lw (inlet+radiated) and Lw (outlet) for ducted units, Lw (overall) for non-ducted units and Air Flow Rate and External Static Pressure for ducted units only .

## PERFORMANCE – 4 PIPES SYSTEM

### Eurovent conditions

Cooling operation: water temperature: 7/12°C, inlet air temperature: 27°C - 19°C (WB)

Heating operation: water temperature: 65/55°C, inlet air temperature: 20°C

Sizes	AC motor Motor speed	EC motor Voltage (V)	Air Flow (m <sup>3</sup> /h)	Cooling cap. W		Heating capacity W	Sound power LW dB(A)	Electric consumption W	
				Total	Sensible			AC Motor	EC Motor
42N-135C/D 42N-139C/D	V4	5,0	260	1 390	1 130	1 130	46	25	11
	V3	4,2	215	1 200	970	1 030	42	19	8
	V1	2,9	140	850	670	850	36	11	5
42N-235C/D 42N-239C/D	V4	4,8	410	2 130	1 850	1 860	50	42	15
	V3	4,3	365	1 940	1 660	1 760	46	40	12
	V1	2,7	225	1 320	1 120	1 390	35	33	5
42N-236C/D	V3	-	788	3 900	3 200	2 500	65	98	-
	V2	-	532	3 000	2 300	2 000	57	82	-
	V1	-	367	2 200	1 700	1 400	47	59	-
42N-245C/D 42N-249C/D	V4	4,8	410	1 910	1 740	3 420	50	42	15
	V3	4,3	365	1 720	1 560	3 250	46	40	12
	V1	2,7	225	1 200	1 090	2 470	35	33	5
42N-335C/D 42N-339C/D	V4	5,3	620	3 310	2 690	2 980	53	53	26
	V3	4,4	505	2 790	2 280	2 650	47	47	17
	V1	2,2	220	1 200	1 040	1 540	29	36	4
42N-336C/D	V3	-	1062	5 210	4 000	6 100	64	117	-
	V2	-	777	4 700	3 700	5 200	57	91	-
	V1	-	558	3 800	3 100	4 200	49	66	-
42N-345C/D 42N-349C/D	V4	5,3	620	2 930	2 390	4 730	53	53	26
	V3	4,4	505	2 550	2 040	4 150	47	47	17
	V1	2,2	220	1 180	960	2 130	29	36	4
42N-435C/D 42N-439C/D	V4	6,8	1030	5 480	4 300	4 110	60	102	59
	V3	5,4	805	4 650	3 570	3 600	55	87	31
	V1	3,2	445	2 940	2 190	2 610	41	68	10
42N-445C/D 42N-449C/D	V4	6,8	1030	4 910	4 080	5 720	60	102	59
	V3	5,4	805	4 150	3 380	4 990	55	87	31
	V1	3,2	445	2 650	2 070	3 600	41	68	10
42N-535C/D 42N-539C/D	V4	7,1	1120	5 880	4 810	5 770	60	94	60
	V3	5,8	910	4 980	4 070	5 090	55	80	35
	V1	3,6	535	3 330	2 590	3 790	42	64	11
42N-635C/D 42N-639C/D	V4	7,8	1250	8 150	6 040	9 150	64	120	82
	V3	7,1	1120	7 460	5 550	8 160	62	117	61
	V1	4,5	680	4 960	3 670	6 270	50	105	19

### CARRIER participates in the ECP program for Fan Coil Units :

The certified values are : Input voltage for variable speed units only, Total cooling Capacity, Sensible Capacity, Total heating capacity, Water Pressure Drop, Electric Motor Consumption, Lw (inlet+radiated) and Lw (outlet) for ducted units, Lw (overall) for non-ducted units and Air Flow Rate and External Static Pressure for ducted units only .

## TECHNICAL CHARACTERISTICS

### Coil capacity (litres)

		115/119	135/139	215/219	235/239	245/249	315/319	325/329	335/339	435/439	535/539	645/649
2-pipe system	Hot or cold water coil	0,23	0,33	0,30	0,45	0,53	0,40	0,47	0,63	0,84	1,03	1,33
		135/139	235/239	245/249	335/339	345/349	435/439	445/449	535/539	635/639		
4-pipe system	Cold water coil	0,33	0,45	0,36	0,60	0,52	0,71	0,72	1,11	1,32		
	Hot water coil	0,075	0,098	0,19	0,13	0,21	0,22	0,24	0,274	0,47		

### Coil connection diameters

- Coil connection type: rotary couplings with flat face;
- Valve connection type: install flush fit male threaded unions.

		115/119	135/139	215/219	235/239	245/249	315/319	325/329	335/339	435/439	535/539	645/649
2-pipe system	Hot or cold water coil	G1/2"	G1/2"	G1/2"	G1/2"	G1/2"	G1/2"	G1/2"	G1/2"	G1/2"	G3/4"	G3/4"
		135/139	235/239	245/249	335/339	345/349	435/439	445/449	535/539	635/639		
4-pipe system	Cold water coil	G1/2"	G1/2"	G1/2"	G1/2"	G1/2"	G1/2"	G1/2"	G3/4"	G3/4"	G3/4"	
	Hot water coil	G1/2"	G1/2"	G1/2"	G1/2"	G1/2"	G1/2"	G1/2"	G1/2"	G1/2"	G1/2"	

### Motor specifications

	Motor speed	AC Motor Asynchronous ( 230V/50Hz)								EC Motor Brushless ( 230V/50Hz)					
		115/135	215/235/245	236	315/325/335/345	336	435/445	535/545	635/645	119/139	219/239/249	319/329/339/349	439/449	539	639/649
Power input during operation (W)	V5	33	58	-	88	-	106	108	135	11	25	32	77	90	100
	V4	31	41	-	67	-	93	94	114	9	15	22	63	80	75
	V3	29	36	98	52	117	80	79	99	6	11	13	36	42	55
	V2	27	31	82	42	91	72	72	88	5	8	7	21	26	32
	V1	26	27	59	35	66	63	63	77	4	5	3	11	13	16
Max. absorbed current (A)	V5	0,14	0,25	-	0,38	-	0,46	0,47	0,59	0,11	0,2	0,29	0,62	0,71	0,74
	V4	0,13	0,18	-	0,29	-	0,4	0,41	0,5	0,09	0,13	0,2	50	0,62	0,67
	V3	0,13	0,16	0,42	0,23	0,5	0,35	0,34	0,43	0,07	0,11	0,13	0,3	0,35	0,44
	V2	0,12	0,13	0,35	0,18	0,39	0,31	0,31	0,38	0,06	0,09	0,08	0,19	0,21	0,27
	V1	0,11	0,12	0,26	0,15	0,28	0,27	0,27	0,33	0,06	0,06	0,06	0,11	0,13	0,16

**Note:** Specifications determined for 230V +/-10% - 50Hz supply.

For operation at 60 Hz, the power input and rotation speed values are generally higher. Motor operating range:  
 minimum return T°C: 0°C,  
 maximum return T°C: 40°C



## TECHNICAL CHARACTERISTICS

### Unit information plate

The information plate shows all the information needed to identify the unit and its configuration. This plate is located on the condensate pan, on the electrical connection side.

- ① Code
- ② Serial number
- ③ Description of the unit
- ④ Nominal motor output
- ⑤ Motor rotation speed
- ⑥ Coil type
- ⑦ Wiring diagram reference
- ⑧ Motor speed wiring
- ⑨ Maximum operating pressure
- ⑩ Electrical heater specifications (if fitted)

Ref.Produit/item Ref.		Designation/Description	
7552742		42ND539FMGAA - CP	
An./Year	N. Serie/Serial Nbr	Composants/Components	
2019	02786871/0001		
Moteur/Motor (Ph/Hz/V)	Batterie/Hydro. coil	Fluide/Fluid	
1+ N 50/60HZ 230/220V +T	2T	EAU	
P. moteur/Motor P. (W)	Elec Element (Ph/Hz/V)	Maxi pressure (bar)	
118,9/142,7	1+ N 50/60HZ230/220V	1600000 PA (16BAR)	
I. moteur/Motor I. (A)	Elec Elem. P. (W)/I. (A)	Cablage/Wiring	
0,89/1,07	3200	SANS	
tr.mm - 1/rp.m	Elec Diagram	N° Incorporation CE	
	7547562		

CARRIER SCS  
 Route de Thil  
 01122 Montluel - France  
 Tel : (00 33)4 72 25 21 21

Made in France

## CONDENSATE DRAIN PUMP

### Technical characteristics

The pump outlet must be connected to the wastewater pipe by a flexible tube with an internal diameter of 6 mm (not supplied).

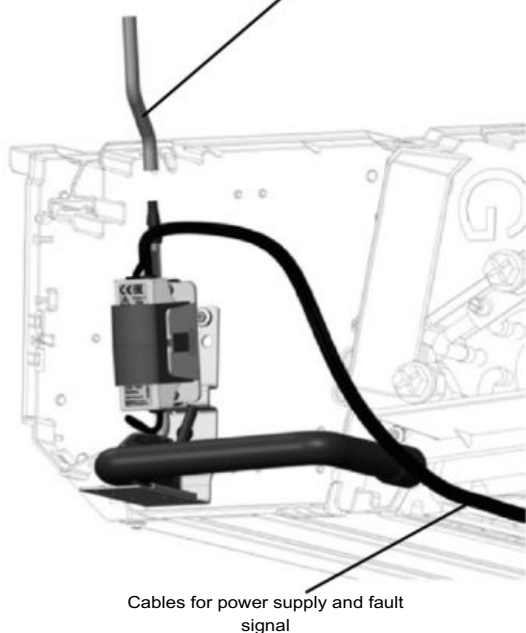

Maximum flow rate	10,4 l/h
Maximum discharge height	7 m (flow rate = 4 l/h)
Maximum pressure	10 m (flow rate = 0 l/h)
Sound level at 1 m in accordance with EN ISO 3744 and 4871 (Measurement taken at LNE, pump in water, outside of application)	20,2 dBA
Power supply	230 V +10%/-15% - 50/60 Hz - 19 W
Electrical insulation class	Class 1
Detection levels	ON: 14,7 mm, OFF: 10,7 mm, AL: 17 mm
Safety switch	NF: 5 A resistance - 250 V Contacts made from AgNI 90/10, gold-plated.
Thermal protection (overheating)	70°C (automatic restart)
Operating cycle (duty factor)	100%
Protection (according to NF EN 60529)	IP64
Safety standard	CE
RoHS directive	Compliant
WEEE directive	Compliant

#### Pump performance: Water flow rate in litres per hour (-15 %/+20 %)

Discharge height	Horizontal length of the discharge pipe			
	5 metres	10 metres	20 metres	30 metres
1 metre	10,4	9,1	8,3	7,3
2 metres	8,5	7,8	7	6,4
3 metres	7,9	7,1	6,3	5,8
4 metres	7	6	5,3	4,9

#### Operating limit:

Drainage: → 6 mm int. flexible pipe,

→ 8,8 mm end piece. This accessory must be paired with a valve control to allow the upper safety limit to control the valve's closure (stop condensate).

Condensate flow rate (l/h) =

$$\frac{\text{Total capacity} - \text{Sensible capacity (W)}}{680}$$

## OPTIONS (FACTORY FITTED)

42NC/42NR	42ND/42NI/42NU	Figures	Digit number	Description
•	•		14	Condensate drain pump fitted to unit with high safety device.
	•		13	Metal sleeve for connection to air discharge

## FACTORY ACCESSORIES (DELIVERED SEPARATELY)

Figures	Description		SIZE 1	SIZE 2	SIZE 3	SIZE 4	SIZE 5	SIZE 6
	Support feet for cased model	Code	7242933					
	Internal return air grille between feet	Code	7242935	7242936	7242937	7242938	7242939	7242940
	Rear skirting support in RAL7035 light grey, 55 mm thick (for 70 mm skirting)	Code	7242926	7242927	7242928	7242929	7242930	7242931
	Rear painted panel in RAL7035 light grey for positioning the unit by a window	Code	7262703	7262704	7262705	7262706	7262707	7262708
	Support base for Concealed unit	Code	7242932					
	Single deflection diffusion grille with sealing frame for vertical and horizontal Concealed models	Code	7256897	7256898	7256899	7256900	7256901	7256902
	Double deflection diffusion grille with sealing frame for horizontal Concealed models	Code	7242942	7242943	7242944	7242945	7242946	7242947
	Supply plenum with Spigots Ø 200 mm	Code	7512282	7512284	7512286	7512288	7242995	7242996
	Supply air plenum with Spigots Ø 160 mm	Code	7512283	7512285	7512287	7512289	7243490	
	Resilient mounts supplied separately (4 per unit)	Code	0219453					

## COANDA EFFECT CASSETTE



- Optimised Coanda Effect
  - Thermal comfort
  - Indoor air quality
- Responsiveness of the system and individual adjustment
- Low energy consumption
  - Acoustic comfort
- Perfect integration : suitable for 600 x 600 mm false ceiling grid as standard
- Ease of maintenance

## 42KY

Cooling capacity: 1 kW to 6 kW  
Heating capacity: 2 kW to 10 kW

Energy performance, comfort and indoor air quality: Carrier's 42KY cassette is the all-in-one solution to meet heating and cooling requirements for commercial buildings and provide optimum comfort for users.

This low consumption (LEC) variable speed active comfort unit makes it possible to adapt the indoor temperature automatically and independently to the preferences of occupants with very quick response times.

Optimisation of the Coanda Effect for air diffusion, to meet the requirements of the standard NF EN ISO 7730, ensures perfect control of thermal phenomena that can cause discomfort. Carrier's 42KY cassette makes it possible to eliminate the draughts that are felt with sweeping diffusion systems or those with direct airflow onto the occupant.

Eco-designed product that is 90% recyclable, the 42KY cassette has been developed to limit its impact on the environment throughout its life cycle.



CARRIER participates in the ECP programme for LCP-HP  
Check ongoing validity of certificate:  
[www.eurovent-certification.com](http://www.eurovent-certification.com)

## OPERATION AND ADVANTAGES

### Use

The air treatment unit is fitted within the suspended ceiling, at the edge of the room, with the outlet facing the windows. It has all the economical advantages that come from installing and operating a central heated and chilled water production unit. The location facilitates hydraulic connection via the suspended ceiling of the adjoining corridor, and gravity draining of condensate (no pump).

The 42KY cassette must be suspended from the ceiling with four 6 mm or 8 mm threaded rods (not supplied), that are fixed to the four mounting brackets of the device with elastic anti-vibration mounts or a nut/washer assembly fitted either side of the mounting bracket.

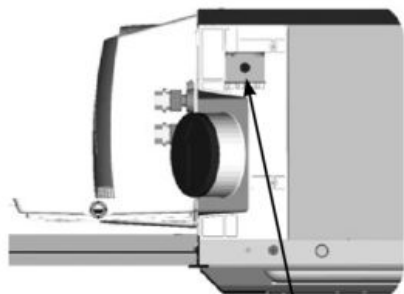

Mounting brackets (x4)



Mounting principle  
2 methods

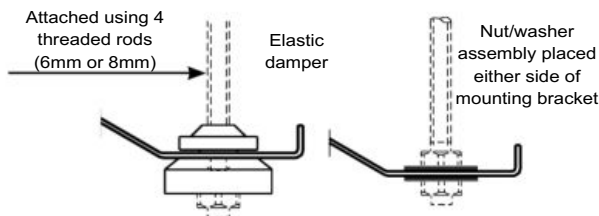

Diffuser mounting system  
with 4 captive screws

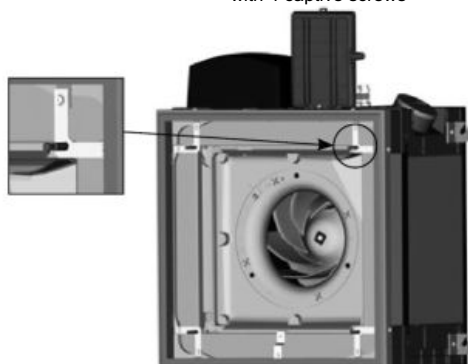

### Operating principle

The centrifugal turbine draws air through a perforated metal intake grille. The air is filtered, then heated or cooled through a temperature exchange coil fed with either hot or chilled water. The air is then pulsed horizontally at 180° or 360°, by means of the Coanda Effect in the room to be treated.

### The Coanda effect

Coanda effect diffuser:

The single slot peripheral outlet with its narrow opening and specific internal profile will increase the initial speed of the air as it leaves the diffuser. The high speed of the moving flow of air causes an area of low pressure which keeps it close to the ceiling, (there is no direct blast on occupants) and the ambient air is drawn in by induction to be reinjected in the air stream. The air mix rate, the range and the coverage of the air flow are improved, which reduces thermal phenomena that cause discomfort in the occupied area (residual air flow rate, asymmetric temperatures, radiation caused by walls, etc.).

### "Anti cold shower" system

The one-way 180° diffuser is fitted with an "anti cold shower" system that maximises comfort by preventing cold air from falling between two cassettes.

The system incorporates two deflectors in the insulation which offsets the air stream slightly in the lateral axis. When the units are placed side by side in the same room, the air flows do not oppose one another and cross over in parallel, which avoids any cold air draughts.

This patented system removes the discomfort caused by draughts without having to reduce the outlets and with no increased noise levels, while maintaining the air flow necessary for the thermal requirements.

### with anti "cold shower" system



### without anti "cold shower" system





## OPERATION AND ADVANTAGES

### Fresh air inlet spigot

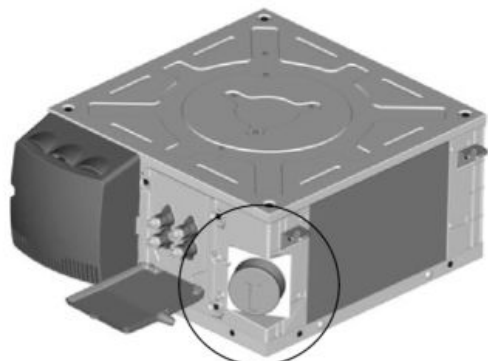

Ø 100 mm spigot, max. air flow 90 m<sup>3</sup>/h recommended. Network balancing system not supplied by Carrier.

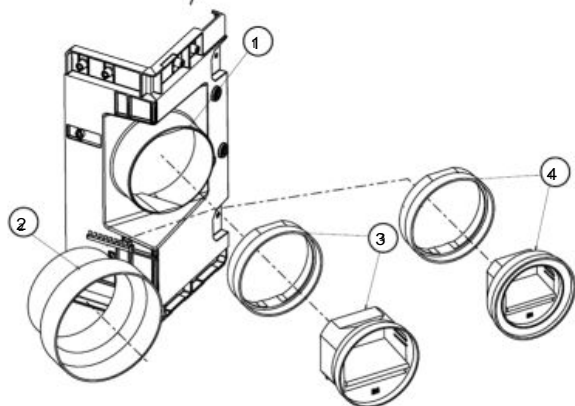

- ① Fresh air inlet on device
- ② Ø100 / Ø125 mm adapter
- ③ 60/75/90 m<sup>3</sup>/h air flow controller kit
- ④ 15/30/45 m<sup>3</sup>/h air flow controller kit

### Innovative design

- Next generation chassis that combines high density EPS for its thermal and phonic properties, ABS PC and a ribbed galvanised sheet steel base to stiffen the assembly.
- Chassis with unique dimensions for all sizes, adapted to the suspended ceiling grid size 600 x 600 mm.
- Hydraulic, air and electrical connections on the same side to facilitate installation and access for maintenance operations.
- Fresh air inlet with 100 mm sleeve integrated to the chassis with removable plug.

### Range

The 42KY one-way cassette range includes 3 models that cover a flow rate from 250 to 770 m<sup>3</sup>/h which meet the most stringent of sound level requirements.

The 42KY is available as:

- 2-tube system, with heating or cooling mode.
- 2-tube + 2-wire system, with heating + cooling/cooling + electric mode.
- 4-tube system, with heating and cooling mode.

### Advantages

- Individual adjustment of the indoor temperature.
- Responsive system.
- Large power range.
- Coanda effect diffusion over 180 or 360° for even coverage and perfect control of the thermal phenomena that can cause discomfort.
- Acoustic comfort.
- LEC low consumption motor.
- G3 filter.
- Optimised hydraulic coil.
- Condensate drain by gravity avoiding the need for a drain pump.
- Modern and elegant design for perfect integration.
- Eco-designed product that is 90% recyclable. The 42KY cassette has been developed to limit its impact on the environment throughout its life cycle.
- Ease of maintenance.

### Greater comfort

Optimised Coanda Effect diffusion for perfect control of thermal phenomena that can cause discomfort and make the room feel draughty.

### Compliance with energy requirements

- Optimised temperature exchange coils to meet low energy buildings requirements as well as cost limitation
- LEC low consumption motor.
- Reduction in power of the electric heating coils to match the requirements of new buildings.

### Eco-design

#### Raw materials

30% saving in weight and 21% saving in volume thanks to a compact and well thought out architecture.

Use of easily recyclable materials (EPS and ABS).

#### Transport

Raw material suppliers selected from those that are less than 100 km from our manufacturing and packaging factory, enabling a 50% gain in volumes transported (reduction in CO<sub>2</sub> emissions).

#### Recycling and ease of disassembly

90% recyclable products.

Materials can be completely separated and fixings have been reduced by 40% to allow greater efficiency at recycling plants.





## OPERATION AND ADVANTAGES

### Ease of installation and operation

The 42KY cassette is designed to be easy to fit and not require many on-site operations:

- Fitting template provided with each unit to mark out the anchoring points on the ceiling.
- Optimised weight and size to facilitate handling during installation.
- Mounting brackets equipped with anti-slip system to hold the threaded rods when attaching and levelling the unit.
- Safety system to suspend the diffuser leaving the technician's hands free to tighten the mounting bolts.

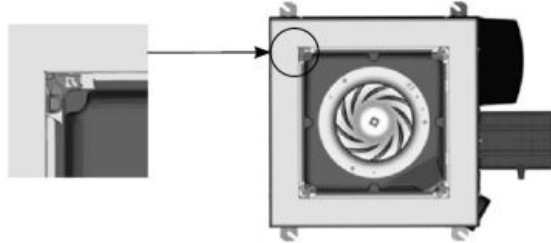

- Technical plate containing all connections (electrical, air and hydraulic) on one face.
- Fresh air inlet sleeve with plug integrated directly to the chassis (no fitting necessary).
- Large electrical box with single latch that can house all the control systems of the Carrier range.
- Access to internal components without the need to open suspended ceilings, easy to open filter hatch grille that is hinged to facilitate maintenance operations.
- Diffusion panels supplied in individual packaging, making it easier to fit the unit with no risk of damaging or soiling visible parts during installation.

## CODES

Product ref.	Range				Size	Motor	Coils	Control	Valves	Elec heater	Valve servomotors	Sensors	Condensate drainage	Grille adaptation	Coil protection	Modif. index
	4	2	K	Y	1	9	C	-	G	A	-	A	P	T	-	A
Digit	1	2	3	4	5	6	7	8	9	10	11	12	13	14	15	16

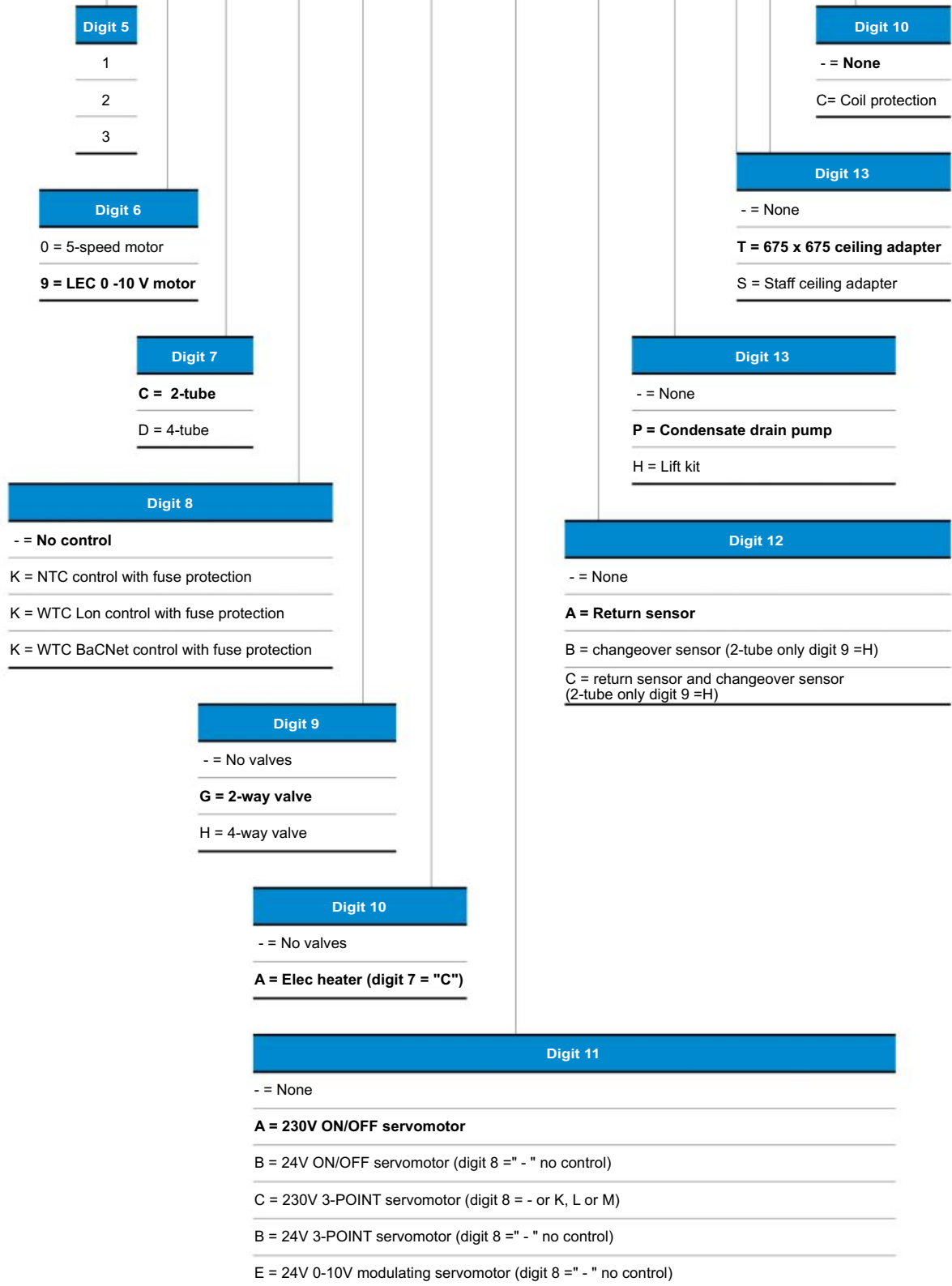

## TECHNICAL DESCRIPTION

### Return/supply interface

#### Coanda Effect diffusion through a single slot with a narrow opening and specific internal profile.

- 180° diffusion (1-way) or 360° diffusion (4-way)
- In sheet metal painted in RAL 9010 to be fitted over the chassis with exactly the same dimensions as a standard suspended ceiling tile.
- Perforated metal return grille with hinge-mounted filter housing that requires no tools to open it.
- PSE insulation, M1 fire resistance with very low heat transfer coefficient.
- Flat G3 filter on metal frame.

### Chassis

- Unique chassis and reduced footprint for all sizes fitted in place of a suspended ceiling tile, either 600 x 600 mm or 675 x 675 mm (optional).
- Ribbed galvanised steel motor support base panel, 10/10th thick.
- High-density PSE casing integrating thermal and acoustic functionalities. 15 mm thick base and 25 to 30 mm thick vertical sides that make up the casing.
- Low emission of TVOCs and no halogenated compounds.
- ABS corner reinforcements fitted with open galvanised steel mounting brackets with one-way system for assembly of threaded rods.
- M1 fire rating.
- Hydraulic, air and electrical connections on the same side of the technical panel at the rear of the unit providing a single access point.
- Galvanised 0.8 mm sheet metal frame finished in RAL 9010 to which the diffusion interface is fixed.

### Water coil

- 1 hot water or cold water circuit (2-tube system).
- 1 hot water circuit + 1 cold water circuit (4-tube system).
- One-piece coupling with 40 mm centre to centre distance with integrated sealed flush fitting female revolving unions and gaskets, for easy fitting of the control valves.
- One, two or three row circular coil with low pressure drop.
- Copper tubes, one-piece aluminium fins (1.6 mm pitch).
- Bleeding and draining.
- Rated pressure of 16 bar (at 20°C).
- Test pressure: 24 bar.
- Max hot water inlet temperature:
  - 4-tube application: 80°C,
  - 2-tube application: 70°C,
  - 2-tube/2-wire application: 55°C (min air flow rate: 200m<sup>3</sup>/h).
- Min cold water inlet temperature: 6°C.

### Electric heater (2-tube + electric system)

- 230V/1/50 single-tube electrical elements inserted into the aluminium housing.
- 2 temperature limiters, manually and automatically reset, inserted in the aluminium block with easy access that does not require the suspended ceiling to be opened, via the return/supply air interface.
- Heater element power supply on the connection terminal inside the electrics box.
- Option to deactivate a heater element on site by means of a shunt on the terminal to reduce the electrical power.
- Condensate drain pan
- Single-piece all-climate primary pan in high density watertight EPS, naturally tilted and can be removed from underneath with no need to open the suspended ceiling.
- M1 fire rating class.
- PC ABS auxiliary pan (configured to prevent standing water) to be used to catch condensate from valves from the primary pan.
- Gravity drain: height 70mm.
- Drainage bushing: external Ø 15 to 20 mm.

### Fan motor assembly

#### LEC motor (low energy consumption)

##### Low energy motor making it possible to reduce electrical consumption by up to 85%.

- Sealed, tropicalised, with protected shaft.
- Progressive control with 0-10V control signal.
- Internal automatic heat protection with serial opening on winding.
- Mounted on rubber mounts.
- 230V/1Ph/50 Hz power supply (60Hz compatible).

**Note:** The minimum voltage to start up the motor is 2V.

**Or**

#### Asynchronous motor

5 factory-wired speeds connected to a terminal strip for customisation.

- Sealed, tropicalised, with protected shaft.
- Permanent capacitor.
- Ball bearings.
- Internal automatic heat protection with serial opening on winding.
- Resilient mounts.
- 230V/1Ph/50 Hz power supply (60Hz compatible).
- High efficiency and power factor.

#### Fan(s)

- Balanced centrifugal impeller (Ø 282 mm) with airfoil blades.
- Polymer impeller.
- Single-point mounting system with foolproofing device.

## TECHNICAL DESCRIPTION

### Electrics box

- Large ABS electrics box, with a hinge to keep it open and screw closure.
- Protection rating IP20.
- Terminal block on DIN rail in accordance with EN 50022, depth 7.5 mm.
- Junction block located with tension clamp. Cross section 0.5 to 2.5 mm<sup>2</sup> - Max current: 24A – Shock resistance: 8 kV. Cable routing for customer connections.

### Fresh air inlet sleeve

Connecting sleeve for fresh air inlet, Ø100 mm, integrated to the chassis with removable plug.

### Filtration

- Regenerative flexible polyester fibre filter element.
- Positioned at the fan inlet.
- EN779 efficiency Class: G3.
- On rigid metal frame.
- Accessed via the hinged inlet grille.
- Low energy impact.
- M1 fire rating.
- A protected air stream which prevents particles being drawn into suspended ceilings.
- Uniform treatment of the room thanks to optimised diffusion using the Coanda effect.
- Suitable mixing rate.

### Device mounting

- Open mounting brackets, factory-fitted, made from galvanised steel, 15/10th thick, with check valve for securing the threaded rods during fitting and levelling.

### Packaging

- Strapped cardboard crate for the casing.
- Fitting template and direction of fitting printed on the cardboard.
- Return/supply air interface supplied separately in protective cardboard packaging.
- Delivered on a plastic-wrapped pallet.

### Control systems

- A-B-C-D type electronic thermostats.
- NTC / Aquasmart Evolution networked electronic control.
- WTC LON or BACnet networked electronic control.

### Options (factory assembled)

- Condensate drain pump.
- Lift kit.
- Finishing trim frame for 675 x 675 mm suspended ceiling tiles.
- Finishing trim frame for STAFF ceilings.
- Hydraulic coil with protected fins for aggressive / corrosive areas (locations close to the sea or to chemical industries).

### Accessories (available separately)

- Vibration damping rubber mounts for mounting brackets.
- Self-regulating conditioned fresh air inlet module (3 flow rates adjustable using a set of shims).
- Ø 100-125 mm sleeve adapter.
- Condensate drain pump kit with high safety device.
- 80 mm riser kit for gravity drainage without condensate drain pump.
- Finish counter frame kit for 675 mm suspended ceiling tile.

## INTEGRATION INTO THE SUSPENDED CEILING

Mounting position with 600 x 600 mm suspended ceiling on T-shaped profile

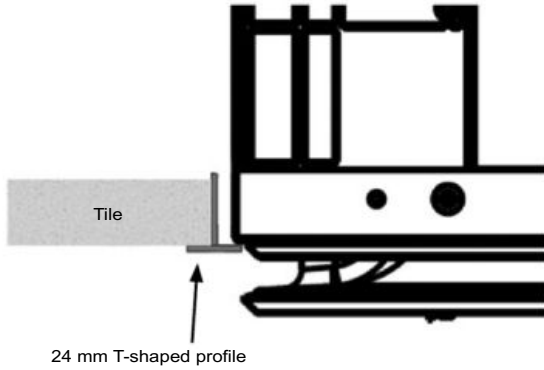

Mounting position with 600 x 600 mm suspended ceiling on T-shaped profile with 8 mm shadowgap

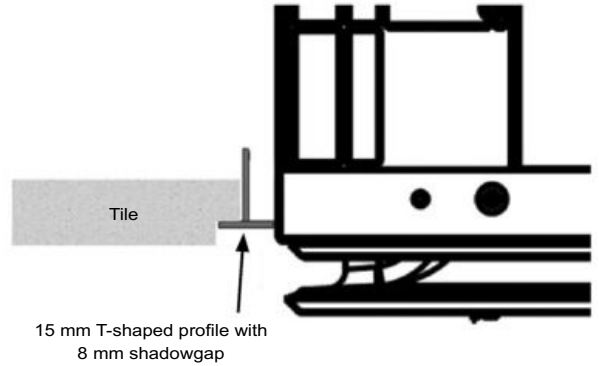

## DIMENSIONS

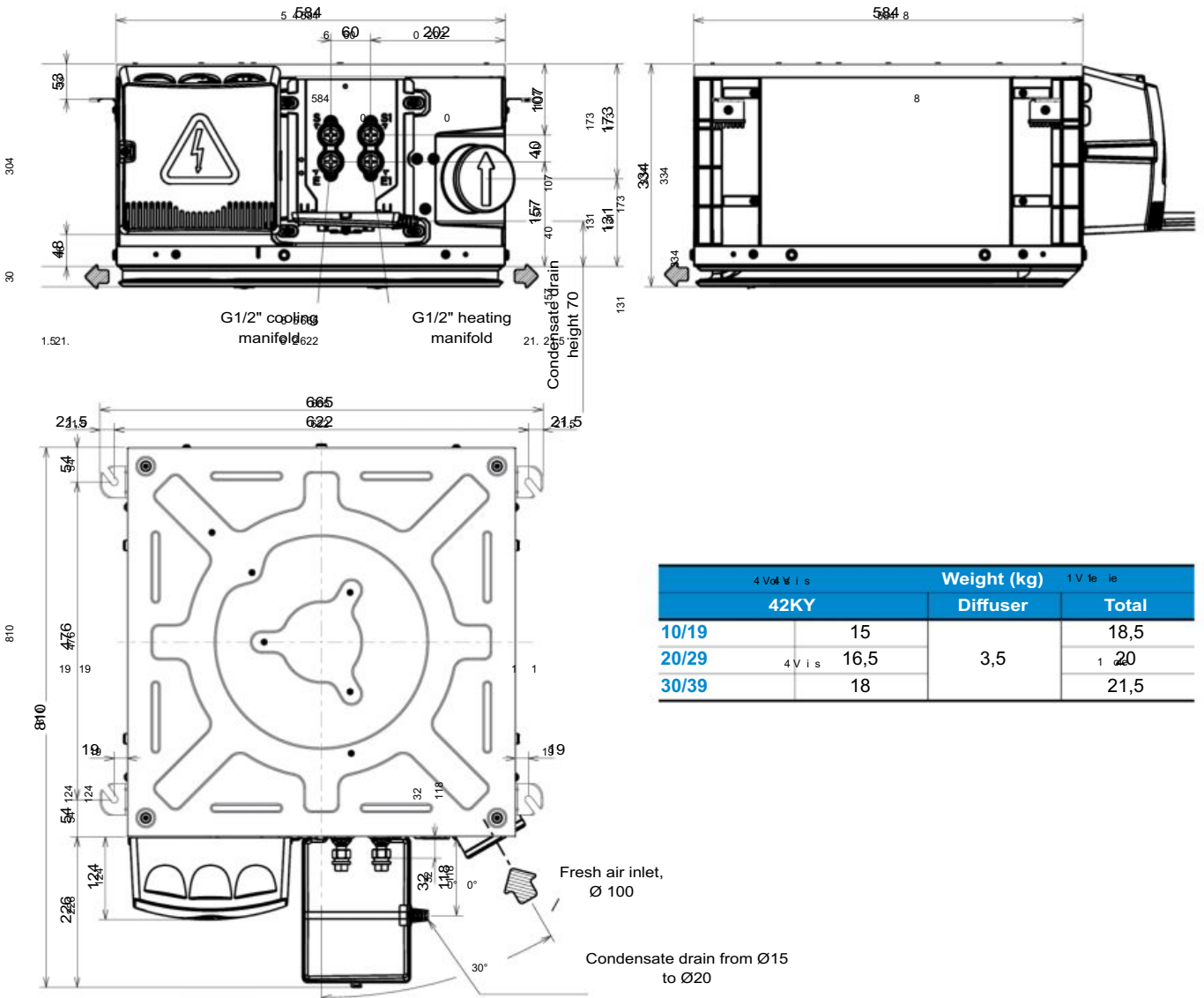

	4 V o l u m e		Weight (kg)	
	42KY	Diffuser	1 V o l u m e	Total
10/19	15			18,5
20/29	16,5	3,5		20
30/39	18			21,5



## SPECIFICATIONS FOR UNITS UNDER EUROVENT CONDITIONS

### 2 pipes application

Model	Speed	Voltage	Input Power	Air flow	Heating capacity	Pressure drop heating	Cooling capacity		Pressure drop cooling	Lw	LP	Comfort level (ISO or NR)	Average air temperature rise in K Auxiliary electric heater 230/1/50	
		v	W	m <sup>3</sup> /h	W	kPa	Total W	Sensible W	kPa	dB(A)	dB(A)			
42KY10C-----	HS		45	440	2 000	12,8	1 700	1 550	10,7	49	37	32		
	MS		41	380	1 800	10,7	1 530	1 390	8,9	46	34	29		
	LS		34	235	1 350	6,3	1 190	1 030	5,5	37	25	19		
42KY19C-----	HS	4,9	17	440	2 070	13,0	1 700	1 550	10,5	49	37	32		
	MS	3,4	8	310	1 650	9,0	1 370	1 220	6,9	42	34	29		
	LS	2,5	5	235	1 400	7,0	1 190	1 040	5,3	37	25	19		
42KY20C-----	HS		45	420	2 700	17,2	2 600	2 030	18,7	51	39	34		
	MS		41	360	2 300	13,7	2 280	1 750	14,8	47	35	30		
	LS		34	215	1 550	7,0	1 580	1 150	7,6	35	23	18		
42KY29C-----	HS	4,9	17	420	2 700	17,2	2 590	2 020	18,4	51	39	34		
	MS	4,2	12	360	2 300	13,7	2 280	1 760	14,5	47	35	30		
	LS	2,5	5	215	1 550	7,0	1 580	1 150	7,3	35	23	18		
42KY20C--A-----	HS		45	420	2 390	11,4	2 050	1 800	9,9	51	39	34	900W (2R)	
	MS		41	360	2 200	9,4	1 870	1 580	8,4	47	35	30		6,4
	LS		34	215	1 600	5,4	1 420	1 090	5,1	35	23	18		7,4
42KY29C--A-----	HS	4,9	17	420	2 390	11,6	2 040	1 790	9,7	51	39	34	900W (2R)	
	MS	4,2	12	360	2 200	9,6	1 870	1 590	8,2	47	35	30		6,4
	LS	2,5	5	215	1 600	5,6	1 420	1 090	4,8	35	23	18		7,4
42KY30C-----	HS		77	660	4 150	23,5	4 340	3 260	29,5	58	46	40		
	MS		56	525	3 350	16,0	3 540	2 620	20,2	51	39	34		
	LS		40	405	2 600	10,3	2 840	2 070	13,3	45	33	27		
42KY39C-----	HS	6,7	38	660	4 150	23,5	4 350	3 270	29,1	58	46	40		
	MS	5,3	21	525	3 350	16,0	3 540	2 630	19,8	51	39	34		
	LS	3	6	290	1 900	6,0	2 210	1 570	8,6	38	26	19		
42KY30C--A-----	HS		77	660	4 050	19	3 833	3 009	9,9	58	46	40	1200W (2R)	
	MS		56	525	3 300	13,1	3 169	2 442	8,4	51	39	34		5,4
	LS		40	405	2 720	8,8	2 600	1 955	5,1	45	33	27		6,8
42KY39C--A-----	HS	5,3	21	525	3 320	13,3	2 260	2 890	13,3	51	39	34	1200W (2R)	
	MS	4,6	15	460	2 950	10,8	2 610	2 010	10,8	48	36	30		6,8
	LS	3	6	290	2 110	6,1	1 910	1 400	6,3	38	26	19		7,7

### 4-tube

Model	Speed	Voltage	Input Power	Air flow	Heating capacity	Pressure drop heating	Cooling capacity		Pressure drop cooling	Lw	LP	Comfort level (ISO or NR)
		v	W	m <sup>3</sup> /h	W	kPa	Total W	Sensible W	kPa	dB(A)	dB(A)	
42KY20D-----	HS		45	420	2 400	17,0	2 050	1 800	9,9	51	39	34
	MS		41	360	2 200	15,0	1 870	1 580	8,4	47	35	30
	LS		34	215	1 700	10,0	1 420	1 090	5,1	35	23	18
42KY29D-----	HS	4,9	17	420	2 400	17,0	2 040	1 790	9,7	51	39	34
	MS	4,2	12	360	2 200	15,0	1 870	1 590	8,2	47	35	30
	LS	2,5	5	215	1 700	10,0	1 420	1 090	4,8	35	23	18
42KY30D-----	HS		77	660	3 000	22,0	3 833	3 009	19,2	58	46	40
	MS		56	525	2 600	17,0	3 169	2 442	13,4	51	39	34
	LS		40	405	2 200	14,0	2 600	1 955	9,3	45	33	27
42KY39D-----	HS	5,3	21	525	2 600	18,0	2 260	2 890	13,2	51	39	34
	MS	4,6	15	460	2 400	15,0	2 610	2 010	10,8	48	36	30
	LS	3	6	290	1 900	12,0	1 910	1 400	5,9	38	26	19

### EUROVENT Conditions

- Cooling mode: water temperature: 7/12°C, inlet air temperature: 27°C - 19°C (WB)
- Heating mode (2T): water temperature: 45°/40°C, inlet air temperature: 20°C
- Heating mode (4T): water temperature: 65°/55°C, inlet air temperature: 20°C
- The sound pressure levels (Lp) and ISO NR level are based on hypothetical attenuation of the room of 12 dB(A)

## TECHNICAL SPECIFICATIONS

### Coil capacity (L)

42KY cassette		10/19	20/29	30/39
2-tube coil		0,4	0,8	1,1
2-tube coil + electric heater		-	0,6	1
4-tube coil	Cooling	-	0,6	1
	Heating	-	0,2	0,2

### Diameters of coil couplings

Coil connection type: flush fit female threaded union nuts

Valve connection type: install flush fit male threaded unions

42KY cassette		10/19	20/29	30/39
2-tube coil		G 1/2"	G 1/2"	G 1/2"
2-tube coil + electric heater		-	G 1/2"	G 1/2"
4-tube coil	Cooling	-	G 1/2"	G 1/2"
	Heating	-	G 1/2"	G 1/2"

### Motor electrical specifications

42KY	Motor information	AC asynchronous motor			LEC motor		
		10	20	30	19	29	39
Input power (W)	V5	70	70	101	38	38	56
	V4	45	45	77	17	17	38
	V3	41	41	56	12	12	21
	V2	38	38	47	8	8	15
	V1	34	34	40	5	5	11
Input current (A)	V5	0,30	0,30	0,32	0,18	0,18	0,40
	V4	0,21	0,21	0,29	0,09	0,09	0,28
	V3	0,19	0,19	0,24	0,07	0,07	0,17
	V2	0,18	0,18	0,22	0,04	0,04	0,13
	V1	0,17	0,17	0,21	0,02	0,02	0,10

**NB:** Specifications given for a 230 V +/-10% - 50 Hz power supply.

- For operation at 60Hz, the power input and rotation speed values are generally higher.

- Motor operating range: min. return T°C: 0°C, max. return T°C: 40°C Unit information plate

The information plate shows all the information needed to identify the unit and its configuration. This plate is placed on the technical side that has all the connections, above the fresh air inlet.

- ① Code
- ② Serial number
- ③ Description of the unit
- ④ Rated motor power
- ⑤ Motor rotation speed
- ⑥ Coil type
- ⑦ Wiring diagram reference
- ⑧ Motor speed wiring
- ⑨ Maximum service pressure
- ⑩ Electric heater specifications (if fitted).
- ⑪ EC declaration number

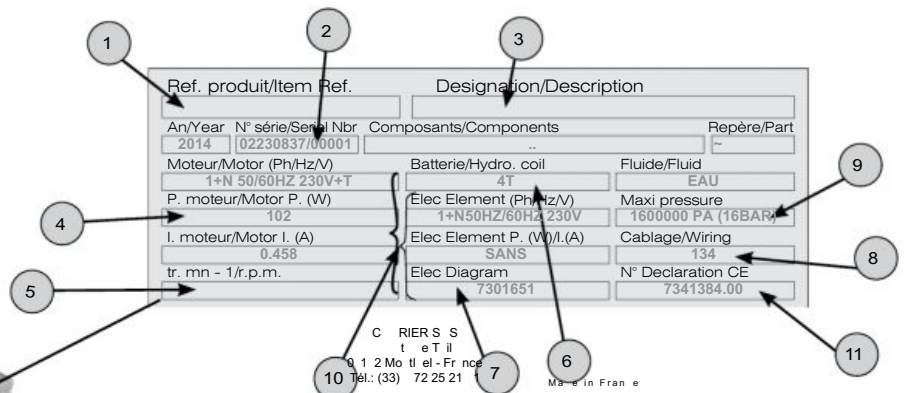
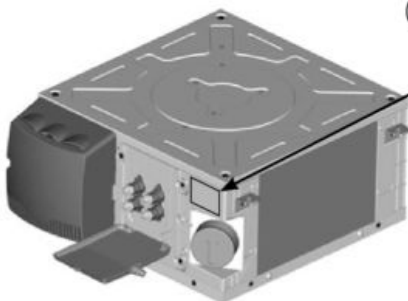

## TECHNICAL SPECIFICATIONS

### Electrical heaters

2 single-tube 230/1/50 electrical elements inserted into the aluminium housing and bent around the hydraulic coil.

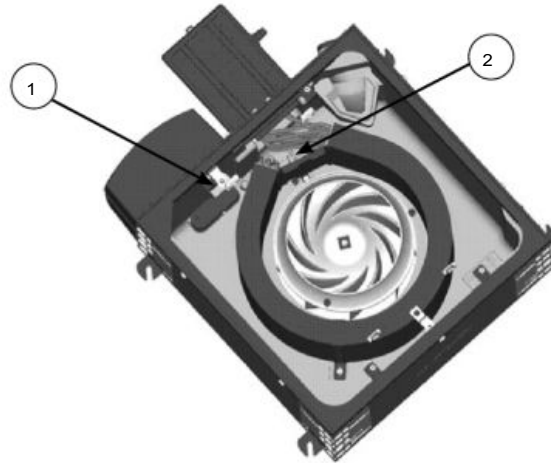

Remove shunt to deactivate a heater (reduction of 300w)

- ① Temperature limiter with manual reset
- ② Temperature limiter with automatic reset

### Electrical heater specifications - Input voltage 230V - 1 ph - 50Hz

42KY cassette	10/19	20/29	30/39
Electrical power (W)	-	900	1200
Input current (A)	-	3,6	4,8

### Limitations of use

42KY cassette	Operating pressure max. 16 Bar	Minimum water inlet temperature: 6°C
		Maximum water inlet temperature:
		4-tube coil: 80°C
		2-tube coil: 70°C
Indoor temperature	-	Minimum temperature: 5°C
	-	Maximum temperature: 40°C
Power supply	Nominal usage limitations	Min 207 - Max 253 V for units without electrical heater
		Min 216 - Max 244 V for units with electrical heater

## OPTIONS (FACTORY ASSEMBLED)

### Condensate drain pump

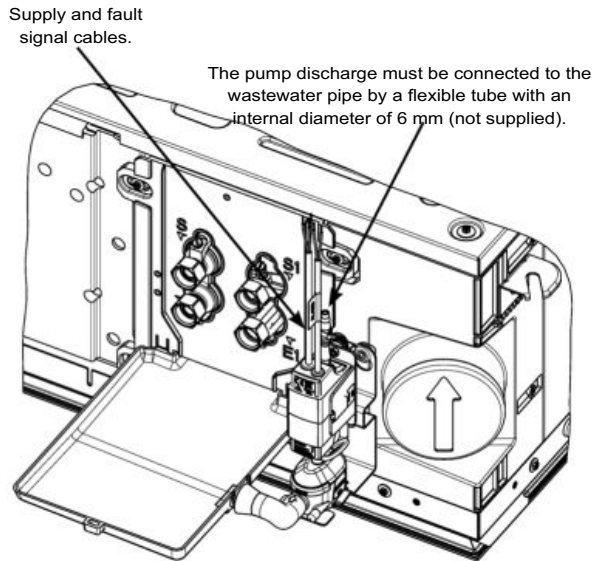

<b>Maximum flow rate</b>	10,4 l/h
<b>Maximum discharge height</b>	7 m (flow rate 4 l/h)
<b>Maximum pressure</b>	10 m (flow rate 0 l/h)
<b>Sound level at 1 m in accordance with EN ISO 3744 and 4871 (measurements taken at LNE, pump in water, outside of application)</b>	20,2 dBA
<b>Power supply</b>	230V +10%/-15% - 50/60Hz - 19W
<b>Electric insulation class</b>	Class 1
<b>Detection levels</b>	ON: 14,7 mm, OFF: 10,7 mm, AL: 17 mm
<b>Safety switch</b>	NF: 5A resistance - 250V AgNI 90/10 gold-plated contacts.
<b>Thermal protection (overheating)</b>	70°C (automatic restart)
<b>Operating cycle (operating factor)</b>	100%
<b>Protection (as per NF EN 60529)</b>	IP64
<b>Safety standard</b>	CE
<b>RoHS directive</b>	Compliant
<b>WEEE directive</b>	Compliant

Pump performance Water flow in litres per hour (-15% / +20%)				
Discharge height	Horizontal length of the discharge pipe			
	5 metres	10 metres	20 metres	30 metres
1 metre	10,4	9,1	8,3	7,3
2 metres	8,5	7,8	7	6,4
3 metres	7,9	7,1	6,3	5,8
4 metres	7	6	5,3	4,9

Operating limit:

Drain: flexible tube int. Ø 6 mm, end piece Ø 8.8 mm. This accessory must be paired with a valve control to allow the upper safety limit to control the valve's closure (stopping condensate).

Condensate flow rate (l/h) =

$$\frac{\text{Total capacity} - \text{Sensible capacity (W)}}{680}$$

680

### Accessories (available separately)

Description	
Condensate drain pump kit	
Elastic dampers (4 per device)	
Lift kit	
Self adjusting module kit, diameter 100 mm	15/30/45 m <sup>3</sup> /h
	60/75/90 m <sup>3</sup> /h
AN adapter kit, diameter 100/125 mm	
Frame kit for suspended ceiling 675x675	
LEC motor speed control 3 speed ON/OFF unit kit (only for thermostat or controllers not from CARRIER that have 3 x 230V speed outputs)	

Description	
Condensate drain pump	
Lift kit	
Frame for 675 x 675 suspended ceiling tiles	
Finishing trim frame for STAFF ceilings	
Hydraulic coil with protected blades	



## 4-WAY CASSETTE



- Easy installation
- Centralised diffusion
- Low energy consumption
- Optimised comfort
- Aesthetically integrated into suspended ceilings
- Quiet operation

## 42GW

Rated cooling capacity 1,5 - 9,5 kW  
Rated heating capacity 1,3 - 11,3 kW

Carrier's Idrofan cassettes 42GW\_AC/LEC offer a modern solution for a host of commercial applications. They are particularly suitable for big offices, stores, restaurants, bars, hotel receptions, meeting rooms, banks, laboratories and exhibition rooms.



CARRIER participates in the ECP programme for FC-FCP  
Check ongoing validity of certificate:  
[www.eurovent-certification.com](http://www.eurovent-certification.com)



## CODING

Product ref.	Range				size & motor type			Coil type	Control	Valves	Electric heater	Valve servomotors	Elec. box
	4	2	G	W	2	0	0	C	A	G	A	A	-
Digit	1	2	3	4	5	6	7	8	9	10	11	12	13

## Digit 8

C = 2-pipe

D = 4-pipe

## Digit 5 - 6 - 7

2	0	0	AC motor
2	0	9	EC motor
3	0	0	AC motor
3	0	9	EC motor
4	0	0	AC motor
4	0	9	EC motor
5	0	0	AC motor
5	0	9	EC motor
6	0	0	AC motor
6	0	9	EC motor
7	0	1	AC motor
7	0	9	EC motor

## Digit 10

- = No valves

G = 2-way valve

H = 4-way valve

## Digit 11

- = None

A = Elec. batt.

## Digit 13

- = Without CARRIER valve, for customer 230V ON/OFF valve

X = Without CARRIER valve, for customer 230V - 3PTS valve

Y = Without CARRIER valve, for customer 24V - 3PTS valve

Z = Without CARRIER valve, for customer 24V ON/OFF valve

## Digit 12

- = None

A = 230 V ON/OFF actuator

B = 24V ON/OFF servomotor (mandatory, digit 9 = -)

C = 3-POINT 230 V actuator (with NTC or WTC)

B = 24V 3-POINT servomotor (mandatory, digit 9 = -)

## Digit 9

- = None

A = 33TA Thermostat for AC motor (2-PIPE)

B = 33TB Thermostat for AC motor (4-pipe or 2-pipe + elec.)

C = 33TC Thermostat for EC motor (2-pipe)

D = 33TD Thermostat for EC motor (4-pipe or 2-pipe + elec.)

K = NTC control (AQUASmart EVOLUTION®)

L = WTC LON control (manual louvres grille, without IR)

M = WTC BACNET control (manual louvres grille, without IR)

P = WTC LON control (grille with manual louvres and IR receiver)

Q = WTC BACNET control (grille with manual louvres and IR receiver)

## TECHNICAL DESCRIPTION

- The 42GW\_AC is available with a 3-speed AC motor. The 42GW\_LEC is available with a variable speed low energy consumption (LEC) motor.
- The 42GW is installed in suspended ceilings, and can provide two, three or four-way diffusion. These units maintain the requisite temperature and humidity degree with precision, while preventing draughts and formation of areas of stagnant air.
- The air inlet grille blends in nicely with all types of interior.
- Carrier's hydraulic cassette is available in 6 sizes, to suit a vast range of applications, with air flows ranging from 100 to 402 l/s (360 to 1450 m<sup>3</sup>/h). The Idrofan cassette offers an ultra-low noise level, for situations where low noise level is the most important selection criterion.

### General specifications

- The slimline 42GW is light and easy to install. The small frame is perfectly suited to conventional ceiling tiles, and is easy to install anywhere.
- Comfort is ensured by four-way air supply. It is possible to adjust the degree of opening on each diffuser.
- Integrated cooling and heating coils, which come factory-fitted, for two-pipe or two-pipe plus electrical heater applications, as well as 4-pipe applications.

### Designed for quiet

- 42GW units have been designed especially to operate very quietly, with noise levels which represent new comfort levels for buildings. The unique design of the centrifugal fan ensures very quiet operation.
- The new design of the fan/motor block ensures quiet operation (half the noise of the previous model). Particular attention has been paid to low-speed operation of the fan.
- The special shape of the diffuser ensures a rapid mix of supply air and ambient air. Conditioned air is blown against the ceiling, and then distributed uniformly throughout the room. The return air enters the cassette via a large grille. It is then cleaned by a removable and washable synthetic filter, conditioned and then supplied again.

### Motors

- The Idrofan is available with a three-speed AC motor, with ultra-low noise levels, which makes it one of the quietest cassettes on the market.
- The Idrofan is also available with variable speed LEC motors (low energy consumption), which meet the new building energy performance objectives. The low energy consumption solution improves the unit's performances, bringing you:
  - Lower energy costs – the LEC motor reduces the unit's energy consumption by 50 to 70%. This option meets the new regulations in terms of building energy management.
  - Better comfort – the variable speed low energy consumption motor reduces the noise level compared to multi-speed motors, making for an ultra-quiet air flow, even at very low operating levels. Thanks to the NTC control, a maximum fan speed can be set to better manage noise level.
  - Maximum flexibility – the air flow automatically adapts from 0 to 100%, ensuring perfect cooling or heating conditions in the room.
  - Extended service life – low energy consumption LEC technology motors run at lower fan motor temperatures, which extends their service life.

### Filters

- The standard filter used for the Idrofan range has a pleated filtration surface, which provides a surface area 87% larger than a traditional filter, as well as the following additional advantages:
  - Low pressure drop, consumption and noise level.
  - The mean filter cleaning interval is three times longer than for standard filters.
  - EU1 grade polypropylene-based filter.
- In the Idrofan cassette range, the filter is situated in the unit's grille. Cleaning is simple: you need only detach the filter manually from the support on the grille. The filter frame can be lowered, and the filter can be easily removed. Refitting is just as simple, you need only follow the procedure in reverse. Washable filters are supplied in the standard version.



### Condensate drain pump

- Self-contained, very high-performance condensate drain pump flush-mounted in soundproofing material, for better condensate management - quick and quiet.
- The cassette's main condensate pan has been improved thanks to use of the very latest composite materials, to provide better noise absorption, easier cleaning and better condensed water transfer from the coil to the discharge pump.

## TECHNICAL DESCRIPTION

### Electrics box

- All the units are equipped with an electrics box, which contains the terminal strips. This box is located on the outside of the unit. The box cover is easy to open: you need only remove a mounting bolt. For more details on the electrical connections, please consult the appropriate wiring prints.



### Carrier controllers range

- The Idrofan is available with the complete range of Carrier controllers. Several types facilitate installation. The number of controllers offers an abundance of solutions and makes selection easy, according to its application.
  - A-B-C-D type electronic thermostats
  - The Carrier electronic thermostats range is available for all Carrier hot water terminal ranges
  - Type A: a two-pipe application equipped with alternating current motors
  - Type B: four or two-pipe applications equipped with electric heating and alternating current motors.
  - Type C: a two-pipe application equipped with EC motors
  - Type D: four or two-pipe applications equipped with electric heating and EC motors.
- The thermostat for FCU with EC motors option manages 3 intermittent and configurable speeds, via a 0-10V signal.
- The thermostats come in an elegant square shape with a coaxial button enabling the room temperature to be set, as well as three buttons for setting the ventilation speed, cooling or heating mode, and START or STOP mode, as the customer wishes.
- Wall-mounted controls can easily and discreetly be integrated into any room environment.
- The operating range of the electronic thermostats goes from 10°C to 30°C, with the option of limiting the temperature in public buildings where low energy consumption is a paramount requirement. This is done via a micro-switch which is inside the control (cooling setpoint between 23°C and 30°C, heating between 10°C and 21°C).

The following characteristics are available as parameters:

- **Auto ventilation:** the fan speed is automatically set by the thermostat; when the ambient temperature drifts away from the setting, maximum speed is selected. When the ambient temperature nears the desired value, the speed decreases until reaching minimum speed or stopping in the deadband.
  - **Automatic changeover:** automatic changeover from cooling mode to heating mode, depending on the water temperature, ensures that the ideal ambient temperature is maintained.
  - **Remote changeover:** automatic changeover from cooling mode to heating mode, depending on the remote signal emitted by the control system.
  - **Draught protection:** this function stops the fan if the water temperature is too low or too high in relation to demand, thereby ensuring that the room's occupants are not disturbed by a warm draught.
  - **Air temperature sensor:** this sensor is mounted on the unit. If the thermostat is installed on a wall, a second sensor situated in the thermostat may be used to correctly set the desired ambient temperature.
  - **Low water temperature cutout:** this function ensures that the ambient temperature is maintained above the minimum level. If the unit has been shut down and ambient temperature has dropped below 7°C, low water temperature cutout is activated and the unit operates in heating mode until the temperature reaches above 9°C. The unit is then switched off again.
  - **Optimised heating management (available with the electrical heater option):** if the water temperature is below 30°C, the system operates in heating demand mode, and the electrical heater is the only available heating source. If the water temperature is above 35°C, the system operates in auxiliary heating mode, powering up the water coil and electrical heater at the same time. The auxiliary heating function is deactivated if the temperature reaches above 45°C (the electrical heater is then de-energized).
  - **Unoccupied mode:** this temperature function saves energy when the room is unoccupied, without needing to switch off the unit. When the unoccupied mode button is held down, the current setpoint is modified as follows, without changing the position of the setpoint selection button:
    - Cooling: setpoint increased by 4 K
    - Heating: setpoint decreased by 4 K
- The unit reverts to normal operation when the unoccupied mode button is held down again.
- **LED intensity:** for office applications or light commercial applications, 10 seconds after the user interface has last been used, all the necessary LEDs are dimmed. As soon as the user touches the user interface again, the LEDs revert to normal brightness. To prevent disruption to hotel customers, the thermostat can be configured from Night Mode to Dark Mode: in this case, 10 seconds after the user interface has last been used, all the LEDs will switch off. As soon as the user touches the user interface again, the current status LEDs will switch on, and revert to normal brightness.

## TECHNICAL DESCRIPTION

- **Air sampling:** if no ventilation demand is made and the air sampling jumper is in the ON position, the command executes the air sampling function: the air moves, to ensure a more reliable ambient temperature reading.
- **Continuous ventilation:** if there is no ventilation demand and the continuous ventilation jumper is in the ON position, the control selects low, medium or high fan speed, depending on the ventilation speed selection, regardless of the thermal conditions. If the fan is controlled by automatic ventilator mode and the control is not in demand phase, the fan is activated permanently in low speed mode.
- **External contact:** a high voltage input signal for external contact is displayed. If the external contact is activated, the device will respond according to its local configuration:
  - Presence detection (empty room with a hotel door card), energy saving mode is activated, the internal temperature is increased by 4°C in cooling mode and is decreased by 4°C in heating mode
  - Window contact: during STOP mode (window open), all the outputs are disconnected (fan, valves, etc.), and only the frost protection function is active if it has been started up via its micro-switch.
- **Master/slave control:**
  - Thermostat type A\_AC and B\_AC: the accessories grouped control panel (42N9006) provides a ventilation speed relay only (the water valves must be wired or related separately) for up to 300 units with air temperature-based control (no water valves), or for 10 two-pipe units with water control, or 5 four-pipe units with water control
  - Thermostat type C\_EC and D\_EC: the EC motor thermostat version can control up to 10 LEC units thanks to parallel wiring of the analogue output signal with two 0-10 cables (the water valves and electric heaters must be wired or relayed separately).

### NTC

- A PID controller can communicate and combine energy savings algorithms with solutions providing complete control functions, compatible with the Aquasmart Evolution system. The NTC control is compatible with the low energy consumption motor option, and combines energy savings with optimised comfort.

### Valve types available

- Valve bodies: both types of valve, two-way or four-way (three-way with integral by-pass) are factory-fitted and subjected to factory tests. These chilled water valves are completely insulated in a moulded insulant jacket, which prevents condensation from forming on the valve body. This new jacket reduces the complexity of the range and prevents the risk of water leaks. These valves can be factory-fitted on the unit side.

### WTC controller

- Open Communication protocol BACnet or LON
- Communication PID controller
- Large range of user interfaces, wall mounted or remote
- Manages the EC motor for optimised comfort
- Manages a CO<sub>2</sub> sensor to improve air quality
- Optional lighting and/or blinds management modules, controlled from the same user interface
- Large range of sensors (light, presence, etc.)

### Valve types available

- Valve bodies: both types of valve, two-way or four-way (three-way with integral by-pass) are factory-fitted and subjected to factory tests. These chilled water valves are completely insulated in a moulded insulant jacket, which prevents condensation from forming on the valve body. This new jacket reduces the complexity of the range and prevents the risk of water leaks. These valves can be factory-fitted on the unit side.



Insulating moulded jacket for the valve

## TECHNICAL DESCRIPTION

- Valve actuators: Carrier has a vast range of valve actuators with two or four-way valve bodies, which offer the most suitable solution whatever the control type and the customer's requirements, from on/off to proportional type, and a 230 V or 24 V power supply:
  - 230 V on/off actuator
  - 24 V on/off actuator
  - 230 V 3-point floating actuator
  - 24 V 3-point floating actuator
- When combining low energy consumption motors with an NTC control, it is recommended to use 230 V three-point floating actuators, to increase energy savings and improve comfort.

### Auxiliary condensate pan

- An auxiliary condensate pan is available as an accessory if the water valves, shut-off valves or balancing valves are customer supplied. Conversely, the auxiliary condensate pan is not required if you have water valves factory-fitted by Carrier, since they come supplied with an insulated valve body (insulating moulded jacket), which prevents condensation.\*



Auxiliary drain pan for units 42GW\_S/E 200/209, 300/309, 400/409



Auxiliary drain pan for units 42GW\_S/E 500/509, 600/609, 701/709

### Electrical heater option

- There is an electrical heater option only on models with a two-pipe coil. There is an electrical heater available for each Idrofan cassette size, factory-fitted to ensure reliable and completely safe operation.

### Fresh air inlet option

- All the units have couplings provided for fresh air inlet ducts, which can considerably improve the indoor air quality, while the fresh air intake volume is regulated by the CO<sub>2</sub> sensor by means of the NTC control.
- The fresh air flow must represent less than 10% of the total air flow, to prevent operating problems and excessive noise. For a higher air flow, there is a primary air kit which can be fitted on the pre-cut hole provided for an air duct in the adjacent room, and a noise barrier, such that the fresh air enters the room via a diffuser.

### Conditioned air supply via a duct in an adjacent room

- This option supplies conditioned air in a room situated near the Idrofan cassette, via an air duct (customer supplied). If this option is used, the supply air opening corresponding to the duct must be closed, using the air discharge outlet closing kit supplied. This kit cannot be used in units fitted with an electrical heater. An air inlet grille must be fitted (if possible near the floor) between the air conditioned room (where the unit is) and the adjacent room; or a cut-out can be made at the bottom of the door.
- The duct lengths can be calculated in accordance with the "air distribution in an adjacent room" diagram, which figures in the installation, operation and maintenance manual, also taking into account the pressure drop via the air diffusers and the fresh air filters.

### Ease of maintenance

- All of the main components (motors, fans and discharge pump) are accessible from the unit base; you need only remove the grille. These components can also be removed without having to touch the other components or removing the surrounding ceiling tiles.



## PHYSICAL AND ELECTRICAL SPECIFICATIONS, UNITS WITH AC MOTORS

42GW	200C			300C			400C			500C			600C			701C					
Coil type	2-pipe			2-pipe			2-pipe			2-pipe			2-pipe			2-pipe					
Fan speed <sup>(1)</sup>	1	2	3	1	2	3	1	2	3	1	2	3	1	2	3	1	2	3			
Air flow	l/s			183	125	100	204	140	89	249	173	134	272	199	147	321	229	139	402	299	166
	m <sup>3</sup> /h			660	450	360	735	505	320	900	625	485	980	720	530	1160	825	500	1450	1080	600
<b>Cooling</b>																					
Total cooling capacity	kW			2,33	1,74	1,53	3,96	2,86	1,86	4,64	3,46	2,77	6,03	4,41	3,33	7,13	5,43	3,68	8,54	6,43	4,02
Sensible cooling capacity	kW			1,95	1,46	1,28	3,01	2,16	1,41	3,57	2,64	2,11	4,68	3,44	2,58	5,37	4,03	2,66	6,4	4,81	2,95
Water flow	l/s			0,11	0,09	0,08	0,19	0,14	0,09	0,23	0,17	0,13	0,29	0,21	0,16	0,34	0,26	0,18	0,41	0,31	0,19
	l/h			410	310	270	690	500	320	810	600	480	1050	760	580	1240	940	640	1490	1120	700
Water pressure drop, cooling	kPa			11,1	6,8	5,6	15,2	8,6	4,7	19,8	11,6	7,9	23,8	13,4	8,3	12,4	7,8	4,6	21,9	13,1	6
<b>Heating mode</b>																					
Heating capacity	kW			2,74	2,17	1,92	3,68	3,15	1,94	5,28	3,92	3,16	6,84	5,08	3,8	8,51	6,26	3,85	10,28	7,95	4,38
Water flow	l/s			0,13	0,11	0,09	0,18	0,15	0,09	0,26	0,19	0,15	0,33	0,24	0,18	0,41	0,30	0,19	0,50	0,38	0,21
	l/h			480	380	330	640	550	340	920	680	550	1190	880	660	1480	1090	670	1790	1380	760
Water pressure drop, heating	kPa			11,8	8,4	7,1	12,8	10,1	5,0	18,6	11,7	8,4	23,1	14,4	9,2	15,3	9,6	4,8	18	11	5
Water volume	l			0,55			1,1			1,1			1,6			2,4			2,4		
<b>Sound levels</b>																					
Sound power level	dB(A)			49	41	37	53	47	35	57	48	42	49	40	35	54	46	38	59	52	40
Sound pressure level	dB(A)			40	32	28	44	38	26	48	39	33	40	31	26	45	37	29	50	43	31
NR value <sup>(2)</sup>				36	28	25	40	31	20	43	34	28	35	26	21	40	32	22	45	38	25
Power input	W			58	35	25	58	34	17	99	58	38	66	41	28	88	61	34	125	92	44
Current	A			0,27	0,17	0,12	0,24	0,14	0,07	0,41	0,24	0,16	0,30	0,17	0,12	0,46	0,27	0,14	0,63	0,41	0,19
EUROVENT FCEER energy class (cooling mode)				D			C			D			C			C			D		
EUROVENT FCCOP energy class (heating mode)				E			D			D			C			C			D		
<b>Electrical heater</b>																					
High capacity @240V	W			1500			2500			2500			3000			3000			3000		
Current (high capacity) @240V	A			6,3			10,4			10,4			12,5			12,5			12,5		
Coil connection diameter	inches			3/4 " gas			3/4" gas			3/4 " gas			1" gas			1" gas			1" gas		
Condensate diameter	mm			16			16			16			16			16			12,5		
Weight, unit	kg			14,8			16,5			16,5			37			39,6			39,6		
Weight, grille	kg			3			3			3			5			5			5		

**Based on Eurovent conditions:**

Cooling mode (2 and 4-pipe coils): entering air temperature 27°C dry bulb/19°C wet bulb, 7°C/12°C entering and leaving water temperature

Heating mode (2-pipe coil): air temperature 20°C, 45°C/40°C entering and leaving water temperature

Heating mode (4-pipe coil): air temperature 20°C, 65°C/55°C entering and leaving water temperature

(1) Speeds: 1 = high, 2 = medium, 3 = low

(2) Sound pressure level and NR values with hypothetical noise attenuation of the room of -9 dB(A).

**Note: the version with an electrical heater is available on all 2-pipe units**

Eurovent certified values

## PHYSICAL AND ELECTRICAL SPECIFICATIONS, UNITS WITH AC MOTORS

42GW		200D			300D			400D			600D			701D		
Coil type		4-pipe			4-pipe			4-pipe			4-pipe			4-pipe		
Fan speed <sup>(1)</sup>	l/s	1	2	3	1	2	3	1	2	3	1	2	3	1	2	3
Air flow	m <sup>3</sup> /h	183	125	100	204	140	89	249	173	134	321	229	139	402	299	166
		660	450	360	735	505	320	900	625	485	1160	825	500	1450	1080	600
<b>Cooling</b>																
Total cooling capacity	kW	1,97	1,49	1,34	3,34	2,67	1,98	3,95	3,18	2,53	6,58	4,93	2,96	7,49	5,97	3,14
Sensible cooling capacity	kW	1,84	1,37	1,18	2,62	2,05	1,49	3,25	2,55	2,04	5,08	3,78	2,31	5,89	4,64	2,53
	l/s	0,10	0,07	0,06	0,17	0,13	0,10	0,20	0,16	0,12	0,32	0,24	0,14	0,39	0,32	0,18
Water flow	l/h	350	260	230	580	460	340	700	560	440	1140	860	510	1310	1040	550
Water pressure drop, cooling	kPa	14,9	9,1	7,6	12,6	8,6	5,6	16,5	11,2	7,6	25,2	15,3	6,5	31,5	21,8	7,1
Water volume, cooling	l	0,4			1,1			1,1			2,4			2,4		
<b>Heating mode</b>																
Heating capacity	kW	1,67	1,27	1,09	5,46	4,4	3,1	5,8	5	4,32	10,04	7,79	5,28	12,77	10,07	6,43
	l/s	0,04	0,03	0,03	0,15	0,12	0,09	0,16	0,14	0,12	0,27	0,21	0,14	0,35	0,27	0,17
Water flow rate	l/h	150	110	100	548	439	310	585	499	430	989	765	516	1247	989	628
Water pressure drop, heating	kPa	29,5	18,8	14,8	21,1	14,8	8,5	24,2	18,9	15	12,3	8,4	5,1	17,9	12,3	6,5
Water volume	l	0,1			0,6			0,6			1,2			1,2		
<b>Sound levels</b>																
Sound power level	dB(A)	49	40	36	53	44	35	57	48	42	54	46	38	59	52	40
Sound pressure level	dB(A)	40	31	27	44	35	26	48	39	33	45	37	29	50	43	31
NR value <sup>(2)</sup>		35	27	23	39	30	20	43	34	28	40	32	22	45	38	25
Power input	W	58	35	25	58	34	17	99	58	38	88	61	34	125	92	44
Current	A	0,27	0,17	0,12	0,24	0,14	0,07	0,41	0,24	0,16	0,46	0,27	0,14	0,63	0,41	0,19
EUROVENT FCEER energy class (cooling mode)		E			C			D			C			D		
EUROVENT FCCOP energy class (heating mode)		E			C			D			C			C		
<b>Connection diameter</b>																
Cooling coil	inches	3/4 " gas			3/4 " gas			3/4 " gas			1" gas			1" gas		
Heating coil	inches	1/2 " gas			1/2 " gas			1/2 " gas			3/4 " gas			3/4 " gas		
Condensate diameter	mm	16			16			16			16			16		
Unit weight	kg	14,8			16,5			16,5			39,6			39,6		
Grille weight	kg	3			3			3			5			5		

### Based on Eurovent conditions:

Cooling mode (2 and 4-pipe coils): entering air temperature 27°C dry bulb/19°C wet bulb, 7°C/12°C entering and leaving water temperature

Heating mode (2-pipe coil): air temperature 20°C, 45°C/40°C entering and leaving water temperature

Heating mode (4-pipe coil): air temperature 20°C, 65°C/55°C entering and leaving water temperature

(1) Speeds: 1 = high, 2 = medium, 3 = low

(2) Sound pressure level and NR values with hypothetical noise attenuation of the room of -9 dB(A).

**Note: the version with an electrical heater is available on all 2-pipe units**



Eurovent certified values

## PHYSICAL AND ELECTRICAL SPECIFICATIONS, UNITS WITH AC MOTORS

42GW	209C			309C			409C			509C			609C			709C			
Coil type	2-pipe			2-pipe			2-pipe			2-pipe			2-pipe			2-pipe			
Fan speed <sup>(1)</sup>	1	2	3	1	2	3	1	2	3	1	2	3	1	2	3	1	2	3	
Voltage (DC)	V	10	6	2	10	6	2	10	6	2	10	6	2	10	6	2	10	6	2
Air flow	l/s	183	125	100	204	140	89	249	173	134	272	199	147	321	229	139	443	299	166
	m <sup>3</sup> /h	660	450	360	735	505	320	900	625	485	980	720	530	1160	825	500	1600	1080	600
<b>Cooling</b>																			
Total cooling capacity	kW	2,36	1,77	1,54	3,98	2,88	1,87	4,68	3,5	2,79	6,08	4,44	3,35	7,19	5,47	3,71	9,55	6,49	4,05
Sensible cooling capacity	kW	1,98	1,49	1,29	3,04	2,18	1,42	3,61	2,67	2,13	4,72	3,47	2,6	5,43	4,07	2,68	7,16	4,86	2,98
Water flow rate	l/s	0,11	0,09	0,08	0,19	0,14	0,09	0,23	0,17	0,13	0,29	0,21	0,16	0,34	0,26	0,18	0,46	0,31	0,19
	l/h	410	310	270	690	500	320	810	600	480	1050	760	580	1240	940	640	1660	1120	700
Water side pressure drop, cooling	kPa	11,1	6,8	5,6	15,2	8,6	4,7	19,8	11,6	7,9	23,8	13,4	8,3	12,4	7,8	4,6	26,9	13,1	6
<b>Heating mode</b>																			
Heating capacity	kW	2,74	2,17	1,92	3,68	3,15	1,94	5,28	3,92	3,16	6,84	5,08	3,8	8,51	6,26	3,85	11,03	7,95	4,38
Water flow	l/s	0,13	0,11	0,09	0,18	0,15	0,09	0,26	0,19	0,13	0,33	0,24	0,18	0,41	0,30	0,19	0,53	0,38	0,21
	l/h	480	380	330	640	550	340	920	680	480	1190	880	660	1480	1090	670	1920	1380	760
Water pressure drop, heating	kPa	11,8	8,4	7,1	12,8	10,1	5	18,6	11,7	8,5	23,1	14,4	9,2	15,3	9,6	4,8	30,6	18	7,2
Water volume	l	0,55			1,1			1,1			1,6			2,4			2,4		
<b>Sound levels</b>																			
Sound power level	dB(A)	49	40	36	53	44	35	57	48	42	49	40	35	54	46	38	61	52	40
Sound pressure level	dB(A)	40	31	27	44	35	26	48	39	33	40	31	26	45	37	29	52	43	31
NR value <sup>(2)</sup>		35	27	23	40	31	20	43	35	29	35	26	20	39	32	22	47	38	25
Power input	W	29	13	9	33	14	7	57	23	13	25	12	7	45	23	9	115	40	11
Current	A	0,19	0,1	0,08	0,27	0,13	0,08	0,46	0,2	0,12	0,23	0,12	0,08	0,4	0,22	0,1	0,89	0,35	0,12
<b>EUROVENT FCEER energy class (cooling mode)</b>		B			A			B			A			A			A		
<b>EUROVENT FCCOP energy class (heating mode)</b>		B			B			B			A			A			B		
<b>Electrical heater</b>																			
High capacity @240V	W	1500			2500			2500			3000			3000			3000		
Current (high capacity) @240V	A	6,3			10,4			10,4			12,5			12,5			12,5		
<b>Coil connection diameter</b>	inches	3/4 " gas			3/4" gas			3/4 " gas			1" gas			1" gas			1" gas		
Condensate diameter	mm	16			16			16			16			16			12,5		
<b>Weight, unit</b>	kg	14,8			16,5			16,5			37			39,6			39,6		
Weight, grille	kg	3			3			3			5			5			5		

**Based on Eurovent conditions:**

Cooling mode (2 and 4-pipe coils): entering air temperature 27°C dry bulb/19°C wet bulb, 7°C/12°C entering and leaving water temperature

Heating mode (2-pipe coil): air temperature 20°C, 45°C/40°C entering and leaving water temperature

Heating mode (4-pipe coil): air temperature 20°C, 65°C/55°C entering and leaving water temperature

(1) Speeds: 1 = high, 2 = medium, 3 = low

(2) Sound pressure level and NR values with hypothetical noise attenuation of the room of -9 dB(A).

**Note: the version with an electrical heater is available on all 2-pipe units**

Eurovent certified values

## PHYSICAL AND ELECTRICAL SPECIFICATIONS, UNITS WITH AC MOTORS

42GW		209D			309D			409D			609D			709D		
Coil type		4-pipe			4-pipe			4-pipe			4-pipe			4-pipe		
<b>Fan speed<sup>(1)</sup></b>																
Voltage (DC)	V	10	6	2	10	6	2	10	6	2	10	6	2	10	6	2
Air flow	l/s	183	125	100	204	140	89	249	173	134	321	229	139	443	299	166
	m <sup>3</sup> /h	660	450	360	735	505	320	900	625	485	1160	825	500	1600	1080	600
<b>Cooling</b>																
Total cooling capacity	kW	1,97	1,49	1,34	3,34	2,67	1,98	3,95	3,18	2,53	6,58	4,93	2,96	7,49	5,97	3,14
Sensible cooling capacity	kW	1,84	1,37	1,18	2,62	2,05	1,49	3,25	2,55	2,04	5,08	3,78	2,31	5,89	4,64	2,53
Water flow	l/s	0,10	0,07	0,06	0,17	0,13	0,10	0,20	0,16	0,12	0,32	0,24	0,14	0,36	0,29	0,15
	l/h	350	260	230	580	460	340	700	560	440	1140	860	510	1310	1040	550
Water pressure drop, cooling	kPa	14,9	9,1	7,6	12,6	8,6	5,6	16,5	11,2	7,6	25,2	15,3	6,5	31,5	21,8	7,1
Water volume, cooling	l	0,4			1,1			1,1			2,4			2,4		
<b>Heating mode</b>																
Heating capacity	kW	1,67	1,27	1,09	5,46	4,4	3,1	5,8	5	4,32	10,04	7,79	5,28	13,99	10,07	6,43
Water flow	l/s	0,04	0,03	0,03	0,13	0,11	0,08	0,14	0,12	0,11	0,24	0,19	0,13	0,31	0,24	0,16
	l/h	150	110	100	480	390	270	510	440	380	880	680	460	1120	880	560
Water pressure drop, heating	kPa	29,5	18,8	14,8	21,1	14,8	8,5	24,2	18,9	15	12,3	8,4	5,1	20,7	12,3	6,5
Water volume	l	0,1			0,6			0,6			1,2			1,2		
<b>Sound levels</b>																
Sound power level	dB(A)	49	40	36	53	44	35	57	48	42	54	46	38	61	52	40
Sound pressure level	dB(A)	40	31	27	44	35	26	48	39	33	45	37	29	52	43	31
NR value <sup>(2)</sup>		35	27	23	40	31	20	43	35	29	39	32	22	47	38	25
Power input	W	29	13	9	33	14	7	57	23	13	45	23	9	115	40	11
Current	A	0,19	0,1	0,08	0,27	0,13	0,08	0,46	0,2	0,12	0,4	0,22	0,1	0,89	0,35	0,12
EUROVENT FCEER energy class (cooling mode)		B			A			B			A			B		
EUROVENT FCCOP energy class (heating mode)		C			A			B			A			A		
<b>Connection diameter</b>																
Cooling coil	inch	3/4 " gas			3/4 " gas			3/4 " gas			1" gas			1" gas		
Heating coil	inch	1/2 " gas			1/2 " gas			1/2 " gas			3/4 " gas			3/4 " gas		
Condensate diameter	mm	16			16			16			16			12,5		
Weight, unit	kg	14,8			14,8			14,8			39,6			39,6		
Heaters weight	kg	3			3			3			5			5		

### Based on Eurovent conditions:

Cooling mode (2 and 4-pipe coils): entering air temperature 27°C dry bulb/19°C wet bulb, 7°C/12°C entering and leaving water temperature

Heating mode (2-pipe coil): air temperature 20°C, 45°C/40°C entering and leaving water temperature

Heating mode (4-pipe coil): air temperature 20°C, 65°C/55°C entering and leaving water temperature

(1) Speeds: 1 = high, 2 = medium, 3 = low

(2) Sound pressure level and NR values with hypothetical noise attenuation of the room of -9 dB(A).

**Note: the version with an electrical heater is available on all 2-pipe units**



Eurovent certified values

## DIMENSIONS, MM

### 42GW 200/209 - 300/309 - 400/409 (compact chassis)

#### Unit without valve

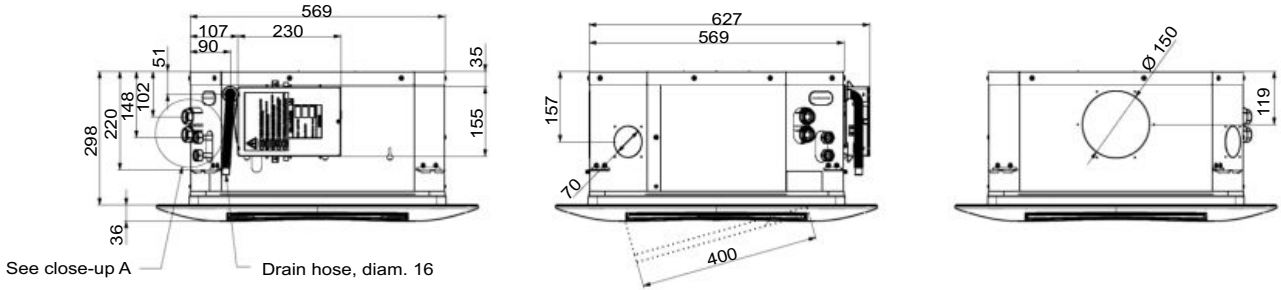

#### Close-up A

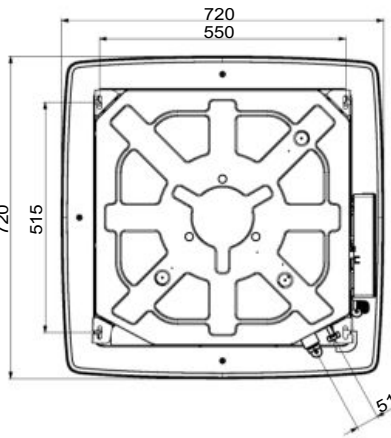
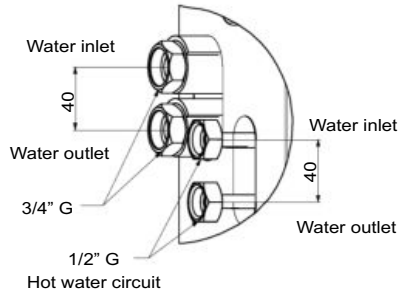

#### Unit with 2-way valve

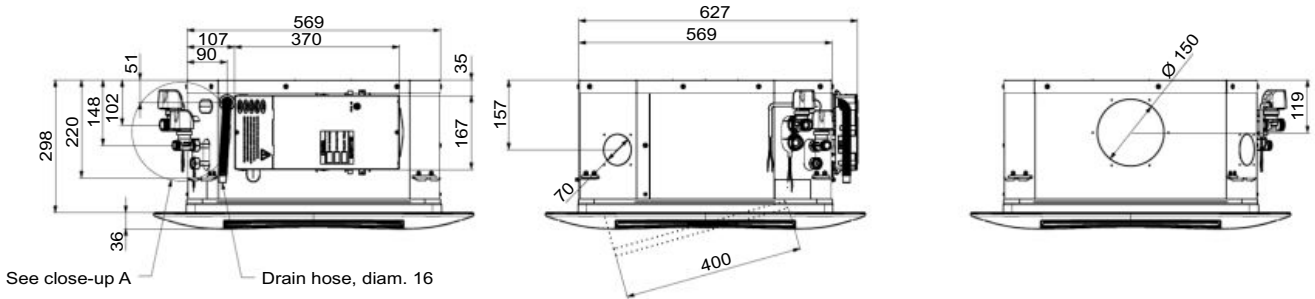

#### Close-up A

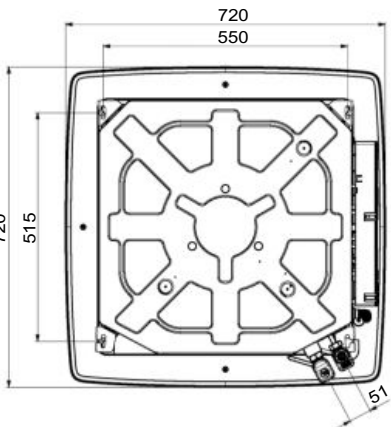
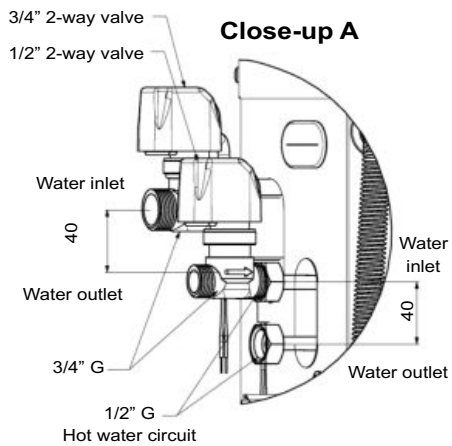



**DIMENSIONS, MM**

**42GW 200/209 - 300/309 - 400/409 (compact chassis)**

**Unit with 4-way valves**

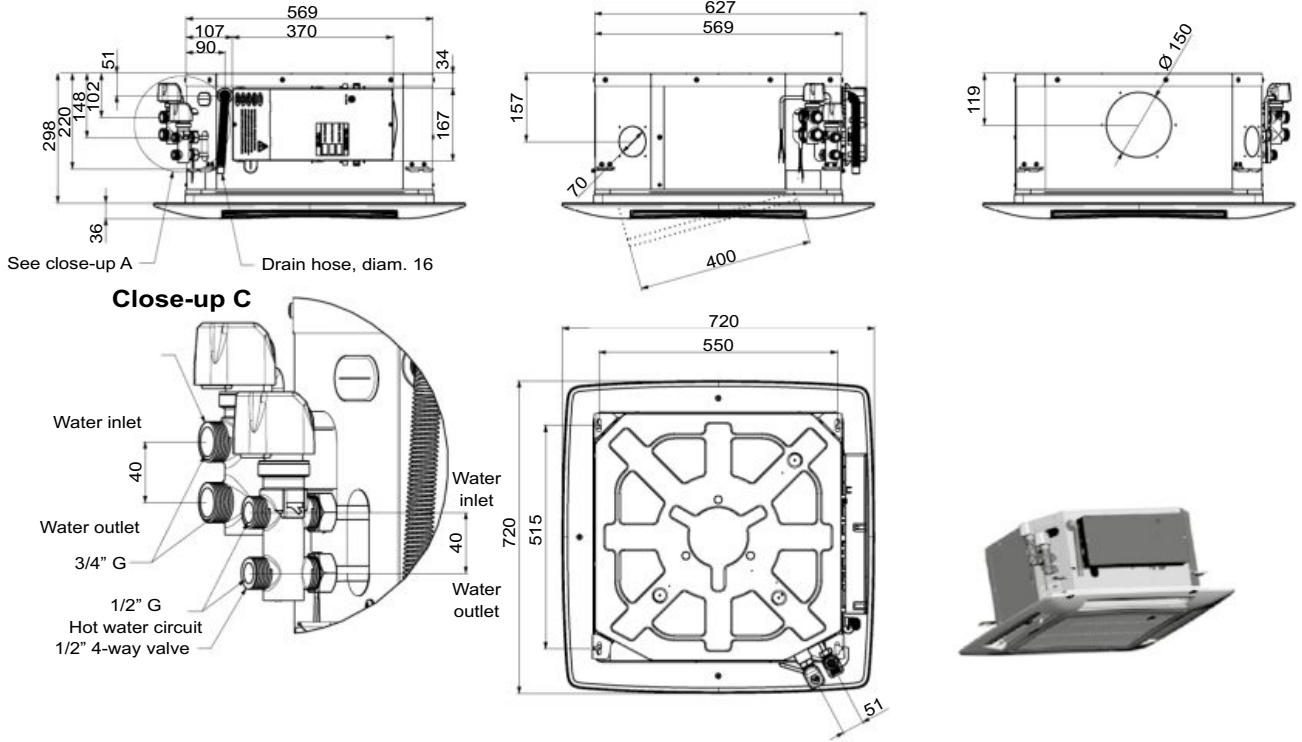

**42GW 500/509 - 600/609 - 701/709 (big chassis)**

**Unit without valve**

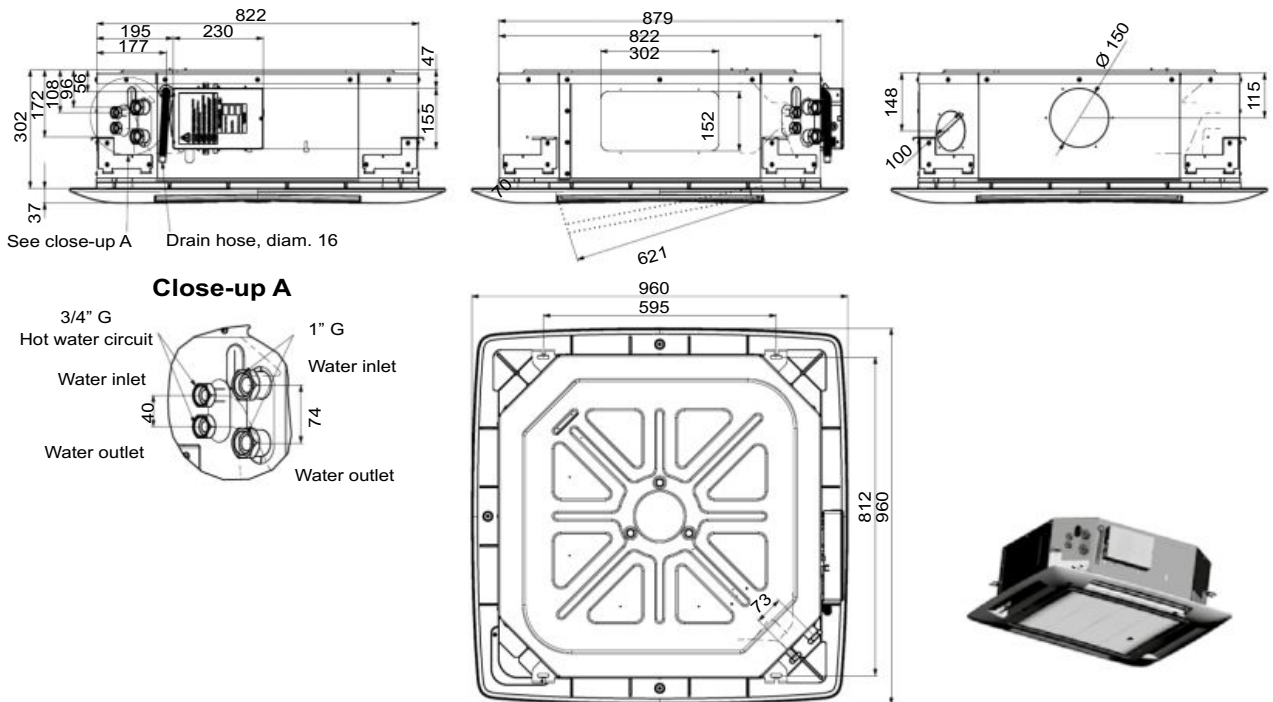

## DIMENSIONS, MM

### 42GW 500/509 - 600/609 - 701/709 (big chassis)

#### Unit with 2-way valve

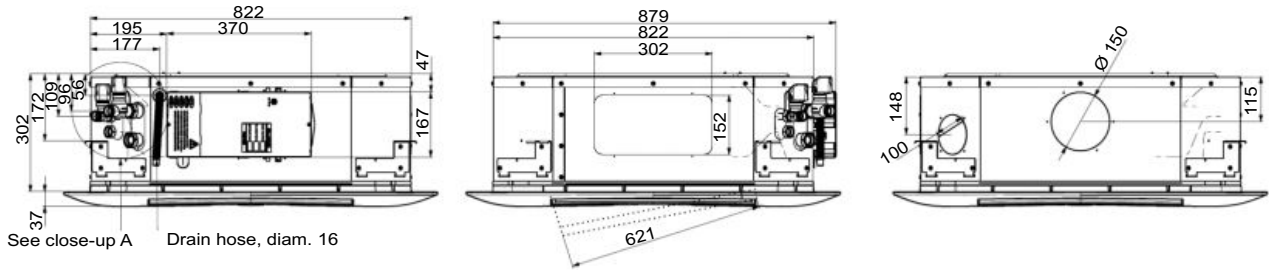

#### Close-up B

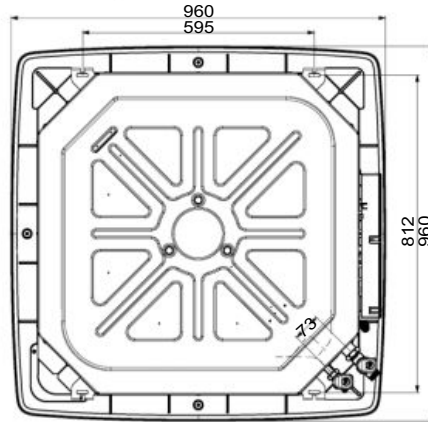
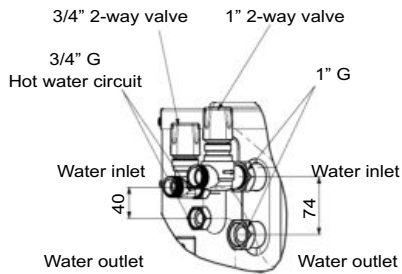

#### Unit with 4-way valve

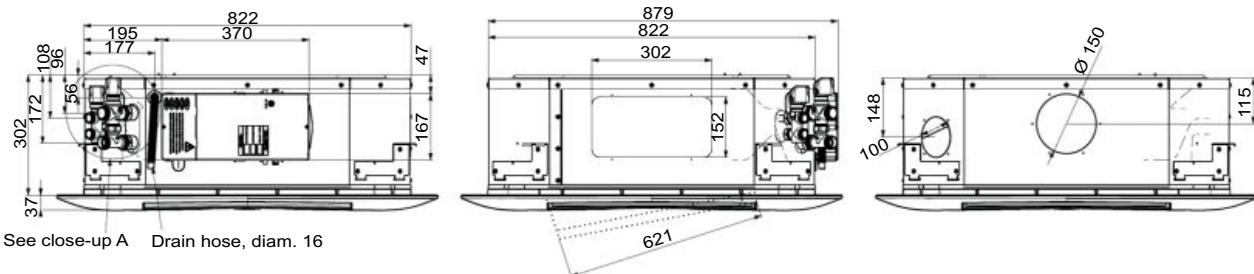

#### Close-up C

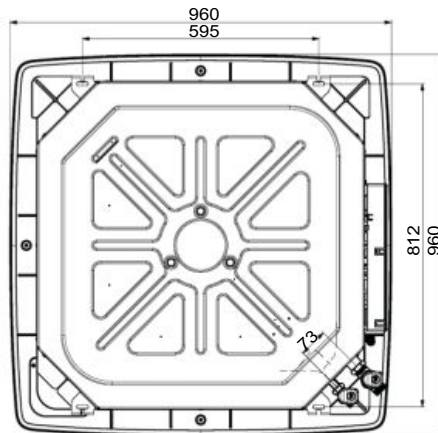
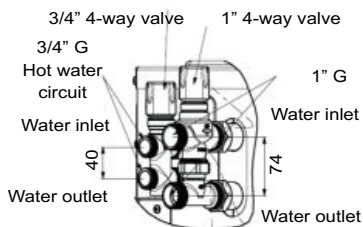

## COIL WATER CAPACITY

42GW		200/209	300/309	400/409	500/509	600/609	701/709
Coil volume	l	0,55	1,1	1,1	1,6	2,4	2,4

## AIR STREAM, IN METRES

42GW	All louvres open			One louvre closed			Two louvres closed		
	High speed	Medium speed	Low speed	High speed	Medium speed	Low speed	High speed	Medium speed	Low speed
200/209	3,8	3,2	2,7	4,3	3,7	3,0	4,8	4,1	3,4
300/309	4,0	3,4	2,8	4,5	3,8	3,2	5,0	4,3	3,5
400/409	4,8	4,1	3,4	5,3	4,5	3,7	5,8	4,9	4,1
500/509	3,0	2,6	2,1	3,5	3,0	2,5	4,0	3,4	2,8
600/609	3,4	2,9	2,4	3,9	3,3	2,7	4,4	3,7	3,1
701/709	4,3	3,7	3,0	4,8	4,1	3,4	5,3	4,5	3,7

### Notes:

- The louvres were set so as to use the Coanda effect to obtain an air flow model parallel to the ceiling, and adhering to it as much as possible.
- The air discharge is defined as the distance between the point where the air flow emerges from the unit parallel to the ceiling, and the point where its speed drops to 0.2 m/s.
- These values are supplied as a guide; they may vary according to the ceiling type, the room dimensions and even its furniture.

## OPERATING LIMITS

<b>Water circuit</b>	Maximum water side pressure: 1600 kPa (160 m WG)	Minimum entering water temperature: 5°C Maximum entering water temperature: 80°C
<b>Indoor temperature</b>		Minimum temperature: 5°C Maximum temperature: 32°C in heating mode with electric heating device
<b>Power supply</b>	Nominal voltage Operating limits	230 V - 1 ph - 50/60 Hz Min. 207 V - max. 253 V - units without electric heating device Min. 216 V - max. 244 V - units with electric heating device

## VALVE KIT

Valve kit	42GW 9029	42GW 9031	42GW 9030	42GW 9032	42GW 9033	42GW 9035	42GW 9034	42GW 9036
<b>Unit option (10<sup>th</sup> letter)</b>	H - 4-way	H - 4-way	H - 4-way	H - 4-way	G - 2-way	G - 2-way	G - 2-way	G - 2-way
<b>Description</b>	3/4" cooling	1" cooling	3/4" cooling + 1/2" heating	1" cooling + 3/4" heating	3/4" cooling	1" cooling	3/4" cooling + 1/2" heating	1" cooling + 3/4" heating
<b>Valve centre-to-centre, mm</b>	40	73	40/40	73/40	40	73	40/40	73/40
<b>Valve gasket coupling type</b>	Flat	Flat	Flat	Flat	Flat	Flat	Flat	Flat
<b>2-pipe</b>								
200C, 300C, 400C	x				x			
209C, 309C, 409C	x				x			
500C, 600C, 701C		x				x		
509C, 609C, 709C		x				x		
<b>4-pipe</b>								
200D, 300D, 400D			x				x	
209D, 309D, 409D			x				x	
600D, 701D				x				x
609D, 709D				x				x



## DUCTABLE FAN COIL UNIT



## 42NL & 42NH

The Carrier 42NH and 42NL are available in different sizes with 2-pipe, 2-pipe plus electric heater or 4-pipe coils, with an air flow range from 100 to 2300 m<sup>3</sup>/h, a total cooling capacity range from 0.6 kW to 12 kW and a nominal heating capacity range from 0.8 kW to 17 kW.



- Ductable unit for suspended ceiling
- Extremely quiet operation
- Low Energy Consumption
- Flexibility for simplified installation
- Improved comfort
- Indoor air quality



CARRIER participates in the ECP programme for FC-FCP  
Check ongoing validity of certificate:  
[www.eurovent-certification.com](http://www.eurovent-certification.com)

## 1 - FUNCTIONS AND CONFIGURATIONS

- Compact and modular ducted unit, designed for any false ceiling installation.
- Reliable and economical for tertiary building as hotel guest rooms, offices or light commercial applications.
- Low height of 235 mm (sizes 2/3/4/5) and 285 mm (sizes 6/7)
- Compatible with the Carrier diffuser ranges.
- Extremely low sound levels for ducted applications.
- Five- to Six- speed fan AC motors offers a wide choice of medium speeds.
- Available with Low Energy Consumption variable-speed EC motor.
- High-pressure centrifugal fan for 42NH Range
- G3 filter as standard.
- Safe factory installed electric heater with multiple capacity stages choices.
- Low water pressure drop with factory installed valves.
- Factory installed options (valves and controllers) for fast and easy installation in false ceilings.

### 1.1 - Modularity

Thanks to its two versions, the range is suitable for all applications.

The 42NL version is optimised for soffit installations while the 42NH is optimised for air return and supply ducted installations.

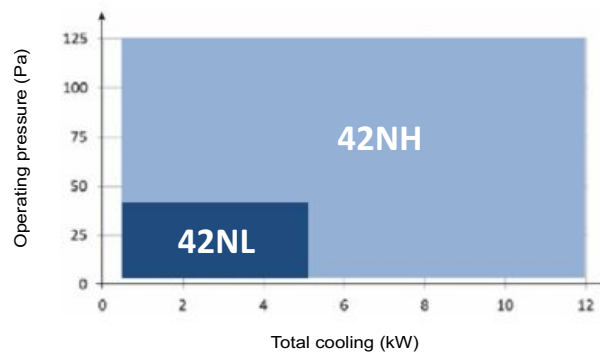

### 1.2 - Configuration and flexibility

Each of the 42NL and 42NH sizes can be equipped:

- With non-ducted return and/or direct supply;
- With a rectangular flange on the return and/or supply (ideal for connecting the fan coil unit to the air duct);
- With return and/or plenums including a large number of spigots with diameters of 160, 200 or 250 mm depending on the unit size.

The image below shows all available plenum configurations on the 42NL or 42NH (e.g. size 3) with a spigot diameter of 200 mm.

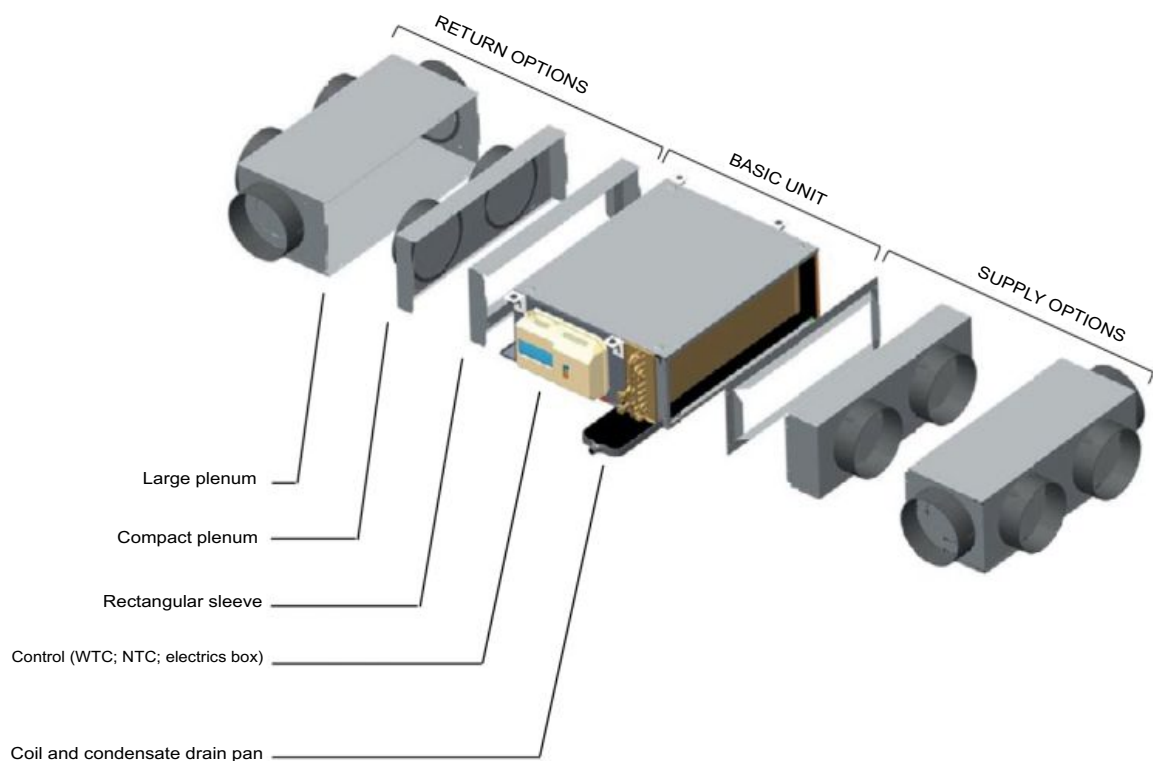



# 1 - FUNCTIONS AND CONFIGURATIONS

## 1.3 - Standard spigot configuration

Large and small plenums are available for all sizes as per the drawings below:

(\*) = Minimum number of spigots required to ensure sufficient available static pressure and fan reliability

	42NH & 42NL Size 2xx	42NH & 42NL Size 3xx	42NH & 42NL Size 4xx
LARGE RETURN OR SUPPLY	<p>4x DN 160 3x DN 200</p>	<p>4x DN 160 4x DN 200</p>	<p>5x DN 160 4x DN 200</p>
COMPACT RETURN OR SUPPLY	<p>2x DN 160 1x DN 200</p>	<p>2x DN 160 2x DN 200</p>	<p>3x DN 160 2x DN 200</p>
LIMITS (*)	MIN. NO. OF SPIGOTS = 1x160 or 1x200 (2x160 and 1x200 for 42NH279)	MIN. NO. OF SPIGOTS = 2x160 or 1x200 (2x160 and 2x200 for 42NL range)	MIN. NO. OF SPIGOTS = 3x160 or 2x200
	42NH & 42NL Size 5xx	42NH Size 6xx	42NH Size 7xx
LARGE RETURN OR SUPPLY	<p>6x DN 160 5x DN 200</p>	<p>5x DN 200 4x DN 250</p>	<p>6x DN 200 5x DN 250</p>
COMPACT RETURN OR SUPPLY	<p>4x DN 160 3x DN 200</p>	<p>3x DN 200 2x DN 250</p>	<p>4x DN 200 3x DN 250</p>
LIMITS (*)	MIN. NO. OF SPIGOTS = 3x160 or 2x200 (4x160 and 3x200 for 42NL range)	MIN. NO. OF SPIGOTS = 3x200 or 2x250	MIN. NO. OF SPIGOTS = 4x200 or 3x250

**NOTE:**

- Electrical heater are not available for 42NL Units when plenum are selected (due to minimum airflow requirement).
- Non-standard configurations not listed above can be provided upon special request. Contact your local Carrier representative.

# 1 - FUNCTIONS AND CONFIGURATIONS

Standard configuration with return and supply rectangular sleeves:

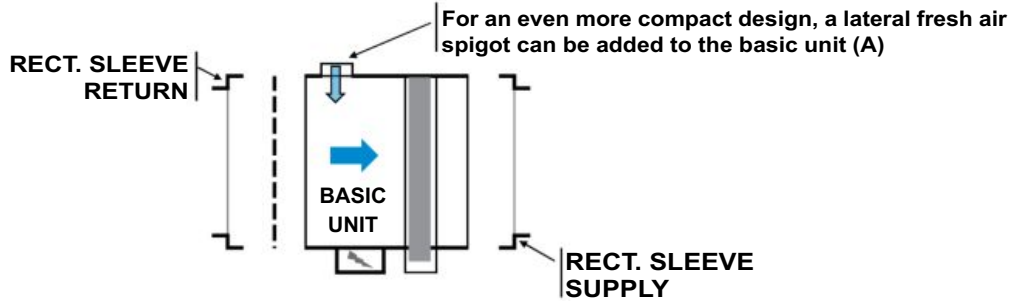

Standard configuration with spigots without fresh air:

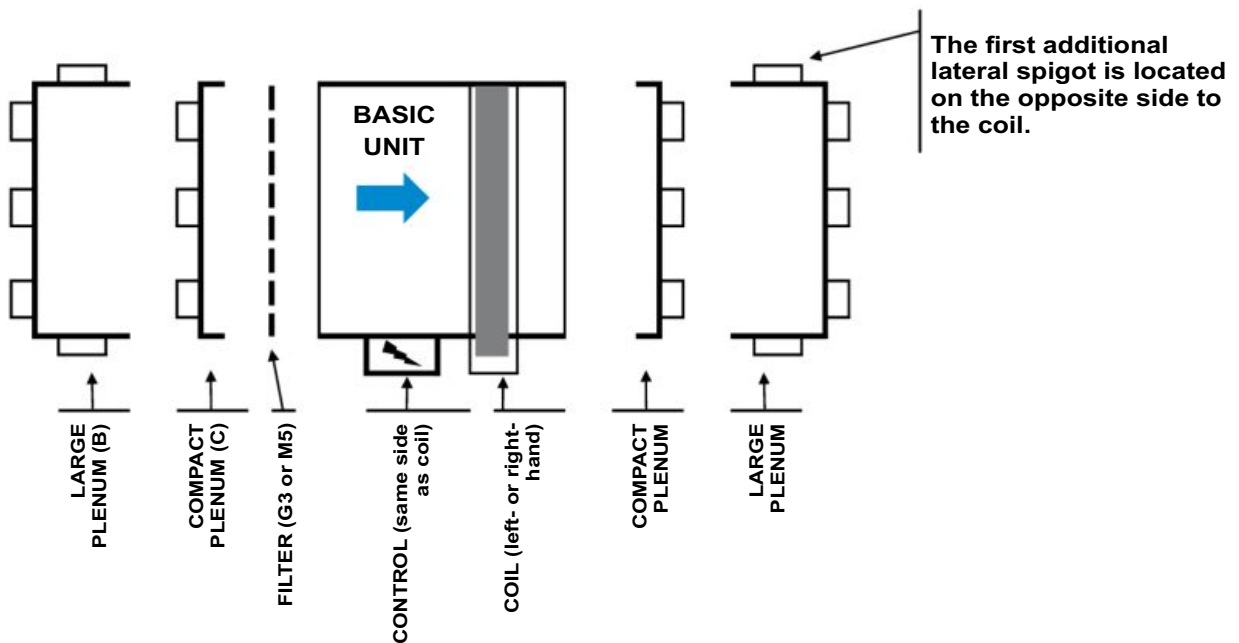

Standard configuration with fresh air return possibilities:

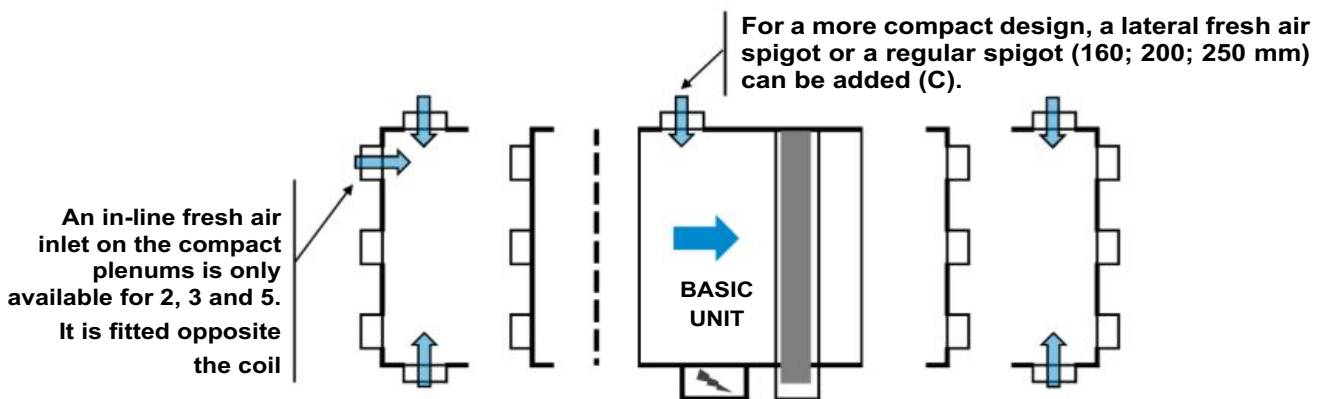

- Air flow direction
- Fresh air inlet

- (A) In this case, the air must be filtered beforehand to prevent any damage to the fan and the soiling of the coil.
- (B) Large plenum is required to fit the M5 filter
- (C) Without any filter the small inlet plenum is flat for improved compactness.

# 1 - FUNCTIONS AND CONFIGURATIONS

Additional configurations are displayed below:

**U-shaped**

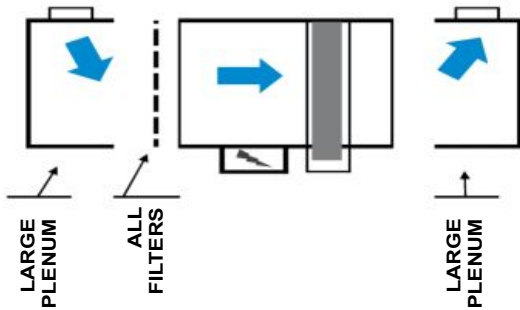

**L-shaped**

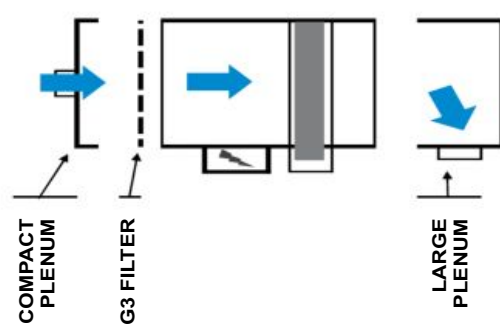

**T-shaped**

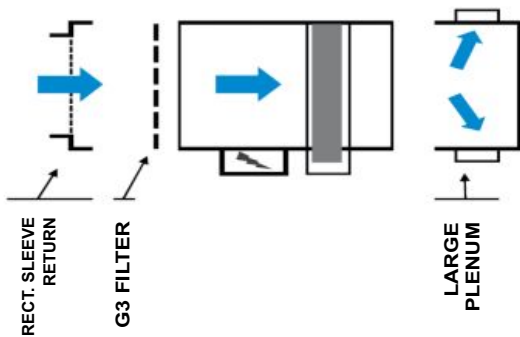

**H-shaped or I-shaped**

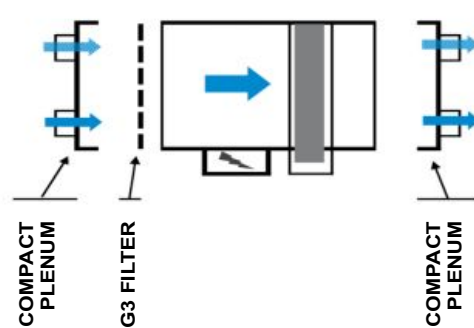

Configurations without filter (ultra-compact design)

**U-shaped**

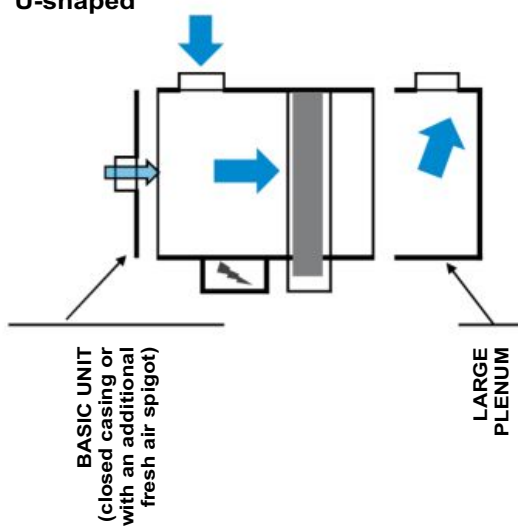

**H-shaped or I-shaped**

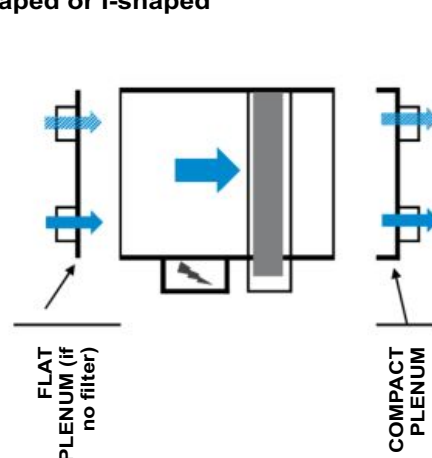

Compatibility Reminder	Size 2		Size 3	Sizes 4 to 7
	22x / 23x	279		
1x160	NH/NL	n.a.	n.a.	n.a.
1x200	NH/NL	NH	NH	n.a.
1x250	n.a.	n.a.	n.a.	n.a.

Compatibility Reminder	Size 2 to 3	Size 4	Size 5	Size 6	Size 7
2x160	NH/NL	n.a.	n.a.	n.a.	n.a.
2x200	NH/NL	NH/NL	NH	n.a.	n.a.
2x250	n.a.	n.a.	n.a.	NH	n.a.

NA: Not Available

# 1 - FUNCTIONS AND CONFIGURATIONS

## M5 filter configurations

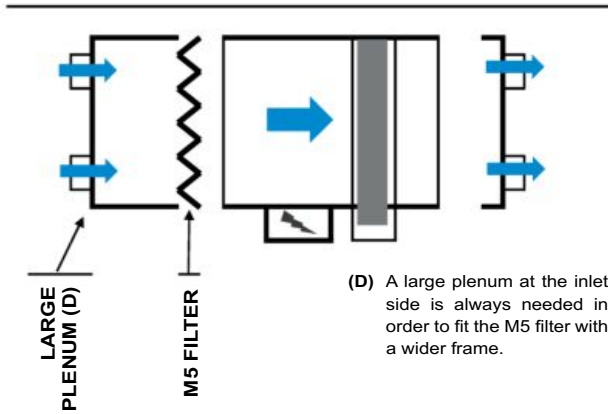

## Lateral fresh air configuration at the supply side

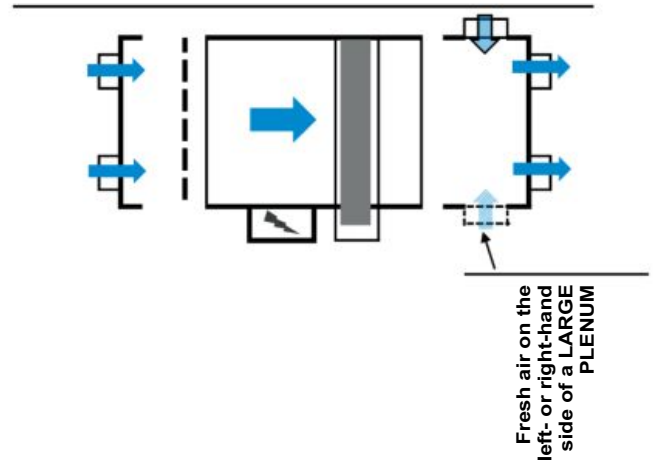

## Fresh air configurations at the return side

### Lateral fresh air (opposite side to coil) Option 1 "Optimised"

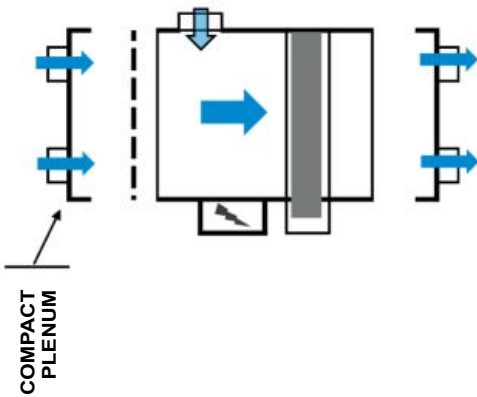

Inlet optimised: for a compact design, the fresh air is fitted on the basic unit (on the opposite side to the coil).

### Option 2 "In\_opp"

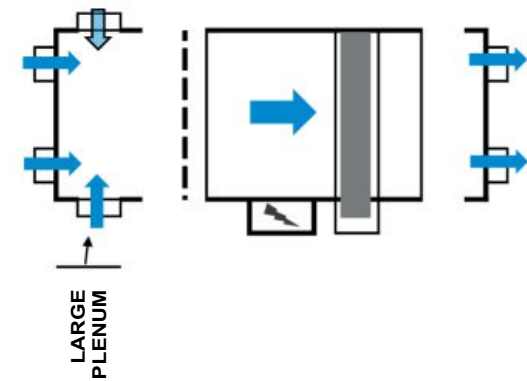

With this option, the fresh air is located opposite the coil and is always installed in a large plenum.

### Lateral fresh Air "In\_coil"

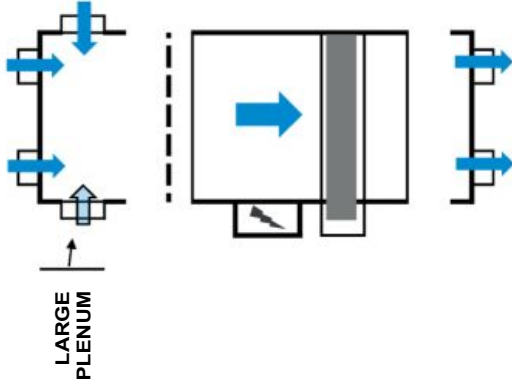

### "In\_line" fresh air (for sizes 2, 3 and 5)

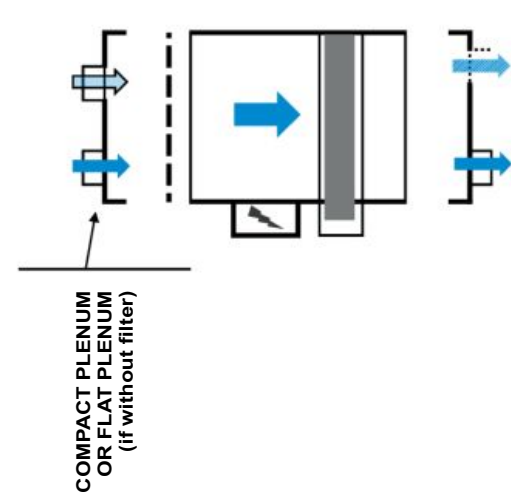

## 2 - DIMENSIONAL DRAWINGS

**NOTE:** All the drawings show the coil connection on the right-hand side. Coils with left-hand connections are strictly symmetrical,

### Standard unit without rectangular return and supply flanges

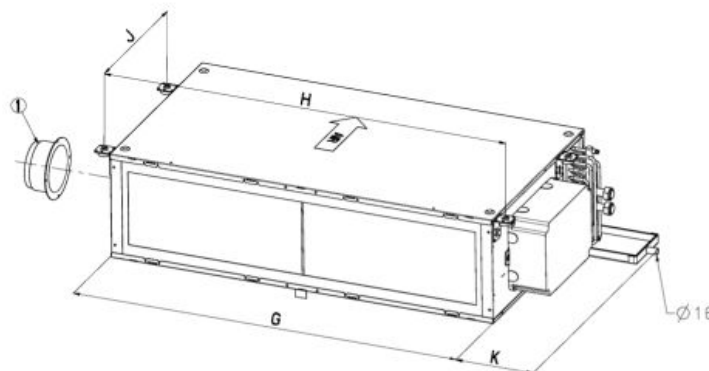
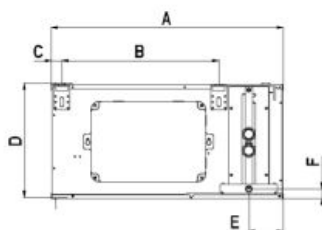

Dimensions in mm						
Size	2xx	3xx	4xx	5xx	6xx	7xx
A	520	520	520	520	575	575
B	330	330	330	330	385	385
C	25	25	25	25	25	25
D	235	235	235	235	285	285
E	85	85	85	85	85	85
F	17	17	17	17	25	25

Dimensions in mm						
Size	2xx	3xx	4xx	5xx	6xx	7xx
G	450	620	820	1020	1020	1320
H	500	670	870	1070	1070	1370
J	330	330	330	330	385	385
K	230	230	230	230	230	230
G + K	680	850	1050	1250	1250	1550
Weight* [kg]	15	18	23	27	30	36

### Standard unit with rectangular sleeves on the return and supply

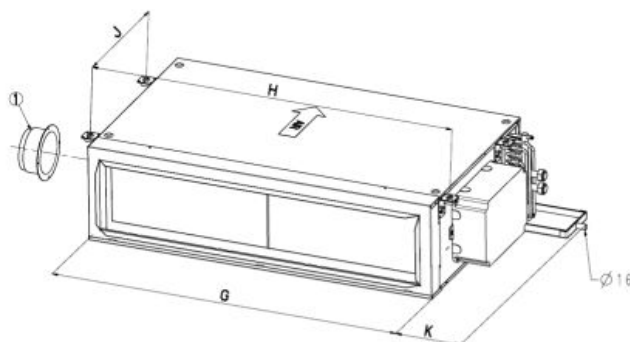
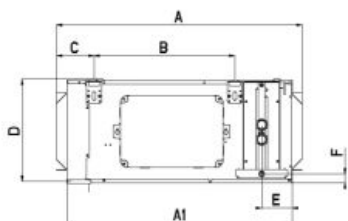

Dimensions in mm						
Size	2xx	3xx	4xx	5xx	6xx	7xx
A	615	615	615	615	670	670
B	330	330	330	330	385	385
C	103	103	103	103	103	103
D	235	235	235	235	285	285
E	85	85	85	85	85	85
Rectangular Flanges	380 x 160	550 x 160	750 x 160	950 x 160	950 x 210	1250 x 210

Dimensions in mm						
Size	2xx	3xx	4xx	5xx	6xx	7xx
F	17	17	17	17	25	25
A1	561	561	561	561	615	615
G	450	620	820	1020	1020	1320
H	500	670	870	1070	1070	1370
J	330	330	330	330	385	385
K	230	230	230	230	230	230
G + K	680	850	1050	1250	1250	1550
Weight* [kg]	15	18	23	27	30	36

#### KEY

- 1 Lateral optimized fresh air position in base unit (opposite to coil hand at inlet)
- \* Maximum weight 42NL/NH (AC or EC motor version) - without valve option - without water
- Air flow direction
- All dimensions are in mm.



## 2 - DIMENSIONAL DRAWINGS

### Unit without filter with compact plenum at return and supply (optimised length)

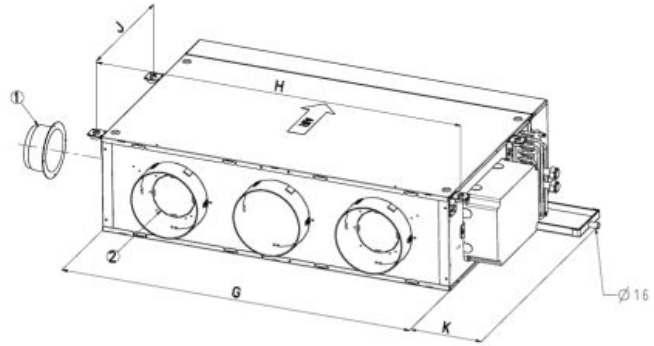
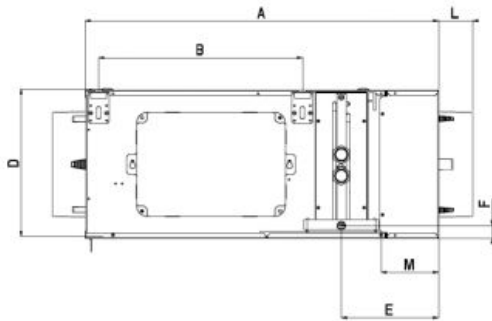

Dimensions in mm						
Size	2xx	3xx	4xx	5xx	6xx	7xx
A	611	611	611	611	666	666
B	330	330	330	330	385	385
C	25	25	25	25	25	25
D	235	235	235	235	285	285
E	185	185	185	185	185	185
F	17	17	17	17	25	25
G	450	620	820	1020	1020	1320

Dimensions in mm						
Size	2xx	3xx	4xx	5xx	6xx	7xx
H	500	670	870	1070	1070	1370
J	330	330	330	330	385	385
K	230	230	230	230	230	230
L	63	63	63	63	76	76
M	100	100	100	100	100	100
G + K	680	850	1050	1250	1250	1550
Weight* [kg]	19	23	29	33	37	44

### Unit with G3 filter and compact plenum at the return and supply

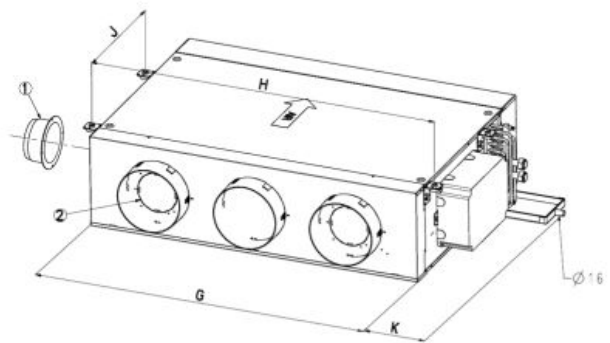
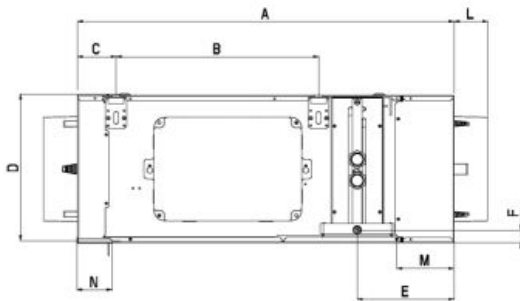

Dimensions in mm						
Size	2xx	3xx	4xx	5xx	6xx	7xx
A	660	660	660	660	715	715
B	330	330	330	330	385	385
C	75	75	75	75	75	75
D	235	235	235	235	285	285
E	185	185	185	185	185	185
F	17	17	17	17	25	25
G	450	620	820	1020	1020	1320

Dimensions in mm						
Size	2xx	3xx	4xx	5xx	6xx	7xx
H	500	670	870	1070	1070	1370
J	330	330	330	330	385	385
K	230	230	230	230	230	230
L	63	63	63	63	76	76
M	100	100	100	100	100	100
N	50	50	50	50	50	50
G + K	680	850	1050	1250	1250	1550
Weight* [kg]	19	23	29	33	37	44
G + K	680	850	1050	1250	1250	1550
Weight* [kg]	19	23	29	33	37	44

**KEY**

- 1 Lateral optimized fresh air position in base unit (opposite to coil hand at inlet)
- 2 In line fresh air position for compact plenum (with or without filter)
- \* Maximum weight 42NL/NH (AC or EC motor version) - without valve option - without water



Air flow direction  
All dimensions are in mm.

## 2 - DIMENSIONAL DRAWINGS

### Unit with G3 or M5 filter and large plenum at the return and supply

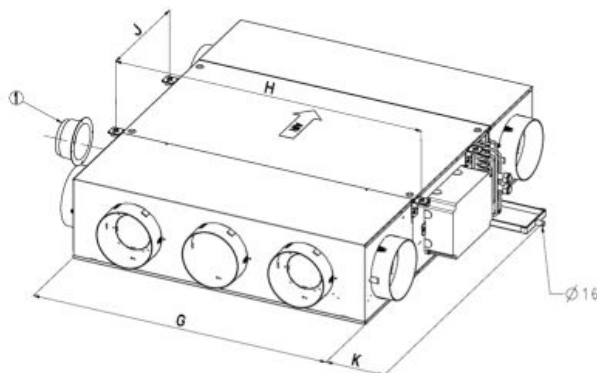
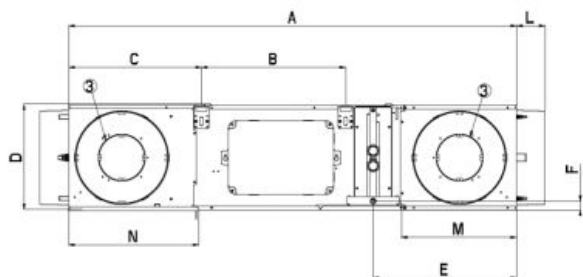

Dimensions in mm						
Size	2xx	3xx	4xx	5xx	6xx	7xx
A	1040	1040	1040	1040	1195	1195
B	330	330	330	330	385	385
C	305	305	305	305	355	355
D	235	235	235	235	285	285
E	333	333	333	333	382	382
F	17	17	17	17	25	25
G	450	620	820	1020	1020	1320

Dimensions in mm						
Size	2xx	3xx	4xx	5xx	6xx	7xx
H	500	670	870	1070	1070	1370
J	330	330	330	330	385	385
K	230	230	230	230	230	230
L	63	63	63	63	76	76
M	250	250	250	250	297	297
N	280	280	280	280	330	330
G + K	680	850	1050	1250	1250	1550
Weight* [kg]	22	27	34	40	45	53

#### KEY

- 1 Lateral optimized fresh air position in base unit (opposite to coil hand at inlet)
  - 3 Lateral fresh air position in large plenum (at inlet or outlet side)
  - \* Maximum weight 42NL/NH (AC or EC motor version) - without valve option - without water
- Air flow direction  
 All dimensions are in mm.

### Water coil

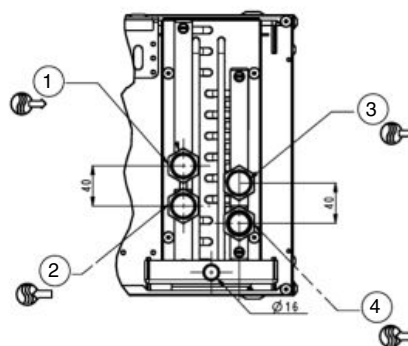
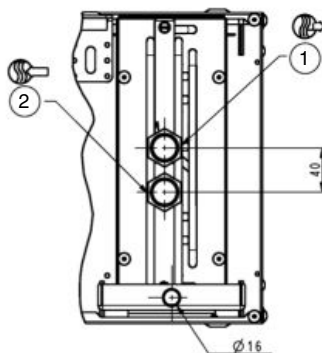

#### DN:

- 1/2" 42NH/NL 2xx, 3xx, 4xx, 5xx
- 3/4" 42NH 6xx, 7xx

- 1 Cooling water outlet for 4-pipe coil and heating/cooling for 2-pipe coil
- 2 Cooling water inlet for 4-pipe coil and heating/cooling for 2-pipe coil
- 3 Heating water outlet (4-pipe coil)
- 4 Heating water inlet (4-pipe coil)

## 3 - MAIN MODULES AND COMPONENTS

### 3.1 - Casing

In order to further enhance occupant comfort, this product range offers especially low noise levels. The casing is made of galvanised sheet steel with full high-efficiency internal lining for optimised thermal and sound insulation of the unit.

In order to comply with the various local regulations (fire class) the fan-coil unit is available with both class M1 type insulation (according to NF P 92-507) and Euroclass level B-s3-d0 (according to EN 13501). It is also equipped with anti-vibration mounts as standard.

In order to reduce the dimensions to the minimum, the units are equipped with high-efficiency heat exchangers with very high cooling capacity/treated air flow ratios. The condensate drain pan height is optimised.

### 3.2 - Fan motor assemblies

#### 3.2.1 - Multi-speed fan motor assembly compliant with ErP 2015 regulations

##### Motor description

- Asynchronous motors, 4 poles with internal overload protection
- Permanent capacitor
- Class B winding insulation, varnish class F
- See operating limits in chapter 8.

The 42NH and 42NL have a multi-speed fan motor assembly with forward curved, double inlet, single, double or triple wheel fans depending on the unit size.

Five speeds are available as standard for 42NH (Six speeds for 42NL). Three speeds must be selected to allow connection of the fan motor in accordance with applicable electromechanical or electronic control.

- Minimum speed: R5 for 42NH; R6 for 42NL
- Maximum speed: R1
- Units can be supplied with Carrier electronic controls and prewired to a selection of three speeds.
- For other fan motor Speed wiring combinations refer to the unit options list (chapter 6).

#### 3.2.2 - Low-consumption fan motor assembly (variable-speed LEC)

##### Motor description

- Permanent magnet brushless motor
- Electronically commutated
- Class B winding insulation, varnish class F
- See operating limits in chapter 8.

The 42NH and 42NL units are equipped with the LEC fan motor, which is controlled by a 0 to 10 V signal, available with the Carrier NTC or WTC type electronic control.

**NOTE: In this case the minimum control signal that allows the motor to start is 2 V for two- and four-pipe versions and 3 V for versions equipped with electric heaters.**

If the product is supplied without a Carrier control device, verification of EMC conformity is the responsibility of the installer.

### 3.3 - Fan wiring solutions

#### 3.3.1 - Multi-speed unit with bare wires (standard)

As standard, all speeds of the multi-speed fan are available with bare wires (six speeds for the 42NL and five speeds for the 42NH), offering greater flexibility.

Minimum speed = R6 or R5, maximum speed = R1.

#### 3.3.2 - Multi-speed unit with optional controller or electrics box

When ordering, three of the five speeds must be selected to enable the motor connection to comply with the applicable controller (NTC, WTC or electrics box for Carrier thermostats).

With the electrical box, the installer can connect the unit to a terminal board. The electrical box can be opened with a screw driver.

The electrical box permits changing the speed wiring without access to the motor. All available speeds are connected.

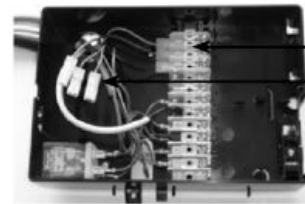

Wiring example: By default, R5 R3 R1 are connected on the terminal board.  
The other 2 or 3 speeds are available and easy to access

**NOTE: The standard wiring for all unit ranges is always R5 R3 R1.**

#### 3.3.3 - Variable-speed low energy consumption (LEC) fan motor with bare wires (standard)

The variable-speed low energy consumption (LEC) motor must be controlled by a 0-10 VDC signal.

#### 3.3.4 - Variable-speed low energy consumption (LEC) fan motor with electrics box

This option allows the installer to connect the unit to a terminal board inside an electrical box. The electrical box can be opened with a screw driver.

The 0-10 VDC signal that controls the variable-speed fan is directly accessible at the terminal strip.

#### 3.3.5 - Cover only option

A plastic cover accessory can be added to house a controller supplied by the customer (max. dimensions L = 200 mm x D = 100 mm x H = 95 mm). It is installed on site or in the factory on a multi-speed unit or on a variable speed fan motor with low energy consumption (LEC).

**NOTE: This option is not compatible with the electrics box option.**



## 3 - MAIN MODULES AND COMPONENTS

### 3.3.6 - Fuse holder option

A fuse holder can be provided as an option for all controllers or with the electrics box.



### 3.4 - Hydraulic coil

- Aluminium fins mechanically bonded by expansion onto copper tubes
- 1/2-inch threaded female water inlet and outlet connections for sizes 2 to 5
- 3/4-inch threaded female water inlet and outlet connections for sizes 6 and 7
- Air bleed valves and drain as standard.
- Operating pressure 1550 kPa.

The coil, condensate drain pan and coil access door are in the form of an easily removable drawer.

### 3.5 - Single unit condensate drain pan

Single unit condensate drain pan made from polypropylene and insulated with 5 mm of foam.

Drain connection diameter:  $\varnothing$  16 mm external  
HB fire rating (in compliance with UL94).

### 3.6 - Filter

#### 3.6.1 - Specifications

The 42NH and 42NL include as standard a G3 filter in compliance with EN 779.

A pleated M5 filter (for range 42NH only) according to EN 779 are also available. G3 and M5 filters have medium fire rating M1 (according to NFP 92-507) and a metal frame.

The "without filter" option is only available for units with a rectangular sleeve on the return side to ensure that a duct can be connected when the unit operates.

To prevent coil fouling, Carrier recommends the use of a filter installed in either the fan coil unit or in the return air grille.

The 42NH offers four filter configurations:

- Without filter: only available for units with an inlet plenum with spigots or with a rectangular flange inlet
- G3 filter: metal wire frame, medium efficiency supplied as standard
- M5 filter (only for 42NH): metal wire frame, high efficiency, thickness = 55 mm.

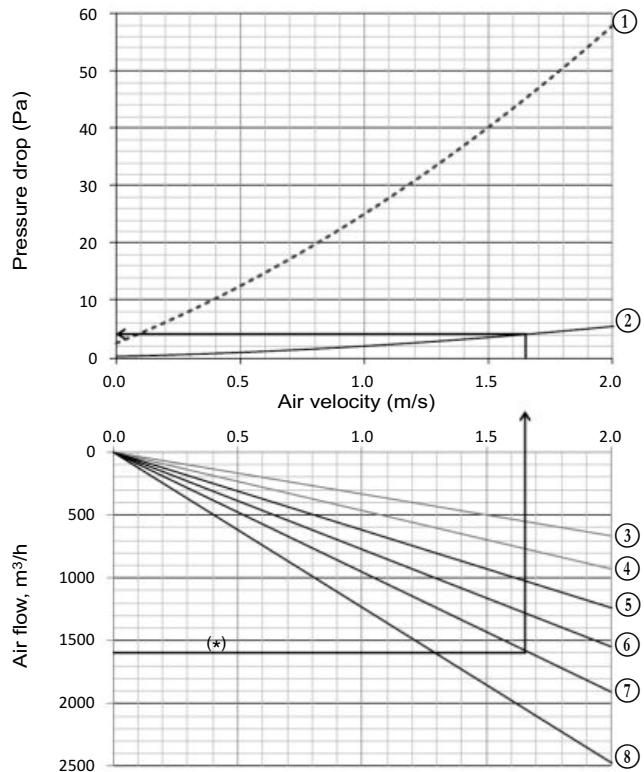

#### Key

- 1 M5 filter
- 2 G3 filter
- 3 Airflow for 42NH/NL Size 2
- 4 Airflow for 42NH/NL Size 3
- 5 Airflow for 42NH/NL Size 4
- 6 Airflow for 42NH/NL Size 5
- 7 Airflow for 42NH Size 6
- 8 Airflow for 42NH Size 7
- (\*) Example: The pressure drop of a G3 filter used in a 42NH645 is 5 Pa for a 1600 m<sup>3</sup>/h air flow.

### 3 - MAIN MODULES AND COMPONENTS

#### 3.6.2 - Filter access

Without a rectangular return sleeve, the filter is removed from the rear.

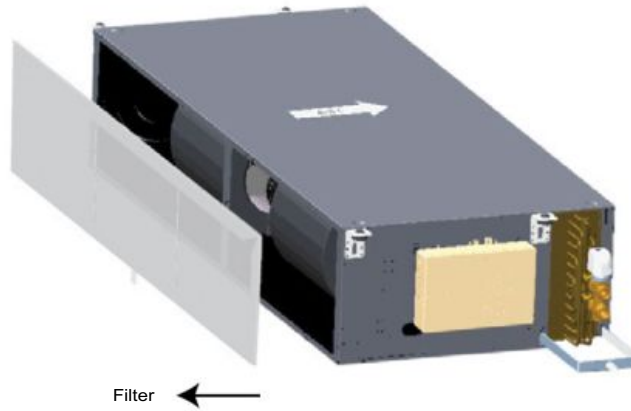

With a rectangular sleeve or return plenum, the filter is removed from below (hatch).

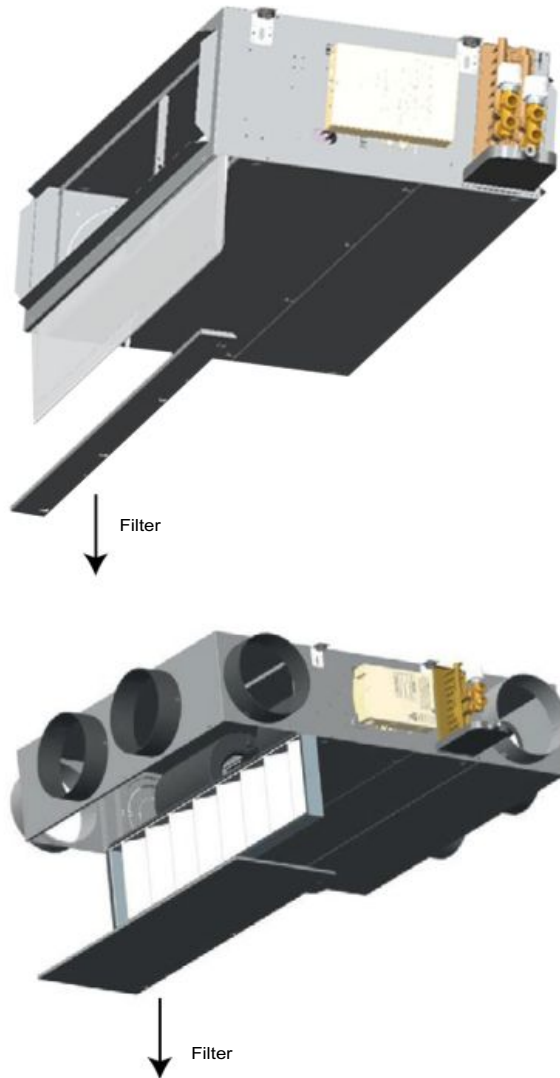



## 4 - OPTIONS SPECIFICATIONS

### 4.1 - Electric heater (option for 2-pipe coil)

Resistive wire type heater

- Supply voltage: 230 V - 1 ph - 50 Hz
- Heater size and capacity per unit (+5% ; -10%):

Electrical Heater Capacity	Low	Medium	High	Very High
42NH/NL 2-5	1 x 500 W	1 x 800 W	1 x 1000 W	NA
42NH/NL 2-9	1 x 500 W	1 x 800 W	1 x 1000 W	NA
42NH/NL 3-5	1 x 500 W	1 x 800 W	1 x 1000 W	1 x 1600 W
42NH/NL 3-9	1 x 500 W	1 x 800 W	1 x 1000 W	1 x 1600 W
42NH/NL 4-5	2 x 500 W	2 x 800 W	2 x 1000 W	NA
42NH/NL 4-9	1 x 500 W	1 x 800 W	1 x 1000 W	1 x 1600 W
42NH/NL 5-5	2 x 500 W	2 x 800 W	2 x 1000 W	NA
42NH/NL 5-9	2 x 500 W	2 x 800 W	2 x 1000 W	NA
42NH 6-5	2 x 500 W	2 x 800 W	2 x 1000 W	2 x 1600 W
42NH 6-9	2 x 500 W	2 x 800 W	2 x 1000 W	2 x 1600 W
42NH 7-5	2 x 500 W	2 x 800 W	2 x 1000 W	2 x 1600 W
42NH 7-9	2 x 500 W	3 x 500 W	3 x 800 W	3 x 1000 W

- The heater is protected with a dual safety device:
  - a) Self-holding automatically reset integrated safety thermostat
  - b) Destructive thermofuse link
- Available for 2-pipe coil only.

**WARNING: Minimum supply air flow must be maintained to avoid damaging the electric heaters.**

A minimum control signal of 3 V is selected by default with Electronic Carrier controller (NTC / WTC). To prevent low air flow with the 42NL range, plenums are not available as an option.

### 4.2 - Fresh air controller (option)

#### 4.2.1 - Constant volume fresh air controller

The coil can be fitted with a constant fresh air flow controller adjustable from 15 m<sup>3</sup>/h to 180 m<sup>3</sup>/h to allow the fresh air intake and the air change rate to be controlled.

The fresh air supply can be located in the air supply plenum, in the air return plenum or in the side of the basic unit casing for a compact design.

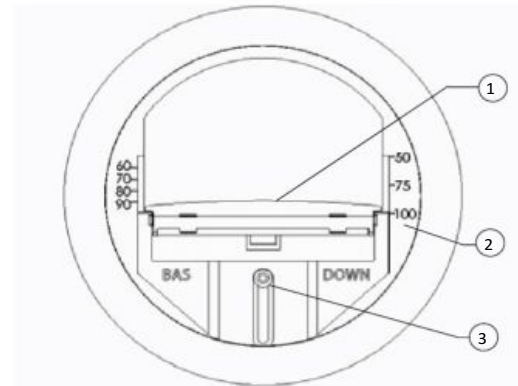

**Example: Range 50-100 m<sup>3</sup>/h**

- 1 Air Damper
- 2 Fresh airflow damper position setting (in m<sup>3</sup>/h)
- 3 Airflow adjustment screw

The fresh air controller may be modified on site by relocating the damper (adjustable screw). Three ranges of air-controller are provided: 15 to 50m<sup>3</sup>/h, 60 to 100m<sup>3</sup>/h and 110 to 180m<sup>3</sup>/h.

**IMPORTANT: If an optional return air temperature sensor is provided, the constant fresh air flow rate must not exceed 50 % of the unit supply air flow rate at minimum speed.**

**NOTE: To operate correctly, the fresh air flow controller requires a differential pressure in the range of 60 Pa to 210 Pa.**

#### 4.2.2 - Variable volume fresh air controller

The unit can be equipped with an optional variable fresh air flow controller from 0-55 l/s (0-200 m<sup>3</sup>/h). It is connected to the numeric Carrier controller and can regulate the fresh air intake in two ways:

- Either using a fixed rate set by the installer that can be reconfigured as required
- Or based on the CO<sub>2</sub> level; in this case it is connected to a CO<sub>2</sub> sensor via the Carrier numeric controller.



**NOTE: With the variable fresh air flow controller the pressure upstream of the fresh air duct must be 180 Pa.**

## 4 - OPTIONS SPECIFICATIONS

### 4.3 - Valves and actuators (option)

**NOTE:** The motor/valve assembly is normally closed.

#### 4.3.1 - Valve actuators

A wide choice of actuators is available with two- or four-way valve bodies (three-way with integral bypass) to offer the right solution for any controller type and customer requirement, from on/off to proportional types, with either 230 V or 24 V power supply:

- On/off 230 V actuator
- On/off 24 V actuator
- Floating 3-point 230 V actuator
- Floating 3-point 24 V actuator
- Modulating 0-10 V/24 V actuator

When combined with LEC motors and WTC or NTC controllers, floating 3-point 230 V actuators are recommended to increase energy savings and enhance comfort.

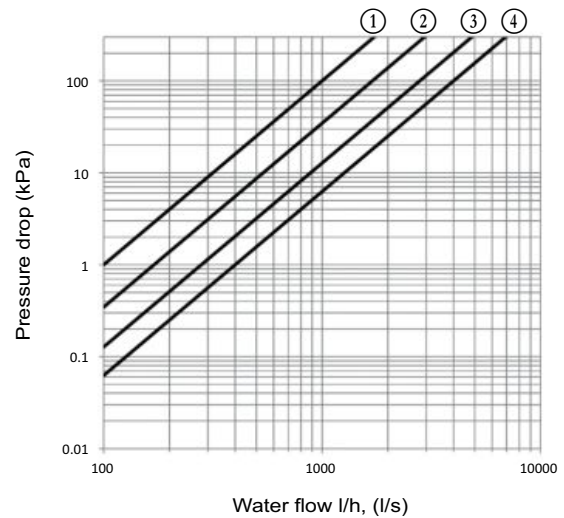

#### Key

- 1 1/2" - ON/OFF valve 42NL/NH - Size 2 Kvs = 1
- 2 1/2" - ON/OFF valve 42NL/NH - Sizes 3, 4, 5 Kvs = 1.7
- 3 3/4" - ON/OFF valve 42NL/NH - Size 6 Kvs = 2.8
- 4 3/4" - ON/OFF valve 42NL/NH - Size 7 Kvs = 4

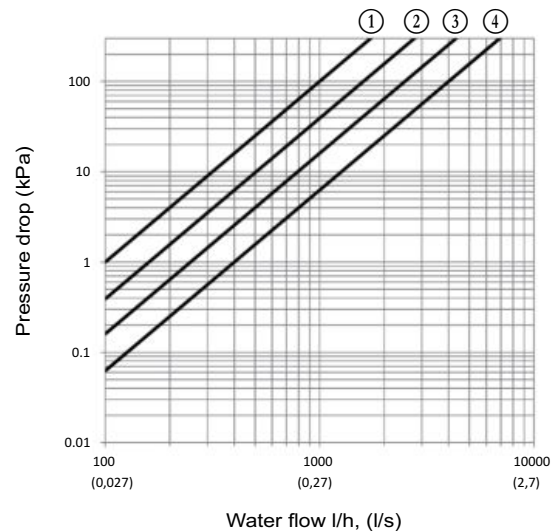

#### Key

- 1 1/2" - Modulating valve (3-points & 0-10V) 42NL/NH - Size 2 Kvs = 1
- 2 1/2" - Modulating valve (3-points & 0-10V) 42NL/NH - Sizes 3, 4, 5 Kvs = 1.6
- 3 3/4" - Modulating valve (3-points & 0-10V) 42NL/NH - Size 6 Kvs = 2.5
- 4 3/4" - Modulating valve (3-points & 0-10V) 42NL/NH - Size 7 Kvs = 4

**NOTE:** 24 V power supply actuators are not compatible with Carrier controllers (Thermostats A/B/C/D, WTC and NTC).

#### 4.3.2 - Standard two-way valve body and three-way valve body (with integral bypass)

##### Features of the 1/2" two-way and three-way valves for 42NL/NH sizes 2 to 5

- 1/2" male BSP connection for union nuts
- Straight valve body with arrow indicating direction of flow embossed on valve body
- Nominal size DN15 for 1/2" valve
- Nominal pressure: PN 16 bar

##### Features of the 3/4" two-way and three-way valves for 42NH sizes 6 and 7

- 3/4" male BSP connection for union nuts
- Straight valve body with arrow indicating direction of flow embossed on valve body
- Nominal size DN20 for 3/4" valve
- Nominal pressure: PN 16 bar

## 4 - OPTIONS SPECIFICATIONS

### 4.3.3 - Two way balancing valve body

New two-way valves with embedded balancing function technology are available as an option with 42NH and 42NL units. The Carrier two-way valve with balancing function combines the functionality of a dynamic balancing valve and a control valve in one product.



The dynamic balancing function maintains a constant differential pressure over the control valve.

The control valve regulates the flow by means of a variable orifice which is controlled by the actuator.

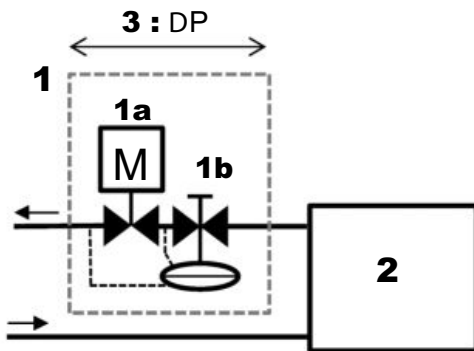

**Key**

- 1. Two-way valve with balancing function
  - 1a. Valve actuator for waterflow control
  - 1b. Differential pressure controller & balancing feature
- 2. Fan-coil unit
- 3. Minimum operating pressure drop at nominal waterflow: 20 kPa for sizes 4 and 5

The constant differential pressure across the control valve ensures accurate control and maximises valve authority, independently of the pressure conditions in the system.

### Advantages compared to the standard two-way valve

- Improved and reliable commissioning. The water flow can be set and controlled on site.
- Higher energy efficiency due to optimal waterflow and maximized valve authority.
- Enhanced comfort thanks to stable and precise ambient temperature control.

### Features of the 1" two-way valves with balancing function for 42NL/NH sizes

- 1" male BSP connection for union nuts
- Straight valve body with arrow indicating direction of flow embossed on valve body
- Nominal size DN 20 for 1" valve
- Nominal pressure: PN 16 bar
- Minimum operating differential pressure = 20 kPa at nominal flow.

As a secondary option, two pressure points can be added to the valve body in order to accurately measure the flow rate during the commissioning and maintenance stages.

Sizes	2xx & 3xx	4xx & 5xx
<b>water flow range</b>	100-575 l/h	220 - 1330 l/h
<b>Nominal Diameter</b>	DN15	DN20
<b>Thread</b>	G3/4" for flat washer	G 1" for flat washer

### 4.4 - Flexible water pipes (option)

#### 4.4.1 - Materials

- Pipes: EPDM-based elastomer (Ethylene Propylene Diene Monomer)
- Braid: 304L stainless steel
- Insulation: cellular foam rubber with M1 fire rating (9 mm thick, flexible water pipes).

#### 4.4.2 - Characteristics

- Minimum bend radius (insulated pipes): 106 mm
- The flexible water pipes are designed for treated or untreated water.
- Maximum operating pressure: 16 bar
- 1/2" female flat gas connections for sizes 2, 3, 4 and 5
- 3/4" female flat gas connections for sizes 6 and 7
- Length: 1 m.

## 4 - OPTIONS SPECIFICATIONS

### 4.5 - Sensors (option)

#### 4.5.1 - Water temperature sensor

A water temperature sensor can be provided as an option for NTC and WTC controllers.

- For 2-pipe coil: The sensor is installed on a cooling/heating water pipe (for change-over function).
- For 4-pipe coil: The sensor is installed on a heating water pipe (for cold-draft function that prevents the operation of the unit when the heating network is off).

The fan coil unit is delivered with an electricals box, the "water temperature sensor" option is actually a switch that will be connected to the Carrier thermostat.

#### NOTE:

- *The water sensor option (switch) with electrical box is only available for 2-pipe coil without electrical heater.*
- *A water probe can also be provided as an accessory only in order to use the cold draft function of the thermostat.*

#### 4.5.2 - Air temperature sensors

Two factory-fitted air temperature sensors are available as an option for NTC and WTC controllers. They measure the temperature at the supply and/or return side.

#### 4.5.3 - CO<sub>2</sub> sensor

For indoor air quality control, a CO<sub>2</sub> sensor is available as an option for NTC and WTC controllers. The sensor is factory fitted at the inlet side.

### 4.6 - Condensate pump (option)

The condensate pump option is designed to fit on the side of the unit drain pan. Electrical power supply 230V-50/60Hz.

Condensate pump discharge performances:

Sizes 2 to 5 : Water flow rate in litres per hour (-15% / +20%)				
Discharge head	Horizontal length of the discharge pipe			
	5 metres	10 metres	20 metres	30 metres
1 metre	10,4	9,1	8,3	7,3
2 metres	8,5	7,8	7	6,4
3 metres	7,9	7,1	6,3	5,8
4 metres	7	6	5,3	4,9

Size 6 & 7 : Water flow rate in litres per hour (-15% / +20%)				
Discharge head	Horizontal length of the discharge pipe			
	5 metres	10 metres	20 metres	30 metres
1 metre	17	17	16	14
2 metres	14	14	13,5	11,2
3 metres	13	13	12	9,5
4 metres	11,5	10,5	10	8,3



Technical characteristics	Size 2-5	Size 6 & 7
Max. flow rate	10,4 l/h	17 l/h
Max. discharge height	7 m (flow rate 4 l/h)	> 8 m (flow rate 4 l/h)
Maximum pressure	10 m (flow rate 0 l/h)	14 m (flow rate 0 l/h)
Sound level at 1 m as per EN ISO 3744 and 4871 (Measurement taken at LNE, pump in water, outside of application)	20,2 dBA	<28 dBA
Power supply	230V +10%/-15% - 50/60Hz – 19W	230V +10%/-15% - 50/60Hz – 19W
Electrical insulation class	Class 1	Class 1
Detection levels	ON: 14,7 mm, OFF: 10,7 mm, AL: 17 mm	ON: 14,7 mm, OFF: 10,7 mm, AL: 17 mm
Safety switch	BS: 5A resistive – 250V Contacts made from AgNI 90/10, gold-plated	BS: 5A resistive – 250V Contacts made from AgNI 90/10, gold-plated
Heat protection (overheating)	70°C (automatic restart)	70°C (automatic restart)
Operating cycle (duty factor)	100%	100%
Protection (as per BS EN 60529)	IP64	IP64
Safety standard	CE	CE
RoHS directive	Compliant	Compliant
WEEE directive	Compliant	Compliant

## 5 - CONTROL (OPTION)

The unit can be supplied with a wide range of Carrier controls. These offer functions to suit the various application requirements, summarised in the table below.

	Thermostats	NTC	WTC
<b>Communication protocols</b>			
Carrier Communication Network (CCN) Aquasmart compatible		x	
BACnet MSTP			x
LON			x
<b>Control algorithms</b>			
On-off	x		
Proportional-integral		x	x
Carrier Energy saving algorithm		x	x
<b>Fan control</b>			
3 fixed speeds for AC motors	Types A and B	x	x
Automatic optimum fan speed selection	x	x	x
3 fixed speeds for EC motors	Types C and D	x	x
EC motors Variable speed		x	x
<b>Water valve management</b>			
Air flow control only (no water valve)	x		
230V On-off actuators	x	x	x
230V Modulating actuators (floating 3pts)		x	x
<b>Main functions</b>			
Setpoint control	x	x	x
Occupied/unoccupied mode	x	x	x
Frost protection mode	x	x	x
Window/door contact input	x	x	x
Measurement of water inlet temperature for automatic seasonal changeover (2 pipes)	Type A&C	x	x
Measurement of water inlet temperature to prevent cold-draughts (4 pipes and 2 pipes + electric heater)	Types B and D	x	x
Manual changeover	x	x	x
Frost protection mode	x	x	x
Continuous ventilation within dead-band	x	x	x
Periodical ventilation within dead-band	x	x	x
On-site configuration	x	x	x
Unit grouping Master/Slave	x	x	x
Cassette Louvers control		x	x
Supply air temperature monitoring limiting		x	x
Electrical heater loadshed		x	x
Dirty filter alarm		x	x
Alarm reporting		x	x
Indoor Air Quality control (CO <sub>2</sub> sensor)		o	o
Demand-controlled ventilation (DCV) (0-10 V fresh air valve)		o	o
Free cooling mode			o
Presence detection			o
<b>User interfaces</b>			
Automatic or manual fan speed control	x	x	x
Setpoint adjustment	x	x	x
Occupancy (eco) button	x	x	o
Digital display		o	o
CO <sub>2</sub> sensor		o	o
<b>Control kit</b>			
On site control kit solution			o

**Key**

X Feature available as standard

O Optional

**NOTE:** For the features and specifications of the Carrier controllers, refer to the technical documentation for each controller.

Upon special request, other controller types can be factory-installed on the units (supplied by Carrier or the customer).



## 6 - PRODUCT CHARACTERISTICS LIST

Characteristic Name		Digit n° Codification	Value	Description	Pack.	Compatibility
Range		1-2	42			
		3-4	NH			
			NL			
UNIT SIZE (Digits 5 - 6 - 7)	Chassis size	5	2	Chassis Size 2	Yes	Unit size availability (Digit n° 5-6-7): 2-pipe: NL / NH 225;235;229;239;279 4-pipe: NL / NH 235;239;279
			3	Chassis size 3		
			4	Chassis Size 4		
			5	Chassis Size 5		
			6	Chassis Size 6		
	Efficiency	6	2	Standard efficiency	Yes	NL / NH 325;335;329;339 NL / NH 425;435;429;439 NL / NH 525;535;529;539 NL / NH 635;645;639;649
			3	Medium efficiency		
			4	High efficiency		
			7	Extra High efficiency		
	Fan type	7	5	AC multispeed motor	Yes	NH 735;745;739;749 NH 735;745;739;749
			9	EC low consumption motor		
	Coil hand & type	8	F	2 pipes coil Left Hand	Yes	
G			2 pipes coil Right Hand			
C			4 pipes coil Left Hand			
D			4 pipes coil Right Hand			
Control	9	-	Bare wires	Yes	Valves and actuators must be selected with NTC	
		E	Electrics box			
		K	NTC			
		L	WTC LON			
		M	WTC BACNET			
Valve body	10	-	Without valve	Yes	Balancing valves are not available for unit sizes 6xx and 7xx	
		G	2-way valve	Yes		
		H	4-way valve	Yes		
		L	2-way balancing valve	No		
		T	2-way balancing valve and pressure points	No		
Electrical heater	11	-	Without electric heater	Yes	Electrical heaters are not compatible with 42NL with plenum. Highest capacity for unit size 2xx Highest capacity for unit sizes 3xx and 4x9 Highest capacity for unit sizes 4x5 and 5xx Highest capacity for unit sizes 7x9 Highest capacity for unit sizes 6xx and 7x5	
		E	500W electric heater			
		F	800W electric heater			
		G	1000W electric heater			
		H	1500W electric heater			
		J	1600W electric heater			
		K	2000W electric heater			
		L	2400W electric heater			
		M	3000W electric heater			
N	3200W electric heater					
Valve actuator	12	-	Without actuator	Yes	24 V actuators are not available with Carrier controllers. 3-point floating actuators are not available with the electrics box	
		A	230V ON/OFF actuator	Yes		
		C	230V floating actuator (3 points)	No		
		B	24V ON/OFF actuator	Yes		
		D	24V floating actuator (3 points)	No		
		E	24V 0-10V modulating actuator	No		
Rectangular flanges	13	-	Without rectangular flange	Yes		
		A	Outlet rectangular flange only	Yes		
		B	Inlet rectangular flange only	Yes		
		C	Inlet and outlet rectangular flanges	Yes		
Specific (options selection)	14	-	Without specific option	Yes		
		A	With specific options (factory fitted)	Yes		

## Key:

Default value for mandatory characteristic

Pack: Available with individual packaging

## 6 - PRODUCT CHARACTERISTICS LIST

Specific options (can be selected if digit no. 14 = A\*)

Characteristic Name	Value	Description	Pack.	Compatibility
Indoor air quality	Without		Yes	Only available with rect. flanges or plenum
	G3	Filter	Yes	
	M5		No	M5 filter only available for 42NH units with plenum
Fan speed wiring for AC motor	654			
	653	AC motor speeds arrangement:		
	652			
	651	R6 = minimum speed for 42NL		
	643	R5 = minimum speed for 42NH		
	642			
	641	R1 = maximum speed		
	632			
	631			
	621		Yes	R6 not available for 42NH range
	543			
	542			
	541			
	532	When this option is not selected, the standard wiring for all 42NL and 42NH units is always R5-R3-R1		
	531			
	521			
432				
431				
421				
321				
Packaging	Bundle	Filmed on a pallet (shrink wrap)	-	
	Individual	Individual packaging		
Inlet plenum	1_inline	1 spigot in line	No	According to unit sizes, filter and fresh air position Use selection software for more informations
	1_lat_op	1 lateral spigot opposite to coil side		
	1_lat	1 lateral spigot at coil side		
	2	2 spigots		
	2_lat	2 lateral spigots		
	3	3 spigots		
	4	4 spigots		
	5	5 spigots		
6	6 spigots			
Outlet plenum	7	7 spigots	No	According to unit sizes, filter and fresh air position Use selection software for more informations
	1_inline	1 spigot in line		
	1_lat_op	1 lateral spigot opposite to coil side		
	1_lat	1 lateral spigot at coil side		
	2	2 spigots		
	2_lat	2 lateral spigots		
	3	3 spigots		
	4	4 spigots		
5	5 spigots			
6	6 spigots			

**Key:**  
 Default value for mandatory characteristic  
 Pack: Available with individual packaging

\* If digit no. 14 = "-" the default values are selected.  
 Boolean: yes or no

## 6 - PRODUCT CHARACTERISTICS LIST

Characteristic Name	Value	Description	Pack.	Compatibility
Inlet spigots diameter	DN160	Spigot diameter	No	DN160 Not available for unit sizes 6xx to 7xx DN250 Not available for unit sizes 2xx to 5xx
	DN200			
	DN250			
Outlet spigots diameter	DN160	Spigot diameter	No	DN160 Not available for unit sizes 6xx to 7xx DN250 Not available for unit sizes 2xx to 5xx
	DN200			
	DN250			
Fresh air	DN125	Without controller - spigot only	No	Motorized air damper compatible with NTC and WTC only (Position feedback is not available if WTC and CO <sub>2</sub> sensor are also selected)
	DN125_15_50	15 to 50 m <sup>3</sup> /h controller		
	DN125_50_100	50 to 100 m <sup>3</sup> /h controller		
	DN125_100_180	100 to 180 m <sup>3</sup> /h controller		
	Adaptor_D125	For motorized air damper (to be ordered separately)		
Fresh air position	In_opp	At inlet side opposite to coil hand	No	According to unit sizes, filter and spigots selection Use selection software for more informations
	In_coil	At inlet side same as coil hand		
	In_line	At inlet rear side		
	Optimized	Inlet optimized: opposite to coil hand in base unit for compact design		
	Out_opp	At outlet side opposite to coil hand		
	Out_coil	At outlet side same as coil hand		
Fuse holder	boolean	Fuse holder	Yes	
Plastic cover	boolean	Plastic cover	Yes	For bare wires (without control only)
Condensate pump	boolean	Condensate pump	No	
Flexible	boolean	Flexible hoses	No	
Return air sensor	boolean	Return air temperature sensor	Yes	Compatible with NTC and WTC only
Supply air sensor	boolean	Supply air temperature sensor	Yes	Compatible with NTC and WTC only
Water temperature sensor	boolean	Water temperature sensor	Yes	According to controller and coil type
CO <sub>2</sub> sensor	boolean	CO <sub>2</sub> sensor	Yes	Compatible with NTC and WTC only

**Key:**

Pack: Available with individual packaging

\* If digit no. 14 = "-" the default values are selected.

Boolean: yes or no

## 7 - 42NH AND 42NL PERFORMANCE DATA

### 7.1 - Physical and electrical data at Eurovent conditions - 42NL - Sizes 2 and 3

With G3 filter - without plenum

42NL	225						235						
	R6	R5	R4	R3	R2	R1	R6	R5	R4	R3	R2	R1	
<b>Fan speed</b>													
(Eurovent certification speeds)	(L)	(M)	(H)			(Max)	(L)	(M)	(H)			Max	
Air flow	l/s	59	69	96	109	125	138	59	69	96	109	125	138
	m <sup>3</sup> /h	214	248	346	393	449	496	214	248	346	393	449	496
Available static pressure	Pa	0	0	0	0	0	0	0	0	0	0	0	0
<b>Cooling mode, two pipes<sup>(1)</sup></b>													
Total cooling capacity	kW	1,17	1,33	1,72	1,87	2,03	2,13	1,35	1,54	2,04	2,25	2,46	2,62
Sensible cooling capacity	kW	0,93	1,06	1,40	1,54	1,69	1,80	1,03	1,18	1,59	1,76	1,96	2,10
Water flow	l/s	0,06	0,06	0,08	0,09	0,10	0,11	0,07	0,08	0,10	0,11	0,12	0,13
	l/h	210	230	300	330	360	380	240	270	360	400	430	460
Water pressure drop	kPa	16,2	20,4	31,4	36,5	42	46,3	12,2	15,6	26,5	31	36,3	40,7
Water volume	l	0,4						0,5					
<b>Heating mode, two pipes<sup>(2)</sup></b>													
Heating capacity	kW	1,39	1,58	2,07	2,28	2,50	2,68	1,57	1,80	2,41	2,69	2,99	3,23
Water flow	l/s	0,07	0,08	0,10	0,11	0,12	0,13	0,08	0,09	0,12	0,13	0,14	0,16
	l/h	240	270	360	400	440	470	270	310	420	470	520	560
Water pressure drop	kPa	17,9	22,1	35	41,3	48,6	54,7	13,9	17,3	28,4	34,2	41	46,8
Water volume	l	0,4						0,5					
<b>Cooling mode, four pipes<sup>(1)</sup></b>													
Total cooling capacity	kW	NA						1,02	1,16	1,51	1,65	1,80	1,90
Sensible cooling capacity	kW	NA						0,86	0,98	1,30	1,44	1,58	1,69
Water flow	l/s	NA						0,05	0,06	0,08	0,08	0,09	0,09
	l/h	NA						180	200	270	290	320	340
Water pressure drop	kPa	NA						5,4	6,6	10,5	12,4	14,6	16,4
Water volume	l	NA						0,3					
<b>Heating mode, four pipes<sup>(3)</sup></b>													
Heating capacity	kW	NA						1,63	1,84	2,36	2,56	2,76	2,91
Water flow	l/s	NA						0,04	0,04	0,06	0,06	0,07	0,07
	l/h	NA						140	160	210	220	240	260
Water pressure drop	kPa	NA						4,8	5,7	8,3	9,5	10,7	11,6
Water volume	l	NA						0,2					
<b>Electric heater</b>													
		230V ±10% - 1ph - 50Hz						230V ±10% - 1ph - 50Hz					
Maximum capacity	W	1000						1000					
Current input	A	4,6						4,6					
<b>Sound levels</b>													
Sound power level (global)	dB(A)	38	41	48	51	54	57	38	41	48	51	54	57
<b>Electrical data, motor</b>													
Power input	W	28	31	45	54	65	80	28	31	45	54	65	80
Current input	A	0,12	0,14	0,20	0,23	0,28	0,35	0,12	0,14	0,20	0,23	0,28	0,35
FCEER [energy class] - 2 pipes		42 [E]						48 [E]					
FCCOP [energy class]		50 [E]						56 [E]					
FCEER [energy class] - 4 pipes								37 [E]					
FCCOP [energy class]								58 [E]					

Fan speed: L = Low, M = Medium, H = High



Eurovent certified values

- (1) Eurovent conditions: inlet air temperature = 27 °C db/47 % RH – water inlet temperature = 7 °C, water temperature difference = 5 K.  
 (2) Eurovent conditions: inlet air temperature = 20 °C, water inlet temperature = 50 °C, water flow identical to cooling mode.  
 (3) Eurovent conditions: inlet air temperature = 20 °C, water inlet temperature = 70 °C, water temperature difference = 10K.

## 7 - 42NH AND 42NL PERFORMANCE DATA

42NL		229				239				
<b>Fan speed</b>		<b>2V</b>	<b>4V</b>	<b>6V</b>	<b>10V</b>	<b>2V</b>	<b>5V</b>	<b>7V</b>	<b>10V</b>	
(Eurovent certification speeds)		(L)	(M)	(H)	Max	(L)	(M)	(H)	(Max)	
Air flow	l/s	43	58	73	102	43	65	81	102	
	m <sup>3</sup> /h	153	210	261	368	153	234	292	368	
Available static pressure		Pa	0	0	0	0	0	0	0	
<b>Cooling mode, two pipes<sup>(1)</sup></b>										
Total cooling capacity		kW	0,89	1,17	1,41	1,83	1,00	1,48	1,81	2,17
Sensible cooling capacity		kW	0,70	0,94	1,14	1,50	0,76	1,14	1,40	1,71
Water flow	l/s	0,04	0,06	0,07	0,09	0,05	0,07	0,09	0,11	
	l/h	150	200	240	320	170	260	310	380	
Water pressure drop		kPa	9,4	15,7	22,1	33,8	7	14,1	20,3	28,7
Water volume		l	0,4				0,5			
<b>Heating mode, two pipes<sup>(2)</sup></b>										
Heating capacity		kW	1,03	1,37	1,65	2,17	1,13	1,70	2,08	2,55
Water flow	l/s	0,05	0,07	0,08	0,11	0,06	0,08	0,10	0,12	
	l/h	180	240	290	380	200	300	360	440	
Water pressure drop		kPa	11	17,5	23,8	37,9	8,3	15,8	22,2	31,1
Water volume		l	0,4				0,5			
<b>Cooling mode, four pipes<sup>(1)</sup></b>										
Total cooling capacity		kW	NA				0,76	1,12	1,35	1,61
Sensible cooling capacity		kW					0,65	0,96	1,16	1,40
Water flow	l/s	0,04					0,05	0,06	0,08	
	l/h	130					190	230	280	
Water pressure drop		kPa					3,4	6,1	8,3	11,4
Water volume		l	0,3							
<b>Heating mode, four pipes<sup>(3)</sup></b>										
Heating capacity		kW	NA				1,21	1,75	2,09	2,46
Water flow	l/s	0,03					0,04	0,05	0,06	
	l/h	110					150	180	220	
Water pressure drop		kPa					3,3	5,4	6,9	8,9
Water volume		l					0,2			
<b>Electric heater</b>		230V ±10% - 1ph - 50Hz				230V ±10% - 1ph - 50Hz				
Maximum capacity		W	1000				1000			
Current input		A	4,6				4,6			
<b>Sound levels</b>										
Sound power level (global)		dB(A)	32	37	40	48	32	38	41	48
<b>Electrical data, motor</b>										
Power input		W	3	5	7	13	3	5	9	13
Current input		A	0,05	0,06	0,08	0,14	0,05	0,06	0,10	0,14
FCEER [energy class] - 2 pipes		263 [A]				304 [A]				
FCCOP [energy class]		310 [A]				347 [A]				
FCEER [energy class] - 4 pipes						230 [A]				
FCCOP [energy class]						366 [A]				

Fan speed: L = Low, M = Medium, H = High



Eurovent certified values

(1) Eurovent conditions: inlet air temperature = 27 °C db/47 % RH – water inlet temperature = 7 °C, water temperature difference = 5 K.

(2) Eurovent conditions: inlet air temperature = 20 °C, water inlet temperature = 50 °C, water flow identical to cooling mode.

(3) Eurovent conditions: inlet air temperature = 20 °C, water inlet temperature = 70 °C, water temperature difference = 10K.



## 7 - 42NH AND 42NL PERFORMANCE DATA

42NL	325						335						
Fan speed	R6	R5	R4	R3	R2	R1	R6	R5	R4	R3	R2	R1	
(Eurovent certification speeds)	(L)	(M)	(H)			(Max)	(L)	(M)	(H)			(Max)	
Air flow	l/s	84	94	124	144	154	168	84	94	124	144	154	168
	m <sup>3</sup> /h	302	338	447	517	555	606	302	338	447	517	555	606
Available static pressure	Pa	0	0	0	0	0	0	0	0	0	0	0	0
<b>Cooling mode, two pipes<sup>(1)</sup></b>													
Total cooling capacity	kW	1,43	1,56	1,90	2,11	2,20	2,33	1,75	1,94	2,48	2,80	2,95	3,16
Sensible cooling capacity	kW	1,21	1,32	1,65	1,84	1,94	2,06	1,38	1,54	1,98	2,24	2,38	2,56
Water flow	l/s	0,07	0,08	0,09	0,11	0,11	0,12	0,09	0,09	0,12	0,14	0,14	0,16
	l/h	250	270	340	380	390	420	310	340	440	490	520	560
Water pressure drop	kPa	10,5	12,2	17,9	21,3	23,1	25,6	11,6	13,9	22	27,5	30,3	33,8
Water volume	l	0,7						0,9					
<b>Heating mode, two pipes<sup>(2)</sup></b>													
Heating capacity	kW	1,97	2,16	2,67	2,96	3,10	3,27	2,23	2,48	3,17	3,57	3,77	4,02
Water flow	l/s	0,09	0,11	0,13	0,14	0,15	0,16	0,11	0,12	0,15	0,17	0,18	0,19
	l/h	340	380	460	510	540	570	390	430	550	620	660	700
Water pressure drop	kPa	17,9	20,6	28,6	33,6	36,2	39,5	15,3	18,1	27,2	33,3	36,6	40,9
Water volume	l	0,7						0,9					
<b>Cooling mode, four pipes<sup>(1)</sup></b>													
Total cooling capacity	kW	NA						1,75	1,91	2,35	2,60	2,73	2,88
Sensible cooling capacity	kW	NA						1,37	1,50	1,88	2,10	2,21	2,36
Water flow	l/s	NA						0,09	0,09	0,11	0,13	0,13	0,14
	l/h	NA						310	340	410	460	480	510
Water pressure drop	kPa	NA						15,9	18,8	26,9	32	34,7	38,3
Water volume	l	NA						0,6					
<b>Heating mode, four pipes<sup>(3)</sup></b>													
Heating capacity	kW	NA						2,43	2,66	3,21	3,48	3,61	3,78
Water flow	l/s	NA						0,06	0,06	0,08	0,09	0,09	0,09
	l/h	NA						210	230	280	310	320	330
Water pressure drop	kPa	NA						11	12,6	17,2	19,7	20,9	22,5
Water volume	l	NA						0,3					
<b>Electric heater</b>													
		230V ±10% - 1ph - 50Hz						230V ±10% - 1ph - 50Hz					
Maximum capacity	W	1600						1600					
Current input	A	7,3						7,3					
<b>Sound levels</b>													
Sound power level (global)	dB(A)	43	46	54	57	59	61	43	46	54	57	59	61
<b>Electrical data, motor</b>													
Power input	W	38	45	62	74	86	99	38	45	62	74	86	99
Current input	A	0,16	0,20	0,27	0,32	0,37	0,44	0,16	0,20	0,27	0,32	0,37	0,44
FCEER [energy class] - 2 pipes		36 [E]						45 [E]					
FCCOP [energy class]		50 [E]						57 [E]					
FCEER [energy class] - 4 pipes								44 [E]					
FCCOP [energy class]								62 [E]					

Fan speed: L = Low, M = Medium, H = High



Eurovent certified values

(1) Eurovent conditions: inlet air temperature = 27 °C db/47 % RH – water inlet temperature = 7 °C, water temperature difference = 5 K.

(2) Eurovent conditions: inlet air temperature = 20 °C, water inlet temperature = 50 °C, water flow identical to cooling mode.

(3) Eurovent conditions: inlet air temperature = 20 °C, water inlet temperature = 70 °C, water temperature difference = 10K.

## 7 - 42NH AND 42NL PERFORMANCE DATA

42NL		329				339			
<b>Fan speed</b>		<b>2V</b>	<b>4V</b>	<b>6V</b>	<b>10V</b>	<b>2V</b>	<b>5V</b>	<b>7V</b>	<b>10V</b>
(Eurovent certification speeds)		(L)	(M)	(H)	(Max)	(L)	(M)	(H)	(Max)
Air flow	l/s	55	88	120	165	55	88	120	165
	m <sup>3</sup> /h	198	318	431	594	198	318	431	594
Available static pressure	Pa	0	0	0	0	0	0	0	0
<b>Cooling mode, two pipes<sup>(1)</sup></b>									
Total cooling capacity	kW	1,05	1,52	1,89	2,35	1,21	1,87	2,44	3,16
Sensible cooling capacity	kW	0,87	1,29	1,64	2,08	0,95	1,48	1,95	2,56
Water flow	l/s	0,05	0,07	0,09	0,11	0,06	0,09	0,12	0,15
	l/h	180	260	330	410	210	320	420	550
Water pressure drop	kPa	5,9	11,2	17	25	5,9	12,6	20,7	32,9
Water volume	l	0,7				0,9			
<b>Heating mode, two pipes<sup>(2)</sup></b>									
Heating capacity	kW	1,37	2,05	2,60	3,23	1,50	2,34	3,06	3,96
Water flow	l/s	0,07	0,10	0,13	0,16	0,07	0,11	0,15	0,19
	l/h	240	360	450	560	260	410	530	690
Water pressure drop	kPa	10,9	19,1	27,3	38,7	8,2	16,5	25,7	39,8
Water volume	l	0,7				0,9			
<b>Cooling mode, four pipes<sup>(1)</sup></b>									
Total cooling capacity	kW	NA				1,27	1,87	2,36	2,95
Sensible cooling capacity	kW					0,98	1,47	1,89	2,43
Water flow	l/s					0,06	0,09	0,11	0,14
	l/h					220	320	400	510
Water pressure drop	kPa					8	16	25	37
Water volume	l	0,5984							
<b>Heating mode, four pipes<sup>(3)</sup></b>									
Heating capacity	kW	NA				1,95	2,90	3,58	4,27
Water flow	l/s					0,05	0,07	0,09	0,11
	l/h					170	250	310	380
Water pressure drop	kPa					7	13	19	26
Water volume	l					0,3			
<b>Electric heater</b>									
		230V ±10% - 1ph - 50Hz				230V ±10% - 1ph - 50Hz			
Maximum capacity	W	1600				1600			
Current input	A	7,3				7,3			
<b>Sound levels</b>									
Sound power level (global)	dB(A)	37	46	53	60	37	46	53	60
<b>Electrical data, motor</b>									
Power input	W	4	10	20	49	4	10	20	49
Current input	A	0,06	0,10	0,17	0,39	0,06	0,10	0,17	0,39
FCEER [energy class] - 2 pipes		187 [A]				223 [A]			
FCCOP [energy class]		254 [B]				284 [A]			
FCEER [energy class] - 4 pipes						228 [A]			
FCCOP [energy class]						360 [A]			

Fan speed: L = Low, M = Medium, H = High



Eurovent certified values

- (1) Eurovent conditions: inlet air temperature = 27 °C db/47 % RH – water inlet temperature = 7 °C, water temperature difference = 5 K.  
 (2) Eurovent conditions: inlet air temperature = 20 °C, water inlet temperature = 50 °C, water flow identical to cooling mode.  
 (3) Eurovent conditions: inlet air temperature = 20 °C, water inlet temperature = 70 °C, water temperature difference = 10K.

## 7 - 42NH AND 42NL PERFORMANCE DATA

### 7.2 - Physical and electrical data at Eurovent conditions - 42NL - Size 4

#### With G3 filter - without plenum

42NL	425						435						
	R6	R5	R4	R3	R2	R1	R6	R5	R4	R3	R2	R1	
<b>Fan speed</b>													
(Eurovent certification speeds)	(L)	(M)	(H)			(Max)	(L)	(M)	(H)			(Max)	
Air flow	l/s	129	149	209	234	267	301	129	149	209	234	267	301
	m <sup>3</sup> /h	464	537	751	842	960	1085	464	537	751	842	960	1085
Available static pressure	Pa	0	0	0	0	0	0	0	0	0	0	0	0
<b>Cooling mode, two pipes<sup>(1)</sup></b>													
Total cooling capacity	kW	2,37	2,67	3,44	3,70	4,01	4,26	2,69	3,12	4,25	4,67	5,15	5,59
Sensible cooling capacity	kW	1,93	2,19	2,87	3,13	3,43	3,70	2,12	2,45	3,35	3,70	4,13	4,53
Water flow	l/s	0,12	0,13	0,17	0,18	0,20	0,21	0,13	0,15	0,21	0,23	0,25	0,28
	l/h	420	470	610	660	710	760	470	550	750	820	910	990
Water pressure drop	kPa	14,8	18,5	28,3	32,2	36,8	41,2	19,4	25,7	43,7	51,3	60,8	70,2
Water volume	l	1,0						1,3					
<b>Heating mode, two pipes<sup>(2)</sup></b>													
Heating capacity	kW	2,95	3,40	4,61	5,07	5,60	6,09	3,15	3,64	5,04	5,60	6,29	6,97
Water flow	l/s	0,14	0,16	0,22	0,24	0,27	0,29	0,15	0,18	0,24	0,27	0,30	0,34
	l/h	510	590	800	880	970	1060	550	630	880	970	1090	1210
Water pressure drop	kPa	17,70	22,40	37,50	44,10	52,30	60,50	21,70	27,80	48,20	57,90	70,90	84,70
Water volume	l	1,0						1,3					
<b>Cooling mode, four pipes<sup>(1)</sup></b>													
Total cooling capacity	kW	NA						2,46	2,77	3,58	3,88	4,23	4,56
Sensible cooling capacity	kW	NA						1,99	2,25	2,97	3,25	3,58	3,90
Water flow	l/s	NA						0,12	0,14	0,18	0,19	0,21	0,23
	l/h	NA						430	490	630	690	750	810
Water pressure drop	kPa	NA						20,1	24,9	38,5	44,2	51,3	58,7
Water volume	l	NA						0,9					
<b>Heating mode, four pipes<sup>(3)</sup></b>													
Heating capacity	kW	NA						3,17	3,68	5,01	5,50	6,05	6,54
Water flow	l/s	NA						0,08	0,09	0,12	0,13	0,15	0,16
	l/h	NA						280	320	440	480	530	570
Water pressure drop	kPa	NA						18,9	24,3	41,2	48,4	57,1	65,4
Water volume	l	NA						0,5					
<b>Electric heater</b>													
		230V ±10% - 1ph - 50Hz						230V ±10% - 1ph - 50Hz					
Maximum capacity	W	2000						2000					
Current input	A	9,1						9,1					
<b>Sound levels</b>													
Sound power level (global)	dB(A)	45	48	55	58	60	63	45	48	55	58	60	63
<b>Electrical data, motor</b>													
Power input	W	57	69	98	113	129	157	57	69	98	113	129	157
Current input	A	0,25	0,30	0,43	0,49	0,57	0,69	0,25	0,30	0,43	0,49	0,57	0,69
FCEER [energy class] - 2 pipes		40 [E]						46 [E]					
FCCOP [energy class]		51 [E]						54 [E]					
FCEER [energy class] - 4 pipes								42 [E]					
FCCOP [energy class]								55 [E]					

Fan speed: L = Low, M = Medium, H = High



Eurovent certified values

- (1) Eurovent conditions: inlet air temperature = 27 °C db/47 % RH – water inlet temperature = 7 °C, water temperature difference = 5 K.  
 (2) Eurovent conditions: inlet air temperature = 20 °C, water inlet temperature = 50 °C, water flow identical to cooling mode.  
 (3) Eurovent conditions: inlet air temperature = 20 °C, water inlet temperature = 70 °C, water temperature difference = 10K.

## 7 - 42NH AND 42NL PERFORMANCE DATA

42NL		429						439					
<b>Fan speed</b>		<b>2V</b>	<b>3.5V</b>	<b>4V</b>	<b>6V</b>	<b>8V</b>	<b>10V</b>	<b>2V</b>	<b>3.5V</b>	<b>4V</b>	<b>6V</b>	<b>8V</b>	<b>10V</b>
(Eurovent certification speeds)		(L)	(M)	(H)			(Max)	(L)	(M)	(H)			(Max)
Air flow	l/s	67	110	123	169	206	226	67	111	123	169	206	226
	m <sup>3</sup> /h	240	397	444	610	743	814	240	398	444	610	743	814
Available static pressure	Pa	0	0	0	0	0	0	0	0	0	0	0	0
<b>Cooling mode, two pipes<sup>(1)</sup></b>													
Total cooling capacity	kW	1,33	2,09	2,31	2,99	3,43	3,63	1,34	2,32	2,60	3,56	4,22	4,54
Sensible cooling capacity	kW	1,08	1,71	1,89	2,47	2,87	3,06	1,09	1,84	2,05	2,80	3,33	3,60
Water flow	l/s	0,06	0,10	0,11	0,14	0,17	0,18	0,06	0,11	0,13	0,17	0,21	0,22
	l/h	230	360	400	520	600	640	230	400	450	620	740	800
Water pressure drop	kPa	5,3	11,5	13,8	21,9	27,9	31	5,4	14,3	17,7	32,2	42,9	48,8
Water volume	l	1,0						1,3					
<b>Heating mode, two pipes<sup>(2)</sup></b>													
Heating capacity	kW	1,49	2,52	2,82	3,83	4,57	4,93	1,59	2,68	3,00	4,12	4,98	5,42
Water flow	l/s	0,07	0,12	0,14	0,19	0,22	0,24	0,08	0,13	0,14	0,20	0,24	0,26
	l/h	260	440	490	670	800	860	280	470	520	720	870	940
Water pressure drop	kPa	6,1	13,6	16,4	27,3	36,9	42,0	7,3	16,7	20,1	34,2	47,3	54,7
Water volume	l	1,0						1,3					
<b>Cooling mode, four pipes<sup>(1)</sup></b>													
Total cooling capacity	kW	NA						1,40	2,18	2,40	3,09	3,57	3,79
Sensible cooling capacity	kW	NA						1,11	1,76	1,94	2,54	2,96	3,17
Water flow	l/s	NA						0,07	0,11	0,11	0,15	0,18	0,19
	l/h	NA						240	380	410	540	630	670
Water pressure drop	kPa	NA						7,0	15,6	18,6	29,6	37,9	42,3
Water volume	l	NA						0,9					
<b>Heating mode, four pipes<sup>(3)</sup></b>													
Heating capacity	kW	NA						1,50	2,68	3,02	4,15	4,96	5,35
Water flow	l/s	NA						0,04	0,07	0,07	0,10	0,12	0,13
	l/h	NA						130	240	260	360	430	470
Water pressure drop	kPa	NA						5,9	14,4	17,5	29,8	40,5	46,1
Water volume	l	NA						0,5					
<b>Electric heater</b>													
		230V ±10% - 1ph - 50Hz						230V ±10% - 1ph - 50Hz					
Maximum capacity	W	1600						1600					
Current input	A	7,3						7,3					
<b>Sound levels</b>													
Sound power level (global)	dB(A)	38	49	52	60	65	67	38	49	52	60	65	67
<b>Electrical data, motor</b>													
Power input	W	6	15	18	42	78	99	6	14	18	42	78	99
Current input	A	0,07	0,15	0,18	0,38	0,65	0,80	0,07	0,15	0,18	0,38	0,65	0,80
FCEER [energy class] - 2 pipes		173 [B]						189 [A]					
FCCOP [energy class]		205 [B]						225 [B]					
FCEER [energy class] - 4 pipes								187 [A]					
FCCOP [energy class]								218 [B]					

Fan speed: L = Low, M = Medium, H = High



Eurovent certified values

(1) Eurovent conditions: inlet air temperature = 27 °C db/47 % RH – water inlet temperature = 7 °C, water temperature difference = 5 K.

(2) Eurovent conditions: inlet air temperature = 20 °C, water inlet temperature = 50 °C, water flow identical to cooling mode.

(3) Eurovent conditions: inlet air temperature = 20 °C, water inlet temperature = 70 °C, water temperature difference = 10K.

## 7 - 42NH AND 42NL PERFORMANCE DATA

### 7.3 - Physical and electrical data at Eurovent conditions - 42NL - Size 5

With G3 filter - without plenum

42NL	525						535						545												
Fan speed	R6	R5	R4	R3	R2	R1	R6	R5	R4	R3	R2	R1	R6	R5	R4	R3	R2	R1							
(Eurovent certification speeds)	(L)		(M)	(H)		(Max)	(L)		(M)	(H)		(Max)	(L)		(M)	(H)		(Max)							
Air flow	l/s	150	170	233	275	313	359	150	170	233	275	313	359	150	170	233	275	313	359						
	m <sup>3</sup> /h	540	612	840	991	1127	1291	540	612	840	991	1127	1291	540	612	840	991	1127	1291						
Available static pressure	Pa	0	0	0	0	0	0	0	0	0	0	0	0	0	0	0	0	0	0						
<b>Cooling mode, two pipes<sup>(1)</sup></b>																									
Total cooling capacity	kW	2,69	2,97	3,78	4,23	4,61	5,00	3,14	3,54	4,68	5,32	5,80	6,30	NA											
Sensible cooling capacity	kW	2,21	2,46	3,17	3,59	3,95	4,34	2,47	2,78	3,71	4,26	4,70	5,18												
Water flow	l/s	0,13	0,14	0,19	0,21	0,23	0,25	0,15	0,17	0,23	0,26	0,28	0,31												
	l/h	470	520	670	750	810	890	550	620	820	930	1020	1110												
Water pressure drop	kPa	16,8	20,3	31,3	37,9	43,9	50,8	21	26,4	43,7	54	62,9	72,7												
Water volume	l	1,4						1,8																	
<b>Heating mode, two pipes<sup>(2)</sup></b>																									
Heating capacity	kW	3,45	3,87	5,08	5,75	6,27	6,80	3,56	4,04	5,41	6,14	6,68	7,18	NA											
Water flow	l/s	0,17	0,19	0,24	0,28	0,30	0,33	0,17	0,19	0,26	0,30	0,32	0,35												
	l/h	600	670	880	1000	1090	1180	620	700	940	1070	1160	1250												
Water pressure drop	kPa	21,6	26,1	41,5	51,3	59,5	68,6	25,3	31,3	51,4	64	74	83,8												
Water volume	l	1,4						1,8																	
<b>Cooling mode, four pipes<sup>(1)</sup></b>																									
Total cooling capacity	kW	NA						2,70	3,00	3,86	4,33	4,71	5,11	2,92	3,27	4,32	4,93	5,44	5,98						
Sensible cooling capacity	kW							2,20	2,45	3,19	3,62	3,98	4,37	2,35	2,64	3,51	4,04	4,49	4,99						
Water flow	l/s							0,13	0,15	0,19	0,21	0,23	0,25	0,14	0,16	0,21	0,24	0,27	0,29						
	l/h							470	530	680	760	830	910	510	570	760	870	960	1060						
Water pressure drop	kPa							17,9	22	34,3	41,8	48,3	55,8	18	22,4	37,4	47	55,5	65,6						
Water volume	l													1,1						1,4					
<b>Heating mode, four pipes<sup>(3)</sup></b>																									
Heating capacity	kW	NA						2,99	3,29	4,14	4,60	4,95	5,32	3,44	3,86	5,00	5,57	5,96	6,31						
Water flow	l/s							0,07	0,08	0,10	0,11	0,12	0,13	0,08	0,09	0,12	0,14	0,14	0,15						
	l/h							260	290	360	400	430	470	300	340	440	490	520	550						
Water pressure drop	kPa							5,9	6,8	9,6	11,4	12,8	14,4	6,8	8,1	12,1	14,3	16	17,6						
Water volume	l													0,5						0,6					
<b>Electric heater</b>																									
		230V ±10% - 1ph - 50Hz						230V ±10% - 1ph - 50Hz						230V ±10% - 1ph - 50Hz											
Maximum capacity	W	2000						2000						2000											
Current input	A	9,1						9,1						9,1											
<b>Sound levels</b>																									
Sound power level (global)	dB(A)	42	46	53	57	59	62	42	46	53	57	59	62	42	46	53	57	59	62						
<b>Electrical data, motor</b>																									
Power input	W	58	67	99	118	137	170	58	67	99	118	137	170	58	67	99	118	137	170						
Current input	A	0,26	0,30	0,43	0,52	0,60	0,74	0,26	0,30	0,43	0,52	0,60	0,74	0,26	0,30	0,43	0,52	0,60	0,74						
FCEER [energy class] - 2 pipes		42 [E]						51 [E]																	
FCCOP [energy class]		56 [E]						58 [E]																	
FCEER [energy class] - 4 pipes								43 [E]						47 [E]											
FCCOP [energy class]								47 [E]						55 [E]											

Fan speed: L = Low, M = Medium, H = High



Eurovent certified values

- (1) Eurovent conditions: inlet air temperature = 27 °C db/47 % RH – water inlet temperature = 7 °C, water temperature difference = 5 K.
- (2) Eurovent conditions: inlet air temperature = 20 °C, water inlet temperature = 50 °C, water flow identical to cooling mode.
- (3) Eurovent conditions: inlet air temperature = 20 °C, water inlet temperature = 70 °C, water temperature difference = 10K.



## 7 - 42NH AND 42NL PERFORMANCE DATA

42NL	529						539						549						
Fan speed	2V	4V	5V	6V	8V	10V	2V	4V	5.5V	6V	8V	10V	2V	4V	5.5V	6V	8V	10V	
(Eurovent certification speeds)	(L)		(M)	(H)		(Max)	(L)		(M)	(H)		(Max)	(L)		(M)	(H)		(Max)	
Air flow	l/s	82	141	172	188	231	255	82	141	179	187	230	254	81	140	179	187	230	254
	m <sup>3</sup> /h	294	508	618	675	831	918	294	507	645	673	828	915	290	505	644,5	674	829	916
Available static pressure	Pa	0	0	0	0	0	0	0	0	0	0	0	0	0	0	0	0	0	0
<b>Cooling mode, two pipes<sup>(1)</sup></b>																			
Total cooling capacity	kW	1,65	2,60	3,04	3,26	3,80	4,06	1,70	2,99	3,78	3,93	4,69	5,06	NA					
Sensible cooling capacity	kW	1,33	2,14	2,52	2,71	3,19	3,44	1,36	2,36	2,98	3,10	3,72	4,04						
Water flow	l/s	0,08	0,13	0,15	0,16	0,18	0,20	0,08	0,14	0,18	0,19	0,23	0,24						
	l/h	280	450	530	560	660	710	290	520	650	680	810	880						
Water pressure drop	kPa	6,8	15,3	20,6	23,5	30,8	34,7	6,7	18,6	29,1	31,5	42,9	48,9						
Water volume	l	1,4						1,8											
<b>Heating mode, two pipes<sup>(2)</sup></b>																			
Heating capacity	kW	1,90	3,25	3,90	4,22	5,03	5,43	1,70	3,32	4,26	4,44	5,35	5,79	NA					
Water flow rate	l/s	0,09	0,16	0,19	0,20	0,24	0,26	0,08	0,16	0,21	0,21	0,26	0,28						
	l/h	330	570	680	730	870	940	300	580	740	770	930	1010						
Water pressure drop	kPa	8,3	19,6	26,5	30,3	40,7	46,5	7,6	22,6	34,2	36,7	50,4	57,9						
Water volume	l	1,4						1,8											
<b>Cooling mode, four pipes<sup>(1)</sup></b>																			
Total cooling capacity	kW	NA						1,59	2,60	3,19	3,31	3,88	4,15	1,64	2,79	3,49	3,63	4,33	4,69
Sensible cooling capacity	kW							1,29	2,12	2,62	2,72	3,21	3,46	1,33	2,25	2,83	2,94	3,53	3,84
Water flow	l/s							0,08	0,13	0,15	0,16	0,19	0,20	0,08	0,13	0,17	0,18	0,21	0,23
	l/h							270	450	550	570	670	720	280	480	605	630	750	810
Water pressure drop	kPa							6,7	16,2	24	25,7	33,8	38,2	6,3	16,1	24,65	26,6	36,7	42,5
Water volume	l							1,1						1,4					
<b>Heating mode, four pipes<sup>(3)</sup></b>																			
Heating capacity	kW	NA						1,80	2,84	3,43	3,54	4,10	4,38	1,76	3,23	4,04	4,20	4,95	5,31
Water flow	l/s							0,04	0,07	0,08	0,09	0,10	0,11	0,04	0,08	0,10	0,10	0,12	0,13
	l/h							160	250	300	310	360	380	150	280	355	370	430	470
Water pressure drop	kPa							3	5,5	7,2	7,6	9,5	10,5	2,7	6,2	8,65	9,2	11,9	13,3
Water volume	l													0,5					
<b>Electric heater</b>																			
		230V ±10% - 1ph - 50Hz						230V ±10% - 1ph - 50Hz						230V ±10% - 1ph - 50Hz					
Maximum capacity	W	2000						2000						2000					
Current input	A	9,1						9,1						9,1					
<b>Sound levels</b>																			
Sound power level (global)	dB(A)	32	43	47	51	55	58	32	43	49	51	55	58	32	43	49	51	55	58
<b>Electrical data, motor</b>																			
Power input	W	4	11	18	24	43	58	4	11	21	24	43	58	4	11	21	24	43	58
Current input	A	0,04	0,09	0,13	0,17	0,28	0,39	0,04	0,09	0,15	0,17	0,28	0,39	0,04	0,09	0,15	0,17	0,28	0,39
FCEER [energy class] - 2 pipes		233 [A]						241 [A]											
FCCOP [energy class]		296 [A]						268 [A]											
FCEER [energy class] - 4 pipes								213 [A]						227 [A]					
FCCOP [energy class]								248 [B]						265 [A]					

Fan speed: L = Low, M = Medium, H = High



Eurovent certified values

- (1) Eurovent conditions: inlet air temperature = 27 °C db/47 % RH – water inlet temperature = 7 °C, water temperature difference = 5 K.  
 (2) Eurovent conditions: inlet air temperature = 20 °C, water inlet temperature = 50 °C, water flow identical to cooling mode.  
 (3) Eurovent conditions: inlet air temperature = 20 °C, water inlet temperature = 70 °C, water temperature difference = 10K.

## 7 - 42NH AND 42NL PERFORMANCE DATA

### 7.4 - Physical and electrical data at Eurovent conditions - 42NH - Sizes 2 and 3

#### With G3 filter - without plenum

42NH	225					235					229				
Fan speed	R5	R4	R3	R2	R1	R5	R4	R3	R2	R1	2V	7V	8V	10V	
(Eurovent certification speeds)	(L)			(M)	(H)	(L)			(M)	(H)	(L)	(M)	(H)		
Air flow	I/s	23	47	58	63	76	23	47	58	63	76	25	64	70	81,11
	m <sup>3</sup> /h	81	170	209	228	272	81	170	209	228	272	91	229	253	292
Available static pressure	Pa	6	28	42	50	71	6	28	42	50	71	8	50	61	81
<b>Cooling mode, two pipes<sup>(1)</sup></b>															
Total cooling capacity	kW	0,48	0,96	1,14	1,22	1,42	0,54	1,10	1,32	1,42	1,66	0,55	1,26	1,36	1,52
Sensible cooling capacity	kW	0,37	0,76	0,90	0,97	1,14	0,40	0,84	1,00	1,08	1,28	0,43	1,00	1,09	1,23
Water flow	I/s	0,02	0,05	0,06	0,06	0,07	0,03	0,05	0,06	0,07	0,08	0,03	0,06	0,07	0,075
	I/h	80	170	200	220	250	90	190	230	250	290	90	220	240	270
Water pressure drop	kPa	3,6	11,2	15,6	17,9	23,3	3,4	8,5	11,9	13,7	18,2	4,3	18	21,1	25,5
Water volume	l	0,4					0,5					0,4			
<b>Heating mode, two pipes<sup>(2)</sup></b>															
Heating capacity	kW	0,57	1,14	1,37	1,47	1,71	0,62	1,27	1,54	1,67	1,96	0,64	1,48	1,61	1,81
Water flow	I/s	0,03	0,06	0,07	0,07	0,08	0,03	0,06	0,08	0,08	0,09	0,03	0,07	0,08	0,086
	I/h	100	200	240	260	300	110	220	270	290	340	110	260	280	310
Water pressure drop	kPa	4,5	12,9	17,4	19,6	25,2	3,3	10	13,5	15,4	20	5,4	19,8	22,8	27,9
Water volume	l	0,4					0,5					0,4			
<b>Cooling mode, four pipes<sup>(1)</sup></b>															
Total cooling capacity	kW	NA					0,44	0,84	0,99	1,07	1,24	NA			
Sensible cooling capacity	kW						0,36	0,71	0,84	0,90	1,06				
Water flow	I/s						0,02	0,04	0,05	0,05	0,06				
	I/h						80	150	180	190	220				
Water pressure drop	kPa						2,3	4	5,20	5,9	7,6				
Water volume	l	0,3													
<b>Heating mode, four pipes<sup>(3)</sup></b>															
Heating capacity	kW	NA					0,68	1,35	1,61	1,72	1,98	NA			
Water flow	I/s						0,02	0,03	0,04	0,04	0,05				
	I/h						60	120	140	150	170				
Water pressure drop	kPa						1,8	3,8	4,7	5,2	6,4				
Water volume	l						0,2								
<b>Electric heater</b>															
Maximum capacity	W	230V ±10%					230V ±10%					230V ±10%			
Current input	A	1000					1000					1000			
		4,6					4,6					4,6			
<b>Sound levels</b>															
Sound power level (return and radiated)	dB(A)	32	43	48	49	53	32	43	48	49	53	36	50	52	56
Sound power level (supply)	dB(A)	31	40	46	49	52	31	40	46	49	52	37	51	53	58
<b>Electrical data, motor</b>															
Power input	W	13	20	41	43	44	13	20	41	43	44	3	18	22	33
Current input	A	0,13	0,16	0,22	0,23	0,24	0,13	0,16	0,22	0,23	0,24	0,05	0,22	0,28	0,39
FCEER [energy class] - 2 pipes		37 [D]					43 [C]					95 [A]			
FCCOP [energy class]		46 [C]					51 [C]					117 [A]			
FCEER [energy class] - 4 pipes							33 [D]								
FCCOP [energy class]							54 [C]								

Fan speed: L = Low, M = Medium, H = High



Eurovent certified values

- (1) Eurovent conditions: inlet air temperature = 27 °C db/47 % RH – water inlet temperature = 7 °C, water temperature difference = 5 K.  
 (2) Eurovent conditions: inlet air temperature = 20 °C, water inlet temperature = 50 °C, water flow identical to cooling mode.  
 (3) Eurovent conditions: inlet air temperature = 20 °C, water inlet temperature = 70 °C, water temperature difference = 10K.

## 7 - 42NH AND 42NL PERFORMANCE DATA

42NH	239				279				289				
<b>Fan speed</b>	<b>2V</b>	<b>7V</b>	<b>8V</b>	<b>10V</b>	<b>2V</b>	<b>6V</b>	<b>7V</b>	<b>10V</b>	<b>2V</b>	<b>6V</b>	<b>7V</b>	<b>10V</b>	
(Eurovent certification speeds)	(L)	(M)	(H)		(L)	(M)	(H)		(L)	(M)	(H)		
Air flow	l/s	25	64	70	81	32	85	97	124	36	96	108	134
	m <sup>3</sup> /h	91	229	253	292	116	305	349	446	128	347	387	481
Available static pressure	Pa	8	50	61	81	7	50	65	107	7	50	62	96
<b>Cooling mode, two pipes<sup>(1)</sup></b>													
Total cooling capacity	kW	0,62	1,45	1,58	1,78	0,78	1,86	2,07	2,45	1,00	2,44	2,67	3,15
Sensible cooling capacity	kW	0,46	1,11	1,22	1,38	0,59	1,44	1,61	1,94	0,71	1,79	1,97	2,35
Water flow	l/s	0,03	0,07	0,08	0,09	0,04	0,09	0,10	0,12	0,05	0,12	0,13	0,16
	l/h	110	250	280	310	130	320	360	430	170	420	470	560
Water pressure drop	kPa	3,7	13,8	16,2	20,4	4,7	21,9	26,9	36,1	4,4	21	25,1	33,5
Water volume	l	0,5				0,5				0,6			
<b>Heating mode, two pipes<sup>(2)</sup></b>													
Heating capacity	kW	0,70	1,68	1,84	2,09	0,88	2,17	2,44	2,98	1,05	2,78	3,09	3,79
Water flow	l/s	0,03	0,08	0,09	0,10	0,04	0,11	0,12	0,14	0,05	0,13	0,15	0,18
	l/h	120	290	320	360	150	380	420	520	180	480	540	660
Water pressure drop	kPa	3,9	15,5	18	22,2	5,7	23,7	28,9	40,7	4,9	23,3	27,8	39,5
Water volume	l	0,5				0,5				0,6			
<b>Cooling mode, four pipes<sup>(1)</sup></b>													
Total cooling capacity	kW	0,49	1,10	1,19	1,33	0,60	1,39	1,53	1,79	0,94	2,17	2,35	2,72
Sensible cooling capacity	kW	0,41	0,93	1,01	1,14	0,50	1,19	1,32	1,57	0,68	1,66	1,81	2,13
Water flow	l/s	0,02	0,05	0,06	0,06	0,03	0,07	0,08	0,09	0,04	0,11	0,11	0,13
	l/h	80	190	210	230	100	240	270	320	160	380	410	480
Water pressure drop	kPa	2,4	6	6,8	8,4	2,8	8,9	10,7	14,5	5,9	26	30	39
Water volume	l	0,3				0,3				0,4			
<b>Heating mode, four pipes<sup>(3)</sup></b>													
Heating capacity	kW	0,77	1,73	1,88	2,09	0,96	2,16	2,37	2,75	0,97	2,29	2,53	3,09
Water flow	l/s	0,02	0,04	0,04	0,05	0,02	0,05	0,06	0,07	0,03	0,06	0,06	0,08
	l/h	70	150	160	180	80	190	210	240	90	200	220	270
Water pressure drop	kPa	2	5,3	5,9	6,9	2,5	7,3	8,4	10,6	2,5	7,8	9,1	12,5
Water volume	l	0,2				0,2				0,3			
<b>Electric heater</b>													
Maximum capacity	W	230V ±10%				230V ±10%				230V ±10%			
Current input	A	1000				1000				1000			
		4,6				4,6				4,6			
<b>Sound levels</b>													
Sound power level (return and radiated)	dB(A)	36	50	52	56	34	52	54	61	36	54	57	61
Sound power level (supply)	dB(A)	37	51	53	58	34	55	58	64	35	56	59	65
<b>Electrical data, motor</b>													
Power input	W	3	18	22	33	4	25	36	70	7	36	49	50
Current input	A	0,05	0,22	0,28	0,39	0,06	0,29	0,40	0,75	0,08	0,31	0,40	0,91
FCEER [energy class] - 2 pipes		109[A]				98 [A]				85 [A]			
FCCOP [energy class]		130 [A]				118 [A]				97 [A]			
FCEER [energy class] - 4 pipes		84 [B]				74 [B]				78 [B]			
FCCOP [energy class]		138 [A]				123 [A]				84 [B]			

Fan speed: L = Low, M = Medium, H = High



Eurovent certified values

- (1) Eurovent conditions: inlet air temperature = 27 °C db/47 % RH – water inlet temperature = 7 °C, water temperature difference = 5 K.  
 (2) Eurovent conditions: inlet air temperature = 20 °C, water inlet temperature = 50 °C, water flow identical to cooling mode.  
 (3) Eurovent conditions: inlet air temperature = 20 °C, water inlet temperature = 70 °C, water temperature difference = 10K.

## 7 - 42NH AND 42NL PERFORMANCE DATA

42NH	325					335					
<b>Fan speed</b>	<b>R5</b>	<b>R4</b>	<b>R3</b>	<b>R2</b>	<b>R1</b>	<b>R5</b>	<b>R4</b>	<b>R3</b>	<b>R2</b>	<b>R1</b>	
(Eurovent certification speeds)		(L)	(M)	(H)	Max		(L)	(M)	(H)	Max	
Air flow	l/s	55	79	102	131	160	55	79	102	131	160
	m <sup>3</sup> /h	197	284	366	471	577	197	284	366	471	577
Available static pressure	Pa	14	30	50	83	124	14	30	50	83	124
<b>Cooling mode, two pipes<sup>(1)</sup></b>											
Total cooling capacity	kW	0,94	1,27	1,55	1,87	2,16	1,10	1,57	1,98	2,48	2,95
Sensible cooling capacity	kW	0,76	1,06	1,31	1,61	1,89	0,84	1,22	1,55	1,96	2,36
Water flow	l/s	0,05	0,07	0,08	0,10	0,11	0,06	0,08	0,10	0,13	0,15
	l/h	180	240	290	350	400	210	290	370	460	540
Water pressure drop	kPa	5,9	9,6	13,6	19,1	24,2	5	9	15	23	31
Water volume	l	0,7					0,9				
<b>Heating mode, two pipes<sup>(2)</sup></b>											
Heating capacity	kW	1,36	1,87	2,30	2,77	3,18	0,57	2,11	2,66	3,30	3,88
Water flow	l/s	0,07	0,09	0,11	0,13	0,15	0,07	0,10	0,13	0,16	0,19
	l/h	240	320	400	480	550	260	370	460	570	680
Water pressure drop	kPa	10,9	16,7	22,7	30,3	37,7	8,2	13,9	20,3	29,2	38,5
Water volume	l	0,7					0,9				
<b>Cooling mode, four pipes<sup>(1)</sup></b>											
Total cooling capacity	kW	NA					1,15	1,58	1,94	2,34	2,70
Sensible cooling capacity	kW	NA					0,86	1,21	1,51	1,86	2,18
Water flow	l/s	NA					0,06	0,08	0,10	0,12	0,14
	l/h	NA					220	290	360	430	500
Water pressure drop	kPa	NA					8,5	14,5	21,0	28,6	36,3
Water volume	l	NA					0,6				
<b>Heating mode, four pipes<sup>(3)</sup></b>											
Heating capacity	kW	NA					1,71	2,32	2,81	3,31	3,69
Water flow	l/s	NA					0,04	0,06	0,07	0,08	0,09
	l/h	NA					150	200	250	290	320
Water pressure drop	kPa	NA					6,4	10,2	13,8	18	21,6
Water volume	l	NA					0,3				
<b>Electric heater</b>											
		230V ±10% - 1ph - 50Hz					230V ±10% - 1ph - 50Hz				
Maximum capacity	W	1600					1600				
Current input	A	7,3					7,3				
<b>Sound levels</b>											
Sound power level (return and radiated)	dB(A)	42	45	49	56	60	42	45	49	56	60
Sound power level (supply)	dB(A)	46	48	54	61	66	46	48	54	61	66
<b>Electrical data, motor</b>											
Power input	W	109	126	146	168	190	109	126	146	168	190
Current input	A	0,50	0,57	0,65	0,75	0,88	0,50	0,57	0,65	0,75	0,88
FCEER [energy class] - 2 pipes		10 [E]					13 [E]				
FCCOP [energy class]		15 [E]					17 [E]				
FCEER [energy class] - 4 pipes							13 [E]				
FCCOP [energy class]							19 [E]				

Fan speed: L = Low, M = Medium, H = High



Eurovent certified values

- (1) Eurovent conditions: inlet air temperature = 27 °C db/47 % RH – water inlet temperature = 7 °C, water temperature difference = 5 K.  
 (2) Eurovent conditions: inlet air temperature = 20 °C, water inlet temperature = 50 °C, water flow identical to cooling mode.  
 (3) Eurovent conditions: inlet air temperature = 20 °C, water inlet temperature = 70 °C, water temperature difference = 10K.

## 7 - 42NH AND 42NL PERFORMANCE DATA

42NH	329				339				
	2V	3.7V	4.5V	10V	2V	3.7V	4.5V	10V	
<b>Fan speed</b>									
(Eurovent certification speeds)	(L)	(M)	(H)	Max	(L)	(M)	(H)	Max	
Air flow	l/s	59	125	147	212	59	124	146	212
	m <sup>3</sup> /h	213	450	528	764	212	447	527	763
Available static pressure	Pa	11	50,1	69	143	11	50	70	145
<b>Cooling mode, two pipes<sup>(1)</sup></b>									
Total cooling capacity	kW	1,11	1,93	2,15	2,64	1,29	2,50	2,85	3,70
Sensible cooling capacity	kW	0,92	1,68	1,89	2,38	1,01	2,00	2,29	3,04
Water flow	l/s	0,05	0,10	0,11	0,13	0,06	0,12	0,14	0,19
	l/h	190	342	380	480	220	433	500	670
Water pressure drop	kPa	6,5	18	22	32,7	6,6	22	28	45,3
Water volume	l	0,7				0,9			
<b>Heating mode, two pipes<sup>(2)</sup></b>									
Heating capacity	kW	1,46	2,68	3,01	3,74	1,61	3,16	3,61	4,70
Water flow	l/s	0,07	0,13	0,14	0,18	0,08	0,15	0,17	0,23
	l/h	250	466	520	650	280	547	625	820
Water pressure drop	kPa	11,9	28,7	34,3	49,2	9,0	27,2	34,1	53,5
Water volume	l	0,7				0,9			
<b>Cooling mode, four pipes<sup>(1)</sup></b>									
Total cooling capacity	kW	NA				1,22	2,38	2,65	3,30
Sensible cooling capacity	kW					1,03	1,90	2,15	2,75
Water flow	l/s					0,06	0,11	0,13	0,17
	l/h					230	410	470	600
Water pressure drop	kPa					9,5	26,8	32,6	49,6
Water volume	l	0,6							
<b>Heating mode, four pipes<sup>(3)</sup></b>									
Heating capacity	kW	NA				1,82	3,20	3,51	4,34
Water flow	l/s					0,04	0,08	0,08	0,11
	l/h					160	278	305	380
Water pressure drop	kPa					7,0	17,14	19,9	28,6
Water volume	l					0,3			
<b>Electric heater</b>									
		230V ±10% - 1ph - 50Hz				230V ±10% - 1ph - 50Hz			
Maximum capacity	W	1600				1600			
Current input	A	7,3				7,3			
<b>Sound levels</b>									
Sound power level (return and radiated)	dB(A)	37	54	58	67	37	54	58	67
Sound power level (supply)	dB(A)	40	59	63	71	40	59	63	71
<b>Electrical data, motor</b>									
Power input	W	8	37	58,5	174	8	37	58,5	172
Current input	A	0,11	0,57	0,79	1,35	0,11	0,57	0,79	1,35
FCEER [energy class] - 2 pipes		73 [B]				90 [A]			
FCCOP [energy class]		104 [A]				118 [A]			
FCEER [energy class] - 4 pipes						85 [A]			
FCCOP [energy class]						127 [A]			

Fan speed: L = Low, M = Medium, H = High



Eurovent certified values

- (1) Eurovent conditions: inlet air temperature = 27 °C db/47 % RH – water inlet temperature = 7 °C, water temperature difference = 5 K.  
 (2) Eurovent conditions: inlet air temperature = 20 °C, water inlet temperature = 50 °C, water flow identical to cooling mode.  
 (3) Eurovent conditions: inlet air temperature = 20 °C, water inlet temperature = 70 °C, water temperature difference = 10K.



## 7 - 42NH AND 42NL PERFORMANCE DATA

### 7.5 - Physical and electrical data at Eurovent conditions - 42NH - Size 4

With G3 filter - without plenum

42NH		425					435					
<b>Fan speed</b>		<b>R5</b>	<b>R4</b>	<b>R3</b>	<b>R2</b>	<b>R1</b>	<b>R5</b>	<b>R4</b>	<b>R3</b>	<b>R2</b>	<b>R1</b>	
(Eurovent certification speeds)		(L)	(M)	(H)		Max	(L)	(M)	(H)		Max	
Air flow	l/s	89	140	166	189	197	89	140	166	189	197	
	m <sup>3</sup> /h	320	505	599	679	709	320	505	599	679	709	
Available static pressure		Pa	20	50	70	90	98	20	50	70	90	98
<b>Cooling mode, two pipes<sup>(1)</sup></b>												
Total cooling capacity	kW	1,72	2,60	3,01	3,30	3,40	1,84	3,07	3,62	4,02	4,14	
Sensible cooling capacity	kW	1,37	2,10	2,44	2,71	2,80	1,44	2,36	2,79	3,12	3,22	
Water flow	l/s	0,09	0,13	0,15	0,16	0,17	0,09	0,15	0,18	0,20	0,20	
	l/h	310	460	530	580	600	330	540	640	710	730	
Water pressure drop	kPa	8,7	18	22,6	26,5	28	10	25,1	33,9	40	42,1	
Water volume	l	1,0					1,3					
<b>Heating mode, two pipes<sup>(2)</sup></b>												
Heating capacity	kW	1,98	3,16	3,75	4,22	4,39	2,02	3,32	3,99	4,53	4,72	
Water flow	l/s	0,09	0,15	0,18	0,20	0,21	0,10	0,16	0,19	0,22	0,23	
	l/h	340	550	650	730	760	350	580	690	790	820	
Water pressure drop	kPa	9,3	19,8	26,3	32,2	34,5	10,6	23,8	32,4	40,2	43,2	
Water volume	l	1,0					1,3					
<b>Cooling mode, four pipes<sup>(1)</sup></b>												
Total cooling capacity	kW	NA					1,76	2,66	3,06	3,36	3,45	
Sensible cooling capacity	kW	NA					1,39	2,14	2,49	2,75	2,84	
Water flow	l/s	NA					0,09	0,13	0,15	0,16	0,17	
	l/h	NA					320	470	540	590	610	
Water pressure drop	kPa	NA					11,3	23,5	29,8	34,7	36,5	
Water volume	l	NA					0,9					
<b>Heating mode, four pipes<sup>(3)</sup></b>												
Heating capacity	kW	NA					2,13	3,51	4,14	4,64	4,81	
Water flow	l/s	NA					0,05	0,09	0,10	0,11	0,12	
	l/h	NA					190	310	360	410	420	
Water pressure drop	kPa	NA					10	22,4	29,7	36	38,3	
Water volume	l	NA					0,5					
<b>Electric heater</b>		230V ±10% - 1ph - 50Hz										
Maximum capacity	W	2000					2000					
Current input	A	9,1					9,1					
<b>Sound levels</b>												
Sound power level (return and radiated)	dB(A)	43	51	55	57	58	43	51	55	57	58	
Sound power level (supply)	dB(A)	47	54	58	60	61	47	54	58	60	61	
<b>Electrical data, motor</b>												
Power input	W	79	87	94	103	117	79	87	94	103	117	
Current input	A	0,43	0,51	0,62	0,67	0,72	0,43	0,51	0,62	0,67	0,72	
FCEER [energy class] - 2 pipes		25 [E]					28 [D]					
FCCOP [energy class]		29 [D]					30 [D]					
FCEER [energy class] - 4 pipes							26 [D]					
FCCOP [energy class]							32 [D]					

Fan speed: L = Low, M = Medium, H = High



Eurovent certified values

- (1) Eurovent conditions: inlet air temperature = 27 °C db/47 % RH – water inlet temperature = 7 °C, water temperature difference = 5 K.  
 (2) Eurovent conditions: inlet air temperature = 20 °C, water inlet temperature = 50 °C, water flow identical to cooling mode.  
 (3) Eurovent conditions: inlet air temperature = 20 °C, water inlet temperature = 70 °C, water temperature difference = 10K.

## 7 - 42NH AND 42NL PERFORMANCE DATA

42NH		429					439				
<b>Fan speed</b>		<b>2V</b>	<b>3.7V</b>	<b>5V</b>	<b>7V</b>	<b>9V</b>	<b>2V</b>	<b>3.7V</b>	<b>5V</b>	<b>7V</b>	<b>9V</b>
(Eurovent certification speeds)		(L)	(M)	(H)		Max	(L)	(M)	(H)		Max
Air flow	l/s	61	129	159	212	219	61	129	159	212	219
	m <sup>3</sup> /h	218	464,2	574	764	787	218	464,2	574	764	787
Available static pressure	Pa	11	50,4	76	135	143	11	50,4	76	135	143
<b>Cooling mode, two pipes<sup>(1)</sup></b>											
Total cooling capacity	kW	1,26	2,46	2,90	3,56	3,61	1,22	2,85	3,50	4,31	4,35
Sensible cooling capacity	kW	1,00	1,99	2,37	2,95	2,99	0,99	2,21	2,70	3,38	3,42
Water flow	l/s	0,06	0,12	0,14	0,18	0,18	0,06	0,14	0,17	0,21	0,22
	l/h	220	426	510	640	650	210	494	610	770	780
Water pressure drop	kPa	4,8	15,82	21,3	30,7	31,7	4,8	21,51	31,9	45,6	46,7
Water volume	l	1,0					1,3				
<b>Heating mode, two pipes<sup>(2)</sup></b>											
Heating capacity	kW	1,34	2,91	3,59	4,69	4,80	1,38	3,03	3,81	5,05	5,17
Water flow	l/s	0,06	0,14	0,17	0,23	0,23	0,07	0,15	0,18	0,24	0,25
	l/h	230	504	620	820	830	240	528	660	880	900
Water pressure drop	kPa	5,2	17,31	24,5	38,5	40,1	5,8	20,57	29,9	48,4	50,5
Water volume	l	1,0					1,3				
<b>Cooling mode, four pipes<sup>(1)</sup></b>											
Total cooling capacity	kW	NA					1,28	2,52	2,97	3,59	3,63
Sensible cooling capacity	kW						1,02	2,03	2,41	2,97	3,01
Water flow	l/s						0,06	0,12	0,14	0,18	0,18
	l/h						220	436	520	640	650
Water pressure drop	kPa						6,1	20,71	28,4	39,6	40,7
Water volume	l	0,9									
<b>Heating mode, four pipes<sup>(3)</sup></b>											
Heating capacity	kW	NA					1,34	3,21	3,97	5,10	5,21
Water flow	l/s						0,03	0,08	0,10	0,13	0,13
	l/h						120	279	350	450	460
Water pressure drop	kPa						5	19,45	27,7	42,5	44,1
Water volume	l						0,5				
<b>Electric heater</b>											
		230V ±10% - 1ph - 50Hz					230V ±10% - 1ph - 50Hz				
Maximum capacity	W	1600					1600				
Current input	A	7,3					7,3				
<b>Sound levels</b>											
Sound power level (return and radiated)	dB(A)	37	54	60	66	66	37	54	60	66	66
Sound power level (supply)	dB(A)	40	62	67	72	72	40	62	67	72	72
<b>Electrical data, motor</b>											
Power input	W	8	36,3	74	147	174	8	36,3	74	147	174
Current input	A	0,12	0,43	0,98	1,26	1,31	0,12	0,43	0,98	1,26	1,31
FCEER [energy class] - 2 pipes		86 [A]					92 [A]				
FCCOP [energy class]		100 [A]					104 [A]				
FCEER [energy class] - 4 pipes							88 [A]				
FCCOP [energy class]							106 [A]				

Fan speed: L = Low, M = Medium, H = High



Eurovent certified values

- (1) Eurovent conditions: inlet air temperature = 27 °C db/47 % RH – water inlet temperature = 7 °C, water temperature difference = 5 K.  
 (2) Eurovent conditions: inlet air temperature = 20 °C, water inlet temperature = 50 °C, water flow identical to cooling mode.  
 (3) Eurovent conditions: inlet air temperature = 20 °C, water inlet temperature = 70 °C, water temperature difference = 10K.

## 7 - 42NH AND 42NL PERFORMANCE DATA

### 7.6 - Physical and electrical data at Eurovent conditions - 42NH - Size 5

With G3 filter - without plenum

42NH	525					535					545					
Fan speed	R5	R4	R3	R2	R1	R5	R4	R3	R2	R1	R5	R4	R3	R2	R1	
(Eurovent certification speeds)	(L)	(M)	(H)		Max	(L)	(M)	(H)		Max	(L)	(M)	(H)		Max	
Air flow	l/s	213	240	257	268	279	213	240	257	268	279	213	240	257	268	279
	m <sup>3</sup> /h	767	863	924	964	1004	767	863	924	964	1004	767	863	925	964	1004
Available static pressure	Pa	40	50	57	62	68	40	50	57	62	68	40	50	57	62	68
<b>Cooling mode, two pipes<sup>(1)</sup></b>																
Total cooling capacity	kW	3,52	3,84	4,03	4,15	4,25	4,33	4,77	5,05	5,21	5,36	NA				
Sensible cooling capacity	kW	2,94	3,23	3,41	3,51	3,62	3,41	3,79	4,02	4,16	4,29					
Water flow	l/s	0,17	0,19	0,20	0,20	0,21	0,21	0,23	0,25	0,26	0,26					
	l/h	620	680	710	730	750	760	840	890	920	940					
Water pressure drop	kPa	28,5	32,3	35	36,8	38,5	38,2	45,3	49,6	52,3	55					
Water volume	l	1,4					1,8									
<b>Heating mode, two pipes<sup>(2)</sup></b>																
Heating capacity	kW	4,72	5,19	5,47	5,64	5,81	5,00	5,53	5,84	6,03	6,20	NA				
Water flow rate	l/s	0,23	0,25	0,26	0,27	0,28	0,24	0,27	0,28	0,29	0,30					
	l/h	820	900	950	980	1010	870	960	1020	1050	1080					
Water pressure drop	kPa	36,5	43	47,1	49,7	52,2	45	53,4	58,7	62	65,1					
Water volume	l	1,4					1,8									
<b>Cooling mode, four pipes<sup>(1)</sup></b>																
Total cooling capacity	kW	NA					3,59	3,93	4,13	4,25	4,36	3,99	4,40	4,66	4,82	4,97
Sensible cooling capacity	kW						2,96	3,25	3,43	3,55	3,65	3,23	3,58	3,81	3,95	4,08
Water flow	l/s						0,18	0,19	0,20	0,21	0,21	0,19	0,22	0,23	0,24	0,24
	l/h						640	690	730	750	770	700	780	820	850	880
Water pressure drop	kPa						30,6	35,5	38,7	40,5	42,5	32,8	38,9	43	45,6	47,9
Water volume	l						1,1					1,4				
<b>Heating mode, four pipes<sup>(3)</sup></b>																
Heating capacity	kW	NA					3,89	4,21	4,41	4,52	4,64	4,67	5,10	5,34	5,48	5,61
Water flow	l/s						0,09	0,10	0,11	0,11	0,11	0,11	0,13	0,13	0,13	0,14
	l/h						340	370	390	400	410	410	450	470	480	490
Water pressure drop	kPa						8,7	9,9	10,6	11,1	11,5	10,8	12,4	13,4	14	14,5
Water volume	l											0,5				
<b>Electric heater</b>																
		230V ±10% - 1ph - 50Hz					230V ±10% - 1ph - 50Hz					230V ±10% - 1ph - 50Hz				
Maximum capacity	W	2000					2000					2000				
Current input	A	9,1					9,1					9,1				
<b>Sound levels</b>																
Sound power level (return and radiated)	dB(A)	55	56	57	58	58	55	56	57	58	58	55	56	57	58	58
Sound power level (supply)	dB(A)	55	57	59	60	61	55	57	59	60	61	55	57	59	60	61
<b>Electrical data, motor</b>																
Power input	W	105	113	117	124	134	105	113	117	124	134	105	113	117	124	134
Current input	A	0,59	0,64	0,67	0,71	0,76	0,59	0,64	0,67	0,71	0,76	0,59	0,64	0,67	0,71	0,76
FCEER [energy class] - 2 pipes		34 [D]					42 [C]									
FCCOP [energy class]		45 [C]					48 [C]									
FCEER [energy class] - 4 pipes							34 [D]					38 [D]				
FCCOP [energy class]							37 [D]					45 [C]				

Fan speed: L = Low, M = Medium, H = High



Eurovent certified values

- (1) Eurovent conditions: inlet air temperature = 27 °C db/47 % RH – water inlet temperature = 7 °C, water temperature difference = 5 K.
- (2) Eurovent conditions: inlet air temperature = 20 °C, water inlet temperature = 50 °C, water flow identical to cooling mode.
- (3) Eurovent conditions: inlet air temperature = 20 °C, water inlet temperature = 70 °C, water temperature difference = 10K.

## 7 - 42NH AND 42NL PERFORMANCE DATA

42NH	529					539					549					
Fan speed	2V	5V	6V	8V	10V	2V	5V	6V	8V	10V	2V	5V	6V	8V	10V	
(Eurovent certification speeds)	(L)	(M)	(H)		Max	(L)	(M)	(H)		Max	(L)	(M)	(H)		Max	
Air flow	l/s	85	213	244	307	347	85	213	244	307	347	85	213	244	307	347
	m <sup>3</sup> /h	306	765	878	1105	1249	306	765	878	1105	1249	306	765	878	1105	1249
Available static pressure	Pa	8	50	66	104	133	8	50	66	104	133	8	50	66	104	133
<b>Cooling mode, two pipes<sup>(1)</sup></b>																
Total cooling capacity	kW	1,70	3,57	3,93	4,54	4,86	1,77	4,37	4,88	5,72	6,13	NA				
Sensible cooling capacity	kW	1,37	2,98	3,31	3,89	4,19	1,41	3,46	3,88	4,63	5,01					
Water flow	l/s	0,08	0,17	0,19	0,22	0,24	0,08	0,21	0,24	0,28	0,30					
	l/h	290	620	690	800	870	300	760	850	1010	1090					
Water pressure drop	kPa	7,2	28,4	33	42,9	49,1	7,2	38,1	46,5	61,6	70,3					
Water volume	l	1,4					1,8									
<b>Heating mode, two pipes<sup>(2)</sup></b>																
Heating capacity	kW	1,98	4,71	5,26	6,20	6,68	1,80	4,99	5,61	6,61	7,07	NA				
Water flow	l/s	0,09	0,23	0,26	0,30	0,32	0,09	0,24	0,27	0,32	0,34					
	l/h	340	820	920	1080	1160	310	870	980	1150	1230					
Water pressure drop	kPa	8,8	36,4	44	58,3	66,4	8,4	44,8	54,8	72,6	81,6					
Water volume	l	1,4					1,8									
<b>Cooling mode, four pipes<sup>(1)</sup></b>																
Total cooling capacity	kW	NA					1,65	3,64	4,01	4,64	4,97	1,73	4,03	4,51	5,35	6,02
Sensible cooling capacity	kW						1,34	3,00	3,33	3,92	4,23	1,39	3,28	3,68	4,42	5,04
Water flow	l/s						0,08	0,18	0,19	0,23	0,25	0,08	0,19	0,22	0,26	0,29
	l/h						280	630	700	820	890	300	700	790	940	1030
Water pressure drop	kPa						7,2	30,5	36,3	47,3	54	6,8	32,8	40	54,3	62
Water volume	l						1,1					1,4				
<b>Heating mode, four pipes<sup>(3)</sup></b>																
Heating capacity	kW	NA					1,87	3,88	4,26	4,90	5,23	1,88	4,66	5,16	5,91	7,44
Water flow	l/s						0,04	0,09	0,10	0,12	0,13	0,04	0,11	0,13	0,14	0,18
	l/h						160	340	370	430	460	160	410	450	520	650
Water pressure drop	kPa						3,2	8,7	10,1	12,6	14	2,9	10,8	12,7	15,8	22
Water volume	l											0,5				
<b>Electric heater</b>																
		230V ±10% - 1ph - 50Hz					230V ±10% - 1ph - 50Hz					230V ±10% - 1ph - 50Hz				
Maximum capacity	W	2000					2000					2000				
Current input	A	9,1					9,1					9,1				
<b>Sound levels</b>																
Sound power level (return and radiated)	dB(A)	35	53	57	63	66	35	53	57	63	66	35	53	57	63	66
Sound power level (supply)	dB(A)	36	57	61	66	70	36	57	61	66	70	36	57	61	66	70
<b>Electrical data, motor</b>																
Power input	W	9	52	78	146	212	9	52	78	146	212	9	52	78	146	212
Current input	A	0,12	0,67	0,95	1,58	1,88	0,12	0,67	0,95	1,58	1,88	0,12	0,67	0,95	1,58	1,88
FCEER [energy class] - 2 pipes		94 [A]					107 [A]									
FCCOP [energy class]		122 [A]					120 [A]									
FCEER [energy class] - 4 pipes							93 [A]					101 [A]				
FCCOP [energy class]							107 [A]					118 [A]				

Fan speed: L = Low, M = Medium, H = High



Eurovent certified values

- (1) Eurovent conditions: inlet air temperature = 27 °C db/47 % RH – water inlet temperature = 7 °C, water temperature difference = 5 K.  
 (2) Eurovent conditions: inlet air temperature = 20 °C, water inlet temperature = 50 °C, water flow identical to cooling mode.  
 (3) Eurovent conditions: inlet air temperature = 20 °C, water inlet temperature = 70 °C, water temperature difference = 10K.

## 7 - 42NH AND 42NL PERFORMANCE DATA

### 7.7 - Physical and electrical data at Eurovent conditions - 42NH - Sizes 6 and 7

#### With G3 filter - without plenum

42NH		635					645				
<b>Fan speed</b>		<b>R5</b>	<b>R4</b>	<b>R3</b>	<b>R2</b>	<b>R1</b>	<b>R5</b>	<b>R4</b>	<b>R3</b>	<b>R2</b>	<b>R1</b>
(Eurovent certification speeds)			(L)	(M)	(H)	Max		(L)	(M)	(H)	Max
Air flow	l/s	200	298	397	460	499	200	298	397	460	499
	m <sup>3</sup> /h	720	1072	1428	1657	1796	720	1072	1428	1657	1796
Available static pressure	Pa	13	28	50	67	79	13	28	50	67	79
<b>Cooling mode, two pipes<sup>(1)</sup></b>											
Total cooling capacity	kW	4,03	5,81	7,31	8,08	8,47	4,57	6,80	8,62	9,52	9,97
Sensible cooling capacity	kW	3,17	4,62	5,94	6,67	7,06	3,44	5,14	6,65	7,49	7,92
Water flow	l/s	0,20	0,29	0,36	0,40	0,42	0,23	0,33	0,42	0,47	0,49
	l/h	720	1030	1290	1430	1500	820	1200	1520	1680	1760
Water pressure drop	kPa	12,3	24	35	41,3	45,1	12,1	25	38,6	45,1	49
Water volume	l	1,5					2				
<b>Heating mode, two pipes<sup>(2)</sup></b>											
Heating capacity	kW	5,21	7,59	9,76	11,00	11,67	5,56	8,21	10,59	11,92	12,64
Water flow	l/s	0,25	0,37	0,47	0,53	0,56	0,27	0,40	0,51	0,58	0,61
	l/h	910	1320	1700	1910	2030	970	1430	1840	2070	2200
Water pressure drop	kPa	15,9	29,7	45,6	56	62,1	14,8	28,1	43,4	53,1	58,8
Water volume	l	1,5					2,0				
<b>Cooling mode, four pipes<sup>(1)</sup></b>											
Total cooling capacity	kW	NA					3,80	5,38	6,63	7,22	7,52
Sensible cooling capacity	kW	NA					3,05	4,40	5,56	6,18	6,50
Water flow	l/s	NA					0,19	0,27	0,33	0,36	0,37
	l/h	NA					680	960	1180	1280	1340
Water pressure drop	kPa	NA					11,1	20,9	29,9	34,4	37,1
Water volume	l	NA					1,3				
<b>Heating mode, four pipes<sup>(3)</sup></b>											
Heating capacity	kW	NA					4,92	6,79	8,05	8,57	8,82
Water flow	l/s	NA					0,12	0,17	0,20	0,21	0,21
	l/h	NA					430	600	710	750	770
Water pressure drop	kPa	NA					6,6	10,8	14,2	15,7	16,5
Water volume	l	NA					0,7				
<b>Electric heater</b>		230V ±10% - 1ph - 50Hz					230V ±10% - 1ph - 50Hz				
Maximum capacity	W	3200					3200				
Current input	A	14,6					14,6				
<b>Sound levels</b>											
Sound power level (return and radiated)	dB(A)	50	56	58	61	62	50	56	58	61	62
Sound power level (supply)	dB(A)	50	59	62	65	66	50	59	62	65	66
<b>Electrical data, motor</b>											
Power input	W	185	217	225	242	286	185	217	225	242	286
Current input	A	0,96	1,11	1,28	1,38	1,55	0,96	1,11	1,28	1,38	1,55
FCEER [energy class] - 2 pipes		29 [D]					34 [D]				
FCCOP [energy class]		38 [D]					41 [C]				
FCEER [energy class] - 4 pipes							26 [D]				
FCCOP [energy class]							33 [D]				

Fan speed: L = Low, M = Medium, H = High



Eurovent certified values

- (1) Eurovent conditions: inlet air temperature = 27 °C db/47 % RH – water inlet temperature = 7 °C, water temperature difference = 5 K.  
 (2) Eurovent conditions: inlet air temperature = 20 °C, water inlet temperature = 50 °C, water flow identical to cooling mode.  
 (3) Eurovent conditions: inlet air temperature = 20 °C, water inlet temperature = 70 °C, water temperature difference = 10K.



## 7 - 42NH AND 42NL PERFORMANCE DATA

42NH	639				649				
<b>Fan speed</b>	<b>2V</b>	<b>6V</b>	<b>7V</b>	<b>10V</b>	<b>2V</b>	<b>7V</b>	<b>8V</b>	<b>10V</b>	
(Eurovent certification speeds)	(L)	(M)	(H)	Max	(L)	(M)	(H)	Max	
Air flow	l/s	102	269	303	389	90	327	364	426
	m <sup>3</sup> /h	368	967	1089	1400	323	1176	1310	1532
Available static pressure	Pa	7	50	63	105	4	50	62	85
<b>Cooling mode, two pipes<sup>(1)</sup></b>									
Total cooling capacity	kW	1,76	5,44	5,99	7,21	1,87	7,49	8,14	9,04
Sensible cooling capacity	kW	1,40	4,34	4,80	5,85	1,51	5,71	6,25	7,04
Water flow	l/s	0,08	0,26	0,29	0,36	0,09	0,36	0,39	0,44
	l/h	300	950	1050	1280	320	1300	1420	1590
Water pressure drop	kPa	3,5	20,3	24,6	34,2	3,7	29,1	34,4	41,3
Water volume	l	1,5			2				
<b>Heating mode, two pipes<sup>(2)</sup></b>									
Heating capacity	kW	2,19	6,90	7,70	9,60	2,33	8,94	9,84	11,21
Water flow	l/s	0,11	0,33	0,37	0,46	0,11	0,43	0,48	0,54
	l/h	380	1200	1340	1670	410	1550	1710	1950
Water pressure drop	kPa	4,1	25,3	30,4	44,4	3,7	32,5	38,3	47,8
Water volume	l	1,5			2				
<b>Cooling mode, four pipes<sup>(1)</sup></b>									
Total cooling capacity	kW	NA				1,83	5,90	6,33	6,91
Sensible cooling capacity	kW	NA				1,48	4,87	5,27	5,85
Water flow	l/s	NA				0,09	0,29	0,31	0,34
	l/h	NA				310	1030	1110	1230
Water pressure drop	kPa	NA				3,6	23,9	27,7	32
Water volume	l	NA				1,3			
<b>Heating mode, four pipes<sup>(3)</sup></b>									
Heating capacity	kW	NA				2,17	7,22	7,70	8,30
Water flow	l/s	NA				0,05	0,18	0,19	0,20
	l/h	NA				190	630	670	730
Water pressure drop	kPa	NA				2,3	11,9	13,2	14,9
Water volume	l	NA				0,7			
<b>Electric heater</b>									
		230V ±10% - 1ph - 50Hz				230V ±10% - 1ph - 50Hz			
Maximum capacity	W	3200				3200			
Current input	A	14,6				14,6			
<b>Sound levels</b>									
Sound power level (return and radiated)	dB(A)	38	58	61	67	38	61	64	67
Sound power level (supply)	dB(A)	46	60	63	69	46	63	66	69
<b>Electrical data, motor</b>									
Power input	W	8	76	106	222	9	111	153	233
Current input	A	0,09	0,71	1,02	2,01	0,09	0,71	1,02	2,01
FCEER [energy class] - 2 pipes		92 [A]				83 [B]			
FCCOP [energy class]		122 [A]				105 [A]			
FCEER [energy class] - 4 pipes						70 [B]			
FCCOP [energy class]						89 [A]			

Fan speed: L = Low, M = Medium, H = High



Eurovent certified values

- (1) Eurovent conditions: inlet air temperature = 27 °C db/47 % RH – water inlet temperature = 7 °C, water temperature difference = 5 K.  
 (2) Eurovent conditions: inlet air temperature = 20 °C, water inlet temperature = 50 °C, water flow identical to cooling mode.  
 (3) Eurovent conditions: inlet air temperature = 20 °C, water inlet temperature = 70 °C, water temperature difference = 10K.

## 7 - 42NH AND 42NL PERFORMANCE DATA

42NH	735					745					
<b>Fan speed</b>	<b>R5</b>	<b>R4</b>	<b>R3</b>	<b>R2</b>	<b>R1</b>	<b>R5</b>	<b>R4</b>	<b>R3</b>	<b>R2</b>	<b>R1</b>	
(Eurovent certification speeds)			(L)	(M)	(H)			(L)	(M)	(H)	
Air flow	l/s	148	218	374	533	600	148	218	374	533	600
	m <sup>3</sup> /h	534	785	1346	1918	2161	534	785	1346	1918	2161
Available static pressure	Pa	4	8	25	50	63	4	8	25	50	63
<b>Cooling mode, two pipes<sup>(1)</sup></b>											
Total cooling capacity	kW	3,19	4,66	7,62	9,97	10,76	3,43	5,09	8,52	11,32	12,25
Sensible cooling capacity	kW	2,42	3,55	5,92	7,98	8,72	2,55	3,77	6,41	8,75	9,60
Water flow	l/s	0,16	0,23	0,38	0,49	0,53	0,17	0,25	0,42	0,56	0,60
	l/h	580	840	1360	1770	1910	620	910	1510	2000	2160
Water pressure drop	kPa	9,1	18,1	42,5	66,4	75,8	7,9	16	41,8	66,2	75,9
Water volume	l	2					2,6				
<b>Heating mode, two pipes<sup>(2)</sup></b>											
Heating capacity	kW	3,81	5,46	9,03	12,49	13,86	3,85	5,62	9,55	13,38	14,88
Water flow	l/s	0,18	0,26	0,44	0,60	0,67	0,19	0,27	0,46	0,65	0,72
	l/h	660	950	1570	2170	2410	670	980	1660	2330	2590
Water pressure drop	kPa	10,7	19,1	44,7	78,2	93,7	9	16,3	39,5	70,5	84,8
Water volume	l	2					2,6				
<b>Cooling mode, four pipes<sup>(1)</sup></b>											
Total cooling capacity	kW	2,80	3,95	6,29	8,28	8,99	3,33	4,94	8,11	10,46	11,18
Sensible cooling capacity	kW	2,22	3,17	5,16	6,96	7,61	2,50	3,69	6,18	8,25	8,96
Water flow	l/s	0,14	0,20	0,31	0,41	0,44	0,17	0,25	0,40	0,51	0,55
	l/h	510	720	1130	1480	1600	600	890	1440	1850	1980
Water pressure drop	kPa	8,9	16,5	36	56,8	65,6	9,9	20,3	47,6	72,9	81,9
Water volume	l	1,3					1,7				
<b>Heating mode, four pipes<sup>(3)</sup></b>											
Heating capacity	kW	3,64	5,20	8,43	11,16	12,13	4,14	6,31	10,54	13,74	14,80
Water flow	l/s	0,09	0,13	0,21	0,27	0,29	0,10	0,15	0,26	0,33	0,36
	l/h	320	460	740	980	1060	360	550	920	1200	1300
Water pressure drop	kPa	5,1	8,6	18,5	29,7	34,3	5,4	10,2	23,6	36,9	41,9
Water volume	l	0,7					0,9				
<b>Electric heater</b>											
		230V ±10% - 1ph - 50Hz					230V ±10% - 1ph - 50Hz				
Maximum capacity	W	3200					3200				
Current input	A	14,6					14,6				
<b>Sound levels</b>											
Sound power level (return and radiated)	dB(A)	41	48	57	63	64	41	48	57	63	64
Sound power level (supply)	dB(A)	42	48	58	66	68	42	48	58	66	68
<b>Electrical data, motor</b>											
Power input	W	174	227	282	316	356	174	227	282	316	356
Current input	A	0,84	1,08	1,40	1,74	1,86	0,84	1,08	1,40	1,74	1,86
FCEER [energy class] - 2 pipes		29 [D]					32 [D]				
FCCOP [energy class]		34 [D]					37 [D]				
FCEER [energy class] - 4 pipes		24 [E]					30 [D]				
FCCOP [energy class]		32 [D]					39 [D]				

Fan speed: L = Low, M = Medium, H = High



Eurovent certified values

- (1) Eurovent conditions: inlet air temperature = 27 °C db/47 % RH – water inlet temperature = 7 °C, water temperature difference = 5 K.  
 (2) Eurovent conditions: inlet air temperature = 20 °C, water inlet temperature = 50 °C, water flow identical to cooling mode.  
 (3) Eurovent conditions: inlet air temperature = 20 °C, water inlet temperature = 70 °C, water temperature difference = 10K.

## 7 - 42NH AND 42NL PERFORMANCE DATA

42NH	739				749				
	2V	7V	8V	10V	2V	7V	8V	10V	
<b>Fan speed</b>									
(Eurovent certification speeds)	(L)	(M)	(H)	Max	(L)	(M)	(H)	Max	
Air flow	124	441	477	529	124	441	477	529	
	l/s								
	m <sup>3</sup> /h	445	1586	1717	1906	445	1586	1717	
Available static pressure	Pa	4	50	59	72	4	50	59	
<b>Cooling mode, two pipes<sup>(1)</sup></b>									
Total cooling capacity	kW	2,79	8,84	9,34	10,00	2,97	9,94	10,56	
Sensible cooling capacity	kW	2,16	6,99	7,43	8,01	2,25	7,60	8,11	
Water flow	l/s	0,13	0,43	0,45	0,49	0,14	0,48	0,51	
	l/h	480	1540	1630	1760	510	1730	1840	
Water pressure drop	kPa	6,6	52,7	58,2	65,9	5,8	51,8	57,7	
Water volume	l	2			2,6				
<b>Heating mode, two pipes<sup>(2)</sup></b>									
Heating capacity	kW	3,22	10,51	11,31	12,42	3,22	11,19	12,07	
Water flow	l/s	0,16	0,51	0,55	0,60	0,16	0,54	0,58	
	l/h	560	1830	1970	2160	560	1950	2100	
Water pressure drop	kPa	8,3	58	65,8	77,4	6,6	51,8	59,1	
Water volume	l	2			2,6				
<b>Cooling mode, four pipes<sup>(1)</sup></b>									
Total cooling capacity	kW	2,51	7,33	7,75	8,31	2,89	9,36	9,86	
Sensible cooling capacity	kW	2,02	6,10	6,48	6,99	2,21	7,27	7,71	
Water flow	l/s	0,12	0,36	0,38	0,41	0,14	0,45	0,48	
	l/h	430	1280	1360	1470	500	1630	1720	
Water pressure drop	kPa	6,7	44,7	49,5	56,4	7,1	58,7	64,6	
Water volume	l	1,3			1,7				
<b>Heating mode, four pipes<sup>(3)</sup></b>									
Heating capacity	kW	3,07	9,65	10,28	11,11	3,36	12,02	12,75	
Water flow	l/s	0,08	0,24	0,25	0,27	0,08	0,29	0,31	
	l/h	270	850	900	970	290	1050	1120	
Water pressure drop	kPa	4	23,3	25,9	29,5	4,1	29,4	32,5	
Water volume	l	0,7			0,9				
<b>Electric heater</b>		230V ±10% - 1ph - 50Hz				230V ±10% - 1ph - 50Hz			
Maximum capacity	W	3000				3000			
Current input	A	13,7				13,7			
<b>Sound levels</b>									
Sound power level (return and radiated)	dB(A)	45	60	62	63	45	60	62	
Sound power level (supply)	dB(A)	44	61	63	65	44	61	63	
<b>Electrical data, motor</b>									
Power input	W	10	137	177	240	10	137	177	
Current input	A	0,11	1,11	1,38	1,85	0,11	1,11	1,38	
FCEER [energy class] - 2 pipes		87 [A]				96 [A]			
FCCOP [energy class]		109 [A]				113 [A]			
FCEER [energy class] - 4 pipes		75 [B]				92 [A]			
FCCOP [energy class]		101 [A]				120 [A]			

Fan speed: L = Low, M = Medium, H = High



Eurovent certified values

- (1) Eurovent conditions: inlet air temperature = 27 °C db/47 % RH – water inlet temperature = 7 °C, water temperature difference = 5 K.  
 (2) Eurovent conditions: inlet air temperature = 20 °C, water inlet temperature = 50 °C, water flow identical to cooling mode.  
 (3) Eurovent conditions: inlet air temperature = 20 °C, water inlet temperature = 70 °C, water temperature difference = 10K.

## 7 - 42NH AND 42NL PERFORMANCE DATA

### 7.8 - Electrical data

#### 7.8.1 - 42NL

42NL 2-5 (AC multi-speed version)

Speed	I	P	Qv	Qv	ESP
	(A)	(W)	(l/s)	(m <sup>3</sup> /h)	G3 Filter (Pa)
R1	0,35	80	138	495	0
	0,35	80	136	490	3
	0,35	79	131	470	12
	0,35	79	125	450	19
	0,35	78	119	430	26
	0,35	77	114	410	33
	0,34	77	108	390	38
	0,34	76	103	370	44
	0,34	76	97	350	48
	0,34	75	92	330	53
	0,34	75	86	310	57
	0,34	75	81	290	60
R2	0,33	73	56	200	73
	0,28	65	125	450	0
	0,28	65	119	430	7
	0,28	64	114	410	14
	0,28	64	108	390	21
	0,27	63	103	370	27
	0,27	63	97	350	33
	0,27	62	92	330	38
	0,27	62	86	310	43
	0,27	61	81	290	48
	0,26	61	75	270	52
	0,26	60	69	250	56
0,26	59	64	230	60	
0,26	59	58	210	63	
0,26	58	53	190	67	
0,26	58	47	170	70	
R3	0,23	54	110	394	0
	0,23	53	103	370	10
	0,23	53	97	350	18
	0,23	52	92	330	25
	0,23	51	86	310	30
	0,23	51	81	290	35
	0,23	50	75	270	40
	0,22	50	69	250	44
	0,22	49	64	230	49
	0,22	49	58	210	53
	0,21	48	53	190	57
	0,21	48	47	170	62
0,21	48	42	150	68	
R4	0,20	45	96	345	0
	0,20	45	94	340	2
	0,20	45	89	320	9
	0,20	44	83	300	15
	0,19	44	78	280	21
	0,19	43	72	260	27
	0,19	43	67	240	32
	0,19	42	61	220	38
	0,18	42	56	200	43
	0,18	41	50	180	49
	0,18	41	44	160	55
	R5	0,14	31	69	247
0,14		31	68	245	1
0,14		31	65	235	4
0,13		31	56	200	13
0,13		31	50	180	18
0,13		31	47	170	21
0,13		31	44	160	24
0,13		30	42	150	27
0,13		30	39	140	30
0,13		30	36	130	33
0,13		29	33	120	36
0,13		29	31	110	39
R6	0,12	28	61	211	0
	0,12	27	50	180	6
	0,12	27	47	170	8
	0,12	27	44	160	11
	0,12	27	42	150	13
	0,12	27	39	140	15
	0,12	27	36	130	18
	0,12	27	28	100	26

**Key**

- I Current drawn by the fan motor
- P Power input to the fan motor

42NL 2-9 (EC brushless motor)

Speed	I	P	Qv	Qv	ESP
	(A)	(W)	(l/s)	(m <sup>3</sup> /h)	G3 Filter (Pa)
10V	0,14	13	103	370	0
	0,13	13	97	350	4
	0,13	13	90	325	9
	0,13	13	94	340	6
	0,13	13	89	320	10
	0,13	12	83	300	14
	0,12	12	78	280	18
	0,11	10	56	200	30
	0,09	8	28	100	42
	9V	0,12	12	97	350
0,12		12	90	325	5
0,12		11	83	300	10
0,12		11	76	275	15
0,12		10	69	250	19
0,11		10	63	225	23
0,11		9	56	200	26
8V	0,10	9	49	175	29
	0,09	8	28	100	37
	0,11	10	89	320	0
	0,11	10	83	300	4
	0,11	9	75	270	10
	0,10	9	67	240	14
	0,10	8	58	210	19
7V	0,09	8	50	180	22
	0,09	7	42	150	26
	0,09	7	33	120	30
	0,08	7	25	90	33
	0,10	9	81	292	0
	0,10	8	76	275	3
	0,09	8	69	250	8
6V	0,09	8	64	230	11
	0,09	7	58	210	14
	0,08	7	42	150	21
	0,08	6	28	100	26
	0,07	6	21	75	28
	0,08	7	74	261	0
	0,07	7	69	250	2
5V	0,07	6	64	230	4
	0,07	6	58	210	7
	0,07	6	53	190	10
	0,07	6	47	170	13
	0,07	5	42	150	15
	0,07	5	31	110	20
	0,07	5	21	75	23
4V	0,06	5	65	235	0
	0,06	5	60	215	2
	0,06	5	56	200	4
	0,06	5	50	180	7
	0,06	5	44	160	9
	0,06	5	39	140	11
	0,06	4	33	120	13
3V	0,06	4	28	100	15
	0,05	4	17	60	18
	0,06	5	58	210	0
	0,06	4	56	200	1
	0,06	4	49	175	4
	0,06	4	42	150	7
	0,06	4	35	125	10
2V	0,06	4	28	100	12
	0,06	4	21	75	14
	0,05	3	14	50	16
	0,06	4	51	182	0
	0,06	3	47	170	1
	0,06	3	42	150	3
	0,05	3	28	100	8
1V	0,05	3	14	50	11
	0,05	3	43	155	0
	0,05	3	38	135	2
	0,05	3	32	115	3
	0,05	3	26	95	5
0,04	2	11	40	8	

- Qv Air flow
- ESP Available external static pressure
- R Fixed speed

7 - 42NH AND 42NL PERFORMANCE DATA

42NL 3-5 (AC multi-speed version)

Speed	I	P	Qv	Qv	ESP
	(A)	(W)	(l/s)	(m³/h)	G3 Filter (Pa)
R1	0,44	99	168	605	0
	0,44	99	167	600	3
	0,43	98	161	580	11
	0,43	96	156	560	18
	0,42	95	150	540	25
	0,41	94	144	520	31
	0,41	93	139	500	37
	0,41	92	133	480	43
	0,40	91	128	460	48
	0,40	90	122	440	53
	0,39	90	117	420	58
	0,39	89	111	400	62
0,39	89	106	380	66	
0,39	88	100	360	70	
R2	0,37	86	154	555	0
	0,37	85	153	550	2
	0,36	84	147	530	11
	0,35	82	142	510	20
	0,35	81	136	490	27
	0,34	80	131	470	34
	0,34	79	125	450	40
	0,34	78	119	430	46
	0,33	77	114	410	51
	0,33	77	108	390	56
	0,33	76	103	370	61
	0,32	75	97	350	65
0,32	75	92	330	69	
0,32	75	90	325	70	
R3	0,32	74	143	515	0
	0,31	73	139	500	8
	0,31	72	133	480	16
	0,30	71	128	460	24
	0,30	70	122	440	31
	0,29	69	117	420	37
	0,29	68	111	400	43
	0,29	67	106	380	48
	0,28	66	100	360	53
	0,28	65	94	340	57
	0,28	64	89	320	62
	0,27	64	83	300	66
0,27	63	78	280	69	
R4	0,27	62	124	445	0
	0,27	62	122	440	4
	0,26	60	117	420	13
	0,26	59	111	400	22
	0,25	57	106	380	30
	0,25	57	100	360	37
	0,24	56	94	340	43
	0,24	55	89	320	48
	0,24	55	83	300	54
	0,24	54	78	280	58
	0,24	54	72	260	63
	0,23	54	67	240	67
R5	0,20	45	94	340	0
	0,19	44	89	320	7
	0,19	43	83	300	15
	0,18	42	78	280	22
	0,18	42	72	260	29
	0,18	41	67	240	36
	0,18	41	61	220	42
0,18	41	56	200	48	
R6	0,16	38	83	300	0
	0,16	37	78	280	7
	0,16	37	72	260	14
	0,16	37	67	240	20
	0,16	37	61	220	26
	0,16	36	56	200	32
0,16	36	50	180	38	
0,15	36	44	160	44	

**Key**  
**I** Current drawn by the fan motor    **R** Fixed speed  
**P** Power input to the fan motor  
**Qv** Air flow rate  
**ESP** Available external static pressure

42NL 3-9 (EC brushless motor)

Speed	I	P	Qv	Qv	ESP	
	(A)	(W)	(l/s)	(m³/h)	G3 Filter (Pa)	
10V	0,39	49	168	605	0	
	0,39	49	167	600	2	
	0,38	48	161	580	8	
	0,37	47	156	560	14	
	0,37	46	150	540	20	
	0,36	45	144	520	27	
	0,35	44	139	500	33	
	0,34	43	133	480	39	
	0,31	39	111	400	64	
	9V	0,35	41	153	550	0
		0,34	40	147	530	9
		0,33	39	142	510	17
0,31		38	136	490	24	
0,30		37	131	470	31	
0,30		37	125	450	37	
8V	0,29	36	119	430	43	
	0,28	35	114	410	49	
	0,27	33	103	370	59	
	0,30	34	144	517	0	
	0,30	34	142	510	3	
	0,28	33	136	490	11	
7V	0,27	32	131	470	19	
	0,26	31	125	450	25	
	0,25	31	119	430	31	
	0,24	30	114	410	37	
	0,23	27	97	350	51	
	0,22	26	89	320	56	
	6V	0,27	33	133	480	0
		0,26	32	128	460	6
		0,25	31	122	440	13
		0,24	30	117	420	19
		0,24	29	111	400	24
		0,23	29	106	380	29
0,23		28	100	360	33	
0,22		25	83	300	44	
0,20		23	69	250	53	
5V		0,17	20	119	430	0
		0,16	19	111	400	8
		0,16	18	106	380	13
	0,16	18	100	360	17	
	0,15	17	94	340	21	
	0,15	16	83	300	28	
	0,14	15	69	250	37	
	0,13	14	56	200	46	
	0,12	14	53	190	48	
	4V	0,14	15	103	370	0
		0,13	14	97	350	5
		0,13	14	92	330	10
0,13		13	86	310	14	
0,12		13	81	290	18	
0,12		12	75	270	22	
0,12		12	69	250	25	
0,11		11	56	200	33	
0,09		10	42	150	42	
3V		0,10	10	89	320	0
		0,10	9	83	300	4
		0,10	9	78	280	9
	0,09	9	72	260	12	
	0,09	8	67	240	15	
	0,09	8	61	220	18	
	0,09	8	56	200	21	
	0,09	7	42	150	26	
	0,08	7	28	100	32	
	2V	0,08	7	69	250	0
		0,08	6	56	200	10
		0,07	6	42	150	16
0,07		5	28	100	21	
0,05		4	14	50	26	
0,06		4	54	195	0	
0,06		4	42	150	6	
0,06		4	28	100	10	
0,05		3	14	50	13	
0,05		3	7	25	15	



## 7 - 42NH AND 42NL PERFORMANCE DATA

42NL 4-5 (AC multi-speed version)

Speed	I	P	Qv	Qv	ESP
	(A)	(W)	(l/s)	(m <sup>3</sup> /h)	G3 Filter (Pa)
R1	0,69	157	299	1075	0
	0,69	156	292	1050	6
	0,68	155	278	1000	17
	0,68	154	264	950	26
	0,67	152	250	900	35
	0,67	150	236	850	42
	0,66	149	222	800	50
	0,65	147	208	750	56
	0,65	145	194	700	62
	0,64	144	181	650	68
	0,63	142	167	600	73
	0,63	141	153	550	78
R2	0,57	129	267	960	0
	0,57	129	264	950	3
	0,56	128	257	925	10
	0,56	127	250	900	16
	0,55	126	242	870	23
	0,55	125	233	840	29
	0,54	123	225	810	35
	0,54	122	217	780	40
	0,53	121	208	750	45
	0,52	118	181	650	59
	0,51	116	167	600	65
	0,50	114	153	550	70
R3	0,49	113	233	840	0
	0,49	111	228	820	7
	0,48	110	222	800	14
	0,48	109	217	780	20
	0,47	107	211	760	26
	0,47	106	206	740	31
	0,46	105	200	720	35
	0,46	104	194	700	39
	0,46	103	189	680	43
	0,45	103	183	660	46
	0,45	102	178	640	49
	0,44	99	153	550	60
R4	0,43	98	208	750	0
	0,42	96	201	725	9
	0,41	94	194	700	17
	0,40	92	188	675	24
	0,40	91	181	650	30
	0,39	89	174	625	35
	0,39	89	167	600	40
	0,38	88	160	575	44
	0,38	87	153	550	48
	0,38	87	146	525	51
	0,38	86	139	500	55
	0,37	86	132	475	58
R5	0,30	68	149	535	0
	0,30	68	147	530	3
	0,29	66	139	500	14
	0,29	65	133	480	20
	0,28	65	128	460	24
	0,28	64	122	440	28
	0,28	64	119	430	30
	0,28	64	117	420	31
	0,28	64	114	410	33
	0,28	64	111	400	35
	0,28	64	108	390	36
	0,28	63	106	380	37
R6	0,25	57	129	465	0
	0,25	57	125	450	5
	0,25	56	119	430	11
	0,25	56	114	410	17
	0,24	56	108	390	21
	0,24	55	103	370	25
	0,24	55	97	350	28
	0,24	55	92	330	31
	0,24	55	86	310	33

**Key**  
**I** Current drawn by the fan motor  
**P** Power input to the fan motor

42NL 4-9 (EC brushless motor)

Speed	I	P	Qv	Qv	ESP	
	(A)	(W)	(l/s)	(m <sup>3</sup> /h)	G3 Filter (Pa)	
10V	0,80	99	226	815	0	
	0,79	99	222	800	7	
	0,79	99	215	775	19	
	0,79	99	208	750	31	
	0,78	98	201	725	43	
	0,77	97	194	700	54	
	0,76	95	188	675	64	
	0,74	93	181	650	74	
	0,73	91	174	625	83	
	0,75	91	217	780	0	
	0,72	89	208	750	14	
	0,70	87	201	725	26	
9V	0,69	85	194	700	36	
	0,67	83	188	675	46	
	0,66	81	181	650	56	
	0,64	79	174	625	65	
	0,63	77	167	600	73	
	0,61	75	160	575	81	
	0,65	78	207	745	0	
	0,63	76	201	725	8	
	0,60	73	194	700	19	
	0,58	71	188	675	29	
	0,57	70	181	650	38	
	0,56	68	174	625	46	
8V	0,55	66	167	600	53	
	0,54	65	160	575	60	
	0,53	64	153	550	67	
	0,54	58	192	690	0	
	0,53	58	188	675	5	
	0,50	57	181	650	13	
	0,48	55	174	625	21	
	0,46	54	167	600	28	
	0,44	53	160	575	35	
	0,43	52	153	550	42	
	0,42	51	146	525	49	
	0,41	49	139	500	55	
7V	0,38	42	169	610	0	
	0,37	42	167	600	3	
	0,35	41	160	575	10	
	0,33	40	153	550	17	
	0,32	39	146	525	24	
	0,31	38	139	500	31	
	0,30	36	132	475	37	
	0,30	35	125	450	44	
	0,29	34	118	425	49	
	0,29	30	150	540	0	
	0,28	29	146	525	3	
	0,27	28	139	500	9	
6V	0,25	28	132	475	15	
	0,24	27	125	450	21	
	0,23	26	118	425	27	
	0,22	25	111	400	32	
	0,22	24	104	375	37	
	0,21	23	97	350	41	
	0,18	18	124	445	0	
	0,17	18	118	425	4	
	0,16	17	111	400	8	
	0,15	17	104	375	13	
	0,14	16	97	350	17	
	0,14	15	90	325	21	
5V	0,13	15	83	300	25	
	0,13	14	76	275	28	
	0,13	13	69	250	32	
	0,12	11	97	350	0	
	0,11	10	83	300	8	
	0,10	9	69	250	15	
	0,10	9	56	200	21	
	0,09	8	42	150	26	
	4V	0,07	6	67	240	0
		0,07	5	56	200	4
		0,07	5	42	150	9
		0,06	4	28	100	12
0,06		4	14	50	15	

**Qv** Air flow  
**ESP** Available external static pressure  
**R** Fixed speed



7 - 42NH AND 42NL PERFORMANCE DATA

42NL 5-5 (AC multi-speed version)

Speed	I	P	Qv	Qv	ESP
	(A)	(W)	(l/s)	(m³/h)	G3 Filter (Pa)
R1	0,74	170	358	1290	0
	0,74	169	354	1275	2
	0,73	168	347	1250	6
	0,73	167	340	1225	10
	0,73	166	333	1200	14
	0,72	164	319	1150	21
	0,71	162	306	1100	28
	0,70	160	292	1050	35
	0,69	158	278	1000	41
	0,69	156	264	950	48
	0,68	155	250	900	54
	0,66	150	208	750	71
R2	0,60	137	313	1125	0
	0,60	136	306	1100	5
	0,59	135	299	1075	9
	0,59	134	292	1050	13
	0,58	132	278	1000	21
	0,57	129	264	950	29
	0,56	128	250	900	37
	0,55	126	236	850	44
	0,54	124	222	800	51
	0,54	122	208	750	58
	0,53	121	194	700	64
	0,52	119	181	650	70
R3	0,52	118	275	990	0
	0,51	116	264	950	8
	0,50	115	257	925	13
	0,50	113	250	900	18
	0,49	112	243	875	23
	0,49	111	236	850	28
	0,48	110	229	825	32
	0,48	109	222	800	37
	0,47	108	215	775	41
	0,47	107	208	750	45
	0,46	106	194	700	53
	0,45	103	167	600	66
R4	0,43	99	233	840	0
	0,43	97	222	800	10
	0,42	95	215	775	15
	0,42	94	208	750	21
	0,41	94	201	725	26
	0,41	93	194	700	31
	0,40	92	188	675	35
	0,40	91	181	650	39
	0,40	90	174	625	43
	0,40	90	167	600	47
	0,39	89	160	575	51
	0,39	89	153	550	54
R5	0,30	67	169	610	0
	0,30	67	167	600	2
	0,30	67	160	575	8
	0,29	66	153	550	13
	0,29	66	146	525	17
	0,29	66	139	500	22
	0,29	65	132	475	26
	0,29	65	125	450	30
	0,28	64	118	425	34
	0,28	64	111	400	37
	0,28	64	104	375	41
	0,28	63	97	350	45
R6	0,26	58	149	535	0
	0,25	58	139	500	8
	0,25	57	132	475	12
	0,25	57	125	450	16
	0,25	57	118	425	20
	0,25	57	111	400	24
	0,25	56	104	375	27
	0,25	56	97	350	31
0,25	56	90	325	35	

42NL 5-9 (EC brushless motor)

Speed	I	P	Qv	Qv	ESP	
	(A)	(W)	(l/s)	(m³/h)	G3 Filter (Pa)	
10V	0,39	58	254	915	0	
	0,39	57	250	900	3	
	0,37	55	236	850	11	
	0,36	54	222	800	18	
	0,35	52	208	750	26	
	0,34	50	194	700	33	
	0,33	49	181	650	41	
	0,32	47	167	600	48	
	0,29	44	139	500	62	
	0,34	51	243	875	0	
	0,34	50	236	850	4	
	0,32	48	222	800	11	
9V	0,31	46	208	750	18	
	0,30	44	194	700	25	
	0,28	42	181	650	32	
	0,27	41	167	600	38	
	0,26	39	153	550	45	
	0,24	36	125	450	58	
	0,28	43	229	825	0	
	0,28	42	222	800	4	
	0,26	39	208	750	10	
	0,25	37	194	700	16	
	0,24	36	181	650	23	
	0,23	34	167	600	29	
8V	0,22	33	153	550	35	
	0,22	32	139	500	42	
	0,20	30	111	400	54	
	0,22	33	208	750	0	
	0,21	31	194	700	6	
	0,20	29	181	650	13	
	0,19	28	167	600	19	
	0,19	27	153	550	25	
	0,18	26	139	500	31	
	0,17	25	125	450	36	
	0,17	24	111	400	42	
	0,15	22	83	300	52	
7V	0,17	24	186	670	0	
	0,16	23	181	650	3	
	0,16	22	167	600	9	
	0,15	21	153	550	14	
	0,14	20	139	500	20	
	0,14	19	125	450	24	
	0,13	18	111	400	29	
	0,13	17	97	350	34	
	0,11	15	69	250	42	
	0,13	18	169	610	0	
	0,13	17	167	600	1	
	0,12	16	153	550	5	
6V	0,12	16	139	500	10	
	0,11	15	125	450	14	
	0,11	14	111	400	19	
	0,10	13	97	350	23	
	0,10	13	83	300	27	
	0,09	11	56	200	35	
	0,09	11	139	500	0	
	0,08	10	125	450	4	
	0,08	10	111	400	8	
	0,08	9	97	350	12	
	0,07	9	83	300	16	
	0,07	8	69	250	20	
0,07	8	56	200	23		
0,06	7	42	150	26		
0,06	7	28	100	29		
5V	0,06	7	111	400	0	
	0,06	7	97	350	4	
	0,06	6	83	300	8	
	0,06	6	69	250	11	
	0,05	5	28	100	19	
	0,04	4	83	295	0	
	0,04	4	69	250	2	
	0,04	4	56	200	5	
	0,04	3	42	150	7	
	0,04	3	28	100	9	
	4V	0,04	3	111	400	0
		0,04	3	97	350	4
0,04		3	83	300	8	
0,04		3	69	250	11	
0,04		3	42	150	19	
0,04		3	28	100	29	
0,04		3	111	400	0	
0,04		3	97	350	4	
0,04		3	83	300	8	
0,04		3	69	250	11	
0,04		3	42	150	19	
0,04		3	28	100	29	
3V	0,04	3	111	400	0	
	0,04	3	97	350	4	
	0,04	3	83	300	8	
	0,04	3	69	250	11	
	0,04	3	42	150	19	
	0,04	3	28	100	29	
	0,04	3	111	400	0	
	0,04	3	97	350	4	
	0,04	3	83	300	8	
	0,04	3	69	250	11	
	0,04	3	42	150	19	
	0,04	3	28	100	29	
2V	0,04	3	111	400	0	
	0,04	3	97	350	4	
	0,04	3	83	300	8	
	0,04	3	69	250	11	
	0,04	3	42	150	19	
	0,04	3	28	100	29	
	0,04	3	111	400	0	
	0,04	3	97	350	4	
	0,04	3	83	300	8	
	0,04	3	69	250	11	
	0,04	3	42	150	19	
	0,04	3	28	100	29	

Key

- I Current drawn by the fan motor
- P Power input to the fan motor

- Qv Air flow
- ESP Available external static pressure
- R Fixed speed

PRESENTATION COOLING HEATING AIR TREATMENT CONTROLS

## 7 - 42NH AND 42NL PERFORMANCE DATA

### 7.8.2 - 42NH

42NH 2-5 (AC multi-speed version)

Speed	I	P	Qv	Qv	ESP	
	(A)	(W)	(l/s)	(m <sup>3</sup> /h)	G3 Filter (Pa)	
R1	0,24	54	143	515	0	
	0,24	54	142	510	3	
	0,24	53	136	490	12	
	0,24	53	131	470	20	
	0,23	52	125	450	28	
	0,23	51	119	430	35	
	0,23	51	114	410	41	
	0,22	50	108	390	47	
	0,22	49	103	370	52	
	0,21	48	97	350	57	
	0,21	47	92	330	61	
	0,19	43	69	250	74	
	0,18	41	56	200	80	
	0,17	39	42	150	85	
R2	0,23	50	99	355	0	
	0,22	48	93	335	12	
	0,22	46	88	315	23	
	0,21	45	82	295	32	
	0,20	43	76	275	41	
	0,20	42	71	255	49	
	0,19	40	65	235	56	
	0,18	39	60	215	62	
	0,18	38	57	205	65	
	0,18	37	54	195	68	
	0,18	36	51	185	70	
	0,17	36	49	175	72	
	0,17	35	46	165	74	
	0,17	35	43	155	76	
0,16	34	40	145	78		
0,16	33	38	135	80		
R3	0,22	48	79	285	0	
	0,22	47	74	265	12	
	0,21	45	68	245	24	
	0,20	44	65	235	29	
	0,20	42	63	225	35	
	0,20	41	60	215	39	
	0,19	40	57	205	44	
	0,19	39	54	195	49	
	0,18	38	51	185	53	
	0,18	37	49	175	56	
	0,18	36	46	165	60	
	0,17	35	43	155	63	
	0,17	34	40	145	67	
	0,16	33	38	135	69	
0,16	32	35	125	72		
R4	0,16	20	54	195	0	
	0,16	20	53	190	7	
	0,16	20	51	185	13	
	0,16	20	50	180	18	
	0,16	20	49	175	23	
	0,15	20	47	170	28	
	0,15	20	46	165	33	
	0,15	20	44	160	37	
	0,15	19	42	150	46	
	0,14	19	39	140	53	
	0,14	19	36	130	59	
	0,14	19	33	120	65	
	R5	0,13	13	35	125	0
		0,13	13	32	115	9
0,13		13	31	110	13	
0,13		13	29	105	17	
0,13		13	28	100	21	
0,13		13	26	95	25	
0,13		13	25	90	29	
0,12		13	24	85	33	
0,12		13	22	80	36	
0,12		13	21	75	40	
0,12		13	19	70	43	
0,12		13	18	65	46	
0,12		13	17	60	49	

42NH 229 & 239 (EC brushless motor)

Speed	I	P	Qv	Qv	ESP
	(A)	(W)	(l/s)	(m <sup>3</sup> /h)	G3 Filter (Pa)
10V	0,39	47	169	610	0
	0,38	47	167	600	2
	0,36	44	153	550	15
	0,35	42	139	500	29
	0,33	40	125	450	43
	0,31	37	111	400	57
	0,29	35	97	350	70
	0,26	32	69	250	90
	0,25	30	42	150	101
	9V	0,34	40	161	580
0,31		37	139	500	19
0,28		33	111	400	45
0,26		31	97	350	58
0,25		29	83	300	70
0,24		28	69	250	79
0,23		26	56	200	86
0,22		26	49	175	89
0,22		26	42	150	91
8V		0,28	32	147	530
	0,27	31	139	500	7
	0,26	30	133	480	12
	0,25	29	128	460	17
	0,25	29	122	440	22
	0,24	28	117	420	26
	0,21	24	83	300	53
	0,19	21	56	200	70
	0,18	20	42	150	75
	7V	0,22	24	133	480
0,21		24	125	450	8
0,20		23	111	400	20
0,19		21	97	350	30
0,18		20	83	300	40
0,16		18	69	250	48
0,15		17	56	200	56
0,14		15	42	150	62
0,13		15	35	125	66
6V		0,16	18	119	430
	0,16	18	111	400	6
	0,15	16	97	350	16
	0,14	15	83	300	25
	0,13	14	69	250	34
	0,12	13	56	200	41
	0,11	12	42	150	47
	0,11	11	35	125	50
	0,10	11	28	100	52
	5V	0,12	13	106	380
0,12		13	97	350	5
0,11		12	83	300	14
0,10		11	69	250	22
0,09		10	56	200	29
0,09		9	42	150	34
0,08		8	35	125	37
0,08		8	28	100	39
0,08		7	25	90	40
4V		0,09	10	90	325
	0,09	9	83	300	4
	0,09	9	78	280	7
	0,09	8	72	260	10
	0,09	8	67	240	13
	0,08	8	56	200	19
	0,08	7	42	150	24
	0,07	6	28	100	28
	0,06	6	21	75	29
	3V	0,07	6	72	260
0,07		5	56	200	7
0,07		5	39	140	14
0,06		4	28	100	17
0,06		4	22	80	19
2V		0,05	4	50	180
	0,05	3	44	160	4
	0,05	3	39	140	6
	0,05	3	28	100	9
	0,05	3	17	60	11

**Key**

I Current drawn by the fan motor  
 P Power input to the fan motor

Qv Air flow  
 ESP Available external static pressure

R Fixed speed



7 - 42NH AND 42NL PERFORMANCE DATA

42NH 279 (EC brushless motor)

Speed	I	P	Qv	Qv	ESP
	(A)	(W)	(l/s)	(m³/h)	G3 Filter (Pa)
10V	0,75	93	225	810	0
	0,75	93	222	800	3
	0,71	88	194	700	31
	0,69	85	181	650	46
	0,66	82	167	600	62
	0,63	78	153	550	77
	0,60	74	139	500	93
	0,57	71	125	450	109
	0,55	67	111	400	124
9V	0,65	81	213	767	0
	0,65	80	208	750	6
	0,63	78	194	700	20
	0,61	76	181	650	34
	0,59	73	167	600	49
	0,57	70	153	550	63
	0,54	66	139	500	78
	0,49	60	111	400	106
	0,46	56	97	350	120
8V	0,51	63	196	705	0
	0,51	63	194	700	1
	0,50	61	181	650	14
	0,48	59	167	600	27
	0,46	56	153	550	40
	0,44	53	139	500	54
	0,42	50	125	450	67
	0,37	45	97	350	93
	0,34	40	69	250	117
7V	0,40	48	176	635	0
	0,39	47	167	600	10
	0,38	45	153	550	22
	0,36	43	139	500	34
	0,34	41	125	450	46
	0,32	38	111	400	57
	0,30	36	97	350	67
	0,29	33	83	300	78
	0,25	29	56	200	98
6V	0,29	33	150	540	0
	0,27	32	139	500	11
	0,26	30	125	450	24
	0,24	28	111	400	34
	0,23	26	97	350	44
	0,21	24	83	300	53
	0,20	23	69	250	61
	0,19	21	56	200	70
	0,18	20	42	150	78
5V	0,20	22	129	465	0
	0,20	22	125	450	4
	0,18	21	111	400	15
	0,17	19	97	350	24
	0,16	18	83	300	32
	0,15	16	69	250	40
	0,14	15	56	200	47
	0,13	14	42	150	54
	0,12	13	28	100	60
4V	0,13	15	110	395	0
	0,12	14	97	350	8
	0,12	13	83	300	16
	0,11	12	69	250	24
	0,10	11	56	200	30
	0,10	11	49	175	33
	0,10	10	42	150	36
	0,09	9	35	125	38
	0,09	9	28	100	40
3V	0,08	8	83	300	0
	0,08	8	69	250	7
	0,07	7	56	200	13
	0,07	6	42	150	19
	0,06	5	14	50	27
2V	0,06	5	61	200	0
	0,05	5	47	170	4
	0,05	4	33	120	8
	0,05	4	19	70	12
	0,05	3	6	20	14

42NH 289 (EC brushless motor)

Speed	I	P	Qv	Qv	ESP
	(A)	(W)	(l/s)	(m³/h)	G3 Filter (Pa)
10V	0,91	116	207	745	0
	0,90	114	201	725	8
	0,88	112	194	700	17
	0,84	107	181	650	37
	0,80	102	167	600	56
	0,75	96	153	550	75
	0,71	91	139	500	93
	0,64	82	111	400	123
	0,60	76	83	300	142
	0,85	108	203	725	0
	0,83	105	194	700	9
	0,79	101	181	650	26
9V	0,75	95	167	600	45
	0,70	90	153	550	64
	0,66	85	139	500	83
	0,62	80	125	450	100
	0,59	76	111	400	115
	0,55	71	83	300	132
	0,68	85	194	680	0
	0,67	84	181	650	10
	0,65	82	167	600	24
	0,62	78	153	550	40
	0,58	73	139	500	58
	0,54	69	125	450	76
8V	0,50	64	111	400	93
	0,47	60	97	350	107
	0,45	56	83	300	118
	0,51	64	164	595	0
	0,49	62	153	550	13
	0,46	58	139	500	28
	0,43	54	125	450	45
	0,40	50	111	400	61
	0,37	46	97	350	76
	0,34	42	83	300	89
	0,32	40	69	250	100
	0,31	38	56	200	106
7V	0,38	47	140	505	0
	0,36	45	132	475	11
	0,34	42	118	425	28
	0,31	38	104	375	44
	0,28	35	90	325	58
	0,26	32	76	275	70
	0,25	30	63	225	80
	0,24	29	49	175	85
	0,18	20	42	150	78
	0,27	33	124	445	0
	0,26	32	118	425	6
	0,25	31	111	400	12
6V	0,23	28	97	350	26
	0,21	25	83	300	39
	0,19	23	69	250	50
	0,18	21	56	200	59
	0,17	20	42	150	64
	0,12	13	28	100	60
	0,18	21	100	360	0
	0,18	21	97	350	3
	0,16	19	83	300	15
	0,15	17	69	250	26
	0,14	16	63	225	31
	0,14	16	56	200	35
0,13	15	49	175	39	
0,12	14	42	150	43	
0,12	13	35	125	46	
3V	0,12	13	72	260	0
	0,11	12	56	200	10
	0,10	11	42	150	19
	0,09	9	28	100	28
	0,08	8	22	80	31
2V	0,08	7	46	165	0
	0,08	7	42	150	3
	0,07	7	35	125	8
	0,07	6	28	100	13
0,06	5	14	50	20	

PRESENTATION COOLING HEATING AIR TREATMENT CONTROLS

## 7 - 42NH AND 42NL PERFORMANCE DATA

42NH 3-5 (AC multi-speed version)

Speed	I	P	Qv	Qv	ESP
	(A)	(W)	(l/s)	(m³/h)	G3 Filter (Pa)
R1	0,88	201	199	716	0
	0,88	201	194	700	12
	0,88	200	192	690	20
	0,88	200	189	680	28
	0,87	199	186	670	37
	0,87	198	183	660	46
	0,87	197	181	650	56
	0,85	195	174	625	80
	0,84	192	167	600	105
	0,82	190	160	575	129
	0,81	186	153	550	151
	0,79	183	146	525	170
	0,77	179	139	500	186
	0,76	175	132	475	198
	0,75	173	159	572	0
0,75	173	158	570	2	
0,75	173	153	550	16	
0,75	172	147	530	32	
0,75	171	142	510	49	
R2	0,74	170	136	490	66
	0,73	168	131	470	84
	0,72	166	125	450	101
	0,71	164	119	430	118
	0,70	161	114	410	133
	0,69	158	108	390	146
	0,68	155	103	370	157
	0,67	152	97	350	166
	0,64	145	86	310	172
	0,65	150	124	448	0
0,65	150	124	445	2	
0,65	148	111	400	30	
0,64	147	106	380	41	
0,64	146	100	360	52	
0,63	144	94	340	64	
0,63	143	89	320	77	
0,62	141	83	300	91	
0,62	140	81	290	99	
0,61	139	78	280	108	
0,61	138	75	270	115	
0,61	137	72	260	121	
0,57	129	94	340	0	
0,57	128	88	315	16	
0,57	127	83	300	23	
0,56	127	81	290	27	
0,56	126	78	280	31	
0,56	125	75	270	35	
0,56	125	72	260	38	
0,56	124	69	250	43	
0,55	124	67	240	47	
0,55	124	64	230	51	
0,55	123	61	220	55	
0,55	123	58	210	61	
0,55	124	50	180	75	
0,50	111	65	233	0	
0,49	110	63	225	4	
0,49	109	56	200	15	
0,49	109	53	190	18	
0,49	109	50	180	21	
0,49	108	47	170	24	
0,49	108	44	160	27	
0,48	107	39	140	34	
0,48	107	33	120	42	
0,48	107	28	100	50	

**Key**  
**I** Current drawn by the fan motor  
**P** Power input to the fan motor  
**Qv** Air flow rate  
**ESP** Available external static pressure  
**R** Fixed speed

42NH 3-9 (EC brushless motor)

Speed	I	P	Qv	Qv	ESP
	(A)	(W)	(l/s)	(m³/h)	G3 Filter (Pa)
10V	1,34	174	278	1000	0
	1,34	174	264	950	35
	1,34	174	250	900	66
	1,34	174	236	850	95
	1,34	174	222	800	124
	1,33	173	208	750	151
	1,33	173	194	700	177
	1,32	172	181	650	201
	1,32	172	153	550	242
	1,34	174	278	1000	0
1,34	174	264	950	35	
1,34	174	250	900	66	
1,34	174	236	850	95	
1,34	174	222	800	124	
1,33	173	208	750	151	
1,33	173	194	700	177	
1,32	172	167	600	223	
1,32	172	153	550	242	
1,34	174	278	1000	0	
1,34	174	264	950	35	
1,34	174	250	900	66	
1,34	174	236	850	95	
1,34	174	222	800	124	
1,33	173	208	750	151	
1,33	173	194	700	177	
1,32	172	167	600	223	
1,32	172	139	500	258	
1,23	167	275	989	0	
1,23	167	271	975	7	
1,22	165	264	950	20	
1,20	161	250	900	45	
1,11	151	222	800	93	
1,01	140	194	700	137	
0,95	129	167	600	174	
0,91	122	139	500	201	
0,90	120	111	400	216	
0,98	136	263	945	0	
0,95	128	236	850	36	
0,91	123	222	800	56	
0,89	118	208	750	75	
0,82	113	194	700	93	
0,70	103	167	600	125	
0,68	93	139	500	149	
0,61	86	111	400	161	
0,58	81	83	300	159	
0,69	100	235	845	0	
0,68	92	222	800	12	
0,59	82	194	700	42	
0,55	75	167	600	73	
0,50	69	139	500	102	
0,45	62	111	400	127	
0,33	45	69	250	149	
0,31	41	63	225	150	
0,28	36	56	200	151	
0,41	57	197	710	0	
0,41	57	194	700	3	
0,35	51	167	600	28	
0,35	44	139	500	52	
0,31	38	111	400	73	
0,27	34	83	300	90	
0,25	32	56	200	101	
0,24	32	42	150	105	
0,24	32	36	130	105	
0,25	30	153	550	0	
0,24	28	139	500	10	
0,22	24	111	400	30	
0,17	19	69	250	54	
0,14	15	28	100	63	
0,08	9	83	300	0	
0,08	8	69	250	7	
0,08	8	56	200	13	
0,07	7	42	150	18	
0,07	7	28	100	23	





7 - 42NH AND 42NL PERFORMANCE DATA

42NH 4-5 (AC multi-speed version)

Speed	I	P	Qv	Qv	ESP
	(A)	(W)	(l/s)	(m³/h)	G3 Filter (Pa)
R1	0,72	161	369	1330	0
	0,71	158	361	1300	6
	0,67	150	333	1200	25
	0,63	142	306	1100	42
	0,60	134	278	1000	58
	0,58	128	250	900	73
	0,56	125	236	850	80
	0,55	122	222	800	87
	0,54	119	208	750	93
	0,53	117	194	700	99
	0,52	114	181	650	106
	0,50	112	167	600	111
	0,49	109	153	550	117
	0,47	105	125	450	128
	0,67	148	325	1170	0
0,65	145	319	1150	5	
0,60	134	292	1050	27	
0,55	123	264	950	47	
0,52	115	236	850	64	
0,49	107	208	750	80	
0,47	104	194	700	87	
0,46	101	181	650	94	
0,44	98	167	600	101	
0,43	95	153	550	107	
0,42	93	139	500	113	
0,40	90	125	450	120	
0,40	89	118	425	123	
0,39	88	111	400	126	
0,62	133	246	885	0	
0,57	124	236	850	16	
0,54	119	229	825	26	
0,52	114	222	800	36	
0,50	110	215	775	44	
0,48	107	208	750	51	
0,46	101	194	700	63	
0,44	97	181	650	73	
0,43	94	167	600	80	
0,41	91	153	550	87	
0,40	88	139	500	95	
0,38	84	125	450	103	
0,37	82	118	425	107	
0,36	79	111	400	113	
0,51	109	171	615	0	
0,49	104	167	600	12	
0,46	98	160	575	29	
0,44	94	153	550	44	
0,42	90	146	525	55	
0,40	86	139	500	65	
0,39	84	132	475	72	
0,38	82	125	450	79	
0,37	80	118	425	84	
0,36	78	111	400	89	
0,35	76	104	375	94	
0,34	74	97	350	99	
0,33	71	90	325	104	
0,31	68	83	300	111	
0,43	87	115	415	0	
0,42	86	111	400	8	
0,41	85	108	390	15	
0,40	84	106	380	21	
0,39	82	103	370	28	
0,39	81	100	360	36	
0,38	79	97	350	43	
0,37	78	94	340	50	
0,36	76	92	330	57	
0,35	75	89	320	63	
0,35	73	86	310	69	
0,34	72	83	300	74	
0,33	71	81	290	78	
0,32	70	78	280	81	

42NH 4-9 (EC brushless motor)

Speed	I	P	Qv	Qv	ESP
	(A)	(W)	(l/s)	(m³/h)	G3 Filter (Pa)
10V	1,34	174	292	1050	0
	1,34	174	278	1000	25
	1,34	173	264	950	54
	1,34	174	250	900	82
	1,34	174	236	850	109
	1,33	174	222	800	136
	1,33	173	208	750	163
	1,32	173	194	700	188
	1,32	172	181	650	214
	1,34	174	292	1050	0
1,34	174	278	1000	25	
1,34	173	264	950	54	
1,34	174	250	900	82	
1,34	174	236	850	109	
1,33	174	222	800	136	
1,33	173	208	750	163	
1,32	173	194	700	188	
1,32	172	181	650	214	
1,34	174	292	1050	0	
1,34	174	278	1000	25	
1,34	173	264	950	54	
1,34	174	250	900	82	
1,34	174	236	850	109	
1,33	174	222	800	136	
1,33	173	208	750	163	
1,32	173	194	700	188	
1,32	172	181	650	214	
1,29	169	291	1046	0	
1,28	167	271	975	40	
1,25	165	264	950	54	
1,12	157	236	850	103	
1,10	145	208	750	140	
1,02	134	181	650	168	
0,94	125	153	550	190	
0,93	122	139	500	198	
0,92	120	125	450	206	
1,04	140	275	991	0	
1,01	133	250	900	38	
0,98	128	236	850	58	
0,93	123	222	800	76	
0,90	118	208	750	93	
0,86	113	194	700	108	
0,78	103	167	600	135	
0,71	93	139	500	158	
0,65	86	111	400	177	
0,82	108	252	906	0	
0,71	92	222	800	33	
0,69	89	215	775	41	
0,66	87	208	750	48	
0,60	79	181	650	72	
0,56	72	153	550	92	
0,51	66	125	450	109	
0,49	62	111	400	117	
0,46	58	97	350	125	
0,46	58	211	759	0	
0,41	51	181	650	26	
0,39	49	167	600	38	
0,37	46	153	550	48	
0,35	43	139	500	58	
0,32	40	125	450	66	
0,30	37	111	400	74	
0,30	35	104	375	77	
0,29	34	97	350	81	
0,25	31	167	600	0	
0,23	27	139	500	18	
0,22	24	111	400	34	
0,19	20	83	300	46	
0,18	19	76	275	49	
0,10	10	91	327	0	
0,10	9	69	250	8	
0,09	8	56	200	12	
0,08	7	42	150	16	
0,08	7	35	125	17	

**Key**  
**I** Current drawn by the fan motor  
**P** Power input to the fan motor  
**Qv** Air flow rate  
**ESP** Available external static pressure  
**R** Fixed speed

PRESENTATION COOLING HEATING AIR TREATMENT CONTROLS

## 7 - 42NH AND 42NL PERFORMANCE DATA

42NH 5-5 (AC multi-speed version)

Speed	I	P	Qv	Qv	ESP
	(A)	(W)	(l/s)	(m³/h)	G3 Filter (Pa)
R1	0,76	168	403	1450	0
	0,74	163	389	1400	9
	0,70	154	361	1300	26
	0,67	147	333	1200	41
	0,64	140	306	1100	55
	0,61	134	278	1000	68
	0,59	128	250	900	80
	0,57	123	222	800	92
	0,54	118	194	700	105
	0,53	113	167	600	117
	0,51	108	139	500	131
	0,50	105	125	450	138
0,49	103	111	400	146	
R2	0,71	156	378	1360	0
	0,69	152	361	1300	11
	0,65	143	333	1200	28
	0,61	135	306	1100	43
	0,57	126	278	1000	57
	0,54	119	250	900	71
	0,51	112	222	800	85
	0,48	106	194	700	98
	0,48	103	167	600	112
	0,48	101	139	500	127
	0,49	102	125	450	135
	0,50	103	111	400	143
R3	0,67	147	343	1235	0
	0,65	143	333	1200	8
	0,63	137	319	1150	18
	0,60	132	306	1100	28
	0,58	128	292	1050	37
	0,56	123	278	1000	45
	0,54	119	264	950	53
	0,52	115	250	900	60
	0,51	111	236	850	67
	0,49	108	222	800	74
	0,47	101	194	700	88
	0,44	95	167	600	103
0,41	90	139	500	119	
0,39	85	111	400	137	
R4	0,64	137	299	1075	0
	0,63	134	292	1050	7
	0,59	127	278	1000	20
	0,56	122	264	950	32
	0,54	116	250	900	43
	0,51	111	236	850	52
	0,49	107	222	800	61
	0,47	103	208	750	70
	0,46	100	194	700	77
	0,45	97	181	650	85
	0,43	92	153	550	98
	0,41	89	111	400	122
R5	0,59	123	247	890	0
	0,55	116	236	850	15
	0,51	109	222	800	31
	0,48	104	208	750	45
	0,46	99	194	700	56
	0,44	95	181	650	66
	0,42	92	167	600	75
	0,41	89	153	550	83
	0,39	86	139	500	91
	0,38	84	132	475	95
	0,37	82	125	450	99
	0,35	77	111	400	108

**Key**  
**I** Current drawn by the fan motor  
**P** Power input to the fan motor  
**Qv** Air flow rate  
**ESP** Available external static pressure  
**R** Fixed speed

42NH 5-9 (EC brushless motor)

Speed	I	P	Qv	Qv	ESP
	(A)	(W)	(l/s)	(m³/h)	G3 Filter (Pa)
10V	1,88	252	513	1845	0
	1,88	252	500	1800	17
	1,88	252	472	1700	51
	1,88	249	444	1600	77
	1,87	242	417	1500	98
	1,80	232	389	1400	114
	1,72	219	361	1300	127
	1,52	190	306	1100	151
	1,31	159	250	900	181
	1,85	236	506	1820	0
	1,84	235	500	1800	5
	1,79	228	472	1700	30
9V	1,73	221	444	1600	53
	1,68	213	417	1500	74
	1,62	205	389	1400	92
	1,49	187	333	1200	125
	1,35	167	278	1000	152
	1,21	147	222	800	176
	1,58	198	481	1730	0
	1,56	195	472	1700	6
	1,49	187	444	1600	24
	1,43	178	417	1500	42
	1,31	162	361	1300	75
	1,20	146	306	1100	105
8V	1,08	130	250	900	132
	0,97	115	194	700	154
	0,85	100	139	500	172
	1,27	156	431	1550	0
	1,22	150	417	1500	9
	1,15	139	389	1400	26
	1,08	130	361	1300	43
	1,03	123	333	1200	58
	0,98	116	306	1100	72
	0,93	110	278	1000	86
	0,84	98	222	800	108
	0,65	73	139	500	134
7V	0,95	112	383	1380	0
	0,92	108	375	1350	5
	0,89	103	361	1300	12
	0,77	89	306	1100	39
	0,73	83	278	1000	52
	0,69	79	250	900	63
	0,66	74	222	800	74
	0,62	70	194	700	84
	0,45	49	111	400	108
	0,69	100	235	845	0
	0,68	92	222	800	12
	0,59	82	194	700	42
0,55	75	167	600	73	
6V	0,50	69	139	500	102
	0,45	62	111	400	127
	0,33	45	69	250	149
	0,31	41	63	225	150
	0,28	36	56	200	151
	0,49	54	281	1010	0
	0,48	53	278	1000	1
	0,39	42	250	900	11
	0,32	34	222	800	21
	0,28	29	194	700	29
	0,25	26	167	600	37
	0,24	25	139	500	44
0,25	25	111	400	49	
0,26	26	83	300	54	
5V	0,24	25	213	765	0
	0,24	24	208	750	2
	0,22	23	194	700	6
	0,19	18	139	500	21
	0,14	14	69	250	33
	0,12	11	143	515	0
	0,12	11	139	500	1
	0,11	10	111	400	7
	0,10	9	83	300	12
	0,09	7	42	150	18

## 7 - 42NH AND 42NL PERFORMANCE DATA

42NH 6-5 (AC multi-speed version)

Speed	I	P	Qv	Qv	ESP	
	(A)	(W)	(l/s)	(m³/h)	G3 Filter (Pa)	
R1	1,55	350	643	2315	0	
	1,55	348	639	2300	4	
	1,48	334	611	2200	23	
	1,43	321	583	2100	40	
	1,37	309	556	2000	55	
	1,32	297	528	1900	67	
	1,27	286	500	1800	78	
	1,22	276	472	1700	88	
	1,18	266	444	1600	96	
	1,14	257	417	1500	103	
	1,10	248	389	1400	109	
	1,06	239	361	1300	115	
	0,95	215	278	1000	132	
	R2	1,38	298	556	2000	1
1,29		280	528	1900	31	
1,22		263	500	1800	52	
1,15		248	472	1700	66	
1,08		234	444	1600	77	
1,03		222	417	1500	85	
0,97		211	389	1400	92	
0,92		200	361	1300	99	
0,88		190	333	1200	107	
0,83		180	306	1100	116	
0,79		170	278	1000	125	
0,74		161	250	900	133	
0,70		151	222	800	139	
R3		1,28	274	454	1635	0
	1,24	264	444	1600	13	
	1,12	240	417	1500	41	
	1,07	229	403	1450	51	
	1,03	220	389	1400	60	
	0,99	211	375	1350	66	
	0,95	203	361	1300	73	
	0,92	196	347	1250	78	
	0,88	189	333	1200	84	
	0,86	183	319	1150	90	
	0,83	177	306	1100	95	
	0,78	167	278	1000	107	
	0,67	144	222	800	126	
	R4	1,11	227	305	1097	0
1,06		218	299	1075	31	
1,02		209	292	1050	53	
0,98		201	285	1025	65	
0,95		194	278	1000	72	
0,92		188	271	975	76	
0,89		183	264	950	80	
0,87		179	257	925	85	
0,86		175	250	900	89	
0,84		172	243	875	94	
0,83		169	236	850	99	
0,81		166	229	825	104	
R5		0,96	188	201	723	0
		0,94	183	199	715	23
	0,89	175	194	700	50	
	0,87	170	192	690	59	
	0,85	166	189	680	65	
	0,83	163	186	670	69	
	0,82	160	183	660	73	
	0,81	158	181	650	77	
	0,79	155	178	640	82	
	0,78	153	175	630	87	
	0,77	151	172	620	91	
	0,76	149	169	610	96	

42NH 6-9 (EC brushless motor)

Speed	I	P	Qv	Qv	ESP	
	(A)	(W)	(l/s)	(m³/h)	G3 Filter (Pa)	
10V	2,01	280	522	1880	0	
	1,97	275	514	1850	8	
	1,91	266	500	1800	21	
	1,80	251	472	1700	45	
	1,72	239	444	1600	67	
	1,65	229	417	1500	87	
	1,59	221	389	1400	105	
	1,54	213	361	1300	121	
	1,35	183	278	1000	157	
	9V	1,77	238	506	1820	0
		1,75	235	500	1800	4
		1,64	221	472	1700	26
		1,56	209	444	1600	45
		1,49	200	417	1500	63
1,44		192	389	1400	80	
8V	1,34	177	333	1200	110	
	1,22	161	278	1000	138	
	1,13	150	250	900	151	
	1,42	194	450	1620	0	
	1,39	190	444	1600	4	
	1,22	167	403	1450	37	
7V	1,11	152	361	1300	64	
	1,04	141	319	1150	86	
	0,98	133	278	1000	105	
	0,92	124	236	850	121	
	0,83	111	194	700	137	
	0,69	92	153	550	152	
6V	1,02	141	403	1450	0	
	0,97	133	389	1400	10	
	0,89	121	361	1300	29	
	0,83	112	333	1200	46	
	0,79	106	306	1100	61	
	0,75	102	278	1000	74	
5V	0,72	98	250	900	86	
	0,67	92	208	750	101	
	0,43	54	111	400	124	
	0,71	93	361	1300	0	
	0,68	88	333	1200	18	
	0,64	83	306	1100	33	
4V	0,60	78	278	1000	46	
	0,55	73	250	900	56	
	0,51	68	222	800	65	
	0,47	63	194	700	75	
	0,44	58	167	600	85	
	0,39	45	97	350	105	
3V	0,50	69	319	1150	0	
	0,49	65	306	1100	6	
	0,46	59	278	1000	19	
	0,43	54	250	900	30	
	0,40	50	222	800	40	
	0,38	47	194	700	48	
2V	0,35	46	256	920	0	
	0,35	46	256	920	0	
	0,33	44	250	900	3	
	0,28	36	222	800	14	
	0,25	31	194	700	23	
	0,23	29	167	600	30	
1V	0,22	28	139	500	36	
	0,21	25	111	400	42	
	0,18	21	83	300	47	
	0,17	19	75	270	49	
	0,19	22	194	700	0	
	0,16	19	167	600	9	
0.5V	0,14	17	139	500	16	
	0,13	15	111	400	21	
	0,11	12	56	200	29	
	0,09	10	139	500	0	
	0,09	10	125	450	3	
	0,08	9	97	350	8	
0.2V	0,08	8	69	250	12	
	0,07	7	42	150	15	

**Key**  
**I** Current drawn by the fan motor  
**P** Power input to the fan motor  
**Qv** Air flow rate  
**ESP** Available external static pressure  
**R** Fixed speed

## 7 - 42NH AND 42NL PERFORMANCE DATA

42NH7-5 (AC multi-speed version)

Speed	I	P	Qv	Qv	ESP	
	(A)	(W)	(l/s)	(m³/h)	G3 Filter (Pa)	
R1	2.03	456	785	2830	0	
	2.01	451	778	2800	3	
	1.94	435	750	2700	14	
	1.87	419	722	2600	24	
	1.80	404	694	2500	34	
	1.73	390	667	2400	43	
	1.61	361	611	2200	60	
	1.49	335	556	2000	76	
	1.38	311	500	1800	90	
	1.27	287	444	1600	103	
	1.18	266	389	1400	115	
	1.09	246	333	1200	127	
	1.00	227	278	1000	138	
	R2	1.74	385	629	2265	0
		1.68	371	611	2200	10
1.59		350	583	2100	24	
1.50		331	556	2000	38	
1.42		313	528	1900	50	
1.34		296	500	1800	61	
1.27		281	472	1700	72	
1.20		266	444	1600	81	
1.14		252	417	1500	90	
1.09		240	389	1400	98	
1.03		228	361	1300	106	
0.98		217	333	1200	113	
0.82		180	222	800	138	
R3		1.40	302	390	1405	0
		1.39	300	389	1400	2
	1.24	267	361	1300	39	
	1.11	239	333	1200	67	
	1.00	216	306	1100	88	
	0.91	197	278	1000	102	
	0.87	189	264	950	108	
	0.84	182	250	900	113	
	0.81	175	236	850	118	
	0.78	169	222	800	122	
	0.76	164	208	750	127	
	R4	1.08	229	219	790	0
		1.06	224	217	780	16
		1.04	219	214	770	30
		1.01	215	211	760	43
0.99		210	208	750	54	
0.97		206	206	740	64	
0.95		202	203	730	72	
0.93		198	200	720	80	
0.93		196	199	715	83	
0.92		194	197	710	86	
0.90		190	194	700	92	
0.83		175	181	650	108	
0.77		163	167	600	114	
R5		0.84	175	149	537	0
		0.83	172	147	530	9
	0.81	169	144	520	21	
	0.80	165	142	510	32	
	0.78	162	139	500	42	
	0.77	159	136	490	52	
	0.75	156	133	480	60	
	0.74	153	131	470	68	
	0.73	151	128	460	75	
	0.71	148	125	450	81	
	0.70	146	122	440	87	

**Key**  
**I** Current drawn by the fan motor  
**P** Power input to the fan motor  
**Qv** Air flow rate  
**ESP** Available external static pressure  
**R** Fixed speed

42NH 7-9 (EC brushless motor)

Speed	I	P	Qv	Qv	ESP	
	(A)	(W)	(l/s)	(m³/h)	G3 Filter (Pa)	
10V	1.85	247	635	2285	0	
	1.79	247	625	2250	9	
	1.78	246	583	2100	40	
	1.71	236	528	1900	72	
	1.60	219	472	1700	94	
	1.38	185	389	1400	114	
	1.11	148	306	1100	126	
	0.86	114	222	800	136	
	9V	1.78	247	635	2285	0
		1.79	247	625	2250	9
1.78		246	583	2100	40	
1.71		236	528	1900	72	
1.60		219	472	1700	94	
1.38		185	389	1400	114	
1.11		148	306	1100	126	
0.86		114	222	800	136	
8V		1.38	187	547	1980	0
		1.38	186	542	1960	6
	1.36	185	528	1900	19	
	1.30	176	472	1700	59	
	1.23	166	417	1500	86	
	1.15	154	361	1300	104	
	1.04	140	306	1100	117	
	0.93	123	250	900	128	
	0.86	114	222	800	134	
	7V	1.11	142	517	1860	0
1.11		142	514	1850	2	
1.11		142	500	1800	13	
1.06		137	444	1600	48	
0.98		129	389	1400	70	
0.89		119	333	1200	85	
0.80		107	278	1000	97	
0.71		94	222	800	109	
0.67		88	194	700	115	
6V		0.85	106	469	1690	1
	0.84	106	458	1650	8	
	0.84	105	444	1600	16	
	0.82	103	417	1500	30	
	0.79	100	389	1400	42	
	0.76	96	361	1300	51	
	0.73	91	333	1200	59	
	0.66	82	278	1000	71	
	0.51	61	167	600	95	
	5V	0.59	72	406	1460	0
0.58		72	389	1400	10	
0.57		70	361	1300	22	
0.54		67	333	1200	32	
0.52		64	306	1100	40	
0.49		59	278	1000	45	
0.46		55	250	900	49	
0.42		51	222	800	53	
0.34		41	139	500	69	
4V		0.38	45	329	1185	0
	0.37	44	319	1150	5	
	0.35	41	278	1000	21	
	0.33	39	250	900	28	
	0.31	36	222	800	32	
	0.29	34	194	700	36	
	0.27	31	167	600	41	
	0.22	25	111	400	50	
	0.26	26	83	300	54	
	3V	0.22	25	247	890	1
0.21		23	222	800	11	
0.18		20	167	600	21	
0.16		18	111	400	28	
0.16		17	83	300	31	
2V		0.11	11	164	590	0
		0.11	11	153	550	4
		0.10	10	139	500	8
		0.10	9	111	400	12
		0.08	7	56	200	18





**NEW**

## VENTILATION UNIT WITH HEAT RECOVERY



- Plug & Play
- Horizontal (false ceiling or floor mounted) & Vertical (floor mounted) versions
- Indoor or outdoor installations
- Slim AHU ideal for tertiary applications installations
- Cross flow high efficiency heat exchanger
- EC fans (metallic)
- Bypass free-cooling
- Pre-parametrized controller embedded
- Easy Maintenance

# 39CS

Air flow capacity: up to 3200 m<sup>3</sup>/h

### USE

Designed for spaces where fresh air exchange is required by regulations or simply to improve livability, 39CS allows the recovery of up to 95% of the heat present in the expelled air.

The aluminum plate heat exchanger operates in counterflow mode, making it possible to maintain a nearly constant temperature gradient between the supply and return flows, thus guaranteeing a very high exchange efficiency. The heat exchanger's performance is Eurovent certified. Proper air ventilation is guaranteed by means of two ventilation sections with directly coupled motors of BLDC (BrushLess Direct Current) type with built-in inverter.

39CS range is suitable for installation in service sector spaces such as: cafes, offices, restaurants, meeting rooms, shops, school buildings, gyms, homes for the elderly, low energy buildings, and in general facilities where it is important to ensure proper air ventilation and minimize energy consumption.

### RANGE

39CS range has two versions, horizontal (false ceiling or floor mounted) or vertical floor mounted. Range is able to provide from 500 to 3200 m<sup>3</sup>/h

## DESCRIPTION

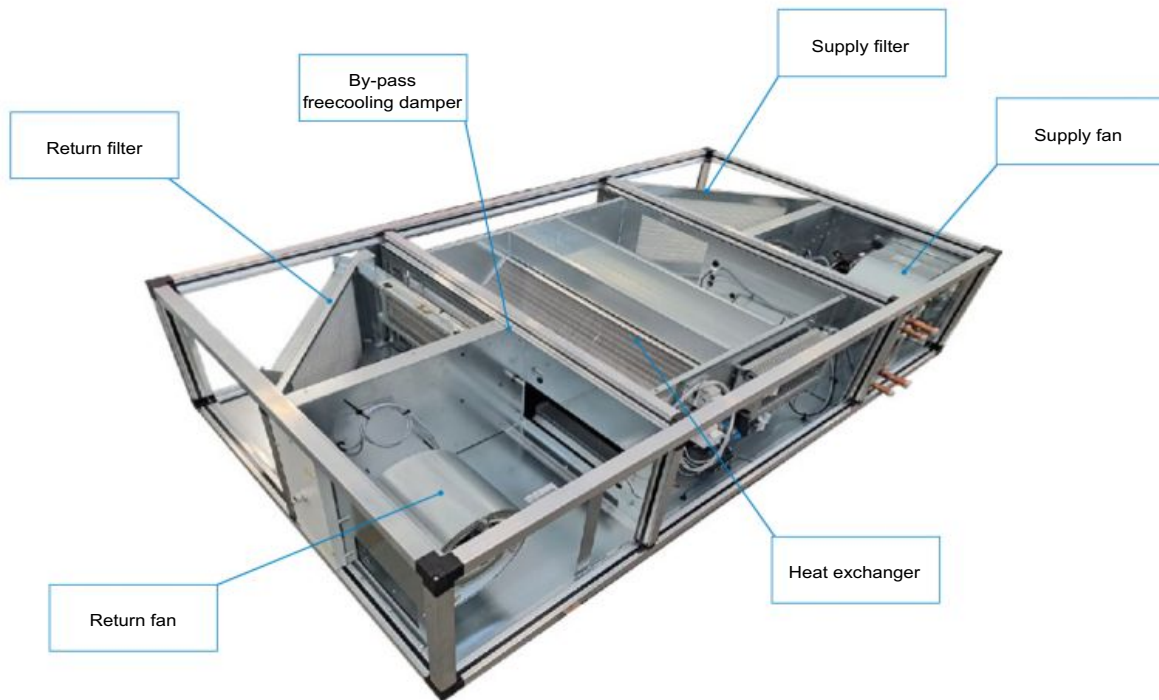

### Casing Construction Features

Sandwich-type internal galvanized steel and external pre-painted galvanized steel panel, 30 mm thick, and rock wool insulation (fire reaction class A1). Thermal insulation section with rounded internal edge and pre-loaded nylon corners.

- Thermal Transmittance: T3
- Thermal Bridge class: TB3
- Leakage: L1
- Mechanical stability: D2
- Filter bypass leakage: F9

### Dampers

By-pass for free cooling

Damper HRS by-pass (Class 2 per EN 1751:2014). Thickness is 50 mm. Height depends on sizes (servomotors are optional).

Dampers fresh air and exhaust air (Class 2 per EN 1751:2014) Thickness is 50 mm std with servomotors (optional).

### Filters

Filter M6 (ePM10 80%) return, EN 16890

High-efficiency filtering section on the fresh air Class F7 (EPM 1 50% ; EN 16890) (filter F9 EPM1 85% EN 16890 is optional) (the F9 filter is in place of the F7 filter).

Filter clogging pressure switches

### Ventilation

"Direct driven" EC type

1 supply fan and 1 return fan (both metallic fans)

EC motor (electronically commutated motor with built-in variable speed control).

### Heat recovery

Counterflow heat recuperator, with aluminium frame, aluminium heat exchanger block with selfdistanced fins and sealed at the ends in order to prevent contamination of the fresh air by the expelled air. Condensate collection and epoxy pre-coated black sheet drainage container. Minimum heat efficiency 73%, complete with internal bypass damper.

2 freeze protection systems driven by anti-freeze probe:

- Standard anti-freeze system : auto-unbalancing air flows
- Electric heater : accessory

## DESCRIPTION

### Technical data

Configuration		Horizontal		Horizontal + Vertical			
Size		55	110	175	220	255	320
Rated air flow	m <sup>3</sup> h	550	1100	1750	2200	2550	3200
<b>Fans - EC</b>							
Δps (max rpm)	Pa	180	960	950	860	820	560
<b>Heat recovery units</b>							
<b>Winter operation (-10 °C, 90% / 20 °C, 50%)</b>							
Wet efficiency	%	87,7	88,3	90,3	90,3	92,7	92,0
Power recovered	kW	4,85	9,77	15,93	20,03	23,78	29,65
Recovery eff. (EN 308)	%	75,5	77,9	79,7	79,6	81,4	80,6
T delivery	°C	16,3	16,5	17,1	17,1	17,8	17,6
<b>Summer operation (35 °C, 50% / 26 °C, 60%)</b>							
Power recovered	kW	1,25	2,59	4,21	5,29	6,26	7,77
T delivery	°C	28,2	28	27,9	27,9	27,7	27,8
<b>Total power consumption</b>							
Max electrical input	kW	2,2	2,2	2,9			
Max absorbed current	A	9,7	9,7	12,6			
Fans insulation class		F					
Power supply	V/Ph (Hz)	230/1	230/1	230/1	230/1	230/1	230/1

### Coils (option)

#### Water Coil(s). Option:

- Copper tubes, aluminium fins
- Internal coil heating for all models
- Internal coil cooling/heating only for 55 - 110
- External coil cooling / heating for 175 - 220 - 255 - 320
- Condensate drain pan in epoxy pre-coated black sheet
- 2 / 3 ways modulating valves (available as optional)

#### Direct expansion Coil. Option:

- Copper tubes, aluminium fins
- Internal coil cooling / heating for 55 - 110
- External coil cooling / heating for 175 - 220 - 255 - 320
- Condensate collection and epoxy pre-coated black sheet drainage container

#### Electric Heater Options:

- Wire electric heater with galvanized steel frame, complete with:
  - Antifreeze electric heater 2 steps;
  - Heating coil electric heater 2 steps or modulating;
 (both heater are equipped with manual and automatic reset, calibrated to intervene in case of overtemperature or low ventilation).

## DESCRIPTION

### Control



Electrical box for power, control and internal regulation of the unit, including

- Single-phase power supply (230/PH+N+PE) or Three-phase power supply (400/3PH+N+PE)
- Main switch
- Protected transformer /
- Protected 24v auxiliary line
- Protection of all electrical components by circuitbreaker
- External module wired with quick connector
- Software installed and parameterized in the factory
- Remote display (with built-in temperature probe)
- Configurable output (general alarm, filter alarm, high temperature alarm, summer/Winter)

### Main functions of the control

#### Ventilation control:

- Constant speed as STD;
- Variable speed based on constant flow rate (accessory);
- Variable speed based on constant pressure (accessory);
- Variable speed based on CO<sub>2</sub>/VOC probe for IAQ control (accessory).
- Management of the by-pass damper
- Check for filter clogging
- Standard antifreeze function with flow unbalancing
- Optional antifreeze function with flow unbalancing and antifreeze electrical heater with 2 intervention steps
- Electric heating coil management with 2 steps;
- Modulating management of electric heating coil;

#### Safety thermostat of electric heater monitoring with alarm on the display

- Control software realized in 3 languages (French, Italian, English)
- Management of the water coils with modulating valves
- Management of the direct expansion coil with digital output signal or modulating analogic output signal
- Management of external dampers

## CONFIGURATIONS

### Horizontal

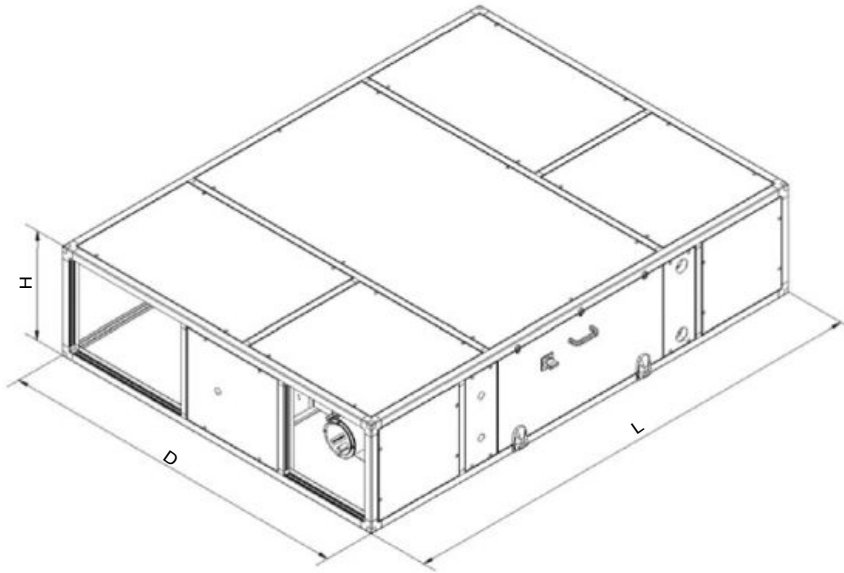

Horizontal						
39CS	55	110	175	220	255	320
Height (mm)	520 <sup>(1)</sup>	520 <sup>(1)</sup>	520 <sup>(1)</sup>	520 <sup>(1)</sup>	600 <sup>(1)</sup>	600 <sup>(1)</sup>
Length (mm)	2300	2300	2300	2300	2600	2600
Depth (mm)	1260	1260	1705	1705	2000	2000

(1) Consider the additional height of feet = 100 mm, for outdoor application

### Horizontal (with external module)

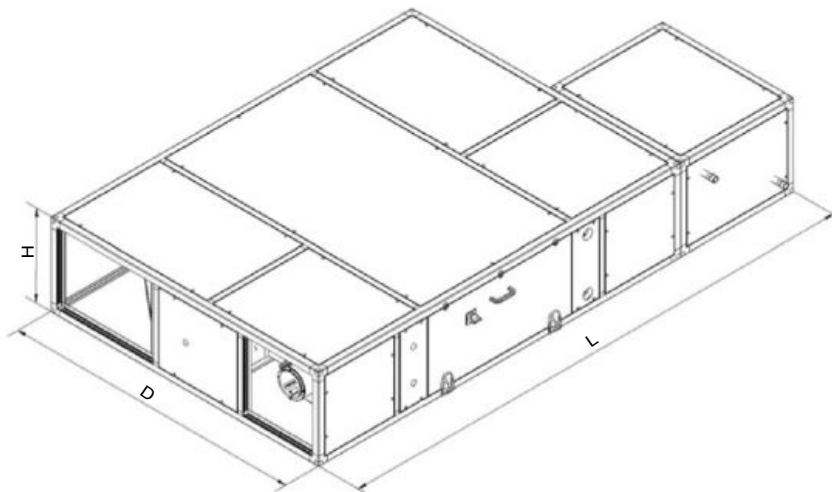

Accessories contained in the external module:

- Cooling coil (except for 55 and 110 sizes);
- Carbon filters.

Horizontal + External module						
39CS	55	110	175	220	255	320
Height (mm)	520 <sup>(1)</sup>	520 <sup>(1)</sup>	520 <sup>(1)</sup>	520 <sup>(1)</sup>	600 <sup>(1)</sup>	600 <sup>(1)</sup>
Length (mm)	2800	2800	3020	3020	3270	3270
Depth (mm)	1260	1260	1705	1705	2000	2000

(1) Consider the additional height of feet = 100 mm, for outdoor application  
 All the coils in sizes 55 & 110 are internal. No external module is required



## CONFIGURATIONS

### Vertical

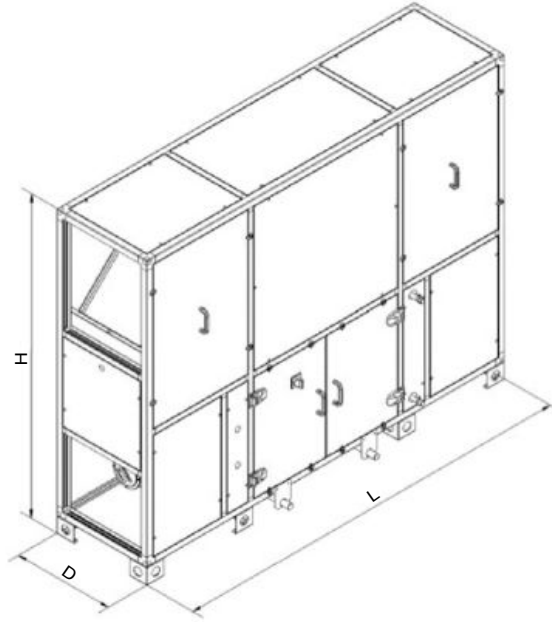

	Vertical			
39CS	175	220	255	320
Height (mm)	1805	1805	2100	2100
Length (mm)	2300	2300	2600	2600
Depth (mm)	580	580	600	600

### Vertical (with external module)

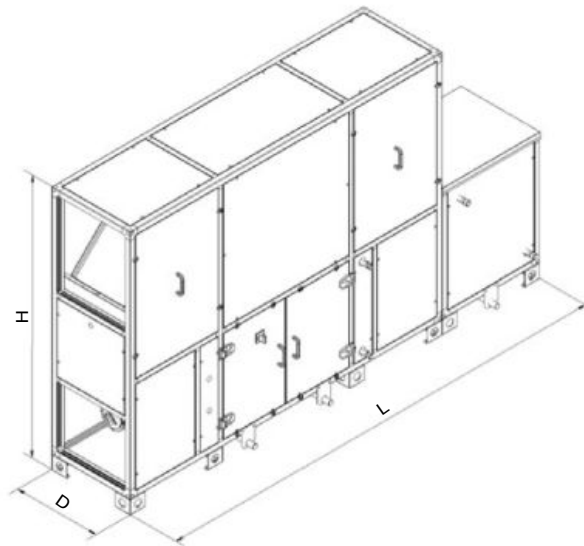

Accessories contained in the external module:

- Cooling coil;
- Carbon filters.

	Vertical + external module			
39CS	175	220	255	320
Height (mm)	1805	1805	2100	2100
Length (mm)	3020	3020	3270	3270
Depth (mm)	580	580	600	600

## CONFIGURATIONS

### Horizontal Configuration A&B

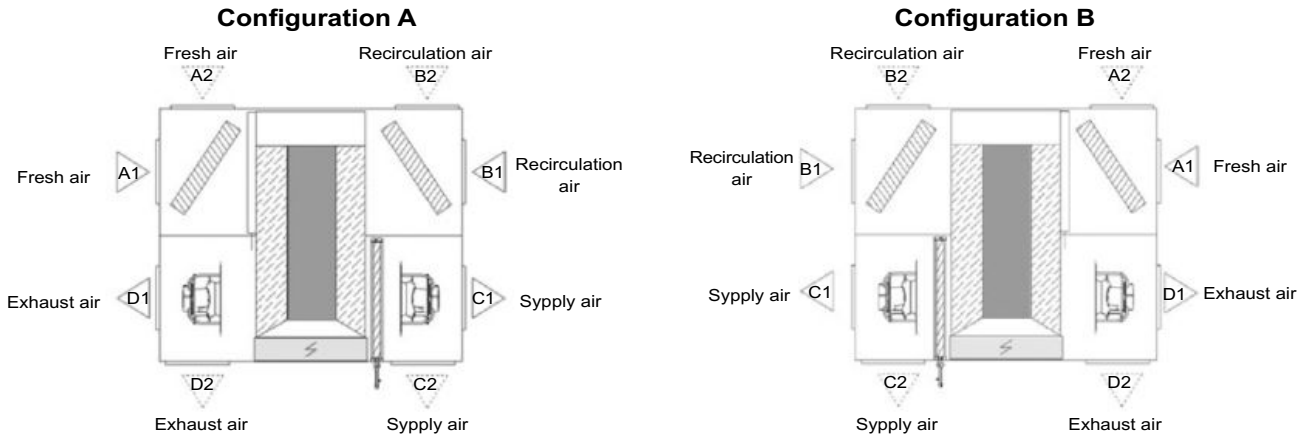

Positions A2/B2/C2/D2 are possible on-site instead of A1/B1/C1/D1 (interchangeable panels between positions 1 and 2)

### Vertical Configuration A&B

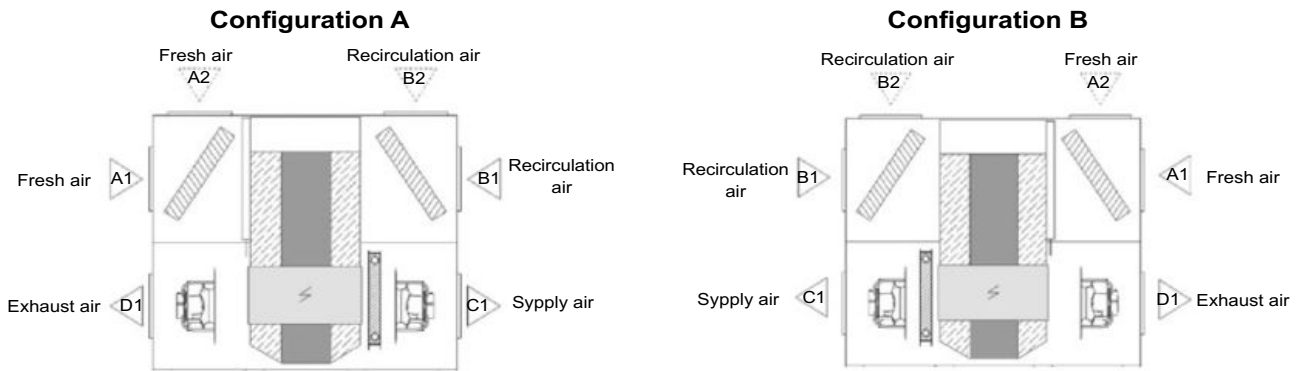

The switching of A2/B2 (instead of A1/B1) are possible on-site, only if the unit is for indoor configuration.

For outdoor configuration A2/B2 have to be requested at the order because it is not possible to switch the position on-site.

## CONFIGURATIONS & ACCESSORIES

### 1 - Application

Indoor installation  
Outdoor installation

### 2 - Layout

A orientation  
B orientation

### 3 - Air in/out-take position

Standard openings (A1/B1/C1/D1)  
Extraction opening - upside<sup>(1)</sup> (B2 in place of B1)  
Outside air opening - upside<sup>(1)</sup> (A2 in place of A1)  
Extraction and outside air opening - upside<sup>(1)</sup> (A2 and B2 in place of A1 and B1)

### 4 - Ventilation ec

Standard. EC - constant speed  
EC - constant airflow  
EC - constant pressure  
EC - quality control (only with IAQ probe (CO<sub>2</sub>/VOC))

### 5 - By-pass management

Standard - Absent (only arrangement for servomotor installation)  
ON/OFF servomotor (installed, wired and managed)

### 6 - Filtration

Standard - F7 Filter (supply air) / M6 filter (return air)  
F9 filter (supply air) / M6 filter (return air)

### 7 - Antifreeze function

Standard – by flow rates unbalance  
Antifreeze electric heater - 2 step

### 8 - Heating coil or electric heater (internal)

Standard - No  
Water coil - heating  
Electric heater - 2 step  
Electric heater - modulating (+ NTC fixed point control outlet)

### 9 - Control panel

Standard - Remote display

### 10 - Controller language

Italian  
English  
French

(1) Vertical outdoor version only

## CONFIGURATIONS & ACCESSORIES

### 11 - Cooling or mixed use coil

- Standard - No
- Water coil - cooling
- R410A coil - cooling
- Water coil - mixed use
- R410A coil - mixed use

### 12 - Water coils control

- Standard - No
- 2 ways valve 0-10V (+ NTC fixed point supply control)
- 3 ways valve 0-10V (+ NTC fixed point supply control)

### 13 - Additional purification section

- Standard - No
- Additional active carbon filter - supply air (external module)

### 14 - Structural accessories

- Standard - No
- Rain caps<sup>(2)</sup>
- Dampers on fresh and exhaust air openings (ON/OFF) with servomotor
- Circular connections
- Rain caps + Circular connections<sup>(2)</sup>
- Rain caps + dampers on fresh and exhaust air openings<sup>(2)</sup>

<sup>(2)</sup> Outdoor version only

**NOTE : For AISI304 panel material, please contact manufacturer**





## COMPACT AIR HANDLING UNIT



The modular Ultra-Slim AHU is the guaranteed perfect solution

Ideal for a compact installation

Available in single-flow or aligned or adjacent dual-flow versions

# 39CQ

Air flow: 1000-6000m<sup>3</sup>/h

The 39CQ air handling unit is a modular ventilation unit, which can be configured to meet all your requirements whilst complying with current standards.

It is available in several versions: single-flow, aligned dual-flow, adjacent dual-flow.

The 39CQ AHU is used for fresh air change, air recirculation, air extraction and air handling using its filtration, heating, cooling, recovery and ventilation functions...

## USE

There are three different installations in the range, so it can be adapted to meet your needs:

- horizontal ceiling-mounted version, accessed from underneath,
- horizontal floor-mounted version, accessed from the top,
- vertical wall-mounted version, accessed via the front.

It is available in three sizes to meet all your needs, able to handle air flows from 1000 to 6000 m<sup>3</sup>/h.

At 400 mm thick, it is ultra compact and can be fitted into the tightest of spaces.

This range is particularly well-suited to tertiary buildings:

- administration, offices,
- education facilities, libraries, community centres,
- cafés, hotels, restaurants,
- shopping centres, nursing homes, healthcare facilities,
- collective housing

All installations requiring ventilation.

## RANGE

The 39CQ range comprises 3 sizes from 1000 to 6000 m<sup>3</sup>/h. There are four standardised lengths of casing, adapted to the configuration and options selected.

The AHU will therefore comprise one or several casings, depending on your selection; 610, 830, 1100 and 1400 mm modules.

39CQ	025	040	060		
<b>Assembly</b>	Ceiling-mounted (C), Floor-mounted (F), Vertical (V)				
<b>Width/Height</b>	750*400	1310*400	1880*400		
<b>Nominal air flow (m<sup>3</sup>/h) (Speed: 3.1 m/s across finned layer)</b>	2000	4000	6000		
<b>Plug fan, AC motor</b>	Plug fan	1	1	2	2
	Electric motor	1	1	2	2
	Available power	0.55 kW - 4-pole/1.1 kW - 2-pole/1.4 kW - 2 pole			
	Number of inverters	1	1	1	1
<b>Plug fan, AC motor</b>	Plug fan	1	1	2	2
	EC motor	1	1	2	2
	Available power	1 kW			
<b>Pleated filters</b>	G4 / M5 / F7 HEE / F9 HEE				
<b>Opacimetric filters (Short flexible pockets)</b>	M6 / F7				
<b>Opacimetric filters (Rigid pockets)</b>	M6 / F7 / F8 / F9				
<b>Hydraulic heating coil</b>	1/2/3 rows	1/2/4 rows	1/2/4 rows		
<b>Hydraulic cooling coil</b>	3/4/6 rows				
<b>Direct expansion cooling oil</b>	3/6 rows				
<b>Electric heating coil</b>	15 kW	24 kW	33 kW		
<b>Adjacent plate heat exchanger</b>	Yes	Yes	No		

## DESCRIPTION

### Casing

- Double-skin panels made from sheet steel, galvanised on both sides, thickness 8/10 mm
- RAL 7035 lacquer coated finish on external panels
- M0/A1 fire rating
- Mineral wool, thickness 25 mm

### Connection and utilities

- Hydraulic connection possible on the right or left (to be specified when ordering).
- The access doors are positioned according to the choice of model:
  - horizontal ceiling-mounted model: access doors located underneath the unit,
  - horizontal floor-mounted model: access doors located on top of the unit,
  - vertical wall-mounted model: access doors on the front of the unit

### Damper

- Uncased external damper
- Damper in choice of sealing class 1 or 3, as per EN 1751
- Damper thickness 110 mm and height 310 mm
- Optional servomotor

### Filtration

- Filter cell with universal dimensions
- Three filtration stages possible per air flow rate
- Pleated filters in efficiency class G4, M5, F7 and F9 HPE
- Short bag filters in efficiency classes M6 to F7
- Rigid bag filters in efficiency classes M6 to F9
- Pressure tapping as standard on each filtration stage
- Option, pressure switch, pressure gauge, ...

## DESCRIPTION

### Heat exchange coil

- Hydraulic coil
  - Copper tubes, aluminium fins
  - Choice of 3 coil sizes for each AHU size
  - Optional frost protection thermostat with automatic reset
  - Condensate drain pan in stainless steel
- Evaporator coil
  - Copper tubes, aluminium fins
  - Choice of 3 coil sizes for each AHU size
  - Stainless condensate drain pan

- Electric heater
  - Shielded resistors in scrolled finned pipes
  - 2 high-limit safety thermostats: one automatic and one manual reset
  - Anti-radiation screen, depending on the upstream and downstream elements

#### Output power supplied by the electric heaters

AHU size	Main casing	Additional box	
	2 stages	2 stages	4 stages
025	2 * 7.5 = 15 kW	2 * 7.5 = 15 kW	4 * 7.5 = 30 kW
040	2 * 12 = 24 kW	2 * 12 = 24 kW	4 * 12 = 48 kW
060	2 * 16.5 = 33 kW	2 * 16.5 = 33 kW	4 * 16.5 = 66 kW

### Ventilation

- "Plug Fan" type direct drive FMA.
- 1 or 2 FMA for each air flow rate, depending on the size and conditions.
- Plug fan combined with a motor at the end of the shaft.
- AC motor with optional frequency inverter.
- EC motor (electronically commutated motor with built-in variable speed control).

39CQ	025	040	060	
<b>Assembly</b>	<b>Ceiling-/floor-mounted/vertical</b>			
<b>Nominal air flow (m<sup>3</sup>/h) (Speed: 3.1 m/s across finned layer)</b>	2000	4000	6000	
<b>Plug fan, AC motor</b>	Plug fan	1	2	2
	Electric motor	1	2	2
	Available power	0.55 kW - 4-pole/1.1 kW - 2-pole/1.4 kW - 2 pole		
	Number of inverters	1	1	1
<b>Plug fan, EC motor</b>	Plug fan	1	2	2
	EC motor	1	2	2
	Available power	1 kW		

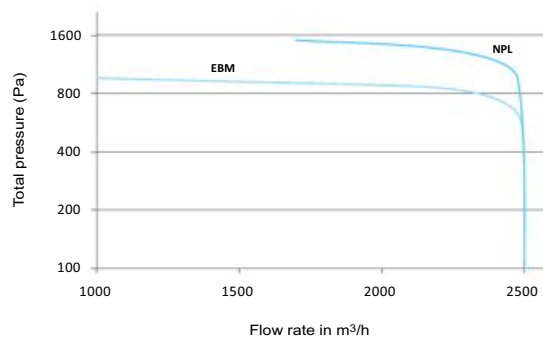
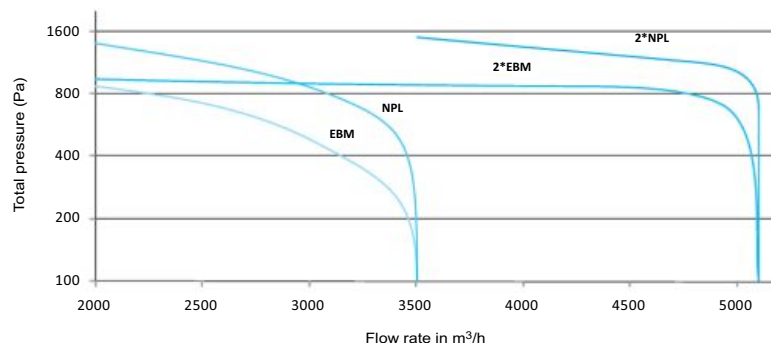
**39CQ 025**

**39CQ 040**

## DESCRIPTION

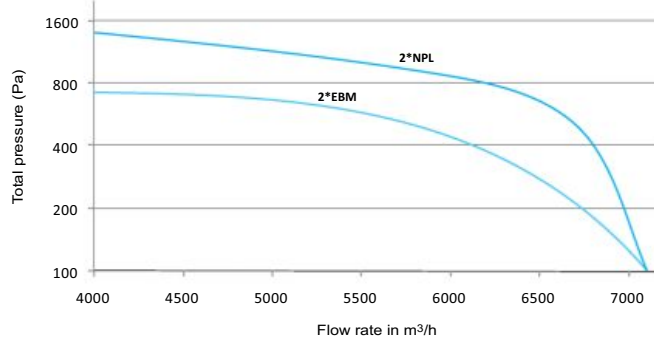
39CQ 060



### Accessories and options

- 2-channel mixing box: 3 air flow positions available
- 3-way mixing box
- Angled or straight plenum
- Sound attenuator
- Adjacent plate heat exchanger (sizes 025 and 040 only)
- Control

- peripheral options and power terminal block
- surface-mounted electric heater unit, or delivered unassembled
- control by factory preprogrammed controller, algorithm created in-house
- hand-held cabled micro-terminal
- fault summary contact
- control by constant flow/constant pressure/CO<sup>2</sup>
- pressure and temperature sensors, depending on the selection
- numerous options and functions available

### Control

- Electrics box for power, control and internal regulation of the unit, comprising as standard:
  - Three-phase 400 V power supply + Earth
  - main disconnect switch
  - protected transformer
  - protection and control of all electrical components by a circuit-breaker and switch

## SPACE REQUIREMENTS AND DIMENSIONS:

DIMENSIONAL SPECIFICATIONS			
AHU size	025	040	060
External dimensions (in mm)	750 * 400	1310 * 400	1880 * 400
Casing length (in mm)	610 - 830 - 1100 - 1400: Four standardised lengths of casing, automatically adapted to the components and options selected		

- 610 mm module ▶ 1 x 540 mm door
- 830 mm module ▶ 1 x 595 mm door
- 1100 mm module ▶ 1 x 595 mm door + 1 x 435 mm door
- 1400 mm module ▶ 1 x 595 mm door + 1 x 735 mm door

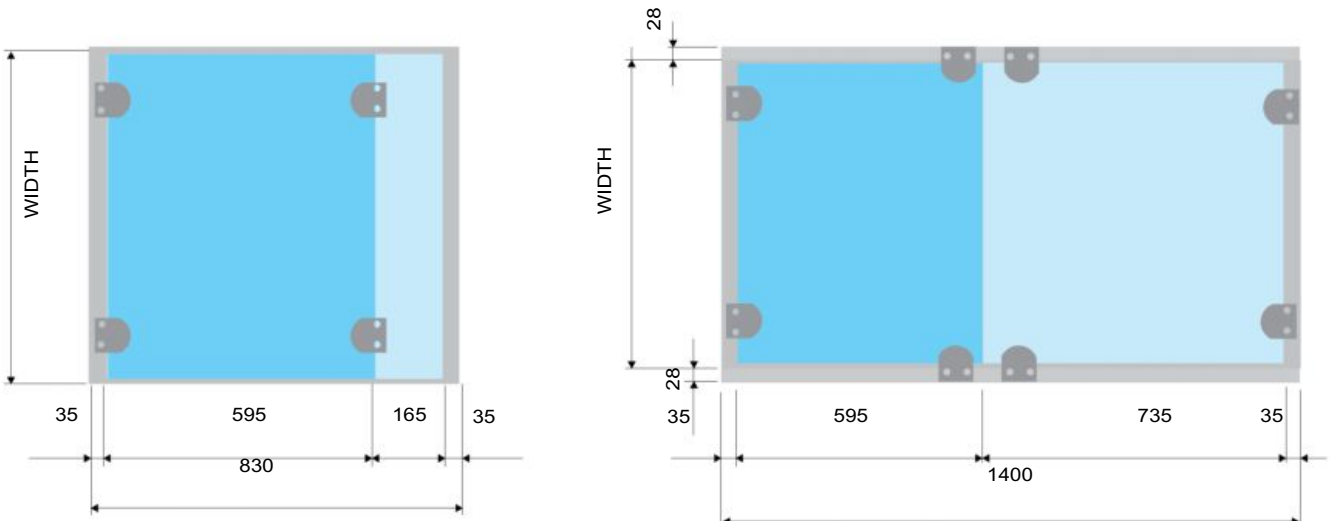

## AIR CONNECTION

### Air connection

Air connection AHU intake - AHU discharge - Mixing and plate heat exchanger

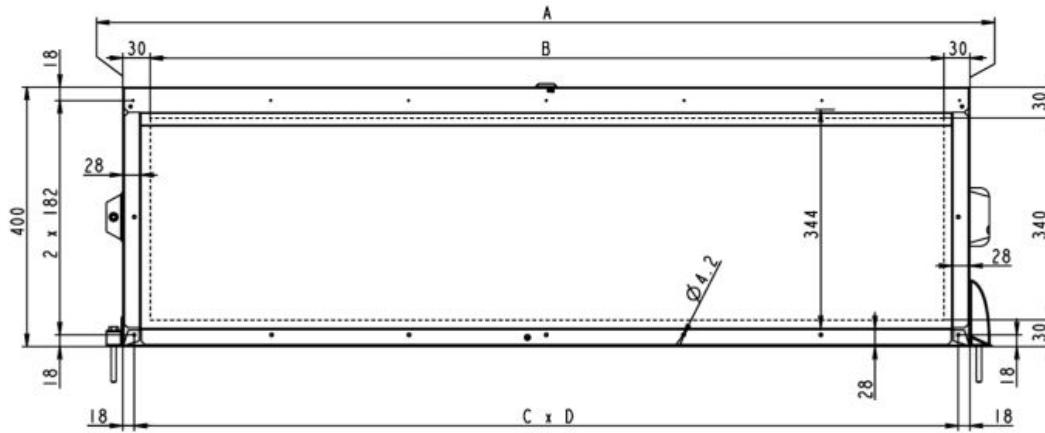

	A	B	C	D
39CQ 025	750	690	3	238
39CQ 040	1310	1250	6	212,3
39CQ 060	1880	1820	8	230,5

### Examples of compositions

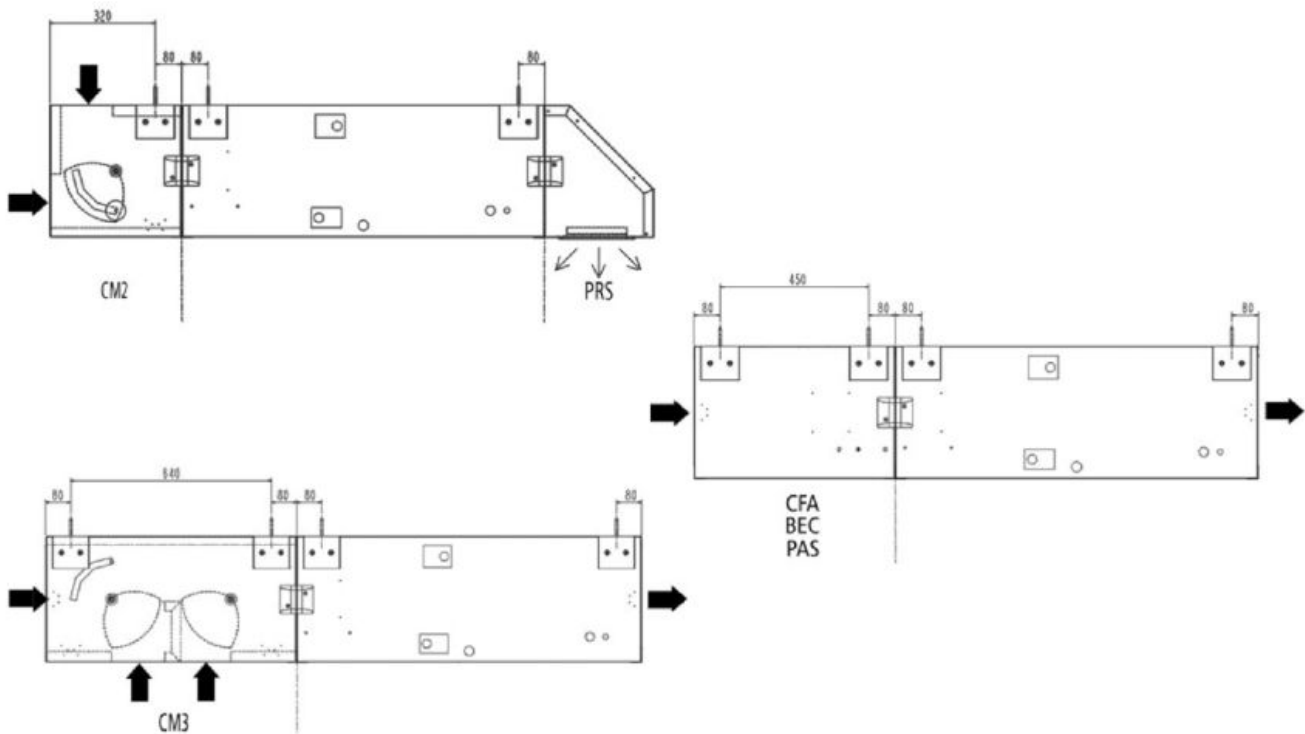





## HIGH-EFFICIENCY DUAL-FLOW AIR HANDLING UNIT



Plug & play unit  
(built-in control)

Class A+ across  
entire range

Classic / Vertical dual-flow

High-efficiency  
heat recovery unit

High performance plug fan

## 39HX

The 39HX dual-flow air handling unit is a PLUG & PLAY ventilation unit equipped with a highly efficient heat recovery unit with plug fans and high performance EC motors, designed to meet all the requirements of recent ecodesign regulations.

Unit supplied ready to use, prewired, preprogrammed in the factory and supplied with a remote control.

It draws clean, fresh air indoors using, on average, 80% less energy than that needed for air conditioning (cooling and heating).



[www.eurovent-certification.com](http://www.eurovent-certification.com)

## USE

These units are designed for use in the following applications:

- Administrative buildings, Offices
- Education facilities, Libraries, Community centres
- Cafés, Hotels, Restaurants
- Shopping Centres
- Nursing homes, Healthcare facilities
- Collective Housing

⇒ All facilities where ventilation is required.

Specifications	Class
Mechanical strength	D2
Airtightness	L1
Filter bypass leak	F9
Thermal transmission	T3
Thermal bridge	TB2

**39HXE & HXEZ models:** 9 sizes, air flow from 300 to 18,000 m<sup>3</sup>/h. Floor-mounted horizontal unit with horizontal air flows and air connections on the sides.

**39HXEZ model:** 9 sizes, air flow from 300 to 18,000 m<sup>3</sup>/h.

Wheel equipped with a purge sector as standard

**39HXA model:** 5 sizes, air flow from 350 to 8500 m<sup>3</sup>/h.

**39HXC model:** 5 sizes, air flow from 300 to 6600 m<sup>3</sup>/h.

Floor-mounted horizontal unit with horizontal air flows and air connections on the sides.

**39HXV model:** 3 sizes, air flow from 300 to 2600 m<sup>3</sup>/h. Floor-mounted vertical unit with vertical air flows and air connections on the top.

### High energy-efficiency heat recovery unit

Depending on its layout, the 39HX offers two different high-efficiency heat recovery systems:



"CONTRA FLOW" plate heat exchanger fitted with a bypass (C, V, H models)



Rotary heat exchanger (39HXA and 39HXE & HXEZ models) Optimal heat recovery all year round

## RANGE

### Classic 39HXC, 39HXE & 39HXEZ

Sizes	Nominal flow rate (m <sup>3</sup> /h)	Max. power* (kW)	Max current* (A)	Voltage (V)
010	1000	1,43	6,2	1-Ph 230  3-Ph 400
020	2000	2,50	3,6	
030	3000	3,82	5,5	
040	4000	4,23	6,1	
050	5000	4,23	6,1	
060	6000	6,03	8,7	
075	7500	6,03	8,7	
100	10000	12,06	17,4	
150	15000	15,45	22,3	

### 39HXA

Sizes	Nominal flow rate (m <sup>3</sup> /h)	Max. power* (kW)	Max current* (A)	Voltage (V)
010	1000	1,2	5,4	1-Ph 230
020	2000	2,5	2,9	
030	3000	4,2	6,1	3-Ph 400
050	5000	6,1	8,8	
075	7500	7,1	10,3	

### Vertical 39HXV

Sizes	Nominal flow rate (m <sup>3</sup> /h)	Max. power* (kW)	Max current* (A)	Voltage (V)
007	1000	1,43	6,2	1-Ph 230
015	1500	2,50	3,6	3-Ph 400
020	2000	2,50	3,6	

\* These values are provided for guidance only and are based on a standard dual-flow unit without electric heater option.

## DESCRIPTION

### Casing

- Double-skin panels made from steel sheet metal, galvanised on both sides, thickness 8/10 mm.
- RAL 7035 grey precoated external panels.
- Class M0/A1.
- Mineral wool, 50 mm thick.

### Filtration

- M5 HEE, F7 HEE, F9 HEE filters.
- Filter cells kept compressed by a special system to ensure a leaktight seal.
- HXC, HXV models: fouling value monitored by analogue sensor and displayed by the controller.
- HXA model: pressure switch control on each air flow. Pressure switch status displayed by the controller.

### Ventilation

- Plug fan driven by an electronically commutated motor (EC motor, built-in variable speed control).

### Heat recovery units

- "Contra Flow" plate heat exchanger equipped with a motorised bypass (HXC and HXV models). Efficiency greater than 80% across the range of air flows.
- Rotary heat exchanger equipped with variable rotation speed control (39HXE & HXEZ models).
  - ⇒ Efficiency greater than 80% at nominal flow rate.
- Purge sector as standard (39HXEZ model)
- Constant speed rotary heat exchanger (HXA model)
  - ⇒ Efficiency greater than 80% at nominal flow rate.

### Hydraulic coil

- Copper pipes, aluminium fins.
- Coil can be integrated or additional (cased).
- With the accessory fitted, 2- or 3-way control valve and 0-10 V actuator controlled by 39HX Control for setpoint accuracy.
- Stainless steel condensate drain pan (cooling coil or mixed coil only).

### Electric heaters

- High-limit safety thermostat with automatic and manual reset.
- Control by 2-stage on/off operation fully controlled by 39HX Control.

### DX coil

- Copper tubes, aluminium fins.
- For reversible heating/cooling operation.
- Internal space optimised for VRV units.
- Stainless steel condensate drain pan.

List of outdoor units optimised for 39HXA DX available on request.

### Electrics box

- Electrics box for power, control and internal regulation of the unit, comprising as standard:
  - Power supply (3-Ph 400 V + Earth or 1-Ph 230 V + Earth).
  - Main disconnect switch.
  - Protected transformer.
  - Protection and control of all electrical components by a circuit breaker and contact switch.
  - Peripheral options and power terminal block.
  - Factory-programmed PLC control.
  - Hand-held cabled micro-terminal.
  - Fault summary contact.
  - 3 temperature sensors.
  - 4 pressure sensors (2 pressure sensors and 2 pressure switches on the 39HXA model).
  - Control unit option for factory-fitted/wired DX unit (39HXA model)

### Accessories

- Damper formed of airfoil blades, powered by a servomotor
- On/off with return spring.
- Flexible sleeve.
- Adjustable feet.
- CO<sub>2</sub> air quality sensor.
- Roof.
- Canopy.
- Mixing section.
- Remote ambience control.
- ModBus RTU, KNX, ModBus communication
- TCP, Bacnet IP, web interface.

MODELS & SIZES	Power (kW)	Current (A)	Voltage (V)
C 010 & E & EZ 010 V 007	4,5	20	1-Ph 230
V 015 (additional casing)	7,20	11	3-Ph 400
V 015	8,1	12	
C 020 & E & EZ 020	10,8	16	
C 030 & E & EZ 030	12,6	19	
C 040 & E & EZ 040	16,8	25	
E & EZ 050	19,8	29	
C 060 & E & EZ 060	22,8	34	
E & EZ 075	31,2	46	
E & EZ 100	50	74	
E & EZ 150	65	96	

## CONTROL

### 39HX Control

The 39HX features, as standard, an electric box equipped with a factory-programmed PLC and a hand-held micro-terminal.

39HX Control function			Included	Options*	
<b>Fan time schedule</b>	Built-in timer: management in series	4 events per year, per week and per day	X		
<b>Safety</b>	Frost protection	By fresh air temperature control	X		
		By monitoring the pressure difference from the heat recovery unit on the flow of exhaust air (analogue sensor)		X	
	Monitoring of sensor status		X		
	Monitoring operation values (thresholds)		X		
	Operating control of EC fan motor assemblies		X		
	Filter fouling control (via analogue sensor or pressure switch, depending on the model)		X		
	Fault summary		X		
Fire monitoring (input available for potential free (dry) contact (normally closed))		X			
<b>Alarms</b>	Management of alarms and log (100)		X		
<b>Control mode</b>	Control of return air or supply air temperature		X		
	Regulated temperature control based on outdoor temperature		X		
	Control of room temperature with a room terminal			X	
<b>Hot air and/or cold air production</b>	Gradual action on the 2- or 3-way control valve on the hydraulic coil			X	
	Gradual action on the electric heater TRIAC			X	
	On/Off action on the various stages of the electric heater			X	
<b>DX*** coil</b>	Gradual action on a VRV outdoor unit			X	
	Heating/cooling control			X	
	Optimised defrost cycle management			X	
<b>Free cooling</b>	Shut-down of the rotary heat exchanger (HXE & HXEZ and HXA models)		X		
	Opening of the bypass on the Contra Flow plate heat exchanger (HXC and HXH models)		X		
<b>Night cooling function</b>	Shut-down of the rotary heat exchanger (HXE & HXEZ and HXA models)		X		
	Opening of the bypass on the Contra Flow plate heat exchanger (HXC and HXH models)		X		
<b>Efficiency optimisation</b>	Variation of the rotation speed of the rotary recovery unit (HXE & HXEZ model)		X		
<b>Configuration of the air flow rate</b>	2 air flow rate setpoints per air flow		X		
	Display of the air flow rate		X		
<b>Constant flow rate operation</b>	Keeps the air flow rate constant regardless of how fouled the filters are		X		
<b>Modulation of flow rates operation</b>	Single zone	0-10V signal		X	
		Contact	CO <sub>2</sub> sensor	X	
	Multi zone	Air supply duct constant pressure operation		X	
		ModBus RS485 protocol		X	
<b>Communicating mode</b>	Management by CMS	KNX protocol		X	
		ModBus TCP/BACNET IP protocol		X	
		Web interface		X	
		Colour touchscreen interface with synoptic			X
<b>Miscellaneous</b>	Languages supported (French/English/German/Dutch/Spanish/Italian)		X		
	Integrated temperature sensors (*3: fresh air supply and extraction, exhaust air extraction)		X		
	Integrated pressure checks (*4: fresh air and exhaust air filter fouling level, fresh air and exhaust air fan)		X		
	Damper control			X	
	Information provided to the user via the hand-held micro terminal		X		
	Contact for controlling the pumps for the hydraulic coils (with operating control)**		X		
	Contact for controlling an external outdoor heat production system (boiler, etc.)**		X		
Contact for controlling a humidifier**		X			
Electric heater load shedding input**		X			

Option\*: Requires the component to be selected as an option: damper, coil, CO<sub>2</sub> sensor, etc.

\*\* Except 39HXA model

\*\*\* Only available on the 39HXA model



## AIR FLOW DIMENSIONS AND ORIENTATION

### Classic 39HXC, 39HXE & HXEZ & 39HXA

Sizes	39HXC, 39HXE & HXEZ & 39HXA									
	Height (C) (mm)	Width (B) (mm)	Length (A) (mm)				Weight (kg)*			
			HXC	HXA	HXE	HXEZ	HXC	HXA	HXE	HXEZ
010	958	810	1580	1266**	1266	1480	200	180	201	273
020	1158	1010	1150 + 800	1310**	510+800	800+800	350	250	309	382
030	1359	1210	1264 + 800	1600	800+800	1264+800	465	330	432	556
040	1659	1510	1264 + 800	-	800+800	1264+800	580	-	558	654
050	1659	1510	-	1600	800+800	1264+800	-	445	604	704
060	1959	1810	1407 + 800	-	800+800	1407+800	765	-	702	742
075	1959	1810	-	1600	800+800	1407+800	-	580	751	811
100	2090	1920	-	-	1100+1100	1820+1100	-	-	955	1065
150	2340	2192	-	-	1100+1200	1820+1200	-	-	1250	1357

\* Without internal option.

\*\* Circular coupling; protrudes 47 mm on either side.

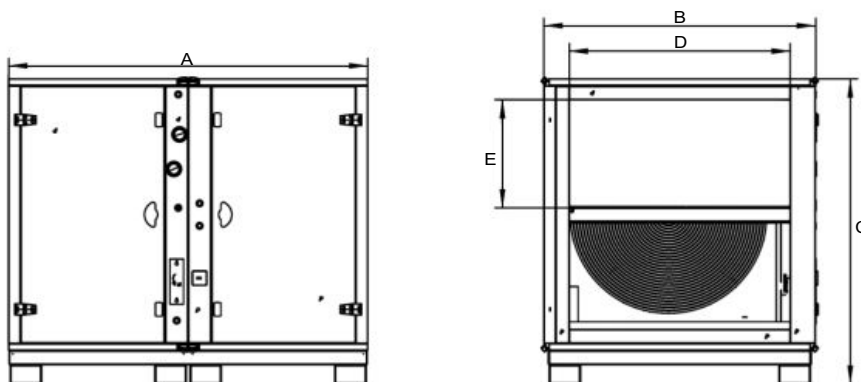

## AIR FLOW ORIENTATION

### 39HXE & HXEZ, 39HXA models

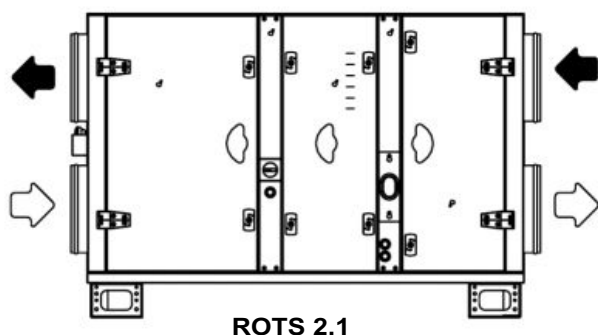

ROTS 2.1

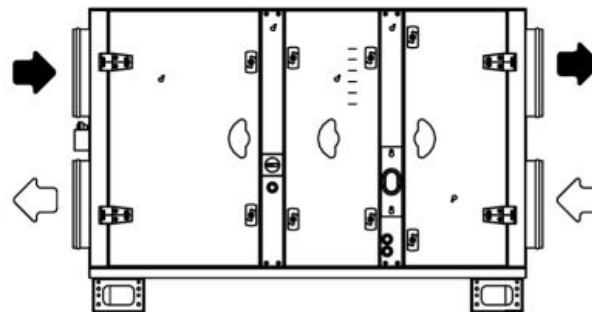

ROTS 2.2

WHITE ARROW = FRESH AIR  
 BLACK ARROW = EXTRACTED AIR

### 39HXC models

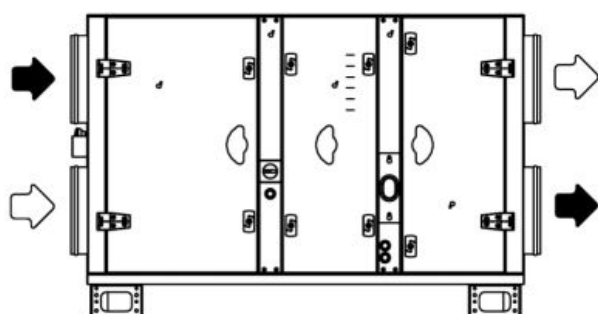

PLAS01

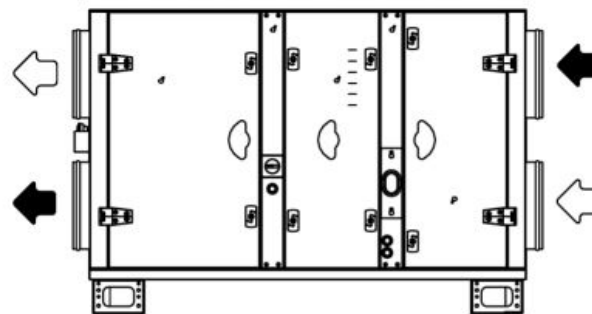

PLAS02

## AIR FLOW DIMENSIONS AND ORIENTATION

### Vertical 39HXV

Sizes	Dimensions			Weight (kg)*
	Height	Length	Width	
007	1385	1313	730	202
015	1758	1593	832	330
020	1901	1735	832	389

\* Without internal option

#### Size 007

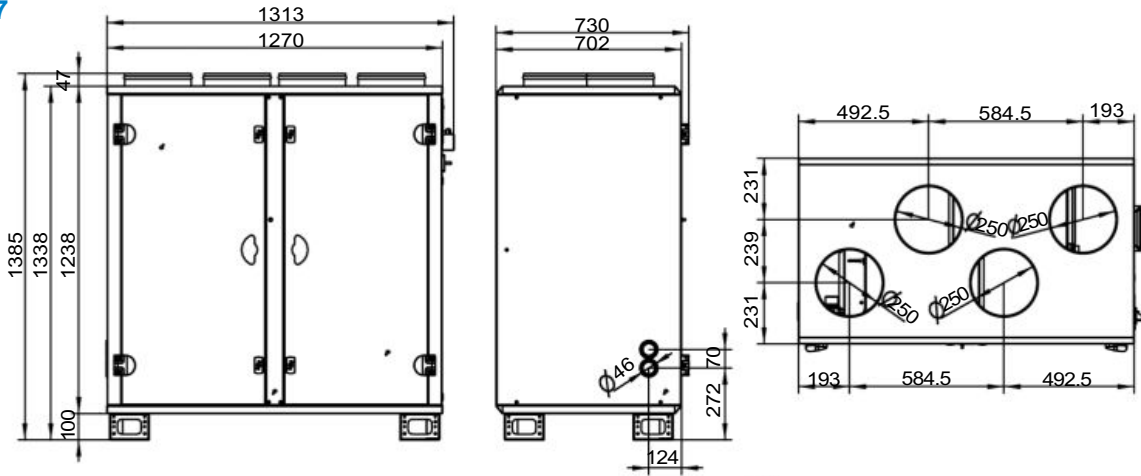

#### Size 015

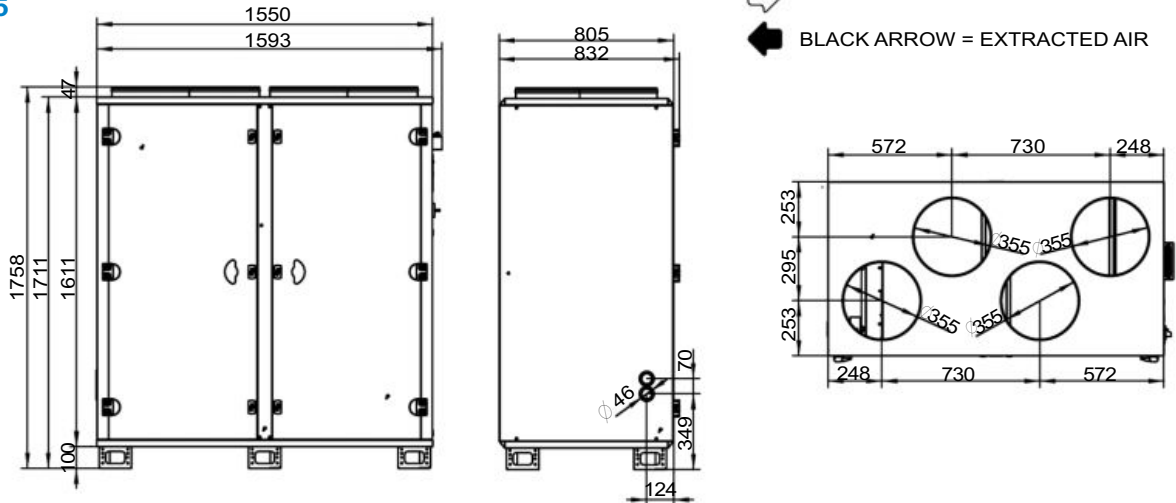

#### Size 020

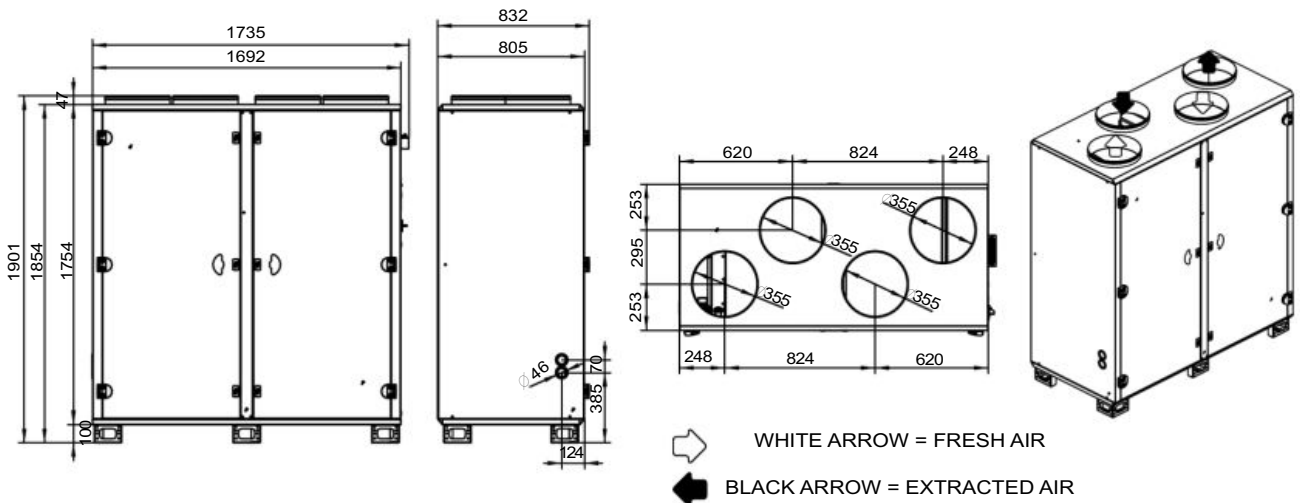

## AIR FLOW DIMENSIONS AND ORIENTATION

Additional casing (MUST ONLY BE POSITIONED IN A HORIZONTAL AIR FLOW)

39HX MODELS	Additional casing sizes (mm)	Weight (kg)
E & EZ 010 & C 010 V 007	Size 1 589 x 400 x 810	49 kg
E & EZ 020 & C 020 V 015 & V 020	Size 2 689 x 400 x 1010	62 kg
E & EZ 030 & C 030	Size 3 759 x 400 x 1210	68 kg
E & EZ 040 & E & EZ 050 C 040 & C 050	Size 4 909 x 400 x 1510	88 kg
E & EZ 060 & E & EZ 075 C 060 & C 075	Size 5 1059 x 400 x 1810	112 kg

Size 1

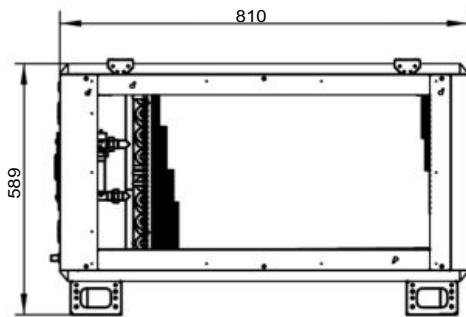

Size 2

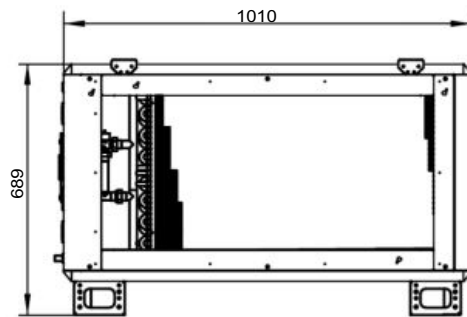

Size 3

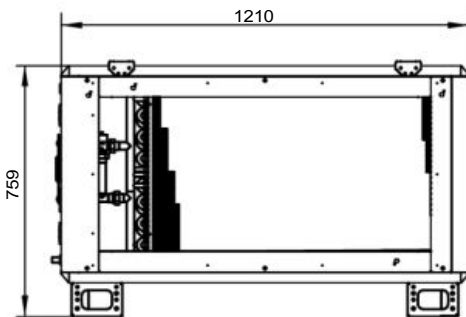

Size 4

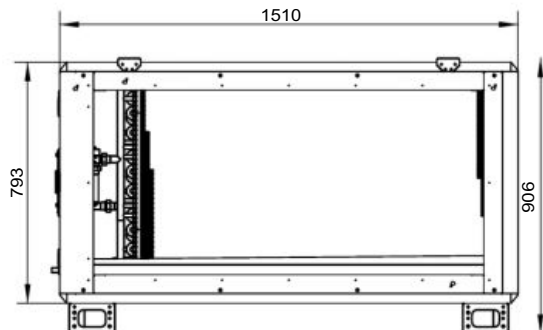

Size 5

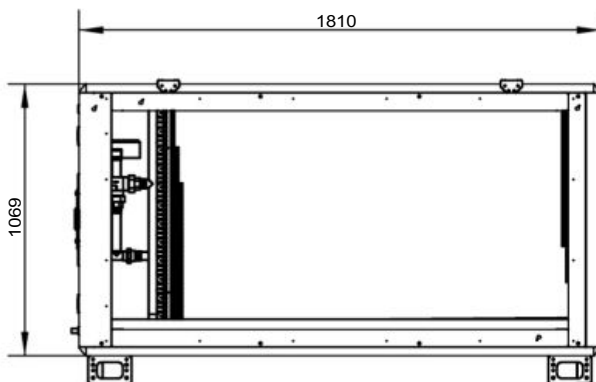



## AIR HANDLING UNIT



AHU for multiple applications

Designed to conform to standards EN 13053 and EN 1886

For all service sector, industry and healthcare environments

39CP C hygienic version

VDI 6022 option.

# 39CP

Air flow: 1000 to 30,000m<sup>3</sup>/h

### Air handling unit: 39CP

The new range of 39CP air handling units is the latest generation of AHUs developed to meet the EN 1886 and EN13053 standards, integrating the most innovative components (high efficiency filters, heat recovery systems, EC fans, variable speed controllers, etc.).

This range has been designed to meet rigorous and stringent environmental requirements. As confirmation of its quality processes, the production facility has received certifications in the following standards: ISO 9001, ISO14001, ISO18001.

The 39CP range has EUROVENT AHU programme certification. This generation has been designed to meet these criteria, providing a high level of thermal classification, and ensuring it is suited for every application.

The range was developed by the European Air Side research and test center. It was designed using cutting edge digital resources, and all steps were confirmed by testing in climatic test and acoustic chambers.

The test center also enables CARRIER to offer its customers performance tests on manufactured products before they leave the facility in certain cases.

The painting, machining, panelwork, frame, fitting of gaskets, welding, and control tests are performed on production lines devoted entirely to the 39CP range.

The facility also produces air-water or refrigerant exchangers. Carrier uses its own calculating and sizing tools.

These factors give Carrier complete control of both its performances and its procurement cycles.

All of the above aspects combine to help create a high quality product which gives you complete satisfaction in a diverse range of applications, from offices and service sector administration to industrial processes and controlled environments in industry, satisfying also the healthcare requirements.



CARRIER participates in the ECP programme for 39CP range Check ongoing validity of certificate: [www.eurovent-certification.com](http://www.eurovent-certification.com)



## USE

The 39CP range is designed for the service, industry and healthcare sector to meet different requirements in terms of air mixing, filtration, heating, refrigeration, dehumidification, humidification, ventilation, recovery and sound attenuation. It is available as a horizontally-mounted version for installation indoors or outdoors with a roof and accessories to protect it from the weather. The range is available in a single or dual-flow version.

Thanks to the broad spectrum of solutions on offer, and the product's excellent modularity, the specifications for this product always comply with the EN 13053 and EN 1886 standards, whatever its configuration.

### 39CP L: Tertiary sector applications



- Casing resistance: class D2
- Casing airtightness: class L1 (-400 Pa)/ L2 (+700 Pa)
- Thermal transmission: class T3 (option T2)
- Thermal bridging factor: class TB3 (option TB2)
- Filter bypass: class F9

### 39CP H and 39CP C: Multiple applications



- Casing resistance: class D1
- Casing airtightness: class L1
- Thermal transmission: class T2
- Thermal bridging factor: class TB1
- Filter bypass: class F9

The standard EN-1886, define the main construction features for Air Handling units.

Among most important features we have :

**Thermal transmittance** [W.m<sup>-2</sup>.K<sup>-1</sup>]: The heat flow per area and temperature difference through the casing of the air handling unit.

**Thermal bridging factor** [-]: The ratio between the lowest temperature difference between any point on the external surface and the mean internal air temperature and the mean air-to-air temperature difference

Carrier 39CP range can be upgraded from T3/TB3 to T2/TB2 offering improved technical features and significant energy savings.

## RANGE

The 39CP segment 1 range consists of 9 sizes to handle air flow rates from 1000 to 30,000 m<sup>3</sup>/h.

The diagram below is used to pre-select the required size according to:

- The air velocity in the front active section of the heat exchange coils
- The air flow rate to be handled.

Selection table

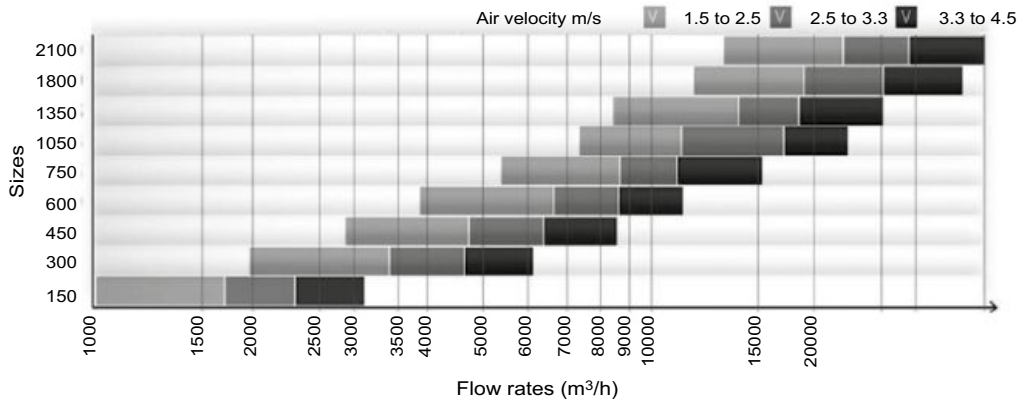

AHU section by sizes (mm)

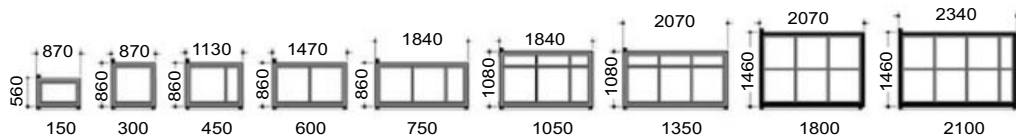

## GENERAL DESCRIPTION OF THE 39CP RANGES

### Casing

- Self-supporting panel construction up to size 2100
- Double-skin panels with 50 mm mineral wool insulation with long fibres with a high insulation coefficient.
- Moulded high strength bi-component polyurethane gaskets for the casing and door, guaranteeing a perfect seal.
- Inside of the AHU is perfectly smooth and even, with no protruding screws, as per the specifications in European standard EN 13053 (no internal handles).
- Doors hung on high quality frames, guaranteeing durability, performance and easy access for maintenance with adjustable hinges, external twist-lock handles and decompression system.
- AHUs delivered in several units are equipped with specific factory-fitted assembly pieces, which ensure perfect alignment to simplify assembly.
- Each component unit of the AHU is equipped with an 80 mm ground insulation frame and multifunction ergonomic supports (handling, assembly).
- Each component is fitted with its own service panels. This allows independent removal for each function.

Standard:

#### 39CP L

- Conventional double-skin panels
- External wall made from sheet metal with RAL 7035 lacquer coating
- Internal wall made from Z275 galvanised steel

#### 39CP H

- Highly-insulated panels, with thermal bridge break profiles
- External wall made from sheet metal with RAL 7035 lacquer coating
- Internal wall made from Z275 galvanised steel

#### 39CP C

- Highly-insulated panels, with thermal bridge break profiles
- External wall made from galvanised steel with RAL 7035 lacquer coating
- Internal wall made from galvanised steel with RAL 7035 lacquer coating

## GENERAL DESCRIPTION OF THE 39CP RANGES

OPTIONS AVAILABLE PER RANGE	39CP L	39CP H	39CP C
Textured RAL 7035 paintwork on external panels	Standard	Standard	Standard
Textured RAL 7035 paintwork on internal panels	X	X	Standard
Internal and/or external panels in 304 L or Z3CN 18.10 stainless steel	NA	X	X
Internal and/or external panels in 316 L or Z3CND 17.11.02 stainless steel	NA	X	X
Stainless steel indoor baseframe	X	X	X
Sloped stainless steel indoor baseframe with drainage	NA	X	X
Galvanised ground insulation frame (h = 80mm)	Standard	Standard	Standard
Painted frame	X	X	X
Stainless steel frame	NA	X	X
Factory-assembled AHU on common rack : max size 1350 or maximum length 6 m	X	X	X
Container kit (for assembled air handling unit)	X	X	X
Adjustable support feet with 60 mm extension	X	X	X
Fixed extension feet up to 400 mm	X	X	X
Sloped roof for outdoor mounting	X	X	X
Louvres with grilles to match external casing finish	X	X	X
Protective cover for external components to match external casing finish	X	X	X
Factory-fitted cable raceway	X	X	X
Lateral technical unit	NA	X	X

X Option

NA Not applicable

### Mixing and air intakes

The air inlet and mixing section may be installed at the intake, inserted between the functions or installed at the device outlet.

These functions are equipped with dampers formed of counter-rotating profiled blades, with lateral gaskets, and driven by conrods.

These dampers are installed outside of or inside the casing, depending on the solution chosen.

Independent control of the louvres: manual, motorised or ready to be motorised

The functions provided depend on the selection:

- Isolation damper
- Two-way mixing with air intake
- Two-way flow distributions: top, front or lateral
- Three-way mixing: aligned, stacked or juxtaposed

Depending on the finishes:

#### 39CP L

- Class 1 galvanised steel blades and frame compliant with EN1751

#### 39CP H / 39CP C

- Class 3 aluminium blades and frame compliant with EN1751

OPTIONS AVAILABLE PER RANGE	39CP L	39CP H	39CP C
Servomotor operated damper	Kit	Kit	Kit
Manual operated damper	X	X	X
Class 3 damper with defrosting system	X	X	X
Class 4 airtightness damper compliant with EN 1751	NA	X	X
Polyester coated face and bypass dampers (frame and blades)	X	X	X
Stainless steel 304L damper	NA	X	X
Stainless steel drain pan	X	X	X
Hinged access door	X <sup>(1)</sup>	X <sup>(1)</sup>	X <sup>(1)</sup>
Lift-off door	X	X <sup>(1)</sup>	X <sup>(1)</sup>
Porthole on door	X	X	X
230V bulkhead light	X	X	X
Door contact switch	NA	X	X

(1) Availability depends on the configuration

X Option

NA Not applicable

## GENERAL DESCRIPTION OF THE 39CP RANGES

### Filters

To meet the requirements of all the applications, a very wide range of filter efficiencies, technologies and dimensions is available.

Across the entire range, and for each type of filter, cells with international dimensions of 24" x 24" and 12" x 24" are available.

On sizes 150 to 1350, compact filters which are 50mm thick are available in full section (FS) to optimise energy consumption.

Different types of filter assembly are available, depending on the efficiency level, technology and location within the AHU.

There are 6 specific assembly systems:

**Assembly A** available for filters with international dimensions and **Assembly A FS** for filters with a full section

- Traditional tracks designed for efficiency levels G1 to M6:  
For Compact cells, 50 mm thick, side door

**Assembly B** available for filters with international dimensions and **Assembly B FS** for filters with a full section

- Compressible tracks designed for efficiency levels G4 to F9 or Activated Carbon (urban pollution) for Compact cells and flexible or rigid bag with side door.

**Assembly C** for filters with international dimensions:

- Universal frames designed for efficiency levels G4 to F9, E10 or Activated Carbon (urban pollution) for Compact cells and flexible or rigid bag with access section and side door

**Assembly D** for Absolute filters with international dimensions

- Absolute large-media frames for EPA and HEPA Absolute cubic cells

**Assembly E** for Absolute filters with international dimensions

- Absolute plate for EPA and HEPA Absolute cubic cells for industrial applications (e.g. pharmaceuticals).

**Assembly F** for Cubic carbon filters with international dimensions

- Large-media frames for Activated Carbon cubic cells.

Description	Construction Code	Assembly	Efficiency (1)	Cell descriptive code
50mm flat metal filter	C	A or C	G1	Galvanised steel metal medium and frame
50mm flat filter	C	A, B or C	G4	Galvanised steel metal frame and synthetic medium
			M5	
			M6	
			F7	
50mm flat filter (full section) up to size 1350	C FS	A FS or B FS	G4	Galvanised steel metal frame and synthetic medium
			M5	
			M6	
			F7	
292mm rigid bag filter	RBHHE	B or C	M6	Polypropylene frame and fibreglass medium
			F7	
			F8	
			F9	
380mm short flexible bag filter	SB	B or C	E10	Galvanised steel metal frame and synthetic medium
			G4	
			M5	
			M6	
600mm long flexible bag filter	LB	B or C	F7	Galvanised steel metal frame and synthetic medium
			F9	
			M6	
292mm Absolute filter	CUBIC 610x610	D or E	E10	Polypropylene frame and fibreglass medium
			H13	
			H14	
292 mm rigid bag carbon filter + fine filter, std universal frame	RBHHE	B or C	Carbon+F7	Polypropylene frame, synthetic + carbon medium
Flexible carbon bag filter + 600mm long bag fine filter	LB	B or C	Carbon + F7	ABS frame, synthetic + carbon medium
292mm rigid bag carbon filter	RBHHE	B or C	Carbon	Carbon polypropylene frame
Cubic carbon filter	CUBIC 595x595	F	Carbon	Metal frame + carbon panel

C : 50 mm compact filter  
 C FS : 50 mm compact filter, full section  
 RBHHE: 290mm rigid bag filter  
 SB : 380mm short flexible bag filter  
 LB : 600 mm long flexible bag filter  
 CUBIC : 292 mm cubic

(1) Carrier 39CP software offers the equivalent classification of the filters according the ISO 16890

## GENERAL DESCRIPTION OF THE 39CP RANGES

OPTIONS AVAILABLE PER RANGE	39CP L	39CP H	39CP C
Lift-off door	Standard	Standard	Standard
Filter pressure tapping	Standard	Standard	Standard
Pressure tapping per filter stage	Standard	Standard	Standard
Additional filter set	X	X	X
Galvanized steel drip tray	X	X	X
Stainless steel drip tray	X	X	X
Liquid manometer (supplied loosely in a kit)	X	X	X
Differential pressure switch	X	X	X
Magnehelic pressure gauge (supplied loosely in a kit)	X	X	X
Double glass porthole	X	X	X
230V bulkhead light (supplied loosely)	X	X	X
230V bulkhead light and wired to external switch	X	X	X
Door contact switch	X	X	X
Filter slide rails painted	X	X	Standard
Filter frame painted	X	X	Standard
304 L or 316 L stainless steel slide rails	X	X	X
Stainless steel frontal access filter frame (fine filters •F")	X	X	X
Painted filter frame (EPA/HEPA filters)	X	X	Standard
Stainless steel filter frame (HEPA filters •H")	X	X	X
Hatch for pressure measurement	NA	X	X

X Option

NA Not applicable

### Plate heat recovery system

Three efficiency levels available: from 60% to 85%

The plate heat exchangers are always equipped with a total bypass on fresh air and access door to the servomotor

Condensate drain pan on exhaust air side, made from galvanised steel with condensate drain piping as standard

Available in a stacked configuration for all sizes

Access door to the condensate drain pan(s)

In the standard construction, the heat exchanger has aluminium plates, and can be used routinely up to an air temperature of 90°C (if the plate heat exchanger is a component of an AHU, the standard limit temperature is 80°C). The leakage flow rate is 0.1%, the nominal flow rate for a pressure difference of 400 Pa between the 2 air streams.

OPTIONS AVAILABLE PER RANGE	39CP L	39CP H	39CP C
Pre-painted aluminium plates	X	X	X
Condensate drain pan (exhaust air side) stainless steel	X	X	X
Condensate drain pan (fresh air side) galvanised	X	X	X
Condensate drain pan (fresh air side) stainless steel	X	X	X
Paint on baffle, partition and support	X	X	X
Plate exchangers components made of 304 L or 316 L stainless steel	NA	X	X
Painted bypass damper	X	X	X
Stainless steel bypass damper	NA	X	X
Servomotor or manual damper operation	X	X	X
Pressure tappings in intake and exhaust	Standard	Standard	Standard
Additional access door	X	X	X
Door inspection window	x	x	x

X Option

NA Not applicable General description of the 39CP ranges



## GENERAL DESCRIPTION OF THE 39CP RANGES

### Rotary heat recovery system

Three efficiency levels available: from 75% to 85%

- Corrugated aluminium fins
- Adjustable peripheral gasket to guarantee a minimum leak flow rate
- Lateral inspection panel

- Constant speed gear motor (230 / 400 V three-phase power supply)
- Maintenance-free ball bearing

OPTIONS AVAILABLE PER RANGE	39CP L	39CP H	39CP C
Gear motor and variable frequency drive for variable speeds from 0 to 10 rpm – 230 V single-phase	X	X	X
Coated aluminium heat recovery wheel	X	X	X
Hygroscopic heat recovery wheel (for humidity exchange)	X	X	X
Enthalpic heat recovery wheel (for total power exchange)	X	X	X
Condensates drain pan	NA	X	X
316 stainless steel drain pan	NA	X	X
Indoor panels polyester coated	NA	X	X
Indoor panels in 304 L or 316 L stainless steel	NA	X	X
Pressure tappings	X	X	X
Purge sector	X	X	X
Door porthole	X	X	X

X Option  
NA Not applicable

### Heating coil

Fluids:

- **Hot water**
  - Construction with copper tubes and aluminium fins.
  - Maximum primary fluid temperature = 120 °C.
  - Operating pressure for water: 8 bar as standard - Higher pressures on consultation.
  - Removable sealing flanges between the casing and manifolds (up to 3" diameter prevent damage to the sealing system during connection operations).

Depending on the type of coil and the diameters required, the manifolds and supply tubes are:

- Copper tubes with unions up to a diam. of 2"1/2.
- Grooved steel tubes for larger diameters.

- **Superheated water**
  - Construction with steel tubes and aluminium fins.
  - Maximum primary fluid temperature = 200 °C.
  - Operating pressure for water: 30 bar max.
  - Supply manifolds and tubes made from steel with smooth ends.
- **Refrigerant**
  - Construction with copper tubes and aluminium fins.
  - Supply tubes made from copper with smooth ends.
- **Steam**
  - Max pressure 2 to 8 bar - stainless steel tubes, aluminium fins.
  - Manifolds and supply tubes are stainless steel tubes with smooth ends

OPTIONS AVAILABLE PER RANGE	39CP L	39CP H	39CP C
Smooth pipe coil (without fins)	X	X	X
Superheated water coil	X	X	X
Steam coil	X	X	X
Condensation coil	X	X	X
Pressure tapping, upstream and downstream	X	X	X
Precoated fins/ max. primary fluid temperature 110°C	X	X	X
Stainless steel water coil	X	X	X
ALTENA treatment, max. temperature 160°C	X	X	X
HERESITE treatment, max. temperature 180°C	X	X	X
Copper fins coil	X	X	X
304 L or 316 L stainless steel tracks	X	X	X
304 L or 316 L stainless steel slide rails	X	X	X
Standard screw flanges	Kit	Kit	Kit
Stainless steel screw flanges	Kit	Kit	Kit
Quick connections kit (copper tubes) (victaulic type)	Kit	Kit	Kit
Threaded connections (steel tubes)	Kit	Kit	Kit
Frost protection thermostat ( manual reset)	X	X	X
Frost protection thermostat with automatic reset (supplied loose item)	X	X	X
Frost protection thermostat with automatic reset (factory fitted)	X	X	X

X Option  
NA Not applicable

## GENERAL DESCRIPTION OF THE 39CP RANGES

### Electric heater

- Shielded resistors in stainless steel scrolled finned tubes
- Connected to copper strips.
- Double insulation assembly.

- Equipped with two safety thermostats: first with manual reset, second with automatic reset.

OPTIONS AVAILABLE PER RANGE	39CP L	39CP H	39CP C
Slide rails painted	X	X	X
304 L or 316 L stainless steel slide rails	X	X	X
304 L or 316 L stainless steel coil casing	X	X	X
Single- or three-phase connection	X	X	X

X Option

NA Not applicable

### Cooling coil

- Chilled water / direct expansion coil
- Construction with copper tubes and aluminium fins.
- Operating pressure for water: 8 bar as standard - Higher pressures on consultation.
- Inclined condensate drain pan with drain pipes to be connected to a siphon on site.
- Droplet separator as standard if necessary, as an option on request.
- Removable sealing flanges between the casing and manifolds up to 3" diameter, preventing damage to the sealing system during connection operations.

Depending on the type of coil and the diameters required, the manifolds and supply tubes are:

- Copper tubes with unions up to a diam. of 2"1/2.
- Grooved steel tubes for larger diameters.
- Direct expansion evaporation
  - Construction with copper tubes and aluminium fins.
  - Inclined condensate drain pan with drain pipes to be connected to a siphon on site.
  - Droplet separator as standard if necessary, as an option on request.
  - Standard smooth copper refrigerant supply tubes (supplied capped)
  - Manifold on fluid intake as standard.

OPTIONS AVAILABLE PER RANGE	39CP L	39CP H	39CP C
Chilled water coil	X	X	X
Direct expansion evaporation coil	X	X	X
Access panel on droplet separator	as standard if compulsory		
Precoated fins/ max. primary fluid temperature 110°C	X	X	X
Stainless steel tubes coil	X	X	X
Copper fins coil	X	X	X
ALTENA treatment, max. temperature 160°C	X	X	X
HERESITE treatment, max. temperature 180°C	X	X	X
Slide rails painted	X	X	X
Stainless steel slide rails	X	X	X
304 L or 316 L stainless steel coil casing	X	X	X
316 L stainless steel condensate drain pan	X	X	X
316L stainless steel hygienic drain pan	NA	X	X
Insulated drain pan (cell foam)	X	X	X
Headers/elbows insulation	X	X	X
All stainless steel droplet separator (frame and medium)	X	X	X
Polypropylene blade droplet separator, galvanised frame	X	X	X
Polypropylene blade droplet separator, stainless steel frame	NA	X	X
Aluminium blade droplet separator, galvanised frame	NA	X	X
Aluminium blade droplet separator, stainless steel frame	NA	X	X
Pressure tapping, upstream and downstream	X	X	X
Standard screw flanges	Kit	Kit	Kit
Stainless steel screw flanges	Kit	Kit	Kit
Tubes with quick connections (copper tubes) (victaulic type)	Kit	Kit	Kit
Threaded connections (steel tubes)	Kit	Kit	Kit
Frost protection sensor support	X	X	X

X Option

NA Not applicable

## GENERAL DESCRIPTION OF THE 39CP RANGES

### Fans

- Forward-curved dual-inlet fan.
- Backward-curved dual-inlet fan.  
Steel scroll and impeller.  
Belt and pulley transmission on the dual-inlet fans.  
Assembly on anti-vibration frame with flexible internal sleeve and damper mounts.
- Metal impeller plug fan turbine with AC motor  
Assembly on anti-vibration frame with flexible internal sleeve and damper mounts.
- Standard motor: asynchronous three-phase, 230 / 400 V - 50 Hz up to 3 kW - 400 V - 50 Hz from 4 kW, IP 55 protection, class F with PTC
- Steel plug fan with EC motor with integrated variator, three-phase 400 V n- 50 Hz
- Inspection hatch with bolts in compliance with the "MECHANICAL SAFETY" specification in the EN 1886 standard and the machinery directive.

OPTIONS AVAILABLE PER RANGE	39CP L	39CP H	39CP C
Forward curved centrifugal fan with pulley belt transmission	X	X	X
Backward curved centrifugal fan with pulley belt transmission	X	X	X
Plug fan with asynchronous motor	X	X	X
EC plug fan	X	X	X
Flush mounted panel	X	X	X
Access panel mounted on hinges	Standard	Standard	Standard
Pressure tappings	X	X	X
Door contact switch	X	X	X
Panel window	X	X	X
Smoke detector (NF S61961)	X	X	X
230V Bulkhead light (supplied loose item)	X	X	X
230V Bulkhead light fitted and wired to an external switch	X	X	X
Anticorrosion painting for wheel and motor assembly (centrifugal and AC plug fan motor)	X	X	X
Stainless steel wheel and motor assembly (centrifugal and AC motor plug fan)	NA	X	X
Anticorrosion painting for EC fan wheel	NA	X	X
Protection grill for centrifugal fan	X	X	X
Screened door protection	X	X	X
Housing for belt - pulley transmission	X	X	X
2 motors set in parallel	X	X	X
Motor support on rails	X	X	X
Variable frequency drive (supplied loose item)	X	X	X
Variable frequency drive factory fitted	X	X	X
Door switch factory fitted	X	X	X
Door switch ( supplied loose item)	X	X	X
Anti recirculation damper for fan	X	X	X

X Option  
NA Not applicable

### Sound attenuator

- Different lengths of baffle depending on the required attenuation.
- Mineral wool of different densities, the faces are covered with an anti-erosion shield.
- Galvanised panels.

OPTIONS AVAILABLE PER RANGE	39CP L	39CP H	39CP C
Baffle lengths (in mm)	600 - 900 - 1200 - 1500		
Anti schredding glass cloth	NA	X	X
Polyester coated slide rails	X	X	X
Epoxy painted sheet metal baffles	X	X	X
304 L or 316 L stainless steel rails	X	X	X

X Option  
NA Not applicable

## GENERAL DESCRIPTION OF THE 39CP RANGES

### Standalone production steam humidifier

With steam production (standalone with electrodes)

The supply includes

- Aluminium steam distributor.
- Steamer with electrical cabinet and controller (IP20).
- Proportional or on/off control.

- Duct/cylinder connection.

- Condensate return tubes and connections.
- Three-phase 400 V - 415 V supply voltage depending on capacity
- Min and max supply water conductivity limits 125 - 1250 microsiemens/cm (8000 - 800 ohm).
- Hardness of supply water 15 - 30 degrees (French).

OPTIONS AVAILABLE PER RANGE	39CP L	39CP H	39CP C
Stainless steel	X	X	X
Galvanised droplet separator	X	X	X
Stainless steel droplet separator	X	X	X
Double glass porthole	X	X	X
230V Bulkhead light factory fitted and wired to an external switch	X	X	X
Flush mounted panel	X	X	X
Door contact switch	X	X	X

X Option

NA Not applicable

### Control

The electrical box is integrated into the unit and the electrical cables are protected by an enclosed cable raceway, factory-fitted.

The unit can be supplied as a single unit, equipped with a control which is fully assembled and tested in the factory if it is formed of one block, or a multi-block assembled on the optional multi-block frame.

Plug & Play solution: the electrics box is powered by a 400 V + earth power supply

The control software for the 39CP range enables the following:

- Temperature regulation\*: sensor on supply air / return air / room air
- Humidification and dehumidification regulation\*: sensor on return or room air
- Fan management: constant flow / constant pressure
- Filter fouling management (4-stage filtration as maximum)
- Single-zone air quality management (CO<sub>2</sub>) sensor on return air or room air
- Water coils: cooling/heating/mixed/direct expansion (3 maximum)
  - 2-way valve
  - Three-way valve.

- Electric heater (4-stage heaters as maximum)

- Proportional and On/Off control
- 1 TRIAC type proportional stage (compulsory)
- Independent power supply, control by the AHU PLC.

- Steam humidifier with electrode:

- Independent power supply, control by the AHU PLC.
- Management of cooling modes: Free cooling / Night cooling

- Management of frost protection faults

- Fire protection

- Communication board available:

- Modbus RTU RS485 / Modbus TCP IP / KNX / BACNET IP

The control does not enable the following elements to be managed:

- Steam coil / Superheated water coil / Glycol/water mix coils / Condenser coil
- Make-up / gas burner
- Adiabatic humidifier

\* availability depends on options; see specific control document

### Extra accessories:

OPTIONS AVAILABLE PER RANGE	39CP L	39CP H	39CP C
Flexible sleeves	X	X	X
Insulated flexible sleeves for the outside of the casing	X	X	X
Rain protection hood (supplied with grill)	X	X	X
Additional protection grill	X	X	X
Factory-assembled AHU on common rack : max size 1350 or maximum length 6 m	X	X	X

X Option

NA Not applicable

## DIMENSIONS

### External dimensions and raceway details\*

\* Raceway optional

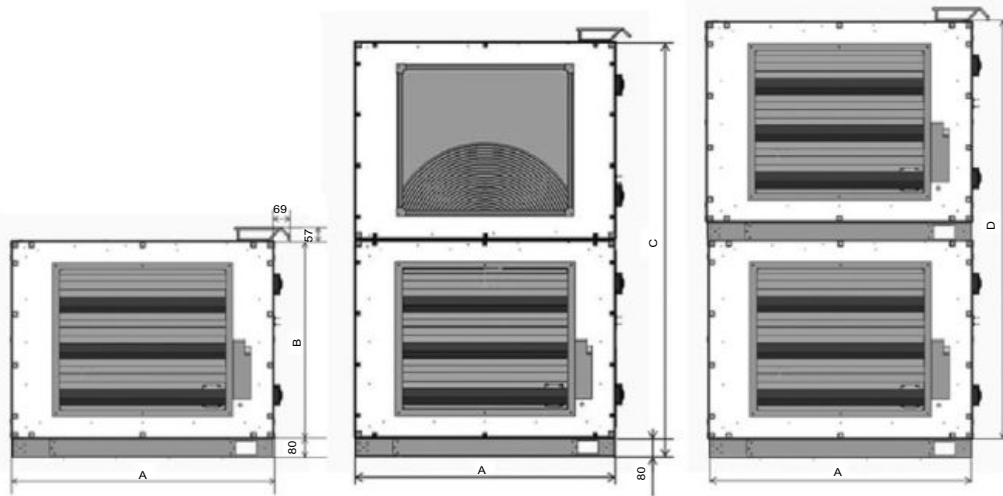

Sizes	Casing external dimension				Block length <sup>(1)</sup>
	A	B	C	D	
150	870	560	1122		250 < L < 2800
300	870	860	1722		250 < L < 2800
450	1130	860	1722		250 < L < 2800
600	1470	860	1722		250 < L < 2800
750	1840	860	1722		250 < L < 2800
1050	1840	1080	2162		250 < L < 2800
1350	2070	1080	2162		250 < L < 2800
1800	2070	1460		3000	250 < L < 2800
2100	2340	1460		3000	250 < L < 2300

(1) Length excluding the unit end panel

### Connection flanges

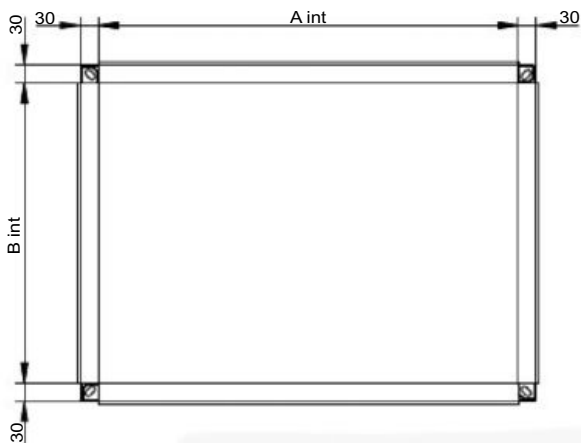

- Reference 00: Lateral air intake
- Reference 1: Air intake, small section
- Reference 2: Air intake, large section
- Reference 3: Scroll fan discharge air intake

		150	300	450	600	750	1050	1350	1800	2100
39CP L										
39CP H										
39CP C										
Reference 00 - LATERAL	A	320	320	470	620	720	770	970	870	970
	B	370	670	670	670	670	870	870	1270	1270
Reference 1 - SMALL SECTION	A	515	515	775	1115	1485	1485	1715	1715	1985
	B	220	370	370	370	370	470	470	670	670
Reference 2 - LARGE SECTION	A	515	515	775	1115	1485	1485	1715	1715	1985
	B	370	670	670	670	670	870	870	1270	1270
Reference 3: FAN DISCHARGE	A	-	520	520	520	520	620	620	920	920
	B	-	520	520	520	520	620	620	920	920



## DIMENSIONS

**SIDE-BY-SIDE CONFIGURATION** is available for 39 CP L , 39CP H ,39 CP C in sizes 1800 and 2100.

This configuration is available in **T2/TB2 39CP configurations** and **with PLATES HEAT EXCHANGER** heat recovery.

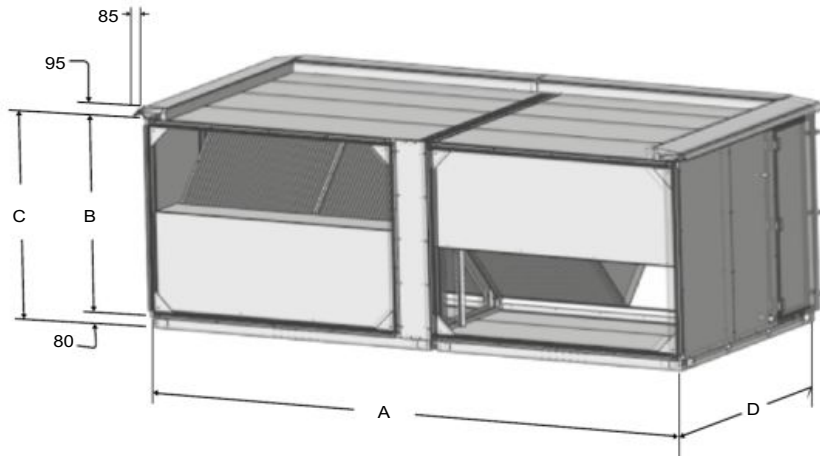

Sizes	Casing external dimension			
	A	B	C	D <sup>(1)</sup>
60	4390	1460	1540	2000
70	4930	1460	1540	2000

(1) Length excluding the 23 mm unit end panel at each end

This configuration is useful for indoor and outdoor installations , as it has reduced dimensions, that makes it ideal for refurbishment jobs and also for outdoor installation as it can be easily hidden by an aesthetical structure.

Component's accessibility is improved, and weight / load distribution is more equilibrated, which makes easier for transport and maintenance operations.



## AIR HANDLING UNIT



# 39CZ

Air flow: 25000 to 60000 m<sup>3</sup>/h

The 39CZ range is designed for the service sector, industry and healthcare markets, to meet different requirements in terms of air mixing, filtration, heating, refrigeration, dehumidification, humidification, ventilation, recovery and sound attenuation. It is available as a horizontally-mounted version for installation indoors or outdoors with a roof and protection accessories. The range is available in a single or dual-flow version.

Thanks to the broad spectrum of solutions on offer, and the product's excellent modularity, the specifications for this product will always comply with the EN 13053 and EN 1886 standards, whatever its configuration.

AHU for all applications

Designed to meet the EN 13053 and EN 1886 standards

The effective solution for service sector, industry and healthcare applications



CARRIER participates in the ECP programme for 39CZ range Check ongoing validity of certificate: [www.eurovent-certification.com](http://www.eurovent-certification.com)

## USE

External wall with RAL 7035 paint

Compliance with the provisions of the EN 13053 standard

Classification in accordance with European standard EN 1886

Casing resistance: class D1

Casing airtightness: class L1

Filter bypass leak: class F9

Thermal transmittance: class T2

Thermal bridge factor: class TB2

## RANGE

The 39CZ range consists of 4 sizes to handle air flow rates from 25000 to 60000 m<sup>3</sup>/h.

The diagram below shows how to preselect the necessary size based on:

- The flow speed in the active front section of the exchanger coils.
- The air flow rate to be handled.



## RANGE

The diagrams show the standard compositions with the usage limit corresponding to the components.

- Air heater (A).
- Air conditioning unit without droplet separator (b).
- With drain screen separator (C).
- With blade-type separator (D)

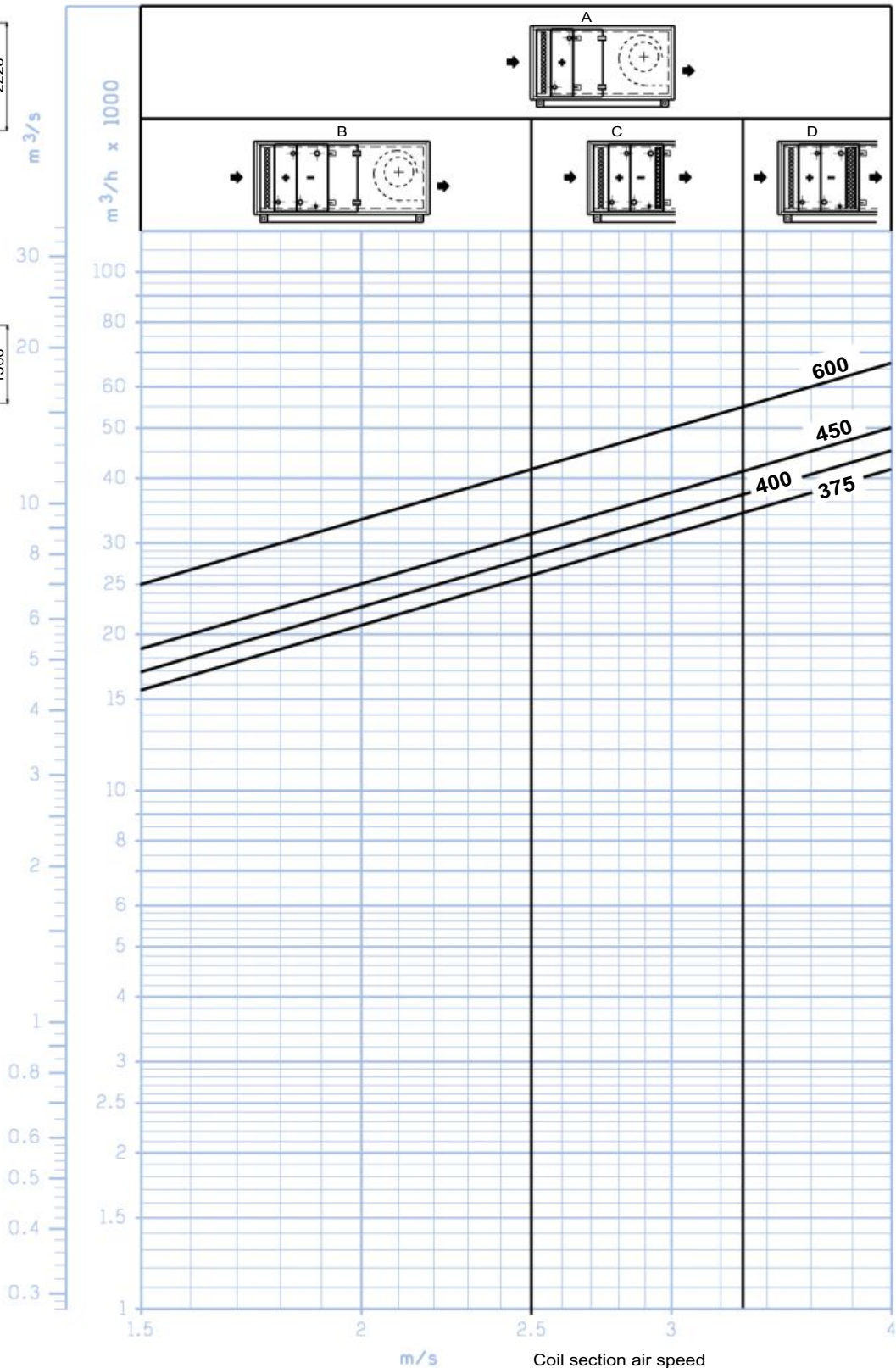
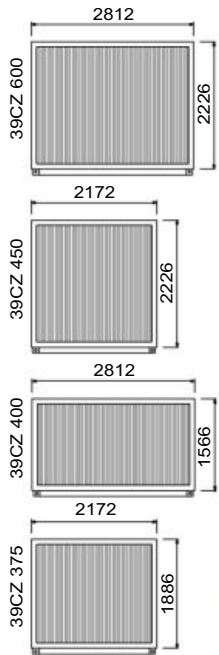

## DESCRIPTION

### Casing

- Double-skin panel with 50 mm mineral insulation with long fibres reinforced by welded fibreglass material,
- Peripheral frame fitted or mounting brackets in stainless steel,
- Depending on the size, double-skin panels, galvanised, coated, smooth walls with no protruding screws as per EN 13053.

Construction structure depending on AHU sizes.

- Sizes 100 to 150: panels screwed onto an aluminium structure sunk into the casing.
- Sizes 200 to 600: panels screwed onto an aluminium double honeycomb structure offering high resistance to flexing.

- Air handling units consist of multi-block components or mono-block components if the composition and size allow.
- All of our blocks can be disassembled on the installation site.

At least one removable panel per function in accordance with EN 13053, access panel as standard on functions requiring maintenance.

Lift-off panels on offset hinges, equipped with slow closing latches in composite material, polyamide handles, large section square porthole in accordance with EN 13053.

OPTIONS AVAILABLE PER RANGE	39CZ ST	39CZ CL & HE
Adjustable support feet + 35/+ 60 mm	X	X
Support feet risers up to 400 mm	X	X
Stainless steel ground insulation casing (h: 100)	X	X
Epoxy or polyurethane paint on int. and ext. panels	X	X
Int. and ext. panels in pre-painted RAL 9010 sheet metal		standard
Int. and ext. panels in 304 L stainless steel or Z3CN 18.10	X	X
Flat stainless steel base	X	X
Inclined stainless steel base (per block)	X	X
Reinforced insulation	X	X
Roof for OUTDOOR model	X	X
Screened canopies for OUTDOOR model	X	X

### Damper

- Isolation damper
- Safety damper (CH38)
- Control damper

All the dampers consist of airfoil blades, counter rotating with lateral seals and driven by toothed wheels or control rods. Steel frame and aluminium blades on 39CZ ST CL & HE Class 3 in accordance with EN1751. These dampers are installed on the inside or outside of the casing, depending on the solution chosen. Louvre control: manual, motorised or to be motorised.

OPTIONS AVAILABLE PER RANGE	39 CZ ST	39 CZ CL & HE
Servomotor	kit	kit
Mechanism electric heaters <-25°C	X	X
Toothed wheels	standard	standard
Control rods	X	X
Class 4 sealing in accordance with EN 1751		X
Polyurethane frame paint	X	standard
Polyurethane or epoxy paint on louvres and frames	X	X
Frame and dampers in stainless steel sheet		X



## DESCRIPTION

### Boxes

#### Air intake boxes (AHU intake)

Single air intake, mixing, economiser mixing.

#### Air discharge box (AHU discharge)

Directional, distribution.

Assembly of combined louvres outside or inside the casing for the task defined by the section chosen. Manual control, motorised or to be motorised.

OPTIONS AVAILABLE PER RANGE	39 CZ ST	39 CZ CL&HE
Servomotor	kit	kit
Mechanism electric heaters for fresh air at a temperature < -25°C	X	X
Toothed wheels	standard	standard
Control rods	X	X
Class 4 sealing in accordance with EN 1751		X
Galvanised safety base with drain	X	X
Stainless steel sheet safety base with drain	X	X
Polyurethane or epoxy paint on louvres and frames	X	X
Lighting not connected (if access provided)	kit	kit
Lighting wired to switch (if access provided)	X	X
Double glass porthole	X	X
Lift-off panel (louvre control on opposite side)	X	X
Hinged door (louvre control on opposite side)	X	X

### Filters

- G2 & G4 efficiency, M5 to F9, H10 to H14 (with the equivalence of the new ISO 16890 filtration standard) or activated carbon with international dimensions mounted on compressible tracks, on universal frame or large-media frames with pressure tapings on each filtration stage, EN 1886 Filter bypass leakage classification (F9 classification).
- Fitting system equipment for filter cells for all 3 ranges.

#### ■ 4 Standardised assembly systems

**Assembly 0:** traditional tracks for full section G4 cells.

**Assembly 1:** compressible tracks (horizontal extension), G2 and G4 efficiency, 65 to 90 % gravimetric (GRAVI) efficiency with side door.

**Assembly 2:** compressible tracks (horizontal and vertical extension), M5 to F9 efficiency, 40 to 98 % opacimetric (OPA) efficiency with side door.

- Filter cells with international dimensions 24" x 24" and 12" x 24".
- Efficiency classification in accordance with EN 779 from G2 to F9.
- Efficiency classification in accordance with EN 1822 from H10 to H14.

**Assembly 3:** 3U universal frames or 3B large-media frames, M5 to H10 efficiency for universal frames, 40 % OPA to 85 % MPPS efficiency, H10 to H14 efficiency for large-media frames, 85 to 99.995 % MPPS efficiency.

**Activated carbon:** a model with activated carbon cells for urban pollution can also be installed in assembly 2 or 3 (universal frame); another for specific pollution must be installed in a large-media frame.

## DESCRIPTION

OPTIONS AVAILABLE PER RANGE	39 CZ ST	39 CZ CL & HE
Lift-off panel or hinged door	X	X
Galvanised safety container	X	X
Stainless steel safety container		X
Pressure tapping per filter stage	standard	standard
Liquid pressure gauge	kit	kit
Contact pressure gauge	kit	kit
Magnehelic pressure gauge	kit or assembled	kit or assembled
Double glass porthole	X	X
Lighting not connected	kit	kit
Lighting wired to switch	X	X
Door contact	kit or assembled	assembled
Polyurethane or epoxy paint on tracks and frames	X	X
Paint on frame:	X	standard
polyurethane	X	
Stainless steel tracks	X	standard
Stainless steel universal frame (•F" fine filters)	X	X
Stainless steel large-media frame (HEPA •H" filters)	X	X
Pressurised door (assembly 3 downstream of the fan)	standard	standard
Opening for DOP injection/Hatch for DOP measurement		X

## DESCRIPTION

### Heating coil

- For hot water
  - Construction with copper tubes and aluminium fins.
  - Maximum primary fluid temperature = 120 °C.
  - Operating pressure for water: 8 bar as standard - Higher pressures on consultation.

Depending on the type of coil and the diameters required, the manifolds and supply tubes are:

- Copper or steel tubes with unions up to 3" diameter.
  - Steel tubes with smooth ends for larger diameters.
  - Removable sealing flanges between the casing and manifolds (up to 3" diameter prevent damage to the sealing system during connection operations).
- For superheated water
    - Construction with steel tubes and aluminium fins.
    - Maximum primary fluid temperature = 200 °C.
    - Operating pressure for water: 30 bar max.
    - Supply manifolds and tubes made from steel with smooth ends.

- For refrigerant fluid
  - Construction with steel tubes and aluminium fins.
  - Supply tubes made from copper with smooth ends.
- For steam (on consultation)
  - Low pressure < 2 bar - copper tubes, aluminium fins.
  - High pressure 2 to 8 bar - cupronickel or stainless steel tubes depending on the size of the AHU, the pressure and the steam quality.
  - Supply manifolds and tubes made from steel or stainless steel with smooth ends.

OPTIONS AVAILABLE PER RANGE	39 CZ ST	39 CZ CL & HE
Hot water coil in stock	X	X
Standard circuit coil	X	X
Superheated water coil	X	X
Steam coil	X	X
Condensation coil	X	X
Antifreeze probe slide	X	X
Frost protection thermostat supplied in a kit	X	X
Frost protection thermostat supplied mounted	X	X
Pressure tapplings, upstream and downstream	X	X
Precoated fins/primary fluid max. T° 110°C	X	X
Coil with ALTENA treatment max. T° 160°C	X	X
Coil with HERESITE treatment max. T° 180°C	X	X
Copper fins	X	X
Galvanised steel safety container	X	X
Stainless steel safety container	X	X
Epoxy paint on tracks	X	standard
Stainless steel tracks	X	X
Stainless steel coil panels	X	X
Screw flanges and counter-flanges	kit	kit
Tubes with quick connections	X	X

### Electric heater

- Shielded resistors in scrolled stainless steel finned tubes
- Connection to copper strips.
- Double insulation assembly.
- Safety thermostat with automatic and manual reset as standard.

- To commission the heater: refer to the manual supplied with each unit.
- Take the necessary precautions to prevent abnormal heating when the fan is switched off (ensure post ventilation).

OPTIONS AVAILABLE PER RANGE	39 CZ ST	39 CZ CL & HE
Safety thermostat with automatic reset	standard	standard
Three-phase or single-phase connection	X	X
Painted tracks	X	standard
Stainless steel tracks	X	X
Stainless steel heater panels	X	X

## DESCRIPTION

### Cooling coil

Inclined condensate drain pan in accordance with EN 13053,

- Chilled water
  - Construction with copper tubes and aluminium fins.
  - Operating pressure for water: 8 bar as standard - Higher pressures on consultation.
  - Inclined condensate drain pan with drain pipes to be connected to a siphon on site.
  - Droplet separator as standard if necessary, as an option on request.

Depending on the type of coil and the diameters required, the manifolds and supply tubes are:

- Copper or steel tubes with unions up to 3" diameter.
- Steel tubes with smooth ends for larger diameters.
- Removable sealing flanges between the casing and manifolds up to 3" diameter prevent damage to the sealing system during connection operations.

- Direct expansion evaporation
  - Construction with copper tubes and aluminium fins.
  - Inclined condensate drain pan with drain pipes to be connected to a siphon on site.
  - Droplet separator as standard if necessary, as an option on request.
  - Standard smooth copper refrigerant supply tubes (supplied capped)
  - Manifold on fluid intake as standard.
  - Removable panel for accessing the expansion valve and solenoid valve incorporated in the casing (the valve and solenoid valve may be supplied assembled if the coil is connected to a CARRIER condensation unit).

OPTIONS AVAILABLE PER RANGE	39 CZ ST	39 CZ CL & HE
Chilled water coil in stock	X	X
Standard circuit chilled water coil	X	X
Direct expansion evaporation coil	X	X
Access panel on droplet separator	as standard if compulsory	
Pressure tapings, upstream and downstream	X	X
Precoated fins	X	X
Coil with ALTENA treatment	X	X
Coil with HERESITE treatment	X	X
Copper fins	X	X
Stainless tube exchanger, aluminium fins	X	X
Stainless steel condensate drain pan	X	standard
Heat insulation of pan, elbows and manifolds	X	X
Painted tracks	X	standard
Stainless steel tracks	X	X
Hygiene pan		X standard on HE
Stainless steel heater panels	X	X
Fully galvanised droplet separator	as standard if compulsory	
Droplet separator with galvanised frame, stainless steel medium	X	X
100% stainless steel droplet separator, frame and medium	X	as standard if compulsory
Droplet separator with polypropylene blades	as standard if compulsory	
Screw flanges and counter-flanges	kit	kit
Tubes with quick connections	X	X

## DESCRIPTION

### Adiabatic humidifiers

- Spray - Efficiency 80 to 90%
  - Stainless steel module with sloped bottom, door for inspection, maintenance and replacement of the drain screens and droplet separator.
  - 2 or 3 spray ramps (depending on efficiency).
  - Drain screens.
  - Water tank with its supply equipment.

OPTIONS AVAILABLE PER RANGE	39 CZ ST	39 CZ CL & HE
400 V three-phase pump and recirculation accessories	X	X
Double glass porthole	X	standard
Lighting not connected	kit	kit
Lighting connected on switch	X	X
Droplet separator with galvanised frame with stainless steel mesh	X	standard
Fully stainless steel droplet separator	X	X
Water tank pan spray washer	X	X
Hydraulic connection for UV treatment of recirculated water	X	X

### Steam humidifiers

- Without steam production
 

The supply includes:

  - Stainless steel steam distributor
  - Permissible steam pressure range (0.2 to 3.5 bar)
  - Cast iron steam/water separator
  - Main steam valve
  - 24 V or 240 V on/off or progressive servomotor

OPTIONS AVAILABLE PER RANGE	39 CZ ST	39 CZ CL & HE
Galvanised steel safety container	X	X
Stainless steel safety container	X	X
Fully galvanised droplet separator	X	X
Droplet separator with galvanised frame, stainless steel mesh	X	X
Fully stainless steel droplet separator	X	X
Double glass porthole	X	X
Lighting not connected	kit	kit
Lighting connected on switch	X	X
Lift-off panel	X	X

- With steam production (standalone with electrodes)
 

The supply includes:

  - Aluminium steam distributor.
  - Steamer with electrical cabinet and controller (IP 20).
  - Proportional or on/off control.
  - Humidity controller or control sensor.
  - Duct/cylinder connection.
  - Condensate return tubes and connections.
  - 230 V single-phase or 400 V - 415 V three-phase supply voltage.
  - Min and max supply water conductivity limits 125 - 1250 microsiemens/cm (8000 - 800 ohm).
  - Hardness of supply water 15 - 30 degrees (French).

OPTIONS AVAILABLE PER RANGE	39 CZ ST	39 CZ CL & HE
Galvanised safety container	X	X
Stainless steel safety container	X	X
Fully galvanised droplet separator	X	X
Droplet separator with galvanised frame, stainless steel mesh	X	X
Fully stainless steel droplet separator	X	X
Double glass porthole	X	standard
Lighting not connected	kit	kit
Lighting connected on switch	X	standard
Lift-off panel	X	X

- With steam production (standalone with heaters) on consultation



## DESCRIPTION

### Fans

- Forward-curved dual-inlet fan.
- Backward-curved dual-inlet fan.
- Plug fan.
- EC plug fan.
- Steel scroll and impeller.
- Assembly on anti-vibration frame.
- Connection via internal flexible sleeve.
- Ball bearings mounted in fan inlets.
- Belt and pulley transmission on the dual-inlet fans.
- Standard motor: asynchronous three-phase, 230 / 400 V - 50 Hz up to 4 kW - 400 V - 50 Hz from 5.5 kW, IP 55 protection, class F with PTC.

OPTIONS AVAILABLE PER RANGE	39 CZ ST	39 CZ CL & HE
Fan with forward-curved blades and transmission	X	X
Fan with backward-curved blades and transmission	X	X
Plug fan	X	standard
EC plug fan	X	X
Sparkproof fan	X	X
Spring mounts	standard	standard
Lift-off panel	X	X
Hinged door	standard	standard
Pressurised door (plug fan), hinged for sizes > 250	standard	standard
Pressure connections	X	X
Holes with blanking covers	X	X
Door contact	kit or assembled	kit or assembled
Galvanised steel safety container	X	X
Stainless steel safety container	X	X
Double glass porthole	X	X
Smoke detector (NF S61961)	kit	kit
Lighting not connected	kit	kit
Lighting connected on switch	X	X
Paint on casing and bracket	X	standard
Stainless steel casing, bracket	X	X
Inspection hatch and vent on scroll	X	X
Epoxy painted scroll and impeller	X	standard
Screens on inlets	X	X
Door protection	X	X
Belt housing	X	X
2 motors fitted	X	X

### Heat recovery unit

- Plate
  - Standard construction or HEE plate heat exchanger.
  - The heat exchanger has aluminium plates. This component can be used normally up to an air temperature of 150 °C (if the plate heat exchanger is an AHU component, the standard temperature limit is 80 °C with a differential pressure of 1000 Pa and a leak flow rate between the 2 air streams (EXHAUST/INTAKE) of less than 1 %.
  - Condensate drain pan on exhaust air side, made from galvanised steel with condensate drain piping as standard.

OPTIONS AVAILABLE PER RANGE	39 CZ ST	39 CZ CL & HE
For stacked AHUs	X	X
For side by side AHUs	X	X
G4 prefilter and M5 filter incorporated depending on size	X	X
Bypass on fresh air	X	X
Coated aluminium plates	X	X
Epoxy paint on internal panels	X	X
Pressure tapping on the 4 air handling orifices	X	X
Stainless steel condensate drain pan	X	X
Damper control, manual, motorised or ready to be motorised	X	X

## DESCRIPTION

### ■ Rotating

- Corrugated aluminium exchange medium.
- Adjustable midway and peripheral gasket to guarantee a minimum leak flow rate.
- Lateral inspection panel.

- Constant speed gear motor (230/400 V three-phase power supply).
- Maintenance-free ball bearing.
- For sensible power exchange as standard.

OPTIONS AVAILABLE PER RANGE	39 CZ ST	39 CZ CL & HE
Gear motor and variable frequency drive for variable speeds from 0 to 10 rpm – 230 V single-phase	X	X
Coated aluminium rotor	X	X
Hygroscopic rotor for total power exchange	X	X
Polyurethane or epoxy painted internal panels	X	X
Stainless steel internal panels	X	X
Pressure tapping on the 4 air handling orifices	X	X

### Sound attenuators

- Baffles.
- Mineral wool of different densities, the faces are covered with an anti-erosion shield.
- Galvanised panels.

OPTIONS AVAILABLE PER RANGE	39 CZ ST	39 CZ CL & HE
Baffle length	500 - 900 - 1200 - 1500	
Coating with fray-resistant fabric	X	standard
Painted mounting tracks	X	standard
Painted baffle panels	X	standard
Stainless steel baffle panels	X	X

### Accessories

OPTIONS AVAILABLE PER RANGE	39 CZ ST	39 CZ CL & HE
Standard flexible sleeves for the outside of the casing	X	X
Insulated flexible sleeves for the outside of the casing	X	X
Rain protection frame with bird screen	X	X
Grille frame for protection of the air handling orifices on AHUs	X	X

## BLOCK AND AHU DIMENSIONS

Table of "L" block lengths available (all integrated elements), the total length of the AHUs is obtained by adding 25 mm to each end.

		Unit No.	350 & 450	400 & 600
Block/AHU maximum length	Length "L"	L2		200
		L3		300
		L4		400
		L5		500
		L6		600
		L7		700
		L8		800
		L9		900
		L10		1000
		L11		1100
		L12		1200
		L13		1300
		L14		1400
		L15		1500
		L16		1600
		L17		1700
		L18		1800
		L19		1900
		L20		2000
		L21		2100
		400 & 600		L23
350 & 450		L32	3200	

■ AHU dimensions

- L length of integrated elements
- Le 1 length of integrated elements + 1 end panel
- Le 2 length of integrated elements + 2 end panels

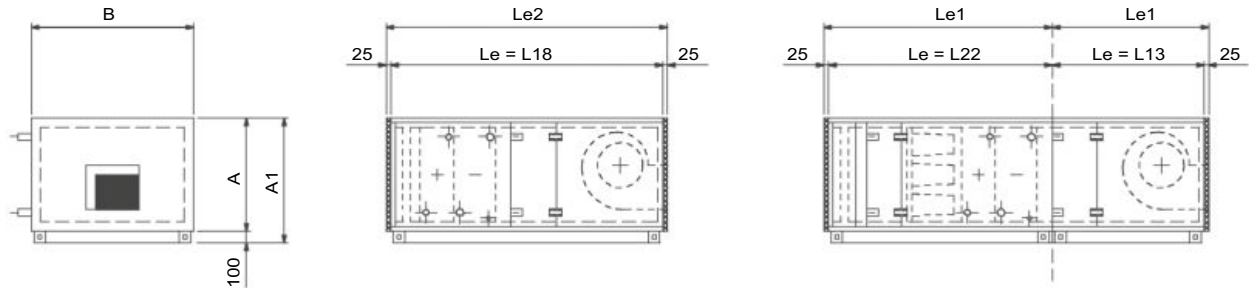

Unit No.	375	400	450	600
A	1886	1566	2226	2226
A1	1986	1666	2326	2326
B	2172	2812	2172	2812

## BLOCK AND AHU DIMENSIONS

■ Connection flanges

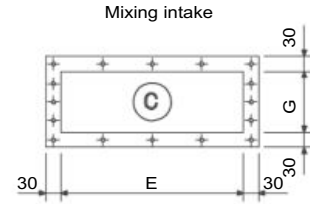
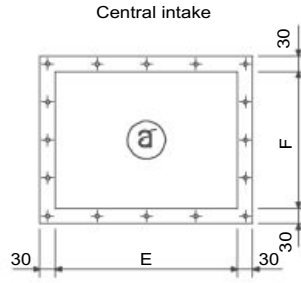
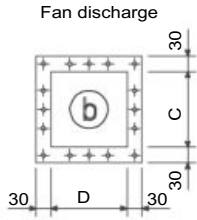

Unit No.	375	400	450	600
C	1024	914	1144	1144
D	1024	914	1144	1144
E	1860	2510	1860	2510
F	1510	1310	1810	1810
G	760	610	910	910





## AIR HANDLING UNITS



# 39HQ

Air flow 5000-130000 m<sup>3</sup>/h

Airovision is a modular construction that can be fully customised to provide the required performance for any application.

Special new casings encompass only high-quality components, including filters, heat recovery systems, fan assemblies, cooling and heating coils, humidifiers and attenuators.

The Airovision range also pays special attention to air quality and reduction of the energy required to cool, heat, humidify and supply the conditioned air.

Airovision is available in a large selection of sizes and arrangements, suitable for many different applications.



**Controls (Option)**



[www.eurovent-certification.com](http://www.eurovent-certification.com)

## OPTIONS

- 100% stainless steel
- Direct-drive fans
- All types of humidification systems, including infrasonic
- Flat pack option for site assembly
- Heat recovery systems (run-around coil, plate heat exchanger and thermal wheels)
- Wide selection of standard accessories
- 316L stainless steel drain pan with PVC wall lining in the outside air inlet section and filter section
- Plug fan EC motors
- Pro-Dialog controller with human interface (local or remote installation)

## FEATURES AND ADVANTAGES

- Airovision is a modular construction that can be fully customised to provide the required performance for any application.
- Special new casings encompass only high-quality components, including filters, heat recovery systems, fan assemblies, cooling and heating coils, humidifiers and attenuators.
- The Airovision range also pays special attention to air quality and reduction of the energy required to cool, heat, humidify and supply the conditioned air.
- Airovision is available in a large selection of sizes and arrangements, suitable for many different applications.
- Applications include leisure and event complexes, theatres, museums, libraries, offices in companies and government institutions, shopping centers, super-markets, department stores and educational establishments, as well as oil drilling rigs, airports and cruise ships.
- In addition Airovision is also ideal in health care and in industries with stringent hygiene requirements.

### Environmentally sound

- No paint treatment required after the production process
- 100% recyclable components
- Low energy usage due to optimised component selection
- High-efficiency heat recovery systems available

### Technical specification (in accordance with EN1886)

- Heat transfer factor class T2
- Thermal bridging factor TB 2
- Air tightness class B (L2)
- Mechanical strength class 1A (DI)
- Filter bypass leakage
  - class F7 for standard slide-in construction
  - class F9 for special slide-in construction
  - class F9 for built-in construction

### High-efficiency centrifugal fan



### Special sorption heat recovery wheels



### Filters are easily removable



### Generously sized access doors



## FEATURES AND ADVANTAGES

### Rigid construction

- 1 Carrier profiled steel frame construction with purpose-built corner and center posts
- 2 Panels with 60 mm thick thermal insulation
- 3 Robust base frame made of galvanised steel box profile

### High corrosion resistance

- 4 316L stainless steel drain pan with PVC wall lining in the outside air inlet section and filter section (option)
- 5 Filters held in 316L stainless steel frames
- 6 Anti-corrosion protection available
- 7 Internal and external panels made of high-quality prepainted galvanised sheet steel
- 8 Cooling coils with integrated stainless steel drain pan and plastic droplet eliminator housed in an aluminium frame
- 9 Special panel design and frame detail eliminate the risk of condensation forming in the panels

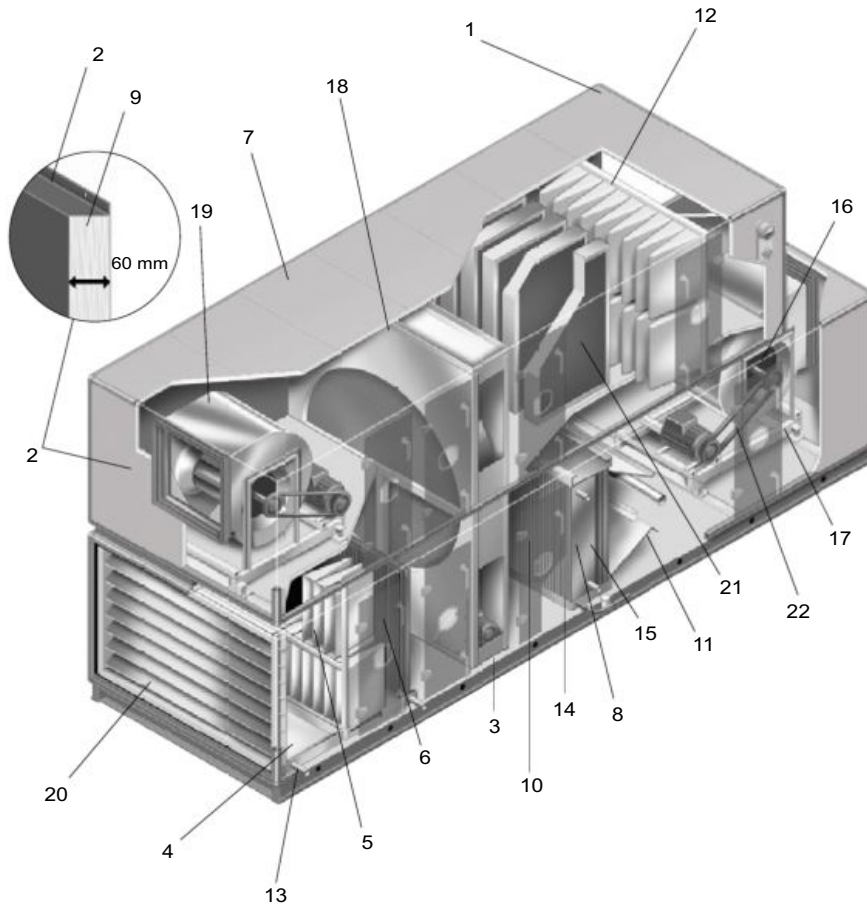

### Easy maintenance

- 10 Various inspection options with generously sized clear opening access doors
- 11 Completely smooth internal surfaces
- 12 Filters easily removable
- 13 Drain pan in the outside air inlet section and filter section equipped with drain (option)
- 14 Cooling coil drain pan fully accessible for cleaning/disinfection
- 15 Moisture eliminator after the cooling coil easily removable
- 16 Long-life fan and motor bearings
- 17 Fans removable from the side

### High-quality built-in components

- 18 Special sorption heat recovery wheels for optimised recovery of heat, cold and humidity
- 19 High-efficiency centrifugal low-noise fans, mounted on vibration isolators with low transmission factor
- 20 Aluminium dampers with UV-resistant double nylon bearings
- 21 Skrim faced sound absorption splitters
- 22 Matched high-efficiency belt drives

## FEATURES AND ADVANTAGES

### Central station air handling unit range (based on a nominal filter loading of 1.11 m<sup>3</sup>/s)

Width \ Height	4	5	6	7	8	9	10	11	12	13	14
2.5	0.56	0.69	0.83								
4	1.11	1.39	1.67	1.81	2.22	2.50	2.78	3.06	3.33		
6	1.67	2.22	2.50	2.92	3.33	3.75	4.17	4.72	5.00	5.56	5.83
8			3.33	3.89	4.44	5.00	5.56	6.11	6.67	7.22	7.78
10					5.56	6.39	6.94	7.64	8.33	9.03	9.72
12						7.50	8.33	9.17	10.00	10.83	11.67
14									11.67	12.78	13.61
16										14.44	15.56
18											
20											

Width \ Height	15	16	17	18	19	20	21	22	23	24	25
2.5											
4											
6	6.39	6.67	7.22	7.50							
8	8.33	8.89	9.44	10.00	10.56	11.11	11.67	12.22	12.78	13.33	
10	10.56	11.11	11.94	12.50	13.33	13.89	14.72	15.28	16.11	16.67	17.50
12	12.50	13.33	14.44	15.00	15.83	16.67	17.50	18.33	19.17	20.00	20.83
14	14.72	15.56	16.67	17.50	18.61	19.44	20.56	21.39	22.50	23.33	24.44
16	16.67	17.78	18.89	20.00	21.11	22.22	23.33	24.44	25.56	26.67	27.78
18				22.50	23.89	25.00	26.39	27.50	28.89	30.00	31.39
20						27.78	29.17	30.56	31.94	33.33	34.72

Preferred range
  Combination with heat recovery
  Other sizes

Note: All air flow values are in m<sup>3</sup>/s. Larger unit sizes are possible.

Module dimension : 160 mm  
 External width : n x module plus 98 mm  
 External height : n x module plus 98 mm  
 Base frame height : 60 mm or 62 mm

Example : type 39HQ12.10  
 Width : 12 x 160 plus 98 = 2.018 mm  
 Height : 10 x 160 plus 98 = 1.698 mm  
 Nominal air flow : 8.33 m<sup>3</sup>/s

## PRECISION CABINET



For version X

- Compact footprint
- Dual-wall construction
- Fan motor assembly with EC motor (electronically commutated)
- PLC control
- Condenser fan variable speed control

## 50CJ

Cooling capacity: 5-47 kW  
Heating capacity: 4-41 kW  
Air flow: 1300 to 12,000 m<sup>3</sup>/h

Precision air conditioning cabinet specially designed for the air handling requirements (filtration, temperature and humidity control) of computer rooms, telecommunications rooms and specific purpose rooms (electronics, sensitive storage, medical, controlled atmosphere rooms, etc.).

Dual-wall construction. The choice of technology used (self regulation depending on the room loads, EC motor: electronically commutated) can reduce the energy consumption.

This unit is quick and easy to install, and particularly simple to use.

## RANGE

The 50CJ cabinet comes in two versions:

- **50CJ W: Chilled water model:**
  - Cooling capacity range: 5 to 27 kW
  - Flow rate: 800 to 6000 m<sup>3</sup>/h
  - 5 sizes available
- **50CJ X: direct expansion model with exterior air condensation unit:**
  - Cooling capacity range: 7 to 47 kW
  - Flow rate: 800 to 12,000 m<sup>3</sup>/h
  - 11 sizes available

## INSTALLATION

### UNDER installation: reversed air supply

Installation 1

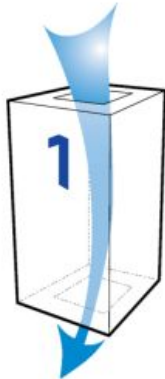

Air supply via raised floor

Installation 3



Front return

Installation 4

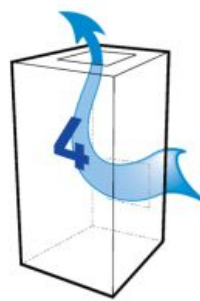

Rear return

### OVER installation: top air supply

Assembly 5

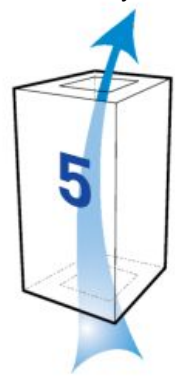

Return air below

## QUICK SELECTION

### 50CJ W

#### Cold water coil

Sizes	W5	W8	W12	W16		W27	
Air flow rate (m <sup>3</sup> /h)	1 300	2 000	2 500	3 000	4 000	5 000	6 000
*Maximum operating pressure with M5 (ePM10 50%) or F7 (ePm1: 60%) filtration	400	400	259	400	85	400	324
Total/sensible cooling capacity (kW)	5/4.8	8/7.6	10.5/9.9	14.7/13.2	18/16.7	23.5/21.5	27/25.1
Water flow rate (m <sup>3</sup> /h)	0,86	1,4	1,8	2,5	3,1	4	4,6
Pressure drop (mWC) (Coil + valve)	4,3	4,9	5,1	4,7	10	4,1	5,2

\* Maximum operating pressure dependent on air flow rate. Take away approximately 20 Pa if there is a hot water coil on 50CJW  
The operation point can be adjusted directly via the controller. Hence all the air flow/operating pressure combinations are possible, with the values in the table above as the maximum values.

Correction factors	7/12 °C	10/15 °C	12/18 °C
22 °C/45%	0,84	0,58	0,44
24 °C/45%	1	0,74	0,5
30 °C/35%	1,48	1,18	0,9

Correction factors to apply to the cooling capacity based on the outdoor temperature and the return air conditions.



## QUICK SELECTION

### 50CJ W

#### Hot water coil

Sizes	W5	W8	W12	W16		W27	
Air flow rate (m <sup>3</sup> /h)	1 300	2000	2 500	3 000	4 000	5 000	6 000
Heating capacity (kW)	4,5	6,2	7,5	11,9	13,7	17,8	19,5
Water flow rate (m <sup>3</sup> /h)	0,21	0,27	0,33	0,5	0,6	0,8	0,9
Pressure drop (mWC) (Coil + valve)	1,3	2,6	4,3	2,1	2,8	1	1,2

Specifications: heating capacity, air 20 °C, pure water 80 °C/60 °C  
 Correction factors to apply to the heating capacity for 90 °C/70 °C water temperature range: 1.23 and 45 °C/35 °C: 0.37.

#### Electric heater

Sizes	W5	W8	W12	W16	W27
Total electrical power (kW)	3		6	9	12
Electrical power (kW)	Stage 1		3		6
	Stage 2		-	-	3
Number of heaters	Stage 1		3 x 1 kW		3 x 2 kW
	Stage 2		-	3 x 1 kW	3 x 1 kW
Total current (A)	4,3		8,7	13	17,3

2 stage or TRIAC electric heater, depending on the option selected

### 50CJ X

#### Cooling coil

Sizes	X5	X8	X10	X12	X15	X19	X24	X31	X36	X38	X48
Air flow rate (m <sup>3</sup> /h)	1 300	2 000	2 500	3 000	4 000	5 000	6 000	7 000	8 000	10 000	12 000
*Maximum operating pressure with M5 (ePM10 50%) or F7 (ePm1: 60%) filtration	400	400	276	400	89	400	324	273	26	330	21
Total/sensible cooling capacity (kW)	7.2/6	8/7.65	10.6/9.7	11/10.9	15/14.7	19/18.6	23.2/22.4	30.1/27.9	35/32	38/37.4	47/45.4

\* Maximum operating pressure dependent on air flow rate. Take away approximately 20 Pa if there is a hot water coil on 50CJ X  
 The operation point can be adjusted directly via the controller. Hence all the air flow/operating pressure combinations are possible, with the values in the table above as the maximum values.

Correction factors	30 °C	32 °C	35 °C	40 °C
24 °C/50%	1,02	1	0,98	0,93
26 °C/50%	1,06	1,04	1,02	0,98

Correction factors to apply to the cooling capacity based on the outdoor temperature and the return air conditions.

#### Hot water coil

Sizes	X5	X8	X10	X12	X15	X19	X24	X31	X36	X38	X48
Air flow rate (m <sup>3</sup> /h)	1 300	2 000	2 500	3 000	4 000	5 000	6 000	7 000	8 000	10 000	12 000
Heating capacity (kW)	4,5	6,2	7,5	11,9	13,7	17,8	19,5	25,8	27,6	37,5	40,9
Water flow rate (m <sup>3</sup> /h)	0,21	0,27	0,33	0,5	0,6	0,8	0,9	1,1	1,2	1,65	1,8
Pressure drop (mWC) (Coil + valve)	1,3	2,6	4,3	2,1	2,8	1	1,2	1,7	1,9	2,8	3,3

Specifications: heating capacity, air 20 °C, pure water 80 °C/60 °C  
 Correction factors to apply to the heating capacity for 90 °C/70 °C water temperature range: 1.23 and 45 °C/35 °C: 0.37.

#### Electric heater

Sizes	X5	X8	X10	X12	X15	X19	X24	X31	X36	X38	X48
Total electrical power (kW)	3		6	9	12	18	24				
Electrical power (kW)	Stage 1		3		6	6	12				
	Stage 2		-	-	3	3	6				
Number of heaters	Stage 1		3 x 1 kW		3 x 2 kW	3 x 2 kW	3 x 4 kW				
	Stage 2		-	3 x 1 kW	3 x 1 kW	3 x 2 kW	3 x 2 kW				
Total current (A)	4,3		8,7	13	17,3	26	34,6				

2 stage or TRIAC electric heater, depending on the option selected

## INDOOR UNIT TECHNICAL DESCRIPTION

### ■ **Casing**

Dual-wall construction.

RAL 7035 grey pre-lacquered panel, removable:

- 1 mm pre-lacquered exterior panels,
- Glass wool, thickness 25 mm, class M0 (A2-s1),
- 0.8 mm galvanised interior panels.

### ■ **Filtration**

- EN 779-2012 efficiency: M5
- ISO16890 efficiency: ePM10 50%.
- Options:
  - EN 779-2012 efficiency: F7
  - ISO16890 efficiency: ePM1: 60%.
- Optional (excl. 50CJX 5/8/10 and 50CJW5/8/12):
  - Dual filtration M5 (ePM10 50%) +F7 (ePM1:60%).
- Filter cells tightly compressed against counter-frame by a gasket to ensure a completely leaktight seal.
- Fouling level monitored by an analogue pressure sensor.

\* except for models W 5/8/12 and X 5/8/12.

### ■ **Cooling coil cross-section**

- Copper tube coil, aluminium fins.
- Aluminium condensate drain pan.
- Model W with 2- or 4-way control valve fitted and connected. Optional thermally insulated flexible connections
- Model X with thermostatic expansion valve.

### ■ **Ventilation section**

- Direct drive centrifugal fan, associated with an electronically commutated (EC motor).
- EC motor: fan adaptation via manual adjustment or "self-regulating" adjustment by the controller, depending on the room load - system air control.
- EC electric motor 1-Ph/230 V/50-60 Hz, 4-pole, class F.
- Air flow rate monitored by an analogue pressure sensor.

### ■ **Electrics box**

Electrical power and control box consisting of:

- Power supply: 3-Ph/400V/50Hz+T+N.
- Emergency stop type disconnect switch.
- Three-phase 400 / 24 V transformer with protection.
- Protection and control of fan motor, and of humidifier and electric heater depending on options selected.
- Regulated by Carrier CCU Controller.
- Return air dry-bulb temperature control.
- Return humidity control:
- Supply humidity control (optional)
- Dehumidification humidity control (optional)
- Options available: water leak detection, fire thermostat and supply air low-limit monitoring.
- Remote control and fault summary contact.
- Condensate drain pump (optional).

### ■ **Accessories**

- Support base for supply air via raised floor:
- Supply plenum.
- Acoustic plenum with sound trap.
- Motorised damper on intake section.
- Additional water leak sensor.
- Fire thermostat.
- Hydraulic connection kit (chilled water and hot water coils).

## Indoor unit options

### ■ **Electric heater**

- Fan-controlled operation.
- 2-stage control (except 3 kW electric heater).
- 2-stage or TRIAC control.
- Two high-limit safety thermostats with automatic and manual reset.

### ■ **Hot water coil**

- 1-row coil made of copper tubes with aluminium fins.
- 2- or 4-way control valve fitted and connected.
- Optional flexible connections.

### ■ **Humidifier**

Immersed electrode humidifier with humidifier information available directly on the Carrier CCU Controller:

- Stainless steel large surface area electrodes,
- Steam flow rate: 3 kg/h for sizes 50CJW5/8/12 and 50CJX5/8/10)
- Steam flow rate: 8 kg/h for other sizes
- Steam cylinder in a single easy to remove component,
- Filling solenoid valves,
- Drain pump,
- Electronics board for operation management,
- Diffusion jet,
- Water supply connection kit.

Operates on municipal water supply only (water conductivity 350 to 1250  $\mu$ S and hardness 15 to 30 °F). Do not use deionised or softened water.

## Indoor unit regulation

### ■ **Unit control and monitoring**

#### Carrier CCU Controller



- 160-character display showing the operating instructions, operating states, faults and solutions. Configurable controller.
- Two fault levels.
- Monitoring of operating times.
- RS 485 output with Jbus/ModBus RTU protocol.
- Can manage rotations, backups and top-ups between units.
- BACNET IP or MSTP gateways optional.
- Optional changeover thermostat (only on W).

## DESCRIPTION OF THE CL2 OUTDOOR UNIT (MODEL X)

---

### ■ **Scroll Compressor**

- Crankcase resistance on models 50-65-75
- Air-cooled condenser, copper tube coil, aluminium fins
- Propeller fan(s) (1 or 2 depending on models) with EC motor
- All-season operation
- Condensation pressure control by fan variable speed control (pressure sensor)
- Refrigerant connections (FLARE connections)
- External operating temperature limits: -15°C to +45°C
- Casing in recyclable synthetic "ABS" material and UV stabilised, light and very solid. Its exclusive and valuable design, makes it easier to integrate into the visual space.

### ■ **Optional equipment**

- Anti-vibration mount kit
- Wall support kit (models 28-35)
- Crankcase resistance on models 28-35
- Thermostatic expansion valve kit
- Blygold pump kit

## TECHNICAL AND ELECTRICAL CHARACTERISTICS

### Indoor unit

		W5	W8	W12	W16	W27			
		X5	X8	X10	X12/15	X19/24	X31/36	X38/48	
<b>Fan motor</b>	Voltage	V							230 V
	Power	kW		1,036		1,029	2,072	2,058	3,087
	Current	A		4,51		4,38	9,02	8,76	13,14
<b>Control circuit (transformer)</b>	Voltage	V							24 V
	Current	A							1
<b>Humidifier (option)</b>	Voltage	V							400
	Power	kW		2,25		6			
	Current	A		3,2		8,7			
<b>Electric heater (option)</b>	Voltage	V							400
	Power	kW		3	6	9	12	18	24
	Current	A		4,3	8,7	13	17,3	26	34,6
<b>Total current without option</b>	Current	A		5,51		5,38	10,02	9,76	14,14
	Rating of main switch	A							16
<b>Total current with humidifier</b>	Current	A		8,71		14,08	18,72	18,46	22,84
	Rating of main switch	A							16
<b>Total current with electric heater</b>	Current	A		9,81	14,21	18,38	27,32	35,76	48,74
	Rating of main switch	A		16		25	40	63	
<b>Total current all options</b>	Current	A		13,01	17,41	27,08	36,02	44,46	57,44
	Rating of main switch	A		16	25	40		63	

### CL2 condensation unit outdoor unit (model X)

Sizes		28	35	50	65	75	
<b>Compressor</b>	Quantity	1					
	Type	SCROLL					
	Oil capacity	l		1,25		1,7	
	Oil type	POE					
	Voltage	400 V - 3 Ph - 50 Hz					
	Maximum current	A	6,9	7,6	10,3	11,2	14,3
<b>Refrigerant</b>		R410A					
<b>Refrigerant weight</b>	kg	1,6		2,65	2,75	3	
<b>Power and current</b>	W/A	45 W/0.2 A Option <sup>(1)</sup>		45 W/0.2 A			
<b>Crankcase heater</b>							
<b>Coil type</b>		Grooved copper tubes - aluminium fins					
<b>Fan</b>	Quantity	1		2			
	Type	Propeller					
	Nominal flow rate	m <sup>3</sup> /h	2350	2770	4700	5540	5000
	Speed	Rpm	700	904	700	904	
	Maximum current	A	0,46	0,97	0,92	1,94	1,94
<b>Rated voltage of unit</b>	V	400 V - 3 Ph+N - 50 Hz					
<b>Total current</b>	A	7,5	8,3	11,3	12,6	15,7	
<b>Start-up current</b>	A	36	49	65,5	75,5	102,5	
<b>Electrical cables not supplied*</b>	mm <sup>2</sup>	5G1.5	5G2.5	5G4		5G6	
<b>Recommended cables for the proximity switch</b>	Am	10		16			
<b>Refrigerant connections</b>	∅ liquid line	inches		3/8"		1/2"	
	∅ intake line	inches		5/8"	3/4"		

\* Cable with 2 or 3 charged conductors in a raceway or duct, exposed mounting, for temperatures below 60 °C and a maximum length of 30 m.  
**Note:** for different conditions, refer to the current standard in the country of installation (example for France: NFC 15-100)

## SOUND PRESSURE LEVEL

### Indoor unit

Sizes	Chilled water model				27										
	5	8	12	16	5	8	10	12	15	19	24	31	36	38	48
Air flow rate (m³/h)	1 300	2 000	2 500	3 000	4 000	5 000	6 000	7 000	8 000	10 000	12 000				
Sound pressure level (dBA)	49	53	58	57	61	59	63	60	63	60	64				

Sound pressure level of indoor unit at 2 m unrestricted space, air supply connected, +/-3 dB.

### CL2 outdoor unit (model X)

Sizes	5	8	10	12	15	19	24	31	36	38	48
Models	28	28	35	35	50	65	75	2x50	2x65	2x65	2X75
Sound pressure level (dBA)	39	39	45	45	43	47	47	46	50	50	50

Sound pressure level of outdoor unit, at 5 m, 1.5 m from floor, in a free field, directivity 2 and +/-3 dB.

## COIL WEIGHT AND CONNECTION

### Unit weight

#### Indoor unit

Chilled water model sizes	W5	W8	W12	W16	W27						
Direct expansion model sizes	X5	X8	X10	X12	X15	X19	X24	X31	X36	X38	X48
Weight of indoor unit (kg)	115	120	125	280	310	375	480				

#### Indoor unit

Direct expansion units	X5	X8	X10	X12	X15	X19	X24	X31	X36	X38	X48
Outdoor units (CL2) no./type	1x28	1x28	1x35	1x35	1x50	1x65	1x75	2x50	2x65	2x65	2x75
Unit weight of outdoor unit (kg)	64	69	69	69	101	112	118	101	112	112	118

### Coil connections

#### Indoor unit

##### Cold water coil

Sizes	W5	W8	W12	W16	W27						
Inlet/outlet connections	G 1/2" M	G 3/4" M	G 3/4" M	G 3/4" M	G 1" M	G 1" M	G 1" M	G 1" M	G 1" M	G 1" M	G 1 1/4" M
Condensate drainage*	Diam 32										

##### Direct expansion coil

Sizes	X5	X8	X10	X12	X15	X19	X24	X31	X36	X38	X48
Intake pipe	G 5/8" M	G 5/8" M	G 3/4" M	G 7/8" M	G 7/8" M	G 1" 1/8" M	G 1" 1/8" M	G 2 X 7/8" M	G 2 X 7/8" M	G 2 X 1" 1/8" M	G 2 X 1" 1/8" M
Liquid pipes	1/2"	1/2"	1/2"	1/2"	1/2"	1/2"	1/2"	2 x 1/2"	2 x 1/2"	2 x 1/2"	2 x 1/2"
Condensate drainage*	Ø 32 mm										

##### Hot water coil

Chilled water model sizes	W5	W8	W12	W16	W27						
Direct expansion model sizes	X5	X8	X10	X12	X15	X19	X24	X31	X36	X38	X48
Inlet/outlet connections	G 1/2" M	G 1/2" M	G 1/2" M	G 1/2" M	G 3/4" M	G 3/4" M	G 3/4" M	G 3/4" M	G 3/4" M	G 3/4" M	G 3/4" M

#### Outdoor unit

Direct expansion model sizes	X5	X8	X10	X12	X15	X19	X24	X31	X36	X38	X48
Outdoor units no./type	1x28	1x28	1x35	1x35	1x50	1x65	1x75	2x50	2x65	2x65	2x75
Intake pipe	5/8"	5/8"	3/4"	3/4"	3/4"	7/8"	7/8"	2 x 3/4"	2 x 7/8"	2 x 7/8"	2 x 7/8"
Liquid pipes	3/8"	3/8"	3/8"	3/8"	3/8"	3/8"	1/2"	2 x 3/8"	2 x 3/8"	2 x 3/8"	2 x 1/2"
Condensate drainage*	Diam 32										

Chilled water coil connections: inlet on threaded coupling and outlet on threaded control valve.

Condensate drain connection on smooth coupling.

\* Drain connections if optional pump is fitted: Ø 6

## DIMENSIONS AND OPERATING AREA

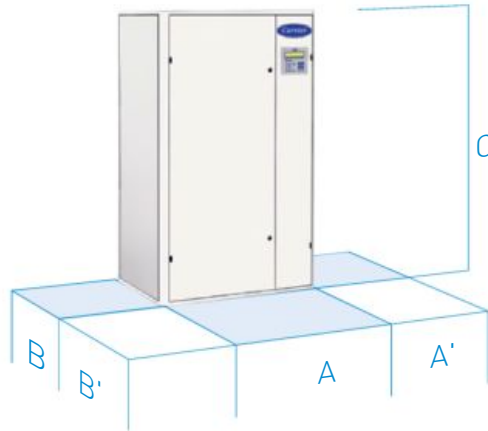

### Indoor unit

Units	Dimensions (mm)				
	A	A'	B	B'	C
W5 or X5	675	500	500	700	1700
W8 or X8	675	500	500	700	1700
W12 or X10	675	500	500	700	1700
W16 or X12/15	850	500	780	700	1900
W27 or X19/24	1150	500	780	700	1900
X31/36	1490	500	780	700	1900
X38/48	1990	500	780	700	1900

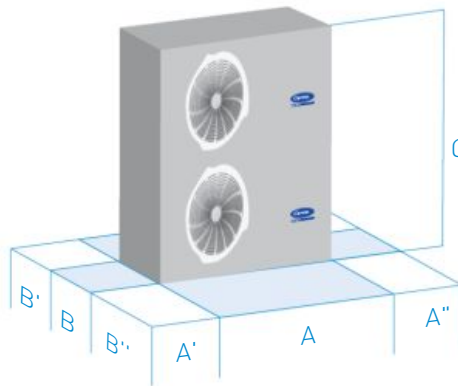

### Outdoor unit (CL2)

Models	Dimensions (mm)						
	A	A'	A''	B	B'	B''	C
28	1035	150	1000	450	150	1500	732
35	1035	150	1000	450	150	1500	732
50	1035	150	1000	450	150	1500	1332
65	1035	150	1000	450	150	1500	1332
75	1035	150	1000	450	150	1500	1332



## OPERATING LIMITS

### Chilled water (W)

Water circuit	Maximum pressure: PN16	Minimum water inlet temperature: 5 °C (Consult us for other values)
		Maximum water inlet temperature: 80 °C (Consult us for other values)
Indoor temperature		Minimum air inlet temperature: 12 °C, and according to return humidity
		Maximum air inlet temperature: 45 °C and according to return humidity (Weight in water, condensed <0.8 g of water/Kg of dry air)
Power supply		3PH/400V+E+N

### Direct expansion (X)

Indoor temperature		Minimum air inlet temperature: 18 °C, and according to return humidity
		Maximum air outlet temperature: 28 °C and according to return humidity (Weight in water, condensed <0.8 g of water/Kg of dry air)
Outdoor temperature		Minimum air inlet temperature: -15 °C
		Maximum air inlet temperature: 45 °C
Power supply	Indoor unit	3PH/400V+E+N
	Outdoor unit(s)	3PH/400V+E+N



## PRECISION CABINET



Wide range of single unit  
water chillers

Compact and attractive design

EC motor saves energy

Self-adjusting control

Easy installation

## 50CO

Cooling capacity: 40-100 kW  
Heating capacity: 18-73 kW  
Air flow: 10,000 to 27,000 m<sup>3</sup>/h

Close control unit specifically adapted to meet the needs of rooms with a high heat load or sensitive locations (data centres, computer rooms, autocom rooms, etc.).

The choice of technology used (self-adjusting control which adapts to the room loads, electronically commutated EC motor) can reduce energy consumption.

Thanks to its skilful design, the **50CO** integrates seamlessly into its intended location.

## RANGE

### 50CO W Chilled water model

Cooling capacity range: 40 to 127 kW

Nominal air flow range: 10,000 to 27,000 m<sup>3</sup>/h

5 sizes available

## INSTALLATION

### Fitting UNDER

Air supply via raised floor



### Fitting OVER

Front return



Return air below

## QUICK SELECTION

### Cold water coil

Sizes	W40		W53		W78		W100	
	Nominal <sup>(1)</sup>	Maximum <sup>(2)</sup>	Nominal <sup>(1)</sup>	Maximum <sup>(2)</sup>	Nominal <sup>(1)</sup>	Maximum <sup>(2)</sup>	Nominal <sup>(1)</sup>	Maximum <sup>(2)</sup>
<b>Air flow (m<sup>3</sup>/h)</b>	10 000	13 300	13 300	13 300	18 800	20 500	24 500	27 000
<b>Maximum operating pressure with M5 filter (Pa)</b>	400	171	229	229	400	400	343	157
<b>Maximum operating pressure with F7 filter (Pa)</b>	400	60	140	140	400	400	261	68
<b>Sensible cooling capacity (kW)</b>	40	45	55	53	78	78	100	100
<b>Nominal capacity (kW) *</b>	3,7		3,7		7,1		7,1	
<b>Nominal current (A) *</b>	6,4		6,4		11,8		11,8	

(1) Conditions: Return air 24°C 45% (RH) - Water temperature: 7/12°C

(2) Conditions: Return air 26°C 40% (RH) - Water temperature: 10/15°C

\* Excluding electrical heater and humidifier option

### Hot Water Coil (option)

Sizes	W40		W53		W78		W100	
	Nominal	Maximum	Nominal	Maximum	Nominal	Maximum	Nominal	Maximum
<b>Air flow (m<sup>3</sup>/h)</b>	10 000	13 300	13 300	13 300	18 800	20 500	24 500	27 000
<b>Heating capacity (kW)<sup>(1)</sup></b>	36	40	44	44	63	66	71	73
<b>Heating capacity (kW)<sup>(2)</sup></b>	18	21	23	23	33	34	37	38

(1) 17°C - 80/60°C

(2) 17°C - 45/40°C

### Electric heater (option)

Sizes	W40	W53	W78	W100
<b>Power (kW)</b>	12	18	24	33,6
<b>Total current (A)</b>	17,3	26	34,7	48,6

## QUICK SELECTION

### Humidifier (Option)

Sizes	W40 to W100
Steam flow rate (kg/h)	8
Electrical power (kW)	6
Current (A)	8,7

## DESCRIPTION

### ■ Casing

Dual-wall construction (with MO / A1 fire rating).  
RAL 7035 and 7024 grey precoated removable panel.  
- 0.8mm painted precoated exterior panel.  
- Mineral wool, 25 mm thick.  
- 0.8 mm galvanised interior panel.

### ■ Filtration

Filter cells.  
Filter cells kept compressed against the counter frame with the gasket directly on the filter cells.  
EN 779-2012 efficiency: M5  
ISO16890 efficiency: ePM10 50%  
Or  
EN 779-2012 efficiency: F7  
ISO16890 efficiency: ePM1: 60%  
Filter fouling value monitored by analogue sensor and displayed by the controller.

### ■ Cooling coil cross-section

Copper tubes, aluminium fins.  
Stainless condensate drain pan.  
Stainless coil flanges (option).  
2-way or 3-way control valve fitted and connected.

### ■ Ventilation section

Centrifugal plug fan, associated with an electronically commutated motor (EC motor).  
EC motor: fan adaptation via manual adjustment or "self-regulating" adjustment by the controller, depending on the room load - system air control.

The fan also has a ModBus card which allows faults and settings such as the actual power input, current, rotation speed, etc. to be transmitted.

### ■ Electrics box

Power, command and control electrics box consisting of:  
- 3-phase 400 V power supply + Earth.  
- Main disconnect switch.  
- Three-phase 400 V 50 Hz transformer with protection.  
- Protection and control of all electrical components by a circuit breaker and contact switch.  
- Automatic CARRIER CCU Controller.  
- Return air dry-bulb temperature control.  
- Return humidity control, in supply or dehumidification mode.  
- Water leak detection as standard.  
- Remote control and fault summary contact.

### ■ Accessories (option)

Free cooling box.  
Support sub-base for supply air via raised floor.  
Cased sub-base with grille or damper.  
Supply plenum.  
Motorised damper on intake section.  
Fire thermostat.  
Supply air low limit sensor.  
BACnet gateway (IP or MSTP).  
Raised floor pressure management.  
Changeover thermostat.

## OPTIONS

### ■ Electric heater

Fan-controlled operation.  
Control by 2-stage operation or by progressive action (TRIAC).  
High-limit safety thermostat with automatic and manual reset.

### ■ Hot water coil

1-row coil made of copper tubes with aluminium fins.  
2- or 4-way progressive action valve fitted, and connected.

### ■ Humidifier

Humidifier with immersed electrodes and an electronic board to transmit all information relating to the humidifier directly to the CARRIER CCU Controller.  
- Stainless steel large surface area electrodes.  
- Flow rate of 8 kg/h, depending on the model.  
- Steam cylinder in a single easy to remove component.  
- Drain pump and filling solenoid valve.  
- Electronics board for operation management.  
- Diffusion duct.

Operates using municipal water supply only (water conductivity of between 350 and 1250 µS inclusive and hardness between 15 and 30 °F). Do not use deionised or softened water.

## CONTROL

Unit control and monitoring:

### CARRIER CCU Controller

- 160-character display showing the operating instructions, operating statuses, faults and solutions. Configurable controller.
- Two fault levels.
- Monitoring of operating times.
- RS 485 output with Jbus/ModBus protocol.
- Master/slave type management possible.
- BACnet gateway (IP or MSTP) optional
- Optional management of pressure in raised floor
- Optional changeover thermostat
- Bus management between the centrifugal plug fan and the controller.
- Transmits fan faults and settings such as the actual power input, current, rotation speed, etc. to the controller.



## ELECTRICAL SPECIFICATIONS

Sizes		W40	W53	W78	W100
Fan motor	Voltage (V)	400			
	Power (kW)	3,4		6,8	
	Current (A)	5,4		10,8	
Control circuit (transformer)	Voltage (V)	24			
	Current (A)	1			
Humidifier (option)	Voltage (V)	400			
	Power (kW)	6			
	Current (A)	8,7			
Electric heater (option)	Voltage (V)	400			
	Power (kW)	12	18	24	33,6
	Current (A)	17,4	26	34,6	48,4
Total current without option	Current (A)	6,4	6,4	11,8	11,8
	Disconnect switch rating (A)	16			
Total current with humidifier	Current (A)	15,1	15,1	20,5	20,5
	Disconnect switch rating (A)	25		40	
Total current with electric heater	Current (A)	23,8	32,4	46,4	60,2
	Disconnect switch rating (A)	40		63	80
Total current all options	Current (A)	32,5	41,1	55,1	68,9
	Disconnect switch rating (A)	40		63	80

## CONNECTIONS

### Cold water coil

Sizes	W40	W53	W78	W100
Inlet	G1"1/4 (M)	G1"1/4 (M)	G1"1/2 (M)	G1"1/2 (M)
Outlet	G1"1/4 (F)	G1"1/4 (F)	G1"1/2 (F)	G1"1/2 (F)

### Hot water coil

Sizes	W40	W53	W78	W100
Inlet	G3/4" (M)	G3/4" (M)	G3/4" (M)	G3/4" (M)
Outlet	G3/4" (M)	G3/4" (M)	G3/4" (M)	G3/4" (M)



## DIMENSIONS

### W40 - W53

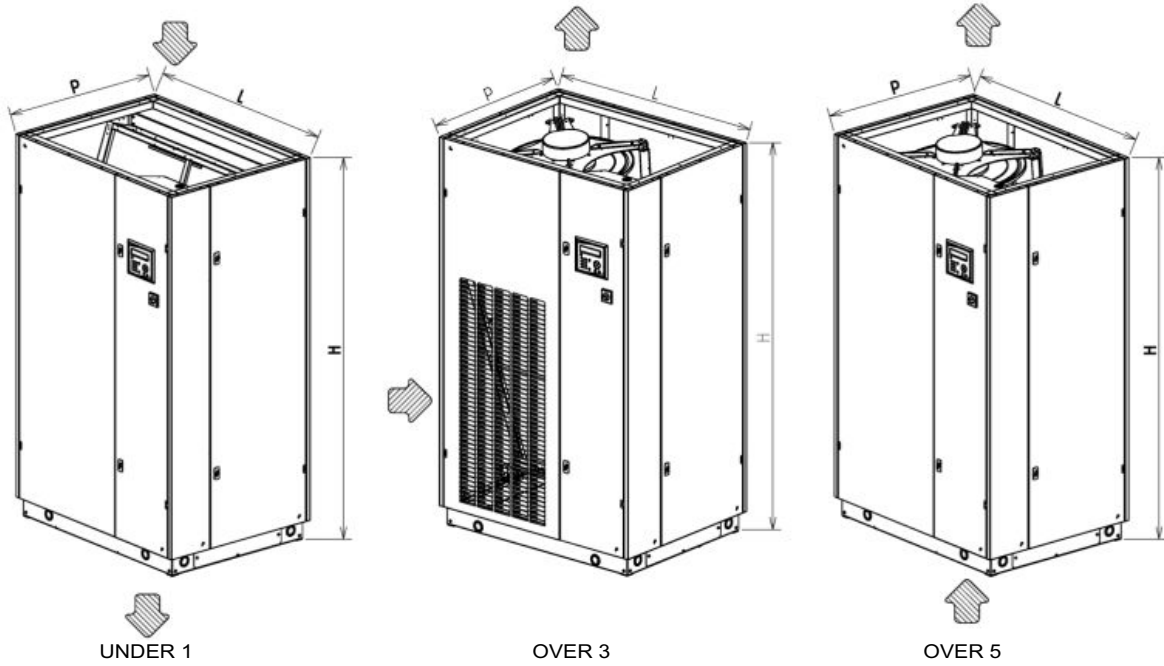

### W78 - W100

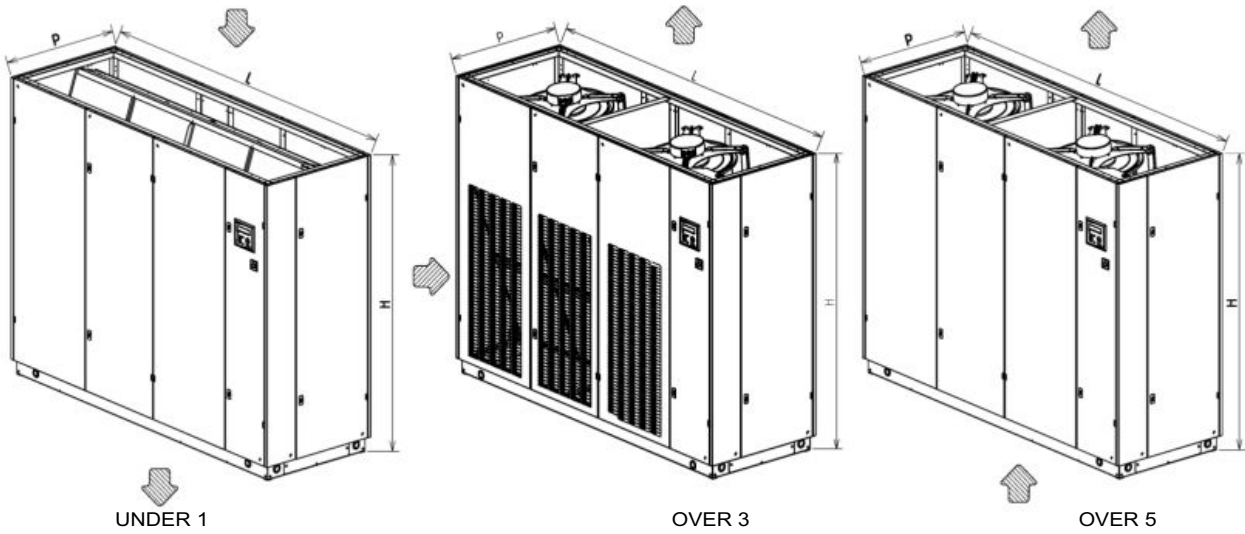

Sizes	Dimensions (mm)			Weight (kg)
	H	L	D	
W40	1990	1190	890	350
W53		1520		385
W78		2070		545
W100		2620		635

## OPERATING LIMITS

Water circuit	Maximum pressure: PN16	Minimum water inlet temperature: 5 °C (Consult us for other values)
		Maximum water inlet temperature: 80 °C (Consult us for other values)
Indoor temperature		Minimum air inlet temperature: 12 °C, and according to return humidity
		Maximum air inlet temperature: 45 °C and according to return humidity (Weight in water, condensed <0.8 g of water/Kg of dry air)
Power supply		3PH/400V + earth

**NEW**

## PACKAGED ROOFTOP UNITS WITH R-454B



- Low environmental impact
- High full and part load efficiency
- Compact and simple to install
- Low refrigerant charge
- Low sound level
- Energy recovery
- Variable speed EC fans

## 50FF/FC 020 - 093 R-454B\*

\* Also available in R-410A

Nominal cooling capacity 22,4 - 90.4 kW  
 Nominal heating capacity 22,0 - 89.6 kW

The **50FF/FC R-454B** packaged rooftop range consists of autonomous compact air-air units of horizontal design, rooftop type.

- **50FF:** for **cooling-only** operation.
- **50FC series:** for **reversible heat pump** operation.

The range of available capacities in the series allows for the air conditioning of medium and large surface areas which are common in shopping malls, food retail, logistics and many other commercial and industrial applications.

50FF/FC units are designed for optimized part-load management in achieving the highest levels of seasonal efficiency, exceeding the limits set by regulation.

With its mono-block lightweight construction, the units feature a self-supporting frame, designed to ease the installation and maintenance works.

The units integrate the latest technological innovations:

- Multi-scroll compressors in tandem.
- Electronic expansion valves.
- Variable speed EC fans.
- Auto-adaptative microprocessor control.

For maximum adaptability, a number of options is available to meet any operating requirement:

- Exhaust air energy recovery.
- Economizer.
- Indoor air quality management.
- Installation roof curbs.
- Zoning with variation of airflow.
- Auxiliary heating modules.
- Extended operation limits.



CARRIER participates in the ECP programme for RT  
 Check ongoing validity of certificate:  
[www.eurovent-certification.com](http://www.eurovent-certification.com)

## CUSTOMER BENEFITS

### Outstanding performance

50FF/FC R-454B units are designed for optimized part-load management in achieving the highest levels of seasonal efficiency, exceeding the limits set by regulation.

ECO  
DESIGN  
READY

SEER  
UP TO  
5,01

SCOP  
UP TO  
3,70

The unit integrates the latest technological innovations:

- Reduced refrigerant charge of non-ozone depleting R-454B refrigerant with low GWP.
- Multi-scroll compressors in tandem optimized for R-454B refrigerant.
- Electronic expansion valves.
- Outdoor EC fans with variable speed.
- Supply EC plug-fans with direct drive and variable speed.
- "50FC" auto-adaptative microprocessor control that optimizes the performance at part load conditions and the operational limits in all seasons.



### Intelligence and connectivity

The advanced "50FC" intelligent control system displays operating parameters in real-time, making it intuitive and particularly user-friendly. The 50FF/FC range is also characterized by a brand new smart energy monitoring function that provides users with smart data such as electrical energy consumption in real-time, supplied cooling and heating energy as well as instantaneous and average seasonal energy efficiency values.

It also guarantees easy installation and integration into the building management system.

- Plug & play solution fully programmed and set up from the factory.
- Wide supervision offer from 1 to 300 units.
- Communication with all building management system protocols through Modbus, BACnet, Konnex, TCP/IP, SNMP V1-2-3, FTP and HTTP.

### Adaptability

The 50FF/FC range offers a wide range of options to address the most specific requirements to be the **perfect solution for every application** with maximum comfort, energy efficiency and indoor air quality in mind.

These options include:

- Exhaust air energy recovery.
- Economizer for fresh air and free-cooling.
- Indoor air quality management.
- Adjustable or adaptation roof curbs.
- Auxiliary heating systems.
- Extended operation limits up to -15°C in heating.
- Multizone management

- Heat recovery water coil.
- Low return temperature option for storage applications.

### Extensive scope of applications

Some options in the 50FF/FC units are aimed at applications with a wider temperature range:

- Air zoning to control up to 4 zones or in case of large surfaces with high thermal dispersion.
- Heat recovery coil using energy rejected by food refrigeration system or industrial process.
- Low return temperature 15°C in cooling mode operation which allows to answer the request of certain application as food conservation in large store facilities.

### Energy savings

This range has been designed to reduce energy consumption with advanced features:

- Variable ventilation with electronic plug-fans.
  - In tertiary sector installation, a high percentage of the annual air conditioning energy consumption comes from the use of fans for transporting air. Using fans which are more efficient has a direct impact on reducing consumption.
- Low pressure drop filters.
- Free-cooling allows to make best use of outdoor air conditions when these are more favourable than the return air conditions. This allows the cooling capacity to be reduced. Up to 30% energy savings due to the cooling capacity reduction.
- Energy recovery systems:
  - **Active recovery:**
    - High performances in mild weather
    - Additional cooling circuit, independently controlled, for energy recovery from the exhaust air.

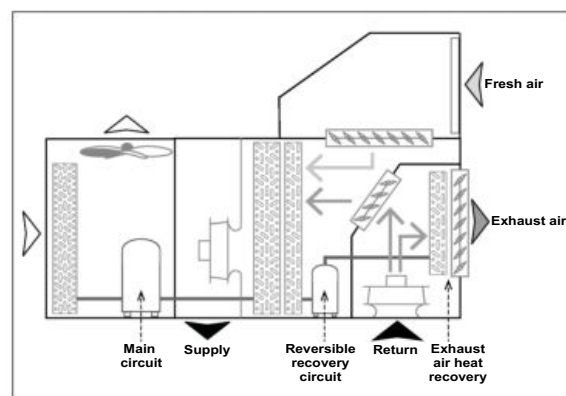

#### - Passive recovery:

- Recommended with low outdoor temperatures in winter, and high fresh air ratios.
- A rotary heat exchanger, coupled to the machine, transfers heat and humidity from the air-conditioned room's return air to the fresh air used for ventilation, before its discharged outdoors.

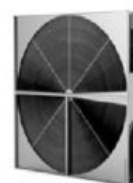

All these energy-efficient solutions lead to substantial cost savings.

## CUSTOMER BENEFITS

### Indoor air quality

The 50FF/FC range offers a wide range of technological features dedicated to improve and maintain the highest level of indoor air quality:

- Ventilation of spaces with outdoor air. It reduces indoor pollutants to maintain indoor air quality.
- Air filtration. It is an efficient way to reduce particles that can harm our health. Filter fouling detector determines when the filter needs to be replaced.
- CO<sub>2</sub> sensors that allow ventilation based on the comparison of CO<sub>2</sub> levels between indoor and outdoor sources.
- Air flow control. It ensures proper comfort in spaces: temperature, humidity, air flow and overpressure.

Discover more about Carrier's approach to Healthy Buildings on:

<https://www.corporate.carrier.com/healthybuildings/>

### Low sound levels

50FF/FC units provide a low-noise level during operation thanks to design optimization and the latest technology to meet the most exigent requirements.

- Up to 70% of the operation time below half-load.
- Sound level reduction in partial load operation.
- Night operation mode available with free-cooling and disabling compressors. This also helps to reduce the sound level during night periods.

### Easy and fast installation

With its compact construction, the 50FF/FC units feature a self-supporting frame, designed to ease the installation and maintenance process.

The units are connected directly to an air distribution ductwork without additional elements or equipment, pipes, cables, etc. taking no floor space at all. This design reduces the cost of installation, facilitates a quick connection and ensures reliable operation.

All components are easily accessible via removable panels to minimize downtime.

- Vertical supply/return airflow configurations are ideal for new construction or retrofit projects.
- Horizontal airflow configurations are ideal for replacement or applications such as through-the-wall where sound must be attenuated before the duct penetrates the roof.

Optionally the units can be installed on pre-assembly roof curbs with adjustable height.

The "50FC" intelligent control system ensures easy maintenance thanks to advanced functions for monitoring the operation of the unit and the alarms produced.

### Superior reliability

The 50FF/FC range has been designed to ensure robustness throughout the lifecycle of the units. The high-reliability of the units is the result of **high-quality material and components** combined with the **highest quality standards** in terms of manufacturing and laboratory testing.



### EcoPassport®

The PEP ecopassport® programme provides an international reference framework for procedures enabling manufacturers to communicate the environmental specifications of their products in the form of an eco-declaration, known as the Product Environmental Profile (PEP).

The PEP ecopassport® programme guarantees that PEPs are created, checked and communicated correctly according to the requirements of standard ISO 14025 and standard IEC/PAS 62545.

The Life Cycle Analysis (LCA) PEP is the environmental identity card for an item of equipment which details the environmental impacts of the product during its life cycle according to **eight mandatory indicators**:

1. Global Warming Potential
2. Impact on the ozone layer
3. Acidification of soil and water
4. Eutrophication of water
5. Photochemical ozone creation
6. Abiotic resource depletion
7. Fresh water consumption
8. Total use of primary energy during the life cycle

**CARRIER** is the first HVAC manufacturer to provide PEPs for rooftops, not only the 8 mandatory indicators, but all **27 indicators**.

Products with certified environmental profiles are used to support methods to assess building sustainability such as BREEAM or LEED. They give additional recognition for materials with robust environmental product declaration types using manufacturer data.

The PEP of **50FF/FC R-454B** can be downloaded from the PEP ecopassport® website: <http://www.pep-ecopassport.org>





# NOMENCLATURE OF THE UNIT FOR CONFIGURATION

A	B	C	D	E	F	G	H	I	J	K	L	M	N	O	P	Q	R	S	T	U	V	W	X	Y
50FC	0020	A	4	B	B1	LL	000	S	N	A	H	S	000	0000	0000	0	0	AA00	00	A00	000	AA00	0000	0000

**A: Unit type**

50FF: air/air cooling-only  
50FC: air/air heat pump

**B: Unit model**

1 circuit: 0020/0028/0037/0040/0045/0047  
2 circuits: 0052/0058/0062/0070/0074/0086/0093

**C: Version of the series**

A: Current version

**D: Electrical power**

4: 400V / 3ph + N / 50Hz  
5: 400V / 3ph / 50Hz

**E: Type of refrigerant**

B: R-454B

**F: Flow + Assembly**

B1: Standard assembly  
B2: Economizer, 2 dampers  
BF: 100% fresh air  
B3: Economizer, 3 dampers  
BX: Axial fan in return section  
BP: EC plug-fan in return section  
BA: Cooling recovery circuit with EC plug-fan in return section  
BT: Return top box with EC plug-fan or centrifugal fan  
BB: Cooling recovery circuit with EC plug-fan or centrifugal fan in return top box  
BW: Heat recovery wheel module

**G: Coil coating : Indoor - Outdoor**

LL - Indoor coil - Outdoor coil  
L: Aluminium L: Aluminium  
P: Polyurethane P: Polyurethane  
N: Inera® N: Inera®  
Y: Blygold® Y: Blygold®

**H: Heating**

000: Without auxiliary heating  
BAx: Gas burner, 3 power outputs:  
x = F (Low) / M (Nominal) / S (High)  
RAx: Electrical heaters, 3 power outputs:  
x = F (Low) / M (Nominal) / S (High)  
HAx: Hot water coil, 2 options:  
x = S (Standard) / F (Very low outdoor temperature)

**I: Protection for low outdoor temperature**

S: Without protection  
A: Freeze protection OAT lower than -10°C  
B: Freeze protection OAT lower than -14°C  
C: Freeze protection OAT lower than -10°C + spring shut-off dampers  
D: Freeze protection OAT lower than -14°C + spring shut-off dampers

**J: Supply fan**

F: Low available pressure  
N: Nominal available pressure  
M: Nominal available pressure (aluminium)  
S: High available pressure

**K: Air filtration + droplet eliminator**

A: G4  
B: G4+ droplet eliminator  
C: G4 low pressure drop  
D: G4 low pressure drop + droplet eliminator  
E: G4 + M6  
F: G4 + M6 + droplet eliminator  
G: G4 + F7  
H: G4 + F7 + droplet eliminator  
I: G4 + F9

J: G4 + F9 + droplet eliminator  
K: G4 l.p.d. + F7  
L: G4 l.p.d. + F7 + droplet eliminator  
M: G4 l.p.d. + F9  
N: G4 l.p.d. + F9 + droplet eliminator  
O: M6 + F7  
P: M6 + F7 + droplet eliminator  
Q: M6 + F9  
R: M6 + F9 + droplet eliminator  
S: F7 + F9  
T: F7 + F9 + droplet eliminator  
U: F9 + F9  
V: F9 + F9 + droplet eliminator

**L: Outdoor fan**

L: AC (2-speed)  
H: EC (electronic)

**M: Insulation**

S: Standard insulation  
M: Euroclass A2-s1, d0 (M0) insulation

**N: Indoor circuit**

000 - Without optional accessories  
A: Condensate drain pan in stainless steel  
A: Room overpressure management  
A: Filter fouling detector

**O: Outdoor circuit**

0000 - Without optional accessories  
A: Fresh air safety grid  
A: Outdoor coil protection grid  
A: Antivibration mounts  
A: Droplet eliminator at the fresh air intake

**P: Heat recovery wheel**

0000 - Without optional accessories  
B: G4 low pressure drop  
A: Wheel speed with on/off control  
B: Wheel speed with variable control  
A: Channel spacing of 2,0 mm  
B: Channel spacing of 2,5 mm  
A: Material: Aluminium  
B: Material: Aluminium with epoxy  
C: Material: Hybrid wheel  
D: Material: aluminium with silicagel

**Q: Extra heating**

0: Without extra heating  
B: Heat recovery coil  
C: Preheater (electrical coil) in fresh air (N)  
D: Preheater (electrical coil) in fresh air (F)

**R: Special applications**

0: Without special applications  
C: Air zoning  
D: Low return temperature application  
L: Low T application + Air zoning  
I: 100% fresh air  
M: 100% fresh air + Air zoning

**S: Sensors**

0000 - Without options  
A: Smoke detection control unit  
A: CO<sub>2</sub> sensor environment installation  
B: CO<sub>2</sub> sensor ducted installation  
C: CO<sub>2</sub> sensor on the SHRD network  
A: 1 sensor RS485  
B: 2 sensors RS485  
C: 3 sensors RS485  
D: 4 sensors RS485  
E: 1 sensor NTC  
A: Ambient temperature sensor  
B: Ambient temperature+humidity sensor  
C: Ambient sensor on the SHRD network

**T: Economizer management + Outdoor hum.**

00 - Without economizer + without sensor  
A: Outdoor humidity sensor on the unit  
B: Outdoor hum. sensor on SHRD network  
A: Thermal management  
B: Thermoenthalpic management  
C: Enthalpic management

**U: Terminal + Unit communication**

000 - Without terminal + stand-alone unit + without communication card  
A: Card RS485 Modbus  
B: Card Ethernet PCoWeb  
D: Card Ethernet BACnet™  
E: Card RS485 BACnet™  
F: Card RS485 Konnex  
0: Stand-alone unit  
A: Master unit  
B: Slave unit  
A: Graphic terminal in electrical cabinet  
B: User terminal in electrical cabinet  
C: Graphic terminal in the cabinet + User terminal remote up to 100 m  
D: User terminal in the cabinet + Graphic terminal remote up to 200 m  
E: Graphic terminal in the cabinet + Graphic terminal remote up to 200 m  
F: Touch panel in electrical cabinet  
G: Touch panel in the cabinet + Graphic terminal remote up to 200 m  
H: Touch panel in the cabinet + User terminal remote up to 100 m

**V: Miscellaneous item 1**

000 - Without options  
A: On-off control of an humidifier  
B: Proportional control of a humidifier  
A: Electrical energy meter  
B: Cooling capacity & elec. energy meter  
Unused

**W: Miscellaneous item 2**

AA00 - Switching devices + std phase relay  
A: Compressor soft starter  
A: Varnish protection  
B: High performance phase relay  
Unused

**X: Return fan**

0000 - Without return fan  
A: Centrif., low flow and nominal pressure  
B: Centrif., low flow and high pressure  
C: Centrif., nominal flow and nominal press.  
D: Centrif., nominal flow and high pressure  
E: Centrif., high flow and nominal pressure  
F: Centrif., high flow and high pressure  
G: Centrif., low flow and low pressure  
H: Centrif., nominal flow and low pressure  
I: Centrif., high flow and low pressure  
M: Plug-fan, nominal pressure (aluminium)  
Unused

**Y: Indoor air direction**

0000 - Lower direction  
0: Lower supply and lower return  
1: Lateral supply and lower return  
2: Lower supply and lateral return  
3: Lateral supply and lateral return  
4: Upper supply and lower return  
5: Lateral supply and upper return  
6: Upper supply and lateral return  
7: Lower supply and upper return  
8: Upper supply and upper return  
Unused  
0: Without pre-assembly roof curbs  
1: With pre-assembly roof curbs  
Unused



## NOMENCLATURE OF ROOF CURB / BURNER (OPTIONS)

A	B	C	D	E	F	G	H	I	J	K
CU0_50	020_047	A	B1	000	000	00000	S	00S	000	00

### A: Unit type

CU0\_50: Roof curb  
CUQ\_50: Roof curb + Gas burner

### B: Unit model

020\_047  
052\_062  
070\_093

### C: Version of the series

A: Current version

### D: Flow + Assembly

B1: Standard assembly  
B2: Economizer, 2 dampers  
BF: 100% fresh air  
B3: Economizer, 3 dampers  
BX: Axial fan in return section  
BP: EC plug-fan in return section  
BA: Cooling recovery circuit with EC plug-fan in return section  
BT: Return top box with EC plug-fan or centrifugal fan  
BB: Cooling recovery circuit with EC plug-fan or centrifugal fan in return top box  
BW: Heat recovery wheel module

### E: Roof curb type

000: Without roof curb  
00A: Pre-assembly roof curb  
AAA: Adaptation roof curb  
AAB: Adaptation roof curb  
BBA: Adaptation roof curb  
BBB: Adaptation roof curb  
CCA: Adaptation roof curb  
DDA: Adaptation roof curb  
DDB: Adaptation roof curb

### F: Gas burner

000: Without burner  
BAx: Gas burner, 3 power outputs:  
x = F (Low) / M (Nominal) / S (High)

### G: Country + Type of gas

00000 Without burner  
IT\_A Italy ..... G20  
IT\_B Italy ..... G30  
IT\_C Italy ..... G31  
ES\_A Spain ..... G20  
ES\_C Spain ..... G31  
RO\_A Romania ..... G20  
RO\_B Romania ..... G30  
RO\_C Romania ..... G31  
IE\_A Ireland ..... G20

IE\_C Ireland ..... G31  
GB\_A United Kingdom ... G20  
GB\_C United Kingdom ... G31  
BE\_A Belgium ..... G20  
BE\_D Belgium ..... G25  
BE\_C Belgium ..... G31  
HU\_A Hungary ..... G20  
HU\_E Hungary ..... G25.1  
HU\_B Hungary ..... G30  
HU\_C Hungary ..... G31  
FR\_A France ..... G20  
FR\_D France ..... G25  
FR\_C France ..... G31  
PL\_A Poland ..... G20  
PL\_F Poland ..... G2.350  
PL\_B Poland ..... G30  
PL\_C Poland ..... G31  
PT\_A Portugal ..... G20  
PT\_C Portugal ..... G31  
HR\_A Croatia ..... G20  
HR\_B Croatia ..... G30  
HR\_C Croatia ..... G31  
SI\_A Slovenia ..... G20  
SI\_B Slovenia ..... G30  
SI\_C Slovenia ..... G31  
BG\_A Bulgaria ..... G20  
BG\_B Bulgaria ..... G30  
BG\_C Bulgaria ..... G31  
MT\_B Malta ..... G30  
MT\_C Malta ..... G31  
DK\_A Denmark ..... G20  
DK\_B Denmark ..... G30  
DK\_C Denmark ..... G31  
SK\_A Slovakia ..... G20  
SK\_C Slovakia ..... G31  
EE\_A Estonia ..... G20  
EE\_B Estonia ..... G30  
EE\_C Estonia ..... G31  
NL\_D Netherlands ..... G25  
NL\_B Netherlands ..... G30  
NL\_C Netherlands ..... G31  
CZ\_A Czech Rep. .... G20  
CZ\_B Czech Rep. .... G30  
CZ\_C Czech Rep. .... G31  
SE\_A Sweden ..... G20  
SE\_B Sweden ..... G30  
SE\_C Sweden ..... G31  
NO\_A Norway ..... G20  
NO\_B Norway ..... G30  
NO\_C Norway ..... G31  
LV\_A Latvia ..... G20  
LT\_A Lithuania ..... G20  
LT\_B Lithuania ..... G30  
LT\_C Lithuania ..... G31

FI\_A Finland ..... G20  
FI\_B Finland ..... G30  
FI\_C Finland ..... G31  
GR\_A Greece ..... G20  
GR\_B Greece ..... G30  
GR\_C Greece ..... G31  
DE\_A Germany ..... G20  
DE\_D Germany ..... G25  
DE\_B Germany ..... G30  
DE\_C Germany ..... G31  
LU\_A Luxembourg ..... G20  
LU\_D Luxembourg ..... G25  
LU\_C Luxembourg ..... G31  
CY\_B Cyprus ..... G30  
CY\_C Cyprus ..... G31  
IS\_C Iceland ..... G31  
AT\_A Austria ..... G20  
AT\_B Austria ..... G30  
AT\_C Austria ..... G31  
TR\_A Turkey ..... G20  
TR\_B Turkey ..... G30  
TR\_C Turkey ..... G31  
CH\_A Switzerland ..... G20  
CH\_B Switzerland ..... G30  
CH\_C Switzerland ..... G31  
RU\_A Russia ..... G20  
RU\_B Russia ..... G30  
RU\_C Russia ..... G31  
AL\_A Albania ..... G20  
AL\_B Albania ..... G30  
AL\_C Albania ..... G31  
MK\_A Macedonia ..... G20  
MK\_B Macedonia ..... G30  
MK\_C Macedonia ..... G31

### H: Protection for low outdoor temperature

S: Without protection  
A: Freeze protection OAT lower than -10°C  
B: Freeze protection OAT lower than -14°C  
C: Freeze protection OAT lower than -10°C + spring shut-off dampers  
D: Freeze protection OAT lower than -14°C + spring shut-off dampers

### I: Insulation

00S: Without insulation Euroclass A2-s1, d0 (M0)  
00M: With insulation Euroclass A2-s1, d0 (M0)

### J: Special height

000: Without special height  
001: Extra height +170 mm

### K: Special manufacturing

00: Unused

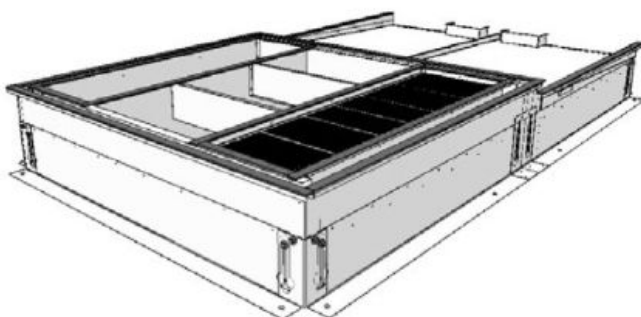

Roof curb without gas burner

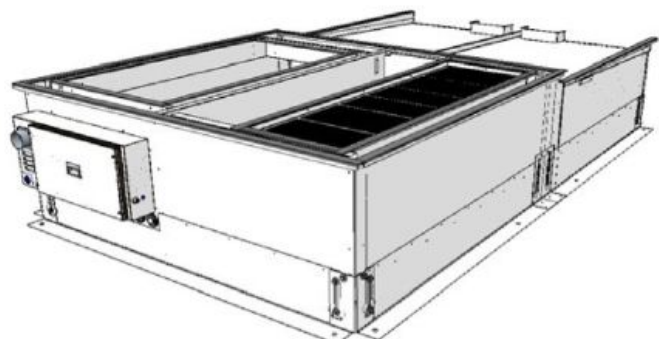

Roof curb with gas burner



## R-454B: THE BEST SOLUTION FOR ROOFTOPS

CARRIER offers the best refrigerant choice according to applications, conditions and technologies.



**CO<sub>2</sub> FOOTPRINT  
REDUCED BY UP TO 80%**

R-454B is currently the ideal refrigeration solution for rooftops. By using R-454B refrigerants, Carrier has reduced the carbon footprint of its version with R-410A by an astonishing 80%.

R-454B is also the right choice economically, reducing the locally imposed tax burden on HFCs based on the CO<sub>2</sub> impact.

The impact of an air conditioning system on global warming of the planet is in large part caused by CO<sub>2</sub> emissions released into the atmosphere when the electricity required to power the unit is produced (**indirect effect**) and in small part by CO<sub>2</sub> emissions linked to uncontrolled emissions of refrigerant with global warming potential into the atmosphere (**direct effect**).

### Direct effect. Lower environmental impact ⇒ -80% compared to R-410A

- R-454B has zero Ozone Depletion Potential (ODP).
- The Global Warming Potential (GWP) of R-454B is 466, i.e. approximately one third of that of R-410A (GWP 2088), and 30% lower than R-32 (GWP 675).
- The 50FF/FC R-454B cooling charge is reduced by 10% compared to the version using R-410A\*
- The carbon footprint of the 50FF/FC R-454B is therefore 420 (466 x 0.9), i.e. 88% lower than the version using R-410A (2088 x 1).

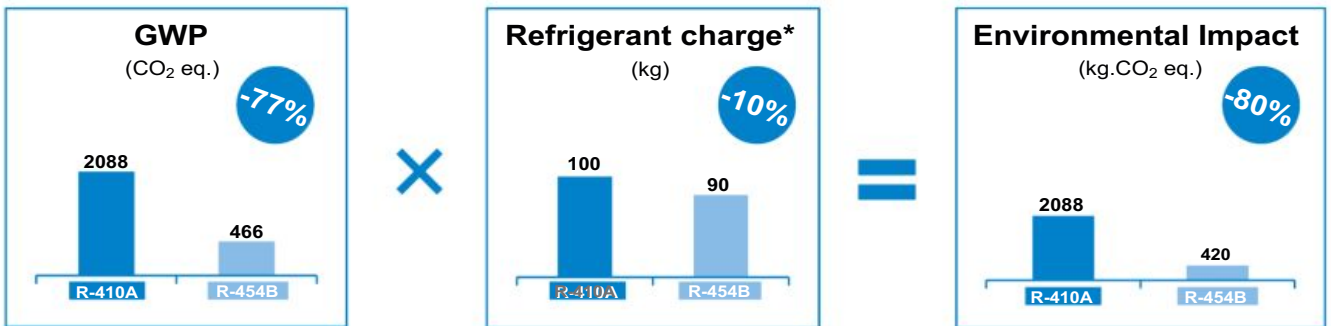

### Indirect effect. Lower environmental impact ⇒ -3% compared to the already astonishing low consumption in 50FF/FC R-410A



**SEER up to +3% (\*)**: Up to 42% savings vs ErP2021  
**SCOP up to +3% (\*)**: Up to 10% savings vs ErP2021  
 (\*) over the already outstanding performance in 50FF/FC R-410A

The seasonal efficiency of 50FF/FC R-454B is higher than the already outstanding performance in 50FF/FC R-410A.

The savings vs Ecodesign requirements go up to 42% in cooling and 10% in heating with 50FF/FC R-454B.

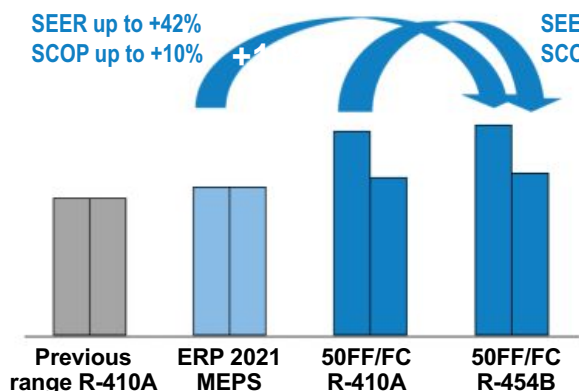

This performance is the result of the optimize and high quality components rigorously selected:

- R-454B refrigerant with high energy performance.
- New generation of scroll compressors, optimized for R-454B refrigerant, in tandem configuration for high performance in partial load.
- Electronic expansion valves.
- "50FC" control optimizing performance and energy consumption.
- Outdoor EC fans for high efficiency and low noise level.
- Indoor EC plug-fans with pressure transducer.

R-454B is an A2L classified refrigerant thanks to its low flammability.

- The service tools must be certified for A2L refrigerants in accordance with standard ISO 817 or EN378.
- Service technicians must be qualified for brazing components on PED 3 fluid units.

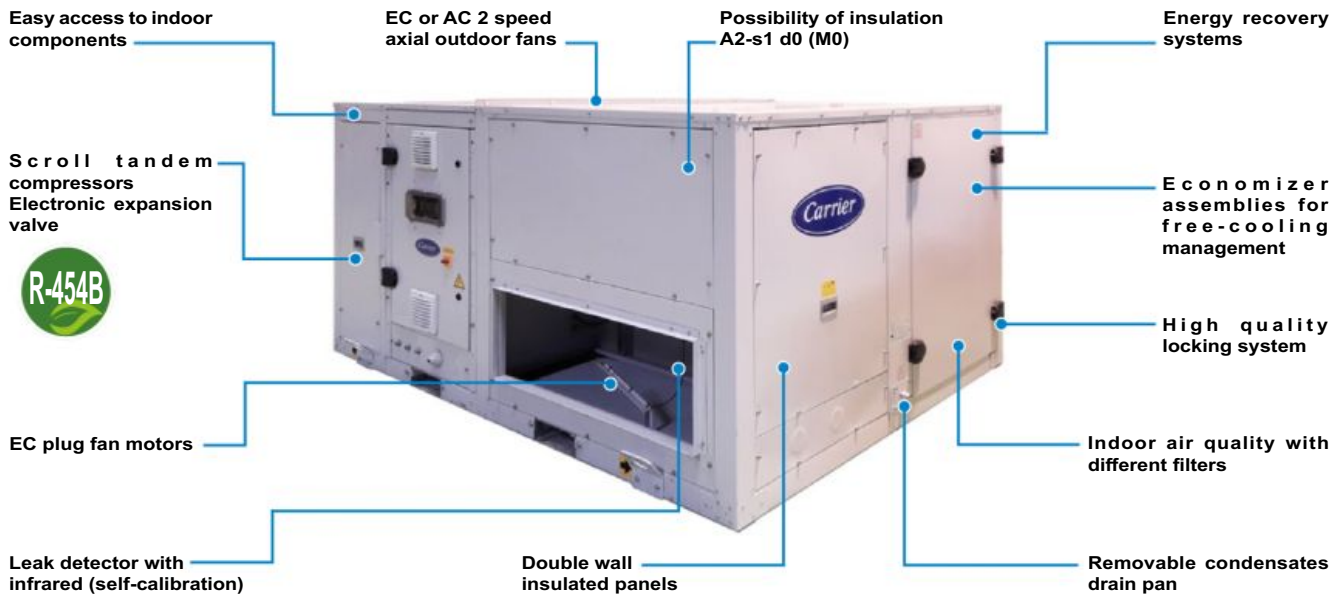

## UNIT COMPONENTS

### Casing

- New self-supporting frame that allow the transport without the need for a wooden pallet.
- Possibility of transport of two stacked units. Only units with electronic outdoor fans (included as standard).
- Casing made of galvanised steel metal. Most parts protected with polyester paint, white colour RAL 7035.
- Removable panels for easy access to all components: electrical cabinet, compressors, fans, filters, etc.

### Outdoor circuit

- Coil with copper pipes and aluminium fins.
  - EC electronic axial fan(s) which adapt the rotation speed to the installation's requirements, thereby reducing electricity consumption, the sound level at partial charge and improving the unit's average seasonal efficiency.
- The cover with the motor fan(s) may be lifted to access the inside of the outdoor circuit.

### Indoor circuit

- Thermal and acoustic insulation, in double wall panels and registers, with Euroclass A2-s1, d0 (M0) fire classification.
  - Coil with copper pipes and aluminium fins.
  - EC electronic supply plug-fans with variable control speed and flow rate controller.
- The fans are factory configured with nominal air flow. Consult for any special configuration.
- Reusable gravimetric air filters G4, mounted on a frame. Dual locking system mounted on the access panel to filters.
  - Isolated pan of condensate drainage sloping down towards the drain. This pan is removable for easy cleaning.

### Cooling circuit

- Hermetic scroll-type compressors in tandem design, with intermediate discharge valve, that improves the management of stages and the part load efficiencies,

assembled over antivibration mounts. Relay for phase-sequence monitoring and phase loss protection.

- Crankcase heater.
- Electronic expansion valve(s).
- Four-way cycle reversing valve(s) (heat pump units).
- Acid-resistant filter(s) dryer.
- Cooling design with:
  - 1-air volume: models 50FC 020 to 047 and models 50FF 020 to 093.
  - 2-air volumes: models 50FC 052 to 093.

### Protections

- High pressure pressostat(s).
  - High and low pressure transducers.
  - Refrigerant leak control (by low-pressure alarm).
  - Due to the A2L category of refrigerant R-454B (lightly flammable), it requires the installation of a refrigerant leak detector. This detector uses infrared instead of semiconductor technology with no need of calibration (self-calibration), with very fast time response, and high lifetime.
- The detector is installed on a panel next to the supply fans of the indoor circuit. This position ensures the correct reading of the gas concentration in the indoor coil.
- If the unit is connected to a BMS monitoring system, the electronic control is prepared to send an alarm signal in case of leakage detection.
- Note: These units are designed to be installed outdoors in a well ventilated area, but a second leak detector can be installed in the outdoor circuit if in any case it is considered necessary. Available upon request.
- Compressor discharge temperature control.
  - Main door switch.
  - Protection for power lines of compressors with manual motor starters and power lines of fan motors with magnetothermic switches. These devices provide protection against overload, short circuit, phase failure and undervoltage.
  - Automatic switch in the control circuit.

## UNIT COMPONENTS

### Electrical cabinet

- Complete and fully wired electrical cabinet. Insulated access door to prevent condensation. Forced ventilation of the electrical cabinet. Protection IP54.
- Numeration of wired and identification of components in the electrical cabinet. It permits easy tracing and diagnostics.
- Hinges + quarter-turn latches on the removable access doors.
- Electrical power supply with neutral.
- Main ground connection.
- Compressor and fan motor contacts.

### "50FC" electronic control

The "50FC" control consist of a control board, sensors, a graphic terminal and a user terminal (optional).

This system includes a RS485 field-bus to manage additional components such as: expansion modules and boards, plug-fans, probes of temperature or relative humidity of the ambient air, leak detectors, energy meters, etc.

This board also integrates two communication ports that allow connection with a centralized technical management system such as BOSS and BOSS mini. A BMS port for Modbus RTU protocol and an Ethernet port for Modbus TCP/IP protocol.

A communication card (optional) can also be connected to the board for the following protocols: BACnet™ MSTP, BACnet™ Ethernet, Modbus RTU, Konnex, TCP/IP, SNMP V1-2-3, FTP y HTTP.

The "50FC" control enables unit integration with our local supervision solutions: pCO Web (1 unit), BOSS mini (50 units) and BOSS (300 units), as well as with the remote solution: ABOUND HVAC Performance.

With this control, it is also possible to connect to a shared network (SHRD) for a maximum of 15 units, with one unit configured as "Master" and the other units as "Slaves". This network allows the exchange of data and information between the units, and depending on the conditions of the installation, it can share the reading of some probes installed on the unit configured as "Master", temperature setpoints, and operating mode. It is also possible to configure one unit as a "Backup", for activation in case of malfunction of the other unit.

- The main functions of this control are:
  - Selection of setpoint and operating mode: HEATING / COOLING / AUTO / VENTILATION.
  - Continuous control of the operating parameters.
  - Display of the values measured by the sensors.
  - Compressors cycles.
  - Defrosting management.
  - Control of the supply air temperature.
  - All-seasons operation via the condensation and evaporation pressure control.
- The management of the unit in cooling mode is based on the principle of a high floating pressure. The condensation pressure setpoint is continually calculated depending on the outdoor temperature. This pressure is regulated by adjusting the air flow on the outdoor fans.
- Setpoint compensation based on the outdoor temperature.
- Hourly and weekly schedule.
- Fire protection.
- Diagnosis of faults and general alarm.

- Management of all the optional components available for the unit: economizer, Backup heating, CO<sub>2</sub> air quality sensor, energy recovery,...

### User interfaces

#### Graphic terminal

This terminal, fitted as standard on the electrical cabinet, is very easy to use. It provides detailed explanations of control in easy to understand English. No decoding is required.

Only 6, large, easy-to-use buttons are required to maneuver through the entire menus.

- This terminal is used to:
  - Carry out initial programming of the unit.
  - Modify operating parameters.
  - Switch the unit ON / OFF.
  - Select the operating mode and adjust the setpoints.
  - Display the variables controlled and sensor values measured.
  - Display the current alarms and their historical record.



Note: multiple units can share a single terminal, if they are integrated into a pLAN local network (for up to 15 units).

#### User terminal (optional)

This terminal can be installed on the electrical cabinet, instead of the graphic terminal. In this case, the remote connection of the graphic terminal is possible.

- This terminal is used to:
  - Switch the unit ON / OFF.
  - Select the operating mode and adjust the setpoints.
  - Display the installation's temperatures and humidity, outdoor temperature, supply air temperature, CO<sub>2</sub> sensor and opening of the outdoor damper.
  - Display alarms codes.



#### Touch panel (optional)

With the same functions as the graphic terminal, the 4.3 inch touchscreen panel makes interaction between the user and the unit much easier by simplifying navigation between the various screens.





## ECODESIGN REGULATIONS

### New metrics because seasonal efficiency matters

With all new buildings expected to be close to zero energy, calculations of the energy efficiency of buildings require accurate indicators of the efficiency of their equipment. These indicators must be representative of actual operations throughout the year, measuring the performance of equipment on a seasonal basis.

**EER & COP belong to the past.** Now, and in the future, the focus is on seasonal efficiency. With a broad new products range, Carrier is fully engaged to take up the challenge of energy efficiency.

**Compliance with the Ecodesign regulations therefore involves the use of new, more meaningful seasonal efficiency metrics.** The Seasonal Energy Efficiency Ratio (SEER), and Seasonal Coefficient of Performance (SCOP) all ensure precise evaluation of the energy actually consumed by rooftops, by including seasonal variations in their measurements. Previous metrics (EER & COP) measured operations only at a single point, at full thermal load, and were therefore less representative of consumption over entire heating and cooling seasons.



### $\text{Eta}_s (\eta_s)$ :

In order to compare the energy efficiency of products using different sources of energy, the Ecodesign regulation introduces a new measurement expressed in primary energy:  $\eta_s$  cool is the equivalent of SEER for cooling applications and  $\eta_s$  heat is the equivalent of SCOP for space heating.

These new seasonal performance metrics are now the key indicator used for rooftops, in all applications.

They are calculated according to technical standard **EN-14825-2022** and compliance is mandatory for a product to obtain CE marking.

### Confort cooling

#### SEER - Seasonal Energy Efficiency Ratio



SEER measures the seasonal energy efficiency of rooftops by calculating the ratio between annual cooling demand and annual energy input. It takes into account the energy efficiency achieved for each outdoor temperature weighted by the number of hours observed for each of these temperatures, using actual climate data.

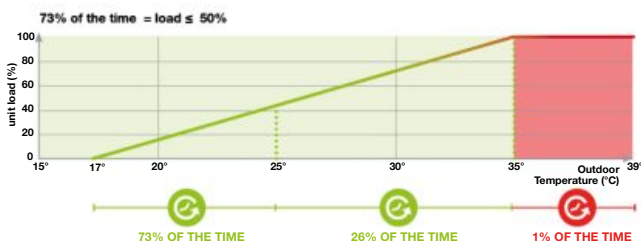

SEER is a new way of measuring the true energy efficiency of rooftops for cooling over an entire year.

This new indicator gives a more realistic indication of the real energy efficiency and environmental impact of a cooling system.

#### Efficiency requirements

Regulation 2016/2281 sets seasonal energy efficiency in  $\text{Eta}_s$  cool ( $\eta_s$  cool). This expresses SEER in terms of primary energy and so makes it possible to compare the energy efficiency of units using different energy sources.

Minimum  $\eta_s$ SC (SEER) according regulation (EU) 2016/2281:

From 01/2018. Tier1		From 01/2021. Tier2	
$\eta_s$ SC %	SEER	$\eta_s$ SC %	SEER
117	3,00	138	3,53

### Space heating

#### SCOP – Seasonal Coefficient of Performance



SCOP measures the seasonal energy efficiency of rooftops by calculating the ratio between annual heating demand and annual energy input. It takes into account the energy efficiency achieved at each outdoor temperature of an average climate weighted by the number of hours observed for each of these temperatures.

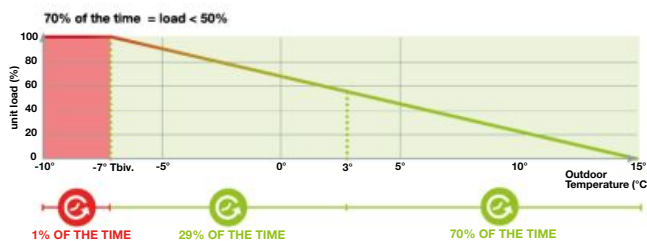

SCOP is a new way of measuring the true energy efficiency in heating mode over an entire year.

This new indicator gives a more realistic indication of the real energy efficiency and environmental impact of a heating system.

#### Efficiency requirements

Regulation 2016/2281 sets seasonal energy efficiency in  $\text{Eta}_s$  heat ( $\eta_s$  heat). This expresses SCOP in terms of primary energy and so makes it possible to compare the energy efficiency of units using different energy sources.

Minimum  $\eta_s$ SH (SCOP) according regulation (EU) 2016/2281:

From 01/2018. Tier1		From 01/2021. Tier2	
$\eta_s$ SH %	SCOP	$\eta_s$ SH %	SCOP
115	2,95	125	3,20

As stipulated in Annex II paragraph 5 of Regulation 2016/2281, the technical data sheets (TDS) for CARRIER units are available at <http://www.ecodesign.hvac.carrier.com/>

## PHYSICAL DATA WITH R-454B REFRIGERANT (EN-14511-2022)

50FF		020	028	037	040	045	047	052	058	062	070	074	086	093	
<b>Cooling capacities</b>															
Cooling capacity (1)	kW	22,5	28,0	33,9	36,4	42,0	44,5	49,3	53,7	59,3	68,0	72,1	80,0	89,5	
Power input (3)	kW	6,90	8,86	10,1	11,4	13,0	13,9	15,4	17,0	19,7	21,2	22,6	26,0	29,7	
EER performance		3,26	3,16	3,36	3,20	3,23	3,21	3,21	3,15	3,01	3,21	3,19	3,08	3,01	
SEER		5,06	5,06	4,75	4,58	4,48	4,48	4,86	4,79	4,71	4,69	4,71	4,52	4,45	
ηs		199%	199%	187%	180%	176%	176%	192%	189%	185%	185%	185%	178%	175%	
<b>Outdoor circuit fan</b>															
Electronic axial fan															
Nominal air flow	m <sup>3</sup> /h	9.000	14.500	17.000	17.000	17.000	17.750	31.000	31.000	31.000	33.000	33.000	34.500	35.000	
Available static pressure	mm.w.c	5													
Number / Diameter	mm	1 / 630			1 / 800				2 / 800						
Ingress protection rating		IP54			IP55				IP55						
Maximum speed	r.p.m.	1.140			1.020				1.020						
Motor output	kW	0,9			2,6				2 x 2,6						
Maximum absorbed current	A	1,6			3,9				7,8						
<b>Indoor circuit supply fan</b>															
Electronic plug-fan															
Nominal air flow	m <sup>3</sup> /h	5.100	6.500	8.500	8.750	9.000	9.000	12.000	12.500	12.500	15.500	15.500	16.000	16.000	
Available static pressure	mm.w.c	12	12	12	15	15	15	20	20	20	20	20	20	25	
Number / Diameter	mm	1 / 500			1 / 500				2 / 500						
Speed	r.p.m.	1.800			1.855				1.800						
Motor output	kW	1 x 3,1			1 x 3,1				2 x 3,1						
Maximum absorbed current	A	4,7			4,8				9,4						
<b>Compressor</b>															
Scroll															
No. compressors / stages / circuits		2 / 2 / 1						2 / 2 / 1							
Oil type		Copeland 3MAF 32cST, Danfoss POE 160SZ, ICI Emkarate RL 32CF, Mobil EAL Artic 22CC													
Volume of oil	l	2 x 1,24	2 x 1,24	2 x 1,24	2 x 1,72	2 x 1,72	2 x 1,72	2 x 3,0	2 x 3,3	2 x 3,3	2 x 3,3	2 x 3,3	2 x 3,3	2 x 3,6	
<b>Electrical characteristics</b>															
Mains voltage		400 V / III ph / 50 Hz (±10%)													
Power supply		3 Wires + Ground + Neutral													
Maximum absorbed current	A	21,2	27,5	26,8	29,6	34,7	34,9	50,3	55,6	58,8	58,9	65,1	70,1	77,6	
<b>Refrigerant</b>															
R-454B															
Global warming potential (4)	GWP	466													
Charge	kg	7,2	7,5	9,9	9,9	10,2	10,4	10,2	10,4	10,6	16,1	16,3	16,3	16,5	
Environment impact	tCO <sub>2</sub> eq	3,4	3,5	4,6	4,6	4,8	4,8	4,8	4,8	4,9	7,5	7,6	7,6	7,7	
<b>Weight</b>															
B1 assembly	kg	594	617	699	698	704	701	914	929	936	1.035	1.059	1.057	1.078	

(1) Cooling capacity calculated in accordance with the EN-14511-2022 standard given for indoor temperature conditions 27°C, 19°C WB and 35°C outdoor temperature.

(3) Total power input by compressors and motorised fans under nominal conditions, calculated in accordance with the EN-14511-2022 standard.

(4) Climatic warming potential of a kilogram of fluorinated greenhouse gas in relation to a kilogram of carbon dioxide over a period of 100 years.

### Compliance

- Machinery Directive 2006/42/EC (MD)
- Electromagnetic Compatibility Directive 2014/30/EU (EMC)
- Pressure Equipment Directive 2014/68/EU (Category 2) (PED)
- RoHS Directive 2011/65/EU (RoHS)
- Eco-design Directive 2009/125/EC (ECO-DESIGN)
- Energy Labelling Directive 2017/1369/EU (ECO-LABELLING)
- Harmonised Standard: EN 378-2:2012 (Refrigerating systems and heat pumps - Safety and environmental requirements).



Eurovent  
certified  
values



**PHYSICAL DATA WITH R-454B REFRIGERANT (EN-14511-2022)**

50FC		020	028	037	040	045	047	052	058	062	070	074	086	093		
<b>Cooling capacities</b>																
Cooling capacity (1)	kW	22,6	28,2	34,0	36,5	42,2	44,6	53,9	58,6	61,2	69,5	71,3	80,7	91,5		
Power input (3)	kW	6,95	8,92	10,1	11,4	13,1	13,9	16,4	18,3	19,2	20,9	22,3	25,2	28,3		
EER performance		3,25	3,16	3,36	3,19	3,23	3,21	3,28	3,21	3,18	3,32	3,20	3,20	3,23		
SEER		5,07	5,07	4,75	4,59	4,49	4,49	4,94	4,96	5,01	4,81	4,68	4,58	4,61		
$\eta_s$		200%	200%	187%	181%	177%	177%	194%	195%	198%	190%	184%	180%	181%		
<b>Heating capacities</b>																
Heating capacity (2)	kW	22,1	28,0	33,3	35,9	41,8	44,6	51,2	56,3	59,1	68,1	70,5	79,8	89,8		
Power input (3)	kW	5,73	7,87	8,90	9,76	11,7	12,7	14,2	15,8	16,6	18,5	19,5	22,3	25,4		
COP performance		3,86	3,56	3,74	3,68	3,57	3,50	3,60	3,57	3,56	3,68	3,62	3,58	3,54		
SCOP		3,60	3,55	3,54	3,56	3,59	3,58	3,65	3,80	3,56	3,64	3,64	3,70	3,66		
$\eta_s$		141%	139%	139%	139%	141%	140%	143%	149%	139%	142%	143%	145%	143%		
<b>Outdoor circuit fan</b>																
Electronic axial fan																
Nominal air flow	m <sup>3</sup> /h	9.000	14.500	17.000	17.000	17.000	17.750	31.000	31.000	31.000	33.000	33.000	34.500	35.000		
Available static pressure	mm.w.c	5														
Number / Diameter	mm	1 / 630			1 / 800				2 / 800							
Ingress protection rating		IP54			IP55				IP55							
Maximum speed	r.p.m.	1.140			1.020				1.020							
Motor output	kW	0,9			2,6				2 x 2,6							
Maximum absorbed current	A	1,6			3,9				7,8							
<b>Indoor circuit supply fan</b>																
Electronic plug-fan																
Nominal air flow	m <sup>3</sup> /h	5.100	6.500	8.500	8.750	9.000	9.000	12.000	12.500	12.500	15.500	15.500	16.000	16.000		
Available static pressure	mm.w.c	12	12	12	15	15	15	20	20	20	20	20	20	25		
Number / Diameter	mm	1 / 500			1 / 500				2 / 500				2 / 500			
Speed	r.p.m.	1.800			1.855				1.800				1.855			
Motor output	kW	1 x 3,1			1 x 3,1				2 x 3,1				2 x 3,1			
Maximum absorbed current	A	4,7			4,8				9,4				9,6			
<b>Compressor</b>																
Scroll																
No. compressors / stages / circuits		2 / 2 / 1						4 / 4 / 2								
Oil type		Copeland 3MAF 32cST, Danfoss POE 160SZ, ICI Emkarate RL 32CF, Mobil EAL Artic 22CC														
Volume of oil	l	2 x 1,24	2 x 1,24	2 x 1,24	2 x 1,72	2 x 1,72	2 x 1,72	4 x 1,24	4 x 1,24	4 x 1,24	4 x 1,24	4 x 1,72	4 x 1,72	4 x 1,72		
<b>Electrical characteristics</b>																
Mains voltage		400 V / III ph / 50 Hz ( $\pm 10\%$ )														
Power supply		3 Wires + Ground + Neutral														
Maximum absorbed current	A	21,2	27,5	26,8	29,6	34,7	34,9	51,0	55,0	54,2	53,4	59,0	64,3	69,8		
<b>Refrigerant</b>																
R-454B																
Global warming potential (4)	GWP	466														
Charge	kg	7,2	7,5	9,9	9,9	10,2	10,4	2 x 5,7	2 x 5,8	2 x 5,9	2 x 9,0	2 x 9,1	2 x 9,1	2 x 9,2		
Environment impact	tCO <sub>2</sub> eq	3,4	3,5	4,6	4,6	4,7	4,9	5,3	5,4	5,5	8,4	8,5	8,5	8,6		
<b>Weight</b>																
B1 assembly	kg	594	617	699	698	704	701	986	986	1.004	1.146	1.146	1.135	1.160		

- (1) Cooling capacity calculated in accordance with the EN-14511-2022 standard given for indoor temperature conditions 27°C, 19°C WB and 35°C outdoor temperature.
- (2) Heating capacity calculated in accordance with the EN-14511-2022 standard given for indoor temperature conditions 20°C and 6°C WB outdoor temperature.
- (3) Total power input by compressors and motorised fans under nominal conditions, calculated in accordance with the EN-14511-2022 standard.
- (4) Climatic warming potential of a kilogram of fluorinated greenhouse gas in relation to a kilogram of carbon dioxide over a period of 100 years.

**Compliance**

- Machinery Directive 2006/42/EC (MD)
- Electromagnetic Compatibility Directive 2014/30/EU (EMC)
- Pressure Equipment Directive 2014/68/EU (Category 2) (PED)
- RoHS Directive 2011/65/EU (RoHS)
- Eco-design Directive 2009/125/EC (ECO-DESIGN)
- Energy Labelling Directive 2017/1369/EU (ECO-LABELLING)
- Harmonised Standard: EN 378-2:2012 (Refrigerating systems and heat pumps - Safety and environmental requirements).



Eurovent certified values

## OPERATING LIMITS

Inlet air conditions		Cooling	
		50FF	50FC
Indoor coil	Minimum temperature	9,7°C WB	
	Maximum temperature	24°C WB	
Outdoor coil	Minimum temperature	-10°C (1)	
	Maximum temperature	52°C	48°C

Inlet air conditions		Heating	
		50FC	
Indoor coil	Minimum temperature	10°C	
	Maximum temperature	27°C	
Outdoor coil	Minimum temperature	-15°C WB (2)	
	Maximum temperature	15°C WB	

- (1) If the condensation pressure control (standard) is disabled, the minimum temperature will be 12°C.  
 (2) When the outdoor temperature is usually below 5°C WB, the installation of a support element is recommended.

## SOUND LEVELS dB(A)

### Sound power level (LW)

50FF/FC	020	028	037	040	045	047	052	058	062	070	074	086	093
63 Hz	55,2	60,8	61,4	60,9	61,3	63,1	64,3	64,5	64,9	64,8	64,6	64,6	65,3
125 Hz	64,2	66,7	68,9	66,1	70,0	71,1	69,6	69,9	71,5	72,4	71,3	71,4	74,0
250 Hz	71,8	74,8	76,1	72,9	76,3	76,4	77,0	77,7	78,9	79,7	78,4	77,9	79,3
500 Hz	70,2	76,7	76,4	76,8	77,1	78,3	79,5	80,1	80,4	79,9	80,1	80,2	80,9
1000 Hz	72,0	76,2	76,3	77,5	77,3	78,2	79,4	79,9	80,2	79,8	80,4	80,6	80,7
2000 Hz	69,7	73,5	74,3	75,3	74,1	75,5	77,0	77,4	77,8	77,7	78,3	78,1	77,7
4000 Hz	62,6	69,2	70,3	70,6	70,4	72,2	73,1	73,4	73,7	73,8	73,9	74,2	74,4
8000 Hz	59,0	63,7	65,5	65,8	65,6	67,5	67,9	68,2	68,6	68,9	69,1	69,4	69,6
Total dB(A)	77,5	82,0	82,5	82,5	83,0	84,0	85,0	85,5	86,0	86,0	86,0	86,0	86,5

### Sound pressure level (LP)

Measurement conditions: in a clear field, measured at a distance of 10 metres, directivity 2 and at 1,5 metres from the ground.

50FF/FC	020	028	037	040	045	047	052	058	062	070	074	086	093
Total dB(A)	45,8	50,3	50,8	50,8	51,3	52,3	53,1	53,7	54,2	54,2	54,1	54,1	54,6

Note: The sound pressure level depends on the installation conditions and, as such, it only indicated as a guide. Values obtained according to the ISO 3744 standard.

## ELECTRICAL CONNECTIONS

No.	50FF/FC	020 to 093	
1	Main power supply	400 III (±10%) 3 Wires + Ground + Neutral	
2	Remote connection of graphic terminal (by default installed on the electrical cabinet) (1)	Telephone cable 6 wires standard (RJ12 connector)	
3	Connection of user terminal (optional) (2)	2 wires for power supply 230V + 1 shielded cable for communication type AGW20 / 22 (1 braided pair + drainwire + shielding)	
4	Remote off/on (optional)	2 wires	
5	General fault signal (opt.) (3)	2 wires	
6	Remote Cooling / Heating (optional upon request)	2 wires	
7	Circulation pump signal for HWC (antifreeze safety) (optional)	1 wire	
8	Ambient sensor	NTC	2 wires
		RS485	5 wires (4)
9	CO <sub>2</sub> air quality sensor (optional)	3 wires	

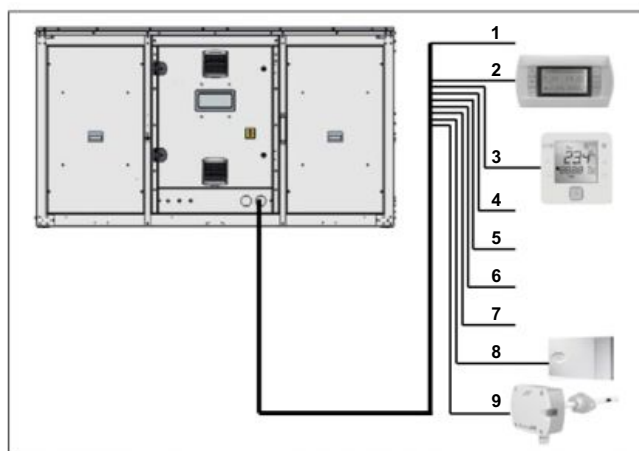

- (1) In this case, it's possible to install the user terminal on the electrical cabinet.
- (2) The power supply of the electrical cabinet (230 V) must be used for terminal power.
- (3) The output for general alarm signal is not compatible with the following options: hot water coil, heat recovery coil, rotary heat exchanger and on/off signal for external humidifier. With these options, possibility of general alarm upon request.
- (4) Up to four RS485 ambient sensors can be connected in series on the field-bus of the control board.

## FACTORY OPTIONS AND ACCESSORIES

Category	Description	Factory installed option	Field installed accessory
Electrical power Flow + Assembly	400 V / 3 ph / 50 (without neutral)	X	
	B2: Economizer, 2 dampers	X	
	BF: 100% fresh air	X	
	B3: Economizer, 3 dampers	X (*)	
	BX: Axial fan in return section	X (*)	
	BP: Plug-fan in return section	X (*)	
	BA: Cooling recovery circuit with plug-fan in return section	X (*)	
	BT: Return top box with plug-fan or centrifugal fan	X	
	BB: Cooling recovery circuit with plug-fan or centrifugal fan in return top box	X	
	BW: Heat recovery wheel module	X (*)	
Coil coating	BL: Return top box with plug-fan or centrifugal fan with heat recovery wheel module (upon request)	X (*)	
	Coils with polyurethane precoated aluminium fins and copper pipes	X	
Heating	INERA® coils with aluminium alloy fins and copper pipes	X	
	Blygold® coating	X	
	Auxiliary hot water coil : Standard or Very low outdoor temperature	X	
Protection low temperature	Auxiliary electrical heaters	X	
	Warm air heater module with gas burner (supplied installed inside a pre-assembly roof curb)		X
	Freeze protection OAT lower than -10°C	X	
Supply fan	Freeze protection OAT lower than -14°C	X	
	Freeze protection OAT lower than -10°C + spring shut-off dampers	X	
	Freeze protection OAT lower than -14°C + spring shut-off dampers	X	
	Indoor plug-fan with nominal available pressure (Aluminum), low pressure or high pressure	X	
Air filtration + droplet eliminator	Droplet eliminator after the indoor air coil	X	X
	Low pressure drop G4 filters	X	X
	G4 filters + M6, F7 or F9 folded filters	X	X
	Low pressure drop G4 filters + F7 or F9 folded filters	X	X
	Double stage of folded filters: M6+F7, M6+F9, F7+F9 or F9+F9	X	X
Outdoor fan	Two-speed direct-driven axial fans	X	
Insulation	Thermal and acoustic insulation, Euroclass A2-s1, d0 (M0), in ceramic fibre	X	
Indoor circuit	Condensates drain pan in stainless steel	X	X
	Room overpressure management	X	
	Filter fouling detection with differential pressure switch	X	
Outdoor circuit	Fresh air safety grid	X	X
	Outdoor coil protection grid	X	X
	Droplet eliminator at the fresh air intake	X	X
	Antivibration mounts made of rubber	X	X
Heat recovery wheel	Selection of the heat recovery wheel (BW assembly): wheel materials, channel cross section, air filtration and type of speed control	X	
Extra heating	Heat recovery coil	X (*)	
	Preheater (electrical heater) in fresh air, low or nominal power		X
Special applications	Air zoning	X (*)	
	Low return temperature application	X	
	Low return temperature application + Air zoning	X (*)	
	100% fresh air (without or with air zoning)	X	
Sensors	NTC ambient temperature sensor on the control board or 1 to 4 sensors with RS485 comm.	X	X
	Ambient temperature + humidity sensor with RS485 communication. Up to four sensors	X	X
	CO <sub>2</sub> sensor: environment or ducted installation or installed on a shared network (SHRD)	X	X
	Smoke detection control unit in accordance with the NF S 61-961 standard	X	X
Economizer + Outd. humidity	Economizer management: thermal, enthalpic or thermoenthalpic	X	X
	Outdoor air humidity sensor: supplied with the unit or installed on a shared network (SHRD)	X	X
Terminal + Unit communication	Graphic terminal installed in the electrical cabinet + User terminal remote up to 100 m	X	X
	Graphic terminal installed in the electrical cabinet + Graphic terminal remote up to 200 m	X	X
	User terminal installed in the electrical cabinet	X	X
	User terminal installed in the electrical cabinet + Graphic terminal remote up to 200 m	X	X
	Touch panel in the electrical cabinet	X	X
	Touch panel in the cabinet + Graphic terminal remote up to 200 m	X	X
	Touch panel in the cabinet + User terminal remote up to 100 m	X	X
	Unit configuration: stand-alone, master or slave	X	X
	Communication cards: Ethernet PCoWeb; Ethernet BACnetTM; RS485 BACnetTM; RS485 Konnex; RS485 Modbus	X	X
	Miscellaneous item 1	Management of an humidifier with on-off or proportional control	X
Electrical energy meter		X	
Cooling capacity and electrical energy meter		X	
Miscellaneous item 2	Compressor soft-starter	X	
	Varnish protection for components on the electrical cabinet: control board, cards and terminals	X	
	High performance phase monitoring relay	X	
Return fan	Centrifugal return fan (BB and BT assemblies). 9 combinations of air flow and available pressure	X	
	Return plug-fan with nominal pressure (Aluminium)	X	
Air direction	There are 9 combinations in the direction of airflow with: - Supply: lower, lateral and upper - Return: lower, lateral and upper	X	
Roof curb	Pre-assembly roof curbs with adjustable height		X
	Adaptation roof curbs for replacing units on site		X

(\*) Part of this option must be installed on-site.

## FACTORY OPTIONS AND ACCESSORIES

### Assembly + Indoor air flow direction

<p><b>B1 assembly</b></p> <p>Standard</p>	<p><b>B2 assembly</b></p> <p>Economizer, 2 dampers: fresh air damper interlocked with return damper</p>	<p><b>BF assembly</b></p> <p>100% fresh air</p>								
<p><b>B3 assembly</b></p> <p>Economizer, 3 dampers: fresh air damper and exhaust air damper</p>	<p><b>BX assembly</b></p> <p>Axial return fan</p>	<p><b>BP assembly</b></p> <p>Plug-fan in return section</p>								
<p><b>BA assembly</b></p> <p>Plug-fan in return section + Cooling recovery circuit (active recovery)</p>	<p><b>BT assembly</b></p> <p>Return top box with plug-fan or centrifugal fan</p>	<p><b>BB assembly</b></p> <p>Return top box with plug-fan or centrifugal fan + Cooling recovery circuit (active recovery)</p>								
<p><b>BW assembly</b></p> <p>Plug-fan in return section + Heat recovery wheel module (passive recovery)</p>	<p><b>BL assembly (upon request)</b></p> <p>Return top box with plug-fan + Heat recovery wheel module (passive recovery)</p>	<p><b>Legend</b></p> <table border="1"> <tr> <td><b>S</b> Lower air supply</td> <td><b>R</b> Lower air return</td> </tr> <tr> <td><b>S'</b> Lateral air supply</td> <td><b>R'</b> Lateral air return</td> </tr> <tr> <td><b>S''</b> Upper air supply</td> <td><b>R''</b> Upper air return</td> </tr> <tr> <td><b>F</b> Fresh air intake</td> <td><b>E</b> Exhaust air outlet</td> </tr> </table> <p>Note: only one of the three possible options (lower, lateral or upper) can be selected for both, supply and return.</p>	<b>S</b> Lower air supply	<b>R</b> Lower air return	<b>S'</b> Lateral air supply	<b>R'</b> Lateral air return	<b>S''</b> Upper air supply	<b>R''</b> Upper air return	<b>F</b> Fresh air intake	<b>E</b> Exhaust air outlet
<b>S</b> Lower air supply	<b>R</b> Lower air return									
<b>S'</b> Lateral air supply	<b>R'</b> Lateral air return									
<b>S''</b> Upper air supply	<b>R''</b> Upper air return									
<b>F</b> Fresh air intake	<b>E</b> Exhaust air outlet									

Indoor airflow direction		
<b>0</b> Lower supply and lower return	<b>3</b> Lateral supply and lateral return	<b>6</b> Upper supply and lateral return
<b>1</b> Lateral supply and lower return	<b>4</b> Upper supply and lower return	<b>7</b> Lower supply and upper return
<b>2</b> Lower supply and lateral return	<b>5</b> Lateral supply and upper return	<b>8</b> Upper supply and upper return

## FACTORY OPTIONS AND ACCESSORIES

### Air pressure control in different assemblies

In case of assemblies with fresh air (ventilation) but without extraction air, overpressure will be generated in the building, higher with higher fresh air ratios or in free-cooling mode. It will not generate any issue in buildings with low air tightness and/or with doors frequently opened, but we should prevent in other applications. In assemblies with extraction damper and return fans, this overpressure can be completely avoided (pressure balance), or even controlled with a certain value to prevent infiltrations.

**50FF/FC** is the rooftop with the largest offer in airflow configurations to be able to adapt the unit to any kind of application or request. Please, find below comments and recommendations for each assembly.

Assembly	Fresh air and free-cooling	Return fans	Energy recovery (extraction)	Pressure control	Comments and recommendations
B1		No	No	No control required	Only for building with <b>no need of fresh air</b> . Pressure balance by default. Same return and supply airflow.
B2		No	No	No control	Adequate just for buildings with medium or low <b>air tightness</b> and/or doors frequently opened.
B2 + gravity dampers in the building		No	No	High control	Building overpressure is maintained at the same level than pressure drop before the gravity damper. No limitations in the return pressure drop.
B3		No	No	Medium control	Recommended only with <b>low pressure drop in the return ductwork</b> (maximum 50 Pa). The maximum building overpressure is at the same level than pressure drop in the return ductwork.
BA, BB		Yes	Yes, Active recovery	High control	Return and supply EC plug-fan(s) are always supplied with pressure sensor to adjust the airflow. To manage <b>pressure balance</b> , supply and return are configured with same airflow.
BP, BT		Yes	No	Total control	In case <b>overpressure</b> want to be managed (to avoid infiltration), the return airflow need to be lower than the supply. Differences <b>up to 10%</b> can be always being configured. Additional overpressure with airflow differences <b>up to 20%</b> are possible <b>adding the option "overpressure control"</b> (*) which manages fresh and exhaust dampers independently.
BW, BL (upon request)		Yes	Yes, Passive recovery (wheel)	Total control	To maintain overpressure in case of variable fresh air management (with CO <sub>2</sub> sensor option), minimum fresh air ratio need to be configured.

(\*) This overpressure option is not available on BA and BB assemblies because this type of control of the dampers penalizes cooling recovery.

#### Example:

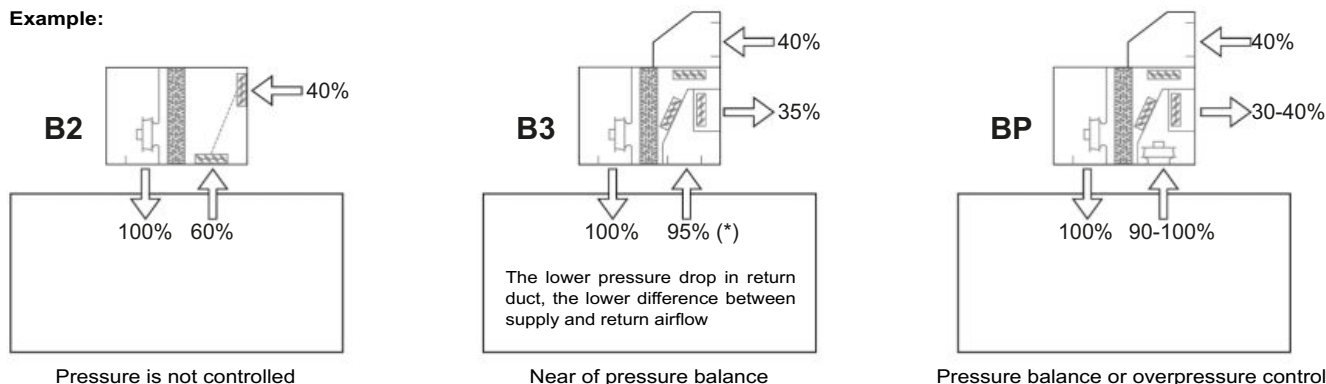



## FACTORY OPTIONS AND ACCESSORIES

### Electrical power

- These units can be supplied for the following power supply voltages:
  - 400 V / 3 ph + N / 50 Hz (standard)
  - 400 V / 3 ph / 50 Hz (optional)

### Coils coating

- Coils with copper pipes and aluminium fins with **polyurethane** coating.  
Level of corrosion protection: basic. This treatment offers a resistance of more than 1000 hours (ASTM B117 NSST).
- Coils with copper pipes and fins of an aluminium alloy **INERA®**.  
Level of corrosion protection: basic - medium. This treatment offers a resistance of more than 1000 hours (ASTM B117 NSST).
- Blygold®** coating.  
Level of corrosion protection: medium. This treatment offers more protection than 11000 hours in salt spray test (ASTM B117 NSST) and 4000 hours in acid salt spray test.

For further detailed information, please contact our Customer Service Department.

Note: These coating can be applied to various coils (outdoor, indoor and hot water coil) according to the combinations available in our "Selection Software".

### Heating

The unit only can incorporate one of these heating elements:

- Warm air heater module with gas burner** with modulating actuator, in accordance with the Gas Directive 2009/142/EC, installed inside a pre-assembly roof curb.  
Condensation boiler with premixing and modulation technology that allows outputs close to 109% with regard to the lower heating value (LCV).

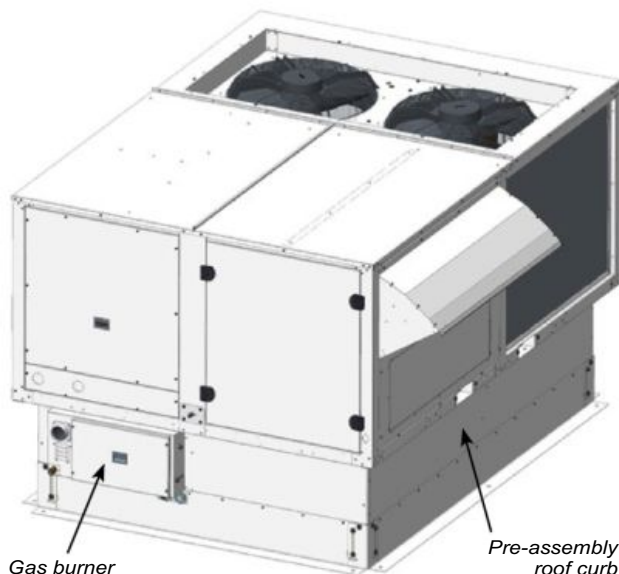

Note: It's recommended to use the filter fouling detector (optional) in units with gas burner.

Up to 3 values of total power available for each model:

50FF/FC	020 to 047	052 to 062	070 to 093
BAF (Low)	PCH020	unavailable	unavailable
BAM (Nominal)	PCH034	PCH065	PCH080
BAS (High)	PCH045	PCH080	PCH105

- Auxiliary electrical heaters**, with two power stages and on/off control, for assembly and connection inside the unit.

Up to 3 values of total power available for each model:

50FF/FC	020 to 028	037 to 047	052 to 093
RAF (Low)	12 kW	12 kW	18 kW
RAM (Nominal)	18 kW	18 kW	27 kW
RAS (High)	unavailable	27 kW	36 kW

- Electrical heaters with proportional control (**upon request**).
  - Auxiliary hot water coil**, with three-way valve and proportional control, for assembly inside the unit.
    - The unit incorporates a freeze protection thermostat.
    - There are two configuration types available:
      - Standard (HAS), with the freeze protection thermostat.
      - Very low outdoor temperature (HAF), with freeze protection technology based on the water temperature. This protection is made up of a circulation pump as well as two sensors inserted in the input and the output of the coil.
- Important: this option is mandatory for an outdoor temperature lower than -20°C WB. Consult for percentages of glycol water above 20%.
- Note: on units with this option, air supply only may be lateral (factory-configured).

### Protection for low outdoor temperature

- Freeze protection OAT lower than -10°C. Mandatory for an outdoor temperature lower than -10°C WB.
  - Electrical heater for protection of the components of the electrical cabinet.
  - Compressor with protection for low temperature.
- Freeze protection OAT lower than -14°C. Mandatory for an outdoor temperature lower than -14°C WB.  
In addition to the options of -10°C, this includes:
  - Reinforced electrical heater for protection of the components of the electrical cabinet.
  - Electrical heater for anti-freeze protection of dampers of the economizer (if applicable).
  - Protective kit of the gas burner for low temperature (if applicable).
- Freeze protection OAT lower than -10°C + spring shut-off dampers in case of a power failure.
- Freeze protection OAT lower than -14°C + spring shut-off dampers in case of a power failure.

### Supply fan

- By default, these units are fitted with plug-fans for a nominal available pressure (N), in Polypropylene.



## FACTORY OPTIONS AND ACCESSORIES

The following fans can optionally be supplied:

- F: Low available pressure: except for models 037, 040, 045, 047, 070 and 074.
- M: Nominal available pressure (Aluminium).
- S: High available pressure.

Note: Aluminium fans are rated A2-s1, d0 (M0) and comply with regulations for public promises in France.

Note: The fans are factory configured with nominal air flow. Consult for any special configuration.

Important: the "Selection Software" will choose the supply fan with lower consumption for the available pressure required.

### Air filtration + Droplet eliminator

Options to improve indoor air quality:

- Different combinations of filters are available:
  - Gravimetric filters G4 with low pressure drop.
  - Gravimetric filters G4 of standard type + folded opacimetric filters M6, F7 or F9.
  - Gravimetric filters G4 with low pressure drop + folded opacimetric filters F7 or F9.
  - Double-stage of folded opacimetric filters (M6+F7, M6+F9, F7+F9 or F9+F9).

Classification of these filters according to the new **ISO 16890 Standard**:

- G4 → ISO Coarse 60%
- M6 → ISO ePM10 70%
- F7 → ISO ePM1 50%
- F9 → ISO ePM1 80%

- Droplet eliminator after the indoor air coil. Recommended in cases where a high moisture content in the air is foreseen or when the air flow is high.

Note: with hot water coil it is not possible to assemble the droplet eliminator.

### Outdoor fan

- Two-speed direct-driven axial fan(s). Watertight motor class F, IP54 and internal thermal protection. Dynamically balanced propellers and outdoor protective grille.

Note: These fans do not allow the transport of two stacked units, as they protrude from the unit cover (+ 275 mm).

### Insulation

- Thermal and acoustic insulation in ceramic fibre, with Euroclass fire classification A2-s1, d0 (M0) in panels not removable in contact with the indoor air (top, bottom panel).

Note: the other panels and registers of the indoor circuit always include thermal and acoustic insulation, with Euroclass fire classification A2-s1, d0 (M0).

### Indoor circuit

- Condensate drain pan in stainless steel for corrosion protection.
- Room overpressure management. Assemblies that include a return fan allow the management of airflow differences between supply air and return air of up to 10%, setting up flow setpoints.

Optionally, the fresh air damper and the exhaust damper can be managed independently for greater airflow differences. This option may be necessary to prevent the entry of outside air (BP, BT and BW assemblies).

Note: This option is not available on BA and BB assemblies because this type of control of the dampers penalizes cooling recovery.

- Filter fouling detection with differential pressure switch.

### Outdoor circuit

- Fresh air safety grid (9x9mm).
- Outdoor coil protection grid.
- Antivibration mounts made of rubber.
- Droplet eliminator at the fresh air intake. This one and the thermoenthalpic free-cooling are necessary in cases where a high moisture content in the air is foreseen.

### Heat recovery wheel

- The heat recovery wheel is fitted into a module placed on one side of the unit. This module is supplied disassembled with the unit, for installation on site.

Available with BW assembly, and upon request, with BL assembly.

This rotary recovery unit is used to transfer the sensible and latent heat from the air-conditioned room's return air to the fresh air used for ventilation, before it's discharged outdoors. This option reduces the compressors runtime, ensuring energy saving and benefiting the environment.

The efficiency of energy recovery depend on the wheel selected: wheel material, channel cross section, air filtration and type of speed control.

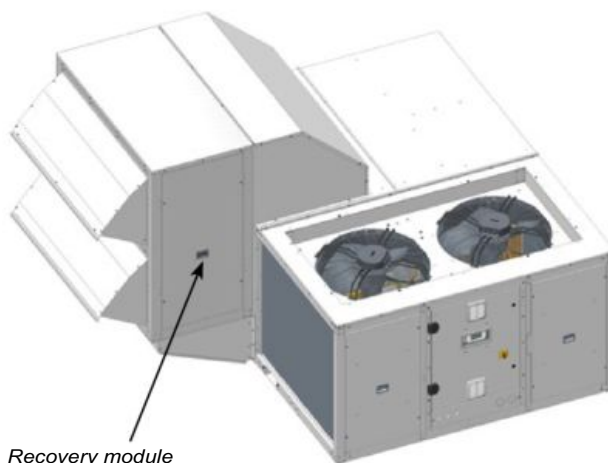

Recovery module

Note: It's recommended to use a CO<sub>2</sub> air quality sensor (optional) in units with rotary heat exchanger.

### Extra heating

- **Heat recovery coil (HRC)**. The coil function is to pre-heat the air that will pass through the main indoor coil. For this, it uses the temperature of an outdoor water installation.

The coil is supplied with a 3-way valve for installation outside the unit but manages by the electronic control. The unit incorporates an anti-freeze thermostat as safety system.

This option is compatible with B1, B2, BF, BT and BB assemblies.

## FACTORY OPTIONS AND ACCESSORIES

- With BF assembly, 100% fresh air, it is possible to incorporate a **preheater module** (electrical heater) coupled to the fresh air intake. This module is supplied in kit for installation on site.

The electrical heater with proportional control will modulate capacity to get the condenser inlet conditions within the operating limits of the cooling circuit in case of very low outdoor temperatures.

Two values of power are available: low (F) and nominal (N).

Note: The electrical connection of the kit is the responsibility of the installer.

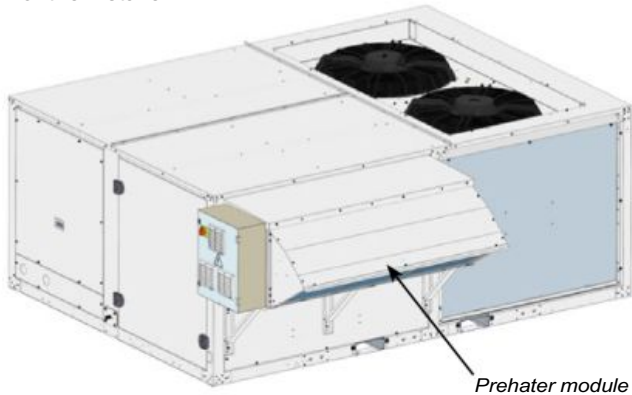

### Special applications

- The mounting **100% fresh air** with no return or extraction air flow (BF assembly) will address special requests where return air flow cannot be used, in order to avoid contamination (kitchens, and some other places with indoor odours or other pollutants).

In order to keep the cooling circuit working inside operation limits, and depending on design conditions, the unit could be selected with lower air flow than minimum used for the same size in the rest of assemblies.

Depending on the heating design conditions, it is also necessary to select an additional electrical heating in the fresh air intake (preheater module).

- Zoning of the air flow** up to 4 different zones.

This option allows the management of the air flow of the unit to condition up to 4 different zones with a minimum air flow of 35% (all in one operating mode: heating or cooling). This function allows to adapt the indoor air flow to the installation requirements.

Note: zoning is only possible with plug-fans.

Regulation gives the control signal to the dampers installed in each zone (dampers and servomotors for those dampers not supplied). The unit modifies the air flow and capacity depending on information coming from sensors in each zone and considering active zones in each moment.

The option includes 4 zone terminals (one for each zone), the additional control board supplied in an independent box to be connected with the 4 terminals, the unit board and also to the servomotors that control dampers in each zone (dampers and servos not supplied).

The temperature information for each zone is coming from temperature sensor integrated inside each zone terminal. It is not needed to install any extra ambient sensor.

Note: In case the unit includes an economizer for enthalpy or thermoentropic free cooling (T+H control) an extra return T+H sensor in the offer is required. If the unit additionally includes CO<sub>2</sub> probe, it must be a return probe and not an ambient probe.

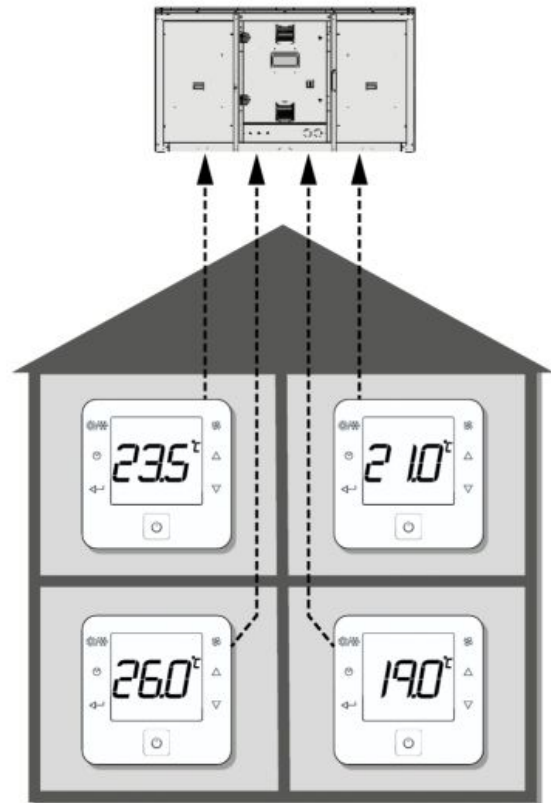

In following picture, electronic PCB and 4 zone terminals are detailed. Connections can be found in the "50FC" control manual.

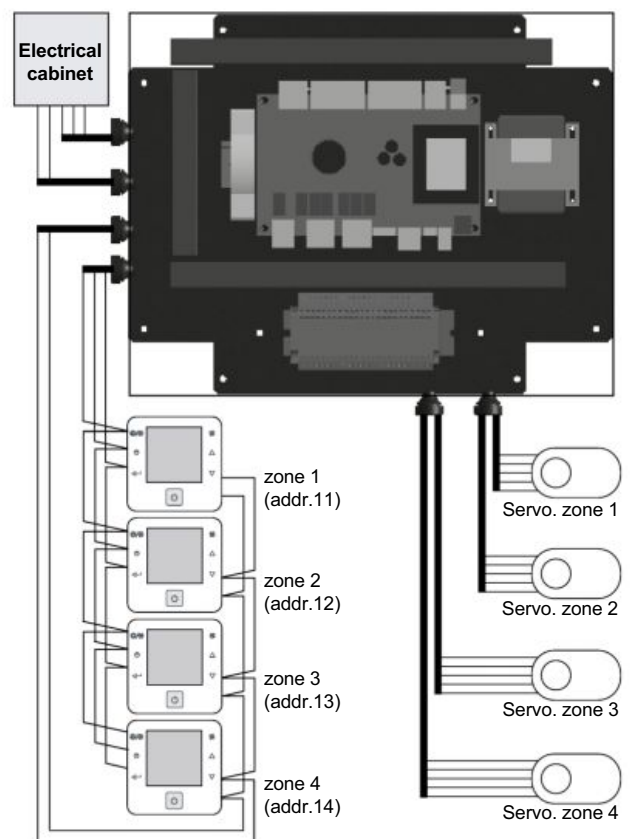

Note: There is a new option with **constant supply pressure** that extends the possibilities for multi-zone management. Available upon request.

## FACTORY OPTIONS AND ACCESSORIES

■ **Low return temperature application.** This option is particularly interesting in certain applications for food conservation and it can be used in large storage facilities. With this option, the unit adapts all its devices to manage low return temperature (15°C) in cooling mode. This is possible due to some changes in the control operation parameters. The "Selection Software" includes the option as mandatory when return temperature is lower than 20°C (with 15°C as the minimum allowed value).

### Sensors

■ **Ambient temperature sensor(s).** There are 3 options:

- One NTC sensor connected to the control board.  
Note: An ambient sensor with RS485 communication is required for installation at more than 30 meters.
- Up to four sensors with RS485 communication.
- Sensor(s) installed on the master unit of the shared network (SHRD).

■ **Ambient temperature + humidity sensor(s).** Up to four sensors with RS485 communication or installed on the shared network (SHRD). This sensor is compulsory in units with enthalpic or thermoenthalpic free-cooling (optional). In this case, the outdoor air humidity sensor is also added.

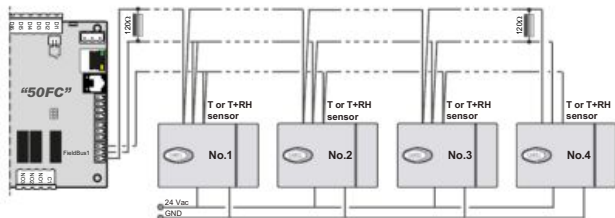

■ **CO<sub>2</sub> sensor for air quality control.** There are 3 options:

- Ambient air quality sensor,
- Return air quality sensor (duct-mounted),
- Sensor(s) installed on the master unit of the shared network (SHRD).

■ **Smoke detection** control unit in accordance with the NF S 61-961 standard, that uses a LED to indicate the installation status, and if the probe detects the presence of smoke in the installation, it stops the operation of the unit and gives the order to open or close the outdoor damper (configured by parameter).

To ensure compliance with the French regulations on Fire safety (ERP), it's possible to select the opening of the fresh air damper and the exhaust air damper to 100% (return air damper closed).

### Economizer management + outdoor humidity

■ The economizer allows to make best use of outdoor air conditions when these are more favourable than the return air conditions. This allows the cooling capacity to be reduced.

The percentage of outdoor air can vary between 0% and 100%.

The economizer management can be:

- Thermal, by comparing the temperatures.
- Enthalpic, by comparing the enthalpies. Recommended in cases where a high moisture content in the air is foreseen.
- Thermoenthalpic, by comparing the enthalpies and correcting for temperature. This is the optimum solution as it takes the variability of the climate into account.

Thermal free-cooling

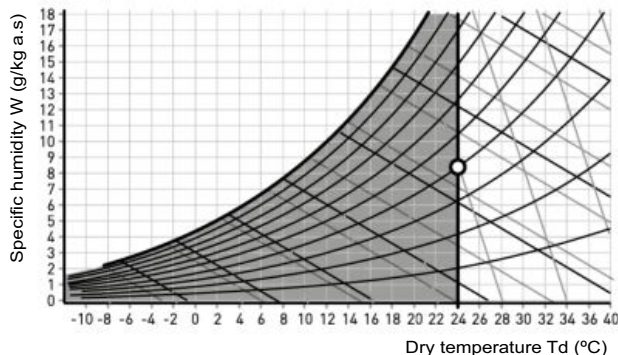

Enthalpic free-cooling

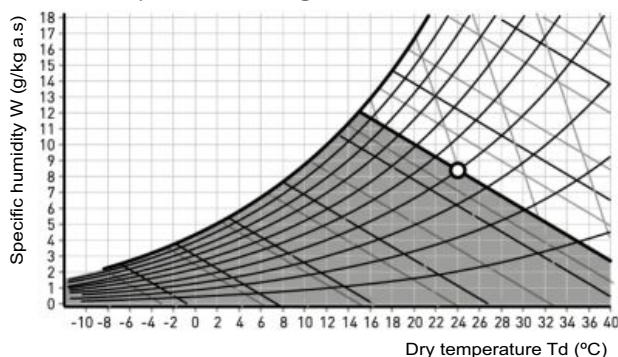

Thermoenthalpic free-cooling

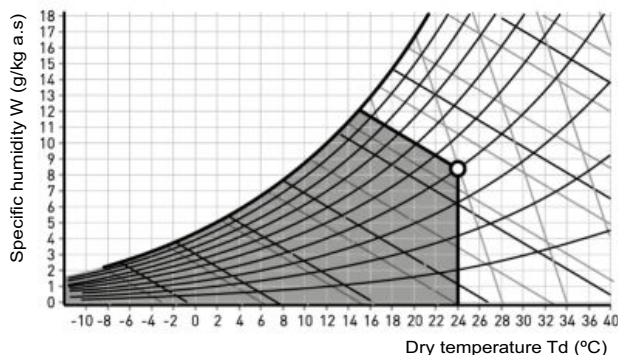

One function that helps improve energy management is **nocturnal free-cooling**. This feature allows the compressors to be disabled in summer with programming, the unit works providing free-cooling at night, when the outdoor conditions are favorable. This allows the cooling demand to decrease significantly early in the day.

■ **Outdoor air humidity sensor** (compulsory in units with optional enthalpic or thermoenthalpic free-cooling).

There are 2 options:

- Sensor supplied with the unit.
- Sensor installed on another unit of the shared network (SHRD).



## FACTORY OPTIONS AND ACCESSORIES

### Terminal + unit communication

■ By default, the electronic control is supplied with a graphic terminal installed in the electrical cabinet of the unit, but these other configurations also are available:

- Graphic terminal installed in the electrical cabinet and User terminal remote up to 100 meters.
- Graphic terminal installed in the electrical cabinet and Graphic terminal remote up to 200 meters (two TCONN bypass cards must be used from 50 to 200 meters).
- User terminal installed in the electrical cabinet, instead of the graphic terminal.
- User terminal installed in the electrical cabinet and Graphic terminal remote up to 200 meters (two TCONN bypass cards must be used from 50 to 200 meters).
- Touch panel installed in the electrical cabinet, instead of the graphic terminal.
- Touch panel installed in the electrical cabinet and Graphic terminal remote up to 200 meters (two TCONN bypass cards must be used from 50 to 200 meters).
- Touch panel installed in the electrical cabinet and User terminal remote up to 100 meters.



Graphic terminal



Touch panel



User terminal

- Control without terminal (for units with shared terminal in a pLAN local network).

Note: Multiple units can share a terminal if they are integrated into a local pLAN network (for up to 15 units). This is not possible in units configured as "Backup", since the two units must be fully autonomous in their operation.

■ By default, the electronic control is configured for a stand-alone unit, but it is also possible to include it in a shared network (SHRD) as Master, Slave or Backup. The maximum number of units that can be integrated into a "Master/Slave" shared network is 15, and in the case of "Backup" it is 2 units.

Important: to use any of the following functionalities it is necessary to configure in the "Selection Program" a unit as Master and all other units as Slaves (including the Backup unit).

The specific functionality will be configured on site (according to the "50FC" regulation manual).

The shared network (SHRD) allows to have the following functionalities depending on the parametrized configuration:

#### - Master/Slave:

It allows to share some of the probes installed in the Master unit: ambient temperature or ambient temperature + humidity, outdoor temperature, outdoor humidity and CO<sub>2</sub> air quality.

#### - Extended Master/Slave:

It includes "Master/Slave" functionalities and the master unit provides ambient temperature setpoints to the other units.

#### - Master/Slave with the same operating mode:

It includes the "Extended Master/Slave" functionalities and the master unit also provides the status (Cooling-Heating - Ventilation) to the other units.

#### - Backup in case of alarm:

One unit is configured as a Backup unit, for activation in case of malfunction of the other unit.

#### - Extended Backup:

It includes the "Backup in case of alarm" functionalities and also, the control manages the automatic switching between the two units weekly, to compensate the operation times of both units.

Note: In the case of installations with Backup units, it is not possible to share the probes, since both units must be fully autonomous in their operation. If both units are connected to the same supply duct network, it is imperative that the installation consists of non-return dampers (installer responsibility).

■ The control board includes two communication ports that allow connection with a centralized technical management system: a BMS port for Modbus RTU protocol and an Ethernet port for Modbus TCP/IP protocol.

A communication card (optional) can also be connected to the board for the following protocols:

- TCP/IP, Modbus TCP/IP, SNMP V1-2-3, FTP, HTTP (E: Ethernet PCoWeb card),
- Ethernet BACnet™ (B: Ethernet BACnet™ card),
- BACnet™ MSTP (C: RS485 BACnet™ card),
- Konnex (K: RS485 Konnex card),
- Modbus RTU (M: RS485 Modbus card).

Note: refer to the electronic control manual for more complete information.

### Local supervision solutions

Different solutions of supervision are available bases on the dimensions of the installation:

#### - pCO Web:

It is a solution for the management and supervision of a single unit through an HTML page included in the Ethernet pCO Web card.

#### - BOSS:

This is the solution for the management and supervision of air-conditioning installations with up to 300 units. Communication is via the Modbus TCP/IP port integrated into the µPC3 control board.

Its main advantages are:

- Integrated WIFI Hotspot for direct access without any extra infrastructure.
- Smartphone compatibility.
- Secure supervisor control from remote through a simple browser.

It offers advanced monitoring and maintenance functions and allows zones and groups to be created to simplify the management of the installation.

## FACTORY OPTIONS AND ACCESSORIES

It also allows energy meters to be integrated to monitor the installation electricity consumption.

BOSS is available in two versions:

- CPU device.
- CPU device, monitor, mouse and keyboard.

### - BOSS mini:

This is the solution for the management and supervision of air-conditioning installations with up to 10 units with 50 variables per unit or 50 units with 10 variables maximum per unit, but with the same features as BOSS.

BOSS mini is available in two versions:

- CPU device.
- CPU device, monitor, mouse and keyboard.



These systems are used to manage the installation remotely. All the information on the system can be accessed via a simple Internet connection. The online interface, the same one used by the local user, enables monitoring and complete configuration of the installation: from the office or anywhere else the user happens to be.

### Remote supervision solution

**ABOUND HVAC Performance** is a remote supervision solution dedicated to monitoring and controlling several CARRIER machines in real time.

ABOUND HVAC Performance will send data in real time to the supervision website. The machine operating data can be accessed from any PC, smartphone or tablet. Any event can be configured to trigger a mail alert.

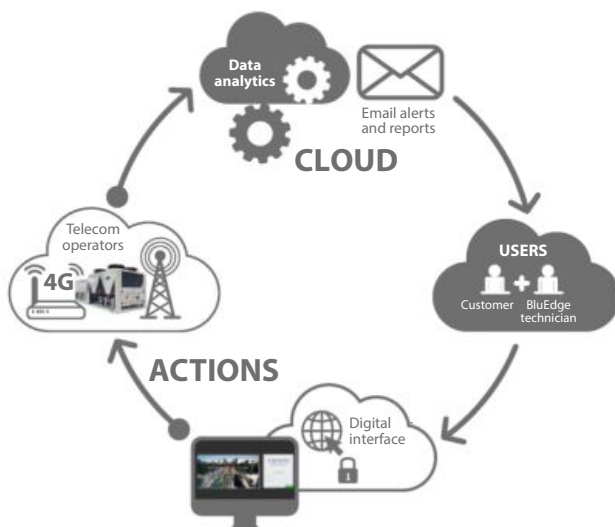

### Miscellaneous item 1

- Management of an humidifier with on-off or proportional control.
- Electrical energy meter for monitoring of the power consumption of the installation.
- Energy meter and calculation of the cooling and heating capacities. In addition to the energy meter, the unit incorporates mixing and supply enthalpic sensors with RS485 communication that enable cooling and heating capacities to be calculated.

### Miscellaneous item 2

- Compressor soft starter.
- Varnish protection for the components on the electrical cabinet: control board, cards and terminals.
- High performance phase monitoring relay, which ensures phase-sequence monitoring and protection against loss of phase, under and overvoltage as well as phase imbalance. Highly recommended for installations with power system voltage instability, high level of electromagnetic disturbances EMC, etc.

### Return fan

- Centrifugal return fan, coupled by pulleys and belts. Electric motor with tensioner, class F, IP55 and internal thermal protection. Turbine with an impeller of front-curved blades. Greased spherical bearings, with no maintenance required. Available in BB and BT assemblies.

There are 9 fan options depending on:

- Air flow: low, nominal and high.
- Available pressure: low, nominal and high.

- Return plug-fan with nominal available pressure, in Aluminium.

### Pre-assembly roof curbs

- The units can rest on pre-assembly roof curbs with adjustable height, built in galvanised steel panelling with polyester paint and thermal insulation.

The levelling system uses angle pieces that allow adjustments in the X and Y axes.

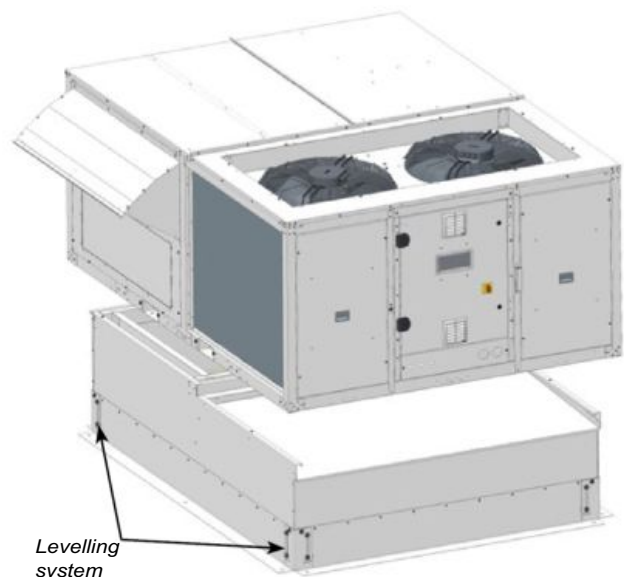

- Adaptation roof curbs ready for direct replacement on site of units from different manufacturers (**upon request**).

## ADDITIONAL FACTORY OPTIONS UPON REQUEST

This chapter contains additional options available upon request, in addition to those already indicated in the table on the previous chapter:

Description	Installation in factory	Installation on site	
Options of electronic control	Activation of the remote COOLING / HEATING operating mode	✓	
	General alarm signalling by relay	✓	
	Mechanical disconnection of stages	✓	
	Ventilation mode with 100% fresh air by digital input	✓	
	Control of supply and return dampers		✓
	Ventilation with differential air pressure sensor		✓
Constant supply pressure		✓	
Adjustable pre-assembly roof curbs with higher height		✓	

### General alarm signalling

"50FC" control allows the management of a relay for remote alarm signalling.

The output for general alarm signal is not compatible with the following options: hot water coil, heat recovery coil, rotary heat exchanger and on/off signal for external humidifier.

In this case, upon request, it would be possible to have a general alarm output in an input/output expansion module.

### Mechanical disconnection of stages

This option allows the mechanical disconnection of stages of compressor and/or electrical heaters using digital inputs. This is especially useful in the following cases:

- To reduce electricity consumption in certain time slots.
- When electricity consumption is limited.

### Ventilation mode with 100% fresh air by digital input

"50FC" control allows to manage a ventilation mode with 100% fresh air through the graphic terminal or by BMS supervision, but on certain occasions it may be interesting to activate this mode through a digital input. This option is especially useful when rapid air renewal is needed, for example in cinema rooms.

### Control of supply and return dampers

This function allows the management of external drive and return dampers located in the ducts, so that the closure of the ducts can be controlled after the unit is stopped. This option can also be useful in installations with Backup units.

### Ventilation with differential air pressure sensor

In installations with this differential pressure sensor, the percentage of air renewal is adjusted according to the pressure in the room. This option allows dynamic control of the damper opening by measuring the pressure differential between inside and outside.

### Constant supply pressure

The 50FF/FC range provides the greatest choice in terms of multi-zone management. This new option of "Constant supply pressure" is added to the option "Air flow zoning up to 4 zones".

This function allows to control the air flow to maintain constant pressure in the supply duct, with the setpoint value set by parameter.

The following table provides the comparison of the two solutions to facilitate the correct selection according to the customer needs:

Characteristics	Zoning up to 4 zones	Constant supply pressure
Number of zones	Up to 4	Unlimited
Type of fan	Plug-fan	Plug-fan
Components included	4 zone terminals and a control box	Differential pressure sensor (range 0 - 1000 Pa)
Dampers and servos per zone	Not supplied	Not supplied
Control signal for dampers / servos	Supplied	Not supplied (external control required)
Control of the damper for each zone	Yes, control carried out by the electronic control	No (at customer level)
Terminal in each zone	Yes	No or just one for the main zone (see "Configurations")
Minimum air flow	35%	35% or 10% in ventilation mode (operating only the fans). There is an associated alarm in case of lower airflow. It is necessary to set the minimum damper opening per zone or provide remote stop control in case all dampers are closed
Capacity control	Based on the ambient temperature conditions of each zone terminal (by default) or the return temperature (optional)	<ul style="list-style-type: none"> <li>• Based on the return conditions (by default)</li> <li>• Based on the environment conditions (configurable), in case of a main zone (see "Configurations")</li> </ul>

Configurations	
Capacity control based on the return conditions (by default)	Capacity control based on the environment conditions (configurable)
Several zones	Several zones (one main zone)
Same comfort priority by zone	One main zone. Comfort of all zones depends on the demand of the main zone

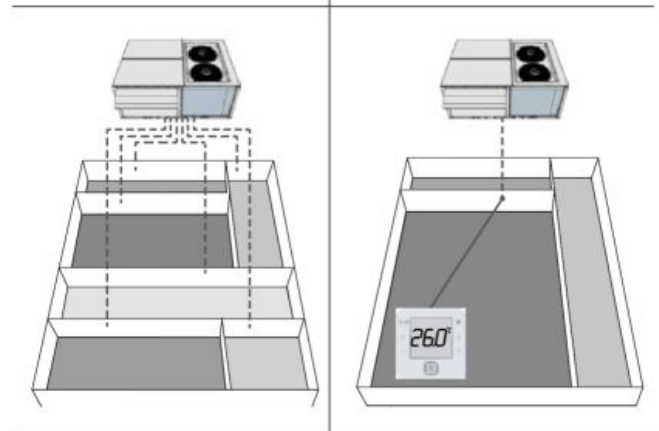

Note: For variable management of fresh air it is necessary to select the optional return air quality probe (CO<sub>2</sub>) (instead of the ambient probe).

There is only one case in which the ambient air quality probe can be used: with constant supply pressure and capacity based on the environmental conditions of the main zone.



## WEIGHT OVERVIEW

### Weight overview of the various assemblies (kg)

50FF/FC		020	028	037	040	045	047	052	058	062	070	074	086	093	
50FF series	B1 assembly	594	617	699	698	704	701	914	929	936	1035	1059	1057	1078	
	B2 and BF assemblies	609	632	718	718	718	720	946	967	969	1070	1094	1112	1113	
	B3 assembly	682	705	796	796	796	798	1047	1062	1070	1197	1221	1230	1231	
	BX assembly	713	736	815	815	815	817	1090	1111	1112	1248	1272	1290	1291	
	BP assembly	723	746	831	831	828	833	1120	1141	1142	1276	1300	1309	1310	
	BA assembly	781	804	900	900	897	902	1211	1232	1233	1379	1403	1412	1413	
	BT assembly	774	797	882	882	882	884	1213	1228	1236	1371	1395	1413	1414	
	BB assembly	832	855	951	951	951	953	1304	1319	1327	1474	1498	1516	1517	
	BW assembly	Machine	722	745	834	834	834	837	1122	1143	1145	1206	1230	1248	1249
		Recovery module	254	254	254	254	254	254	348	348	348	454	454	454	454
Total weight		976	999	1088	1088	1088	1091	1470	1491	1493	1660	1684	1702	1703	
50FC series	B1 assembly	594	617	699	698	704	701	986	986	1004	1146	1146	1135	1160	
	B2 and BF assemblies	609	632	718	718	718	720	1018	1024	1037	1181	1181	1190	1195	
	B3 assembly	682	705	796	796	796	798	1119	1119	1138	1308	1308	1308	1313	
	BX assembly	713	736	815	815	815	817	1162	1168	1180	1359	1359	1368	1373	
	BP assembly	723	746	831	831	828	833	1192	1198	1210	1387	1387	1387	1392	
	BA assembly	781	804	900	900	897	902	1283	1289	1301	1490	1490	1490	1495	
	BT assembly	774	797	882	882	882	884	1285	1285	1304	1482	1482	1491	1496	
	BB assembly	832	855	951	951	951	953	1376	1376	1395	1585	1585	1594	1599	
	BW assembly	Machine	722	745	834	834	834	837	1194	1200	1213	1317	1317	1326	1331
		Recovery module	254	254	254	254	254	254	348	348	348	454	454	454	454
Total weight		976	999	1088	1088	1088	1091	1542	1548	1561	1771	1771	1780	1785	

### Weight supplement from the main options (kg)

50FF/FC		020	028	037	040	045	047	052	058	062	070	074	086	093	
Pre-assembly roof curb (without gas burner)		145	145	145	145	145	145	205	205	205	237	237	237	237	
Pre-assembly roof curb (with gas burner)	BAF (Low)	265	265	265	265	265	265	--	--	--	--	--	--	--	
	BAM (Nominal)	274	274	274	274	274	274	385	385	385	463	463	463	463	
	BAS (High)	284	284	284	284	284	284	411	411	411	483	483	483	483	
Electrical heaters	RAF (Low)	20	20	20	20	20	20	17	17	17	17	17	17	17	
	RAM (Nominal)	17	17	17	17	17	17	21	21	21	21	21	21	21	
	RAS (High)	--	--	21	21	21	21	25	25	25	25	25	25	25	
Hot water coil (HWC)	Standard	Empty	33	33	37	37	37	37	51	51	51	58	58	58	58
		Service	40	40	46	46	46	46	67	67	67	78	78	78	78
	Very low outdoor T	Empty	41	41	45	45	45	45	71	71	71	78	78	78	78
		Service	49	49	55	55	55	55	89	89	89	100	100	100	100
Heat recovery coil (HRC)	Empty	22	22	21	21	21	21	30	30	30	36	36	36	36	
	Service	31	31	31	31	31	31	44	44	44	53	53	53	53	
Preheater in fresh air	Low power	93	93	93	93	93	93	121	121	121	144	144	144	144	
	Nominal power	105	105	105	105	105	105	138	138	138	165	165	165	165	
Supply fan	Low pressure (F)	-7	-7	--	--	--	--	-21	-21	-21	--	--	-9	-9	
	Nominal pressure, aluminium (M)	4	4	8	8	8	8	9	9	9	9	9	0	0	
Droplet eliminator	High pressure (S)	4	4	28	28	28	28	38	38	38	29	29	29	29	
	Indoor coil	24	24	25	25	25	25	34	34	34	43	43	43	43	
Filters	Fresh air intake	8	8	8	8	8	8	11	11	11	14	14	14	14	
	G4 l.p.d.	2	2	2	2	2	2	2	2	2	3	3	3	3	
	G4 + M6	6	6	6	6	6	6	9	9	9	11	11	11	11	
	G4 + F7 // G4 + F9	6	6	6	6	6	6	9	9	9	12	12	12	12	
	G4 l.p.d. + F7 // G4 l.p.d. + F9	7	7	7	7	7	7	11	11	11	14	14	14	14	
	M6 + F7 // M6 + F9	8	8	8	8	8	8	13	13	13	17	17	17	17	
Centrifugal return fan (BT and BB assemblies)	F7 + F9 // F9 + F9	9	9	9	9	9	9	13	13	13	17	17	17	17	
	A: Low flow + nominal pressure	-8	-7	7	10	10	10	-21	-21	-21	20	20	20	20	
	B: Low flow + high pressure	-1	3	31	31	31	31	0	10	10	30	30	30	30	
	C: Nominal flow + nominal pressure	-7	7	13	17	17	17	-1	-1	-1	47	47	47	47	
	D: Nominal flow + high pressure	3	9	38	38	38	38	26	26	26	145	145	145	145	
	E: High flow + nominal pressure	0	13	17	36	36	36	20	27	27	60	60	60	60	
	F: High flow + high pressure	9	15	48	63	48	48	44	44	44	145	145	185	185	
	G: Low flow + low pressure	-10	-2	1	7	7	7	-2	-2	-2	10	10	-2	-2	
	H: Nominal flow + low pressure	-2	7	8	34	35	35	3	3	3	14	14	14	14	
I: High flow + low pressure	1	7	34	40	40	40	21	21	21	56	56	56	56		
Return plug-fan	BP, BA assemblies	3	3	3	3	3	3	6	6	6	6	6	6	6	
	BT, BB assemblies	3	3	3	3	3	3	--	--	--	6	6	6	6	
	BW assembly	3	3	0	0	0	0	--	--	--	0	0	0	0	

## RECOMMENDED SERVICE CLEARANCE

### 50FF/FC 020-028-037-040-045-047: B1, B2 and BF assemblies

50FF/FC	Overall dimension (mm)			Service clearance (mm)			
	Length	Width	Height (*)	A	B	C	D
020 to 047	2.225	1.750	1.230	1.200	1.000	1.000	1.600

(\*) With 2-speed outdoor fan (optional) add +275 mm.

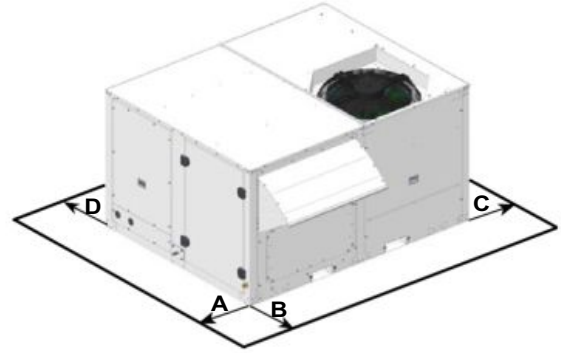

### 50FF/FC 020-028-037-040-045-047: B3, BX, BP and BA assemblies

50FF/FC	Overall dimension (mm)			Service clearance (mm)			
	Length	Width	Height	A	B	C	D
020 to 047	2.230	1.755	1.905	1.200	1.000	1.000	1.600

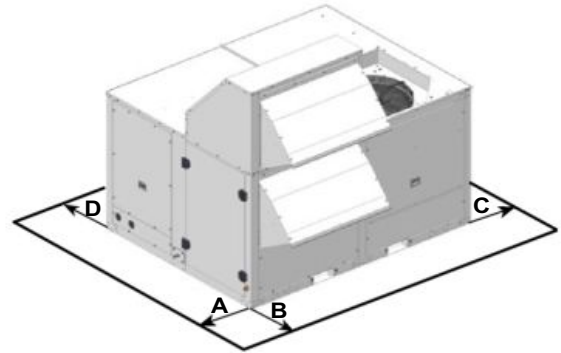

### 50FF/FC 020-028-037-040-045-047: BT and BB assemblies

50FF/FC	Overall dimension (mm)			Service clearance (mm)			
	Length	Width	Height	A	B	C	D
020 to 047	2.230	1.760	1.975	1.200	1.000	1.000	1.600

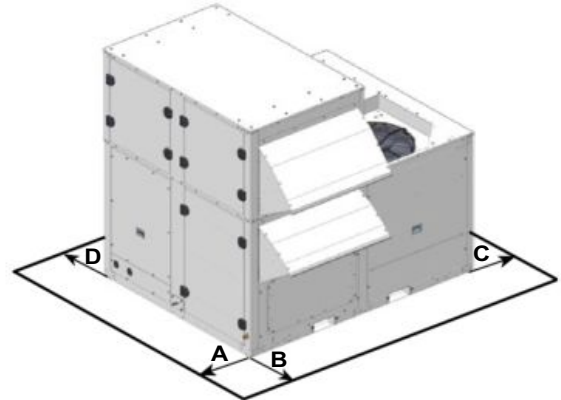

### 50FF/FC 020-028-037-040-045-047: BW assembly

50FF/FC	Overall dimension (mm)			Service clearance (mm)			
	Length	Width	Height	A	B	C	D
020 to 047	2.230	2.565	1.905	1.200	1.000	1.000	1.600

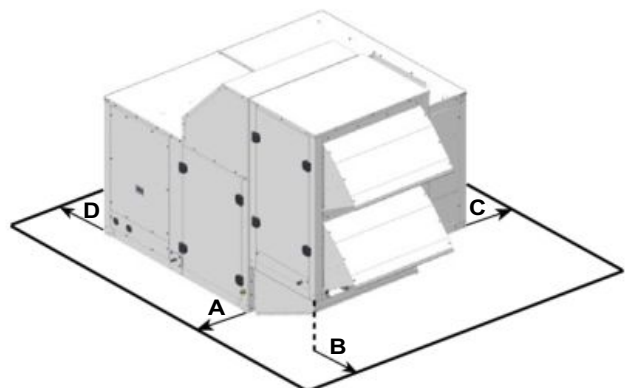

**NOTE:**

- Unit not designed to have overhead obstruction.

## RECOMMENDED SERVICE CLEARANCE

### 50FF/FC 052-058-062-070-074-086-093: B1, B2 and BF assemblies

50FF/FC	Overall dimension (mm)			Service clearance (mm)			
	Length	Width	Height (*)	A	B	C	D
052 to 062	3.000	2.200	1.230	1.600	1.000	1.000	1.000
070 to 093	3.655	2.200	1.230	2.000	1.000	1.000	1.000

(\*) With 2-speed outdoor fan (optional) add +275 mm.

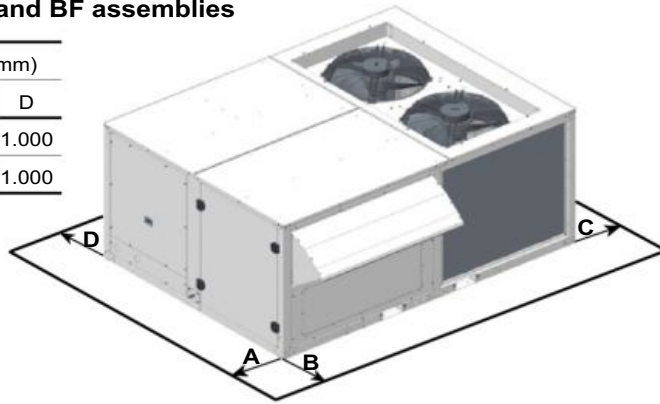

### 50FF/FC 052-058-062-070-074-086-093: B3, BX, BP and BA assemblies

50FF/FC	Overall dimension (mm)			Service clearance (mm)			
	Length	Width	Height	A	B	C	D
052 to 062	3.000	2.205	1.905	1.600	1.000	1.000	1.000
070 to 093	3.655	2.205	1.905	2.000	1.000	1.000	1.000

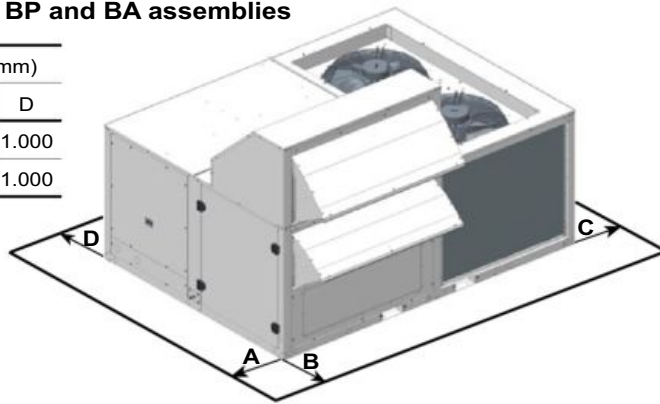

### 50FF/FC 052-058-062-070-074-086-093: BT and BB assemblies

50FF/FC	Overall dimension (mm)			Service clearance (mm)			
	Length	Width	Height	A	B	C	D
052 to 062	3.000	2.210	1.995	1.600	1.000	1.000	1.000
070 to 093	3.655	2.210	1.995	2.000	1.000	1.000	1.000

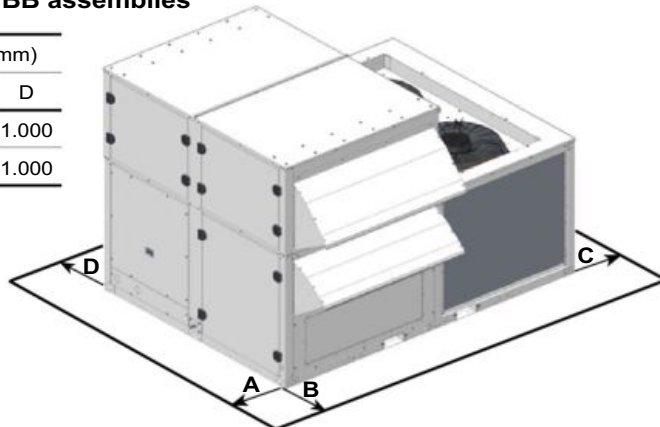

### 50FF/FC 052-058-062-070-074-086-093: BW assembly

50FF/FC	Overall dimension (mm)			Service clearance (mm)			
	Length	Width	Height	A	B	C	D
052 to 062	3.000	3.015	1.905	1.600	1.000	1.000	1.000
070 to 093	3.655	3.015	1.905	2.000	1.000	1.000	1000

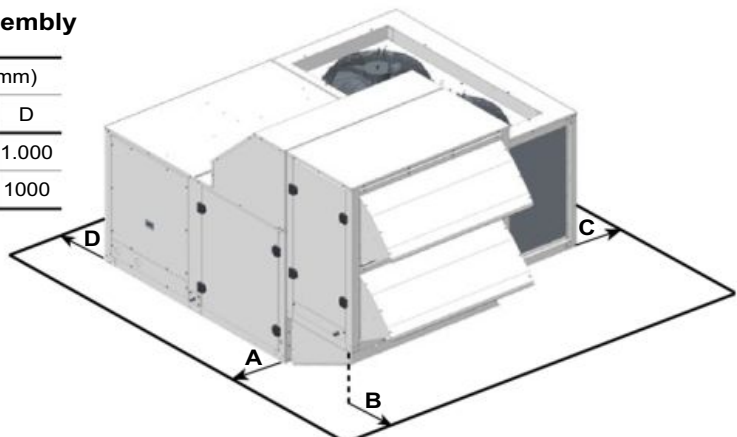

**NOTE:**

- Unit not designed to have overhead obstruction.



## PACKAGED ROOFTOP UNITS WITH R-454B



- Low environmental impact
- High full and part load efficiency
- Compact and simple to install
- Low refrigerant charge
- Low sound level
- Energy recovery
- Variable speed EC fans

## 50FF/FC 100 - 280 R-454B\*

\* Also available in R-410A

Nominal cooling capacity 96.6 - 272.9 kW  
 Nominal heating capacity 97.1 - 299.2 kW

The **50FF/FC R-454B** consists of autonomous and packaged air-to-air units of horizontal construction, rooftop-type design.

- **50FF series:** for **cooling-only** operation.
- **50FC series:** for **reversible heat pump** operation.

The range of available capacities in the series allows for the air conditioning of medium and large surface areas which are common in shopping malls, food retail, logistics and many other commercial and industrial applications.

50FF/FC units are designed for optimized part-load management in achieving the highest levels of seasonal efficiency, exceeding the limits set by regulation.

With its mono-block lightweight construction, the units feature a self-supporting frame, designed to ease the installation and maintenance works.

The units integrate the latest technological innovations:

- Multi-scroll compressors in tandem.
- Electronic expansion valves.
- Variable speed EC fans.
- Auto-adaptative microprocessor control.

For maximum adaptability, a number of options is available to meet any operating requirement:

- Exhaust air energy recovery.
- Economizer.
- Indoor air quality management.
- Available static pressure up to 80 mm.w.c.
- Zoning with variation of airflow.
- Installation roof curbs.
- Auxiliary heating modules.
- Extended operation limits.



CARRIER participates in the ECP programme for RT  
 Check ongoing validity of certificate:  
[www.eurovent-certification.com](http://www.eurovent-certification.com)



## CUSTOMER BENEFITS

### Outstanding performance

50FF/FC 100-280 units are designed for optimized part-load management in achieving the highest levels of seasonal efficiency, exceeding the limits set by regulation.



The unit integrates the latest technological innovations:

- Multi-scroll compressors in tandem optimized for R-410A and R-454B refrigerant (bivalent compressors).
- Electronic expansion valves.
- Outdoor EC fans with variable speed.
- Supply EC plug-fans with direct drive and variable speed.
- Auto-adaptative microprocessor control.

### Intelligence and connectivity

The advanced "50FC" intelligent control system displays operating parameters in real-time, making it intuitive and particularly user-friendly. The 50FF/FC range is also characterized by a brand new smart energy monitoring function that provides users with smart data such as electrical energy consumption in real-time, supplied cooling and heating energy as well as instantaneous and average seasonal energy efficiency values.

It also guarantees easy installation and integration into the building management system.

- Plug & play solution fully programmed and set up from the factory.
- Wide supervision offer from 1 to 300 units.
- Communication with all building management system protocols through Modbus, BACnet, Konnex, TCP/IP, SNMP V1-2-3, FTP and HTTP.

### Adaptability

The range offers a wide range of options and a large set of configurations to customize the unit according to your needs:

- Exhaust air energy recovery.
- Economizer.
- Indoor air quality management.
- Available static pressure up to 800 Pa.
- Adjustable or adaptation roof curbs.
- Auxiliary heating systems.
- Extended operation limits in heating mode for adaptation to extreme temperatures.
- 4 zone management with airflow control option.
- Heat recovery water coil.
- Low return temperature option for storage applications.
- Double panel option with 50 mm insulation.

### Indoor air quality

The 50FF/FC range offers a wide range of technological features dedicated to improve and maintain the highest level of indoor air quality:

- Ventilation of spaces with outdoor air. It reduces indoor pollutants to maintain indoor air quality.
- Air filtration. It is an efficient way to reduce particles that can harm our health. Filter fouling detector determines when the filter needs to be replaced.
- CO<sub>2</sub> sensors that allow ventilation based on the comparison of CO<sub>2</sub> levels between indoor and outdoor sources.
- Air flow control. It ensures proper comfort in spaces: temperature, humidity, air flow and overpressure.

Discover more about Carrier's approach to Healthy Buildings on: <https://www.corporate.carrier.com/healthybuildings/>

### Energy savings

This range has been designed to reduce energy consumption with advanced features:

- Variable ventilation with electronic plug-fans.
  - In tertiary sector installation, a high percentage of the annual air conditioning energy consumption comes from the use of fans for transporting air. Using fans which are more efficient has a direct impact on reducing consumption.
- Low pressure drop filters.
- Free-cooling allows to make best use of outdoor air conditions when these are more favourable than the return air conditions. This allows the cooling capacity to be reduced. Up to 30% energy savings due to the cooling capacity reduction.
- Energy recovery systems:
  - **Active recovery:**
    - High performances in mild weather
    - Additional cooling circuit, independently controlled, for energy recovery from the exhaust air.

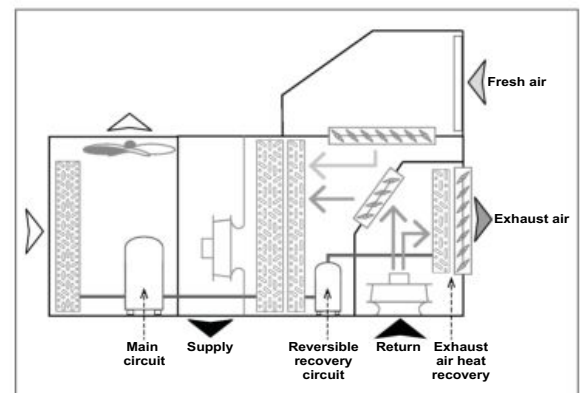

#### - Passive recovery:

- Recommended with low outdoor temperatures in winter, and high fresh air ratios.
- A rotary heat exchanger, coupled to the machine, transfers heat and humidity from the air-conditioned room's return air to the fresh air used for ventilation, before its discharged outdoors.

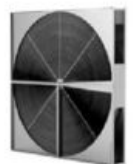

All these energy-efficient solutions lead to substantial cost savings.

## CUSTOMER BENEFITS

### Extensive scope of applications

Some options in the 50FF/FC units are aimed at applications with a wider temperature range:

- Air zoning to control up to 4 zones or in case of large surfaces with high thermal dispersion.
- Heat recovery coil using energy rejected by food refrigeration system or industrial process.
- **Airflow extension** to provide the proper solution when larger airflow in comparison with capacity is required.
- Low return temperature 15°C in cooling mode operation which allows to answer the request of certain application as food conservation in large store facilities.

### Low sound levels

50FF/FC units provide a low-noise level during operation thanks to design optimization and the latest technology to meet the most exigent requirements.

- Up to 70% of the operation time below half-load.
- Sound level reduction in partial load operation.
- Night operation mode available with free-cooling and disabling compressors. This also helps to reduce the sound level during night periods.

### Easy and fast installation

With its mono-block lightweight construction, the 50FF/FC units feature a self-supporting frame, designed to ease the installation and maintenance process. The units are connected directly to an air distribution ductwork without additional elements or equipment, pipes, cables, etc. taking no floor space at all. This design reduces the cost of installation, facilitates a quick connection and ensures reliable operation.

- Vertical supply/return airflow configurations are ideal for new construction or retrofit projects.
- Horizontal airflow configurations are ideal for replacement or applications such as through-the-wall where sound must be attenuated before the duct penetrates the roof.



Models 100 to 170



Models 180 to 280

### Superior reliability

The 50FF/FC has been designed to ensure robustness throughout the lifecycle of the units. The high-reliability of the units is the result of **high-quality material and components** combined with the **highest quality standards** in terms of manufacturing and laboratory testing.



### EcoPassport®

The PEP ecopassport® programme provides an international reference framework for procedures enabling manufacturers to communicate the environmental specifications of their products in the form of an eco-declaration, known as the Product Environmental Profile (PEP).

The PEP ecopassport® programme guarantees that PEPs are created, checked and communicated correctly according to the requirements of standard ISO 14025 and standard IEC/PAS 62545.

The Life Cycle Analysis (LCA) PEP is the environmental identity card for an item of equipment which details the environmental impacts of the product during its life cycle according to **eight mandatory indicators**:

1. Global Warming Potential
2. Impact on the ozone layer
3. Acidification of soil and water
4. Eutrophication of water
5. Photochemical ozone creation
6. Abiotic resource depletion
7. Fresh water consumption
8. Total use of primary energy during the life cycle

**CARRIER** is the first HVAC manufacturer to provide PEPs for rooftops, not only the 8 mandatory indicators, but all **27 indicators**.

Products with certified environmental profiles are used to support methods to assess building sustainability such as BREEAM or LEED. They give additional recognition for materials with robust environmental product declaration types using manufacturer data.

The PEP of **50FF/FC R-454B** can be downloaded from the PEP ecopassport® website: <http://www.pep-ecopassport.org>



# KEY FOR CONFIGURATION

A	B	C	D	E	F	G	H	I	J	K	L	M	N	O	P	Q	R	S	T	U	V	W	X	Y
50FC	0100	A	4	B	B1	LL	000	S	N	A	H	S	000	0000	0000	0	0	AA00	00	A00	000	AA00	0000	0000

**A: Unit type**

50FF: air/air cooling-only  
50FC: air/air heat pump

**B: Unit model**

2 circuits: 0100 / 0110 / 0120 / 0130 / 0145 / 0160 / 0170 / 0180 / 0200 / 0220 / 0250 / 0280

**C: Version of the series**

A: Current version

**D: Electrical power**

4: 400V / 3ph + N / 50Hz  
5: 400V / 3ph / 50Hz

**E: Type of refrigerant**

B: R-454B

**F: Airflow + Assembly**

B1: Standard  
B2: Economizer, 2 dampers  
BP: Plug-fan in return section  
BA: Cooling recovery circuit with plug-fan in return section  
BT: Return top box with plug-fan or centrifugal fan  
BB: Cooling recovery circuit with plug-fan or centrifugal fan in return top box  
BW: Heat recovery wheel module

**G: Coil coating : Indoor - Outdoor**

LL: Aluminium - Aluminium  
LP: Aluminium - Polyurethane  
LN: Polyurethane - Inera®  
PP: Polyurethane - Polyurethane  
PN: Polyurethane - Inera®  
NN: Inera® - Inera®

**H: Heating**

000: Without auxiliary heating  
BAx: Gas burner, 2 power outputs:  
x = M (Nominal) / S (High)  
RAx: Electrical heaters, 3 power outputs:  
x = F (Low) / M (Nominal) / S (High)  
HAx: Hot water coil:  
x = S (Standard)

**I: Protection for low outdoor temperature**

S: Without protection  
A: Freeze protection OAT lower than -10°C  
B: Freeze protection OAT lower than -14°C  
C: Freeze protection OAT lower than -10°C + spring shut-off dampers  
D: Freeze protection OAT lower than -14°C + spring shut-off dampers

**J: Supply fan**

F: Low available pressure (aluminium)  
N: Nominal available pressure  
M: Nominal available pressure (aluminium)  
S: High available pressure (aluminium)

**K: Air filtration + droplet eliminator**

A: G4  
B: G4+ droplet eliminator  
C: G4 low pressure drop  
D: G4 low pressure drop + droplet eliminator  
G: G4 + F7  
H: G4 + F7 + droplet eliminator  
K: G4 low pressure drop + F7  
L: G4 low pressure drop + F7 + droplet eliminator  
O: M6 + F7

P: M6 + F7 + droplet eliminator  
S: F7 + F9  
T: F7 + F9 + droplet eliminator

**L: Outdoor fan**

L: AC (2-speed)  
H: EC (electronic)

**M: Insulation**

S: Standard insulation  
M: Insulation M0 with double wall (50mm)

**N: Indoor circuit**

000 - Without optional accessories  
A: Condensate drain pan in stainless steel  
A: Room overpressure management  
A: Filter fouling detector

**O: Outdoor circuit**

0000 - Without optional accessories  
A: Fresh air safety grid  
A: Outdoor coil protection grid  
A: Antivibration mounts  
A: Droplet eliminator at the fresh air intake

**P: Heat recovery wheel**

0000 - Without optional accessories  
4: Wheel diameter: 1500 mm  
5: Wheel diameter: 1800 mm  
6: Wheel diameter: 2000 mm  
7: Wheel diameter: 2200 mm  
A: Wheel speed with on/off control  
B: Wheel speed with variable control  
A: Channel cross section of 2,0 mm  
B: Channel cross section of 2,5 mm  
A: Material : Aluminium  
C: Material : Hybrid wheel  
D: Material : Aluminium with silicagel

**Q: Extra heating**

0: Without extra heating  
B: Heat recovery coil

**R: Special applications**

0: Without special applications  
C: Air zoning  
D: Low return temperature application  
I: Low T application + Air zoning

**S: Sensors**

0000 - Without optional accessories  
A: Smoke detection control unit  
A: CO<sub>2</sub> sensor environment installation  
B: CO<sub>2</sub> sensor ducted installation  
C: CO<sub>2</sub> sensor on the SHRD network  
A: 1 sensor RS485  
B: 2 sensors RS485  
C: 3 sensors RS485  
D: 4 sensors RS485  
E: 1 sensor NTC  
A: Ambient temperature sensor  
B: Ambient temp. + humidity sensor  
C: Ambient sensor on the SHRD network

**T: Economizer management + Outdoor hum.**

00 - Without economizer + without sensor  
A: Outdoor humidity sensor on the unit  
B: Outdoor hum. sensor on SHRD network  
A: Thermal management  
B: Thermoeconomic management  
C: Enthalpic management

**U: Terminal + Unit communication**

000 - Without terminal + stand-alone unit + without communication card  
A: Card RS485 Modbus/Carel  
B: Card Ethernet PCoWeb  
C: Card RS485 LonWorks®  
D: Card Ethernet BACnet™  
E: Card RS485 BACnet™  
F: Card RS485 Konnex  
0: Stand-alone unit  
A: Master unit  
B: Slave unit  
A: Graphic terminal in electrical cabinet  
B: User terminal in electrical cabinet  
C: Graphic terminal in the cabinet + User terminal remote up to 100 m  
D: User terminal in the cabinet + Graphic terminal remote up to 200 m  
E: Graphic terminal in the cabinet + Graphic terminal remote up to 200 m  
F: Touch panel in electrical cabinet  
G: Touch panel in the cabinet + Graphic terminal remote up to 200 m  
H: Touch panel in the cabinet + User terminal remote up to 100 m

**V: Miscellaneous item 1**

000 - Without optional accessories  
A: On-off control of an humidifier  
B: Proportional control of an humidifier  
A: Electrical energy meter  
B: Cooling capacity & elec. energy meter  
Unused

**W: Miscellaneous item 2**

AA00 - Without optional accessories  
Unused  
A: Varnish protection  
Unused  
Unused

**X: Return fan**

0000 - Without return fan  
A: Centrifugal, low airflow  
C: Centrifugal, nominal airflow  
E: Centrifugal, high airflow  
N: Plug-fan, nominal pressure  
M: Plug-fan, nominal pressure (aluminium)  
S: Plug-fan, high pressure (aluminium)  
Unused

**Y: Indoor airflow direction**

0000 - Lower direction  
0: Lower supply and lower return (B1, B2, BP, BA and BW assemblies)  
1: Lateral supply and lower return (B1, B2, BP, BA and BW assemblies)  
2: Lower supply and lateral return (B1, B2, BT and BB assemblies)  
3: Lateral supply and lateral return (B1, B2, BT and BB assemblies)  
4: Upper supply and lower return (B1 and B2 assemblies)  
5: Lateral supply and upper return (B1 and B2 assemblies)  
6: Upper supply and lateral return (B1 and B2 assemblies)  
7: Lower supply and upper return (B1 and B2 assemblies)  
8: Upper supply and upper return (B1 and B2 assemblies)  
Unused  
0: Without pre-assembly roof curb  
1: With pre-assembly roof curb  
Unused



## R-454B: THE BEST SOLUTION FOR ROOFTOPS

CARRIER offers the best refrigerant choice according to applications, conditions and technologies.



**CO<sub>2</sub> FOOTPRINT**  
REDUCED BY UP TO **80%**

R-454B is currently the ideal refrigeration solution for rooftops. By using R-454B refrigerants, Carrier has reduced the carbon footprint of its version with R-410A by an astonishing 80%.

R-454B is also the right choice economically, reducing the locally imposed tax burden on HFCs based on the CO<sub>2</sub> impact.

The impact of an air conditioning system on global warming of the planet is in large part caused by CO<sub>2</sub> emissions released into the atmosphere when the electricity required to power the unit is produced (**indirect effect**) and in small part by CO<sub>2</sub> emissions linked to uncontrolled emissions of refrigerant with global warming potential into the atmosphere (**direct effect**).

### Direct effect. Lower environmental impact ⇒ -80% compared to R-410A

- R-454B has zero Ozone Depletion Potential (ODP).
- The Global Warming Potential (GWP) of R-454B is 466, i.e. approximately one third of that of R-410A (GWP 2088), and 30% lower than R-32 (GWP 675).
- The 50FF/FC R-454B cooling charge is reduced by 10% compared to the version using R-410A\*
- The carbon footprint of the 50FF/FC R-454B is therefore 420 (466 x 0.9), i.e. 88% lower than the version using R-410A (2088 x 1).

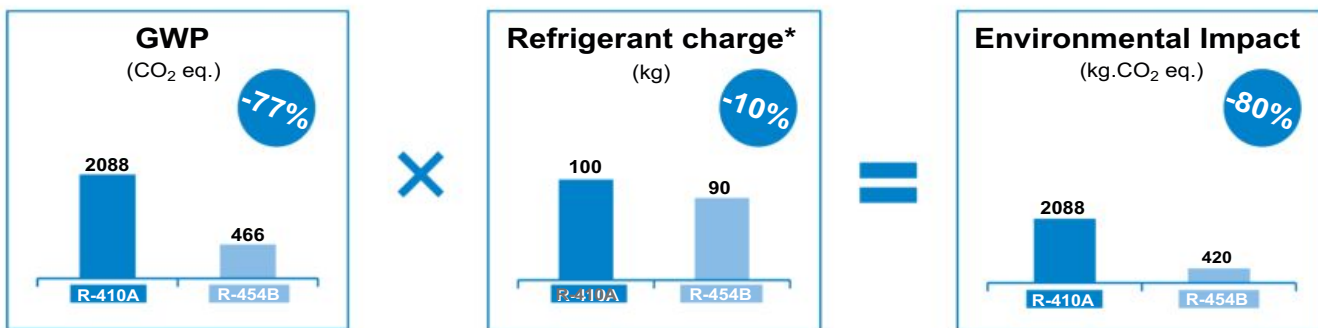

Note: Units with R-410A can benefit from a retrofit kit to use R-454B.

### Indirect effect. Lower environmental impact ⇒ -3% compared to the already astonishing low consumption in 50FC R-410A



**SEER up to +3%** (\*): Up to 42% savings vs ErP2021  
**SCOP up to +3%** (\*): Up to 10% savings vs ErP2021  
 (\*) over the already outstanding performance in 50FC R-410A

The seasonal efficiency of 50FF/FC R-454B is higher than the already outstanding performance in 50FC R-410A.

The savings vs Ecodesign requirements go up to 42% in cooling and 10% in heating with 50FF/FC R-454B.

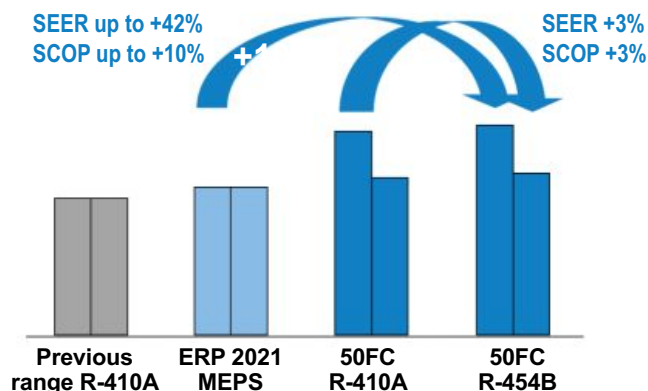

This performance is the result of the optimize and high quality components rigorously selected:

- R-454B refrigerant with high energy performance.
- New generation of scroll compressors optimized for R-410A and R-454B refrigerant (bivalent compressors) in tandem configuration with 2 frigorific circuits and 4 compressors for high performance in partial load.
- Electronic expansion valves.
- "50FC" control optimizing performance and energy consumption.
- Outdoor EC fans for high efficiency and low noise level.
- Indoor EC plug-fans with pressure transducer.

R-454B is an A2L classified refrigerant thanks to its low flammability.

- The service tools must be certified for A2L refrigerants in accordance with standard ISO 817 or EN378.
- Service technicians must be qualified for brazing components on PED 3 fluid units.





## UNIT COMPONENTS

### Casing

- Structure made of galvanised steel metal. Panels and registers in aluminium. Most parts protected with polyester paint, white colour RAL 7035.
- Removable panels for easy access to all components: electrical cabinet, compressors, fans, filters, etc.
- Skids for easy transport in a container. The dimensions of this range allow all models and assemblies to be transported in a container, so that the special SE14C maritime packaging is not necessary under any circumstances.

### Outdoor circuit

- Coils with copper pipes and aluminium fins.
- EC electronic axial fans which adapt the rotation speed to the installation's requirements, thereby reducing electricity consumption, the sound level at partial charge and improving the unit's average seasonal efficiency. IP55 protection.

### Indoor circuit

- Thermal and acoustic insulation in panels and registers with M1 fire classification.
- Coils with copper pipes and aluminium fins.
- EC electronic supply plug-fans with variable control speed and flow rate controller.  
The fans are factory configured with nominal air flow. Consult for any special configuration.
- Reusable gravimetric air filters G4, mounted on a frame. Dual locking system mounted on the access panel to filters.
- Isolated pan of condensates drainage sloping down towards the drain. This pan is removable for easy cleaning in models 100 to 170.

### Cooling circuit

- Hermetic scroll-type compressors in tandem design that

improves the management of stages and the part load efficiencies, assembled over antivibration mounts. Relay for phase-sequence monitoring and phase loss protection.

- Crankcase heater.
- Electronic expansion valves.
- Four-way cycle reversing valves.
- Acid-resistant filters dryer.
- Cooling design in 2-air volumes.

### Protections

- High pressure pressostats.
- High and low pressure transducers.
- Refrigerant leak control (by low-pressure alarm).
- Due to the A2L category of refrigerant R-454B (lightly flammable), it requires the installation of a refrigerant leak detector. This detector uses infrared instead of semiconductor technology with no need of calibration (self-calibration), with very fast time response, and high lifetime.  
The detector is installed on a panel next to the supply fans of the indoor circuit. This position ensures the correct reading of the gas concentration in the indoor coil.

If the unit is connected to a BMS monitoring system, the electronic control is prepared to send an alarm signal in case of leakage detection.

Note: These units are designed to be installed outdoors in a well ventilated area, but a second leak detector can be installed in the outdoor circuit if in any case it is considered necessary. Available upon request.

- Compressor discharge temperature control.
- Main door switch.
- Protection for power lines of compressors with manual motor starters and power lines of fan motors with magnetothermic switches. These devices provide protection against overload, short circuit, phase failure and undervoltage.
- Automatic switch in the control circuit.



## UNIT COMPONENTS

### Electrical cabinet

- Complete and fully wired electrical cabinet. Insulated access door to prevent condensation. Forced ventilation of the electrical cabinet. Protection IP54.
- Numeration of wired and identification of components in the electrical cabinet. It permits easy tracing and diagnostics.
- Hinges + quarter-turn latches on the removable access doors.
- Electrical power supply with neutral.
- Main ground connection.
- Compressor and fan motor contacts.

### “50FC” electronic control

The "50FC" control consist of a control board, sensors, a graphic terminal and a user terminal (optional).

This system includes a RS485 field-bus to manage additional components such as: expansion modules and boards, plug-fans, probes of temperature or relative humidity of the ambient air, leak detectors, energy meters, etc.

This board also integrates two communication ports that allow connection with a centralized technical management system such as BOSS and BOSS mini. A BMS port for Modbus RTU protocol and an Ethernet port for Modbus TCP/IP protocol.

A communication card (optional) can also be connected to the board for the following protocols: BACnet™ MSTP, BACnet™ Ethernet, Modbus RTU, Konnex, TCP/IP, SNMP V1-2-3, FTP y HTTP.

The "50FC" control enables unit integration with our local supervision solutions: pCO Web (1 unit), BOSS mini (50 units) and BOSS (300 units), as well as with the remote solution: ABOUND HVAC Performance.

With this control, it is also possible to connect to a shared network (SHRD) for a maximum of 15 units, with one unit configured as "Master" and the other units as "Slaves". This network allows the exchange of data and information between the units, and depending on the conditions of the installation, it can share the reading of some probes installed on the unit configured as "Master", temperature setpoints, and operating mode. It is also possible to configure one unit as a "Backup", for activation in case of malfunction of the other unit.

- The main functions of this control are:
    - Selection of setpoint and operating mode: HEATING / COOLING / AUTO / VENTILATION.
    - Continuous control of the operating parameters.
    - Display of the values measured by the sensors.
    - Compressors cycles.
    - Defrosting management.
    - Control of the supply air temperature.
    - All-seasons operation via the condensation and evaporation pressure control.
- The management of the unit in cooling mode is based on the principle of a high floating pressure. The condensation pressure setpoint is continually calculated depending on the outdoor temperature. This pressure is regulated by adjusting the air flow on the outdoor fans.
- Setpoint compensation based on the outdoor temperature.
  - Hourly and weekly schedule.
  - Fire protection.
  - Diagnosis of faults and general alarm.

- Management of all the optional components available for the unit: economizer, Backup heating, CO<sub>2</sub> air quality sensor, energy recovery,...

### User interfaces

#### Graphic terminal

This terminal, fitted as standard on the electrical cabinet, is very easy to use. It provides detailed explanations of control in easy to understand English. No decoding is required.

Only 6, large, easy-to-use buttons are required to maneuver through the entire menus.

- This terminal is used to:
  - Carry out initial programming of the unit.
  - Modify operating parameters.
  - Switch the unit ON / OFF.
  - Select the operating mode and adjust the setpoints.
  - Display the variables controlled and sensor values measured.
  - Display the current alarms and their historical record.



Note: multiple units can share a single terminal, if they are integrated into a pLAN local network (for up to 15 units).

#### User terminal (optional)

This terminal can be installed on the electrical cabinet, instead of the graphic terminal. In this case, the remote connection of the graphic terminal is possible.

- This terminal is used to:
  - Switch the unit ON / OFF.
  - Select the operating mode and adjust the setpoints.
  - Display the installation's temperatures and humidity, outdoor temperature, supply air temperature, CO<sub>2</sub> sensor and opening of the outdoor damper.
  - Display alarms codes.



#### Touch panel (optional)

With the same functions as the graphic terminal, the 4.3 inch touchscreen panel makes interaction between the user and the unit much easier by simplifying navigation between the various screens.



## PHYSICAL DATA WITH R-454B REFRIGERANT (EN-14511-2022)

50FF		100	110	120	130	145	160	170	180	200	220	250	280
<b>Cooling capacities</b>													
Cooling capacity (1)	kW	97,4	107	116	126	141	155	163	175	194	212	245	265
Power input (3)	kW	29,4	33,1	36,6	37,6	44,2	50,5	54,5	52,2	61,0	70,2	74,5	84,9
EER performance		3,31	3,23	3,17	3,35	3,19	3,07	2,99	3,35	3,18	3,02	3,29	3,12
SEER		5,10	4,93	4,84	5,08	4,91	4,86	4,87	5,19	5,01	5,00	4,90	4,85
ηs		201%	194%	191%	200%	193%	191%	192%	205%	198%	197%	193%	191%
<b>Outdoor circuit fan</b>													
Electronic axial fan													
Nominal air flow	m <sup>3</sup> /h	44.000	44.000	44.000	58.000	58.000	64.000	64.000	80.000	86.000	86.000	120.000	120.000
Available static pressure	mm.w.c	5											
Number / Diameter	mm	2 / 800			2 / 910				4 / 800			4 / 910	
Maximum speed	r.p.m.	1.100			1.070				1.100			1.070	
Motor output	kW	2 x 3,0			2 x 3,3				4 x 3,0			4 x 3,3	
Maximum absorbed current	A	2 x 4,6			2 x 5,0				4 x 4,6			4 x 5,0	
<b>Indoor circuit supply fan</b>													
Electronic plug-fan (Polypropylene) (1)													
Nominal air flow	m <sup>3</sup> /h	18.000	19.800	21.600	23.400	26.100	28.800	30.600	32.400	36.000	39.000	40.500	45.000
Nominal avail. static pressure	mm.w.c	25	25	25	30	35	35	35	35	35	35	35	35
Minimum air flow	m <sup>3</sup> /h	10.800			14.040				19.440			24.300	
Maximum air flow	m <sup>3</sup> /h	25.920			36.720				46.800			54.000	
Number / Diameter	mm	3 / 500			4 / 500				5 / 500			6 / 500	
Speed	r.p.m.	1.800			1.800				1.800			1.800	
Motor output	kW	3 x 3,1			4 x 3,1				5 x 3,1			6 x 3,1	
Maximum absorbed current	A	3 x 4,7			4 x 4,7				5 x 4,7			6 x 4,7	
<b>Compressor</b>													
Scroll													
No. compressors / stages / circuits		4 / 4 / 2											
Oil type		Copeland 3MAF 32cST, Danfoss POE 160SZ, ICI Emkarate RL 32CF, Mobil EAL Artic 22CC											
Volume of oil	l	4 x 3,0	2 x 3,0 + 2 x 3,3	4 x 3,3	4 x 3,3	4 x 3,3	4 x 3,3	2 x 3,3 + 2 x 3,6	2 x 3,3 + 2 x 3,6	3 x 3,6 + 1 x 6,1	1 x 3,6 + 3 x 6,1	4 x 6,1	4 x 6,1
<b>Electrical characteristics</b>													
Mains voltage		400 V / III ph / 50 Hz (±10%)											
Power supply		3 Wires + Ground + Neutral											
Maximum absorbed current	A	80,0	84,6	94,6	100,7	117,3	126,6	133,7	146,8	162,6	180,0	202,1	223,4
<b>Refrigerant</b>													
R-454B													
Global warming potential (4)	GWP	466											
Charge	kg	31,0	31,0	31,0	34,0	34,0	34,5	35,0	49,0	51,0	51,0	61,0	62,0
Environment impact	tCO <sub>2</sub> eq	14,4	14,4	14,4	15,8	15,8	16,1	16,3	22,8	23,8	23,8	28,4	28,9
<b>Weight</b>													
B1 assembly	kg	1.430	1.450	1.470	1.640	1.680	1.690	1.700	2.265	2.370	2.475	2.795	2.860

- (1) Cooling capacity calculated in accordance with the EN-14511-2022 standard given for indoor temperature conditions 27°C, 19°C WB and 35°C outdoor temperature  
(3) Total power input by compressors and motorised fans under nominal conditions, calculated in accordance with the EN-14511-2022 standard  
(4) Climatic warming potential of a kilogram of fluorinated greenhouse gas in relation to a kilogram of carbon dioxide over a period of 100 years  
(5) Or metallic equivalent fan model

### Compliance

- Machinery Directive 2006/42/EC (MD)
- Electromagnetic Compatibility Directive 2014/30/EU (EMC)
- Pressure Equipment Directive 2014/68/EU (Category 3) (PED)
- RoHS Directive 2011/65/EU (RoHS)
- Eco-design Directive 2009/125/EC (ECO-DESIGN)
- Energy Labelling Directive 2017/1369/EU (ECO-LABELLING)
- Harmonised Standard: EN 378-2:2012 (Refrigerating systems and heat pumps - Safety and environmental requirements).



Eurovent  
certified  
values

**PHYSICAL DATA WITH R-454B REFRIGERANT (EN-14511-2022)**

50FC		100	110	120	130	145	160	170	180	200	220	250	280
<b>Cooling capacities</b>													
Cooling capacity (1)	kW	97,7	107	116	126	141	155	163	176	195	215	247	273
Power input (3)	kW	30,2	34,2	37,8	40,0	45,8	52,4	56,6	54,0	63,3	73,9	79,2	91,9
EER performance		3,24	3,13	3,07	3,15	3,08	2,96	2,88	3,26	3,08	2,91	3,12	2,97
SEER		4,91	4,79	4,69	4,91	4,76	4,71	4,72	5,04	4,86	4,84	4,75	4,70
$\eta_s$		193%	188%	185%	193%	187%	185%	186%	198%	191%	191%	187%	185%
<b>Heating capacities</b>													
Heating capacity (2)	kW	97,2	107	118	127	144	158	166	184	203	228	271	298
Power input (3)	kW	26,6	29,9	33,9	34,8	40,1	45,4	48,3	48,7	55,9	64,6	74,5	85,1
COP performance		3,66	3,58	3,48	3,65	3,59	3,48	3,44	3,78	3,63	3,53	3,64	3,50
SCOP		3,53	3,53	3,51	3,51	3,49	3,44	3,45	3,47	3,46	3,47	3,46	3,44
$\eta_s$		138%	138%	137%	137%	137%	135%	135%	136%	135%	136%	135%	135%
<b>Outdoor circuit fan</b>													
Electronic axial fan													
Nominal air flow	m <sup>3</sup> /h	44.000	44.000	44.000	58.000	58.000	64.000	64.000	80.000	86.000	86.000	120.000	120.000
Available static pressure	mm.w.c	5											
Number / Diameter	mm	2 / 800			2 / 910				4 / 800			4 / 910	
Maximum speed	r.p.m.	1.100			1.070				1.100			1.070	
Motor output	kW	2 x 3,0			2 x 3,3				4 x 3,0			4 x 3,3	
Maximum absorbed current	A	2 x 4,6			2 x 5,0				4 x 4,6			4 x 5,0	
<b>Indoor circuit supply fan</b>													
Electronic plug-fan (Polypropylene) (1)													
Nominal air flow	m <sup>3</sup> /h	18.000	19.800	21.600	23.400	26.100	28.800	30.600	32.400	36.000	39.000	40.500	45.000
Nominal avail. static pressure	mm.w.c	25	25	25	30	35	35	35	35	35	35	35	35
Minimum air flow	m <sup>3</sup> /h	10.800			14.040				19.440			24.300	
Maximum air flow	m <sup>3</sup> /h	25.920			36.720				46.800			54.000	
Number / Diameter	mm	3 / 500			4 / 500				5 / 500			6 / 500	
Speed	r.p.m.	1.800			1.800				1.800			1.800	
Motor output	kW	3 x 3,1			4 x 3,1				5 x 3,1			6 x 3,1	
Maximum absorbed current	A	3 x 4,7			4 x 4,7				5 x 4,7			6 x 4,7	
<b>Compressor</b>													
Scroll													
No. compressors / stages / circuits		4 / 4 / 2											
Oil type		Copeland 3MAF 32cST, Danfoss POE 160SZ, ICI Emkarate RL 32CF, Mobil EAL Artic 22CC											
Volume of oil	l	4 x 3,0	2 x 3,0 + 2 x 3,3	4 x 3,3	4 x 3,3	4 x 3,3	4 x 3,3	2 x 3,3 + 2 x 3,6	2 x 3,3 + 2 x 3,6	3 x 3,6 + 1 x 6,1	1 x 3,6 + 3 x 6,1	4 x 6,1	4 x 6,1
<b>Electrical characteristics</b>													
Mains voltage		400 V / III ph / 50 Hz ( $\pm 10\%$ )											
Power supply		3 Wires + Ground + Neutral											
Maximum absorbed current	A	80,0	84,6	94,6	100,7	117,3	126,6	133,7	146,8	162,6	180,0	202,1	223,4
<b>Refrigerant</b>													
R-454B													
Global warming potential (4)	GWP	466											
Charge	kg	31,0	31,0	31,0	34,0	34,0	34,5	35,0	49,0	51,0	51,0	61,0	62,0
Environment impact	tCO <sub>2</sub> eq	14,4	14,4	14,4	15,8	15,8	16,1	16,3	22,8	23,8	23,8	28,4	28,9
<b>Weight</b>													
B1 assembly	kg	1.430	1.450	1.470	1.640	1.680	1.690	1.700	2.265	2.370	2.475	2.795	2.860

- (1) Cooling capacity calculated in accordance with the EN-14511-2022 standard given for indoor temperature conditions 27°C, 19°C WB and 35°C outdoor temperature  
 (2) Heating capacity calculated in accordance with the EN-14511-2022 standard given for indoor temperature conditions 20°C and 6°C WB outdoor temperature  
 (3) Total power input by compressors and motorised fans under nominal conditions, calculated in accordance with the EN-14511-2022 standard  
 (4) Climatic warming potential of a kilogram of fluorinated greenhouse gas in relation to a kilogram of carbon dioxide over a period of 100 years  
 (5) Or metallic equivalent fan model

**Compliance**

- Machinery Directive 2006/42/EC (MD)
- Electromagnetic Compatibility Directive 2014/30/EU (EMC)
- Pressure Equipment Directive 2014/68/EU (Category 3) (PED)
- RoHS Directive 2011/65/EU (RoHS)
- Eco-design Directive 2009/125/EC (ECO-DESIGN)
- Energy Labelling Directive 2017/1369/EU (ECO-LABELLING)
- Harmonised Standard: EN 378-2:2012 (Refrigerating systems and heat pumps - Safety and environmental requirements).



Eurovent certified values

## ECODESIGN REGULATIONS

### New metrics because seasonal efficiency matters

With all new buildings expected to be close to zero energy, calculations of the energy efficiency of buildings require accurate indicators of the efficiency of their equipment. These indicators must be representative of actual operations throughout the year, measuring the performance of equipment on a seasonal basis.

**EER & COP belong to the past.** Now, and in the future, the focus is on seasonal efficiency. With a broad new products range, Carrier is fully engaged to take up the challenge of energy efficiency.

**Compliance with the Ecodesign regulations therefore involves the use of new, more meaningful seasonal efficiency metrics.** The Seasonal Energy Efficiency Ratio (SEER), and Seasonal Coefficient of Performance (SCOP) all ensure precise evaluation of the energy actually consumed by rooftops, by including seasonal variations in their measurements. Previous metrics (EER & COP) measured operations only at a single point, at full thermal load, and were therefore less representative of consumption over entire heating and cooling seasons.

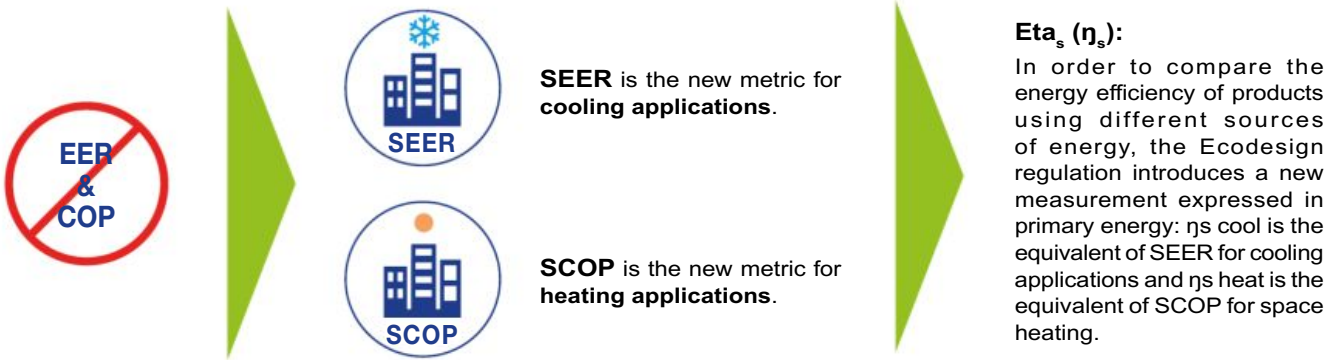

### Eta<sub>s</sub> (η<sub>s</sub>):

In order to compare the energy efficiency of products using different sources of energy, the Ecodesign regulation introduces a new measurement expressed in primary energy: η<sub>s</sub> cool is the equivalent of SEER for cooling applications and η<sub>s</sub> heat is the equivalent of SCOP for space heating.

These new seasonal performance metrics are now the key indicator used for rooftops, in all applications. They are calculated according to technical standard **EN 14825** and compliance is mandatory for a product to obtain CE marking.

### Confort cooling

#### SEER - Seasonal Energy Efficiency Ratio



SEER measures the seasonal energy efficiency of rooftops by calculating the ratio between annual cooling demand and annual energy input. It takes into account the energy efficiency achieved for each outdoor temperature weighted by the number of hours observed for each of these temperatures, using actual climate data.

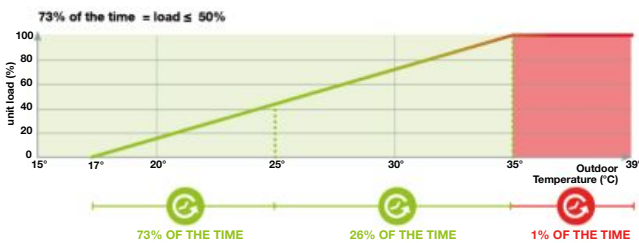

SEER is a new way of measuring the true energy efficiency of rooftops for cooling over an entire year.

This new indicator gives a more realistic indication of the real energy efficiency and environmental impact of a cooling system.

#### Efficiency requirements

Regulation 2016/2281 sets seasonal energy efficiency in Eta<sub>s</sub> cool (η<sub>s</sub> cool). This expresses SEER in terms of primary energy and so makes it possible to compare the energy efficiency of units using different energy sources.

Minimum η<sub>s</sub>SC (SEER) according regulation (EU) 2016/2281:

From 01/2018. Tier1		From 01/2021. Tier2	
η <sub>s</sub> SC %	SEER	η <sub>s</sub> SC %	SEER
117	3,00	138	3,53

### Space heating

#### SCOP – Seasonal Coefficient of Performance



SCOP measures the seasonal energy efficiency of rooftops by calculating the ratio between annual heating demand and annual energy input. It takes into account the energy efficiency achieved at each outdoor temperature of an average climate weighted by the number of hours observed for each of these temperatures.

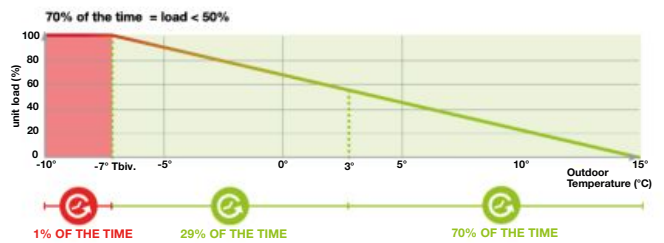

SCOP is a new way of measuring the true energy efficiency in heating mode over an entire year.

This new indicator gives a more realistic indication of the real energy efficiency and environmental impact of a heating system.

#### Efficiency requirements

Regulation 2016/2281 sets seasonal energy efficiency in Eta<sub>s</sub> heat (η<sub>s</sub> heat). This expresses SCOP in terms of primary energy and so makes it possible to compare the energy efficiency of units using different energy sources.

Minimum η<sub>s</sub>SH (SCOP) according regulation (EU) 2016/2281:

From 01/2018. Tier1		From 01/2021. Tier2	
η <sub>s</sub> SH %	SCOP	η <sub>s</sub> SH %	SCOP
115	2,95	125	3,20

The technical data sheets (TDS) for CARRIER units are available at [www.ecodesign.hvac.carrier.com](http://www.ecodesign.hvac.carrier.com)



## OPERATING LIMITS

Inlet air conditions		Cooling		Heating
		50FF	50FC	50FC
Indoor coil	Minimum temperature	9,7°C WB		10°C
	Maximum temperature	24°C WB		27°C
Outdoor coil	Minimum temperature	-10°C (1)		-15°C WB (2) (3)
	Maximum temperature	52°C	48°C	15°C WB

- (1) With the condensation pressure control disabled, operation up to 12°C.
- (2) When the outdoor temperature is usually below 5°C WB, the installation of a support element is recommended.
- (3) Operation up to -18°C WB at partial load

## SOUND LEVELS dB(A)

### Sound power level (LW)

50FF/FC	100	110	120	130	145	160	170	180	200	220	250	280
63 Hz	64,6	65,1	65,6	66,1	66,6	66,9	67,1	67,1	67,9	69,1	70,6	71,6
125 Hz	71,4	71,9	72,4	72,9	73,4	73,7	73,9	73,9	74,7	75,9	77,4	78,4
250 Hz	77,9	78,4	78,9	79,4	79,9	80,2	80,4	80,4	81,2	82,4	83,9	84,9
500 Hz	80,2	80,7	81,2	81,7	82,2	82,5	82,7	82,7	83,5	84,7	86,2	87,2
1000 Hz	80,6	81,1	81,6	82,1	82,6	82,9	83,1	83,1	83,9	85,1	86,6	87,6
2000 Hz	78,1	78,6	79,1	79,6	80,1	80,4	80,6	80,6	81,4	82,6	84,1	85,1
4000 Hz	74,2	74,7	75,2	75,7	76,2	76,5	76,7	76,7	77,5	78,7	80,2	81,2
8000 Hz	69,4	69,9	70,4	70,9	71,4	71,7	71,9	71,9	72,7	73,9	75,4	76,4
Total dB(A)	86,0	86,5	87,0	87,5	88,0	88,3	88,5	88,5	89,3	90,5	92,0	93,0

### Sound pressure level (LP)

Measurement conditions: in a clear field, measured at a distance of 5 metres, directivity 2 and at 1,5 metres from the ground.

50FF/FC	100	110	120	130	145	160	170	180	200	220	250	280
Total dB(A)	58,6	59,1	59,6	60,0	60,5	60,8	61,0	60,7	61,5	62,7	64,0	65,0

Note: The sound pressure level depends on the installation conditions and, as such, it only indicated as a guide. Values obtained according to the ISO 3744 standard.

## ELECTRICAL CONNECTIONS

No.	50FF/FC		100 to 280
1	Main power supply	400 III (±10%)	3 Wires + Ground + Neutral
2	Remote connection of graphic terminal (by default installed on the electrical cabinet) (1)		Telephone cable 6 wires standard (RJ12 connector)
3	Connection of user terminal (optional) (2)		2 wires for power supply 230V + 1 shielded cable for communication type AGW20 / 22 (1 braided pair + drainwire + shielding)
4	Remote off/on (optional)		2 wires
5	General fault signal (opt.) (3)		2 wires
6	Remote Cooling / Heating (optional upon request)		2 wires
7	Circulation pump signal for HWC (antifreeze safety) (opt.)		1 wire
8	Ambient sensor	NTC	2 wires
		RS485	5 wires (4)
9	CO <sub>2</sub> sensor (optional)		3 wires

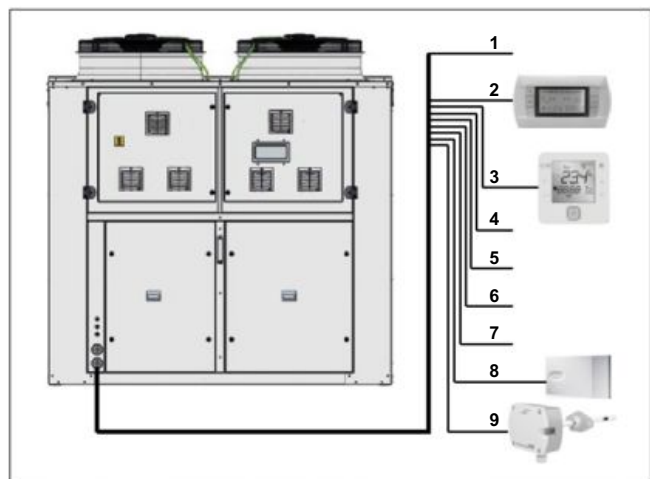

- (1) In this case, it's possible to install the user terminal on the electrical cabinet.
- (2) It's necessary that the terminal uses the same power supply that the control board.
- (3) The output for general alarm signal is not compatible with the following options: hot water coil, heat recovery coil, rotary heat exchanger and on/off signal for external humidifier. With these options, possibility of general alarm upon request.
- (4) Up to four RS485 ambient sensors can be connected in series on the fieldbus of the control board.



## FACTORY OPTIONS AND ACCESSORIES

Category	Description	Upon request	Factory installed option	Field installed accessory
Electrical power Airflow + Assembly	400 V / 3 ph / 50 (without neutral)		X	
	B2: Economizer, 2 dampers		X	
	BP: Plug-fan in return section		X	
	BA: Cooling recovery circuit with plug-fan in return section		X	
	BT: Return top box with plug-fan or centrifugal fan		X	
	BB: Cooling recovery circuit with plug-fan or centrifugal fan in return top box		X	
	BW: Heat recovery wheel module		X (*)	
	B3: Economizer, 3 dampers	X	X	
Coil coating	BL: Return top box with plug-fan or centrifugal fan with heat recovery wheel module	X	X (*)	
	INERA® coils with aluminium alloy fins and copper pipes		X	
	Coils with polyurethane pre-coated aluminium fins and copper pipes		X	
Heating	Blygold® coating	X	X	
	Auxiliary hot water coil: «Standard»		X	
	Auxiliary hot water coil: «Very low outdoor temperature»	X	X	
	Auxiliary electrical heaters: on/off control		X	
	Auxiliary electrical heaters: proportional control	X	X	
Protection low temperature	Warm air heater module with gas burner (supplied installed inside a pre-assembly roof curb)			X
	Freeze protection OAT lower than -10°C		X	
	Freeze protection OAT lower than -14°C		X	
	Freeze protection OAT lower than -10°C + spring shut-off dampers		X	
Supply fan	Freeze protection OAT lower than -14°C + spring shut-off dampers		X	
	Indoor plug-fan with nominal available pressure (Aluminum), low pressure (Aluminum) or high pressure (Aluminum)		X	
Air filtration + droplet eliminator	Droplet eliminator after the indoor air coil		X	X
	Filters G4 low pressure drop		X	X
	Filters G4 + folded filters F7		X	X
	Filters G4 low pressure drop + folded filters F7		X	X
	Double stage of folded filters: M6+F7, F7+F9		X	X
Outdoor fan	Two-speed direct-driven axial fans		X	
Insulation	Thermal and acoustic insulation, Euroclass A2-s1, d0 (M0), with double wall (50mm)		X	
Indoor circuit	Condensates drain pan in stainless steel		X	X
	Room overpressure management		X	
	Filter fouling detection with differential pressure switch		X	
Outdoor circuit	Fresh air safety grid		X	X
	Outdoor coil protection grid		X	X
	Droplet eliminator at the fresh air intake		X	X
	Antivibration mounts made of rubber		X	X
Heat recovery wheel	Selection of the heat recovery wheel (BW assembly): diameter, channel cross section, wheel material and type of speed control		X	
Extra heating	Heat recovery coil		X (*)	
Special applications	Air zoning		X (*)	
	Low return temperature application		X	
	Low return temperature application + Air zoning		X (*)	
Sensors	NTC ambient temperature sensor on the control board or 1 to 4 sensors with RS485 comm.		X	X
	Ambient temperature + humidity sensor with RS485 communication. Up to four sensors		X	X
	CO <sub>2</sub> sensor: environment or ducted installation or installed on a SHRD network		X	X
	Smoke detection control unit in accordance with the NF S 61-961 standard		X	X
Economizer + Outd. humidity	Economizer management: thermal, enthalpic or thermoenthalpic		X	X
	Outdoor air humidity sensor: supplied with the unit or installed on a SHRD network		X	X
Terminal + Unit communication	Graphic terminal installed in the electrical cabinet + User terminal remote up to 100 m		X	X
	Graphic terminal installed in the electrical cabinet + Graphic terminal remote up to 200 m		X	X
	User terminal installed in the electrical cabinet		X	X
	User terminal installed in the electrical cabinet + Graphic terminal remote up to 200 m		X	X
	Touch panel in the electrical cabinet		X	X
	Touch panel in the cabinet + Graphic terminal remote up to 200 m		X	X
	Touch panel in the cabinet + User terminal remote up to 100 m		X	X
	Unit configuration: stand-alone, master or slave		X	X
	Communication cards: RS485 Modbus/Carel; Ethernet PCoWeb; RS485 LonWorks®; Ethernet BACnet™; RS485 BACnet™; RS485 Konnex		X	X
	Miscellaneous item 1	Management of an humidifier with on-off or proportional control		X
Electrical energy meter			X	
Cooling capacity and electrical energy meter			X	
Miscellaneous item 2	Varnish protection for components on the electrical cabinet: control board, cards and terminals		X	
Return fan	Centrifugal return fan: 3 airflow options: low, nominal and high		X	
	Return plug-fan: 3 available pressure options: nominal pressure (Polypropylene), nominal pressure (Aluminium) or high pressure (Aluminium)		X	
Airflow direction	There are 9 combinations in the direction of airflow with: - Supply: lower, lateral and upper - Return: lower, lateral and upper		X	
Roof curb	Pre-assembly roof curbs with adjustable height			X
	Adaptation roof curbs for replacing units on site	X		X

(\*) Part of this option must be installed on-site.

## FACTORY OPTIONS AND ACCESSORIES

### Assembly + Indoor air flow direction

**B1 assembly**

Standard

**BW assembly**

Plug-fan in return section + Heat recovery wheel module (passive recovery)

**B2 assembly**

Economizer, 2 dampers: fresh air damper interlocked with return damper

**BT assembly**

Return top box with plug-fan or centrifugal fan

**BP assembly**

Plug-fan in return section

**BB assembly**

Return top box with plug-fan or centrifugal fan + Cooling recovery circuit (active recovery)

**BA assembly**

Plug-fan in return section + Cooling recovery circuit (active recovery)

**BL assembly (upon request)**

Return top box with plug-fan or centrifugal fan + Heat recovery wheel module (passive recovery)

**B3 assembly (upon request)**

Economizer, 3 dampers: fresh air damper and exhaust air damper

**Legend**

<b>S</b> Lower air supply	<b>R</b> Lower air return
<b>S'</b> Lateral air supply	<b>R'</b> Lateral air return
<b>S''</b> Upper air supply	<b>R''</b> Upper air return
<b>F</b> Fresh air intake	<b>E</b> Exhaust air outlet

Note: only one of the three possible options (lower, lateral or upper) can be selected for both, supply and return.

**Indoor airflow direction**

<b>0</b> Lower supply and lower return	<b>3</b> Lateral supply and lateral return	<b>6</b> Upper supply and lateral return
<b>1</b> Lateral supply and lower return	<b>4</b> Upper supply and lower return	<b>7</b> Lower supply and upper return
<b>2</b> Lower supply and lateral return	<b>5</b> Lateral supply and upper return	<b>8</b> Upper supply and upper return

## FACTORY OPTIONS AND ACCESSORIES

### Air pressure control in different assemblies

In case of assemblies with fresh air (ventilation) but without extraction air, overpressure will be generated in the building, higher with higher fresh air ratios or in free-cooling mode. It will not generate any issue in buildings with low air tightness and/or with doors frequently opened, but we should prevent in other applications. In assemblies with extraction damper and return fans, this overpressure can be completely avoided (pressure balance), or even controlled with a certain value to prevent infiltrations.

**50FF/FC** is the rooftop with the largest offer in airflow configurations to be able to adapt the unit to any kind of application or request. Please, find below comments and recommendations for each assembly.

Assembly	Fresh air and free-cooling	Return fans	Energy recovery (extraction)	Pressure control	Comments and recommendations
B1		No	No	No control required	Only for building with <b>no need of fresh air</b> . Pressure balance by default. Same return and supply airflow.
B2		Yes	No	No control	Adequate just for buildings with medium or low <b>air tightness</b> and/or doors frequently opened.
B2 + gravity dampers in the building		Yes	No	High control	Building overpressure is maintained at the same level than pressure drop before the gravity damper. No limitations in the return pressure drop.
B3 (upon request)		Yes	No	Medium control	Recommended only with <b>low pressure drop in the return ductwork</b> (maximum 50 Pa). The maximum building overpressure is at the same level than pressure drop in the return ductwork.
BA, BB, BL (upon request)		Yes	Yes	Yes, Active recovery	Return and supply EC plug-fan(s) are always supplied with pressure sensor to adjust the airflow. To manage <b>pressure balance</b> , supply and return are configured with same airflow. In case <b>overpressure</b> want to be managed (to avoid infiltration), the return airflow need to be lower than the supply. Differences <b>up to 10%</b> can be always being configured.
BP, BT		Yes	Yes	No	Additional overpressure with airflow differences <b>up to 20%</b> are possible <b>adding the option "overpressure control"</b> (*) which manages fresh and exhaust dampers independently.
BW		Yes	Yes	Yes, Passive recovery (wheel)	To maintain overpressure in case of variable fresh air management (with CO <sub>2</sub> sensor option), minimum fresh air ratio need to be configured.

(\*) This overpressure option is not available on BA, BB and BL assemblies because this type of control of the dampers penalizes cooling recovery.

#### Example:

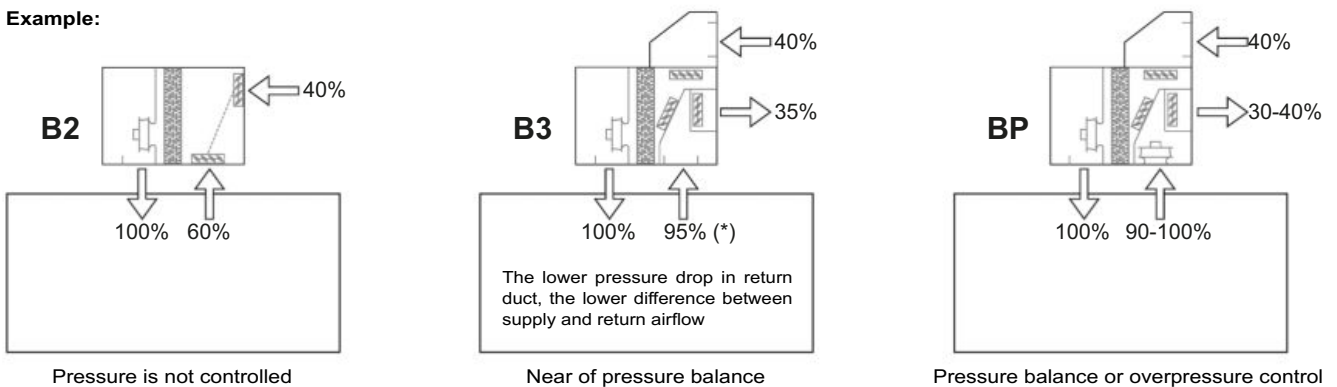

## FACTORY OPTIONS AND ACCESSORIES

### Electrical power

- These units can be supplied for the following power supply voltages:
  - 400 V / 3 ph + N / 50 Hz (standard)
  - 400 V / 3 ph / 50 Hz (optional)

### Coils coating

- Coils with copper pipes and aluminium fins with **polyurethane** coating. Level of corrosion protection: basic. This treatment offers a resistance of more than 1000 hours (ASTM B117 NSST).
- Coils with copper pipes and fins of an aluminium alloy **INERA®**. Level of corrosion protection: basic - medium. This treatment offers a resistance of more than 1000 hours (ASTM B117 NSST).
- Blygold®** coating (**upon request**). Level of corrosion protection: medium. This treatment offers more protection than 11000 hours in salt spray test (ASTM B117 NSST) and 4000 hours in acid salt spray test.

For further detailed information, please contact our Customer Service Department.

Note: These coating can be applied to various coils (outdoor, indoor and hot water coil) according to the combinations available in the "Selection Software".

### Heating

The unit only can incorporate one of these heating elements:

- Warm air heater module with gas burner** with modulating actuator, in accordance with the Gas Directive 2009/142/EC, installed inside a pre-assembly roof curb.

The 50FF/FC unit with lower air supply will be placed on this roof curb.



Note: It's recommended to use the filter fouling detector (optional) in units with gas burner.

Two values of power available for each model:

50FF/FC	100 to 120	130 to 170	170 to 280
BAM (Nominal)	PCH080	PCH130	PCH160
BAS (High)	PCH130	PCH160	PCH210

- Auxiliary electrical heaters**, with two power stages and on/off control, for assembly and connection inside the unit.

Up to 3 values of total power available for each model:

50FF/FC	RAF (Low)	RAM (Nominal)	RAS (High)
100 to 120	27 kW	36 kW	54 kW
130 to 170	36 kW	54 kW	72 kW
180 to 220	45 kW	72 kW	90 kW
250 to 280	54 kW	72 kW	108 kW

- Electrical heater with proportional control (**upon request**).

- Auxiliary hot water coil**, with three-way valve and proportional control, for assembly inside the unit.

The unit incorporates a freeze protection thermostat.

- Optional «Very low outdoor temperature» (**upon request**):

Additional freeze protection technology based on the water temperature. This protection is made up of a circulation pump as well as two sensors inserted in the input and the output of the coil.

Important: this option is mandatory for an outdoor temperature lower than -20°C WB. Consult for percentages of glycol water above 20%.

### Protection for low outdoor temperature

- Freeze protection OAT lower than -10°C. Mandatory for an outdoor temperature lower than -10°C WB.

- Electrical heater for protection of the components of the electrical cabinet.

- Compressor with protection for low temperature.

- Freeze protection OAT lower than -14°C. Mandatory for an outdoor temperature lower than -14°C WB.

In addition to the options of -10°C, this includes:

- Reinforced electrical heater for protection of the components of the electrical cabinet.

- Electrical heater for anti-freeze protection of dampers of the economizer (if applicable).

- Protective kit of the gas burner for low temperature (if applicable).

- Freeze protection OAT lower than -10°C + spring shut-off dampers in case of a power failure.

- Freeze protection OAT lower than -14°C + spring shut-off dampers in case of a power failure.

### Supply fan

- By default, these units are fitted with plug-fans for a nominal available pressure (N), in Polypropylene.

The following fans can optionally be supplied:

- F: Low available pressure (Aluminium)
- M: Nominal available pressure (Aluminium)
- S: High available pressure (Aluminium)

Note: Aluminium fans are rated A2-s1, d0 (M0) and comply with regulations for public promises in France.



## FACTORY OPTIONS AND ACCESSORIES

Note: The fans are factory configured with nominal air flow. Consult for any special configuration.

Important: the "Selection Software" will choose the supply fan with lower consumption for the available pressure required.

### Air filtration + Droplet eliminator

Options to improve indoor air quality:

- Different combinations of filters are available:
  - Gravimetric filters G4 with low pressure drop.
  - Gravimetric filters G4 of standard type + folded opacimetric filters F7.
  - Gravimetric filters G4 with low pressure drop + folded opacimetric filters F7.
  - Double-stage of folded opacimetric filters: M6+F7 or F7+F9.

Classification of these filters according to the new **ISO 16890 Standard**:

- G4 → ISO Coarse 60%
- M6 → ISO ePM10 70%
- F7 → ISO ePM1 50%
- F9 → ISO ePM1 80%

- Droplet eliminator after the indoor air coil. Recommended in cases where a high moisture content in the air is foreseen or when the air flow is high.

Note: with hot water coil it is not possible to assemble the droplet eliminator.

### Outdoor fan

- Two-speed direct-driven axial fan(s). Watertight motor class F, IP54 and internal thermal protection. Dynamically balanced propellers and outdoor protective grille.

### Insulation

- Thermal and acoustic insulation A2-s1,d0 (M0) with sandwich panels with double wall, 50 mm thick, in all indoor section in contact with airflow.



Standard insulation



M0 insulation

Optionally, the fresh air damper and the exhaust damper can be managed independently for greater airflow differences. This option may be necessary to prevent the entry of outside air (BP, BT and BW assemblies).

Note: This option is not available on BA and BB assemblies because this type of control of the dampers penalizes cooling recovery.

### Outdoor circuit

- Fresh air safety grid (9x9mm).
- Outdoor coil protection grid.
- Antivibration mounts made of rubber.
- Droplet eliminator at the fresh air intake. This one and the thermoenthalpic free-cooling are necessary in cases where a high moisture content in the air is foreseen.

### Heat recovery wheel

- The heat recovery wheel is fitted into a module placed on one side of the unit. This module is supplied disassembled with the unit, for installation on site.

Available with BW assembly, and upon request, with BL assembly.

This rotary recovery unit is used to transfer the sensible and latent heat from the air-conditioned room's return air to the fresh air used for ventilation, before it's discharged outdoors. This option reduces the compressors runtime, ensuring energy saving and benefiting the environment.

The efficiency of energy recovery depend on the wheel selected: material, wheel diameters, channel cross section and type of speed control.

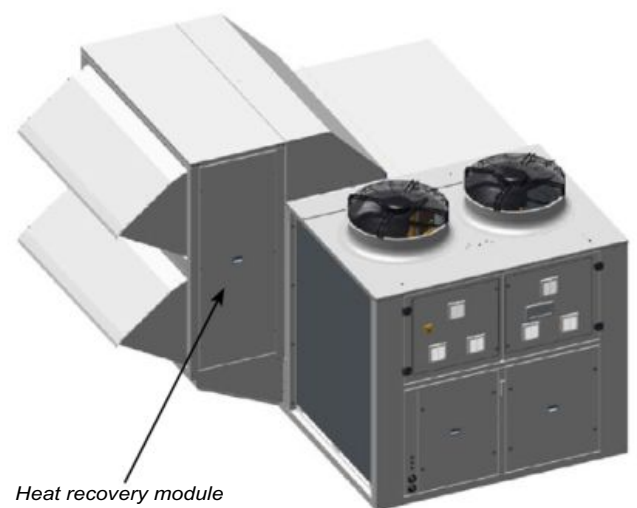

### Indoor circuit

- Condensate drain pan in stainless steel for corrosion protection.
- Filter fouling detection with differential pressure switch.
- Room overpressure management. Assemblies that include a return fan allow the management of airflow differences between supply air and return air of up to 10%, setting up flow setpoints.

### Extra heating

- Heat recovery coil (HRC). The coil function is to pre-heat the air that will pass through the main indoor coil. For this, it uses the temperature of an outdoor water installation.

The coil is supplied with a 3-way valve for installation outside the unit but manages by the electronic control.

This option is compatible with B1, B2, BT and BB assemblies.



## FACTORY OPTIONS AND ACCESSORIES

### Special applications

- Low return temperature application.** This option is mainly focused to food storage, and can be applied to large warehouses installations.

With this option, the unit adapts all its devices to manage low return temperature (15°C) in cooling mode. This is possible due to some changes in the control operation parameters.

The "Selection Software" includes the option as mandatory when return temperature is lower than 20°C (with 15°C as the minimum allowed value).

- Zoning of the air flow** up to 4 different zones.

This option allows the management of the air flow of the unit to condition up to 4 different zones with a minimum air flow of 35% (all of them in same operating mode: heating or cooling). This function allows to adapt the indoor air flow to the installation requirements.

Note: zoning is only possible with plug-fans.

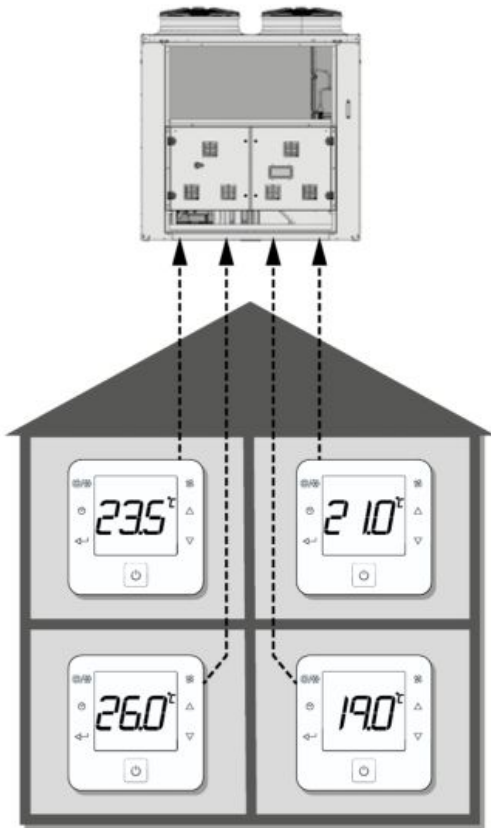

Regulation gives the control signal to the dampers installed in each zone (dampers and servomotors for those dampers not supplied). The unit modifies the air flow and capacity depending on information coming from sensors in each zone and considering active zones in each moment.

The option includes 4 zone terminals (one for each zone) and a control board supplied in an independent box. The 4 terminals, the PJ unit main board and also the servomotors that control dampers in each zone are connected on this board (dampers and servos not supplied).

The temperature information for each zone is coming from temperature sensor integrated inside each zone terminal. It is not needed to install any extra ambient sensor.

Note: In case the unit includes an economizer for enthalpic or thermoenthalpic free cooling (T+H control) an extra return T+H sensor in the offer is required. If the unit additionally includes CO<sub>2</sub> probe, it must be a return probe and not an ambient probe.

In following picture, electronic PCB and 4 zone terminals are detailed. Connections can be found in the "50FC" control manual.

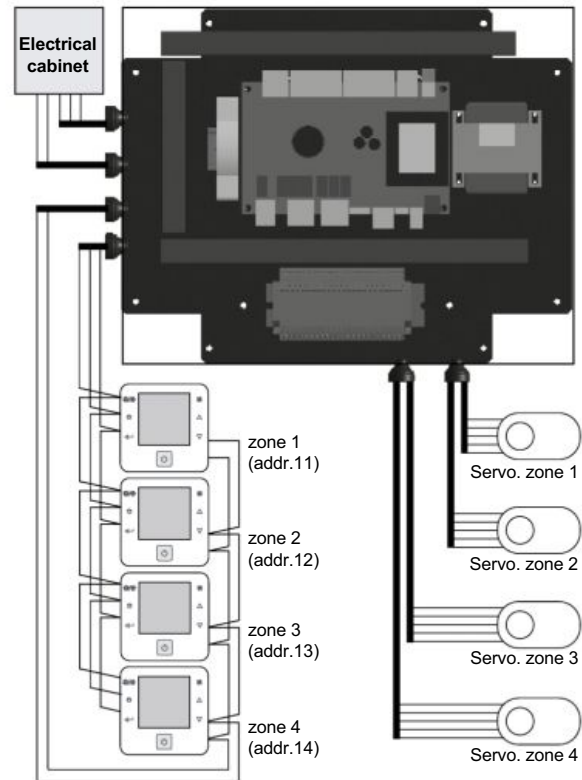

Note: There is a new option with **constant supply pressure** that extends the possibilities for multi-zone management. Available upon request.

### Sensors

- Ambient temperature sensor(s).** There are 3 options:
  - One NTC sensor connected to the control board.  
Note: An ambient sensor with RS485 communication is required for installation at more than 30 meters.
  - Up to four sensors with RS485 communication.
  - Sensor(s) installed on the master unit of the shared network (SHRD).
- One to four ambient temperature + humidity sensor(s)** with RS485 communication or installed on the SHRD network. This sensor is compulsory in units with enthalpic or thermoenthalpic free-cooling (optional). In this case, the outdoor air humidity sensor is also added.
- CO<sub>2</sub> sensor for air quality control.** There are 3 options:
  - Ambient air quality sensor,
  - Return air quality sensor (duct-mounted),
  - Sensor installed on the master unit of the shared network (SHRD).
- Smoke detection control unit** in accordance with the NF S 61-961 standard, that uses a LED to indicate the installation status, and if the probe detects the presence of smoke in the installation, it stops the operation of the unit and gives the order to open or close the outdoor damper (configured by parameter).

To ensure compliance with the French regulations on Fire safety (ERP), it's possible to select the opening of the fresh air damper and the exhaust air damper to 100% (return air damper closed).

## FACTORY OPTIONS AND ACCESSORIES

### Economizer management + outdoor humidity

Managing free-cooling with an **economizer** allows to make best use of outdoor air conditions when these are more favourable than the return air conditions. This allows the cooling capacity to be reduced. The percentage of outdoor air can vary between 0% and 100%.

The economizer management can be:

- Thermal, by comparing the temperatures.
- Enthalpic, by comparing the enthalpies. Recommended in cases where a high moisture content in the air is foreseen.
- Thermoenthalpic, by comparing the enthalpies and correcting for temperature. This is the optimum solution as it takes the variability of the climate into account.

Thermal free-cooling

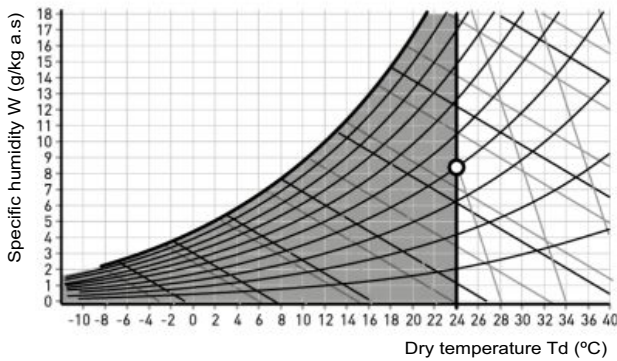

Enthalpic free-cooling

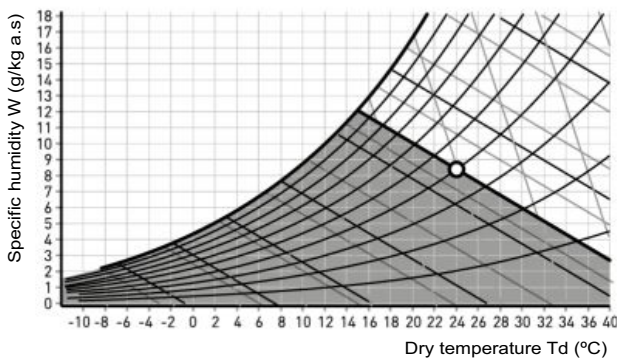

Thermoenthalpic free-cooling

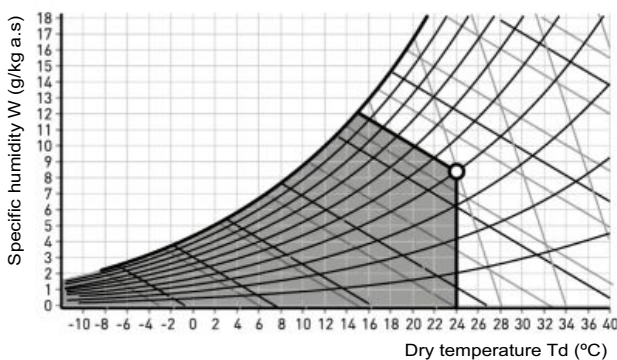

One function that helps improve energy management is **nocturnal free-cooling**. This feature allows the compressors to be disabled in summer with programming, the unit works providing free-cooling at night, when the outdoor conditions are favourable. This allows the cooling demand to decrease significantly early in the day.

■ **Outdoor air humidity** sensor (compulsory in units with optional enthalpic or thermoenthalpic free-cooling).

There are 2 options:

- Sensor supplied with the unit.
- Sensor installed on another unit of the shared network (SHRD).

### Terminal + unit communication

■ By default, the electronic control is supplied with a graphic terminal installed in the electrical cabinet of the unit, but these other configurations also are available:

- Graphic terminal installed in the electrical cabinet and User terminal remote up to 100 meters.
- Graphic terminal installed in the electrical cabinet and Graphic terminal remote up to 200 meters (two TCONN bypass cards must be used from 50 to 200 meters).
- User terminal installed in the electrical cabinet, instead of the graphic terminal.
- User terminal installed in the electrical cabinet and Graphic terminal remote up to 200 meters (two TCONN bypass cards must be used from 50 to 200 meters).

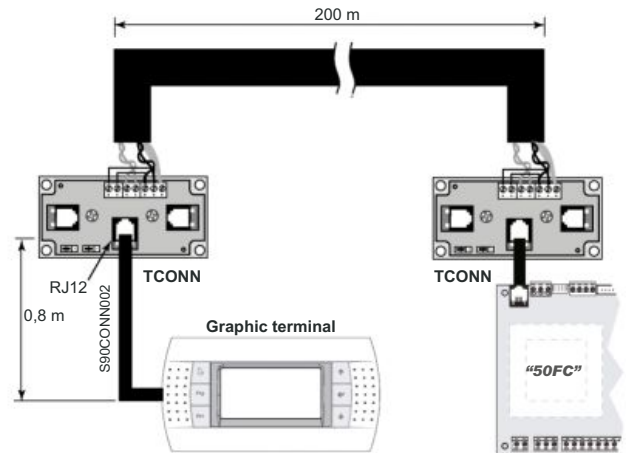

- Touch panel installed in the electrical cabinet, instead of the graphic terminal.
- Touch panel installed in the electrical cabinet and Graphic terminal remote up to 200 meters (two TCONN bypass cards must be used from 50 to 200 meters).
- Touch panel installed in the electrical cabinet and User terminal remote up to 100 meters.



Graphic terminal



Touch panel



User terminal

## FACTORY OPTIONS AND ACCESSORIES

- Control without terminal (for units with shared terminal in a pLAN local network).

Note: Multiple units can share a terminal if they are integrated into a local pLAN network (for up to 15 units). This is not possible in units configured as "Backup", since the two units must be fully autonomous in their operation.

- By default, the electronic control is configured for a stand-alone unit, but it is also possible to include it in an shared network (SHRD) as Master, Slave or Backup. The maximum number of units that can be integrated into an "Master/Slave" shared network is 15, and in the case of "Backup" it is 2 units.

Important: to use any of the following functionalities it is necessary to configure in the "Selection Program" a unit as Master and all other units as Slaves (including the Backup unit).

The specific functionality will be configured on site (according to the "50FC" regulation manual).

The shared network (SHRD) allows to have the following functionalities depending on the parametrized configuration:

### - Master/Slave:

It allows to share some of the probes installed in the Master unit: ambient temperature or ambient temperature + humidity, outdoor temperature, outdoor humidity and CO<sub>2</sub> air quality.

### - Extended Master/Slave:

It includes "Master/Slave" functionalities and the master unit provides ambient temperature setpoints to the other units.

### - Master/Slave with the same operating mode:

It includes the "Extended Master/Slave" functionalities and the master unit also provides the status (Cooling-Heating - Ventilation) to the other units.

### - Backup in case of alarm:

One unit is configured as a Backup unit, for activation in case of malfunction of the other unit.

### - Extended Backup:

It includes the "Backup in case of alarm" functionalities and also, the control manages the automatic switching between the two units weekly, to compensate the operation times of both units.

Note: In the case of installations with Backup units, it is not possible to share the probes, since both units must be fully autonomous in their operation. If both units are connected to the same supply duct network, it is imperative that the installation consists of non-return dampers (installer responsibility).

- The control board includes two communication ports that allow connection with a centralized technical management system: a BMS port for Modbus RTU protocol and an Ethernet port for Modbus TCP/IP protocol.

A communication card (optional) can also be connected to the board for the following protocols:

- TCP/IP, Modbus TCP/IP, SNMP V1-2-3, FTP, HTTP (E: Ethernet PCoWeb card),
- Ethernet BACnet™ (B: Ethernet BACnet™ card),
- BACnet™ MSTP (C: RS485 BACnet™ card),
- Konnex (K: RS485 Konnex card),
- Modbus RTU (M: RS485 Modbus card).

Note: refer to the electronic control manual for more complete information.

## Local supervision solutions

Different solutions of supervision are available bases on the dimensions of the installation:

### - pCO Web:

It is a solution for the management and supervision of a single unit through an HTML page included in the Ethernet pCO Web card.

### - BOSS:

This is the solution for the management and supervision of air-conditioning installations with up to 300 units. Communication is via the Modbus TCP/IP port integrated into the µPC3 control board.

Its main advantages are:

- Integrated WIFI Hotspot for direct access without any extra infrastructure.
- Smartphone compatibility.
- Secure supervisor control from remote through a simple browser.

It offers advanced monitoring and maintenance functions and allows zones and groups to be created to simplify the management of the installation.

It also allows energy meters to be integrated to monitor the installation electricity consumption.

BOSS is available in two versions:

- CPU device.
- CPU device, monitor, mouse and keyboard.

### - BOSS mini:

This is the solution for the management and supervision of air-conditioning installations with up to 10 units with 50 variables per unit or 50 units with 10 variables maximum per unit, but with the same features as BOSS.

BOSS mini is available in two versions:

- CPU device.
- CPU device, monitor, mouse and keyboard.

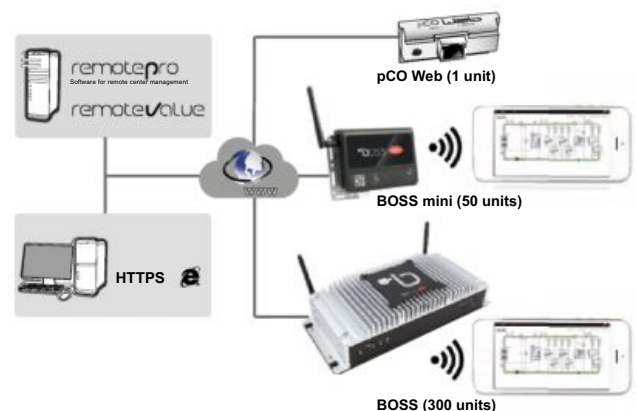

These systems are used to manage the installation remotely. All the information on the system can be accessed via a simple Internet connection.

The online interface, the same one used by the local user, enables monitoring and complete configuration of the installation: from the office or anywhere else the user happens to be.

## FACTORY OPTIONS AND ACCESSORIES

### Remote supervision solution

**ABOUND HVAC Performance** is a remote supervision solution dedicated to monitoring and controlling several CARRIER machines in real time.

ABOUND HVAC Performance will send data in real time to the supervision website. The machine operating data can be accessed from any PC, smartphone or tablet. Any event can be configured to trigger a mail alert.

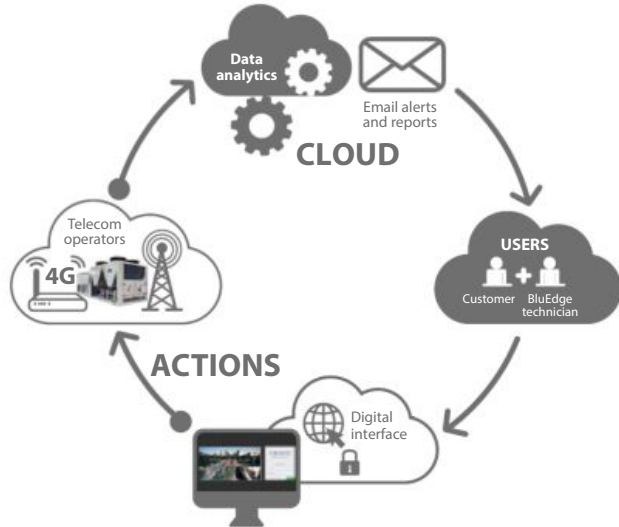

There are 3 fan options depending on the airflow: low, nominal and high.

- Return plug-fan. There are 3 fan options depending on the available pressure:

- N: Nominal available pressure (Polypropylene).
- M: Nominal available pressure (Aluminium).
- S: High available pressure (Aluminium).

Important: the "Selection Software" will choose the fan with lower consumption for the available pressure required.

### Pre-assembly roof curbs

- The units can rest on standardised pre-assembly roof curbs with adjustable height, built in galvanised steel panelling with polyester paint and thermal insulation.

The levelling system uses angle pieces that allow adjustments in the X and Y axes.



- Adaptation roof curbs ready for direct replacement on site of units from different manufacturers (**upon request**).

### Miscellaneous item 1

- Management of an humidifier with on-off or proportional control.
- Electrical energy meter for monitoring of the power consumption of the installation.
- Cooling capacity and electrical energy meter. In addition to the energy meter, the unit incorporates mixing and supply enthalpic sensors with RS485 communication that enable cooling and heating capacities to be calculated.

### Miscellaneous item 2

- Varnish protection for the components on the electrical cabinet: control board, cards and terminals.

### Return fan

- Centrifugal return fan, coupled by pulleys and belts. Electric motor with tensioner, class F, IP55 and internal thermal protection. Turbine with an impeller of front-curved blades. Greased spherical bearings, with no maintenance required. Available in BB and BT assemblies.



## ADDITIONAL FACTORY OPTIONS UPON REQUEST

This chapter contains additional options available upon request, in addition to those already indicated on the previous chapter:

Description	Installation in factory	Installation on site	
Options of electronic control	Activation of the remote COOLING / HEATING operating mode	✓	
	General alarm signalling by relay	✓	
	Mechanical disconnection of stages	✓	
	Ventilation mode with 100% fresh air by digital input	✓	
	Control of supply and return dampers		✓
	Ventilation with differential air pressure sensor		✓
Constant supply pressure		✓	
Adjustable pre-assembly roof curbs with higher height		✓	

### General alarm signalling

"50FC" control allows the management of a relay for remote alarm signalling.

The output for general alarm signal is not compatible with the following options: hot water coil, heat recovery coil, rotary heat exchanger and on/off signal for external humidifier. In this case, upon request, it would be possible to have a general alarm output in an input/output expansion module.

### Mechanical disconnection of stages

This option allows the mechanical disconnection of stages of compressor and/or electrical heaters using digital inputs. This is especially useful in the following cases:

- To reduce electricity consumption in certain time slots.
- When electricity consumption is limited.

### Ventilation mode with 100% fresh air by digital input

"50FC" control allows to manage a ventilation mode with 100% fresh air through the graphic terminal or by BMS supervision, but on certain occasions it may be interesting to activate this mode through a digital input. This option is especially useful when rapid air renewal is needed, for example in cinema rooms.

### Control of supply and return dampers

This function allows the management of external drive and return dampers located in the ducts, so that the closure of the ducts can be controlled after the unit is stopped. This option can also be useful in installations with Back-up units.

### Ventilation with differential air pressure sensor

In installations with this differential pressure sensor, the percentage of air renewal is adjusted according to the pressure in the room. This option allows dynamic control of the damper opening by measuring the pressure differential between inside and outside.

### Constant supply pressure

The 50FF/FC range provides the greatest choice in terms of multi-zone management. This new option of "Constant supply pressure" is added to the option "Air flow zoning up to 4 zones".

This function allows to control the air flow to maintain constant pressure in the supply duct, with the setpoint value set by parameter.

The following table provides the comparison of the two solutions to facilitate the correct selection according to the customer needs:

Characteristics	Zoning up to 4 zones	Constant supply pressure
Number of zones	up to 4	unlimited
Type of fan	plug-fan	plug-fan
Components included	4 zone terminals and a control box	differential pressure sensor (range 0 - 1000 Pa)
Dampers and servos per zone	not supplied	not supplied
Control signal for dampers / servos	supplied	not supplied (external control required)
Control of the damper for each zone	yes, control carried out by the electronic control	no (at customer level)
Terminal in each zone	yes	No or just one for the main zone (see "Configurations")
Minimum air flow	35%	35% or 10% in ventilation mode (operating only the fans). There is an associated alarm in case of lower airflow. It is necessary to set the minimum damper opening per zone or provide remote stop control in case all dampers are closed
Capacity control	Based on the ambient temperature conditions of each zone terminal (by default) or the return temperature (optional)	<ul style="list-style-type: none"> <li>• Based on the return conditions (by default)</li> <li>• Based on the environment conditions (configurable), in case of a main zone (see "Configurations")</li> </ul>

Configurations	
Capacity control based on the return conditions (by default)	Capacity control based on the environment conditions (configurable)
Several zones	Several zones (one main zone)
Same comfort priority by zone	One main zone. Comfort of all zones depends on the demand of the main zone

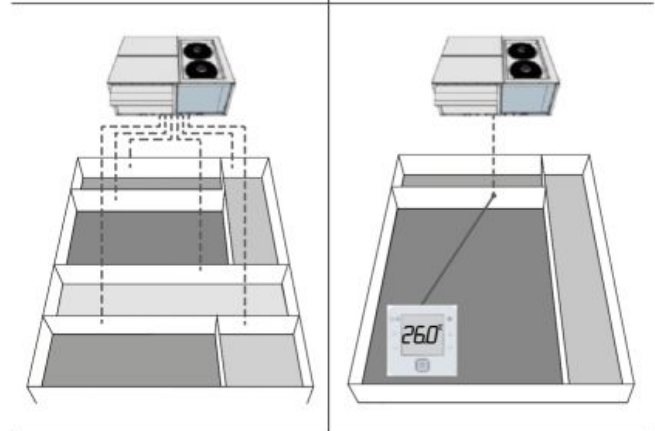

Note: For variable management of fresh air it is necessary to select the optional return air quality probe (CO<sub>2</sub>) (instead of the ambient probe).

There is only one case in which the ambient air quality probe can be used: with constant supply pressure and capacity based on the environmental conditions of the main zone.





## WEIGHT OVERVIEW

### Weight overview of the various assemblies (kg)

50FF/FC		100	110	120	130	145	160	170	180	200	220	250	280	
Standard insulation	B1 assembly	1430	1450	1470	1640	1680	1690	1700	2265	2370	2475	2795	2860	
	B2 assembly	1505	1525	1545	1713	1753	1763	1773	2402	2477	2582	2946	3011	
	BP assembly	1713	1733	1753	1982	2022	2032	2042	2797	2872	2977	3291	3356	
	BA assembly	1824	1844	1864	2132	2172	2182	2192	2987	3062	3167	3491	3556	
	BT assembly	1809	1829	1849	2072	2082	2092	2102	2907	2982	3087	3341	3406	
	BB assembly	1919	1939	1959	2222	2232	2242	2252	3057	3132	3237	3541	3606	
	BW assembly	Machine	1677	1697	1717	1868	1908	1918	1928	2806	2881	2986	3234	3299
		Wheel module (smaller diam.)	560	560	560	650	650	650	650	685	685	685	705	705
		Total weight	2237	2257	2277	2518	2558	2568	2578	3491	3566	3671	3939	4004
M0 insulation	B1 assembly	1550	1570	1590	1735	1775	1785	1795	2415	2520	2625	2995	3060	
	B2 assembly	1630	1650	1670	1808	1848	1858	1868	2552	2627	2732	3146	3211	
	BP assembly	1834	1854	1874	2097	2137	2147	2157	2992	3067	3172	3516	3581	
	BA assembly	1949	1969	1989	2267	2307	2317	2327	3182	3257	3362	3716	3781	
	BT assembly	1919	1939	1959	2197	2237	2247	2257	3102	3177	3282	3566	3631	
	BB assembly	2049	2069	2089	2367	2407	2417	2427	3252	3327	3432	3766	3831	
	BW assembly	Machine	1787	1807	1827	2113	2153	2163	2173	3001	3076	3181	3459	3524
		Wheel module (smaller diam.)	590	590	590	685	685	685	685	725	725	725	745	745
		Total weight	2377	2397	2417	2798	2838	2848	2858	3726	3801	3906	4204	4269

### Weight supplement from the main options (kg)

50FF/FC		100	110	120	130	145	160	170	180	200	220	250	280
Larger diameter wheel (recovery module)		10	10	10	20	20	20	20	10	10	10	10	10
Outer security base (only with pre-assembly roof curb)		--	--	--	--	--	--	--	67	67	67	95	95
Pre-assembly roof curb (without gas burner)		363	363	363	386	386	386	386	470	470	470	552	552
Pre-assembly roof curb (with gas burner)	BAM (Nominal)	882	882	882	979	979	979	979	1194	1194	1194	1323	1323
	BAS (High)	936	936	936	1026	1026	1026	1026	1238	1238	1238	1366	1366
Electrical heaters	RAF (Low)	29	29	29	34	34	34	34	40	40	40	45	45
	RAM (Nominal)	32	32	32	41	41	41	41	57	57	57	58	58
	RAS (High)	39	39	39	55	55	55	55	64	64	64	73	73
Hot water coil (HWC)	Empty	94	94	94	102	102	102	102	113	113	113	128	128
	Service	143	143	143	155	155	155	155	181	181	181	201	201
Heat recovery coil (HRC)	Empty	77	77	77	84	84	84	84	90	90	90	109	109
	Service	123	123	123	132	132	132	132	153	153	153	181	181
Supply fan	Low pressure, aluminium (F)	-28	-28	-28	7	-25	-25	-25	-32	-32	-32	-21	-21
	Nominal pressure, aluminium (M)	7	7	7	41	9	9	9	11	11	11	14	14
	High pressure, aluminium (S)	65	65	65	65	33	86	86	108	108	108	129	129
Droplet eliminator	Indoor coil	67	67	67	78	78	78	78	84	84	84	97	97
	Fresh air intake: B2, BW assemblies	23	23	23	26	26	26	26	29	29	29	33	33
	Fresh air intake: BP, BA, BT, BB assemblies	18	18	18	21	21	21	21	23	23	23	26	26
Outdoor coil protection grid		40	40	40	50	50	50	50	17	17	17	20	20
Filters	G4 low pressure drop	2	2	2	3	3	3	3	4	4	4	5	5
	G4 + F7	16	16	16	19	19	19	19	22	22	22	24	24
	G4 low pressure drop + F7	17	17	17	30	30	30	30	23	23	23	26	26
	M6 + F7	25	25	25	29	29	29	29	34	34	34	35	35
	F7 + F9	26	26	26	30	30	30	30	35	35	35	39	39
Centrifugal return fan (BT and BB assemblies)	Low airflow	45	33	41	78	50	46	29	58	62	3	58	69
	Nominal airflow	102	102	102	61	37	47	48	132	126	83	83	167
	High airflow	102	84	97	70	48	48	111	132	--	--	168	188
Return plug-fan (BP, BA, BT, BB and BW assemblies)	Nominal pressure, aluminium (M)	4	4	4	43	10	6	6	9	0	0	0	0
	High pressure, aluminium (S)	43	43	43	97	65	65	65	65	59	0	78	78

## RECOMMENDED SERVICE CLEARANCE

### 50FF/FC 100 to 170: B1 and B2 assemblies

50FF/FC	Overall dimension (mm)			Service clearance (mm)			
	Length	Width	Height	A	B	C	D
100 to 120	3.820	2.257	2.293	2.200	1.000	1.200	1.000
130 to 170	4.224	2.257	2.340	2.400	1.000	1.200	1.000

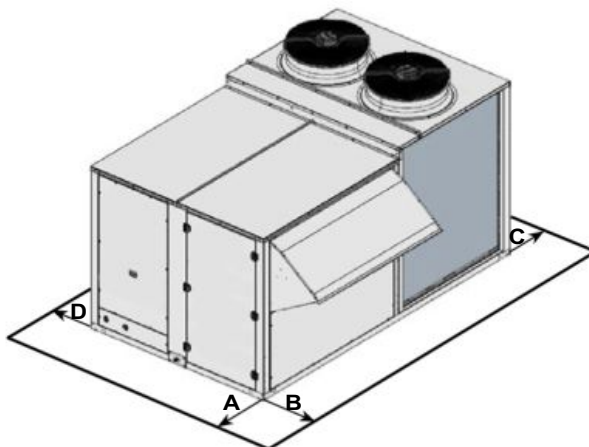

### 50FF/FC 100 to 170: BP and BA assemblies

50FF/FC	Overall dimension (mm)			Service clearance (mm)			
	Length	Width	Height	A	B	C	D
100 to 120	3.820	2.257	2.555	2.200	1.000	1.200	1.000
130 to 170	4.224	2.257	2.555	2.400	1.000	1.200	1.000

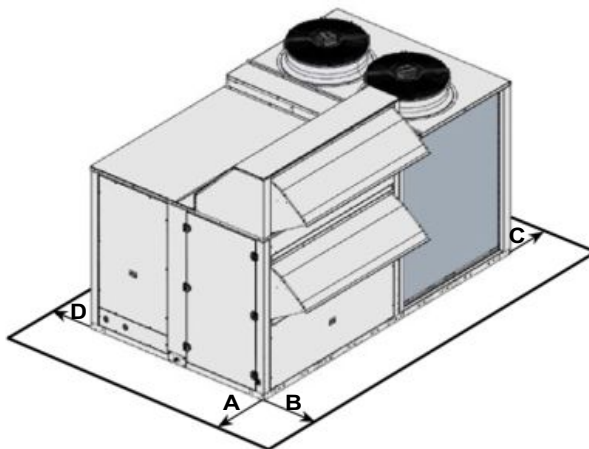

### 50FF/FC 100 to 170: BT and BB assemblies

50FF/FC	Overall dimension (mm)			Service clearance (mm)			
	Length	Width	Height	A	B	C	D
100 to 120	3.825	2.268	2.555	2.200	1.000	1.200	1.000
130 to 170	4.229	2.268	2.555	2.400	1.000	1.200	1.000

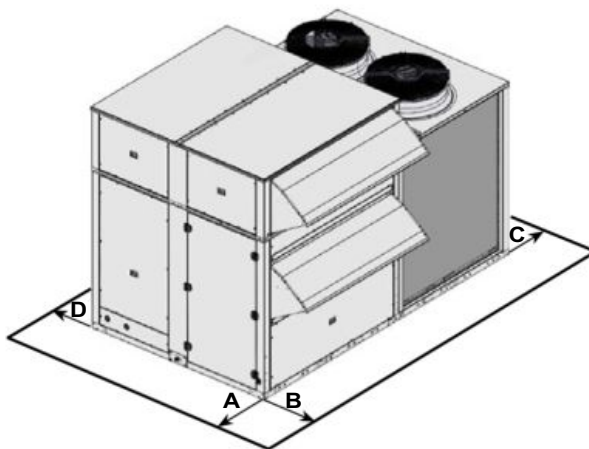

### 50FF/FC 100 to 170: BW assembly

50FF/FC	Overall dimension (mm)			Service clearance (mm)			
	Length	Width	Height	A	B	C	D
100 to 120	3.820	3.112	2.255	2.200	1.000	1.200	1.000
130 to 170	4.224	3.112	2.555	2.400	1.000	1.200	1.000

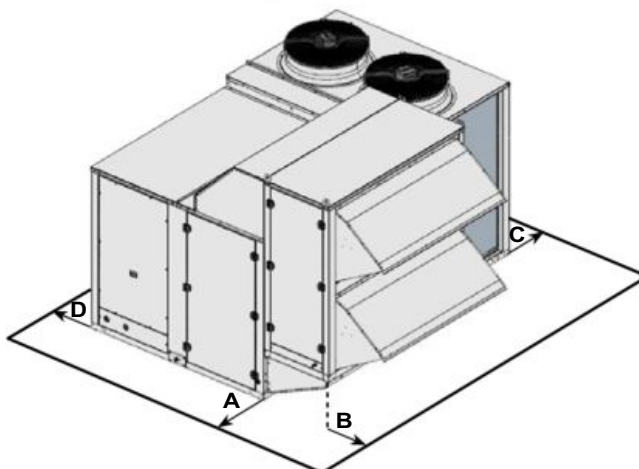

**NOTE:**

- Unit not designed to have overhead obstruction.

## RECOMMENDED SERVICE CLEARANCE

### 50FF/FC 180 to 280: B1 and B2 assemblies

50FF/FC	Overall dimension (mm)			Service clearance (mm)			
	Length	Width	Height	A	B	C	D
180 to 220	5.300	2.257	2.421	2.600	2.500	1.200	1.000
250 to 280	6.350	2.257	2.494	3.000	2.500	1.200	1.000

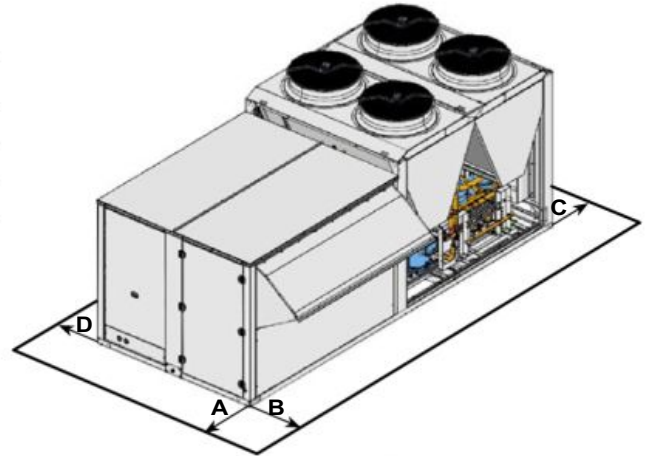

### 50FF/FC 180 to 280: BP and BA assemblies

50FF/FC	Overall dimension (mm)			Service clearance (mm)			
	Length	Width	Height	A	B	C	D
180 to 220	5.300	2.257	2.555	2.600	2.500	1.200	1.000
250 to 280	6.350	2.257	2.555	3.000	2.500	1.200	1.000

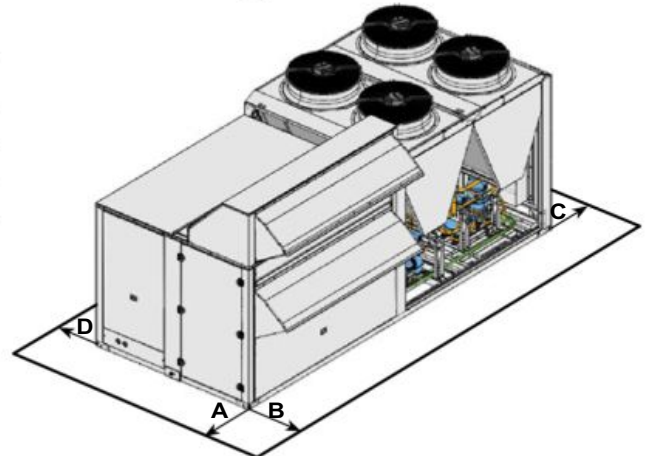

### 50FF/FC 180 to 280: BT and BB assemblies

50FF/FC	Overall dimension (mm)			Service clearance (mm)			
	Length	Width	Height	A	B	C	D
180 to 220	5.306	2.268	2.555	2.600	2.500	1.200	1.000
250 to 280	6.356	2.268	2.555	3.000	2.500	1.200	1.000

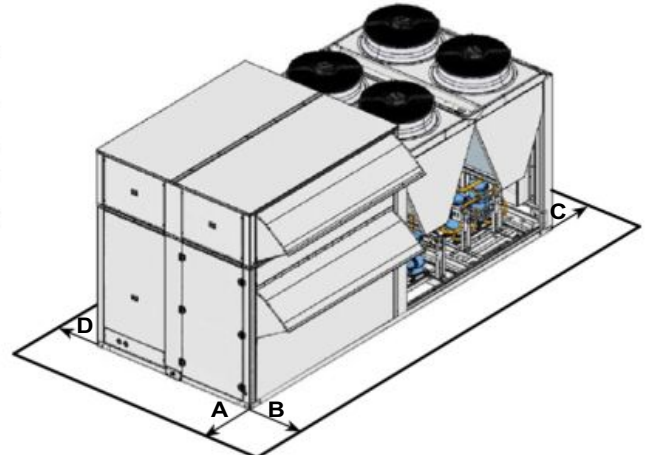

### 50FF/FC 180 to 280: BW assembly

50FF/FC	Overall dimension (mm)			Service clearance (mm)			
	Length	Width	Height	A	B	C	D
180 to 220	5.300	3.112	2.555	2.600	1.700	1.200	1.000
250 to 280	6.350	3.112	2.555	3.000	2.500	1.200	1.000

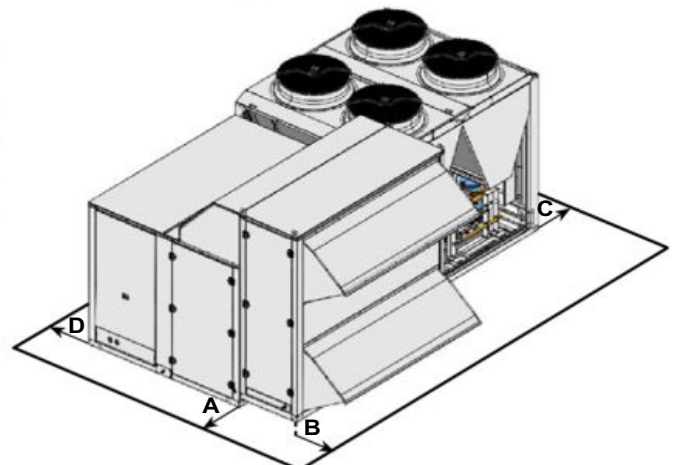

**NOTE:**

- Unit not designed to have overhead obstruction.

**NEW**

## VERTICAL AUTONOMOUS HEAT PUMPS



Package and split versions  
 High adaptability  
 Flexibility of configuration  
 Scroll compressors in tandem  
 Plug-fans with EC HEE motor

# 50NC 022 - 118

Nominal cooling capacity 34,3 - 81,5 kW  
 Nominal heating capacity 34,4 - 83,4 kW



**50NC** reversible heat pumps are vertical air-to-air units consisting of two modules (indoor and outdoor), which can be supplied in Package or Split version.

Ten models are available:

- 1 circuit and 2 compressors: models 022, 028, 038 and 042.
- 2 circuits and 4 compressors: models 058, 064, 074, 086, 106 and 118.

They are units designed for indoor installation with their two modules attached to a network of air distribution ducts. Its cabinet design has a great adaptability, and allows the cooling and heating of premises where the installation on the roof is too complex or it is necessary to respect the architecture of the building.

A vast number of options makes it possible to meet many operating requirements.

These units are equipped with hermetic scroll-type compressors in tandem design, as well as electronic plug-fans for the outdoor and indoor modules, achieving a high seasonal performance.

■ **Compliance:**

- Machinery Directive 2006/42/EC (MD)
- Electromagnetic Compatibility Directive 2014/30/EU (EMC)
- Pressure Equipment Directive 2014/68/EU (Category 1) (PED)
- Eco-design Directive 2009/125/EC (Eco-design)
- Regulation (EU) 2016/2281 SEER/SEPR HT
- Harmonised Standard: EN 378-2:2016 (Refrigerating systems and heat pumps
  - Safety and environmental requirements. Part 2: Design, construction, testing, marking and documentation)



## CUSTOMER BENEFITS

### Outstanding performance

CARRIER concentrates its efforts on making its units more efficient and more environmentally responsible. The **50NC** range goes beyond 2021 Ecodesign requirements. Up to 30% savings.



### Energy savings

We develop energy-efficient solutions that provide substantial savings. The **50NC** range has been designed to reduce energy consumption with advanced features:

- Variable ventilation with electronic plug-fans. In tertiary sector installation, a high percentage of the annual air conditioning energy consumption comes from the use of fans for transporting air. Using fans which are more efficient has a direct impact on reducing consumption.
- Low pressure drop filters.
- Free-cooling allows make the best use use of outdoor air conditions when these are more favourable than the return air conditions. This allows the cooling capacity to be reduced. Up to 30% energy savings due to the cooling capacity reduction.

### Advanced system control

“50FC” control is dedicated to optimizing the performance at part load conditions, increases the seasonal efficiency and operational limits in all seasons.

### Adaptability

- **Package** and **Split** versions fit perfectly all types of buildings. Ideal for urban environments where installation on the roof is too complex.

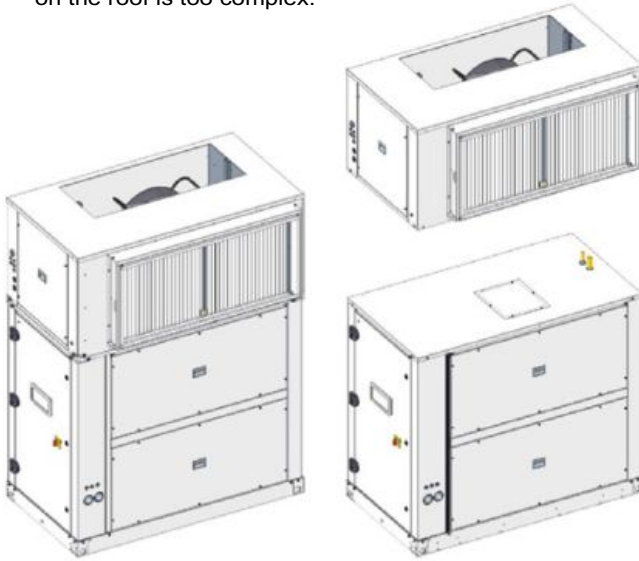

Package version

Split version

- Reduced height (< 2,200 mm) in the Package version.
- Long distance refrigerant connections between the condensing unit and the air treatment unit in the Split version.

### Configuration flexibility

The **50NC** range offers a wide range of options to address the most specific requirements to be the **perfect solution for every application** with maximum comfort, energy efficiency and indoor air quality in mind.

### Healthier indoor environment

The **50NC** range offers a wide range of technological features dedicated to improve and maintain the highest level of indoor air quality:

- Air filtration. It is an efficient way to reduce particles that can harm our health. Filter fouling detector determines when the filter needs to be replaced.
- CO<sub>2</sub> sensors that allow ventilation based on the comparison of CO<sub>2</sub> levels between indoor and outdoor sources.
- Air flow control. It ensures proper comfort in spaces: temperature, humidity, air flow and overpressure.
- Ventilation of spaces with outdoor air. It reduces indoor pollutants to maintain indoor air quality.

Discover more about Carrier’s approach to Healthy Buildings on:

<https://www.corporate.carrier.com/healthybuildings/>

### Acoustic comfort

We guarantee **low noise level** during operation to meet the highest requirements thanks to the design optimization and the use of latest technology for fans and compressors.

### Intelligence and connectivity

The advanced “50FC” intelligent control system displays operating parameters in real-time, making it intuitive and particularly user-friendly. The 50NC range is also characterized by a brand new smart energy monitoring function that provides users with smart data such as electrical energy consumption in real-time, supplied cooling and heating energy as well as instantaneous and average seasonal energy efficiency values.

It also guarantees easy installation and integration into the building management system.

- Plug & play solution fully programmed and set up from the factory.
- Wide supervision offer from 1 to 300 units.
- Communication with all building management system protocols through Modbus, BACnet, Konnex, TCP/IP, SNMP V1-2-3, FTP and HTTP.
- Remote supervision solution ABOUND HVAC Performance. It is an advanced monitoring solution that enables customers for all applications to track and monitor their CARRIER equipment.

### Superior reliability

The **50NC** range has been designed to ensure robustness throughout the lifecycle of the units. The high-reliability of the units is the result of high-quality material and components combined with the highest quality standards in terms of manufacturing and laboratory testing.



## NOMENCLATURE OF THE MODEL NUMBER

A	B	C	D	E	F	G	H	I	J	K	L	M	N	O	P	Q	R	S	T	U	V	W	X	Y	Z
50NC	022	C	00	A	4	A	C0	AA	000	0	N	A	N	0	000	0000	0	0	0000	00	000	00	0	000	00

### A: Unit range

- 50NC: air/air heat pump

### B: Unit model

- 1 circuit: 022 / 028 / 038 / 042
- 2 circuits: 058 / 064 / 074 / 086 / 106 / 118

### C: Unit type

- C: Package
- P: Split

### D: Air direction: Indoor circuit - Outdoor circuit

- 00: Lateral supply - Lateral supply
- 01: Lateral supply - Upper supply
- 10: Upper supply - Lateral supply
- 11: Upper supply - Upper supply

### E: Version of the series

### F: Electrical power

- 3: 400 V / 3 ph + N / 50 Hz
- 4: 400 V / 3 ph / 50 Hz

### G: Type of refrigerant

- U: R410A

### H: Assembly

- C0: Standard assembly
- CS: Assembly with 2 dampers mixing box

### I: Coil coating : Indoor circuit - Outdoor circuit

- AA: Aluminium - Aluminium
- AC: Aluminium - Inera®
- CC: Inera® - Inera®

### J: Auxiliary heating

- 000: Without auxiliary heating
- E0x: Electrical heaters, 3 power outputs:  
Low (L) / Nominal (N) / High (H)

### K: Protection for low outdoor temperature

- 0: Without protection

### L: Available pressure of the indoor fan

- N: Nominal available pressure
- H: High available pressure

### M: Air filtration + stop-drop

- A: G4
- B: G4+ stop-drop
- C: G4 low pressure drop
- D: G4 low pressure drop + stop-drop
- G: G4 + F7
- H: G4 + F7 + stop-drop
- K: G4 low pressure drop + F7
- L: G4 low pressure drop + F7 + stop-drop

### N: Available pressure of the outdoor fan

- N: Nominal available pressure

### O: Insulation

- 0: Standard insulation

### P: Indoor circuit configuration

- 000 — Without options
  - Unused
  - A: Compressor insulation
  - A: Clogged filters pressostat

### Q: Outdoor circuit configuration

- 0000 — Without options
  - A: Service valves and refrigerant precharge
  - 0: Unused
  - A: Antivibration mounts
  - 1: Long distance

### R: Heating extra

- 0: Without extra heating
- C: Heat recovery coil

### S: Special applications

- 0: Without special applications
- Z: Air zoning
- I: Low return temperature application
- K: Low return temperature application + Air zoning
- P: Constant supply pressure
- R: Constant supply pressure + Low return temperature application

### T: Sensors

- 0000 — Without options
  - H: Smoke detector sensor
  - A: Air quality sensor for environment
  - C: Air quality sensor duct-mounted
  - D: Double quality sensor: environment + environment
  - E: Double quality sensor: environment + outdoor
  - F: Double quality sensor: duct-mounted + outdoor
  - P: Air quality sensor on the SHRD network
    - 1: 1 sensor RS485
    - 2: 2 sensors RS485
    - 3: 3 sensors RS485
    - 4: 4 sensors RS485
    - 5: 1 sensor NTC
  - T: Ambient temperature sensor
  - H: Ambient temperature + humidity sensor
  - P: Ambient sensor on the SHRD network

### U: Free-cooling / Outdoor humidity

- 00 — Without free-cooling + without sensor
  - 1: Outdoor humidity sensor on the unit
  - 2: Outdoor humidity sensor on SHRD network
  - T: Thermal free-cooling
  - M: Thermoenthalpic free-cooling
  - E: Enthalpic free-cooling

### V: Terminal + Unit communication

- 000 — Without terminal + stand-alone + without card
  - B: Communication card Ethernet BACnet™
  - C: Communication card RS485 BACnet™
  - K: Communication card RS485 Konnex
  - 0: Free-standing unit
    - 1: Master unit
    - 2: Slave unit
  - P: Graphic terminal in electrical cabinet
  - T: User terminal in electrical cabinet
  - R: Graphic terminal in electrical cabinet + User terminal remote up to 100 m
  - S: User terminal in electrical cabinet + Graphic terminal remote up to 200 m
  - N: Graphic terminal in electrical cabinet + Graphic terminal remote up to 200 m

### W: Miscellaneous item 1

- 00 — Without options
  - E: Energy meter
  - M: Energy meter and calculation of cooling and heating capacities
  - 1: Tropicalization

### X: External mixing box

- 0: Without external mixing box
- 1: External mixing box with 3 dampers
- 2: External mixing box with 2 dampers

### Y: Unused

- 000: Unused

### Z: Special manufacturing

- 00: Without special manufacturing

## MAIN FEATURES



## UNIT COMPONENTS

### Outdoor module

#### Casing

- Casing made of galvanised steel metal. Most parts protected with polyester paint finished in white color, RAL 7035. Self-supporting frame.
- Transport skids and guides to accommodate the forklift truck.

#### Outdoor air circuit

- Coil(s) with copper pipes and aluminium fins.
- EC electronic supply plug-fan(s) with variable control speed and flow rate controller.  
In tertiary sector installation, a high percentage of the annual air conditioning energy consumption comes from the use of fans for transporting air. Using fans which are more efficient has a direct impact on reducing consumption.
- Condensate drain pan.

#### Refrigerant circuit

- Hermetic scroll-type compressors in tandem design that improves the management of stages and the part load efficiencies, assembled over antivibration mounts. Relay for phase-sequence monitoring and phase loss protection.
- Crankcase heater.
- Thermostatic expansion valve(s) with external equalisation.
- Four-way cycle reversing valve(s).
- Acid-resistant filter(s) dryer.

- Suction accumulator(s) (Split version).
- Refrigerant connections for welding when the unit is supplied in Split version. Optionally, the module can be supplied with service valves and refrigerant precharge.

#### Electrical cabinet

- Complete and fully wired electrical cabinet. Insulated access door to prevent condensation. Protection IP55.
- Numeration of wired and identification of components in the electrical cabinet. It permits easy tracing and diagnostics.
- Hinges + quarter-turn latches on the removable access door.
- Electrical power supply with neutral.
- Main ground connection.
- Compressor(s) and fan(s) motor contacts.

#### Protections

- High pressure switch(es).
- High and low pressure transducers.
- Refrigerant leak control (by low-pressure alarm).
- Compressor discharge temperature control.
- Main door switch.
- Protection for power lines of compressors with manual motor starters and power lines of fan motors with magnetothermic switches. These devices provide protection against overload, short circuit, phase failure and undervoltage.
- Automatic switch in the control circuit.

## UNIT COMPONENTS

### Indoor module

#### Casing

- Casing made of galvanised steel metal. Most parts protected with polyester paint finished in white colour, RAL 7035. Self-supporting frame.
- Support feet for transport with Split version.

#### Indoor air circuit

- Coil(s) with copper pipes and aluminium fins.
- EC electronic supply plug-fan(s) with variable control speed and flow rate controller.  
The fans are factory configured with nominal air flow. Consult for any special configuration.
- Reusable G4 gravimetric filters, mounted on a frame attached to the air return.
- Condensate drain pan.

#### Refrigerant circuit

- Thermostatic expansion valve(s) with external equalisation and retainer.
- Refrigerant connections for welding when the unit is supplied in Split version.

#### Electrical cabinet

- Complete and fully wired electrical cabinet. Insulated access door to prevent condensation. Protection IP55.  
This cabinet is foldable to allow access to the interior of the module.
- Fan(s) motor contact(s).

### “50FC” electronic control

The “50FC” control consist of a control board, sensors, a Graphic terminal and a User terminal (optional).

The control board includes a RS485 field-bus to manage additional components such as: expansion modules and boards, plug-fans, probes of temperature or relative humidity of the ambient air, energy meters, etc.

This board also integrates two communication ports that allow connection with a centralized technical management system such as BOSS and BOSS mini. A BMS port for Modbus RTU protocol and an Ethernet port for Modbus TCP/IP protocol.

A communication card (optional) can also be connected to the control board for the following protocols: Ethernet BACnet™, MSTP BACnet™ and Konnex.

“50FC” control enables unit integration with our local supervision solutions: pCO Web (1 unit), BOSS mini (50 units) and BOSS (300 units), as well as with the remote solution: ABOUND HVAC Performance.

With this control, it is also possible to connect to a shared network (SHRD) for a maximum of 15 units, with one unit configured as “Master” and the other units as “Slaves”. This network allows the exchange of data and information between the units, and depending on the conditions of the installation, it can share the reading of some probes installed on the unit configured as “Master”, temperature setpoints, and operating mode. It is also possible to configure one unit as a “Backup”, for activation in case of malfunction of the other unit.

- The main functions of regulation are:

- Selection of setpoint and operating mode: HEATING / COOLING / AUTO / VENTILATION.
- Continuous control of the operating parameters.
- Display of the values measured by the sensors.
- Compressors time delays.
- Defrosting management.
- Control of the supply air temperature.
- All-seasons operation via the condensation and evaporation pressure control.
- The management of the unit in cooling mode is based on the principle of a high floating pressure. The condensation pressure setpoint is continually calculated depending on the outdoor temperature. This pressure is regulated by adjusting the air flow on the outdoor fans.
- Setpoint compensation based on the outdoor temperature.
- Hourly and weekly schedule.
- Fire protection.
- Diagnosis of faults and general alarm.
- Management of all the optional components available for the unit: dampers and mixing boxes, auxiliary heating, air quality sensors, air zoning...

### User interfaces

#### Graphic terminal

This terminal, fitted as standard on the electrical cabinet, is very easy to use. It provides detailed explanations of control in easy to understand English. No decoding is required.



Only 6, large, easy-to-use buttons are required to maneuver through the entire menus.

- This terminal is used to:

- Carry out initial programming of the unit.
- Modify operating parameters.
- Switch the unit ON / OFF.
- Select the operating mode and adjust the setpoints.
- Display the variables controlled and sensor values measured.
- Display the current alarms and their historical record.

Note: Multiple units can share a single terminal, if they are integrated into a pLAN local network (for up to 15 units).

#### User terminal (optional)

This terminal can be installed on the electrical cabinet, instead of the graphic terminal. In this case, the remote connection of the graphic terminal is possible.



- This terminal is used to:

- Switch the unit ON / OFF.
- Select the operating mode and adjust the setpoints.
- Display the installation's temperatures and humidity, outdoor temperature, supply air temperature, CO<sub>2</sub> sensor and opening of the outdoor damper.
- Display alarms codes.

## FACTORY OPTIONS AND ACCESSORIES

### Air direction

(Indoor circuit supply - Outdoor circuit supply)

#### Package version (C)

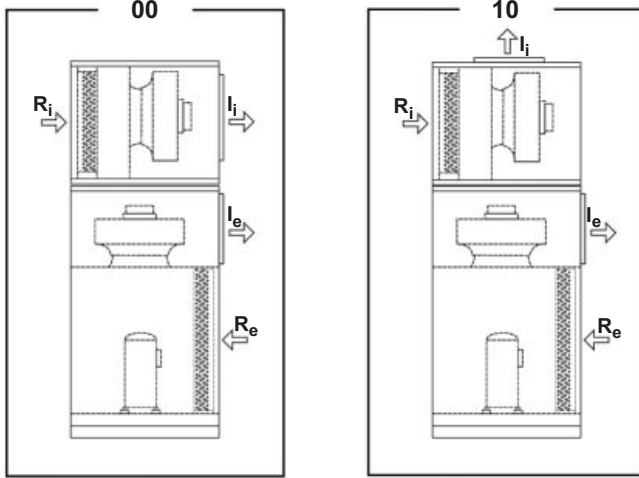

#### Split version (P)

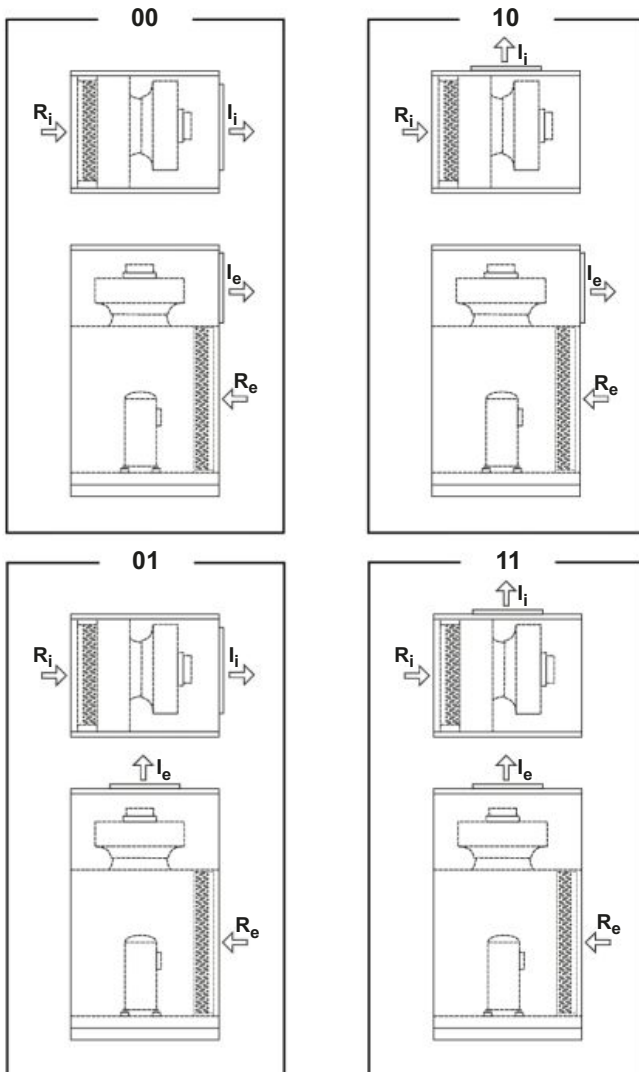

I<sub>i</sub>: Indoor circuit supply  
R<sub>i</sub>: Indoor circuit return

I<sub>e</sub>: Outdoor circuit supply  
R<sub>e</sub>: Outdoor circuit return

### Electrical power

These units can be supplied for the following power supply voltages:

- 400 V / 3 ph + N / 50 Hz (standard)
- 400 V / 3 ph / 50 Hz (optional)

### Assembly

- **CS assembly:** Mixing box with for air renewal and free-cooling managed by the electronic control of the unit. The box incorporates two interlocked dampers with a servomotor. Assembly and connection on site, at the return of the indoor module.

Available in Package and Split versions:

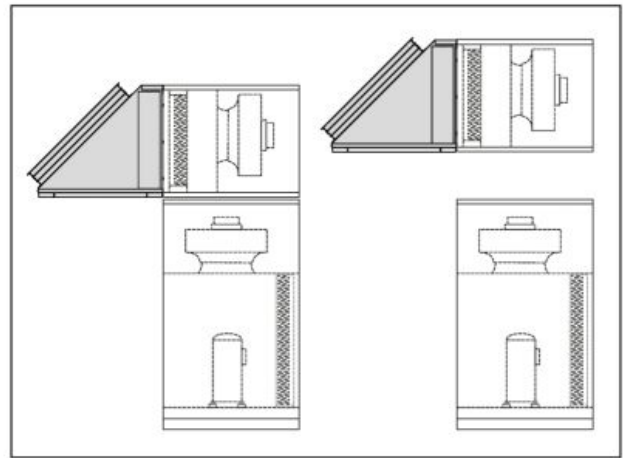

**Important:** In the Package version, both the connection of the mixing box and the construction of a structural support are the responsibility of the installer.

The following image shows the positions of the return air (R) and fresh air (N) dampers:



### Coils coating

- Coils with copper pipes and fins of an aluminium alloy **INERA®**. Level of corrosion protection: basic - medium. This treatment offers a resistance of more than 1000 hours (ASTM B117 NSST).

### Auxiliary heating

- **Auxiliary electrical heaters**, with two power stages and on/off control. Connection and assembly on site, at the outlet of the supply fan (indoor module).

Note: Electrical heaters with proportional control upon request.



## FACTORY OPTIONS AND ACCESSORIES

Up to 3 values of total power available for each model:

50NC series	022 to 028	038 to 042	058 to 086	106 to 118
E0L (Low)	9 kW	12 kW	18 kW	36 kW
E0N (Nominal)	12 kW	18 kW	24 kW	45 kW
E0H (High)	15 kW	24 kW	36 kW	54 kW



### Available pressure of the indoor fan

- By default, these units are fitted with plug-fans for a nominal available pressure (N). Optionally, aluminium fans with high available pressure (H) can be supplied.

Note: Aluminium fans are rated A2-s1, d0 (M0) and comply with regulations for public promises in France.

Important: the "Selection Software" will choose the supply fan with lower consumption for the available pressure required.

### Air filtration + stop-drop

Options to improve indoor air quality:

- The unit is shipped as standard with G4 filters, mounted in a frame attached to the return of the indoor module.

Note: This frame can be disassembled for space reasons during transport.



The frame can accommodate other combinations of filters:

- G4 gravimetric filters with low pressure drop (l.p.d.).
- G4 gravimetric filters standard type + F7 opacimetric filters.
- G4 gravimetric filters with low pressure drop (l.p.d.) + F7 opacimetric filters.

Classification of the filters according to the new **ISO 16890 Standard**:

- G4 → ISO Coarse 60%
- F7 → ISO ePM1 50%

- Stop-drop in the indoor air coil. Recommended in cases where a high moisture content in the air is foreseen or when the air flow is high.

### Indoor circuit configuration

- Acoustic insulating cover for compressor. The sound level reduction is approximately 2 dB(A).
- Differential pressure switch to detect clogged filters as safety protection.

### Outdoor circuit configuration

- Antivibration mounts made of rubber (silent-blocks). The Split version provides anti-vibration mounts for both modules. With mixing box (CS assembly) also its mounts are supplied.
- Service valves for refrigerant connections and refrigerant precharge for a maximum distance between the outdoor module and the indoor module of 7.5 meters (for Split version).
- Oil separator for long-distance (for Split version). The maximum equivalent length of the refrigerant line can be 50 meters when the outdoor module is above. For longer distances, up to 100 meters maximum, it is necessary to use an oil separator per refrigerant circuit.

### Extra heating

- Heat recovery coil (HRC). The coil function is to pre-heat the air that will pass through the main indoor coil. For this, it uses the temperature of an outdoor water installation. The filters + coil set is supplied disassembled for installation on site. The kit with the 3-way valve is also supplied separately from the coil for connection on site.



### Special applications

- Low return temperature application. Activation of the evaporation and condensation control of the indoor circuit as a function of the return temperature.



## FACTORY OPTIONS AND ACCESSORIES

### Multi-zone management solutions:

The "50FC" control provides the greatest choice in terms of multi-zone management with two different solutions:

- Air zoning up to 4 zones.
- Constant supply pressure.

The following table provides the comparison of the two solutions to facilitate the correct selection according to the customer needs:

Characteristics	Zoning up to 4 zones	Constant supply pressure
Number of zones	Up to 4	Unlimited
Type of fan	Plug-fan	Plug-fan
Components included	4 zone terminals and a control box	Differential pressure sensor (range 0 - 1000 Pa)
Dampers and servos per zone	Not supplied	Not supplied
Control signal for dampers / servos	Supplied	Not supplied (external control required)
Control of the damper for each zone	Yes, control carried out by the electronic control	No (at customer level)
Terminal in each zone	Yes	No or just one for the main zone (see "Configurations")
Minimum air flow	35%	35% or 10% in ventilation mode (operating only the fans) There is an associated alarm in case of lower airflow. It is necessary to set the minimum damper opening per zone or provide remote stop control in case all dampers are closed
Capacity control	Based on the ambient temperature conditions of each zone terminal (by default) or the return temperature (optional)	<ul style="list-style-type: none"> <li>• Based on the return conditions (by default)</li> <li>• Based on the environment conditions (configurable), in case of a main zone (see "Configurations")</li> </ul>

Note: In both cases, with the enthalpic or thermoenthalpic free cooling option (T+H control), it is necessary to add a return T+H probe in the unit selection.

### ■ Air flow zoning up to 4 zones

This option allows the management of the air flow of the unit to condition up to 4 different zones with a minimum air flow of 35% (all of them in same operating mode: heating or cooling).

"50FC" control gives the control signal to the dampers installed in each zone (dampers and servomotors for those dampers not supplied). The unit modifies the air flow and capacity depending on information coming from sensors in each zone and considering active zones in each moment.

The option includes 4 zone terminals (one for each zone) and a control board supplied in an independent box. The 4 terminals, the unit main board and also the servomotors that control dampers in each zone are connected on this board (dampers and servos not supplied).

The temperature information for each zone comes from a

temperature sensor integrated inside each zone terminal. It is not needed to install any extra ambient sensor.

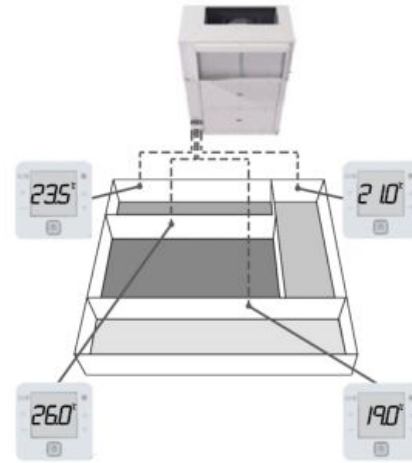

Note: If the unit additionally includes a CO<sub>2</sub> air quality probe, it must be a return probe and not an ambient probe.

### ■ Constant pressure supply

Using a differential pressure sensor, the air flow is controlled to maintain constant pressure in the supply duct.

This type of management eliminates the restriction of the number of zones, which facilitates a greater adaptation to the characteristics of the installation, although the customer must carry out the control of dampers in each zone.

It is also possible to choose between two different configurations:

Configurations	
Capacity control based on the return conditions (by default)	Capacity control based on the environment conditions (configurable)
Several zones	Several zones (one main zone)
Same comfort priority by zone	One main zone. Comfort of all zones depends on the demand of the main zone

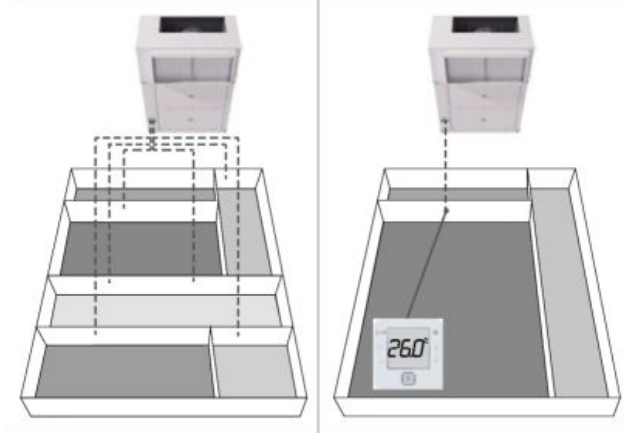

Note: For variable management of fresh air it is necessary to select the optional return air quality probe (CO<sub>2</sub>) (instead of the ambient probe). There is only one case in which the ambient air quality probe can be used: with constant supply pressure and capacity based on the environmental conditions of the main zone.

## FACTORY OPTIONS AND ACCESSORIES

### Sensors

- Sensor(s) of **ambient temperature**. There are 3 options:
  - One NTC sensor connected to the control board.  
Note: An ambient sensor with RS485 communication is required for installation at more than 30 meters.
  - One to four sensors with RS485 communication.
  - Sensor(s) installed on the master unit of the shared network (SHRD).

- One to four sensors of **ambient temperature + humidity**, with RS485 communication or installed on the master unit of the shared network (SHRD).

This sensor is compulsory in units with enthalpic or thermoenthalpic free-cooling (optional). In this case, the outdoor air humidity sensor is also added.

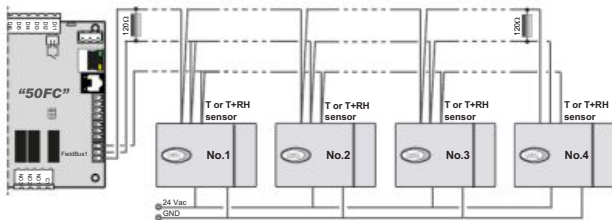

- **Smoke detecting** sensor. Smoke detecting station in accordance with the NF S 61-961 standard, 961, that uses a LED to indicate the installation status, and if the probe detects the presence of smoke in the installation, it stops the operation of the unit and gives the order to open or close the outdoor damper (configured by parameter).

To ensure compliance with the French regulations on Fire safety (ERP), it's possible to configure the opening of the fresh air damper and the exhaust air damper to 100% (return air damper closed).

- **Air quality** sensor to enable measuring CO<sub>2</sub>.

There are different options:

- Ambient air quality sensor.
- Return air quality sensor (duct-mounted) (attached picture).
- Sensor installed on the master unit of the shared network (SHRD).
- Double quality sensor:
  - two ambient air sensors;
  - one ambient air sensor and one outdoor air sensor;
  - one return air sensor (duct-mounted) and one outdoor air sensor.



#### Advantages of installing two ambient air quality sensor:

This installation is interesting in large premises, so that ventilation can be done based on the maximum, minimum or average value measured by the two sensors.

#### Advantages of installing an outdoor CO<sub>2</sub> air quality sensor:

This sensor gives the option to manage fresh air depending on real difference of CO<sub>2</sub> concentration indoor and outdoor<sup>(1)</sup>. It gives the chance to really answer to the request of indirect method for ventilation, without need of estimating outdoor air quality, but measuring it.

<sup>(1)</sup> Outdoor sensor will be supplied not mounted. It has to be located outdoor, but protected from rain and external agents. For any doubt, please ask.

#### Options recommended for fresh air management:

Local	Outdoor	Recommendation
Constant occupation	Applied to all locations	Constant fresh air (fresh air % fixed by regulation). No additional option required
Variable occupation	Locations where outdoor CO <sub>2</sub> is well known	Variable fresh air (considering indoor CO <sub>2</sub> concentration): <ul style="list-style-type: none"> <li>• Ambient air quality sensor</li> <li>• Return air quality sensor</li> <li>• Double ambient sensor (in large scale premises)</li> </ul>
	Locations where outdoor CO <sub>2</sub> is not well known or variable	Variable fresh air (considering indoor and outdoor CO <sub>2</sub> concentration): <ul style="list-style-type: none"> <li>• Double air quality sensor: ambient and outdoor</li> <li>• Double air quality sensor: return and outdoor</li> </ul>

#### Methodologies fresh air ratio calculation:

The categories of indoor air quality (IEQ) are defined in EN16798:1 based on the level of expectation that the occupants may have.

- A normal level would be a “medium” level.
- A higher level can be selected by occupants with special needs (children, elderly, people with disabilities, etc).
- A lower level does not mean any risk for health, but it can affect to comfort level.

Category IEQ	DIRECT METHOD: Fresh air ratio by person	INDIRECT METHOD: CO <sub>2</sub> concentration above outdoor CO <sub>2</sub> concentration
	dm <sup>3</sup> /s by person	ppm
I: High level of expectation	20	550
II: Medium level of expectation	12,5	800
III: Moderate level of expectation	8	1.350
IV: Low level of expectation	5	1.350

**References:** EN 16798-3:2017 and EN 16798-1:2019: Energy performance of buildings - Ventilation for buildings, replacing EN 13779:2007.

### Free-cooling + outdoor humidity

- **Outdoor air humidity** sensor (compulsory in units with optional enthalpic or thermoenthalpic free-cooling).

When the unit needs the outdoor humidity probe, this one is connected on the board in place of the NTC ambient temperature probe. In this case, an RS485 ambient temperature probe connected to the Field-bus is used.

There are 2 options:

- Sensor supplied with the unit (for duct installation).
- Sensor installed on the master unit of the shared network (SHRD).

## FACTORY OPTIONS AND ACCESSORIES

■ **Free-cooling management:** Running the unit in free-cooling mode allows it to make best use of outdoor air conditions when these are more favourable than the return air conditions. This allows the cooling capacity to be reduced. The percentage of outdoor air can vary between 0% and 100%.

There are three options for free-cooling management:

- Thermal, by comparing the temperatures.
- Enthalpic, by comparing the enthalpies. Recommended in cases where a high moisture content in the air is foreseen.
- Thermoenthalpic, by comparing the enthalpies and correcting for temperature. This is the optimum solution as it takes the variability of the climate into account.

Thermal free-cooling

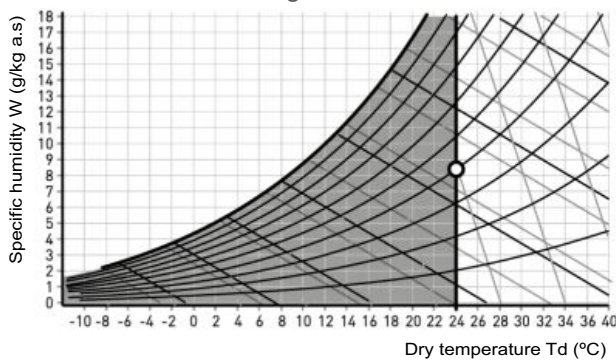

Enthalpic free-cooling

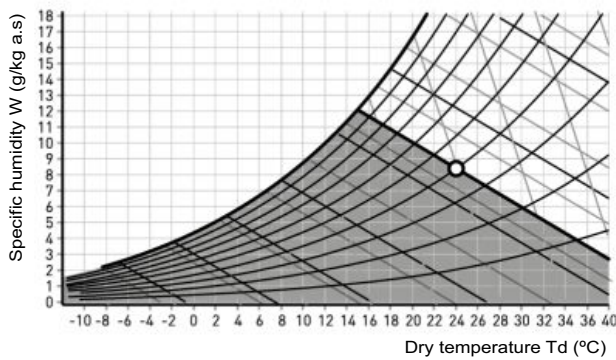

Thermoenthalpic free-cooling

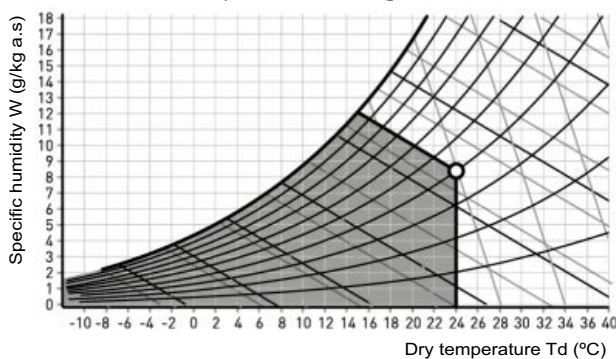

One function that helps improve energy management is **nocturnal free-cooling**. This feature allows the compressors to be disabled in summer with programming, the unit works providing free-cooling at night, when the outdoor conditions are favourable. This allows the cooling demand to decrease significantly early in the day.

### Terminal + unit communication

■ By default, the electronic control is supplied with a Graphic terminal installed in the electrical cabinet of the unit, but these other configurations also are available:



Graphic terminal



User terminal

- Graphic terminal installed in the electrical cabinet and User terminal remote up to 100 meters.
- Graphic terminal installed in the electrical cabinet and Graphic terminal remote up to 200 meters (two TCONN bypass cards must be used from 50 to 200 meters).
- User terminal installed in the electrical cabinet, instead of the graphic terminal.
- User terminal installed in the electrical cabinet and Graphic terminal remote up to 200 meters (two TCONN bypass cards must be used from 50 to 200 meters).

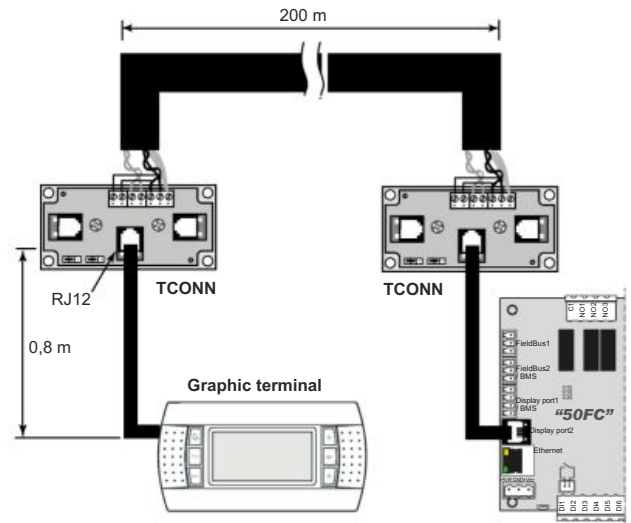

- Control without terminal (for units with shared terminal in a pLAN local network).

Note: Multiple units can share a terminal if they are integrated into a local pLAN network (for up to 15 units). This is not possible in units configured as "Backup", since the two units must be fully autonomous in their operation.

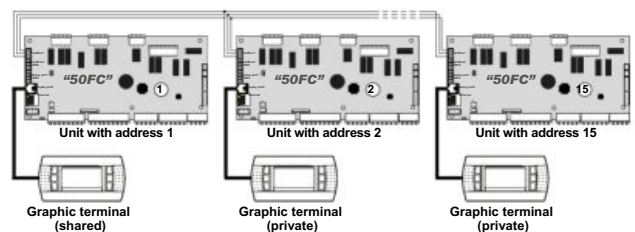



## FACTORY OPTIONS AND ACCESSORIES

- By default, the electronic control is configured for a stand-alone unit, but it is also possible to include it in an shared network (SHRD) as Master, Slave or Backup. The maximum number of units that can be integrated into an "Master/Slave" shared network is 15, and in the case of "Backup" it is 2 units.

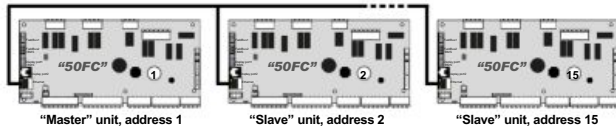

Important: to use any of the following functionalities it is necessary to configure in the "Selection Program" a unit as Master and all other units as Slaves (including the Backup unit).

The specific functionality will be configured on site (according to the "50FC" regulation manual).

The shared network (SHRD) allows to have the following functionalities depending on the parametrized configuration:

### - Master/Slave:

It allows the sharing of some of the probes installed in the Master unit: ambient temperature or ambient temperature + humidity, outdoor temperature, outdoor humidity and CO<sub>2</sub> air quality.

Important: These probes can only be shared if installation features allow it.

### - Extended Master/Slave:

It includes "Master/Slave" functionalities and the master unit provides ambient temperature setpoints to the other units.

### - Master/Slave with the same operating mode:

It includes the "Extended Master/Slave" functionalities and the master unit also provides the status (Cooling-Heating - Ventilation) to the other units.

### - Backup in case of alarm:

One unit is configured as a Backup unit, for activation in case of malfunction of the other unit.

### - Extended Backup:

It includes the "Backup in case of alarm" functionalities and also, the control manages the automatic switching between the two units weekly, to compensate the operation times of both units.

Note: In the case of installations with Backup units, it is not possible to share the probes, since both units must be fully autonomous in their operation. If both units are connected to the same supply duct network, it is imperative that the installation consists of non-return dampers (installer responsibility).

- The control board includes two communication ports that allow connection with a centralized technical management system: a BMS port for Modbus RTU protocol and an Ethernet port for Modbus TCP/IP protocol.

A communication card (optional) can also be connected to the board for the following protocols:

- Ethernet BACnet™ (B: Ethernet BACnet™ card),
- BACnet™ MSTP (C: RS485 BACnet™ card),
- Konnex (K: RS485 Konnex card),

Note: refer to the electronic control manual for more complete information.

## Local supervision solutions

Different solutions of supervision are available bases on the dimensions of the installation:

### - pCO Web:

It is a solution for the management and supervision of a single unit through an HTML page included in the Ethernet pCO Web card.

### - BOSS:

This is the solution for the management and supervision of air-conditioning installations with up to 300 units. Communication is via the Modbus TCP/IP port integrated into the control board.

Its main advantages are:

- Integrated WIFI Hotspot for direct access without any extra infrastructure.
- Smartphone compatibility.
- Secure supervisor control from remote through a simple browser.

It offers advanced monitoring and maintenance functions and allows zones and groups to be created to simplify the management of the installation.

It also allows energy meters to be integrated to monitor the installation electricity consumption.

BOSS is available in two versions:

- CPU device.
- CPU device, monitor, mouse and keyboard.

### - BOSS mini:

This is the solution for the management and supervision of air-conditioning installations with up to 10 units with 50 variables per unit or 50 units with 10 variables maximum per unit, but with the same features as BOSS.

BOSS mini is available in two versions:

- CPU device.
- CPU device, monitor, mouse and keyboard.

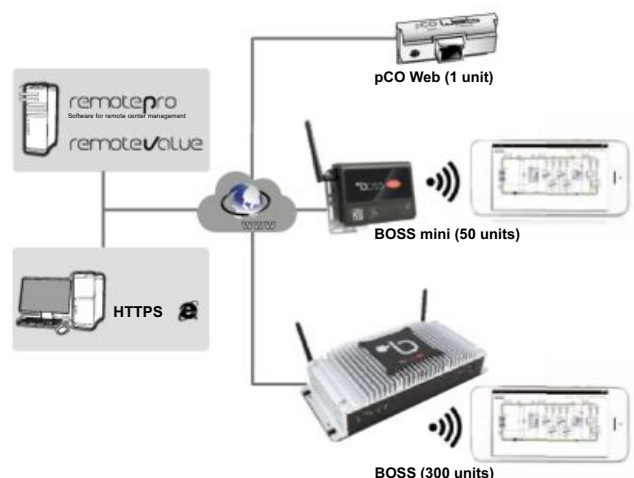

These systems are used to manage the installation remotely. All the information on the system can be accessed via a simple Internet connection.

The online interface, the same one used by the local user, enables monitoring and complete configuration of the installation: from the office or anywhere else the user happens to be.

## FACTORY OPTIONS AND ACCESSORIES

### Remote supervision solution

**ABOUND HVAC Performance** is a remote supervision solution dedicated to monitoring and controlling several CARRIER machines in real time.



### Advantages

- Access to the operating trend curves for analysis
- Improved energy performance
- Improved availability rate for the machines

### Functions

ABOUND HVAC Performance will send data in real time to the supervision website.

The machine operating data can be accessed from any PC, smartphone or tablet.

Any event can be configured to trigger a mail alert.

Parameters monitored:

- Overview.
- Control panel for the controllers.
- Events.
- Temperature curves.

Monthly and annual reports are available to analyse :

- The performance and operation of the machine.

Example: operating curves and time, number of compressor start-ups, events, preventive maintenance actions to be performed, etc.

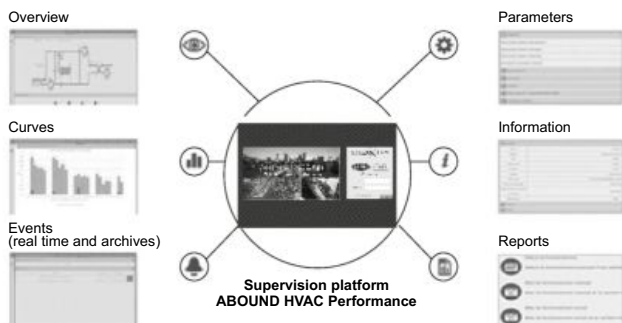

Incidents such as a drift in the measurements on a temperature sensor, incorrectly set control parameters, or even incorrect settings between one compressor stage and the other are immediately detected, and the corrective actions put in place.

### Equipment

This kit box can be used on both machines which are already in use (existing inventory), and on new machines.

- 1 transportable cabinet.

### Contents of the box (available in 230V and 400V)

- 1 GPRS / 4G LTE-M modem
- 1 SIM SMART card
- 1 power supply (24 VDC)
- 1 power protection device
- 1 GSM antenna
- Rail mounting
- Enclosed casing to protect the equipment during transport
- Packing box for cable routing (bus, power supply)

### Compatibility

Up to five machines per box.

### Miscellaneous item 1

- **Energy meter** for monitoring of the power consumption of the installation.
- **Energy meter and calculation** of the cooling and heating capacities. In addition to the energy meter, the unit incorporates mixing and supply enthalpic sensors with RS485 communication that enable cooling and heating capacities to be calculated.
- **Tropicalization**: tropicalized components on the electrical cabinet with protective varnish: control board, cards and terminals.

### External mixing box

Note: The recommendation is to select CS assembly instead C0 for fresh air and free-cooling management. But if for any reason the mixing box supplied with CS assembly does not fit the need of the installation, this option for external mixing box can be selected.

- **External mixing box with 2 dampers.** Management of the dampers of an external mixing box not supplied (to manage fresh air and free-cooling).

This option is only available with C0 assembly. In this case, it is possible to choose the "Group U" sensors (free-cooling / outdoor humidity).

- **External mixing box with 3 dampers.** Management of the signal control for dampers and fans of an external mixing box not supplied (to manage fresh air and free-cooling).

In this case, in addition to the sensors of the previous option, the electrical cabinet incorporates two terminals with 230Vac output for activation of the contactor that the customer must install to power its return fan. This output is activated simultaneously with the 50NC unit supply fan.



## FACTORY OPTIONS AND ACCESSORIES (SUMMARY)

Family	Group	Description	Installation in factory	Installation on site
<b>Unit type</b>	C	Package (C) or Split (P)	X	
<b>Air direction</b>	D	00: Lateral - Lateral	X	
		01: Lateral - Upper	X	
		10: Upper - Lateral	X	
		11: Upper - Upper	X	
<b>Electrical power</b>	F	400 V / 3 ph / 50 (without neutral)	X	
<b>Assembly</b>	H	CS: Assembly with 2 dampers mixing box		X
<b>Coil coating</b>	I	Coil with copper pipes and fins of an aluminium alloy INERA®	X	
<b>Auxiliary heating</b>	J	Auxiliary electrical heaters	X (*)	
<b>Indoor fan</b>	L	Supply plug-fan of high available pressure	X	
<b>Air filtration + stop-drop</b>	M	Stop-drop in the indoor air coil	X	X
		G4 gravimetric filters with low pressure drop	X	X
		G4 gravimetric filters + F7 opacimetric filters	X	X
		G4 gravimetric filters with low pressure drop + F7 opacimetric filters	X	X
<b>Indoor circuit</b>	P	Compressor insulation	X	X
		Differential pressure switch to detect clogged filters	X	
<b>Outdoor circuit</b>	Q	Service valves and refrigerant precharge (Split version)	X	
		Long distance (Split version)		X
		Antivibration mounts made of rubber		X
<b>Extra heating</b>	R	Heat recovery coil	X (*)	
<b>Special applications</b>	S	Air zoning	X (*)	
		Constant supply pressure	X (*)	
		Low return temperature application	X	
<b>Sensors</b>	T	Ambient temp. sensor: 1 NTC sensor connected to the control board or 1 to 4 RS485 sensors	X	X
		Ambient temperature + humidity sensor: 1 to 4 sensors with RS485 communication	X	X
		Air quality sensor environment installed, duct-mounted, on a shared network (SHRD) or double sensor (environment + environment; environment + outdoor; duct-mounted + outdoor)	X	X
		Smoke detecting station in accordance with the NF S 61-961 standard	X	X
<b>Free-cooling + Outdoor humidity</b>	U	Type of free-cooling: thermal, enthalpic or thermoenthalpic	X	X
		Outdoor air humidity sensor: supplied with the unit or installed on a shared network (SHRD)	X	X
<b>Terminal + Unit communication</b>	V	User terminal installed in the electrical cabinet	X	X
		Graphic terminal installed in the electrical cabinet + User terminal remote up to 100 m	X	X
		User terminal installed in the electrical cabinet + Graphic terminal remote up to 200 m	X	X
		Graphic terminal installed in the electrical cabinet + Graphic terminal remote up to 200 m	X	X
		Unit configuration: stand-alone, master or slave	X	X
		Communication cards: Ethernet BACnet™; RS485 BACnet™; RS485 Konnex	X	X
<b>Miscellaneous item 1</b>	W	Energy meter	X	
		Energy meter and calculation of the cooling and heating capacities	X	
		Tropicalised components on the electrical cabinet: control board, cards and terminals	X	
<b>External mixing box</b>	X	External mixing box with 2 dampers		X
		External mixing box with 3 dampers		X

(\*) Part of this option must be installed on-site.

## ADDITIONAL FACTORY OPTIONS UPON REQUEST

This chapter contains other options available upon request, in addition to those indicated in the table above:

■ **Activation of the remote COOLING / HEATING operating mode.** The electronic control allows the operating mode switching by a digital input of an input/output expansion module.

■ **General alarm signalling.** The “50FC” control allows the management of a relay for remote alarm signalling.

The output for general alarm signal is not compatible with the heat recovery coil. In this case, upon request, it would be possible to have a general alarm output in an input/output expansion module.

■ **Ventilation with differential air pressure sensor.** In installations with this differential pressure sensor, the percentage of air renewal is adjusted according to the pressure in the room. This option allows dynamic control of the damper opening by measuring the pressure differential between inside and outside.

■ **Mechanical disconnection of stages.** This option allows the mechanical disconnection of stages of compressor and/or electrical heaters using digital inputs. This is especially useful in the following cases:

- To reduce electricity consumption in certain time slots.
- When electricity consumption is limited.

■ **Control of supply and return dampers.** This function allows the management of external supply and return dampers located in the ducts, so that the closure of the ducts can be controlled after the unit is stopped. This option can also be useful in installations with Back-up units.

Description of options upon request	Installation in factory	Installation on site
Activation of remote COOLING / HEATING mode	X	
General alarm signalling by relay	X	
Ventilation with differential pressure sensor		X
Mechanical disconnection of stages	X	
Control of supply and return dampers		X

## TECHNICAL CHARACTERISTICS (EN-14511-2022)

50NC series		022	028	038	042	058	064	074	086	106	118
<b>Cooling capacities</b>											
Cooling capacity (1)	kW	Coming soon	34,3	39,8	56,8	62,1	70,4	81,5	Coming soon		
Power input (3)	kW		13,1	16,6	19	21,8	26,8	34,1			
EER performance			2,62	2,39	2,99	2,85	2,63	2,39			
SEER			4,13	3,95	4,59	4,37	4,14	4,03			
$\eta_s$			162%	155%	180%	172%	162%	158%			
<b>Heating capacities</b>											
Heating capacity (2)	kW	Coming soon	34,4	40,4	54,7	62,2	71,2	83,4	Coming soon		
Power input (3)	kW		11,5	13,9	16,9	19,9	23,1	28,4			
COP performance			2,98	2,91	3,24	3,12	3,08	2,94			
SCOP			3,41	3,27	3,30	3,27	3,26	3,25			
$\eta_s$			133%	128%	129%	128%	127%	127%			
<b>Outdoor module fan</b>											
Electronic plug-fan											
Nominal air flow	m <sup>3</sup> /h	Coming soon	14.000	14.500	27.300	27.300	29.500	29.500	Coming soon		
Nominal available static pressure	Pa		150	150	100	100	100	100			
Number / Diameter	mm		1 / 560	1 / 560	2 / 560	2 / 560	2 / 560	2 / 560			
Maximum speed	r.p.m.		1.495	1.495	1.495	1.495	1.495	1.495			
Motor output	kW		1 x 3,1	1 x 3,1	2 x 3,1	2 x 3,1	2 x 3,1	2 x 3,1			
Maximum absorbed current	A		1 x 4,6	1 x 4,6	2 x 4,6	2 x 4,6	2 x 4,6	2 x 4,6			
<b>Indoor module fan</b>											
Electronic plug-fan											
Nominal air flow	m <sup>3</sup> /h	Coming soon	7.000	7.400	11.000	12.600	14.400	15.200	Coming soon		
Nominal available static pressure	Pa		150	150	150	200	200	200			
Maximum available static pressure	Pa		650	592	827	701	522	439			
Number / Diameter	mm		1 / 500	1 / 500	2 / 500	2 / 500	2 / 500	2 / 500			
Maximum speed	r.p.m.		1.800	1.800	1.800	1.800	1.800	1.800			
Motor output	kW		1 x 3,04	1 x 3,04	2 x 3,04	2 x 3,04	2 x 3,04	2 x 3,04			
Maximum absorbed current	A	1 x 4,7	1 x 4,7	2 x 4,7	2 x 4,7	2 x 4,7	2 x 4,7				
<b>Compressor</b>											
Scroll											
No. compressors / stages / circuits		2 / 2 / 1				4 / 4 / 2					
Oil type		Copeland 3MAF 32cST, Danfoss POE 160SZ, ICI Emkarate RL 32CF, Mobil EAL Artic 22CC									
Volume of oil	l	Coming soon	3,5	3,5	4,8	6,8	7,1	7,2	Coming soon		
<b>Electrical characteristics</b>											
Mains voltage		400 V / III ph / 50 Hz ( $\pm 10\%$ )									
Power supply		3 Wires + Ground + Neutral									
Maximum absorbed current	A	Coming soon	33,4	38,0	56,2	59,2	66,8	76,0	Coming soon		
Starting current	A		96,8	125,1	98,8	116,6	130,2	163,1			
<b>Refrigerant connections (Split version)</b>											
Circuit 1: Liquid line		Coming soon	5/8"	5/8"	5/8"	5/8"	5/8"	5/8"	Coming soon		
Circuit 1: Gas line			1 1/8"	1 1/8"	1 1/8"	1 1/8"	1 1/8"	1 1/8"			
Circuit 2: Liquid line			-	-	5/8"	5/8"	5/8"	5/8"			
Circuit 2: Gas line			-	-	1 1/8"	1 1/8"	1 1/8"	1 1/8"			
<b>Refrigerant</b>											
R-410A											
Global warming potential (4)	GWP	2.088									
Charge in Package version	kg	Coming soon	8,6	9,4	11,3	14,9	15,5	15,8	Coming soon		
Environment impact	tCO <sub>2</sub> e		17,9	19,6	23,5	31,1	32,4	33,1			
Charge up to 7,5 m in Split version (opt.)	kg		9,2	10,1	12,5	16,2	16,8	17,1			
Environment impact	tCO <sub>2</sub> e		19,3	21,0	26,1	33,7	35,0	35,7			

(1) Cooling capacity calculated in accordance with the EN-14511-2022 standard given for indoor temperature conditions 27°C, 19°C WB and 35°C outdoor temperature.

(2) Heating capacity calculated in accordance with the EN-14511-2022 standard given for indoor temperature conditions 20°C and 6°C WB outdoor temperature.

(3) Total power input by compressors and motorised fans under nominal conditions, calculated in accordance with the EN-14511-2022 standard.

(4) Climatic warming potential of a kilogram of fluorinated greenhouse gas in relation to a kilogram of carbon dioxide over a period of 100 years.

## OVERALL DIMENSIONS

50NC series	Package unit			Split unit: Outdoor module			Split unit: Indoor module			Mixing box (CS assembly)		
	A (mm)	B (mm)	C (mm)	A (mm)	B (mm)	C (mm)	A (mm)	B (mm)	C (mm)	A (mm)	B (mm)	C (mm)
022 to 028	Coming soon			Coming soon			Coming soon			Coming soon		
038 to 042	1.640	1.030	2.175	1.640	895	1.520	1.640	1.030	735	1.640	890	735
058 to 086	2.900	1.030	2.175	2.900	895	1.520	2.900	1.030	735	2.900	890	735
106 to 118	Coming soon			Coming soon			Coming soon			Coming soon		

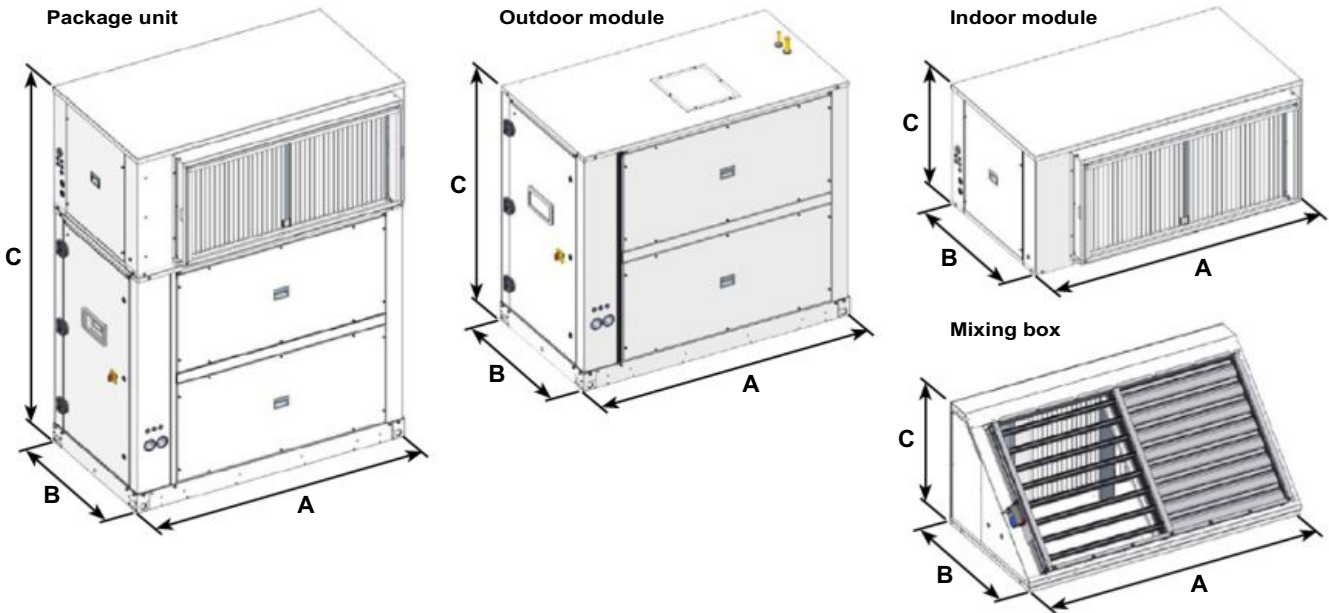

## WEIGHT OVERVIEW

50NC series	022	028	038	042	058	064	074	086	106	118
Package unit (kg)	Coming soon		638	643	1.069	1.098	1.109	1.116	Coming soon	
Split unit: Outdoor module (kg)	Coming soon		444	447	758	781	789	796	Coming soon	
Split unit: Indoor module (kg)	Coming soon		203	203	330	330	364	364	Coming soon	

## Weight supplement from the main options (kg)

50NC series	022	028	038	042	058	064	074	086	106	118
Mixing box (CS assembly)	Coming soon		71	71	108	108	108	108	Coming soon	
Supply fan	High pressure (H)		2	2	5	5	5	5	Coming soon	
	G4 l.p.d.		1	1	2	2	2	2	Coming soon	
Filters	G4 + F7		5	5	10	10	10	10	Coming soon	
	G4 l.p.d. + F7		6	6	12	12	12	12	Coming soon	
Stop-drop	Indoor coil		17	17	35	35	35	35	Coming soon	
	E0L (Low)		19	19	36	36	36	36	Coming soon	
	E0N (Nominal)		22	22	38	38	38	38	Coming soon	
Electrical heaters	E0H (High)		25	25	43	43	43	43	Coming soon	
	Empty		35	35	54	54	54	54	Coming soon	
Heat recovery coil	In service		53	53	87	87	87	87	Coming soon	
	Valves and refrigerant precharge (Split version)		9	10	13	16	17	17	Coming soon	
Long distance (Split version)	Coming soon		5	5	9	9	9	9	Coming soon	

## SOUND LEVELS dB(A)

### Sound power level (LW)

#### Package unit

50NC series	022	028	038	042	058	064	074	086	106	118
63 Hz	Coming soon		57	60	62	62	59	69	Coming soon	
125 Hz			66	75	72	72	74	72		
250 Hz			74	74	79	78	76	77		
500 Hz			81	81	83	84	82	82		
1000 Hz			84	84	85	85	86	86		
2000 Hz			84	84	82	83	84	84		
4000 Hz			77	77	78	78	77	78		
8000 Hz			68	72	72	72	69	73		
Total dB(A)					88	89	89	89		

#### Split unit: Outdoor module

50NC series	022	028	038	042	058	064	074	086	106	118
63 Hz	Coming soon		54	57	59	59	56	66	Coming soon	
125 Hz			63	72	69	69	71	69		
250 Hz			71	71	76	75	73	74		
500 Hz			78	78	80	81	79	79		
1000 Hz			81	81	82	82	83	83		
2000 Hz			81	81	79	80	81	81		
4000 Hz			74	74	75	75	74	75		
8000 Hz			65	69	69	69	66	70		
Total dB(A)					83	83	86	86		

#### Split unit: Indoor module

Sound power level in the indoor fan supply to be taken into account for the silencer calculation:

50NC series	022	028	038	042	058	064	074	086	106	118
63 Hz	Coming soon		72	75	71	70	72	76	Coming soon	
125 Hz			68	71	67	67	69	72		
250 Hz			69	72	69	70	71	75		
500 Hz			73	76	73	73	77	78		
1000 Hz			73	76	73	74	75	78		
2000 Hz			69	72	69	70	72	75		
4000 Hz			63	66	63	64	66	69		
8000 Hz			56	59	55	57	60	63		
Total dB(A)					79	82	79	79		

### Sound pressure level (LP)

Measurement conditions: in a clear field, measured at a distance of 10 metres, directivity 2 and at 1,5 metres from the ground.

Note: The sound pressure level depends on the installation conditions and, as such, it only indicated as a guide. Values obtained according to the ISO 3744 standard.

#### Package unit

50NC series	022	028	038	042	058	064	074	086	106	118
Total dB(A)	Coming soon		55	55	56	57	57	57	Coming soon	

#### Split unit: Outdoor module

50NC series	022	028	038	042	058	064	074	086	106	118
Total dB(A)	Coming soon		53	53	55	55	55	55	Coming soon	

## REFRIGERANT CONNECTIONS (SPLIT VERSION)

In the case of separate installation of the outdoor and indoor modules the following recommendations should be followed:

### Outdoor module top

Maximum equivalent length of the refrigerant line: 50 metres

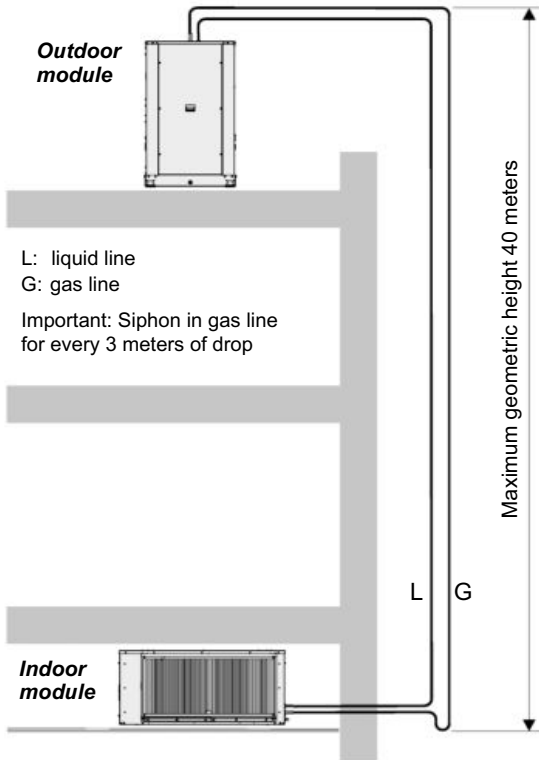

### Outdoor module bottom

Maximum equivalent length of the refrigerant line: 30 metres

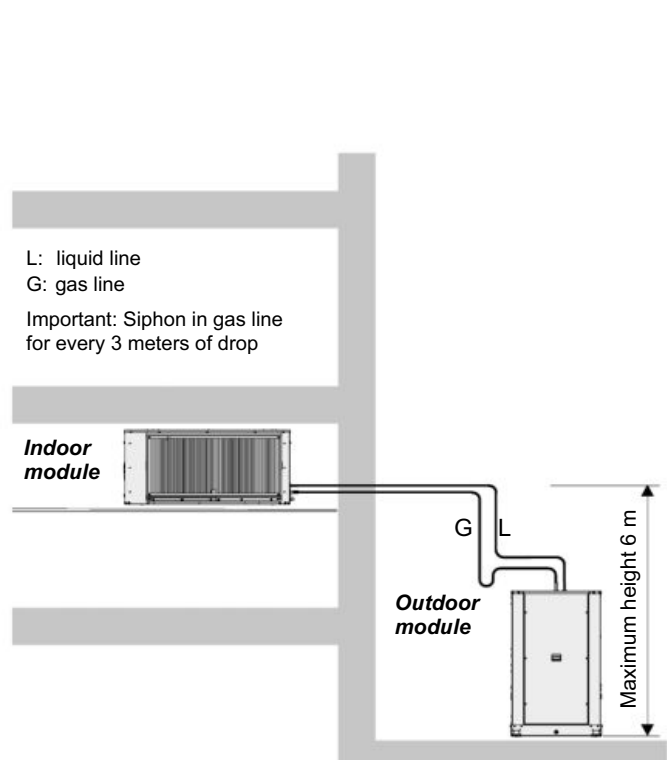

- The maximum equivalent length of the refrigerant line is 50 meters, with a maximum geometric height of 40 meters when the outdoor module is above. For longer distances, up to 100 meters maximum, it is necessary to use an oil separator per refrigerant circuit (long distance option).
- The maximum equivalent length of the refrigerant line is 30 meters, with a maximum geometric height of 6 meters when the indoor module is above.

### Refrigerant connections

50NC series		022	028	038	042	058	064	074	086	106	118
Circuit 1	Liquid line: Circuit 1	Coming soon		5/8"	5/8"	5/8"	5/8"	5/8"	5/8"	Coming soon	
	Gas line: Circuit 1			1 1/8"	1 1/8"	1 1/8"	1 1/8"	1 1/8"	1 1/8"		
	Charge up to 7.5 m (optional) (kg)			9,20	10,10	6,25	8,10	8,40	8,55		
Circuit 2	Liquid line: Circuit 2			--	--	5/8"	5/8"	5/8"	5/8"		
	Gas line: Circuit 2			--	--	1 1/8"	1 1/8"	1 1/8"	1 1/8"		
	Charge up to 7.5 m (optional) (kg)			--	--	6,25	8,10	8,40	8,55		

### R-410A refrigerant charge

- As an option, the unit can be supplied service valves for refrigerant connections and refrigerant precharge for a maximum distance between the outdoor module and the indoor module of 7.5 meters.
- If the equivalent length of the refrigerant lines is greater than 7.5 meters, an additional charge per metre must be carried out according to the following table:

Nominal diameter (inches)	1/4"	3/8"	1/2"	5/8"	3/4"	7/8"	1"	1 1/8"
Interior section (cm <sup>2</sup> )	0,2	0,5	1,0	1,6	2,4	3,3	4,4	5,6
Liquid line charge (g/m)	17,5	48,1	93,9	154,8	229,6	318,9	422,2	539,3
Gas line charge (g/m)	-	0,2	0,3	0,6	0,8	1,2	1,5	2,0



## ELECTRICAL CONNECTIONS

The following connections must be made on site by the customer:

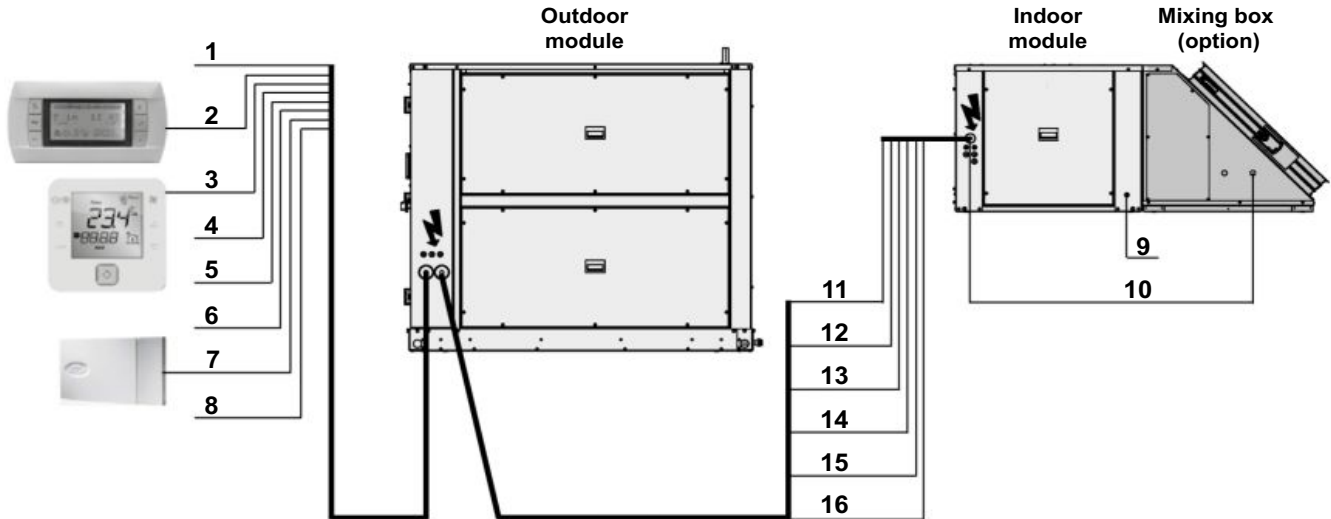

50NC	No.	Connections	022 to 028	038 to 042	058 to 086	106 to 118	
Package and Split versions	1	Main power supply	Standard unit	Coming soon	5G 25A x 10 mm <sup>2</sup>	5G 25A x 10 mm <sup>2</sup>	Coming soon
		400 III (±10%)	With electrical heaters (opt.)		5G 63A x 35 mm <sup>2</sup>	5G 63A x 35 mm <sup>2</sup>	
	2	Remote connection of Graphic terminal (by default installed on the electrical cabinet) (1)	Telephone cable 6 wires standard (RJ12 connector)				
	3	Connection of User terminal (optional) (2)	2 x 1 mm <sup>2</sup> (230V) + 1 shielded cable for communication type AGW20 / 22 (1 braided pair + drainwire + shielding)				
	4	Remote off/on (optional)	2 x 1 mm <sup>2</sup>				
	5	General alarm signal (optional) (3)	2 x 1 mm <sup>2</sup>				
	6	Remote Cooling/Heating (optional upon request)	2 x 1 mm <sup>2</sup>				
	7	Ambient probe (4)	NTC	2 x 1 mm <sup>2</sup>			
			RS485	4 x 0,5 mm <sup>2</sup> + shielding (5)			
	8	Air quality probe (optional)	3 x 1 mm <sup>2</sup>				
9	Heat recovery coil (optional)	3 x 1 mm <sup>2</sup>					
10	Connection of mixing box (optional)	Standard (BOX3)	5 x 1 mm <sup>2</sup>				
		Enthalpique probe for energy measurement (BOX-ENT) (opt.)	4 x 0,5 mm <sup>2</sup> + shielding				
Split version	11	Power supply of the indoor module (W96)	Standard unit	Coming soon	4G x 2,5 mm <sup>2</sup>	4G x 2,5 mm <sup>2</sup>	Coming soon
		With electrical heaters (opt.)			4G x 10 mm <sup>2</sup>	4G x 16 mm <sup>2</sup>	
	12	Control of the indoor module (W30)	Standard unit	5 x 1 mm <sup>2</sup>			
			With mixing box (opcional)	7 x 1 mm <sup>2</sup>			
	13	Power supply of the indoor fan (230 Vac) (W5)	2 x 1 mm <sup>2</sup>				
	14	Control of the indoor fan (W90)	7 x 1 mm <sup>2</sup>				
15	Electrical heaters (W37) (opcional)	4 x 1 mm <sup>2</sup>					
16	Heat recovery coil (W53) (opcional)	4 x 1 mm <sup>2</sup>					

(1) In this case, it is possible to install the User terminal on the electrical cabinet.

(2) The power supply of the electrical cabinet (230 V) must be used for terminal power.

(3) The output for general alarm signal is not compatible with the heat recovery coil. With this option, possibility of general alarm upon request.

(4) The outdoor humidity probe (optional) is connected in the same place as the ambient NTC probe. In this case the ambient probe RS485 connected on the Field-bus will be used.

(5) Up to four RS485 ambient sensors can be connected in series on the field-bus of the control board.



## CARRIER® AND BARRISOL® ADVANCED HVAC CEILING SOLUTIONS



Architect KHR Arkitekter A/S. © Barrisol®

- Indoor air quality
- High energy efficiency
- Comfort
- Environmental sustainability
- Aesthetics

## Barrisol Clim® and Barrisol Cloud Clim® featuring Carrier® products

The alliance between two global leaders to provide outstanding opportunities for comfort, well-being, and aesthetics.

### **Carrier®: the world leader in healthy, safe, sustainable and intelligent building solutions**

Carrier® is the leading global provider of healthy, safe, sustainable and intelligent building and cold chain solutions.

For over a century, we have been developing innovative products and services that have changed the way people live and work. That drive for innovation continues today with a renewed focus on creating solutions that will change the world for the better. At Carrier®, we see possibilities everywhere.

Built on Willis Carrier's invention of modern air conditioning in 1902, Carrier® is a world leader in heating, air-conditioning and refrigeration solutions. We constantly build upon our history of proven innovation with new products and services that improve global comfort and efficiency.

### **Barrisol®: the world leader of stretch ceilings**

Barrisol® Normalu® S.A.S. is the world leader for stretch ceilings and has been for more than 50 years.

The company has received more than 50 awards for its capacity to constantly innovate and create aesthetical, ecoresponsible and qualitative products.

Thanks to its high quality constitution, its adaptability to realize unique shapes and its high quality, Barrisol® stretch ceilings became and is the best choice for designers and architects. Their ceilings are 100% recyclable and up to 60% post consumer recyclable content.

"To make the world of tomorrow more beautiful, we first have to preserve it today".

Jean-Marc SCHERRER - President - Barrisol®



© Carrier® - Airside center of excellence Culoz -France



© Barrisol® - Production site of Kembs - France

## INNOVATIVE HVAC CEILING SOLUTIONS FOR THE MOST DEMANDING BUILDINGS

Carrier® and Barrisol® advanced HVAC ceiling solutions combine high-level air diffusion and thermal performances for users' unrivalled comfort. They supply a unique combination of enhancing comfort and indoor air quality in a large scope of building configurations: offices, restaurants, hotels, sports centers, industry, healthcare facilities, and more.

### Clim® and Pure Clim® HVAC ceiling solutions

Barrisol Clim® featuring Carrier® products combines a stretch ceiling with an air conditioning system. This solution allows for the **highest levels of aesthetic design**, the technical components being hidden by the ceiling. The solution not only delivers **outstanding thermal comfort**, generating a constant and uniform temperature but also ensures the **high levels of acoustic comfort**. Barrisol Clim® featuring Carrier® products can be upgraded with UV-C lamps for the Pure Clim® version to enhance **air indoor quality** even further.



Architect Jean-François Brodbeck - AMRS Architectes. © Barrisol®



© Carrier®

### Cloud Clim® HVAC modular solution

Barrisol Cloud Clim® featuring Carrier® products combined installations consist of **modular ceiling units** providing **air conditioning, lightning and acoustic treatment** to the room.

The solution automatically adapts the air diffusion flow according to the temperature of the air blown. The fan coil can be integrated into the Cloud Clim module (42EP only) or installed remotely (all Carrier® ducted fan coil ranges).

**Carrier® and Barrisol® HVAC ceiling solutions are part of Carrier's Healthy Buildings Program, an expanded suite of advanced solutions to help deliver healthy, safe, efficient, and productive indoor environments.**



© Barrisol®



© Barrisol®

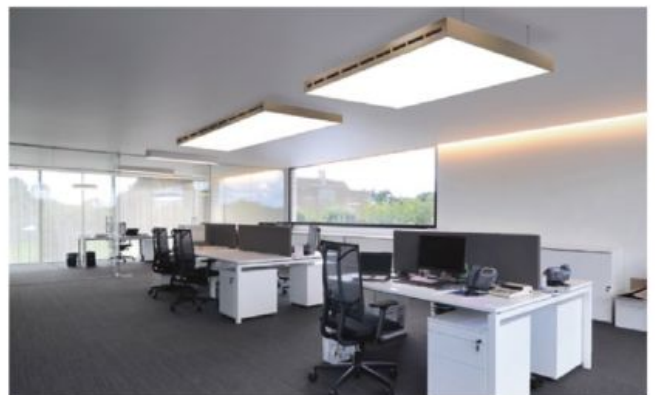

© Barrisol®



## INNOVATIVE HVAC CEILING SOLUTIONS FOR THE MOST DEMANDING BUILDINGS



### Indoor air quality

A+ class\* in air indoor quality  
High-efficiency air renewal

Indoor air disinfection with integrated UV-C light solution  
\* According to the French labeling of construction products



### High energy efficiency

High-performance design  
Lifetime equipment approach  
Compliance with Ecodesign requirements



### Comfort

High acoustic and thermal comfort  
Class A for cooling and heating  
according to the standard ISO 7730  
Uniform and constant temperature  
No draught



### Environmental sustainability

100% recyclable membranes and profiles  
Eco-responsible and sustainable  
manufacturing process



### Aesthetics

Technical components are hidden by the ceiling solution.  
100% customizable with lights, print design, shapes, and textures

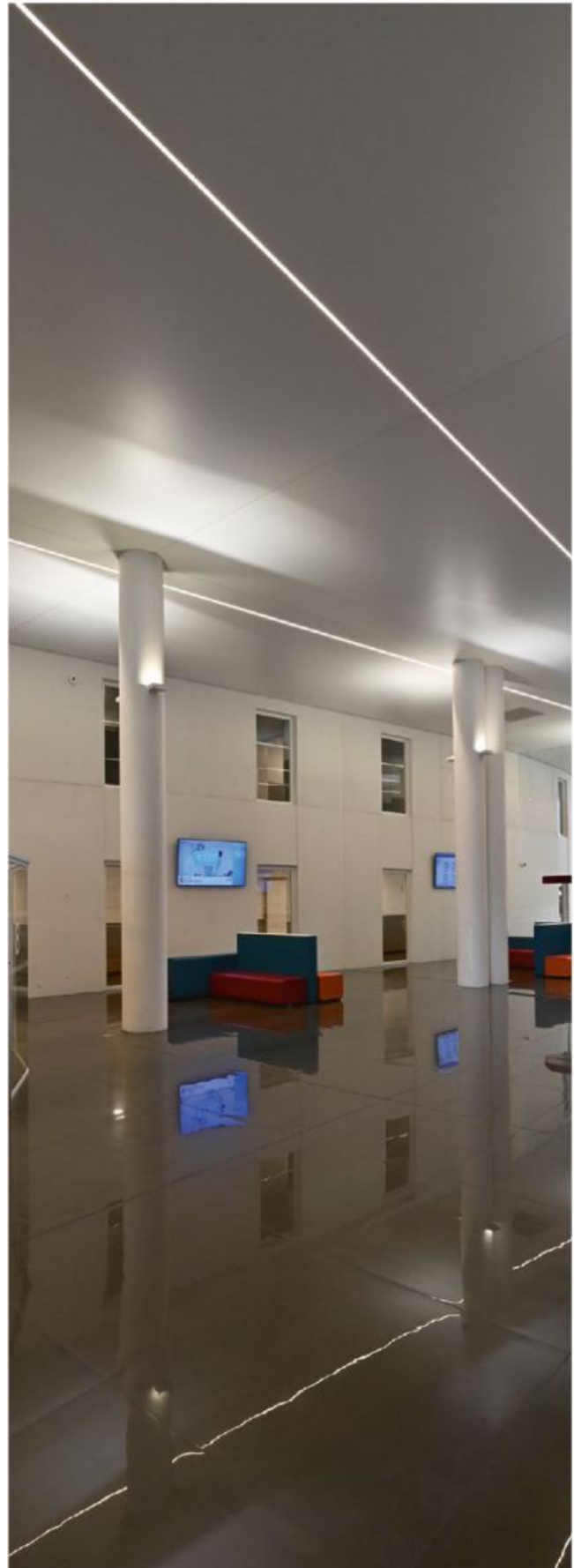

Architect Agence A+ Architecture. © Barrisol®

## BARRISOL CLIM® AND PURE CLIM® FEATURING CARRIER® PRODUCTS

The innovative combination of cutting-edge stretch ceiling solutions with a highly efficient HVAC system.

### The advanced hvac ceiling solution is based on two fundamental principles

Barrisol Clim® featuring Carrier® product technology uses radiation and convection. It uses a ceiling made from a bio-sourced membrane that is stretched and fixed in position, spanning a room. These ceiling acts like a high-level quality diffuser.

Combined with the responsiveness capacities of the Carrier® ducted fan coils, the solution is the perfect alliance for comfort and IAQ.

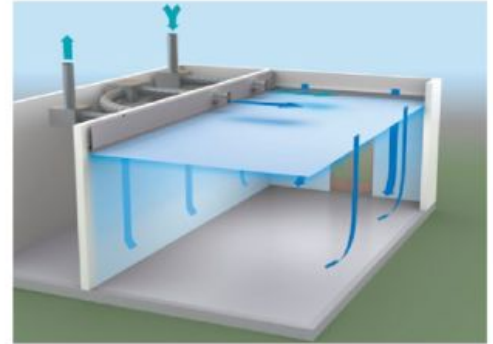

© Barrisol®



Arch. : KHR Arkitekter A/S. © Barrisol®

This solution consists of a ducted fan coil installed in the false ceiling or in an adjacent room that supplies cooled or heated air to the upper part of the stretch ceiling.

The high-efficiency Carrier® fan coils offers **high responsiveness and excellent capacities** to manage rapid load changes. The warm or cool conditioned air will flow gently over the inner walls, eliminating any unpleasant hot or cold walls-effect. A natural flow of air develops throughout the space, **at speeds so low that they are barely perceptible.**

At the same time, the canvas performs its radiant capacities becoming a huge diffuser: heat or cold radiates through its entire surface providing pleasant, gentle heating or cooling.



## BARRISOL CLIM® AND PURE CLIM® FEATURING CARRIER® PRODUCTS

### Comfort and well-being

#### Thermal comfort

The solution achieves a comfort rating of **Class A** for both cooling and heating, the highest possible under ISO 7730, the relevant international standard for measuring thermal comfort in buildings.

Thermal comfort scale according to ISO 7730\*

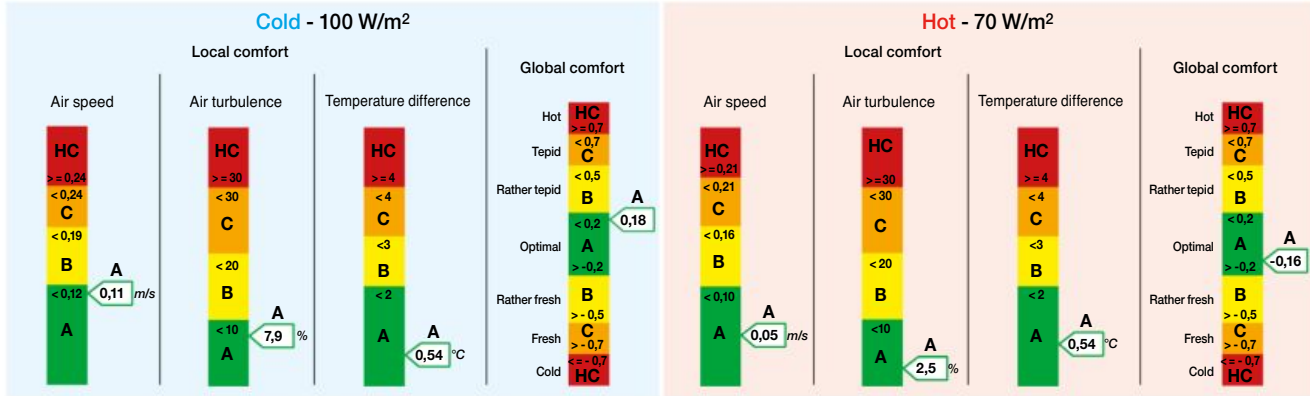

\* Tests carried out in the Jean Falconnier laboratory at the Carrier - Culoz site. Additional information available on request

The performances of the Carrier® fan coils ensure a **constant temperature**, whether in cooling or heating, regardless of the outdoor conditions. Combined with the thermal properties of the canvas it gives the system incredible responsiveness, in only a few minutes the sensation of heating or cooling is perceptible.

The HVAC ceiling system evens out the temperature of walls and ambient air, everywhere in the room for a **homogeneous temperature**, less than a 1.0°C temperature difference between the head and feet of the occupants (1.0°C in heating mode and 0.5°C in cooling mode).

It achieves almost **imperceptible air velocity** (0,12 m/s).

Barrisol Clim® featuring Carrier® fan coils technology thus offers an **unequaled level of comfort** since it is the only one able to create such a low airspeed while ensuring a homogeneous temperature throughout the room and a complete renewal air volume of the room (According to ISO7730. Tests carried out by Carrier® Culoz Laboratory).

#### Acoustic comfort

With their **very low noise** EC fan motor and **acoustic insulation**, the Carrier® fan coil units make silent operation a reality.

The special design of the microperforated membrane of the ceiling and its sound absorption capacity significantly **reduces the resonance effect and improve the acoustic performance of the environment**.

Within the Clinique Saint Jean project, Carrier® and Barrisol® were able to propose a solution to answer to very high acoustic treatment requirements, due to the large volume of the reception hall, the height under the ceiling, and a high frequentation (entrances, exits, reception).



Architect Agence A+ Architecture. Clinique Saint Jean. © Barrisol®

## BARRISOL CLIM® AND PURE CLIM® FEATURING CARRIER® PRODUCTS

### Aesthetics

The system is **fully customizable: lights, print design, shapes, dimensions...** It integrates seamlessly within every building, **hiding all the technical components**, and giving architects and designers **freedom of expression**.

Flexible, the stretch ceiling can still be adapted once installed for space reshaping needs (in offices and open spaces for instance).



Architect KHR Arkitekter A/S. © Barrisol®

### High energy efficiency

The Carrier® fan coils are equipped with energy-efficient variable-speed LEC fan motors, known to achieve high performances while being particularly energy efficient.

Due to thermal radiation of the membrane, homogeneous and stable ambient temperature, the setpoint temperature can be lowered in heating mode or increased in cooling mode for an equal perceived temperature, resulting in lower energy consumption.

Thanks to the very low air velocity, the pressure losses are also very low (less than 5Pa\*), and the energy consumption is reduced even further (up to 15%\*\*).

### Environmental sustainability

Ceiling membranes are made from **100% recyclable material** that contains a plant-based plasticizer and are weak A+ class\* in terms of VOCs emissions (volatile organic compounds).

Support profiles are made from 80% recycled aluminum.

The primary environmental impact of HVAC equipment is due to the energy they use. Carrier® designs products that achieve **optimized energy performance** throughout the year and limit the indirect release of CO<sub>2</sub> associated with the consumption of electricity.

Carrier® products are **extensively tested** and maintained to a high level, thanks to an extended service offering to ensure the **best performance during the equipment's entire lifetime**.

\* According to ISO7730. Tests carried out by Carrier® Culoz Laboratory

### Indoor Air Quality

#### Complete air renewal

Air renewal is one of the most important actions to ensure good IAQ.

The Carrier® and Barrisol® HVAC ceiling solution can provide a total air circulation and volume renewal inside the room (According to Computational fluid dynamics (CFD)).

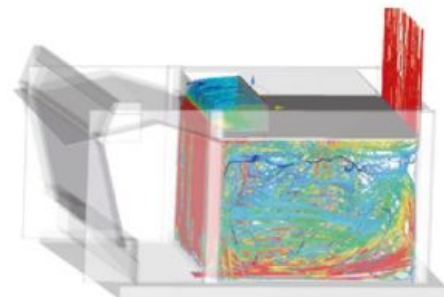

© Barrisol®

\* For information purpose only, vary according to room geometry (up to 3 meter high)

\*\* According to numerical simulations combine to laboratory testings. Depend on building type, localisation & conditions)

## BARRISOL CLIM® AND PURE CLIM® FEATURING CARRIER® PRODUCTS

### Rated A+

The solution has been rated A+ for indoor air quality, respecting the effective legislation\*. Barrisol® ceiling membranes are CE certified and fire-rated following the European and international norms (BS1-d0, BS2-d0, BS3-d0).

\* According to the French labeling of construction products. No emission of VCM (vinyl chloride monomer) detected during the warming of the sheet (50°C), the installation of the ceiling, or after installation.

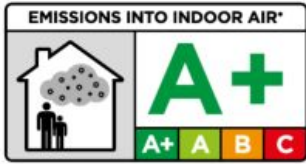

Information on the level of emission of volatile substances into the indoor air, presenting a risk of toxicity by inhalation, on a class scale from A+ (very low emissions) to C (high emissions).



Arch. : Filiptackdesignoffice & Devolder Architecten. © Barrisol®

### Air handling unit connection

As part of the Carrier® HVAC equipment, the advanced HVAC ceiling solution can be connected to a Carrier® air handling unit, to upgrade the level of air filtration.

### Barrisol Pure Clim® featuring Carrier® products

For air purification needs, the system can be upgraded with UV-C lamps.

The treated air is exposed to UV-C radiation throughout its path inside the plenum between the slab's natural part and the canvas.

The longer the air is exposed to UV-C radiation, the more effective the disinfection. Thanks to this configuration, the treated air injected into the plenum is exposed to UV-C radiation throughout its journey inside the plenum. Due to its large volume, the exposure time is particularly long, and therefore the disinfection is very effective : the room is disinfected at 99.9% in less than 30 minutes\*.

Thanks to the use of two specifically designed fabrics, UV-C radiation cannot escape from the plenum.

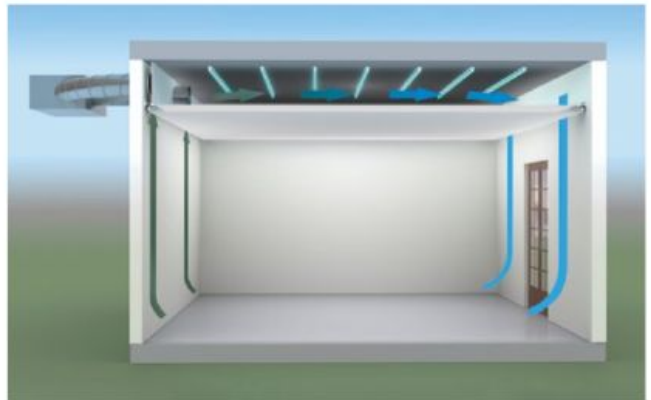

© Barrisol®

\* According to laboratory testings and simulation results

## BARRISOL CLOUD CLIM® FEATURING CARRIER® PRODUCTS

This hybrid panel uses diffusion and radiation principles to combine a high level of comfort, aesthetic, and versatility.



© Barrisol®



© Barrisol®

### Operation principle

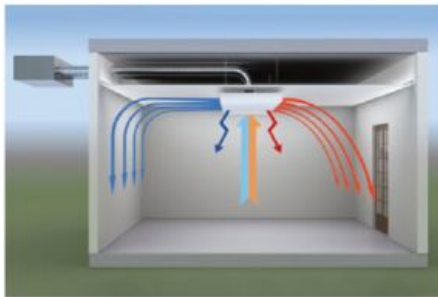

© Barrisol®

The system uses modules that are suspended from the ceiling, through which conditioned air is delivered into the room. Air can be fed into ceiling modules via a fan coil unit concealed nearby or located in a plenum.

The combination of convection and radiation makes it possible to achieve high heating/ cooling capacities whilst ensuring a homogeneous temperature.

Unlike conventional diffusers which blow the treated air at the same speed and angle, the system automatically adapts the diffusion flow according to the supplied air temperature. There is no draught thanks to the patented adaptive air flow principle.

### Flexibility & aesthetic

Available in three different formats\*, the solution offers unlimited possibilities of assembly and configuration with total freedom of customization: frame colours, vent designs, printed membrane, light, acoustic...



### 3 different formats

Mini Cloud Clim®

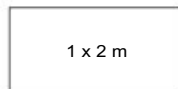

1 x 2 m

Cloud Clim®

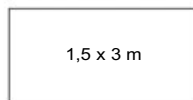

1,5 x 3 m

Maxi Cloud Clim®

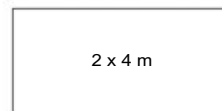

2 x 4 m

### Unlimited freedom of assembly

Example of a linear arrangement of Maxi Cloud Clim® - 3 Modules



Example of an adjoined arrangement Mini Cloud Clim® - 8 Modules



\* Customized format on request



## COMPATIBLE CARRIER® PRODUCTS\*

Carrier® products comply with the requirements of European Ecodesign regulations applicable to energy efficiency.

### Air handling units



39CP



39HX

### Ducted hydronic fan coils



42NH



42EP



42BJ



42GR

### VRF



38VT

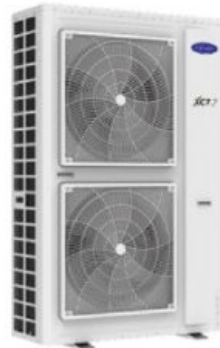

38VS



40VD\*L



40VD\*S



40VD\*H

### Split systems



42QSS



38QUS

\* products availability may vary depending on the countries





# Controls

1117

Type	Range	Page
<b>Control Solutions</b>		
	Smart Energy Monitoring	1119
	Plant Sequencer	1121
	Plant CTRL™	1127
	Fan coil controls overview	1129
	Thermostats	1131
	33TZ	1133
NEW	33ET	1137
	NTC controllers	1143
	WTC controllers	1147
	Aquasmart Evolution	1151
	Thermal Energy Storage system	1155



FOR CHILLERS & HEAT PUMPS



- CONNECTED SERVICES
- PERFORMANCE MONITORING
- TRACKING ENERGY CONSUMPTION
- IMPROVED EQUIPMENT AVAILABILITY
- FULLY SECURED ACCESS

# Smart Energy Monitoring

Optimize equipment operation & energy

The smart energy monitoring solutions, control and monitor in real time from one to several Carrier chillers and heat pumps. Compatible with all existing and new equipment, you benefit from the analysis of Carrier experts.

These solutions can be combined with both electrical and thermal metering options to track, monitor and optimize equipment performance and energy consumption.

## OPTIONS



Electrical metering



Thermal metering

- Information
- Alarms
- Preventive & corrective actions

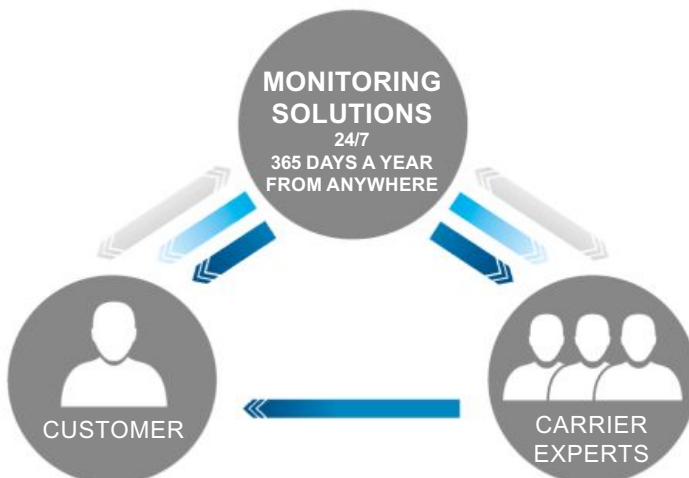

## MAIN FEATURES

- Site remote access (one or several units)
- Service access to pre-diagnose a remote fault
- Operating data storage and events
- Alerts / Alarms by mail
- Curve displays (customizable)
- Raw data extractions (customizable)
- Weekly, monthly, quarterly and yearly statistic reports
- Electrical metering option
- Thermal metering option
- Other options are available. For more information, please ask your Carrier sales representative.

## ELECTRICAL METERING / THERMAL METERING

Retrieve electrical & thermal data of the equipment on the smart energy monitoring solution to monitor & optimize electrical and thermal consumption (voltage, current, power, energy, etc.).

The metering hardware will be integrated into the electrical cabinet of the chiller. If the integration is not possible, a separated box is available in several references depending on the current range of the measured equipment.

Both meters comply with MID (Measuring Instruments Directive). Both electrical and thermal meters are also available in stand alone version:

- Collect electrical data (voltages, current, power, energy, etc.) for three phase power supply of one or several equipment
- Collect Thermal data (temperatures, flow, capacity & energy)
- Connect to a local BMS (LON FT-10, BACnet MS/TP, Modbus RTU)

## CAPACITY

- For all new and / or legacy chillers & heat pumps (from one to several)
- Communication with chiller or heat pump in CCN or BACnet protocols
- Communication with BMS through BACnet IP or Modbus TCP in option
- Electrical metering for three phase power supply of one or several equipment
- Thermal metering for one or several equipment
- Up to 150 operating data points recorded
- All customer parameters available

## PHYSICAL CHARACTERISTICS

### Electrical Metering

- Electrical counter
- 3 phases circuit breaker
- 3 static current transformers (openable in option)

### Thermal Metering

- Thermal counter
- 1 flowmeter
- 2 temperature sensors

### Monitoring solutions (box and integrated versions)

- 3G Modem + SIM card
- Metal box (only for box version)
- CCN gateway (only for box version)
- 230VAC -24VDC transformer (only for box version)
- Circuit breaker (only for box version)
- Antenna's power gain (5 m cable, only for box version)
- Terminal block (only for box version)

## SOLUTION ADVANTAGES

- Fully secured connection
- Minimizing maintenance and operating costs
- Understanding equipment operation
- Improving HVAC equipment availability
- Optimal control of equipment
- Managing energy expenses and consumptions
- Optimizing energy use & saving costs
- Meeting energy regulation criteria
- Benefit from our Carrier expertise through our service contracts



Reports, real-time data and alerts complemented by expert analysis





## TRUVU™ PLANT SEQUENCER



### HVAC SERVICE SOLUTION

Regulation, Control & Optimization of cooling and heating plants

# REGULATION, CONTROL & OPTIMIZATION OF COOLING AND HEATING PLANTS



The TruVu Plant Sequencer controls and optimizes cooling and heating plant rooms, benefiting from Carrier's expertise in HVAC systems.

**A turnkey solution**, with an advanced program, easily commissioned by Carrier service technicians.

**Energy savings** of cooling / heating plant.

**Reduced** operating and maintenance costs.

**Credit gains** for Leed®, Breeam®, Hqe™ certifications.

**Compliance** with local and european energy regulations.

## STANDARD CONTROL SOLUTION TO MANAGE AND OPTIMIZE COOLING & HEATING PLANTS

### Main capabilities

- Up to 4 Carrier chillers or heat pumps.
- Up to 2 secondary pumps.
- Up to 4 dry-coolers (version TruVu plant sequencer v2.0).
- 1 x 3-way valve (mutualized dry-coolers, version TruVu plant sequencer v3.0).

### Local monitoring

- 10" standard touchscreen with web server in the front of the electrical cabinet.

### Remote Communication

- BMS: BACnet/IP or Modbus TCP/IP.
- Optional Carrier i-Vu® remote monitoring solution.

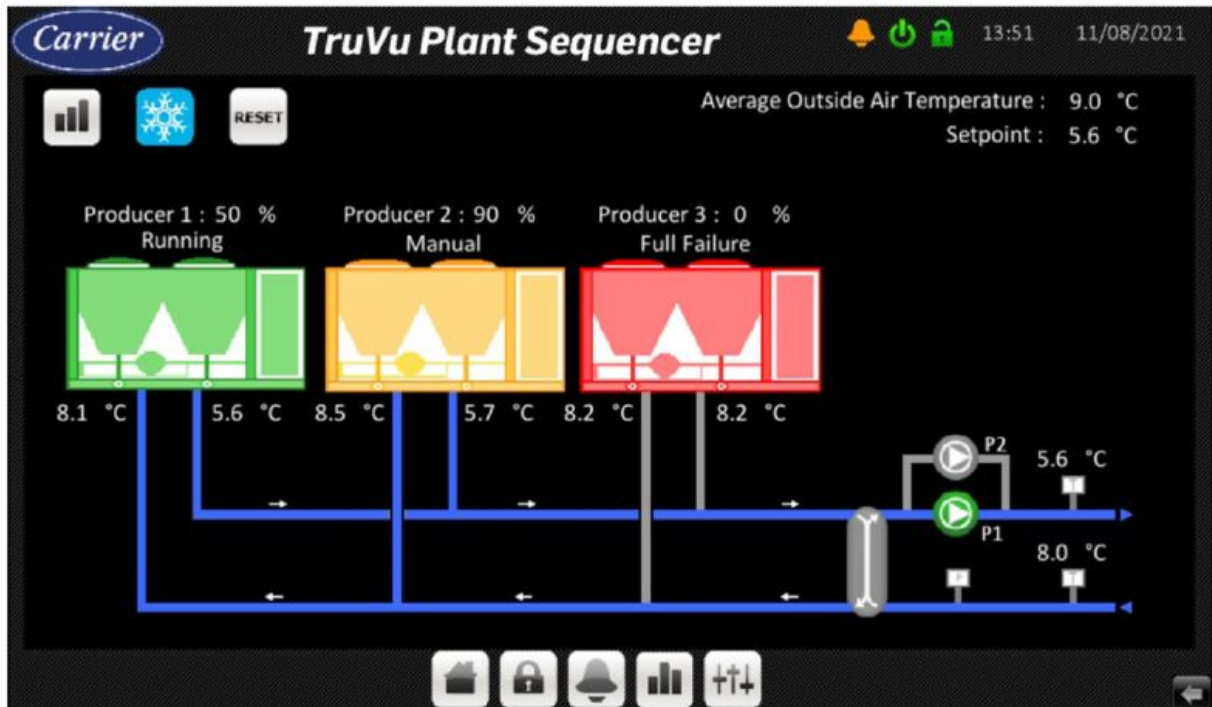

### Requirements

- BACnet/IP communication is compulsory with chillers or heat pumps.
- Evaporator pumps directly managed by the chiller or heat pump.
- Condenser pumps and 3-way valves for water-cooled units directly managed by the chiller or heat pump (version: TruVu plant sequencer v2.0).
- Modbus RTU communication compulsory with dry-coolers - optional Modbus RTU to physical I/O card (version: TruVu plant sequencer v2.0).
- No wired I/O except temperature and allowed components in the standard scope (see electrical diagram or technical data sheet).

## STANDARD CONTROL SOLUTION TO MANAGE AND OPTIMIZE COOLING & HEATING PLANTS

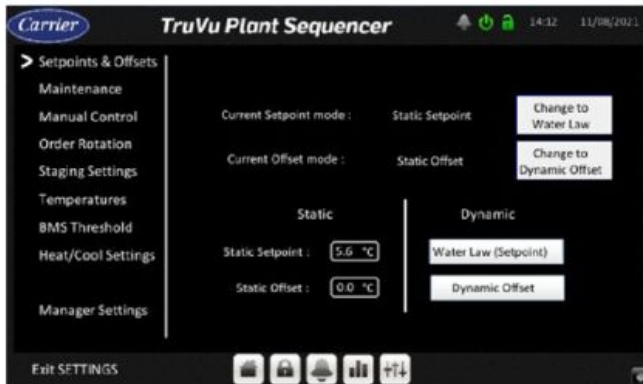

### Control Carrier chillers and heat pumps with BACnet IP option:

Cascade with time balance and alternation.  
 Faults, alarms and back up management.  
 Maintenance mode and manual operation.



### Dry-coolers:

Carrier & non-Carrier.  
 Setpoint configuration.  
 Faults, alarms and back up management.  
 Maintenance mode and manual operation.



### Secondary pumps:

Normal/rescue operation with time balance and alternation.  
 Fixed or variable flow with PID regulation on delta pressure.  
 Faults, alarms and back up management.  
 Maintenance mode and manual operation.

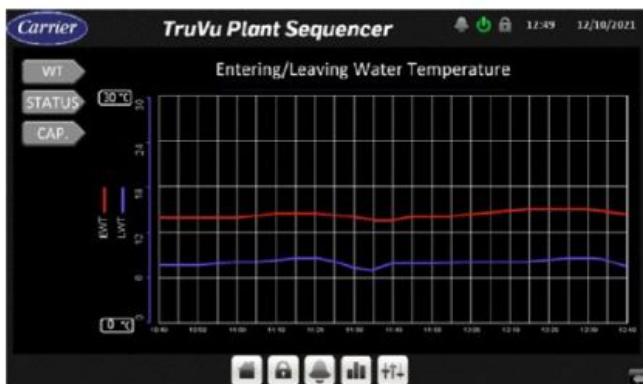

### Advanced cascade:

Automatic advanced cascade on temperature drift / temperature evolution / plant capacity / delta T°C.  
 Unit's cascade on full load or predefined partial load.  
 User setup (setpoints, setpoint offset units-network / mini-maxi running units, units priorities, etc.).



### Daily and seasonal programming:

Production start linked to BMS schedule.  
 Manual or automatic changeover for heating/cooling mode selection.



### Local Human to Machine Interface (HMI) and remote monitoring (option i-Vu):

HMI with Real-time synoptic / plant and components status / trends / events / secure access.  
 Webserver for remote visualization of the HMI.



### Energy savings:

Setpoint offset according to outside air temperature (user configurable).  
 Cascade staging up on predefined units partial load value (user configurable).



### Heat recovery and free-cooling:

(version: TruVu plant sequencer v2.0)

Priority given to units with the option enabled when conditions are met.  
 Setpoint management.



### BMS communication:

Communication table (read/write access) feedback of all the main operating parameters, faults, alarms.

## HYDRAULIC CONFIGURATION EXAMPLES

Air-cooled chillers/heat pumps with secondary pumps:

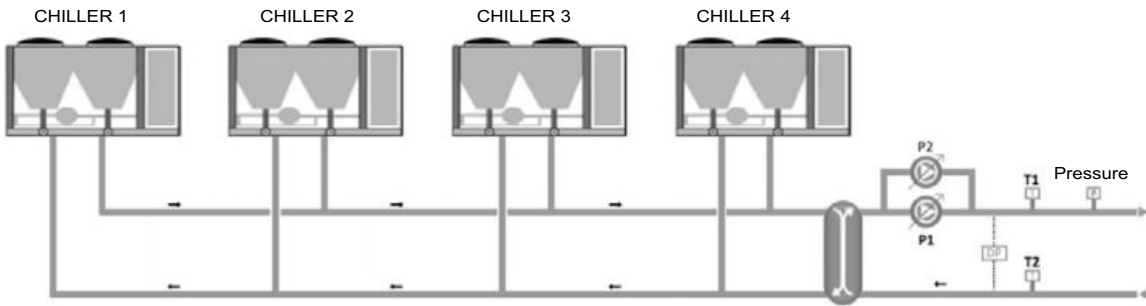

Water-cooled chillers/heat pumps with dedicated dry-coolers, and secondary pumps<sup>(1)</sup>:

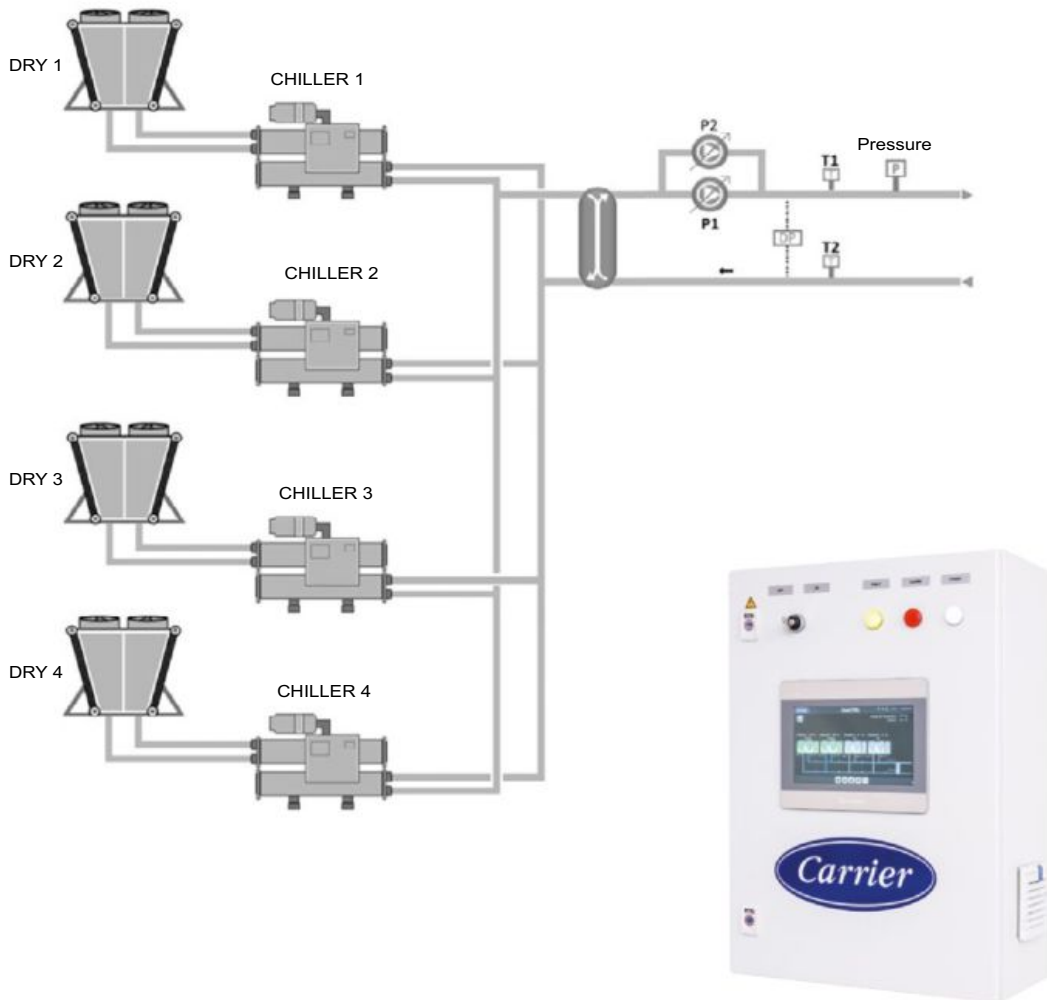

(1) Available for TruVu plant sequencer v2 or above.

## HYDRAULIC CONFIGURATION EXAMPLES

Water-cooled chillers/heat pumps with mutualized dry-coolers, and secondary pumps<sup>(2)</sup>:

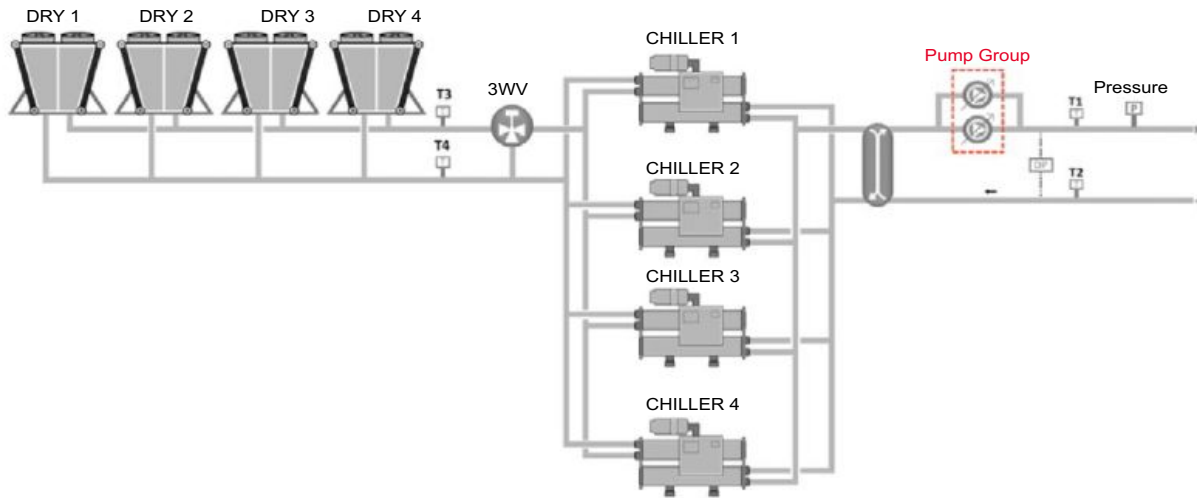

### ADDITIONNAL EQUIPMENT (not included)

- Pressure switch for lack of water detection.
- Delta P sensor for variable flow secondary pumps - 0/10 V.
- Modbus RTU for electrical meter - 1 on each chiller/heat pump or 1 common.
- Modbus RTU for flow meter or thermal meter - on leaving or return of network.

(2) Available for TruVu plant sequencer v3 or above.







FOR COOLING & HEATING PLANTS



- ADVANCED PLANT CONTROL
- OPERATION AND ENERGY CONSUMPTION OPTIMIZATION
- HIGH ADDED VALUE SOLUTION
- SECURED HEATING & COOLING PRODUCTION
- QUICK RETURN ON INVESTMENT
- COMPLYING WITH ENERGY REGULATIONS & BUILDING CERTIFICATIONS

# PlantCTRL™

Management & monitoring system

The PlantCTRL™ regulates and controls all Carrier thermal production plants operation. This system is compatible with all existing and new Carrier equipment from two to several chillers and / or heat pumps.

Available for all applications, this system is able to manage all cooling & heating production components and all associated hydraulic devices: Chillers, heat pumps, cooling towers, dry coolers, energy metering, valves and pumps.

## OPTIONS



User interface



Remote monitoring

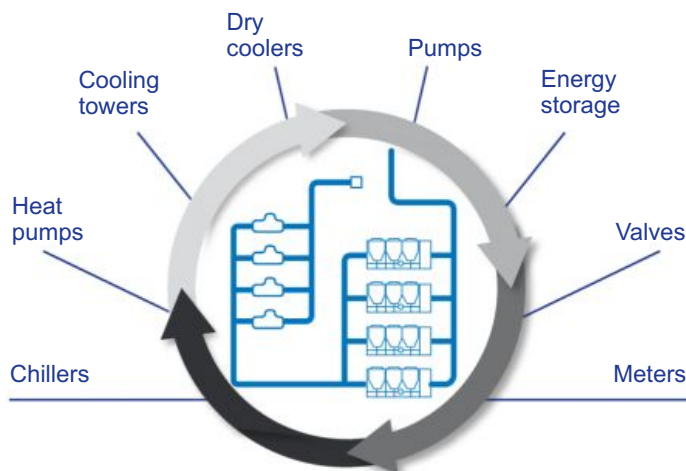

PlantCTRL™

## MAIN FEATURES

### Command & control your HVAC plant

- Production and operation strategy management
- Controlling and monitoring of chillers and heat pumps, dry coolers and cooling towers depending on the operation needed
- Controlling and monitoring of all hydraulic components of the installation (valves, pumps, frequency convectors,...)

### Manage the energy

- Daily and seasonal programming
- Optimization of the chillers, heat pumps and hydraulic components cascading management
- Set-points configuration and optimization
- Energy management of the system (free cooling, energy recovery and other sources)

### Secure the operation

- Faults / alarms detection and signaling, corrective management algorithms
- Equipment management alternation / rescue /priority network
- Preventive maintenance alerts scheduling
- View of the installation and equipment states

### Monitor the installation

- On site local monitoring and remote monitoring through the dedicated Website
- View in real time of the equipment and installation states, access to installation synoptics, operation curves
- Events notification by mail (faults / alarms)
- Long-term saving of recorded values, events & curves

## CAPACITY

- Management of the chillers, heat pumps, dry coolers, cooling towers, pumps and valves
- Energy metering, flowmeters, temperature sensors and pressures
- Energy recovery and free cooling
- Coupling with other energy sources (EnR, boilers, geothermal,...)
- Communication with all BMS
- Other communication by open protocols and non Carrier equipment (BACnet IP, MS/TP, Modbus TCP / IP, Modbus RTU and LonWorks,...)

## PHYSICAL CHARACTERISTICS

- Available in box version for both new and existing equipment (an integrated option for electrical cabinet is available)
- Dimensions and weights according to configuration and options
- IP54 steel enclosure
- Enclosure power supply: 100-230 VAC, 50 / 60Hz
- Operating temperature range: -10 °C to +50 °C
- Humidity: 0 to 90% RH, non-condensing
- Storage: -20 °C to +60 °C, 0 to 90% RH, non-condensing

## USER INTERFACE



## / REMOTE MONITORING



## OPTIONS

It is possible to monitor the installation locally from the user interface of the PlantCTRL™ box or from a PC.

You have also the possibility to monitor the installation remotely from a PC/tablet with internet access. The PlantCTRL also communicates with the BMS.

The three monitoring options provide access to all equipment operating parameters in real time:

- Installation synoptics
- Operating curves
- Schedule programming
- Event reports
- Components states
- Recorded data

## SOLUTION ADVANTAGES

### Expert in plant management:

- System and control expertise
- Commissioning and installation support
- One supplier to facilitate the installation
- Ergonomic and easy friendly user interface
- Optimized operation sequencer

### Flexible and scalable solution:

- Tailor-made solution for existing and new plants
- Suitable to process & comfort applications
- Compliance with all BMS
- Fully configurable according to building evolutions
- 24/7 plant monitoring

### Costs management and profitability:

- Real-time operating and maintenance costs management
- Quick Return On Investment
- Carrier service experts support

### Secured installation:

- Maximize equipment lifetime
- Improve equipment efficiency
- Secure the plant operation
- Facilitate better production availability

### Energy optimization:

- Manage energy consumption
- Energy optimization during the lifetime of the installation
- Preventive maintenance to ensure the durability of equipment

### Comply with energy regulations:

- LEED, BREEAM and HQE credits
- Value of sustainable energy solutions (free cooling, energy recovery,...)
- Contribute to develop energy efficiency of buildings (local and European regulations)

**FAN COIL CONTROLS OVERVIEW**

	33TZ Thermostat	Thermostat	NTC controllers	WTC controllers
<b>Communication Protocols</b>				
Carrier Communication Network (CCN) Aquasmart compatible			x	
BACnet				x
LON				x
<b>Control algorithms</b>				
On-off	x	x		
Proportional-integral			x	x
Carrier Energy saving algorithm			x	x
<b>Fan control</b>				
AC motors 3 speeds descreet	x	Type A&B	x	x
Automatic optimum fan speed selection		x	x	x
EC motors 3 speeds descreet	see 33TZ section	Type C&D	x	x
EC motors Variable speed			x	x
<b>Water Valve management</b>				
Air flow control only (no water valve)	x	x		
On-off actuators	x	x	x	x
Modulating actuators (3pts or 0-10V)			x	x
<b>Main functions</b>				
Set-point control	x	x	x	x
Occupied/unoccupied mode	x	x	x	x
Frost protection mode	x	x	x	x
Window / Door contact input	x	x	x	x
Measurement of water inlet temperature for automatic seasonal changeover (2 pipes)	only 2p & 2p+elec heater	Type A&C	x	x
Automatic seasonal changeover (4 pipes and 2 pipes + electric heater)	only 2p & 2p +elec heater	Type D&B	x	x
Manual changeover		x	x	x
Frost protection mode	x	x	x	x
Continuous ventilation within dead-band	x	x	x	x
Periodical ventilation within dead-band	x	x	x	x
On-site configuration	x	x	x	x
Unit grouping Master/Slave		x	x	x
Cassette Louvers control			x	x
Supply air temperature monitoring limiting			x	x
Electrical heater loadshed			x	x
Dirty filter alarm			x	x
Alarm reporting			x	x
Indoor Air Quality control (CO <sub>2</sub> sensor)			o	o
Demand control ventilation (DCV) (0-10V fresh air valve)			o	o
Free cooling mode				o
Presence detection				o

**Legend**

- x feature available as standard
- o optional

FAN COIL CONTROLS OVERVIEW



	33TZ Thermostat	Thermostat	NTC controllers	WTC controllers
<b>User interfaces</b>				
Automatic or manual fan speed control	x	x	x	x
Operating mode selection	x	x	x	x
Occupancy (eco) button		x	x	x
Digital display			o	o
Remote control (infra-red)			o	o
CO <sub>2</sub> sensor			o	o
Light sensor				o
Presence sensor				o
Easy connection RJ45 jack (on wall mounted UI)				x
<b>Light &amp; Blinds management</b>				
Light power modules				o
Blinds power modules				o
<b>Control kit</b>				
On site control kit solution				o

**Legend**  
 x feature available as standard  
 o optional



## CONTROL SOLUTIONS



# Thermostats

Carrier electronic thermostat range is available for all Carrier hydraulic terminal ranges:

- Type A - Two-pipe application with AC motors
- Type B - Four-pipe or two-pipe applications with electric heaters with AC motors
- Type C - Two-pipe application with EC motors
- Type D - Four-pipe or two-pipe applications with electric heaters with EC motors

The thermostat for fan coil units with EC motor option controls three configurable discrete speeds via an 0-10 V signal.

The electronic thermostat set range is from 10°C to 30°C, with the possibility to limit the temperature in public buildings where low energy consumption is a key requirement. This is done via a dip-switch inside the control (cooling range 23°C/30°C, heating range 10°C/21°C).

## FEATURES AND ADVANTAGES

- Auto fan: the control automatically sets the fan speed. If the room temperature is far from the set-point, high fan speed is selected. As the room temperature approaches the desired value, the fan speed decreases to the minimum speed.
- Automatic changeover from cooling to heating mode, based on the water temperature, ensures that the ideal room temperature is maintained.
- Remote changeover - automatic changeover from cooling to heating mode, based on the remote signal from the monitoring system.
- Frost protection keeps the room temperature above a minimum level.
- Booster heating control optimisation (with electric heater option): with the water temperature below 30°C the system will be in heat demand mode and the electric heater is the only available heating source. If the water temperature is above 35°C the system will be in booster heating mode, energising water valve and electric heater together. This function is deactivated if the water temperature is above 45°C (the electric heater will be de-energised).
- Energy saving when the room is unoccupied, without the need to switch off the unit. If the energy-saving button is pressed, the actual set-point will be modified as follows, without changing the position of the set-point selection knob:  $\pm 4$  K.
- LED intensity (offices or light commercial applications) - 10 seconds after the last user interface use all LEDs are reduced in intensity. To avoid disturbing hotel guests, the thermostat can be configured from "Night Mode" to "Dark Mode": 10 seconds after the last user interface use, all LEDs are switched off.
- Air sampling: with no fan request and the air sampling jumper in ON position, the control performs the air sampling function. The air in the room is moved, thermal stratification is reduced for a more reliable ambient temperature reading.
- Continuous fan (no fan request and continuous fan jumper ON): the control selects the fan speed, regardless of thermal station conditions. With fan in auto fan mode and control not in the demand phase, the fan permanently runs at low speed.
- External contact: A high voltage input signal for external contact is present. If the contact is activated, device behaviour depends on its configuration on site:
  - Presence detection energy saving mode is activated, room temperature is raised by 4 K in cooling mode and reduced by 4 K in heating mode.
  - Window contact: in OFF mode (window open), all outputs are disconnected (fan, valves, etc.) and only the frost protection function is active, if enabled.

## ELECTRONIC ON/OFF AIR OR WATER CONTROL SYSTEM



Factory-recessed thermostat

Customised performance  
with a low cost solution

# 33TZ

The 33TZ control system is a specific Carrier control system with an innovative design, dedicated to fan coil units, and developed using our expertise.

The 33TZ control system is a Carrier electronic control system devised to control a non-independent air handling terminal unit (ductable, cassette-type fan coil units...) for applications using 2 tubes, 2 tubes/2 wires, 4 tubes with recirculated air.

There are two types of 33TZ controls:

- Air control types, which act on the ventilation. This application has its drawbacks when used with vertical devices: the coil continually supplies cold water or hot water, which creates an incorrect temperature reading at the intake.
- Water control types, which act on two-way valves or four-way valves with a 230 V electrothermic motor and ventilation (recommended to ensure comfort levels).

The 33TZ control is available in a built-in version factory-fitted in a fan coil unit to be mounted under a sill, or a wall-mounted version to be connected by the installer.

## DESCRIPTION

The 33TZ control is an on/off type control, which can be configured for the chosen application on site using 8 switches. It has a potentiometer for setting the required temperature, which can be adjusted across a range of +/- 6 °C.

The wall-mounted version is available with a potentiometer graduated in degrees.

Two temperature setpoints: heating (19 °C) and cooling (factory-set at 25 °C).

The cooling setpoint can be configured on-site (25 °C or 23 °C).

The 33TZ has a selector to actuate three manual ventilation speeds.

The operating statuses of the thermostat are displayed using 3 LEDs: comfort/heating/cooling on.

The changeover is managed automatically by the thermostat via a water temperature sensor or via a signal from an external dry contact.

When heating or cooling is requested, the fan is triggered automatically at the speed selected by the user.

The 33TZ controls the heating via the electric heater in time-proportional mode, according to the ventilation speed selected, to prevent the comfort unit overheating.

The thermostat manages the fan delays required for unit shut down.

If the selector is in the off position, the thermostat keeps the room in which it is installed frost-free at a setpoint of 8 °C.

A dry contact input, which can be configured on-site, enables the thermostat to be automatically switched to economy mode (automatic shift of +/- 5 °C in the heating and cooling setpoints) or frost protection mode (heating setpoint +8 °C).

See our instruction manual for more detailed information.



## 33TZ CONTROL ON AIR (WITHOUT VALVE)

		42NC/NR ND vertical installation	42NC/NR/ND/ NI/NU	42KY	42GW / 42NH/ NL
<b>CONTROL UNIT</b> On/Off electronic controller Thermostat with potentiometer Wall-mounted or built-in version (without isolating switch) Without valve Return air sensor (for built-in version) Fittings not included		Configuration in the POD	Configuration in the POD	For AC or EC motor	For AC motor only
<b>AIR CONTROL (without valve, not recommended for vertical units*)</b>					
<b>2-pipe system</b>					
- Heating only (or heating/cooling selection using external contact)		digit 9 = "V"	digit 9 = "W"	wall version	wall version
- Cooling only (or heating/cooling selection using external contact)					
- Automatic heating/cooling with changeover sensor (supplied separately on wall-mounted units)		digit 9 = "V" & digit 14 = "B"	digit 9 = "W" & digit 14 = "B"	wall version + change over sensor	wall version + change over sensor
<b>2-pipe system + 2000 W max. electric heater</b>					
- Cooling + electric heater		digit 9 = "V"	digit 9 = "W"	wall version	wall version
Heating/cooling + electric *with temperature sensor supplied as a kit		digit 9 = "V" & digit 14 = "B"	digit 9 = "W" & digit 14 = "B"	wall version + change over sensor	wall version + change over sensor
Surcharge for power levels of over 2000 W and up to 4600 W		Standard in the unit	Standard in the unit	On request	On request
<b>OPTIONS and ACCESSORIES</b>					
	Return air temperature sensor for wall thermostat, supplied as a kit or change over sensor	<b>L = 2,5 m</b>			

\* **Note regarding 42NC/NR/ND vertical units fitted with 33TZ built-in** : the heat continuously radiated on the sensor by the heat exchange coil will prevent the control system from operating correctly. It is the customer's responsibility to place the sensor at the best location that will ensure that the units operate correctly.

PRESENTATION  
COOLING  
HEATING  
AIR TREATMENT  
CONTROLS

## 33TZ CONTROL WITH VALVE

		42NC/NR ND vertical installation	42NC/NR/ND/ NI/NU	42KY	42GW / 42NH/ NL
<b>CONTROL UNIT</b> On/Off electronic controller Thermostat with potentiometer Wall-mounted or built-in version (without isolating switch) Without valve Return air sensor (for built-in version) Fittings not included		Built version 33TZ	Configuration in the POD	For AC or EC motor	For AC motor only
<b>2-pipe system</b>					
<b>Heating only or cooling only</b>					
With 2 ways valve ON/OFF 230V		digit 9 = "V" & digit 10&12= GA	digit 9 = "W" & digit 10&12= GA	wall version	wall version
With 4 ways valve ON/OFF 230V		digit 9 = "V" & digit 10&12= HA	digit 9 = "W" & digit 10&12= HA		
<b>Automatic heating/cooling with changeover sensor</b> (supplied separately on wall-mounted units)					
With 4 ways valve ON/OFF 230V		digit 9 = "V" & digit 10&12= HA & digit 14 = "B"	digit 9 = "W" & digit 10&12= HA & digit 14 = "B"	wall version + change over sensor	wall version + change over sensor
<b>2-pipe system + 2000 W max. electric heater</b>					
<b>Cooling only + electric heater</b>					
With 2 ways valve ON/OFF 230V		digit 9 = "V" & digit 10&12= GA	digit 9 = "W" & digit 10&12= GA	wall version	wall version
With 4 ways valve ON/OFF 230V		digit 9 = "V" & digit 10&12= HA	digit 9 = "W" & digit 10&12= HA		
<b>Automatic heating/cooling +electrical heater with changeover sensor</b> (supplied separately on wall-mounted units)					
With 4 ways valve ON/OFF 230V		digit 9 = "V" & digit 10&12= HA & digit 14 = "B"	digit 9 = "W" & digit 10&12= HA & digit 14 = "B"	wall version + change over sensor	wall version + change over sensor
Surcharge for power levels of over 2000 W and up to 4600 W		included	included	On request	On request
<b>4-pipe system</b>					
With 2 ways valve ON/OFF 230V		digit 9 = "V" & digit 10&12= GA	digit 9 = "W" & digit 10&12= GA	Wall version	Wall version
With 4 ways valve ON/OFF 230V		digit 9 = "V" & digit 10&12= HA	digit 9 = "W" & digit 10&12= HA		
<b>OPTIONS and ACCESSORIES</b>					
	Return air temperature sensor for wall thermostat, supplied as a kit or change_over sensor	<b>L = 2,5 m</b>			





**NEW**

## ELECTRONIC AIR OR WATER MANAGEMENT SYSTEM



# 33ET

The 33ET electronic thermostat is designed to actuate fan coil units, for 2- or 4-tube applications with an AC or EC motor operating with recirculated air (4 different thermostats).

The 33ET electronic thermostat operates with water control which acts on the 230 V on/off thermo motor valves and on the ventilation with either:

- A 230 V 3-speed AC motor.
- A 0 -10 V 3-speed EC motor.

The thermostat is designed for flush-mounted installation using screws in a standard 60 mm box.

### Description:

- Manual or automatic heating/cooling switching.
- Four modes: Comfort/Economy/Frost protection/Off.
- 230 V power input
- Control of a manual or automatic 3-speed fan.

42NC/NR  
ND/42NH/NL/42KY  
42GR/42GW/42EP/42BJ



Water control

2-tube system, AC motor

Hot water valve only	33ET A 7615572
Cold water valve only	
Automatic hot/cold water valve with or without changeover sensor	

4-tube system, AC motor

One hot water valve + one cold water valve	33ET B 7615573
--	-------------------

2-tube system, EC motor

Hot water valve only	33ET C 7615574
Cold water valve only	
Hot/cold water valve with or without changeover sensor	

4-tube system, EC motor

One hot water valve + one cold water valve	33ET D 7615575
--	-------------------

Option and accessories



Sensor with faston terminal, to be removed for screw terminals

Changeover sensor

7209243

# INSTALLATION INSTRUCTIONS

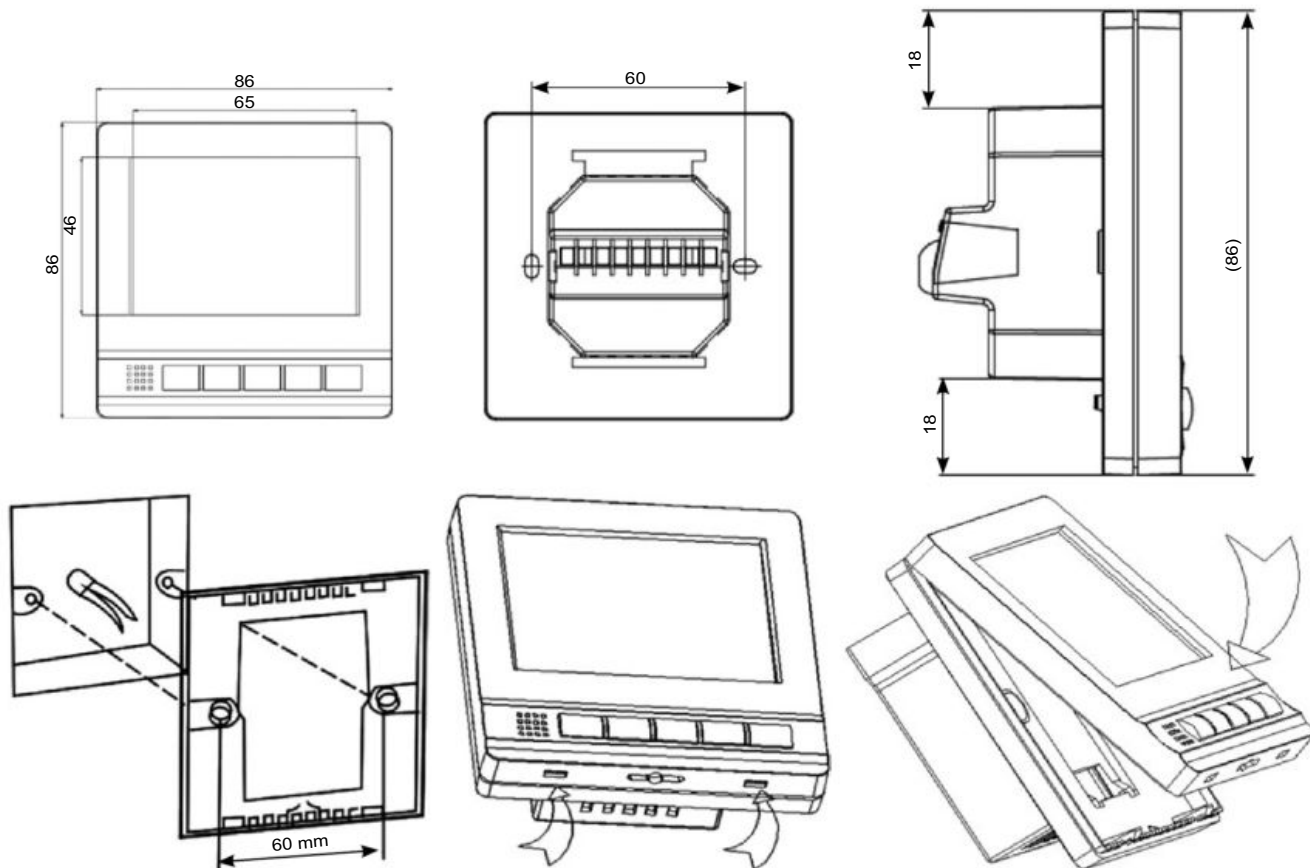

Dimensions in mm

<b>Power supply</b>	230 V 50/60 Hz	<b>Internal sensor</b>	NTC 10K, 3950K at 25 °C
<b>Consumption</b>	<1 W	<b>CO sensor (2P)</b>	NTC 10K 3977K at 25 °C
<b>Maximum current for 230 V relays</b>	5 A	<b>Temperature measurement range</b>	0~50 °C
<b>Setpoint setting range</b>	5 °C to 35 °C	<b>Accuracy</b>	± 1 °C (adjustment intervals of 0,5 °C)
<b>Maximum cable cross-section</b>	2,5 mm <sup>2</sup>	<b>Relative humidity</b>	85 %
<b>Stripped length</b>	6 mm	<b>IP protection</b>	IP30
<b>Tightening torque</b>	0,4 N.m	<b>Housing</b>	ABS, UL94-5
<b>Electrical protection class</b>	Class 2	<b>Min./max. cable cross-section</b>	1 - 2,5 mm <sup>2</sup>

# INSTALLATION INSTRUCTIONS

## Electrical connection

### 2T-AC WALL THERMOSTAT

2 TUBES

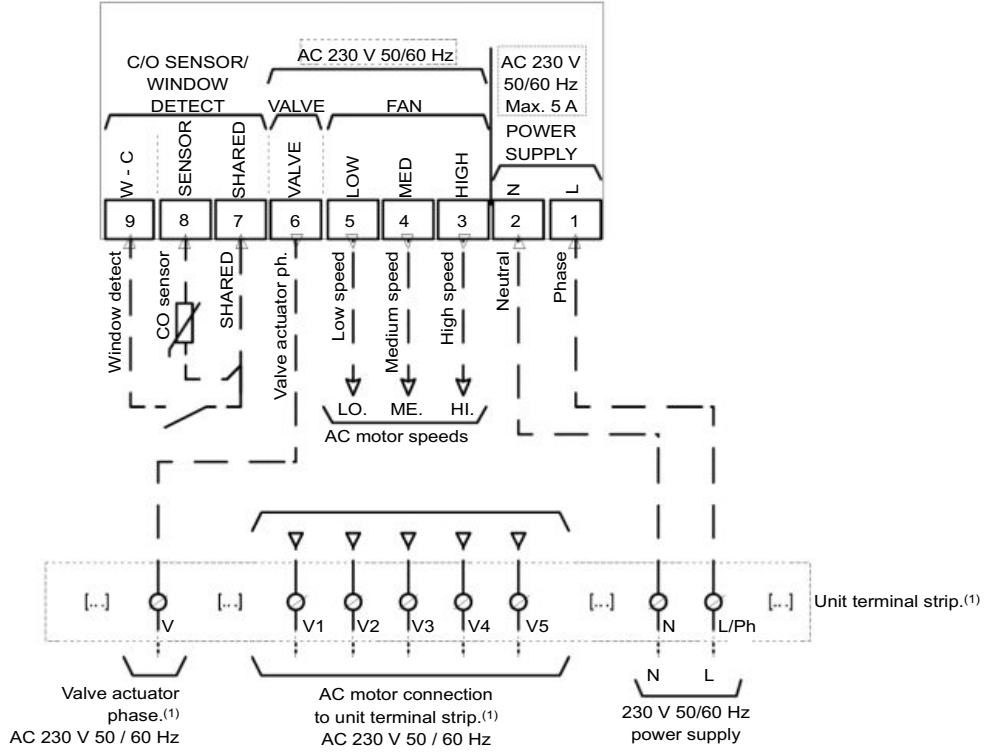

### 4T-AC WALL THERMOSTAT

4 PIPES

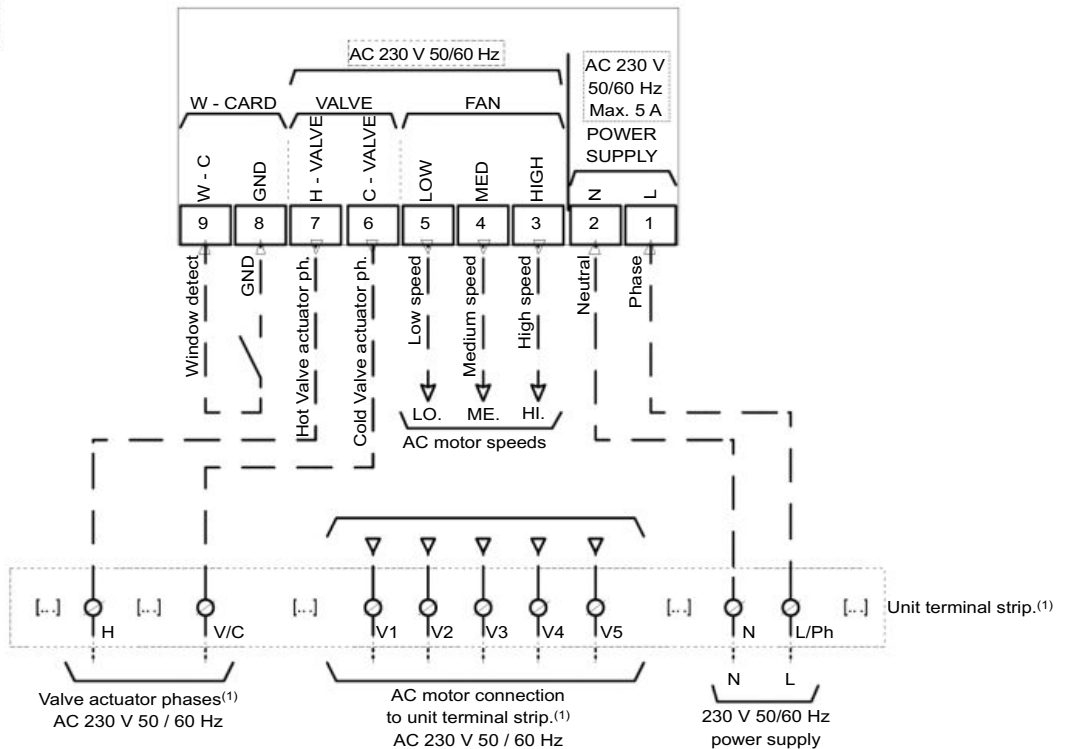

(1) See unit wiring diagram



# INSTALLATION INSTRUCTIONS

## 2T-EC WALL THERMOSTAT

2 TUBES

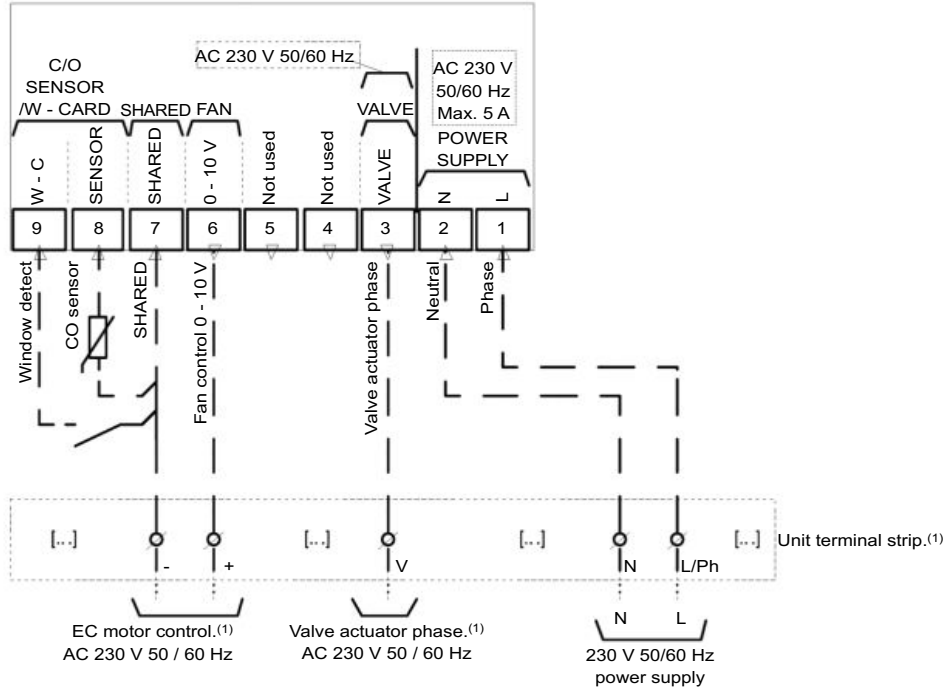

## 4T-EC WALL THERMOSTAT

4 PIPES

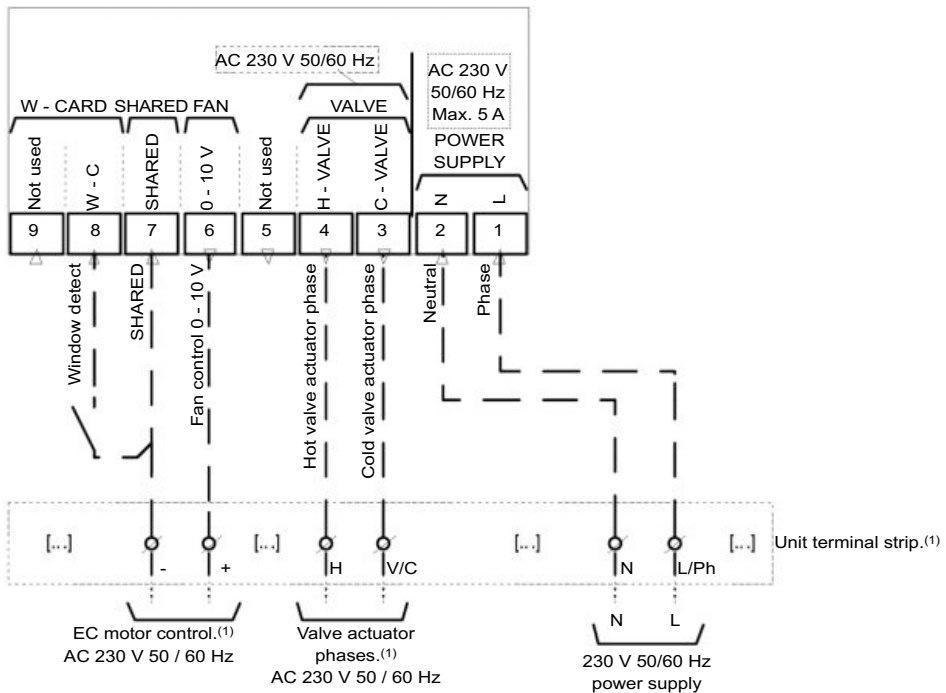

(1) See unit wiring diagram



## CONTROL SOLUTIONS



# NTC controllers

Carrier offers one of the market's most sophisticated and complete communicating controllers for hydraulic fan coil ranges, the NTC controller, that is compatible with the full Carrier fan coil range.

For the customer and installer the same controller simplifies and eases installation and service operations whilst covering a wide range of hydraulic system types and applications.

The controller can be applied and function as either a standalone control, as part of a larger CCN system application, or at the heart of a Aquasmart system functioning with the Aquasmart Touch Pilot System Manager.



## NETWORK COMMUNICATION

- The NTC communicating controller can be connected on an RS 485 bus, using the Carrier Comfort Network (CCN) protocol.
- Units equipped with the NTC controller can be part of the Aquasmart Evolution system.

## ADVANCED FUNCTIONS

- Low Energy Consumption (LEC) variable speed control.
- The NTC controller can drive the fan speed continuously within a configurable range for optimal thermal and acoustic comfort.
- Hydraulic control - The NTC controls both floating and fixed-point value actuator types (230 V on-off and 230 V three point).
- Demand controller ventilation (DCV) - On fan coils equipped with CO<sub>2</sub> sensors and fresh air dampers, the NTC controller can adjust the amount of fresh air admitted to the room, as required by the occupants.
- IAQ management - The NTC controller can control all features related to Indoor Air Quality that are included in Carrier terminal fan coil units.

### Carrier Room Controller (CRC2)



### Simplified User Interface (SUI)



### Infrared Remote Control (IR2) and receiver

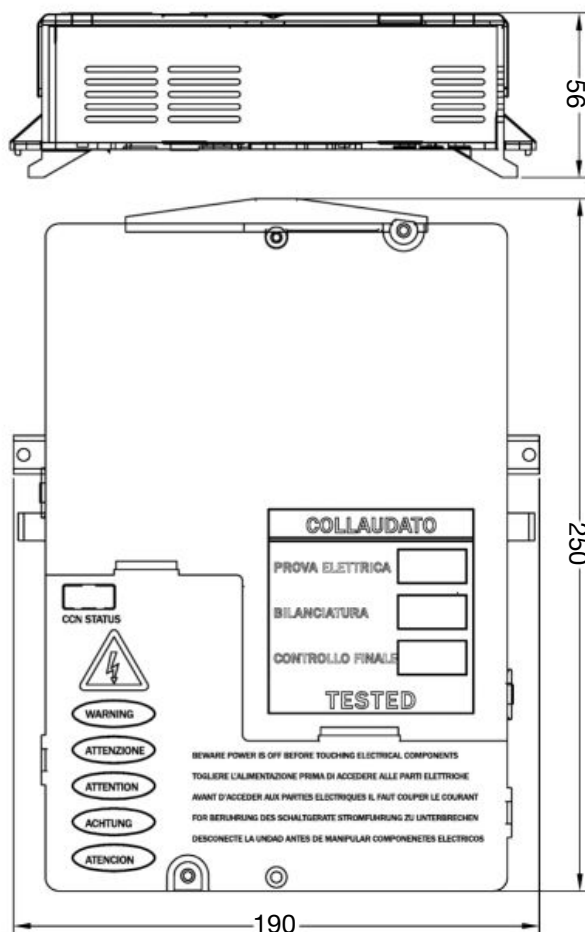

## ADVANCED FUNCTIONS

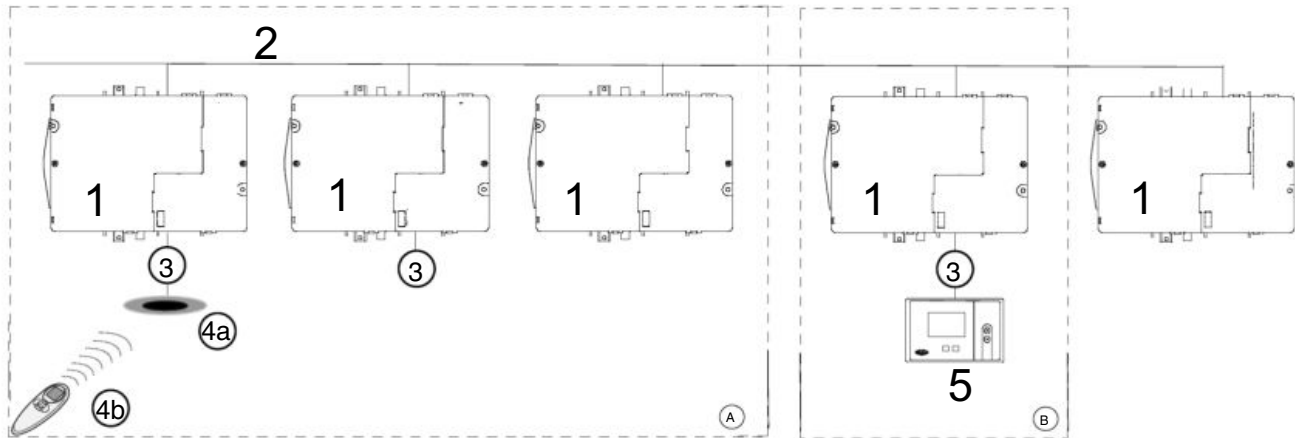

**Legend**

- 1 NTC controller
- 2 Secondary communication bus
- 3 User interface connection
- 4 IR2
- 5 CRC2
- A Room A
- B Room B

## FEATURES AND ADVANTAGES

- The NTC controller controls and optimises the operation of hydraulic terminal fan coil units. It is a microprocessor-based CCN (Carrier Comfort Network) compatible communicating controller with energy-saving algorithms.
- Energy-saving algorithms manage water valve operation and fan speed control simultaneously to ensure minimum energy consumption whilst maximising comfort conditions for the occupant.
- Factory-installed on terminal fan coils  
The NTC controller is factory-installed on the terminal fan coil; the assembly is also factory-tested. As a result, field installation is extremely simple.

- A wide range of user interfaces  
Depending on the application, two user interface types can be selected:
  - A simplified wired analogue user interface (SUI) that can be wall-mounted
  - A wired communicating user interface (CRC2) that can be wall-mounted.
  - An infrared user interface (IR2) for use together with a wall-mounted infrared receiver or a receiver incorporated on compatible terminal fan coils (42GW)





## CONTROL SOLUTIONS



# WTC Controllers

With Carrier's specific control algorithms, the Water Terminal Controller (WTC) combines best-in-class comfort solutions together with high energy efficiency management.

Designed for a variety of configurations and offered in a wide range of user interfaces, the WTC can fit every application and every need.

## CONTROL ARCHITECTURE

### A variety of configurations for every application

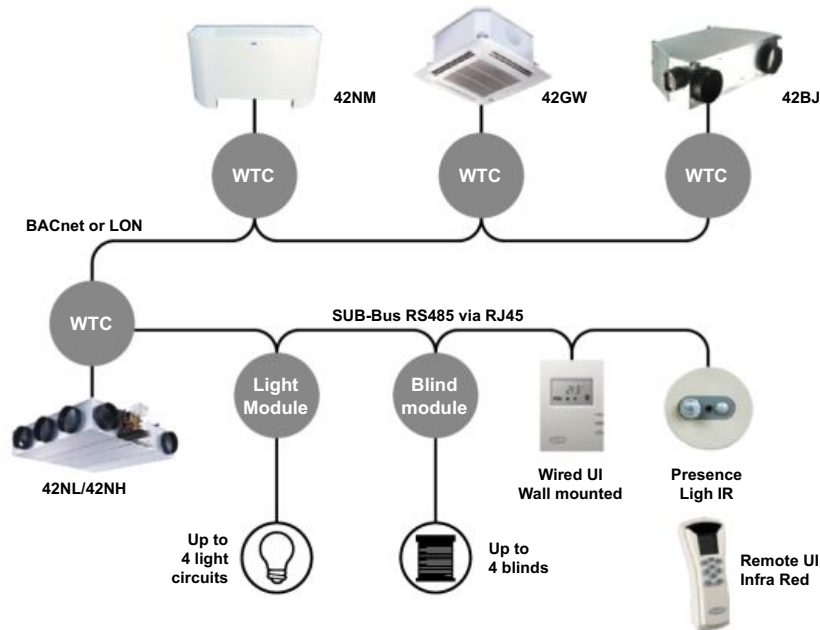

## FEATURES AND ADVANTAGES

- **High efficiency:** The WTC's energy saving algorithms control fan speed and manage water operation in parallel achieving optimal energy consumption whilst ensuring there is no resulting loss in comfort for occupants.
- **Easy installation:** The WTC is compatible with the full Carrier fan coil range. For customers and installers the same controller simplifies and eases installation and service operations whilst covering a wide range of hydraulic system types and applications. The WTC is factory installed on the terminal fan coil before factory testing of each individual terminal. As result, field installation is extremely simple.
- **Variety of configurations:** The controller can operate as either a standalone control, command and follow function for open spaces, or at the heart of a building management system.
- **User friendly user interface:** The user interface is available in a variety of configurations: no display, LCD display, temprature sensor, lights and blind control, etc.

## ADVANCED FUNCTIONS

- **Low Energy Consumption (LEC) variable speed control:** The WTC can drive the fan speed continuously within a configurable range for optimal thermal and acoustic comfort.
- **Modulating hydraulic control:** The WTC controls both floating and fixed-point value actuator types (230V on-off and 230V three point).
- **Demand controller ventilation (DCV) & IAQ management:** on fan coils equipped with CO<sub>2</sub> sensors and fresh air dampers, the WTC can adjust the amount of fresh air admitted to the room, as required by the occupants.
- **Lights and blind management modules:** The WTC supervises the interconnection of light modules & blinds modules, allowing the user to improve local comfort control with the same user interface as HVAC system.

## ROOM CONTROLLER - USER INTERFACE

Large choice of Room Controllers



Infrared Remote Control and receivers



HVAC



HVAC + lights/Blinds



A range of user interfaces to meet all needs

	Room Control Interface			Infrared Remote Interface	
	WTC-RCI-S	WTC-RCI-SF/SQF	WTC-RCI-D/DC/DM/DCM	WTC-IR	TC-IR-LB
Temperature sensor	✓	✓	✓		
Set-point offset		✓	✓	✓	✓
Fan speed	✓	✓	✓	✓	✓
With or without occupancy function		✓	✓	✓	✓
Operating mode		✓	✓	✓	✓
Light & blind control			✓		✓
Power supply from WTC	✓	✓	✓		
Quick connection	RJ45	RJ45	RJ45		
Local service tool			✓		
With or without motion sensor			✓		
LCS display			✓	✓	✓
Infrared receiver with status (LED & BUZZER)				✓	
Infrared receiver					✓





## CONTROL SOLUTIONS



# Aquasmart



Aquasmart Evolution is a complete hydraulic heating, ventilating and air conditioning (HVAC) system ideal for residential and light commercial applications from offices, commerce to hotels and hospitals. It offers perfect comfort for building occupants whilst optimising economical operation for applications up to 2500 m<sup>2</sup>. Larger installations with multiple systems can be managed and integrated within a single Building Management solution thanks to the new BACnet option capability.

An Aquasmart system consists of up to 128 terminal fan coil units, served by up to two chillers or heat pumps (master-slave), to supply cooling and/or heating to occupied spaces and fresh air handling units. The system manager can fully integrate and control up to eight Carrier fresh air handling units\*. Each fresh air plant can be associated with specific terminal fan coils and/or zones for optimum building use management with occupancy, controlling and minimising energy use.

Individual schedules can be set up and managed for each and all air treatment plants. The Aquasmart System Manager supplies building information enabling dynamic and precise control of the air handling units\* night-time free-cooling feature to further reduce building energy consumption.

\* If air treatment unit is not supplied by Carrier, integration is limited to control via a digital output for the main fresh-air unit.

## FEATURES AND ADVANTAGES

- The Aquasmart Evolution system ensures significant energy savings combined with optimised user comfort by managing building zoning, occupancy and room temperatures in accordance with needs.
- Terminal fan coil units can be organised in up to 32 zones to optimise building management by zone requirement and according to building design conditions.
- The Touch Pilot System Manager – the brain and building user interface was designed to facilitate use and allow rapid access to manage and configure system operation to maximise energy savings at comfort conditions.
- System components are fitted with communicating controls allowing the System Manager to communicate with and obtain feedback on user needs and operation. Based on the system requirements the System Manager coordinates the system heating and cooling modes for maximum comfort and optimal energy consumption, respecting the comfort parameters and occupancy schedules for the building zones.
- The Aquasmart system offers affordable building HVAC system management featuring capabilities usually only available in more expensive solutions and requiring additional building-by-building programming development.

### System design layout and configuration guide

- The System Manager is connected to the system components via a communication bus, and allows control of all system and individual terminal operating parameters.
- System configuration is simple through easily accessible menus. Unit grouping is managed by the network and requires no specific wiring to allow easy reconfiguration to suit later building layout modifications.
- The Aquasmart Evolution components are delivered complete, configured and factory-tested.

### Energy savings

- The Aquasmart system controls offer superior comfort levels. By optimising and controlling the system components building owners and occupants can save energy and reduce their energy bill, contributing to a reduction in building carbon emissions.
- System control saving possibilities are further enhanced with a range of significant energy-saving features available at equipment level, such as air handling unit with heat recovery technology, the use of reversible 30RQ air-to-water heat pumps for space heating, 61AF heat pumps for domestic hot water and a range of fan coil units with EC motor technology and variable fan speed control.
- Energy simulations conducted with a recognised software simulation program indicate that Aquasmart can achieve energy savings over a traditional non-communicating and non-optimised system. Case studies indicate that savings of 25% and beyond are possible. Each project merits its own assessment of the opportunities.

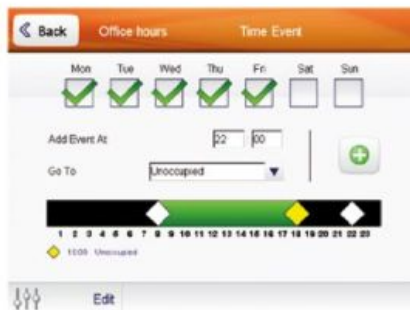

## FEATURES AND ADVANTAGES

### New System Manager

The Touch Pilot system manager is the user interface and allows building managers to control the Aquasmart system and associated components and features.

- Intuitive colour touch screen.
- A system set-up wizard leads installers through a number of easy intuitive steps to identify and configure the system and manage system set-up, operation and maintenance.
- Icon-driven menus easily and rapidly manage and maintain the HVAC system.
- Management of system parameters including cooling and heating set-points (terminals and cooling and/or heating plants) and occupied and non-occupied periods.
- Optimisation of energy consumption, monitoring of component operation and reporting of system faults.
- Management of occupied/unoccupied time schedules and smart start features to ensure that comfort requirements are met from the very beginning of the occupied period.

- The System Manager is compatible with a web browser, allowing user access to the system from a remote location such as a maintenance office within the building or from an off-site location where internet access is available. This facilitates ease-of-access and use and allows service and maintenance companies to offer remote service coverage without visiting the site, thus reducing carbon emissions due to transport.
- The availability of a new Carrier Apple application (HVAC smart browser) extends the accessibility to smart phones and tablets.



### System selection

■ The Aquasmart system is easy to select and configure with all units supplied from the factory with pre-installed, pre-configured and pre-tested controls and valves. The installer only needs to adjust the system parameters to the local building or application needs - a task made even easier with the New System Manager.

- Carrier has created a Quick Selection Guide that is available to rapidly identify and select the system components, facilitating the design process and saving time for designers and installers alike.
- Please contact your local sales office for a copy of this guide.



## FEATURES AND ADVANTAGES

### Building Management System Integration

■ The latest release of the Aquasmart Touch Pilot system manager enhances the capabilities to integrate Aquasmart systems with Carrier or third-party building management system front-end software. The new BACnet option allows

access to read and read/write system parameters from the building management system facilitating integration of Aquasmart within the overall building management.

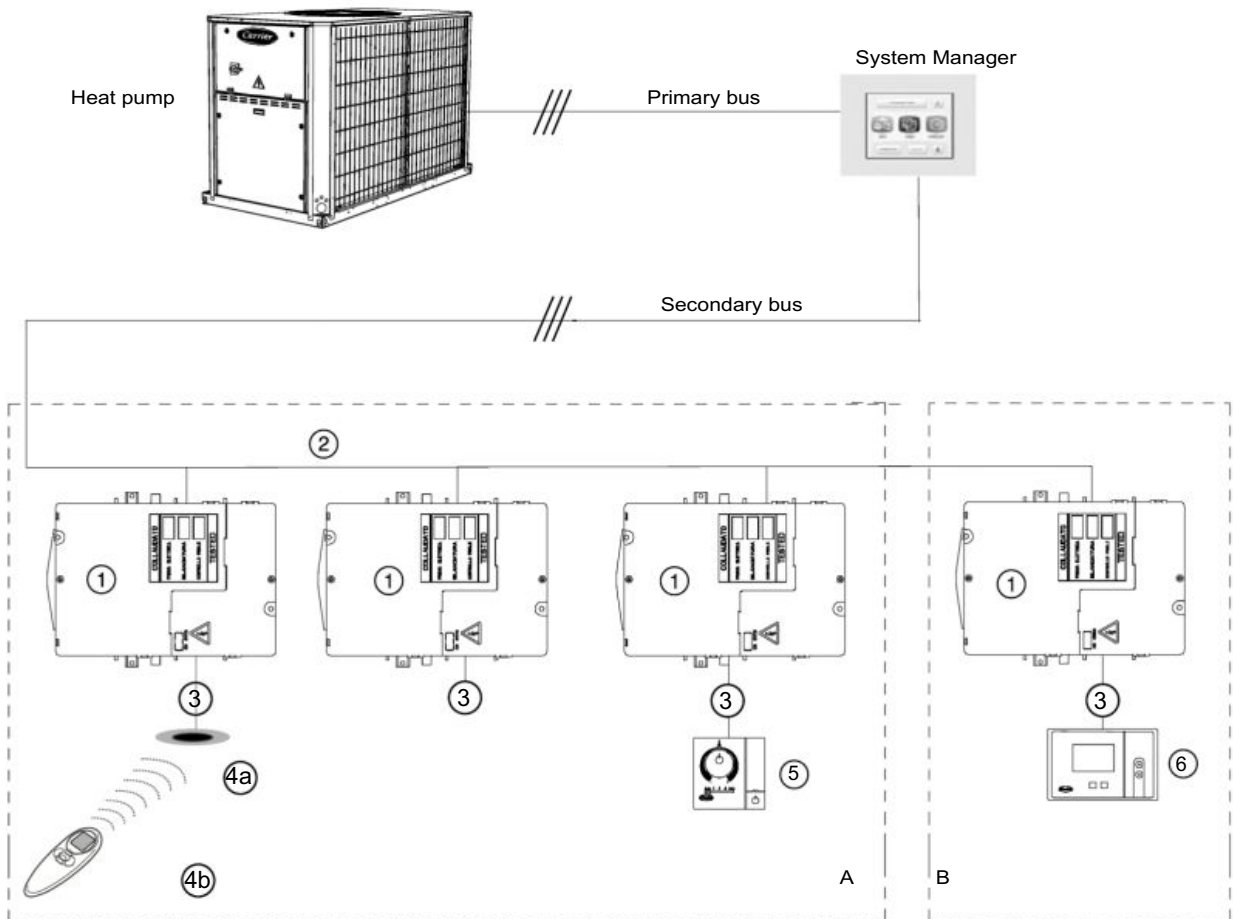

- Legend**
- ① NTC controller
  - ② Secondary communication bus
  - ③ User interface connection
  - ④ Infrared controller IR2
  - ⑤ SUI
  - ⑥ CRC2
  - A Room A
  - B Room B

FOR HVAC SYSTEMS

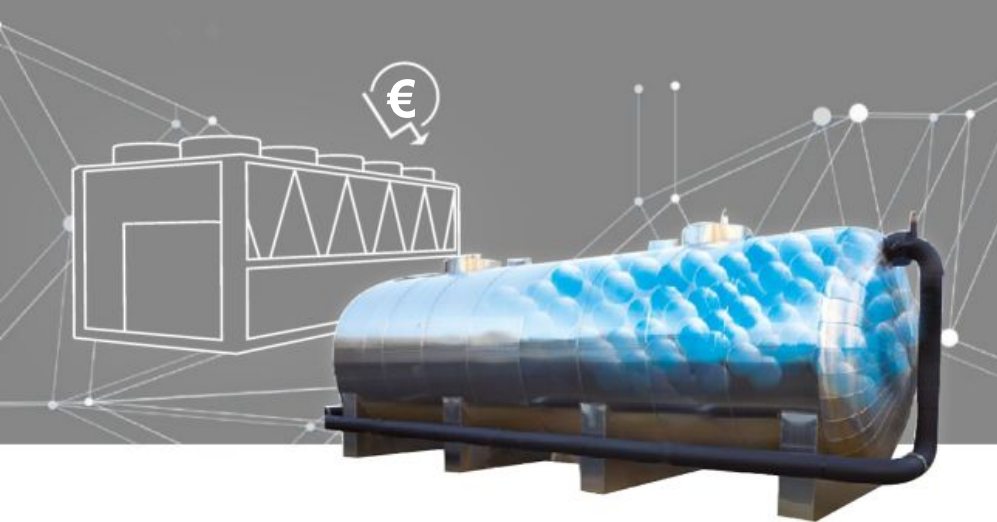

- TURNKEY SOLUTION
- PROVEN TECHNOLOGY
- UNIQUE EXPERTISE
- SUSTAINABLY DESIGNED
- REDUCED OPERATING COSTS
- 100% SMART -GRID COMPATIBLE
- NON-STOP SUPPORT

# Thermal Energy Storage

For HVAC systems with peak cooling demand >500 kW

In a global context affected by a continuous increase of electricity prices and the challenge of reducing our environment impact, energy must be saved and controlled. For energy demand management and sustainable approach to intelligent buildings, Carrier proposes the Thermal Energy Storage technology (TES) by latent heat.

Shift your electricity consumption from peak to off peak hour

The TES technology consists of Phase Change Materials (PCM) used to store in nodules the cooling thermal energy produced by chillers.

By storing the thermal energy during the night and releasing it during the day, this solution allows using the electricity at the lowest prices and avoids the peaks. By spreading the thermal energy production over 24 hours, TES can reduce the capacity of the chillers by 30% to 70%\*.

\*Source: Measured differences between equivalent systems designed with and without TES.

**MULTI  
APPLICATION**





## WORLDWIDE PLAYER IN THERMAL ENERGY STORAGE SYSTEMS

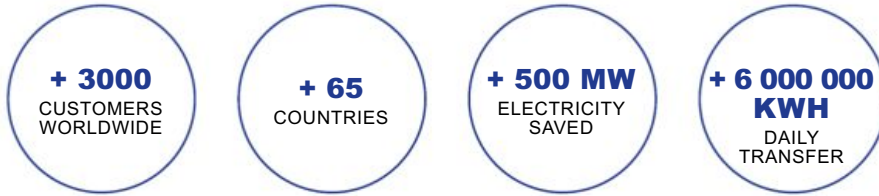

Source: Estimates based on existing TES solutions at customer sites.

### Histogram of a building's daily cooling needs and its electricity consumption profile

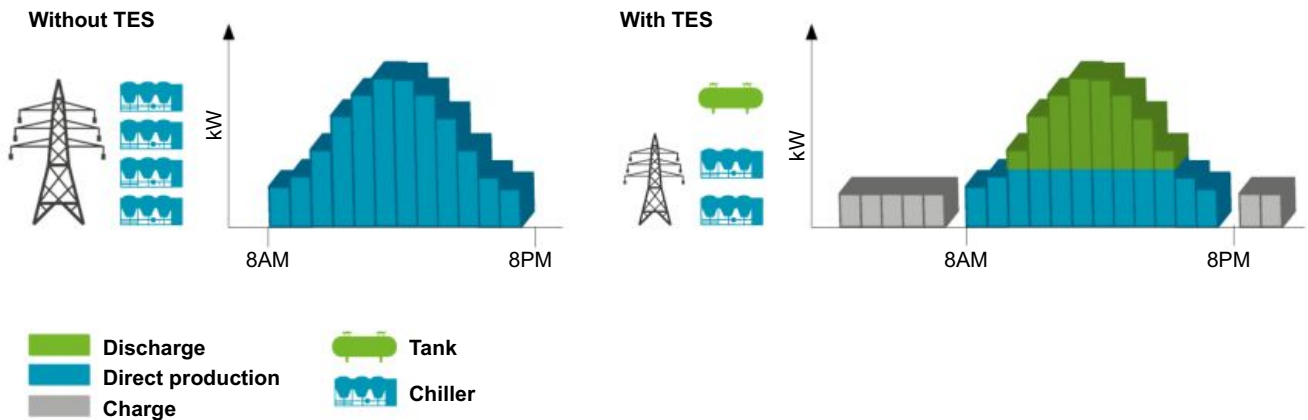

## A CUTTING-EDGE HVAC SOLUTION

### HVAC system designed with storage

The TES system along with your chillers is composed of one or several tanks filled with spherical elements called nodules that contain the Phase Change Materials (PCM). The use of PCM in nodules provides very high energy density and power exchange.

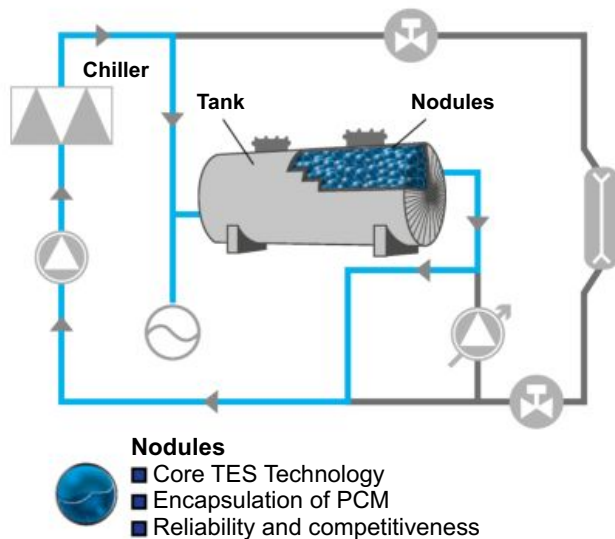

### A turnkey solution from project design to implementation

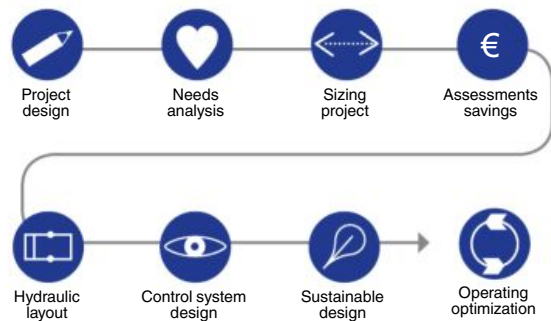

Carrier optimizes the design and the operation of your installation for each application as commercial or industrial buildings.

We assist the consulting engineers by adapting the hydraulic layout to each project: application, operating conditions and specific customer needs. Where necessary complementary technologies such as free cooling or energy recovery are integrated.





[www.carrier.com](http://www.carrier.com)

