



Alpha
TUFFBOX™
Jobber Drill Set
Gold Series

25pc / 1.0-13.0mm
(in 0.5mm increments)

**The Alpha Gold Series Drills
boast the highest quality M2 HSS Jobber Drill.**

- Titanium Nitride Coating increases hardness and decreases friction.
- Ideal for drilling Plastic, Wood and Metal, including Stainless Steel.
- Fully ground M2 HSS material increases drill life.
- 135° degree split point eliminates the need for centre punches or pilot drilling.

Code: **SM25PB**

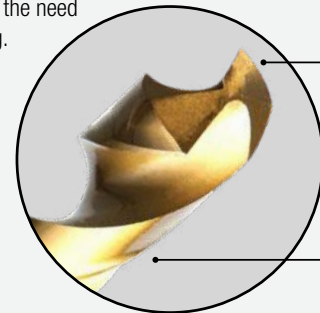

**135°
Split
Point**

**TITANIUM
NITRIDE
COATING**



Alpha
TUFFBOX™
Jobber Drill Set
Silver Series

25pc / 1.0-13.0mm
(in 0.5mm increments)

**The premium Alpha Drill Bits are ideal
for the widest range of materials.**

- Drills faster and longer.
- Ideal for general purpose drilling, especially non-ferrous metals.
- Fully ground M2 HSS material increases drill life.
- 118° degree split point eliminates the need for centre punches or pilot drilling.

Code: **SM25PBS**





XTRA CUTTING DISCS STAINLESS STEEL PLUS

10 pack - Plastic Box



The most advanced stainless cutting disc in the market.

New manufacturing technology has produced a disc with unparalleled performance and safety features that will maximise efficiencies and reduce costs in your stainless cutting jobs.

Extra Strong Reinforcing and high rigidity:

Produces precise, straight burr free cuts.

Highest quality contaminant free abrasive grain:

Produces a cool clean cut and stops discolouring of the metal.

Code: **GCDGP12510-10**



Chamfer External Deburrer For Threaded Rod

Repairs & Deburrs threads 3 - 20mm



Ideal for cordless drills



Non-slip 1/4" shank quick change

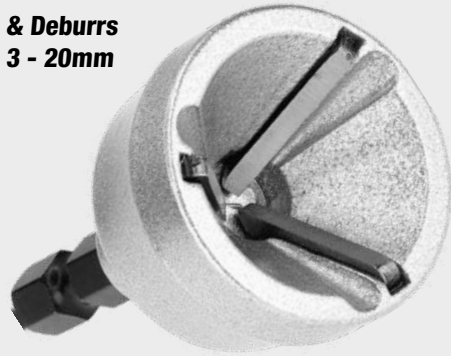

Code: **EDT01**

- Machined Aluminium body to reduce vibration
- 3 cutting edges made from HSS M2 Steel
- Suitable for hard steel, stainless steel, aluminium & plastic.



Scan for more information

MCC. Threaded Rod Cutter 8, 10, 12mm Cutting Capacity

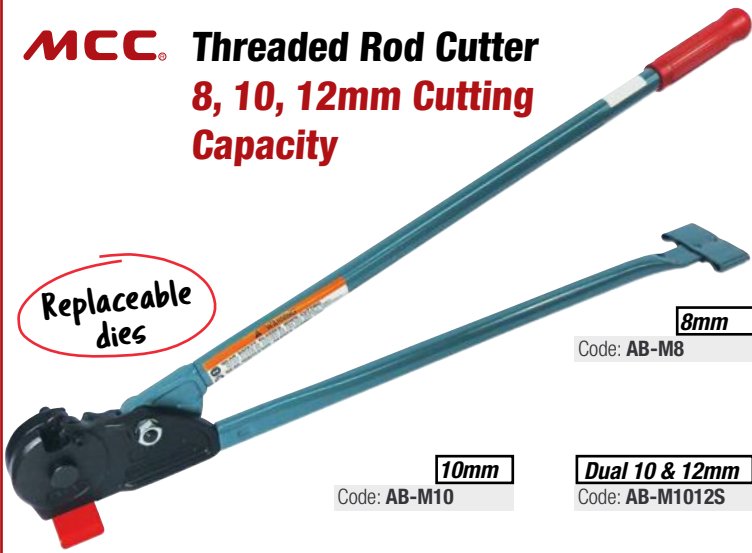

Replaceable dies

8mm
Code: AB-M8

10mm
Code: AB-M10

Dual 10 & 12mm
Code: AB-M1012S

- Designed to cut mild steel threaded rod.
- No cleaning and deburring work necessary after cut. Just screw on the nut.
- 2x Lifetime by double sided die design.
- Unique die design protects threaded rod from damage while cutting.
- Easy to replace dies.



Made in Japan
Quality since 1916

MCC. Compound Leverage Wire Rope Cutter 6mm Capacity



Up to 6mm
Steel Wire
rope

Code: **PWC-210**

Innovative design with gear connection mechanism achieved a significant high cutting leverage for extremely easy cutting work for thicker materials which used to be cut by both hands or bulky hand tools.



Made in Japan
Quality since 1916

MCC. Wire Rope Cutters

- An excellent cutter for steel wire rope.
- Shearing action of blades gives clean, sharp cutting of coarse or fine stranded materials with minimum distortion.

blades are interchangeable with bolt cutters



450mm

Code: **WC-0245**

600mm

Code: **WC-0260**

750mm

Code: **WC-0275**



Made in Japan
Quality since 1916

Magnetic Drilling Machines

Experience unmatched precision and efficiency with Euroboor magnetic drilling machines. Crafted to meet the highest industry standards. Backed by years of expertise, we understand exactly what you need to get the job done right.

Designed for power and performance, our magnetic drilling machines make drilling large holes in metal faster and easier than ever. From compact portability to impressive capabilities, our full range covers diameters from 12 mm up to an astounding 200 mm. Choose Euroboor — where innovation meets reliability.

- Carefree and safe drilling with Euroboor since 1977
- Euroboor stands for premium quality
- Service points all over New Zealand
- Spare parts always available
- Extend your warranty by registering your machine on the Euroboor website

CHECK THE FULL EUROBOOR RANGE ON TRUCUTNZ.COM

ECO.30

Annular cutters Ø	Motor power:
30 mm	900 w
Magnetic force:	Machine weight:
1200 kg	8,5 kg
Twist drills Ø	13 mm Weldon
Countersinking Ø	35 mm
Stroke	90 mm
Speed (no load)	775 rpm
Speed (load)	400 rpm
Spindle (Weldon)	19,05 mm



Scan for more information

ECO.50S

Annular cutters Ø	Motor power:
50 mm	1250 w
Magnetic force:	Machine weight:
1700 kg	11,2 kg
Twist drills Ø	23 mm
Countersinking Ø	55 mm
Stroke	170 mm
Speed (no load)	(I) 315 rpm (II) 690 rpm
Speed (load)	(I) 235 rpm (II) 425 rpm
Spindle (Weldon)	MT3 19,05 mm



Scan for more information

ECO.32-T

Annular cutters Ø	Threading Ø
32 mm	M12
Motor power:	Magnetic force:
1000 w	1500 kg
Machine weight:	Rotating
12 kg	L / R
Twist drills Ø	13 mm
Countersinking Ø	40 mm
Stroke	150 mm
Speed (no load)	100 - 600 rpm
Speed (load)	225 rpm
Spindle (Weldon)	19,05 mm



Scan for more information



Carbide Burr Sets

5 piece - Metric or Imperial

TUFF CARBIDE BURR SETS have CNC precision-ground flutes for reliable chatter-free operation and longer life.

Carbide Burrset

5pc 1/4" or 6mm shank

- Contents:
- 1x SB-3 10mm
 - 1x SC-3 10mm
 - 1x SC-5 12mm
 - 1x SF-3 10mm
 - 1x SF-5 12mm

Double Cut 6mm Shank

Code: **TCBMSET5**

Double Cut 1/4" Shank

Code: **TCBISET5**

Carbide Burrset

5pc 1/4" shank Aluminium

- Contents:
- 1x SA-5AL 1/2"
 - 1x SC-5AL 1/2"
 - 1x SD-5AL 1/2"
 - 1x SE-5AL 1/2"
 - 1x SF-5AL 1/2"

Aluminium 1/4" Shank

Code: **TCBASET5**



Spot Weld Drills

HSS - Cobalt Series

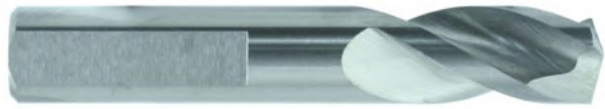

COBALT SERIES

HEAVY DUTY

- Premium industrial grade HSS Steel
- For drilling out spot welded panels
- 1 flat on shank for spot weld drill

Size mm	Code
6.5 (Short)	9S65
8.0 (Short)	9S80
8.0 (Long)	9L80



Spot Weld Drills

HSS - Cobalt / Titanium Nitride Coated



GOLD SERIES

TITANIUM NITRIDE COATING

- TiN coated for lubricity and longer life
- For drilling out spot welded panels
- 1 flat on shank for spot weld drill

Size mm	Code
8.5 (Short)	9S80T
8.0 (Long)	9L80T
8.0 (Extra Long)	9XL80T



Spot Weld Drills

HSS - Cobalt / DURA Coated



COBALT SERIES

- DURA coated ideal for hi-tensile alloys
- For drilling out spot welded panels
- 1 flat on shank for spot weld drill

Size mm	Code
8.0 (Short)	9S80DUR
8.0 (Long)	9L80DUR



Screw Extractor & Left hand

Cobalt Drillset 10pc

HEAVY DUTY

For the removal of damaged screws, stud & bolts. Left hand drill bits remove fasteners or creates the pilot hole required for a screw extractor.

135° split point for extra gripping power.

Fully ground HSS Cobalt increases strength & drill life.



Heavy Duty Left Hand Drills
 Sizes: 5/64", 7/64", 5/32", 1/4" & 19/64".
 Screw Extractors
 Sizes: #1, #2, #3, #4 & #5.

Code: **9SECOL-SET10**



Screw Extractor

Drillset 5pc

HEAVY DUTY

Spiral tapered flute for deep embedment which increases grip as the resistance increases.

Reverse tapered flute for extra gripping power.



Screw Extractors
 Sizes: #1, #2, #3, #4 & #5.

Code: **9SE-SET5**



Left Hand

Cobalt Drillset 5pc

HEAVY DUTY

135° split point for extra gripping power.

Fully ground HSS Cobalt increases strength & drill life.

For the removal of damaged screws, stud & bolts.



HSS COBALT

Heavy Duty Left Hand Drills
 Sizes: 5/64", 7/64", 5/32", 1/4" & 19/64".

Code: **9COL-SET5**



Midget Cable Cutter - 215mm

Capacity: 3.0mm Cable



Code: CC-0300

Wire Cutter - 200mm

Capacity: 4.0mm (80HRB)

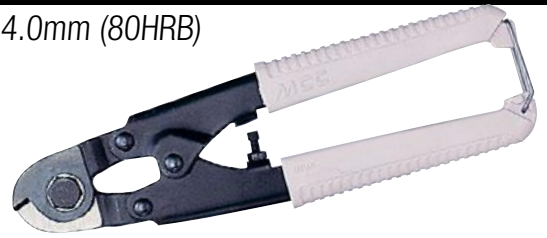

Code: MS-0020

Midget Cutter - 210mm

Capacity: 4.0mm (80HRB)



Code: MC-0020

Midget Nipper - 210mm

Capacity: 3.5mm (80HRB)



Code: MN-0020

Fence Cutter - 210mm

Capacity: 3.0mm (80HRB)



Code: MCF-200

Strap Cutter - 240mm

Capacity: 32mm x 0.9mm



Code: SC-0200

End Cutter - 215mm

Capacity: 3.5mm (80HRB)



Code: ME-0020

Midget Cutter Special - 205mm

Extra Hardened

Capacity: 4.0mm (80HRB)

2.0mm (Hard 31HRC)



Code: MCS-0020

MCC. Cutter & Bender 13-16mm Cutting Capacity



Made in Japan
Quality since 1916

- Suitable for cutting and bending reinforcing bars and rods.
- Portable compact design with well balanced positioning of blades and rollers for suitability at job site work.

Code: SCB-16

BLEISPITZ® Paint Markers - Fine Tip 1.0 - 2.0mm



- Quality paint marker for professional, industrial use.
- For highly opaque marking of almost any materials such as metal, glass, plastic, stone, carton, tiles, wood.
- For marking and writing especially on dark surfaces.
- Waterproof, quick-drying ink

10 packs

DESCRIPTION	CODE
Paint Marker Fine Tip Red / Pack 10	0914
Paint Marker Fine Tip Blue / Pack 10	0938
Paint Marker Fine Tip Yellow / Pack 10	0952
Paint Marker Fine Tip White / Pack 10	0976
Paint Marker Fine Tip Black / Pack 10	0990



BLEISPITZ® Paint Markers - 4.0mm



- Quality paint marker for professional, industrial use.
- For highly opaque marking of almost any materials such as metal, glass, plastic, stone, carton, tiles, wood.
- For marking and writing especially on dark surfaces.
- Waterproof, quick-drying ink

DESCRIPTION	CODE
Paint Marker Yellow / Card 1	1645
Paint Marker White / Card 1	1652
Paint Marker Black / Card 1	1669
Paint Marker Red / Pack 10	0488
Paint Marker Blue / Pack 10	0501
Paint Marker Yellow / Pack 10	0525
Paint Marker White / Pack 10	0549
Paint Marker Black / Pack 10	0563



BLEISPITZ® Profi-Marker Welding

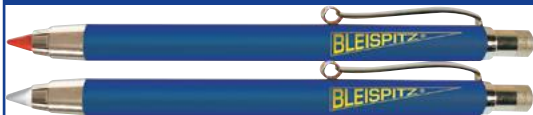

- Made of durable brass metal
- Long lasting, white, fireproof line, clearly visible even through welding goggles.

Red all-writer lead for marking on cold metal, steel and almost any materials

Soapstone lead for marking on metal and steel, welding and cutting up to 2.000 °C

DESCRIPTION	CODE
Profi-Marker Welding Set	0440
Profi-Marker Soapstone Lead Refills / 5pk	0464
Profi-Marker Red Lead Refills / 5pk	0112



BLEISPITZ® Long Reach Bohr Marker



- Waterproof on almost any surfaces
- Individually carded

DESCRIPTION	CODE
Long Reach bohr-Marker Black / Card 1	0587
Long Reach bohr-Marker Black	1102



Sterling® E Series Tapes



10m x 25mm

Code: 1089

8m x 25mm

Code: 889

5m x 19mm

Code: 589

3m x 16mm

Code: 389

- The most consistently accurate value tape measure range, the Sterling e tapes are a great economy option
- Rubber back case • Metric markings • 3 rivet end hook
- Available in Display Box of 12

Non-slip ABS casing

Superior internal mechanism

EASY READ

8M x 27mm WIDE BLADE

Code: TMFXE8027

Double sided blade printing

Reinforced dual-hook

Clear markings

Wide nylon coated blade

Ultimax PRO

Tape Measure

EASY READ

10M x 27mm WIDE BLADE

Code: TMFXE1027

MONOBLOCK STAINLESS

VERNIER CALIPER



Ideal for
**INDUSTRIAL
USE**



Code: **DCMB150** 150mm* Code: **DCMB200** 200mm* Code: **DCMB300** 300mm**

- Graduation: 0.05mm / 1/128"*
- Graduation: 0.02mm / 0.001"**
- Accuracy: 0.03mm
- Strictly made in accordance with DIN862
- With locking screw for stable reading
- Made of solid stainless steel
- With fine adjustment
- Distinct lines and figures etched against satin chrome finish
- 4 measuring uses: outside and inside diameter, step and depth



Made in Italy



DIGITAL EZI-READ

VERNIER CALIPER



Ideal for
**INDUSTRIAL
USE**



Code: **DC150-1005** 150mm Code: **DC200-1010** 200mm Code: **DC300-1015** 300mm

- Large EZI-READ screen.
- Strictly made in accordance with DIN862.
- Silky smooth movement throughout.
- Reliable High Precision.
- Excellent surface and stability.
- High durability and long lifetime.
- Hardened, ground and lapped measuring surfaces.
- 4 measuring uses: outside and inside diameter, step and depth



Made in Italy



GENERAL PURPOSE

MEASURING SET - 2PCS



- Big Screen Digital Caliper 0-150mm



Made in Italy



- Digital Outside Micrometer 0-25mm



Code: **DCMSET2**

GENERAL PURPOSE

MEASURING SET - 4PCS



- Big Screen Digital Caliper 0-150mm



Made in Italy



- Outside Micrometer 0-25mm
- 90° Beveled Edge Square 100mm
- Steel Ruler 150mm

Code: **DCMSET4**

COMES WITH FREE SAWBLADE

Dry cut saw EDC.355

Our powerful machine offers convenience and safety with an adjustable sawing angle (0° to 45°), a molded aluminum base, and three attachment points for secure mounting. It features an ergonomic handle, safety button, transparent shield, robust clamp for precise material clamping, dust collection tray, and soft-start functionality.



Technical data	
Dimensions (l x w x h)	620 x 350 x 630 mm
Weight	18.6 kg
Motor power	2,480 W
Cutting speed (no load)	1,450 rpm
Cutting angle	adjustable, 0° - 45°
Bore size	Ø 25.4 mm
Cutting capacity at 0°	● 120 mm
	■ 105 mm
	■ 90 x 145 mm
Cutting capacity at 45°	● 90 mm
	■ 80 mm
	■ 90 x 80 mm
Max. Ø saw blade	355 mm



TAP & BUTTON DIE WRENCHES - Zinc Alloy

T-Tap Wrenches



1/4" M3-M6
Code: **TW14**

1/2" M6-M12
Code: **TW12**

T-Tap Ratchet Wrenches

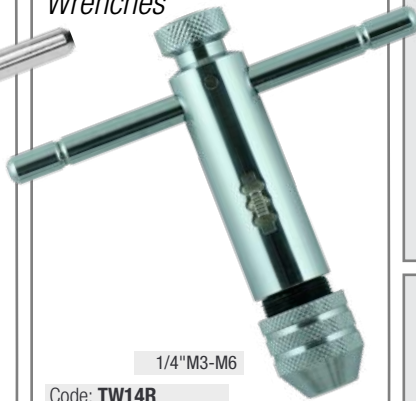

1/4" M3-M6
Code: **TW14R**

1/2" M6-M12
Code: **TW12R**

Tap Wrenches

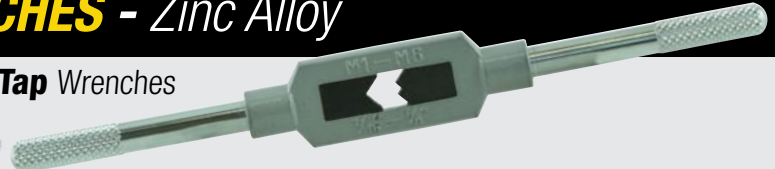

- | | |
|---------------------------------|---------------------------------|
| #00/M1-M6
Code: TW-00 | #0/M3-M12
Code: TW-0 |
| #6/M6-M20
Code: TW-6 | #7/M10-M25
Code: TW-7 |
| | #8/M20-M38
Code: TW-8 |

Button Die Wrenches



- | | | |
|----------------------------------|--|----------------------------------|
| Small - 1"
Code: BDW-1 | Medium 1-1/2"
Code: BDW-1.12 | Large - 2"
Code: BDW-2 |
|----------------------------------|--|----------------------------------|



VERSADRIVE®

LESS DOING... MORE DONE!

Impact Reamers



VersaDrive Reamers are the perfect hole alignment and enlarging tools for metalworkers and steel erectors for keeping the job moving when a hole is misaligned or the incorrect size for the fixing.

Featuring a specially designed 6-flute cutting geometry and Titanium coating, VersaDrive Reamers are fully impact-rated and perform fastest when used with an impact wrench providing ultimate cutting performance with virtually no power tool kickback.

Size	Code
8mm	501030-0080
10mm	501030-0100
12mm	501030-0120
14mm	501030-0140
16mm	501030-0160
18mm	501030-0180
20mm	501030-0200
22mm	501030-0220
24mm	501030-0240
26mm	501030-0260



IMPACT RATED

Impact Reamer Set
5 Pieces - Metric
Sizes: 12, 14, 18, 22 & 26mm
Code: 501030-SET

Impact Reamer Set
3 Pieces - Metric
Sizes: 14, 18, & 22mm
Code: 501030-3SET

IDEAL FOR



Scan & Learn more | ▶



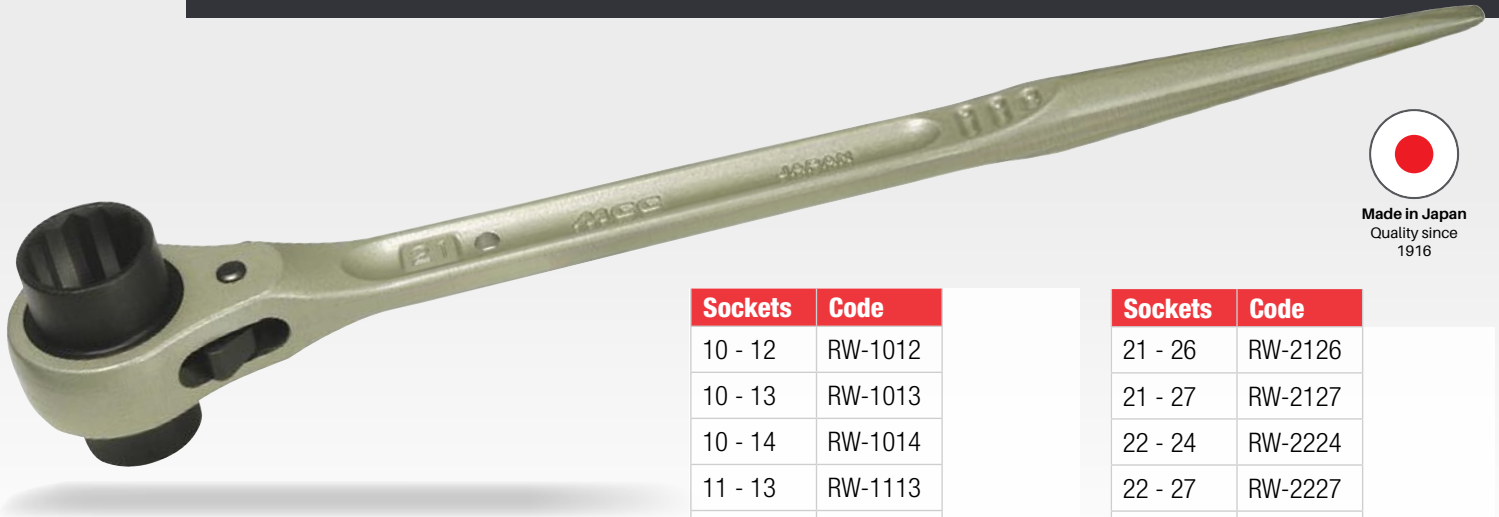

Made in Japan
Quality since
1916

- Long Handle for extra leverage
- Drop forged from special alloy steel with chrome molybdenum insert.
- Each wrench has two sizes and reversible ratchet with the press of the thumb.
- Tapered handle is also used to align holes for bolts and nuts.

Sockets	Code
10 - 12	RW-1012
10 - 13	RW-1013
10 - 14	RW-1014
11 - 13	RW-1113
12 - 14	RW-1214
13 - 17	RW-1317
13 - 19	RW-1319
14 - 15	RW-1415
14 - 17	RW-1417
17 - 19	RW-1719
17 - 21	RW-1721
17 - 22	RW-1722
19 - 21	RW-1921
19 - 22	RW-1922
19 - 24	RW-1924
21 - 24	RW-2124

Sockets	Code
21 - 26	RW-2126
21 - 27	RW-2127
22 - 24	RW-2224
22 - 27	RW-2227
23 - 26	RW-2326
24 - 26	RW-2426
24 - 27	RW-2427
24 - 30	RW-2430
26 - 32	RW-2632
27 - 30	RW-2730
27 - 32	RW-2732
30 - 32	RW-3032
32 - 35	RW-3235
32 - 36	RW-3236
35 - 41	RW-3541
36 - 41	RW-3641

Sterling Black Panther Shears

Sterling Black Panther shears are premium tailoring scissors of exceptional quality. Featuring supremely sharp stainless steel blades and ambidextrous comfort grip handles, these shears glide through tailoring, upholstery and fibreglass industry applications.



280mm
Code: 29-911

300mm
Code: 29-912

280mm
Code: 29-915

300mm
Code: 29-916

MCC Adjustable Wrenches



Made in Japan
Quality since
1916

- Smooth jaw movement
- Tight jaw with precise adjustment
- Heavy duty and professional quality made of high grade alloy carbon steel and drop forged process.

Size mm	Jaw Opening	Code
100	13mm	MW-HD10
150	20mm	MW-HD15
200	24mm	MW-HD20
250	29mm	MW-HD25
300	34mm	MW-HD30
370	44mm	MW-HD37

The perfect match for air, electric, or manual impact wrenches.

Forged from chrome molybdenum steel hardened and chemically blacked for corrosion protection.

- Heavy Duty Quality
- Chrome Molybdenum Steel
- Corrosion Protected
- Ideal for Impact Wrenches

Size mm	Code
Torx 10	TISTX10
Torx 15	TISTX15
Torx 20	TISTX20
Torx 25	TISTX25
Torx 27	TISTX27
Torx 30	TISTX30
Torx 40	TISTX40
Torx 45	TISTX45
Torx 50	TISTX50
Torx 55	TISTX55



Size mm	Code
12mm	TISS12
13mm	TISS13
14mm	TISS14
15mm	TISS15
16mm	TISS16
17mm	TISS17
18mm	TISS18
19mm	TISS19
20mm	TISS20
22mm	TISS22
24mm	TISS24
30mm	TISS30
32mm	TISS32



TOUGH ENOUGH.



Size mm	Code
10mm	TISD10
12mm	TISD12
13mm	TISD13
14mm	TISD14
15mm	TISD15
16mm	TISD16
17mm	TISD17
18mm	TISD18
19mm	TISD19
20mm	TISD20
21mm	TISD21
22mm	TISD22
24mm	TISD24
27mm	TISD27
30mm	TISD30
32mm	TISD32



Size mm	Code
Hex 4	TISHX04
Hex 5	TISHX05
Hex 6	TISHX06
Hex 7	TISHX07
Hex 8	TISHX08
Hex 10	TISHX10
Hex 12	TISHX12
Hex 14	TISHX14
Hex 17	TISHX17

Impact DEEP Socket Set
6 Point x 1/2" drive
10, 13, 14, 15, 16, 17, 18, 19, 24mm

Impact TORX Socket Set
1/2" drive
T20, T25, T27, T30, T40, T45, T50, T55, T60

Impact HEX Socket Set
1/2" drive
H4, H5, H6, H8, H10, H12, H14, H17

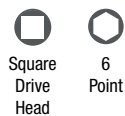

Code: TISDSET9

10



Code: TISTXSET9



Code: TISHXSET8



HEAVY DUTY STEEL TACKER

NEW & IMPROVED MODEL

Durable all-steel construction



TOUGH ENOUGH.

Power adjustment control system

Anti-slip colour handle



Low Staple refill window

Bottom loading for easy loading & jam clearing

Code: TST-8651



140 T50 STAPLE SERIES SPECIFICATION:

Interchangeable with Sterling 140/8-14mm, Arrow 140/8-14mm, Arrow T-50 5/16" - 9/16", & Rapid 140/8-14mm Staples.



STEEL HEAD HAMMER TACKER

NEW & IMPROVED MODEL



140 T50 SERIES 6, 8, 10 & 12mm

15% Less Fatigue**

Up to 26% Less Weight*

- Low staple indicators on the top & sides.
- Anti-slip handle sleeve for a firm grip on every hit.
- Capacity for 2 full strips of heavy duty staples.
- Compatible with Arrow T50 or Sterling Rapid 140 Series.
- Bottom loading for easy loading & jam clearing.

Code: TSH-8651



*Compared to other steel body models. **Reduces fatigue based on feedback from user testing.

ONSITE+

Non-Slip Shank

Premium AlCrN Coating
ensures durability and longevity

10mm Cutting Depth
suitable for thicker workpieces

Suits Power Drills

No Pre-drilling required
Unique Patented Step Tip

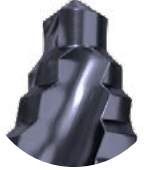

The next evolution of the **Alpha Onsite+** range, this tool is designed for maximum efficiency so you can save time on the job and clock-off earlier than ever before.

10mm Cutting Depth - Suitable for thicker workpieces up to 10mm, unlike conventional step drills which are limited to 4mm.

Fast Drilling Process - The overall drill time is 6x faster than regular step drills thanks to four high-performance cutting edges.

No Pre-drilling needed - Patented Step Tip design eliminates the need to pre-drill a pilot hole.

Deburring Eliminated - The next larger step diameter performs the function of deburring while drilling

Less Tool Wear - Premium AlCrN multi-layer protection coating ensures durability and tool longevity

Ideal for:



Steel



Wood



Plastic



Stainless Steel

Steps	Code
3.3, 4.2, 5.0, 6.8, 8.5, & 10.2mm M4 - M12	9STM4-M12DSD
4.0, 5.0, 6.0, 7.0, 8.0, 9.0, 10.0, 11.0 & 12.0mm	9STM4-12DSD
8.0, 10.0, 12.0, 14.0, 16.0, 18.0 & 20.0mm	9STM8-20DSD
9.0, 11.0, 13.0, 15.0, 17.0 & 19.0mm	9STM9-19DSD

Sustainable Packaging



Scan & Learn more | ▶

Distributed by: