



**PACIFIC KITCHENS**  
& CATERING EQUIPMENT

# Cooking Sorted

Issue 5

## **Words of the Wise**

*Admir Mullaaliu - SKOPE Head of Sales*

## **The true beauty of SKOPE**

*Take a look at how a SKOPE under bar chiller will make your restaurant look sleek and elegant.*

## **SKOPE Connect Eye**

*The future is here!*

## **Now on SALE!!**

*Terms & Conditions apply\**

## **The Kitchen Plan**

*Scope for your next SKOPE*

# Words *of the* Wise

SKOPE Refrigeration is a New Zealand-based, family-owned company with a global reputation for designing and manufacturing premium commercial refrigeration solutions. SKOPE products are designed to withstand some of the toughest conditions.

From Alice Springs to Denarau Island, our products are built to last thanks to a robust and thorough design and manufacturing process.

Paired with this is our superior technology where we place control into your hands, allowing you to configure your SKOPE product to the best suit your environment.

## Admir Mullaaliu

SKOPE Head of Sales – Food Service,  
New Zealand & Pacific Islands



## The true beauty of **SKOPE**

The lights are dimmed. The music is humming. The drinks are poured. And at the bar's center is the most elegant element of all...  
your SKOPE Backbar!

- Market-leading dimmable LED full-height strip lighting
- Quieter running with built-in hush mode
- Unrivaled energy efficiency – up to 63% reduction in energy consumption.
- Truly green natural refrigeration technology
- Self-closing swing doors with built-in locking tabs on every door
- Fully front-breathing interchangeable modular cartridge for quicker, safer servicing
- NB: A benchtop is not included with this model. The pictured product includes an optional benchtop, which can be priced and supplied separately

# SKOPE the future is here!

connectEYE

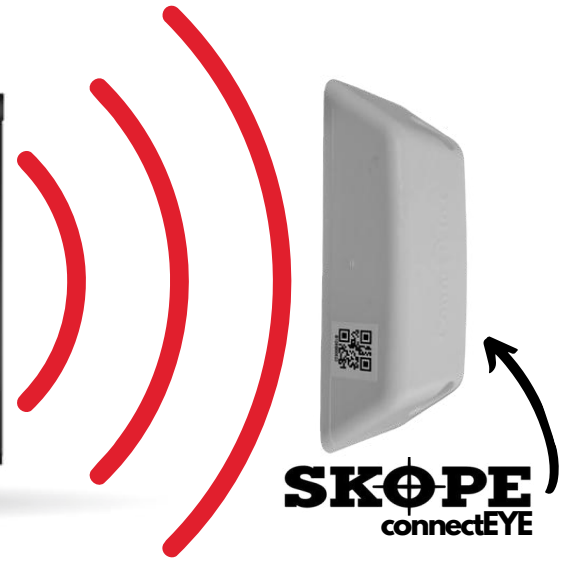

## Compatible with your Fridge, Freezer, or Cool Room

SKOPE-connectEYE is a small device with big implications for commercial refrigeration - regardless of brand. Place the EYE within your existing fridge, freezer, or cool room and start benefiting from your temperature data

The EYE is a portable iteration of the smart controller found in many new SKOPE fridges and freezers. Use the EYE in prior-generation SKOPE products or any other brand of fridge, freezer, or cold room. You can collect temperature data with extreme accuracy, allowing you to:

- Simplify and support compliance management
- Avoid food waste with temperature alerts
- Track door openings on your refrigeration to better understand customer demand



### Take the Hassle out of HACCP Compliance

SKOPE-connectEYE collects temperature data so you don't have to. Easily export at the touch of a button.



### Temperature Alerts to your App

If anything threatens the internal temperature of your fridge, freezer, or cool room, you'll be notified via the SKOPE-connect app.



### Measure Door Openings

Test the popularity of new product in a merchandiser or see how often your fridge is used by staff.

# Now on SALE!



## SKOPE Two Glass Swing Door Tropical Backbar



**SAVE**  
**\$200**  
 Valid till 31st March, 2023  
 T&C Applies\*

**WAS \$10,800.00**  
**NOW \$10,600.00**

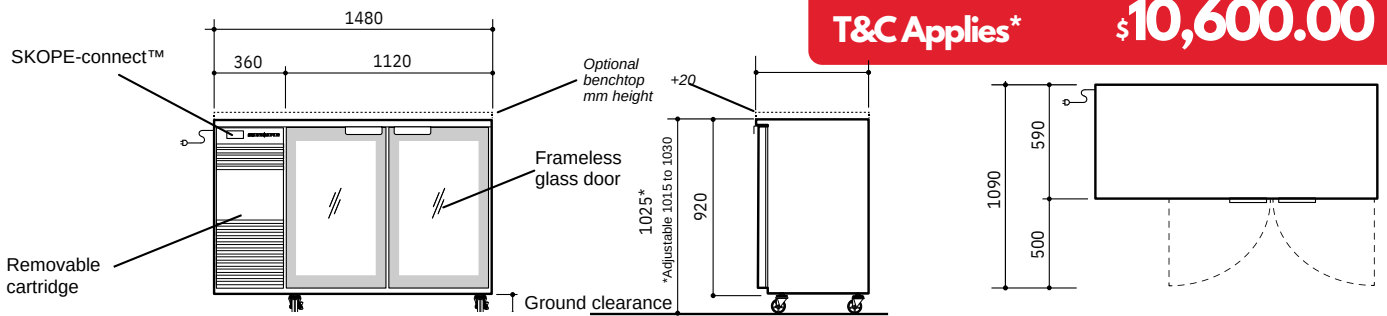

Cabinet		
Type	BackBar	
Finish	Powdercoat galvanised steel or stainless steel	
Insulation	Type	PU foam
	Thickness (mm)	50
Blowing Agent	Type	Cyclo-iso pentane (CSH10/CSH12)
	Thickness (mm)	50
Doors	Type	Glass swing door (double glazed, heated glass)
	Opening Size	Height (mm) 730 Width (mm) 460
Shelving	Type	Four adjustable height plastic-coated wire shelves
	Capacity	4 x outer shelf (497W x 440D)
Lighting*	1 x 16W dimmable, cool white (5500-6500K) LED strip on cabinet ceiling	

Dimensions†			
	External	Internal	Packed
Width (mm)	1480	1020	TBC
Depth (mm)	590	530	TBC
Height (mm)	1025 (std. castors)	758	TBC
	920 (plinth mount)		
Weight (kg)	180		TBC
Capacity (L)	410		
Footprint (m <sup>2</sup> )	0.87		

Product Loading				
Facing	330 ml can	28	600 ml bottle	28
Loading	330 ml can	168	600 ml bottle	168

Performance		
Product Temperature Range (°C)	1 to 4 (adjustable* from 0 to 15)	
Maximum Ambient Temperature (°C)	40	
Sound Level (dB(A))	Standard	< 66
	Hush Mode*	< 62

Greenhouse and Energy Minimum Standards (GEMS)	
Star Rating	6
Product Temperature Class	M1 (-1 to 5°C)
Total Energy Consumption	5.03 kWh/24 h
Annual Running Costs	\$551 (@ \$0.30/kWh)

Electrical	
Supply	220-240 volts a.c., 50 Hz, single phase supply
Cord	1.9 m power cord with 3-pin, 10 amp plug
Current draw (A)	2.6

# Get in touch with us for more

✉ [sales@pkce.com.fj](mailto:sales@pkce.com.fj) ☎ 998 9522

# the Kitchen plan

Planning to build a commercial kitchen?  
Do you need a premium range of kitchen equipment that will  
suit all your specific needs?

Every inch of your kitchen can use a SKOPE.



Glass Door  
Upright Display



Solid Door  
Upright Fridge



Blast Chiller



Ice Cube  
Maker

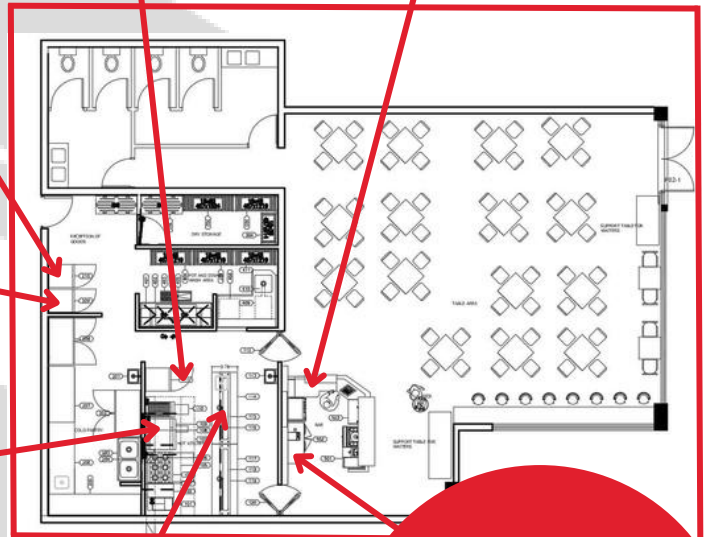

2 Drawer  
ChefBase



Salad  
Preparation  
Fridge



Glass Swing  
Door Fridge

If it's got anything  
to do with SKOPE...  
we've got you covered!

Talk to us to get a fully  
**SKOPE**  
backed service arrangement

998 9522

sales@pkce.com.fj

SKOPE: I have come to about this highly decorated quality range, one of its kind cooling & freezing units, in my 18 years of the hospitality business. Has always stood out in performance, reliability & the test of time, the design is very spacious with a gentle open & close door system. The temperature control is superb & very accurate which allows set temperatures to settle down in products very well. Overall, it's safe, built strong & lasts long. It's not just a product but a strong emerging relationship in the market.

**Chef Sarj**

*Decorated Executive Chef*



# Coming Next in Cooking Sorted



*General Refrigeration  
and so much more...*

**Anish Kumar**

Sales & Development - PKCE

☎ +679 9989522

✉ sales@pkce.com.fj

**Ashneel Raj**

Sales & Development - ARS

☎ +679 9980406

✉ sales@altituderefrigeration.com.fj

**Ana Tawawa**

Showroom Co ordinator

☎ +679 9989528

✉ showroom@pkce.com.fj

**Dennish Chand**

Marketing Co ordinator

☎ +679 9989537

✉ marketing@altituderefrigeration.com.fj

**Talk  
to us today!**