

Built for Battle® DD-4S

4" Double-Diaphragm Pump



Our very first pump model from 1994, the DD-4S may be small in stature, but it is “super” on performance and reliability. The DD-4S is preferred by contractors and rental companies alike for its steady performance, application versatility and simplicity.

Duty Points

Max Flow: 450 GPM/ 1703 LPM

Max Head: 90 TDH/ 27.47 m

Max Suction Lift: 28' ft/ 8.53 m

Solid Handling: 3.5"/ 88.9 m

Max CFM: 40 CFM

Market Segment

Construction

Municipal: Waste Water

Industrial

Petrochemical

Oil & Gas

Mining

Food Processing



Components of this product are protected by one or more patents. The protected components and the associated patent(s) are identified at: www.msp-pumps.com

Standard Features

- Heavy Duty Battery and Cables
- Camlock or Bauer Hose Fittings
- Large Fuel Filtration
- Lockable Fuel Cap
- Fuel Gauge
- Heavy Duty Lifting Bale
- 5,000 lbs Front Jackstand

- Pushrod Protection Covers
- Powder-Coated Frame
- DOT Trailer Lights

Options

- Skid Mounted
- AUTO Start Control Panel
- GPS Telematics
- Electric Drive Pump Package Available

Flow Chart

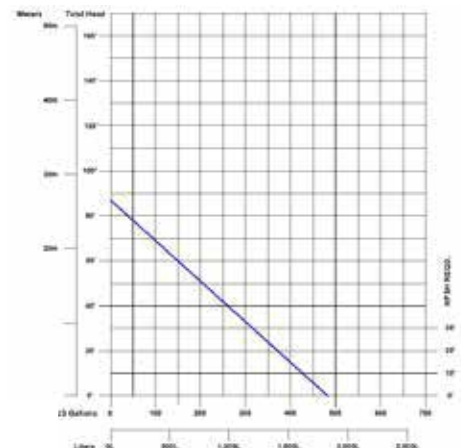

SOLD BY



info@aquosis.com
1.877.907.7852



HERE FOR YOU
904.389.6114



Built for Battle® DD-4S

Specifications

Engine		Frame	
Make/Model	HATZ 1B50E	Frame Construction	8" Square Steel Tubing
Horsepower	6.4 hp @2000 rpm/7.1 hp	Fuel Capacity	41.0 gal (132.5L)
Safety Shutdowns	Low Oil Pressure	Lifting Bale	Heavy Duty Single Point
Engine Displacement (liters)	27.20 cu (0.413)/31.55 cu	Tie Downs	(4) Heavy Duty Tie-Down Points
Engine Type	One Cylinder, Air-Cooled, Diesel	Height	60.375" (153.35 cm)
Daily Fuel Consumption	4 – 5 gal/day	Width	67" (170.18 cm)
Max Continuous Run Time	8 – 10 days 192 – 240 hrs	Length	108" (274.64 cm)
Standard Equipment	Instrument Control Panel w/Hour Meter	Weight	1780 lbs (807 kg)
		Wheels & Tires	15" P205/75R15 Radial
		Axle Type	3,500 lbs Torflex

Pump			
Pump Housing	A-36 Steel	Max Operating Speed	60 rpm (Gearbox) 1800 rpm (Engine)
Pump Capacity Suction	Gray Diaphragms (5" Total Travel) 450 GPM @ 1800 rpm (1703 LPM)	Max Operating Temperature	160°F / 71.11°C
Bursting Diaphragm Pressure	90 psi	Flapper Valves	Weighted, Full-Flow, Reinforced Rubber
Max Operating Diaphragm Pressure	10 psi	Max Suction Lift	28' ft (8.53 m)
Max Head Pressure	90 TDH (27.47 m)	Air Handling	40 CFM
		Suction & Discharge Valve Seats	Stainless Steel, 3/8" Plate
		Solid Handling	3.5" (88.9 mm)

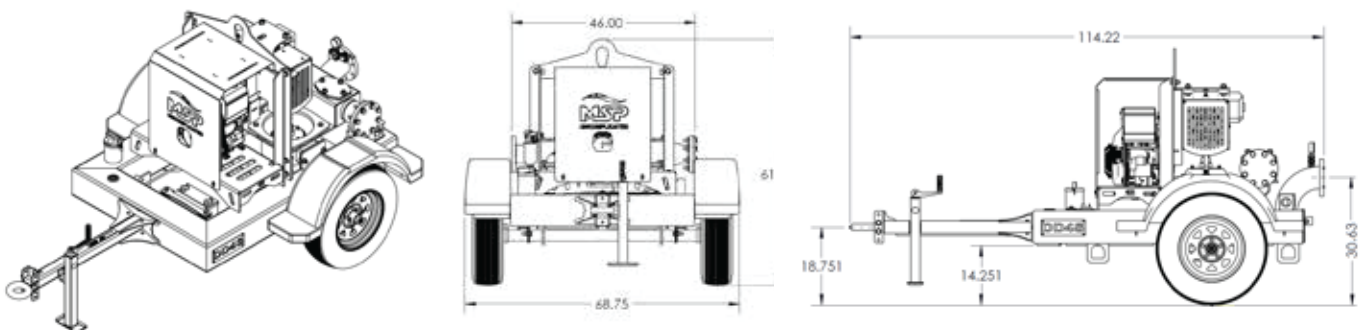

SOLD BY

Myers-Seth Pumps | goodpeople@msp-pumps.com | 4611 Dignan



AQUOSIS
FLUID SOLUTIONS

info@aquosis.com
1.877.907.7852