

# BESTRONG

 bestrongworld  bestrongworld  usa.bestrong.com  usa@bestrong.com

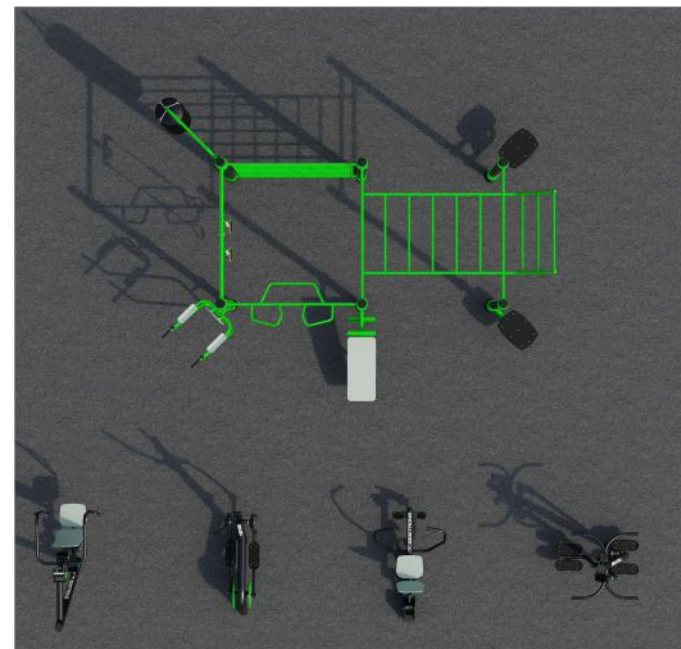

## FitLiving 3

Transform your residential complex into a hub of wellness with FitLiving 3 Outdoor Fitness Park. Designed to promote an active lifestyle among residents, this exceptional outdoor facility offers a comprehensive range of exercise equipment. From cardio to flexibility training, FitLiving 3 provides a versatile and inviting space where residents can prioritize their fitness and overall well-being.

## Attributes

Product code	1-3-252
Certificate	EN 16630, ASTM F3101
Age group	14 + years
Designed for	Residential Complexes
Capacity	24 people
Fall height	4.6 ft

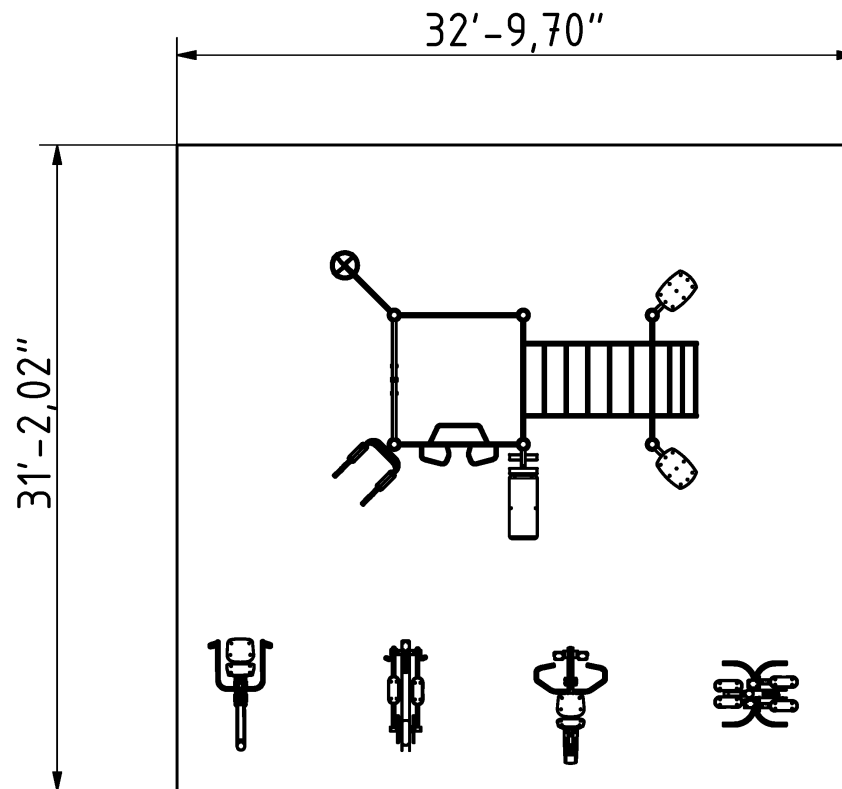

## Technical specification

Anchoring option  
 Net weight  
 Material  
 Anti-corrosion possibility  
 Total Area  
 Color options  
 For more color options, discuss with your sales representative.

In-ground or surface  
 1951 lbs  
 S235  
 Galvanized or EPD  
 1022.2 ft<sup>2</sup>



## Warranty

Structure  
 Steel  
 Paint  
 Plastic  
 Rubber  
 Moving parts  
 Detailed information in the warranty document

25 years  
 15 years  
 2 years  
 5-10 years  
 1-3 years  
 2 years