

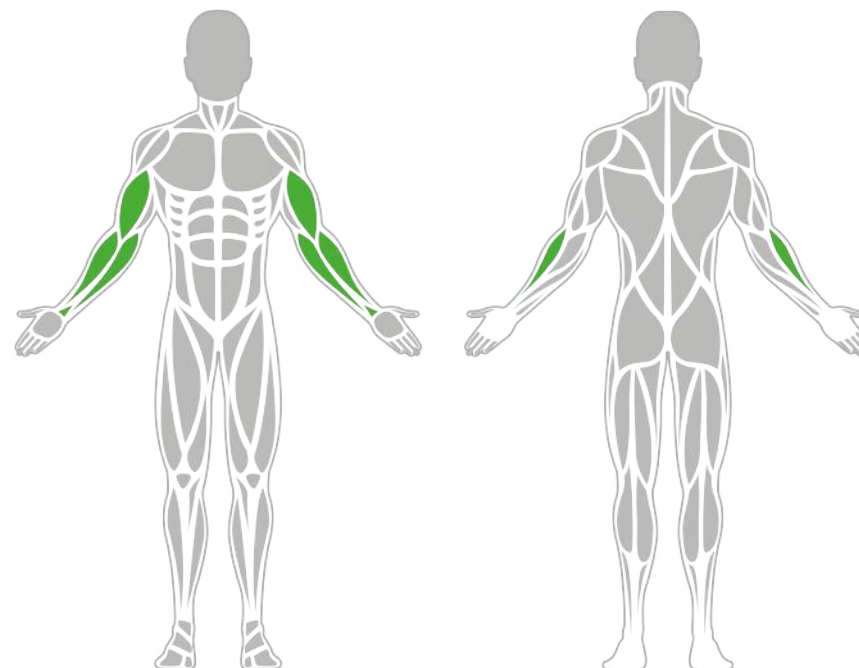

Muscle Groups Focus



Weighted Bicep Curl

The BESTRONG Weighted Bicep Curl is ideal for those looking to strengthen and shape their biceps muscles. With adjustable resistance ranging from 3 kg to 53 kg, it offers a challenge for everyone from beginners to advanced users. The machine's stable and robust construction ensures a safe workout. Its minimalist design makes it easy to use, making it an ideal choice for those seeking a simple yet effective tool for their biceps workout.

Attributes

Product code	1-1-321
Certificate	EN 16630
Age group	14 + years
Capacity	1 person
Max. weight load	130 kg
Type	Weighted
Difficulty level	Adjustable

Side View

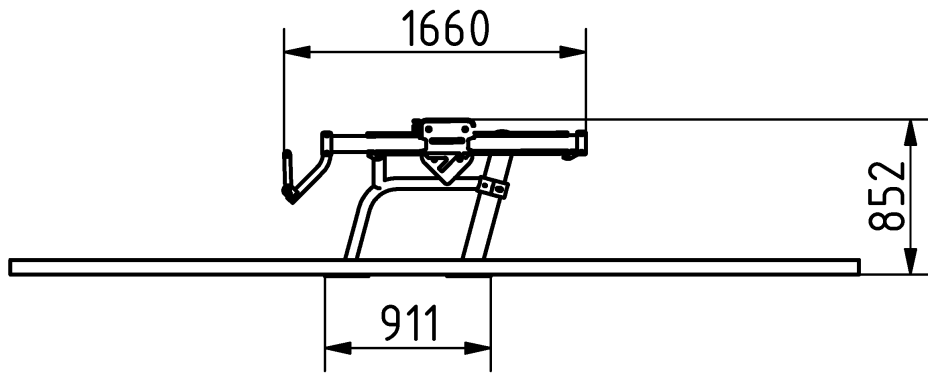

Plan View

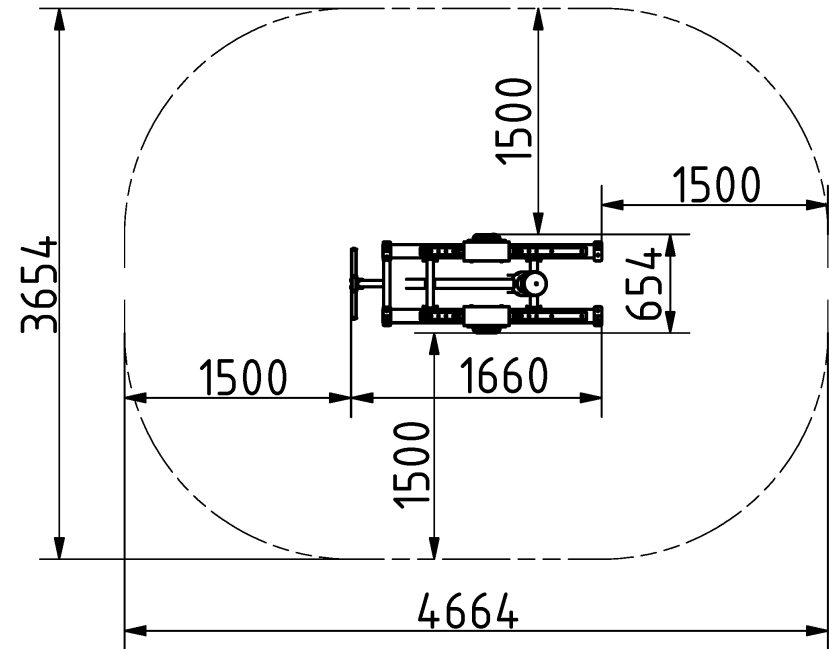

Installation information

Number of installers (concrete)	At least 2 people
Total installation time (concrete)	80-140 min.
Number of installers (equipment)	At least 2 people
Total installation time (equipment)	60 min.
Excavation volume	0.54 m ³
Concrete volume	0.4 m ³
Size of the base structure	1 x 0.5 x 0.8 m
Anchoring options	Surface mounted
In combined structures, the volume of concrete required varies.	

Technical specification

Safety surface area	Around 1,5 m radius
Net weight	199 kg
Material	S235,S355,KO33,HDPE
Critic fall height	-
Color options	● ● ● ● ● ●
For more color options, discuss with your sales representative.	

Warranty

Structure	25-15 years
Steel	5-10 years
Paint	2 years
Plastic	5-10 years
Rubber	1-3 years
Moving parts	2 years
Detailed information in the warranty document	

Material specification



The element is made of high quality S235 steel, which has been cleaned via sandblasting. A corrosion resistant powder coating finish is then applied. Also available with galvanized surface for even greater protection and longevity!



The bumpers of the devices are made of durable rubber material.

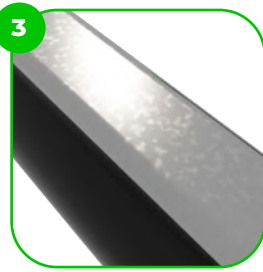

The sliding weight rail is made of high-quality stainless steel, which guarantees the product's long-term durability and resistance to weathering.



The device is fitted with composite bearings that are weather-resistant. The bearing does not require regular maintenance.



The device is equipped with two 40 kg weights, which allow you to perform workouts of varying intensity.

