

STADIUM & SPORT HALL



ويفز للتجارة والمقاولات ك. م. م .
WAVES TRADING & CONTRACTING W.L.L.



www.waves-qatar.com





STADIUM SERIES

WELCOME TO OUR STADIUM SERIES

In our factory we have our own plastic injection machine to produce stadium plastic chairs.

As well Waves SeatUpEurope[®] has much more to offer you: We develop VIP Seats for Stadium and sport salons and these models are serving Important and fancy sports clubs in Europe and around the world.

As well recently we became a main role in europe and in the middle east for the production of telescopic seating systems and portable seating system.

Thanks to the metal section in our factory which has been extended for that purpose.has been extended for that purpose.

STADIUS 220





General Features

- Producing according to ISO 9001:2008 management system.
- Our products stand the standards of: V2-UL94 (Flammability), ISO4892-2 (Ultraviolet) and TSEN12727 (Unbreakable).
- All the metal parts that are in use in our products are: TS EN 10204 3 / 1 standard.
- We only use original raw materials during the producing process.
- In order to provide maximum protection from sun light in outdoor and lights in indoor we use: Ultraviolet stabilizer.
- We only use high quality colors in order to avoid fading of Colors as result Of exposure to sunlight or other lights.
- The structure of the back and the seat of our seats is built as orthopaedic In order to avoid uncomfortable feeling while sitting for long time.
- As a result of using original raw materials with high quality our stadium seats always looks shiny and have live color.
- Our stadium chairs have 4 mounting points and for each point there is hard plastic cover for protection and for esthetic.
- In the center of our stadium chairs there is a canal that will collect out water in a case of rain or humidity and therefore the chair will stay dry rather if it's located in indoor or outdoor area.

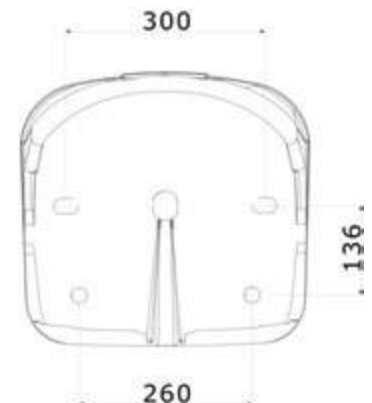
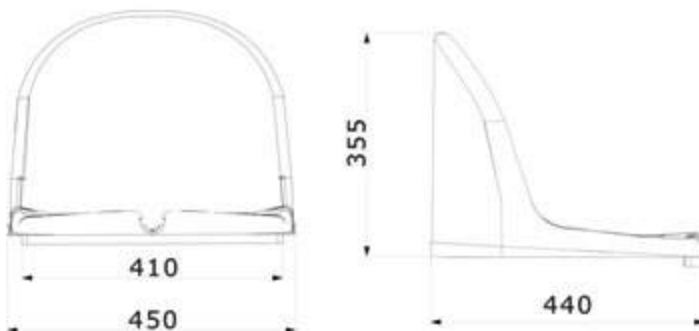
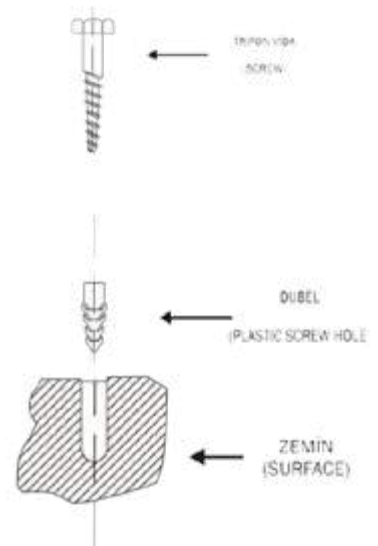





STADIUS 111



100	Ø 10x10	10x10
100	10x10	10x10
2 Adit 2 Pieces	2 Adit 2 Pieces	2 Adit 2 Pieces

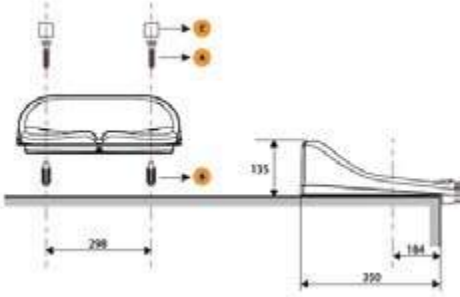



STADIUS TIP-UP 401





General Features

- The stadium seats will be produced by polythene or polypropylene materials which have high-strength values.
 - In raw material doesn't have non-standard (scrap) and weighting material filler.
 - UV stabilizer for protective purposes and paint to prevent discoloration to be added in the raw materials which will be used to production folding stadium seat on request.
 - Maximum-resistant paint is used to against the light.
 - Production is carried out according to ISO 9001:2008 quality management system.
 - Due to the use of the original raw materials, our stadium seat colors are bright and vivid.
 - 4 Point made easy mounting provides the necessary rigidity.
 - With the metal washers on the mounting points and relaxation resistance to breakage is increased
- STADIUS 401
- Certainly not on the water bar.
 - On the seat through the discharge channel, the water would drain at the bottom rung of chairs.
 - Back and legs that will not disturb the structure and orthopedic seating is capable of.
 - In line with customer demand; Ultraviolet Stabilizers spiked, fire retardant additive, light of sensitivity, impact resistance against high product can be produced.

Note: The STADIUS 401 model can be produced with many versions and with combination between the versions such as : -with upholstery, -with armrest, -with writing table, with fixing legs to the floor, with fixed method to floor, and more.

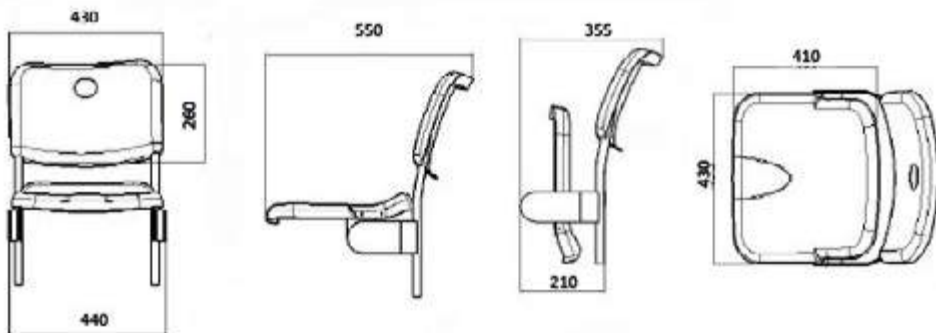

STADIUS TIP-UP 401

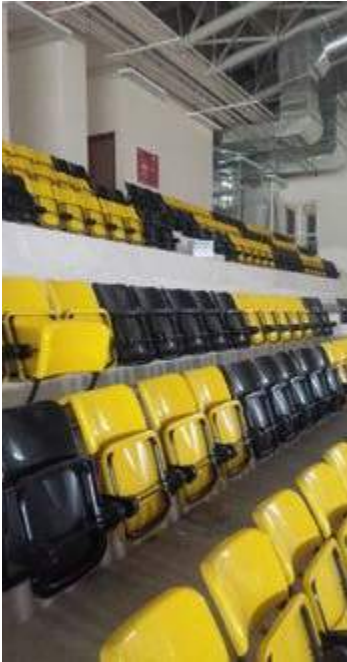



STADIUS TIP-UP 401



STADIUS 401 with upholstery





STADIUS 401 with armrest and table

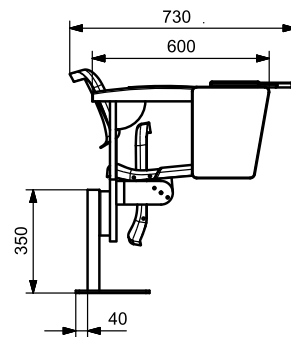
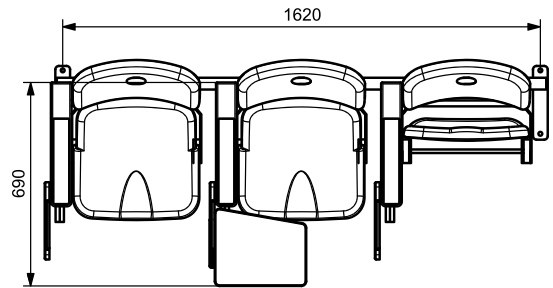
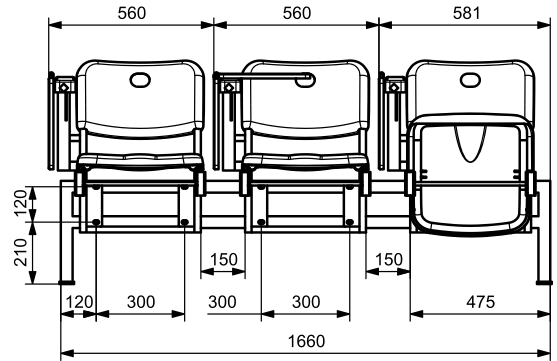

VIP SEATUP2 ANTI PANIC





- Product has certified according to TS EN 12727.
- Seatrest and backrest frame are steel construction and are covered by foam at the density of 50 ± 5 (kg/m^3) in special aluminium moulds.
- Framed seatrest and backrest foam surfaces are upholstered with desired fabric, leather or artificial leather.
- Armrest structure is manufactured by aluminium, armrest is manufactured by ABS plastic material.
- Armrests have antipanic feature. When user stands up from sitting position, backrest and armrest are closed together.
- When armchair is closed, it occupies as armrest carcass width and leaves a wide usage area for user at the passing area.
- Product is covered by nylon and packed into cartoon box.

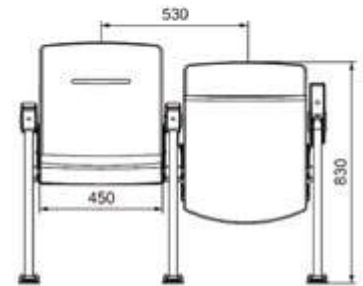
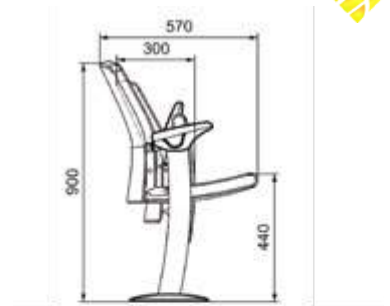

Note: This model can be produce with many versions such as : - fixing to stairs, fixing to floor with 2 legs and for Telescopic systemes.



PLAYER SEAT

We are producing varieties of player seats including the bench and the Shelter construction with unbreakable and Anti UV fiber glass roof.

Models can be custom made.





NEW PRODUCT

BLOW MOLDING SEATS

For stronger and extra durability performance we present our new Blow Molding Stadium Seats.









TELESCOPIC SYSTEM

**WELCOME TO OUR
TELESCOPIC SYSTEM**

 www.waves-qatar.com

TELESCOPIC SYSTEMS

The purpose of this technical specification; Telescopic Grandstand will be used for the manufacture of all kinds of devices, equipment and grandstands national and / or international standards to ensure the safety of life and property in accordance with the principles of determining the arrangements to be made. According to the static calculations and architectural design of the project which will be the statistical value of the steel material to be used in the system in the(TSE EN 10219-2) standard; steel material is used. Lightweight Galvanized, specially formatted perforated U-profile are the main carrier of the profile systems with ST37 boxes manufactured, all along has been developed together with coarse and fine products.

TELESCOPIC GRANDSTAND FEATURES

Telescopic grandstands total 3 and Platform 4 will consist of ordinary. Width for Platforms starting from the Ground will be 80 cm, Width only for the bottom Platform will be 125 cm. When the Telescopic Grandstands are open it will be 285 cm. When the Telescopic Grandstand closes, the Platforms will hide into the last Platform and will cover 100 cm space.

PLATFORM AND CARRIER FRAME FEATURES

Skeleton of the platform in the manufacturing of 2 mm galvanized sheet metal bent in special forms and sizes ISO 1461/1999 (E), DIN EN 1461 standard perforated sheet metal to be used.

Only in the vertical and horizontal carrier box profile will be used. When they are joined with other carriers rivet welding will not be used.

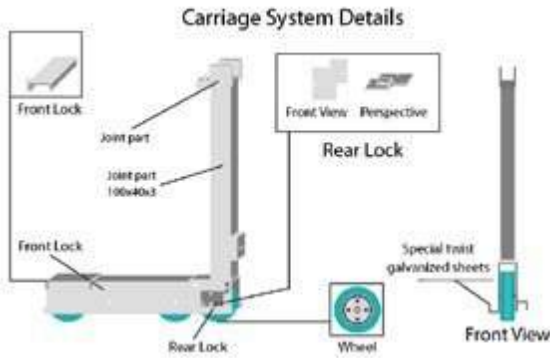

Quick and most cost effective way to fix any faults that may arise later it will be attached with bolts and nuts. Welding will not be used in anyway on the skeleton of the Platform. Welding will only be used on the connection of platform and the electric motor.

Carrier Platform U Profile

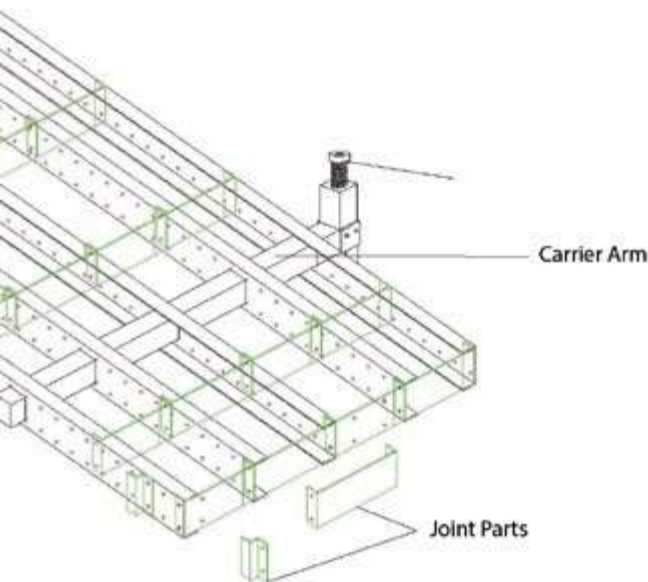
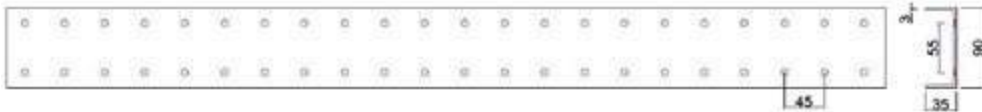

Materials used for the manufacture of the Telescopic Grandstand and railings are below;

- Pipes DIN 2394
- Box Profiles DIN 2395
- Lama (Metal piece) DIN 1016

Gas Metal Arc Welding will be used for the manufacture of the Structure. Welding method-da DIN 8559 - AWS 5, BS EN 288 Part 3 1988 Standards will be applied. Wire used ill meet SG2 standards.

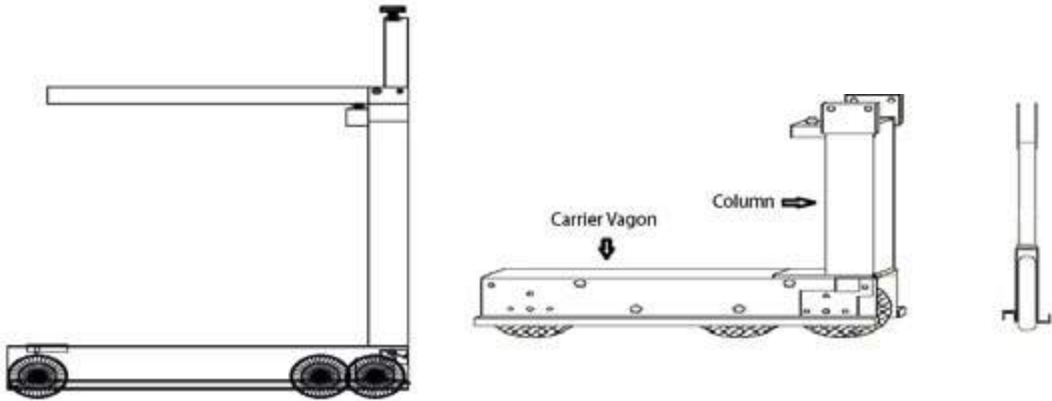

THE SCARECROW AND THE ESTABLISHMENT OF THE BARS:

For the installation of Railing, should be placed on its side, using screws as shown in the illustration every railing should be mounted onto a platform.

Bolts must be placed as shown in the image.

Supporting structure and railing shall be coated with hot dip galvanizing method.

SHUTTING DOWN PLATFORMS AND THE STAIRS

Platform and the stair will be covered with 12mm Thick Polywood. 2 mm thick acoustic PVC floor tile will be applied ontop. The stairs will be in 100x33 cm min.





WHEELS

The carrier wheels to be used will be selected according to the nature of the area. Wheel diameter \varnothing 150x45 mm, carrying capacity 500 kg per wheel.

ELECTRIC MOTOR

For the movement of the Telescopic Grandstand the Electric Motor will be mounted onto the first Platform. Control button will also be attached for the Platform to move back and forward. Roulette will be carried out by human power or electric motor, product to absorb the reaction forces that could shock absorber in terms of roulette-type will be selected. The wheels on the wagon bobbins that connects the din5401, Heat 1086 will meet normal standard.



We are developing and producing varieties of VIP seats that can be used for telescopic systems.

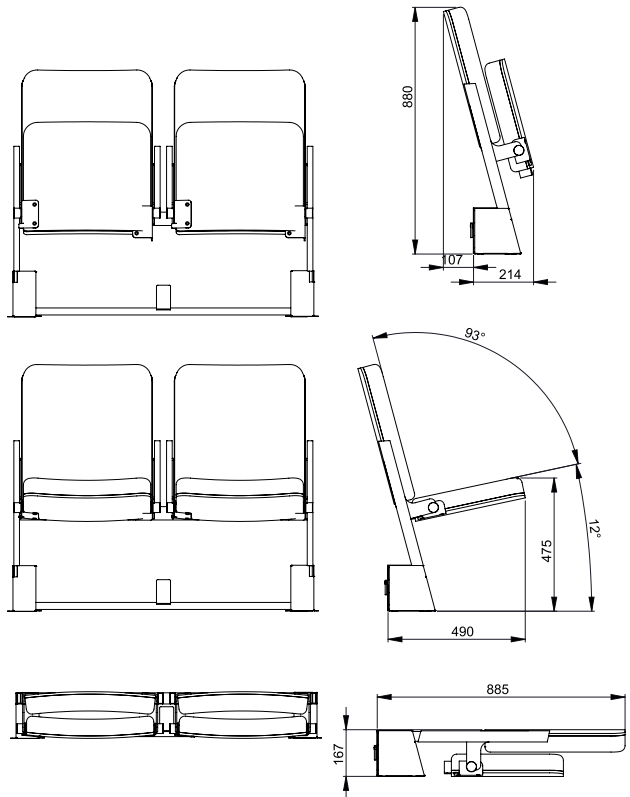

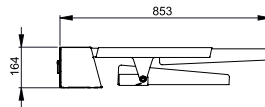
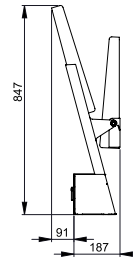
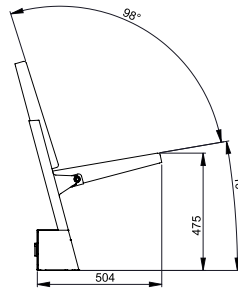
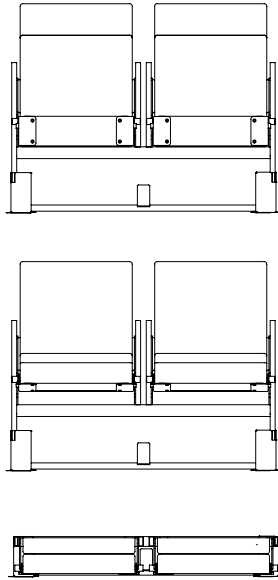







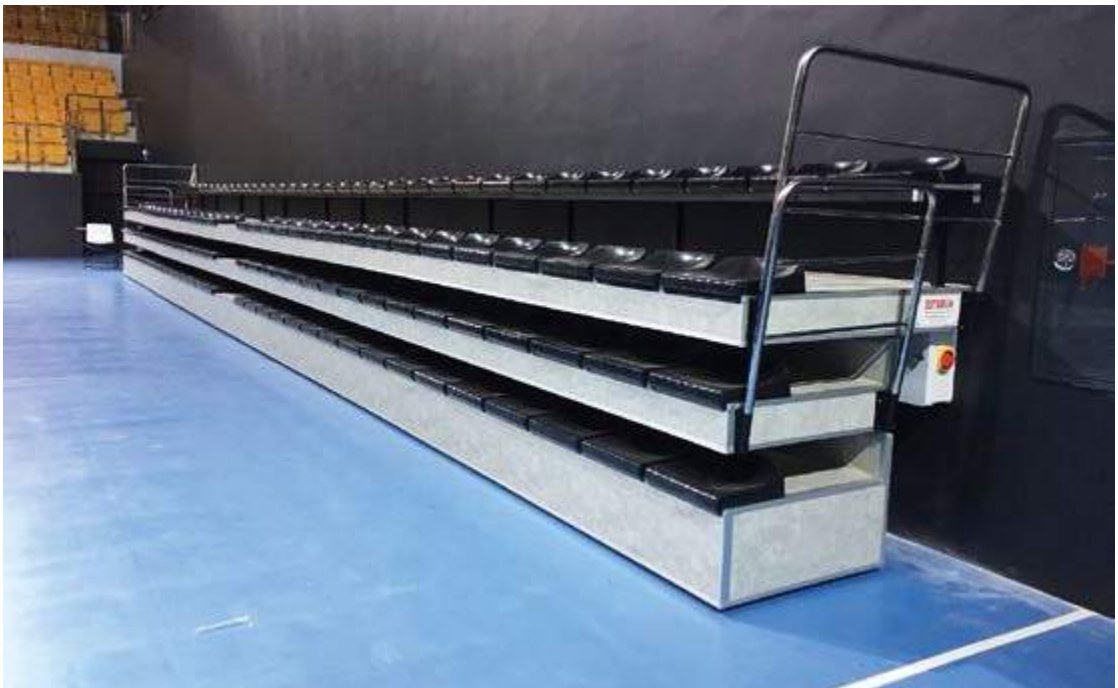

TELESCOPIC TRIBUNE INSTALLATION GUIDE

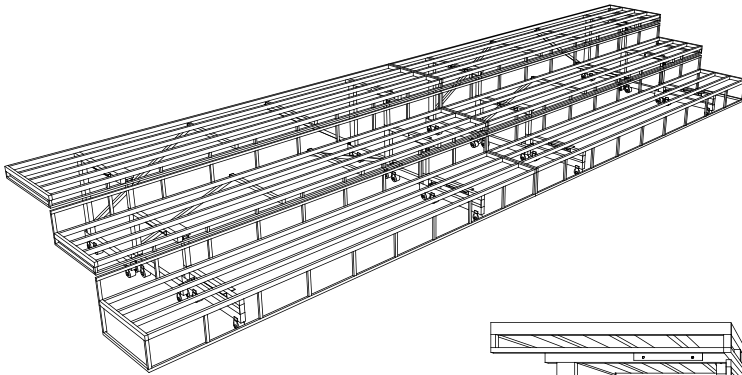
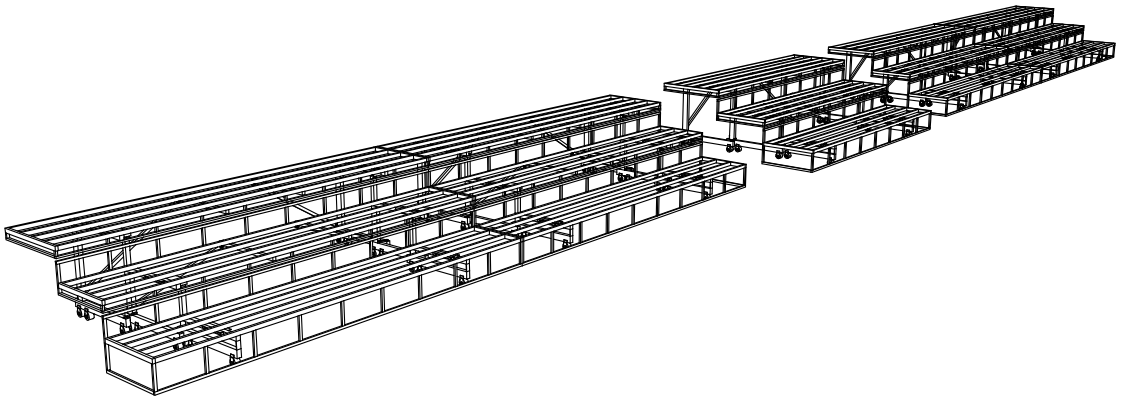

TELESKOPIK FRONT AND FRONT SIDE ISOMETRIC APPEARANCE

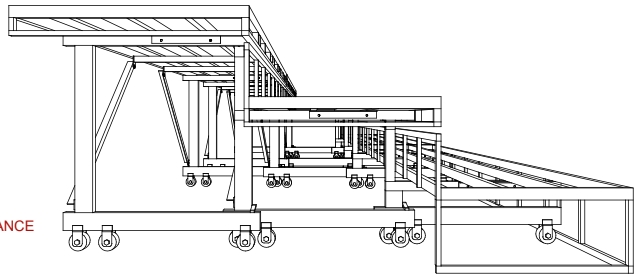

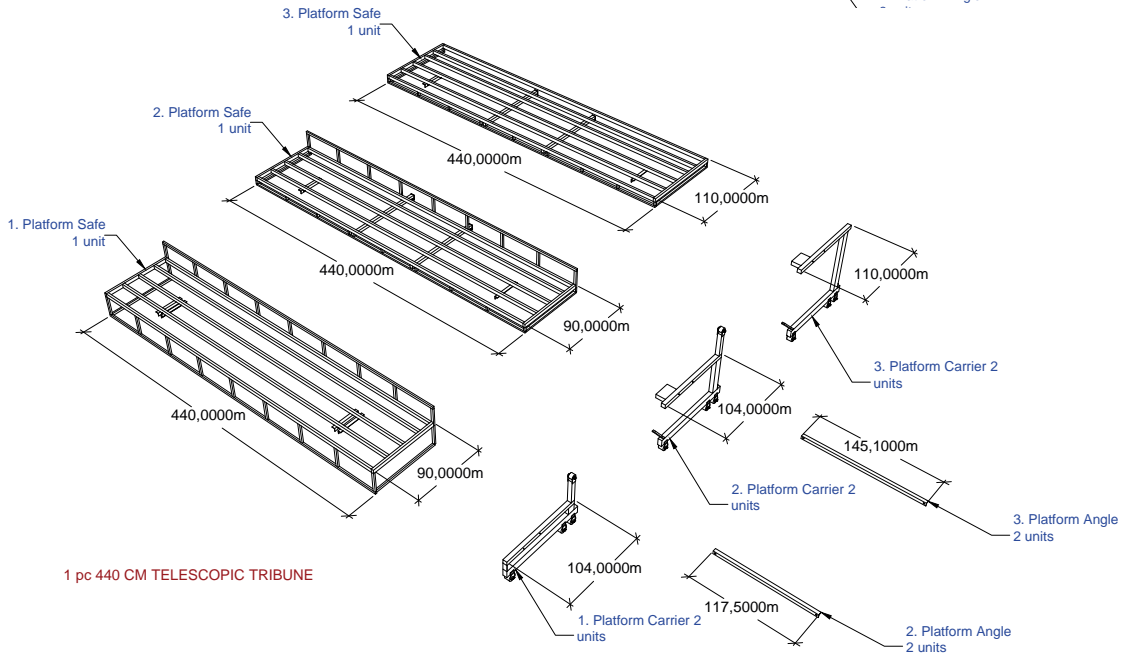
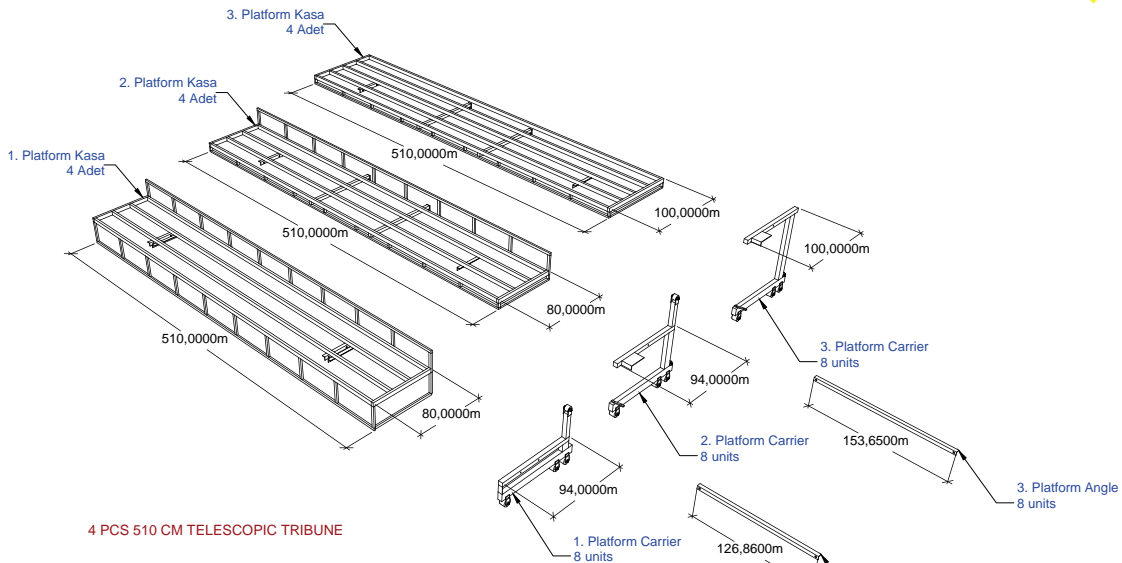

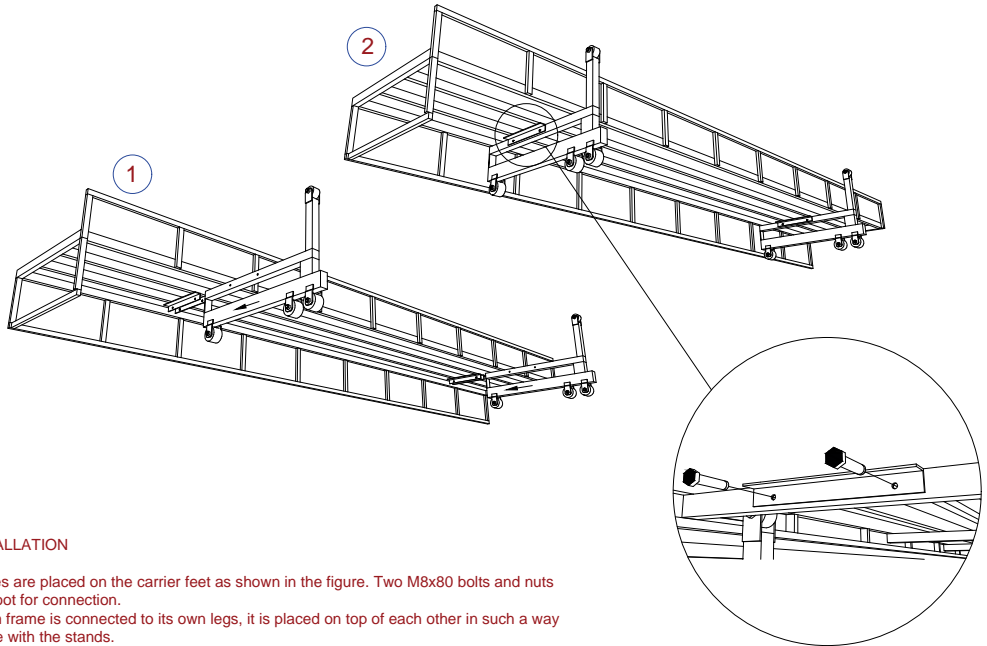

PLATFORM INSTALLATION

The platform frames are placed on the carrier feet as shown in the figure. Two M8x80 bolts and nuts are used at each foot for connection. After each platform frame is connected to its own legs, it is placed on top of each other in such a way that it stands in line with the stands.

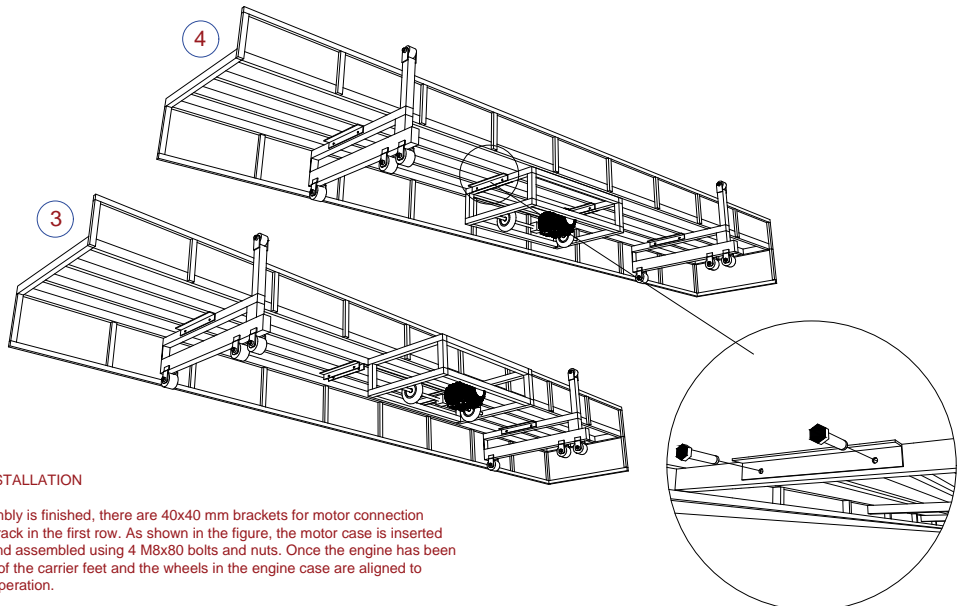

ELECTRIC MOTOR INSTALLATION

After the platform assembly is finished, there are 40x40 mm brackets for motor connection between each platform rack in the first row. As shown in the figure, the motor case is inserted between the brackets and assembled using 4 M8x80 bolts and nuts. Once the engine has been assembled, the wheels of the carrier feet and the wheels in the engine case are aligned to ensure proper system operation.



5

CLAY PLATFORM ASSEMBLY

Two independent 510 cm platforms are mounted to each other with the help of bolts and nuts M8x80 through the mounting holes in each step as shown. In this way, the two platform platforms are prevented from moving independently of each other.

6

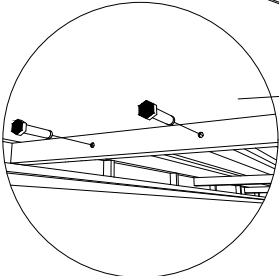

7

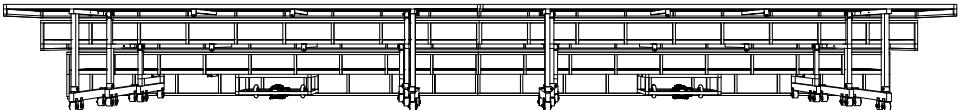

8

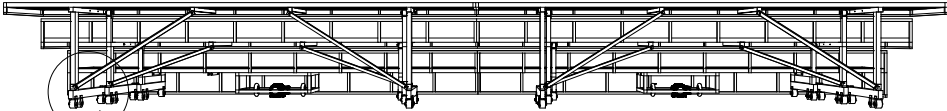

9

CONNECTION LAMPS

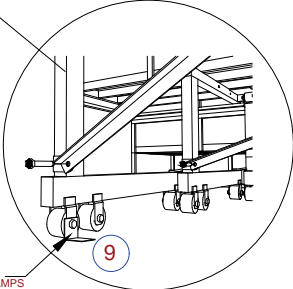

CORNER ASSEMBLY AND FIXATION

Each carrier is connected to the connecting flanges at the rear of the foot and in the middle of the 2nd and 3rd row platform casings as shown by 40x40 mm brackets. M14x30 bolts are used for connection. After the specified assembly process is finished, it is placed in the field where the tribune is used and fixed at the place. Twisted L-shaped connecting brackets are used to secure them in place. As shown in the figure, L is mounted on one side with bolts in the rear wheel and on the other side with steel dowels, fixing is done.

SEAT INSTALLATION

There are 192 different PVC seats and 18 different VIP seats. PVC seats are assembled in four groups as shown in the layout chart below, with 48 being one. There is only one group for 18 VIP seats.
 The seat assembly is also made with the attachment markings on both seat versions. The connecting plates come out of the package with one side mounted on the seat. The other part, which is empty, is equally spaced so as to correspond to the wooden part of the platform frame.

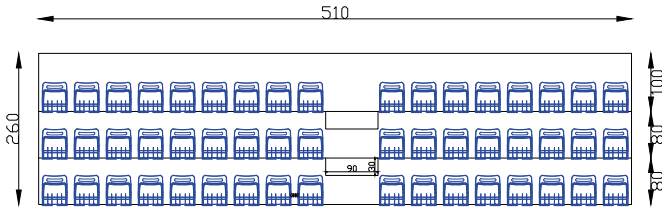

48 UNITS SEAT MODEL STADIUS111 - 4 GROUP

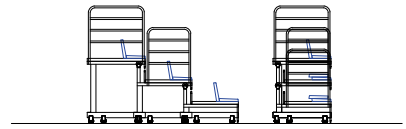

10

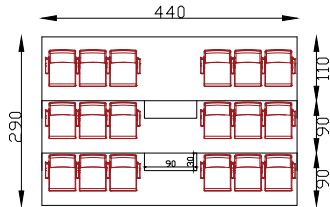

18 UNITS VIP SEATS - 1 GROUP

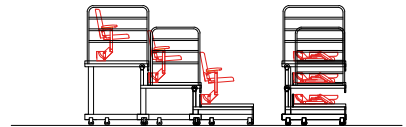

ELECTRIC PANEL CONNECTION SCHEME

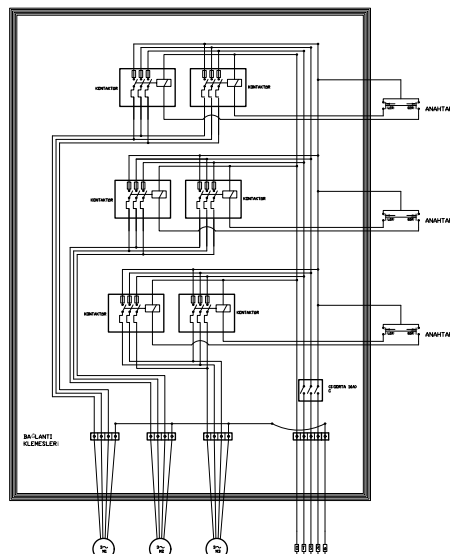



TELESCOPIC TRIBUNE USE INSTRUCTION

- Be sure to read the operating instructions before operating the platform!
- You provide environmental safety for the platform.
- Open the cover of the telescopic tribune electric panel and remove all the fuses inside.
- Check whether the telescopic tribune electrical panel is receiving electrical power from the light sensors on the panel.
- The platform is moved on the electric panel using the forward and back buttons.
- As long as the platform is moved forward (to open the platform), the platform stops and stops when the forward button is held down, and stops when the back button is pressed to hold back the platform.
- When the platform moves forward or backward, close all the fuses in the electric panel and do not forget to close the cover of the electric panel.

WARNING

- Other than the technical officers, interference with the electric system is PROHIBITED. HIGH VOLTAGE INCLUDED!
- During the opening or closing processes of the telescopic tribune, there shall be no substance or person on, under, in front of or around it.
- The maximum capacity of the telescopic tribunes is 210 persons. Exceeding the capacity is DANGEROUS and PROHIBITED!
- The telescopic tribunes must be fully open or fully closed. Half-open use is DANGEROUS and PROHIBITED!

PROTABLE SYSTEM MINI STADIUM



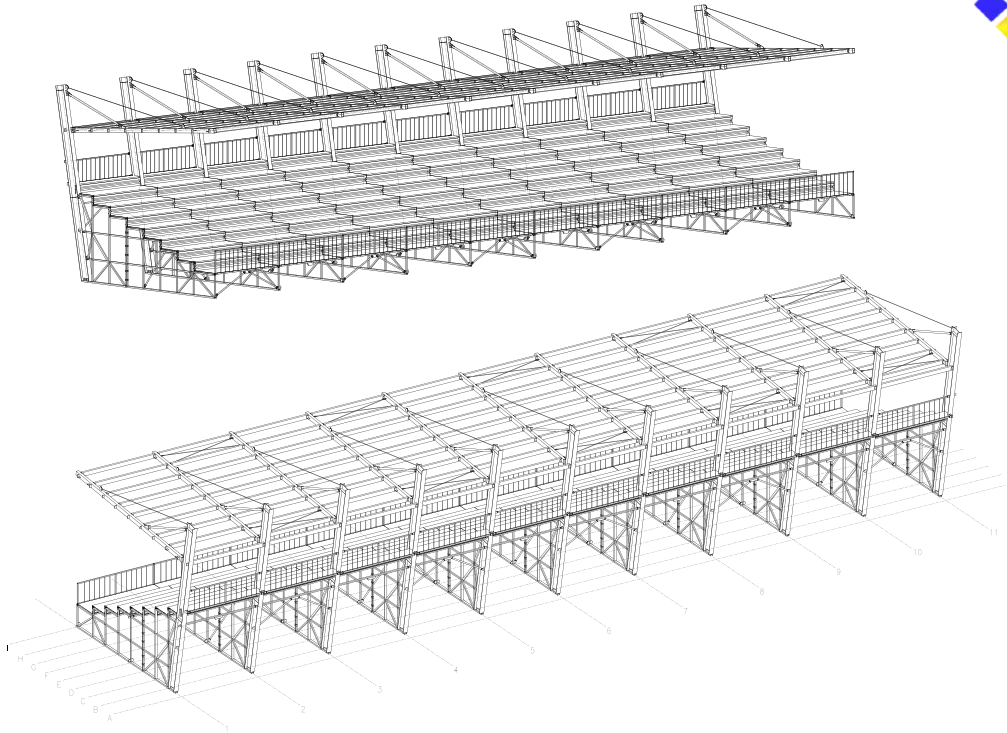

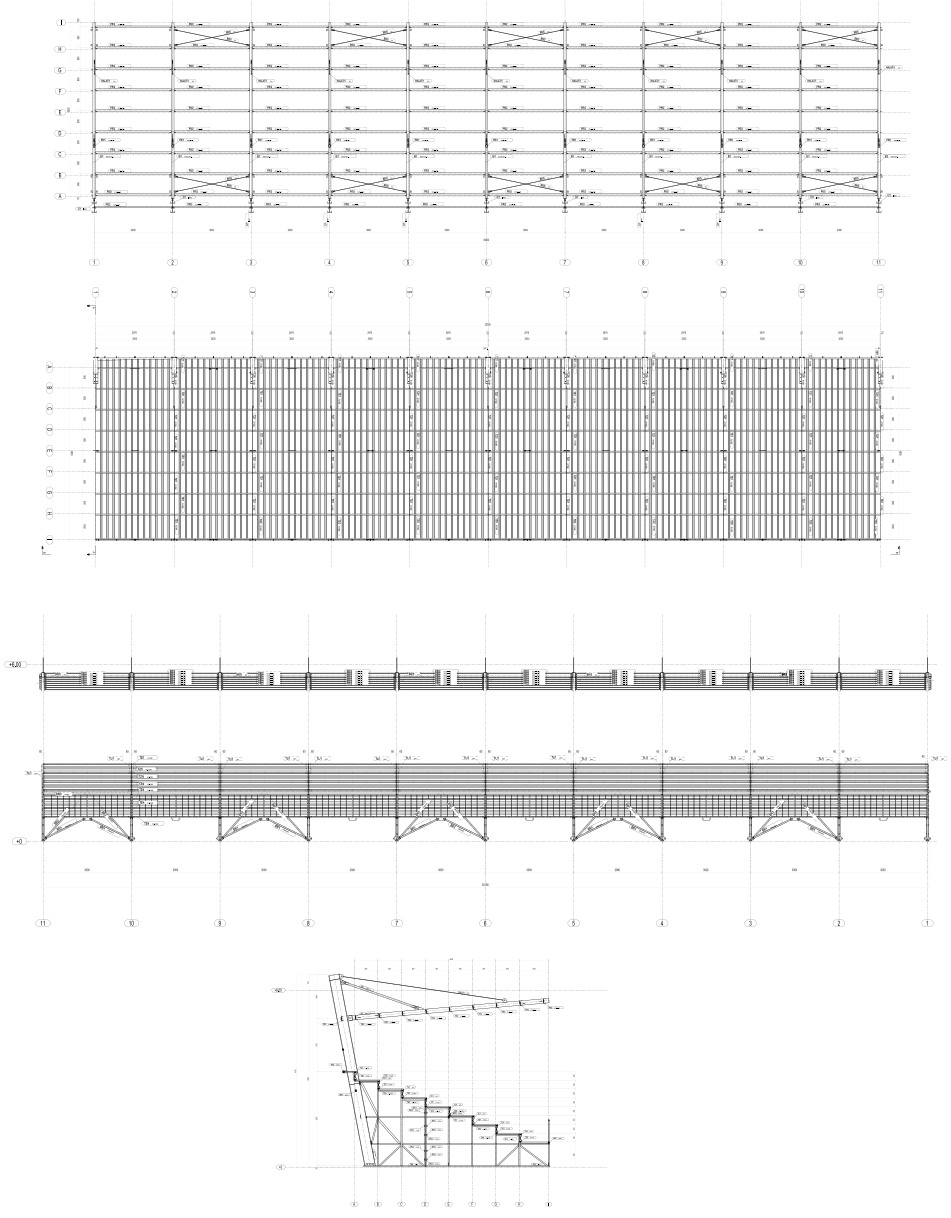

PROTABLE SYSTEM MINI STADIUM



www.waves-qatar.com



**Waves Seatup Europe | Manufacturing Seating Solutions
Catalogue 2020 - 2021**



ويفز للتجارة والمقاولات ك.م.م . WAVES TRADING & CONTRACTING W.L.L.

6th Floor, Building No:24,
Zone: 26, Street No: 940,
Al Najma, Doha, Qatar
P.O.Box : 82431 Doha, Qatar

Tel : +974 4441 6319
Fax : +974 4441 6312
info@waves-qatar.com
www.waves-qatar.com