



VILLANOVA

C O L L E G E

COURSE CALENDAR

GRADES 9-12

2026 - 2027

TABLE OF CONTENTS

INTRODUCTION	6
VILLANOVA COLLEGE	6
OVERALL GOALS AND PHILOSOPHY OF EDUCATION	6
MISSION AND VISION.....	6
COURSE CALENDAR	6
SCHOOL ORGANIZATION	7
SCHOOL LEADERSHIP.....	7
SCHOOL SCHEDULING.....	7
CODE OF CONDUCT	8
STUDENT CODE OF HONOUR	8
ACCEPTABLE USE OF TECHNOLOGY STUDENT AGREEMENT	9
ATTENDANCE	9
EXTENDED STUDENT ABSENCE FROM SCHOOL	10
ACADEMIC ETHICS	10
ACADEMIC INTEGRITY	10
CHEATING.....	10
PLAGIARISM.....	11
MISSED WORK	11
LATE ASSESSMENTS	11
TEST CENTRE.....	12
SAFE SCHOOL POLICY	12
BULLYING	13
HAZING.....	15
SMOKING AND VAPING.....	16
DRUGS AND ALCOHOL.....	16
DIPLOMAS AND CERTIFICATES	17
THE VALUE OF AN ONTARIO SECONDARY SCHOOL DIPLOMA	17
DEFINITION OF A CREDIT.....	17
COMPULSORY CREDIT POLICY	17
ONTARIO SECONDARY SCHOOL DIPLOMA (OSSD)	17
<i>Students who started Grade 9 in 2023 or prior</i>	18
<i>Compulsory Credits (Total 18)</i>	18
<i>Optional Credits* (Total of 12)</i>	18
<i>Additional Course Requirements</i>	19
<i>Students who started Grade 9 in 2024 or after</i>	19
<i>Compulsory Credits (Total 17)</i>	19
<i>Optional Credits* (Total of 13)</i>	19
<i>Additional Course Requirements</i>	20

REQUIREMENTS FOR THE ONTARIO SECONDARY SCHOOL CERTIFICATE*	20
<i>Compulsory Credits (Total of 7)</i>	20
<i>Optional Credits (Total of 7)</i>	20
THE CERTIFICATE OF ACCOMPLISHMENT*	20
VILLANOVA COLLEGE DIPLOMA	20
COMPULSORY NON-CREDIT REQUIREMENTS OF THE OSSD	21
THE ONTARIO SECONDARY SCHOOL LITERACY TEST (OSSLT)	21
FINANCIAL LITERACY	21
COMMUNITY INVOLVEMENT.....	21
<i>Eligible Activities for Community Involvement</i>	22
<i>Ineligible Activities for Community Involvement</i>	22
CHRISTIAN SERVICE AT VILLANOVA COLLEGE	23
ALTERNATIVE WAYS OF EARNING CREDITS.....	23
E-LEARNING	23
PRIOR LEARNING ASSESSMENT AND RECOGNITION (PLAR).....	24
EQUIVALENCIES.....	24
CHALLENGE	24
MUSIC CERTIFICATES ACCEPTED FOR CREDIT	24
REACH AHEAD CREDITS	25
STUDENT ACHIEVEMENT	25
COURSE SELECTION	26
THE ORGANIZATION OF SECONDARY SCHOOL COURSES	26
ACADEMIC RIGOUR	27
SYLLABUS.....	27
ACCESS TO ONTARIO CURRICULUM DOCUMENTS	27
EXPLANATION OF COURSE CODES.....	27
CHANGING COURSE TYPES	27
GRADES 9 AND 10	28
<i>De-streamed (W)</i>	28
<i>Academic Courses (D)</i>	28
<i>Open Courses (O)</i>	28
<i>Grade 9 Course Selection</i>	28
<i>Grade 10 Course Selection</i>	28
GRADES 11 AND 12	29
<i>University Preparation Courses (U)</i>	29
<i>University/College Preparation Courses (M)</i>	29
<i>Open Courses in Grades 11 and 12 (O)</i>	29
<i>Grade 11 Course Selection</i>	29
<i>Grade 12 Course Selection</i>	30
VILLANOVA COLLEGE COURSE SELECTION PLANNING CHART	30
ADVANCED PLACEMENT	31
WHAT IS THE AP PROGRAM?	31
AP SELECTION CRITERIA	31

THE EXAM	32
AP COURSE DESCRIPTIONS	32
STEM.....	37
WHAT IS STEM EDUCATION?	37
WHAT ARE THE BENEFITS OF STEM?	37
THE STEM PROGRAM	37
STEM SELECTION CRITERIA	37
VILLANOVA COLLEGE STEM COURSE SELECTION PLANNING CHART	38
THE ONTARIO STUDENT TRANSCRIPT AND AP AND STEM COURSES.....	38
STEM COURSE DESCRIPTIONS.....	38
SUPPORT FOR STUDENTS	42
THE TEACHER-ADVISOR AND GUIDANCE COUNSELLING	42
GUIDANCE AND CAREER EDUCATION	42
BALANCED CURRICULUM	42
CLASS SIZE	42
TECHNOLOGY LAPTOP PROGRAM	42
TUTORIALS	43
INTERVENTIONS	43
SUPPORTS FOR ENGLISH LANGUAGE LEARNERS	43
SPECIAL EDUCATION ACCOMMODATIONS	43
STUDENT SERVICES POLICIES & ACCESS TO INFORMATION	44
SUBSTITUTIONS FOR COMPULSORY CREDITS	44
WAIVING PREREQUISITES.....	44
COURSE SELECTION & COURSE CHANGES	44
NON-VILLANOVA COLLEGE CREDIT POLICIES AND PROCEDURES	45
ONTARIO STUDENT TRANSCRIPT (OST).....	45
ONTARIO STUDENT RECORD (OSR).....	46
VILLANOVA COLLEGE SUMMER SCHOOL	47
SUMMER SCHOOL PROGRAM 2026	47
SUMMER UPPER SCHOOL ACADEMIC CREDITS.....	47
UPPER SCHOOL SUMMER COURSE OFFERINGS.....	47
<i>Grade 9</i>	48
<i>Grade 10</i>	48
<i>Grade 11</i>	50
<i>Grade 12</i>	50
ENGLISH AND MATH SKILLS DEVELOPMENT PROGRAM FOR MIDDLE SCHOOL STUDENTS	50
COURSE DESCRIPTIONS GRADES 9-12.....	51
THE ARTS	51
BUSINESS STUDIES.....	54
CANADIAN AND WORLD STUDIES	56
CLASSICAL STUDIES AND INTERNATIONAL LANGUAGES.....	59
COOPERATIVE EDUCATION	60
COMPUTER STUDIES	61

ENGLISH	62
ENGLISH AS A SECOND LANGUAGE AND ENGLISH LITERACY DEVELOPMENT	64
FRENCH AS A SECOND LANGUAGE	66
GUIDANCE AND CAREER EDUCATION	68
HEALTH AND PHYSICAL EDUCATION	69
INTERDISCIPLINARY STUDIES	71
MATHEMATICS	72
RELIGIOUS EDUCATION.....	74
SCIENCE.....	76
SOCIAL SCIENCES AND HUMANITIES	78
TECHNOLOGICAL EDUCATION	79
PREREQUISITE CHARTS.....	80
THE ARTS (2010), GRADES 9-12	80
BUSINESS STUDIES GRADES 9-10 (2024), GRADES 11-12 (2006)	82
CANADIAN AND WORLD STUDIES, GRADE 9 (2024), GRADE 10 (2018) AND GRADES 11 AND 12 – GEOGRAPHY (2015)	84
CANADIAN AND WORLD STUDIES, GRADES 9 AND 10 (2024) AND GRADES 11 AND 12 – HISTORY	85
CANADIAN AND WORLD STUDIES, GRADES 9 AND 10 (2024) AND GRADES 11 AND 12 – ECONOMICS, LAW, AND POLITICS.....	86
CLASSICAL STUDIES AND INTERNATIONAL LANGUAGES (2016), GRADES 9-12	87
COMPUTER STUDIES GRADE 10 (2023), GRADES 11-12 (2008).....	88
ENGLISH GRADE 9 (2023), GRADES 10-12 (2007).....	89
ENGLISH AS A SECOND LANGUAGE AND ENGLISH LITERACY DEVELOPMENT (2007)	90
FRENCH AS A SECOND LANGUAGE (2014), GRADES 9-12	91
GUIDANCE AND CAREER EDUCATION GRADE 10 (2024), GRADES 9, 11-12 (2006)	92
HEALTH AND PHYSICAL EDUCATION (2015), GRADES 9-12	93
MATHEMATICS GRADE 9 (2021), GRADE 10 (2005), GRADES 11-12 (2007)	94
SCIENCE GRADE 9 (2022), GRADES 10-12 (2008)	95
SOCIAL SCIENCES AND HUMANITIES (2013), GRADES 9-12.....	96
TECHNOLOGICAL EDUCATION GRADES 9-10 (2024), GRADES 11-12 (2009)	97
NOTES	98

INTRODUCTION

Villanova College

Villanova College is a full-year, non-semestered, Catholic university preparatory school in the Augustinian tradition. All students are expected to maintain a full timetable of eight credits from September to June in each of the first three years at Villanova College. In Grade 12, students are strongly advised to enroll in seven courses but must maintain a minimum course load of six courses.

Overall Goals and Philosophy of Education

Villanova College is an independent, Catholic Augustinian school dedicated to academic excellence and to the enrichment of each student to prepare him/her for university and for a leadership role in society. The school nurtures an environment of faith in spirit and truth in which a caring faculty strives to develop in each student the skills necessary to reach his/her potential. As Christian educators, we firmly believe in these values and endeavour to impart them spiritually, intellectually, morally, and physically.

The secondary school program is designed so that students can meet the diploma requirements in four years following Grade 8. In grades 9 and 10, courses strongly promote the acquisition of essential knowledge and skills by all students. In grades 11 and 12, the program is designed to allow students to choose courses that are clearly and directly linked to their post-secondary aspirations.

Mission and Vision

Our Mission Statement emphasizes the importance of educating the child morally, intellectually, physically, and socially. We offer a variety of extracurricular activities throughout the year to challenge each student to be the best he or she can be. It is our hope that students will participate in as many activities as possible so that they can achieve that goal. It is also our goal to motivate students to strive for excellence in everything they do and with your support we believe that each child will achieve success.

Course Calendar

We have developed this calendar to assist you and your child with the decisions that you will face over the next few weeks. It is our hope that the information provided will help you as a parent to continue to be active in your child's education at Villanova College. We believe that your participation and support are vital to his or her continued success.

The decisions you make with your child in choosing courses are important ones. They will help your child achieve his or her future goals. We encourage you to review this course calendar carefully. If you have any questions, please do not hesitate to contact the Student Services office.

SCHOOL ORGANIZATION

School Leadership

Headmaster	Mr. Paul Paradiso
Head of Upper School	Mrs. Rosalie Naworynski
Dean of Students	Mr. Gianpiero De Rose
Assistant Head of School- Curriculum; Summer School Principal	Ms. Lisa Picerno
Head of Middle School	Ms. Joanne Maritan
Director of Student Services	Ms. Adrienne Gelling
Director of Pastoral Affairs	Mr. Stephen Morris

School Scheduling

Villanova College divides the year into three terms: September to November, December to February, and March to June. The initial Progress Report is in October, followed by three report cards in November, February, and June.

For the 2026-2027 school year, Villanova College will be using a 5-period timetable with an 8-day cycle that tumbles. This schedule will minimize the disruption to any one section with the expansion of school events and activities.

Regular Schedule	Bell Times	Day 1	Day 2	Day 3	Day 4	Day 5	Day 6	Day 7	Day 8
Period 1	8:30-9:35 Morning Announcements 8:30	A	F	C	H	E	B	G	D
Period 2	9:40-10:40	B	G	D	A	F	C	H	E
Period 3a	10:45-11:45 *Grades 9-10 lunch 10:40- 11:20	C	H	E	B	G	D	A	F
Period 3b	11:25-12:25 *Grades 7-8 lunch 11:15-11:45 *Grades 4-6 lunch 11:55-12:25								
Period 3c	11:55-12:25 *Grades 11 and 12 lunch; Grades 4-6 recess								
Period 4	12:30-1:30	D	A	F	C	H	E	B	G
Period 5	1:35-2:35 Afternoon Announcements 2:25	E	B	G	D	A	F	C	H
Dismissal	2:35 2:40 – Bus departures								

Office Hours: 8:00 AM – 4:00 PM



CODE OF CONDUCT

As a Catholic school, Villanova College is required to enunciate a clear Code of Conduct founded on the Gospel teachings of Jesus Christ. The school emphasizes respect for God, staff, students, self and property.

Attending school at Villanova College is done on a voluntary basis by students and is supported by their parents who want them to attend. Villanova College has standards and rules for religious formation, academic achievement, extracurricular participation, and appropriate behaviour. From the day they are accepted into the school until they graduate, all students are bound to obey all rules. **All parents are expected to support the rules.** Parents undertake, by the very fact that they wish to enroll their son or daughter at Villanova College, to give the administration their positive co-operation by ensuring students apply themselves diligently to study, activities, uniform, and the Code of Conduct. This will ensure a positive learning environment for students, staff, and faculty. The rules of the school are contained in the Student-Parent Handbook and in other places or announced to the student body and parents. Students and parents are expected to be familiar with the Student-Parent Handbook.

The Administration of the school reserves the right to change school rules, requirements for admission or graduation announced in the Student-Parent handbook, the arrangement, scheduling, credit or content of courses, the books used, fees charged, tuition charged, regulations affecting students, and to refuse to admit or readmit and to dismiss any student at any time, should it be deemed to be required in the interest of the student or of the school. Registration constitutes a voluntary contract recognized by law between parents and the school. Parents and students assume responsibility for all obligations – religious, academic, and financial, resulting from this contract.

STUDENT CODE OF HONOUR

That I may be educated in an atmosphere of Catholic culture that I may increase in reverence toward God, that I may be courteous toward others and that I may grow in self-control, I have elected to attend Villanova College.

I desire to promote loyalty to my school, to maintain its high standard of honorable conduct, to support enthusiastically all its activities and to make my school a better place for my being one of its students.

That I may make the most of my opportunities to be true to the traditions of my school and to show my appreciation to those who are making my education possible, I hereby make the following resolutions:

That I may assist in its efficient operation, I propose to be obedient to all lawful authority, to study conscientiously and to carry out all the regulations of the school.

I resolve to move quickly and quietly through the school building, doing my part to promote the order necessary in our school.

I will help maintain cleanliness – because cleanliness is next to Godliness – in the school and be vigilant in preventing defacement of the property and buildings.

I determine to follow my program of studies with honest, courageous effort and sincerity of purpose; and be ready to make the personal sacrifices which its successful accomplishment may entail.

In my dealings with others, I resolve to have ambitions and be filled with the strength of worthy convictions. I will regard the property of others as inviolable, eager to render service and quick to appreciate what is done for me. I will be punctual and conscientious in all meetings.

Finally, I resolve, to hold conquest of self as the greatest achievement, remembering that because I am a member of Villanova College, in my keeping is the good name of my school, and I must govern myself accordingly.

A complete code of conduct can be found in the Student-Parent Handbook.

ACCEPTABLE USE OF TECHNOLOGY STUDENT AGREEMENT

Villanova College is committed to providing a high level of information technology resources and facilities in order to provide a secure and effective learning environment.

Students in grades 7-12 will be using their own laptops in all classes. Students are required to have a Windows-based PC laptop that meets the specifications identified by Villanova College. Students are not permitted to use MAC computers at school. MAC computers do not integrate into our Symantec (anti-virus firewall) product, which leaves the entire network vulnerable.

Information technology services are intended for teaching and learning purposes. Access to these services is a privilege granted upon application and retained through responsible use for a student's enrollment at Villanova College. Acceptable use of technology includes practical, ethical and legal use of technology and is governed by School values and standards as outlined in the Student-Parent Handbook and by all relevant statutes, laws and regulations.

Students are responsible for all the content on their laptops/school Chromebook, and all of the content on email and network storage associated with their account, username and password, at all times.

A complete acceptable use of technology agreement can be found in the Student-Parent Handbook.

ATTENDANCE

The Ministry of Education requires that each student complete 110 hours of instructional time in order to be granted a credit at the secondary level. The school's calendar reflects required class time and structured vacation time. Students who miss an excessive number of classes may have their credit withdrawn at the discretion of the Head of Upper School.

Extended Student Absence from School

Vacations are to be scheduled only during the holiday periods as set out by the school calendar each year. Parents are discouraged from scheduling vacation travel outside of those dates. Should parents decide to withdraw their child from school for extended periods of time (in excess of 3 days) for family vacations, they must notify the school in advance, through the Student Services Department. The Student Services Department will require parents to complete the Extended Absence Form, which is available from the Office or in Edsby. Students who are absent from school due to vacations/family trips are:

- responsible for all missed work or notes on their own. Teachers will not be responsible for providing class notes prior to or after the student's absence during vacations outside of the school holiday schedule;
- required to submit all assignments, complete all evaluations and write all tests that are due during the time of their absence prior to their departure or upon their return as determined by the teacher/administration. (Student-Parent Handbook)

Students who fail to meet deadlines due to vacation or other unexcused absences are subject to the late policy as outlined in the Student-Parent Handbook.

ACADEMIC ETHICS

All education includes a moral dimension because human beings are essentially moral animals (Aristotle). In a Christian school this aspect holds an esteemed place. Since Villanova College is a member of the Augustinian family of schools it has adopted *Unitas, Veritas, Caritas* (unity, truth, love), as the values tradition to be passed on to all who come here.

The reality of values-based schools today is that they are often on the front lines, needing to contend with a clash of cultures. The secular culture that is imbibed by the young, usually via the media, applauds getting ahead as the highest value. It glamorizes dishonesty and accepts cheating in order to win or advance one's goals. In this cultural context it is a challenge to form moral and Christian character in the young, but this is part of the educational enterprise.

In order to address each student's moral and Christian education, Villanova College takes seriously the following issues:

Academic Integrity

To act with integrity is to act honestly – adhering to moral and ethical principles. It is an expectation of the school that all students demonstrate academic integrity. A student's work must be a true reflection of his/her accomplishments, hard work, and genuine learning.

Cheating

Cheating in any form is unacceptable behaviour. The dictionary defines cheating as acting dishonestly, practicing fraud. There is no excuse or justification for cheating.

Dishonourable conduct in any form has no place in a Christian academic environment. Quite simply, a student's work must be his/her own, not copied from another author, text, Internet source, or fellow student. Students who aid others in dishonest conduct are also subject to this policy.

The teacher's professional judgment determines whether cheating has occurred.

The following consequences will occur when a student has been involved in dishonourable conduct:

- The teacher will discuss the incident with the student and the Assistant Head - Curriculum.
- The teacher will contact the parents and inform them of the incident.
- The teacher will assign a zero for the academic work or that part of the academic work in question.

Plagiarism

Plagiarism is the act of using another person's ideas or expressions in an evaluative task without acknowledging the source. A breach of the academic ethics code is a serious academic offence and will jeopardize the student's credit and standing in the school. Plagiarism infractions must be reported to the Department Chair and Assistant Head. A student caught plagiarizing will receive a mark of zero on the assignment. Further repercussions range from suspension to expulsion depending on the number of previous infractions.

In recent years, artificial intelligence, machine learning and large language models have made it exceptionally easy to generate responses to specific homework questions and longer assignments. While Villanova College understands the importance of tools such as Chat GPT and Cactus AI in the educational space, it must be stated that presenting machine-generated samples as one's own work is a form of academic dishonesty. In general, a student's work is intended to be self-produced and original. If a student submits a significant piece of work for assessment that is found to be machine-generated, it must be reported to the Department Chair and Assistant Head - Curriculum. The teacher will assign a grade of zero to the academic work or that part of the academic work in question. Further repercussions include a meeting with senior administration that could lead to a suspension depending on the number of previous infractions of the Academic Integrity Policy.

Missed Work

Teachers will allow students adequate time to make up work because of a documented medical illness and for work missed while out on a school-sponsored event (excursion, retreat, co-curricular, etc.). Submission dates for previously scheduled projects/assignments must not be ignored due to school-sponsored events.

Late Assessments

Students who fail to submit assignments on the assigned due date will suffer the appropriate late penalty. All reasonable effort should be made to ensure that assignments are submitted on the due date. If an assignment can be submitted electronically, it should be submitted by the due date, even if the student is absent from school. If students are in attendance for part of a school day, they must submit all projects and assignments due that day. Signing in late to school or signing out early does not exempt a student from submission deadlines. Students who sign in late or sign out early for

scheduled appointments must advise the subject teacher if they will miss an assessment or evaluation. Failure to follow the above procedures will result in late penalties. (Student-Parent Handbook)

If the assignment is late/incomplete on initial due date, the student will receive a 5% penalty on the overall assignment.

If the assignment is late/incomplete on the 2nd due date, the student will receive a 10% penalty on the overall assignment.

If the assignment is late/incomplete on the 3rd due date, the student will receive a 20% penalty on the overall assignment.

If the assignment is late/incomplete on the final due date, the student is referred to the school's administration team.

Parents and students are encouraged to refer to the Villanova College Student-Parent handbook for a thorough explanation of our school's policy regarding academic integrity, missed work, late assignments and missed evaluations.

Test Centre

Students who are absent from school on the day of a test will be scheduled to write the missed test after school in the Test Centre on the day of their return (this includes mid-day sign in). Completion of tests takes priority over most school-related activities. For example, a student who has a VC game or performance or a previously scheduled appointment that has been communicated in advance may defer the test to the next school day, but a student with a practice or rehearsal is to write that day. Students who do not complete their tests within these parameters will be assigned a mark of zero. The Test Centre will operate Monday to Friday 3:00p.m. – 4:00p.m. Students are to arrive no later than 2:50 p.m. Extra time will not be provided for latecomers. Students must come prepared with all the materials they have been instructed to bring (i.e. calculator, ruler, etc.). Students must be in compliance with the school's uniform expectations, including dress shoes and blazer. If the student is not appropriately dressed, he/she will not be allowed to write their test until they are ready. Extra time will not be given for a student who needs to change. Coats and school bags may not be brought into the Test Centre room. Students are to abide by the academic integrity policy as outlined in the Student-Parent Handbook.

The following are not permitted in Test Centre:

- Cell phones
- Smartwatches
- Headphones

ESL students may not use their phones as dictionaries. A dictionary will be provided. Students who arrive late to the Test Centre will not be given extra time.

SAFE SCHOOL POLICY

All students, parents and teachers and other school staff have the right to be safe, and to feel safe, in their school community. With this right comes the responsibility to contribute to a positive school climate.

The Safe School Policy provides that all members of the school community must not:

- engage in bullying behaviours;
- commit sexual assault;
- traffic in weapons or illegal drugs;
- give alcohol to a minor;
- commit robbery;
- be in possession of any weapon, including firearms;
- use any object to threaten or intimidate another person;
- cause injury to any person with an object;
- be in possession of, or be under the influence of, or provide others with cigarettes, e-cigarettes, vaporizers, alcohol or illegal drugs;
- inflict or encourage others to inflict bodily harm on another person;
- engage in hate propaganda and other forms of behaviour motivated by hate or bias;
- commit an act of vandalism that causes extensive damage to school property or to property located on the premises of the school.

Where a student contravenes the Safe School Policy, the range of sanctions include removal from a school activity, detention, probation, in-school suspension, behaviour or performance contract, suspension or expulsion from school.

These standards of behaviour apply to students whether they are on school property, on school buses, at school-related events or activities, or in other circumstances that could have a negative impact on the school climate. The school reserves the right to suspend any student for any behaviour that the School believes negatively impacts the reputation of the School. This includes illegal drug and/or alcohol use and/or any activity that does not represent the moral tone and good name of the school or its community.

Bullying

Bullying is a serious issue that has far-reaching consequences for individuals, their families and peers and the community at large. It is recognized that:

- bullying adversely affects a student's ability to learn.
- bullying adversely affects the school climate, including healthy relationships.
- bullying will not be accepted on school property, at school-related activities, on school buses, or in any other circumstances (e.g. online) where engaging in bullying will have a negative impact on the school climate.

For the purposes of the Safe School Policy, bullying is defined as, "aggressive and typically repeated behaviour by a pupil whereby:

- a. the behaviour is intended by the pupil to have the effect of, or the pupil ought to know that the behaviour would be likely to have the effect of,
 - i. causing harm, fear, or distress to another individual, including physical, psychological, social or academic harm, harm to the individual's reputation or harm to the individual's property, or
 - ii. creating a negative environment at a school for another individual, and
- b. the behaviour occurs in a context where there is a real or perceived power imbalance between the pupil

and the individual based on factors such as size, strength, age, intelligence, peer group power, economic status, social status, religion, ethnic origin, sexual orientation, family circumstances, gender, gender identity, gender expression, race, disability or the receipt of special education.”

Cyberbullying is defined as bullying by electronic means, including:

- a. creating a web page or a blog in which the creator assumes the identity of another person;
- b. impersonating another person as the author of content or messages posted on the internet; and
- c. communicating material electronically to more than one individual or posting material on a website that may be accessed by one or more individuals.

Other examples of electronic or cyberbullying include:

- sending mean texts or instant messages to someone;
- hacking into someone’s social networking or gaming profile;
- being rude or mean to someone, harassing or threatening someone, sending mean messages, or spreading secrets, gossip, or rumours about people online (including through instant messages, texts, emails, and social media);
- pretending to be someone else to spread hurtful messages online;
- creating fake social media accounts, or creating blogs or websites, that ridicule someone;
- taking someone’s password and impersonating them online, or breaking into an email account and sending hurtful materials to others under an assumed identity;
- posting private or embarrassing photos online or sending them to others;
- engaging someone in instant messaging and tricking them into revealing personal information or images, and then forwarding it to others;

Roughhousing, fighting, pushing, shoving and disrespectful, violent or harassing behaviours are not acceptable. The school administration will not tolerate any form of aggressive and repeated behaviour that constitutes bullying. Bullying can take many forms which are often interrelated and include, but are not limited to:

Verbal	Name calling, put downs, threats, mocking, hurtful teasing, humiliating, or threatening someone, making people do things they don’t want to.
Physical	Hitting, punching, kicking, scratching, tripping, spitting.
Social	Ignoring, excluding, ostracizing, alienating, gossiping, spreading rumours, setting others up to look foolish, making sure others don’t associate with a person.
Psychological	Gossip, rumours, dirty looks, hiding/damaging possessions.
Sexual	Unwelcome sexual advances; requests for sexual favours, and other verbal, physical or graphic conduct of a sexual nature: direct, implied, spoken, or written (email, social media, etc.); unwanted and unwelcome behaviour about sex or gender that interferes with someone’s life and makes them feel uncomfortable; touching, pinching or grabbing someone in a sexual way; making crude comments about someone’s sexual behaviour, spreading a sexual rumour, using homophobic slurs.
Disability	Mocking, leaving someone out or treating someone badly because of a disability (e.g., learning, physical, speech); making someone feel uncomfortable because of a disability; making comments or jokes to hurt someone with a disability; using slurs related to disability.

Racial or Religious	Treating someone badly because of their racial, ethnic or religious background; saying negative things about a cultural or religious background; calling someone racist names; telling racist or inappropriate religious jokes.
Electronic	Using a computer or phone text messages or pictures to threaten or hurt someone's feelings; single out, embarrass or make someone look bad; spread rumours or reveal secrets about someone.

Providing students with an opportunity to learn and develop in a safe, inclusive and accepting school climate is a shared responsibility in which the school plays an important role. The school climate may be defined as the learning environment and relationships within the Villanova school community. Villanova promotes the creation of a safe, positive and supportive environment in which each student can enjoy his/her opportunities, both academic and social, and achieve his/her greatest potential educationally. Villanova College aims to foster high standards of behaviour based on cooperation, mutual responsibility, self-discipline and the promotion of positive and respectful relationships among students.

Hazing

Hazing is a type of bullying that involves humiliating and sometimes dangerous initiation rituals. Hazing is most often done by a group as a rite of admission into a group, club, or team; however, it can also be done by individuals. Hazing can be extreme, but it can also be more subtle. All forms of hazing are unacceptable at Villanova College.

Examples of hazing include:

Subtle hazing:

- excluding or ignoring someone;
- calling someone demeaning names;
- requiring someone to carry certain things around with them at all times, memorize certain things, or do things exclusively for one's entertainment;
- withholding certain information from someone, or deception as to that information;
- engaging in contests (athletic or otherwise) between groups of students (e.g. new students or team members vs. existing students or team members), which are purposefully unfair and do not promote friendly competition;

Harassment hazing:

- preventing someone from attending class, or engaging them with lengthy work sessions that do not allow adequate time for academic work and studies;
- requiring someone to perform ridiculous work assignments or personal service acts
- subjecting someone to deliberately uncomfortable conditions (such as wearing unusual, embarrassing, or uncomfortable clothing or costumes; requiring roundabout entrance to buildings; imposing silence periods; preventing or impeding personal hygiene practices);
- conducting any type of activity to falsely create respect and trust through trickery;
- verbal abuse (yelling, taunting, getting "in their face," etc.);
- nudity at any time, causing indecent exposure or embarrassment;

Violent hazing:

- forced consumption or ingestion of any substance (including alcohol, food, or other substances), or preventing eating, drinking water, or sleeping;
- sexual violation or unwarranted touching of the body;
- physical assault, including pushing, shoving, tackling, paddling, beating, striking, hitting, burning, branding, tattooing, and marking;
- throwing anything at or onto someone;
- physical or mental shocks, regardless of degree or nature, and any form of forced physical activities and exercise, whether extreme or not;
- forcing someone to participate in any activity or become involved in any situation that is in violation of law; contrary to the person's genuine moral or religious beliefs; or contrary to School rules.

Smoking and Vaping

Smoking and vaping are not permitted anywhere on the campus including the Marylake property itself. This policy extends to school functions, on or off school property. Students who are found to be in possession of or using tobacco products will be subjected to the strictest disciplinary actions warranted by the situation. As per the Smoke-Free Ontario Act, "You cannot smoke or vape in any public or private school's:

- indoor space
- outdoor grounds, including playgrounds and sports fields
- public areas within 20 metres of the school's grounds".

Drugs and Alcohol

Students of Villanova will not use, possess, procure or provide drugs, alcohol or paraphernalia or facilitate in any way the use, possession, procurement or provision of drugs, alcohol or paraphernalia. If the school has reasonable grounds to believe that any student has committed a criminal or quasi-criminal offence in relation to drugs or alcohol, it will so advise the police and will co-operate fully with any resulting investigation.

Cannabis is a substance which can cause impairment. Impairment at school creates health and safety risks for the school community and impedes the ability to learn. The School does not tolerate impairment at school. For students under age 19, cannabis remains an "illegal drug" within the meaning set out in this Handbook. Attending school under the influence of cannabis remains unlawful and is a violation of the Code of Conduct.

While there may be certain limited circumstances where cannabis use is lawful for adults in Ontario over age 19, the School strictly prohibits students over age 19 and adults from being impaired on school premises and such action will be considered a violation of the Code of Conduct.

A student who breaches this rule is subject to disciplinary action, including possible suspension or expulsion, at the school's discretion. In every case the penalty imposed will be adjusted to fit all relevant circumstances including the nature of the breach, the student's willingness to co-operate with rehabilitative and preventive measures and the student's general pattern of conduct including prior breaches of Code of Conduct.

School administration reserves the right to search a student, his/her locker or bag, where it has reasonable grounds to believe that a school rule has been breached and that a search of the student would reveal evidence of that breach.

DIPLOMAS AND CERTIFICATES

The Ontario Ministry of Education bestows upon Ministry-inspected schools to grant diplomas and certificates of achievement upon the completion of compulsory and optional credits.

The Value of an Ontario Secondary School Diploma

The Ontario Secondary School Diploma offers students the opportunity to pursue further educational aspirations at the post-secondary level and is welcomed by employers and trades programs. Statistically, more students attend post-secondary institutions in Ontario than any other province in Canada. By significantly increasing the employability of young men and women, the OSSD mitigates unemployment, poverty, and as a social determinant, increases the probability of overall health and well-being (Wellesley Institute).

Taking into consideration the advantages and benefits of the OSSD, The Government of Ontario mandates all students to remain in secondary school until they have reached the age of 18 or have obtained an Ontario Secondary School Diploma (OSSD). Villanova College is committed to reaching every student to help him or her achieve a successful outcome from the secondary school experience.

Definition of a Credit

A credit is granted when a course of at least 110 hours is completed successfully. A partial credit may be granted for a shorter course. For example, Grade 10 Career Studies and Civics are each worth 0.5 credits and each 55 hours in length.

Compulsory Credit Policy

All compulsory credits will be taken at Villanova College to guarantee the integrity and quality of the learning experience and the credit.

Ontario Secondary School Diploma (OSSD)

There are currently two versions of the OSSD, one for those students that started Grade 9 in 2023 or prior, and one for those students who started Grade 9 in 2024 or after. The OSSD requirements for both versions of the OSSD are listed below.

Students who started Grade 9 in 2023 or prior

In order to receive the Ontario Secondary School Diploma (OSSD), students are required to successfully complete a minimum of 30 credits, pass the Ontario Secondary School Literacy Test (OSSLT), and complete 40 hours of community involvement.

Compulsory Credits (Total 18)

- 4 credits in English (1 credit per grade)*
- 3 credits in Mathematics
- 2 credits in Science
- 1 credit in Canadian History
- 1 credit in Canadian Geography
- 1 credit in the Arts
- 1 credit in Health and Physical Education
- 1 credit in French as a Second Language
- 0.5 credit in Civics and 0.5 credit in Career Studies

Plus: 3 Group Credits

- **Group 1:** Additional credit in English, or French as a Second Language,** or a Native Language, or a Classical or an International Language, or Social Sciences and the Humanities, or Canadian and World studies, or Guidance and Career Education, or Cooperative Education***
- **Group 2:** Additional credit in Health and Physical Education, or the Arts, or Business Studies, or French as a Second Language,** or Cooperative Education***
- **Group 3:** Additional credit in Science (Grade 11 or 12), or Technological Education, or French as a Second Language,** or Computer Studies, or Cooperative Education***

*A maximum of 3 credits in English as a second language (ESL) or English literacy development (ELD) may be counted towards the 4 compulsory credits in English, but the fourth must be a credit earned for a Grade 12 compulsory English course.

**In groups 1, 2, and 3, a maximum of 2 credits in French as a Second Language can count as compulsory credits, one from group 1 and one from either group 2 or group 3.

***A maximum of 2 credits requirements in Cooperative Education can count as compulsory credits.

Optional Credits* (Total of 12)

In addition to the compulsory 18 credits, students must earn 12 optional credits in courses of their choice, selected from the list of courses available in the school.

*The 12 optional credits may include up to 4 credits earned through approved dual credit courses.

Additional Course Requirements

Each student must take a Religious Education and English course in each year he or she is attending Villanova College.

Students who started Grade 9 in 2024 or after

In order to receive the Ontario Secondary School Diploma (OSSD), students are required to successfully complete a minimum of 30 credits, pass the Ontario Secondary School Literacy Test (OSSLT), achieve a mark of 70% or higher in financial literacy, and complete 40 hours of community involvement.

Compulsory Credits (Total 17)

- 4 credits in English (1 credit per grade)*
- 3 credits in Mathematics
- 2 credits in Science
- 1 credit in Canadian History
- 1 credit in Canadian Geography
- 1 credit in the Arts
- 1 credit in Health and Physical Education
- 1 credit in French as a Second Language
- 1 credit in Technological Education (grade 9 or 10)
- 0.5 credit in Civics and 0.5 credit in Career Studies
- 1 credit from the STEM-related course group

STEM-related Course Group

Select 1 additional credit from the following group:

- Business studies
- Computer studies
- Cooperative education
- Mathematics (in addition to the 3 compulsory credits)
- Science (in addition to the 2 compulsory credits)
- Technological Education (in addition to the 1 compulsory credit)

*A maximum of 3 credits in English as a second language (ESL) or English literacy development (ELD) may be counted towards the 4 compulsory credits in English, but the fourth must be a credit earned for a Grade 12 compulsory English course.

Optional Credits* (Total of 13)

In addition to the compulsory 17 credits, students must earn 13 optional credits in courses of their choice, selected from the list of courses available in the school.

*The 13 optional credits may include up to 4 credits earned through approved dual credit courses.

Additional Course Requirements

Each student must take a Religious Education and English course in each year he or she is attending Villanova College.

Requirements for the Ontario Secondary School Certificate*

The Ontario Secondary School Certificate will be granted on request to students who leave school before earning the Ontario Secondary School Diploma (OSSD) provided they have earned a minimum of 14 credits distributed as follows:

Compulsory Credits (Total of 7)

- 2 credits in English
- 1 credit in Canadian Geography or Canadian History
- 1 credit in Mathematics
- 1 credit in Science
- 1 credit in Health and Physical Education
- 1 credit in the Arts, Technological Education or Computer Studies

Optional Credits (Total of 7)

- 7 credits selected by the student from available courses

* Villanova College will only issue Ontario Secondary School Certificates in a few exceptional situations.

The Certificate of Accomplishment*

Students who leave school before fulfilling the requirements for the Ontario Secondary School Diploma or the Ontario Secondary School Certificate may be granted a Certificate of Accomplishment. This certificate may be a useful means of recognizing achievement for students who plan to take certain vocational programs, other kinds of training or who plan to find employment after leaving school. Students who return to school to complete additional credit and non-credit courses will have their transcript updated accordingly but will not be issued a new Certificate of Accomplishment.

* Villanova College will only issue Certificates of Accomplishment in a few exceptional situations.

Villanova College Diploma

The Villanova College Diploma signifies the achievement of demonstrated evidence of a student to live the Christian ideals that have contributed to the life of the school in addition to the academic and behavioural requirements needed to remain in good standing. The Villanova College Diploma is awarded to students who apply directly to the President and, in addition to the OSSD requirements, have completed the following minimum requirements:

- a total of 30 credits (including all compulsory credits) attained or approved by Villanova College (for students enrolled from grade 9)

- a total of 7 Grade 12 credits attained through Villanova College
- a minimum average of 75% in Religion courses from Grades 9–12 or recommendation by the instructor in the Grade 12 Seminar course
- a minimum overall average of 75% in the student’s graduating year
- conduct free of any major disciplinary, deportment, attendance, patterns of tardiness and academic dishonesty issues
- attendance at all weekly prayer and liturgical services and advisor sessions
- a minimum of fifty (50) hours of voluntary service to the school prior to graduation
- participation in all school retreats
- participation in one or more of the following programs in each year of his/her enrollment:

Athletics	Arts	Student Government	Clubs
Peer Tutoring / Mentoring	Outreach	Campus Ministry	Service to School

COMPULSORY NON-CREDIT REQUIREMENTS OF THE OSSD

The Ontario Secondary School Literacy Test (OSSLT)

Students must successfully complete the provincial Grade 10 Ontario Secondary School Literacy Test (OSSLT) to earn a secondary school diploma. Villanova College will not defer or exempt students from participating in the OSSLT. The test will be administered in Grade 10 and is based on the Ontario curriculum expectations for reading and writing that have been identified across the curriculum up to and including Grade 9. Accommodations will be provided for all students with an I.E.P. and those enrolled in ESL classes.

The results of the OSSLT will be reported as complete or incomplete. Students who receive an incomplete will be given clear feedback regarding their performance to help them address the areas where improvement is required. Students who are not successful will be required to retake the test. If a student is still unsuccessful on their second attempt, they will take the Ontario Secondary School Literacy Course (OLC40) and successful completion of the course will satisfy the literacy requirement for the OSSD. The OLC40 course is not offered at Villanova College; however, Student Services will be able to direct students to available programs within the community.

Financial Literacy

Starting in September 2026, students must earn a new financial literacy graduation requirement as part of their compulsory Grade 10 mathematics course. They will need to achieve a mark of 70% or higher to pass this new requirement and earn their high school diploma.

Community Involvement

As part of the diploma requirements, students must complete a minimum of 40 hours of community involvement activities prior to graduation. This initiative is intended to encourage students to develop an understanding of civic responsibility and the role they can play in supporting and strengthening their communities. The requirement is to be completed outside of the student’s normal instructional hours. The activities are to take place in the student’s designated lunch hours, after school, on weekends, or during school holidays. Each student must maintain a record of

his or her community involvement activities. Villanova will distribute a community involvement information guide to each student. Students are permitted to begin accumulating community service hours the summer following the completion of their Grade 8 year. Listed below are the eligible and ineligible activities.

Eligible Activities for Community Involvement

- **Elementary Schools** – assist with school events, assist School Councils, activities for children
- **Secondary Schools** – organization and leadership of school activities that benefit the community
- **Animal Care** – volunteering in a zoo, animal shelter, or on a farm
- **Arts and Culture** – volunteering in galleries, libraries, community productions
- **Charitable Organizations** – assisting with special events, programs, clerical tasks
- **Children/Youth Programs** – assisting with children/youth programs, volunteering in a not-for-profit childcare centre or camp
- **Community Organizations** – assisting with special events, food banks, community support services, shelters, clerical tasks
- **Community Service for Individuals** – assisting community members in need
- **Environmental Projects** – flower/tree planting, beautification projects, recycling projects, recycling depot
- **Health Agencies** – volunteering in hospitals, hospices, Canadian Blood Services (volunteering to organize or assist with a blood donor clinic), donating blood (time required to donate)
- **Law Enforcement Agencies** – volunteering for activities sponsored by the police
- **Political Organizations** – activities related to legitimate and recognized political organizations: municipal, provincial, and federal political activities except for those supporting public school board trustees
- **Religious Organizations** – assisting with programs, special events
- **Senior Citizens** – assisting in seniors' residences, providing services for seniors in the community
- **Sports and Recreation** – coaching, organizing special events, assisting with projects/events; or
- **Service-Focused Club Activities** – activities that expand community service to others beyond the school day (holiday dinner participation, environmental action activities, etc.)

Ineligible Activities for Community Involvement

- involves any work for a for-profit organization
- is a requirement of a class or course in which the student is enrolled
- takes place during the time allotted for the instructional program on a school day, with the exception of an activity that takes place during the student's lunch breaks or "spare" periods, which is permissible
- takes place in a logging or mining environment, if the student is under 16 years of age
- takes place in a factory if the student is under 15 years of age
- takes place in a workplace other than a factory, if the student is under 14 years of age and is not accompanied by an adult
- would normally be performed for wages by a person in the workplace
- involves the operation of a vehicle, power tools, or scaffolding
- involves the administration of any type or form of medication or medical procedure to other persons
- involves handling of substances classed as "designated substances" under the Occupational Health and Safety Act
- requires the knowledge of a tradesperson whose trade is regulated by the provincial government
- involves banking or the handling of securities, or the handling of jewellery, works of art, antiques, or other valuables

- consists of duties normally performed in the home or personal recreational activities
- involves a court-ordered program
- involves any volunteer work for a public-school board trustee; or
- involves participation in extra-curricular activities at secondary school, or any position for which a student stands for school-wide election

Christian Service at Villanova College

The Ontario Ministry of Education requires that 40 hours of community service be completed by the end of Grade 12. At Villanova College, we deepen this requirement both spiritually and in terms of the time commitment.

Inspired by the example of Jesus Christ, our Augustinian patron, St. Thomas of Villanova, and the teachings of the Catholic Church, we require every student to engage in Christian Service experiences in each of their high school years, to a minimum total of 60 hours by the end of Grade 12. Christian Service is different from community service because of its intent and its personal focus. Christian Service is an attempt to share one's time, gifts and talents with someone, or a non-profit organization, in real need out of love of God and neighbour. It is the living out of our Christian faith through the fulfillment of the corporal works of mercy that are directed to the physical well-being of others and the spiritual works of mercy that are directed to the spiritual well-being of others.

ALTERNATIVE WAYS OF EARNING CREDITS

Villanova College may offer alternative ways for students to obtain credits toward their OSSD, other than courses offered at the school. These options may include correspondence courses offered by the Independent Learning Centre, independent study, private study, programs in music taken outside of the school, and Villanova summer school courses. Enrollment in any of these alternative ways of earning a credit must be made in consultation with the student, parents, Student Services, and the Head of Upper School. Although there are many opportunities for students to participate in field trips and other experiential learning, Villanova College does not offer a co-operative education program.

E-Learning

In Ontario, students, beginning with those who entered Grade 9 in the 2020-21 school year, are required to earn two online learning credits in order to earn their Ontario Secondary School Diploma. This graduation requirement is intended to support students in developing familiarity and comfort with working and learning in a fully online environment, as well as developing digital literacy and other important transferable skills that will help prepare them for success after graduation and in all aspects of their lives.

Rationale for exemption:

At Villanova College, we believe that the interpersonal, relational model of education is foundational for student success and deep learning. Our daily routine consists of incorporating various technological resources, digital literacy and frequent asynchronous and synchronous learning. By graduation, we are confident that all of our students are fully prepared for learning in a virtual environment. Because of this, Villanova College opts out of the requirement of two e-learning credits.

Request for Opt-in:

Villanova may allow for students and parents or guardians to opt back into the e-learning graduation requirement should they decide. Students and parents who wish to voluntarily take online courses may do so with permission of The Director of Student Services. Villanova College will accept certain online credits towards graduation. Students are not permitted to take English or Religion via e-learning. Students who successfully complete 2 e-learning credits will have the credits specified as e-learning on their Ontario Student Transcript.

Prior Learning Assessment and Recognition (PLAR)

There are two components to prior learning assessment and recognition: “equivalency” and “challenges.”

Equivalencies

Equivalencies are credits granted to incoming students from an educational jurisdiction outside Ontario. Ontario credit equivalencies are granted for work done prior to enrollment at Villanova. The Ontario Ministry of Education allows students to be granted standing in an Ontario school at the same level and grade as their sending jurisdiction. Based on this standard, the number of credits still to be earned toward an Ontario Secondary School Diploma and other criteria to be met, including service hours and completion of the Ontario Secondary School Literacy Test, are assessed. In most cases a student entering Villanova from outside Ontario would transfer in at a Grade equivalent to their standing in their current school system.

Challenge

Villanova College does not participate in the course challenge process.

Music Certificates Accepted for Credit

The Ontario Ministry of Education provides an opportunity for students to obtain up to two music credits towards the Ontario Secondary School Diploma (OSSD) with the completion of approved music certificates. Further, according to the Education Act, a student may be “absent from school for the purpose of receiving instruction in music and the period of absence does not exceed one-half day in any week”. Students must abide by the following criteria:

1. A maximum of one Grade 11 university/college preparation music credit may be awarded towards the OSSD for the successful completion of one of the following:
 - a. Grade VII Practical and Intermediate Rudiments (formerly Grade 1 Rudiments) of the Royal Conservatory of Music, Toronto
 - b. Grade VII Practical and Grade III Theory of Conservatory Canada, London, Ontario
 - c. Collegial I Practical and Collegial I Theory of any conservatory of music in the province of Quebec
 - d. Grade V Practical and Grade III Theory of Trinity College London, England
 - e. Grade VII Practical and Grade VI Theory of the Royal Schools of Music, London, England

2. A maximum of one Grade 12 university/college preparation music credit may be awarded towards the OSSD for the successful completion of one of the following:
 - a. Grade VIII Practical and Advanced Rudiments (formerly Grade II Rudiments) of the Royal Conservatory of Music, Toronto
 - b. Grade VIII Practical and Grade IV Theory of Conservatory Canada, London, Ontario
 - c. Collegial II Practical and Collegial II Theory of any conservatory of music in the province of Quebec
 - d. Grade VI Practical and Grade IV Theory of Trinity College London, England
 - e. Grade VIII Practical and Grade VIII Theory of the Royal Schools of Music, London, England

Notes:

1. The term practical refers to any musical instrument on which performance is examined. It includes voice (i.e., singing), but not speech arts.
2. The mark credited to the student is calculated by averaging the marks that the student has earned in the practical component and in rudiments or theory.

Reach Ahead Credits

Under exceptional circumstances, Villanova College has an established procedure for the supervision of individual elementary school students who reach ahead to take secondary school courses. Villanova College maintains appropriate records for these students.

VC Procedures:

- Parental consent form must be signed and included in the student's OSR.
- The school maintains evidence and documentation of the assessments and evaluations that support the achievement of the overall expectations of the course.
- The Head of Upper School has final approval in the granting and recording of the credit.
- The successful completion of the course is noted on the OST once the student enters Grade 9.

Students who transfer to a new school in Grade 9 will have a letter of achievement included in their OSR.

STUDENT ACHIEVEMENT

Assessment and evaluation are based on the curriculum expectations and the achievement levels outlined in the curriculum policy document for each discipline. Methods of evaluation and assessment vary according to subject area and may include oral presentations, assignments, projects, unit tests, independent study units, rubrics, and formal examinations. A final grade is recorded for each course and a credit is granted for every course in which the student's grade is 50% or higher. Each student will receive a course syllabus that breaks down the content of each course and the allocation of marks.

All aspects of Villanova College's Assessment, Evaluation, and Reporting policies are in compliance with the Ontario Ministry of Education document, GROWING SUCCESS, Assessment, Evaluation, and Reporting in Ontario Schools, Grades

1 -12, 2010. Teachers will use multiple forms of assessment to both determine a student's achievement of the curriculum expectations in a subject or course, as well as to determine how to best support students' further learning in the course. To that end, teachers will use three types of assessment, as described in the Growing Success document:

Assessment of Learning occurs at or near the end of a cycle of learning and summarizes a student's learning at a given point in time in relation to established criteria.

Assessment as Learning occurs during the learning cycle and provides students with feedback (teacher, self and peer) to help them develop a metacognitive understanding of their own learning and determine next steps.

Assessment for Learning occurs throughout the learning cycle and allows teachers and students to determine where students are in their learning and what improvements can be made in order for the student to achieve success.

Villanova College cannot stress enough the necessity of regular attendance and consistent daily work to maintain acceptable levels of achievement. Villanova College will not grant credits to students in courses where attendance has been deemed unacceptable. While Villanova College will attempt to assist each student in every way possible to meet his or her educational objectives, a graduation diploma does not guarantee admission to post-secondary institutes. Certain subject prerequisites are necessary for entrance to courses and educational institutions. Villanova encourages all students, regardless of their grade level, to assume a long-range interest in their course selections and achievement. It is ultimately each student's responsibility to earn those credits and marks which will meet all requirements for their diplomas and post-secondary goals.

There will be three formal reporting periods throughout the school year - November, February, and June. Parents and students will also be updated on a regular basis through the subject teachers.

Final examinations for some courses are held in June. Final exams are formal and are held in separate locations such as the GAC and the GLC. A two-day review period ensues prior to exams and these assessments usually carry a weight of 10 percent up to a maximum of 30 percent.

Parents and students are encouraged to refer to the Villanova College Student-Parent handbook for a thorough explanation of our school's assessment, evaluation and examination policies.

COURSE SELECTION

The Organization of Secondary School Courses

The secondary school program is designed to provide all students with the essential knowledge and skills that they will need for the future, as well as the opportunity to specialize in areas that are related to post-secondary school goals.

Academic Rigour

As a university preparatory school, Villanova College focuses on providing exceptional academic rigour via its academic, university preparation, and university/college preparation courses. Open courses compliment the school curriculum and provide students with compulsory and optional credits. With this in mind, applied, college, and workplace courses do not fall within the scope or vision of our school.

Syllabus

A course syllabus/ course of study is based on the curriculum expectations set out by the Ministry of Education policy documents and Villanova College. They can be accessed by parents and students on Edsby under the library section in each course.

Access to Ontario Curriculum Documents

All Ontario Ministry of Education documents can be accessed online. For curriculum documents, click here: <http://www.edu.gov.on.ca/eng/teachers/curriculum.html>.

Explanation of Course Codes

Each secondary school course is identified by a five-character code:

- The first three characters refer to the subject: ENG is English.
- The fourth character refers to the grade or level: 1, 2, 3, 4 refers to Grades 9, 10, 11, 12.
- The fifth character refers to the type of course:

W	D	P	O	U	M	C	E
Destreamed	Academic	Applied	Open	University	Mixed U/C	College	Workplace

Course Code Examples:

- ENL1W = **ENL** (English) **1** (Grade 9) **W** (**De-streamed**)
- MPM2D = **MPM** (**M**ath – **P**inciples of **M**athematics) **2** (Grade 10) **D** (Academic)
- SPH3U = **SPH** (**S**cience - **P**hysics) **3** (Grade 11) **U** (University Preparation)
- MCV4U = **MCV** (**M**athematics – **C**alculus and **V**ectors) **4** (Grade 12) **U** (University Preparation)

Changing Course Types

Villanova College only offers Academic, Open, University, University/college courses. As such, students have no need to transition from one course type to another.

Grades 9 and 10

In Grades 9 and 10, course types which may be offered at Villanova College to prepare students for Grades 11 and 12 are: Academic and Open.

De-streamed (W)

De-streamed courses are built on the elementary programs and are based on the same fundamental principles. These courses are designed to be inclusive of all students to facilitate their transition from the elementary grades to the secondary level. They offer opportunities for all students to build a solid foundation in each subject area, broaden their knowledge and skills, and develop their identities as critical learners.

Academic Courses (D)

Academic courses focus on the essential concepts of the discipline and also explore related concepts. Academic courses develop students' knowledge and skills by emphasizing theoretical, abstract applications of the essential concepts and incorporating practical applications where applicable.

Open Courses (O)

Open courses have one set of expectations for the discipline, appropriate for all students in a given grade. These courses are designed to prepare students for further study in certain subjects and to enrich their education.

Grade 9 Course Selection

Students enrolled in the grade 9 program at Villanova College will take the following courses:

- English (ENL1W)
- Principles of Mathematics (MTH1W)
- Science (SNC1W)
- Core French (FSF1D)
- Religion (HRE13)
- Issues in Canadian Geography (CGC1W)
- Healthy Active Living Education (PPL1O)
- Instrumental Music (AMU1O/AMU2O*), Visual Arts (AVI1O), or Technology (TAS2O)

*AMU2O is only open to students who participated in the music program at Villanova College in grade 8.

Grade 10 Course Selection

Students enrolled in the grade 10 program at Villanova College will take the following courses:

- English (ENG2D)
- Principles of Mathematics (MPM2D)
- Science (SNC2D)
- Religion (HRE23)
- Canadian History Since WWI (CHC2D)
- Career Studies (GLC2O) (0.5 credit)
- Civics (CHV2O) (0.5 credit)
- An additional two elective courses

Grades 11 and 12

In Grades 11 and 12, courses offered at Villanova College will be: University Preparation courses (U coded), University/College Preparation courses (M coded), and Open courses. Please note: At Villanova College, University Preparation and/or University/College Preparation will be the only courses offered in the majority of subject areas.

University Preparation Courses (U)

University preparation courses are designed to equip students with the knowledge and skills they need to meet the entrance requirements for university programs. The range of courses offered, and the content of these courses will allow students to prepare for any university program and related career. Teaching and learning will emphasize theoretical aspects of the course content but will also include concrete applications. All university preparation courses will be based on rigorous provincial curriculum expectations and will emphasize the development of both independent research skills and independent learning skills. Students will be required to demonstrate that they have developed these skills.

University/College Preparation Courses (M)

University/College preparation courses include content that is relevant for both university and college programs. These courses are designed to equip students with the knowledge and skills they need to meet the entrance requirements for specific university and college programs. The range of courses offered, and the content of these courses will allow students to prepare for university and college programs and related careers. Teaching and learning will emphasize both theoretical aspects and related concrete applications of the course content. All university/college preparation courses will be based on rigorous provincial curriculum expectations and will emphasize the development of both independent research skills and independent learning skills. Students will be required to demonstrate that they have developed these skills.

Open Courses in Grades 11 and 12 (O)

Open courses in Grades 11 and 12 allow students to broaden their knowledge and skills in a particular subject that may or may not be directly related to their post-secondary goals, but that reflects their interests. These courses are appropriate for all students regardless of their post-secondary destination. These courses are designed to provide students with a broad educational base and to equip them for active and rewarding participation in society. They are not designed with specific requirements of university college programs or the workplace in mind.

Grade 11 Course Selection

Students in Grade 11 will focus more on their individual interests and identify and prepare for initial post-secondary goals. Villanova College will offer courses at the university, university/college and open levels only. The goal of Villanova College is to provide students with a breadth of courses in Grades 11 and 12 so that students may enter the post-secondary program of their choice. Students are advised to research Ontario university program specific admission requirements at www.ontariouniversitiesinfo.ca in order to ensure that they have the required prerequisites.

Students enrolled in Grade 11 will take the following compulsory courses:

- English (ENG3U)
- Functions (MCR3U) or Functions and Applications (MCF3M)
- World Religions: Beliefs, Issues and Religious Traditions (HRT3M)
- An additional five elective courses

Grade 12 Course Selection

All students registered at Villanova College must be full time students. By definition, in Grade 12 this means they are carrying a minimum course load of six credit courses (with no more than 2 study halls). However, Villanova College strongly advises our Grade 12s to choose a minimum of seven credit courses. University admission is based on the average of the best six 4U/4M level course marks including pre-requisites. If a student submits grades for more than six courses, the universities choose the marks from required courses and then the highest scores available. This allows the lowest mark(s) to be eliminated, if it is not a prerequisite, when the admission average is calculated. This is to the advantage of the student. Students are advised to research the program specific requirements for Ontario universities at www.ontariouniversitiesinfo.ca and consult with their guidance counsellor. Similarly, students may also refer to www.ontariocolleges.ca for program specific requirements to Ontario colleges.

Students enrolled in Grade 12 will take the following compulsory courses:

- English (ENG4U) or AP English Literature and Composition (ENG4UP)
- Church and Culture (HRE4M), Philosophy: Questions and Theories (HZT4U), or Leaders in Church and Culture (HRE4M1)* (*Application required.)
- A minimum of four elective courses

Villanova College Course Selection Planning Chart

Grade 9	Grade 10	Grade 11	Grade 12
ENL1W	ENG2D	ENG3U	ENG4U
MTH1W	MPM2D	HRT3M	HRE4M/HRE4M1/HZT4U
SNC1W	SNC2D	MCR3U or MCF3M	Elective
FSF1D	CHC2D	Elective	Elective
PPL1O	HRE23	Elective	Elective
CGC1W	CHV2O/GLC20	Elective	Elective
HRE13	Elective	Elective	Elective
Arts or Technology Elective	Elective	Elective	Elective

All returning Villanova College students will complete course selection online at <https://login.xello.world/>. Each Villanova College student has a unique username and password to access their account. To access an account for the first time, students would login using the following information:

Username: Prefix (VILLA-00000) + Student ID – e.g., VILLA-00000StudentID

Password: Student's Date of Birth (MMDDYYYY) – e.g., 09192006 (September 19, 2006)

Course selection forms will be considered complete only after course options have been submitted online through Xello and the Course Request sheet signed by a parent/guardian has been submitted to Student Services. The deadline to submit the Course Request sheet to Student Services is January 30th, 2026. **For a complete list of course descriptions, please see pages 51-79.**

ADVANCED PLACEMENT

What is the AP Program?

The Advanced Placement Program is a cooperative educational endeavour between secondary schools and universities. Since its inception in 1955, it has provided high school students with enriched university level courses in a high school setting. Students who participate in the AP program not only gain university level skills, but in some cases, may earn university credit while they are still in high school.

Villanova College continues to offer several Advanced Placement (AP) courses in conjunction with, and as an enhancement of, Ontario courses. High school teachers find that AP courses enhance their students' confidence and stimulate their academic interest. AP courses allow students to study at a higher level and intensity in subjects of their choosing in academic areas where they feel they have expertise and interest. Additional course hours are provided to cover part of the course.

Every AP course has a corresponding exam that is administered in May. AP exams represent the culmination of AP courses and are an integral part of the program. As a result, Villanova College requires all students enrolled in an AP course to take the AP exam. There is an exam fee that will be charged for each AP exam taken.

Qualifying AP Exam scores of 4 or 5 earn university credit in many universities in the United States and Canada, as well as internationally. While some AP courses may be used in admission decisions for international universities, AP grades are not considered as part of the application process for Canadian universities.

AP Selection Criteria

The following criteria will be used to select students who apply to the Pre-AP and AP programs:

- Students must meet all pre-requisites to be admitted into an AP course.
- Above grade level performance in the pre-requisite subject
- A desire and aptitude to be in an advanced and independent learning environment as demonstrated through the student's learning skills
- Recommendation of teacher, department chair, and input from Student Services
- Exemplary attendance record
- Students may be required to complete an additional assessment at the discretion of the school.

Additional student responsibilities:

- Pay the additional course fee for each AP course. This fee will be applied directly to the AP examination.
- The expectation for enrollment is that the level and quality of student work replicate that of work required in a university course. Students must be willing to undertake the rigorous demands of the AP class.
- Students are required to take the AP exam.
- The AP exam schedule is set by the College Board and cannot be altered. Students will NOT be exempt from the exam due to conflicts, either personal or academic.
- Students may be required to complete preparatory material in advance of the course start date.

The Exam

For each AP course, a standardized AP Exam is administered at participating schools worldwide. Each AP Exam contains a free-response section (either essay or problem-solving) and a section of multiple-choice questions.

Each AP Exam is graded according to the following chart:

Level	Qualification:	Notes:
5	Extremely well qualified	These exams are written in May. Students in the AP program will also be writing the final June exam in their subject for Villanova College. The granting of the university credit is up to the university.
4	Well qualified	
3	Qualified	
2	Possibly qualified	
1	No recommendation	The cost to participate in the AP program is \$150 CND per exam.
*A student does not have to be enrolled in an AP course in order to sit for an AP exam.		

AP courses offered at Villanova College are:

- Chemistry
- English Literature and Composition
- Calculus AB
- Statistics
- Physics 1
- Physics 2
- Biology
- Macroeconomics
- Microeconomics

AP Course Descriptions

CIA4U **Advanced Placement Macroeconomics / Advanced Placement Microeconomics**
Grade 12, University Preparation

This course examines current Canadian and international economic issues, developments, policies, and practices from diverse perspectives. Students will explore the decisions that individuals and institutions, including governments, make in response to economic issues such as globalization, trade agreements, economic inequalities, regulation, and public spending. Students will apply the concepts of economic thinking and the economic inquiry process, as well as economic models and theories, to investigate, and develop informed opinions about, economic trade-offs, growth, and sustainability and related economic issues. AP Macroeconomics/AP Microeconomics is an introductory university-level economics course. Students cultivate their understanding of the principles that apply to an economic system as a whole by using principles and models to describe economic situations and predict and explain outcomes

with graphs, charts, and data as they explore concepts like economic measurements, markets, macroeconomic models, and macroeconomic policies.

Students will also study the Ontario curriculum for CIA4U and will receive the CIA4U credit on their transcript. They will write the AP Microeconomics in May.

Prerequisite: The Individual and the Economy, Grade 11, University/College Preparation

Course Fee: \$250 CND (AP exam and textbook fee)

Selection Criteria: A minimum of 85% in MCR3U, recommendation of teacher and department chair.

ENG4U Advanced Placement English Literature and Composition Grade 12, University Preparation

This course emphasizes the consolidation of the literacy, communication, and critical and creative thinking skills necessary for success in academic and daily life. Students will analyze a range of challenging literary texts from various periods, countries, and cultures; interpret and evaluate informational and graphic texts; and create oral, written, and media texts in a variety of forms. An important focus will be on using academic language coherently and confidently, selecting the reading strategies best suited to particular texts and particular purposes for reading, and developing greater control in writing. The course is intended to prepare students for university, college, or the workplace. An AP course in English Literature and Composition engages students in the careful reading and critical analysis of imaginative literature. Through the close reading of selected texts, students deepen their understanding of the ways in which writers use language to provide both meaning and pleasure for their readers. As they read, students consider a work's structure, style, and themes as well as such smaller-scale elements as the use of figurative language, imagery, symbolism and tone.

Students will also study the Ontario curriculum for ENG4U and will receive the ENG4U credit on their transcript. They will write the AP English Literature and Composition exam in May.

Prerequisite: English, Grade 11, University Preparation

Course Fee: \$150 CND
(AP exam fee)

Selection Criteria: A minimum of 85% in ENG3U, recommendation of teacher and department chair.

MCV4U Advanced Placement Calculus AB Grade 12, University Preparation

This course builds on students' experience with functions and their developing understanding of rates of change. Students will solve problems involving geometric and algebraic representations of vectors, and representations of lines and planes in three-dimensional space; broaden their understanding of rates of change to include the derivatives of polynomial, sinusoidal, exponential, rational and radical functions; and apply these concepts and skills to the modeling of real-world relationships. Students will also refine their use of the mathematical processes necessary for success in senior mathematics. This course is intended for students who choose to pursue careers in fields such as science, engineering, economics, and some areas of business including those students who will be required to take a university-level calculus, linear algebra, or physics course. This course is primarily concerned with developing student understanding of the concepts of calculus and providing experience with its methods and applications. The course emphasizes a multi-representational approach to calculus, with concepts, results, and problems being expressed

graphically, numerically, analytically, and verbally. Students will solve problems involving geometric and algebraic representations of vectors, and representations of lines and planes in three-dimensional space; broaden their understanding of rates of change to include the derivatives of polynomial, sinusoidal, exponential, rational and radical functions; and apply these concepts and skills to the modeling of real-world relationships. Students will also refine their use of the mathematical processes necessary for success in senior mathematics. This course is intended for students who choose to pursue careers in fields such as science, engineering, economics, and some areas of business including those students who will be required to take a university-level calculus, linear algebra, or physics course.

Students will also study the Ontario curriculum for MCV4U and will receive the MCV4U credit on their transcript. They will write the AP Calculus AB exam in May.

Prerequisite: Advanced Functions, Grade 12, University Preparation

Course Fee: \$150 CND

Selection Criteria: A minimum of 90% in MHF4U or successful completion of MHF4UST, recommendation of teacher and department chair.

(AP exam fee)

MDM4U **Advanced Placement Statistics**
Grade 12, University Preparation

This course broadens students' understanding of mathematics as it relates to managing data. Students will apply methods for organizing large amounts of information; solve problems involving probability and statistics; and carry out a culminating investigation that integrates statistical concepts and skills. Students will also refine their use of the mathematical processes necessary for success in senior mathematics. Students planning to enter university programs in business, the social sciences, and the humanities will find this course of particular interest. This course broadens students' understanding of mathematics as it relates to managing data. Students are introduced to the major concepts and tools for collecting, analyzing, and drawing conclusions from data. There are four themes in the course: exploring data, sampling and experimentation, anticipating patterns, and statistical inference. Students use technology, investigations, problem solving, and writing as they build conceptual understanding. Students will apply methods for organizing large amounts of information; solve problems involving probability and statistics; and carry out a culminating investigation that integrates statistical concepts and skills.

Students will also study the Ontario curriculum for MDM4U and will receive the MDM4U credit on their transcript. They will write the AP Statistics exam in May.

Prerequisite: Functions, Grade 11, University Preparation

Course Fee: \$150 CND

Selection Criteria: A minimum of 90% in MCR3U or successful completion of MCR3UST, recommendation of teacher and department chair.

(AP exam fee)

SBI4U **Advanced Placement Biology**
Grade 12, University Preparation

This course provides students with the opportunity for in-depth study of the concepts and processes associated with biological systems. Students will study theory and conduct investigations in the areas of metabolic processes, molecular genetics, homeostasis, evolution, and population dynamics. Emphasis will be placed on achievement of the detailed knowledge and refined skills needed for further study in various branches of the life sciences and related fields. AP Biology is an introductory university-level biology course. Students cultivate their understanding of biology

as they explore the following topics: evolution, cellular processes — energy and communication, genetics, information transfer, ecology, and interactions. Students will engage in hands-on, inquiry-based investigations that will require students to ask questions, make observations and predictions, design experiments, analyze data, and construct arguments in a collaborative setting, where they direct and monitor their progress.

Students will also study the Ontario curriculum for SBI4U and will receive the SBI4U credit on their transcript. They will write the AP Biology exam in May. Preparation: Students will be required to complete a summer self-study component to prepare for the course.

Prerequisite: Biology, Grade 11, University Preparation

Selection Criteria: A minimum of 90% in SBI3U, recommendation of teacher and department chair.

Course Fee: \$400 CND
(AP exam and textbook fee)

SCH3U Pre-Advanced Placement Chemistry Grade 11, University Preparation

This course enables students to deepen their understanding of chemistry through the study of the properties of chemicals and chemical bonds; chemical reactions and quantitative relationships in those reactions; solutions and solubility; and atmospheric chemistry and the behaviour of gases. Students will further develop their analytical skills and investigate the qualitative and quantitative properties of matter, as well as the impact of some common chemical reactions on society and the environment.

Students will also study the Ontario curriculum for SCH3U and will receive the SCH3U credit on their transcript.

Prerequisite: Science, Grade 10, Academic

Selection Criteria: A minimum of 90% in SNC2D or successful completion of SNC2DST, recommendation of teacher and department chair.

SCH4U Advanced Placement Chemistry Grade 12, University Preparation

This course enables students to deepen their understanding of chemistry through the study of organic chemistry, energy changes and rates of reaction, chemical systems and equilibrium, electrochemistry, and atomic and molecular structure. Students will further develop problem-solving and laboratory skills as they investigate chemical processes, at the same time refining their ability to communicate scientific information. Emphasis will be placed on the importance of chemistry in daily life, and on evaluating the impact of chemical technology on the environment. The AP Chemistry course provides students with a foundation to support future advanced course work in chemistry. Through inquiry-based learning, students develop critical thinking and reasoning skills. Students cultivate their understanding of chemistry and science practices as they explore topics such as: atomic structure, intermolecular forces and bonding, chemical reactions, kinetics, thermodynamics, and equilibrium.

Students will also study the Ontario curriculum for SCH4U and will receive the SCH4U credit on their transcript. They will write the AP Chemistry exam in May.

Prerequisite: Advanced Placement Chemistry 1, Grade 11, University Preparation
Selection Criteria: A minimum of 90% in SCH3U or successful completion of SCH3UST,
recommendation of teacher and department chair.

Course Fee: \$400 (AP
exam and textbook fee)

SPH3U **Advanced Placement Physics 1**
Grade 11, University Preparation

This course develops students' understanding of the basic concepts of physics. Students will explore kinematics, with an emphasis on linear motion; different kinds of forces; energy transformations; the properties of mechanical waves and sound; and electricity and magnetism. They will enhance their scientific investigation skills as they test laws of physics. In addition, they will analyze the interrelationships between physics and technology, and consider the impact of technological applications of physics on society and the environment. AP Physics 1 is an algebra-based, introductory university-level physics course that explores topics such as Newtonian mechanics (including rotational motion); work, energy, and power; mechanical waves and sound; and introductory, simple circuits. Through inquiry-based learning, students will develop scientific critical thinking and reasoning skills.

Students will also study the Ontario curriculum for SPH3U and will receive the SPH3U credit on their transcript. They will write the AP Physics 1 exam in May.

Prerequisite: Science, Grade 10, Academic,
Selection Criteria: Minimum 90% in SNC2D or successful completion of SNC2DST,
recommendation of teacher and department chair.

Course Fee: \$400 (AP
exam and textbook fee)

SPH4U **Advanced Placement Physics 2**
Grade 12, University Preparation

This course enables students to deepen their understanding of physics concepts and theories. Students will continue their exploration of energy transformations and the forces that affect motion, and will investigate electrical, gravitational, and magnetic fields and electromagnetic radiation. Students will also explore the wave nature of light, quantum mechanics, and special relativity. They will further develop their scientific investigation skills, learning, for example, how to analyze, qualitatively and quantitatively, data related to a variety of physics concepts and principles. Students will also consider the impact of technological applications of physics on society and the environment. AP Physics 2 is an algebra-based, introductory university-level physics course that explores topics such as fluid statics and dynamics; thermodynamics with kinetic theory; PV diagrams and probability; electrostatics; electrical circuits with capacitors; magnetic fields; electromagnetism; physical and geometric optics; and quantum, atomic, and nuclear physics. Through inquiry-based learning, students will develop scientific critical thinking and reasoning skills.

Students will also study the Ontario curriculum for SPH4U and will receive the SPH4U credit on their transcript. They will write the AP Physics 2 exam in May.

Prerequisite: Advanced Placement Physics 1, Grade 11, University Placement
Selection Criteria: Minimum 90% in SPH3U or successful completion of SPH3UAP,
recommendation of teacher and department chair.

Course Fee: \$400 (AP
exam and textbook fee)

STEM

What is STEM Education?

“STEM education is an interdisciplinary approach to learning where rigorous academic concepts are coupled with real-world lessons as students apply science, technology, engineering, and mathematics in contexts that make connections between school, community, work, and the global enterprise enabling the development of STEM literacy and with it the ability to compete in the new economy.” (Tsupros, 2009)

What are the benefits of STEM?

The students most likely to major in STEM fields in university and persist to earn their degrees are those who develop interests in STEM careers through early career planning and take challenging classes that prepare them for university-level science and math coursework. The functions of a STEM education allow students to become problem-solvers, innovators, inventors, self-reliant, logical thinkers, and technologically literate.

This approach allows students to explore mathematics and science in a more personalized context, while helping them to develop the critical thinking skills that can be applied to all facets of their academic lives and future work.

Villanova College will build on its vision to develop STEM programs, partnerships, and experiences. Through this program, students will graduate proficient and engaged in the STEM disciplines while being prepared and inspired to pursue STEM-related studies at the university level.

The STEM Program

The STEM program offers a unique opportunity to engage a select group of highly motivated students in advanced and accelerated studies in science, mathematics, technology, and design. The rigorous hands-on project-based curriculum leverages industry grade software to integrate with classroom data collection and control devices as real-world applications and problems are explored. The STEM program is designed to challenge students and promote their critical thinking and problem-solving skills that can be applied to all facets of their current and future academic and work experiences.

Grade 9 students who enroll in the program will take a common core of courses in Grades 9, 10 and 11 focused on preparing them for Advanced Placement studies in Grade 12.

STEM Selection Criteria

The following criteria will be used to select students who apply to the STEM program:

- above grade level performance in the pre-requisite subject
- a desire and aptitude to be in an advanced and independent learning environment as demonstrated through the student’s learning skills
- recommendation of teacher and input from Student Services

- attendance
- SSAT Placement Test for Grade 9 applicants to STEM

Villanova College STEM Course Selection Planning Chart

Grade 9	Grade 10	Grade 11	Grade 12*
ENL1W	ENG2D	ENG3U	ENG4U
MTH1W – Stem	MPM2D - Stem	MHF4U - Stem	MCV4U – Advanced Placement
SNC1W - Stem	MCR3U - Stem	SPH3U – Advanced Placement	HRE4M/HRE4M1/HZT4U
FSF1D	SNC2D – Stem	SCH3U – Pre-AP	Compulsory*
PPL1O	CHC2D	HRT3M	Compulsory*
CGC1W	HRE2E	Elective	Elective
HRE13	CHV2O/GLC20	Elective	Elective or Study Hall
Arts or Technology Elective	Elective**	Elective	Elective or Study Hall

*Grade 12 STEM students must choose 2 of the following AP courses:

- Biology (SBI4U)
- Chemistry (SCH4U)
- Physics (SPH4U)
- Mathematics of Data Management (MDM4U)

**By the end of Grade 10, all students must complete 1 Arts and 1 Technology credit. If the STEM student has completed these 2 requirements, they can select a course from the list of grade 10 elective course offerings.

The Ontario Student Transcript and AP and STEM Courses

The Ontario Student Transcript (OST) can only include grades for courses that are part of the Ontario curriculum. As a result, AP and STEM courses will not be indicated on the OST. The curriculum expectations assessed as part of the corresponding Ontario curriculum course will be reported on the OST.

STEM Course Descriptions

MCR3U Functions
Grade 11, University Preparation, STEM

This course introduces the mathematical concept of the function by extending students' experiences with linear and quadratic equations. Students will investigate properties of discrete and continuous functions, including trigonometric and exponential functions; represent functions numerically, algebraically, and graphically; solve problems involving applications of functions; investigate inverse functions; and develop facility in determining equivalent algebraic expressions. Students will reason mathematically and communicate their thinking as they solve multi-step problems.
Prerequisite: Principles of Mathematics, Grade 10, STEM

Note: Students are enrolled in MPM2D until the end of January at which time they will write the MPM2D exam. Students are then enrolled in MCR3U from February to June and will write the MCR3U exam in June. Students will earn two high school credits as these are semestered courses.

MCV4U Advancement Placement Calculus AB
Grade 12, University Preparation

This course builds on students' experience with functions and their developing understanding of rates of change. Students will solve problems involving geometric and algebraic representations of vectors, and representations of lines and planes in three-dimensional space; broaden their understanding of rates of change to include the derivatives of polynomial, sinusoidal, exponential, rational and radical functions; and apply these concepts and skills to the modeling of real-world relationships. Students will also refine their use of the mathematical processes necessary for success in senior mathematics. This course is intended for students who choose to pursue careers in fields such as science, engineering, economics, and some areas of business including those students who will be required to take a university-level calculus, linear algebra, or physics course. This course is primarily concerned with developing student understanding of the concepts of calculus and providing experience with its methods and applications. The course emphasizes a multi-representational approach to calculus, with concepts, results, and problems being expressed graphically, numerically, analytically, and verbally. Students will solve problems involving geometric and algebraic representations of vectors, and representations of lines and planes in three-dimensional space; broaden their understanding of rates of change to include the derivatives of polynomial, sinusoidal, exponential, rational and radical functions; and apply these concepts and skills to the modeling of real-world relationships. Students will also refine their use of the mathematical processes necessary for success in senior mathematics. This course is intended for students who choose to pursue careers in fields such as science, engineering, economics, and some areas of business including those students who will be required to take a university-level calculus, linear algebra, or physics course.

Prerequisite: Pre-AP Advanced Functions, Grade 12

Course Fee: \$150 CND (AP Exam fee)

MHF4U Pre-Advancement Placement Advanced Functions
Grade 12, University Preparation

This course extends students' experience with functions. Students will investigate the properties of polynomial, rational, logarithmic, and trigonometric functions; develop techniques for combining functions; broaden their understanding of rates of change; and develop facility in applying these concepts and skills. Student will also refine their use of the mathematical processes necessary for success in senior mathematics. This course is intended both for students taking the Calculus and Vectors course as a prerequisite for a university program and for those wishing to consolidate their understanding of mathematics before proceeding to any one of a variety of university programs.

Prerequisite: Functions, Grade 11, University Preparation, STEM

MTH1W Principles of Mathematics
Grade 9, Academic, STEM

This course enables students to develop an understanding of mathematical concepts related to algebra, analytic geometry, and measurement and geometry through investigation, the effective use of technology, and abstract reasoning. Students will investigate relationships, which they will then generalize as equations of lines, and will determine the connections between different representations of a linear relation. They will also explore relationships

that emerge from the measurement of three-dimensional figures and two-dimensional shapes. Students will reason mathematically and communicate their thinking as they solve multi-step problems. Mathematics and science proficiency are essential to all successful STEM learning. This course will provide an interdisciplinary and applied approach to mathematics – allowing students to integrate content, interpret and communicate information, engage in inquiry, reason logically, apply technology, and collaborate as a team. Students will investigate relationships, which they will then generalize as equations of lines, and will determine the connections between different representations of a linear relation. They will also explore relationships that emerge from the measurement of three-dimensional figures and two-dimensional shapes. To deepen their understanding of mathematics and science, students will acquire and develop the ways of thinking, mental habits, and research techniques drawn upon by mathematicians and scientists.

Prerequisite: SSAT Placement Test and Admission to STEM program

MPM2D Principles of Mathematics
Grade 10, Academic, STEM

This course enables students to broaden their understanding of relationships and extend their problem-solving and algebraic skills through investigation, the effective use of technology, and abstract reasoning. Students will explore quadratic relations and their applications; solve and apply linear systems; verify properties of geometric figures using analytic geometry; and investigate the trigonometry of right and acute triangles. Students will reason mathematically and communicate their thinking as they solve multi-step problems. This course will provide an interdisciplinary and applied approach to mathematics – allowing students to integrate content, interpret and communicate information, engage in inquiry, reason logically, apply technology, and collaborate as a team. Students will pose, formulate, solve, and interpret solutions to mathematical problems in a variety of situations. Students will explore quadratic relations and their applications; solve and apply linear systems; verify properties of geometric figures using analytic geometry; and investigate the trigonometry of right and acute triangles. This course enables students to broaden their understanding of relationships and extend their problem-solving and algebraic skills through investigation, the effective use of technology, and abstract reasoning.

Prerequisite: Principles of Mathematics, Grade 9, STEM

SCH3U Pre-Advancement Placement Chemistry
Grade 11, University Preparation

This course enables students to deepen their understanding of chemistry through the study of the properties of chemicals and chemical bonds; chemical reactions and quantitative relationships in those reactions; solutions and solubility; and atmospheric chemistry and the behaviour of gases. Students will further develop their analytical skills and investigate the qualitative and quantitative properties of matter, as well as the impact of some common chemical reactions on society and the environment.

Prerequisite: Science, Grade 10, Academic, STEM

SNC1W Science
Grade 9, Academic, STEM

This course enables students to develop their understanding of basic concepts in biology, chemistry, earth and space science, and physics, and to relate science knowledge to technology, society, and the environment. Throughout the course, students will develop their skills in the processes of scientific investigation. Students will acquire an

understanding of scientific theories and conduct investigations related to sustainable ecosystems, atomic and molecular structures, and the properties of elements and compounds, the study of the universe and its properties and components; and the principles of electricity. Science is the study of the natural world, including the laws of nature associated with physics, chemistry, and biology and the treatment or application of facts, principles, concepts, or conventions associated with these disciplines. This course will enable students to develop their understanding of scientific concepts and to relate science knowledge to technology, society, and the environment. Students will develop the skills required for scientific inquiry which progresses through a continuous process of questioning, data collection, analysis and interpretation. Working collaboratively with others not only enhances the understanding of science, it also fosters the practice of many of the skills, attitudes, and values that characterize science. Critical thinking skills will be developed as student's study science-related issues and pose and evaluate arguments based on evidence.

Prerequisite: SSAT Placement Test and Admission to STEM program

SNC2D Science
 Grade 10, Academic, STEM

This course enables students to enhance their understanding of concepts in biology, chemistry, earth and space science, and physics, and of the interrelationships between science, technology, society, and the environment. Students are also given opportunities to further develop their scientific investigation skills. Students will plan and conduct investigations and develop their understanding of scientific theories related to the connections between cells and systems in animals and plants; chemical reactions, with a particular focus on acid-base reactions; factors that affect climate and climate change; and the interaction of light and matter.

Prerequisite: Science, Grade 9, STEM

SPH3U Advancement Placement Physics 1
 Grade 11, University Preparation

This course develops students' understanding of the basic concepts of physics. Students will explore kinematics, with an emphasis on linear motion; different kinds of forces; energy transformations; the properties of mechanical waves and sound; and electricity and magnetism. They will enhance their scientific investigation skills as they test laws of physics. In addition, they will analyze the interrelationships between physics and technology, and consider the impact of technological applications of physics on society and the environment. AP Physics 1 is an algebra-based, introductory university-level physics course that explores topics such as Newtonian mechanics (including rotational motion); work, energy, and power; mechanical waves and sound; and introductory, simple circuits. Through inquiry-based learning, students will develop scientific critical thinking and reasoning skills.

Prerequisite: Science, Grade 10, STEM

Course Fee: \$400 (AP exam and textbook fee)

SUPPORT FOR STUDENTS

The Teacher-Advisor and Guidance Counselling

Each student at Villanova College will be assigned to a teacher-advisor who will maintain regular contact with the student throughout their high school career and will be a key contact for parents. The teacher-advisor program in Grade 9 focuses on the transition into high school. In Grades 10, 11 and 12, the focus is on Unitas, Veritas and Caritas.

The Guidance Counsellors of Villanova College are available for social and emotional support. If the student's issue needs further support, a referral will be made to an outside agency to ensure the needs of the student are met.

Guidance and Career Education

The school will assist students in the process of determining both their short and long-term academic goals, to select the most appropriate range of courses to meet those goals, as well as to provide them with opportunities to discuss career planning. This program is delivered through various means such as classroom instruction, the teacher-advisor program, orientation and exit programs, career exploration activities, individual assistance and short-term counselling.

The Guidance Counsellors of Villanova College are prepared to assist students with uncovering their passion and interests at the post-secondary level. Workshops will be provided to ensure that students have all the available information to make an informed decision about college and university, as well as workplace programs. A student's individual pathway will be developed using Xello to map out course selections over the course of their high school experience.

Balanced Curriculum

At all grade levels, the core curriculum is emphasized. We believe that students should enroll in the broadest range of courses. The maintenance of a balanced program provides the student with the widest range of post-secondary options. Cross-disciplinary learning is encouraged and promoted through in-class and field trip activities.

Class Size

Villanova College's mission statement to develop the student as a whole person is best served with small class sizes that foster individual attention and a comfortable learning environment. Class size at Villanova College will rarely exceed 22 students and where sufficient demand exceeds that limit, the course will be divided into multiple sections.

Technology Laptop Program

With our campus-wide wireless network, Villanova College is committed to developing and integrating technology to cultivate critical thinking skills, nurture creativity and enhance learning. Students from Grades 7-12 participate in our wireless Windows-based laptop program. Our Educational Technology plan continues to emphasize the development of organizational skills, technological literacy, and the use of project-based learning. Classrooms are digitally equipped to

be interactive, and we continue to explore the best educational resources including e-texts, OneNote, and specialized software.

Villanova ensures that the minimum hardware and software requirements for all courses for each student are installed on all student devices at the start of the year by the IT department. The minimum hardware requirement for all PC devices in our 1 to 1 program from grades 9 to 12 are as followed. 8 gigabytes of ram, 256 hard drive and I5 processor or later with Windows 10 Home or Pro.

Tutorials

Tutorial assistance for students who require help in areas of difficulty or for personal enrichment is available daily immediately after classes. At the beginning of each term, students are given the opportunity to attend on a voluntary basis. However, where a student demonstrates a weakness in study habits and/or background skills, teachers, in consultation with parents, may make tutorials mandatory until such time as the problem(s) has been addressed to the satisfaction of the parent and the teacher.

Interventions

Students who are at risk of not graduating will be counselled by either a guidance counsellor, and/or a school administrator. Support measures may include extensions on assignments, offering tutorials after school, or encouraging parents to seek a private tutor.

Supports for English Language Learners

Villanova College offers English language learners access to a full complement of services, including ESL classes, E-study and After School Tutorials personalized to each student's proficiency level. Students may use dictionaries, if prescribed by the teacher, on assessments and other accommodations to ensure student success.

Special Education Accommodations

The Guided Learning Centre (GLC) provides identified students with necessary supports to help them achieve their potential. Students who are part of the GLC learn and develop strategies to support them in areas such as reading, writing, math, time management, organization, and studying. Students will gradually learn how to become self-sufficient learners who have confidence in their ability to achieve their goals. Accommodations and supports may include:

- Detailed Individual Education Plans (IEP) for each student
- One-on-one weekly individual meetings with students for support with:
- Chunking of assignments and studying
- Monitoring of assignment and studying progress
- Further development of time management, organization, and study strategies
- Before and after school homework and assignment support
- Quiet and supportive test/exam environment
- Assistive technology supports for eligible students
- Learning Strategies courses taught by our Guided Learning Teachers

STUDENT SERVICES POLICIES & ACCESS TO INFORMATION

Substitutions for Compulsory Credits

To meet the needs of individual students, Head of Upper School may replace up to three compulsory credit courses (or the equivalent in half courses) with courses from the remainder of those that meet the compulsory credit requirements. The Head of Upper School will make the decision in consultation with the parent and the appropriate school staff. Each substitution will be noted on the student's Ontario Student Transcript (OST).

Waiving Prerequisites

For some courses, the Ontario Ministry of Education requires students to successfully complete a preceding lower-level course. If a parent requests that a prerequisite be waived, the sole decision will rest with the Head of Upper School who may consult with the parent and appropriate faculty members. The Head of Upper School will require sufficient evidence to suggest the student has the skills necessary for success in the desired course. Approval forms will be given to the student by Student Services and will require signatures from both the student and the parent, and will need to be returned to Student Services. The forms will then be signed by the subject teacher, Department Chair, Guidance Counsellor, and Administrator, and will be kept on file within the student's OSR.

Course Selection & Course Changes

The school timetable is built according to the course option sheets submitted by the due date of January 30th, 2026 for all students. **If an elective course cannot be scheduled, the alternate course will automatically be used. Students who enroll in these courses will not be allowed to drop them after course decisions have been made.** It is imperative that students choose their courses carefully as changes will only be made after the timetable has been built and in the following circumstances:

- space is available in the requested course, and it can be timetabled into a student's schedule
- a course change form, signed by a parent, is submitted, and approved by Student Services
- after June 1, 2026, course changes will only be considered between August 24th – September 18th, 2026

Student Service counsellors are available to all students to help them make wise and appropriate choices based on their skills, abilities, and interests.

Other considerations when choosing your courses:

- All Senior Math and Science courses require a 70% minimum mark at midterm to be considered for enrollment for the following year.
- Class sizes are limited to 20 students in Technological Design and Communication Technology courses.
- Elective courses must have a minimum of 15 students registered by the course option sheet deadline of January 30, 2026 to be considered for the timetable.
- University planning. Please refer to www.ontariouniversitiesinfo.ca for further information including entrance

averages, prerequisites, and recommended courses for Ontario universities.

- College planning. Please refer to www.ontariocolleges.ca for further information including entrance averages, prerequisites and recommended courses for Ontario colleges.
- Parents and students can access the Ontario curriculum at <http://www.edu.gov.on.ca/eng/curriculum/secondary/>.

Non-Villanova College Credit Policies and Procedures

Enrichment credits, taken in addition to the regular course load, may be taken elsewhere. All credits taken outside Villanova College must be offered by an institution inspected by the Ontario Ministry of Education who will issue an official report card at the completion of the course. The successful completion of these credit courses will be added to the student's official transcript once a copy of the report card is submitted to Student Services. Please note, it is the student's responsibility to acquire and submit the report card. **Courses taken outside of Villanova College will not be included in honour's society calculations and Villanova College award considerations.**

Enrichment credits do not relieve students of the normal course load at Villanova College—8 courses per year in Grades 9, 10 and 11. Students in Grade 12, in consultation with Student Services and their parents, may be allowed to take 6, Grade 12 credits, if they have completed an enrichment Grade 12 course prior to their Grade 12 year.

Students wishing to enroll in overseas or other summer programs should see Student Services prior to committing to another program. All outside courses must be approved by the Head of Upper School. Permission must be granted for the course prior to enrollment to assure that the credit is acceptable. **Failure to receive permission from the Head of Upper School may jeopardize your enrollment at Villanova College.**

To seek approval for an outside credit, please adhere to the following steps:

1. Make an appointment with Student Services to discuss the course/program you are proposing to take. Bring all printed information about the program with you.
2. Complete the Request to Enrol in Outside Courses form online (refer to the Documents folder in Edsby).
3. Assessment of the course/credit/program will determine whether it will be approved.
4. Students Services will bring it to the attention of the Head of Upper School if it is necessary for final approval.
5. Register in the program if approved. Villanova College will keep a copy of the registration material.

Ontario Student Transcript (OST)

The Ontario Student Transcript provides an official record of the following:

- all Grade 9 and 10 courses successfully completed by the student, with percentage grades obtained and credits earned
- all Grade 11 and 12 courses completed or attempted by the student, with percentage grades obtained and credits earned
- identification of compulsory credits, including credits that are substitutions for compulsory credits identified by the Ministry of Education as diploma requirements

- confirmation that the student has completed the 40 hours of community involvement
- confirmation that the student has successfully completed the provincial Ontario Secondary School Literacy Test, and
- a record of achievement of exceptional students who have alternative learning expectations in an individualized, non-credit program

The Ontario Student Transcript Manual, 2010 outlines the regulations and procedures to be followed in completing the OST for students who withdraw from a course that they have previously completed successfully. They are as follows:

Withdrawals from Grade 9 and 10 courses are not recorded on the OST. Only successfully completed courses are recorded on the OST.

If a student withdraws from a Grade 11 or 12 course within five instructional days following the issue of the second provincial report card in a non-semestered school, the withdrawal is not recorded on the OST. If a student withdraws from a course after five instructional days following the issue of the second provincial report card in a non-semestered school, the withdrawal is recorded on the OST by entering a “W” in the “Credit” column. The student’s percentage grade at the time of the withdrawal is recorded in the “Percentage Grade” column.

Students who repeat a Grade 11 or 12 course that they have previously completed successfully earn only one credit for the course. However, each attempt as well as the percentage grade obtained, is recorded on the OST and an “R” is entered in the “Credit” column for the course(s) with the lower percentage grade.

At Villanova College students will not be permitted to withdraw from a course in Grades 9, 10 or 11 unless the course can be replaced by another course in the current school year. All changes in a student’s timetable must be made in consultation with the parents, the student, Student Services and the Head of Upper School. The Head of Upper School will ensure that each student’s timetable meets the expectations and mission statement of Villanova College. The Ontario Student Transcript is updated annually and is part of the Ontario Student Record (OSR).

Ontario Student Record (OSR)

The Ontario Student Record (OSR) is the confidential record of a student’s educational progress throughout his/her school career. The collection of this information, which is authorized by the Education Act, is filed in the school’s Student Services Office. All students, and parents of students under the age of 18, have a right to examine the OSR and to receive a copy of its contents.

To examine an OSR at Villanova College, the following procedures must be followed:

- A written request to examine the OSR must be forwarded to the Head of Upper School.
- Students under 18 years of age must be accompanied by a parent to examine the documents; an appointment will be made within one week of the written request, with the Head of Upper School to view the OSR; copies of any of its contents must be documented and signed as received by the parents of students less than 18 years of age; students 18 years of age and older, still living at home and attending Villanova must allow their parents access to the contents of the OSR for examination.

VILLANOVA COLLEGE SUMMER SCHOOL

Summer School Program 2026

Monday, June 29 – Monday, July 20, 2026

8:30 am – 3:40 pm

Students are not allowed to miss any school days during our Summer School program.

Please see Edsby or the Villanova College website for registration and payment information in late January.

Students currently in Grade 8 may enroll in the Careers and Civics courses or Technology. This will allow them to take an extra elective of their choice in their Grade 10 year.

Summer Upper School Academic Credits

Students wishing to try a wider variety of courses or establish prerequisites for Grade 12 or university programs may wish to take a course in the summer. This allows them to have a wider range of options when making decisions for their university program and allows students to put off narrowing their choices until they have experienced more course material. **Summer school courses will not be included in your Villanova College report card average, and the final mark will not be considered for any Villanova College Academic Awards.** Summer school marks are eligible to be included for university and college acceptance averages.

Students are not permitted to take compulsory courses in summer school except for Careers and Civics.

Upper School Summer Course Offerings

For Students Entering Grade 9 in September 2026	For Students Entering Grade 10 in September 2026	For Students Entering Grade 11 in September 2026	For Students Entering Grade 12 in September 2026
<ul style="list-style-type: none">• CHV20 Civics & GLC20 Careers• TAS10 Technology and the Skilled Trades	<ul style="list-style-type: none">• CHV20 Civics & GLC20 Careers• TAS10 Technology and the Skilled Trades• MTH1W2 Math Recovery• MTH1W3 Math Upgrading	<ul style="list-style-type: none">• SBI3U Biology• MPM2D2 Math Recovery• MPM2D3 Math Upgrading	<ul style="list-style-type: none">• MHF4U Advanced Functions

Grade 9

MTH1W2	Mathematics - Recovery
55 hours	Grade 9, Destreamed

This course will review, develop and strengthen the grade 9 mathematical concepts related to algebra, analytic geometry, and measurement and geometry through investigation, the effective use of technology, and abstract reasoning. Students taking this course were unsuccessful in achieving the credit in their first attempt. With the help of a math learning plan as developed by the subject teacher, students will investigate relationships, which they will then generalize as equations of lines, and will determine the connections between different representations of a linear relation. They will also explore relationships that emerge from the measurement of three-dimensional figures and two-dimensional shapes. Students will reason mathematically and communicate their thinking as they solve multi-step problems.

Prerequisite: First attempt at MTH1W during the school year.

MTH1W3	Mathematics - Upgrading
55 hours	Grade 9, Destreamed

This course will review, develop and strengthen the grade 9 mathematical concepts related to algebra, analytic geometry, and measurement and geometry through investigation, the effective use of technology, and abstract reasoning. Students taking this course were successful in achieving the credit in their first attempt but did not meet the academic threshold of 65%. With the help of a math learning plan as developed by the subject teacher, students will investigate relationships, which they will then generalize as equations of lines, and will determine the connections between different representations of a linear relation. They will also explore relationships that emerge from the measurement of three-dimensional figures and two-dimensional shapes. Students will reason mathematically and communicate their thinking as they solve multi-step problems.

Prerequisite: First attempt at MTH1W during the school year.

TAS10	Technology and the Skilled Trades
	Grade 9, Open

This hands-on course enables students to further explore the engineering design process and develop other technological knowledge and skills introduced in earlier grades. Students will design and safely create prototypes, products, and/or services, working with tools and technologies from various industries. As students develop their projects to address real-life problems, they will apply technological concepts such as precision measurement, as well as health and safety standards. Students will begin to explore job skills programs and education and training pathways, including skilled trades, that can lead to a variety of careers.

Prerequisite: None

Grade 10

CHV20 (.5 credit)	Civics
55 hours	Grade 10, Open

This course explores rights and responsibilities associated with being an active citizen in a democratic society. Students will explore issues of civic importance and the influence of social media, while developing their

understanding of the role of civic engagement and of political processes in the local, national, and/or global community. Students will apply the concepts of political thinking and the political inquiry process to investigate, and express informed opinions about, a range of political issues and developments that are both of significance in today's world and of personal interest to them. This course also includes learning on digital literacy and critical-thinking skills, the mechanisms of government, Indigenous governance systems and structures, the historical foundations of the rights and freedoms we enjoy in Canada, ways in which government policy affects individuals' lives and the economy, and ways for students to serve their communities.

Prerequisite: None

GLC20 (0.5 credit)
55 hours

Career Studies
Grade 10, Open

This course gives students the opportunity to develop the skills, knowledge, and habits that will support them in their education and career/life planning. Students will learn about global work trends, and seek opportunities within the school and community to expand and strengthen their transferable skills and their ability to adapt to the changing world of work. On the basis of exploration, reflective practice, and decision-making processes, students will make connections between their skills, interests, and values and their postsecondary options, whether in apprenticeship training, college, community living, university, or the workplace. They will set goals and create a plan for their first postsecondary year. As part of their preparation for the future, they will learn about personal financial management – including the variety of saving and borrowing tools available to them and how to use them to their advantage – and develop a budget for their first year after secondary school.

Prerequisite: None

MPM2D2

Mathematics - Recovery
Grade 10, Academic

This course will review, develop, and strengthen students' understanding of relationships and extend their problem-solving and algebraic skills through investigation, the effective use of technology, and abstract reasoning. Students taking this course were unsuccessful in achieving the credit in their first attempt. With the help of a math learning plan as developed by the subject teacher, the summer schoolteacher will focus on specific expectations and concepts that will explore quadratic relations and their applications; solve and apply linear systems; verify properties of geometric figures using analytic geometry; and investigate the trigonometry of right and acute triangles. Students will reason mathematically and communicate their thinking as they solve multi-step problems.

Prerequisite: First attempt at MPM2D during the school year.

MPM2D3

Mathematics - Upgrading
Grade 10, Academic

This course will review, develop, and strengthen students' understanding of relationships and extend their problem-solving and algebraic skills through investigation, the effective use of technology, and abstract reasoning. Students taking this course were successful in achieving the credit in their first attempt but did not meet the academic threshold of 65%. With the help of a math learning plan as developed by the subject teacher, the summer schoolteacher will focus on specific expectations and concepts that will explore quadratic relations and their applications; solve and apply linear systems; verify properties of geometric figures using analytic geometry; and

investigate the trigonometry of right and acute triangles. Students will reason mathematically and communicate their thinking as they solve multi-step problems.

Prerequisite: First attempt at MPM2D during the school year.

Grade 11

SBI3U Biology
Grade 11, University Preparation

This course furthers students' understanding of the processes involved in biological systems. Students will study cellular functions, genetic continuity, internal systems and regulation, the diversity of living things, and the anatomy, growth, and functions of plants. The course focuses on the theoretical aspects of the topics under study, and helps students refine skills related to scientific investigation.

Prerequisite: Science, Grade 10, Academic

Grade 12

MHF4U Advanced Functions
Grade 12, University Preparation

This course extends students' experience with functions. Students will investigate the properties of polynomial, rational, logarithmic, and trigonometric functions; develop techniques for combining functions; broaden their understanding of rates of change; and develop facility in applying these concepts and skills. Student will also refine their use of the mathematical processes necessary for success in senior mathematics. This course is intended both for students taking the Calculus and Vectors course as a prerequisite for a university program and for those wishing to consolidate their understanding of mathematics before proceeding to any one of a variety of university programs.

Prerequisite: Functions, Grade 11, University Preparation

English and Math Skills Development Program for Middle School Students

A morning program from June 30 - July 21 (8:30 a.m. -11:15 a.m.).

This program is designed for students to strengthen their literacy, numeracy, and learning skills in English and Math to ensure success in the coming academic year. This morning program is available to students currently in Grades 3-8.

COURSE DESCRIPTIONS GRADES 9-12

The Arts

Mission Statement: We believe student need and deserve a high-quality Fine Arts education. We strive to inspire each child to become a creative and innovative thinker through our comprehensive programs. Our primary focus on reaching high levels of achievement and competence in the Arts is to provide students with the essential skills that are critical to their success while fostering an environment where their unique talents and perspectives can emerge and flourish.

AMU10 Music
Grade 9, Open

This course emphasizes the creation and performance of music at a level consistent with previous experience and is aimed at developing technique, sensitivity, and imagination. Students will develop musical literacy skills by using the creative and critical analysis processes in composition, performance, and a range of reflective and analytical activities. Students will develop an understanding of the conventions and elements of music and of safe practices related to music and will develop a variety of skills transferable to other areas of their life.

Prerequisite:None

Course Fee: \$40.00

AMU20 Music
Grade 10, Open

This course emphasizes the creation and performance of music at a level consistent with previous experience. Students will develop musical literacy skills by using the creative and critical analysis processes in composition, performance, and a range of reflective and analytical activities. Students will develop their understanding of musical conventions, practices, and terminology and apply the elements of music in a range of activities. They will also explore the function of music in society with reference to the self, communities, and cultures.

Prerequisite: None

Course Fee: \$40.00

AMU3M Music
Grade 11, University/College Preparation

This course provides students with opportunities to develop their musical literacy through the creation, appreciation, analysis, and performance of music, including traditional, commercial, and art music. Students will apply the creative process when performing appropriate technical exercises and repertoire and will employ the critical analysis processes when reflecting on, responding to, and analyzing live and recorded performances. Students will consider the function of music in society and the impact of music on individuals and communities. They will explore how to apply skills developed in music to their life and careers.

Prerequisite: Music, Grade 9 or 10 Open

Course Fee: \$40.00

AMU4M **Music**
Grade 12, University/College Preparation

This course enables students to enhance their musical literacy through the creation, appreciation, analysis, and performance of music. Students will perform traditional, commercial, and art music, and will respond with insight to live and recorded performances. Students will enhance their understanding of the function of music in society and the impact of music on themselves and various communities and cultures. Students will analyze how to apply skills developed in music to their life and careers.

Prerequisite: Music, Grade 11, University/College Preparation

Course Fee: \$40.00

AMR4M **Music Repertoire**
Grade 12, University/College Preparation

This course enables students to enhance their musical literacy through the creation, appreciation, analysis, and performance of music. Students will perform traditional, commercial, and art music, and will respond with insight to live and recorded performances. Students will enhance their understanding of the function of music in society and the impact of music on themselves and various communities and cultures. Students will explore and perform University level repertoire. Students will analyze how to apply skills developed in music to their life and careers.

Prerequisite: Music, Grade 12, University/College Preparation – AMU4M

Course Fee: \$40.00

AV10 **Visual Arts**
Grade 9, Open

This course is exploratory in nature, offering an overview of visual arts as a foundation for further study. Students will become familiar with the elements and principles of design and the expressive qualities of various materials by using a range of media, processes, techniques, and styles. Students will use the creative and critical analysis processes and will interpret art within a personal, contemporary, and historical context.

Prerequisite: None

Course Fee: \$100.00

AV20 **Visual Arts**
Grade 10, Open

This course enables students to develop their skills in producing and presenting art by introducing them to new ideas, materials, and processes for artistic exploration and experimentation. Students will apply the elements and principles of design when exploring the creative process. Students will use the critical analysis process to reflect on and interpret art within a personal, contemporary, and historical context.

Prerequisite: None

Course Fee: \$100.00

AVI3M Visual Arts
Grade 11, University/College Preparation

This course enables students to further develop their knowledge and skills in visual arts. Students will use the creative process to explore a wide range of themes through studio work that may include drawing, painting, sculpting, and printmaking, as well as the creation of collage, multimedia works, and works using emergent technologies. Students will use the critical analysis process when evaluating their own work and the work of others. The course may be delivered as a comprehensive program or through a program focused on a particular art form (e.g. photography, video, computer graphics, and information design).

Prerequisite: Grade 9 or 10 Visual Arts, Open

Course Fee: \$100.00

AVI4M Visual Arts
Grade 12, University/College Preparation

This course focuses on enabling students to refine their use of the creative process when creating and presenting two- and three-dimensional art works using a variety of traditional and emerging media and technologies. Students will use the critical analysis process to deconstruct art works and explore connections between art and society. The studio program enables students to explore a range of materials, processes, and techniques that can be applied in their own art production. Students will also make connections between various works of art in personal, contemporary, historical, and cultural contexts.

Prerequisite: Visual Arts, Grade 11, University/College Preparation

Course Fee: \$100.00

Business Studies

Mission Statement: The Mathematics, Business, Design, Computer Science and Communications Technology Department is dedicated to preparing students for a rapidly changing world by expanding each student's knowledge and skills. It is our goal to have our students understand and appreciate the concepts they are studying; that they can read, write, explore, and communicate these concepts with confidence; and that they value the ability to use them, as needed, in their lives. It is our belief that the knowledge, skills and ethics taught are necessary for active, life-long participation in a global society—fostering success in one's personal life, post-secondary study, and career choice.

BAF3M Financial Accounting Fundamentals Grade 11, University/College Preparation

This course introduces students to the fundamental principles and procedures of accounting. Students will develop financial analysis and decision-making skills that will assist them in future studies and/or career opportunities in business. Students will acquire an understanding of accounting for a service and a merchandising business, computerized accounting, financial analysis, and ethics and current issues in accounting.

Prerequisite: None

BAT4M Financial Accounting Grade 12, University/College Preparation

This course introduces students to advanced accounting principles that will prepare them for postsecondary studies in business. Students will learn about financial statements for various forms of business ownership and how those statements are interpreted in making business decisions. This course expands students' knowledge of sources of financing, further develops accounting methods for assets, and introduces accounting for partnerships and corporations.

Prerequisite: Financial Accounting Fundamentals, Grade 11, University/College Preparation

BBB4M International Business Fundamentals Grade 12, University/College Preparation

This course provides an overview of the importance of international business and trade in the global economy and explores the factors that influence success in international markets. Students will learn about the techniques and strategies associated with marketing, distribution, and managing international business effectively. This course prepares students for postsecondary programs in business, including international business, marketing, and management.

Prerequisite: None

BEP2O **Launching and Leading a Business**
Grade 10, Open

This course introduces students to the world of business and what is required to be successful, ethical, and responsible in today's economy. Students will develop the knowledge and skills needed to be an entrepreneur who knows how to respond to local and global market opportunities. Throughout the course, students will explore and understand the responsibility of managing different functions of a business. This includes accounting, marketing, information and communication technology, financial management, human resources, and production.

Prerequisite: None

BOH4M **Business Leadership: Management Fundamentals**
Grade 12, University/College Preparation

This course focuses on the development of leadership skills used in managing a successful business. Students will analyze the role of a leader in business, with a focus on decision making, management of group dynamics, workplace stress and conflict, motivation of employees, and planning. Effective business communication skills, ethics, and social responsibility are also emphasized.

Prerequisite: None

Canadian and World Studies

Mission Statement: The Canadian and World Studies department is committed to inspiring intellectual curiosity in our students and igniting a passion for learning while developing and honing critical thinking, problem solving and communications skills to prepare students for success in university, the workforce and as global citizens of the 21st century.

CGC1W Issues in Canadian Geography Grade 9, Destreamed

This course examines interrelationships within and between Canada's natural and human systems and how these systems interconnect with those in other parts of the world. Students will explore environmental, economic, and social geographic issues relating to topics such as transportation options, energy choices, and urban development. Students will apply the concepts of geographic thinking and the geographic inquiry process, including spatial technologies, to investigate various geographic issues and to develop possible approaches for making Canada a more sustainable place to live.

Prerequisite: None

CHA3U American History Grade 11, University

This course explores key aspects of the social, economic, and political development of the United States from precontact to the present. Students will examine the contributions of groups and individuals to the country's evolution and will explore the historical context of key issues, trends, and events that have had an impact on the United States, its identity and culture, and its role in the global community. Students will extend their ability to apply the concepts of historical thinking and the historical inquiry process, including the interpretation and analysis of evidence, when investigating various forces that helped shape American history.

Prerequisite: None

CHC2D Canadian History since World War I Grade 10, Academic

This course explores social, economic, and political developments and events and their impact on the lives of different individuals, groups, and communities, including First Nations, Métis, and Inuit individuals and communities, in Canada since 1914. Students will examine the role of conflict and cooperation in Canadian society, Canada's evolving role within the global community, and the impact of various individuals, organizations, and events on identities, citizenship, and heritage in Canada. Students will develop an understanding of some of the political developments and government policies that have had a lasting impact on First Nations, Métis, and Inuit individuals and communities. They will develop their ability to apply the concepts of historical thinking and the historical inquiry process, including the interpretation and analysis of evidence, when investigating key issues and events in Canadian history since 1914.

Prerequisite: None

CHV20 (.5 credit) Civics
55 hours Grade 10, Open

This course explores rights and responsibilities associated with being an active citizen in a democratic society. Students will explore issues of civic importance and the influence of social media, while developing their understanding of the role of civic engagement and of political processes in the local, national, and/or global community. Students will apply the concepts of political thinking and the political inquiry process to investigate, and express informed opinions about, a range of political issues and developments that are both of significance in today's world and of personal interest to them. This course also includes learning on digital literacy and critical-thinking skills, the mechanisms of government, Indigenous governance systems and structures, the historical foundations of the rights and freedoms we enjoy in Canada, ways in which government policy affects individuals' lives and the economy, and ways for students to serve their communities.

Prerequisite: None

CHY4U World History since the 15th Century
Grade 12, University Preparation

This course traces major developments and events in world history since approximately 1450. Students will explore social, economic, and political changes, the historical roots of contemporary issues, and the role of conflict and cooperation in global interrelationships. They will extend their ability to apply the concepts of historical thinking and the historical inquiry process, including the interpretation and analysis of evidence, as they investigate key issues and assess societal progress or decline in world history.

Prerequisite: Any university or university/college preparation course in Canadian and World Studies, English, or Social Sciences and Humanities

CIE3M The Individual and the Economy
Grade 11, University/College Preparation

This course explores issues and challenges facing the Canadian economy as well as the implications of various responses to them. Students will explore the economic role of firms, workers, and government as well as their own role as individual consumers and contributors, and how all of these roles contribute to stability and change in the Canadian economy. Students will apply the concepts of economic thinking and the economic inquiry process, including economic models, to investigate the impact of economic issues and decisions at the individual, regional, and national level.

Prerequisite: Canadian History since World War I, Grade 10, Academic or Applied

CIA4U Analyzing Current Economic Issues
Grade 12, University Preparation

This course examines current Canadian and international economic issues, developments, policies, and practices from diverse perspectives. Students will explore the decisions that individuals and institutions, including governments, make in response to economic issues such as globalization, trade agreements, economic inequalities, regulation, and public spending. Students will apply the concepts of economic thinking and the economic inquiry process, as well as

economic models and theories, to investigate, and develop informed opinions about, economic trade-offs, growth, and sustainability and related economic issues.

Prerequisite: Any university or university/college preparation course in Canadian and World Studies, English, or Social Sciences and Humanities

CLN4U Canadian and International Law
Grade 12, University Preparation

This course explores a range of contemporary legal issues and how they are addressed in both Canadian and international law. Students will develop an understanding of the principles of Canadian and international law and of issues related to human rights and freedoms, conflict resolution, and criminal, environmental, and workplace law, both in Canada and internationally. Students will apply the concepts of legal thinking and the legal studies inquiry process, and will develop legal reasoning skills, when investigating these and other issues in both Canadian and international contexts.

Prerequisite: Any university or university/college preparation course in Canadian and World studies, English, or Social Sciences and Humanities

CPW4U Canadian and International Politics
Grade 12, University Preparation

This course various perspectives on issues in Canadian and world politics. Students will explore political decision making and ways in which individuals, stakeholder groups, and various institutions, including government, multinational corporations, and non-governmental organizations, respond to and work to address domestic and international issues. Students will apply the concepts of political thinking and the political inquiry process to investigate issues, events, and developments of national and international political importance, and to develop and communicate informed opinions about them.

Prerequisite: Any university or university/college preparation course in Canadian and World studies, English, or Social Sciences and Humanities

Classical Studies and International Languages

Mission Statement: The ability to communicate across national and linguistic borders has become essential in our globalized world. The mission of Villanova's International Languages Department is to help our students develop the linguistic, literary, and cross-cultural competence necessary to live, work, and be lifelong learners, as people of faith in our diverse world.

LWSBD Spanish
Grade 10, Level 1, Academic

This course provides students with the language learning experiences that will enable them to communicate in the language of study. Students will continue to develop and apply their speaking skills in a variety of contexts and will participate in activities that will improve their reading comprehension and writing skills. They will also continue to explore aspects of the culture of countries where the language under study is spoken by taking part in community sponsored events and activities involving both print and technological resources. Although students will continue to expand their vocabulary and repertoire of language structures, the language they will use at this level will still be simple.

Prerequisite: None

LWSCU Spanish
Grade 11, Level 2, University Preparation

This course provides opportunities for students to increase their competence and confidence in listening, speaking, reading, and writing in the language of study. Students will communicate about academic and personally relevant topics in increasingly spontaneous spoken interactions and will develop their creative and critical thinking skills through exploring and responding to a variety of oral and written texts. Students will continue to enrich their understanding and appreciation of diverse communities in regions of the world where the language is spoken. They will also investigate personal and professional contexts in which knowledge of the language is required and develop skills necessary for lifelong language learning.

Prerequisite: Spanish, Level 1, Academic

LWSDU Spanish
Grade 12, Level 3, University Preparation

This course provides extended opportunities for students to communicate and interact in the language of study in a variety of social and academic contexts. Students will refine and enhance their listening, speaking, reading, and writing skills, as well as their creative and critical thinking skills, as they explore and respond to a variety of oral and written texts, including complex authentic and adapted texts. They will also broaden their understanding and appreciation of diverse communities where the language is spoken, and develop skills necessary for lifelong language learning

Prerequisite: Spanish, Level 2, Academic

Cooperative Education

Mission Statement: Cooperative education provides secondary school students with a wide range of rigorous learning opportunities connected to communities outside the school. It is designed to recognize and respond to the diversity of Ontario's student population, and it can engage all students.

DCO30* Creating Opportunities through Co-op Grade 11, Open

This course consists of a learning experience connected to a community and a cooperative education curriculum focused on developing skills, knowledge, and habits of mind that will support students in their learning, including their education and career/life planning, at school and beyond, today and in the future. Within the context of their experience connected to a community, students will apply skills, knowledge, and habits of mind that will protect and promote their health, safety, and well-being and that will strengthen their inquiry, decision-making, and leadership skills. Students will create and implement a learning plan that meets their particular interests and needs, reflect on their learning, and make connections between their experience in the community and other aspects of their lives.

Prerequisite: None

*Villanova College does not offer a co-operative education program.

Computer Studies

Mission Statement: The Mathematics, Business, Design, Computer Science and Communications Technology department is dedicated to preparing students for a rapidly changing world by expanding each student’s knowledge and skills. It is our goal to have our students understand and appreciate the concepts they are studying; that they can read, write, explore, and communicate these concepts with confidence; and that they value the ability to use them, as needed, in their lives. It is our belief that the knowledge, skills and ethics taught are necessary for active, life-long participation in a global society—fostering success in one’s personal life, post-secondary study, and career choice.

ICS3U Introduction to Computer Science Grade 11, University Preparation

This course introduces students to computer science. Students will design software independently and as part of a team, using industry-standard programming tools and applying the software development life-cycle model. They will also write and use subprograms within computer programs. Students will develop creative solutions for various types of problems as their understanding of the computing environment grows. They will also explore environmental and ergonomic issues, emerging research in computer science, and global career trends in computer-related fields.

Prerequisite: None

ICS4U Computer Science Grade 12, University Preparation

This course enables students to further develop knowledge and skills in computer science. Students will use modular design principles to create complex and fully documented programs, according to industry standards. Student teams will manage a large software development project, from planning through to project review. Students will also analyse algorithms for effectiveness. They will investigate ethical issues in computing and further explore environmental issues, emerging technologies, areas of research in computer science, and careers in the field.

Prerequisite: Introduction to Computer Science, Grade 11, University Preparation

English

Mission Statement: It is the mission of Villanova College's English department to cultivate the development of critical thinking and communication skills that will allow students to understand and articulate their value as individuals and their role as Catholic citizens in a global community.

ENL1W English Grade 9, Academic

This course is designed to develop the oral communication, reading, writing, and media literacy skills that students need for success in their secondary school academic programs and in their daily lives. Students will analyze literary texts from contemporary and historical periods, interpret informational and graphic texts, and create oral, written, and media texts in a variety of forms. An important focus will be on the use of strategies that contribute to effective communication. The course is intended to prepare students for the Grade 10 academic English course, which leads to university or college preparation courses in Grades 11 and 12.

Prerequisite: None

ENG2D English Grade 10, Academic

This course is designed to extend the range of oral communication, reading, writing, and media literacy skills that students need for success in their secondary school academic programs and in their daily lives. Students will analyze literary texts from contemporary and historical periods, interpret and evaluate informational and graphic texts, and create oral, written, and media texts in a variety of forms. An important focus will be on the selective use of strategies that contribute to effective communication. This course is intended to prepare students for the compulsory Grade 11 university or college preparation course.

Prerequisite: Grade 9 English, Academic or Applied

ENG3U English Grade 11, University Preparation

This course emphasizes the development of literacy, communication, and critical and creative thinking skills necessary for success in academic and daily life. Students will analyze challenging literary texts from various periods, countries, and cultures, as well as a range of informational and graphic texts, and create oral, written, and media texts in a variety of forms. An important focus will be on using language with precision and clarity and incorporating stylistic devices appropriately and effectively. The course is intended to prepare students for the compulsory Grade 12 university or college preparation course.

Prerequisite: English, Grade 10, Academic

ENG4U English
Grade 12, University Preparation

This course emphasizes the consolidation of the literacy, communication, and critical and creative thinking skills necessary for success in academic and daily life. Students will analyze a range of challenging literary texts from various periods, countries, and cultures; interpret and evaluate informational and graphic texts; and create oral, written, and media texts in a variety of forms. An important focus will be on using academic language coherently and confidently, selecting the reading strategies best suited to particular texts and particular purposes for reading, and developing greater control in writing. The course is intended to prepare students for university, college, or the workplace.
Prerequisite: English, Grade 11, University Preparation

EWC4U The Writer's Craft
Grade 12, University Preparation

This course emphasizes knowledge and skills related to the craft of writing. Students will analyze models of effective writing; using a workshop approach to produce a range of works; identify and use techniques required for specialized forms of writing; and identify effective ways to improve the quality of their writing. They will also complete a major paper as part of a creative or analytical independent study project and investigate opportunities for publication and for writing careers.
Prerequisite: Grade 11 English, University Preparation

OLC40* English
Grade 12, University Preparation

This course is designed to help students acquire and demonstrate the cross-curricular literacy skills that are evaluated by the Ontario Secondary School Literacy Test (OSSLT). Students who complete the course successfully will meet the provincial literacy requirement for graduation. Students will read a variety of informational, narrative, and graphic texts and will produce a variety of forms of writing, including summaries, information paragraphs, opinion pieces, and news reports. Students will also maintain and manage a portfolio containing a record of their reading experiences and samples of their writing.

Eligibility requirement: Students who have been eligible to write the OSSLT at least twice and who have been unsuccessful at least once are eligible to take the course. (Students who have already met the literacy requirement for graduation may be eligible to take the course under special circumstances, at the discretion of the Head of Upper School.)

*The OLC40 course is not offered at Villanova College; however, Student Services will be able to direct students to available programs within the community.

English as a Second Language and English Literacy Development

Mission Statement: It is the mission of the English as a Second Language program to fully integrate international students into the Villanova community by developing English communication skills and the socio-cultural competency necessary to be active and engaged students in and outside the classroom.

ESLBO English as a Second Language Level 2, Open

This course extends students' listening, speaking, reading, and writing skills in English for everyday and academic purposes. Students will participate in conversations in structured situations on a variety of familiar and new topics; read a variety of texts designed or adapted for English language learners; expand their knowledge of English grammatical structures and sentence patterns; and link English sentences to compose paragraphs. The course also supports students' continuing adaptation to the Ontario school system by expanding their knowledge of diversity in their new province and country.

Prerequisite: ESL Level 1 or equivalent. "Equivalent" may be an equivalent course of study in other provinces in Canada or in other countries, or a proficiency level determined through initial assessment.

ESLCO English as a Second Language Level 3, Open

This course further extends students' skills in listening, speaking, reading, and writing in English for a variety of everyday and academic purposes. Students will make short classroom oral presentations; read a variety of adapted and original texts in English; and write using a variety of text forms. As well, students will expand their academic vocabulary and their study skills to facilitate their transition to the mainstream school program. This course also introduces students to the rights and responsibilities inherent in Canadian citizenship, and to a variety of current Canadian issues.

Prerequisite: ESL Level 2 or equivalent. "Equivalent" may be an equivalent course of study in other provinces in Canada or in other countries, or a proficiency level determined through initial assessment.

ESLDO English as a Second Language Level 4, Open

This course prepares students to use English with increasing fluency and accuracy in classroom and social situations and to participate in Canadian society as informed citizens. Students will develop the oral presentation, reading, and writing skills required for success in all school subjects. They will extend listening and speaking skills through participation in discussions and seminars; study and interpret a variety of grade-level texts; write narratives, articles, and summaries in English; and respond critically to a variety of print and media texts.

Prerequisite: ESL Level 3 or equivalent. "Equivalent" may be an equivalent course of study in other provinces in Canada or in other countries, or a proficiency level determined through initial assessment.

This course provides students with the skills and strategies they need to make the transition to college and university preparation courses in English and other secondary school disciplines. Students will be encouraged to develop independence in a range of academic tasks. They will participate in debates and lead classroom workshops; read and interpret literary works and academic texts; write essays, narratives, and reports; and apply a range of learning strategies and research skills effectively. Students will further develop their ability to respond critically to print and media texts.

Prerequisite: ESL Level 3 or equivalent. "Equivalent" may be an equivalent course of study in other provinces in Canada or in other countries, or a proficiency level determined through initial assessment.

French as a Second Language

Mission Statement: The ability to communicate across national and linguistic borders has become essential in our globalized world. The mission of Villanova's International Languages Department is to help our students develop the linguistic, literary, and cross-cultural competence necessary to live, work, and be lifelong learners, as people of faith in our diverse world.

FSF1D Core French Grade 9, Academic

This course provides opportunities for students to communicate and interact in French with increasing independence, with a focus on familiar topics related to their daily lives. Students will develop their skills in listening, speaking, reading, and writing by using language learning strategies introduced in the elementary Core French program, and will apply creative and critical thinking skills in various ways. They will also enhance their understanding and appreciation of diverse French-speaking communities and will develop skills necessary for lifelong language learning.

Prerequisite: Minimum of 600 hours of French instruction, or equivalent

FSF2D Core French Grade 10, Academic

This course provides opportunities for students to communicate in French about personally relevant, familiar, and academic topics in real-life situations with increasing independence. Students will exchange information, ideas, and opinions with others in guided and increasingly spontaneous spoken interactions. Students will develop their skills in listening, speaking, reading, and writing through the selective use of strategies that contribute to effective communication. They will also increase their understanding and appreciation of diverse French-speaking communities and will develop skills necessary for lifelong language learning.

Prerequisite: Core French, Grade 9, Academic or Applied

FSF3U Core French Grade 11, University Preparation

This course offers students extended opportunities to speak and interact in real-life situations in French with greater independence. Students will develop their listening, speaking, reading, and writing skills, as well as their creative and critical thinking skills, through responding to and exploring a variety of oral and written texts. They will also broaden their understanding and appreciation of diverse French-speaking communities and will develop skills necessary for lifelong language learning.

Prerequisite: Core French, Grade 10, Academic

This course provides extensive opportunities for students to speak and interact in French independently. Students will develop their listening, speaking, reading, and writing skills, apply language learning strategies in a wide variety of real-life situations, and develop their creative and critical thinking skills through responding to and interacting with a variety of oral and written texts. They will also enrich their understanding and appreciation of diverse French-speaking communities and will develop skills necessary for lifelong language learning.

Prerequisite: Core French, Grade 11, University Preparation

Guidance and Career Education

Mission Statement: The Student Services Department focuses on providing programs, information, and strategies to help students reach their social, emotional, and academic potential. Through classroom visits, information evenings, individual counselling, and visits from university representatives, students and parents are guided through the post-secondary process.

GLC20 (0.5 credit) Career Studies
55 hours Grade 10, Open

This course gives students the opportunity to develop the skills, knowledge, and habits that will support them in their education and career/life planning. Students will learn about global work trends, and seek opportunities within the school and community to expand and strengthen their transferable skills and their ability to adapt to the changing world of work. On the basis of exploration, reflective practice, and decision-making processes, students will make connections between their skills, interests, and values and their postsecondary options, whether in apprenticeship training, college, community living, university, or the workplace. They will set goals and create a plan for their first postsecondary year. As part of their preparation for the future, they will learn about personal financial management – including the variety of saving and borrowing tools available to them and how to use them to their advantage – and develop a budget for their first year after secondary school.

Prerequisite: None

GLE20 Learning Strategies I: Skills for Success in Secondary School
Grade 10, Open

This course focuses on learning strategies to help students become better, more independent learners. Students will learn how to develop and apply literacy and numeracy skills, personal management skills, and interpersonal and teamwork skills to improve their learning and achievement in school, the workplace, and the community. The course helps students build confidence and motivation to pursue opportunities for success in secondary school and beyond.

Prerequisite: Recommendation of Head of Upper School

GLS10 Learning Strategies I: Skills for Success in Secondary School
Grade 9, Open

This course focuses on learning strategies to help students become better, more independent learners. Students will learn how to develop and apply literacy and numeracy skills, personal management skills, and interpersonal and teamwork skills to improve their learning and achievement in school, the workplace, and the community. The course helps students build confidence and motivation to pursue opportunities for success in secondary school and beyond.

Prerequisite: Recommendation of Head of Upper School

Health and Physical Education

Mission Statement: It is the mission of Villanova College's Physical and Health Education department to instill in our students the understanding that choice is the most essential aspect of their character development. As physical educators we will ensure that our students develop a commitment to life-long learning and a healthy active lifestyle. We will emphasize safe participation in active experiences and develop student abilities to lead and facilitate these experiences. We will develop skills in individual/team sports, fitness, and leisure activities with an emphasis on open and clear communication. Our practices as teachers and coaches will be guided by the Augustinian values of Unitas, Caritas and Veritas.

PAF30 Healthy Living and Personal and Fitness Activities Grade 11, Open

This course enables students to further develop the knowledge and skills they need to make healthy choices now and lead healthy, active lives in the future. Through participation in a wide range of physical activities and exposure to a broader range of activity settings, students enhance their movement competence, personal fitness, and confidence. Students also acquire an understanding of the factors and skills that contribute to healthy development and learn how their own well-being is affected by, and affects, the world around them. Students build their sense of self, learn to interact positively with others, and develop their ability to think critically and creatively. Specific strategies that set this course apart from PPL30 include an emphasis on personal fitness rather than large group or traditional team games.

Prerequisite: None

PPL10 Healthy Active Living Education Grade 9, Open

This course equips students with the knowledge and skills they need to make healthy choices now and lead healthy, active lives in the future. Through participation in a wide range of physical activities, students develop knowledge and skills related to movement competence and personal fitness that provide a foundation for active living. Students also acquire an understanding of the factors and skills that contribute to healthy development and learn how their own well-being is affected by, and affects, the world around them. Students build their sense of self, learn to interact positively with others, and develop their ability to think critically and creatively.

Prerequisite: None

PPL20 Healthy Active Living Education Grade 10, Open

This course enables students to further develop the knowledge and skills they need to make healthy choices now and lead healthy, active lives in the future. Through participation in a wide range of physical activities, students develop knowledge and skills related to movement competence and personal fitness that provide a foundation for active living. Students also acquire an understanding of the factors and skills that contribute to healthy development and learn how their own well-being is affected by, and affects, the world around them. Students build their sense of self, learn to interact positively with others, and develop their ability to think critically and creatively.

Prerequisite: None

PPL4O Healthy Active Living Education
Grade 12, Open

This course enables students to further develop the knowledge and skills they need to make healthy choices. It places special emphasis on how students can maintain the habits of healthy, active living throughout their lives as they make the transition to adulthood and independent living. Through participation in a wide range of physical activities in a variety of settings, students can enhance their movement competence, personal fitness, and confidence. Students also acquire an understanding of the factors and skills that contribute to healthy development and learn how their own well-being is affected by, and affects, the world around them. Students build their sense of self, learn to interact positively with others, and develop their ability to think critically and creatively.

Prerequisite: None

PSK4U Introductory Kinesiology
Grade 12, University Preparation

This course focuses on the study of human movement and of systems, factors, and principles involved in human development. Students will learn about the effects of physical activity on health and performance, the evolution of physical activity and sport, and the physiological, psychological, and social factors that influence an individual's participation in physical activity and sport. The course prepares students for university programs in physical education and health, kinesiology, health sciences, health studies, recreation, and sports administration.

Prerequisite: Any Grade 11 university or university/college preparation course in Science, or any Grade 11 or 12 course in Health and Physical education

Interdisciplinary Studies

IDC4U Sports and Entertainment Marketing
Grade 12, University Preparation

This course will help students develop and consolidate the skills required for and knowledge of different subjects and disciplines to solve problems, make decisions, create personal meaning, and present findings related to the growing Sport and Entertainment industry. Students will apply the principles and processes of inquiry and research to effectively use a range of print, electronic, and mass media resources; to analyze historical innovations and exemplary research; and to investigate real-life situations and career opportunities in this industry. Students will acquire knowledge in the areas of ethics, consumer behaviour, consumer research, product development, pricing strategies, advertising, public relations, event marketing, promotional licensing, sponsorship, product distribution, stadium design, legal issues and career opportunities in Sports and Entertainment Marketing.

Prerequisite: Any Grade 11 university or university/college preparation course in Business Studies, Canadian and World Studies, English or Social Sciences and the Humanities.

Mathematics

Mission Statement: The Mathematics, Business, Design, Computer Science and Communications Technology Department is dedicated to preparing students for a rapidly changing world by expanding each student's knowledge and skills. It is our goal to have our students understand and appreciate the concepts they are studying; that they can read, write, explore, and communicate these concepts with confidence; and that they value the ability to use them, as needed, in their lives. It is our belief that the knowledge, skills and ethics taught are necessary for active, life-long participation in a global society—fostering success in one's personal life, post-secondary study, and career choice.

MCF3M Functions and Applications Grade 11, University/College Preparation

This course introduces basic features of the function by extending students' experiences with quadratic relations. It focuses on quadratic, trigonometric, and exponential functions and their use in modelling real-world situations. Students will represent functions numerically, graphically, and algebraically; simplify expressions; solve equations; and solve problems relating to applications. Students will reason mathematically and communicate their thinking as they solve multi-step problems.

Prerequisite: Principles of Mathematics, Grade 10, Academic, or Foundations of Mathematics, Grade 10, Applied

MCR3U Functions Grade 11, University Preparation

This course introduces the mathematical concept of the function by extending students' experiences with linear and quadratic equations. Students will investigate properties of discrete and continuous functions, including trigonometric and exponential functions; represent functions numerically, algebraically, and graphically; solve problems involving applications of functions; investigate inverse functions; and develop facility in determining equivalent algebraic expressions. Students will reason mathematically and communicate their thinking as they solve multi-step problems.

Prerequisite: Principles of Mathematics, Grade 10, Academic

MCV4U Calculus and Vectors Grade 12, University Preparation

This course builds on students' experience with functions and their developing understanding of rates of change. Students will solve problems involving geometric and algebraic representations of vectors, and representations of lines and planes in three-dimensional space; broaden their understanding of rates of change to include the derivatives of polynomial, sinusoidal, exponential, rational and radical functions; and apply these concepts and skills to the modeling of real-world relationships. Students will also refine their use of the mathematical processes necessary for success in senior mathematics. This course is intended for students who choose to pursue careers in fields such as science, engineering, economics, and some areas of business including those students who will be required to take a university-level calculus, linear algebra, or physics course.

Prerequisite/Co-requisite: Advanced Functions, Grade 12, University Preparation

MDM4U Mathematics of Data Management
Grade 12, University Preparation

This course broadens students' understanding of mathematics as it relates to managing data. Students will apply methods for organizing large amounts of information; solve problems involving probability and statistics; and carry out a culminating investigation that integrates statistical concepts and skills. Students will also refine their use of the mathematical processes necessary for success in senior mathematics. Students planning to enter university programs in business, the social sciences, and the humanities will find this course of particular interest.

Prerequisite: Functions, Grade 11, University Preparation, or Functions and Applications, Grade 11, University/College Preparation

MHF4U Advanced Functions
Grade 12, University Preparation

This course extends students' experience with functions. Students will investigate the properties of polynomial, rational, logarithmic, and trigonometric functions; develop techniques for combining functions; broaden their understanding of rates of change; and develop facility in applying these concepts and skills. Student will also refine their use of the mathematical processes necessary for success in senior mathematics. This course is intended both for students taking the Calculus and Vectors course as a prerequisite for a university program and for those wishing to consolidate their understanding of mathematics before proceeding to any one of a variety of university programs.

Prerequisite: Functions, Grade 11, University Preparation, or Mathematics for College Technology, Grade 12, College Preparation

MTH1W Principles of Mathematics
Grade 9, Academic

This course enables students to develop an understanding of mathematical concepts related to algebra, analytic geometry, and measurement and geometry through investigation, the effective use of technology, and abstract reasoning. Students will investigate relationships, which they will then generalize as equations of lines, and will determine the connections between different representations of a linear relation. They will also explore relationships that emerge from the measurement of three-dimensional figures and two-dimensional shapes. Students will reason mathematically and communicate their thinking as they solve multi-step problems.

Prerequisite: None

MPM2D Principles of Mathematics
Grade 10, Academic

This course enables students to broaden their understanding of relationships and extend their problem-solving and algebraic skills through investigation, the effective use of technology, and abstract reasoning. Students will explore quadratic relations and their applications; solve and apply linear systems; verify properties of geometric figures using analytic geometry; and investigate the trigonometry of right and acute triangles. Students will reason mathematically and communicate their thinking as they solve multi-step problems.

Prerequisite: Mathematics, Grade 9, Destreamed

Religious Education

Mission Statement: Religious instruction is a scholastic discipline with the same systematic demands and rigour as other courses. Far from an accessory, religious instruction presents the Christian message and the Christian event in an engaging and inter-disciplinary manner. The presentation of the Christian message influences the way in which the origins of the world, the sense of history, the basis of ethical values, the function of religion in culture, the destiny of [humankind] and [their] relationship with nature, are understood. Through inter-disciplinary dialogue religious instruction underpins, activates, develops, and completes the educational activity of the school.

HRE13 Religious Education – Be with Me Grade 9, Open

This course invites students to a deeper understanding of the covenantal relationship between God and the Jewish people and to Biblical records and passages which are a primary source of God’s revelation. Students will explore a variety of topics related to the themes of personhood, interpersonal relationships, and sexuality. They are encouraged to understand and nurture within themselves the virtues which will enable them to deepen their relationship with God in and through Christ in the context of a Spirit-filled community.

Prerequisite: None

HRE23 Religious Education – Christ and Culture Grade 10, Open

This course examines the relationship between the person and message of Christ and the dominant attitudes of contemporary culture. Central to this course is the sacramental nature of Jesus and through His incarnation, the sacramentality of the Catholic Church, persons, and all of creation. Beginning with students’ own life experience in the light of the Gospel narratives, students acquire a deeper and more systematic knowledge of Christ, his message, and his Church.

Prerequisite: None

HRE4M Church and Culture Grade 12, University/College Preparation

This course is directed and designed to expose the maturing student to the rich tradition of the Catholic Christian Story. To identify what it is to be Catholic, to explore Catholic Morality and Ethics, to discover Catholic Social Teaching and Catholic doctrines and teachings and to rediscover Jesus, the Gospels and their application to the Grade 12 student’s life. Much attention will be given to the interaction between Church and Culture. The modern world is often characterized by a multiplicity of values, philosophies and ideologies. In a democratic and pluralistic society, these concepts may creatively reinforce one another, or they may compete with and contradict one another. To be a Catholic often means to stand opposed to the values and norms of society and it is a challenge to live in the society and yet not “of” society. “Church and Culture” will explore these shifting dynamics while preparing the student for graduation and a lifelong journey with the Church, with others and the world, with themselves and ultimately with God.

Course Requirement: KAIROS retreat

Prerequisite: None

HRE4M1

Leaders in Church and Culture

Grade 12, University/College Preparation

For course description refer to HRE4M. This course places an emphasis on experiential leadership in a Catholic context and encourages students to explore their role as a leader within the Church and the greater community. All applicants to this course must participate in a three-day training retreat in September and a week-long mission trip to work with Habitat for Humanity and Catholic Social Services. Through various texts, experiences and guest speakers, we hope to expose students in a new way, to the Catholic Church.

Course Requirements: KAIROS retreat, Habitat for Humanity excursion

Prerequisite: None

Science

Mission Statement: The Villanova Science department is committed to providing opportunities for students to develop their understanding of scientific concepts through inquiry and investigation with the pursuit of meaningful work related to science. This includes fostering an environment for the student to be innovative and creative while developing rational and critical thought, accuracy, precision, integrity in observation; respect for evidence; adherence to safety procedures; and cultivating, via faith and spirituality founded in Catholic roots, respect for all living things and our environment.

SBI3U Biology Grade 11, University Preparation

This course furthers students' understanding of the processes involved in biological systems. Students will study cellular functions, genetic continuity, internal systems and regulation, the diversity of living things, and the anatomy, growth, and functions of plants. The course focuses on the theoretical aspects of the topics under study, and helps students refine skills related to scientific investigation.

Prerequisite: Science, Grade 10, Academic

SBI4U Biology Grade 12, University Preparation

This course provides students with the opportunity for in-depth study of the concepts and processes associated with biological systems. Students will study theory and conduct investigations in the areas of metabolic processes, molecular genetics, homeostasis, evolution, and population dynamics. Emphasis will be placed on achievement of the detailed knowledge and refined skills needed for further study in various branches of the life sciences and related fields.

Prerequisite: Biology, Grade 11, University Preparation

SCH3U Chemistry Grade 11, University Preparation

This course enables students to deepen their understanding of chemistry through the study of the properties of chemicals and chemical bonds; chemical reactions and quantitative relationships in those reactions; solutions and solubility; and atmospheric chemistry and the behaviour of gases. Students will further develop their analytical skills and investigate the qualitative and quantitative properties of matter, as well as the impact of some common chemical reactions on society and the environment.

Prerequisite: Science, Grade 10, Academic

SCH4U Chemistry Grade 12, University Preparation

This course enables students to deepen their understanding of chemistry through the study of organic chemistry, energy changes and rates of reaction, chemical systems and equilibrium, electrochemistry, and atomic and molecular structure. Students will further develop problem-solving and laboratory skills as they investigate chemical processes, at the same time refining their ability to communicate scientific information. Emphasis will be placed on the importance of chemistry in daily life, and on evaluating the impact of chemical technology on the environment.

Prerequisite: Chemistry, Grade 11, University Preparation

SNC1W Science
 Grade 9, Academic

This course enables students to develop their understanding of basic concepts in biology, chemistry, earth and space science, and physics, and to relate science knowledge to technology, society, and the environment. Throughout the course, students will develop their skills in the processes of scientific investigation. Students will acquire an understanding of scientific theories and conduct investigations related to sustainable ecosystems, atomic and molecular structures, and the properties of elements and compounds, the study of the universe and its properties and components; and the principles of electricity.

Prerequisite: None

SNC2D Science
 Grade 10, Academic

This course enables students to enhance their understanding of concepts in biology, chemistry, earth and space science, and physics, and of the interrelationships between science, technology, society, and the environment. Students are also given opportunities to further develop their scientific investigation skills. Students will plan and conduct investigations and develop their understanding of scientific theories related to the connections between cells and systems in animals and plants; chemical reactions, with a particular focus on acid-base reactions; factors that affect climate and climate change; and the interaction of light and matter.

Prerequisite: Science, Grade 9, Academic or Applied

SPH3U Physics
 Grade 11, University Preparation

This course develops students' understanding of the basic concepts of physics. Students will explore kinematics, with an emphasis on linear motion; different kinds of forces; energy transformations; the properties of mechanical waves and sound; and electricity and magnetism. They will enhance their scientific investigation skills as they test laws of physics. In addition, they will analyze the interrelationships between physics and technology, and consider the impact of technological applications of physics on society and the environment.

Prerequisite: Science, Grade 10, Academic

SPH4U Physics
 Grade 12, University Preparation

This course enables students to deepen their understanding of physics concepts and theories. Students will continue their exploration of energy transformations and the forces that affect motion, and will investigate electrical, gravitational, and magnetic fields and electromagnetic radiation. Students will also explore the wave nature of light, quantum mechanics, and special relativity. They will further develop their scientific investigation skills, learning, for example, how to analyze, qualitatively and quantitatively, data related to a variety of physics concepts and principles. Students will also consider the impact of technological applications of physics on society and the environment.

Prerequisite: Physics, Grade 11, University Preparation

Social Sciences and Humanities

Mission Statement: In Humanities and Social Sciences we engage students in the Augustinian spirit of integrating faith, reason, and culture. Our courses study how families, communities, cultures, institutions, and societies are influenced by ideas, norms, and values. This study proceeds from a Catholic understanding of the human person, the person's social relationships and the moral laws that govern them. The goal of these studies is to bring a critical and self-reflective understanding to bear in order to promote justice and transform local and global communities. We seek to guide our students through the restlessness of their individual journeys as they search for the essential truth.

HRT3M World Religions and Belief Traditions: Perspectives, Issues, and Challenges Grade 11, University/College Preparation

This course provides students with opportunities to explore various world religions and belief traditions. Students will develop knowledge of the terms and concepts relevant to this area of study, will examine the ways in which religions and belief traditions meet various human needs, and will learn about the relationship between belief and action. They will examine sacred writings and teachings, consider how concepts of time and place influence different religions and belief traditions, and develop research and inquiry skills related to the study of human expressions of belief.

Prerequisite: None

HSP3U Introduction to Anthropology, Psychology, and Sociology Grade 11, University Preparation

This course provides students with opportunities to think critically about theories, questions, and issues related to anthropology, psychology, and sociology. Students will develop an understanding of the approaches and research methods used by social scientists. They will be given opportunities to explore theories from a variety of perspectives, to conduct social science research, and to become familiar with current thinking on a range of issues within the three disciplines.

Prerequisite: English, Grade 10, Academic, or Canadian History Since WW1, Grade 10, Academic

HZT4U Philosophy: Questions and Theories Grade 12, University Preparation

This course enables students to acquire an understanding of the nature of philosophy and philosophical reasoning skills and to develop and apply their knowledge and skills while exploring specialized branches of philosophy (the course will cover at least three of the following branches: metaphysics, ethics, epistemology, philosophy of science, social and political philosophy, esthetics). Students will develop critical thinking and philosophical reasoning skills as they formulate and evaluate arguments related to a variety of philosophical questions and theories. They will also develop research and inquiry skills related to the study and practice of philosophy.

Prerequisite: Any university or university/college preparation course in Social Sciences and Humanities, English, or Canadian and World Studies

Technological Education

Mission Statement: The Mathematics, Business, Design, Computer Science and Communications Technology department is dedicated to preparing students for a rapidly changing world by expanding each student’s knowledge and skills. It is our goal to have our students understand and appreciate the concepts they are studying; that they can read, write, explore, and communicate these concepts with confidence; and that they value the ability to use them, as needed, in their lives. It is our belief that the knowledge, skills and ethics taught are necessary for active, life-long participation in a global society—fostering success in one’s personal life, post-secondary study, and career choice

TAS2O Technology and the Skilled Trades Grade 10, Open

This hands-on course enables students to apply the engineering design process, and other technological knowledge and skills introduced in earlier grades. Students will design and safely create prototypes, products, and/or services, working with tools and resources from various industries. As students develop their projects to address real-life problems, they will apply technological concepts such as quality control, and health and safety standards. Students explore opportunities for job skills programs and education and training pathways, including skilled trades, that can lead to a variety of careers.

Prerequisite: None

TDJ3M Technological Design Grade 11, University/College Preparation

This course examines how technological design is influenced by human, environmental, financial, and material requirements and resources. Students will research, design, build, and assess solutions that meet specific human needs, using working drawings and other communication methods to present their design ideas. They will develop an awareness of environmental, societal, and cultural issues related to technological design, and will explore career opportunities in the field, as well as the college and/or university program requirements for them.

Prerequisite: None

Course Fee: \$60.00

TDJ4M Technological Design Grade 12, University/College Preparation

This course introduces students to the fundamentals of design advocacy and marketing, while building on their design skills and their knowledge of professional design practices. Students will apply a systematic design process to research, design, build, and assess solutions that meet specific human needs, using illustrations, presentation drawings, and other communication methods to present their designs. Students will enhance their problem-solving and communication skills and will explore career opportunities and the postsecondary education and training requirements for them.

Prerequisite: Technological Design, Grade 11, University/College

Course Fee: \$60.00

PREREQUISITE CHARTS

The Arts (2010), Grades 9-12

These charts map out all the courses in the discipline and show the links between courses and the possible prerequisites for them. They do not attempt to depict all possible movements from course to course.

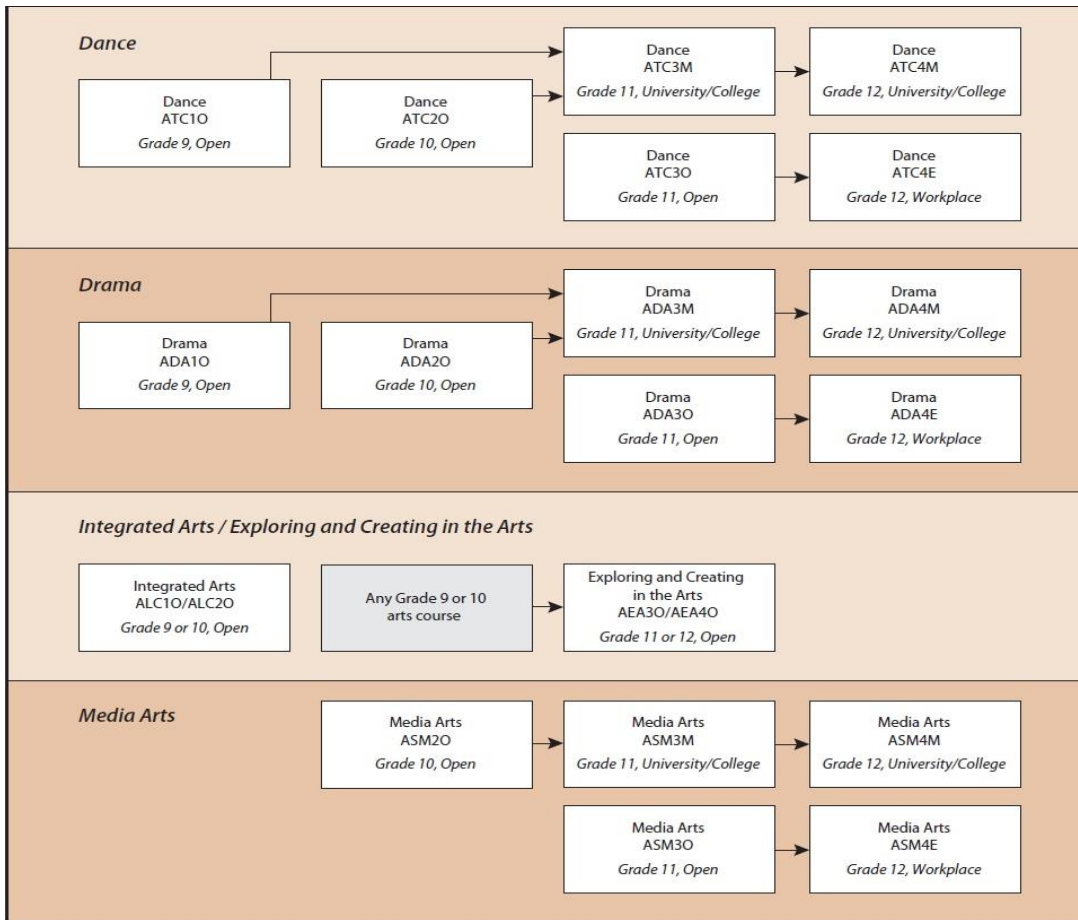

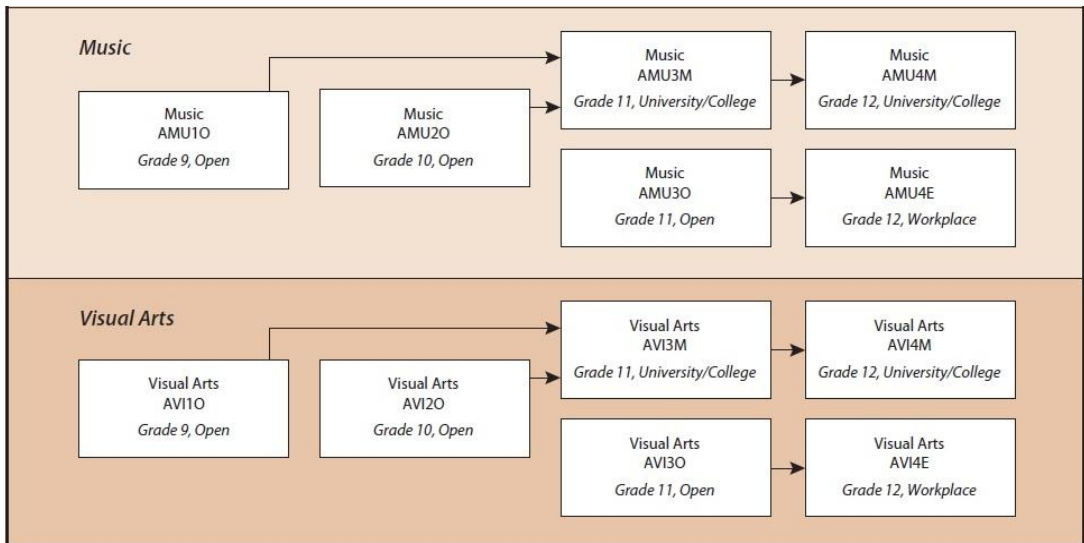

Business Studies Grades 9-10 (2024), Grades 11-12 (2006)

This chart maps out all the courses in the discipline and shows the links between courses and the possible prerequisites for them. It does not attempt to depict all possible movements from course to course.

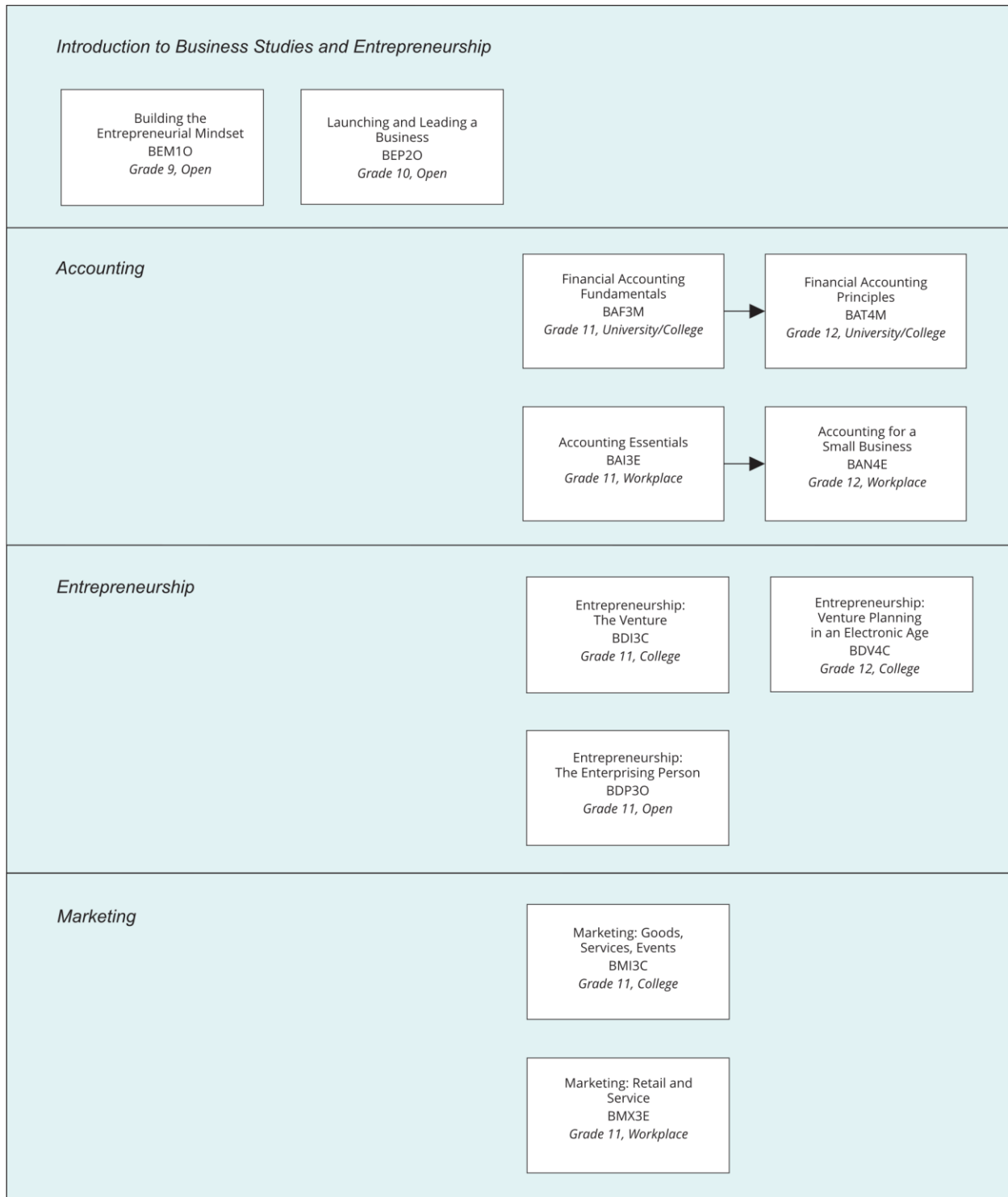

International Business

International Business
Fundamentals
BBB4M
Grade 12, University/College

International Business
Essentials
BBB4E
Grade 12, Workplace

Business Leadership

Business Leadership:
Management Fundamentals
BOH4M
Grade 12, University/College

Business Leadership:
Becoming a Manager
BOG4E
Grade 12, Workplace

Information and Communication Technology

Information and
Communication
Technology: The Digital
Environment
BTA3O
Grade 11, Open

Information and
Communication
Technology: Multimedia
Solutions
BTX4C
Grade 12, College

Information and
Communication
Technology in the Workplace
BTX4E
Grade 12, Workplace



Canadian and World Studies, Grade 9 (2024), Grade 10 (2018) and Grades 11 and 12 – Geography (2015)

This chart maps out all the courses in the discipline and shows the links between courses and the possible prerequisites for them. It does not attempt to depict all possible movements from course to course.

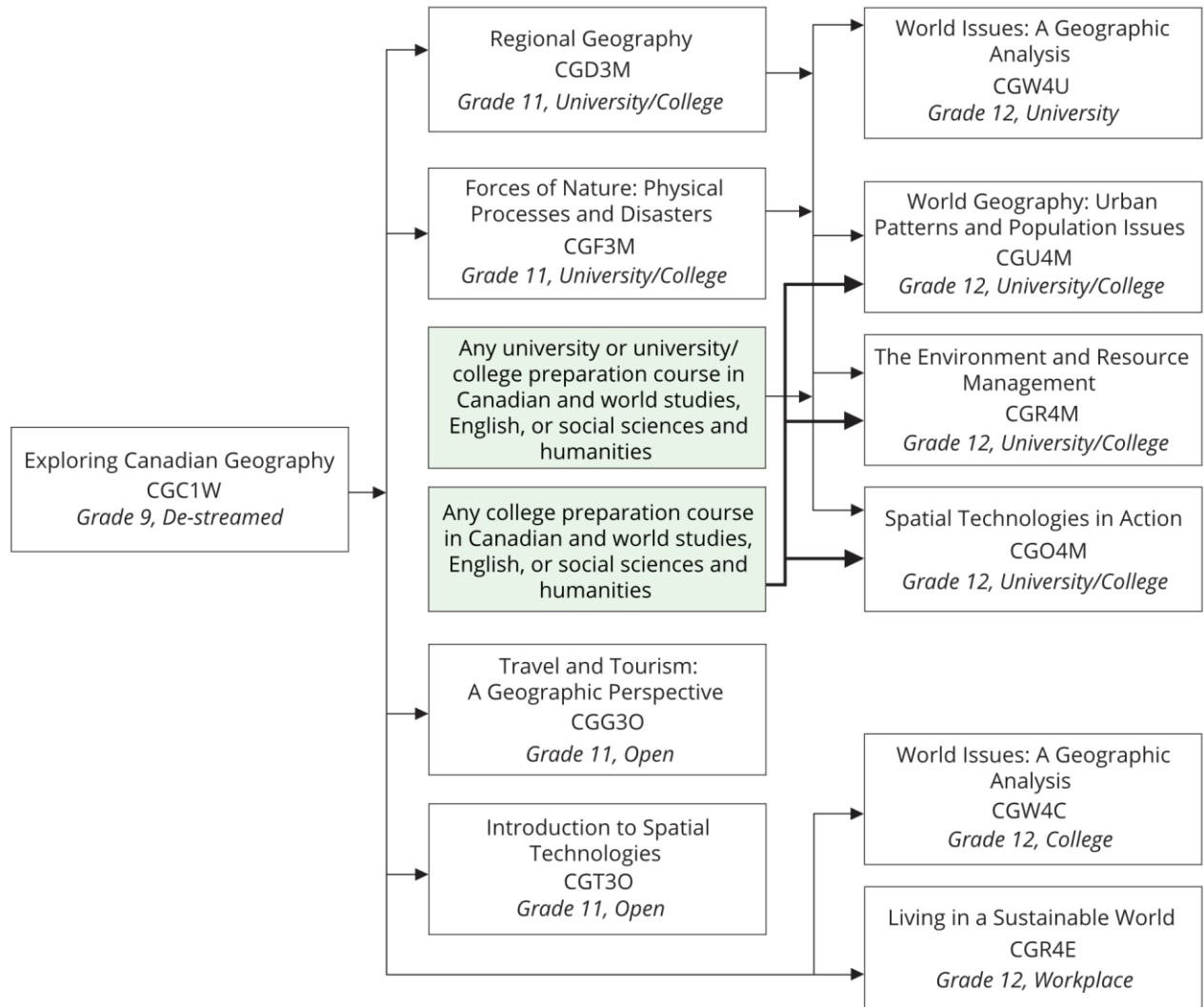

Canadian and World Studies, Grades 9 and 10 (2024) and Grades 11 and 12 – History

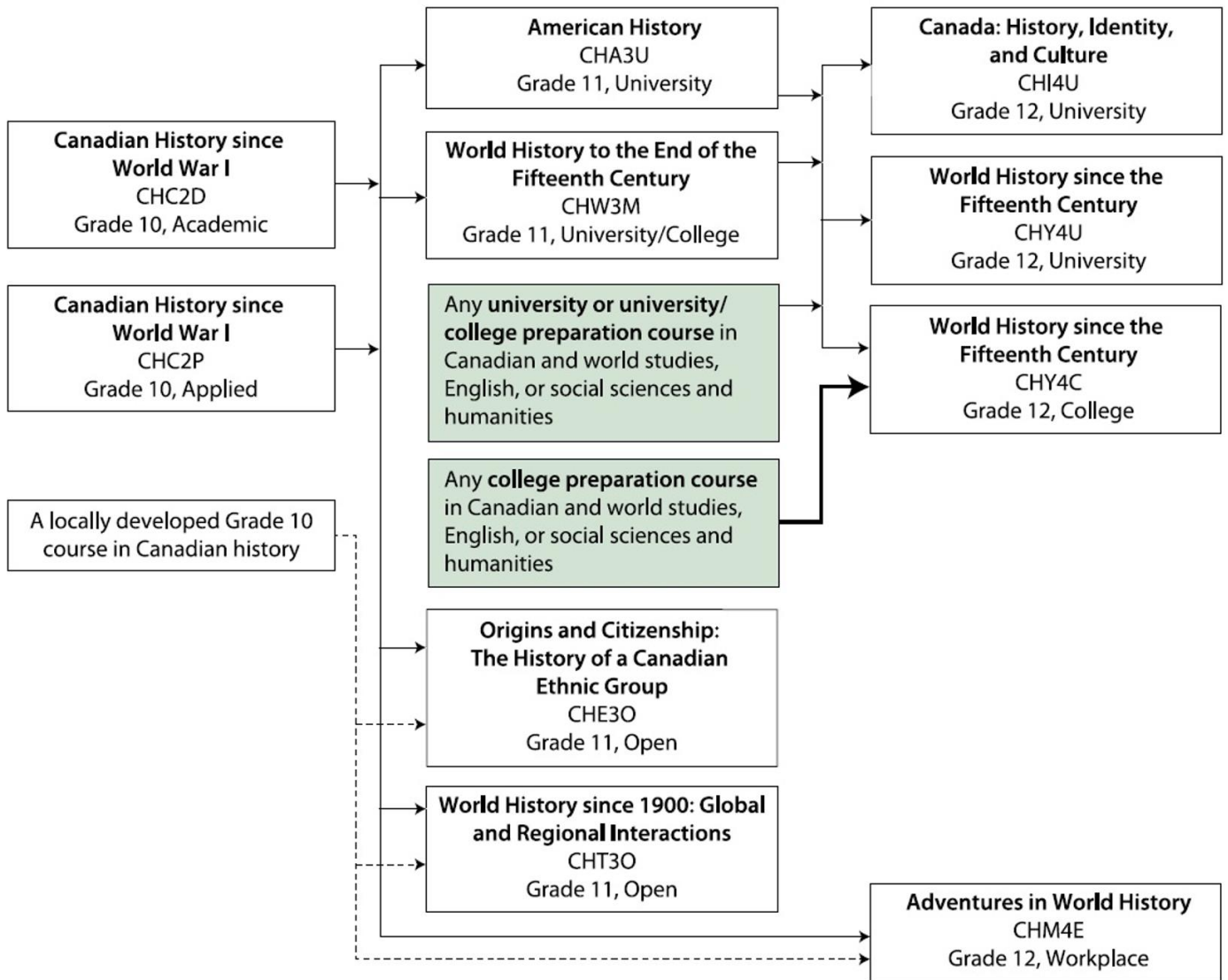

Canadian and World Studies, Grades 9 and 10 (2024) and Grades 11 and 12 – Economics, Law, and Politics

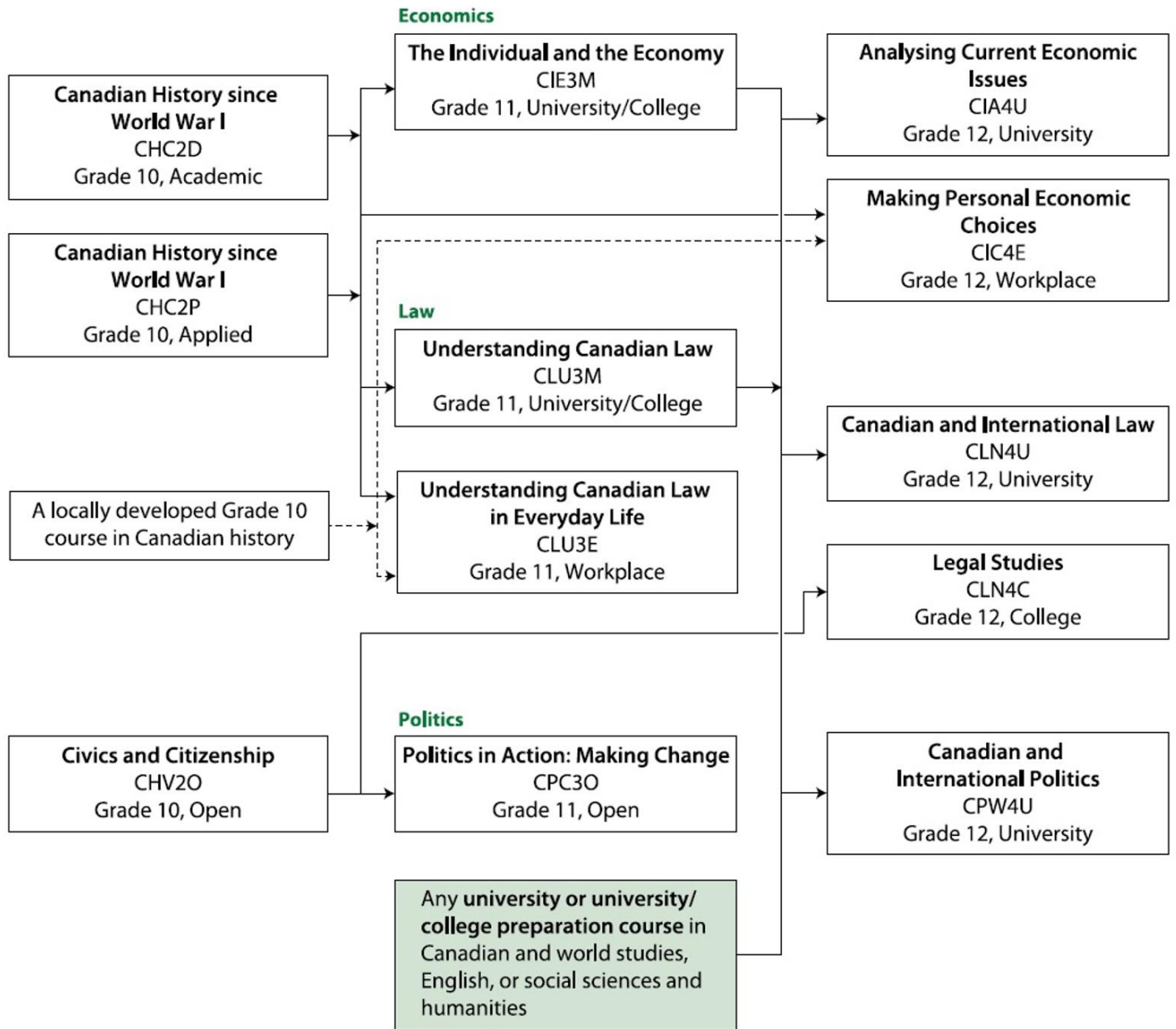

Classical Studies and International Languages (2016), Grades 9-12

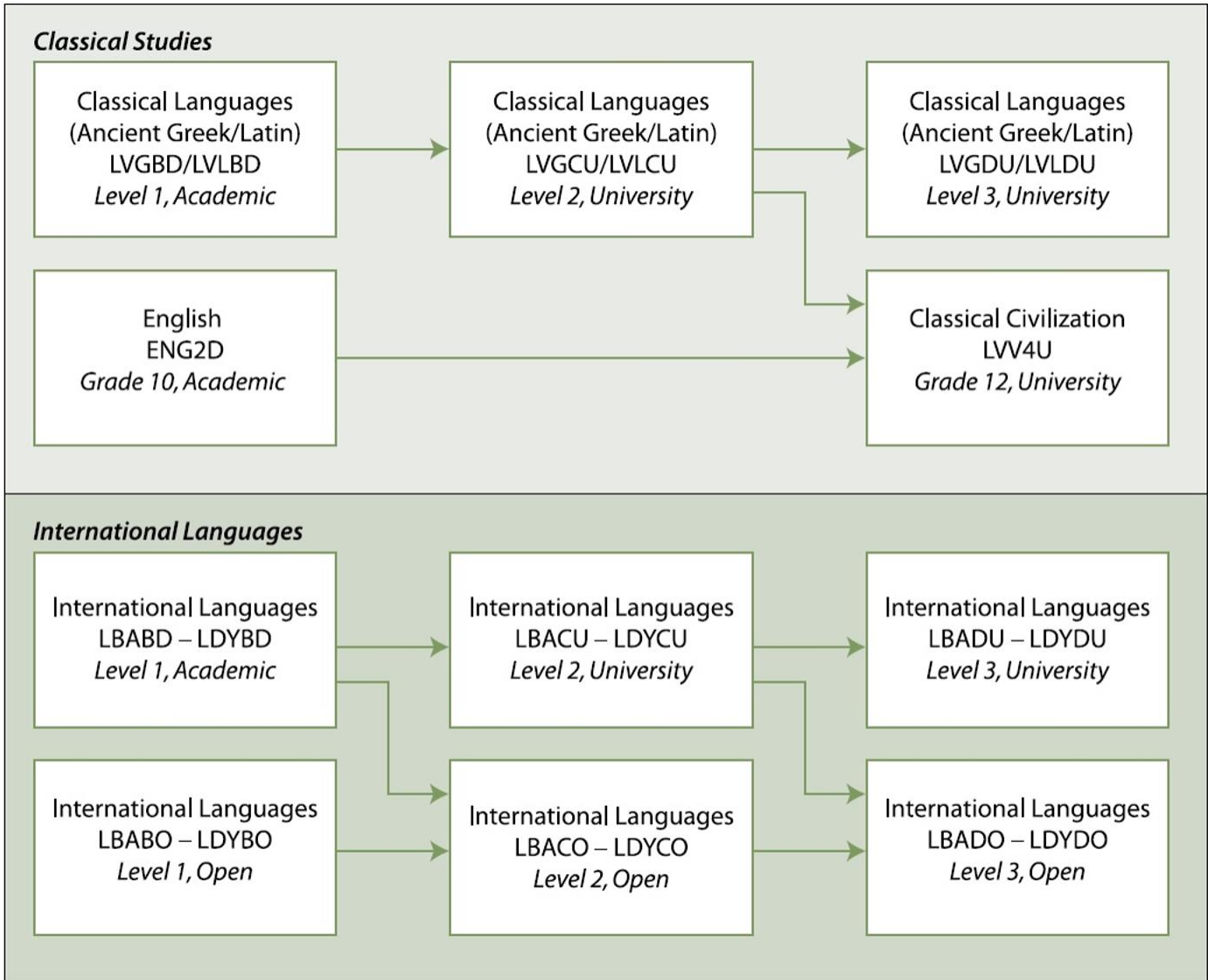

Computer Studies Grade 10 (2023), Grades 11-12 (2008)

This chart maps out all the courses in the discipline and shows the links between courses and the possible prerequisites for them. It does not attempt to depict all possible movements from course to course.

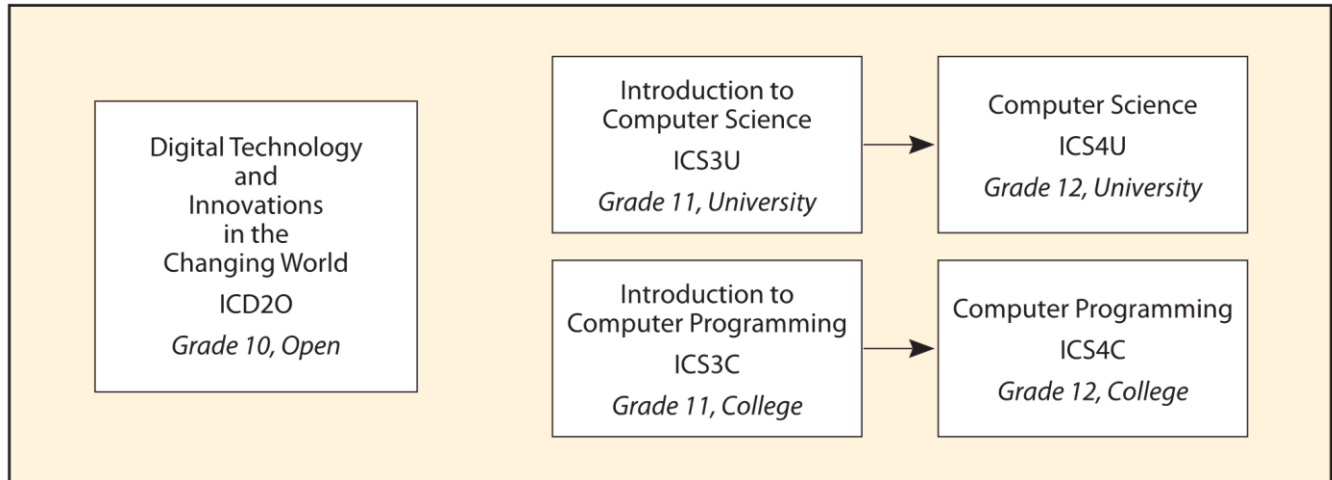

English Grade 9 (2023), Grades 10-12 (2007)

This chart maps out all the courses in the discipline and shows the links between courses and the possible prerequisites for them. It does not attempt to depict all possible movements from course to course.

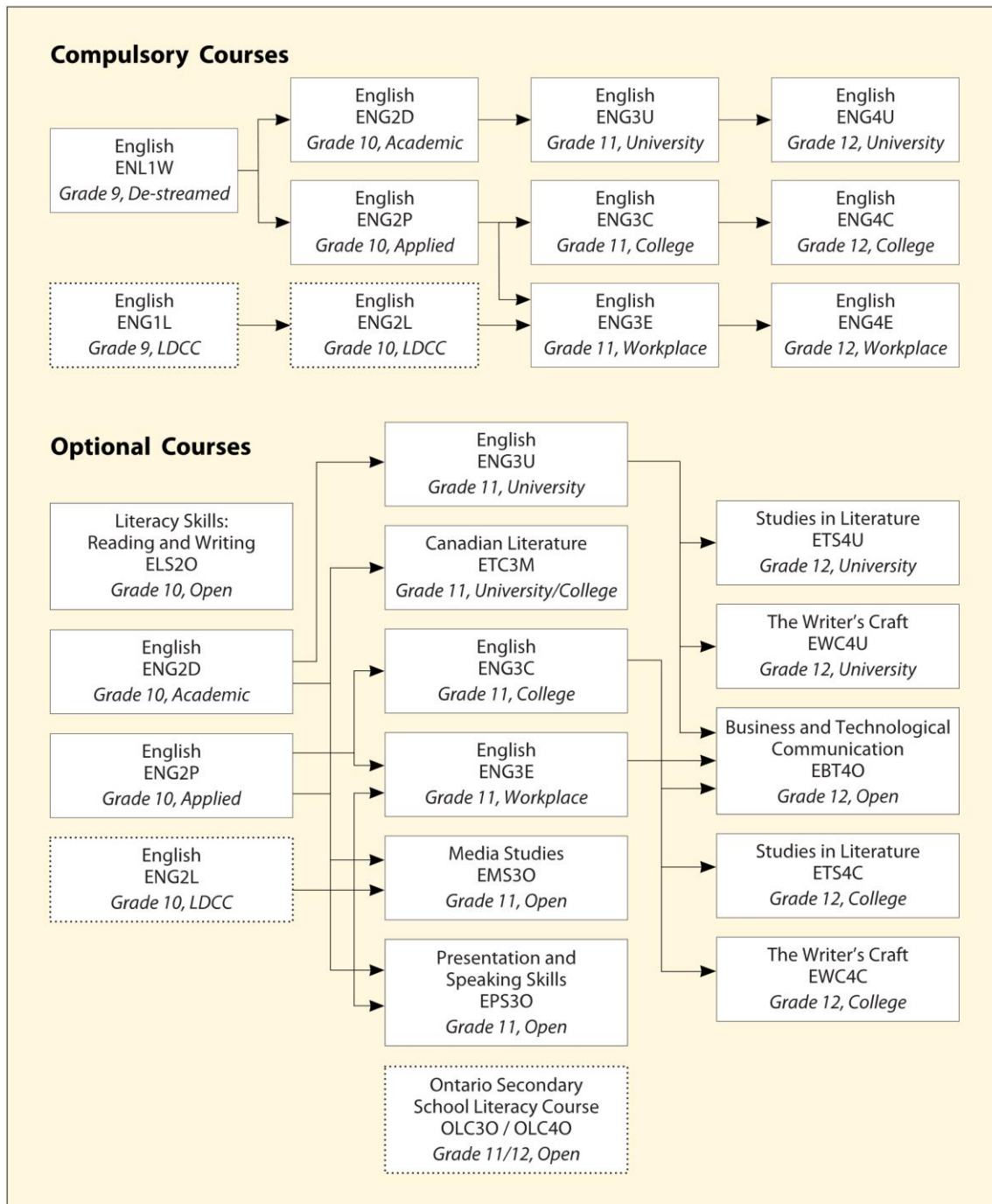

Note: Dotted lines represent compulsory courses. Dashed lines represent courses that are not outlined in the curriculum document.

English as a Second Language and English Literacy Development (2007)

The chart below shows how most English language learners may progress through their ESL and/or ELD courses and into mainstream English courses. Not all students will follow this sequence exactly, and individual students may vary in the rate at which they progress through the levels.

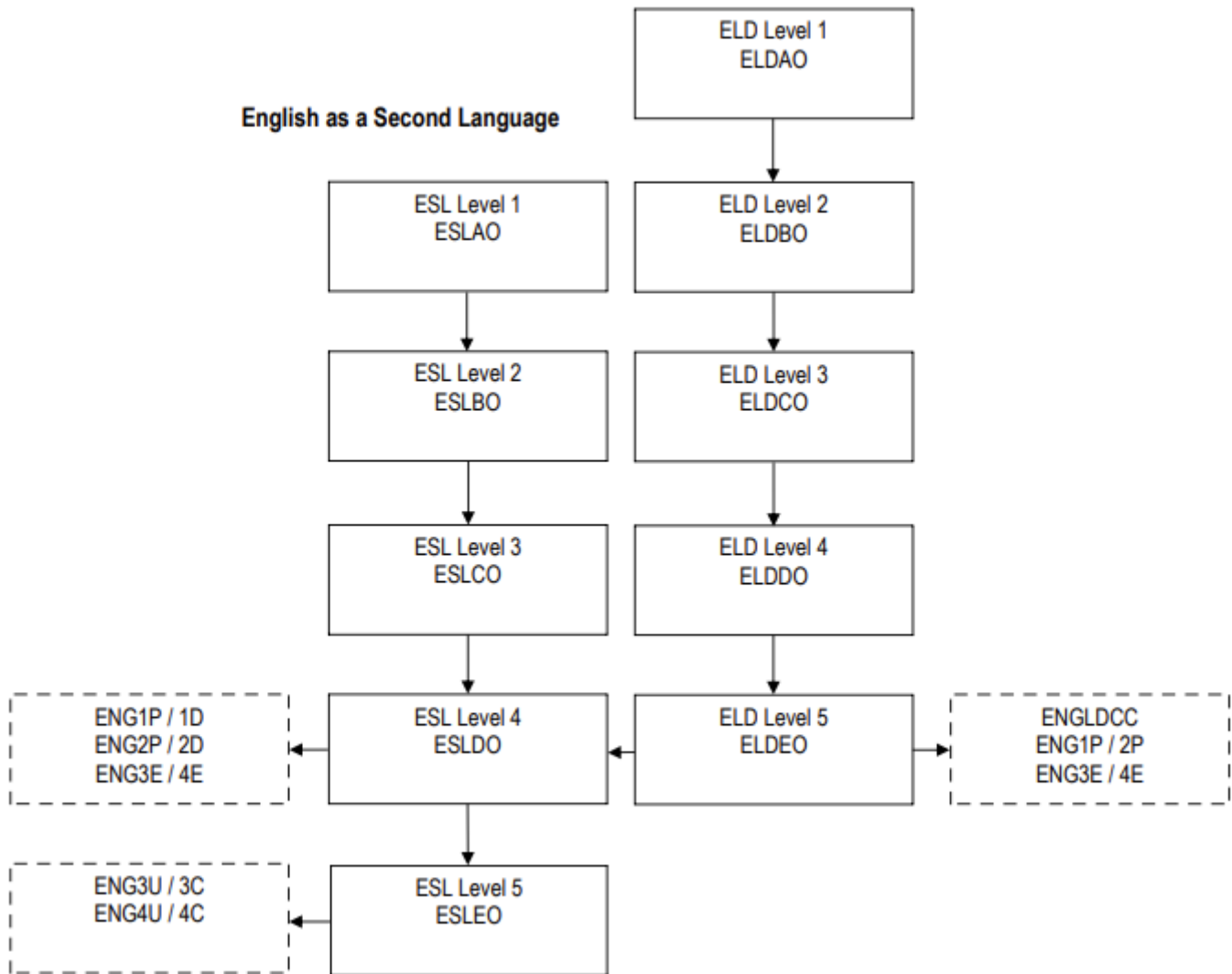

French as a Second Language (2014), Grades 9-12

This chart maps out all the courses in the discipline and shows the links between courses and the possible prerequisites for them.

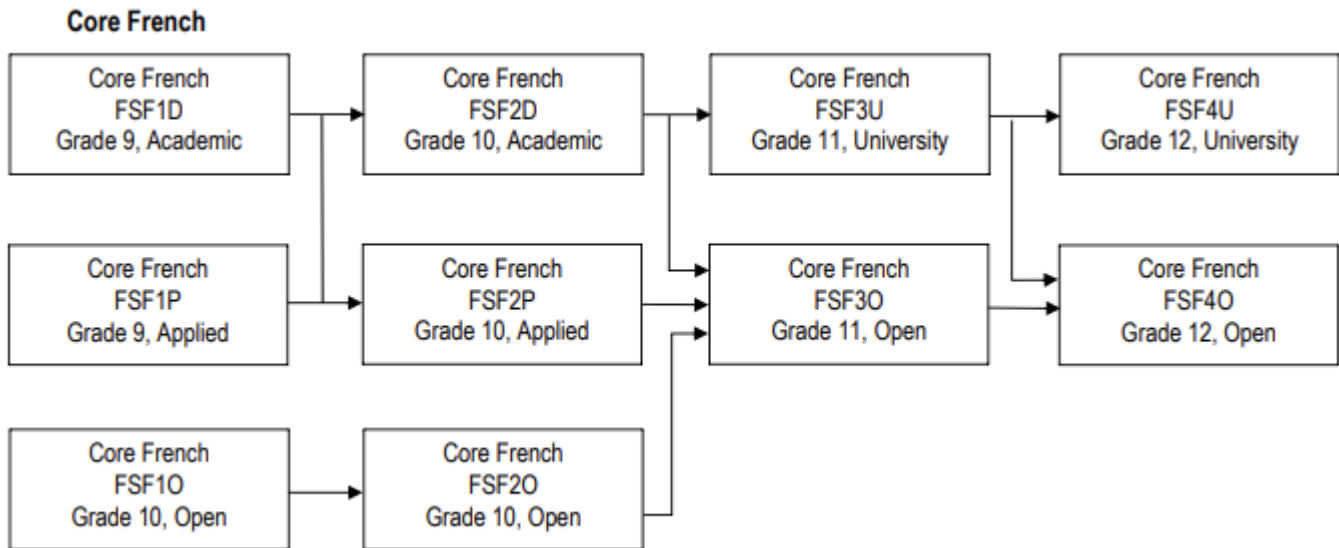

Notes:

- The prerequisite for Grade 9 French is the elementary Extended French program or the elementary French Immersion program, or equivalent.
- The prerequisite for Grade 9 French Immersion is the elementary French Immersion program, or equivalent.
- Students who have successfully completed elementary Extended French or French Immersion programs and do not wish to pursue further studies in these programs should be considered for advanced placement in the Core French program, if they demonstrate the necessary knowledge and skills.

Guidance and Career Education Grade 10 (2024), Grades 9, 11-12 (2006)

These charts map out all the courses in the discipline and shows the links between courses and the possible prerequisites for them. They do not attempt to depict all possible movements from course to course.

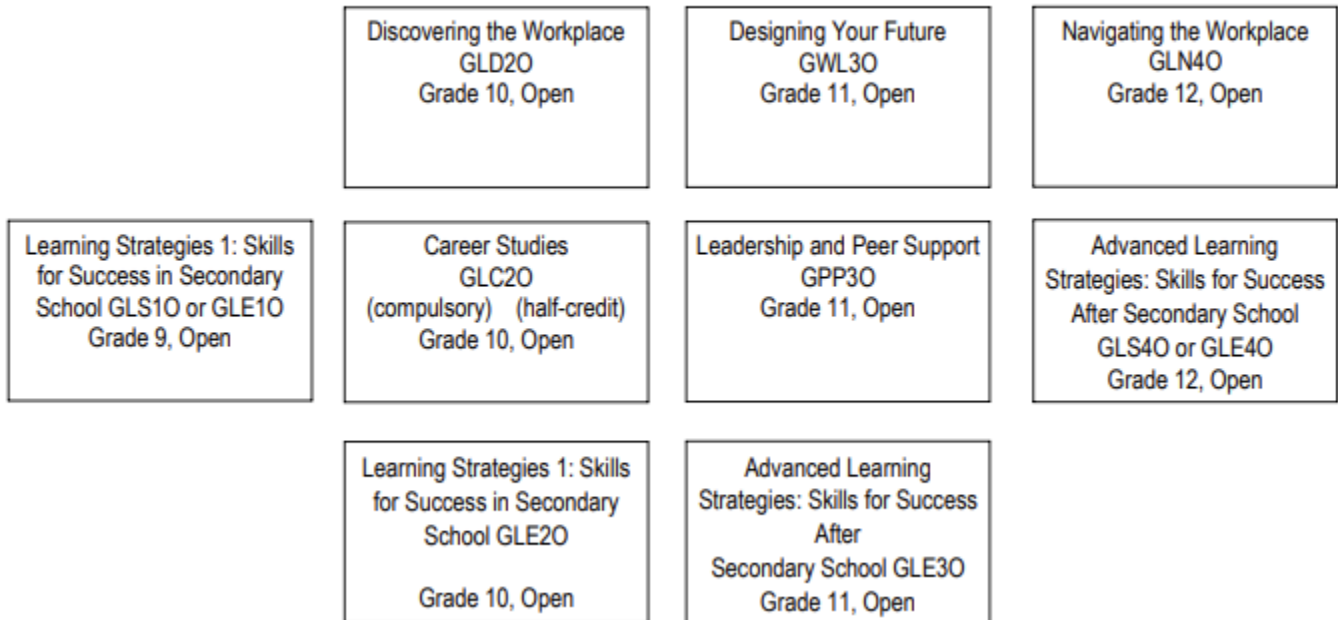

Health and Physical Education (2015), Grades 9-12

This chart maps out the courses in the discipline and shows the links between courses and the possible prerequisites for them.

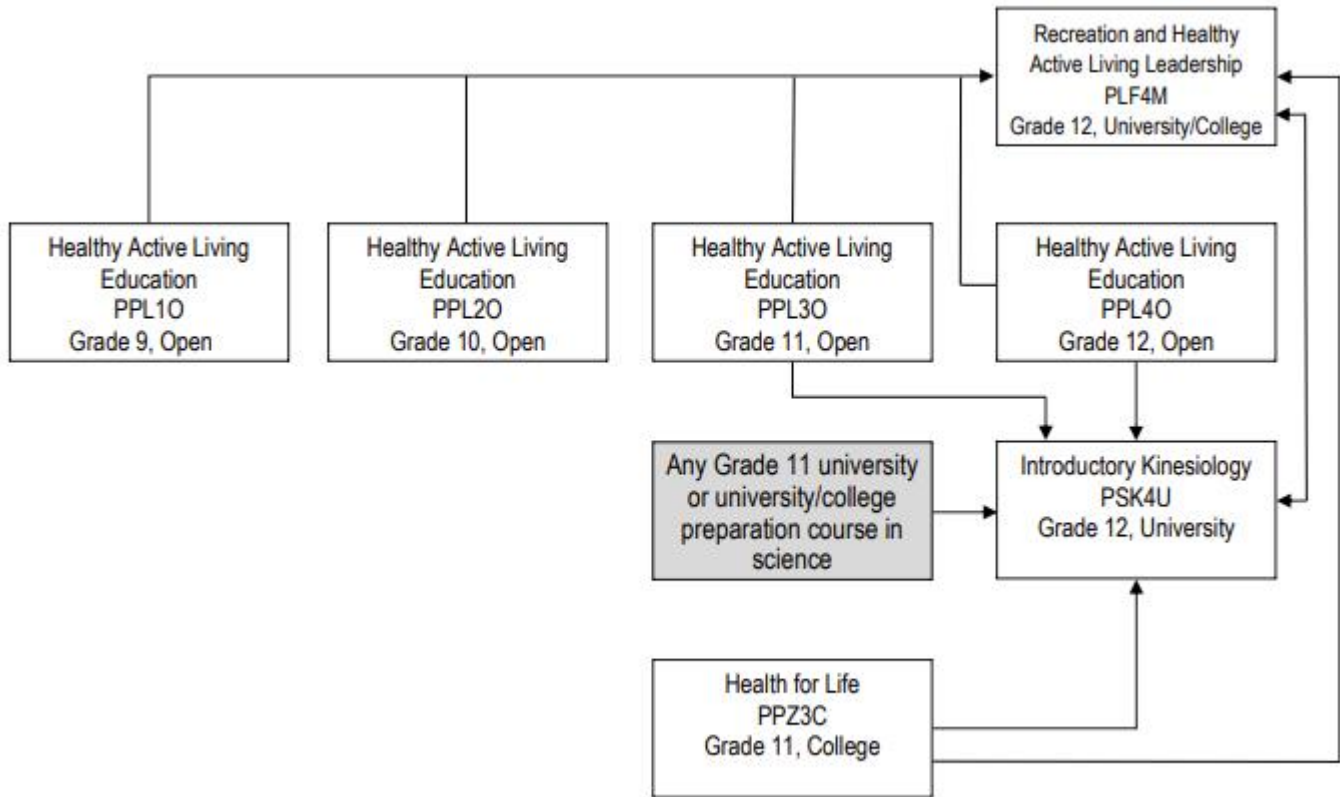

Mathematics Grade 9 (2021), Grade 10 (2005), Grades 11-12 (2007)

This chart maps out all the courses in the discipline and shows the links between courses and the possible prerequisites for them. It does not attempt to depict all possible movements from course to course.

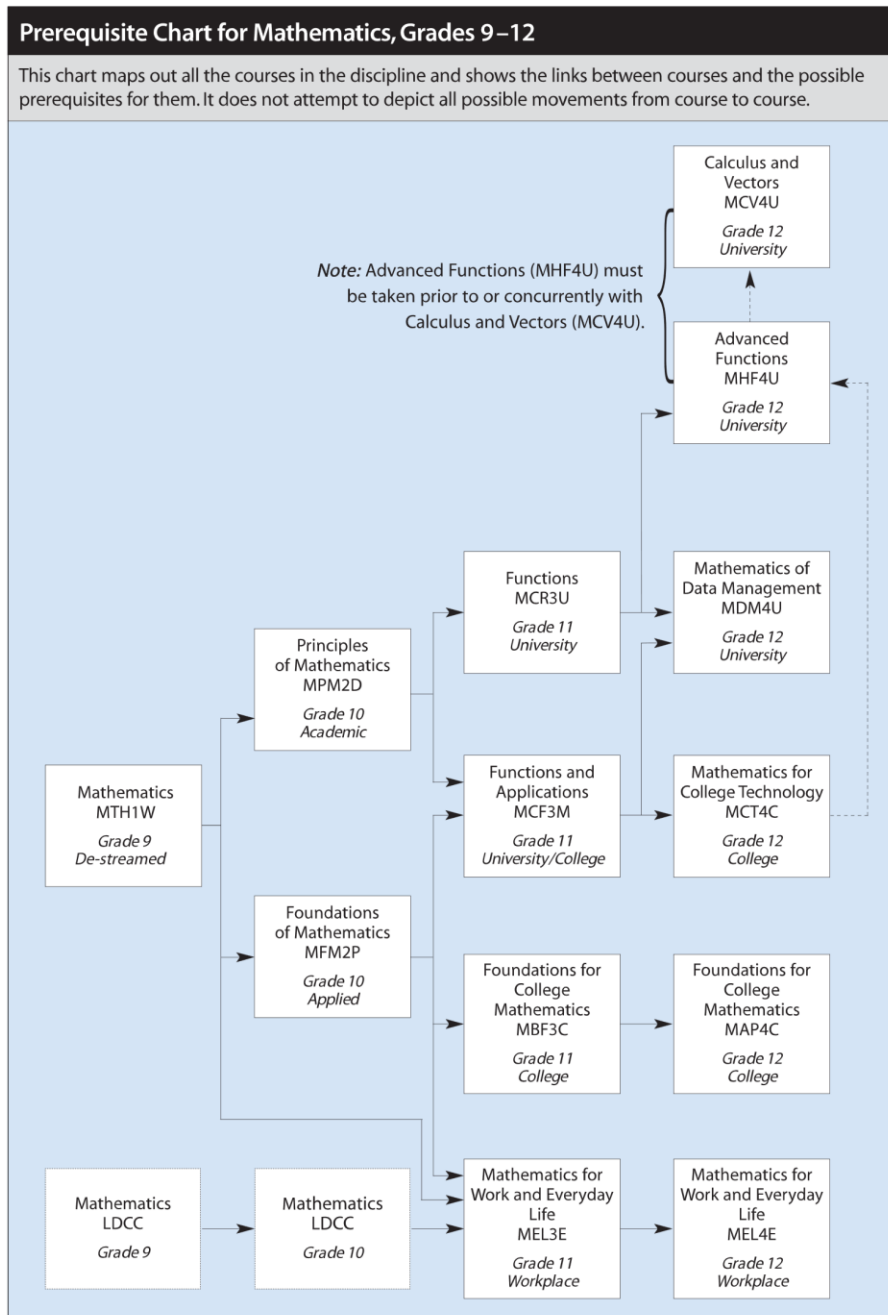

Note: LDCC – locally developed compulsory credit course (LDCC courses are not outlined in this curriculum.)

Science Grade 9 (2022), Grades 10-12 (2008)

This chart maps out all the courses in the discipline and shows the links between courses and the possible prerequisites for them. It does not attempt to depict all possible movements from course to course.

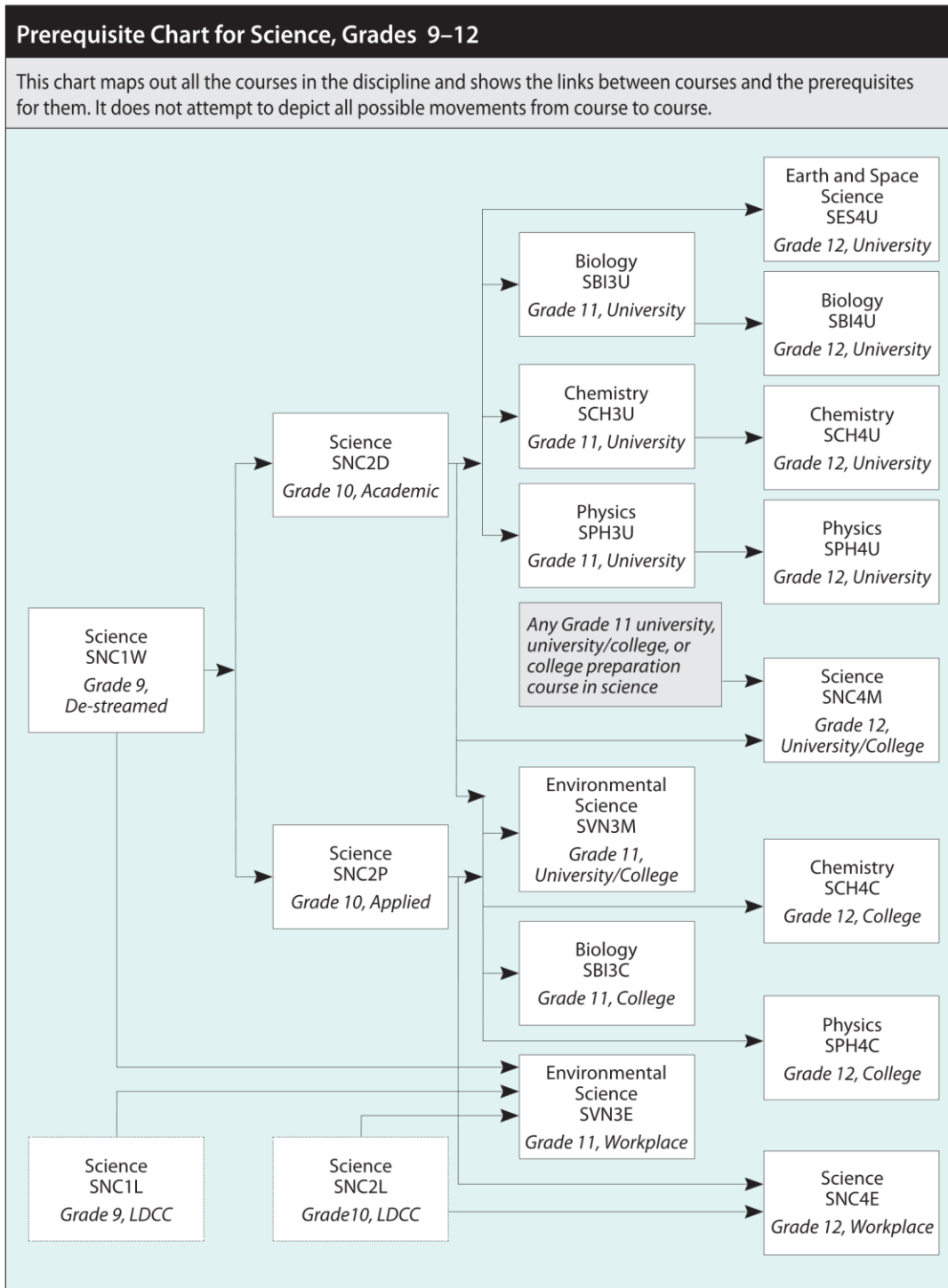

Social Sciences and Humanities (2013), Grades 9-12

This chart maps out all the courses in the discipline and shows the links between courses and the possible prerequisites for them. It does not attempt to depict all possible movements from course to course.

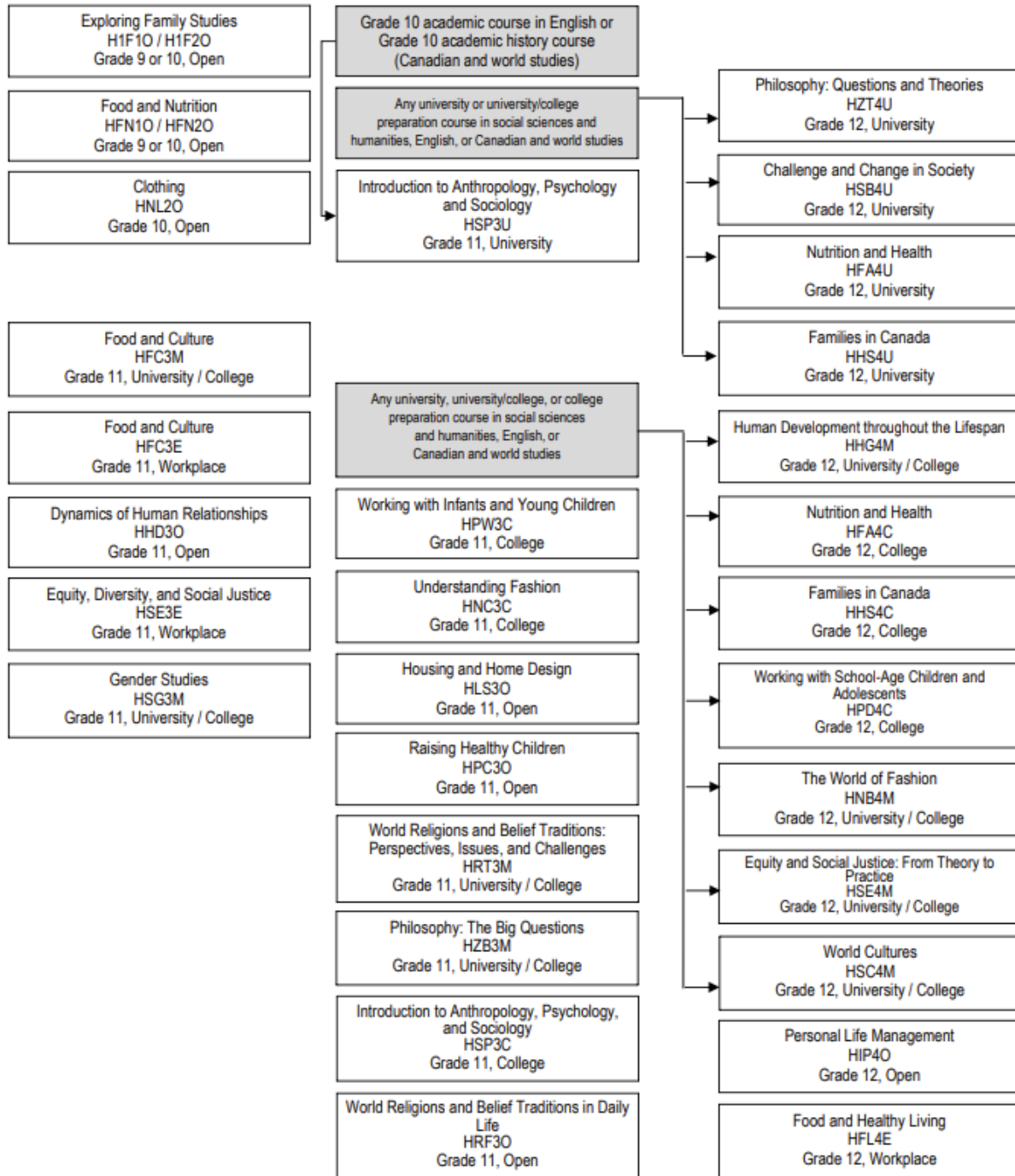

Technological Education Grades 9-10 (2024), Grades 11-12 (2009)

These charts map out all the courses in the discipline and shows the links between courses and the possible prerequisites for them. They do not attempt to depict all possible movements from course to course.

