

NOBLES



A TASMEA COMPANY

Lifting & Rigging Hardware

CATALOGUE

Table of Contents

SHACKLES..... 3

TENSIONING DEVICES..... 36

HOOKS..... 47

CONCRETE LIFTING CLUTCHES..... 59

RIGGING - OPERATION SWIFTLIFT CLUTCHES..... 61

Nobles Grade S Screw Pin Bow Shackles

Nobles are a leading stockist of Grade S shackles which are ideal for 4wd recovery. The Nobles Blue Pin shackle is manufactured to comply with the requirements of Australian Standard 2741.

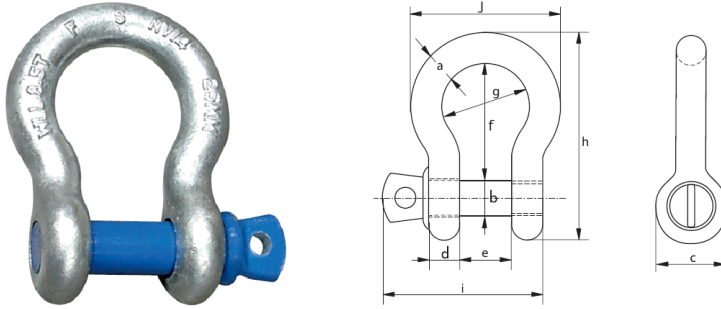

Product Specifications

Name	ITEM #	WLL (tonnes)	Size a (mm)	i (mm)	b (mm)	c (mm)	d (mm)	e (mm)	f (mm)	g (mm)	h (mm)	j (mm)	Weight (kg)
Shackle Bow 330kg 5mm Grs Blue Screw Pin Galvanised	14302	0.33	5	30	6	14	5	10	22	15	36	25	0.02
Shackle Bow 500kg 6mm Grs Blue Screw Pin Galvanised	17105	0.5	6	38	8	17	6	12	29	20	48	32	0.05
Shackle Bow 750kg 8mm Grs Blue Screw Pin Galvanised	11547	0.75	8	47	10	21	8	13	31	21	56	37	0.1
Shackle Bow 1t 10mm Grs Blue Screw Pin Galvanised	11355	1	10	54	11	25	10	17	37	26	63	46	0.14
Shackle Bow 1.5t 11mm Grs Blue Screw Pin Galvanised	10486	1.5	11	60	13	27	11	18	43	29	74	51	0.19
Shackle Bow 2t 13mm Grs Blue Screw Pin Galvanised	10434	2	13	73	16	33	13	21	48	33	89	59	0.36
Shackle Bow 3.25t 16mm Grs Blue Screw Pin Galvanised	14075	3.2	16	89	19	40	16	27	61	43	110	75	0.63
Shackle Bow 4.75t 19mm Grs Blue Screw Pin Galvanised	12407	4.7	19	103	22	48	19	32	72	51	129	89	1.01
Shackle Bow 6.5t 22mm Grs Blue Screw Pin Galvanised	18626	6.5	22	119	25	54	22	37	84	58	144	102	1.5
Shackle Bow 8.5t 25mm Grs Blue Screw Pin Galvanised	13760	8.5	25	137	29	60	25	43	95	68	164	118	2.21

Uncontrolled version printed 09-Mar-2018 .See www.nobles.com.au for latest up-to-date product information.

Nobles Grade S Safety Pin Bow Shackles

Nobles Grade S Bow Shackles are recognisable by their distinctive blue pin. All Nobles Grade 'S' bow shackles are made strictly in accordance with AS 2741 and are batch destruction tested at manufacture.

Nobles Grade S bow shackles also have raised markings which include the WLL, shackle size and batch number. This ensures shackles can be easily identified during visual inspections well into their service life.

Remember the 'Blue Pin' is your guarantee of Nobles quality.

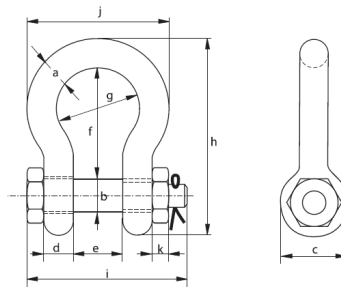

Product Specifications

Name	ITEM #	WLL (tonnes)	Size a (mm)	i (mm)	b (mm)	c (mm)	d (mm)	e (mm)	f (mm)	g (mm)	h (mm)	j (mm)	k (mm)	Weight (kg)
Shackle Safety Bow 2t 13mm Grs Blue Pin Galvanised	13896	2	13	73	16	33	13	21	48	33	89	59	13	0.36
Shackle Safety Bow 3.25t 16mm Grs Blue Pin	17348	3.2	16	89	19	40	16	27	61	43	110	75	17	0.63
Shackle Safety Bow 4.75t 19mm Grs Blue Pin Galvanised	11655	4.7	19	103	22	48	19	32	72	51	129	89	19	1.01
Shackle Safety Bow 6.5t 22mm Grs Blue Pin	16786	6.5	22	119	25	54	22	37	84	58	144	102	22	1.5
Shackle Safety Bow 8.5t 25mm Grs Blue Pin	17428	8.5	25	137	29	60	25	43	95	68	164	118	25	2.21
Shackle Safety Bow 9.5t 29mm Grs Blue Pin	14357	9.5	29	153	32	67	29	46	108	74	185	132	27	3.16
Shackle Safety Bow 12t 32mm Grs Blue Pin	15608	12	32	170	35	76	32	52	119	83	201	147	30	4.31
Shackle Safety Bow 13.5t 35mm Grs	18196	13.5	35	186	38	84	35	57	133	92	227	162	33	5.55
Shackle Safety Bow 17t 38mm Grs Blue Pin	11346	17	38	203	41	92	38	60	146	98	249	203	19	7.43
Shackle Safety Bow 25t 44mm Grs Blue Pin	15616	25	44	243	51	110	44	73	178	127	300	215	23	12.84
Shackle Safety Bow 35t 51mm Grs	13499	35	51	269	57	127	51	83	197	146	331	238	26	19.53
57MM S SAF BOW SHACKLE 42.5T	24736	42.5	57	301	63	143	57	95	222	160	377	274	29	28.33
Shackle Safety Bow 55t 63mm Grs Blue Pin	12252	55	63	330	70	152	63	105	267	184	433	310	32	39.59

Uncontrolled version printed 09-Mar-2018 .See www.nobles.com.au for latest up-to-date product information.

Nobles Grade S Screw Pin Dee Shackles

Nobles Grade S Dee Shackles are recognisable by their distinctive blue pin. All Nobles Grade 'S' dee shackles are made strictly in accordance with AS 2741 and are batch destruction tested at manufacture.

Nobles Grade S dee shackles also have raised markings which include the WLL, shackle size and batch number. This ensures shackles can be easily identified during visual inspections well into their service life.

Remember the 'Blue Pin' is your guarantee of Nobles quality.

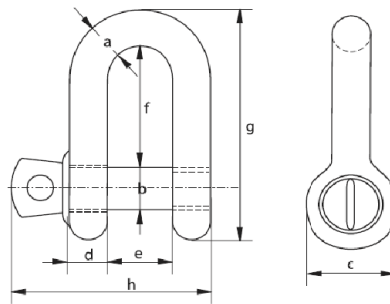

Product Specifications

Name	ITEM #	WLL (tonnes)	Size a (mm)	b (mm)	c (mm)	d (mm)	e (mm)	f (mm)	g (mm)	h (mm)	Weight (kg)
Shackle Dee 330kg 5mm Grs Blue Screw Pin	12962	0.33	5	6	14	5	10	19	33	30	0.02
Shackle Dee 500kg 6mm Grs Blue Screw Pin	19413	0.5	6	8	17	6	12	22	42	38	0.05
Shackle Dee 750kg 8mm Grs Blue Screw Pin	16403	0.75	8	10	21	8	13	26	50	47	0.09
Shackle Dee 1t 10mm Grs Blue Screw Pin	11234	1	10	11	25	10	17	32	59	54	0.14
Shackle Dee 1.5t 11mm Grs Blue Screw Pin	15877	1.5	11	13	27	11	18	37	68	60	0.19
Shackle Dee 2t 13mm Grs Blue Screw Pin	17459	2	13	16	33	13	21	41	81	73	0.32
Shackle Dee 3.25t 16mm Grs Blue Screw Pin	11530	3.2	16	19	40	16	27	51	97	89	0.54
Shackle Dee 4.75t 19mm Grs Blue Screw Pin Galvanised	19086	4.7	19	22	48	19	32	60	112	103	0.87
Shackle Dee 6.5t 22mm Grs Blue Screw Pin	12162	6.5	22	25	54	22	37	71	134	119	1.34
Shackle Dee 8.5t 25mm Grs Blue Screw Pin	11369	8.5	25	29	60	25	43	81	154	137	2.08
Shackle Dee 9.5t 29mm Grs Blue Screw Pin	14552	9.5	29	32	67	29	46	90	167	153	2.77
Shackle Dee 12t 32mm Grs Blue Screw Pin	18481	12	32	35	76	32	52	100	180	170	3.72
Shackle Dee 13.5t 35mm Grs Screw Pin	14226	13.5	35	38	84	35	57	113	209	186	5.14

Shackle Dee 17t 38mm Grs Blue Screw Pin	16772	17	38	41	92	38	60	124	230	203	6.85
Shackle Dee 25t 44mm Grs Blue Screw Pin	17191	25	44	51	110	44	73	146	271	243	11.45
Shackle Dee 35t 51mm Grs Blue Screw Pin	15625	35	51	57	127	51	83	171	305	272	16.86

Uncontrolled version printed 09-Mar-2018 .See www.nobles.com.au for latest up-to-date product information.

Green Pin Grade S Screw Pin Bow Shackles

Nobles is Australia's largest stockist and distributor of the Van Beest range of GREEN PIN shackles. Van Beest shackles are manufactured in the Netherlands and renowned worldwide for their quality and are used extensively across a wide range of industries including construction, mining and oil and gas production. Van Beest shackles are stocked to 150 tonne capacity.

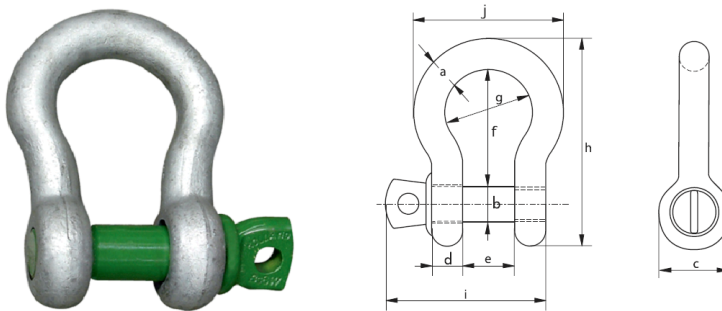

Product Specifications

Name	ITEM #	WLL (tonnes)	Size a (mm)	i (mm)	b (mm)	c (mm)	d (mm)	e (mm)	f (mm)	g (mm)	h (mm)	j (mm)	Weight (kg)
Shackle Bow 330kg 5mm Grs Green Screw Pin Galvanised	12030	0.33	5	29.5	6	12	5	9.5	22	16	36	26	0.02
Shackle Bow 500kg 7mm Grs Green Screw Pin Galvanised	10039	0.5	7	38	8	16.5	7	12	29	20	48.5	34	0.05
Shackle Bow 750kg 9mm Grs Green Screw Pin Galvanised	17787	0.75	9	46.5	10	20	9	13.5	32	22	56	40	0.1
Shackle Bow 1t 10mm Grs Green Screw Pin Galvanised	10056	1	10	54	11	22.5	10	17	36.5	26	63.5	46	0.14
Shackle Bow 1.5t 11mm Grs Green Screw Pin Galvanised	16210	1.5	11	59.5	13	26.5	11	19	43	29	74	51	0.19
Shackle Bow 2t 13mm Grs Green Screw Pin Galvanised	11888	2	13.5	73	16	34	13	22	51	32	89	58	0.36
Shackle Bow 3.25t 16mm Grs Green Screw Pin Galvanised	13553	3.25	16	89	19	40	16	27	64	43	110	75	0.63
Shackle Bow 4.75t 19mm Grs Green Screw Pin Galvanised	17560	4.75	19	103	22	46	19	31	76	51	129	89	1.01
Shackle Bow 6.5t 22mm Grs Green Screw Pin Galvanised	15637	6.5	22	119	25	52	22	36	83	58	144	102	1.5
Shackle Bow 8.5t 25mm Grs Green Screw Pin Galvanised	10360	8.5	25	137	28	59	25	43	95	68	164	118	2.21
Shackle Bow 9.5t 28mm Grs Green Screw Pin Galvanised	12276	9.5	28	153	32	66	28	47	108	75	185	131	3.16
Shackle Bow 12t 32mm Grs Green Screw Pin Galvanised	15805	12	32	170	35	72	32	51	115	83	201	147	4.31
Shackle Bow 13.5t 35mm Grs Green Screw Pin Galvanised	17409	13.5	35	186	38	80	35	57	133	92	227	162	5.55
Shackle Bow 17t 38mm Grs Green Screw Pin Galvanised	16890	17	38	203	42	88	38	60	146	99	249	175	7.43
Shackle Bow 25t 45mm Grs Green Screw Pin Galvanised	14148	25	45	243	50	103	45	74	178	126	300	216	12.84

Shackle Bow 35t 50mm Grs Green Screw Pin Galvanised	18740	35	50	272	57	111	50	83	197	138	331	238	18.15
Shackle Bow 42.5t 57mm Grs Green Screw Pin Galvanised	10446	42.5	57	310	65	130	57	95	222	160	377	274	26.29
Shackle Bow 55t 65mm Grs Green Screw Pin Galvanised	13460	55	63	344	70	145	63	105	260	180	433	310	37.6

Uncontrolled version printed 09-Mar-2018 .See www.nobles.com.au for latest up-to-date product information.

Green Pin Grade S Safety Pin Bow Shackles

Nobles is Australia's largest stockist and distributor of the Van Beest range of GREEN PIN shackles. Van Beest shackles are manufactured in the Netherlands and renowned worldwide for their quality and are used extensively across a wide range of industries including construction, mining and oil and gas production. Van Beest shackles are stocked to 150 tonne capacity.

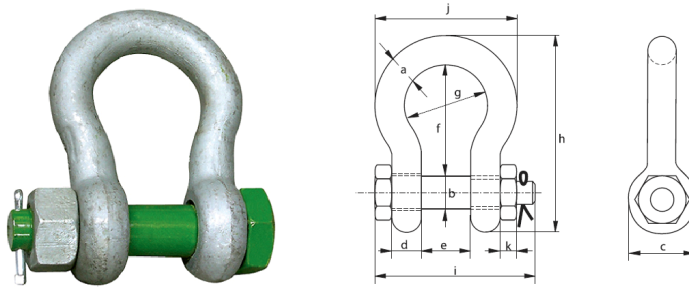

Product Specifications

Name	ITEM #	WLL (tonnes)	Size a (mm)	i (mm)	b (mm)	c (mm)	d (mm)	e (mm)	f (mm)	g (mm)	h (mm)	j (mm)	k (mm)	Weight (kg)
Shackle Safety Bow 500kg 7mm Grs Green Pin	15009	0.5	7	38	8	16.5	7	12	29	20	48.5	34	4	0.06
Shackle Safety Bow 750kg 9mm Grs Green Pin	17888	0.75	9	46.5	10	20	9	13.5	32	22	56	40	5	0.11
Shackle Safety Bow 1t 10mm Grs Green Pin	11358	1	10	54	11	22.5	10	17	36.5	26	63.5	46	8	0.16
Shackle Safety Bow 1.5t 11mm Grs Green Pin	12389	1.5	11	59.5	13	26.5	11	19	43	29	74	51	11	0.22
Shackle Safety Bow 2t 13mm Grs Green Pin	16245	2	13.5	73	16	34	13	22	51	32	89	58	13	0.42
Shackle Safety Bow 3.2t 16mm Grs Green Pin	11920	3.25	16	89	19	40	16	27	64	43	110	75	17	0.74
Shackle Safety Bow 4.7t 19mm Grs Green Pin	16879	4.75	19	103	22	46	19	31	76	51	129	89	19	1.18
Shackle Safety Bow 6.5t 22mm Grs Green Pin	15786	6.5	22	119	25	52	22	36	83	58	144	102	22	1.77
Shackle Safety Bow 8.5t 25mm Grs Green Pin	18598	8.5	25	137	28	59	25	43	95	68	164	118	25	2.58
Shackle Safety Bow 9.5t 28mm Grs Green Pin	17410	9.5	28	153	32	66	28	47	108	75	185	131	27	3.66
Shackle Safety Bow 12t 32mm Grs Green Pin	14292	12	32	170	35	72	32	51	115	83	201	147	30	4.91
Shackle Safety Bow 13.5t 35mm Grs Green Pin	14820	13.5	35	186	38	80	35	57	133	92	227	162	33	6.54
Shackle Safety Bow 17t 38mm Grs Green Pin	10970	17	38	203	42	88	38	60	146	99	249	175	19	8.19
Shackle Safety Bow 25t 45mm Grs Green Pin	10552	25	45	243	50	103	45	74	178	126	300	216	23	14.22
Shackle Safety Bow 35t 50mm Grs Green Pin	17399	35	50	272	57	111	50	83	197	138	331	238	26	19.53
Shackle Safety Bow 42.5t 57mm Grs Green Pin	13013	42.5	57	310	65	130	57	95	222	160	377	274	29	28.33
Shackle Safety Bow 55t 65mm Grs Green Pin	17600	55	63	344	70	145	63	105	260	180	433	310	32	39.59
Shackle Safety Bow 85t 75mm Grs Green Pin	12953	85	75	380	83	162	73	127	329	190	527	340	39	62

Green Pin Grade S Screw Pin Dee Shackles

Nobles is Australia's largest stockist and distributor of the Van Beest range of GREEN PIN shackles. Van Beest shackles are manufactured in the Netherlands and renowned worldwide for their quality and are used extensively across a wide range of industries including construction, mining and oil and gas production. Van Beest shackles are stocked to 150 tonne capacity.

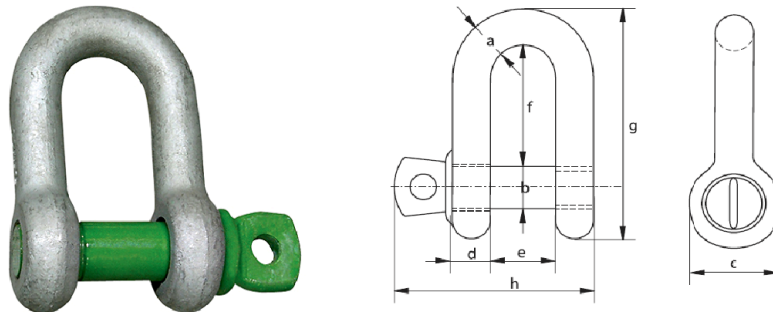

Product Specifications

Name	ITEM #	WLL (tonnes)	Size a (mm)	b (mm)	c (mm)	d (mm)	e (mm)	f (mm)	g (mm)	h (mm)	Weight (kg)
Shackle Dee 330kg 5mm Grs Green Screw Pin	12689	0.33	5	6	12	5	9.5	19	33	29.5	0.02
Shackle Dee 500kg 7mm Grs Green Screw Pin	13153	0.5	7	8	16.5	7	12	22	41.5	38	0.05
Shackle Dee 750kg 9mm Grs Green Screw Pin	12981	0.75	9	10	20	9	13.5	26	50	46.5	0.09
Shackle Dee 1t 10mm Grs Green Screw Pin	11579	1	10	11	22.5	10	17	32	59	54	0.14
Shackle Dee 1.5t 11mm Grs Green Screw Pin	12150	1.5	11	13	26.5	11	19	37	68	59.5	0.19
Shackle Dee 2t 13mm Grs Green Screw Pin	13108	2	13.5	16	34	13	22	43	81	73	0.32
Shackle Dee 3.25t 16mm Grs Green Screw Pin	15363	3.25	16	19	40	16	27	51	97	89	0.54
Shackle Dee 4.75t 19mm Grs Green Screw Pin	15803	4.75	19	22	46	19	31	59	112	103	0.87
Shackle Dee 6.5t 22mm Grs Green Screw Pin	14261	6.5	22	25	52	22	36	73	134	119	1.34
Shackle Dee 8.5t 25mm Grs Green Screw Pin	16165	8.5	25	28	59	25	43	85	154	137	2.08
Shackle Dee 9.5t 28mm Grs Green Screw Pin	14717	9.5	28	32	66	28	47	90	167	153	2.77
Shackle Dee 12t 32mm Grs Green Screw Pin	17020	12	32	35	72	32	51	94	180	170	3.72
Shackle Dee 13.5t 35mm Grs Green Screw Pin	18276	13.5	35	38	80	35	57	115	209	186	5.14

Shackle Dee 17t 38mm Grs Green Screw Pin	19477	17	38	42	88	38	60	127	230	203	6.85
Shackle Dee 25t 45mm Grs Green Screw Pin	13293	25	45	50	103	45	74	149	271	243	11.45
Shackle Dee 35t 50mm Grs Green Screw Pin	12023	35	50	57	111	50	83	171	305	272	16.86
Shackle Dee 42.5t 57mm Grs Green Screw Pin	17420	42.5	57	65	130	57	95	190	345	310	24.61
Shackle Dee 55t 65mm Grs Green Screw Pin	15569	55	63	70	145	63	105	203	376	344	32.65

Uncontrolled version printed 09-Mar-2018 .See www.nobles.com.au for latest up-to-date product information.

Green Pin Grade S Safety Pin Dee Shackles

Nobles is Australia's largest stockist and distributor of the Van Beest range of GREEN PIN shackles. Van Beest shackles are manufactured in the Netherlands and renowned worldwide for their quality and are used extensively across a wide range of industries including construction, mining and oil and gas production. Van Beest shackles are stocked to 150 tonne capacity.

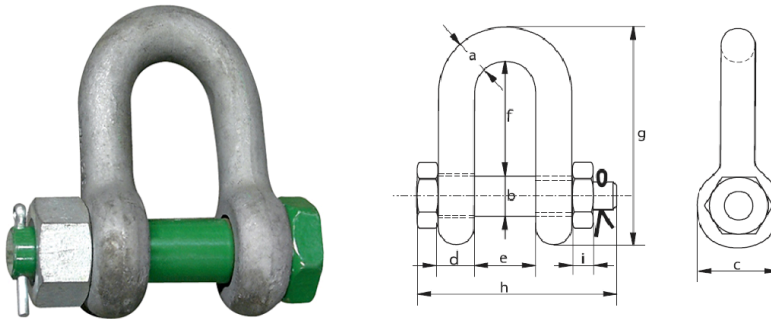

Product Specifications

Name	ITEM #	WLL (tonnes)	Size a (mm)	i (mm)	b (mm)	c (mm)	d (mm)	e (mm)	f (mm)	g (mm)	h (mm)	Weight (kg)
Shackle Safety Dee 2t 13mm Grs Green Pin	14189	2	13.5	13	16	34	13	22	43	81	82	0.39
Shackle Safety Dee 3.25t 16mm Grs Green Pin	18126	3.25	16	17	19	40	16	27	51	97	98	0.67
Shackle Safety Dee 4.75t 19mm Grs Green Pin	13826	4.75	19	19	22	46	19	31	59	112	114	1.08
Shackle Safety Dee 6.5t 22mm Grs Green Pin	11856	6.5	22	22	25	52	22	36	73	134	130	1.66
Shackle Safety Dee 8.5t 25mm Grs Green Pin	16341	8.5	25	25	28	59	25	43	85	154	150	2.46
Shackle Safety Dee 9.5t 28mm Grs Green Pin	10001	9.5	28	27	32	66	28	47	90	167	166	3.4
Shackle Safety Dee 12t 32mm Grs Green Pin	15744	12	32	30	35	72	32	51	94	180	178	4.51
Shackle Safety Dee 13.5t 35mm Grs Green Pin	15484	13.5	35	33	38	80	35	57	115	209	197	6.1
Shackle Safety Dee 17t 38mm Grs Green Pin	17980	17	38	19	42	88	38	60	127	230	202	7.63
Shackle Safety Dee 25t 45mm Grs Green Pin	10240	25	45	23	50	103	45	74	149	271	249	12.88
Shackle Safety Dee 35t 50mm Grs Green Pin	14498	35	50	26	57	111	50	83	171	305	269	17.35
Shackle Safety Dee 55t 65mm Grs Green Pin	15867	55	63	32	70	145	63	105	203	376	330	35.33
Shackle Safety Dee 85t 75mm Grs Green Pin	15207	85	75	39	83	162	73	127	229	427	380	52.97

Green Pin Heavy Duty Bow Shackles

Nobles is Australia's largest stockist and distributor of the Van Beest range of GREEN PIN shackles. Van Beest shackles are manufactured in the Netherlands and renowned worldwide for their quality and are used extensively across a wide range of industries including construction, mining and oil and gas production. Van Beest shackles are stocked to 150 tonne capacity.

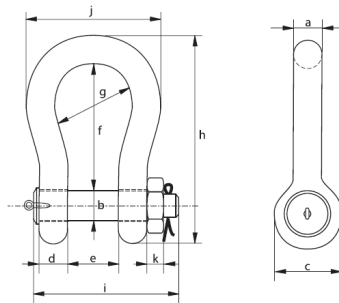

Product Specifications

Name	ITEM #	WLL (tonnes)	Size a (mm)	i (mm)	b (mm)	c (mm)	d (mm)	e (mm)	f (mm)	g (mm)	h (mm)	j (mm)	k (mm)	Weight (kg)
Shackle Safety Bow 120t 95mm Grs Green Pin Heavy Duty	15543	120	95	440	95	208	91	147	400	238	647	428	50	110
Shackle Safety Bow 150t 105mm Grs Green Pin Heavy Duty	14993	150	105	490	108	238	102	169	410	275	688	485	60	160
Shackle Safety Bow 200t 120mm Grs Green Pin Heavy Duty	14231	200	120	520	130	279	113	179	513	290	838	530	60	235

Uncontrolled version printed 09-Mar-2018 .See www.nobles.com.au for latest up-to-date product information.

Green Pin Safety Sling Shackles

Nobles is Australia's largest stockist and distributor of the Van Beest range of GREEN PIN shackles. Van Beest shackles are manufactured in the Netherlands and renowned worldwide for their quality and are used extensively across a wide range of industries including construction, mining and oil and gas production.

Van Beest sling shackles are excellent for connecting wire rope slings or synthetic webbing and round slings with the increase in bow radius providing a much improved bearing surface eliminating the need for a thimble and extending the service life of your slings.

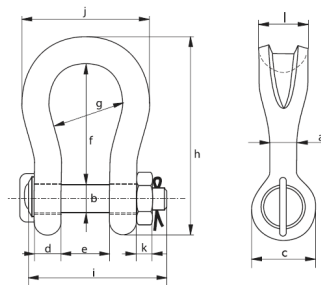

Product Specifications

Name	ITEM #	WLL (tonnes)	Size a (mm)	i (mm)	b (mm)	c (mm)	d (mm)	e (mm)	f (mm)	g (mm)	h (mm)	j (mm)	k (mm)	l (mm)	Weight (kg)
Shackle Sling Wide Body Bow 40mm 30t GrS Green Pin	26098	30	40	211	42	90	35	69	165	126	279	200	34	79	13
Shackle Sling Wide Body Bow 55mm 40t GrS Green Pin	22026	40	55	252	51	109	45	84	199	140	331	235	38	97	21
Shackle Sling Wide Body Bow 60mm 55t Grs Green Pin	24288	55	60	299	57	115	55	90	240	160	389	270	45	100	30
Shackle Sling Wide Body Bow 68mm 75t Grs Green Pin	23665	75	68	327	70	125	54	110	290	185	473	317	54	120	48
Shackle Sling Wide Body Bow 94mm 150t Grs Green Pin	15140	150	94	435	95	179	89	147	391	253	645	434	50	170	140
Shackle Sling Wide Body Bow 110mm 200t Grs Green Pin	17809	200	110	470	105	199	100	158	481	280	759	482	50	205	205
Shackle Sling Wide Body Bow 126mm 250t Grs Green Pin	14497	250	126	519	120	227	110	179	542	300	859	530	60	240	264
Shackle Sling Wide Body Bow 135mm 300t Grs Green Pin	21181	300	135	575	134	245	122	195	601	350	947	620	70	265	360
Shackle Sling Wide Body Bow 160mm 400t Grs Green Pin	16135	400	160	675	160	293	145	231	576	370	985	690	80	320	580

Uncontrolled version printed 09-Mar-2018 .See www.nobles.com.au for latest up-to-date product information.

Green Pin Grade T Super Shackles

Nobles is Australia's largest stockist and distributor of the Van Beest range of GREEN PIN shackles. Van Beest shackles are manufactured in the Netherlands and renowned worldwide for their quality and are used extensively across a wide range of industries including construction, mining and oil and gas production.

Van Beest Super Shackles are Grade T (8) alloy quenched and tempered. The MBL of Super Shackles is 5:1 enabling higher WLL's per physical size and weight compared to traditional Grade S (6) shackles.

Van Beest Super Shackles are hot dip galvanised and comply with the requirements of ASME B30.26 and the requirements of US Fed Spec RR-C-271.

Van Beest Super Shackles are easily recognisable by the distinctive green top painted section.

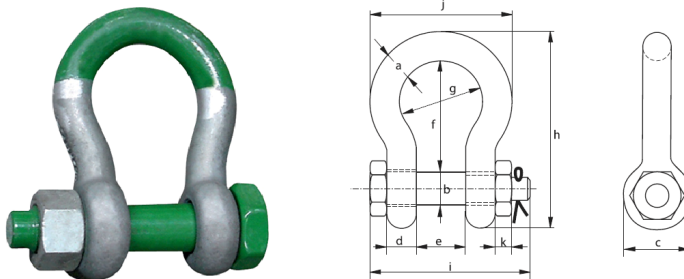

Product Specifications

Name	ITEM #	WLL (tonnes)	Size a (mm)	i (mm)	b (mm)	c (mm)	d (mm)	e (mm)	f (mm)	g (mm)	h (mm)	j (mm)	k (mm)	Weight (kg)
Shackle Super Safety Bow 13mm Grt Green Pin	13264	3.3	13.5	82	16	34	13	22	51	32	89	58	13	0.4
Shackle Super Safety Bow 16mm Grt Green Pin	19376	5	16	98	19	40	16	27	64	43	110	75	17	0.73
Shackle Super Safety Bow 7t 19mm Grt Green Pin	19503	7	19	114	22	46	19	31	76	51	129	89	19	1.19
Shackle Super Safety Bow 9.5t 22mm Grt Green Pin	13269	9.5	22	130	25	52	22	36	83	58	144	102	22	1.73
Shackle Super Safety Bow 12.5t 25mm Grt Green Pin	19451	12.5	25	150	28	59	25	43	95	68	164	118	25	2.56
Shackle Super Safety Bow 15t 28mm GrT Green Pin	17119	15	28	166	32	66	28	47	108	75	185	131	27	3.6
Shackle Super Safety Bow 18t 32mm Grt Green Pin	14040	18	32	178	35	72	32	51	115	83	201	147	30	4.95
Shackle Super Safety Bow 21t 35mm Grt Green Pin	10147	21	35	197	38	80	35	57	133	92	227	162	33	6.62
Shackle Super Safety Bow 30t 38mm GrT Green Pin	17628	30	38	217	42	88	38	60	146	99	249	175	34	8.11
Shackle Super Safety Bow 40t 45mm GrT Green Pin	23970	40	45	260	50	103	45	74	178	126	300	216	40	15
Shackle Super Safety Bow 55t 57mm GrT Green Pin	14716	55	57	303	57	117	57	83	197	138	341	252	46	23
Shackle Super Safety Bow 85t 70mm GrT Green Pin	19638	85	70	363	70	143	70	105	260	180	437	320	56	44
Shackle Super Safety Bow 120t 83mm Grt Green Pin	16622	120	83	425	83	162	83	127	329	190	535	356	66	72

Uncontrolled version printed 09-Mar-2018 .See www.nobles.com.au for latest up-to-date product information.

Grade M Screw Pin Dee Shackles

Nobles offer a range of traditional Grade M Large Dee shackles. Grade M shackles are the lowest preferred grade for lifting and are widely used in the commercial fishing and marine industries.

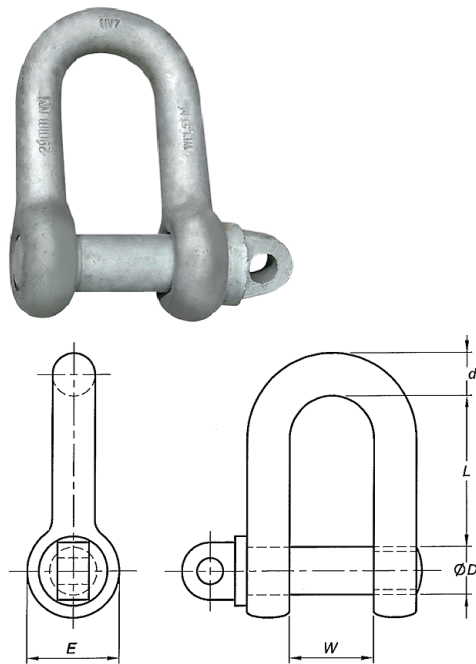

Product Specifications

Name	ITEM #	WLL (tonnes)	Size d (mm)	D (mm)	w (mm)	L (mm)	e (mm)	Weight (kg)
Shackle Large Dee 250kg 6mm Grm Galvanised	18479	0.25	6	10	13	25	19	0.05
Shackle Large Dee 500kg 10mm Grm Galvanised	13897	0.5	10	13	19	38	25	0.19
Shackle Large Dee 750kg 13mm Grm Galvanised	17396	0.75	13	16	28	54	32	0.32
Shackle Large Dee 1.5t 16mm Grm Galvanised	17376	1.5	16	19	32	63	38	0.54
Shackle Large Dee 2t 19mm Grm Galvanised	13126	2	19	22	38	73	44	0.87
Shackle Large Dee 3t 22mm Grm Galvanised	10619	3	22	25	44	83	51	1.34
Shackle Large Dee 3.8t 25mm Grm Galvanised	11337	3.8	25	29	51	95	57	2.08
Shackle Large Dee 5t 29mm Grm Galvanised	11086	5	29	32	54	105	63	2.77
Shackle Large Dee 6t 32mm Grm Galvanised	12854	6	32	35	60	114	70	3.72

Uncontrolled version printed 09-Mar-2018 .See www.nobles.com.au for latest up-to-date product information.

General

Shackles are used in lifting static systems as removable links to connect wire rope, chain and other fittings.

Shackle Types

Grade 'M' Large Dee and Grade 'S' Dee and Bow shackles are the most common types of rated lifting shackles that will be encountered in general industry.

Grade 'S' shackles are available with various pin configurations but the two main pin configurations are the 'Safety Pin' and the 'Screw Pin'.

Shackle Loading

The Working Load Limit on a shackle varies according to the angle of the load.

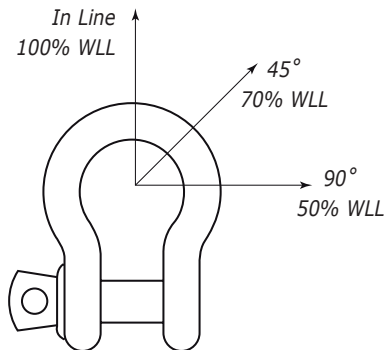

Inspection Before Use

WARNING

- Lifting equipment should be inspected before each use.

The pre-use check for shackles should ensure that:

1. The body of the shackle and pin are both compatible and are of the same grade and material.
2. All markings are clearly legible.
3. The pin is the correct type for the shackle body.
4. The threads of the pin and the shackle body are in good order and function correctly.
5. The body and pin are not damaged in any way and are free from distortion, nicks, gouges, cracks and excessive wear and corrosion. (Recommended maximum wear allowance is 10%).
6. For 'Safety pin' shackles ensure that the nuts and split pins are fitted and in good condition.

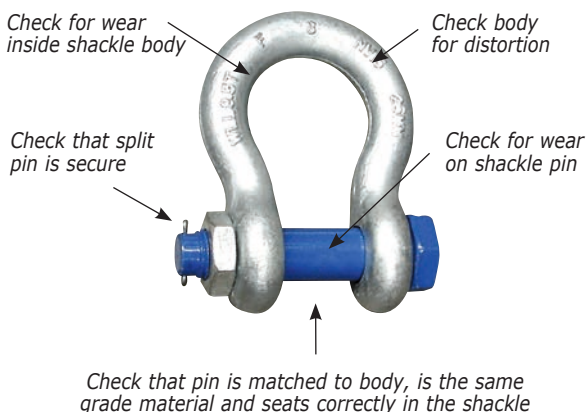

Marking

Shackles designed and tested in accordance with Australian Standard 2741 should be marked with the following

- WLL.
- Manufactures identification.
- Grade of material.
- Identification mark or batch number to cross reference the shackle to the manufacturers test certificate.

Care In Use

WARNING

- Shackles should always be used in line with good lifting and rigging practice and as per the manufacturers recommendations.
- Incorrect shackle use could result in a dangerous situation that could cause property damage, serious injury or death.
- When using shackles in multi-leg slings, due consideration should be given to the effect of the angle between the legs. As the included angle increases so to does the load in the sling leg and the shackle.
- Shackles should never be used on a sling with an included angle in excess of 120°.

1. With a screw pin shackle ensure that the pin is firmly screwed into the shackle eye. The collar of the pin should be fully seated on the shackle eye. The pin can be locked using a small spanner or tommy bar. When using a safety pin shackle ensure that the nut and split pin are attached and in good condition.
2. Ensure that the pin is of the correct length so that it penetrates the full depth of the screwed eye and allows the collar of the pin to bed on the surface of the shackle eye.
3. If the shackle pin does not seat correctly this indicates that the pin may be bent, the thread is not correct or compatible or the pinholes are not aligned correctly. The shackle should not be used under these circumstances.
4. Never replace a shackle pin with a bolt. The original shackle pin is specifically designed for the purpose and a bolt may not be suited to the WLL of the shackle.
5. Safety pin shackles must never be used if the nut and split pin are not in place.
6. Select the correct type of shackle for the intended use and application. Shackles should be fitted to the load in a manner that allows the shackle to be loaded along its centre line. Shackles should never be loaded in such a way that inappropriate bending forces are induced.
7. To avoid eccentric loading of the shackle a loose spacer may be used in either end of the shackle pin or a shackle with a smaller jaw width should be used. Do not reduce the width between the shackle jaws by welding washers or spacers to the inside face of the eyes or by closing the jaws, as this will have an adverse affect on the mechanical properties of the shackle.
8. If a shackle is being used to secure the top block of a sheave block or "handy billy" arrangement it should be noted that the hoisting effort used to pull down on the load rope also needs to be allowed for when selecting the shackle WLL.
9. The WLL of shackles is affected at high temperatures therefore the WLL's should be reduced by 10% for temperatures between 200 and 300°C and by 25% for temperatures between 300 and 400°C. Grade S Shackles should not be used at all for temperatures above 400°C.
10. Do not attempt to weld or apply heat to shackles.

RUD®

ABA Weld-On

The new ABA weld-on lifting point from RUD is the safer alternative which enables the user to take the guess work out of lifting safely.

- Manufactured in Germany using high tensile CrNiMo - steel
- 100% Electro-magnetic crack detection tested
- Complies with EN 1677
- Offers a full WLL in any direction with 4:1 design factor
- Temperature Range -40oC to 200oC no reduction in WLL
- Full working load in all directions
- Patented wear markings on the inside and on the outside

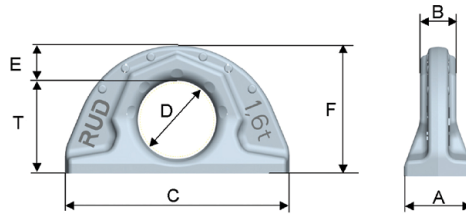

Product Specifications

Name	ITEM #	WLL F1 (tonnes)	WLL F2 (tonnes)	A (mm)	B (mm)	C (mm)	D (mm)	E (mm)	F (mm)	T (mm)	Weight (kg)
Load Ring ABA Weld On 1.6t	19163	4	1.6	30	16	100	35	16	57	41.5	0.44
Load Ring ABA Weld On 3.2t	14981	9	3.2	41	23	137	50	21	80	59	1.1
Load Ring ABA Weld On 5t	18803	12	5	51	27	172	60	27.5	99	71.5	2.3
Load Ring ABA Weld On 10t	11266	20	10	70	38	228	80	35	130	95	5.3
Load Ring Weld on ABA 20t	22539	20	20	90	52	272	115	40	175	135	10.7

Collared Eyebolts

AS 2317:1998

6:1 Safety Factor

Manufactured using only heat certified Australian Steel

Available on Request:

Special Thread forms

Hot Dip Galvanizing, Zinc Passivating, Zinc Plating, Chrome Plating, Powder Coating

Testing and Certification

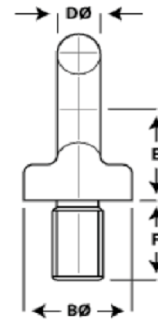
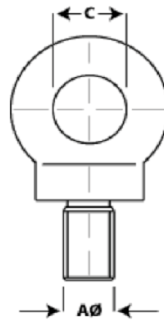

Product Specifications

Name	ITEM #	WLL (tonnes)	A (mm)	B (mm)	C (mm)	D (mm)	E (mm)	F (mm)	Weight (kg)
Eyebolt Collared M10 1.5mm Pitch Nobles Blue	13275	0.25	10	21	14	9	19	17	0.06
Eyebolt 3/8in BSW	13696	0.25	9.525	21	14	9	19	17	0.06
Eyebolt Collared M12 1.75mm Pitch Nobles Blue	18248	0.4	12	28	18	11	24	22	0.15
Eyebolt 1/2in BSW	11641	0.4	12.7	28	18	11	24	22	0.15
Eyebolt 5/8in BSW	14659	0.8	15.875	35	24	15	31	27	0.28
Eyebolt Collared M16 2.0mm Pitch Nobles Blue	15107	0.8	16	35	24	15	31	27	0.28
Eyebolt 3/4in BSW	15953	1.6	19.05	42	29	16	35	40	0.46
Eyebolt Collared M20 2.5mm Pitch Nobles Blue	11202	1.6	20	42	29	16	35	40	0.46
Eyebolt Collared M22 2.5mm Pitch	11134	2	22	50	33	20	41	41	0.85
Eyebolt 7/8in BSW	18050	2	22.22	50	33	20	41	41	0.85
Eyebolt 1in BSW	18253	2.5	25.4	57	38	22	48	42	1.1
Eyebolt Collared M24 3.0mm Pitch Nobles Blue	16163	2.5	24	57	38	22	48	42	1.1
Eyebolt 1 1/4in BSW	19249	4	31.75	71	48	28	65	52	2.1

Eyebolt Collared M30 3.5mm Pitch	10784	4	30	71	48	28	65	52	2.1
Eyebolt Collared M39 4.0mm Pitch	10457	7	39	86	54	33	73	64	3.7
Eyebolt 1 1/2in BSW	13481	7	38.1	86	54	33	73	64	3.7
Eyebolt Collared M36 4.0mm Pitch	17183	6.3	36	86	54	33	73	63	3.7
Eyebolt 2in BSW	13629	10	50.8	115	76	49	99	89	9.5
Eyebolt Collared M48 5.0mm Pitch	10598	10	48	115	76	49	99	89	9.5

Uncontrolled version printed 09-Mar-2018 .See www.nobles.com.au for latest up-to-date product information.

Eyebolts - Collared lifting AS2317

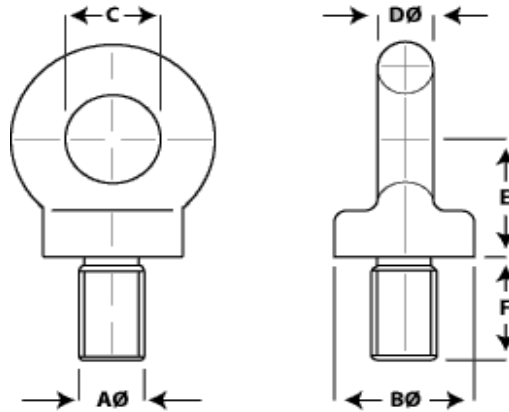

Imperial AØ	Metric AØ	BØ	C	DØ	E	F	Net Weight (kg)
3/8"	M10	21	14	9	19	17	0.06
1/2"	M12	28	18	11	24	22	0.15
5/8"	M14	35	24	15	31	27	0.28
5/8"	M16	35	24	15	31	27	0.28
3/4"	M18	42	29	16	35	40	0.46
3/4"	M20	42	29	16	35	40	0.46
7/8"	M22	50	33	20	41	41	0.85
1"	M24	57	38	22	48	42	1.10
1 1/4"	M30	71	48	28	65	52	2.10
1 1/4"	M33	71	48	28	65	52	2.10
1 1/2"	M36	86	54	33	73	63	3.70
1 1/2"	M39	86	54	33	73	64	3.70
1 3/4"	M42	102	68	40	90	79	6.30
2"	M48	115	76	49	99	89	9.50
2 1/2"	M56	143	97	56	124	116	19.50
2 1/2"	M64	143	97	56	124	116	19.50
3"	M76	163	98	66	140	125	29.00

Townley Drop Forge Pty Ltd

96 John Street, P.O. Box 12, Brunswick East, Victoria, 3057

Tel: +61 3 9387 4155 Fax: +61 3 9387 3685

Email: sales@townleydropforge.com.au Web: www.townleydropforge.com.au

General

Our Collared Eyebolts are fully compliant with AS 2317 and are of the highest quality whilst still maintaining a very competitive pricing position in the market.

The information and specifications attached here are for metric eyebolts but imperial eyebolts in BSW or UNC are stocked in some branches and are usually available. Eye nuts may also be available.

As collared eyebolts are suitable for a number of applications, the following Care in Use information should be taken as a general guide.

WARNING

- Eyebolts should always be used in accordance with Australian Standards and the manufacturers recommendations.
- When eyebolts are used the load should always be tethered to prevent it from spinning.

Inspection Before Use

The pre-use check for eyebolts should include the following:

1. Ensure the WLL is clearly legible.
2. Clean eyebolt and check for any signs of deformation, cracking, nicks, gouges and excessive bruising, wear or corrosion.
3. Threads should be concentric and fit neatly into a standard nut.
4. Check that the centre line of the eye is aligned with the centre line of the thread.
5. The threaded hole in which the eyebolt is to be fitted should also be carefully checked to ensure the hole is free from dirt, grease and other contaminants that could restrict the eyebolts from seating correctly in the hole. Particular attention should be paid to the hole thread to ensure it is in good condition.
6. Check that the hole thread and the eyebolt thread are compatible.
7. It is important to also carefully check the surface area around the threaded hole (which the eyebolt collar will sit on) to ensure it is clean, free from deformation, cracking or any other problem that may restrict the eyebolt seating correctly.

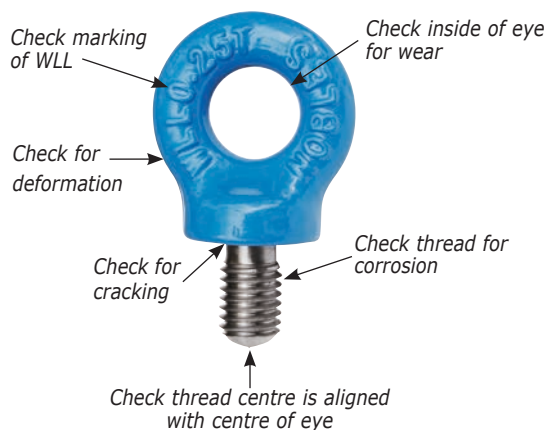

WARNING

- The WLL for eyebolts is in the direct vertical lifting plane.
- Eyebolts used in multi leg assemblies must be derated.

Care In Use

Small Eyebolts

Normally, eyebolts of sizes smaller than 12mm should not be used for general lifting, staying or tensioning purposes, as high torsional stresses are easily induced in these smaller sizes by being screwed up too tightly. Therefore, where they are used, care should be taken to not cause excessive torsional stresses while they are being fitted to a threaded hole.

Matching of Threads

Extreme care should be taken to ensure that eyebolts are not screwed into threaded holes of a different size or type of thread. Accidents may be caused by eyebolts with metric threads being screwed inadvertently into tapped holes having a BSW or UNC thread and vice versa. Apart from force fits, the thread sizes listed in the table below may be wrongly matched with the risk that the eyebolt may pull out of the threaded hole below the design load.

The possibility of mixing threads has always existed, but it has been accentuated by the change to metric threads. Where an eyebolt is removed from a threaded hole, it is recommended that the surface adjacent to the threaded hole be marked with the thread type and size and a plug be inserted into the threaded hole, or that other equally effective action be taken to reduce the possibility of mismatching threads. Where an eyebolt cannot be screwed by hand, the cause of the tight fit may be mixed threads.

Common Erroneously Matched Thread Sizes

Metric Eyebolt	BSW and UNC hole Inches
M12	1/2"
M20	7/8"
M24	1"
M30	1 1/4"
M36	1 1/2"
M42	1 3/4"
M48	2"
M56	2 1/4"
M64	2 3/4"
M72	3"

Storage

Eyebolts should always be stored in a clean, dry and well ventilated environment and in such a way that the threads are protected.

Threaded Attachment

Where an eyebolt is used in an untapped hole, the thread should engage a nut with a thread length of at least the full thickness of a standard sized nut.

Where an eyebolt is used with a tapped hole in a plate the length of thread engagement should be at least the nominal diameter of the thread. Where the undercut is not sufficient to allow for an adequate engagement of the collar, a parallel washer beneath the collar should be used so that an adequate engagement is achieved.

If the nut side of the eyebolt is on a tapered surface, such as the inside flange of an RSJ beam, then a tapered washer should be used.

Tightening Of Eyebolts

Eyebolts should be screwed fully down to the face of the lifted load; however, excessive tightening of the eyebolt should be avoided. It should not be possible to enter a 0.04 mm feeler gauge at any position between the collar of an eyebolt and its seating. Where this condition is not achieved, any non-axial loading may overstress the screw thread.

Alignment Of Eye

Where correct alignment of the eye of an eyebolt is required but not accomplished at the first fitting, it should be achieved by the following methods:

- Fitting a shim washer of steel under the collar. A shim washer should not be less in diameter than the diameter of the collar, and the thickness should be between 50% and 100% of the pitch of the threaded shank.
- Machining the underside of the collar. The amount of material machined from the collar should not exceed 50% of the pitch of the thread on the shank of the eyebolt.

Continuous Slings

A continuous sling should not be used with pairs of eyebolts. Where a continuous sling is used with a pair of eyebolts, the load applied to the eyebolts is considerably increased by the tension in the horizontal portion of the sling and this may overstress the eyebolts. Whenever lifting with eyebolts in pairs supported by slings, always use rigging assemblies with individual sling lengths.

Loading Not Aligned With Threaded End

Where the centre-line of loading is not in line with the axis of the threaded end of the eyebolt, including where a two-leg sling is connected to a pair of eyebolts to support a load, the following apply:

- The diameter of the boss of the tapped hole, into which the eyebolt is screwed, should be no less than the diameter of the collar of the eyebolt.
- The angle between the centre-line of the loading on the eye of the eyebolt and the plane containing the eye of the eyebolt should not exceed 5°, unless an adequate reduction is made to the WLL.

Where the perpendicular loading is applied (sometimes called 'trunnion lifting'), the eye of the eyebolt should be aligned in the vertical plane.

Where two pairs of eyebolts are fitted to a single item, lifting should be effected by means of two two-leg slings and a spreader bar to ensure the load is distributed evenly across the eyebolts. This arrangement also allows the load to be readily applied to each eyebolt in the plane of the eye.



WARNING

Where a single eyebolt is used care should be taken to ensure that it remains screwed home throughout the lifting operation. If a single eyebolt is used for lifting and there is a possibility that the load will rotate or twist, a swivel should be used in the system to prevent the eyebolt unscrewing.

Attachment of slings

Eyebolts are not designed to have hooks attached directly to them. An approved shackle should always be fitted to the eyebolt and the slings are then attached to the shackle.



WARNING

- Never lift with an eyebolt that is not correctly seated on its collar. A dangerous condition is created when incorrectly seated eyebolts are loaded.
- Never use excessive leverage to tighten an eyebolt. Excessive tightening will cause stretching and deformation of the thread resulting in a dangerous condition.

Working Load Limits On Pairs Of Eyebolts

The Working Load Limits specified in the Australian Standard applies to a direct vertical loading. Where eyebolts are used in pairs and the lift is taken by means of two-legged slings, allowance must be made for the angle between the sling legs, and the Working Load Limit decreased accordingly.

The table on the following page indicates Working Load Limit of two-legged slings with included angles of 30°, 60° and 90°, with the comparative value when the load is carried through a single eyebolt.

The load applied to eyebolts, when used in pairs and threaded with continuous slings, is increased considerably by the tension in the horizontal portion of the slings. It is most important, therefore, that continuous slings are not used. Correct and incorrect methods are indicated.

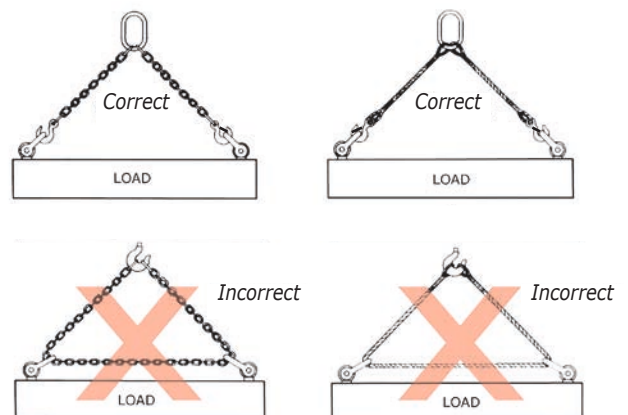

Correct and incorrect methods of pairing sling legs with eye bolts

Eye & Eye Rigging Screws

Rigging screws are used to provide a means for length adjustment and for tensioning. They are also used with guys for masts, towers, other structures and engineering applications. Rigging screws generally have elongated eyes or clevis (Jaw) end fittings for connection to shackles, wire rope assemblies, pad eyes and the like. A central cross-hole is provided at the inner end of the thread and at each end of the body, which permits visual observation of the maximum permitted extended position of the end fitting. Rigging screw bodies are formed from tubular sections of steel and can have an almost infinite size range and scope for length adjustment. Size and adjustment of rigging screws is limited by the available end fittings. Additionally, rigging screws have the innate facility for continuing lubrication as the enclosed section of the body provides a suitable reservoir for grease or other lubrication. Hence, they have an advantage in relative corrosive applications such as ships rigging and permanent outdoor guys.

Grades

Rigging Screws and Turnbuckles in accordance with Australian Standards are available in various grades. The standard Nobles grade of supply is Grade P. Other grades (S and L) are available and some stocks may be held in specific sizes.

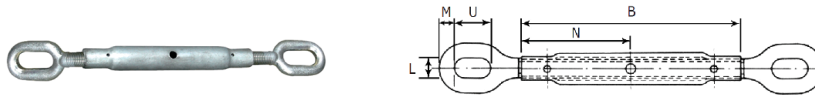

Product Specifications

Name	ITEM #	Size (mm)	WLL (tonnes)	B (mm)	N (mm)	L (mm)	U (mm)	M (mm)	Open (mm)	Closed (mm)	Weight (kg)
M64 GrP 32t Eye and Eye Rigging Screw	25144	64	32	410	210	62	117	49	937	800	35
M56 GrP 25t Eye and Eye Rigging Screw	25126	56	25	415	210	58	114	44	1015	805	25
M48 GrP 16t Eye and Eye Rigging Screw	25047	48	16	405	215	44	96	38	938	748	18
M42 GrP 12t Eye and Eye Rigging Screw	25115	42	12	410	205	42	87	31	892	680	13.2
M39 GrP 10t Eye and Eye Rigging Screw	25024	39	10	415	205	38	75	29	851	653	11
M33 GrP 8t Eye and Eye Rigging Screw	25179	33	8	385	195	36	66	26	832	600	8.95
M27 GrP 5t Eye and Eye Rigging Screw	25000	27	5	360	180	28	57	19	815	576	6.57
M24 GrP 4t Eye and Eye Rigging Screw	25105	24	4	360	180	25	51	19	783	530	3.86
M20 GrP 2.5t Eye and Eye Rigging Screw	25134	20	2.5	230	120	21	49	16	540	385	2.36
M16 GrP 1.6t Eye and Eye Rigging Screw	25053	16	1.6	230	123	17	39	14	539	374	1.31
M12 GrP 1t Eye and Eye Rigging Screw	24966	12	1	230	115	14	29	11	514	338	0.77

Uncontrolled version printed 09-Mar-2018 .See www.nobles.com.au for latest up-to-date product information.

Jaw & Eye Rigging Screws

Rigging screws are used to provide a means for length adjustment and for tensioning. They are also used with guys for masts, towers, other structures and engineering applications. Rigging screws generally have elongated eyes or clevis (Jaw) end fittings for connection to shackles, wire rope assemblies, pad eyes and the like. A central cross-hole is provided at the inner end of the thread and at each end of the body, which permits visual observation of the maximum permitted extended position of the end fitting. Rigging screw bodies are formed from tubular sections of steel and can have an almost infinite size range and scope for length adjustment. Size and adjustment of rigging screws is limited by the available end fittings. Additionally, rigging screws have the innate facility for continuing lubrication as the enclosed section of the body provides a suitable reservoir for grease or other lubrication. Hence, they have an advantage in relative corrosive applications such as ships rigging and permanent outdoor guys.

Grades

Rigging Screws and Turnbuckles in accordance with Australian Standards are available in various grades. The standard Nobles grade of supply is Grade P. Other grades (S and L) are available and some stocks may be held in specific sizes.

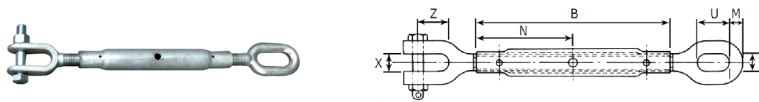

Product Specifications

Name	ITEM #	Size (mm)	WLL (tonnes)	B (mm)	N (mm)	L (mm)	U (mm)	M (mm)	X (mm)	Z (mm)	Open (mm)	Closed (mm)	Weight (kg)
M64 GrP 32t Jaw and Eye Rigging Screw	25129	64	32	410	210	62	117	49	74	140	940	805	39.6
M56 GrP 25t Jaw and Eye Rigging Screw	25042	56	25	415	210	58	114	44	70	144	935	755	33.6
M48 GrP 16t Jaw and Eye Rigging Screw	25146	48	16	405	215	44	96	38	54	127	935	755	24
M42 GrP 12t Jaw and Eye Rigging Screw	25066	42	12	410	205	42	87	31	57	112	907	689	18.6
M39 GrP 10t Jaw and Eye Rigging Screw	25065	39	10	415	205	38	75	29	53	96	878	670	12.8
M33 GrP 8t Jaw and Eye Rigging Screw	25022	33	8	385	195	36	66	26	35	78	826	595	10.5
M27 GrP 5t Jaw and Eye Rigging Screw	25084	27	5	360	180	28	57	19	31	73	808	574	7.8
M24 GrP 4t Jaw and Eye Rigging Screw	25008	24	4	360	180	25	51	19	30	60	778	530	4.65
M20 GrP 2.5t Jaw and Eye Rigging Screw	25191	20	2.5	230	120	21	49	16	24	52	545	381	2.54
M16 GrP 1.6t Jaw and Eye Rigging Screw	24968	16	1.6	230	123	17	39	14	23	51	543	375	1.49
M12 GrP 1t Jaw and Eye Rigging Screw	25090	12	1	230	115	14	29	11	20	36	515	338	0.83

Uncontrolled version printed 09-Mar-2018 .See www.nobles.com.au for latest up-to-date product information.

Jaw & Jaw Rigging Screws

Rigging screws are used to provide a means for length adjustment and for tensioning. They are also used with guys for masts, towers, other structures and engineering applications. Rigging screws generally have elongated eyes or clevis (Jaw) end fittings for connection to shackles, wire rope assemblies, pad eyes and the like. A central cross-hole is provided at the inner end of the thread and at each end of the body, which permits visual observation of the maximum permitted extended position of the end fitting. Rigging screw bodies are formed from tubular sections of steel and can have an almost infinite size range and scope for length adjustment. Size and adjustment of rigging screws is limited by the available end fittings. Additionally, rigging screws have the innate facility for continuing lubrication as the enclosed section of the body provides a suitable reservoir for grease or other lubrication. Hence, they have an advantage in relative corrosive applications such as ships rigging and permanent outdoor guys.

Grades

Rigging Screws and Turnbuckles in accordance with Australian Standards are available in various grades. The standard Nobles grade of supply is Grade P. Other grades (S and L) are available and some stocks may be held in specific sizes.

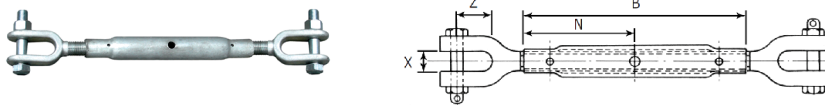

Product Specifications

Name	ITEM #	Size (mm)	WLL (tonnes)	B (mm)	N (mm)	X (mm)	Z (mm)	Open (mm)	Closed (mm)	Weight (kg)
M12 GrP 1t Jaw and Jaw Rigging Screw	25014	12	1	230	115	20	36	516	335	0.85
M16 GrP 1.6t Jaw and Jaw Rigging Screw	25088	16	1.6	230	123	23	51	544	380	1.51
M20 GrP 2.5t Jaw and Jaw Rigging Screw	25121	20	2.5	230	120	24	52	550	384	2.62
M24 GrP 4t Jaw and Jaw Rigging Screw	25190	24	4	360	180	30	60	761	521	5.16
M27 GrP 5t Jaw and Jaw Rigging Screw	25030	27	5	360	180	31	73	788	562	8.8
M33 GrP 8t Jaw and Jaw Rigging Screw	25080	33	8	360	180	31	73	813	590	11.6
M39 GrP 10t Jaw and Jaw Rigging Screw	25036	39	10	415	205	53	96	906	682	14.2
M42 GrP 12t Jaw and Jaw Rigging Screw	25095	42	12	410	205	57	112	925	702	20.8
M48 GrP 16t Jaw and Jaw Rigging Screw	25195	48	16	405	212	54	127	944	755	24
M56 GrP 25t Jaw and Jaw Rigging Screw	25198	56	25	415	210	70	144	1005	800	34.5
M64 GrP 32t Jaw and Jaw Rigging Screw	25073	64	32	410	210	70	140	940	800	41.3

Uncontrolled version printed 09-Mar-2018 .See www.nobles.com.au for latest up-to-date product information.

Eye & Eye Turnbuckles

Turnbuckles have the same applications as rigging screws, but have a generally smaller size range and shorter adjustment. The main benefit of a turnbuckle is that it may have a greater ability to be tightened under load. Also, there may be a wider scope for providing means for locking while in service.

Grades

Rigging Screws and Turnbuckles in accordance with Australian Standards are available in various grades. The standard Nobles grade of supply is Grade P. Other grades (S and L) are available and some stocks may be held in specific sizes.

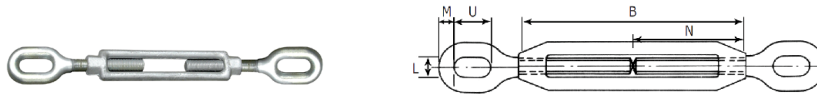

Product Specifications

Name	ITEM #	Size (mm)	WLL (tonnes)	B (mm)	N (mm)	L (mm)	U (mm)	M (mm)	Open (mm)	Closed (mm)	Weight (kg)
M33 GrP 8t Eye and Eye Turnbuckle	24979	33	8	275	195	36	66	26	651	481	14.2
M27 GrP 5t Eye and Eye Turnbuckle	25114	27	5	257	180	28	57	19	645	491	9.28
M24 GrP 4t Eye and Eye Turnbuckle	25058	24	4	227	180	25	51	19	573	418	4.35
M20 GrP 2.5t Eye and Eye Turnbuckle	24995	20	2.5	218	120	21	49	16	528	383	4.31
M16 GrP 1.6t Eye and Eye Turnbuckle	25182	16	1.6	202	123	17	39	14	520	368	2.03
M12 GrP 1t Eye and Eye Turnbuckle	25113	12	1	190	115	14	29	11	474	329	0.81

Jaw & Eye Turnbuckles

Turnbuckles have the same applications as rigging screws, but have a generally smaller size range and shorter adjustment. The main benefit of a turnbuckle is that it may have a greater ability to be tightened under load. Also, there may be a wider scope for providing means for locking while in service.

Grades

Rigging Screws and Turnbuckles in accordance with Australian Standards are available in various grades. The standard Nobles grade of supply is Grade P. Other grades (S and L) are available and some stocks may be held in specific sizes.

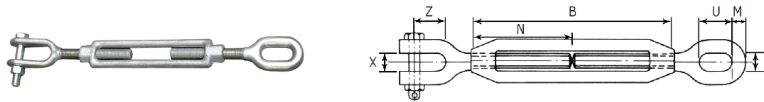

Product Specifications

Name	ITEM #	Size (mm)	WLL (tonnes)	B (mm)	N (mm)	L (mm)	U (mm)	M (mm)	X (mm)	Z (mm)	Open (mm)	Closed (mm)	Weight (kg)
M33 GrP 8t Jaw and Eye Turnbuckle	25188	33	8	275	195	36	66	26	35	78	659	497	13.1
M27 GrP 5t Jaw and Eye Turnbuckle	25039	27	5	257	180	28	57	19	31	73	631	468	10.4
M24 GrP 4t Jaw and Eye Turnbuckle	25123	24	4	227	180	25	51	19	30	60	557	405	4.66
M20 GrP 2.5t Jaw and Eye Turnbuckle	25175	20	2.5	218	120	21	49	16	24	52	527	383	4.35
M16 GrP 1.6t Jaw and Eye Turnbuckle	25016	16	1.6	202	123	17	39	14	23	51	527	377	2.28
M12 GrP 1t Jaw and Eye Turnbuckle	24967	12	1	190	115	14	29	11	20	39	479	337	0.88

Jaw & Jaw Turnbuckles

Turnbuckles have the same applications as rigging screws, but have a generally smaller size range and shorter adjustment. The main benefit of a turnbuckle is that it may have a greater ability to be tightened under load. Also, there may be a wider scope for providing means for locking while in service.

Grades

Rigging Screws and Turnbuckles in accordance with Australian Standards are available in various grades. The standard Nobles grade of supply is Grade P. Other grades (S and L) are available and some stocks may be held in specific sizes.

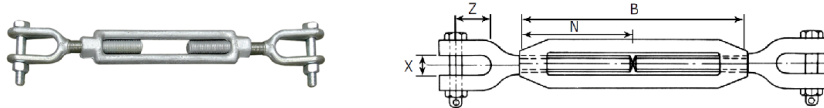

Product Specifications

Name	ITEM #	Size (mm)	WLL (tonnes)	B (mm)	N (mm)	X (mm)	Z (mm)	Open (mm)	Closed (mm)	Weight (kg)
Turnbuckle M12 GrP 1t Jaw and Jaw	25011	12	1	190	115	20	36	479	334	1.5
M16 GrP 1.6t Jaw and Jaw Turnbuckle	25168	16	1.6	202	123	23	51	525	380	2.32
M20 GrP 2.5t Jaw and Jaw Turnbuckle	25004	20	2.5	218	120	24	52	530	384	4.57
M24 GrP 4t Jaw and Jaw Turnbuckle	25075	24	4	227	180	30	60	545	397	8.4
M27 GrP 5t Jaw and Jaw Turnbuckle	25111	27	5	257	180	31	73	626	464	9.2
M33 GrP 8t Jaw and Jaw Turnbuckle	25083	33	8	275	195	35	78	663	497	13.6

Rigging Screws

Rigging screws are used to provide a means for length adjustment and for tensioning. They are also used with guys for masts, towers, other structures and engineering applications. Rigging screws generally have elongated eyes or clevis end fittings for connection to shackles, wire rope assemblies, pad eyes and the like. A central cross-hole is provided at the inner end of the thread and at each end of the body, which permits visual observation of the maximum permitted extended position of the end fitting. Rigging screw bodies are formed from tubular sections of steel and can have an almost infinite size range and scope for length adjustment. Size and adjustment of rigging screws is limited by the available end fittings. Additionally, rigging screws have the innate facility for continuing lubrication as the enclosed section of the body provides a suitable reservoir for grease or other lubrication. Hence, they have an advantage in relative corrosive applications such as ships rigging and permanent outdoor guys.

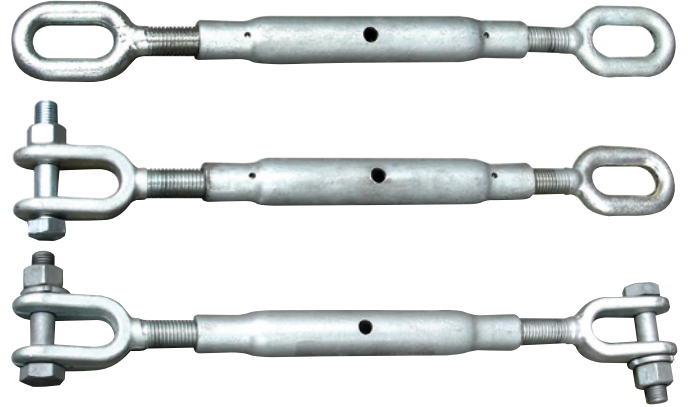

Turnbuckles

Turnbuckles have the same applications as rigging screws, but have a generally smaller size range and shorter adjustment. The main benefit of a turnbuckle is that it may have a greater ability to be tightened under load. Also, there may be a wider scope for providing means for locking while in service.

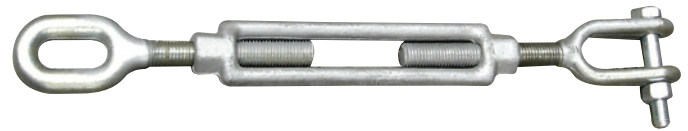

Rigging Screw Grade

Rigging Screws and Turnbuckles in accordance with Australian Standards are available in various grades. The standard Nobles grade of supply is Grade P. Other grades (S and L) are available and some stocks may be held in specific sizes.

Grade L

Grade L is the original grade of supply for rigging screws. It is from this grade that most of the dimensions of standard rigging screw components are derived. The load ratings of Grade L rigging screws equate to slightly better than mild steel. Although Grade L rigging screws are still favoured in the commercial fishing industry it is now generally an obsolete grade for rigging screws. The use of Grade L rigging screws is now generally limited to stud ended rigging screws which must be soft enough to swage and stub ended rigging screws where weldability is required.

Grade P

Grade P is obtained using Nobles carefully developed heat treatment process. This grade is intended to reduce the size of rigging screws or turnbuckles required for a given load or application. The many benefits of Grade P include high strength and appropriate size and fitment with modern wire rope and accessories. Nobles were at the forefront of the development of this grade and have developed practices to generate the additional strength required whilst retaining suitable material ductility for lifting applications.

Rigging Screw Grades

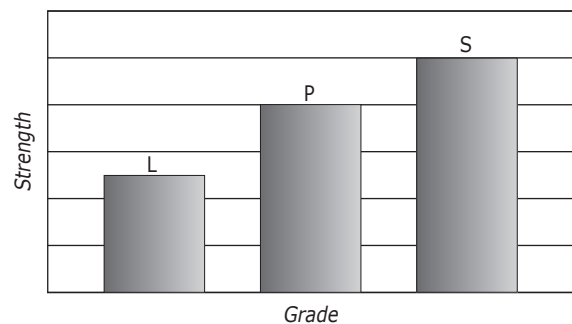

Grade S

Grade S is a grade of rigging screw that is higher in capacity than Grade P and normally requires the use of alloy steels in manufacture to generate material strengths akin to those of Grade 8.8 bolts. Some components are made and stocked in this grade but it is usually reserved for special purpose applications where Grade P is not viable.

Other Grades

Nobles have successfully manufactured rigging screws in special grades such as stainless steels, bronzes etc. These rigging screw materials differ widely in properties and our engineering expertise is used in assigning appropriate load ratings and sizing of componentry.

Load Rating

Rigging screws in accordance with Australian Standards have a factor of safety of 6:1. This relatively high factor is an important safety feature. The safety factor helps to counter possible problems from shock, vibration, fatigue, wear, damage and corrosion. It is important that the safety factor be maintained.

When using a rigging screw always check the working load limit (WLL) stamped on the body. If the rigging screw is a custom item, and the WLL has been altered accordingly, then this will be reflected on the body stamping.



WARNING

- Swapping of end fittings between rigging screws and turnbuckles is not recommended. If end fittings must be swapped consult Nobles for advice.
- Exceeding the WLL could result in failure.

Rigging Screw Sizes

Rigging screws can be made in almost any practical size or configuration. The standard end fittings are either elongated eyes or forged jaws.

Standard body types are either turnbuckles or rigging screws up to M33 and rigging screws only from M39 and above.

WLL TONNES

Nominal Size	Grade L	Grade P	Grade S
M10	0.3	0.6	0.8
M12	0.5	1	1.2
M16	0.75	1.6	2
M20	1.25	2.5	3.2
M24	2.5	4	5
M27	3	5	6.3
M30	4	6.3	8
M33	5	8	10
M39	6	10	12
M42	7.5	12	16
M48	10	16	20
M56	15	20/25*	28/32*
M64	20	28/32*	36/40*
M70	-	36	-
M76	-	42	-
M90	-	60	-
M100	-	75	-

* AS 2319:1984 CAPACITY STILL NOBLES STD SUPPLY

NON PREFERRED GRADE OR SIZE,
MAY NOT BE READILY AVAILABLE

Rigging Screw Barrel Sizes

Apart from standard lengths (B) rigging screw barrels can also be made in custom lengths to specific order requirements.

If locknuts are specified these will reduce the available thread on end fittings and increase overall minimum length. If locknuts are required please specify at time of order.

Locking of Threads

Where rigging screws or turnbuckles are to be used in a permanently adjusted position and where a guy is subjected to shock vibration or rope spin it is necessary to prevent the screws from unwinding. Typical methods of locking threads include locknuts, locking plates and wire.

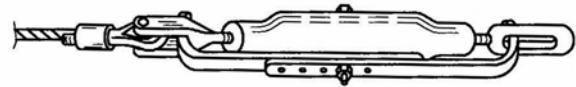

(a) Pair of plates

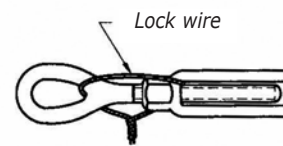

(b) Wire

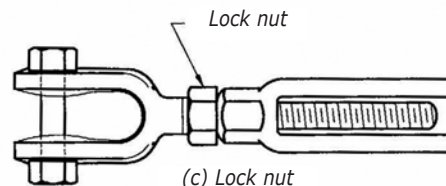

(c) Lock nut

Locknuts

Locknuts are available for each size of rigging screw offered as standard. Nobles rigging screw threads are toleranced such that any standard nut of the correct thread series may be used as a lock nut.



WARNING

- Locknuts may not provide sufficient protection against unwinding where torques are high
- Overtightening Locknuts may cause threads to become overloaded risking accidental failure.
- Never cross drill the load bearing portion of an end fitting thread to enable locking
- Never weld rigging screws or turnbuckles to lock threads
- Lock plates are the most secure locking method and should be used where rope torque is significant.



WARNING

- Regular inspection is required for all rigging screws (including stainless steel ones) to reduce the risk of failure through corrosion
- Failure though corrosion may occur by erosion of the thread within the body being invisible except under close inspection
- Where rigging screw bodies are situated such that water or chemicals can collect within the barrel then the barrel should: be regularly maintained, charged with grease, have it's holes plugged, have drain holes added or a combination of these. Nobles can add drain holes on request.
- Care should be taken that rigging screws fitted in line with dissimilar metals are not at risk from accelerated corrosion

Nobles Alloy Eye Hooks

The Nobles Alloy Eye Hook is a versatile and traditional shaped eye hook that is expertly forged and heat treated to give maximum strength at a practical size. Alloy eye hooks are particularly well suited for use on wire rope slings and winch ropes. The large eye enables the hook to be held captive in a thimble eye on the end of a wire rope and still provide excellent movement and articulation. All Nobles alloy eye hooks come complete with a spring loaded safety catch.

Nobles alloy eye hooks have a Minimum Breaking Load (MBL) in excess of four times the Working Load Limit (WLL) and are batch destruction tested at manufacture.

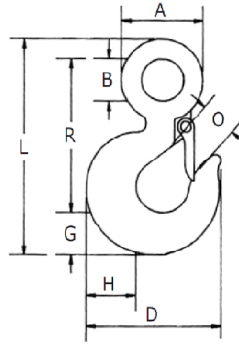

Product Specifications

Name	ITEM #	WLL (tonnes)	A (mm)	O (mm)	D (mm)	H (mm)	G (mm)	L (mm)	R (mm)	B (mm)	Weight (kg)
Alloy Eye Hook Nobles 1t With Latch	11784	1	37	26	26	21	20	109	82	19	0.26
Alloy Eye Hook Nobles 1.5t With Latch	10910	1.5	44	26	74	25	24	124	92	24	0.35
Alloy Eye Hook Nobles 2t With Latch	17927	2	52	30	87	31	36	141	103	28	0.58
Alloy Eye Hook Nobles 3t With Latch	16168	3	62	35	105	35	32	167	121	32	0.8
Alloy Eye Hook Nobles 5t With Latch	17296	5	74	34	122	42	38	200	146	39	1.66
Alloy Eye Hook 7t With Latch	12831	7	97	61	172	59	53	280	210	51	3.26

Uncontrolled version printed 09-Mar-2018 .See www.nobles.com.au for latest up-to-date product information.

Nobles TSF Hooks

The Nobles TSF Swivel Hook is manufactured from quality Crosby forgings by Nobles. The hooks have safety catches attached as standard and are available in capacities from 1.5 to 30 tonne. Every TSF hooks is individually proof load tested to twice the WLL and a NATA test certificate is issued. TSF hooks incorporate a roller thrust bearing to enable the hook to safely rotate under load.

Swivel Hooks For Articulated Cranes

We offer replacement swivel hooks: 10, 12, 15, 16 and 18 tonne TSF designed for compatibility with articulated cranes. These are specially dimensioned to replace the older type fabricated swivels used on these cranes. Please check the dimensions of the existing part before ordering. We can also supply replacement swivels for other type cranes and have been an OEM supplier of swivels to several crane manufacturers.

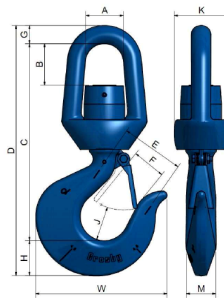

Product Specifications

Name	ITEM #	WLL (tonnes)	A (mm)	B (mm)	C (mm)	D (mm)	E (mm)	G (mm)	H (mm)	J (mm)	K (mm)	M (mm)	W (mm)	Weight (kg)
AS2318 1.5t Nobles TSF Bow & Hook Roller Bearing Swivel Lifting Hook	25476	1.5	44	30	161	205	51	16	29	30	38	24	102	1.5
AS2318 3.0t Nobles TSF Bow & Hook Roller Bearing Swivel Lifting Hook	25312	3	57	41	214	273	64	22	37	39	54	29	123	3.5
AS2318 6.0t Nobles TSF Bow & Hook Roller Bearing Swivel Lifting Hook	25497	6	79	77	268	346	76	32	46	49	79	37	160	7
AS2318 10.0t Nobles TSF Bow & Hook Roller Bearing Swivel Lifting Hook	25308	10	104	107	360	459	101	38	58	63	104	41	192	14.5
AS2318 10.0t Nobles TSF Bow & Hook Roller Bearing Swivel Articulated Crane Hook	25417	10	70	145	394	500	101	40	58	63	100	41	192	15
AS2318 12.5t Nobles TSF Bow & Hook Roller Bearing Swivel Lifting Hook	25232	12.5	104	100	377	481	101	38	66	66	96	49	212	16.5
AS2318 12.0t Nobles TSF Bow & Hook Roller Bearing Swivel Articulated Crane Hook	25545	12	70	128	403	509	101	40	66	66	100	49	212	19
AS2318 17t Nobles TSF Bow & Hook Roller Bearing Swivel Articulated Crane Hook	25600	16	70	124	453	570	127	40	77	72	100	61	263	25
AS2318 16.0t Nobles TSF Bow & Hook Roller Bearing Swivel Lifting Hook	25263	16	98	124	465	591	127	48	77	72	140	61	263	34.5
AS2318 20.0t Nobles TSF Bow & Hook Roller Bearing Swivel Articulated Crane Hook	25469	20	98	149	484	608	127	40	77	72	140	61	263	36
AS2318 20.0t Nobles TSF Bow & Hook Roller Bearing Swivel Lifting Hook	25357	20	98	139	466	609	127	48	77	72	140	61	263	37
AS2318 25.0t Nobles TSF Bow & Hook Roller Bearing Swivel Lifting Hook	25349	25	98	109	518	658	165	48	92	88	140	76	346	48
AS2318 32.0t Nobles TSF Bow & Hook Roller Bearing Swivel Lifting Hook	25480	32	98	111	599	764	175	48	116	99	140	76	357	68

Uncontrolled version printed 09-Mar-2018 . See www.nobles.com.au for latest up-to-date product information.

TSF SWIVELS

GENERAL CAUTIONS

Ratings or Working Load Limits (WLL) shown in Nobles literature and stamped onto swivels apply only to new or as new condition products. The working load limit can be affected by intentional alterations, damage, corrosion, misuse and special conditions of use. Always have your swivels regularly inspected by a competent person who may suggest repairs or condemn your swivels should anything such as the above be deleterious to the WLL.

Shock loading can greatly increase the actual loads placed on a swivel. Extraordinary conditions such as shock loading must be taken into account when selecting products for use in swivel systems.

The WLL which applies for any Nobles swivel is only for the use of the swivel as a lifting swivel under slow pivoting type rotation. The WLL applies only for pure axial loading.

Swivels must always be correctly selected and fitted for every lift. Attention must be paid to the balance and security of the load.

Never weld any part of a swivel without consulting the manufacturer. Special steels are commonly used and special welding procedures and precautions may be necessary.

IMPORTANT

For maximum safety and efficiency, swivel lifting systems must be properly designed, used and maintained. You must understand the use of swivels in a lifting system. These instructions, and the standards to which they refer may use technical words and detailed explanations. **IF YOU DO NOT UNDERSTAND ALL WORDS AND DIAGRAMS - DO NOT MAKE ASSUMPTIONS AND GUESSES AND DO NOT USE A LIFTING SWIVEL.** For further assistance and training support contact your nearest Nobles branch.

SWIVELLING UNDER LOAD

Nobles swivels are primarily designed for lifting tasks. As such our swivels are suited to the speeds and duty cycles associated with lifting where rotations are slow, intermittent and often induced by hand.



WARNING

- Nobles swivels should not be used on the end of equipment applying powered rotation such as drilling and boring machines. Where such an activity is anticipated please seek the advice of Nobles' engineering department.
- Use of swivels in towing applications may cause sudden rotation or high rotation speeds that may damage a lifting swivel

SAFE LIFTING

Please refer to the further advice overleaf and heed the cautions below.



WARNING

- Improper use of this product could result in death or serious injury.
- Never exceed the working load limit.
- Apply only axial loads to the swivel.
- Never hoist loads over or near people.
- Always operate, inspect and maintain this equipment in accordance with relevant safety standards.
- Always check the security of the swivel nut.
- If you are ever in doubt how to safely use this product contact your Nobles branch for advice - Don't Guess!
- Swivels must be subject to proof load testing in accordance with AS2318-1990 prior to being put into service or after any repair. Testing must be in accordance with our procedure to protect the bearing fitted. Please seek our advice before proof testing.
- Always ensure that the load is properly supported by the hook. Never support loads by the hook tip or latch.

TSF SIZES

In order to standardise some of the larger TSF swivel hooks and to better satisfy the needs of customers, the TSF range has been revised.

TSF hooks all incorporate a proper roller thrust bearing so as to be able to safely rotate loads. This facility makes the Nobles TSF hook a simple way of adding rotation under load capability to a lifting system.

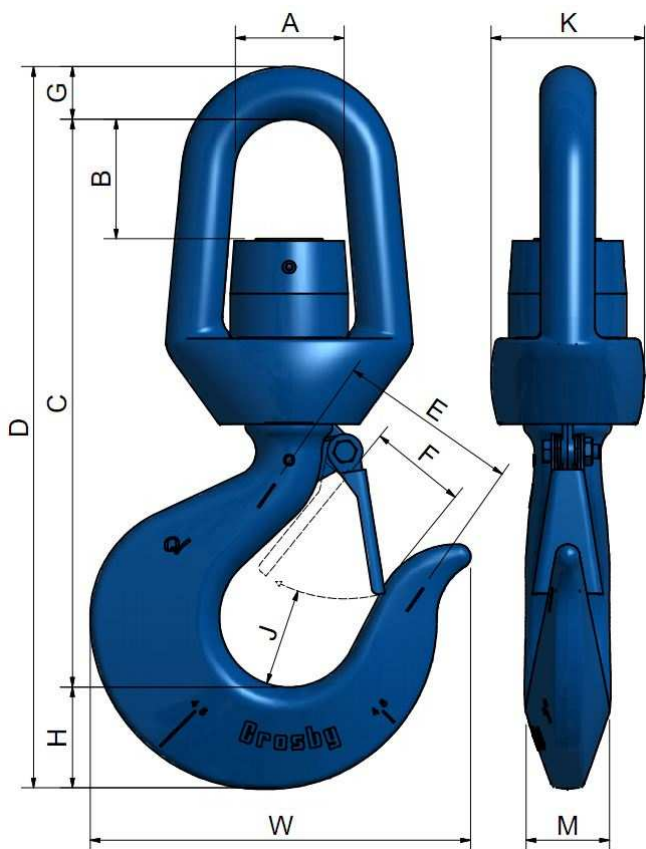

WARNING

- Regularly inspect your hook for signs of wear. Original as forged dimensions are provided for reference.
- Inspections shall be carried out by a competent person who may condemn or recommend repairs to a swivel based on condition of the swivel and the data below.
- The deformation indicators are a pair of raised lines forged into the hook for enduring reference to check for hook deformation (opening out).
- The Angle Indicators are a pair of raised lines forged into the hook for enduring reference and show the maximum included angle which is allowed between two (2) slings in the hook.

SPECIAL APPLICATIONS

Properly cared for, a Nobles TSF swivel will give reliable service for many lifts in a general purpose environment.

Nobles can supply TSF type swivels to comply with special surface treatment, certification & design requirements. Please discuss your special requirements with us.

	WLL (tonnes)	A (mm)	B (mm)	C (mm)	D (mm)	DEFORMATION INDICATOR E (mm)	G (mm)	H (mm)	J (mm)	K (mm)	M (mm)	W (mm)	CROSBY ALLOY HOOK CODE	ASS'Y TARE (kg)
STANDARD TYPE														
NJTSF015	1.5	44	30	161	205	50.8	16	29.0	29.5	38.1	23.9	102	H	1.5
NJTSF03	3	57	54	214	273	63.5	22	36.6	38.9	54.0	28.7	123	I	3.5
NJTSF06	6	79	77	268	346	76.2	32	46.2	49.3	79.0	36.6	160	J	7
NJTSF10	10	104	107	360	459	101	38	57.5	62.5	104	41.4	192	K	14.5
NJTSF125	12.5	104	100	377	481	101	38	66	66	95.5	49.3	212	L	16.5
NJTSF160	16	98	124	465	591	127	48	76.5	71.5	140	60.5	263	N	34.5
NJTSF200	20	98	139	466	609	127	48	76.5	71.5	140	60.5	263	N	37
NJTSF250	25	98	109	518	658	165	48	92	87.5	140	76	346	O	48
NJTSF300	32	98	111	599	764	175	48	116	98.5	140	76	357	P	68
ARTICULATED CRANE TYPE (FRANNA)														
NJTSF100F	10	70	145	394	500	101	40	57.5	62.5	100	41.4	192	K	15
NJTSF120F	12	70	128	403	509	101	40	66	66	100	49.3	212	L	19
NJTSF160F	16	70	124	453	570	127	40	76.5	71.5	100	60.5	263	N	25
NJTSF200F	20	98	149	484	608	127	48	76.5	71.5	140	60.5	263	N	36

TSF style hooks are regularly produced in other sizes to suit particular applications and can be produced in custom configurations when required.

Nobles Safety Handle Hooks

Nobles Safety Handle Hooks are commonly used on the end of a crane pendant/stinger wire rope assembly. These hooks are used extensively in onshore and offshore lifting applications.

The safety handle enables an operator to safely open and close the hooks while keeping hands and gloves well clear of the closing mechanism. The safety handle also makes it easy to guide the open hook onto the load ring or attachment point.

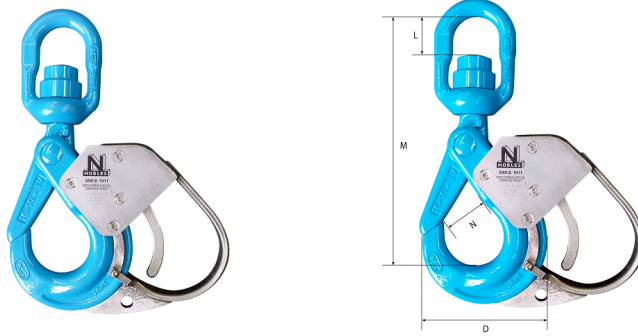

Product Specifications

Name	ITEM #	Size (mm)	WLL (tonnes)	D (mm)	L (mm)	M (mm)	N (mm)	Weight (kg)
Hook With Handle Swivel Self-Locking 20mm Gr100	11704	20	16	200	82	408	70	12.5
Hook With Handle Swivel Self-Locking 16mm Gr100	13631	16	10	168	50	330	60	9.75

Uncontrolled version printed 09-Mar-2018 .See www.nobles.com.au for latest up-to-date product information.

Crosby Shank Hooks

Crosby alloy shank hooks are available up to 300 tonne capacity and are expertly designed and manufactured with careful forging and precision quenching and tempering to ensure maximum capacity without excessive weight and bulk.

Crosby hooks feature a pre-drilled cam which can be equipped with a safety catch and the Crosby QUIC-CHECK deformation indicators. The QUIC-CHECK indicators allow a measurement to be taken to determine if the throat opening has changed thus indicating an overload.

Angle indicators are also included on Crosby hooks to ensure maximum included sling angles are not exceeded and to assist in approximating other sling angles.



Product Specifications

Name	ITEM #	Model	Hook Code	WLL (tonnes)	Weight (kg)
Size D A Alloy 1.0t Crosby S-319N Std. Length Shank Hook Forging Blank C/W Catch	25415	S-319N	D	1.25	0.23
Size J A Alloy 7.0t Crosby S-319N Std. Length Shank Hook Forging Blank C/W Catch	25482	S-319N	J	8	3.29
Size K A Alloy 11.0t Crosby S-319N Std. Length Shank Hook Forging Blank C/W Catch	25524	S-319N	K	11.5	6.12
Size L A Alloy 15.0t Crosby S-319N Std. Length Shank Hook Forging Blank C/W Catch	25322	S-319N	L	16	9.9
Size N A Alloy 22.0t Crosby S-319N Std. Length Shank Hook Forging Blank C/W Catch	25506	S-319N	N	22	17.4
Size O A Alloy 30.0t Crosby S-319N Std. Length Shank Hook Forging Blank C/W Catch	25484	S-319N	O	30	32.7
Size P A Alloy 37t Crosby S-319N Long Length Shank Hook Forging Blank C/W Catch	27544	S-319N	P	37	61

Uncontrolled version printed 09-Mar-2018 .See www.nobles.com.au for latest up-to-date product information.

Crosby® Shank Hooks



- Hoist hooks incorporate markings forged into the product which address two (2) QUIC-CHECK® features.
 - **Deformation Indicators** -- Two strategically placed marks, one just below the shank or eye and the other on the hook tip, which allows for a **QUIC-CHECK®** measurement to determine if the throat opening has changed, thus indicating abuse or overload. To check, use a measuring device (i.e. tape measure) to measure the distance between the marks. The marks should align to either an inch or half-inch increment on the measuring device. If the measurement does not meet this criteria, the hook should be inspected further for possible damage.
 - **Angle Indicators** -- Indicates the maximum included angle which is allowed between two (2) sling legs in the hook. These indicators also provide the opportunity to approximate other included angles between two sling legs.
- Chemical analysis and tensile tests performed on each PIC to verify chemistry and mechanical properties.

S-319/S-319N
 Trademark indicates
 QUIC-CHECK® product.
 Hook Material
 Codes: A-Alloy Steel,
 B-Bronze High Strength,
 C-Carbon Steel.



SEE APPLICATION AND WARNING INFORMATION
 Crosby On Pages 142 - 143
 McKissick On Pages 144-145
 Para Español: www.thecrosbygroup.com

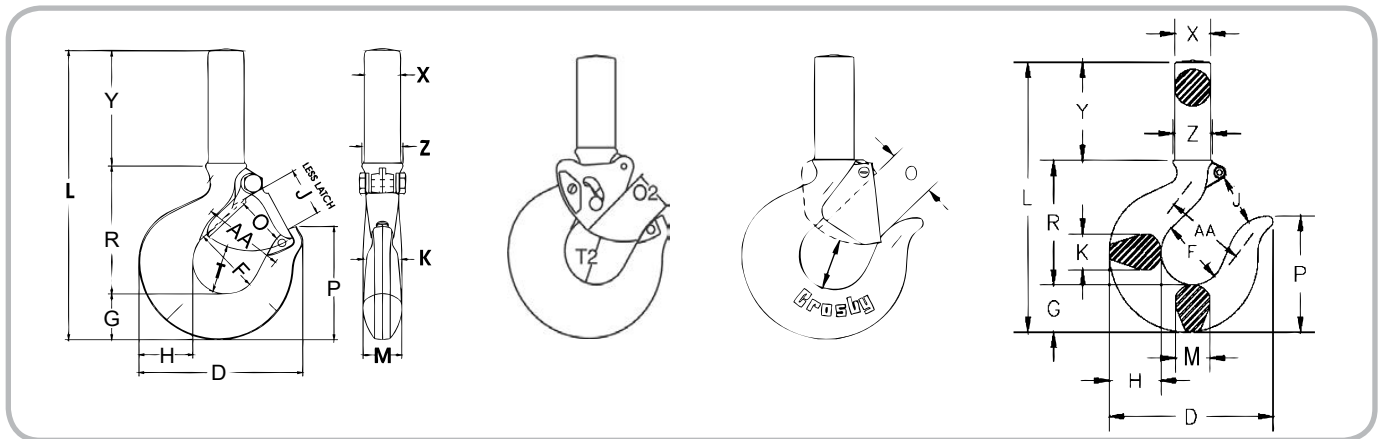

S-319 / S-319N Crosby® Shank Hook

Hook ID Code	Dimensions (in.)																	
	D	F	G	H	J	K	L	M	O	O2 ††	P	R	T	T2 ††	X	Y	Z	AA**
D	2.86	1.25	.73	.81	.93	.63	5.14	.63	.93 †	-	1.96	2.35	.97	-	.59	2.06	.69	1.50
F	3.16	1.38	.84	.94	.97	.71	5.68	.71	.97 †	-	2.22	2.59	.97	-	.66	2.25	.78	2.00
G	3.59	1.50	1.00	1.16	1.06	.88	6.35	.88	1.06 †	-	2.44	2.76	1.03	-	.72	2.59	.88	2.00
H	4.00	1.62	1.14	1.31	1.19	.94	7.14	.94	1.16 †	-	2.78	3.16	1.16	-	.88	2.84	1.00	2.00
I	4.84	2.00	1.44	1.63	1.50	1.31	8.63	1.13	1.36 †	1.00	3.47	3.85	1.53	1.50	1.16	3.44	1.25	2.50
J	6.28	2.50	1.82	2.06	1.78	1.66	10.43	1.44	1.61 †	1.31	4.59	4.77	1.96	1.88	1.41	3.84	1.56	3.00
K	7.54	3.00	2.26	2.63	2.41	1.88	12.52	1.63	2.08 †	1.81	5.25	5.88	2.47	2.25	1.81	4.38	1.94	4.00
L	8.34	3.25	2.60	2.94	2.62	2.19	16.10	1.94	2.27 †	2.00	5.96	6.37	2.62	2.31	2.00	7.00	2.19	4.00
N	10.34	4.25	3.01	3.50	3.41	2.69	18.15	2.38	3.02 †	2.75	6.88	8.14	2.83	2.56	2.56	7.00	2.63	5.00
O	13.62	5.00	3.62	4.62	4.00	3.00	23.09	3.00	3.25	-	8.78	9.44	3.44	-	3.12	10.00	3.12	6.50
O	13.62	5.00	3.62	4.62	4.00	3.00	31.09	3.00	3.25	-	8.78	9.44	3.44	-	3.12	18.00	3.12	6.50
P	14.06	5.38	4.56	5.00	4.25	3.62	32.12	3.00	3.00	-	11.31	12.50	3.88	-	4.00	15.00	4.00	7.00
P	14.06	5.38	4.56	5.00	4.25	3.62	41.12	3.00	3.00	-	11.31	12.50	3.88	-	4.00	24.00	4.00	7.00
S	15.44	6.00	5.06	5.50	4.75	3.72	34.12	3.25	3.38	-	12.56	14.00	4.75	-	4.19	15.00	4.19	8.00
S	15.44	6.00	5.06	5.50	4.75	3.72	43.12	3.25	3.38	-	12.56	14.00	4.75	-	4.19	24.00	4.19	8.00
T	18.50	7.00	6.00	6.50	5.75	4.44	36.06	3.91	4.12	-	14.75	15.56	5.69	-	4.50	14.50	4.50	10.00
T	18.50	7.00	6.00	6.50	5.75	4.44	47.56	3.91	4.12	-	14.75	15.56	5.69	-	4.50	26.00	4.50	10.00
U	20.62	7.75	6.69	7.25	6.50	5.25	41.16	4.25	4.88	-	16.53	19.38	6.00	-	5.00	15.00	5.00	11.50
U	20.62	7.75	6.69	7.25	6.50	5.25	49.16	4.25	4.88	-	16.53	19.38	6.00	-	5.00	23.00	5.00	11.50
W	23.00	6.81	8.59	9.88	5.88	5.50	42.12	5.50	4.50	-	17.25	18.41	7.00	-	7.00	15.00	7.00	12.00
W	23.00	6.81	8.59	9.88	5.88	5.50	48.12	5.50	4.50	-	17.25	18.41	7.00	-	7.00	21.00	7.00	12.00
X	24.38	6.75	9.12	10.94	6.00	6.00	45.75	6.00	4.50	-	18.00	18.38	7.00	-	7.25	18.00	7.25	13.00
Y	26.69	7.50	9.75	11.81	6.60	7.00	50.50	7.00	5.00	-	19.75	20.50	8.00	-	8.00	20.00	8.00	13.00
Z	30.12	9.50	10.62	12.94	8.00	7.25	54.69	8.00	6.25	-	22.69	23.50	8.25	-	9.50	20.00	9.50	15.00

Rough as-forged dimension. Shank will not machine to this dimension. Please refer to page 147 for recommended shank diameter when machining. ** Deformation Indicator. † 3/4C - 22A dimensions shown are for S-4320 Latch Kits. Dimensions for sizes 20 ton carbon and larger are for PL Latch Kits. †† Dimensions are for PL-N latch kits. For the purpose of calculating D/d ratio, utilize dimension M.

General

There are numerous hook designs and configurations to suit many different applications. It is important to select the right hook for the job. Nobles sales staff can advise on the most suitable hook types for any given application.



WARNING

- All hooks should be safety hooks i.e. have a safety catch.
- Hooks without safety catches are not recommended.

Inspection Before Use

The pre-use check for hooks should cover the following:

1. The WLL should be clearly marked.
2. The safety catch should be in place and functioning correctly.
3. The hook should be checked for any distortion, cracking and excessive wear or corrosion.
NOTE: The wear on the bearing surface of the hook should not exceed 8% of the nominal dimension.
4. Check that the opening of the hook is within the manufacturers parameters. If the hook is opened excessively it is a sign that it has been point loaded or overloaded.
5. Moving parts such as release cams should be checked for free movement.
6. If the hook is a ball bearing swivel hook check that the hook is swivelling freely and that the bearing is not making any unusual noises. Unusual noises are often a sign of bearing fatigue or bearing failure.
7. If the hook has a threaded machined shank ensure that the thread is in good order and that the nut is turning freely on the thread.

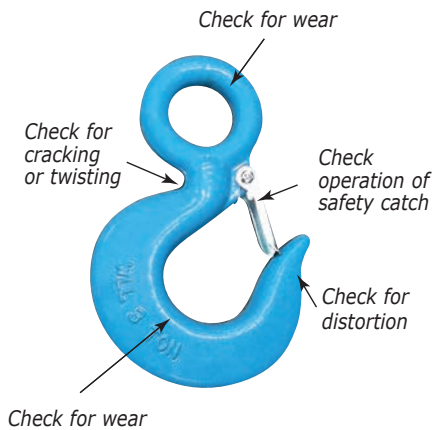

WARNING

- Loads may disengage from hooks if proper procedures are not followed.
- Falling loads may cause property damage, serious injury or death.
- Threads may corrode and/or strip and drop the load.
- The hooks must always support the load. The load must never be supported by the safety catch.
- Never apply more force than the hook's WLL.
- Read and understand the manufacturers instructions before using the hook.

Marking

All hooks designed and tested in accordance with Australian Standards shall include:

- Manufacturer's identification.
- Quality grade.
- SWL or WLL.
- Identification marking or batch number to trace the hook to the manufacturers test certificate.

Care In Use

1. For hooks used in frequent load cycles or pulsating loads, the hook and threads should periodically be inspected by Magnetic Particle or Dye Penetrant. (Note: Some disassembly may be required.)
2. Never use a hook if its throat opening has been increased, or its tip has been bent more than 10 degrees out of plane from the hook body, or is in any other way distorted or bent. Note: A safety catch will not work properly on a hook with a bent or worn tip.
3. Never use a hook that is worn beyond a recommended maximum of 8%.
4. Remove from service any hook with a crack, nick, or gouge. Hooks with cracks, nicks, or gouges shall be repaired by carefully grinding lengthwise, following the contour of the hook, provided that the reduced dimension is within the 8% wear limit.
5. Never repair, alter, rework, or reshape a hook by welding, heating, burning or bending.
6. Never side load, back load, or tip load a hook.
7. Eye hooks, shank hooks and swivel hooks are designed to be used with wire rope or chain. Efficiency of an assembly may be reduced when used with synthetic material.
8. Always make sure the hook supports the load. The catch must never support the load.
9. When placing two sling legs in a hook, make sure the angle from the vertical to the outermost leg is not greater than 45 degrees, and the included angle between the legs does not exceed 90 degrees.
10. The WLL of a hook applies only when the load is correctly positioned on the load line of the hook. If the hook is eccentrically loaded, or the load is applied other than on the load line, the WLL is greatly reduced.
11. Always use a swivel hook, or insert a swivel link between the load hook and the lifting rope, when the load has a tendency to rotate when lifted.
12. Always check to ensure that the hook safety catch has closed correctly before allowing the load to be lifted.

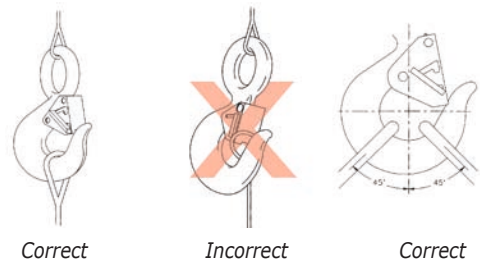
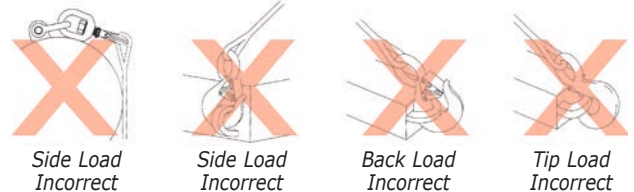

Concrete Lifting Clutches

SwiftLift Concrete Lifting Clutches have been exclusively designed and approved for use with Reid SwiftLift Anchors.

They are available in a range of Working Load Limits.

They have been designed so that they cannot spontaneously disengage whilst the system is under load at any orientation, provided they are connected to the head of the correct anchor in the recess. When the lift is complete and the load released, the clutch is quickly and simply disengaged.

Identification markings are required for the SwiftLift™ Lifting Eye to comply with AS 3850 – 2003.

The SwiftLift™ Lifting Eye must be proof load tested every 12 months in accordance with AS 3850–2003.

The SwiftLift™ Lifting Eye has a FOS (factor of safety) of no less than 5 in accordance with AS 3850 – 2003.



Product Specifications

Name	ITEM #	WLL (tonnes)	Weight (kg)
Concrete Lifting Clutch Swiftlift 1.3t	15559	1.3	0.9
Concrete Lifting Clutch Swiftlift 2.5t	14488	2.5	1.3
Concrete Lifting Clutch Swiftlift 5t	17268	5	3.2
Concrete Lifting Clutch Swiftlift 7t	12246	7	7.3
Concrete Lifting Clutch Swiftlift 10t	15724	10	10
Concrete Lifting Clutch Swiftlift 20t	13239	20	20.4

Uncontrolled version printed 09-Mar-2018 .See www.nobles.com.au for latest up-to-date product information.

Rigging

OPERATION - SwiftLift™ Clutches

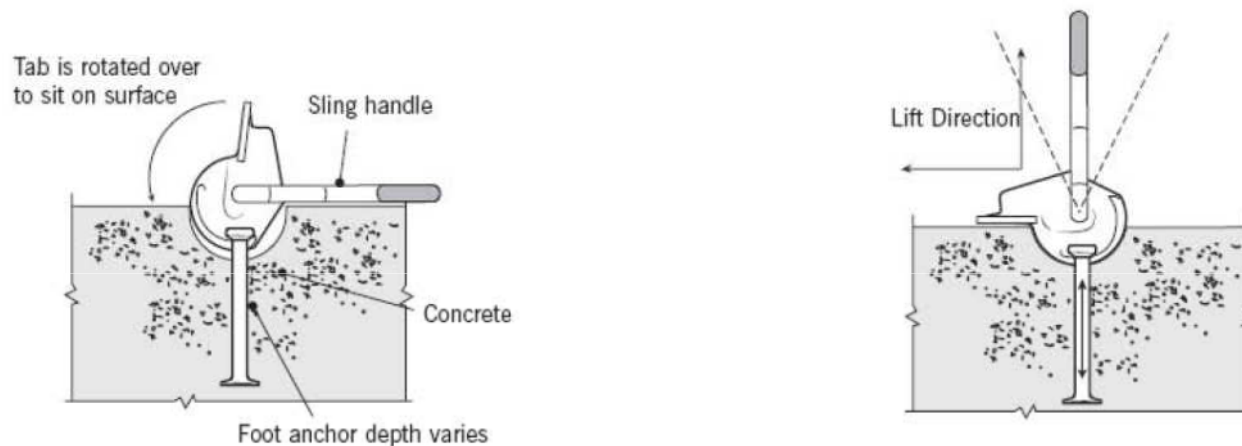

1. SwiftLift Clutch is attached to the SwiftLift anchor by;
 - lowering the clutch slot over the anchor
 - then rotation the clutch tab until it rests on the concrete surface
2. As the load is raised, the anchor takes the full load of tension

Rigging

OPERATION - SwiftLift™ Clutches

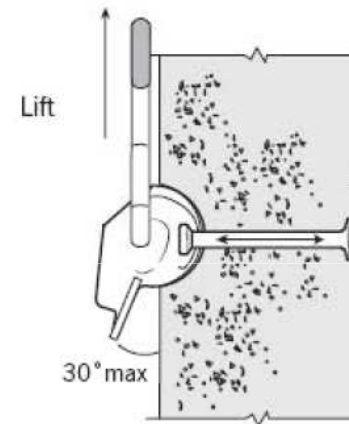
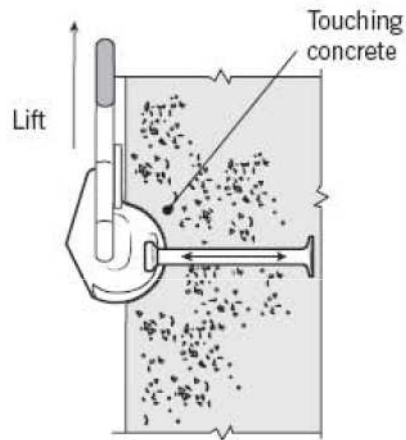

3. As the panel rotates to the vertical position, the clutch comes in contact with the concrete surface;
 - this transfers the lifting force into the concrete
 - the anchor prevents the clutch from slipping out of the void
4. Lifting away from the tab is also safe provided the tab does not rise more than 30° from the concrete surface

Rigging

Check for wear and tare - SwiftLift™ Clutches

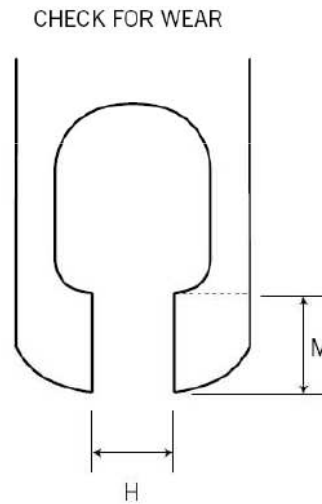
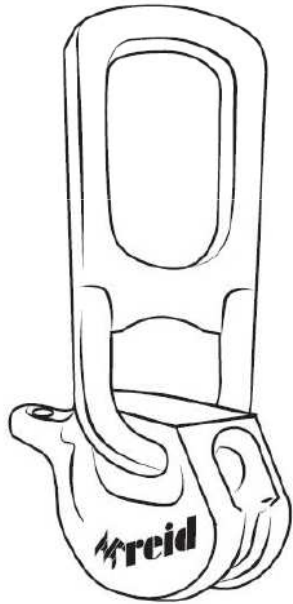

Size	H max (mm)	H min (mm)
1.3	13	5.5
2.5	18	5.5
5.0	25	8.0
10.0	32	12.0
20.0	46	18.0
32.0	58	24.0

Rigging

Effective Rigging



Using a triangular spreader beam with shackles and two sets of chains will ensure legs are equally loaded.



Using a spreader beam with two sets of chains will ensure the legs are equally loaded.

Rigging

Effect of sling angle

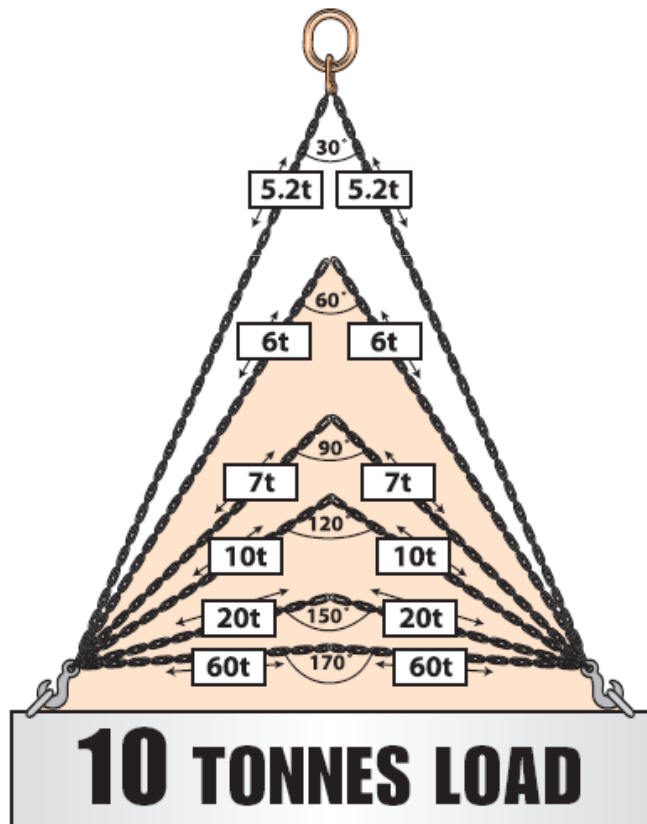

1. The longer the slings. The lower the load on the anchors.
 - For example, at an angle of 170° the load on each sling is six times the weight of the actual load being lifted
2. Never make sling length shorter than the distance between two anchors.
3. Never set the sling up with a greater angle than 60°.

Rigging - Configurations

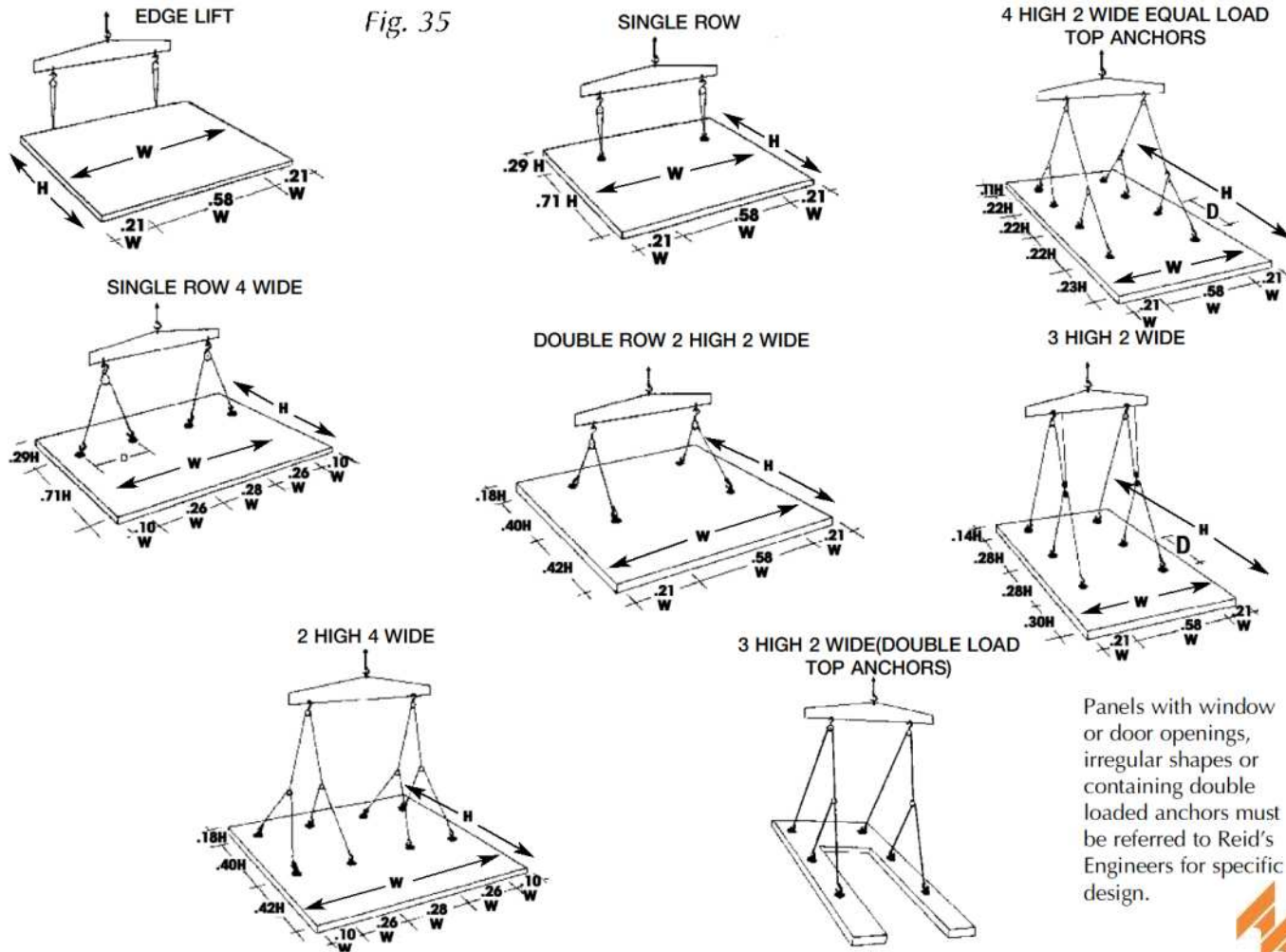



Contact Us



1300 711 559



sales@nobles.com.au