

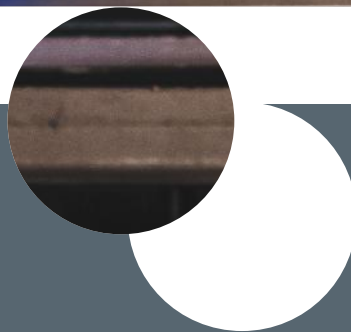

SOLUZIONI PER LA LOGISTICA INDUSTRIALE
SOLUTIONS FOR INDUSTRIAL LOGISTICS



BUTTI

PENSATO PER DURARE



BUTTI

PENSATO PER DURARE

MOVIMENTAZIONE E STOCCAGGIO | HANDLING AND STORAGE

08



STOCCAGGIO FUSTI E CISTERNETTE | DRUMS AND TANKS STORAGE

31



SOLLEVAMENTO | LIFTING

42

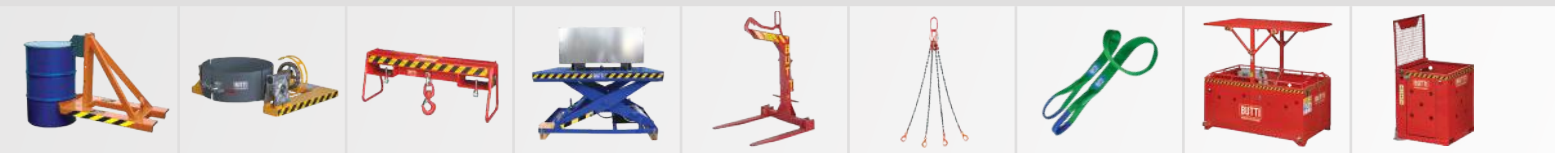

RECYCLING E PULIZIA | RECYCLING AND CLEANING

51



ACCESSORI | ACCESSORIES

56

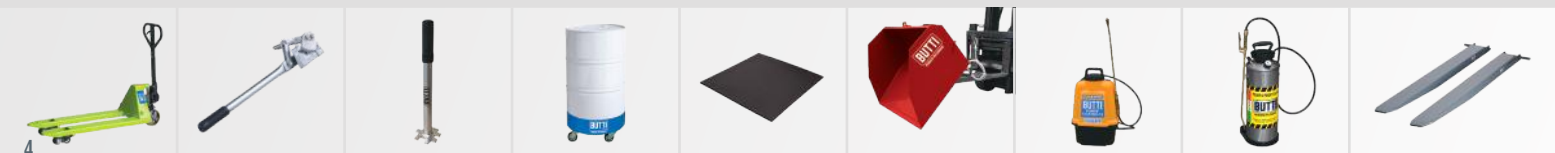

- 10 CONTENITORI RIBALTABILI "PERTUTTO" | *TIPPING CONTAINERS "PERTUTTO"*
- 14 CARRELLI PORTA BARRE "CARGO" E TRAINATORE ELETTRICO | *"CARGO" BAR CARTS AND VERTICAL ELECTRIC TUG*
- 15 CAVALLETTI INDUSTRIALI "BIG WORKS" | *INDUSTRIAL TRESTLES "BIG WORKS"*
- 16 SCAFFALATURE INDUSTRIALI E BARELLE DI STOCCAGGIO | *INDUSTRIAL SHELVINGS AND STORAGE STRETCHERS*
- 17 CONTENITORI A FONDO APRIBILE "COMPACT" | *CONTAINERS WITH OPENABLE BOTTOM "COMPACT"*
- 18 CONTENITORI IN METALLO | *METAL CONTAINERS*
- 21 CONTENITORI IN POLIETILENE E IN RETE | *POLYETHYLENE AND MESH CONTAINERS*
- 22 DEPOSITI E PALLETS PER BOMBOLE | *STORAGE CONTAINERS AND PALLETS FOR GAS CYLINDERS*
- 23 ARMADI DI SICUREZZA | *SAFETY CABINETS*
- 24 PORTA ATTREZZI | *TOOLS HOLDER*
- 27 TRAMOGGIA PORTA "BIG-BAG" | *"BIG-BAG" HOPPER*
- 28 PORTA "BIG-BAG" | *"BIG-BAG" CONTAINER*
- 30 CARRELLI | *CARTS*

- 32 VASCHE DI CONTENIMENTO PER FUSTI | *SPILL CONTAINMENT PALLETS FOR DRUMS*
- 34 VASCHE DI CONTENIMENTO PER CISTERNETTE | *SPILL CONTAINMENT PALLETS FOR TANKS*
- 36 VASCHE DI CONTENIMENTO PER SCAFFALATURE | *SPILL CONTAINMENT PALLETS FOR SHELVINGS*
- 36 FUSTI E CISTERNE | *DRUMS AND TANKS*
- 37 VASCHE DI CONTENIMENTO IN POLIETILENE | *POLYETHYLENE SPILL CONTAINMENT PALLETS*
- 38 SUPPORTI PER FUSTI CON VASCHE DI CONTENIMENTO | *DRUMS SUPPORTS WITH SPILL CONTAINMENT PALLET*
- 39 DEPOSITI PER ESTERNI | *OUTDOOR CONTAINERS*
- 40 SCAFFALATURE ANTISISMICHE CON VASCA DI CONTENIMENTO | *ANTI-SEISMIC SHELVINGS WITH SPILL CONTAINMENT PALLET*

- 42 PINZE E RIBALATORI PER FUSTI | *GRIPPERS AND DUMPERS FOR DRUMS*
- 43 PINZE A BECCO PER FUSTI | *FLAT NOSE GRIPPERS FOR DRUMS*
- 44 GANCI DI CARICO PER CARRELLI ELEVATORI | *LIFTING HOOKS FOR FORKLIFT*
- 44 TAVOLA ELEVATRICE | *LIFTING TABLE*
- 45 FORCHE GRUCAR E COPPIA DI TRAVERSE PER IL SOLLEVAMENTO | *GRUCAR CRANE FORKS AND PAIR OF CROSSBEAMS FOR LIFTING*
- 46 IMBRAGHI A CATENA | *HARNESS CHAINS & ONE LEG SLINGS*
- 47 BRACHE IN POLIESTERE E CRICCHETTI | *POLYESTER FLAT WEBBING SLINGS AND RATCHET STRAP*
- 48 CESTONI SOLLEVABILI | *LIFTING MAN BASKETS*
- 50 CONTENITORE PER MANUTENZIONE AEREA | *BASKET FOR AERIAL MAINTENANCE*

- 51 SCOPE INDUSTRIALI E MAGNETICHE | *INDUSTRIAL AND MAGNETIC BROOMS*
- 52 VASCHE DI LAVAGGIO | *WASHING TANKS*
- 53 ROLL CONTAINER PER CARTONE | *ROLL CONTAINER FOR PAPERBOARD*
- 53 CONTENITORE PER BATTERIE ESAUSTE | *CONTAINER FOR EXHAUSTED BATTERIES*
- 54 KIT PRONTO INTERVENTO CARRELLATO | *FIRST REACTION KIT WITH WHEELS*
- 54 BIDONI CARRELLATI | *WHEELED BINS*
- 54 ASSORBENTI | *ABSORBENTS*
- 55 SPAZZANEVE, SPARGISALE, FRESANEVE | *SNOWPLOUGH, SALT SPREADER, SNOW BLOWER*

- 56 TRANSPALLET BIRULLO | *DUAL ROLLER TRANSPALLET*
- 56 TAGLIAFUSTI | *DRUMS DEHEADER*
- 56 CHIAVE PER FUSTI | *KEY FOR DRUMS*
- 56 BASE CIRCOLARE PER FUSTO | *ROUND BASE FOR DRUM*
- 56 TAPPETO ANTI TRAUMA | *ANTI-SHOCK MAT*
- 57 POMPE A PRESSIONE | *PRESSION SPRAYERS*
- 57 BENNA SABBIA | *SAND BUCKET*
- 57 ACCESSORI DI SICUREZZA PER IL LAVORATORE | *ACCESSORIES FOR WORKER SAFETY*
- 58 PROLUNGHE PER FORCHE | *FORK EXTENSIONS*

BUTTI

PROGETTIAMO CON ESPERIENZA, COSTRUIAMO CON PROFESSIONALITÀ

Progettiamo e realizziamo attrezzature per movimentare e contenere ogni tipo di materiale, rendendo più veloce e sicuro il lavoro in vari settori.

Possiamo proporre le soluzioni innovative che ci differenziano perché non ci siamo mai accontentati di limitarci a "produrre", ma abbiamo sempre dato grande importanza alla fase di progetto.

Il nostro catalogo non offre solo i prodotti che il mercato richiede, ma punta soprattutto a proporre soluzioni ad esigenze che ancora non hanno una risposta: la nostra forza è la continua innovazione, la costante ricerca di qualità, la grande flessibilità tecnica e commerciale che ci pone come interlocutore privilegiato per le aziende che cercano soluzioni efficaci ed immediate.



WE DESIGN WITH EXPERIENCE, WE BUILD WITH PROFESSIONALISM

We design and manufacture equipment to handle and contain all types of materials, making work faster and safer in various sectors.

We can propose innovative solutions that differentiate us because we have never contented ourselves with merely "producing", but we have always given great importance to the project phase.

Our catalogue does not only offer the products that the market requires, but aims above all to offer solutions to needs that do not have an answer yet: our strength is the continuous innovation, the constant research for quality, the great technical and commercial flexibility that makes us a privileged interlocutor for companies looking for effective and immediate solutions.

I NOSTRI CONTATTI | OUR CONTACTS:

Via Mayer 13 - 24034 Cisano Bergamasco (BG) - Italy | Tel. +39 035 787300 - +39 035 787005 - Fax +39 035 787322 | butti@butti.it - www.butti.it



30 ANNI DI ESPERIENZA

MODERNO STABILIMENTO SU UN'AREA DI 10.000 METRI QUADRI

REPARTO INTERNO RICERCA E SVILUPPO

MAGAZZINO CON PRODOTTI IN PRONTA CONSEGNA

REPARTO INTERNO LAVORAZIONE E REALIZZAZIONE PRODOTTI FINITI

REPARTO INTERNO MARKETING E COMUNICAZIONE

NORMATIVE DI RIFERIMENTO: D.LGS 81/2008 - EN 14502-1 - EN13155

NB: Le immagini dei prodotti sono puramente indicative e potrebbero pertanto non essere perfettamente rappresentative delle caratteristiche del prodotto.
La BUTTI si riserva la facoltà di modificare in qualsiasi momento e senza alcun preavviso l'esecuzione e le dimensioni dei prodotti illustrati.



DOVE SIAMO | OUR LOCATION:

Ci trovate tra Lecco e Bergamo, facilmente raggiungibili da Monza e Milano | You can find us between Lecco and Bergamo, easily reachable from Monza and Milan

**IL NOSTRO LAVORO
MIGLIORA IL VOSTRO LAVORO**

Le tre linee di prodotto che proponiamo affrontano settori diversi – edilizia, industria, recycling – ma hanno in comune la necessità di strutture solide ed affidabili. La nostra trentennale esperienza ci consente di impostare le linee di produzione assicurando un costante controllo, dal progetto alla finitura. Per questo motivo i nostri prodotti non sono un costo per l'azienda, ma un investimento per migliorare sicurezza e produttività.

**OUR WORK
IMPROVES YOUR WORK**

The three product lines we offer address different sectors - construction, industry, recycling - but they have in common the need of solid and reliable structures. Our thirty years of experience allow us to set up production lines ensuring constant control, from design to finishing. For this reason, our products are not a cost for the company, but an investment to improve safety and productivity.



30 YEARS OF EXPERIENCE

A MODERN PLANT ON AN AREA OF 10,000 SQUARE METERS

INTERNAL RESEARCH AND DEVELOPMENT DEPARTMENT

WAREHOUSE WITH PRODUCTS READY ON STOCK

INTERNAL DEPARTMENT FOR PROCESSING AND CONSTRUCTION OF FINISHED PRODUCTS

INTERNAL MARKETING AND COMMUNICATION DEPARTMENT

REFERENCE REGULATIONS: D.LGS 81/2008 - EN 14502-1 – EN13155



NB: The product pictures are purely indicative and may not exactly represent the product features. BUTTI reserves the right to modify, at any time and without notice, the execution and the sizes of the products shown.



LAVORARE IN SICUREZZA | WORK SAFELY



CILINDRO IDRAULICO HYDRAULIC CYLINDER "SECURE SYSTEM"

Dalla continua ricerca per la sicurezza negli ambienti di lavoro la Butti ha ideato il nuovo sistema "SECURE SYSTEM": cilindro idraulico, applicato a richiesta sui contenitori ribaltabili "Pertutto" per una maggiore sicurezza. Garantisce lunga vita ai cuscinetti dei montanti del carrello elevatore ed ai contenitori stessi, permettendo un ribaltamento graduale e progressivo senza violenti contraccolpi o cadute accidentali. Il cilindro "Secure System" è montato nella parte sottostante del contenitore; la sua installazione non comporta ingombro nelle dimensioni.

From the ongoing search of safety in workplaces, Butti has devised the new system "SECURE SYSTEM": hydraulic cylinder, which can be applied on request to the tipping containers "Pertutto" to have more safety. It guarantees long lifespan both for forklifts and containers themselves by allowing a gradual and progressive tipping without violent backlashes and accidental falls.

The "Secure System" cylinder is placed at the bottom of the container; its installation doesn't change the container dimensions.

FORNITI DI SERIE CON | STANDARD EQUIPMENT



//////
 Tappo di scarico a vite su
 vasca di decantazione
*Draining screwplug on a
 settling tank*



//////
 Ruote antirumore girevoli
 con freno
*Rotating noiseless wheels
 with brake*

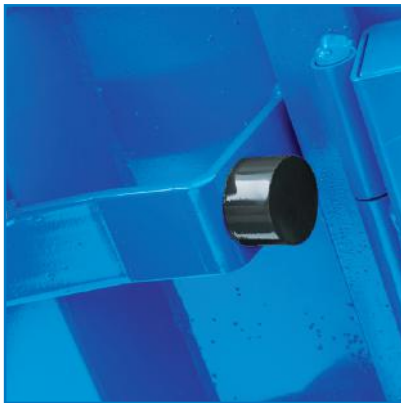

//////
 Tamponi in gomma
Rubber bumpers



//////
 Filtro in lamiera zincata
 su vasca di decantazione
*Galvanized metal sheet
 filter on a settling tank*



//////
 Dispositivo di sgancio
Release device



//////
 Targhetta di
 identificazione
Identification plate



//////
 Mezzaluna in acciaio che consente la chiusura del contenitore,
 salvaguardando le ruote
*Half round steel support that safeguards the wheels during the
 closure of the tipping bucket*



CONTENITORE RIBALTABILE "PERTUTTO"
TIPPING CONTAINERS "PERTUTTO"

MODELLO MODEL	DIMENSIONI DIMENSIONS mm						PORTATA LOAD CAPACITY kg	VOLUME lit
	P1	P2	L	H1	H2	H3		
748R	930	720	750	695	850	740	580	280

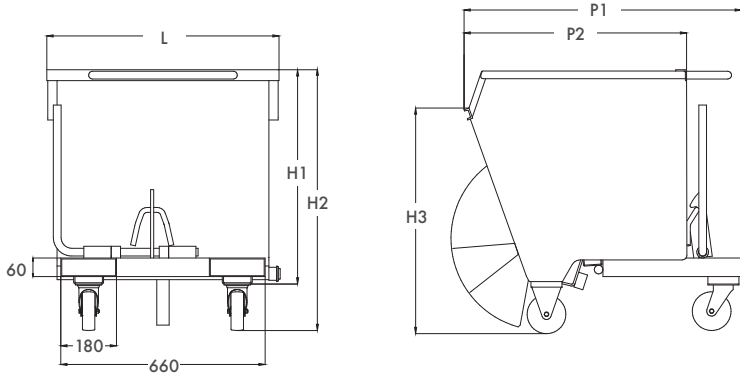

QUOTE SEDI FORCHE INTERNE | INTERNAL FORK SEATS DIMENSIONS

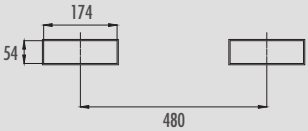

CONTENITORE RIBALTABILE "PERTUTTO"
TIPPING CONTAINERS "PERTUTTO"

MODELLO MODEL	DIMENSIONI DIMENSIONS mm						PORTATA LOAD CAPACITY kg	VOLUME lit
	P1	P2	L	H1	H2	H3		
750R	1250	1000	870	510	665	530	600	300

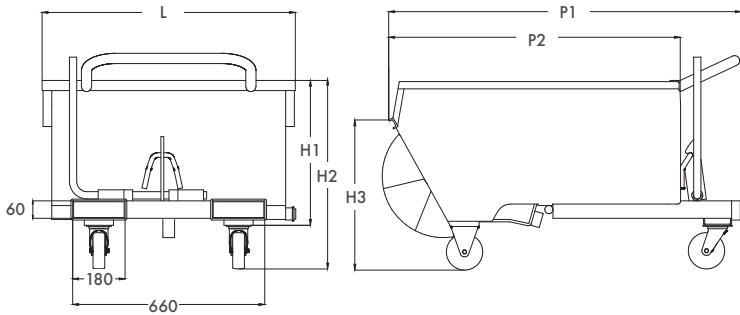

QUOTE SEDI FORCHE INTERNE | INTERNAL FORK SEATS DIMENSIONS

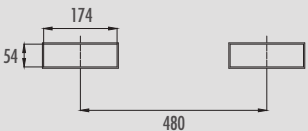

ACCESSORI | ACCESSORIES



CILINDRO IDRAULICO
HYDRAULIC CYLINDER
SECURE SYSTEM



COPERCHIO
COVER

CONTENITORE RIBALTABILE "PERTUTTO"
TIPPING CONTAINERS "PERTUTTO"

MODELLO MODEL	DIMENSIONI DIMENSIONS mm						PORTATA LOAD CAPACITY kg	VOLUME lit
	P1	P2	L	H1	H2	H3		
751R	1490	1130	975	655	875	715	1000	500
752R	1575	1290	1070	745	965	770	1350	750
753R	1680	1400	1070	900	1140	940	1500	1000

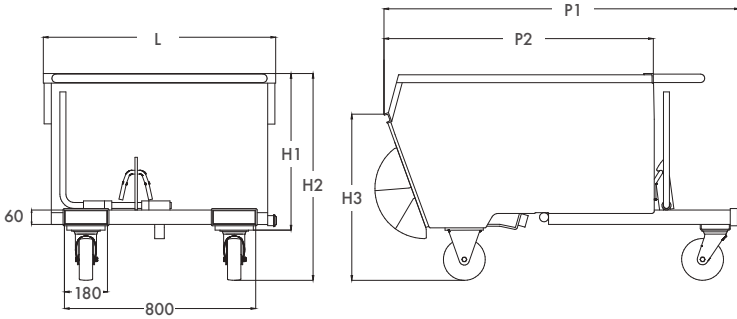

QUOTE SEDI FORCHE INTERNE | INTERNAL FORK SEATS DIMENSIONS

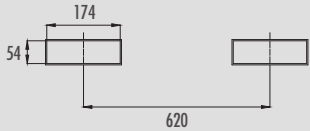

CONTENITORE RIBALTABILE "PERTUTTO" MAXI
TIPPING CONTAINERS "PERTUTTO" MAXI

MODELLO MODEL	DIMENSIONI DIMENSIONS mm						PORTATA LOAD CAPACITY kg	VOLUME lit
	P1	P2	L	H1	H2	H3		
756R	1780	1600	1785	1115	1490	1245	2000	2300



• Ruote in vulkollan
Vulkollan wheels

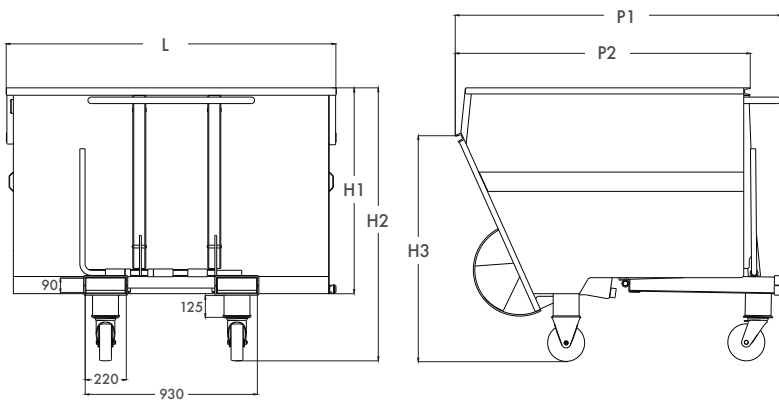

QUOTE SEDI FORCHE INTERNE | INTERNAL FORK SEATS DIMENSIONS

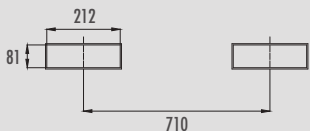

ACCESSORI | ACCESSORIES //



CILINDRO IDRAULICO
HYDRAULIC CYLINDER
SECURE SYSTEM



COPERCHIO
COVER



YOUTUBE VIDEO

// CONTENITORE RIBALTABILE "PERTUTTO" PER GRANDI VOLUMI
TIPPING CONTAINERS "PERTUTTO" FOR BIG VOLUMES

MODELLO MODEL	DIMENSIONI DIMENSIONS mm						PORTATA LOAD CAPACITY kg	VOLUME lit
	P1	P2	L	H1	H2	H3		
77B1800R	1630	1365	1065	920	1760	1160	900	1800

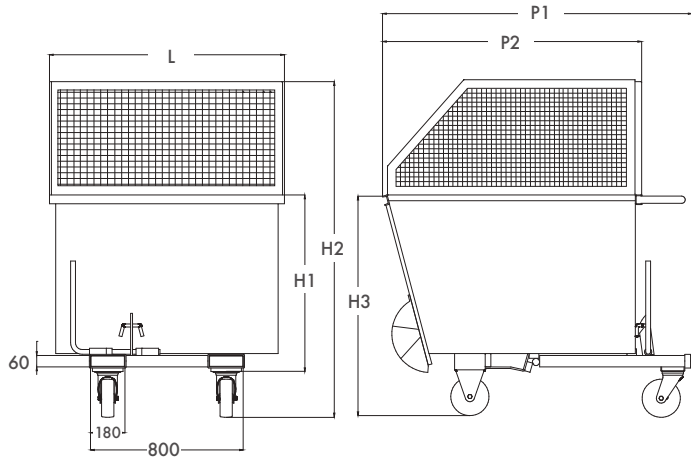

// QUOTE SEDI FORCHE INTERNE | INTERNAL FORK SEATS DIMENSIONS

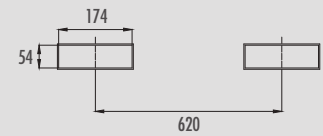

// CONTENITORE RIBALTABILE "PERTUTTO" PER GRANDI VOLUMI
TIPPING CONTAINERS "PERTUTTO" FOR BIG VOLUMES

MODELLO MODEL	DIMENSIONI DIMENSIONS mm						PORTATA CAPACITY kg	VOLUME lit
	P1	P2	L	H1	H2	H3		
77B2200R	1630	1365	1230	920	1760	1160	1000	2200

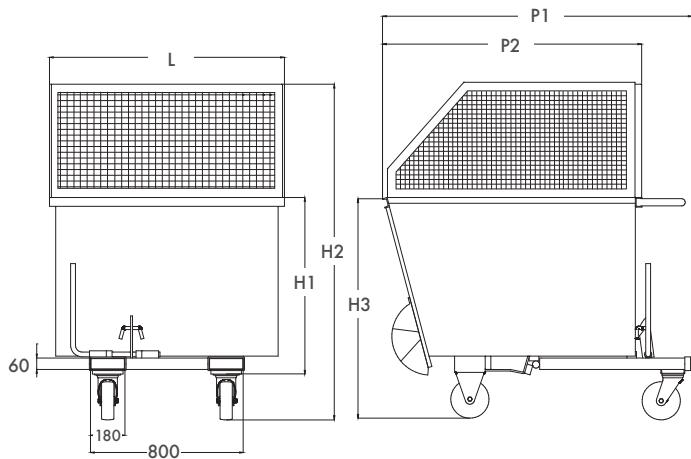

// QUOTE SEDI FORCHE INTERNE | INTERNAL FORK SEATS DIMENSIONS

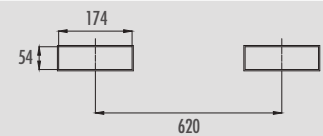

// ACCESSORI | ACCESSORIES



//////
CILINDRO IDRAULICO
HYDRAULIC CYLINDER
SECURE SYSTEM

CONTENITORE RIBALTABILE "PERTUTTO" PER ELEVATORE ELETTRICO TIMONATO
TIPPING CONTAINERS "PERTUTTO" FOR POWERED STACKERS

MODELLO MODEL	DIMENSIONI DIMENSIONS mm							PORTATA LOAD CAPACITY kg	VOLUME lit
	P1	P2	L	L1	H1	H2	H3		
748RS	930	720	750	865	695	850	740	580	280

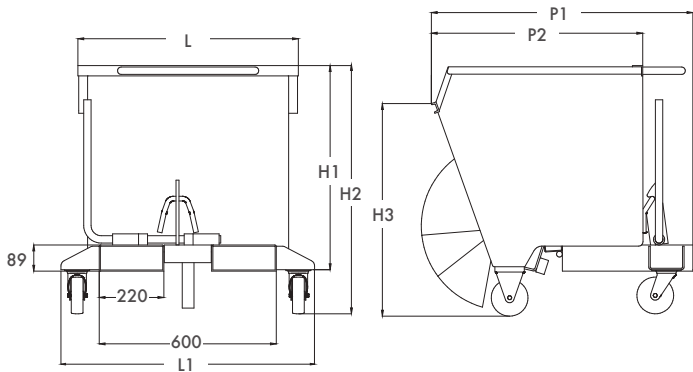

QUOTE SEDI FORCHE INTERNE | INTERNAL FORK SEATS DIMENSIONS

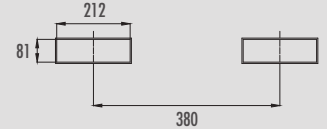

CONTENITORE RIBALTABILE "PERTUTTO" PER ELEVATORE ELETTRICO TIMONATO
TIPPING CONTAINERS "PERTUTTO" FOR POWERED STACKERS

MODELLO MODEL	DIMENSIONI DIMENSIONS mm							PORTATA LOAD CAPACITY kg	VOLUME lit
	P1	P2	L	L1	H1	H2	H3		
750RS	1250	1000	870	865	510	665	530	600	300

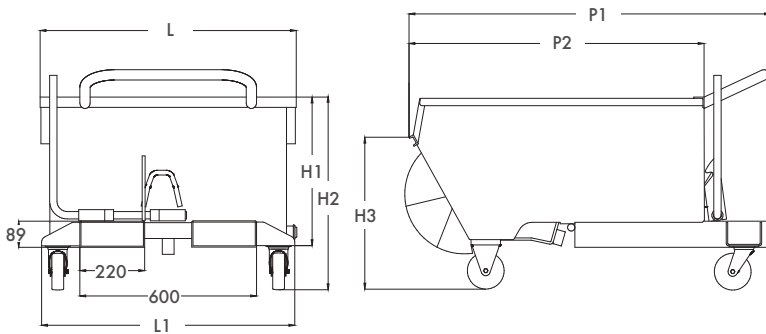

QUOTE SEDI FORCHE INTERNE | INTERNAL FORK SEATS DIMENSIONS

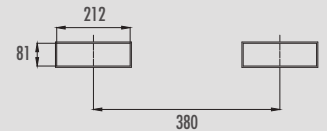

CONTENITORE RIBALTABILE "PERTUTTO" PER ELEVATORE ELETTRICO TIMONATO
TIPPING CONTAINERS "PERTUTTO" FOR POWERED STACKERS

MODELLO MODEL	DIMENSIONI DIMENSIONS mm							PORTATA LOAD CAPACITY kg	VOLUME lit
	P1	P2	L	L1	H1	H2	H3		
751RS	1490	1130	975	940	655	875	715	1000	500

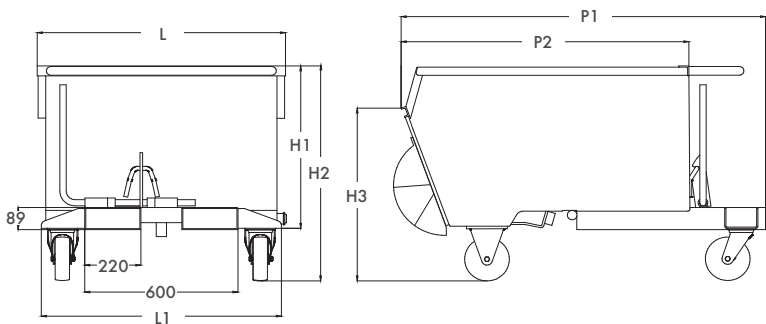

QUOTE SEDI FORCHE INTERNE | INTERNAL FORK SEATS DIMENSIONS

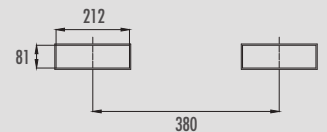

ACCESSORI | ACCESSORIES



CILINDRO IDRAULICO
HYDRAULIC CYLINDER
SECURE SYSTEM



COPERCHIO
COVER

// CARRELLO PORTA BARRE "CARGO"
"CARGO" BAR CART

- Ideale per barre di 3-4 metri di lunghezza
Ideal for bars of 3-4 meters length
- Ruote girevoli con freno
Rotating wheels with brake

MODELLO MODEL	DIMENSIONI DIMENSIONS mm				PORTATA LOAD CAPACITY kg
	L	P	H1	H2	
938PBR10	2500	600	890	390	1000
938PBR20	2500	600	900	410	2000

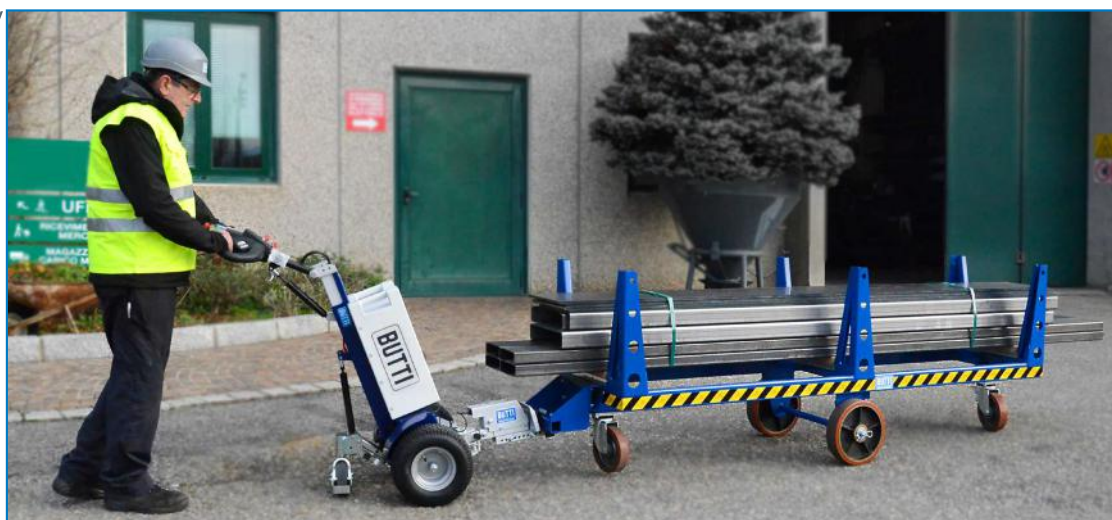
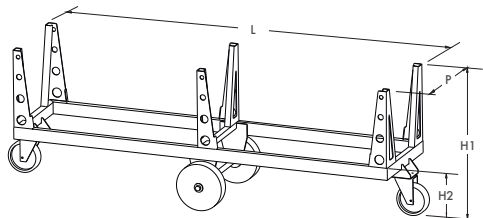

// TRAINATORE ELETTRICO T-15
VERTICAL ELECTRIC TUG T-15

- Ideale per l'utilizzo con il cargo porta barre
Ideal for use with the cargo bar cart
- Fornito di serie con: kit predisposizione accessorio elettrico; pacco batterie AGM - 37/45Ah (fino a 8 ore di utilizzo intenso); kit fissaggio pacco batterie 30Ah, 45Ah e Litio; supporto gancio con braccio a molla 35x35 mm; gancio pinza elettrica.
Delivered with: configuration kit for electric accessory; AGM battery pack - 37/45Ah (up to 8 hours of use); Fitting kit for battery pack 30Ah, 45Ah and Lithium; Pivoting support arm for hitches 35x35 mm; Electric clamp hitch.

MODELLO MODEL	DIMENSIONI DIMENSIONS mm			PORTATA LOAD CAPACITY kg
	L	P	H	
938T15	1370	535	1056	1500



// ACCESSORI | ACCESSORIES



KIT "LOAD UP" | "LOAD UP" KIT

Kit composto da tre elementi posizionati sulla base del carrello in corrispondenza dei montanti di contenimento. Permette al carico di restare sollevato dalla base di appoggio consentendo all'operatore di entrare ed uscire con le forche del carrello elevatore una volta posizionato il carico.
Kit composed by three elements placed on the base of the cart in correspondence of the loading area. It allows the load to remain higher from the support base allowing the operator to enter and exit with the forks of the forklift once the load is positioned.



99C524

KIT GANCIO TRAINATORE | TOWING HITCH KIT
Kit composto da supporti che permette di agganciare il cargo portabarre Butti al trainatore elettrico.
Kit made up of supports which allows the Butti cargo bar-holder to be hooked up to the vertical electric tug.

CAVALLETTO INDUSTRIALE "BIG WORKS" - SERIE ONE
SERIES ONE - "BIG WORKS" INDUSTRIAL TRESTLES

MODELLO MODEL	DIMENSIONI DIMENSIONS mm				PORTATA LOAD CAPACITY kg
	L	P1	P2	H	
156A05H909	900	750	60	850	500
156A10H909	900	750	60	850	1000
156A10H9A2	1200	750	60	850	1000
156A20H9A2	1200	750	80	850	2000
156A10H9A5	1500	750	60	850	1000
156A20H9	1500	750	80	850	2000
156A20H9A8	1800	750	80	850	2000
156A30H9A8	1800	750	80	850	3000

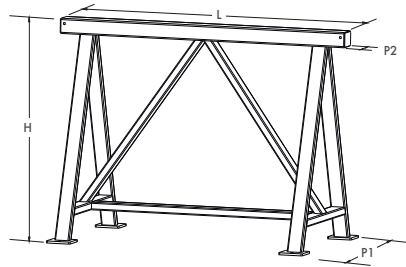

• **ESECUZIONE:**
Piano di appoggio in ACCIAIO o LEGNO (con il piano in legno l'altezza del cavalletto aumenta di 50 mm)
• **EXECUTION:**
Support surface in STEEL or WOOD (with the wooden surface, the height of the trestles increases by 50 mm)

CAVALLETTO INDUSTRIALE "BIG WORKS"
"BIG WORKS" INDUSTRIAL TRESTLES

MODELLO MODEL	DIMENSIONI DIMENSIONS mm				PORTATA LOAD CAPACITY kg
	L	P1	P2	H	
156A10H3L	400	260	100	300	1000

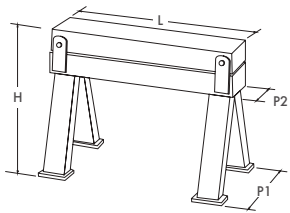

CAVALLETTO INDUSTRIALE "BIG WORKS"
"BIG WORKS" INDUSTRIAL TRESTLES

MODELLO MODEL	DIMENSIONI DIMENSIONS mm				PORTATA LOAD CAPACITY kg
	L	P1	P2	H	
156A150R	350	400	80	320	15000
				370	
				420	
				465	

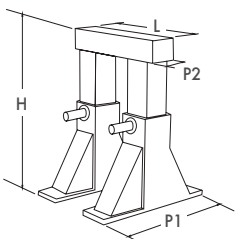

I CAVALLETTI SONO COSTRUITI E COLLAUDATI SECONDO LA NORMA EN1090-2 E ACCOMPAGNATI DA RELATIVA DICHIARAZIONE DI COSTRUZIONE. LA NORMATIVA CE NON È APPLICABILE AI CAVALLETTI INDUSTRIALI IN QUANTO NON ASSOGGETTATI ALLA DIRETTIVA MACCHINE. THE TRESTLES ARE CONSTRUCTED AND TESTED ACCORDING TO THE EN 1090-2 STANDARD AND ACCOMPANIED BY A RELATIVE CONSTRUCTION STATEMENT. THE EC REGULATION IS NOT APPLICABLE TO THE INDUSTRIAL TRESTLES SINCE THEY ARE NOT SUBJECT TO THE MACHINE DIRECTIVE.

SCAFFALATURE INDUSTRIALI PROFESSIONALI
PROFESSIONAL INDUSTRIAL SHELVINGS

MODELLO MODEL	DIMENSIONI DIMENSIONS mm			PORTATA PER OGNI RIPIANO LOAD CAPACITY FOR EACH SHELF kg	RIPIANI SHELVES n.
	L	P	H		
809K12P015R3	1200	500	1500	160 distribuiti/distributed	3
809K12P015R4	1200	500	2000	160 distribuiti/distributed	4
809KM12P015	1200	500	2500	160 distribuiti/distributed	5
809K12P015R6	1200	500	3000	160 distribuiti/distributed	6

- DOTATE DI SISTEMA IMBULLONATO PENSATO PER GARANTIRE LA MASSIMA SICUREZZA
EQUIPPED WITH A BOLTED SYSTEM DESIGNED TO GUARANTEE MAXIMUM SAFETY
- STRUTTURA ROBUSTA E RESISTENTE
STRONG AND RESISTANT STRUCTURE
- IL MIGLIOR RAPPORTO QUALITÀ/PREZZO SUL MERCATO
THE BEST QUALITY/PRICE RATIO ON THE MARKET

• RIPIANI AGGIUNTIVI ACQUISTABILI
SU RICHIESTA
ADDITIONAL SHELVES CAN BE
PURCHASED ON DEMAND

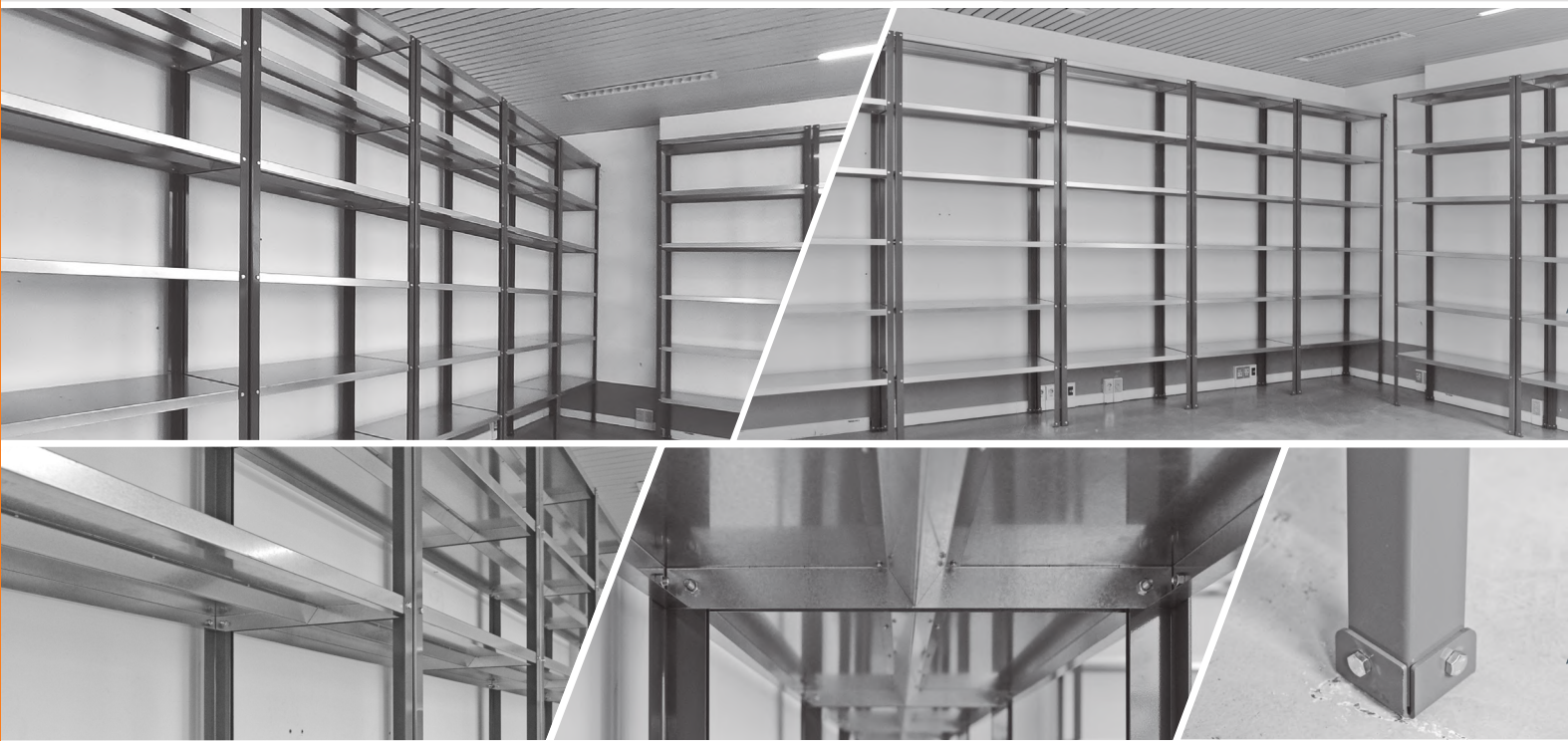
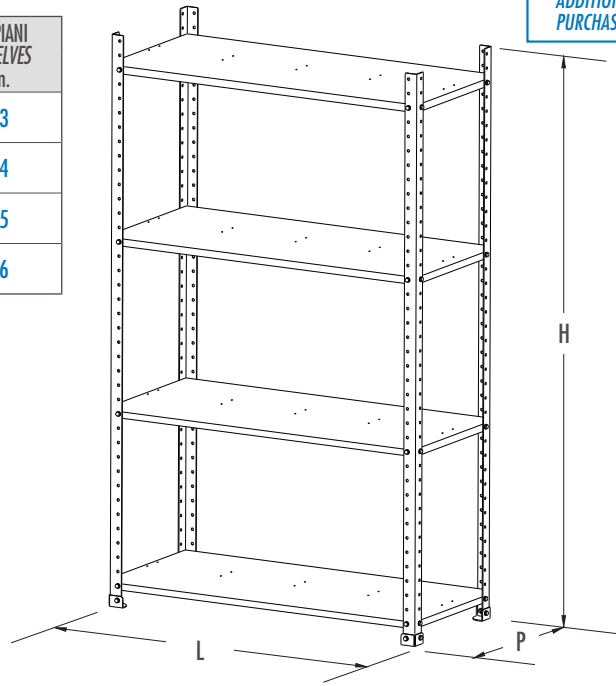

BARELLE PER STOCCAGGIO
STORAGE STRETCHERS

MODELLO MODEL	DIMENSIONI DIMENSIONS mm			PORTATA LOAD CAPACITY kg
	L	P	H	
174P075SF	1500	850	650	750

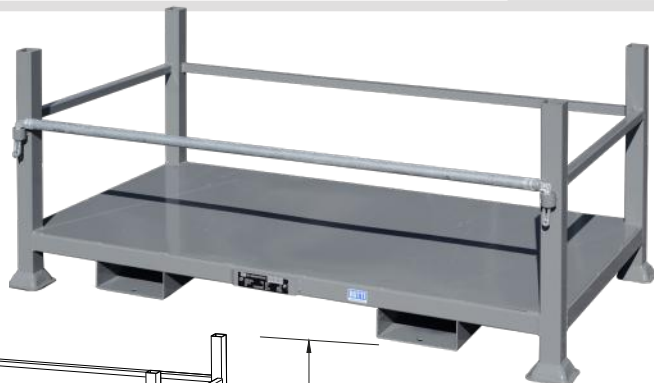

• Sovrapposibilità statica
3 su 1 a pieno carico
Static overlap of 3 to 1
at full load

• Ideali per stoccaggio di
pallet 1200x800 mm
Ideal for the storage of
1200x800 mm pallets

QUOTE SEDI FORCHE INTERNE | INTERNAL FORK SEATS DIMENSIONS

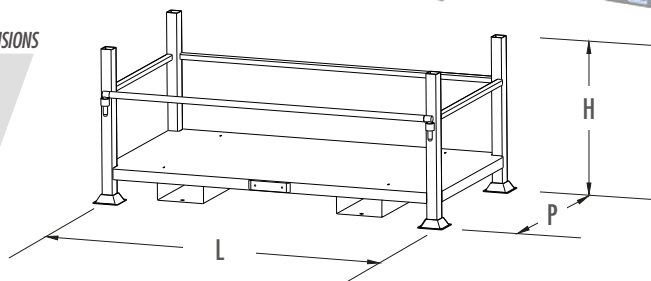
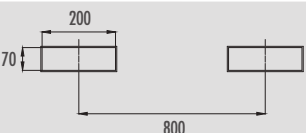

CONTENITORI A FONDO APRIBILE "COMPACT" MINI
CONTAINERS WITH OPENABLE BOTTOM "COMPACT" MINI

MODELLO MODEL	DIMENSIONI DIMENSIONS mm				PORTATA LOAD CAPACITY kg	VOLUME lt
	L	P	H	H2		
637A	880	660	930	660	300	240

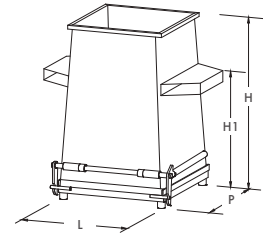

CONTENITORI A FONDO APRIBILE "COMPACT" ECO CON RUOTE
CONTAINERS WITH OPENABLE BOTTOM "COMPACT" ECO WITH WHEELS

MODELLO MODEL	DIMENSIONI DIMENSIONS mm			PORTATA LOAD CAPACITY kg	VOLUME lt
	L	P	H		
637L05C	1195	900	815	500	500
637L10C	1195	900	1265	600	1000

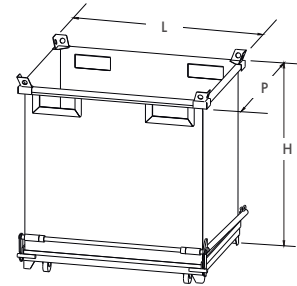

- Pareti dritte
Straight sides
- Con ruote
With wheels
- Impilabili
Stackable

- Impilabili a vuoto
Stackable empty



CONTENITORI A FONDO APRIBILE "COMPACT" 1000
CONTAINERS WITH OPENABLE BOTTOM "COMPACT" 1000

MODELLO MODEL	DIMENSIONI DIMENSIONS mm			PORTATA LOAD CAPACITY kg	VOLUME lt
	L	P	H		
637	1335	1035	1205	1700	1000
637R con ruote with wheels	1335	1035	1445	1700	1000

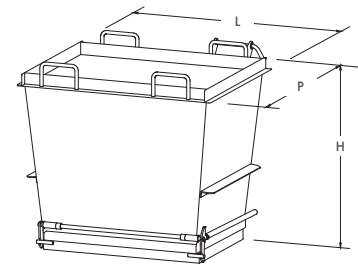

YOUTUBE VIDEO

CONTENITORI A FONDO APRIBILE "COMPACT" 3000
CONTAINERS WITH OPENABLE BOTTOM "COMPACT" 3000

MODELLO MODEL	DIMENSIONI DIMENSIONS mm			PORTATA LOAD CAPACITY kg	VOLUME lt
	L	P	H		
638	2110	1535	1330	5100	3000

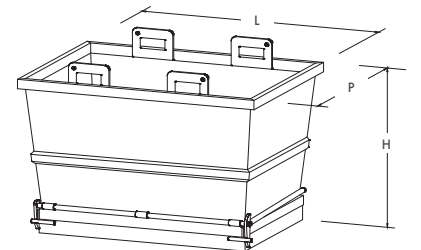

CONTENITORI A FONDO APRIBILE "COMPACT" 4000
CONTAINERS WITH OPENABLE BOTTOM "COMPACT" 4000

MODELLO MODEL	DIMENSIONI DIMENSIONS mm			PORTATA LOAD CAPACITY kg	VOLUME lt
	L	P	H		
638L40	2250	1535	1700	6800	4000

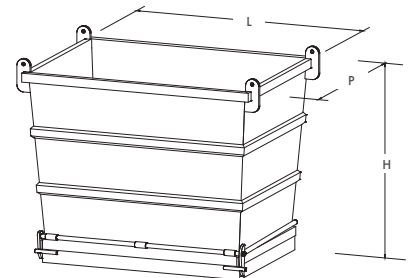

QUOTE SEDI FORCHE INTERNE | INTERNAL FORK SEATS DIMENSIONS



MODELLO MODEL	DIMENSIONI DIMENSIONS mm		
	A	B	C
637A	65	220	770
637L05C	80	220	700
637L10C	80	220	700
637	65	220	770
637R	65	220	770
638	90	220	880
638L40	senza sedi forche without fork seats		

ACCESSORI | ACCESSORIES



CATENA 4 RAMI
4 LEGS CHAIN



MODELLO MODEL	CATENA CHAIN Ø	LUNGHEZZA LENGHT m	PORTATA LOAD CAPACITY kg
594B3	8	3	4250
594B4	8	4	4250

// CONTENITORE PER FORCHE ROTANTI
CONTAINER FOR ROTATING FORKS

MODELLO MODEL	DIMENSIONI DIMENSIONS mm			TARA TARE kg	PORTATA LOAD CAPACITY kg	VOLUME li
	L	P	H			
73B1345X	1280	1100	1180	180	1000	1345

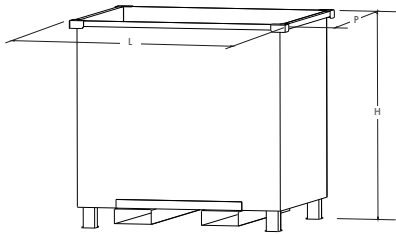

- Inforcabile con carrello elevatore a forche rotanti
Forkable with forklift with rotating forks



- Sovrapposibilità statica 2 su 1 a pieno carico
Static overlap of 2 to 1 at full load

// QUOTE SEDI FORCHE INTERNE | INTERNAL FORK SEATS DIMENSIONS

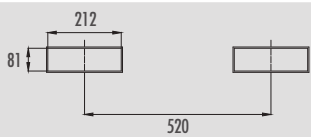

// CONTENITORE IN LAMIERA PER PARABREZZA
SHEET METAL CONTAINER FOR WINDSHIELDS

MODELLO MODEL	DIMENSIONI DIMENSIONS mm					TARA TARE kg	PORTATA LOAD CAPACITY kg
	L1	L2	P1	P2	H		
886BB15	2325	2400	1100	1175	760	210	1500

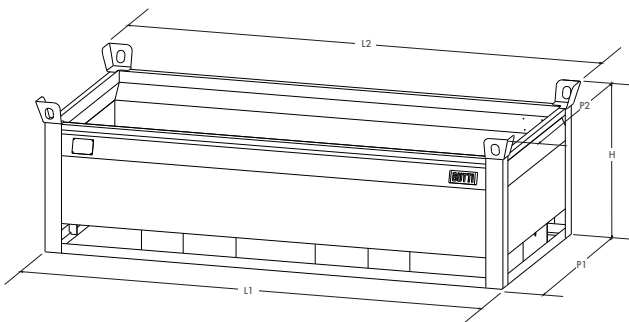

- Sovrapposibilità statica 3 su 1 a pieno carico
Static overlap of 3 to 1 at full load



// QUOTE SEDI FORCHE INTERNE | INTERNAL FORK SEATS DIMENSIONS

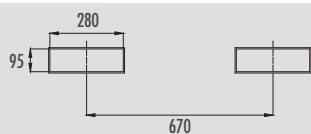

CONTENITORE IN METALLO
METAL CONTAINER

MODELLO MODEL	DIMENSIONI DIMENSIONS mm					TARA TARE kg	PESO PIENO CARICO TOTAL FULL LOAD WEIGHT kg	PORTATA LOAD CAPACITY kg
	L	P	H1	H2	H3			
621	700	650	450	150	60	30	630	600

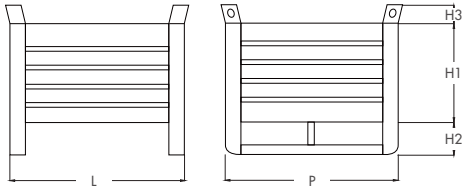

• Sovrapposibilità statica
3 su 1 a pieno carico
Static overlap of 3 to 1
at full load

CONTENITORE IN METALLO A BOCCA DI LUPO
METAL CONTAINER WITH FRONTAL OPENING

MODELLO MODEL	DIMENSIONI DIMENSIONS mm					TARA TARE kg	PESO PIENO CARICO TOTAL FULL LOAD WEIGHT kg	PORTATA LOAD CAPACITY kg
	L	P	H1	H2	H3			
622L	800	600	400	120	60	35	635	600

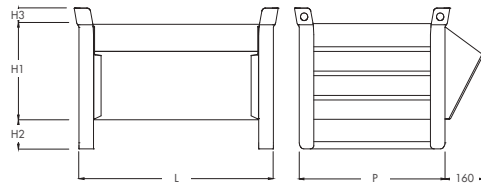

• Sovrapposibilità statica
3 su 1 a pieno carico
Static overlap of 3 to 1
at full load

CONTENITORE IN METALLO
METAL CONTAINER

MODELLO MODEL	DIMENSIONI DIMENSIONS mm					TARA TARE kg	PESO PIENO CARICO TOTAL FULL LOAD WEIGHT kg	PORTATA LOAD CAPACITY kg
	L	P	H1	H2	H3			
625	1000	800	650	150	100	92	2092	2000

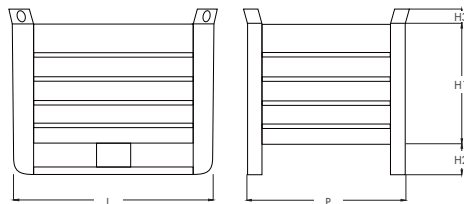

• Sovrapposibilità statica
3 su 1 a pieno carico
Static overlap of 3 to 1
at full load

CONTENITORE IN METALLO CON SPORTELLO
METAL CONTAINER WITH DOOR

MODELLO MODEL	DIMENSIONI DIMENSIONS mm					TARA TARE kg	PESO PIENO CARICO TOTAL FULL LOAD WEIGHT kg	PORTATA LOAD CAPACITY kg
	L	P	H1	H2	H3			
625S	1000	800	650	150	100	99	2099	2000

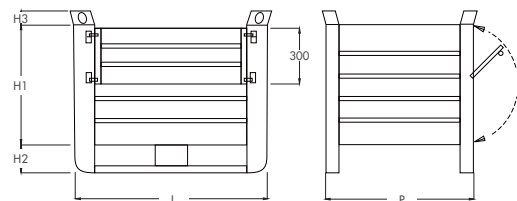

• Sovrapposibilità statica
3 su 1 a pieno carico
Static overlap of 3 to 1
at full load

CONTENITORE IN METALLO
METAL CONTAINER

MODELLO MODEL	DIMENSIONI		DIMENSIONS mm			TARA TARE kg	PESO PIENO CARICO TOTAL FULL LOAD WEIGHT kg	PORTATA LOAD CAPACITY kg
	L	P	H1	H2	H3			
626	1200	800	650	150	60	64	1064	1000

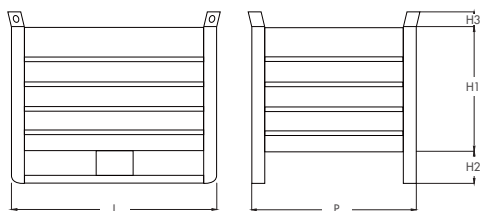

• Sovrapposibilità statica
3 su 1 a pieno carico
Static overlap of 3 to 1
at full load

CONTENITORE IN METALLO CON SPORTELLO
METAL CONTAINER WITH DOOR

MODELLO MODEL	DIMENSIONI		DIMENSIONS mm			TARA TARE kg	PESO PIENO CARICO TOTAL FULL LOAD WEIGHT kg	PORTATA LOAD CAPACITY kg
	L	P	H1	H2	H3			
626S	1200	800	650	150	60	69	1069	1000

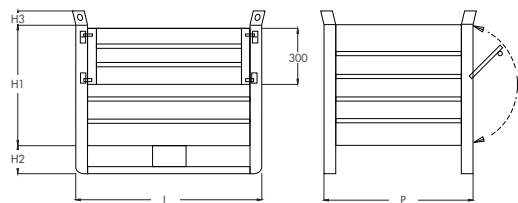

• Sovrapposibilità statica
3 su 1 a pieno carico
Static overlap of 3 to 1
at full load

CONTENITORE IN METALLO PESANTE CON FONDO E BORDO INFERIORE RINFORZATO
HEAVY METAL CONTAINER WITH REINFORCED BOTTOM AND LOWER EDGE

MODELLO MODEL	DIMENSIONI		DIMENSIONS mm			TARA TARE kg	PESO PIENO CARICO TOTAL FULL LOAD WEIGHT kg	PORTATA LOAD CAPACITY kg
	L	P	H1	H2	H3			
628I15XP	1500	800	750	150	100	145	1645	1500

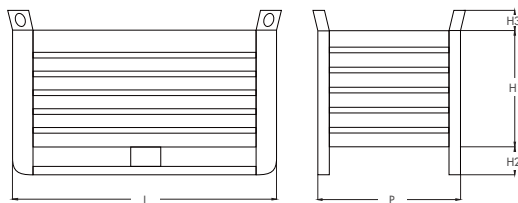

• Sovrapposibilità statica
3 su 1 a pieno carico
Static overlap of 3 to 1
at full load

CONTENITORE IN METALLO
METAL CONTAINER

MODELLO MODEL	DIMENSIONI		DIMENSIONS mm			TARA TARE kg	PESO PIENO CARICO TOTAL FULL LOAD WEIGHT kg	PORTATA LOAD CAPACITY kg
	L	P	H1	H2	H3			
629	1700	800	450	150	100	85	585	500

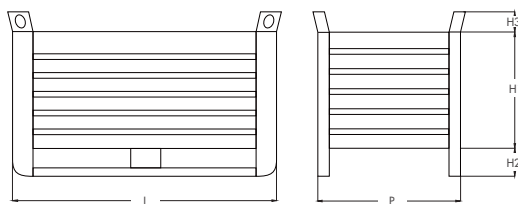

• Sovrapposibilità statica
3 su 1 a pieno carico
Static overlap of 3 to 1
at full load

CONTENITORE IN RETE
MESH CONTAINER

MODELLO MODEL	DIMENSIONI DIMENSIONS mm					TARA TARE kg	PESO PIENO CARICO TOTAL FULL LOAD WEIGHT kg	PORTATA LOAD CAPACITY kg
	L	P	H1	H2	H3			
624R	1000	800	650	150	60	50	1050	1000
626R	1200	800	650	150	60	51	1051	1000

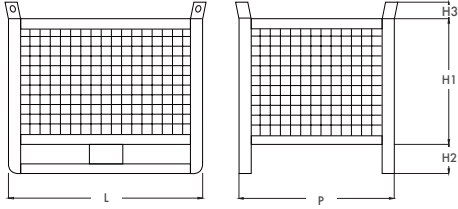

• Sovrapponibilità statica
3 su 1 a pieno carico
Static overlap of 3 to 1
at full load

CONTENITORE IN RETE CON SPORTELLO
MESH CONTAINER WITH DOOR

MODELLO MODEL	DIMENSIONI DIMENSIONS mm					TARA TARE kg	PESO PIENO CARICO TOTAL FULL LOAD WEIGHT kg	PORTATA LOAD CAPACITY kg
	L	P	H1	H2	H3			
626RS	1200	800	650	150	60	60	1060	1000

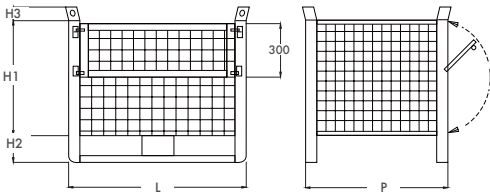

• Sovrapponibilità statica
3 su 1 a pieno carico
Static overlap of 3 to 1
at full load

CONTENITORE RIPIEGHEVOLE E SOVRAPPONIBILE IN RETE
MESH COLLAPSIBLE OVERLAPPING CONTAINER

MODELLO MODEL	DIMENSIONI DIMENSIONS mm			PORTATA LOAD CAPACITY kg
	L	P	H	
881B1ORSZ esterne external	1200	800	980	1000
881B1ORSZ interne internal	1120	730	810	1000
881B1ORSZ ripiegato collapsed	1200	800	330	-

A richiesta con 4 ruote, 2 fisse e 2 girevoli
On demand with 4 wheels, 2 fixed and 2 swiveling



• Sovrapponibilità statica
3 su 1 a pieno carico
con sportello chiuso
Static overlap of 3 to 1
at full load with closed
door



CONTENITORE IN POLIETILENE
POLYETHYLENE CONTAINER

MODELLO MODEL	DIMENSIONI DIMENSIONS mm			PORTATA LOAD CAPACITY kg
	L	P	H	
626POL	1200	800	800	500



ACCESSORI | ACCESSORIES



99C380
COPERCHIO PER CONTENITORE IN
POLIETILENE DISPONIBILE SU RICHIESTA
LID FOR POLYETHYLENE CONTAINER
AVAILABLE ON REQUEST

// DEPOSITO PER BOMBOLE GAS COMPRESSI
STORAGE CONTAINER FOR COMPRESSED GAS CYLINDERS

MODELLO MODEL	DIMENSIONI DIMENSIONS mm			PORTATA CAPACITY
	L	P	H	
88701121	1120	945	2120	9-12 bombole 9-12 cylinders

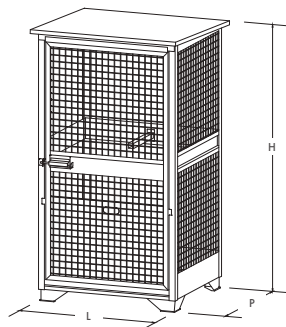

- Zincato a caldo
Hot-dip galvanized
- Con un'anta
With one door
- Scivolo incluso
Slide included

// PALLET PER BOMBOLE
PALLET FOR GAS CYLINDER

MODELLO MODEL	DIMENSIONI DIMENSIONS mm			PORTATA CAPACITY
	L	P	H	
88701121X	1030	860	960	12 bombole 12 cylinders

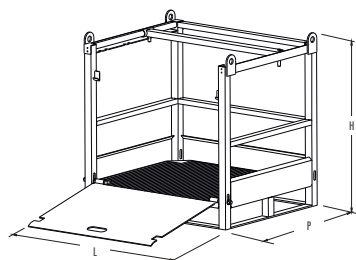

- Zincato a caldo
Hot-dip galvanized
- Con ganci di sollevamento
With lifting hooks and
- Con sedi forche
With fork seats
- Scivolo incluso
Slide included

// PALLET PER BOMBOLE
PALLET FOR GAS CYLINDER

MODELLO MODEL	DIMENSIONI DIMENSIONS mm			PORTATA CAPACITY
	L	P	H	
887010811	860	650	1240	4 bombole 4 cylinders

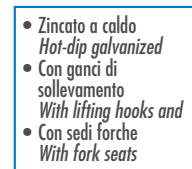
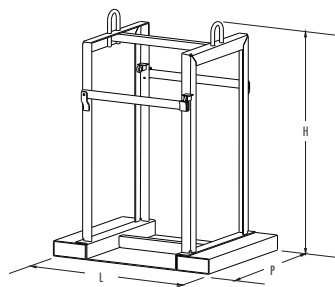

- Zincato a caldo
Hot-dip galvanized
- Con ganci di sollevamento
With lifting hooks and
- Con sedi forche
With fork seats

// QUOTE SEDI FORCHE INTERNE | INTERNAL FORK SEATS DIMENSIONS

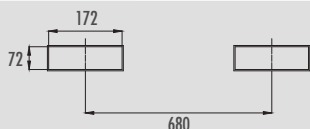

// ACCESSORI | ACCESSORIES



99C444
RICAMBIO PER CINGHIA DI TRATTENUTA CARICO
REPLACEMENT FOR LOAD HOLDING STRAP



CRICCHETTO CON GANCIO A TONDINO PER CINGHIA PROFESSIONALE
RATCHET WITH ROD HOOK FOR PROFESSIONAL STRAPS

////// ARMADI DI SICUREZZA
SAFETY CABINETS

MODELLO MODEL	UTILIZZO USE	DIMENSIONI DIMENSIONS mm			VERNICIATURA PAINTING	RIPIANI SHELVES
		L	P	H		
98RARM12	Sostanze pericolose <i>Dangerous substances</i>	1000	460	1000	Giallo <i>Yellow</i>	2
98RARMF2	Fitosanitari <i>Plant protection products</i>	1000	460	1000	Verde <i>Green</i>	2
98RARM3C	Sostanze chimiche e corrosive <i>Chemical and corrosive products</i>	1075	500	1100	Blu - Blue RAL 5015 Epossipoliestere resistente a agenti chimici/corrosivi <i>Epoxy-polyester resistant to chemical/corrosive agents</i>	2

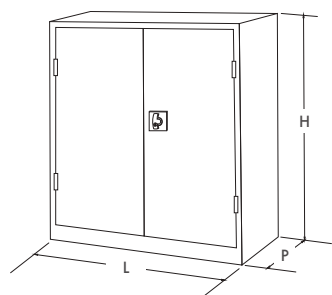

////// ARMADI DI SICUREZZA
SAFETY CABINETS

MODELLO MODEL	UTILIZZO USE	DIMENSIONI DIMENSIONS mm			VERNICIATURA PAINTING	RIPIANI SHELVES
		L	P	H		
98RARM13	Sostanze pericolose <i>Dangerous substances</i>	1000	460	1800	Giallo <i>Yellow</i>	3
98RARMF3	Fitosanitari <i>Plant protection products</i>	1000	460	1800	Verde <i>Green</i>	3
98RARM1C	Sostanze chimiche e corrosive <i>Chemical and corrosive products</i>	1075	500	1850	Blu - Blue RAL 5015 Epossipoliestere resistente a agenti chimici/corrosivi <i>Epoxy-polyester resistant to chemical/corrosive agents</i>	3

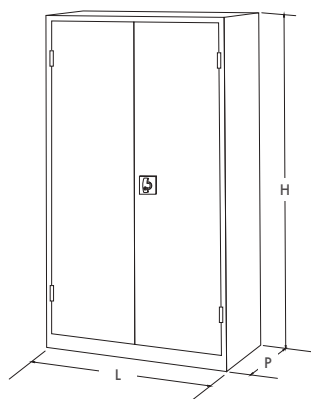

24H - VALIGETTA PORTA ATTREZZI
24H - TOOL CASE

MODELLO MODEL	DIMENSIONI DIMENSIONS mm			TARA TARE kg
	L	P	H	
343V48	480	290	180	4



BAULI PORTA ATTREZZI
TOOLS CHESTS

MODELLO MODEL	DIMENSIONI DIMENSIONS mm			TARA TARE kg
	L	P	H	
344B65	650	360	300	9
344B75	750	410	350	11

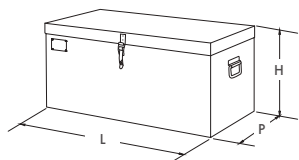

PORTA UTENSILI
TOOLS HOLDER

MODELLO MODEL	DIMENSIONI DIMENSIONS mm			VOLUME lt	TARA TARE kg
	L	P	H		
345	850	500	435	170	27

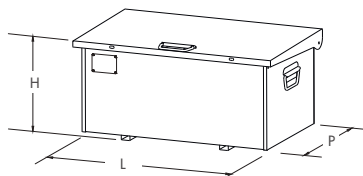

- Con coperchio zincato
With zinc coated lid
- Lucchetti CISA di serie
CISA padlock included



PORTA ATTREZZI
TOOLS HOLDER

MODELLO MODEL	DIMENSIONI DIMENSIONS mm			TARA TARE kg	PESO PIENO CARICO TOTAL FULL LOAD WEIGHT kg	VOLUME lt	PORTATA LOAD CAPACITY kg
	L	P	H				
350	1000	500	750	50	350	350	300
350Z zincato zinc coated	1000	500	750	53	353	350	300

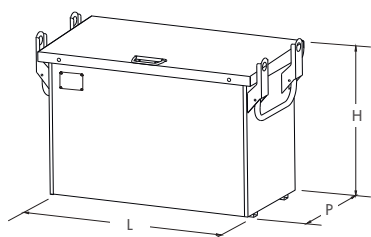

- Con coperchio zincato
With zinc coated lid
- Lucchetti CISA di serie
CISA padlock included



PORTA ATTREZZI
TOOLS HOLDER

MODELLO MODEL	DIMENSIONI DIMENSIONS mm			TARA TARE kg	PESO PIENO CARICO TOTAL FULL LOAD WEIGHT kg	VOLUME lit	PORTATA LOAD CAPACITY kg
	L	P	H				
351	1000	1000	790	77	577	700	500
351Z zincato zinc coated	1000	1000	790	83	589	700	500

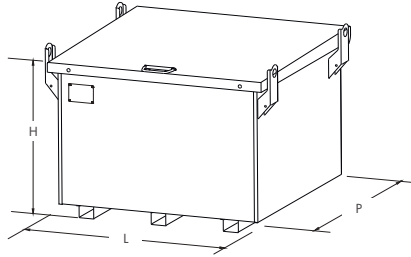

- Con coperchio zincato
With zinc coated lid
- Lucchetti CISA di serie
CISA padlock included



PORTA ATTREZZI
TOOLS HOLDER

MODELLO MODEL	DIMENSIONI DIMENSIONS mm			TARA TARE kg	PESO PIENO CARICO TOTAL FULL LOAD WEIGHT kg	VOLUME lit	PORTATA LOAD CAPACITY kg
	L	P	H				
352	1780	550	660	84	434	550	350
352Z zincato zinc coated	1780	550	660	88	438	550	350

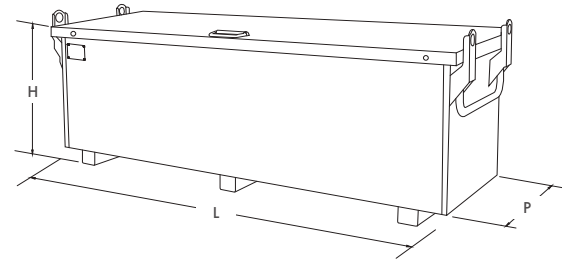

- Con coperchio zincato
With zinc coated lid
- 2 lucchetti CISA di serie
2 CISA padlock included



PORTA ATTREZZI PER NISSAN - MODELLO COMPATTO
TOOLS HOLDER FOR NISSAN - COMPACT MODEL

MODELLO MODEL	DIMENSIONI DIMENSIONS mm			TARA TARE kg	PESO PIENO CARICO TOTAL FULL LOAD WEIGHT kg	VOLUME lit	PORTATA LOAD CAPACITY kg
	L	P	H				
354N	1650	550	660	76	426	510	350
354NZ zincato zinc coated	1650	550	660	80	430	510	350

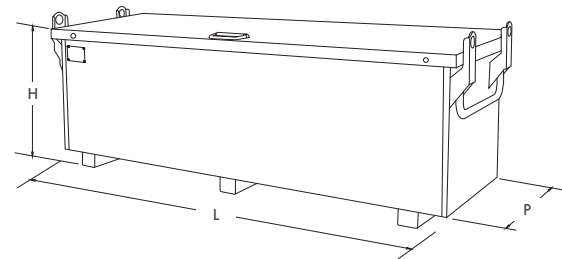

- Con coperchio zincato
With zinc coated lid
- 2 lucchetti CISA di serie
2 CISA padlock included



ACCESSORI | ACCESSORIES



99C256 - 99C187
BARRA ANTISCASSO CON LUCCHETTO
CISA ANTIFURTO PER PORTA ATTREZZI
351/351Z/352/352Z/354N/354NZ
BURGLAR BAR WITH PADLOCK CISA
THEFT PROTECTION FOR TOOLS HOLDER
351/351Z/352/352Z/354N/354NZ



354N - 354NZ
Per venire incontro ad ogni esigenza di trasporto, abbiamo creato un porta
attrezzi specifico per furgone NISSAN: ha le stesse caratteristiche di quello
standard, ma risulta più compatto e quindi adatto per questo veicolo.
In order to meet every need of transport, we have created a specific
tool holder for NISSAN cargo van: it has the same characteristics as the
standard one, but is more compact and therefore suitable for this type
of vehicle.

PORTA ATTREZZI CON UNO SPORTELLO LATERALE
TOOLS HOLDER WITH DOOR ON ONE SIDE

MODELLO MODEL	DIMENSIONI DIMENSIONS mm			TARA TARE kg	PESO PIENO CARICO TOTAL FULL LOAD WEIGHT kg	VOLUME lt	PORTATA LOAD CAPACITY kg
	L	P	H				
353C	1900	1000	670	134	484	1070	350

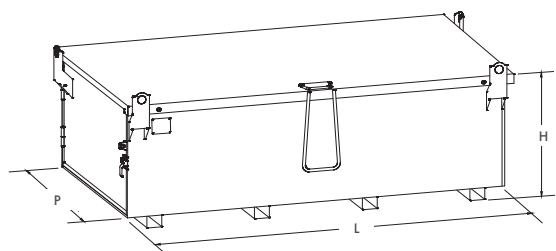

- Con coperchio zincato
With zinc coated lid
- 2 lucchetti CISA di serie
2 CISA padlock included



ARMADIO SICURBOX
SICURBOX CABINET

MODELLO MODEL	DIMENSIONI DIMENSIONS mm			TARA TARE kg	PESO PIENO CARICO TOTAL FULL LOAD WEIGHT kg	RIPIANI SHELVES	PORTATA LOAD CAPACITY kg
	L	P	H				
355	1000	700	1500	114	414	2	300

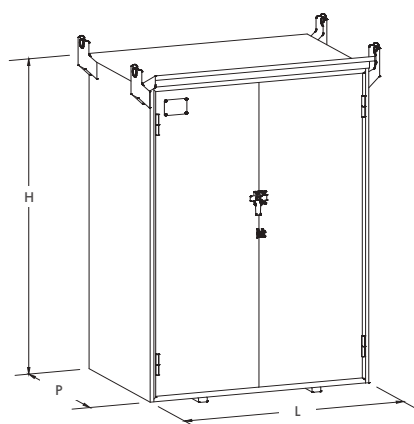

- Su richiesta con 4 ruote
On demand with 4 wheels

- Lucchetti CISA di serie
CISA padlock included



- Con due ripiani interni
With two internal shelves

ACCESSORI | ACCESSORIES



99C256 - 99C187
BARRA ANTISCASSO CON LUCCHETTO CISA ANTIFURTO
PER PORTA ATTREZZI 353C
BURGLAR BAR WITH PADLOCK CISA THEFT PROTECTION
FOR TOOLS HOLDER 353C

TRAMOGGIA PORTA "BIG-BAG" SMONTABILE
REMOVABLE "BIG-BAG" HOPPER



MODELLO MODEL	DIMENSIONI DIMENSIONS mm							TARA TARE kg	PORTATA LOAD CAPACITY kg
	L1xP1	L2xP2	L3xP3 utile useful	H1	H2	H3	H4		
873TB16	1600x1400	1675x1675	1440x1240	2330	2930	1530	2130	335	2000

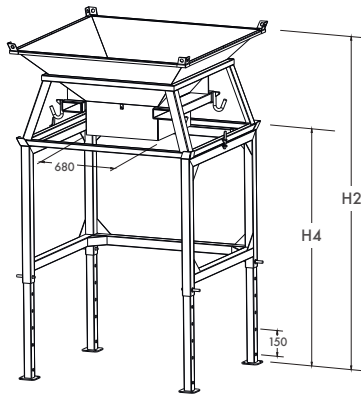
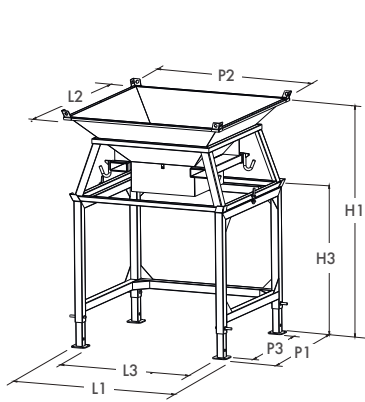

- MOVIMENTAZIONE DEL SACCO FACILITATA
EASY BAG HANDLING
- AMPIA BOCCA DI CARICO
WIDE INSERTION FUNNEL
- ALTEZZA REGOLABILE CON PASSI DA 150 mm
ADJUSTABLE HEIGHT WITH 150 mm STEPS
- ROBUSTA STRUTTURA IN ACCIAIO
STURDY STEEL STRUCTURE
- GANCI SALDATI PER FISSARE IL "BIG-BAG" AGEVOLMENTE
WELDED HOOKS TO FIX EASILY THE "BIG-BAG"
- 4 ATTACCHI SUPERIORI SUL BORDO DELL'IMBUTO PER SOLLEVAMENTO CON GRU A VUOTO
4 HOOKS FOR BIG-BAG PLACED DEEPER ON THE FUNNEL FOR LIFTING HIGH
- DIMENSIONI BOCCA DI SCARICO
DISCHARGE DIMENSIONS 680x680 mm

QUOTE SEDI FORCHE INTERNE | INTERNAL FORK SEATS DIMENSIONS

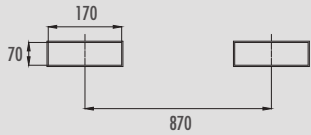

// CONTENITORE PORTA "BIG-BAG" VERNICIATO
VARNISHED "BIG-BAG" CONTAINER

MODELLO MODEL	DIMENSIONI DIMENSIONS mm			PORTATA LOAD CAPACITY kg
	L	P	H	
873PB15	1070	1070	1350	1000

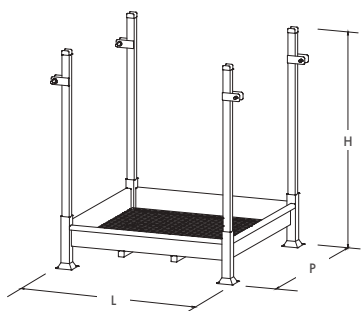

- Con piantane smontabili dotate di agganci
With removable planks with hooks

// CONTENITORE PORTA "BIG-BAG" ZINCATO
ZINC-COATED "BIG-BAG" CONTAINER

MODELLO MODEL	DIMENSIONI DIMENSIONS mm			PORTATA LOAD CAPACITY kg
	L	P	H	
873PB15Z	1070	1070	1350	1000

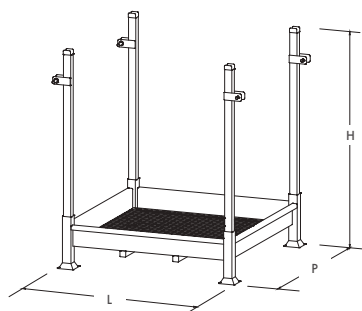

- Con piantane smontabili dotate di agganci
With removable planks with hooks

// CONTENITORE PORTA "BIG-BAG" CON VASCA
"BIG-BAG" SUPPORT WITH TANK

MODELLO MODEL	DIMENSIONI DIMENSIONS mm			PORTATA LOAD CAPACITY kg
	L	P	H	
873VB15	1060	1060	1930	1000

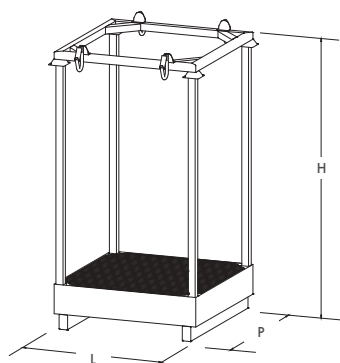

- Grigliato zincato
Galvanized grid
- Con telaio e piantane smontabili
With removable frame and planks

////// BILANCINO PORTA "BIG-BAG" CON SEDI FORCHE
 "BIG-BAG" LIFTING BEAM WITH FORK SEATS

MODELLO MODEL	DIMENSIONI ESTERNE EXTERNAL DIMENSIONS mm			PORTATA LOAD CAPACITY kg
	L	P	H	
564SBX	1070	1160	350	2000

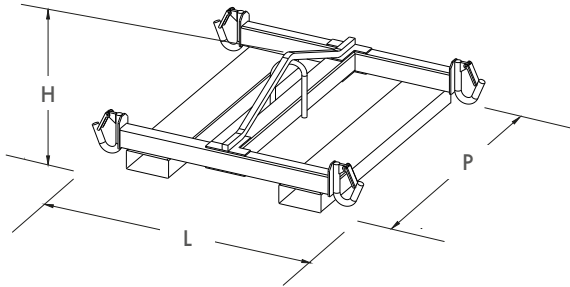

////// QUOTE SEDI FORCHE INTERNE | INTERNAL FORK SEATS DIMENSIONS

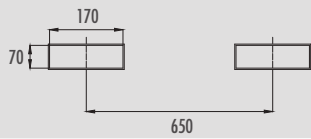

////// SACCO "BIG-BAG" OMOLOGATO
 "BIG-BAG" APPROVED

MODELLO MODEL	DIMENSIONI DIMENSIONS mm			PORTATA LOAD CAPACITY kg
	L	P	H	
99C30-	900	900	1000 1200 1500 1700	1000 1200 1500 2000



////// DISPENSER DOSBAG PER LO SCARICO DEL "BIG-BAG"
 DOSBAG DISPENSER FOR UNLOADING THE "BIG-BAG"

MODELLO MODEL	DIMENSIONI DIMENSIONS mm		FLUSSO FLOW kg/min
	Ø	P	
99C383	150	430	150/200



// CARRELLO COMPONIBILE NEW TRIS
NEW TRIS MODULAR CART

• Forniti smontati
Provided dismantled

MODELLO MODEL	DIMENSIONI DIMENSIONS mm			PORTATA PER OGNI PIANO LOAD CAPACITY FOR EVERY TOP kg	PORTATA LOAD CAPACITY kg
	L	P	H		
943SM mini	800	440	870	65	195
944SM maxi	900	600	870	100	300

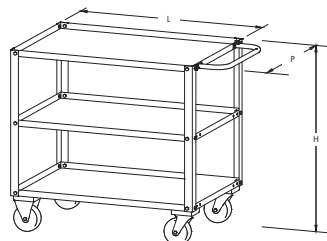

// CARRELLO COMPONIBILE TRIS SUPER MAXI
TRIS SUPER MAXI MODULAR CART

• Regolabile in altezza
Adjustable in height

MODELLO MODEL	DIMENSIONI DIMENSIONS mm			PORTATA PIANO SUPERIORE UPPER TOP LOAD CAPACITY kg
	L	P	H	
944PR	1260	860	800/1015	2000

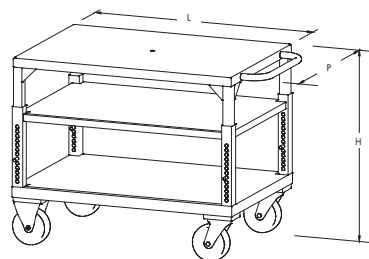

// CARRELLO SGOCCIOLATORE
DRAINING TANK

MODELLO MODEL	DIMENSIONI DIMENSIONS mm			VOLUME lit
	L	P	H	
940	810	410	960	70

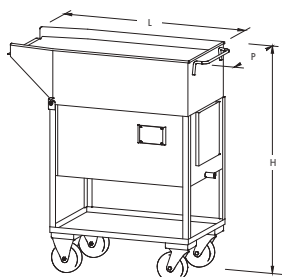



La legge (Rif. D.M. 392 16/05/1996 per oli e D.M. 18/05/1995 per depositi di soluzioni idroalcoliche, deliberazione del 27/07/1984) dice che i bacini di contenimento devono contenere il maggiore fra:

The law (Ref D.M. 392 16/05/1996 for oils and D.M. 18/05/1995 for deposits of hydroalcoholic solutions, deliberation of 27/07/1984) says that the containment basins must contain the largest of:

IL VOLUME DEL CONTENITORE PIÙ GRANDE STOCCATO SULLA VASCA
THE VOLUME OF THE LARGEST CONTAINER STORED ON THE SPILL CONTAINMENT PALLET

E
AND

1/3 DEL LIQUIDO TOTALE STOCCATO
1/3 OF THE TOTAL OF THE LIQUID STORED

ESEMPIO 1
EXAMPLE 1

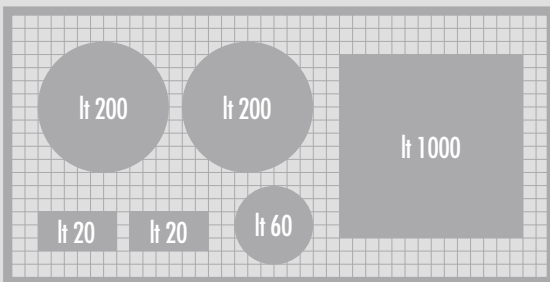

TOTALE LITRI STOCCATI 1500 quindi $1500 \times 1/3 = 500$ LITRI
 TOTAL LITERS STORED 1500 therefore $1500 \times 1/3 = 500$ LITERS

CONTENITORE PIÙ GRANDE STOCCATO: 1000 LITRI
 LARGEST CONTAINER STORED: 1000 LITER

1000 lt > 500 lt

QUINDI LA VASCA **DOVRÀ CONTENERE 1000 LITRI**
 in quanto è il risultato maggiore tra i due
THEREFORE THE SPILL CONTAINMENT PALLET HAS TO CONTAIN 1000 LITERS since it is the greater result between the two

ESEMPIO 2
EXAMPLE 2

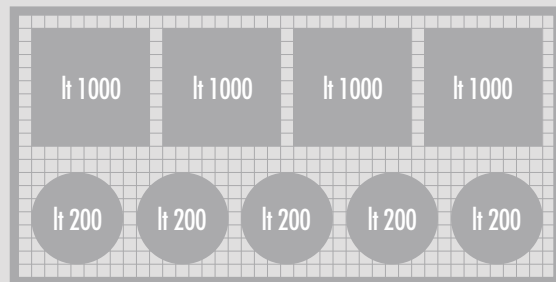

TOTALE LITRI STOCCATI 5000 quindi $5000 \times 1/3 = 1667$ LITRI
 TOTAL LITERS STORED 5000 therefore $5000 \times 1/3 = 1667$ LITERS

CONTENITORE PIÙ GRANDE STOCCATO: 1000 LITRI
 LARGEST CONTAINER STORED: 1000 LITER

1000 lt < 1667 lt

QUINDI LA VASCA **DOVRÀ CONTENERE 1667 LITRI**
 in quanto è il risultato maggiore tra i due
THEREFORE THE SPILL CONTAINMENT PALLET HAS TO CONTAIN 1667 LITERS since it is the greater result between the two

VASCA DI CONTENIMENTO IN ACCIAIO PER 1 FUSTO
STEEL SPILL CONTAINMENT PALLET FOR 1 DRUM

MODELLO MODEL	DIMENSIONI DIMENSIONS mm			CAPACITÀ DI STOCCAGGIO STORAGE CAPACITY	VOLUME lt
	L	P	H		
821E	850	850	400	1 fusto da 200 lt su grigliato 1x200 lt drum on grid	205

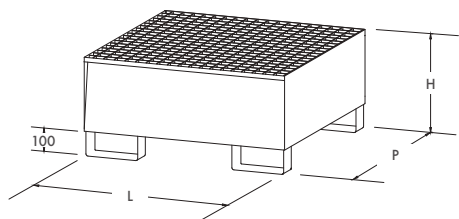

- Grigliato zincato a caldo
Hot-dip galvanized grid

VASCA DI CONTENIMENTO IN ACCIAIO PER 1 FUSTO CON RUOTE
STEEL SPILL CONTAINMENT PALLET FOR 1 DRUM WITH WHEELS

MODELLO MODEL	DIMENSIONI DIMENSIONS mm					CAPACITÀ DI STOCCAGGIO STORAGE CAPACITY	VOLUME lt
	L	P	H	H1	H2		
821ER	850	850	480	1030	155	1 fusto da 200 lt su grigliato 1x200 lt drum on grid	205

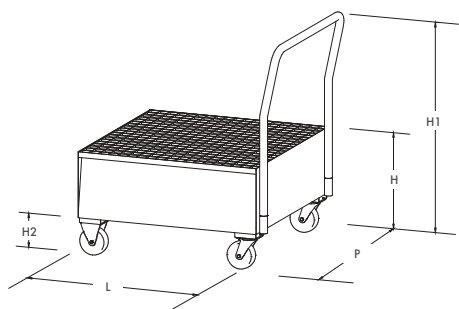

- Grigliato zincato a caldo
Hot-dip galvanized grid
- Ruote girevoli con freno
Rotating wheels with brake
- Maniglione
Handle

VASCA DI CONTENIMENTO IN ACCIAIO PER 2 FUSTI
STEEL SPILL CONTAINMENT PALLET FOR 2 DRUMS

MODELLO MODEL	DIMENSIONI DIMENSIONS mm			CAPACITÀ DI STOCCAGGIO STORAGE CAPACITY	VOLUME lt
	L	P	H		
822E	1340	850	330	2 fusti da 200 lt su grigliato 2x200 lt drums on grid	230

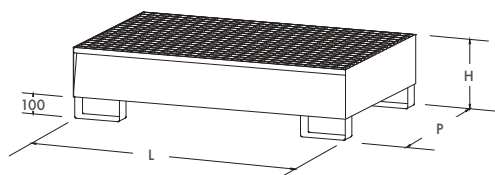
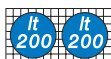

- Grigliato zincato a caldo
Hot-dip galvanized grid

VASCA DI CONTENIMENTO IN ACCIAIO PER 2 FUSTI CON RUOTE
STEEL SPILL CONTAINMENT PALLET FOR 2 DRUMS WITH WHEELS

MODELLO MODEL	DIMENSIONI DIMENSIONS mm					CAPACITÀ DI STOCCAGGIO STORAGE CAPACITY	VOLUME lt
	L	P	H	H1	H2		
822ER	1340	850	410	1030	155	2 fusti da 200 lt su grigliato 2x200 lt drums on grid	230

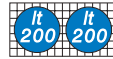
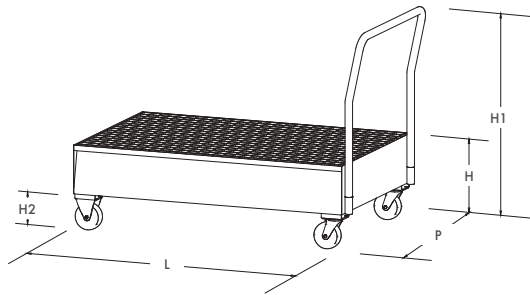

- Grigliato zincato a caldo
Hot-dip galvanized grid
- Ruote girevoli con freno
Rotating wheels with brake
- Maniglione
Handle



VASCA DI CONTENIMENTO PER 4 FUSTI
SPILL CONTAINMENT PALLET FOR 4 DRUMS

MODELLO MODEL	DIMENSIONI DIMENSIONS mm			CAPACITÀ DI STOCCAGGIO STORAGE CAPACITY	VOLUME lt
	L	P	H		
824E	1340	1250	300	4 fusti da 200 lt su grigliato 4x200 lt drums on grid	280

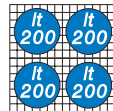
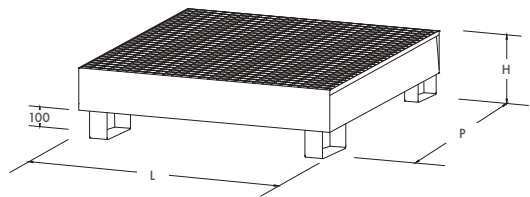

- Grigliato zincato a caldo
Hot-dip galvanized grid



VASCA DI CONTENIMENTO PER 4 FUSTI
SPILL CONTAINMENT PALLET FOR 4 DRUMS

MODELLO MODEL	DIMENSIONI DIMENSIONS mm			CAPACITÀ DI STOCCAGGIO STORAGE CAPACITY	VOLUME lt
	L	P	H		
8080V4F	2660	855	400	4 fusti da 200 lt su grigliato 4x200 lt drums on grid	600

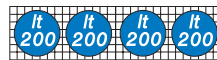
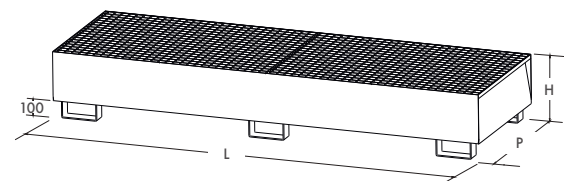

- Grigliato zincato a caldo
Hot-dip galvanized grid
- Disposizione dei fusti in orizzontale
Drums arranged horizontally



VASCA DI CONTENIMENTO IN ACCIAIO PER 1 CISTERNETTA
STEEL SPILL CONTAINMENT PALLET FOR 1 TANK

MODELLO MODEL	DIMENSIONI DIMENSIONS mm			CAPACITÀ DI STOCCAGGIO STORAGE CAPACITY	VOLUME lt
	L	P	H		
826STQ	1350	1650	640	1 cisternetta da 1000 lt su grigliato 1x1000 lt tank on grid	1000

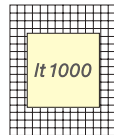
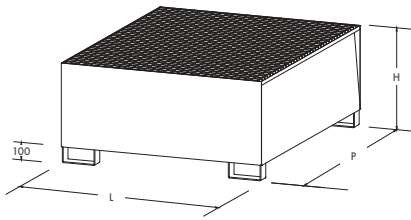

• Grigliato zincato a caldo
Hot-dip galvanized grid

TREPOLO PER VASCA DI CONTENIMENTO IN ACCIAIO PER 1 CISTERNETTA
STEEL STAND FOR SPILL CONTAINMENT PALLET FOR 1 TANK

MODELLO MODEL	DIMENSIONI DIMENSIONS mm						CAPACITÀ DI STOCCAGGIO STORAGE CAPACITY	VOLUME lt
	L	P1	P2	H1	H2	H3		
826STQ vasca tank 99C434 trespolo stand	1350	1650	1265	1105	640	465	1 cisternetta da 1000 lt su grigliato 1x1000 lt tank on grid	1000

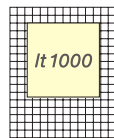
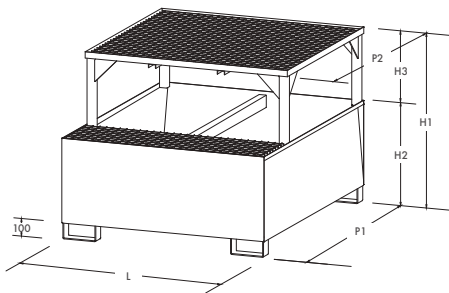

• Grigliato zincato a caldo
Hot-dip galvanized grid

VASCA DI CONTENIMENTO IN ACCIAIO PER 2 CISTERNETTE
STEEL SPILL CONTAINMENT PALLET FOR 2 TANKS

MODELLO MODEL	DIMENSIONI DIMENSIONS mm			CAPACITÀ DI STOCCAGGIO STORAGE CAPACITY	VOLUME lt
	L	P	H		
8080V2C	2660	1250	450	2 cisternette da 1000 lt su grigliato 2x1000 lt tanks on grid	1100

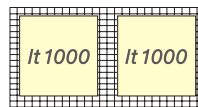
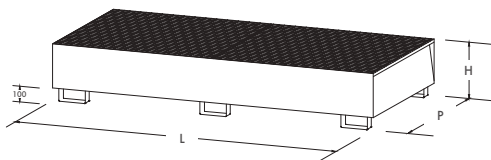

• Grigliato zincato a caldo
Hot-dip galvanized grid

ACCESSORI | ACCESSORIES



CISTERNETTA
TANK



POMPA
PORTATA 40 LT
PUMP
FLOW RATE 40 LT



RIDUZIONE IN ALLUMINIO
CON RUBINETTO DA 1"
ALLUMINIUM REDUCTION
WITH 1" DISCHARGE VALVE

VASCA DI CONTENIMENTO IN ACCIAIO PER 2 CISTERNETTE
STEEL SPILL CONTAINMENT PALLET FOR 2 TANKS

MODELLO MODEL	DIMENSIONI DIMENSIONS mm			CAPACITÀ DI STOCCAGGIO STORAGE CAPACITY	VOLUME lt
	L	P	H		
8070V2C	2720	1650	350	2 cisternette da 1000 lt su grigliato 2x1000 lt tanks on grid	1000

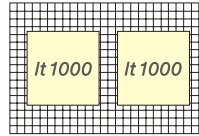
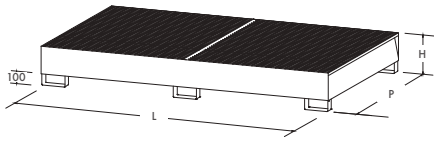

- Grigliato zincato a caldo
Hot-dip galvanized grid
- Profondità della vasca
maggiorata
Increased depth of
the tank

TREPOLO PER VASCA DI CONTENIMENTO IN ACCIAIO PER 2 CISTERNETTE
STEEL STAND FOR SPILL CONTAINMENT PALLET FOR 2 TANKS

MODELLO MODEL	DIMENSIONI DIMENSIONS mm						CAPACITÀ DI STOCCAGGIO STORAGE CAPACITY	VOLUME lt
	L	P1	P2	H1	H2	H3		
8070V2C vasca tank 2x99C434 trespolo stand	2720	1650	1265	815	350	465	2 cisternette da 1000 lt su grigliato 2x1000 lt tanks on grid	1000

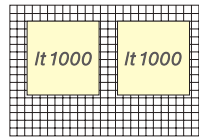
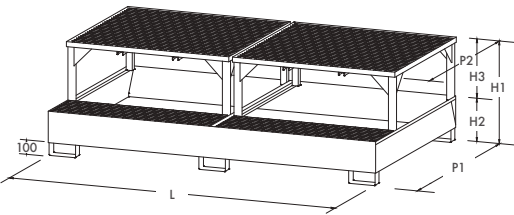

- Grigliato zincato a caldo
Hot-dip galvanized grid

VASCA DI CONTENIMENTO IN ACCIAIO PER 3 CISTERNETTE
STEEL SPILL CONTAINMENT PALLET FOR 3 TANKS

MODELLO MODEL	DIMENSIONI DIMENSIONS mm			CAPACITÀ DI STOCCAGGIO STORAGE CAPACITY	VOLUME lt
	L	P	H		
8070V3CX	3280	1350	350	3 cisternette da 1000 lt su grigliato 3x1000 lt tanks on grid	1050

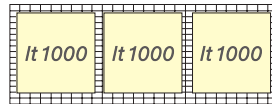
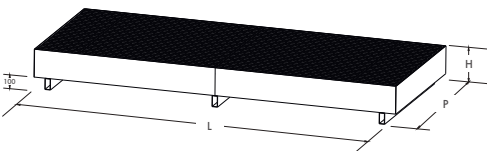

- Grigliato zincato a caldo
Hot-dip galvanized grid

ACCESSORI | ACCESSORIES



CISTERNETTA
TANK



POMPA
PORTATA 40 LT
PUMP
FLOW RATE 40 LT



RIDUZIONE IN ALLUMINIO
CON RUBINETTO DA 1"
ALLUMINIUM REDUCTION
WITH 1" DISCHARGE VALVE

VASCA IN ACCIAIO PER SCAFFALATURA PER 4 CISTERNETTE O 16/24 FUSTI
STEEL TANK FOR SHELVING FOR 4 TANKS OR 16/24 DRUMS

• SCAFFALATURE
SHELVING
PG. 40-41

• Grigliato zincato a caldo
Hot-dip galvanized grid

MODELLO MODEL	DIMENSIONI DIMENSIONS mm			VOLUME lit
	L	P	H	
8080V4C	2660	1250	600	1600

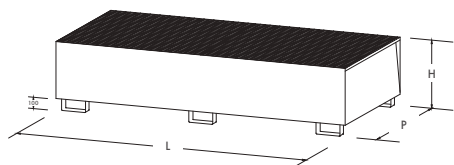

VASCA IN ACCIAIO PER SCAFFALATURA PER 6 CISTERNETTE
STEEL TANK FOR SHELVING FOR 6 TANKS

• SCAFFALATURE
SHELVING
PG. 40-41

• Grigliato zincato a caldo
Hot-dip galvanized grid

MODELLO MODEL	DIMENSIONI DIMENSIONS mm			VOLUME lit
	L	P	H	
8080V6C	3565	1250	610	2050

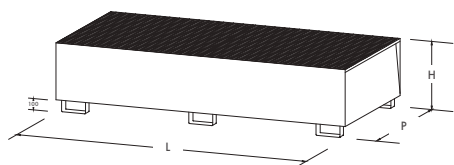

FUSTI METALLICI CILINDRICI OMOLOGATI
HOMOLOGATED CYLINDRICAL METAL DRUMS

MODELLO MODEL	TIPO TYPE	COPERCHIO COVER	TAPPI CAPS	VOLUME lit
813FL217	Isocontainer senza corrugazioni Isocontainer without corrugations	Fisso Fixed	Uno da 2" e uno da 3/4" One 2" and one 3/4"	217
813FL217CM	Manto con corrugazioni Mantle with corrugations	Removibile Removable	Senza tappi Without caps	217



CISTERNA MULTIUSO PER STOCCAGGIO ACQUA POTABILE O LIQUIDI VARI
MULTI-PURPOSE TANK FOR STORAGE OF DRINKABLE WATER OR VARIOUS LIQUIDS

• Robusto supporto in plastica
Sturdy plastic holder

• Possibilità di acquisto di modelli rigenerati
Possibility of purchasing regenerated models

MODELLO MODEL	DIMENSIONI DIMENSIONS mm			TARA TARE kg	VOLUME lit
	L	P	H		
614	1000	1200	1165	56	1000
614RI rigenerata regenerated	1000	1200	1165	56	1000

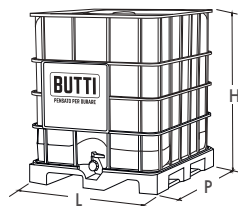

ACCESSORI | ACCESSORIES



POMPA
PORTATA 40 LT
PUMP
FLOW RATE 40 LT



RIDUZIONE IN ALLUMINIO
CON RUBINETTO DA 1"
ALLUMINIUM REDUCTION
WITH 1" DISCHARGE VALVE

VASCHE IN POLIETILENE PER PICCOLI CONTENITORI
POLYETHYLENE TANKS FOR SMALL CONTAINERS

MODELLO MODEL	DIMENSIONI DIMENSIONS mm			VOLUME lt
	L	P	H	
83PL0045	630	590	170	45
83PL0280	1230	830	300	280 pallettizzabile forklift pockets



VASCA DI CONTENIMENTO IN POLIETILENE PER FUSTI PER SOSTANZE ACIDE
POLYETHYLENE SPILL CONTAINMENT PALLET FOR DRUMS FOR ACID SUBSTANCES

MODELLO MODEL	DIMENSIONI DIMENSIONS mm			CAPACITÀ DI STOCCAGGIO STORAGE CAPACITY	VOLUME lt
	L	P	H		
8070V1FP	925	800	420	1 fusto da 200 lt su grigliato 1x200 lt drum on grid	225
83PL0305	1350	800	420	2 fusti da 200 lt su grigliato 2x200 lt drums on grid	305
824EP	1350	1350	490	4 fusti da 200 lt su grigliato 4x200 lt drums on grid	500

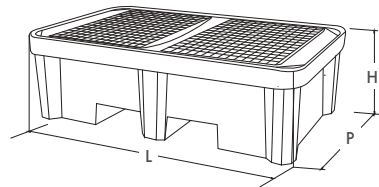
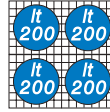
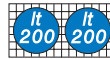

VASCA DI CONTENIMENTO IN POLIETILENE PER CISTERNETTA PER SOSTANZE ACIDE
POLYETHYLENE SPILL CONTAINMENT PALLET FOR TANK FOR ACID SUBSTANCES

MODELLO MODEL	DIMENSIONI DIMENSIONS mm			CAPACITÀ DI STOCCAGGIO STORAGE CAPACITY	VOLUME lt
	L	P	H		
826STQP	1350	1350	970	1 cisternetta da 1000 lt su grigliato 1x1000 lt tank on grid	1050

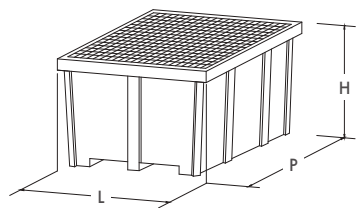
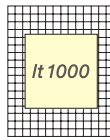

VASCA DI CONTENIMENTO IN POLIETILENE PER 2 CISTERNETTE PER SOSTANZE ACIDE
POLYETHYLENE SPILL CONTAINMENT PALLET FOR 2 TANKS FOR ACID SUBSTANCES

MODELLO MODEL	DIMENSIONI DIMENSIONS mm			CAPACITÀ DI STOCCAGGIO STORAGE CAPACITY	VOLUME lt
	L	P	H		
8070V2CP	2540	1370	650	2 cisternette da 1000 lt su grigliato 2x1000 lt tanks on grid	1150

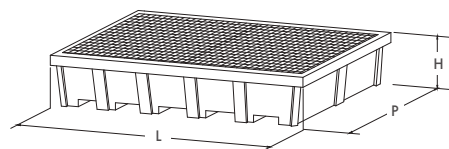
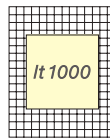

SUPPORTO PER LO STOCCAGGIO DI UN FUSTO IN ORIZZONTALE
SUPPORT FOR STORING A DRUM HORIZONTALLY

MODELLO MODEL	DIMENSIONI DIMENSIONS mm			CAPACITÀ DI STOCCAGGIO STORAGE CAPACITY	PORTATA LOAD CAPACITY kg
	L	P	H		
801	880	785	910	1 fusto da 200 lt 1x200 lt drum	300

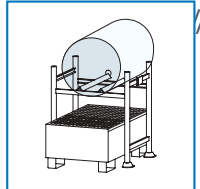
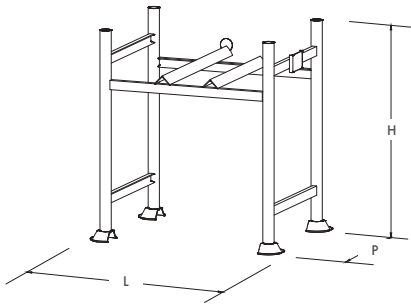

• I supporti sono sovrapponibili
The supports are stackable

• Grigliato zincato a caldo
Hot-dip galvanized grid

VASCA DI CONTENIMENTO IN ACCIAIO PER SUPPORTO A UN FUSTO
STEEL SPILL CONTAINMENT PALLET FOR ONE DRUM SUPPORT

MODELLO MODEL	DIMENSIONI DIMENSIONS mm			PORTATA LOAD CAPACITY kg
	L	P	H	
801VG	635	1065	420	205

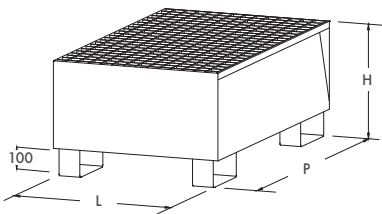

SUPPORTO PER LO STOCCAGGIO DI DUE FUSTI IN ORIZZONTALE
SUPPORT FOR STORING TWO DRUMS HORIZONTALLY

MODELLO MODEL	DIMENSIONI DIMENSIONS mm			CAPACITÀ DI STOCCAGGIO STORAGE CAPACITY	PORTATA LOAD CAPACITY kg
	L	P	H		
802	1480	785	910	2 fusti da 200 lt 2x200 lt drums	600

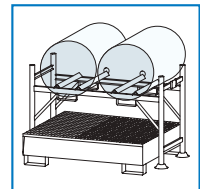
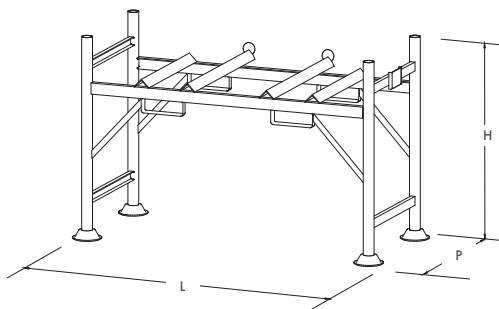

• I supporti sono sovrapponibili
The supports are stackable

• Grigliato zincato a caldo
Hot-dip galvanized grid

VASCA DI CONTENIMENTO IN ACCIAIO PER SUPPORTO A DUE FUSTI
STEEL SPILL CONTAINMENT PALLET FOR TWO DRUMS SUPPORT

MODELLO MODEL	DIMENSIONI DIMENSIONS mm			PORTATA LOAD CAPACITY kg
	L	P	H	
802VG	1250	1080	310	270

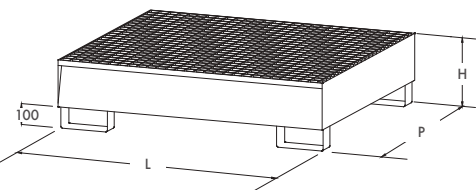

////// DEPOSITO IN ACCIAIO PER 2 O 4 FUSTI
OUTDOOR STEEL CONTAINER FOR 2 OR 4 DRUMS

MODELLO MODEL	DIMENSIONI DIMENSIONS mm			VOLUME lt
	L	P	H	
822GB15	1350	860	1570	262
824GB15	1350	1260	1540	340

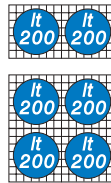

////// DEPOSITO IN ACCIAIO PER 1 CISTERNETTA
OUTDOOR STEEL CONTAINER FOR 1 TANK

MODELLO MODEL	DIMENSIONI DIMENSIONS mm			VOLUME lt
	L	P	H	
8080D1C18	1350	1660	1810	1100

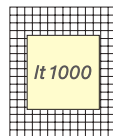

////// DEPOSITO IN POLIETILENE PER 1 CISTERNETTA
POLYETHYLENE OUTDOOR CONTAINER FOR 1 TANK

MODELLO MODEL	DIMENSIONI DIMENSIONS mm			VOLUME lt
	L	P	H	
8080AP1C	1540	1600	2360	1100

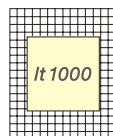

ACCESSORI | ACCESSORIES //



//////
CISTERNETTA
TANK



//////
POMPA
PORTATA 40 LT
PUMP
FLOW RATE 40 LT



//////
RIDUZIONE IN ALLUMINIO
CON RUBINETTO DA 1"
ALLUMINIUM REDUCTION
WITH 1" DISCHARGE VALVE



SCAFFALATURE ANTISISMICHE BUTTI, ROBUSTE E RESISTENTI

- ✓ progettate per resistere alle azioni sismiche su tutto il territorio italiano e realizzate con le migliori materie prime
- ✓ dotate di controventature posteriori e robusti montanti con tralicciatura saldata
- ✓ semplici e pratiche da montare: offrono praticità e sicurezza in tutti i settori di utilizzo

// SCAFFALATURA CON VASCA PER 16 FUSTI DA 200 LT IN VERTICALE SHELVING WITH SPILL CONTAINMENT PALLET FOR 16 DRUMS WITH 200 LT CAPACITY VERTICALLY

MODELLO MODEL	DIMENSIONI DIMENSIONS mm			VOLUME lt
	L	P	H	
808016FMA	2900	1400	2950	1600

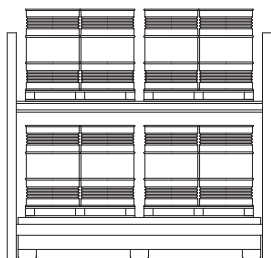

• VASCHE DI CONTENIMENTO
SPILL CONTAINMENT PALLET
PG. 36



// SCAFFALATURA CON VASCA PER 24 FUSTI DA 200 LT IN VERTICALE SHELVING WITH SPILL CONTAINMENT PALLET FOR 24 DRUMS WITH 200 LT CAPACITY VERTICALLY

MODELLO MODEL	DIMENSIONI DIMENSIONS mm			VOLUME lt
	L	P	H	
808024FMA	2900	1400	3950	1600

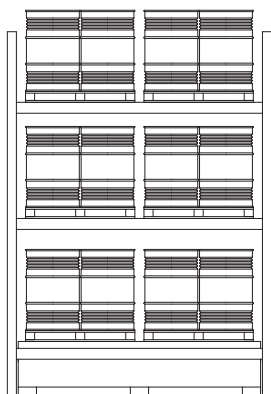

• VASCHE DI CONTENIMENTO
SPILL CONTAINMENT PALLET
PG. 36

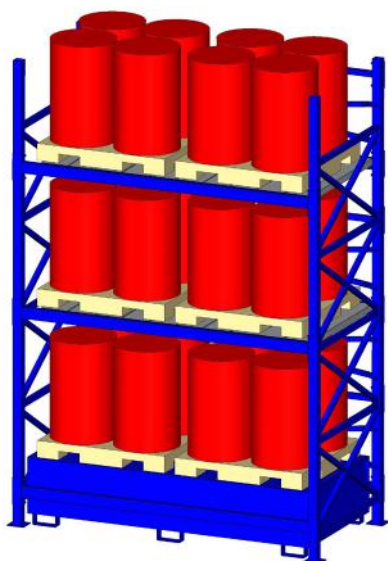

BUTTI ANTI-SEISMIC SHELVING, ROBUST AND RESISTANT

- ✓ designed to withstand seismic actions throughout the whole Italian territory and made with the best raw materials
- ✓ equipped with scaffolding frame cross braces and sturdy uprights with welded trellis
- ✓ simple and practical to assemble: they offer practicality and safety in all sectors



SCAFFALATURA CON VASCA PER 4 CISTERNETTE DA 1000 LT SHELVING WITH SPILL CONTAINMENT PALLET FOR 4 1000 LT TANKS

MODELLO MODEL	DIMENSIONI DIMENSIONS mm			VOLUME li
	L	P	H	
80804CMA	2900	1400	2950	1600

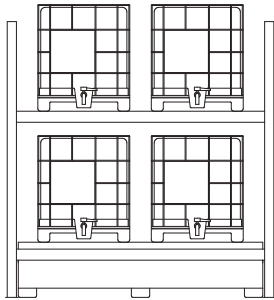

- VASCHE DI CONTENIMENTO
SPILL CONTAINMENT PALLET
PG. 36



SCAFFALATURA CON VASCA PER 6 CISTERNETTE DA 1000 LT SHELVING WITH SPILL CONTAINMENT PALLET FOR 6 1000 LT TANKS

MODELLO MODEL	DIMENSIONI DIMENSIONS mm			VOLUME li
	L	P	H	
80806CMA	3800	1400	2950	2050

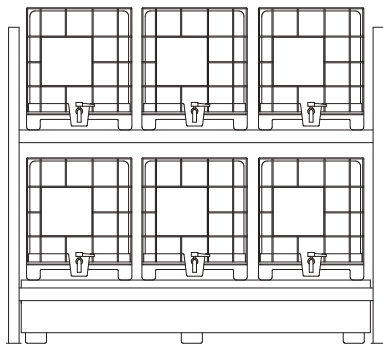

- VASCHE DI CONTENIMENTO
SPILL CONTAINMENT PALLET
PG. 36



// PINZA PER FUSTI IN ORIZZONTALE E VERTICALE
DRUM GRIPPER FOR HORIZONTAL AND VERTICAL LIFTING

MODELLO MODEL	PORTATA LOAD CAPACITY kg
927A0	350



• Pinza per la presa di fusti orizzontali e verticali. Robusta costruzione con catena e ganci speciali per la presa del fusto
Horizontal and vertical drum gripper. Sturdy construction with chain and special hooks to grab the drum

// PINZA PER FUSTI IN VERTICALE
DRUM GRIPPER FOR VERTICAL DRUM LIFTING

MODELLO MODEL	CAPACITÀ DI STOCCAGGIO STORAGE CAPACITY	NUMERO BRACCI NUMBER OF ARMS	PORTATA LOAD CAPACITY kg
927AV	1 fusto da 200 lt 1x200 lt drum	2	350
927AV3	1 fusto da 200 lt 1x200 lt drum	3	350



• Pinza per il sollevamento di fusti in verticale costruita in acciaio che permette la movimentazione dei fusti in totale sicurezza
Gripper for vertical drum lifting made of steel for the safely handling of drums

// RIBALTATORE INFORCABILE PER FUSTO
FORKABLE DRUMS DUMPER

MODELLO MODEL	CAPACITÀ DI STOCCAGGIO STORAGE CAPACITY	PORTATA LOAD CAPACITY kg
927G	1 fusto da 200 lt 1x200 lt drum	350



• Ribaltatore per fusti con sistema sicuro e funzionamento semplice tramite volantino e catena. Permette di ruotare il fusto fino a 360° mediante riduttore manuale
Drum dumper with a safe and simple operation with handwheel and chain. Rotates up to 360° by manual reduction gear

// QUOTE SEDI FORCHE INTERNE | INTERNAL FORK SEATS DIMENSIONS

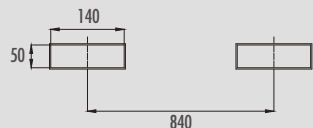

// PINZA INFORCABILE PER UN FUSTO
FORKABLE GRIPPER FOR ONE DRUM

MODELLO MODEL	DIMENSIONI DIMENSIONS mm			CAPACITÀ DI STOCCAGGIO STORAGE CAPACITY	PORTATA LOAD CAPACITY kg
	L	P	H		
927P1	1220	670	130	1 fusto da 200 lt 1x200 lt drum	300



YOUTUBE VIDEO

• Pinza per un fusto in acciaio con azione di presa automatica del fusto che viene sollevato, trasportato e deposto automaticamente senza che l'operatore debba scendere dal carrello elevatore
Gripper for steel drums with automatic grab system. The drum can be lifted, moved and put down automatically without having driver to leave the seat

// QUOTE SEDI FORCHE INTERNE | INTERNAL FORK SEATS DIMENSIONS

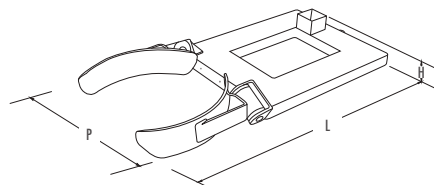
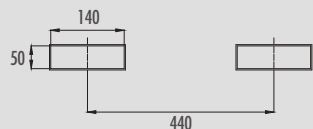

// CARRELLO PORTA FUSTO
DRUM TROLLEY

MODELLO MODEL	DIMENSIONI DIMENSIONS mm			CAPACITÀ DI STOCCAGGIO STORAGE CAPACITY	PORTATA LOAD CAPACITY kg
	L	P	H		
938PF1	1020	630	120	1 fusto da 200 lt 1x200 lt drum	250



• Il carrello porta fusto permette una facile presa per fusti da 200 litri ed è equipaggiato con un dispositivo di bloccaggio. È idoneo anche come stazione di travaso
The drum trolley allows an easy handling of 200-liter capacity drums and is equipped with a locking device. It is also suitable as a transfer station

////// PINZA A BECCO "ECO" INFORCABILE PER UN FUSTO
"ECO" FORKLIFT DRUM MOVER FOR ONE DRUM

MODELLO MODEL	DIMENSIONI DIMENSIONS mm			CAPACITÀ DI STOCCAGGIO STORAGE CAPACITY	PORTATA LOAD CAPACITY kg
	L	P	H		
927B1E	850	590	800	1 fusto da 200 lt 1x200 lt drum	350



////// QUOTE SEDI FORCHE INTERNE | INTERNAL FORK SEATS DIMENSIONS

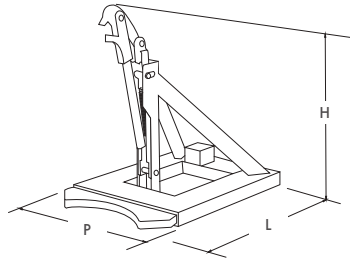
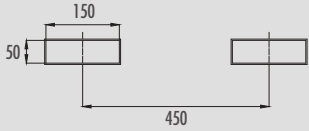

• Pinza a becco inforcabile per la movimentazione di un fusto in metallo con bordo superiore. Le operazioni di aggancio e sgancio vengono effettuate dall'operatore alla guida
Flat nose gripper for the handling of a metal drum with upper edge. Hook and release operations are carried out by the driver

////// PINZA A BECCO INFORCABILE PER UN FUSTO
FORKLIFT DRUM MOVER FOR ONE DRUM

MODELLO MODEL	DIMENSIONI DIMENSIONS mm			CAPACITÀ DI STOCCAGGIO STORAGE CAPACITY	PORTATA LOAD CAPACITY kg
	L	P	H		
927B1	1105	605	850	1 fusto da 200 lt 1x200 lt drum	350



////// QUOTE SEDI FORCHE INTERNE | INTERNAL FORK SEATS DIMENSIONS

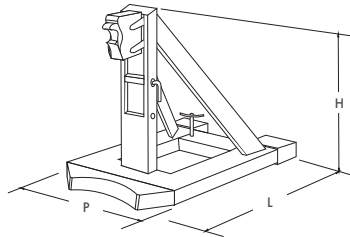
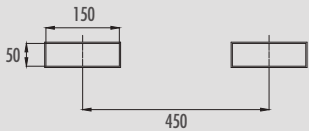

• Sistema di trasporto monofusto. Massima sicurezza grazie al sistema che fa presa sul fusto anche su superfici non perfettamente piane. Le operazioni di aggancio e sgancio vengono effettuate dall'operatore alla guida
System to transport single drums without damages. Maximum safety due to the grip system that grabs also drums with not perfectly flat surfaces. Hook and release operations are carried out by the driver

////// PINZA A BECCO INFORCABILE PER DUE FUSTI
FORKLIFT DRUM MOVER FOR TWO DRUMS

MODELLO MODEL	DIMENSIONI DIMENSIONS mm			CAPACITÀ DI STOCCAGGIO STORAGE CAPACITY	PORTATA LOAD CAPACITY kg
	L	P	H		
927B2	1105	1030	855	2 fusti da 200 lt 2x200 lt drums	700



////// QUOTE SEDI FORCHE INTERNE | INTERNAL FORK SEATS DIMENSIONS

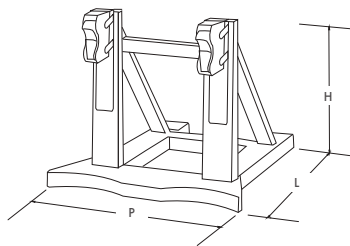

• Sistema di trasporto di due fusti che ne evita il danneggiamento. Massima sicurezza grazie al sistema che fa presa sul fusto anche su superfici non perfettamente piane. Le operazioni di aggancio e sgancio vengono effettuate dall'operatore alla guida
System to transport two drums without damages. Maximum safety thanks to the grip system that grabs also drums with not perfectly flat surfaces. Hook and release operations are carried out by the driver

////// PINZA A BECCO INFORCABILE PER UN FUSTO IN PLASTICA
FORKLIFT DRUM MOVER FOR ONE PLASTIC DRUM

MODELLO MODEL	DIMENSIONI DIMENSIONS mm			CAPACITÀ DI STOCCAGGIO STORAGE CAPACITY	PORTATA LOAD CAPACITY kg
	L	P	H		
9271FP	1180	600	830	1 fusto di plastica diametro min. 350mm max. 650mm 1 plastic drum diameter min. 350mm max. 650	800



////// QUOTE SEDI FORCHE INTERNE | INTERNAL FORK SEATS DIMENSIONS

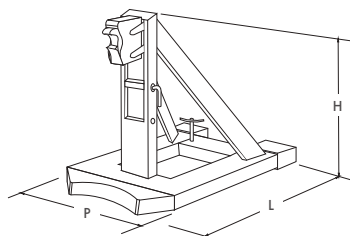
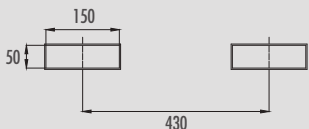

• Pinza a becco inforcabile per la presa sul bordo superiore di un fusto in plastica con coperchio estraibile. Interamente trattata antiusura e anticorrosione in ogni suo componente. Le operazioni di aggancio e sgancio vengono effettuate dall'operatore alla guida
Flat nose gripper for the handling of a plastic drum with removable lid. Fully treated anti-wear and anti-corrosion in each of its components. Hook and release operations are carried out by the driver

// GANCIO DI CARICO
LIFTING HOOK

MODELLO MODEL	DIMENSIONI DIMENSIONS mm			PORTATA LOAD CAPACITY kg
	L	P	H	
921	630	250	250	2000

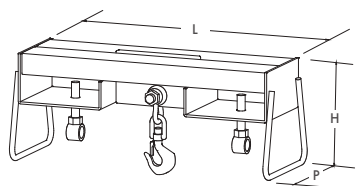

// QUOTE SEDI FORCHE INTERNE | INTERNAL FORK SEATS DIMENSIONS

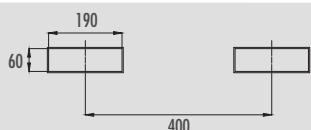

// GANCIO DI CARICO
LIFTING HOOK

MODELLO MODEL	DIMENSIONI DIMENSIONS mm			PORTATA LOAD CAPACITY kg
	L	P	H	
921Q40	1025	320	400	4000

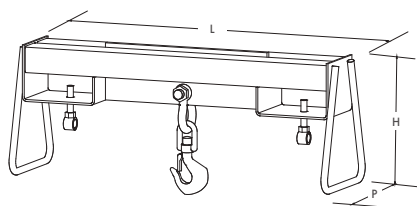

// QUOTE SEDI FORCHE INTERNE | INTERNAL FORK SEATS DIMENSIONS

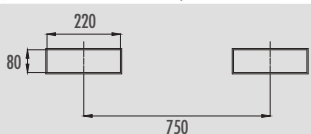

// TAVOLA ELEVATRICE
LIFTING TABLE

MODELLO MODEL	DIMENSIONI DIMENSIONS mm			CORSA UTILE USEFUL SLIDING mm	POTENZA MOTORE ENGINE POWER hp	TENSIONE DI ALIMENTAZIONE SUPPLY VOLTAGE volt	CILINDRI CYLINDERS nr Ø cf	TEMPO DI SALITA CLIMB TIME sec	PRESSIONE DI ESERCIZIO OPERATING PRESSURE atm	TARA TARE kg	PORTATA LOAD CAPACITY kg
	LxP pianale top	H chiusa closed	H totale total								
716AE20	1500x800	280	1210	930	930	380V - 50 Hz trifase three-phase	1 100 440	40	340	340	2000



//// FORCA GRUCAR
GRUCAR CRANE FORKS

MODELLO MODEL	DIMENSIONI DIMENSIONS mm					TARA TARE kg	PESO PIENO CARICO TOTAL FULL LOAD WEIGHT kg	PORTATA LOAD CAPACITY kg
	L	P	H1	H2	G			
681F202	515/1000	1170	1630/2180	1050/1600	1000	148	2148	2000
681F252	515/1000	1170	1630/2180	1050/1600	1000	155	2655	2500
681F302	570/1000	1210	1730/2290	1085/1645	1000	225	3225	3000



YOUTUBE VIDEO



- Forche forgiate
Forged steel forks



- Sistema di chiusura e raccogliatore catena
Closing system & load binder chain



- Le forche Grukar sono dotate di un supporto per la movimentazione e lo stoccaggio della sola forca (senza carico)
The Grukar forks are equipped with a support for the handling and storage only of the fork (without load)

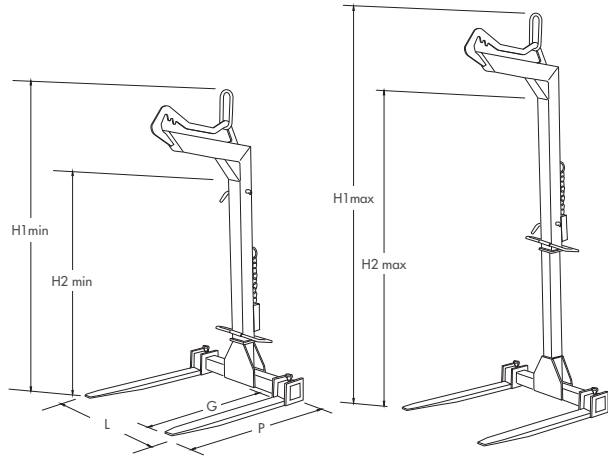

//// FORCHE GRUCAR MOD. AMERICA - AUTOBILANCIATE
GRUCAR CRANE FORKS MOD. AMERICA - SELF-BALANCING

MODELLO MODEL	DIMENSIONI DIMENSIONS mm					TARA TARE kg	PESO PIENO CARICO TOTAL FULL LOAD WEIGHT kg	PORTATA LOAD CAPACITY kg
	L	P	H1	H2	G			
681F252U	565/1000	1375	2085/2920	1375/2210	1200	250	2750	2500

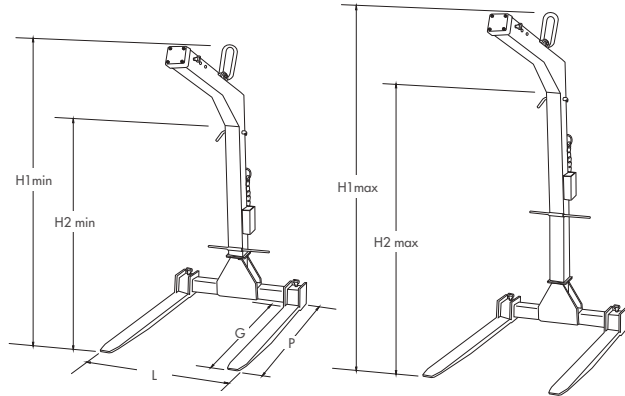

- Sistema di autobilanciamento mod. America
Self-balancing system mod. America

//// COPPIA DI TRAVERSE PER SOLLEVAMENTO
PAIR OF CROSSBEAMS FOR LIFTING

MODELLO MODEL	DIMENSIONI DIMENSIONS mm			PORTATA COPPIA CHARGE IN PAIRS kg
	L	P	H	
849AS10	1280	80	50	2000



- Gancio di presa orientabile
Swivel grip hooks

ACCESSORI | ACCESSORIES



//// ////
CATENA 4 RAMI PER TRAVERSE
4 LEGS CHAIN FOR CROSSBEAMS

MODELLO MODEL	CATENA CHAIN Ø	LUNGHEZZA LENGHT m	PORTATA LOAD CAPACITY kg
594A4	6	4	3000



/// SOTTO GANCI CON GANCI SELF LOCKING
ONE LEG SLINGS WITH SELF LOCKING HOOKS

MODELLO MODEL	CATENA CHAIN Ø	LUNGHEZZA LENGTH m	TARA TARE kg	PORTATA LOAD CAPACITY kg
591D1	10	1	4,8	3150
591F1	13	1	7,3	5300



• GRADO 80
GRADE 80



• Targhetta identificativa
Identification plate

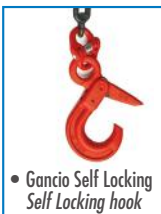

• Gancio Self Locking
Self Locking hook

/// IMBRAGHI A CATENA CON GANCI SELF LOCKING, REGOLABILI CON GANCI ACCORCIATORI
HARNESS CHAINS WITH SELF LOCKING HOOKS, ADJUSTABLE THROUGH SHORTENING HOOKS

MODELLO MODEL	RAMI LEGS nr	CATENA CHAIN Ø	LUNGHEZZA LENGTH m	TARA TARE kg	PORTATA LOAD CAPACITY kg
592B2	2	8	2	9,2	2800
592B25	2	8	2,5	10	2800
592B3	2	8	3	11	2800
592B4	2	8	4	15,2	2800
592B6	2	8	6	20	2800



MODELLO MODEL	RAMI LEGS nr	CATENA CHAIN Ø	LUNGHEZZA LENGTH m	TARA TARE kg	PORTATA LOAD CAPACITY kg
593B2	3	8	2	14,9	4250
593B25	3	8	2,5	17,8	4250
593B4	3	8	4	24,3	4250



MODELLO MODEL	RAMI LEGS nr	CATENA CHAIN Ø	LUNGHEZZA LENGTH m	TARA TARE kg	PORTATA LOAD CAPACITY kg
594B2	4	8	2	19,2	4250
594B3	4	8	3	25	4250
594B4	4	8	4	32	4250



/// IMBRAGHI A CATENA PER CESTONI SOLLEVABILI SENZA GANCI ACCORCIATORI
HARNESS CHAINS FOR LIFTING MAN BASKET WITHOUT SHORTENING HOOKS

MODELLO MODEL	RAMI LEGS nr	CATENA CHAIN Ø	LUNGHEZZA LENGTH m	PORTATA LOAD CAPACITY kg
594D3	4	10	3	6700
594D4	4	10	4	6700
594G3	4	13	3	11200
594G4	4	13	4	11200



/// IMBRAGHI A CATENA PER BENNE ELICOTTERO SENZA GANCI ACCORCIATORI
HARNESS CHAINS FOR HELICOPTER BUCKET WITHOUT SHORTENING HOOKS

MODELLO MODEL	RAMI LEGS nr	CATENA CHAIN Ø	LUNGHEZZA LENGTH m	PORTATA LOAD CAPACITY kg
593A08	3	6	0,8	3000



• GRADO 100
GRADE 100

⚠

Gli imbraghi a catena sono accessori di sollevamento che vengono interposti tra l'organo mobile di carico (gancio) dell'apparecchio di sollevamento e la massa da movimentare allo scopo di consentirne la presa, il sollevamento e lo spostamento nello spazio. Gli imbraghi a catena, tramite l'azione dell'apparecchio di sollevamento (gru o paranco) su cui sono installate, possono sollevare la massa da movimentare verticalmente e liberamente nello spazio (senza guide). Gli imbraghi a catena sono progettati e prodotti in considerazione ed in modo da soddisfare tutte le esigenze imposte dai "Requisiti Essenziali di Sicurezza" della Direttiva Comunitaria 2006/42/CE, denominata Direttiva Macchine.

Il D.Lgs n.17 del 27 gennaio 2010 integra la direttiva 2006/42/CE ed indica che gli accessori di sollevamento, le catene, le funi e le cinghie, sono dispositivi amovibili di trasmissione meccanica e quindi rientrano nel "Campo di applicabilità" della Direttiva medesima.

Le funi e le catene debbono inoltre essere sottoposte a controlli trimestrali, anche in mancanza di specifica indicazione da parte del fabbricante, ai sensi del D.Lgs. 81/08, all. 6, punto 3.1.2. Informazioni, marcature e controlli sono quindi prescrizioni di legge imprescindibili anche per gli accessori sottogancio.

The harness chains are lifting accessories that are interposed between the mobile load device (hook) of the lifting appliance and the mass to be moved in order to allow it to be gripped, lifted and moved in space. The chain slings, through the action of the lifting device (crane or hoist) on which they are installed, can lift the mass to be moved vertically and freely in space (without guides).

The chain harnesses are designed and produced in consideration and in order to meet all the requirements imposed by the "Essential Safety Requirements" of the Community Directive 2006/42/EC, called Machinery Directive.

Legislative Decree no. 17 of 27 January 2010 of integrates Directive 2006/42 / EC and indicates that lifting accessories, chains, ropes and straps are removable mechanical transmission devices and therefore are part of the "Field of applicability" of the Directive. The ropes and chains must also be subjected to quarterly checks, even in the absence of specific indication by the manufacturer, pursuant to Legislative Decree 81/08, Annex. 6, point 3.1.2. Therefore, information, markings and controls are mandatory prescriptions for under-hook accessories.

BRACHE IN POLIESTERE
POLYESTER FLAT WEBBING SLINGS



• COEFFICIENTE DI SICUREZZA 7:1
SAFETY FACTOR 7:1

MODELLO MODEL	LUNGHEZZA LENGTH m	H NASTRO RIBBON mm	PORTATA LOAD CAPACITY kg
597A1	1	50	1000
597A2	2	50	1000
597A3	3	50	1000
597A4	4	50	1000
597A5	5	50	1000
597A6	6	50	1000
597A7	7	50	1000
597A8	8	50	1000

MODELLO MODEL	LUNGHEZZA LENGTH m	H NASTRO RIBBON mm	PORTATA LOAD CAPACITY kg
597B1	1	60	2000
597B2	2	60	2000
597B3	3	60	2000
597B4	4	60	2000
597B5	5	60	2000
597B6	6	60	2000
597B7	7	60	2000
597B8	8	60	2000

MODELLO MODEL	LUNGHEZZA LENGTH m	H NASTRO RIBBON mm	PORTATA LOAD CAPACITY kg
597C1	1	90	3000
597C2	2	90	3000
597C3	3	90	3000
597C4	4	90	3000
597C5	5	90	3000
597C6	6	90	3000
597C7	7	90	3000
597C8	8	90	3000

MODELLO MODEL	LUNGHEZZA LENGTH m	H NASTRO RIBBON mm	PORTATA LOAD CAPACITY kg
597D1	1	120	4000
597D2	2	120	4000
597D3	3	120	4000
597D4	4	120	4000
597D5	5	120	4000
597D6	6	120	4000
597D7	7	120	4000
597D8	8	120	4000



CONSIGLI PER L'UTILIZZO IN SICUREZZA
SAFETY ADVICE



Controllare il peso del carico
Check the weight of the load

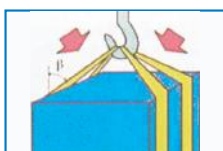

Tener conto del modo di imbragaggio
e dell'angolo di inclinazione
Consider the type of use and the
rake angle

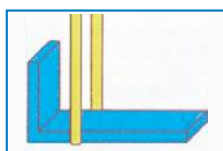

Tenere in considerazione il centro
di gravità del carico
Consider the gravity of inclination
center of the load

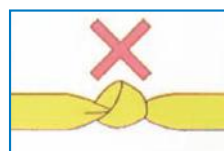

Non torcere o annodare
Don't twist or knot

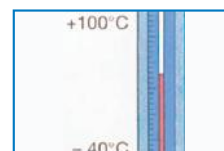

Utilizzare a temperature
comprese tra -40°C e +100°C
Temperature range of use
-40°C to +100°C

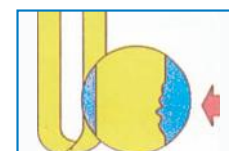

Controllare l'integrità delle fasce
prima di ogni utilizzo
Before any use check that the
slings are not damaged

LIMITAZIONI DELLA PORTATA DI UNA SINGOLA FASCIA DOVUTE A DIVERSI TIPI DI IMPIEGHI
WORKING LOAD LIMIT WITH 1 WEBBING SLING

Portata nominale
Working load limit
(es. 1000 kg)

+ 100% della portata nominale
+ 100% of the working load limit
(es. 1000+1000= 2000 kg)

+ 40% della portata nominale
+ 40% of the working load limit
(es. 1000+400= 1400 kg)

- 20% della portata nominale
- 20% of the working load limit
(es. 1000-200= 800 kg)

CRICCHETTO CON GANCIO TONDINO PER CINGHIA PROFESSIONALE
RATCHET WITH ROD HOOK FOR PROFESSIONAL STRAPS

MODELLO MODEL	LUNGHEZZA LENGTH m	H NASTRO RIBBON H mm	PORTATA LOAD CAPACITY kg
599A6L35	6	35	1000



LIMITAZIONI DELLA PORTATA DI UN SINGOLO CRICCHETTO DOVUTE A DIVERSI TIPI DI IMPIEGHI
WORKING LOAD LIMIT WITH 1 RATCHET STRAP

Portata nominale
Working load limit
(es. 1000 kg)

+ 100% della portata nominale
+ 100% of the working load limit
(es. 1000+1000= 2000 kg)

CRICCHETTO CON GANCIO TONDINO PER CINGHIA PROFESSIONALE
RATCHET WITH ROD HOOK FOR PROFESSIONAL STRAPS

MODELLO MODEL	LUNGHEZZA LENGTH m	H NASTRO RIBBON H mm	PORTATA LOAD CAPACITY kg
599B9L50	9	50	2500



CRICCHETTO ERGONOMICO LEVA LUNGA CON GANCIO TONDINO PER CINGHIA PROFESSIONALE
ERGONOMIC RATCHET WITH LONG LEVER AND ROD HOOK

MODELLO MODEL	LUNGHEZZA LENGTH m	H NASTRO RIBBON H mm	PORTATA LOAD CAPACITY kg
599R9L50E	9	50	2500



I cestoni sollevabili con gru sono progettati e prodotti in considerazione ed in modo da soddisfare tutte le esigenze imposte dai "Requisiti Essenziali di Sicurezza". Sono conformi ai requisiti imposti da:

- NORMA UNI EN 14502-1:2010: APPARECCHI DI SOLLEVAMENTO - ATTREZZATURE PER IL SOLLEVAMENTO DI PERSONE
- D.Lgs 09/04/2008 NR. 81, allegato VI punto 3.1.4
- Il D.Lgs. n. 81/2008 proibisce, come regola generale, l'uso di una macchina per una funzione per la quale non è stata progettata. Tale uso è, però, ammesso "a titolo eccezionale" nei casi previsti a condizione che vengano prese adeguate misure di sicurezza conformemente a disposizioni di buona tecnica.
- Al riguardo, il Ministero del Lavoro e delle Politiche Sociali, considerato che la disposizione in esame è stata introdotta per garantire in concreto valide condizioni di sicurezza ai lavoratori nelle operazioni di sollevamento svolte con attrezzature non previste a tal fine, ritiene che la stessa possa trovare applicazione nei seguenti casi:
- quando si tratti di operare in situazioni di emergenza;
- per attività la cui esecuzione immediata è necessaria per prevenire situazioni di pericolo, incidenti imminenti o per organizzare misure di salvataggio;
- quando per l'effettuazione di determinate operazioni rese necessarie dalla specificità del sito o del contesto lavorativo le attrezzature disponibili o ragionevolmente reperibili sul mercato non garantiscono maggiori condizioni di sicurezza.
- Le seguenti operazioni di sollevamento persone con attrezzature non specificamente previste, unicamente nei casi indicati, vanno effettuate secondo specifiche procedure di sicurezza che comprendano a valle una analisi dei rischi, i criteri per la scelta più appropriata delle attrezzature da impiegare, i requisiti delle apparecchiature accessorie da abbinare ad essi, le modalità operative per le varie fasi di lavoro in cui i sistemi così realizzati sono utilizzati nonché quelle per la sorveglianza ed il controllo delle une e delle altre.



The lifting man basket are designed and produced taking satisfying all the requirements imposed by the "Essential Safety Requirements".

- Complies with the requirements imposed from:
- STANDARD UNI EN 14502-1:2010: LIFTING EQUIPMENT - EQUIPMENT FOR LIFTING PEOPLE
 - Leg. Dec. 09/04/2008 NR. 81, attachment VI, point 3.1.4
 - Legislative Decree no. 81/2008 prohibits, as a general rule, the use of a machine for a function for which it has not been designed. Such use is, however, admitted "in exceptional cases" provided that appropriate security measures are taken in accordance with good technical provisions.
 - In this regard, the Ministry of Labor and Social Policies, given that this provision was introduced in order to guarantee valid safety conditions for workers in lifting operations carried out with equipment not provided for this purpose, the Ministry of Labor and Social Policies believes that it can be applied in the following cases:
 - when dealing with emergency situations;
 - for activities whose immediate execution is necessary to prevent dangerous situations, imminent incidents or to arrange rescue measures;
 - whenever the performance of any operations required by the specifics of the site or of the workplace context, the equipment available or reasonably available on the market does not guarantee greater security conditions. Lifting people with equipment not specifically provided, only in the cases indicated, should be carried out in accordance with specific safety procedures which include a risk analysis, criteria for the most appropriate choice of equipment to be used, requirements for ancillary equipment to combine with, the operating modes for the various work phases in which the systems thus realized are used as well as those for the surveillance and control of one another and of the others.

/// CESTONE SOLLEVABILE PER 1 PERSONA, ZINCATO
LIFTING MAN BASKET FOR 1 PERSON, ZINC COATED

MODELLO MODEL	DIMENSIONI DIMENSIONS mm			N° PERSONE A BORDO No. OF PEOPLE ON BOARD	TARA TARE kg	PESO PIENO CARICO TOTAL FULL LOAD WEIGHT kg	PORTATA LOAD CAPACITY kg
	H1	H2	Ø				
367AR	2400	1150	660	1	80	230	150

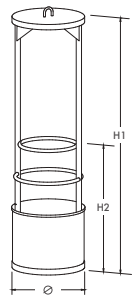

/// CESTONE SOLLEVABILE PER 2 PERSONE, ZINCATO
LIFTING MAN BASKET FOR 2 PEOPLE, ZINC COATED

MODELLO MODEL	DIMENSIONI DIMENSIONS mm			N° PERSONE A BORDO No. OF PEOPLE ON BOARD	TARA TARE kg	PESO PIENO CARICO TOTAL FULL LOAD WEIGHT kg	PORTATA LOAD CAPACITY kg
	H1	H2	Ø				
367BR	2400	1150	950	2	138	438	300

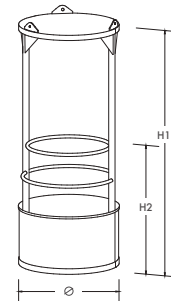

/// CESTONE SOLLEVABILE PER 4 PERSONE
LIFTING MAN BASKET FOR 4 PEOPLE

MODELLO MODEL	DIMENSIONI DIMENSIONS mm				N° PERSONE A BORDO No. OF PEOPLE ON BOARD	TARA TARE kg	PESO PIENO CARICO TOTAL FULL LOAD WEIGHT kg	PORTATA LOAD CAPACITY kg
	L	P	H1	H2				
367	1400	1000	2400	1280	4	312	812	500

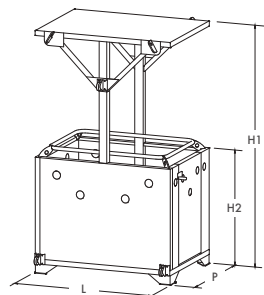

/// ACCESSORI | ACCESSORIES

99C201
KIT
IMBRAGATURA
DA LAVORO
HARNES KIT

99C376
CASCHETTO
DI SICUREZZA
SECURITY
HELMET

SOTTO GANCIO
PER 367AR
ONE LEG SLING
FOR 367AR

MODELLO MODEL	CATENA CHAIN Ø	LUNGHEZZA LENGHT m	PORTATA LOAD CAPACITY kg
591D1	10	1	3150
591F1	13	1	5300

CATENA 3 RAMI
PER 367BR
3 LEGS CHAIN
FOR 367BR

MODELLO MODEL	CATENA CHAIN Ø	LUNGHEZZA LENGHT m	PORTATA LOAD CAPACITY kg
593B25	8	2,5	4250
593B4	8	4	4250

CESTONE SOLLEVABILE CON TETTO SFILABILE PER 4 PERSONE
LIFTING MAN BASKET WITH REMOVABLE ROOF FOR 4 PEOPLE

MODELLO MODEL	DIMENSIONI DIMENSIONS mm				N° PERSONE A BORDO No. OF PEOPLE ON BOARD	TARA TARE kg	PESO PIENO CARICO TOTAL FULL LOAD WEIGHT kg	PORTATA LOAD CAPACITY kg
	L	P	H1	H2				
367TS	1400	1000	2400	1280	4	345	845	500

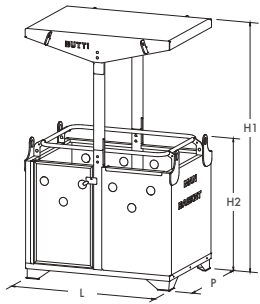

CESTONE SOLLEVABILE STANDARD PER 5 PERSONE
CESTONE SOLLEVABILE STANDARD PER 5 PERSONE LIFTING MAN BASKET FOR 5 PEOPLE

MODELLO MODEL	DIMENSIONI DIMENSIONS mm				N° PERSONE A BORDO No. OF PEOPLE ON BOARD	TARA TARE kg	PESO PIENO CARICO TOTAL FULL LOAD WEIGHT kg	PORTATA LOAD CAPACITY kg
	L	P	H1	H2				
367L	2500	1400	2400	1280	5	555	1155	600

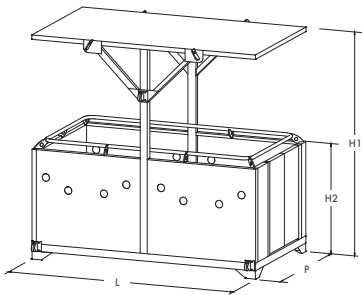

CESTONE SOLLEVABILE PER PRONTO INTERVENTO
FIRST AID LIFTING MAN BASKET



MODELLO MODEL	DIMENSIONI DIMENSIONS mm				N° PERSONE A BORDO No. OF PEOPLE ON BOARD	TARA TARE kg	PESO PIENO CARICO TOTAL FULL LOAD WEIGHT kg	PORTATA LOAD CAPACITY kg
	L	P	H1	H2				
367F	2500	1400	2400	1280	4+1	555	1155	600

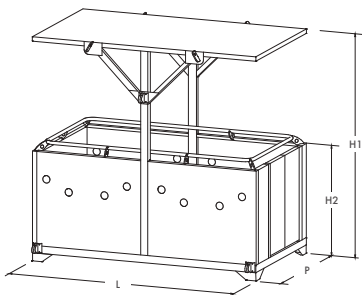

ACCESSORI | ACCESSORIES //



CESTONA 4 RAMI
PER 367, 367TS
4 LEGS CHAIN
FOR 367, 367TS



MODELLO MODEL	CATENA CHAIN Ø	LUNGHEZZA LENGTH m	PORTATA LOAD CAPACITY kg
594D3	10	3	6700
594D4	10	4	6700



CESTONA 4 RAMI
PER 367L, 367F
4 LEGS CHAIN
FOR 367L, 367F



MODELLO MODEL	CATENA CHAIN Ø	LUNGHEZZA LENGTH m	PORTATA LOAD CAPACITY kg
594G3	13	3	11200
594G4	13	4	11200



99C334
BARELLA TOBOGA CON
CINTURE E POGGIAPIEDI
PER 367F
TOBOGA STRETCHER WITH
SAFETY BELT AND FOOTREST
FOR 367F

CONTENITORE PER MANUTENZIONE AEREA PER 1 PERSONA
BASKET FOR AERIAL MAINTENANCE FOR 1 PERSON

MODELLO MODEL	DIMENSIONI DIMENSIONS mm				PORTATA LOAD CAPACITY kg
	L	P	H	H1	
975	1000	1000	2000	1200	400



QUOTE SEDI FORCHE INTERNE | INTERNAL FORK SEATS DIMENSIONS

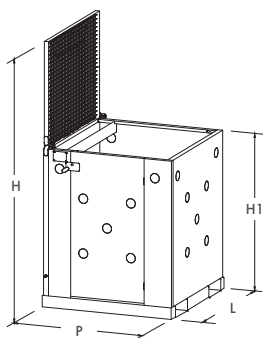
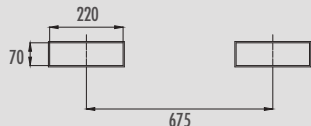

CONTENITORE PER MANUTENZIONE AEREA PER 2 PERSONE
BASKET FOR AERIAL MAINTENANCE FOR 2 PEOPLE

MODELLO MODEL	DIMENSIONI DIMENSIONS mm				PORTATA LOAD CAPACITY kg
	L	P	H	H1	
975P2	1500	1000	2000	1200	400



QUOTE SEDI FORCHE INTERNE | INTERNAL FORK SEATS DIMENSIONS

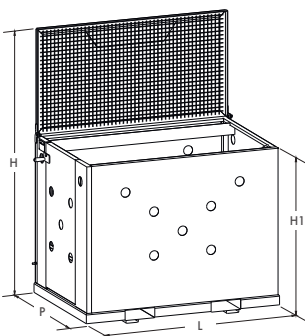
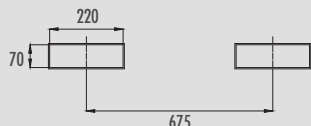

La sicurezza del lavoratore nelle operazioni di sollevamento in quota è assicurata grazie ai contenitori per manutenzione aerea. Conformi a tutte le normative vigenti, assicurano la stabilità necessaria a lasciare libero il lavoratore nei movimenti ed eliminando i rischi di caduta. Il contenitore per manutenzione aerea è corredato di manuale d'uso e relative istruzioni di utilizzo in osservanza a quanto richiesto dal D.Lgs. 9 aprile 2008 n. 81, punto 3.1.4 allegato VI.

Worker's safety during lifting operations is guaranteed by using the baskets for aerial maintenance. They comply with all current regulations and ensure the necessary balance the worker needs to be free to move without any risk of fall. The basket for aerial maintenance is accompanied by user manual and related instructions for use in compliance with the provisions of Legislative Decree 9 April 2008, no. 81, point 3.1.4 annex VI.



ACCESSORI | ACCESSORIES

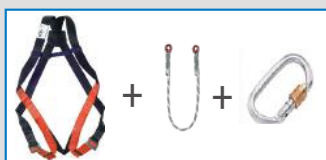

99C201
KIT IMBRAGATURA DA LAVORO:
IMBRAGATURA PER IL CORPO + CORDINO DI TRATTENIMENTO
+ MOSCHETTONE
HARNESS KIT:
BODY HARNESS + RETENTION ROPE + CARABINER



99C376
CASCHETTO DI SICUREZZA
SECURITY HELMET



99C376
RUOTE CON FRENO Ø
125 mm GIREVOLI
SWIVEL WHEELS Ø 125
mm WITH BRAKE



YOUTUBE VIDEO

////// SCOPIA INDUSTRIALE UNIVERSAL
INDUSTRIAL BROOM UNIVERSAL

MODELLO MODEL	DIMENSIONI DIMENSIONS mm			N° DI FILI No. OF WIRES	FILE ROW	TARA TARE kg	SPAZZOLE BRUSHES
	L	P	H				
863UC20 Compact	2000	500	370	16800	3	161	Acciaio alta qualità High quality steel
865UC20 Classic	2000	800	380	28000	5	268	Acciaio alta qualità High quality steel
865UC25 Large	2500	800	380	35000	5	318	Acciaio alta qualità High quality steel



////// QUOTE SEDI FORCHE INTERNE | INTERNAL FORK SEATS DIMENSIONS

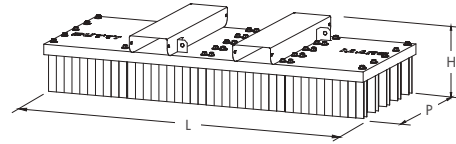
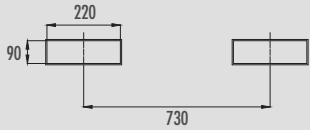

////// SCOPIA MAGNETICA MANUALE "EASY"
HAND HELD MAGNETIC BROOM "EASY"

MODELLO MODEL	DIMENSIONI DIMENSIONS mm					TARA TARE kg
	L1	L2	P1	P2	H	
867M0210SM	1220	1070	850	250	1050	60

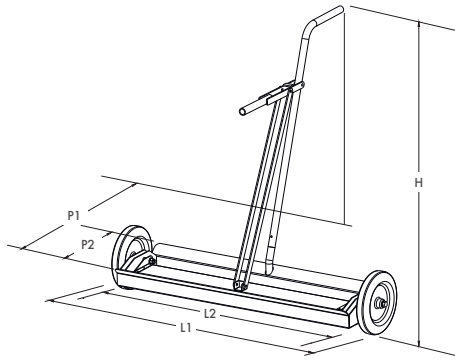

YOUTUBE VIDEO

////// SCOPIA MAGNETICA
MAGNETIC BROOMS

MODELLO MODEL	DIMENSIONI DIMENSIONS mm		
	L	P	H
867M0515	1500	600	280
867M0525	2500	600	300
867M0530	3000	600	300



////// QUOTE SEDI FORCHE INTERNE | INTERNAL FORK SEATS DIMENSIONS

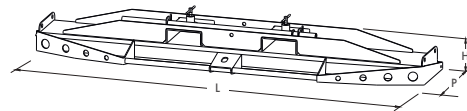

////// QUOTE SEDI FORCHE INTERNE | INTERNAL FORK SEATS DIMENSIONS

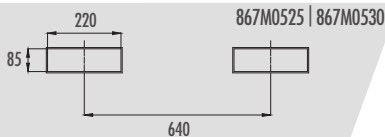

• Sistema di apertura facilitato
Easy opening system

ACCESSORI | ACCESSORIES //



//////
KIT DI RICAMBIO SPAZZOLE IN ACCIAIO DI ALTA QUALITÀ
HIGH QUALITY STEEL BRUSH REPLACEMENT KIT

VASCA DI LAVAGGIO
WASHING TANK

MODELLO MODEL	DIMENSIONI DIMENSIONS mm			VOLUME lit
	L	P	H	
900	700	560	810	60

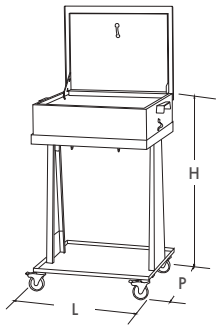

VASCA DI LAVAGGIO
WASHING TANK

MODELLO MODEL	DIMENSIONI DIMENSIONS mm			VOLUME lit
	L	P	H	
901	1000	560	810	90

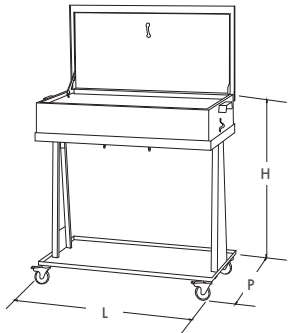

CARRELLO LAVAPEZZI
PARTS WASHING CART

MODELLO MODEL	DIMENSIONI DIMENSIONS mm			VOLUME lit
	L	P	H	
935	1150	705	900	65

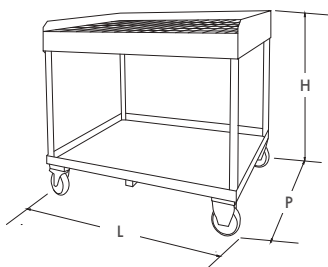

ROLL CONTAINER CON RUOTE
ANTI-THEFT ROLL CONTAINER WITH WHEELS

MODELLO MODEL	DIMENSIONI DIMENSIONS mm			PORTATA LOAD CAPACITY kg
	L	P	H	
881B05RGV	1200	800	1800	400



- 4 ruote, 2 fisse e 2 girevoli con freno
4 wheels, 2 fixed and 2 swivel with brake
- Ripiano non incluso, disponibile su richiesta
Shelf not included, available on request

CONTENITORE PER BATTERIE ESAUSTE
CONTAINER FOR EXHAUSTED BATTERIES

MODELLO MODEL	DIMENSIONI DIMENSIONS mm			VOLUME lt
	L	P	H	
98CNT250P	920	710	840	250



- Vasca dotata di coperchio incernierato asportabile in polietilene
Tank equipped with removable hinged lid in polyethylene
- Corpo vasca alloggiato all'interno di una struttura metallica aperta verniciata antiacido
Tank body housed inside an open metal structure painted antiacid
- Portaforche antiribaltamento per muletti o transpallet
Anti-tip fork holder for forklift or transpallet
- Movimentazione e impilabilità sino a tre unità
Handling and stacking up to three units
- Conforme D.P.R. 915 - 10/09/1982
In compliance with D.P.R. 915 - 10/09/1982
- Caratteristiche tecniche approvate dal consiglio di amministrazione COBAT
Technical characteristics approved by the COBAT board of directors

KIT PRONTO INTERVENTO PER LIQUIDI UNIVERSALI
FIRST REACTION KIT FOR ALL FLUIDS

MODELLO MODEL	DIMENSIONI DIMENSIONS mm			CONTENUTO CONTENTS	ASSORBIMENTO ABSORPTION lt	VOLUME lt
	L	P	H			
909KL120	480	550	950	50 panni rags 41x46cm 6 cuscini cushions 46x46cm 12 calze filters Ø 7,6x122cm 1 Kit Protect (whitesorb non incluso/not included)	124	120
909KL240	580	750	1100	150 panni rags 41x46cm 8 cuscini cushions 46x46cm 12 calze filters Ø 7,6x122cm 1 Kit Protect (whitesorb non incluso/not included)	265	240
909KL360	580	900	1100	200 panni rags 41x46cm 12 cuscini cushions 46x46cm 12 calze filters Ø 7,6x122cm 6kg WHITESORB-C 1 Kit Protect	348	360



• Può contenere liquidi universali come acqua, idrocarburi, liquidi organici e inorganici chimici, solventi antigelo
It can contain universal liquids like water, hydrocarbon, chemical, organic and inorganic liquids, antifreezing solvents

KIT PRONTO INTERVENTO PER PRODOTTI CHIMICI
FIRST REACTION KIT FOR CHEMICAL PRODUCTS

MODELLO MODEL	DIMENSIONI DIMENSIONS mm			CONTENUTO CONTENTS	ASSORBIMENTO ABSORPTION lt	VOLUME lt
	L	P	H			
909KP120	480	550	950	50 panni rags 41x46cm 6 cuscini cushions 46x46cm 12 calze filters Ø 7,6x122cm 1 Kit Protect (acidsorb non incluso/not included)	124	120
909KP240	580	750	1100	150 panni rags 41x46cm 8 cuscini cushions 46x46cm 12 calze filters Ø 7,6x122cm 1 Kit Protect (acidsorb non incluso/not included)	265	240
909KP360	580	900	1100	200 panni rags 41x46cm 12 cuscini cushions 46x46cm 12 calze filters Ø 7,6x122cm 6kg ACIDSORB-C 1 Kit Protect	348	360



• Può contenere prodotti chimici
It can contain chemical products

BIDONE CARRELLATO CON COPERCHIO PER LA RACCOLTA DIFFERENZIATA
WHEELED BINS RECYCLING BIN WITH LID

MODELLO MODEL	DIMENSIONI DIMENSIONS mm			PESO WEIGHT kg	CAPACITÀ DI CARICO LOAD CAPACITY kg	VOLUME lt	COLORI DISPONIBILI AVAILABLE COLOURS
	L	P	H				
941L120-	480	550	930	9	60	120	
941L240-	580	730	1070	13	116	240	Giallo, blu, verde, rosso, marrone, grigio, bianco <i>Yellow, blue, green, red, brown, grey, white</i>

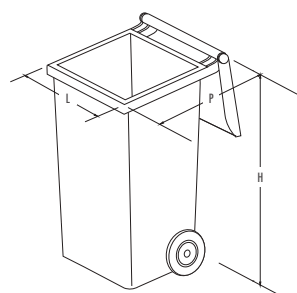

• Ideali per la suddivisione dei rifiuti nelle industrie
Ideal for the subdivision of waste in the industries
• Dotati di una pratica maniglia per facilitarne la movimentazione
Equipped with a practical handle for easy moving
• Realizzati in polietilene ad alta densità
Made of high-density polyethylene
• Con 2 ruote di diametro 200 mm
With 2 wheels of 200 mm diameter

ASSORBENTE GRANULARE PER PRODOTTI LIQUIDI E OLEOSI
GRANULAR ABSORBENT FOR LIQUID AND OILY PRODUCTS

MODELLO MODEL	CARATTERISTICHE FEATURES
909G0512	Granulare fine 12 Kg (secchio) <i>Fine granular 12 Kg (bucket)</i>



COMPOSTO GRANULARE ASSORBENTE E NEUTRALIZZANTE PER ACIDI
GRANULAR ABSORBENT AND NEUTRALIZER FOR ACIDS

MODELLO MODEL	CARATTERISTICHE FEATURES
909P0805	Granulare 6 Kg (secchio) <i>Granular 6 Kg (bucket)</i>





YOUTUBE VIDEO

////// SPAZZANEVE FISSO CON RASCHIANTE IN ACCIAIO NON INTERCAMBIABILE
FIXED SNOWPLOW WITH STEEL SCRAPER NOT INTERCHANGEABLE

MODELLO MODEL	DIMENSIONI DIMENSIONS mm			AMMORTIZZATORI SHOCK ABSORBERS	POSIZIONE RASCHIANTE SCRAPER POSITION	RASCHIANTE SCRAPER
	L	P	H			
87814	1415	1330	700	1	20° verso destra 20° on the right	Acciaio Steel

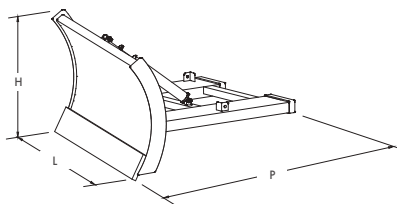

////// QUOTE SEDI FORCHE INTERNE | INTERNAL FORK SEATS DIMENSIONS

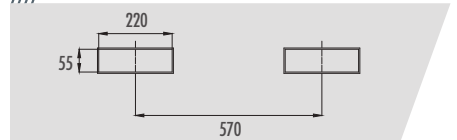

////// SPAZZANEVE ORIENTABILE CON RASCHIANTE IN POLIURETANO INTERCAMBIABILE
ADJUSTABLE SNOWPLOW WITH INTERCHANGEABLE POLYURETHANE SCRAPER

MODELLO MODEL	DIMENSIONI DIMENSIONS mm			AMMORTIZZATORI SHOCK ABSORBERS	POSIZIONE RASCHIANTE SCRAPER POSITION	RASCHIANTE SCRAPER
	L	P	H			
87815ORG	1515	1360	740	1	0°-15°-30° verso destra o sinistra on the right or left	Poliuretano Polyurethane
87823ORG	2265	1800	740	2	0°-15°-30° verso destra o sinistra on the right or left	Poliuretano Polyurethane



////// QUOTE SEDI FORCHE INTERNE | INTERNAL FORK SEATS DIMENSIONS



////// QUOTE SEDI FORCHE INTERNE | INTERNAL FORK SEATS DIMENSIONS

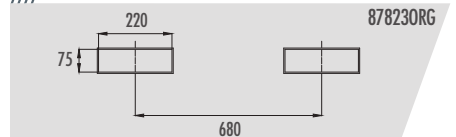

////// SPARGISALE PROFESSIONALE A MANO
PROFESSIONAL MANUAL SALT SPREADER

MODELLO MODEL	VELOCITÀ DI LAVORO WORKING SPEED km/h	PORTATA LOAD CAPACITY kg
876K25	1/4	25
876K50	1/4	50



////// CARRELLO SPARGISALE PROFESSIONALE A TRAINO
PROFESSIONAL TOWING SALT SPREADER

MODELLO MODEL	VELOCITÀ DI LAVORO WORKING SPEED km/h	PORTATA LOAD CAPACITY kg
877K150	10/15	150



YOUTUBE VIDEO

////// PANTHER FRESANEVE
PANTHER SNOW BLOWER

MODELLO MODEL	DIMENSIONI DIMENSIONS mm			MOTORE ENGINE	VELOCITÀ MOTORE ENGINE SPEED min	POTENZA MOTORE ENGINE POWER cv hp
	L	P	H			
879PFD2 Panther	800	700	1240	Motore a scoppio monocilindrico raffreddato ad aria Briggs & Stratton Briggs & Stratton air cooled single cylinder engine	3000	6,5



MODELLO MODEL	DIMENSIONI DIMENSIONS mm			RAGGIO DI AZIONE ACTION RANGE mm
	L	P	H	
879SF70 Turbo fresa Snow blower	740	750	880	700



TRANSPALLET BIRULLO
DUAL ROLLER TRANSPALLET

MODELLO MODEL	DIMENSIONI DIMENSIONS mm				PORTATA LOAD CAPACITY kg
	L	P	H max	H min	
700	1150	525	200	85	2500
700PX25 pesatore scale	1185	555	115	90	2500

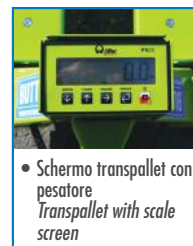
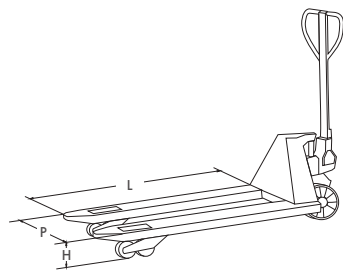

- Schermo transpallet con pesatore
Transpallet with scale screen

TAGLIAFUSTI PER LA RIMOZIONE COPERCHI DEI FUSTI METALLICI
DRUMS DEHEADER FOR THE REMOVAL OF METAL DRUM COVERS

MODELLO MODEL
925



CHIAVE PER FUSTI
KEY FOR DRUMS

MODELLO MODEL
99C394



BASE CIRCOLARE A TENUTA STAGNA PER MOVIMENTAZIONE FUSTI
DRUM DOLLY WITH WATERTIGHT TRAY

MODELLO MODEL	DIMENSIONI DIMENSIONS mm		PORTATA LOAD CAPACITY kg
	Ø	H min	
927AT	600	270	350



BASE CIRCOLARE NON A TENUTA STAGNA PER MOVIMENTAZIONE FUSTI
NON WATERTIGHT DRUM DOLLY

MODELLO MODEL	DIMENSIONI DIMENSIONS mm		PORTATA LOAD CAPACITY kg
	Ø	H min	
927AT300	680	300	300



TAPPETO ANTI TRAUMA IN GOMMA
ANTI-SHOCK RUBBER MAT

MODELLO MODEL	DIMENSIONI DIMENSIONS mm			DUREZZA HARDNESS shore
	L	P	SPESORE THICKNESS	
953TM10F	1000	1000	15	28/34



- Spessore
Thickness

////// ELEKTRO-12 POMPA PROFESSIONALE CON BATTERIA AL LITIO IDEALE PER LA SANIFICAZIONE
ELEKTRO-12 LITHIUM BATTERY POWERED PROFESSIONAL SPRAYER FOR SANITIZING

MODELLO MODEL	PORTATA LOAD CAPACITY kg
619EL12	12

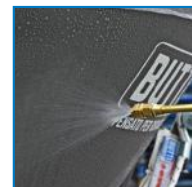

• PISTOLA CON ATTACCO GIREVOLE E GRUPPO FINALE IN OTTONE PROFESSIONALI
PROFESSIONAL BRASS DISCHARGE VALVE WITH SWIVEL ATTACHMENT AND COMPLETE SPRAYLANCE

////// POMPA PROFESSIONALE IN ACCIAIO INOX IDEALE PER LA SANIFICAZIONE
PROFESSIONAL STAINLESS STEEL SPRAYER IDEAL FOR SANITIZING

MODELLO MODEL	PORTATA LOAD CAPACITY kg
619IX	10

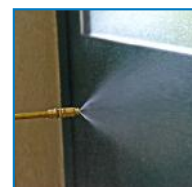

• PISTOLA CON ATTACCO GIREVOLE E GRUPPO FINALE IN OTTONE PROFESSIONALI
PROFESSIONAL BRASS DISCHARGE VALVE WITH SWIVEL ATTACHMENT AND COMPLETE SPRAYLANCE

////// BENNA SABBIA CON RIBALTAMENTO AUTOMATICO
SAND BUCKET WITH AUTOMATIC ROLL OVER

MODELLO MODEL	DIMENSIONI DIMENSIONS mm				TARA TARE kg	PESO PIENO CARICO TOTAL FULL LOAD WEIGHT kg	PORTATA LOAD CAPACITY kg	VOLUME litri
	L	P1	P2	H				
310	1200	1450	950	700	170	1070	900	500

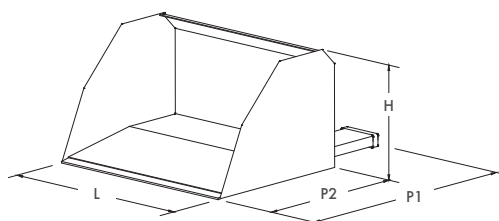

• A richiesta:
SISTEMA DI RIBALTAMENTO IDRAULICO
On demand:
HYDRAULIC TIPPING SYSTEM

////// QUOTE SEDI FORCHE INTERNE | INTERNAL FORK SEATS DIMENSIONS



////// ACCESSORI PER LA SICUREZZA DEL LAVORATORE
ACCESSORIES FOR WORKER SAFETY

MODELLO MODEL	CARATTERISTICHE FEATURES
99C201	KIT IMBRAGATURA DA LAVORO: Imbragatura per il corpo + Cordino di trattenimento + Moschettone HARNESS KIT: Body harness + Retention rope + Carabiner

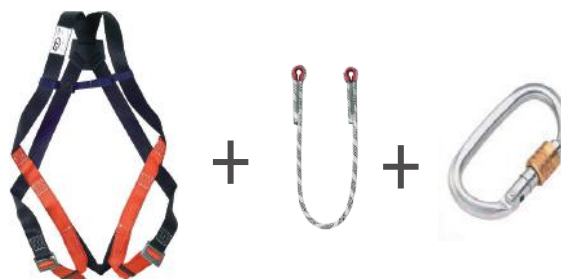

MODELLO MODEL	CARATTERISTICHE FEATURES
99C376	Caschetto alta sicurezza, a richiesta con occhiali High safety security helmet, on request with glasses



• Occhiali a richiesta
Glasses on request

PROLUNGHE PER FORCHE
FORK EXTENSIONS



Prima di montare le prolunghe verificare che le forche del carrello elevatore non presentino rotture e abbiano i piani di appoggio dritti.
Before mounting the extension, verify that the forks of the forklift do not present breakages and have straight support surface.



MONTAGGIO SULLE FORCHE
MOUNTING ON THE FORKS

- Smontare il perno di bloccaggio (1)
Remove the locking pin (1)
- Infilare completamente le forche all'interno delle prolunghe
Insert the forks completely into the extension
- Rimontare il perno di bloccaggio (1)
Refit the locking pin (1)
- Controllare che la prolunga non si possa sganciare
Check that the extension cannot unhook

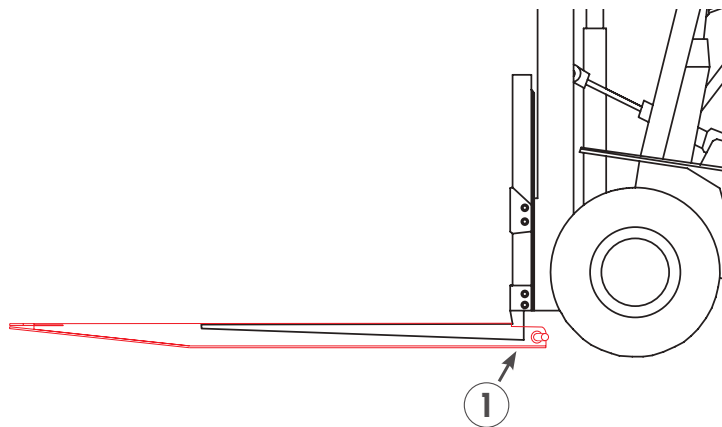

NORME DI UTILIZZO
USAGE RULES

- Osservare i limiti di portata del carrello
Respect the capacity limits of the forklift
- Non installare le prolunghe su forche con lunghezza minore di:
Do not install the extensions on forks shorter than:

$$P = \frac{3 \times D}{2}$$

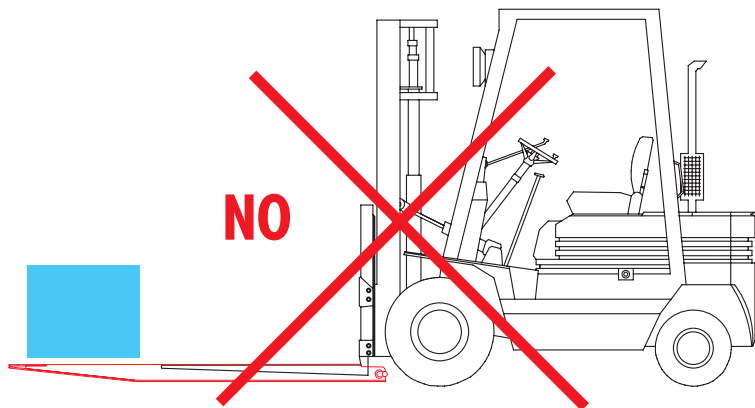
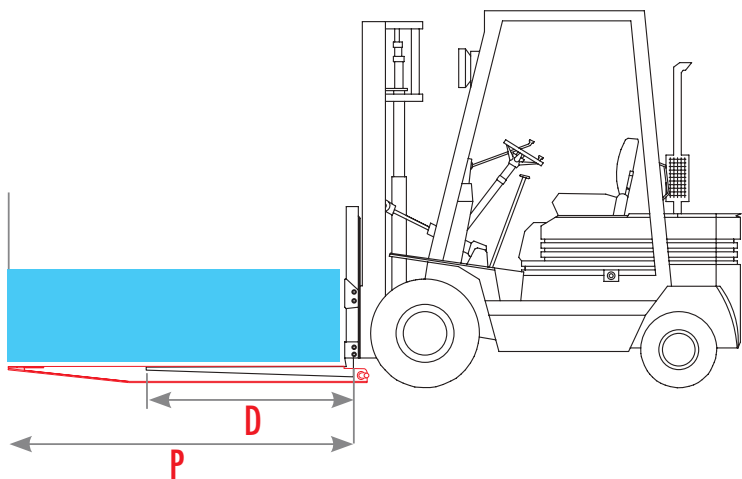

- Non installare le prolunghe su forche con sezione minore di quella prevista
Do not install the extensions on forks with cross section smaller than that required
- Non movimentare carichi con la punta delle prolunghe
Never pick up a load with the tip of the extension
- Non movimentare carichi per spinta con la punta delle prolunghe
Do not handle loads by pushing with the tips of the extensions
- Non sollevare persone
Do not lift people



IL COSTRUTTORE SI RITIENE SOLLEVATO DA EVENTUALI RESPONSABILITÀ IN CASO DI USO IMPROPRIO O INADEGUATO DELLE PROLUNGHE PER FORCHE
THE MANUFACTURER SHALL NOT BE LIABLE IN CASE OF MISUSE OR IMPROPER USE OF THE FORKS EXTENSIONS





SOLUZIONI PER LA LOGISTICA INDUSTRIALE
SOLUTIONS FOR INDUSTRIAL LOGISTICS



PENSATO PER DURARE

BUTTI srl - Via Mayer, 13 | 24034 Cisano Bergamasco (BG) | Tel. +39 035 787300 | butti@butti.it | butti.it