

# CD103M Dri-Prime® Pump

WITH FINAL TIER 4 (FT4) DIESEL ENGINE

The Godwin Dri-Prime CD103M pump offers flow rates to 1020 USGPM and has the capability of handling solids up to 3.0" in diameter.

The CD103M is able to automatically prime to 28' of suction lift from dry. Automatic or manual starting/stopping available through integral mounted control panel or optional wireless-remote access.

Indefinite dry-running is no problem due to the unique Godwin liquid bath mechanical seal design. Solids handling, dry-running, and portability make the CD103M the perfect choice for dewatering and bypass applications.



## Features and Benefits

- Simple maintenance normally limited to checking fluid levels and filters.
- Dri-Prime (continuously operated Venturi air ejector priming device) requiring no periodic adjustment. Optional compressor clutch available.
- Extensive application flexibility handling sewage, slurries, and liquids with solids up to 3.0" in diameter.
- Dry-running high pressure liquid bath mechanical seal with high abrasion resistant solid silicon carbide faces.
- Close-coupled centrifugal pump with Dri-Prime system coupled to a diesel engine or electric motor.
- All cast iron construction (stainless steel construction option available) with cast steel impeller.
- Also available in a critically silenced unit which reduces noise levels to less than 70 dBA at 30'.
- Standard engine Isuzu 4LE2T (FT4) EPA emissions compliant diesel engine. Also available with Kohler KDI1903TCR (FT4).

## Specifications

Suction connection	4" 150# ANSI B16.5
Delivery connection	4" 150# ANSI B16.5
Max capacity	1020 USGPM †
Max solids handling	3.0"
Max impeller diameter	10.1"
Max operating temp	176°F*
Max working pressure	80 psi
Max suction pressure	58 psi
Max casing pressure	120 psi
Max operating speed	2200 rpm

\* Please contact our office for applications in excess of 176°F.

† Larger diameter pipes may be required for maximum flows.

SOLD BY



**AQUOSIS**  
FLUID SOLUTIONS

info@aquosis.com  
1.877.907.7852

Please contact the factory or office for further details. A typical picture of the pump is shown. All information is approximate and for general guidance only.

godwin   
a xylem brand

## Performance Curve

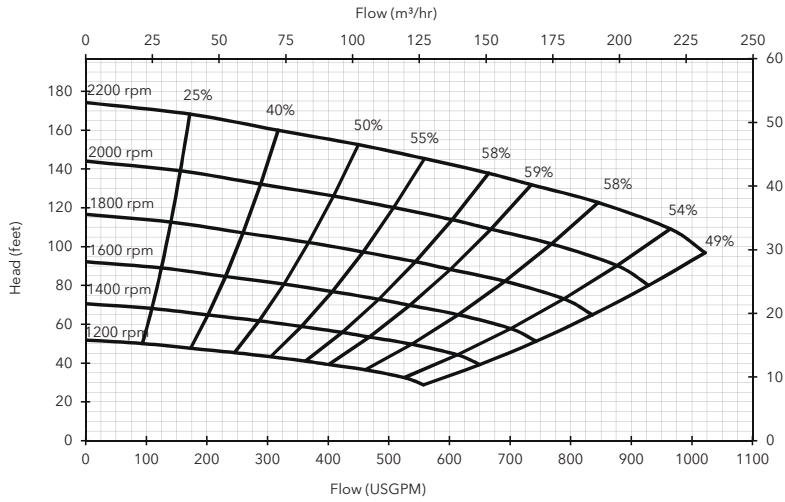

### Engine option 1

Isuzu 4LE2T (FT4), 46 HP @ 2200 rpm

Impeller diameter 10.1"

Pump speed 2200 rpm

#### Suction Lift Table

Total Suction Head (feet)	Total Delivery Head (feet)				
	78	103	127	152	176
	Output (USGPM)				
10	1022	915	646	350	-
15	996	834	538	215	-
20	888	753	431	-	-
25	807	646	269	-	-

Fuel capacity: 60 US Gal

Max fuel consumption @ 2200 rpm: 3.1 US Gal/hr

Max fuel consumption @ 1800 rpm: 1.8 US Gal/hr

Weight (Dry): 2,400 lbs

Weight (Wet): 2,830 lbs

Dim.: (L) 119" x (W) 66" x (H) 77"

Performance data provided in tables is based on water tests at sea level and 20°C ambient. All information is approximate and for general guidance only. Please contact the factory or office for further details.

## Materials

Pump casing & suction cover	Cast iron BS EN 1561 - 1997
Wearplates	Cast iron BS EN 1561 - 1997
Pump Shaft	Carbon steel BS 970 - 1991 817M40T
Impeller	Cast Steel BS3100 A5 Hardness to 200 HB Brinell
Non-return valve body	Cast iron BS EN 1561 - 1997
Mechanical seal	Silicon carbide face; Viton elastomers; Stainless steel body

### Engine option 2

Kohler KDI1903TCR (FT4), 56 HP @ 2200 rpm

Impeller diameter 10.1"

Pump speed 2200 rpm

#### Suction Lift Table

Total Suction Head (feet)	Total Delivery Head (feet)				
	78	103	127	152	176
	Output (USGPM)				
10	1022	915	646	350	-
15	996	834	538	215	-
20	888	753	431	-	-
25	807	646	269	-	-

Fuel capacity: 60 US Gal

Max fuel consumption @ 2200 rpm: 2.8 US Gal/hr

Max fuel consumption @ 1800 rpm: 1.6 US Gal/hr

Weight (Dry): 2,780 lbs

Weight (Wet): 3,210 lbs

Dim.: (L) 119" x (W) 66" x (H) 77"

Performance data provided in tables is based on water tests at sea level and 20°C ambient. All information is approximate and for general guidance only. Please contact the factory or office for further details.

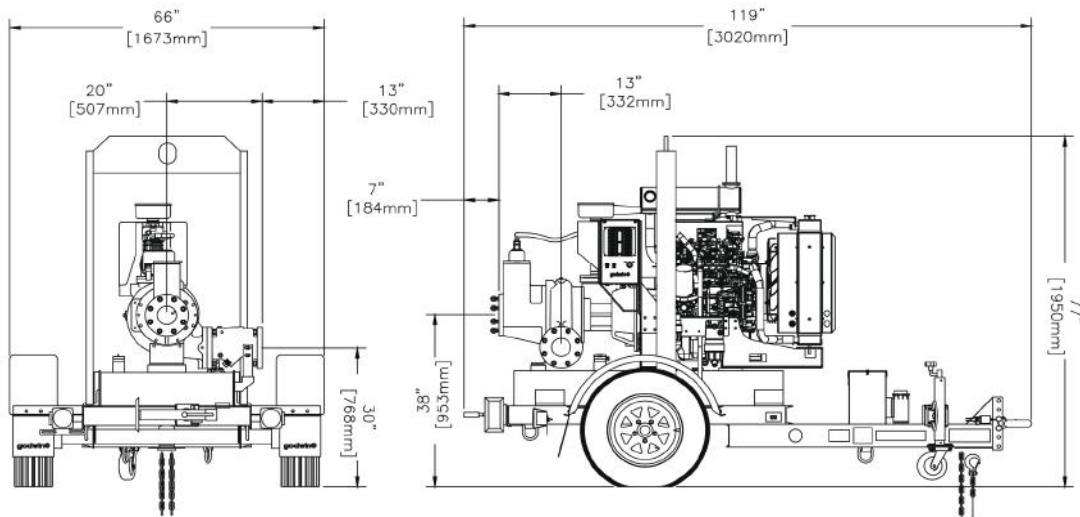

84 Floodgate Road  
Bridgeport, NJ 08014 USA  
(856) 467-3636 · Fax (856) 467-4841

SOLD BY



info@aquosis.com  
1.877.907.7852