

AEG

Premier Partner

Cooking Result
Rare
• Medium
Well Done

CHALLENGE THE
AEG
EXPECTED

Kitchen and Laundry range

AEG.CO.UK

AEG

WE ARE AEG

We lead by challenging convention and creating innovations that go beyond what you expect from appliances in your home.

We create innovations that stand out today and help build a better tomorrow.

With our constant drive to aim higher, our uncompromising approach to innovation and relentless responsibility, we challenge the expected and create responsible innovations that redefine how you use your appliances.

Since our start in Berlin in 1887, we have never settled for good enough. And we don't think you should have to either.



INTRODUCTION

Why buy from an AEG Premier Partner?

Your Warranty

Find your nearest AEG Premier Partner

Our Technology

Matt Black Collection

REFRIGERATION

Integrated Fridge Freezers

Integrated Fridges and Freezers

Freestanding Fridge Freezers

Wine Cooling

OVENS

Connected Cooking

Single Ovens

Built-In Double Oven

Built Under Double Ovens

Compacts

Microwave Ovens

Blackline Range

HOBS

Induction Hobs

Ceramic Hob

Gas Hobs

Mixed Fuel Hob

Modular Hob

Extractor Hobs

HOODS

Island Hoods

Ceiling Hoods

Chimney Hoods

Integrated Hoods

DISHWASHERS

Fully Integrated Dishwashers

Slimline Fully Integrated Dishwasher

LAUNDRY

Built-In Washing Machine

Built-in Washer Dryer

Freestanding Washing Machines

Freestanding Tumble Dryers

Freestanding Washer Dryers

SMALL APPLIANCES & ACCESSORIES

INSTALLATION DIAGRAMS

ENERGY INFORMATION

PREMIER. A MINIMUM STANDARD FOR OUR PARTNERS

When you step into a kitchen studio with approved AEG Premier Partner status, you know you're going to get the exceptional level of performance and service that you come to expect from AEG.

AEG

Premier Partner

TAKE ADVANTAGE OF THESE
BENEFITS WHEN YOU VISIT
ONE OF OUR PARTNER
KITCHEN STUDIOS.

5-year warranty cover on all appliances in this brochure

Access to exclusive models and ranges

Exclusive brand promotions and rewards

Exceptional service combined with kitchen design expertise



AEG

Premier Partner



5 year warranty available on
AEG Premier Partner core range
appliances as standard.



PEACE OF MIND, BUILT IN

All our appliances featured within this brochure are available through our AEG Premier Partner retailers and are covered by our extended five year parts and labour warranty. Your Premier Partner will register them on your behalf so you don't have to worry about a thing. During your warranty period you are protected against the cost of parts, call-out and labour charges.

All work is carried out by our national network of approved AEG engineers.



To find out more visit aeg.co.uk
or call **0800 479 0775**

YOUR JOURNEY STARTS HERE

Finding your nearest AEG Premier Partner couldn't be easier. Simply enter your postcode and you'll see our preferred kitchen studio partners closest to you.

Click on the link below and find your route to the exceptional.

[Find your nearest partner](#)

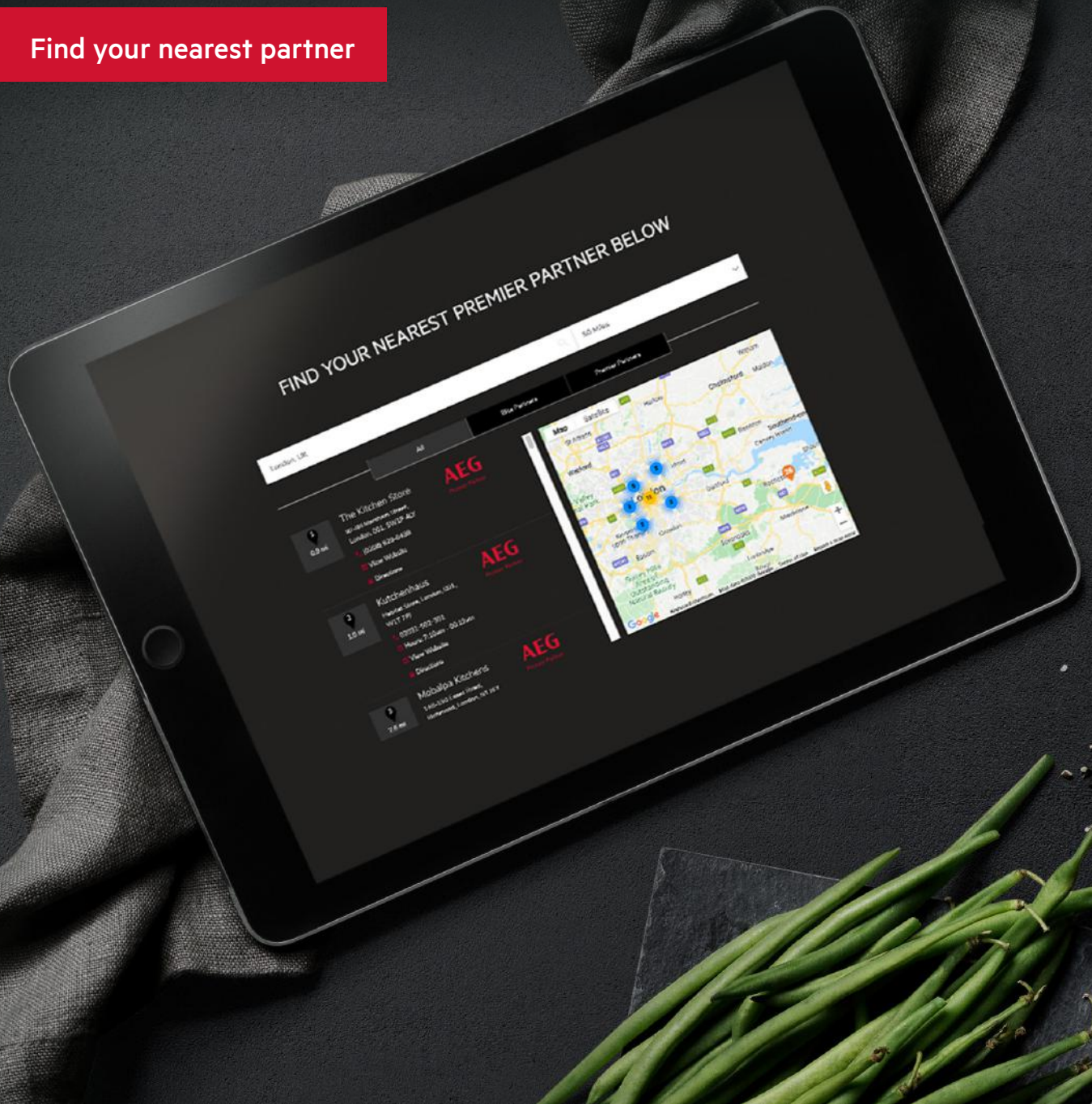

INNOVATIONS THAT PUSH THE BOUNDRIES IN YOUR KITCHEN

We know you already master your skills. We are here to help you take them even higher. With innovations that push the boundaries of what is achievable. And smart solutions engineered to learn and predict your needs and adapt to how you live.

We are relentless in developing better sustainable solutions, so you can raise your expectations. Because when we create responsible, built-to-last solutions, we also allow everyone who chooses AEG to make smarter choices for the environment. We always match sustainability with beauty and unparalleled performance, so you don't have to compromise.

It's time to forget outdated rules and trust your appliances.



HOB²HOOD



AEG

AEG



TWINTECH
NO FROST



SENSECOOK



SENSEPRO®

SLEEK. SEAMLESS. SUPERIOR

The Matt Black Collection from AEG brings together years of material engineering for an exclusive and premium execution. The quality of the materials are brought to life with architectural edges and tactile surfaces, with polished displays and interaction areas bringing new aesthetics and improved functionality to an increasingly sophisticated kitchen space.

INSPIRATION BEHIND THE DESIGN

“The matt glass fascia is created by an etching process, a technology from the architectural world. The matt texture has natural anti-fingerprint properties, which is tested to be much more resistant to stains and easier to clean, bringing an advanced level of performance.”

Terence Tan

Terence Tan, Senior Master Designer



AEG

AEG

AEG

AEG

AEG

Premier Partner
EXCLUSIVE



reddot winner 2021

MATT BLACK COLLECTION

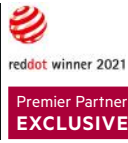

Connected Matt Black SteamPro Oven with Command Wheel

BSK993330T

KEY FEATURES

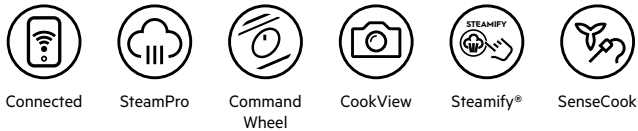

Connected Matt Black Multifunction Oven

BPK948330T

KEY FEATURES



OVEN FUNCTIONS

SousVide Cooking	Bottom Heat
Full Steam	Pizza Setting
Humidity High	Moist Fan Baking
Humidity Medium	Slow Cooking
Humidity Low	Defrost
True Fan Cooking	Au Gratin
Conventional Cooking	Bread Baking
Turbo Grilling	Dough Proving
Grilling	Steam Regeneration

OVEN FUNCTIONS

True Fan Cooking	Dough Proving
Conventional Cooking	Au Gratin
Turbo Grilling	Bread Baking
Grilling	Pyrolysis
Bottom Heat	
Pizza Setting	
Moist Fan Baking	
Defrost	
Slow Cooking	

Model Features

Steam cleaning	Quadruple door glazing
Enamel liners	Telescopic runners
Fully programmable timer	XXL baking tray
TFT display	Steam set
70 ltr oven capacity	Humidity sensor
Fast heat up	30°C – 230°C
Surround cook	

Model Features

Fully programmable timer	XXL baking tray
TFT display	XXL meat/grill pan
71 ltr oven capacity	30°C – 300°C
Fast heat up	
Double halogen lighting	
Telescopic runners	
Quadruple door glazing	

Energy Rating: A++

Appliance/Built-in Dimensions (HxWxD) in mm:

594 x 595 x 567 / 590 x 560 x 550

Energy Rating: A++

Appliance/Built-in Dimensions (HxWxD) in mm:

594 x 595 x 567 / 590 x 560 x 550



reddot winner 2021

Premier Partner
EXCLUSIVE

Connected Matt Black Oven with Command Wheel Control

KMK968000T

KEY FEATURES



Connected



Multifunction



Microwave



Command
Wheel



SurroundCook®

OVEN FUNCTIONS

- | | |
|----------------------|------------------|
| True Fan Cooking | Bread Baking |
| Conventional Cooking | Au Gratin |
| Turbo Grilling | Dough Proving |
| Grilling | Eco roasting |
| Bottom Heat | Slow Cooking |
| Pizza Setting | Microwave & Oven |
| Defrost | |
| Fast Grilling | |
| Microwave function | |

Model Features

Fully programmable timer	30°C – 230°C
White LED display	1000W microwave
43 ltr oven capacity	Glass microwave base plate
Single halogen lighting	
Triple door glazing	
XXL baking tray	
XXL meat/grill pan	

Appliance Dimensions

(HxWxD) in mm:

455 x 595 x 567

Built-in Dimensions

(HxWxD) in mm:

450 x 560 x 550

MATT BLACK COLLECTION



Matt Black Coffee Machine with Command Wheel Control

KKK994500T

FEATURES



Command Wheel



Authentic Italian Coffee



Fully Automatic



Uses Fresh Coffee Beans

OVEN FUNCTIONS

Espresso	Tea Water
Cappuccino	Latte Macchiato
Cappuccino Plus	Long Coffee
Caffè Latte	Warm Milk
Caffè Macchiato	Ristretto
Espresso Lungo	Steamer
Espresso Macchiato	Jug Function
Flat White	Two Cups

Model Features

Coffee jug	Water softener
Thermal milk container	2.4 ltr water tank
Descaler	400 gr grinder capacity
Cleaning brush	Quadruple LED lighting
Coffee powder spoon	
Telescopic runners + soft closing	

Appliance Dimensions (HxWxD) in mm:

455 x 595 x 361

Built-in Dimensions (HxWxD) in mm:

450 x 560 x 550

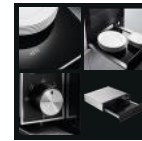

14cm Matt Black Warming Drawer

KDK911424T

KEY FEATURES



14cm



6 Place Settings



30-80°C Temp range

FUNCTIONS

Cups and Glass Warming (40°C)	Dough Proving (30°C)
Plate Warming (60°C)	Keep Warm (70°C)
Food Reheating (60°C – 80°C Max)	Defrosting (30°C Max)

Model Features

Variable temperature control	Rotary control knob
On/off LED	Heating element
Anti-slip mat	Fan air circulation

Appliance Dimensions (HxWxD) in mm:

140 x 595 x 535

Built-in Dimensions (HxWxD) in mm:

141 x 560 x 550



14cm Matt Black Vacuum Sealer

KDK911423T

KEY FEATURES



14cm



Touch Controls



White LEDs



3 Vacuum Settings

FUNCTIONS

Marinating/Infusion	Min. Vacuum setting
Max. Vacuum setting	Sealing time displayed
Med. Vacuum setting	

Appliance Dimensions

(HxWxD) in mm:

131 x 595 x 510

Built-in Dimensions

(HxWxD) in mm:

139 x 560 x 550

MATT BLACK COLLECTION



90cm Screen Wall Mounted Chimney Hood
with Dimmable LED Lighting and Touch Controls

DVK6981HR

KEY FEATURES



Touch on
Glass Controls



Hob2Hood



Dimmable LED
Strip Lighting

FUNCTIONS

5 Fan speeds

SilenceTech

Breeze Function

Additional Features

Charcoal filter included

Matt black chimney section
included

Motor speed: 750 m³/h

Noise: 43dB – 54dB

Energy Rating: A+

Dimensions (HxWxD) in mm: (1260-915) 380 x 896 x 456

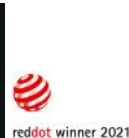

Matt Black 60/40 Freestanding Fridge Freezer
with TwinTech® NoFrost and Touch Control

RCB732E4MG

KEY FEATURES



TwinTech®
NoFrost



Touch Control



Soft Close
Doors



LED Lighting



Coolmatic



Frostmatic

FRIDGE FEATURES

Auto defrost

1 full width salad drawer

2 full width shelves

Egg tray: 2 for 8 eggs

FREEZER FEATURES

Auto defrost

2 full width and 1 half depth
drawers

DOOR FEATURES

Door open alarm

Reversible doors (right as default)

Capacity

Fridge:
230 ltr

Freezer:
101 ltr

Combined:
331 ltr

Additional Information

Annual energy consumption: 250kWh

Noise Rating: D

Noise Level: 42dB

Power cut safe rising time: 18h

Holiday mode: No

Colour

Black

Energy Rating: E

**Appliance Dimensions
(HxWxD) in mm:**

1860 x 595 x 662



18 Bottle Matt Black Compact Wine Cooler

KWK884520T

KEY FEATURES



Wine



Wine Temp



UV Glass



LED Lighting

FRIDGE FEATURES

2 full width shelves

DOOR FEATURES

Drop down opening

Capacity

18 bottles

Additional Information

Annual energy consumption: 100kWh

Noise Rating: C

Noise Level: 39dB

Electronic control

Minimum ambient temperature: 16°

Door fixing: BI Drop down

Energy Rating: F

Appliance Dimensions (HxWxD) in mm:

Unit: 455 x 595 x 566

Built-in: 450 x 560 x 550

REFRIGERATION

We design solutions to protect food quality so that people can enjoy a healthy diet and a sustainable life. We help consumers avoid food waste by protecting food quality. We work with circular, recyclable and conscious solutions and materials and reduce environmental footprint.



COLDSENSE

Flavour is all about freshness and storing ingredients – the right humidity and temperature is vital. But how do you want your fridge arranged?

Our solution lets you decide. Everything and anything fits in perfectly for long-lasting flavour, while maintaining energy efficiency, protecting your environment and your budget.



TWINTECH® NOFROST

Our Zero Degree compartments make it possible to create different chilling conditions in each part of your refrigerator. Adjust each drawer's temperature at a touch.



GREENZONE

IN THIS SECTION

Integrated Fridge Freezers

Integrated Fridges and Freezers

Freestanding Fridge Freezers

Wine Cooling



COOL ON EVERY LEVEL



TwinTech® NoFrost

Unlike conventional fridge freezers that use cold, ultra-dry air from the freezer and recirculate it to cool the fridge, TwinTech® NoFrost units have two separate cooling systems. This provides the ideal humidity in each compartment, preventing food from drying out in the fridge and delivering frost-free storage in the freezer.

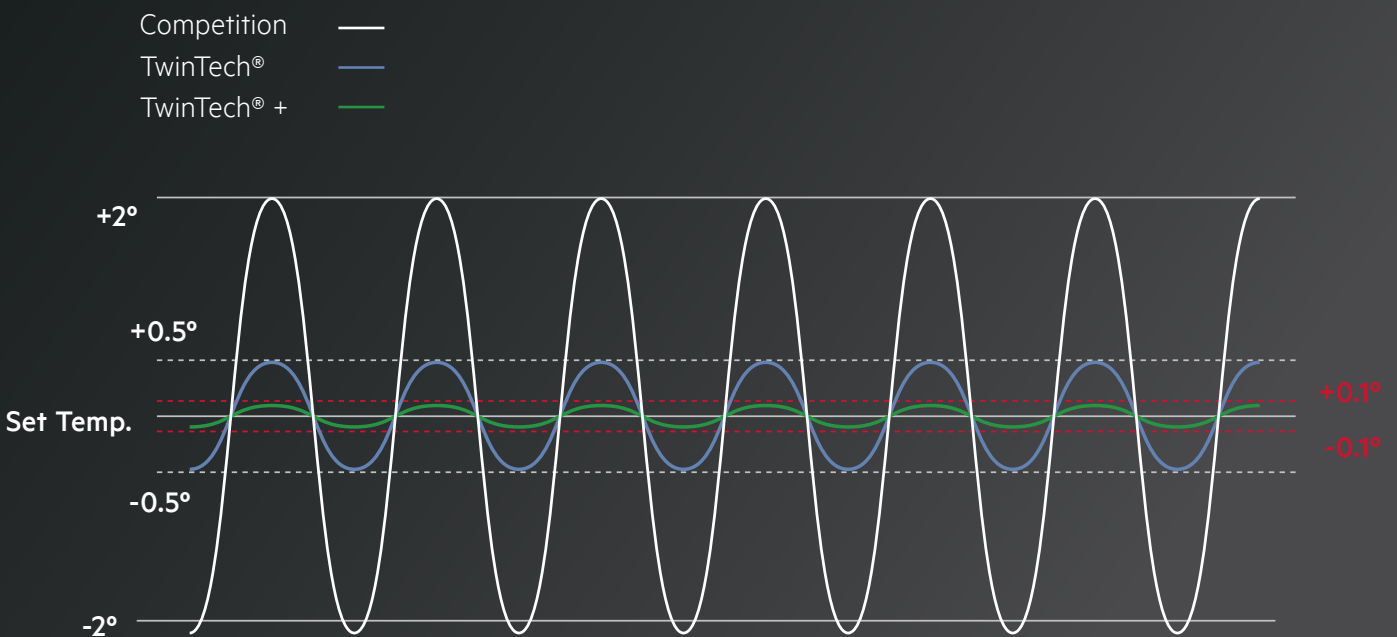



DynamicAir

DynamicAir technology maintains the airflow inside the fridge, ensuring a consistent temperature at every shelf so that your ingredients stay fresh.

With NoFrost

Without NoFrost



NoFrost

Never defrost your freezer again. NoFrost freezers offer efficient and effective freezing with quicker, more even freezing for better food preservation.

With LongFresh

Without LongFresh

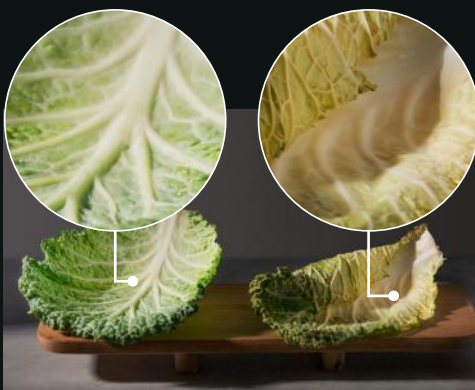

LongFresh

The LongFresh feature is a Zero Degree compartment with adjustable temperature settings and separate humidity. The two Zero Degree compartments in the AEG refrigerator allow you to choose and adjust the humidity and temperature settings in each drawer.

ADAPTABLE FOR EVERY TASTE



CustomFlex®

Create your own perfectly organised fridge with the CustomFlex® storage system. This unique and practical inner door system allows you to arrange shelves, clips and compartments in all shapes and sizes in hundreds of different layouts, so there's always one that works best for you at any time.





LED Touch Display

Touch controls with new white LED digital display.



High Efficiency LED Lighting

LED lighting ensures a good spread of light shines downwards in the fridge. An intelligent fan function prevents warm areas in the upper part of the fridge and creates an even temperature in all fridge levels, even freezing for better food preservation.



Self-Closing Door

An elegant solution, with no risk of slamming. Automatically closes from an opening angle of 25–30 degrees.

REFRIGERATION ICONS

KEY FEATURES GUIDE



TwinTech® NoFrost

Pioneering TwinTech® NoFrost technology for exceptional freshness. One cooling system chills the freezer, keeping it NoFrost. The other cools the fridge, ensuring that the fridge temperature is cold, stable and with the correct level of humidity, so as not to dry out your fruit and vegetables.



Frostmatic

Ideal for freezing fresh food quickly, preserving the flavour, colour, texture and nutritional value.



Multi Air Flow

The Multi Air Flow technology provides the precise temperature and humidity your ingredients need to stay fresh in your fridge, nutritious and full of flavour for even longer.



CustomFlex®

Keeping all your fresh ingredients to hand is key to creating fresh, delicious dishes. Now the CustomFlex® refrigerator from AEG lets you organise your fridge storage just the way you want.



LCD Touch Display

Sleek touch controls that are intuitive and ready to use.



Ice & Water

Dispenser through the door for water and ice cubes.



High Temperature Alarm

Highlights an increase in the temperature in the freezer compartment.



NoFrost

Never defrost your freezer again. NoFrost freezers offer efficient and effective freezing with quicker, more even freezing for better food preservation.



LowFrost

Faster, more efficient defrosting. Time is of the essence when defrosting your freezer. This fridge freezer comes with efficient LowFrost technology, which makes the defrosting faster and less frequent than ever before.



LongFresh

The LongFresh feature is a Zero Degree compartment with adjustable temperature settings and separate humidity. The two Zero Degree compartments in the AEG refrigerator allow you to choose and adjust the humidity and temperature settings in each drawer.



Touch Control

Intuitive touch controls provide instant feedback, are easy to use and look sleek in the kitchen.



Soft Close Doors

Soft Close door hinges that automatically close from an angle of 23–30 degrees – providing an elegant solution to slamming doors.



LED Lighting

Premium and modern lighting system in the fridge thanks to the bright LED light with rise-on effect.



GreenZone

Dedicated drawer which allows you to precisely control the humidity, so you can preserve the flavours and nutrients of your fresh fruits and vegetables.



Coolmatic

Ideal for chilling fresh food quickly and regaining a stable temperature within the fridge once the door has been opened, maintaining food freshness.



DynamicAir

DynamicAir technology maintains the airflow inside the fridge, ensuring a consistent temperature at every shelf so that your ingredients stay fresh.



UltraFresh+

Automatic humidity control and antioxidant release filter inside the fridge compartment, keeping fruit and vegetables market fresh.



MultiSpace

No compromise between kitchen dimensions and your storage requirements. More storage capacity than a standard built-in model for improved organization and flexibility.



SpinView

The revolutionary solution for easy access to those hard to reach items. SpinView rotates with one touch in both directions, allowing full accessibility to the back of the shelf with minimum effort.



MultiSwitch

Fully convertible middle drawer ranging from -18 to +7 degrees. Provides optimal environment for any type of food.



Simple Touch Controls

Our simple to use electronic controls, with Frostmatic function, ensure that you can set the fridge freezer to your desired temperature.

REFRIGERATION

INTEGRATED FRIDGE FREEZERS



70/30 with TwinTech® NoFrost and CustomFlex®
SCE818C5TC

KEY FEATURES



TwinTech®
NoFrost



CustomFlex®



Soft Close Doors



DynamicAir



Touch Control



LED Lighting



Coolmatic



Frostmatic



High Temperature
Alarm

FRIDGE FEATURES

Auto defrost

3 full width + flexi shelf

2 half width salad drawers

Dairy compartment with lid

1 half width sliding door shelf

Egg tray: 2 for 6 eggs

FREEZER FEATURES

Auto defrost

3 full width drawers

DOOR FEATURES

Door open alarm

Reversible doors (right as default)

Capacity

Fridge:

184 ltr

Freezer:

61 ltr

Combined:

245 ltr

Additional Information

Annual energy consumption: 137kWh

Noise Rating: B

Noise Level: 35dB

Power cut safe rising time: 23h

Holiday mode: Yes

Door fixing: BI DoD

Colour

White

Energy Rating: C

Appliance Dimensions (HxWxD) in mm:

Combined: 1769 x 556 x 549

Built-in: 1780 x 560 x 550



70/30 with TwinTech® NoFrost and CustomFlex®
SCE818E5TC

KEY FEATURES



TwinTech®
NoFrost



CustomFlex®



Soft Close Doors



Touch Control



LED Lighting



Coolmatic



Frostmatic



High Temperature
Alarm

FRIDGE FEATURES

Auto defrost

3 full width + flexi shelf

2 half width salad drawers

Dairy compartment with lid

Egg tray: 2 for 6 eggs

FREEZER FEATURES

Auto defrost

3 full width drawers

DOOR FEATURES

Door open alarm

Reversible doors (right as default)

Capacity

Fridge:

184 ltr

Freezer:

61 ltr

Combined:

245 ltr

Additional Information

Annual energy consumption: 214kWh

Noise Rating: C

Noise Level: 37dB

Power cut safe rising time: 23h

Holiday mode: Yes

Door fixing: BI DoD

Colour

White

Energy Rating: E

Appliance Dimensions (HxWxD) in mm:

Combined: 1769 x 556 x 549

Built-in: 1780 x 560 x 550

REFRIGERATION

INTEGRATED SUPER TALL FRIDGE FREEZERS



70/30 with TwinTech® NoFrost and CustomFlex®
SCE819E5TS

70/30 with CustomFlex® and SpinView
SCE819E7TS

KEY FEATURES

KEY FEATURES

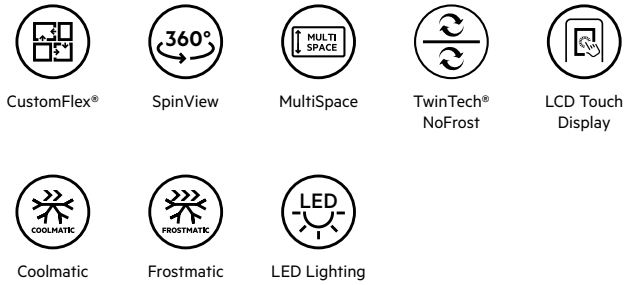
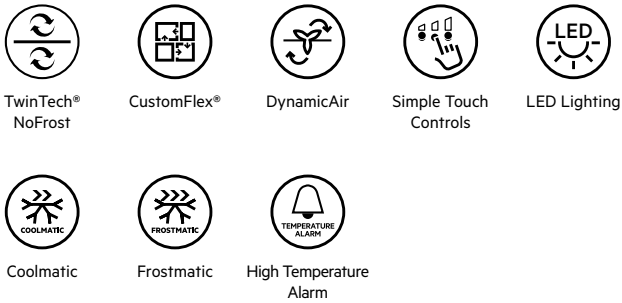

FRIDGE FEATURES

Auto defrost
3 full width + flexi shelf
Fresh box
Dairy compartment with lid
1 half width sliding door shelf
Egg tray: 2 for 6 eggs

FREEZER FEATURES

Auto defrost
3 full width drawers
DOOR FEATURES
Reversible doors (right as default)

FRIDGE FEATURES

Auto defrost
3 full width + flexi shelf
Fresh box
Dairy compartment with lid
Egg tray: 1 for 10 eggs

FREEZER FEATURES

Auto defrost
3 full width drawers
DOOR FEATURES
Reversible doors (right as default)

Capacity

Fridge:
208 ltr
Freezer:
61 ltr
Combined:
269 ltr

Additional Information

Annual energy consumption: 214kWh
Noise Rating: C
Noise Level: 36dB
Power cut safe rising time: 21h
Holiday mode: Yes
Door fixing: BI slide door

Colour
White

Energy Rating: C

Appliance Dimensions (HxWxD) in mm:
Combined: 1884 x 540 x 549
Built-in: 1898 x 556 x 549

Capacity

Fridge:
208 ltr
Freezer:
61 ltr
Combined:
269 ltr

Additional Information

Annual energy consumption: 214kWh
Noise Rating: C
Noise Level: 36dB
Power cut safe rising time: 21h
Holiday mode: Yes
Door fixing: BI slide door

Colour
White

Energy Rating: E

Appliance Dimensions (HxWxD) in mm:
Combined: 1884 x 540 x 549
Built-in: 1898 x 556 x 549



70/30 with TwinTech® NoFrost and Touch Control
SCE818E8TS

KEY FEATURES



TwinTech®
NoFrost



Touch Control



DynamicAir



LED Lighting



Coolmatic



Frostmatic



High Temperature
Alarm



GreenZone



70/30 with TwinTech® NoFrost and Soft Close Doors
SCE818E6TC

KEY FEATURES



TwinTech®
NoFrost



Soft Close Doors



Touch Control



LED Lighting



Coolmatic



Frostmatic



High Temperature
Alarm

FRIDGE FEATURES

Auto defrost

3 full width + flexi shelf

1 full width salad drawer

Dairy compartment with lid

Egg tray: 2 for 6 eggs

FREEZER FEATURES

Auto defrost

3 full width drawers

DOOR FEATURES

Door open alarm

Reversible doors (right as default)

FRIDGE FEATURES

Auto defrost

3 full width + flexi shelf

2 half width salad drawers

Dairy compartment with lid

1 half width sliding door shelf

Egg tray: 2 for 6 eggs

FREEZER FEATURES

Auto defrost

3 full width drawers

DOOR FEATURES

Door open alarm

Reversible doors (right as default)

Capacity

Fridge:
193 ltr

Freezer:
61 ltr

Combined:
254 ltr

Additional Information

Annual energy consumption: 214kWh

Noise Rating: B

Noise Level: 35dB

Power cut safe rising time: 21h

Holiday mode: Yes

Door fixing: BI Slide Door

Colour

White

Energy Rating: E

Appliance Dimensions (HxWxD) in mm:

Combined: 1772 x 540 x 549

Built-in: 1780 x 560 x 550

Capacity

Fridge:
187 ltr

Freezer:
61 ltr

Combined:
248 ltr

Additional Information

Annual energy consumption: 214kWh

Noise Rating: C

Noise Level: 37dB

Power cut safe rising time: 23h

Holiday mode: Yes

Door fixing: BI DoD

Colour

White

Energy Rating: E

Appliance Dimensions (HxWxD) in mm:

Combined: 1769 x 556 x 549

Built-in: 1780 x 560 x 550

REFRIGERATION

INTEGRATED FRIDGE FREEZERS



50/50 with TwinTech® NoFrost and Touch Control
SCE818E6NS

KEY FEATURES



TwinTech®
NoFrost



Touch Control



DynamicAir



LED Lighting



Coolmatic



Frostmatic



High Temperature
Alarm



50/50 with TwinTech® NoFrost and Touch Control
SCE818F6NS

KEY FEATURES



TwinTech®
NoFrost



Touch Control



LED Lighting



Coolmatic



Frostmatic



High Temperature
Alarm

FRIDGE FEATURES

Auto defrost

2 full width + flexi shelf

2 half width salad drawers

Dairy compartment with lid

1 half width sliding door shelf

Egg tray: 2 for 6 eggs

FREEZER FEATURES

Auto defrost

4 full width drawers

DOOR FEATURES

Door open alarm

Reversible doors (right as default)

FRIDGE FEATURES

Auto defrost

2 full width + flexi shelf

2 half width salad drawers

Dairy compartment with lid

1 half width sliding door shelf

Egg tray: 2 for 6 eggs

FREEZER FEATURES

Auto defrost

4 full width drawers

DOOR FEATURES

Door open alarm

Reversible doors (right as default)

Capacity

Fridge:
153 ltr

Freezer:
87 ltr

Combined:
240 ltr

Additional Information

Annual energy consumption: 235kWh

Noise Rating: C

Noise Level: 36dB

Power cut safe rising time: 25h

Holiday mode: Yes

Door fixing: BI slide door

Colour

White

Energy Rating: E

Appliance Dimensions (HxWxD) in mm:

Combined: 1772 x 540 x 549

Built-in: 1780 x 560 x 550

Capacity

Fridge:
153 ltr

Freezer:
87 ltr

Combined:
240 ltr

Additional Information

Annual energy consumption: 293kWh

Noise Rating: C

Noise Level: 36dB

Power cut safe rising time: 24h

Holiday mode: Yes

Door fixing: BI slide door

Colour

White

Energy Rating: F

Appliance Dimensions (HxWxD) in mm:

Combined: 1772 x 540 x 549

Built-in: 1780 x 560 x 550



70/30 with TwinTech® NoFrost and Touch Control

SCE818F6TS

KEY FEATURES



TwinTech®
NoFrost



Touch Control



DynamicAir



LED Lighting



Coolmatic



Frostmatic



High Temperature
Alarm

FRIDGE FEATURES

Auto defrost

3 full width + flexi shelf

2 half width salad drawers

Dairy compartment with lid

1 half width sliding door shelf

Egg tray: 2 for 6 eggs

FREEZER FEATURES

Auto defrost

3 full width drawers

DOOR FEATURES

Door open alarm

Reversible doors (right as default)

Capacity

Fridge:

193 ltr

Freezer:

61 ltr

Combined:

254 ltr

Additional Information

Annual energy consumption: 268kWh

Noise Rating: C

Noise Level: 38dB

Power cut safe rising time: 21h

Holiday mode: Yes

Door fixing: BI Slide Door

Colour

White

Energy Rating: F

Appliance Dimensions (HxWxD) in mm:

Combined: 1772 x 540 x 549

Built-in: 1780 x 560 x 550

REFRIGERATION

INTEGRATED FRIDGE FREEZERS



70/30 LowFrost with Simple Touch Controls
SCB618F3LS

KEY FEATURES



LowFrost



Simple Touch Control



LED Lighting



Frostmatic



50/50 LowFrost with Simple Touch Controls
SCB718F3LS

KEY FEATURES



LowFrost



Simple Touch Control



LED Lighting



Frostmatic

FRIDGE FEATURES

Auto defrost

4 full width + flexi shelf

2 half width salad drawers

Dairy compartment with lid

Egg tray: 2 for 6 eggs

FREEZER FEATURES

Manual defrost

3 full width drawers

DOOR FEATURES

Reversible doors (right as default)

FRIDGE FEATURES

Auto defrost

3 full width + flexi shelf

2 half width salad drawers

Dairy compartment with lid

1 half width sliding door shelf

Egg tray: 2 for 6 eggs

FREEZER FEATURES

Manual defrost

4 full width drawers

DOOR FEATURES

Reversible doors (right as default)

Capacity

Fridge:
196 ltr

Freezer:
72 ltr

Combined:
268 ltr

Additional Information

Annual energy consumption: 272kWh
Noise Rating: B
Noise Level: 35dB
Power cut safe rising time: 22h
Holiday mode: Yes
Door fixing: BI slide door

Colour

White

Energy Rating: F

Appliance Dimensions (HxWxD) in mm:

Combined: 1772 x 540 x 549
Built-in: 1780 x 560 x 550

Capacity

Fridge:
161 ltr

Freezer:
106 ltr

Combined:
267 ltr

Additional Information

Annual energy consumption: 289kWh
Noise Rating: C
Noise Level: 36dB
Power cut safe rising time: 22h
Door fixing: BI slide door

Colour

White

Energy Rating: F

Appliance Dimensions (HxWxD) in mm:

Combined: 1772 x 540 x 549
Built-in: 1780 x 560 x 550



70/30 Mini 1446mm LowFrost with LED Lighting

SCB614F1LS

KEY FEATURES



LowFrost



LED Lighting

FRIDGE FEATURES

Auto defrost

3 full width + flexi shelf

2 half width salad drawers

Dairy compartment with lid

1 half width sliding door shelf

Egg tray: 2 for 6 eggs

FREEZER FEATURES

Manual defrost

2 full width drawers

DOOR FEATURES

Reversible doors (right as default)

Capacity

Fridge:
160 ltr

Freezer:
57 ltr

Combined:
217 ltr

Additional Information

Annual energy consumption: 253kW

Noise Rating: B

Noise Level: 35dB

Power cut safe rising time: 20h

Door fixing: BI Slide Door

Simple electronic control

Colour

White

Energy Rating: F

Appliance Dimensions

(HxWxD) in mm:

Combined: 1441 x 540 x 549

Built-in: 1446 x 560 x 540

REFRIGERATION

INTEGRATED UNDER COUNTER FREEZERS



NoFrost Freezer with Simple Touch Controls

Freezer with Simple Touch Controls

ABE682F1NF

ABB682F1AF

KEY FEATURES

KEY FEATURES



No Frost



Simple Touch Controls



Frostmatic



High Temperature Alarm



Simple Touch Controls



Frostmatic



High Temperature Alarm

FREEZER FEATURES

DOOR FEATURES

FREEZER FEATURES

DOOR FEATURES

- Auto defrost
- 3 full width drawers
- Telescopic freezer drawers

- Door open alarm
- Reversible doors (right as default)

- Manual defrost
- 3 full width drawers

- Door open alarm
- Reversible doors (right as default)

Capacity

Freezer:
85 ltr

Additional Information

Annual energy consumption: 237kWh
Noise Rating: D
Noise Level: 43dB
Power cut safe rising time: 13h
Door fixing: BI UC DoD

Colour

White

Energy Rating: F

Appliance Dimensions (HxWxD) in mm:

Unit: 815 x 596 x 550
Built-in: 820 x 600 x 550

Capacity

Freezer:
95 ltr

Additional Information

Annual energy consumption: 220kWh
Noise Rating: C
Noise Level: 39dB
Power cut safe rising time: 21h
Door fixing: BI UC DoD

Colour

White

Energy Rating: F

Appliance Dimensions (HxWxD) in mm:

Unit: 815 x 596 x 550
Built-in: 820 x 600 x 550



Fridge with Freezer Compartment and LED Lighting
SFB682F1AF

KEY FEATURES



LED Lighting

FRIDGE FEATURES

Auto defrost
2 full width glass shelves
1 full width salad drawer
Dairy compartment with lid
1 half width sliding door shelf
Egg tray: 1 for 6 eggs

Capacity

Fridge:
94 ltr

Ice box:
16 ltr

Energy Rating: F

DOOR FEATURES

Reversible doors (right as default)

Additional Information

Annual energy consumption: 185kWh
Noise Rating: C
Noise Level: 38dB
Power cut safe rising time: 11h
Door fixing: BI UC DoD
Mechanical control

Colour

White

Appliance Dimensions (HxWxD) in mm:

Unit: 815 x 596 x 550
Built-in: 820 x 600 x 550



Fridge with LED Lighting
SKB582F1AF

KEY FEATURES



LED Lighting

FRIDGE FEATURES

Auto defrost
3 full width glass shelves
1 full width salad drawer
Dairy compartment with lid
1 half width sliding door shelf
Egg tray: 1 for 6 eggs

Capacity

Fridge:
134 ltr

Energy Rating: F

DOOR FEATURES

Reversible doors (right as default)

Additional Information

Annual energy consumption: 116kWh
Noise Rating: C
Noise Level: 37dB
Door fixing: BI UC DoD
Mechanical control

Colour

White

Appliance Dimensions (HxWxD) in mm:

Unit: 815 x 596 x 550
Built-in: 820 x 600 x 550

REFRIGERATION

INTEGRATED FREEZERS



1780mm NoFrost with Touch Controls and Soft Close Doors
ABK818E6NC

KEY FEATURES



FREEZER FEATURES

Auto defrost
5 full width drawers

DOOR FEATURES

Door open alarm
Reversible doors (right as default)

Capacity

Freezer:
204 ltr

Additional Information

Annual energy consumption: 233kWh
Noise Rating: C
Noise Level: 39dB
Power cut safe rising time: 24h
Door fixing: BI DoD

Colour
White

Energy Rating: E

Appliance Dimensions (HxWxD) in mm:
Unit: 1769 x 556 x 549
Built-in: 1780 x 560 x 550



1225mm NoFrost with Touch Controls and Soft Close Doors
ABB812E6NC

KEY FEATURES



FREEZER FEATURES

Auto defrost
4 full width drawers

DOOR FEATURES

Door open alarm
Reversible doors (right as default)

Capacity

Freezer:
122 ltr

Additional Information

Annual energy consumption: 203kWh
Noise Rating: C
Noise Level: 40dB
Power cut safe rising time: 22h
Door fixing: BI DoD

Colour
White

Energy Rating: E

Appliance Dimensions (HxWxD) in mm:
Unit: 1224 x 556 x 549
Built-in: 1225 x 556 x 550



REFRIGERATION

INTEGRATED FRIDGES



1780mm with LongFresh and Soft Close Doors

SKK818E9ZC

KEY FEATURES



LongFresh



Soft Close Doors



Touch Control



LED Lighting



Coolmatic

FRIDGE FEATURES

Auto defrost

3 full width + flexi shelf

Dairy compartment with lid

1 half width sliding door shelf

Egg tray: 2 for 6 eggs

DOOR FEATURES

Door open alarm

Reversible doors (right as default)

Capacity

Fridge:
276 ltr

Additional Information

Annual energy consumption: 148kWh
Noise Rating: C
Noise Level: 37dB
Door fixing: BI DoD

Colour

White

Energy Rating: E

Appliance Dimensions (HxWxD) in mm:

Unit: 1769 x 556 x 549
Built-in: 1780 x 560 x 550



LongFresh

The LongFresh feature is a Zero Degree compartment with adjustable temperature settings and separate humidity. To maintain the deep blushing crimson of a fillet of beef, to ensure the sweet freshness of a lobster tail, or to hold the ultimate flavour of fresh fruit they must be treated and chilled with precision. The two Zero Degree compartments in the AEG refrigerator allow you to choose and adjust the humidity and temperature settings in each drawer. Ensure that each element is at peak condition, by chilling them in unique conditions.



1780mm with Soft Close Doors and Touch Control
SKE818E1DC

KEY FEATURES



Soft Close Doors



Touch Control



DynamicAir



LED Lighting



Coolmatic



1225mm with Soft Close Doors and Touch Control
SKB812F1AC

KEY FEATURES



Soft Close Doors



Touch Control



LED Lighting



Coolmatic

FRIDGE FEATURES

- Auto defrost
- 4 full width + flexi shelf
- 1 drawer divider fresh box
- Dairy compartment with lid
- 1 half width sliding door shelf
- Egg tray: 2 for 6 eggs

DOOR FEATURES

- Door open alarm
- Reversible doors (right as default)

Capacity

Fridge:
311 ltr

Additional Information

Annual energy consumption: 114kWh
Noise Rating: B
Noise Level: 35dB
Holiday mode: Yes
Door fixing: BI DoD

Colour

White

Energy Rating: E

Appliance Dimensions (HxWxD) in mm:

Unit: 1769 x 556 x 549
Built-in: 1780 x 560 x 55

FRIDGE FEATURES

- Auto defrost
- 3 full width + flexi shelf
- 2 half width salad drawers
- Dairy compartment with lid
- 1 half width sliding door shelf
- Egg tray: 2 for 6 eggs

DOOR FEATURES

- Door open alarm
- Reversible doors (right as default)

Capacity

Fridge
203 ltr

Additional Information

Annual energy consumption: 126kWh
Noise Rating: C
Noise Level: 36dB
Holiday mode: Yes
Door fixing: BI DoD

Colour

White

Energy Rating: F

Appliance Dimensions (HxWxD) in mm:

Unit: 1219 x 556 x 550
Built-in: 1225 x 560 x 550

REFRIGERATION

FREESTANDING FRIDGE FREEZER



Matt Black 60/40 with TwinTech® NoFrost and Touch Control
RCB732E4MG

KEY FEATURES

- TwinTech® NoFrost
- Touch Control
- Soft Close Doors
- LED Lighting
- Coolmatic
- Frostmatic

FRIDGE FEATURES

- Auto defrost
- 2 full width shelves
- 1 full width salad drawer
- Egg tray: 2 for 8 eggs

FREEZER FEATURES

- Auto defrost
- 2 full width and 1 half depth drawers
- DOOR FEATURES**
- Door open alarm
- Reversible doors (right as default)

Capacity

- Fridge:** 230 ltr
- Freezer:** 101 ltr
- Combined:** 331 ltr

Additional Information

- Annual energy consumption: 250kWh
- Noise Rating: D
- Noise Level: 42dB
- Power cut safe rising time: 18h
- Holiday mode: No

Colour
Black

Energy Rating: E

Appliance Dimensions (HxWxD) in mm:
1860 x 595 x 662

FREESTANDING AMERICAN STYLE & FRENCH DOOR



French Door TwinTech® NoFrost with Multi Switch Drawer
RMB954F9VX

KEY FEATURES

- TwinTech® NoFrost
- MultiSwitch
- Multi Air Flow
- CustomFlex®
- Connectivity Ready
- Ice & Water

FRIDGE FEATURES

- Auto defrost
- 1 full width + flexi shelf
- 2 half width salad drawers
- Dairy compartment with lid
- 1 half width sliding door shelf
- Egg tray: 1 for 12 eggs

Capacity

- Fridge:** 378 ltr
- Freezer:** 239 ltr
- Combined:** 617 ltr

FREEZER FEATURES

- Auto defrost
- 2 full width drawers
- DOOR FEATURES**
- Door open alarm
- Left & right door opening
- MultiSwitch drawer

Additional Information

- Annual energy consumption: 412kWh
- Noise Rating: D
- Noise Level: 42dB
- Plumbed

Colour
Stainless steel

Energy Rating: F

Appliance Dimensions (HxWxD) in mm:
1780 x 912 x 758



Side by Side TwinTech® NoFrost with Ice & Water Dispenser
RMB76121NX

KEY FEATURES



TwinTech®
NoFrost



Ice & Water



Multi Air Flow



LCD Touch
Display



LED Lighting



Coolmatic



Frostmatic



High Temperature
Alarm

FRIDGE FEATURES

Auto defrost

4 full width glass shelves

Fresh box

Large pull out salad drawer

Dairy compartment with lid

Egg tray

FREEZER FEATURES

Auto defrost

2 full width drawers

DOOR FEATURES

Door open alarm

Side by side door opening

2 shelves

Capacity

Fridge:

370 ltr

Freezer:

179 ltr

Combined:

549 ltr

Additional Information

Annual energy consumption: 390kWh

Noise Rating: D

Noise Level: 44dB

Power cut safe rising time: 10h

Holiday mode: Yes

Plumbed

Colour

Stainless steel

Energy Rating: F

Appliance Dimensions

(HxWxD) in mm:

1780 x 912 x 738

WINE COOLING

Our Wine Cellar Range has dedicated technology for optimal wine storage, to store your wine bottles at the perfect temperature throughout the cooler.

Our wine cellars have a single temperature zone with a range of 5–20, providing the perfect environment for your wine. The UV protected glass door helps to protect your wine from light damage and our internal fan ensures a stable, consistent temperature.

16

08



WINE COOLING

UNDERCOUNTER WINE COOLERS



46 Bottle Wine Cooler
AWUS052B5B

KEY FEATURES



FRIDGE FEATURES

6 full width glass shelves

DOOR FEATURES

Reversible doors (right as default)

Capacity

46 bottles

Additional Information

Annual energy consumption: 148kWh
Noise Rating: D
Noise Level: 42dB
Minimum ambient temperature: 16°
Door fixing: BI wide door

Energy Rating: G

Appliance Dimensions (HxWxD) in mm:

Unit: 820 x 595 x 565
Built-in: 822 x 600 x 550



20 Bottle Wine Cooler
AWUS020B5B

KEY FEATURES



FRIDGE FEATURES

6 full width glass shelves

DOOR FEATURES

Reversible doors (right as default)

Capacity

20 bottles

Additional Information

Annual energy consumption: 137kWh
Noise Rating: D
Noise Level: 42dB
Minimum ambient temperature: 16°
Door fixing: BI wide door

Energy Rating: G

Appliance Dimensions (HxWxD) in mm:

Unit: 820 x 294 x 571
Built-in: 822 x 300 x 550

COMPACT WINE COOLERS



18 Bottle Matt Black Wine Cooler
KWK884520T

18 Bottle Wine Cooler
KWK884520M

KEY FEATURES

KEY FEATURES

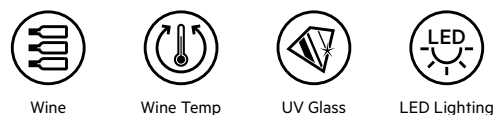
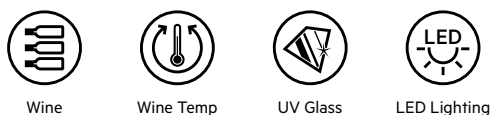

FRIDGE FEATURES

DOOR FEATURES

2 full width shelves

Drop down opening

FRIDGE FEATURES

DOOR FEATURES

2 full width shelves

Drop down opening

Capacity

18 bottles

Additional Information

Annual energy consumption: 100kWh
Noise Rating: C
Noise Level: 39dB
Electronic control
Minimum ambient temperature: 16°
Door fixing: BI Drop down

Capacity

18 bottles

Additional Information

Annual energy consumption: 100kWh
Noise Rating: C
Noise Level: 39dB
Electronic control
Minimum ambient temperature: 16°
Door fixing: BI Drop down

Energy Rating: F

Appliance Dimensions (HxWxD) in mm:

Unit: 455 x 595 x 566
Built-in: 450 x 560 x 550

Energy Rating: F

Appliance Dimensions (HxWxD) in mm:

Unit: 455 x 595 x 566
Built-in: 450 x 560 x 550

OVENS

Our solutions help you expand your skills in the kitchen and take taste further.

We encourage curiosity and explore new ingredients and techniques that exceed expectations, while also pushing the standards of healthy and sustainable cooking.

However you like to cook and whatever your favourite dishes, there's an AEG oven that's just right for you.

Featuring our intelligent technology, every oven makes it effortless and enjoyable to create great tasting food, exactly the way you like it.

IN THIS SECTION

Connected Cooking

Single Ovens

Built-In Double Ovens

Built-Under Double Oven

Compacts

Microwave Ovens

Blackline Range





COMMAND WHEEL
OVEN CONTROL



STEAMPRO



SOUSVIDE
COOKING



GREAT TASTE, AT YOUR COMMAND

Order from your oven with Command Wheel the way you would at a restaurant. Select rare, medium or well done to enjoy perfect results at home without ever dealing with degrees. Why compromise on an oven that doesn't live up to your standards.



Command Wheel

An innovative Command Wheel removes the need for a busy dashboard and makes the cooking experience simple and streamlined for perfection on a plate, every time.



Connected

Easily monitor and set your oven programmes with our AEG App. This allows you to adjust cooking programmes, follow step by step recipes, and even allows you to set cooking programmes based on relevant recipes.

The latest furniture trends are becoming more linear and we have designed our products in line with that. We've also included more glass and less stainless steel for a seamless finish.





SenseCook

By precisely measuring the core temperature of your food, the Food Sensor lets you know when your rare, medium or well done meat is ready. It also allows you to cook fish, casseroles and vegetables just the way you like them.

Without SurroundCook® With SurroundCook®

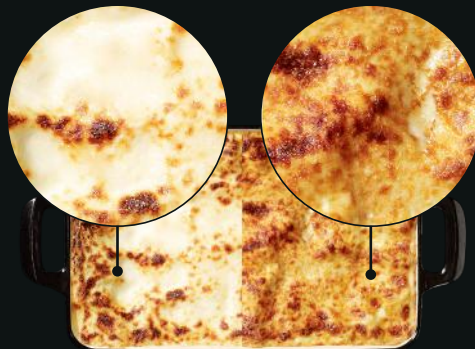

SurroundCook®

Expect even, every time with SurroundCook®. Every part of your dish receives the exact consistent heat that it needs.



Pyrolytic Self Cleaning

A total self-cleaning function that automatically locks the oven door and heats up to 500°C, turning food residue to ash.

WELCOME TO THE SMART KITCHEN

EXPERIENCE OUR INTELLIGENT SOLUTIONS

Get the most out of your experience by connecting your AEG appliances. Our smart products make your everyday tasks both easier and more convenient. You are able to adapt your appliances with your personal preferences via remote monitoring and control. .



My AEG Kitchen App *

To ensure peace of mind whilst owning an AEG appliance download the My AEG Kitchen App. Within the App you'll find user-friendly guides, help to set up your connected oven and the ability to register your product guarantee with ease.

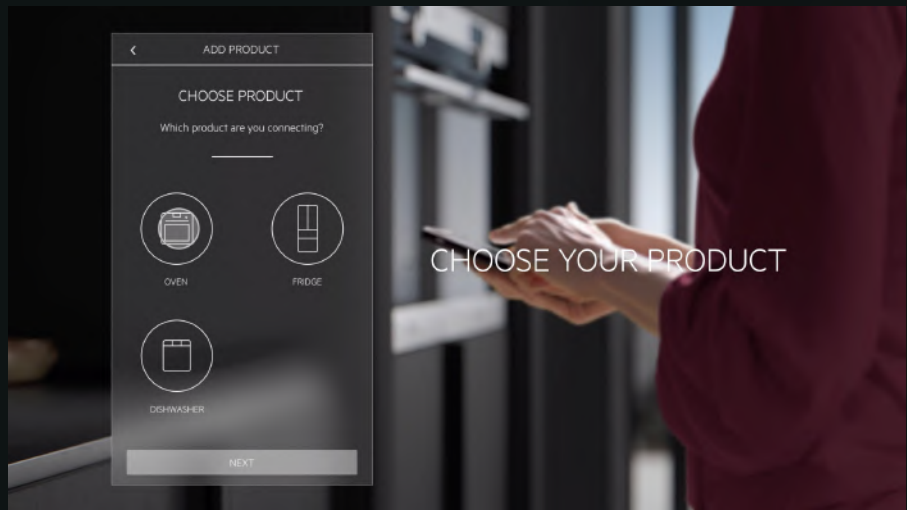

Remote Monitor

Monitor the progress of your food whilst it cooks. You can easily check how your favourite dish is coming along through your smartphone whilst you're away from your oven.

Remote Control

It's simple to start & end the cooking program remotely through your smartphone and if you think the temperature needs adjusting then you can do this simply too.

Send a recipe to your oven

You can send your favourite recipe with its settings directly to your oven via the My AEG Kitchen App and your oven will take care of cooking it to perfection.



Download the 'My AEG kitchen App' on the App Store or get it on Google Play.

*Film shown above is for 'My AEG kitchen App' connection using Apple devices, please click the link for 'My AEG kitchen App' connection using Android devices.

**Your WiFi network frequency must be 2.4 GHz.



Hey Google turn my oven down by 20°C

Sure, reducing oven temperature by 20°C



Google Assistant

Your AEG WiFi** connected oven works closely with connected devices such as the Google Home Mini to really help you excel in the kitchen.

Google Assistant allows you to control your oven with your voice, so if your hands are covered in flour but you want to turn the oven down, just ask it to do so!

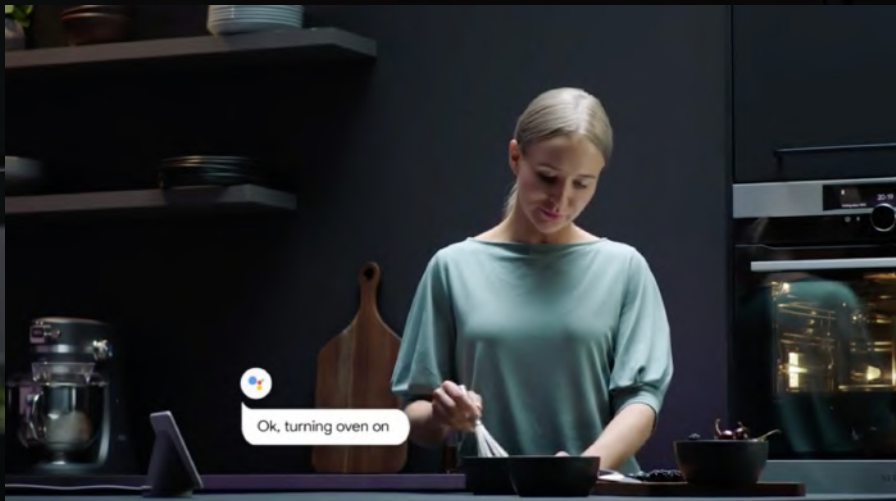

Ok, turning oven on

THE EXTENDED FAMILY



The CookView® Camera

Our WiFi connected oven features an internal CookView® camera located in the handle with a clear view into the oven cavity. It's wirelessly linked to the My AEG Kitchen App and allows you to watch a live feed of your food being cooked that you are able to see wherever you are.

Are you proud of what you are cooking? Then why not share the picture taken with the CookView® camera directly from your oven through social media and share with your family and friends.





CamCook

CamCook technology works in multiple ways. It operates either through the CookView® camera in our ovens or simply through the camera in your smartphone or tablet.

The technology recognises your favourite dishes, letting you achieve the same perfect result every time – for truly effortless cooking.

And for added ease, save your favourite dishes in the preferred cooking settings, for reliable results.

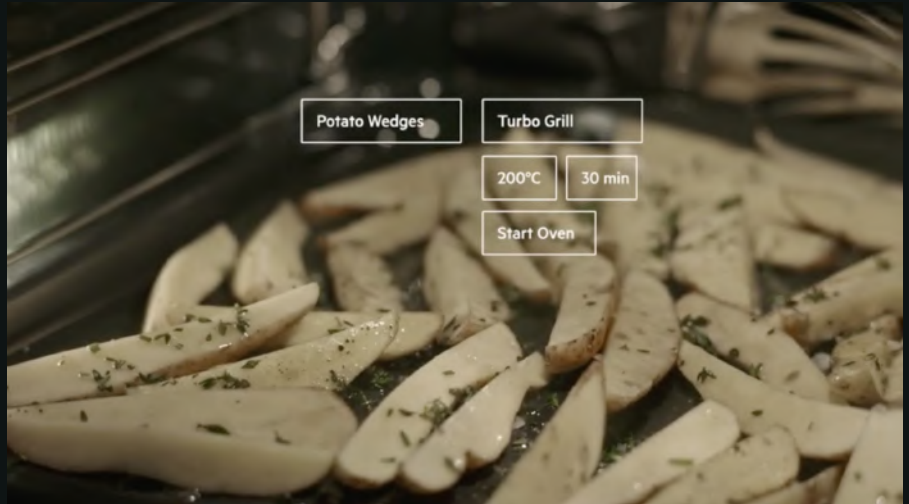

Steamify®

The Steamify® function handles all the steam settings so that you can cook exactly as you normally would.

Simply enter the cooking temperature and the oven automates everything related to the steam, enabling you to enjoy the healthy and flavourfull taste of steam cooking. Access Steamify® through the My AEG Kitchen App.



FOR MAXIMUM FLAVOUR, ADD STEAM

Our range of ovens with steam is one of the best ways to take taste further. It dispenses just the right amount of steam to lock taste and moisture into the food and make vitamins and nutrition stay. It also preserves textures and fibers, giving you more vibrant greens, more tender meat and make leftover bread as good as fresh again.

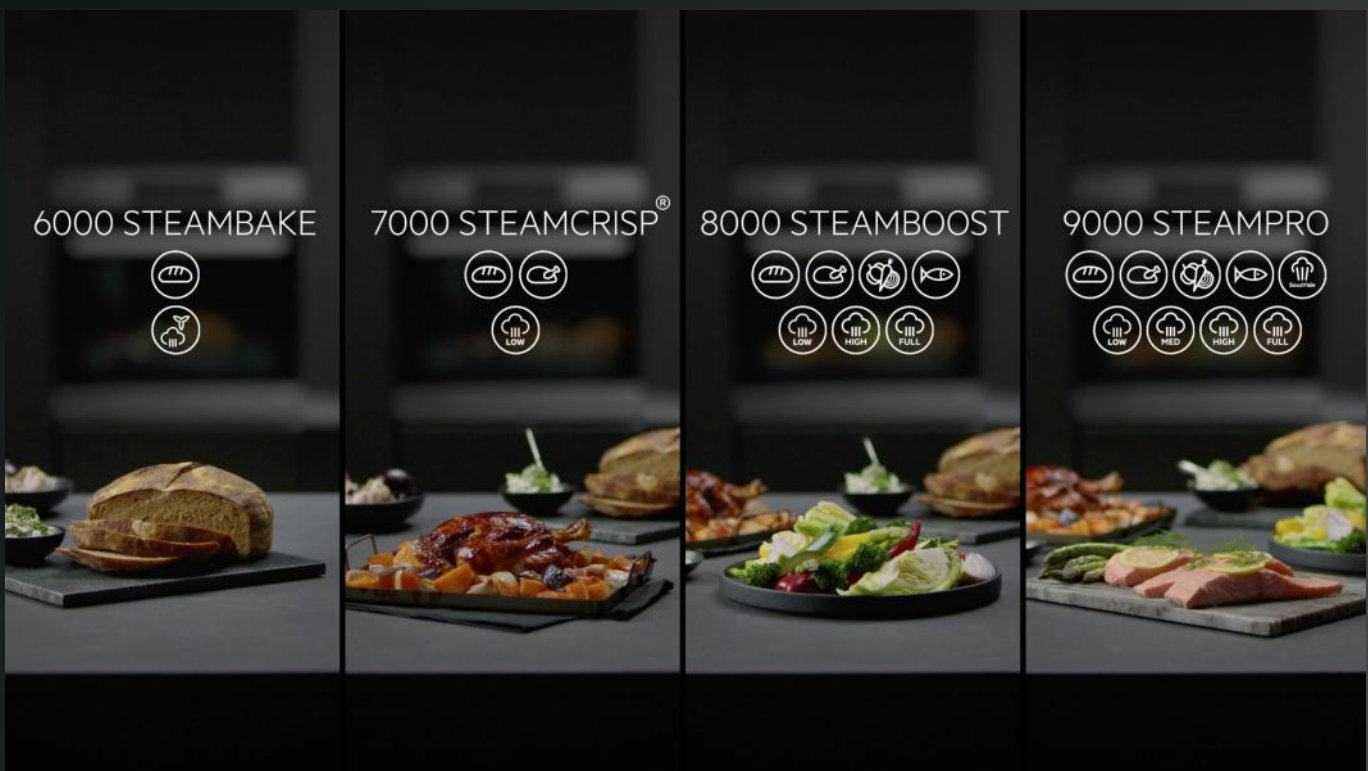

WHY STEAM?

Food stays moist. Prevents food from drying out.

Preservation. Preserves nutrients, vitamins and minerals.

Evenly cooked. Cooks food more evenly from surface to core.

More efficient. Delivers heat more efficiently to the food than dry, hot air, so the temperature can be lower.

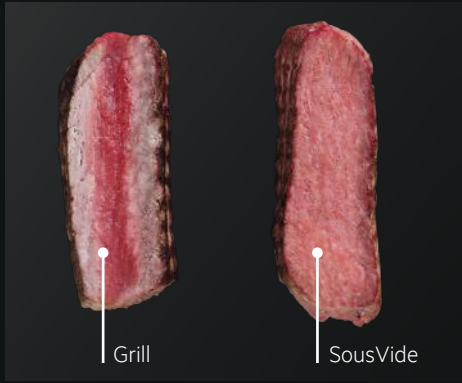

SteamPro

SteamPro with SousVide means you can create tastier and healthier dishes. Cook with absolute purity, sealing in all the aromas, taste and nutrients under vacuum, then applying gentle steam heat to cook delicious dishes.



SteamBoost

Turn flavour up to full, whether you are baking, roasting, poaching or steaming with SteamBoost. The right amount of steam locks in the natural moisture to deliver juicy and succulent dishes.



SteamCrisp

By combining steam and traditional heat, food is cooked gently from the outside to the centre, enhancing food taste and achieving better results. Perfect for all your favourite roasting and baking recipes.



SteamBake™

Adds a bit of steam for the right colour and crust, improving all of your baking results.

COOKING ICONS

KEY FEATURES GUIDE



SteamPro

Our SteamPro multifunctional ovens provide you with the SousVide function, a powerful tool that has been used by professional chefs for many years. They also include all of the benefits of our SteamBoost and SteamCrisp models.



SteamBoost

The introduction of steam makes all the difference. Locking in the natural moisture to deliver a whole range of juicy and succulent dishes including meat, fish, casseroles and vegetables – even desserts. Our SteamBoost models have 3 levels of steam (humidity), low, medium and high.



SteamCrisp

By combining steam (to produce low humidity) and traditional heat in the Quarter steam programme, food is cooked gently from the outside to the centre, enhancing food taste and achieving better results. Perfect for cooking the Sunday roast.



SteamBake™

Adds a bit of steam for the right colour and crust, improving all of your baking results.



Steamify®

Mastering precise results with steam has never been easier. Select your desired cooking temperature and Steamify® will automatically add the optimal amount of steam.



Connected

Easily monitor and set your oven programmes with our AEG App. This allows you to adjust cooking programmes, follow step by step recipes, and even allows you to set cooking programmes based on real time food images.



SurroundCook®

Hot air fan that circulates the air more effectively than a conventional oven so that your food gets evenly cooked anywhere in the oven.



SenseCook

Food sensor that adapts to what you are cooking and helps you get the results you are aiming for. Just tell the oven how you want your dish cooked and the oven will let you know once your food has reached the right temperature.



Multifunction

Multifunction ovens have all of the familiar cooking functions, including our extra large hot air fan.



Dual Multifunction

Both oven cavities are multifunctional, which means they have all of the traditional cooking functions including True Fan.



Command Wheel

The Command Wheel gives you an intuitive way to operate all the cooking settings. It swiftly responds to your actions so that you always have control of every step of the cooking process.



ProSight / EXCite Touch Controls

Full-touch electronic control panel – simple to operate and beautifully designed.



Retractable Controls

High quality finish stainless steel retractable knobs.



800w Quartz Grill

Flexible cooking thanks to microwave functions and integrated quartz grill.



CookView

With the CookView camera and connection to the AEG app you can start to visually control and finetune the cooking progress straight from the app.



Pyrolytic

With our Pyrolysis function, this self cleaning oven heats up to 500°C and turns food residue to ash.



Catalytic Liners

The catalytic lining absorbs the grease from cooking and is activated by regular heating to 220°C. The grease residue is oxidised leaving the catalytic surface clean.



XXL

All of our single ovens have an extra large capacity, allowing you to cook on all 5 levels simultaneously.



Telescopic Runners

Allows you to pull the shelves smoothly out of the oven. This enables you to efficiently and safely access the contents of your oven



Fully Programmable

Precise timer that switches off the oven when you want. Ideal for dishes with a long cooking process.



3 Vacuum Settings

Seal your food under a range of air extraction levels, from 50% – 99% efficiency, ensuring that marinades don't leak from the bag and that no unnecessary air enters it.



Non-Vented Installation

Self ventilating microwaves, allows for more flexibility when installing.

FUNCTIONS



SousVide Cooking

SousVide cooking is an old cooking technology used by professional chefs to cook vacuum packed food slowly at a low, accurately controlled temperature.



Full Steam

The SteamBoost oven with Full Steam function makes more of the flavours within your food. Combining all of traditional oven functions with the added benefit of steam.



Humidity High

The function is suitable for cooking delicate dishes like custards, flans, terrines and fish.



Humidity Medium

The function is suitable for cooking stewed and braised meat as well as bread and sweet yeast dough. Due to the combination of steam and heat the meat gets a juicy and tender texture and yeast dough bakes get a crispy and shiny surface.



Humidity Low

The function is suitable for meat, poultry, oven dishes and casseroles. Thanks to the combination of 25% steam and 75% heat, meat gets a tender and juicy texture along with a crusty surface.



True Fan Cooking

Our true fan cooking system gently circulates hot air through the oven cavity. As the oven heats up faster, lower temperatures and shorter cooking times are used to achieve delicious results.



Conventional Cooking

Top and bottom elements heat the oven, providing traditional cooking on one shelf position, which is ideal for baking breads or fruitcakes.



Au Gratin

For dishes such as lasagne or potato gratin.



Bottom Heat

Oven is heated by the bottom element only. Food is gently reheated, ideal for pies and pastries, as it keeps the pastry crisp.



Turbo Grilling

Heat from the top element is circulated by the fan, sealing and crisping the food.



Grilling

Fully controllable powerful grill, ideal for family-sized portions of food.



Steam Assisted Fan Cooking

An improved version of the traditional True Fan cooking, combining steam with an extra large hot air fan.



Pizza Setting

Designed to ensure pastry bases, quiches and pizzas are cooked to your taste.



Moist Fan Baking

Retains moisture within the ovens, thus achieving light fluffy results whilst using the oven in an energy efficient way.



Slow Cooking

Two slow cook options, dependent on the quantity of food being cooked. Low temperature combined with patience will guarantee a good result.



Defrost

Defrost your frozen food gently in half the usual time. Ambient air is quickly circulated inside the oven cavity.



Fast Grilling

Combining grill, fan and bottom heat to efficiently produce delicious dishes. Excellent on semi-processed food such as chips and spring rolls.



Bread Baking

Optimum temperature and environment for baking yeast mixtures. Using radiant heat and steam to bake a variety of loaves to your taste.



Dough Proving

Creates the perfect environment to assist bread baking by proving your yeast mixture correctly.



Eco Roasting

Economical setting for roasting large joints or poultry. Simply select the appropriate cooking time depending on the weight of the food, and the oven automatically switches off once the cooking is complete.



Pyrolysis

A total self-cleaning function that heats up to 500°C and turns food residue to ash.



Quarter Steam & Heat

25% steam and 75% heat locks in moisture and browns the outside for irresistible flavours.



Microwave & Grill

Combines traditional microwave and grill functions.



Microwave & Oven

Combines traditional microwave and oven functions.



Defrost by Weight

Take the guesswork away and defrost your food by weighing it during the process.



Auto Favourite

The Auto favourite function has 3 pre-set functions, these are Soften Butter, Melt Chocolate and Mug Cake. You can overwrite these with your favourite recipes.



Steam Regeneration

A great alternative to using the microwave, this function gently reheats previously cooked food using steam, without compromising on flavour or texture.

SINGLE OVENS

STEAM MULTIFUNCTION OVENS



Connected Matt Black SteamPro Oven
with Command Wheel

BSK993330T

KEY FEATURES



Connected



SteamPro



Command
Wheel



CookView



Steamify®



SenseCook



Connected SteamPro Oven
with Command Wheel

BSK999330M

KEY FEATURES



Connected



SteamPro



Command
Wheel



SenseCook



Steamify®



CookView

OVEN FUNCTIONS



SousVide Cooking



Bottom Heat



Full Steam



Pizza Setting



Humidity High



Moist Fan Baking



Humidity Medium



Slow Cooking



Humidity Low



Defrost



True Fan Cooking



Au Gratin



Conventional Cooking



Bread Baking



Turbo Grilling



Dough Proving



Grilling



Steam Regeneration

OVEN FUNCTIONS



SousVide Cooking



Bottom Heat



Full Steam



Pizza Setting



Humidity High



Moist Fan Baking



Humidity Medium



Slow Cooking



Humidity Low



Defrost



True Fan Cooking



Au Gratin



Conventional Cooking



Bread Baking



Turbo Grilling



Dough Proving



Grilling



Steam Regeneration

Model Features

Steam cleaning

Quadruple door glazing

Enamel liners

Telescopic runners

Fully programmable timer

XXL baking tray

TFT display

Steam set

70 ltr oven capacity

Humidity sensor

Fast heat up

30°C – 230°C

Surround cook

Model Features

Steam cleaning

Quadruple door glazing

Enamel liners

Telescopic runners

Fully programmable timer

XXL baking tray

TFT display

Steam set

70 ltr oven capacity

Humidity sensor

Fast heat up

30°C – 230°C

Surround cook

Energy Rating: A++

**Appliance/Built-in Dimensions
(HxWxD) in mm:**

594 x 595 x 567 / 590 x 560 x 550

Energy Rating: A++

**Appliance/Built-in Dimensions
(HxWxD) in mm:**

594 x 595 x 567 / 590 x 560 x 550



SteamPro Oven
with EXCite Touch Controls
BSK798380M / BSK792380B

KEY FEATURES



SteamPro



EXCite Touch Controls



Steamify®



SenseCook



SurroundCook®



SteamBoost Oven
with ProSight Touch Controls
BSK782320M

KEY FEATURES



SteamBoost



ProSight Touch Controls



SenseCook







SurroundCook®



Soft Close

OVEN FUNCTIONS

 SousVide Cooking	 Bottom Heat
 Full Steam	 Pizza Setting
 Humidity High	 Moist Fan Baking
 Humidity Medium	 Slow Cooking
 Humidity Low	 Defrost
 True Fan Cooking	 Au Gratin
 Conventional Cooking	 Bread Baking
 Turbo Grilling	 Dough Proving
 Grilling	 Steam Regeneration











Model Features

Steam cleaning	Quadruple door glazing
Enamel liners	Telescopic runners
Fully programmable timer	XXL baking tray
White Touch Control Display	XXL meat/grill pan
70 ltr oven capacity	Steam set
Fast heat up	30°C – 230°C
Double halogen lighting	

Energy Rating: A++

Appliance/Built-in Dimensions
(HxWxD) in mm:
594 x 595 x 567 / 590 x 560 x 550

OVEN FUNCTIONS

 Full Steam	 Moist Fan Baking
 Humidity High	 Slow Cooking
 Humidity Low	 Defrost
 True Fan Cooking	 Bread Baking
 Conventional Cooking	 Dough Proving
 Turbo Grilling	 Steam Regeneration
 Grilling	
 Bottom Heat	
 Pizza Setting	

Model Features

Steam cleaning	Two shelves
Enamel liners	Quadruple door glazing
Fully programmable timer	2 pairs of telescopic runners
White Touch Control Display	XXL baking tray
70 ltr oven capacity	XXL meat/grill pan
Fast heat up	Steam set
Double halogen lighting	30°C – 230°C

Energy Rating: A+

Appliance/Built-in Dimensions
(HxWxD) in mm:
594 x 595 x 567 / 590 x 560 x 550

SINGLE OVENS

STEAM MULTIFUNCTION OVENS WITH PYROLYTIC SELF-CLEANING



Connected SteamCrisp Oven
with Command Wheel Control

BSK978330M

KEY FEATURES



Pyrolytic



Connected



SteamCrisp



Command
Wheel



SenseCook



SurroundCook®



SteamCrisp Oven
with ProSight Touch Controls

BSK774320M

KEY FEATURES



Pyrolytic



SteamCrisp



ProSight



SenseCook



SurroundCook®

OVEN FUNCTIONS

- | | |
|------------------------|------------------|
| Quarter Steam and Heat | Moist Fan Baking |
| Steam Regenerating | Slow Cooking |
| True Fan Cooking | Defrost |
| Conventional Cooking | Au Gratin |
| Turbo Grilling | Humidity Low |
| Grilling | Bread Baking |
| Bottom Heat | Dough Proving |
| Pizza Setting | Pyrolysis |

Model Features

- | | |
|--------------------------|--------------------|
| Fully programmable timer | Telescopic runners |
| TFT display | XXL baking tray |
| 71 ltr oven capacity | XXL meat/grill pan |
| Fast heat up | 30°C – 300°C |
| Quadruple door glazing | |
| Double halogen lighting | |

Energy Rating: A++

Appliance/Built-in Dimensions
(HxWxD) in mm:

594 x 595 x 567 / 590 x 560 x 550

OVEN FUNCTIONS

- | | |
|------------------------|--------------------|
| Quarter Steam and Heat | Defrost |
| True Fan Cooking | Bread Baking |
| Conventional Cooking | Dough Proving |
| Turbo Grilling | Au Gratin |
| Bottom Heat | Humidity Low |
| Grilling | Slow Cooking |
| Pizza Setting | Pyrolysis |
| Moist Fan Baking | Steam Regeneration |

Model Features

- | | |
|--------------------------|--------------------|
| Fully programmable timer | XXL baking tray |
| White LED display | XXL meat/grill pan |
| 71 ltr oven capacity | 30°C – 300°C |
| Fast heat up | Telescopic runners |
| Double halogen lighting | Touch Control |
| Quadruple door glazing | |

Energy Rating: A+

Appliance/Built-in Dimensions
(HxWxD) in mm:

594 x 595 x 567 / 590 x 560 x 550

PYROLYTIC SELF-CLEANING OVENS



Connected Matt Black Multifunction Oven

BPK948330T

KEY FEATURES



Pyrolytic



Connected



Multifunction

Command
Wheel

SenseCook



SurroundCook®

OVEN FUNCTIONS



True Fan Cooking



Conventional Cooking



Turbo Grilling



Grilling



Bottom Heat



Pizza Setting



Moist Fan Baking



Defrost



Slow Cooking



Dough Proving



Au Gratin



Bread Baking



Pyrolysis

Model Features

Fully programmable timer

TFT display

71 ltr oven capacity

Fast heat up

Double halogen lighting

Telescopic runners

Quadruple door glazing

XXL baking tray

XXL meat/grill pan

30°C – 300°C

Energy Rating: A++**Appliance/Built-in Dimensions
(HxWxD) in mm:**

594 x 595 x 567 / 590 x 560 x 550

Connected Multifunction Oven
with Command Wheel Control

BPK948330M

KEY FEATURES



Pyrolytic



Connected



Multifunction

Command
Wheel

SenseCook



SurroundCook®

OVEN FUNCTIONS



True Fan Cooking



Conventional Cooking



Turbo Grilling



Grilling



Bottom Heat



Pizza Setting



Moist Fan Baking



Slow Cooking



Defrost



Au Gratin



Bread Baking



Dough Proving



Pyrolysis

Model Features

Fully programmable timer

TFT display

71 ltr oven capacity

Fast heat up

Quadruple door glazing

Double halogen lighting

Telescopic runners

XXL meat/grill pan

30°C – 300°C

Energy Rating: A++**Appliance/Built-in Dimensions
(HxWxD) in mm:**

594 x 595 x 567 / 590 x 560 x 550

SINGLE OVENS

PYROLYTIC SELF-CLEANING OVENS



Multifunction Oven
with EXCite Touch Controls
BPK748380M / BPK748380B

KEY FEATURES



Pyrolytic



Multifunction



EXCite
Touch Controls



SenseCook



SurroundCook®



Soft Close

OVEN FUNCTIONS



True Fan Cooking



Defrost



Conventional Cooking



Slow Cooking



Turbo Grilling



Dough Proving



Grilling



Au Gratin



Bottom Heat



Bread Baking



Pizza Setting



Pyrolysis



Moist Fan Baking

Model Features

Fully programmable timer

XXL baking tray

White LED display

XXL meat/grill pan

71 ltr oven capacity

30°C – 300°C

Fast heat up

Telescopic runners

Double halogen lighting

Quadruple door glazing

Energy Rating: A++

**Appliance/Built-in Dimensions
(HxWxD) in mm:**

594 x 595 x 567 / 590 x 560 x 550



Multifunction Oven
with ProSight Touch Controls and Side Hinged Door
BPK744L21M

KEY FEATURES



Pyrolytic



Multifunction



ProSight
Touch Controls



Side Hinged



SenseCook



SurroundCook®

OVEN FUNCTIONS



True Fan Cooking



Defrost



Conventional Cooking



Slow Cooking



Turbo Grilling



Dough Proving



Grilling



Au Gratin



Bottom Heat



Bread Baking



Pizza Setting



Eco Roasting



Moist Fan Baking



Pyrolysis

Model Features

Fully programmable timer

XXL baking tray

White LED display

XXL meat/grill pan

71 ltr oven capacity

30°C – 300°C

Fast heat up

Telescopic runners

Double halogen lighting

Quadruple door glazing

Energy Rating: A+

**Appliance/Built-in Dimensions
(HxWxD) in mm:**

594 x 594 x 568 / 600 x 560 x 550

Also available: BPK744R21M – Right side hinges

PYROLYTIC SELF-CLEANING OVENS WITH STEAMBAKE™



Multifunction Oven
with Retractable Controls and Soft Close Door
BPK55632PM

KEY FEATURES



Pyrolytic



SteamBake™



Multifunction



Retractable
Controls



Soft Close



SenseCook

OVEN FUNCTIONS



True Fan Cooking



Defrost



Conventional Cooking



Pyrolysis



Turbo Grilling



Grilling



Bottom Heat



Pizza Setting



Moist Fan Baking

Model Features

Touch control fully programmable timer

White LED display

71 ltr oven capacity

Fast heat up

Single halogen lighting

Quadruple door glazing

XXL baking tray

XXL meat/grill pan

30°C – 300°C

Telescopic runners

Energy Rating: A+

**Appliance/Built-in Dimensions
(HxWxD) in mm:**

594 x 595 x 567 / 590 x 560 x 550



Multifunction Oven
with Retractable Controls
BPK355020M

KEY FEATURES



Pyrolytic



SteamBake™



Multifunction



Retractable
Controls



SurroundCook®

OVEN FUNCTIONS



True Fan Cooking



Defrost



Conventional Cooking



Pyrolysis



Turbo Grilling



Grilling



Bottom Heat



Pizza Setting



Moist Fan Baking

Model Features

Fully programmable timer

White LED display

71 ltr oven capacity

Single halogen lighting

Quadruple door glazing

XXL meat/grill pan

30°C – 300°C

Energy Rating: A+

**Appliance/Built-in Dimensions
(HxWxD) in mm:**

594 x 595 x 567 / 590 x 560 x 550

SINGLE OVEN

CATALYTIC CLEANING OVEN
WITH STEAMBAKE™



reddot winner 2021
Premier Partner
EXCLUSIVE

Multifunction Oven
with Retractable Controls

BCK55632XM

KEY FEATURES



Catalytic
Liners



SteamBake™



Multifunction



Retractable
Controls



SenseCook



SurroundCook®

OVEN FUNCTIONS



True Fan Cooking



Pizza Setting



Conventional Cooking



Moist Fan Baking



Turbo Grilling



Defrost



Grilling



Catalytic Liners



Bottom Heat

Model Features

Touch control fully programmable timer

White LED display

30°C – 300°C

71 ltr oven capacity

Telescopic runners

Single halogen lighting

Touch buttons on timer

Triple door glazing

XXL meat/grill pan

Energy Rating: A+

**Appliance/Built-in Dimensions
(HxWxD) in mm:**

594 x 595 x 567 / 590 x 560 x 550

AEG
REWARDS

Cooking Result
Rare
• Medium
Well Done

CLAIM UP TO
£500
CASHBACK

Claim up to £500 cashback when you buy
3 or more AEG appliances for your kitchen.

Your purchase needs to include an AEG oven and hob.

OFFER AVAILABLE 01.05.22 – 30.11.22

Terms and conditions apply.

Speak to your AEG Premier Partner Kitchen Studio for more information.

AEG

aeg.co.uk/rewards2022H2

DOUBLE OVENS

BUILT-IN

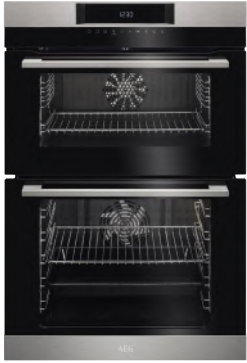

Dual Multifunction Oven with SurroundCook® and ProSight Touch Controls

DCK731110M

KEY FEATURES



Dual Multifunction



SurroundCook®



ProSight Touch Controls



Catalytic Liners

TOP OVEN FUNCTIONS



True Fan Cooking



Pizza Setting



Turbo Grilling



Slow Cooking



Grilling



Defrost



Bottom Heat

MAIN OVEN FUNCTIONS



Bottom Heat



Pizza Setting



Conventional Cooking



Slow Cooking



Defrost



True Fan Cooking



Grilling



Turbo Grilling

Model Features

Fully programmable timer
White LED display
39 ltr top oven capacity
61 ltr bottom oven capacity
Single oven lights
Triple door glazing

4/5 shelf positions
XXL baking tray
XXL meat/grill pan
Telescopic runners
30°C – 300°C

Energy Rating: A/A

Appliance/Built-in Dimensions (HxWxD) in mm:

888 x 594 x 568 / 875 x 560 x 550



Dual Multifunction Oven with SurroundCook® and Retractable Controls

DCK431110M

KEY FEATURES



Dual Multifunction



SurroundCook®



Retractable Controls



Catalytic Liners

TOP OVEN FUNCTIONS



Conventional Cooking



Bottom Heat



Fast Grilling



Grilling



Top heat

MAIN OVEN FUNCTIONS



Conventional Cooking



Grilling



True Fan Cooking



Defrost



Moist Fan Baking



Pizza Setting



Turbo Grilling



Bottom Heat

Model Features

Fully programmable timer
White LED display
43 ltr top oven capacity
68 ltr bottom oven capacity
Single oven lights
Double door glazing

4/5 shelf positions
XXL baking tray
XXL meat/grill pan
50°C – 275°C

Energy Rating: A/A

Appliance/Built-in Dimensions (HxWxD) in mm:

594 x 595 x 568 / 590 x 560 x 550

BUILT-UNDER



Dual Multifunction Oven with SurroundCook®
and ProSight Touch Controls

DUK731110M

KEY FEATURES



Dual
Multifunction



SurroundCook®



ProSight
Touch Controls



CATALYTIC
Liners

TOP OVEN FUNCTIONS



True Fan Cooking



Pizza Setting



Turbo Grilling



Slow Cooking



Grilling



Defrost



Bottom Heat

MAIN OVEN FUNCTIONS



Bottom Heat



Pizza Setting



Conventional Cooking



Slow Cooking



Defrost



True Fan Cooking



Grilling



Turbo Grilling

Model Features

Fully programmable timer

4/4 shelf positions

ProSight Touch Controls

XXL baking tray

39 ltr top oven capacity

XXL meat/grill pan

45 ltr bottom oven capacity

50°C – 275°C

Single oven lights

Triple door glazing

Energy Rating: A/A

**Appliance/Built-in Dimensions
(HxWxD) in mm:**

715 x 594 x 568 / 720 x 600 x 550

THE COMPACT RANGE THAT FITS INTO YOUR LIFESTYLE

With our widest range of high performance appliances, you can mix and match our ovens and compacts – the way you want – and it all aligns beautifully with a single, stylish design.

The Compact range also fits perfectly with our full size appliances.



Square Alignment Compacts

Create your ideal kitchen in a combination to suit your needs. By grouping your compact appliances in a cluster, a column or a sleek horizontal run you create your own, individual look.



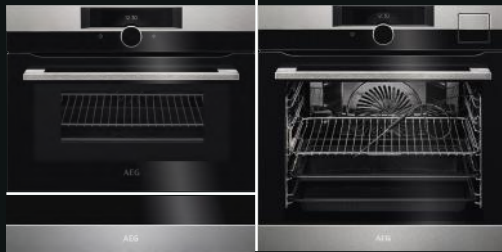

Horizontal Alignment Oven and Compacts

Compact Appliance, Warming Drawer or Vacuum Sealer and an AEG Single Oven.

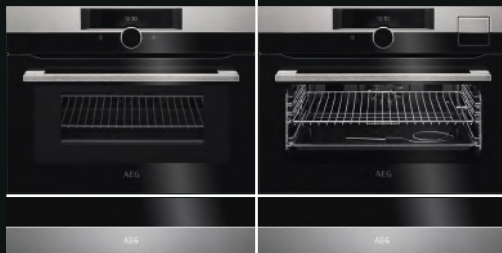

Horizontal Alignment Compacts

Two Compact Appliances with two Warming Drawers or Vacuum Sealers.



Vertical Alignment Oven and Compact

Compact above an AEG Single Oven.

THE PERFECT DESIGN ALIGNMENT

Our oven and compact range offer the perfect design alignment options, both horizontally and vertically.



For matching design alignment including user interface, pair appliances with the same controls using the below chart.

Product Description	Command Wheel Control	EXC ite Touch Controls	ProSight Touch Controls	Retractable Rotary Controls
Single Multifunction SteamBake™ Oven with Catalytic Cleaning				BCK55632XM
Single Multifunction Oven with Pyrolytic Self-Cleaning	BPK948330M	BPK748380M		BPK55632PM
Single Multifunction Oven with Pyrolytic Self-Cleaning and Side Hinged Door			BPK744L21M BPK744R21M	
Single Multifunction SteamCrisp Oven with Pyrolytic Self-Cleaning	BSK978830M		BSK774320M	
Single Multifunction SteamBoost Oven			BSK782320M	
Single Multifunction SteamPro Oven	BSK999330M	BSK798380M		
Compact Multifunction Oven with Microwave	KMK968000M	KMK768080M		KMK565000M
Compact Microwave with Grill				KMK525800M
Compact Coffee Machine	KKK994500M		KKK884500M	
14cm Warming Drawer	KDK911424M	KDK911424M	KDK911424M	KDK911424M

Command Wheel Controls



The Command Wheel gives you an intuitive way to operate all the cooking settings. It swiftly responds to your actions so that you always have control of every step of the cooking process.

EXCite Touch Controls



Intuitive touch display control panel gives you access to a wide variety of oven functions to suit every dish.

ProSight Touch Controls



LCD display with electronic touch control panel – simple to operate and beautifully designed.

Retractable Rotary Controls



High quality finish stainless steel retractable knobs.

COMPACTS

MULTIFUNCTION OVENS WITH MICROWAVE



Connected Matt Black Oven
with Command Wheel Control
KMK968000T

KEY FEATURES



Connected



Multifunction



Microwave

Command
Wheel

SurroundCook®

OVEN FUNCTIONS

- | | |
|----------------------|--------------------|
| True Fan Cooking | Microwave function |
| Conventional Cooking | Bread Baking |
| Turbo Grilling | Au Gratin |
| Grilling | Dough Proving |
| Bottom Heat | Eco roasting |
| Pizza Setting | Slow Cooking |
| Defrost | Microwave & Oven |
| Fast Grilling | |

Model Features

Fully programmable timer	XXL baking tray
White LED display	XXL meat/grill pan
43 ltr oven capacity	30°C – 230°C
Single halogen lighting	1000W microwave
Triple door glazing	Glass microwave base plate

Appliance Dimensions (HxWxD) in mm:

455 x 595 x 567

Built-in Dimensions (HxWxD) in mm:

450 x 560 x 550



Connected Multifunction Oven
with Command Wheel Control
KMK968000M

KEY FEATURES



Connected



Multifunction



Microwave

Command
Wheel

SurroundCook®

OVEN FUNCTIONS

- | | |
|----------------------|--------------------|
| True Fan Cooking | Au Gratin |
| Conventional Cooking | Bread Baking |
| Turbo Grilling | Microwave Function |
| Grilling | Microwave & Oven |
| Bottom Heat | |
| Pizza Setting | |
| Slow Cooking | |
| Defrost | |

Model Features

Fully programmable timer	XXL baking tray
TFT display	XXL meat/grill pan
43 ltr oven capacity	30°C – 230°C
Single halogen lighting	1000W microwave
Triple door glazing	Glass microwave base plate

Appliance Dimensions (HxWxD) in mm:

455 x 595 x 567

Built-in Dimensions (HxWxD) in mm:

450 x 560 x 550



Multifunction Oven
with EXCite Touch Controls
KMK768080M / KMK768080B

KEY FEATURES



Multifunction



Microwave



Command
Wheel



SurroundCook®

OVEN FUNCTIONS



True Fan Cooking



Bread Baking



Conventional Cooking



Au Gratin



Turbo Grilling



Dough Proving



Grilling



Slow Cooking



Bottom Heat



Microwave & Oven



Pizza Setting



Defrost



Microwave Function

Model Features

Fully programmable timer	XXL baking tray
White LED display	XXL meat/grill pan
43 ltr oven capacity	30°C – 230°C
Single halogen lighting	1000W microwave
Triple door glazing	Glass microwave base plate

Appliance Dimensions (HxWxD) in mm:

455 x 595 x 567

Built-in Dimensions (HxWxD) in mm:

450 x 560 x 550



Multifunction Oven
with Retractable Controls
KMK565000M

KEY FEATURES



Multifunction



Microwave



Retractable
Controls



SurroundCook®

Premier Partner
EXCLUSIVE

OVEN FUNCTIONS



True Fan Cooking



Microwave function



Conventional Cooking



Microwave & Oven



Turbo Grilling



Grilling



Bottom Heat



Pizza Setting



Defrost



Fast Grilling

Model Features

Fully programmable timer	XXL baking tray
White LED display	30°C – 230°C
43 ltr oven capacity	Touch buttons on timer
Single halogen lighting	1000W microwave
Quadruple door glazing	Glass microwave base plate

Appliance Dimensions (HxWxD) in mm:

455 x 595 x 567

Built-in Dimensions (HxWxD) in mm:

450 x 560 x 550

COMPACTS

MICROWAVE WITH GRILL



Microwave
with Retractable Controls

KMK525800M

KEY FEATURES



Microwave



Retractable
Controls

OVEN FUNCTIONS

 Microwave & Grill

 Grilling

Model Features

Fully programmable timer	30°C – 230°C
White LED display	1000W microwave
42 ltr oven capacity	Large glass turntable
Single halogen lighting	1200watt grill
Triple door glazing	

Appliance Dimensions
(HxWxD) in mm:

455 x 595 x 567

Built-in Dimensions
(HxWxD) in mm:

450 x 560 x 550



20:02

AEG

AEG

AEG

AEG



COMPACTS

COFFEE MACHINES



Matt Black Coffee Machine
with Command Wheel Control

KKK994500T

FEATURES



Command
Wheel



Authentic
Italian Coffee



Fully
Automatic



Uses Fresh
Coffee Beans

OVEN FUNCTIONS

Espresso	Tea Water
Cappuccino	Latte Macchiato
Cappuccino Plus	Long Coffee
Caffè Latte	Warm Milk
Caffè Macchiato	Ristretto
Espresso Lungo	Steamer
Espresso Macchiato	Jug Function
Flat White	Two Cups

Model Features

Coffee jug	Water softener
Thermal milk container	2.4 ltr water tank
Descaler	400 gr grinder capacity
Cleaning brush	Quadruple LED lighting
Coffee powder spoon	
Telescopic runners + soft closing	

**Appliance Dimensions
(HxWxD) in mm:**

455 x 595 x 361

**Built-in Dimensions
(HxWxD) in mm:**

450 x 560 x 550



Coffee Machine
with Command Wheel Control

KKK994500M

FEATURES



Command
Wheel



Authentic
Italian Coffee



Fully
Automatic



Uses Fresh
Coffee Beans

OVEN FUNCTIONS

Espresso	Tea Water
Cappuccino	Latte Macchiato
Cappuccino Plus	Long Coffee
Caffè Latte	Warm Milk
Caffè Macchiato	Ristretto
Espresso Lungo	Steamer
Espresso Macchiato	Jug Function
Flat White	Two Cups

Model Features

Coffee jug	Water softener
Thermal milk container	2.4 ltr water tank
Descaler	400 gr grinder capacity
Cleaning brush	Quadruple LED lighting
Coffee powder spoon	
Telescopic runners + soft closing	

**Appliance Dimensions
(HxWxD) in mm:**

455 x 595 x 361

**Built-in Dimensions
(HxWxD) in mm:**

450 x 560 x 550



Coffee Machine
with ProSight Touch Controls
KKK884500M

FEATURES



ProSight
Touch Controls



Authentic
Italian Coffee



Fully
Automatic



Uses Fresh
Coffee Beans

OVEN FUNCTIONS

- Espresso
- Cappuccino
- Tea Water
- Two Cups
- Jug Function
- Steamer

Model Features

- Coffee jug
- Milk container
- Descaler
- 1.8 ltr water tank
- 200 gr grinder capacity
- Dual LED lighting

**Appliance Dimensions
(HxWxD) in mm:**
455 x 595 x 361

**Built-in Dimensions
(HxWxD) in mm:**
450 x 560 x 550

COMPACTS

WARMING DRAWERS



29cm Black Glass & Stainless Steel

KDK912924M

KEY FEATURES



29cm



12 Place
Settings



30-80°C
Temp range

FUNCTIONS

Cups and Glass Warming (45°C)	Dough Proving (30°C)
Plate Warming (60°C)	Keep Warm (70°C)
Food Reheating (60°C – 80°C Max)	Defrosting (30°C Max)

Model Features

Variable temperature control	Rotary control knob
On/off LED	Heating element
Anti-slip mat	Fan air circulation

**Appliance Dimensions
(HxWxD) in mm:**

295 x 595 x 535

**Built-in Dimensions
(HxWxD) in mm:**

295 x 560 x 550



29cm Stainless Steel

KDE912924M

KEY FEATURES



29cm



12 Place
Settings



30-80°C
Temp range

FUNCTIONS

Cups and Glass Warming (45°C)	Dough Proving (30°C)
Plate Warming (60°C)	Keep Warm (70°C)
Food Reheating (60°C – 80°C Max)	Defrosting (30°C Max)

Model Features

Variable temperature control	Rotary control knob
On/off LED	Heating element
Anti-slip mat	Fan air circulation

**Appliance Dimensions
(HxWxD) in mm:**

295 x 595 x 535

**Built-in Dimensions
(HxWxD) in mm:**

295 x 560 x 550



14cm Matt Black

KDK911424T

KEY FEATURES



14cm



6 Place
Settings



30-80°C
Temp range

FUNCTIONS

Cups and Glass Warming (40°C)	Dough Proving (30°C)
Plate Warming (60°C)	Keep Warm (70°C)
Food Reheating (60°C – 80°C Max)	Defrosting (30°C Max)

Model Features

Variable temperature control	Rotary control knob
On/off LED	Heating element
Anti-slip mat	Fan air circulation

Appliance Dimensions (HxWxD) in mm:

140 x 595 x 535

Built-in Dimensions (HxWxD) in mm:

141 x 560 x 550

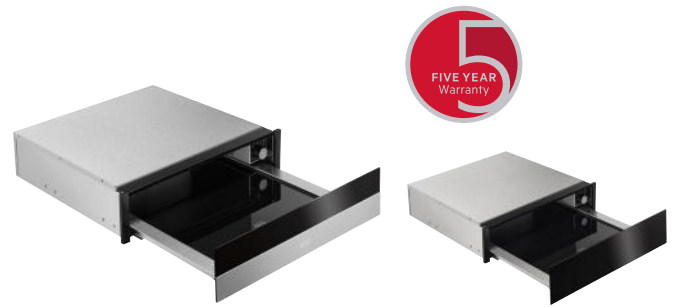

14cm Black Glass & Stainless Steel

KDK911424M / KDE911424B

KEY FEATURES



14cm



6 Place
Settings



30-80°C
Temp range

FUNCTIONS

Cups and Glass Warming (45°C)	Dough Proving (30°C)
Plate Warming (60°C)	Keep Warm (70°C)
Food Reheating (60°C – 80°C Max)	Defrosting (30°C Max)

Model Features

Variable temperature control	Rotary control knob
On/off LED	Heating element
Anti-slip mat	Fan air circulation

Appliance Dimensions (HxWxD) in mm:

140 x 595 x 535

Built-in Dimensions (HxWxD) in mm:

141 x 560 x 550

COMPACTS

WARMING DRAWERS

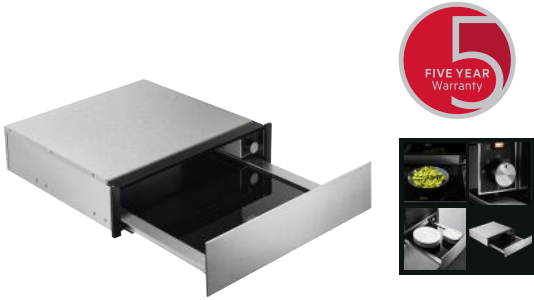

14cm Stainless Steel

KDE911424M

KEY FEATURES



14cm



6 Place
Settings



30-80°C
Temp range

FUNCTIONS

Cups and Glass Warming (45°C)	Dough Proving (30°C)
Plate Warming (60°C)	Keep Warm (70°C)
Food Reheating (60°C – 80°C Max)	Defrosting (30°C Max)

Model Features

Variable temperature control	Rotary control knob
On/off LED	Heating element
Anti-slip mat	Fan air circulation

Appliance Dimensions (HxWxD) in mm:

140 x 595 x 535

Built-in Dimensions (HxWxD) in mm:

141 x 560 x 550

VACUUM SEALERS



14cm Matt Black

KDK911423T

KEY FEATURES



14cm



Touch
Controls



White LEDs



3 Vacuum
Settings

FUNCTIONS

Marinating/Infusion	Min. Vacuum setting
Max. Vacuum setting	Sealing time displayed
Med. Vacuum setting	

Appliance Dimensions (HxWxD) in mm:

131 x 595 x 510

Built-in Dimensions (HxWxD) in mm:

139 x 560 x 550



14cm Black Glass & Stainless Steel/14cm Black Glass
KDK911423M / KDE911423B

KEY FEATURES

- 14 CM
14cm
- Touch Controls
- WHITE LED
White LEDs
- 3X VAC
3 Vacuum Settings

FUNCTIONS

Marinating/Infusion	Min. Vacuum setting
Max. Vacuum setting	Sealing time displayed
Med. Vacuum setting	

**Appliance Dimensions
(HxWxD) in mm:**
131 x 595 x 510

**Built-in Dimensions
(HxWxD) in mm:**
139 x 560 x 550

BUILT-IN MICROWAVE OVENS

AEG microwave ovens have an intuitive touchscreen control panel that features a simple wipeclean surface. The touch sensitive panel lets you change functions and timings in seconds too.



45cm High 26 Litre, with Touch Control

MBE2658SEM

KEY FEATURES



900w
Microwave



Touch
Control



Non-Vented
Installation

FUNCTIONS



Microwave



Child Lock



Defrost by Weight



Auto Favourite

Additional Features

26 ltr capacity

White LED display

32.5cm turntable

90min timer

LED lighting

Colour: Stainless Steel fascia panel

Appliance Dimensions

(HxWxD) in mm:

459 x 596 x 404

Built-in Dimensions

(HxWxD) in mm:

450 x 562 x 500



60cm Wide 17 Litre, with Touch Control

MBB1756SEM

KEY FEATURES



800w
Microwave



Touch
Control



Non-Vented
Installation

FUNCTIONS



Microwave



Child Lock



Defrost by Weight



Auto Favourite

Additional Features

17 ltr Capacity

White LED display

27cm turntable

90min timer

LED lighting

Colour: Stainless Steel fascia panel

Appliance Dimensions

(HxWxD) in mm:

371 x 594 x 316

Built-in Dimensions

(HxWxD) in mm:

360 x 562 x 300



50cm Wide 17 Litre, with Touch Control

MBB1755SEM

KEY FEATURES



800w
Microwave



Touch
Control



Non-Vented
Installation

FUNCTIONS



Microwave



Child Lock



Defrost by Weight



Auto Favourite

Additional Features

17 ltr Capacity

White LED display

27cm turntable

90min timer

LED lighting

Colour: Stainless Steel fascia panel

Appliance Dimensions

(HxWxD) in mm:

371 x 494 x 316

Built-in Dimensions

(HxWxD) in mm:

360 x 462 x 300

All AEG microwave ovens can be installed in all cabinetry, whether it be non-ventilated or ventilated kitchen cabinets, making them perfect for kitchen upgrades or replacements.

BLACKLINE RANGE



Multifunction SteamPro Oven
with EXCite Touch Controls

BSK792380B

KEY FEATURES



SteamPro



EXCite
Touch Controls



Steamify®



SenseCook



SurroundCook®



Multifunction Pyrolytic Self Cleaning Oven
with EXCite Touch Controls

BPK748380B

KEY FEATURES



Multifunction



Pyrolytic



EXCite
Touch Controls



SenseCook



SurroundCook®

OVEN FUNCTIONS

- SousVide Cooking
- Full Steam
- Humidity High
- Humidity Medium
- Humidity Low
- True Fan Cooking
- Conventional Cooking
- Turbo Grilling
- Grilling
- Bottom Heat
- Pizza Setting
- Moist Fan Baking
- Slow Cooking
- Defrost
- Au Gratin
- Bread Baking
- Dough Proving

Model Features

- Steam cleaning
- Enamel liners
- Fully programmable timer
- White Touch Control Display
- 70 ltr oven capacity
- Fast heat up
- Double halogen lighting
- Quadruple door glazing
- Telescopic runners
- XXL meat/grill pan
- Steam set
- 30°C – 230°C

Energy Rating: A++

Appliance/Built-in Dimensions
(HxWxD) in mm:

594 x 595 x 567 / 590 x 560 x 550

OVEN FUNCTIONS

- True Fan Cooking
- Conventional Cooking
- Turbo Grilling
- Grilling
- Bottom Heat
- Pizza Setting
- Moist Fan Baking
- Defrost
- Slow Cooking
- Dough Proving
- Au Gratin
- Bread Baking
- Pyrolysis

Model Features

- Fully programmable timer
- White LED display
- 71 ltr oven capacity
- Fast heat up
- Double halogen lighting
- Quadruple door glazing
- XXL meat/grill pan
- 30°C – 300°C
- Telescopic runners

Energy Rating: A++

Appliance/Built-in Dimensions
(HxWxD) in mm:

594 x 595 x 567 / 590 x 560 x 550



Multifunction Compact Oven
with Microwave

KMK768080B

KEY FEATURES



Multifunction



Microwave



EXCite
Touch Controls



SurroundCook®

OVEN FUNCTIONS

-  True Fan Cooking
-  Conventional Cooking
-  Turbo Grilling
-  Grilling
-  Bottom Heat
-  Pizza Setting
-  Defrost
-  Microwave function
-  Bread Baking
-  Au Gratin
-  Dough Proving
-  Dough Proving
-  Slow Cooking
-  Microwave & Oven

Model Features

- Fully programmable timer
- White LED display
- 43 ltr oven capacity
- Single halogen lighting
- Triple door glazing
- XXL meat/grill pan
- 30°C – 230°C
- 1000W microwave
- Glass microwave base plate

Energy Rating: -

**Appliance/Built-in Dimensions
(HxWxD) in mm:**

455 x 595 x 567 / 450 x 560 x 550



BLACKLINE RANGE



14cm Warming Drawer

KDE911424B

KEY FEATURES

- 
 14cm
- 
 6 Place Settings
- 
 30–80°C Temp Range

OVEN FUNCTIONS

Cups and Glass Warming (40°C)	Food Warming (80°C Max)
Plate Warming (60°C)	Defrosting (30°C Max)

Model Features

- Variable temperature control
- Rotary control knob
- On/off LED
- Heating element
- Anti-slip mat
- Fan air circulation

Appliance Dimensions (HxWxD) in mm:

131 x 595 x 500

Built-in Dimensions (HxWxD) in mm:



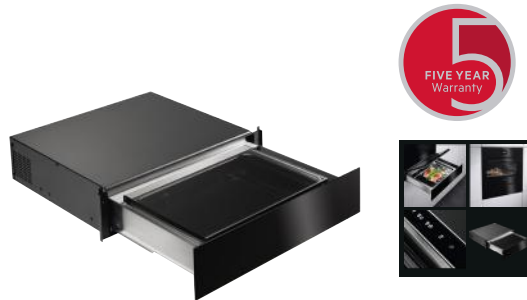

139 x 560 x 550



14cm Vacuum Sealer

KDE911423B

KEY FEATURES

- 
 14cm
- 
 ProSight Touch Controls
- 
 White LEDs
- 
 3 Vacuum Settings
- 
 SurroundCook®

OVEN FUNCTIONS

Marinating/Infusion	Min. Vacuum Setting
Max. Vacuum Setting	Sealing Time Displayed
Med. Vacuum Setting	

Appliance Dimensions (HxWxD) in mm:

131 x 595 x 500

Built-in Dimensions (HxWxD) in mm:

139 x 560 x 550

AEG



WHY LIMIT YOUR EXPECTATIONS?

At AEG we design our appliances to meet the diverse needs of the most ambitious chefs. Why limit your roasting to Sundays? What about a crisp, turnip salad on meat-free Monday, or succulent, sustainable haddock on fishy Friday? With AEG technology you can be adventurous and sustainable, with absolutely no compromise to taste.

CHALLENGE THE EXPECTED

HOBS

At AEG we believe that a hob should look as good as it performs. Which is why all our induction hobs are designed not just to bring out the best in your cooking, but also to give you the flexibility you need while cooking and to look fantastic in your kitchen.

IN THIS SECTION

Induction Hobs

Ceramic Hob

Gas Hobs

Mixed Fuel Hob

Modular Hob

eXTractor Hobs



SENSEPRO®



MAXISENSE®



SLIM INSTALLATION

TAKE THE GUESSWORK OUT OF COOKING

Why guess when you can be precise about each degree with the SensePro® hob. The wireless food sensor measures inner temperature and communicates heat adjustments to the hob. So you can achieve perfect core results.



SensePro®

The most advanced induction hob with sensor technology, equipped with a wireless food probe that enables precision cooking.





TotalFlex

The TotalFlex hob automatically detects pots and pans of various shapes and sizes, and creates a dedicated cooking zone for them. Offering you the freedom to move cookware almost anywhere on the glass surface.



Hob2Hood

The AEG Hob2Hood adapts to your cooking to keep your kitchen free of steam and vapours automatically.



Slim Installation

The slim, space-saving design embeds into worktops as shallow as 12mm, even with a drawer below.

HOB ICONS

KEY FEATURES GUIDE



ActiveTouch

The user interface is not visible until a pan is placed on the hob. The user interface contains DirekTouch for instant heat control with one touch, minute minder and auto bridge.



SenseFry®

Use the intelligent touchscreen on the SenseFry® induction hob to select the food and desired result. Rare, medium or well-done.



Touch Control

Efficient touch controls enable you to set the hob's heat level precisely, while its flat surface is easy to clean.



TFT Touch Display

A single, full colour touchscreen provides complete control over the hob. Monitor live feedback for each zone and adjust the settings accordingly.



DirekTouch Slider

This hob's direct-access heat controls enable you to switch directly to exactly the right temperature with one touch. Simply touch the correct level on the slide control.



SenseBoil™

A sensor actively monitors the progress of boiling water and automatically reduces to a simmer once boiled, keeping it ready for you to add your ingredients.



SensePro®

The most advanced induction hob with sensor technology, equipped with a wireless food probe that enables precision cooking.



MaxiSense®

The MaxiSense® induction hob has self-sizing cooking zones. Each zone detects the size and shape of the pan you're using, however large or small.



Single Bridge

Two zones can be paired at the touch of a button, providing a single bridge for cooking. By automatically aligning to share both temperature and time settings, it's optimised for using large pots and pans at once.



FlexiBridge

A multi-purpose zone that allows you to customize your own cooking area, combining up to 4 segments with a consistent and even heat distribution.



Double bridge

Two zones can be paired at the touch of a button, providing a single bridge for cooking. It's optimised for using large pots and pans by automatically aligning to share both temperature and time settings.



TotalFlex

The TotalFlex hob automatically detects pots and pans of various shapes and sizes, and creates a dedicated cooking zone for them. Offering you the freedom to move cookware almost anywhere on the glass surface.



Hob2Hood

Hob2Hood automatically turns on your cooker hood and lights when you start using the hob. The cooker hood will adjust according to the cooking levels on the induction zones.



Pure Black Design

Unique hob with pure black design. The hob controls and cooking zones are visible only when needed. When not in use, the surface is clean black, nothing to disturb the kitchen design.



Cast Iron Supports

Cast iron pan supports provide a robust and durable cooking support with professional design. Safe, long lasting and easy to clean.



Extendable Zone

Extendable zone, optimised for cooking with a wide range of pot sizes.



Slim Installation

AEG induction hobs have the slimmest platform on the market, allowing a worktop as thin as 28mm with an oven beneath the hob.



Easy Installation

Our Optifix™ spring system is self-installing and self-centering. Simply place the hob into your cut out.

KEY FEATURES GUIDE



Step Power Controls

The flame can be precisely set in 9 different levels to deliver reliable and consistent heat, every time. For cooking without guesswork.



Easy Clean

Because the surface around the pans stays cool as you cook, you can get rid of spills as you go along. Nothing gets burnt on and there's nowhere for dirt to hide.



Minute Minder

Perfect cooking results guaranteed by setting the cooking time length and the acoustic signal lets you know it has finished.



Auto Ignition

Total control of the ignition through a single-handed operation of turning the knob to automatically light the hob.



PowerSlide

From boiling to simmering to keeping warm. When you need repeated quick heat changes to create a dish, simply slide your pan from heat to heat.



Rotary

Classic rotary control knobs.

FUNCTIONS



Cook Assist

An innovative assisted cooking function. Select the dish and the desired result – rare, medium, well-done – to ensure consistent frying.



Count-Up Timer

Set a reminder or use the count-up timer to keep in control of your cooking.



Minute Minder

Each induction cooking zone has an independent 99 minute timer. The timer will switch the zone off after the time has elapsed.



Eco Timer

Energy saving timer that switches off the zone and uses residual heat to complete the last few minutes of cooking.



Zone Booster

Power booster function to reach high temperatures extra fast.



AutoMax

The hob will apply full output of heat at the beginning, before automatically dropping to the required setting.



SousVide Cooking

Cook to perfection with SousVide, a professional approach to cooking. Applies low temperature and stable temperature to vacuum packed food.



Pan Detection

The user interface is not visible until a pan is placed on the hob.



Auto Off

Safety mechanism that turns off the hob after a given time, depending on the selected heat setting.



Melting

A gentle melting function, perfect for chocolate or butter.



Burners

Number of burners.



Wok burner

Extra large burner designed for a large wok.



Stop & Go

A function that reduces all zones in operation to a 'keep warm' setting.



TripleZone

Triple extendable zone, optimized for cooking with a wide range of pot sizes.



Pause

A function that reduces all zones in operation to a 'keep warm' setting. Available with our new models.

HOBS

INDUCTION HOBS

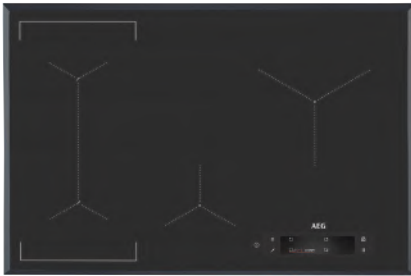

80cm SensePro®
with TFT Touch Control Display and FlexiBridge
IAE84881FB

KEY FEATURES

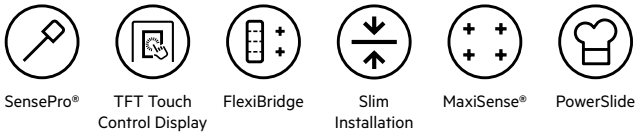

FUNCTIONS

Cook Assist	Stop & Go
Count Up Timer	Auto Off
Minute Minder	Melting
Eco Timer	SenseFry® assistance
Zone Booster	SousVide

Additional Features

Residual heat indicators	Electricity loading 7350W
Child lock	Food probe
Red LEDs	
Bevelled 4 sides	

Energy Rating: N/A

Appliance Dimensions (HxWxD) in mm:
44 x 780 x 520

Built-in Dimensions (HxW) in mm:
750 x 490



80cm TotalFlex
with ActiveTouch, 6 Cooking Zones and Hob2Hood
IKK86681FB

KEY FEATURES



FUNCTIONS

Pan Detection	Stop & Go
Count Up Timer	
Minute Minder	
Eco Timer	
Zone Booster	

Additional Features

Residual heat indicators	Red and White LEDs
Child lock	Bevelled 4 sides
Sound off	Electricity loading 7350W
Acoustic Signal	

Energy Rating: N/A







Appliance Dimensions (HxWxD) in mm:
44 x 780 x 520

Built-in Dimensions (HxW) in mm:
750 x 490







80cm SenseFry®
with TFT Touch Control Display and FlexiBridge
IAE84851FB

KEY FEATURES

- 
SenseFry®
- 
TFT Touch Control Display
- 
FlexiBridge
- 
Slim Installation
- 
MaxiSense®
- 
PowerSlide

FUNCTIONS

-  Cook Assist
-  Count Up Timer
-  Minute Minder
-  Eco Timer
-  Zone Booster
-  Stop & Go
-  Auto Off
-  Melting
-  Hob2Hood

Additional Features

- Residual heat indicators
- Electricity loading 7350W
- Child lock
- Red LEDs
- Bevelled 4 sides

Energy Rating: N/A





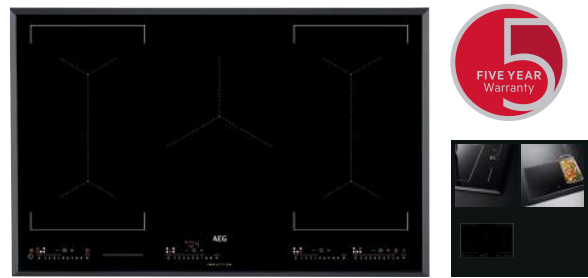

Appliance Dimensions (HxWxD) in mm:
44 x 780 x 520

Built-in Dimensions (HxW) in mm:
750 x 490









80cm 5 Zone MaxiSense®
with ActiveTouch and Double Bridge Zone
IKE85651FB

KEY FEATURES

- 
5 Cooking Zones
- 
MaxiSense®
- 
ActiveTouch
- 
Double Bridge
- 
Slim Installation
- 
Hob2Hood

FUNCTIONS

-  Pan Detection
-  Count Up Timer
-  Minute Minder
-  Eco Timer
-  Zone Booster
-  Stop & Go
-  Auto Off

Additional Features

- Residual heat indicators
- Electricity loading 7350W
- Child lock
- Red and White LEDs
- Bevelled 4 sides

Energy Rating: N/A

Appliance Dimensions (HxWxD) in mm:
44 x 810 x 520

Built-in Dimensions (HxW) in mm:
780 x 490

HOBS

INDUCTION HOBS

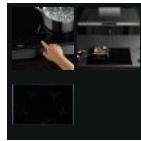

80cm PURE
with DirekTouch

IPE84531FB

KEY FEATURES



Pure Black Design



DirekTouch Slider



MaxiSense®



Hob2Hood



Slim Installation

FUNCTIONS

AutoMax

Eco Timer

Pan Detection

Zone Booster

Count Up Timer

Stop & Go

Minute Minder

Auto Off

Additional Features

Residual heat indicators

Bevelled 4 sides

Child lock

Electricity loading 7350W

Red LEDs

Energy Rating: N/A

Appliance Dimensions (HxWxD) in mm:

44 x 780 x 520

Built-in Dimensions (HxW) in mm:

750 x 490

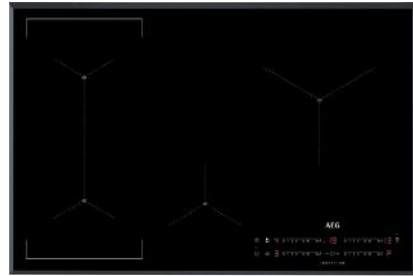

80cm SenseBoil®
with DirekTouch and Single Bridge Zone

IAE84421FB

KEY FEATURES



SenseBoil™



DirekTouch Slider



Single Bridge



Slim Installation



Hob2Hood



MaxiSense®

FUNCTIONS

AutoMax

Zone Booster

Count Up Timer

Stop & Go

Minute Minder

Auto Off

Eco Timer

Additional Features

Residual heat indicators

Bevelled 4 sides

Child lock

Electricity loading 7350W

Red LEDs

Energy Rating: N/A

Appliance Dimensions (HxWxD) in mm:

44 x 780 x 520

Built-in Dimensions (HxW) in mm:

750 x 490



80cm 5 Zone MaxiSense®
with DirekTouch

IKE85751FB

KEY FEATURES

- 5 Cooking Zones
- MaxiSense®
- DirekTouch Slider
- Slim Installation
- Hob2Hood
- Double Bridge

FUNCTIONS

- AutoMax
- Zone Booster
- Count Up Timer
- Pause
- Minute Minder
- Auto Off
- Eco Timer

Additional Features

- Residual heat indicators
- Bevelled 4 sides
- Child lock
- Electricity loading 7350W
- Red LEDs
- Pan detection

Energy Rating: N/A

Appliance Dimensions (HxWxD) in mm:
44 x 780 x 520

Built-in Dimensions (HxW) in mm:
750 x 490



80cm SenseBoil®
with DirekTouch

IAE84411FB

KEY FEATURES

- SenseBoil™
- DirekTouch Slider
- Slim Installation
- Hob2Hood
- MaxiSense®

FUNCTIONS

- AutoMax
- Zone Booster
- Count Up Timer
- Stop & Go
- Minute Minder
- Auto Off
- Eco Timer

Additional Features

- Residual heat indicators
- Bevelled 4 sides
- Child lock
- Electricity loading 7350W
- Red and White LEDs

Energy Rating: N/A

Appliance Dimensions (HxWxD) in mm:
44 x 810 x 520

Built-in Dimensions (HxW) in mm:
750 x 490

HOBS

INDUCTION HOBS



80cm MaxiSense®
with DirekTouch

IKB84401FB

KEY FEATURES



MaxiSense®



DirekTouch
Slider



Slim
Installation



Hob2Hood

FUNCTIONS

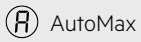

AutoMax



Zone Booster



Count Up Timer



Stop & Go



Minute Minder



Auto Off



Eco Timer

Additional Features

Residual heat indicators

Bevelled 4 sides

Child lock

Electricity loading 7350W

Red LEDs

Energy Rating: N/A

**Appliance Dimensions
(HxWxD) in mm:**

44 x 910 x 410

**Built-in Dimensions
(HxW) in mm:**

750 x 490

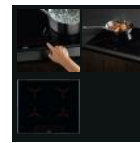
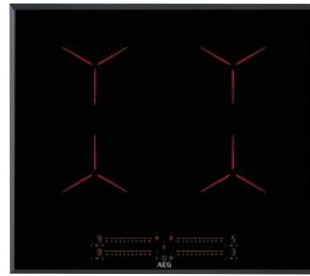

60cm PURE with
DirekTouch and Double Bridge Zone

IPE64551FB

KEY FEATURES



Pure Black
Design



DirekTouch
Slider



Double
Bridge



MaxiSense®



Hob2Hood



Slim
Installation

FUNCTIONS

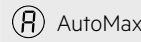

AutoMax



Zone Booster



Count Up Timer



Stop & Go



Minute Minder



Auto Off



Eco Timer

Additional Features

Residual heat indicators

Bevelled 4 sides

Child lock

Electricity loading 7350W

Red LEDs

Energy Rating: N/A

**Appliance Dimensions
(HxWxD) in mm:**

44 x 590 x 520

**Built-in Dimensions
(HxW) in mm:**

560 x 490

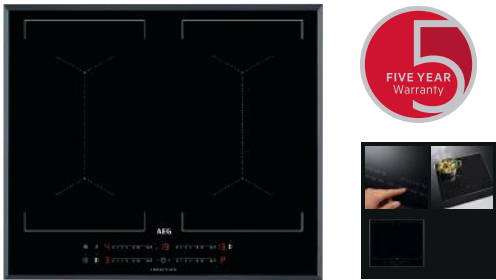

60cm MaxiSense®
with DirekTouch and Double Bridge Zone

IKE64450FB

KEY FEATURES

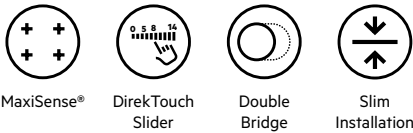

FUNCTIONS

AutoMax	Zone Booster
Count Up Timer	Stop & Go
Minute Minder	Auto Off
Eco Timer	

Additional Features

Residual heat indicators	Bevelled edge
Child lock	Electricity loading 7350W
Red LEDs	

Energy Rating: N/A

Appliance Dimensions (HxWxD) in mm:	Built-in Dimensions (HxW) in mm:
46 x 590 x 520	560 x 490



60cm SenseBoil™
with DirekTouch and Single Bridge Zone

IAE64421FB

KEY FEATURES

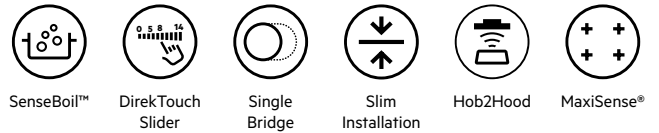

FUNCTIONS

AutoMax	Zone Booster
Count Up Timer	Stop & Go
Minute Minder	Auto Off
Eco Timer	

Additional Features

Residual heat indicators	Steel frame
Child lock	Electricity loading 7350W
Red and White LEDs	

Energy Rating: N/A

Appliance Dimensions (HxWxD) in mm:	Built-in Dimensions (HxW) in mm:
44 x 590 x 520	560 x 490

HOBS

INDUCTION HOBS



60cm SenseBoil™
with DirekTouch

IAE64411FB

KEY FEATURES



SenseBoil™



DirekTouch
Slider



Slim
Installation



Hob2Hood



MaxiSense®

FUNCTIONS

AutoMax

Count Up Timer

Minute Minder

Eco Timer

Zone Booster

Stop & Go

Auto Off

Additional Features

Residual heat indicators

Child lock

Red LEDs

Bevelled 4 sides

Electricity loading 7350W

Energy Rating: N/A

**Appliance Dimensions
(HxWxD) in mm:**

44 x 590 x 520

**Built-in Dimensions
(HxW) in mm:**

560 x 490

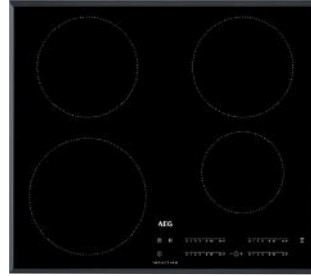

60cm
with DirekTouch

IKB64401FB

KEY FEATURES



DirekTouch
Slider



Slim
Installation



Hob2Hood



4 Cooking
Zones

FUNCTIONS

AutoMax

Count Up Timer

Minute Minder

Eco Timer

Zone Booster

Stop & Go

Auto Off

Additional Features

Residual heat indicators

Child lock

Red LEDs

Bevelled 4 sides

Electricity loading 7350W

Energy Rating: N/A

**Appliance Dimensions
(HxWxD) in mm:**

44 x 590 x 520

**Built-in Dimensions
(HxW) in mm:**

560 x 490

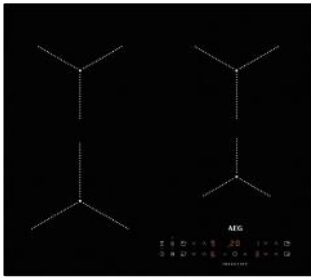

60cm Plug and Play
with Touch Control

ILB64334CB

KEY FEATURES



Touch Control



4 Cooking Zones



Hob2Hood



Slim Installation

FUNCTIONS

AutoMax	Zone Booster
Count Up Timer	Stop & Go
Minute Minder	Auto Off
Eco Timer	

Additional Features

Residual heat indicators	Frameless
Child lock	13 amp plug
Red LEDs	Electricity loading 7350W

Energy Rating: N/A

Appliance Dimensions (HxWxD) in mm:

44 x 590 x 520

Built-in Dimensions (HxW) in mm:

560 x 490

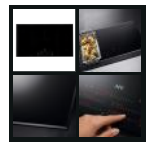

90cm MaxiSense®
with DirekTouch and Double Bridge

IKE95751FB

KEY FEATURES



MaxiSense®



DirekTouch Slider



Double Bridge



Slim Installation



PowerSlide



Hob2Hood

FUNCTIONS

AutoMax	Zone Booster
Count Up Timer	Pause
Minute Minder	Auto Off
Eco Timer	

Additional Features

Residual heat indicators	Bevelled 4 sides
Child lock	Electricity loading 7350W
Red LEDs	Pot detection

Energy Rating: N/A

Appliance Dimensions (HxWxD) in mm:

44 x 910 x 520

Built-in Dimensions (HxW) in mm:

880 x 490

HOB S

INDUCTION HOB



90cm Slim Depth MaxiSense®
with DirekTouch

IKK93431FB

KEY FEATURES



MaxiSense®



DirekTouch
Slider



Slim
Installation



3 Cooking
Zones

FUNCTIONS

AutoMax

Count Up Timer

Minute Minder

Eco Timer

Zone Booster

Stop & Go

Auto Off

Additional Features

Residual heat indicators

Child lock

Red LEDs

Bevelled 4 sides

Electricity loading 6900W

Energy Rating: N/A

**Appliance Dimensions
(HxWxD) in mm:**

44 x 910 x 410

**Built-in Dimensions
(HxW) in mm:**

880 x 380

CERAMIC HOB

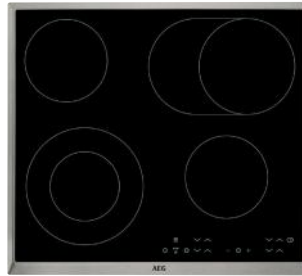

60cm
with Touch Control

HK634060XB

KEY FEATURES



Touch Control



DoubleZone



Extendable
Zone

FUNCTIONS

AutoMax

Count Up Timer

Minute Minder

Eco Timer

Stop & Go

Auto Off

Additional Features

Residual heat indicators

Child lock

Red LEDs

Steel frame

Electricity loading 7000W

Energy Rating: N/A

**Appliance Dimensions
(HxWxD) in mm:**

38 x 576 x 516

**Built-in Dimensions
(HxW) in mm:**

560 x 490



2L 20t
2 2

RAPID POWER

□ || 0 0 1 3 5
⊙ 13 0 1 3 5

AEG

GAS COOKING WITH ABSOLUTE ASSURANCE



TouchSure Hob

The advanced TouchSure hob from AEG comes with a range of reassuring safety features that provide absolute confidence in – and absolute command over – gas cooking. It's a traditional method harnessed with our responsive technology, instilling confidence to turn up the heat.



NOTHING COMPARES TO SEARING OVER A NAKED FLAME



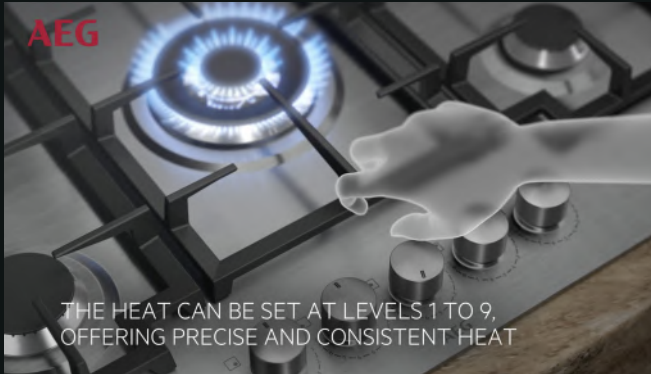

StepPower Controls

Thanks to StepPower the flame can be precisely set in 9 different levels to deliver reliable and consistent heat, every time. For cooking without guesswork.



StepPower with LED

LED lights with StepPower let you see the status of the hob at a glance. And residual heat indication shows whether pan supports are still hot after use.



Hob2Hood

The AEG Hob2Hood adapts to your cooking to keep your kitchen free of steam and vapours without you even having to touch it.

HOBS

GAS HOBS



90cm TouchSure Gas on Glass with Touch Control

HVB95450IB

KEY FEATURES

-  Touch Control
-  Hob2Hood
-  Minute Minder
-  Stop & Go
-  Cast Iron Pan Supports
-  Auto Ignition

FUNCTIONS

-  Wok Burner
-  1 Aux. Burner
-  3 Semi-rapid Burners

Additional Features

- Thermocouple
- Residual heat indicators
- Child lock

Energy Rating: N/A

Appliance Dimensions (HxWxD) in mm:

40 x 890 x 510

Built-in Dimensions (HxW) in mm:

850 x 490



90cm Gas on Glass with StepPower LED Rotary Controls

HKB95450NB

KEY FEATURES

-  StepPower Controls
-  Red LED Indicators
-  Hob2Hood
-  Minute Minder
-  Cast Iron Pan Supports
-  Auto Ignition

FUNCTIONS

-  Wok Burner
-  1 Aux. Burner
-  3 Semi-rapid Burners

Additional Features

- Thermocouple
- Residual heat indicators
- Red LEDs

Energy Rating: N/A

Appliance Dimensions (HxWxD) in mm:

40 x 880 x 510

Built-in Dimensions (HxW) in mm:

830 x 480



90cm Stainless Steel
with StepPower Rotary Controls

HGB95522YM

KEY FEATURES



StepPower
Controls



Rotary
Controls



Cast Iron Pan
Supports



Auto Ignition

FUNCTIONS



Wok Burner



1 Aux. Burner



2 Semi-rapid Burners



1 Rapid Burner

Additional Features

Thermocouple

Energy Rating: N/A

**Appliance Dimensions
(HxWxD) in mm:**

60 x 857 x 520

**Built-in Dimensions
(HxW) in mm:**

830 x 480



75cm TouchSure Gas on Glass
with Touch Control

HVB75450IB

KEY FEATURES



Touch Control



Hob2Hood



Minute
Minder



Stop & Go



Cast Iron Pan
Supports



Auto Ignition

FUNCTIONS



Wok Burner



1 Aux. Burner



3 Semi-rapid Burners

Additional Features

Thermocouple

Residual heat indicators

Energy Rating: N/A

**Appliance Dimensions
(HxWxD) in mm:**

52 x 750 x 510

**Built-in Dimensions
(HxW) in mm:**

720 x 490

HOB S

GAS HOB S

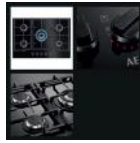

75cm Gas on Glass
with StepPower LED Rotary Controls

HKB75450NB

KEY FEATURES



StepPower Controls



Red LED Indicators



Hob2Hood



Minute Minder



Cast Iron Pan Supports



Auto Ignition

FUNCTIONS

 Wok Burner

 1 Aux. Burner

 3 Semi-rapid Burners

Additional Features

Thermocouple

Residual heat indicators

Energy Rating: N/A

Appliance Dimensions (HxWxD) in mm:

40 x 740 x 510

Built-in Dimensions (HxW) in mm:

560 x 480

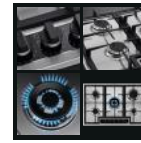

75cm Stainless Steel
with StepPower Rotary Controls

HGB75420YM

KEY FEATURES



StepPower Controls



Rotary Controls



Cast Iron Pan Supports



Auto Ignition





Efficient Burners

FUNCTIONS

 Wok Burner

 1 Aux. Burner

 2 Semi-rapid Burners

 1 Rapid Burner

Additional Features

Thermocouple

Energy Rating: N/A

Appliance Dimensions (HxWxD) in mm:

40 x 745 x 510

Built-in Dimensions (HxW) in mm:

560 x 480





60cm Gas on Glass
with StepPower LED Rotary Controls

HKB64450NB

KEY FEATURES

- 
StepPower Controls
- 
Red LED Indicators
- 
Cast Iron Pan Supports
- 
Auto Ignition
- 
Hob2Hood
- 
Minute Minder

FUNCTIONS

-  Wok Burner
 1 Aux. Burner
-  2 Semi-rapid Burners

Additional Features

Thermocouple
Residual heat indicators

Energy Rating: N/A

Appliance Dimensions (HxWxD) in mm:
40 x 590 x 520

Built-in Dimensions (HxW) in mm:
560 x 480





60cm Stainless Steel
with StepPower Rotary Controls

HGB64420YM

KEY FEATURES

- 
StepPower Controls
- 
Rotary Controls
- 
Cast Iron Pan Supports
- 
Auto Ignition
- 
Efficient Burners

FUNCTIONS

-  Wok Burner
 1 Aux. Burner
-  2 Semi-rapid Burners

Additional Features

Thermocouple

Energy Rating: N/A

Appliance Dimensions (HxWxD) in mm:
40 x 594 x 510

Built-in Dimensions (HxW) in mm:
560 x 480

HOB S

MIXED FUEL HOB

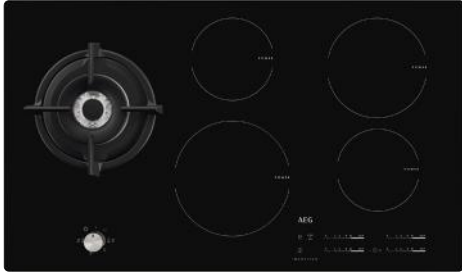

90cm Induction Hob and Gas Wok Burner with DirekTouch

HD955100NB

KEY FEATURES



DirekTouch Slider



Cast Iron Pan Supports



Auto Ignition

FUNCTIONS

Wok Burner

4 Induction Zones

Stop & Go

Minute Minder

Eco Timer

Additional Features

Thermocouple

Electricity loading 6800W

Child lock

Energy Rating: N/A

Appliance Dimensions (HxWxD) in mm:

47 x 880 x 520

Built-in Dimensions (HxW) in mm:

830 x 490

MODULAR HOB

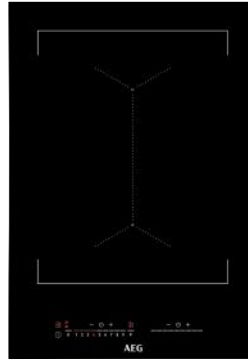

MaxiSense® 2 Zone Induction Hob with ActiveTouch

IKE42640KB

KEY FEATURES



MaxiSense®



ActiveTouch



Bridge Function



Slim Installation

FUNCTIONS

Wok Burner

Zone Booster

Count Up Timer

Stop & Go

Minute Minder

Auto Off

Eco Timer

Additional Features

Residual heat indicators

Red LEDs

Child lock

Electricity loading 3650W

Energy Rating: N/A

Appliance Dimensions (HxWxD) in mm:

44 x 360 x 520

Built-in Dimensions (HxW) in mm:

340 x 490

AEG

TOTALFLEX LETS YOU COOK ANYWHERE ON THE HOB'S SURFACE

The TotalFlex induction hob offers you maximum flexibility when cooking. Place pots and pans of all shapes and sizes almost anywhere across the hob's large responsive glass surface without compromising on space, taste or precision.

CHALLENGE THE EXPECTED



FREEDOM IN KITCHEN DESIGN

Plan your kitchen, and your cooking, with the freedom your creativity deserves. Without having to bother about cooker hoods, or the sizes of your pots and pans. Enjoy ultimate flexibility, with the **AEG Induction Hob with integrated Extractor**. It's your kitchen, your way..





Easy Installation

Our Optifix™ spring system is self-installing and self centering. Simply place the hob into your cut out for it to secure into place.



Easy Cleaning and Maintenance

The 2-in-1 Filter combines both a charcoal filter and grease filter that captures odours and grease, which can be easily removed for cleaning and maintenance. This Filter can be washed in the dishwasher and regenerated in the oven.



DirekTouch Slider

This hob's direct-access heat controls enable you to switch directly to exactly the right temperature with one touch. Simply touch the correct level on the slide control.

EXTRACTOR HOBS

EXTRACTOR HOBS



83cm Combined Hob & Hood
with DirekTouch and FlexiBridge®

CCE84779FB – Recirculation model

CDE84779FB – External ducted model

KEY FEATURES



DirekTouch
Slider



Double
FlexiBridge®



Easy
Installation



Connected



Hob2Hood



MaxiSense®



83cm Combined Hob & Hood
with Touch Control and Double Bridge Zone

CCE84751FB – Recirculation model

CDE84751FB – External ducted model

KEY FEATURES



DirekTouch
Slider



Double
Bridge



Easy
Installation



Hob2Hood



MaxiSense®

HOB FUNCTIONS

Count Up Timer

Auto Off

Minute Minder

Zone Booster

Eco Timer

Double FlexiBridge®

Pause

HOB FUNCTIONS

Count Up Timer

Auto Off

Minute Minder

Zone Booster

Eco Timer

Double Bridge

Pause

HOOD FUNCTIONS

3 Fan Speeds + Intensive

Auto

Breeze

2 in 1 Filters
(for Recirculation model)

HOOD FUNCTIONS

3 Fan Speeds + Intensive

Auto

Breeze

2 in 1 Filters
(for Recirculation model)

Additional Features

Residual heat indicators	Recirculation max 465 m ³ /h
Child lock	Recirculation intensive 585 m ³ /h
Red LEDs	Max noise 70dB(A)
Easy clean	Acoustic signal
Electricity loading 7400W	Filter Clean Indicator

Energy Rating: A+

**Appliance Dimensions
(HxWxD) in mm:**

210x830x515

**Built-in Dimensions
(HxW) in mm:**

780x490

Additional installation parts maybe required, depending on the install type

Additional Features

Residual heat indicators	Recirculation max 465 m ³ /h
Child lock	Recirculation intensive 585 m ³ /h
Red LEDs	Max noise 70dB(A)
Easy clean	Acoustic signal
Electricity loading 7400W	Filter Clean Indicator

Energy Rating: A+

**Appliance Dimensions
(HxWxD) in mm:**

210x830x515

**Built-in Dimensions
(HxW) in mm:**

780x490

Additional installation parts maybe required, depending on the install type



72cm Combined Hob & Hood
with Touch Control and Single Bridge Zone
IDE74243IB – Recirculation model

KEY FEATURES

- 
Touch Control
- 
Single Bridge
- 
Easy Installation
- 
Easy Clean
- 
Hob2Hood
- 
MaxiSense®

FUNCTIONS

-  Minute Minder
-  5 Fan Speeds
-  Auto Off
-  Single Bridge
-  Zone Booster
-  Stop & Go

Additional Features

- Child lock
- Recirculation max 365m³/h
- Red LEDs
- Recirculation intensive 515 m³/h
- Electricity loading 7400W
- Max noise 67dB(A)

Energy Rating: A

Appliance Dimensions	Built-in Dimensions
(HxWxD) in mm:	(HxW) in mm:
210 x 720 x 510	560 x 490

Model only available in Recirculation. All items for installation included

HOODS

Our cooking environments need to be fresh, bright and peaceful, enriching the time that we spend there. We use advanced technology to ensure that the design and build of our cooker hoods give you the optimum combination of high-end design and powerful functionality.



BREEZE FUNCTION

IN THIS SECTION

- Island Hoods
- Ceiling Hoods
- Chimney Hoods
- Integrated Hoods



SILENCE TECH



① 100% 100% 100% 100% 100%

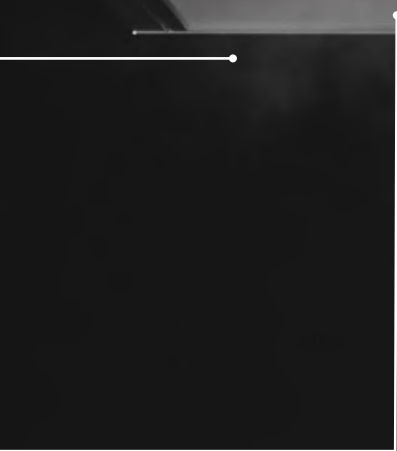

HOB2HOOD®



LED LIGHTING



COOK WITHOUT DISTRACTIONS



Hob2Hood

AEG Hob2Hood technology adapts to your cooking to keep your kitchen free of steam and vapours without you even having to touch it.

As you cook, the hood activates automatically, monitoring the fluctuating heat and steam of every simmer and boil, effortlessly maintaining the freshness of your kitchen. Your attention stays, as it should, on preparing, finessing and enjoying your dish.

AEG





SilenceTech

Our advanced hood technology allows Cooker Hoods to extract at a low 54dB, allowing you to enjoy the full cooking experience without loud sounds from your appliance.



Breeze Function

The breeze function quietly refreshes the air in your kitchen to create a more enjoyable atmosphere to relax or entertain. This function will automatically switch off for your convenience.



Touch on Glass Controls

Smooth and precise control of all your hood's functions with a simple touch on glass – easy to use and easy to clean.

HOOD ICONS

KEY FEATURES GUIDE



Hob2Hood

A wireless function that when paired with suitable hobs, it automatically activates and regulates the cooker hood according to your cooking activities. It provides a fresher kitchen environment so you can focus on achieving great taste.



Touch on Glass Controls

Smooth and precise control of all your hood's functions with a simple touch on glass – easy to use and easy to clean.



Push Button Controls

Precise control of the setting levels allowed through the squared push buttons.



Designer Filter Cover

High efficiency filter hidden with perfect black glass covers – the perfect look and easy to clean in the Dishwasher.



LED Lighting

LED lighting enables excellent visibility throughout the entire cooking process and provides ambient lighting in the kitchen.



Dimmable LED Lighting

Crisp bright illumination, or a gentle glow? Dimmer-controlled LED lighting means you can adjust the effect at the touch of a fingertip.



Black Glass

Beautiful design with unique black glass.



Anti Fingerprint Stainless Steel

The anti fingerprint stainless steel finishing protects the surface of your cooker hood from fingerprints.



Stainless Steel with Glass

Perfect combination of stainless steel and glass to create a unique and professional style in your kitchen.

FUNCTIONS



Fan Speeds

Number of fan speeds, allowing you to adjust the power, noise and energy consumption.



SilenceTech

Reduces the noise level down to our lowest number of decibels so that you can cook powerfully and enjoy all your favourite food without annoying sounds from the appliance.



Breeze Function

Refreshes the air in your kitchen after cooking at a very low noise level so that you have a more enjoyable and quiet atmosphere to relax or entertain.



Remote Control Included

Easy and fast control of all the hood's functions thanks to the remote control.

HOODS

ISLAND HOODS



90cm Pendant
with LED Lighting and Push Button Controls

DLE0970M

KEY FEATURES



Stainless Steel
with Glass



LED Lighting



Push Button
Controls

FUNCTIONS



4 Fan speeds



Remote Control Included

Additional Features

Recirculation Model Only

Noise: 42dB – 72dB

Motor speed: 700 m³/h

Energy Rating: N/A

Dimensions (HxWxD) in mm: (850–1250) 170 x 900 x 440



65cm Pendant
with LED Lighting and Push Button Controls

DLE0630B

KEY FEATURES



LED Lighting



Push Button
Controls

FUNCTIONS



4 Fan speeds



Remote Control Included

Additional Features

Recirculation Model Only

Noise: 44dB – 70dB

Motor speed: 350 m³/h

Energy Rating: N/A

Dimensions (HxWxD) in mm: (850–1250) 170 x 900 x 440

Also available: DLE0630W – White

HOODS

ISLAND HOODS



50cm Pendant
with LED Lighting and Push Button Controls

DLE0431W

KEY FEATURES



LED Lighting



Push Button
Controls

FUNCTIONS

4 Fan speeds

Remote Control Included

Additional Features

Recirculation Model Only

Motor speed: 350 m³/h

Noise: 44dB – 70dB

Energy Rating: N/A

Dimensions (HxWxD) in mm: (850–1250) x 500 x 500

Also available: DLE0431B – Black / DLE0431M – Stainless Steel



100cm T Shape
with Dimmable LED Lighting and Touch Controls

DIK6180HG

KEY FEATURES



Stainless Steel
with Glass



Touch on
Glass Controls



Hob2Hood



Dimmable LED
Lighting



Designer
Filter Cover

FUNCTIONS

5 Fan speeds

SilenceTech

Breeze Function

Additional Features

Charcoal filter included

Motor speed: 750 m³/h

Noise: 46dB – 65dB

Upgraded filter available
as an accessory

Energy Rating: A+

Dimensions (HxWxD) in mm: (1150–850) 75 x 1000 x 700



90cm T Shape
with Dimmable LED Lighting and Touch Controls
DIE5961HG

KEY FEATURES



Anti Fingerprint
Stainless Steel



Touch on
Glass Controls



Hob2Hood



Dimmable LED
Lighting

FUNCTIONS



4 Fan speeds



SilenceTech



Breeze Function

Additional Features

Recirculation Model Only

Upgraded filter available
as an accessory

Motor speed: 700 m³/h

Noise: 44dB – 65dB

Energy Rating: A

Dimensions (HxWxD) in mm: (1175–758) 60 x 898 x 606



90cm Downdraft
with LED Lighting and Touch Controls
DDE5980G

KEY FEATURES



Stainless Steel
with Black Glass



Touch on
Glass Controls



LED Strip
Lighting



Designer
Filter Cover

FUNCTIONS



5 Fan speeds



SilenceTech



Breeze Function

Additional Features

Charcoal filter included

Motor speed: 700 m³/h

Noise: 40dB – 70dB

Energy Rating: A

Dimensions (HxWxD) in mm: 407 x 880 x 95

HOODS

CEILING HOODS



120cm Ceiling
with Dimmable LED Lighting and Push Button Controls

DCK5281HG

KEY FEATURES



Stainless Steel
with White Glass



Push Button
Controls



Dimmable LED
Strip Lighting



Hob2Hood

FUNCTIONS

 4 Fan speeds

 Remote Control Included

Additional Features

Charcoal filter included

Motor speed: 720 m³/h

Noise: 57dB – 75dB

Upgraded filter available

as an accessory

Energy Rating: A+

Dimensions (HxWxD) in mm: (213) 3 x 1200 x 700



90cm Ceiling
with Dimmable LED Lighting and Push Button Controls

DCE5960HM

KEY FEATURES



Anti Fingerprint
Stainless Steel



Push Button
Controls





Dimmable LED
Strip Lighting



Hob2Hood

FUNCTIONS

 4 Fan speeds

 Remote Control Included

Additional Features

Charcoal filter included

Motor speed: 710 m³/h

Noise: 54dB – 67dB

Upgraded filter available

as an accessory

Energy Rating: A

Dimensions (HxWxD) in mm: (382–582) 3 x 900 x 700

WALL MOUNTED CHIMNEY HOODS



90cm Screen
with Dimmable LED Lighting and Touch Controls
DVK6981HR

KEY FEATURES



Touch on Glass Controls



Hob2Hood



Dimmable LED Strip Lighting

FUNCTIONS



5 Fan speeds



SilenceTech



Breeze Function

Additional Features

Charcoal filter included
Motor speed: 750 m³/h
Noise: 43dB – 54dB

Matt black chimney section included

Energy Rating: A+

Dimensions (HxWxD) in mm: (1260-915) 380 x 896 x 456



90cm / 60cm Screen
with LED Spotlights and Touch Controls
DVE5971HG / DVE5671HG

KEY FEATURES



Black Glass



Touch on Glass Controls



Hob2Hood



LED Spotlights

FUNCTIONS



4 Fan speeds



SilenceTech



Breeze Function

Additional Features

Charcoal filter included
Motor speed: 700 m³/h
Noise: 42dB – 64dB

Stainless steel chimney section included

Upgraded filter available as an accessory

Energy Rating: A

Dimensions (HxWxD) in mm:

DVE5971HG 90cm – (915-1265) 380 x 898 x 418

DVE5671HG 60cm – (915-1265) 380 x 598 x 418

HOODS

WALL MOUNTED CHIMNEY HOODS



90cm / 60cm T Shape
with Dimmable LED Lighting and Touch Controls
DBK6980HG / DBK6680HG

KEY FEATURES



Stainless Steel
with Glass



Touch on
Glass Controls



Hob2Hood



Dimmable LED
Strip Lighting



Designer
Filter Cover

FUNCTIONS

5 Fan speeds

SilenceTech

Breeze Function

Additional Features

Charcoal filter included

Upgraded filter available

Motor speed: 750 m³/h

as an accessory

Noise: 46dB – 65dB

Energy Rating: A+

Dimensions (HxWxD) in mm:

DBK6980HG 90cm – (773–1218) 75 x 898 x 455

DBK6680HG 60cm – (773–1218) 75 x 598 x 455



90cm / 70cm / 60cm T Shape
with LED Lighting and Touch Controls
DBE5961HG / DBE5761HG / DBE5661HG

KEY FEATURES



Anti Fingerprint
Stainless Steel



Touch on
Glass Controls



Hob2Hood



LED Lighting

FUNCTIONS

4 Fan speeds

SilenceTech

Breeze Function

Additional Features

Charcoal filter included

Upgraded filter available

Motor speed: 700 m³/h

as an accessory

Noise: 44dB – 65dB

Energy Rating: A

Dimensions (HxWxD) in mm:

DBE5961HG 90cm – (759–1204) 60 x 898 x 455

DBE5761HG 70cm – (759–1204) 60 x 698 x 455

DBE5661HG 60cm – (759–1204) 60 x 598 x 455



90cm / 60cm Pyramid
with LED Lighting and Push Button Controls
DKB4950M / DKB4650M

KEY FEATURES



Anti Fingerprint
Stainless Steel



Push Button
Controls



LED Lighting

FUNCTIONS

3 Fan speeds

Additional Features

Charcoal filter included
Motor speed: 603 m³/h
Noise: 46dB – 69dB

Upgraded filter available
as an accessory

Energy Rating: B

Dimensions (HxWxD) in mm:

DKB4950M 90cm – (1090–665) 40 x 898 x 500
DKB4650M 60cm – (1090–665) 40 x 598 x 500

INTEGRATED HOODS



80cm / 54cm Hidden
with LED Lighting and Push Button Controls
DGE5861HM / DGE5661HM

KEY FEATURES



Anti Fingerprint
Stainless Steel



Push Button
Controls



LED Lighting



Hob2Hood

FUNCTIONS

4 Fan speeds

Remote Control Included

Additional Features

Charcoal filter included
Motor speed: 700 m³/h
Noise: 54dB – 68dB

Upgraded filter available
as an accessory

Energy Rating: A

Dimensions (HxWxD) in mm:

DGE5861HM 80cm – 331 x 770 x 300
DGE5661HM 54cm – 331 x 540 x 300

HOODS

INTEGRATED HOODS



80cm / 54cm Hidden
with LED Lighting and Push Button Controls
DGE5861HB / DGE5661HB

KEY FEATURES



Anti Fingerprint
Stainless Steel



Push Button
Controls



LED Lighting



Hob2Hood

FUNCTIONS

 4 Fan speeds

 Remote Control Included

Additional Features

Charcoal filter included

Upgraded filter available
as an accessory

Motor speed: 700 m³/h

Noise: 54dB – 68dB

Energy Rating: A

Dimensions (HxWxD) in mm:

DGE5861HB 80cm – 331 x 770 x 300

DGE5661HB 54cm – 331 x 540 x 300

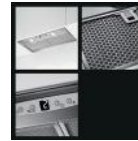

70cm Hidden
with LED Lighting and Push Button Controls
DGB3850M

KEY FEATURES



Anti Fingerprint
Stainless Steel



Push Button
Controls



LED Lighting

FUNCTIONS

 4 Fan speeds

Additional Features

Charcoal filter included

Upgraded filter available
as an accessory

Motor speed: 600 m³/h

Noise: 49dB – 63dB

Energy Rating: C

Dimensions (HxWxD) in mm: 245 x 700 x 285



90cm / 60cm Pull Out
with LED Lighting and Push Button Controls
DPB3932S / DPB3632S updated model

KEY FEATURES



Silver



Push Button Controls



LED Lighting

FUNCTIONS

 3 Fan speeds

Additional Features

Charcoal filter included
Motor speed: 370 m³/h
Noise: 48dB – 68dB

Energy Rating: C

Dimensions (HxWxD) in mm:

DPB3932S 90cm – (179) 40 x 898 x 284

DPB3632S 60cm – (179) 40 x 598 x 284



60cm Hidden
with LED Lighting and Slider Controls
DEB2631S

KEY FEATURES



Silver



Slider Control



LED Lighting

FUNCTIONS

 2 Fan speeds

Additional Features

Charcoal filter included
Motor speed: 352 m³/h
Noise: 47dB – 62dB

Energy Rating: D

Dimensions (HxWxD) in mm: 400 x 598 x 270

DISHWASHERS

It's not just about the food – the style of cutlery and plates affect our perceptions of what we eat. A dark chocolate dish looks best when served on an angular plate, while a round plate is better for cheesecake. So you need a range of tableware that complements your food presentation and can be cared for in the most efficient way.



GLASSCARE

IN THIS SECTION

Fully Integrated Dishwashers

Slimline Fully Integrated Dishwasher



QUICKSELECT



PROCLEAN



COMFORTLIFT®

BRING YOUR DISHES TO YOUR LEVEL



ComfortLift®

Raise your standards – and the lower basket of your dishwasher to a more convenient level with ComfortLift® technology. The ComfortLift® dishwasher is the first of its kind to gently slide the lower basket up for easy, ergonomic loading and unloading. That means less bending down, to make your life more comfortable.

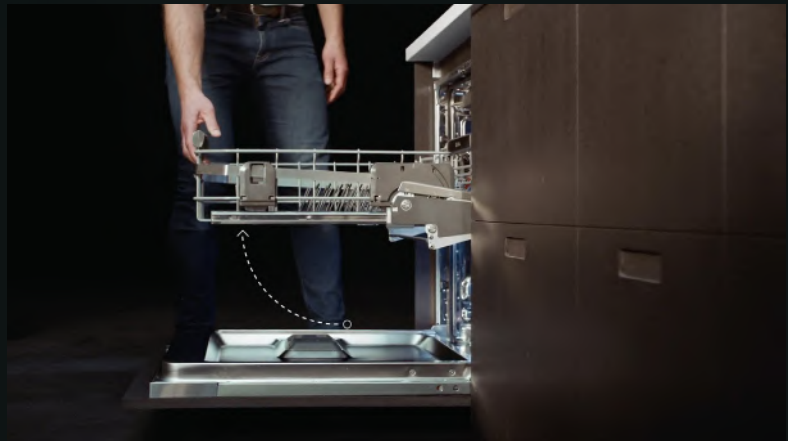

SatelliteClean

The double rotating spray arm leaves every load spotless, delivering three-times better spray coverage with no extra water.





QuickSelect

An intuitive slider lets you control your dishwasher on your own terms. Simple, premium control that adapts the wash according to your lifestyle, allowing you to select when you want your dishes clean. The machine does the rest.



AirDry Technology

Uses natural airflow to finish the drying. By automatically opening the door by 10cm in the last part of the cycle, you will get maximum drying performance while effectively reducing your energy costs – leaving your dishes spotless.



Sliding Hinge

Allows you to install the dishwasher with any door length without the need to cut the kitchen plinth. This is also suitable for plinthless kitchens. The best solution on the market – patented by AEG.



MaxiFlex

The MaxiFlex drawer from AEG accommodates almost everything. From multiple cutlery sets to oversized utensils. Flexible dividers mean every load is customisable.

SUPERIOR CLEANING AND FULL COVERAGE

With our ProClean range of dishwashers we deliver superior cleaning and drying, ensuring that you can clean more at the same time and get a great cleaning result with superb drying.



ProClean

Our ProClean models have a larger usable internal space, combined with five spray levels, satellite and ceiling spray arm plus GlassCare package..

5 Spray Levels

Multi level spray reaches every item anywhere, giving you our most efficient spray coverage.

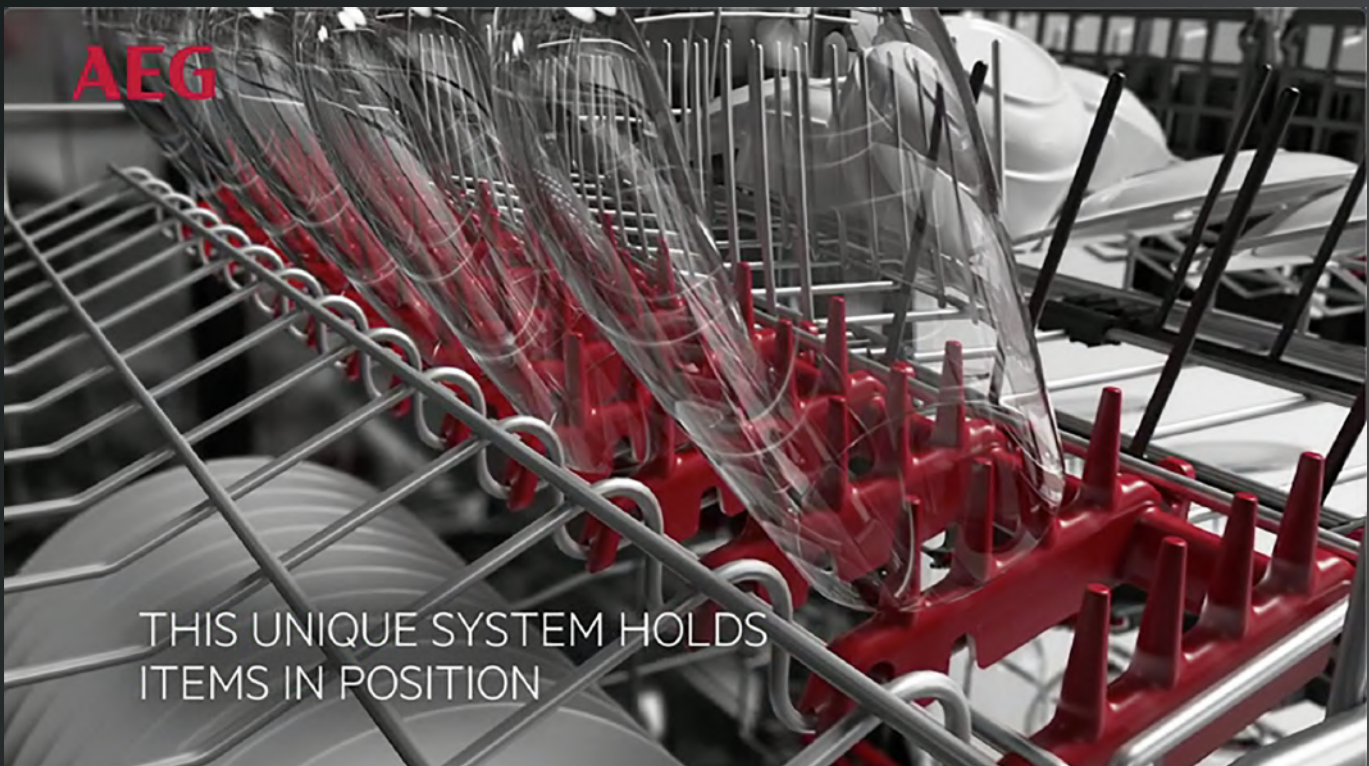
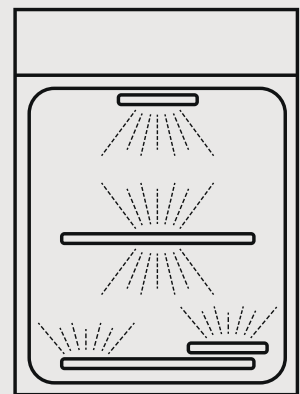

THIS UNIQUE SYSTEM HOLDS
ITEMS IN POSITION



Glass Care Programme

A Special 45°C glass programme ensures perfect washing results while protecting your most precious glass, crystal and china.



XXL Interiors

The XXL interior of this dishwasher gives you an additional 10 litres of space – more capacity for those irregular shaped items.



SprayZone

Heavily soiled items, such as lasagne or crumble dishes, can be washed with a normal load with SprayZone. This feature activates a dedicated zone designed specifically for dishes with stubborn residue.

Features	Standard Models	ProClean	Benefits
Internal Space	Suitable for plate sizes up to 31cm diameter	Suitable for plate sizes up to 33cm diameter	Fit more dishes in!
Spray Levels	2 – 4	5	More spray levels for better cleaning.
Satellite Spray Arm	Selected models	Included as standard	Sprays from continuously varying angles and covers a lot more area compared to a standard spray arm.
Ceiling Spray Arm	Selected models	Included as standard	More spray levels for better cleaning
GlassCare Package	Selected models	Full package included as standard	Protects delicate glasses with soft grips, soft spikes and a dedicated glass programme. No more hand washing old and fragile glass.

DISHWASHER ICONS

KEY FEATURES GUIDE



ComfortLift®

The ComfortLift® basket rises on special hinges, ensuring less bending when loading and unloading dishes.



SprayZone

Heavily soiled items, such as lasagne or crumble dishes, can be washed with a normal load by selecting the SprayZone option.



MaxiFlex

The MaxiFlex drawer from AEG accommodates almost everything. From multiple cutlery sets to over-sized utensils.



Connected

Control and monitor your dishwasher remotely by connecting it to the 'My AEG Kitchen' app. This allows you to choose and customise programmes, follow step by step maintenance and even alerts you when the rinse aid and salt is running low.



GlassCare package

Delicate wine glasses are protected with our soft spikes, soft grips and dedicated GlassCare 45°C programme.



ProClean

Our ProClean models have a larger usable internal space, combined with five spray levels, satellite and ceiling spray arm plus GlassCare package.



QuickSelect

Simple, premium control that adapts the wash according to your needs, allowing you to select when you want your dishes clean.



InteriorLight

Locate items at a glance thanks to the bright internal light.



24 Hour Time Delay

Run your dishwasher when it suits you, thanks to the up to 24 hour delay start function.



TimeBeam

Keeps you informed on the progress of the programme by projecting the remaining time on the floor.



TimeSaver Function

50% less time thanks to increased power speed and water pressure.



Sliding Hinge

With this dishwasher you can choose to install it normally above a plinth. Alternatively, the sliding hinge is perfect for plinthless kitchens or for installation above a small cupboard.



XXL Interior

The XXL interior of this dishwasher gives you an additional 10 litres of space, more capacity for those irregular shaped items and plates up to 33cm in diameter.



AirDry

Uses natural airflow to finish the drying. By automatically opening the door by 10cm in the last part of the cycle, you will get maximum drying performance leaving your dishes spotless.



SatelliteClean®

The double rotating spray arm leaves every load spotless, delivering three-times better spray coverage with no extra water.



Light Beam

This dishwasher is so quiet it projects a tiny red or green beam on to the floor to tell you when it's running and when it's finished.



Deluxe Interior

Selected models have a higher level of internal finish, including stainless steel drawer handles and knife supports in the cutlery drawer.



Dual Spray Arm (slimline)

Water is evenly distributed in every dishwashing cycle with the dual spray arms. The rotating sprinklers make sure water gets into every corner, so your dishes come out sparkling.

DISHWASHERS

The AEG range of dishwashers is designed to meet the frustrations and needs of dishwasher users. The models are designed to give a better quality wash and superb drying results, combined with a larger capacity and useful features such as our glasscare package which looks after your best wine glasses.

FULLY INTEGRATED DISHWASHERS



ComfortLift®
with Internal Light, TimeBeam and Cutlery Drawer
FSK93847P

KEY FEATURES



ComfortLift®



Interior Light



TimeBeam



ProClean



AirDry



Deluxe Interior



XXL interior



QuickSelect

GlassCare
package

Sliding hinge

ComfortLift®

The AEG ComfortLift® dishwasher is equipped with a special lower rack lifting mechanism, ensuring less bending when unloading the dishes to make your life more comfortable.

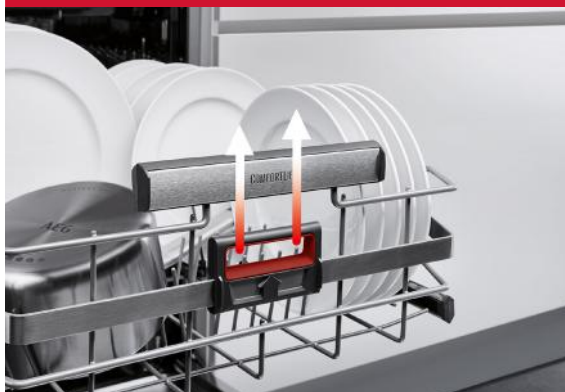

PROGRAMMES – 7

160mins	Eco
90mins	Machine Care
60mins	30min 60°
Auto 45° – 70°	

Additional Features

Auto load adjust: Sensor logic	Cutlery drawer
24 hour delay	XtraDry
Glass care option	Soft spikes and soft grips
Extra silent option	Anti-flood protection
Xtra power option	

Place Settings: 14
Noise Level: 39dB
Energy Rating: D
Noise Rating: B

Water Usage: 11 ltr
Appliance Dimensions (HxWxD) in mm:
818 x 596 x 550

DISHWASHERS

FULLY INTEGRATED DISHWASHERS



ComfortLift®
with LightBeam and Cutlery Drawer

FSE83837P

KEY FEATURES



ComfortLift®



Light Beam



ProClean



AirDry



XXL interior



QuickSelect



GlassCare
Package



Sliding hinge



24 Hour
Time Delay



MaxiFlex



ProClean
with LightBeam, Glass Holder and Cutlery Drawer

FSE74747P

KEY FEATURES



ProClean



Light Beam



GlassCare
Package



AirDry



XXL interior



QuickSelect



Sliding hinge



24 Hour
Time Delay



MaxiFlex

PROGRAMMES - 7

160mins	Eco
90mins	Machine Care
60mins	30min 60°
Auto 45° - 70°	

Additional Features

Auto load adjust: Sensor logic	Cutlery drawer
Xtra power option	XtraDry
Glass care option	Soft spikes and soft grips
Extra silent option	Anti-flood protection
Flexible basket	

Place Settings: 14
Noise Level: 44dB
Energy Rating: D
Noise Rating: B

Water Usage: 11 ltr
Appliance Dimensions (HxWxD) in mm:
818 x 596 x 550

PROGRAMMES - 7

160mins	Eco
90mins	Machine Care
60mins	30min 60°
Auto 45° - 70°	

Additional Features

Auto load adjust: Sensor logic	Cutlery drawer
Xtra power option	XtraDry
Glass care option	Soft spikes and soft grips
Extra silent option	Anti-flood protection
Lower basket glass holder	

Place Settings: 15
Noise Level: 44dB
Energy Rating: C
Noise Rating: B

Water Usage: 11 ltr
Appliance Dimensions (HxWxD) in mm:
818 x 596 x 550



ProClean
with TimeBeam and Cutlery Drawer
FSK75757P

KEY FEATURES

- ProClean
- TimeBeam
- GlassCare Package
- AirDry
- XXL interior
- QuickSelect
- Sliding hinge
- 24 Hour Time Delay
- MaxiFlex

PROGRAMMES – 7

160mins	Eco
90mins	Machine Care
60mins	30min 60°
Auto 45° – 70°	

Additional Features

- Auto load adjust: Sensor logic XtraDry
- Xtra power option Soft spikes and soft grips
- Glass care option Anti-flood protection
- Extra silent option Internal light
- Cutlery drawer

Place Settings: 14 **Water Usage:** 9.9 ltr
Noise Level: 42dB **Appliance Dimensions**
Energy Rating: B **(HxWxD) in mm:**
Noise Rating: B 818 x 596 x 550



ProClean
with LightBeam, SprayZone and Cutlery Basket
FSS63607P

KEY FEATURES

- ProClean
- Light Beam
- SprayZone
- AirDry
- XXL interior
- QuickSelect
- GlassCare Package
- Sliding hinge
- 24 Hour Time Delay

PROGRAMMES – 7

160mins	Eco
90mins	Machine Care
60mins	30min 60°
Auto 45° – 70°	

Additional Features

- Auto load adjust: Sensor logic Cutlery basket
- Xtra power option XtraDry
- Glass care option Soft spikes and soft grips
- Extra silent option Anti-flood protection
- SprayZone

Place Settings: 13 **Water Usage:** 10.5 ltr
Noise Level: 44dB **Appliance Dimensions**
Energy Rating: D **(HxWxD) in mm:**
Noise Rating: B 818 x 596 x 550

DISHWASHERS

FULLY INTEGRATED DISHWASHERS

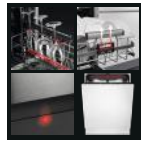

QuickSelect
with LightBeam and Cutlery Drawer

FSK52917Z

KEY FEATURES



QuickSelect



Light Beam



MaxiFlex



AirDry



SatelliteClean®



GlassCare
Package



Sliding hinge



24 Hour
Time Delay

PROGRAMMES – 7

160mins	Eco
90mins	Machine Care
60mins	30min 60°
Auto 45° – 70°	

Additional Features

Auto load adjust: Sensor logic	Cutlery drawer
Auto off	XtraDry
Glass care option	Anti-flood protection
Xtra power option	Soft spikes
Lower basket glass holder	

Place Settings: 14

Noise Level: 44dB

Energy Rating: E

Noise Rating: B

Water Usage: 10.5 ltr

**Appliance Dimensions
(HxWxD) in mm:**

818 x 596 x 550

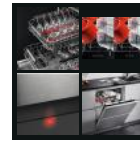

QuickSelect
with AirDry Technology and Cutlery Basket

FSB42607Z

KEY FEATURES



QuickSelect



AirDry



24 Hour
Time Delay



Sliding hinge

PROGRAMMES – 5

90mins	30min 60°
Auto 45° – 70°	
Eco	
Machine Care	

Additional Features

Auto load adjust: Sensor logic	Anti-flood protection
Xtra power option	
Flexible basket	
XtraDry	
Cutlery basket	

Place Settings: 13

Noise Level: 46dB

Energy Rating: E

Noise Rating: C

Water Usage: 9.9 ltr

**Appliance Dimensions
(HxWxD) in mm:**

818 x 596 x 550

SLIMLINE FULLY INTEGRATED DISHWASHER



QuickSelect
with AirDry Technology and Cutlery Drawer

FSE72507P

KEY FEATURES



QuickSelect



AirDry



MaxiFlex



SatelliteClean®



GlassCare
Package



Sliding hinge



Light Beam



24 Hour
Time Delay



Dual Spray
Arm

PROGRAMMES – 7

160mins

Eco

90mins

Machine Care

60mins

30min 60°

Auto 45° – 70°

Additional Features

Auto load adjust: Sensor logic

Flexible basket

Auto off

XtraDry

Glass care

Anti-flood protection

Soft spikes

Cutlery drawer

Place Settings: 10

Water Usage: 9.9 ltr

Noise Level: 44dB

Appliance Dimensions

Energy Rating: E

(HxWxD) in mm:

Noise Rating: B

818 x 446 x 550

WHY COMPROMISE ON CARE?

Since AEG began in 1883, we have always set new challenges. Why trust your most precious clothes to the dry cleaners? Why waste valuable energy, water and time on a wash cycle? AEG gives you the confidence to redefine the expected.

No need for compromises. Let's demand a higher standard for laundry care... and the environment.



LAUNDRY

Imagine putting your precious sweater in the washer. Imagine trusting a dryer with a silk dress.

We've not only imagined it, we've done it. Washed the black dress time after time. Dried a soft wool sweater over and over. Every time they emerge without shrinking or fading, still vibrant and soft. Because AEG has redefined what a washer and dryer are. Protectors of fabric. Defenders of colour. Guardians of fibres.

Unprecedented care for the life of your clothes. Imagine that.

IN THIS SECTION

Built-In Washing Machine

Built-In Washer Dryer

Freestanding Washing Machines

Freestanding Tumble Dryers

Freestanding Washer Dryers



DESIGNED WITH CARE

Our unique, innovative design is more than a pretty face. It also conveys superior quality and technical advancement. For our new range, we increased the size of the door and porthole for ease of use and a modern look, and reinvented the control panel.





Premium Design

We've been inspired by the electric turbines manufactured at the AEG Turbine Factory in Berlin.

The positioning of the door handle at 2 o'clock makes it easy to open.



Easy to Use Control Panel

A total self-cleaning function that automatically locks the oven door and heats up to 500°C, turning food residue to ash.



Complementary Design

AEG Tumble dryers are designed to complement our washing machines and are available with stacking kits.







Built-In Laundry

Achieve that seamless look with our built-in range. Our integrated washing machines feature the same wide variety of functionalities as our freestanding ones, including ProSteam® and ProSense® technology.

OUR WASHING MACHINE RANGE

Our washing machine range is structured into 4 series levels. As you go up the series levels, our washing machines step up in the level of fabric care, and include all the technologies from the series below.

With our freestanding and built-in washing machine ranges both packed full of technology, you don't have to compromise on washing performance.

Features	6000 SERIES	7000 SERIES	8000 SERIES	9000 SERIES
 SoftWater Technology				✓
 ÖKOMix Technology			✓	✓
 ProSteam® Technology		✓	✓	✓
 ProSense® Technology	✓	✓	✓	✓





FULL STEAM AHEAD



ProSteam®

Why needlessly waste water, energy and your time? By steaming instead of washing, you can refresh and remove creases from your clothes in just 25 mins – saving more than 40 litres of water*. Helping you care for your wardrobe and the planet.

↓ **96%**

less water than a normal wash

↓ **25 MINS**

to refresh, revice and uncrease fabrics

↓ **30%**

fewer creases when steam is added to the wash cycle

AEG



PROSTEAM® TECHNOLOGY OFFERS A WASH CYCLE WITH A PLUSSTEAM OPTION OR A SEPARATE STEAM PROGRAMME

*Use steam to refresh clothes and save more than 40l of water per cycle, tested on 1kg delicate garments using the FreshScent programme compared to using the Delicates programme.



AEG

1000 SERIES T | LAVAMAT
SoftWater Technology 4.0p

Programme
Wash show
Cotton ECO
Cotton
Synthetic
Delicate
Wool
2000 Jitters
2000c - 21g
Steam
SpinDrum

15 25

Temperature 90% Delayed Program Extra Rinse Start

Quick Pick Steam Time Lock Star Protect

NO FADING, WASH AFTER WASH*



SoftWater

The AEG SoftWater® technology purifies and softens water by filtering out unwanted substances like calcium and magnesium.

Not only will this allow you to lower the temperature and save energy - it will also prevent colours from fading, and preserve the shape and softness of your favourite clothes.

Available on 9000 series washing machines.



ALL MAINS WATER CONTAINS MINERALS THAT CAN BE HARSH ON FABRICS

*Even after 50 washes, colours will keep their intensity and black won't fade to grey. Test for colourfastness performed on black polyester after 50 washing cycles at 30°C.

WASHED WITHOUT
SOFTWATER TECHNOLOGY

WASHED WITH
SOFTWATER TECHNOLOGY

SHAPE LOSS

NEW GARMENT

AFTER 50 WASHES



AEG



ÖKOMIX TECHNOLOGY
PRE-MIXES DETERGENTS
AND SOFTENER SEPARATELY IN WATER



ÖKOMix

Unique pre-mixing of detergent, softener and water to reach every fibre.

AEG



IN AEG WASHING MACHINES, EVERY LOAD IS WEIGHED TO TAILOR EACH CYCLE



ProSense®

Adjusts time, water and energy consumption to the size of the load, even if it is just a single shirt or your entire weekly wash. This is thanks to specific sensors that will intelligently control the cycle settings and take care that your clothes are only washed for the exact amount of time needed.

AEG



NEVER TOO MUCH AND NEVER TOO LITTLE.
JUST PRECISE DOSAGE.





AutoDose

Intelligent technology senses the weight of the load and automatically calculates the optimal amount of detergent and softener to add to each wash cycle. Ensuring your whites stay bright and colours keep their vitality, wash after wash.

OUR TUMBLE DRYER RANGE

Our tumble dryer range is structured into 3 series levels. As you go up the series levels, our tumble dryers step up the level of fabric care, and include all the technologies from the series below.

Features	6000 SERIES	7000 SERIES	8000 SERIES
 AbsoluteCare® System			✓
 SensiDry® Technology		✓	✓
 ProSense® Technology	✓	✓	✓



AEG



ABSOLUTE CARE® SYSTEM
CONTROLS PRECISELY THE TEMPERATURE
AND MOVEMENT OF THE DRUM



AbsoluteCare® System

AbsoluteCare® System, a tailored program that precisely controls the movement and temperature of the drying drum. Delicate woollens with 'hand wash only' care labels are kept flat against the drum during rotations to replicate flat drying.

AEG

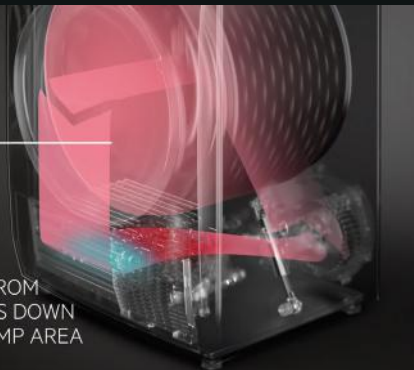

THE HUMID AIR FROM
THE DRUM MOVES DOWN
TO THE HEAT PUMP AREA



SensiDry®

Using low temperatures without extending drying times, AEG SensiDry® Technology ensures that garments are never subjected to unnecessary heat.

AEG



PROSENSE® TECHNOLOGY USES ADVANCED
HUMIDITY AND TEMPERATURE SENSORS





ProSense®

ProSense technology, which uses advanced humidity and temperature sensors to adjust the drying time and energy consumption for every size of load - whether it's a day's or a week's worth of washing.

OUR WASHER DRYER RANGE

We've taken the best technologies of our washing machines and tumble dryers and incorporated them into our washer dryers and incorporated them into our washer dryers, such as ProSense® and ProSteam® which can be found within our 7000 series.

Features	7000 SERIES
 ProSense® Technology	<input checked="" type="checkbox"/>
 ProSteam® Technology	<input checked="" type="checkbox"/>
 DualSense® Technology	<input checked="" type="checkbox"/>



AEG



DEDICATED WASH AND DRY
CYCLES FOR OUTDOOR WEAR
CLEAN AND PROTECT TECHNICAL FABRICS



DualSense®

DualSense® technology tailors the temperature and motion of the drum to different fabrics. Everything from textured jackets to soft jumpers can be carefully washed, dried and cared for in one go.

AEG

ÖKOMIX TECHNOLOGY
PRE-MIXES DETERGENTS
AND SOFTENER SEPARATELY IN WATER



ÖKOMix

Unique pre-mixing of detergent, softener and water to reach every fibre.

AEG

PROSENSE® TECHNOLOGY USES ADVANCED
HUMIDITY AND TEMPERATURE SENSORS



ProSense®

ProSense technology, which uses advanced humidity and temperature sensors to adjust the drying time and energy consumption for every size of load - whether it's a day's or a week's worth of washing.

AEG

PROSTEAM® TECHNOLOGY
OFFERS A WASH CYCLE WITH A PLUSSTEAM
OPTION OR A SEPARATE STEAM PROGRAMME



ProSteam®

Using the PlusSteam® option to end a washing cycle with steam, reduces creasing by up to 30%. You can also refresh clothes with a separate steam programme to remove unwanted odours from garments.

BUILT-IN RANGE

Achieve that seamless look with an integrated washing machine or washer dryer. Our integrated machines feature the same wide variety of functionalities as our freestanding ones, including ProSteam®, ProSense® and DualSense® technology.

WASHING MACHINE



7000 Series
with ProSteam® and ProSense®

L7FC8432BI

TECHNOLOGY



ProSteam®



ProSense®

SPECIFICATIONS

Drum: 8kg

Energy rating: D

Speed: 1400rpm

Speed: B

PROGRAMMES

Eco 40-60	Rinse
Cottons	Anti Allergy
Synthetics	Duvet
Delicates	20min – 3kg
Outdoor	Sport
Steam	Denim
Spin/Drain	Wool/Silk

Additional Features

Temperature Selection	Plus Steam
Spin Selection	Delayed Start
Stain	Time Saving
Extra Rinse	Start/Pause
Soft Plus	

Colour: Silver fascia panel

Appliance Dimensions (HxWxD) in mm: 820 x 596 x 555



ProSteam®

Using the PlusSteam® option to end a washing cycle with steam, reduces creasing by up to 30%. You can also refresh clothes with a separate steam programme to remove unwanted odours from garments.

WASHER DRYER



7000 Series, 7/4kg
with DualSense® and ProSense®

L7WC8632BI

TECHNOLOGY



DualSense®



ProSense®

SPECIFICATIONS

Drum: 7/4kg	Energy rating: D / E
Speed: 1600rpm	Speed: B

PROGRAMMES

Eco 40-60	Rinse
Cottons	Machine Clean
Synthetics	Anti Allergy
Delicates	Sport Wear
Wool/Handwash	Outdoor
Steam	Denim
Spin/Drain	Non Stop 60min

Additional Features

Temperature Selection	Dry Mode
Spin Selection	Drying Time
Prewash	Autodry
Stain	Start/Pause
Time Saving	Delayed Start

Colour: Silver fascia panel

Appliance Dimensions (HxWxD) in mm: 820 x 596 x 555



DualSense®

DualSense® technology tailors the temperature and motion of the drum to different fabrics. Everything from textured jackets to soft jumpers can be carefully washed, dried and cared for in one go.

FREESTANDING RANGE

WASHING MACHINES

While conventional washing machines need high temperatures to activate detergents and clean properly, the SoftWater technology in AEG 9000 Series washing machines purifies and softens water before it enters the drum.



9000 Series
with SoftWater and ÖKOMix
L9FEC966R

TECHNOLOGY



SoftWater



ÖKOMix



ProSteam®



ProSense®

SPECIFICATIONS

Drum: 9kg

Energy rating: A

Speed: 1600rpm

Speed: B

PROGRAMMES

Eco 40-60

Steam

Cottons

ÖKOPower

Synthetics

20min – 3kg

ColourPro

Outdoor

Delicates

Anti Allergy

Wool/Silk

Additional Features

Soft Plus

Start/Pause

PlusSteam®

Stains/Prewash

Time save

Rinse

Delay start

Extra rinse

Temperature selection

Child lock

Spin selection

Colour: Stainless steel fascia panel

Appliance Dimensions (HxWxD) in mm: 850 x 600 x 660

Softer water, kinder to clothes

Because our advanced SoftWater technology purifies and softens water before it enters the drum, detergents can work much more effectively at low temperatures, delivering 60°C cleaning performance at only 30°C. So colours will keep their intensity wash after wash, and black won't fade to grey.



NEW DRESS

AFTER 50 WASHES



8000 Series
with ÖKOMix and ProSteam®

L8FEE965R

TECHNOLOGY



ÖKOMix



ProSteam®



ProSense®

SPECIFICATIONS

Drum: 9kg

Energy rating: A

Speed: 1600rpm

Speed: B

PROGRAMMES

Eco 40-60	ÖKOPower
Cottons	20min – 3kg
Synthetics	Outdoor
Delicates	Duvet
Wool/Silk	Anti Allergy
Steam	

Additional Features

PlusSteam®	Stains/Prewash
Time save	Rinse
Delay start	Extra rinse
Temperature selection	Child lock
Spin selection	
Start/Pause	

Colour: Stainless steel fascia panel

Appliance Dimensions (HxWxD) in mm: 850 x 600 x 660



7000 Series
with ProSteam® and ProSense®

L7FEE845R

TECHNOLOGY



ProSteam®



ProSense®

SPECIFICATIONS

Drum: 8kg

Energy rating: C

Speed: 1400rpm

Speed: B

PROGRAMMES

Eco 40-60	20min – 3kg
Cottons	Outdoor
Synthetics	Duvet
Delicates	Sport
Wool/Silk	Anti Allergy
Steam	

Additional Features

Soft Plus	Start/Pause
PlusSteam®	Stains/Prewash
Time save	Rinse
Delay start	Extra rinse
Temperature selection	Child lock
Spin selection	

Colour: Silver fascia panel

Appliance Dimensions (HxWxD) in mm: 850 x 600 x 660

FREESTANDING RANGE

WASHING MACHINES



6000 Series AutoDose®
with ProSense®
L6FBG941CA

TECHNOLOGY



AutoDose®



ProSense®

SPECIFICATIONS

Drum: 9kg

Energy rating: A

Speed: 1400rpm

Speed: B

PROGRAMMES

Cottons

Anti Allergy

Eco 40-60

Quick 20min – 3kg

Synthetics

Outdoor

Delicates

Easy Iron

Wool/Silk

Spin/Drain

Additional Features

Time save

Temperature selection

Delay

Spin selection

Start/Pause

Intensive/Prewash

Colour: White fascia panel

Appliance Dimensions (HxWxD) in mm: 850 x 600 x 660



ProSense®

Adjusts time, water and energy consumption to the size of the load, even if it is just a single shirt or your entire weekly wash. This is thanks to specific sensors that will intelligently control the cycle settings and take care that your clothes are only washed for the exact amount of time needed

AWARD WINNING QUALITY.



Woolmark

The Woolmark Apparel Care programme helps consumers identify quality laundry appliances that are approved by The Woolmark Company for use on woollen fabrics.

Woolmark Blue

It is the Woolmark Apparel Care certification of wool cycles that identifies a machine as safe in which to wash handwash only woollen fabrics.

Woolmark Green

The gentleness required is exactly the same as for Woolmark Blue, but the programme uses less energy and water, hence the symbolic green labelling.



Ariel and Lenor certified

Our washing machine range is certified by Ariel and Lenor for their efficient use of liquid detergent and fabric softener. Any machine with ÖKOMix technology has received the premium certification by Ariel and Lenor. The certification guarantees that 90% of fabrics in a washing load are evenly covered with liquid fabric softener. AEG, Ariel and Lenor have partnered to provide you with their combined unique care expertise for fabrics.



FREESTANDING RANGE

TUMBLE DRYERS

Never dared to tumble dry wool, silk or outdoor garments before? Now you can tumble dry everything you wash with the AbsoulouteCare® system. The tailored programming precisely controls the movement and temperature of the drying drum, so silks keep their shape and wrinkles are reduced.



8000 Series
with AbsoluteCare® and SensiDry®

T8DEC846R

TECHNOLOGY



AbsoluteCare®

Our unique AbsoluteCare® system precisely controls the movement and temperature of the drying drum. Woollens are kept flat against the drum to replicate flat drying. Outdoor garments are given just the right amount of heat to restore the full functionality of their waterproof membrane. Every fabric gets the right movement and temperature to dry it completely, while preserving its quality, look and feel.



SensiDry®

SensiDry® technology reduces the drying temperature by almost half (compared to a condenser washer dryer) – reducing damage and wear, and maintaining the texture of your fabrics.



ProSense®

Automatically adjusts the time, water and energy consumption to suit any load size.



AbsoluteCare®



SensiDry®



ProSense®

SPECIFICATIONS

Drum: 8kg

Energy rating: A++

PROGRAMMES

Cotton Eco	Silk
Cottons	Bed Linen
Synthetics	Easy Iron
Mixed	Outdoor
Wool	Duvet

Additional Features

Refresh	Delay start
Anti-crease	Time drying
Dryness level	Start/Pause
Quiet mode	Child lock

Colour: Stainless steel fascia panel

Appliance Dimensions (HxWxD) in mm: 850 x 600 x 665



7000 Series
with SensiDry® and ProSense®

T7DEE845R

TECHNOLOGY



SensiDry®



ProSense®

SPECIFICATIONS

Drum: 8kg

Energy rating: A++

PROGRAMMES

Cotton Eco	Silk
Cottons	Easy Iron
Synthetics	Bed Linen
Mixed	Duvet
Wool	Sport

Additional Features

Anti-crease	Start/Pause
Dryness level	Child lock
Delay start	Refresh
Time drying	

Colour: Silver fascia panel

Appliance Dimensions (HxWxD) in mm: 850 x 600 x 665



6000 Series
with ProSense®

T6DBG821N

TECHNOLOGY



ProSense®

SPECIFICATIONS

Drum: 8kg

Energy rating: B

PROGRAMMES

Cotton Eco	Easy Iron
Cottons	Bed Linen
Synthetics	Duvet
Mixed	Jeans
Delicates	Sports

Additional Features

Anti-crease	Start/Pause
Dryness level	
Delay start	
Time drying	

Colour: White fascia panel

Appliance Dimensions (HxWxD) in mm: 850 x 596 x 626

FREESTANDING RANGE

WASHER DRYERS

With the same performance and technologies as two separate machines, you can wash and dry in one go.

We offer complete care for your woollens throughout the wash and dry cycle.



7000 Series, 9/6kg with DualSense®

L7WEE965R

TECHNOLOGY



DualSense®



ProSteam®



ProSense®

SPECIFICATIONS

Drum: 9/6kg

Energy rating: C / E

Speed: 1600rpm

Noise rating: B

PROGRAMMES

Eco 40-60

Outdoor

Cottons

Anti Allergy

Synthetics

Non Stop 60min

Delicates

Steam

Wool/Handwash

Rinse

Additional Features

Quick wash

Stains/Prewash

Delayed start

Mode

Start/Pause

Autodry

Temperature selection

Drying time

Spin selection

Colour: Silver fascia panel

Appliance Dimensions (HxWxD) in mm: 850 x 600 x 660



DualSense®

DualSense® technology tailors the temperature and motion of the drum to different fabrics. Everything from textured jackets to soft jumpers can be carefully washed, dried and cared for in one go.



7000 Series, 7/4kg
with DualSense®

L7WBG751R

TECHNOLOGY



DualSense®



ProSteam®



ProSense®

SPECIFICATIONS

Drum: 7/4kg

Energy rating: C / E

Speed: 1400rpm

Noise rating: B

PROGRAMMES

Eco 40-60	Outdoor
Cottons	Non Stop 60min
Synthetics	Steam
Delicates	Rinse
Wool/Handwash	Spin/Drain

Additional Features

Quick wash	Stains/Prewash
Delayed start	Mode
Start/Pause	Autodry
Temperature selection	Drying time
Spin selection	

Colour: White fascia panel

Appliance Dimensions (HxWxD) in mm: 850 x 600 x 576

SMALL APPLIANCES & ACCESSORIES RANGE

Welcome to the Small Appliances and Accessories range. Each product has been specially designed to harness the power of AEG technology, bringing out the best in any ingredient so you can create great tasting dishes.

IN THIS SECTION

SMALL APPLIANCES

Gourmet 7 Kettle

Gourmet 7 Toaster

HOB ACCESSORIES

Plancha Grill

Salt Block

Fusion Wok

Non-stick Frying Pan Set

Cookware Set

OVEN ACCESSORIES

Bakery Tray

Steam Set

Large Steam Tray Set

SousVide Bags

Pizza Set

REFRIGERATOR ACCESSORIES

SpinView Shelf

Extendable Shelf



GOURMET 7 KETTLE | K7-1-6BP-U

EXACT RESULTS

With precision temperature control from 40°C to 100°C, you can prepare water at the perfect heat.



Master precise temperatures required for enjoying different drinks and dishes.

Whether it's water for baking or baby food at 40°C, green tea at 80°C, or coffee at 95°C, the kettle will automatically stop heating upon reaching your pre-selected temperature.

Dimensions 23.2cm x 22.2cm x 26.1cm

GOURMET 7 TOASTER | T7-1-6BP-U

GOLDEN PRECISION

Choose from seven settings
to create the ideal results.



Different kinds of breads require different
warming settings.

Choose from seven browning options, for soft
brioches or tougher bakes like ciabatta. Toasted
to precision, customised with the twist of a dial.

Dimensions 31.5cm x 18.4cm x 20.1cm

PLANCHA GRILL | A9HL33

INDOOR BARBECUE

Instantly turn your hob into a barbecue and get perfect outdoor grill taste all year round with the Plancha Grill.



Heat is distributed quickly and evenly across the plate, ensuring all ingredients are grilled to perfection no matter where you place them.

The non-stick coating reduces the need for oil, giving you healthier dishes without compromising on taste or texture.

Works perfectly with your induction hob and can be used on all other hob types too.

Dimensions 22cm × 43.2cm × 1.8cm

SALT BLOCK | A2SLT

HIMALAYAN SALT BLOCK

The Salt Block provides a platform for seasoning and serving food naturally and healthily.



Sourced from pink rock salt in the Himalayas, the block can be heated in the oven, on the hob, or chilled in the fridge or freezer.

Dimensions 8cm x 33cm x 22cm



FUSION WOK | FUSION-WOK

STIR-FRY IN A FLASH

Get fresh flavours fast with the Fusion Wok.



Simmer and stir-fry with all the advantages of wok cooking but with the speed, energy-efficiency and temperature control of modern induction technology.

The support ring enables the same ergonomic movements as with a rounded wok and is ideal for serving too.

Suitable for induction hobs only.
Includes support ring.

Diameter 34cm

NON-STICK FRYING PAN SET | A9ALFPS1

EVERYDAY FUNCTIONALITY

Combine functionality and performance
in everyday cooking.



This set of aluminium-coated, champagne coloured frying pans are ideal for everyday frying, searing and browning with little or no oil.

Each pan has a non-stick coating and delivers fast and even cooking whilst keeping food tender and moist.

DUPONT certified non-stick coating.
Suitable for all hob types. Oven safe up to 250°C.

Diameter 26cm and 30cm

COOKWARE SET | A3SS

COOKING MASTERED

Three-piece stainless steel cookware set to master everyday cooking.



Can be used on any heat source.

The non-stick coating on the frying pan makes it easy to cook and easy to clean.

Includes: 24 cm non-stick frying pan, 16 cm pot + lid, 20 cm pot + lid.

BAKERY TRAY | A90ZBT0M

BAKING MASTERED

Enjoy freshly baked goods
with a perfect golden crust.



Perforations in the tray helps the heat and steam to circulate around the dough to create a crispy texture while keeping the interior soft and tender.

The non-stick aluminium tray makes it easy to clean. Designed to be used with AEG steam ovens.

Dimensions 46.6cm × 38.5cm

STEAM SET | A9OZS10M

PROFESSIONAL PERFORMANCE

Take your steam cooking performance to the next level with the same tools used by professional chefs.



Small perforations in the containers allow steam to circulate around the food, locking in flavour and giving even cooking results.

This high quality set comes in a full range of sizes to match all types of ingredients, from fish and meat, to rice and vegetables.

Includes 8 pieces. Stainless steel. Designed to be used with AEG steam ovens. Dishwasher safe.

LARGE STEAM TRAY SET | A9OBGC23M

ENHANCED FLAVOUR

Designed for larger quantities of food to enhance the flavour of the ingredients.



Small perforations in the containers allow steam to circulate around the food, locking in flavour and giving even cooking results.

Suitable for fish, meat, rice and vegetables.

Includes 2 stainless steel trays. Designed to be used with AEG steam ovens. Dishwasher safe.

Dimensions 32.5cm × 34.4cm

SOUSVIDE BAGS | A3OS1M

RESTAURANT QUALITY RESULTS

Now you can use the SousVide technique to get restaurant quality results at home.



SousVide maximises all the flavours to their fullest. Just vacuum seal your chosen ingredients and the chemistry between natural flavours and nutrients will expand to create great tasting, succulent dishes.

Suitable for professional and home use. Can be used up to 120°C for cooking or down to -40°C for preservation. To be used together with AEG steam ovens with the SousVide programme.

**Contains 25 bags 30cm x 20cm and
25 bags 35cm x 25cm**

PIZZA SET | A9OZPS1

PERFECTLY AUTHENTIC

Create the perfect pizza with this authentic baking technique.

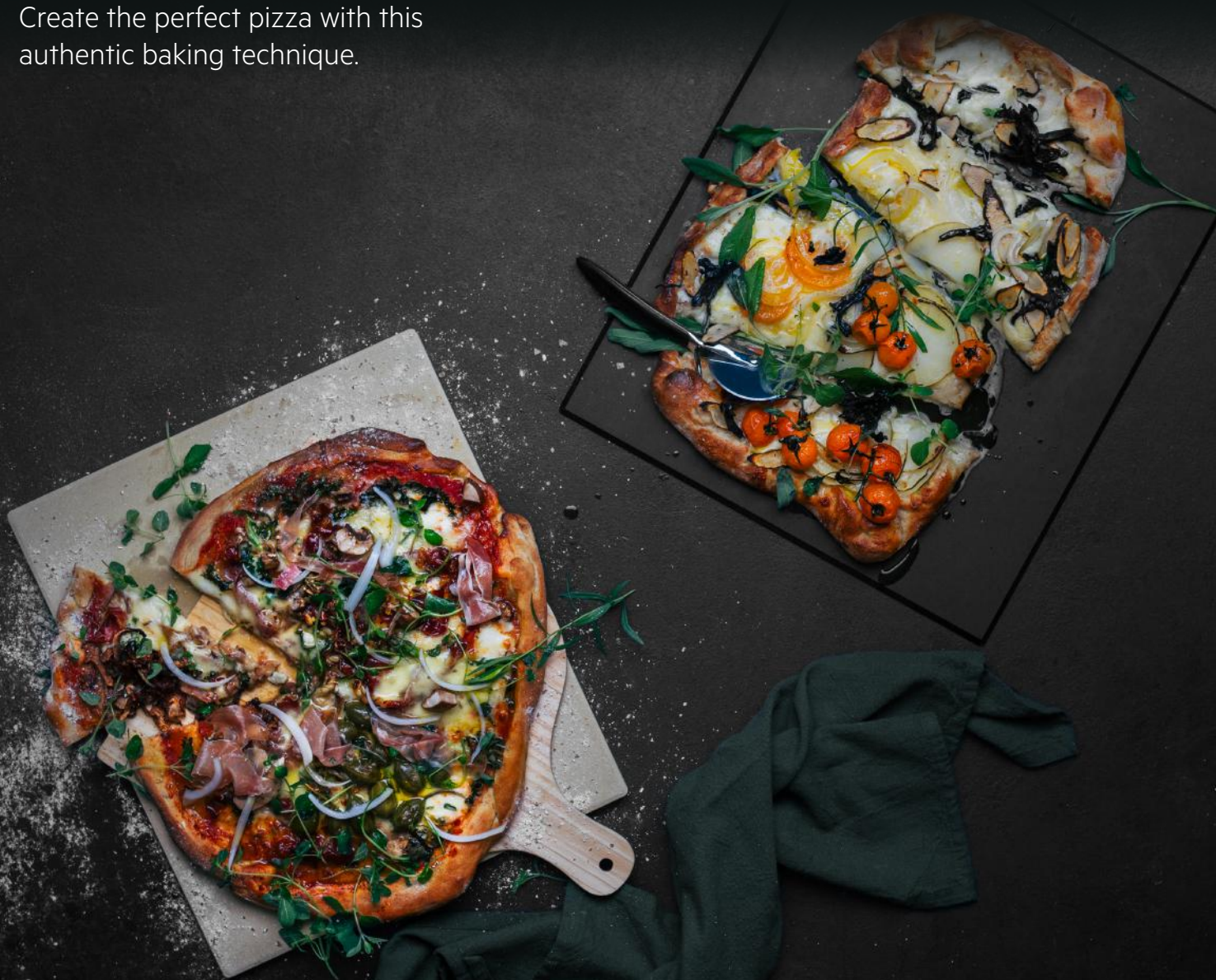

The refractory brick heats up quickly and retains the temperature, giving you the same crispy touch only a professional pizza oven can provide.

Perfect baking results also for focaccia, pastries and other breads.

Can be used for all oven types. Includes 1 stone, 1 wooden sliding board & slicer.

**Dimensions: stone 33cm x 38cm
wooden slide 29cm**

SPINVIEW SHELF | A6RHSW31

REVOLUTIONARY STORAGE

The SpinView shelf puts everything from your refrigerator within immediate reach.



No searching. No rearranging. With a revolutionary design and flexible storage, the unique 360° shelf rotates in any direction making it easier to reach your ingredients, even from the top shelf.

Fits all AEG integrated fridge freezers and fridges.

Dimensions 5.2cm x 42.3cm x 29.5cm

EXTENDABLE SHELF | A6RHES31

DESIGN AND CUSTOMISE

The Extendable Shelf Tray makes it even easier to access your refrigerated ingredients.



The extendable shelf with removable tray can be transported for use outside the fridge, making it easier to load and unload ingredients from your refrigerator.

Fits all AEG integrated fridge freezers and fridges.

Dimensions 8.5cm x 45.5cm x 30.5cm

SPECIFICATION TABLES

IN THIS SECTION

Refrigeration

Integrated Fridge Freezers

Integrated Fridges and Freezers

Freestanding Fridge Freezers

Wine Cooling

Cooking

Single Ovens

Built-In Double Ovens

Built-Under Double Oven

Compacts

Microwave Ovens

Hobs

Hoods

Dishwashers

Fully Integrated Dishwashers

Slimline Fully Integrated Dishwasher

Laundry

Built-in Washing Machine

Built-in Washer Dryer

Freestanding Washing Machines

Freestanding Tumble Dryers

Freestanding Washer Dryers





AEG

5°C



REFRIGERATION



RCB732E4MG



SCE818C5TC



SCE818E5TC



SCE819E5TS

Overview

TwinTech®	•	•	•	•
NoFrost	•	•	•	•
LowFrost				
CustomFlex®		•	•	
LongFresh				
Soft Close Doors		•	•	
Multi Airflow Cooling	•			
DynamicAir Technology	•	•		•
LCD Touch Display/Electronic Controls/ Mechanical Temperature Control	Electronic Touch	Electronic Touch	Electronic Touch	Simple Touch
LED Lighting	•	•	•	•
Coolmatic	•	•	•	•
Frostmatic	•	•	•	•
Holiday Mode		•	•	•
High Temperature Alarm		•	•	•
Door Open Alarm	•	•	•	
Door Opening	Right	Right & Reversible	Right & Reversible	Right & Reversible
Gross Capacity (ltr/cu.ft)	341	265	265	287
Net Capacity (ltr/cu.ft)	302	247	247	267
Fridge Features				
Gross Capacity Fridge (ltr/cu.ft)	215	189	189	211
Net Capacity Fridge (ltr/cu.ft)	208	186	186	207
Defrost – Fridge	Auto	Auto	Auto	Auto
Glass Shelves	2	3	3	3
Flexi Shelf (Half Depth)		•	•	•
Fresh Box	•			•
Bottle Rack				
Large Telescopic Pull Out Salad Drawer	•			
Large Salad Drawer	•			
2 Extra Deep 1/2 Width Salad Drawers		2 Half Width	2 Half Width	
Full Width Recessed Salad Drawer with 2 Glass Lids				
Dairy Compartment with Lid		•	•	•
No. Full Width Door Shelves				
1/2 Width Sliding Door Shelf				•
Egg Tray	2 for 8 eggs	2 for 6 eggs	2 for 6 eggs	2 for 6 eggs
Freezer Features				
Gross Capacity Freezer (ltr/cu.ft)	104	76	76	76
Net Capacity Freezer (ltr/cu.ft)	94	61	61	60
Defrost – Freezer	Auto	Auto	Auto	Auto
No. Full Width Drawers	2 Full, 1 Half	3 Full Width	3 Full Width	3 Full Width
Telescopic Freezer Drawers				
Product Dimensions				
Height (mm)	1860	1769	1769	1884
Width (mm)	595	556	556	540
Depth (mm)	662	549	549	549
Built-in Dimensions				
Built-in Height (mm)	1860	1769	1769	1898
Built-in Width (mm)	595	556	556	556
Built-In Depth (mm)	662	549	549	549
Door Fixing	FS	BI DoD	BI DoD	BI Slide Door
Performance				
Annual Energy Consumption	263	120	226	233
Energy Efficiency Class	E	C	E	E
Climate Class	SN-N-ST-T	SN-N-ST-T	SN-N-ST-T	SN-N-ST-T
Noise	42	39	39	39
Freezing Capacity	8	10	10	10
Power Cut Safe Rising Time	18	23	23	21
Minimum Ambient Temperature	10	10	10	10



SCE819E7TS



SCE818E8TS



SCE818E6TC



SCE818E6NS

Overview

TwinTech®	•	•	•	•
NoFrost	•	•	•	•
LowFrost				
CustomFlex®		•		
LongFresh				
Soft Close Doors		•		•
Multi Airflow Cooling				
DynamicAir Technology	•			
LCD Touch Display/Electronic Controls/ Mechanical Temperature Control	Electronic Touch	Electronic Touch	Electronic Touch	Electronic Touch
LED Lighting	•	•	•	•
Coolmatic	•	•	•	•
Frostmatic	•	•	•	•
Holiday Mode	•	•	•	•
High Temperature Alarm	•	•	•	•
Door Open Alarm				
Door Opening	Right & Reversible	Right & Reversible	Right & Reversible	Right & Reversible
Gross Capacity (ltr/cu.ft)	287	273	265	264
Net Capacity (ltr/cu.ft)	267	253	247	239
Fridge Features				
Gross Capacity Fridge (ltr/cu.ft)	211	197	189	157
Net Capacity Fridge (ltr/cu.ft)	207	192	186	152
Defrost – Fridge	Auto	Auto	Auto	Auto
Glass Shelves	3	3	3	2
Flexi Shelf (Half Depth)	•	•	•	•
Fresh Box	•			
Bottle Rack				
Large Telescopic Pull Out Salad Drawer				
Large Salad Drawer		GreenZone		
2 Extra Deep 1/2 Width Salad Drawers			2 Half Width	2 Half Width
Full Width Recessed Salad Drawer with 2 Glass Lids		GreenZone		
Dairy Compartment with Lid	•	•	•	•
No. Full Width Door Shelves				
1/2 Width Sliding Door Shelf	•		•	•
Egg Tray	1 for 10 eggs	2 for 6 eggs	2 for 6 eggs	2 for 6 eggs
Freezer Features				
Gross Capacity Freezer (ltr/cu.ft)	76	76	76	107
Net Capacity Freezer (ltr/cu.ft)	60	61	61	87
Defrost – Freezer	Auto	Auto	Auto	Auto
No. Full Width Drawers	3 Full Width	3 Full Width	3 Full Width	4 Full Width
Telescopic Freezer Drawers				
Product Dimensions				
Height (mm)	1884	1772	1769	1772
Width (mm)	540	540	556	540
Depth (mm)	549	549	549	549
Built-in Dimensions				
Built-in Height (mm)	1898	1772	1769	1772
Built-in Width (mm)	556	540	556	540
Built-In Depth (mm)	549	549	549	549
Door Fixing	BI Slide Door	BI Slide Door	BI DoD	BI Slide Door
Performance				
Annual Energy Consumption	233	228	226	238
Energy Efficiency Class	E	E	E	E
Climate Class	SN-N-ST-T	SN-N-ST-T	SN-N-ST-T	SN-N-ST-T
Noise	39	39	39	39
Freezing Capacity	10	10	10	10
Power Cut Safe Rising Time	21	21	23	25
Minimum Ambient Temperature	10	10	10	10

REFRIGERATION



SCE818F6NS



SCE818F6TS



SCB618F3LS



SCB718F3LS

Overview

TwinTech®	•	•		
NoFrost	•	•		
LowFrost			•	•
CustomFlex®				
LongFresh				
Soft Close Doors				
Multi Airflow Cooling				
DynamicAir Technology		•		
LCD Touch Display/Electronic Controls/ Mechanical Temperature Control	Electronic Touch	Electronic Touch	Simple Touch	Simple Touch
LED Lighting	•	•	•	•
Coolmatic	•	•		
Frostmatic	•	•	•	•
Holiday Mode	•	•		
High Temperature Alarm	•	•		
Door Open Alarm	•	•		
Door Opening	Right & Reversible	Right & Reversible	Right & Reversible	Right & Reversible
Gross Capacity (ltr/cu.ft)	264	273	272	269
Net Capacity (ltr/cu.ft)	239	253	268	266
Fridge Features				
Gross Capacity Fridge (ltr/cu.ft)	157	197	199	163
Net Capacity Fridge (ltr/cu.ft)	152	192	196	160
Defrost – Fridge	Auto	Auto	Auto	Auto
Glass Shelves	2	3	4	3
Flexi Shelf (Half Depth)	•	•		
Fresh Box				
Bottle Rack				
Large Telescopic Pull Out Salad Drawer				
Large Salad Drawer				
2 Extra Deep 1/2 Width Salad Drawers	2 Half Width	2 Half Width	2 Half Width	2 Half Width
Full Width Recessed Salad Drawer with 2 Glass Lids				
Dairy Compartment with Lid	•	•	•	•
No. Full Width Door Shelves				
1/2 Width Sliding Door Shelf	•	•		•
Egg Tray	2 for 6 eggs	2 for 6 eggs	2 for 6 eggs	2 for 6 eggs
Freezer Features				
Gross Capacity Freezer (ltr/cu.ft)	107	76	73	106
Net Capacity Freezer (ltr/cu.ft)	87	61	72	106
Defrost – Freezer	Auto	Auto	Manual	Manual
No. Full Width Drawers	4 Full Width	3 Full Width	3 Full Width	4 Full Width
Telescopic Freezer Drawers				
Product Dimensions				
Height (mm)	1772	1772	1772	1772
Width (mm)	540	540	540	540
Depth (mm)	549	549	549	549
Built-in Dimensions				
Built-in Height (mm)	1772	1772	1772	1772
Built-in Width (mm)	540	540	540	540
Built-In Depth (mm)	549	549	549	549
Door Fixing	BI Slide Door	BI Slide Door	BI Slide Door	BI Slide Door
Performance				
Annual Energy Consumption	303	291	291	293
Energy Efficiency Class	F	F	F	F
Climate Class	SN-N-ST-T	SN-N-ST-T	SN-N-ST-T	SN-N-ST
Noise	39	40	36	36
Freezing Capacity	10	10	4	4
Power Cut Safe Rising Time	24	21	22	22
Minimum Ambient Temperature	10	10	10	10



SCB614F1LS



ABE682F1NF



ABB682F1NF



SFB682F1AF

Overview

TwinTech®				
NoFrost		•		
LowFrost	•			
CustomFlex®				
LongFresh				
Soft Close Doors				
Multi Airflow Cooling				
DynamicAir Technology				
LCD Touch Display/Electronic Controls/ Mechanical Temperature Control	Mechanical Control	Electronic	Electronic	Mechanical
LED Lighting	•			•
Coolmatic				
Frostmatic		•	•	
Holiday Mode				
High Temperature Alarm		•	•	
Door Open Alarm		•	•	
Door Opening	Right & Reversible	Right & Reversible	Right & Reversible	Right & Reversible
Gross Capacity (ltr/cu.ft)	220	86	105	111
Net Capacity (ltr/cu.ft)	217	85	95	109
Fridge Features				
Gross Capacity Fridge (ltr/cu.ft)	163			111
Net Capacity Fridge (ltr/cu.ft)	160			109
Defrost – Fridge	Auto			Auto
Glass Shelves	3			2
Flexi Shelf (Half Depth)				
Fresh Box				
Bottle Rack				
Large Telescopic Pull Out Salad Drawer				
Large Salad Drawer				1 Full Width
2 Extra Deep 1/2 Width Salad Drawers	2 Half Width			
Full Width Recessed Salad Drawer with 2 Glass Lids				
Dairy Compartment with Lid	•			•
No. Full Width Door Shelves				
1/2 Width Sliding Door Shelf	•			•
Egg Tray	2 for 6 eggs			1 for 6 eggs
Freezer Features				
Gross Capacity Freezer (ltr/cu.ft)	57	86	105	
Net Capacity Freezer (ltr/cu.ft)	57	85	95	
Defrost – Freezer	Manual	Auto	Manual	
No. Full Width Drawers	2 Full Width	3 Full Width	3 Full Width	
Telescopic Freezer Drawers		•		
Product Dimensions				
Height (mm)	1441	815	815	815
Width (mm)	540	596	596	596
Depth (mm)	549	550	550	550
Built-in Dimensions				
Built-in Height (mm)	1441	815	815	815
Built-in Width (mm)	540	596	596	596
Built-In Depth (mm)	549	550	550	550
Door Fixing	BI Slide Door	BI UC DoD	BI UC DoD	BI UC DoD
Performance				
Annual Energy Consumption	204	191	187	172
Energy Efficiency Class	F	F	F	F
Climate Class	SN-N-ST-T	SN-N-ST-T	SN-N-ST-T	SN-N-ST
Noise	35	42	38	38
Freezing Capacity	4	12	18	2.5
Power Cut Safe Rising Time	20	13	21	11
Minimum Ambient Temperature	10	10	10	10

REFRIGERATION



SKB582F1AF



ABK818E6NC



ABB812E6NC



SKK818E9ZC

Overview

TwinTech®				
NoFrost		•	•	
LowFrost				
CustomFlex®				
LongFresh				•
Soft Close Doors		•	•	•
Multi Airflow Cooling				
DynamicAir Technology				
LCD Touch Display/Electronic Controls/ Mechanical Temperature Control	Mechanical	Electronic Touch	Electronic Touch	Electronic Touch
LED Lighting	•			•
Coolmatic				•
Frostmatic		•	•	
Holiday Mode				
High Temperature Alarm		•	•	•
Door Open Alarm		•	•	•
Door Opening	Right & Reversible	Right & Reversible	Right & Reversible	Right & Reversible
Gross Capacity (ltr/cu.ft)	136	216	130	298
Net Capacity (ltr/cu.ft)	133	204	120	275
Fridge Features				
Gross Capacity Fridge (ltr/cu.ft)	136			298
Net Capacity Fridge (ltr/cu.ft)	133			275
Defrost – Fridge	Auto			Auto
Glass Shelves	3			3
Flexi Shelf (Half Depth)				•
Fresh Box				
Bottle Rack				
Large Telescopic Pull Out Salad Drawer				
Large Salad Drawer	1 Full Width			
2 Extra Deep 1/2 Width Salad Drawers				
Full Width Recessed Salad Drawer with 2 Glass Lids				
Dairy Compartment with Lid	•			•
No. Full Width Door Shelves				
1/2 Width Sliding Door Shelf	•			•
Egg Tray	1 for 6 eggs			2 for 6 eggs
Freezer Features				
Gross Capacity Freezer (ltr/cu.ft)		216	130	
Net Capacity Freezer (ltr/cu.ft)		204	120	
Defrost – Freezer		Auto	Auto	
No. Full Width Drawers		5 Full Width	4 Full Width	
Telescopic Freezer Drawers				•
Product Dimensions				
Height (mm)	815	1769	1224	1769
Width (mm)	596	556	556	556
Depth (mm)	550	549	549	549
Built-in Dimensions				
Built-in Height (mm)	815	1769	1224	1769
Built-in Width (mm)	596	556	556	556
Built-In Depth (mm)	550	549	549	549
Door Fixing	BI UC DoD	BI DoD	BI DoD	BI DoD
Performance				
Annual Energy Consumption	118	238	183	130
Energy Efficiency Class	F	E	E	E
Climate Class	SN-N-ST-T	SN-N-ST-T	SN-N-ST-T	SN-N-ST-T
Noise	37	39	39	37
Freezing Capacity		20	20	
Power Cut Safe Rising Time		24	22	
Minimum Ambient Temperature	10	10	10	10



SKE818E1DC



SKB812F1AC

Overview

TwinTech®		
NoFrost		
LowFrost		
CustomFlex®		
LongFresh		
Soft Close Doors		•
Multi Airflow Cooling	•	
DynamicAir Technology		
LCD Touch Display/Electronic Controls/ Mechanical Temperature Control	Electronic Touch	
LED Lighting	•	•
Coolmatic	•	•
Frostmatic		
Holiday Mode	•	•
High Temperature Alarm		
Door Open Alarm	•	•
Door Opening	Right & Reversible	Right & Reversible
Gross Capacity (ltr/cu.ft)	314	205
Net Capacity (ltr/cu.ft)	310	202
Fridge Features		
Gross Capacity Fridge (ltr/cu.ft)	314	205
Net Capacity Fridge (ltr/cu.ft)	310	202
Defrost – Fridge	Auto	Auto
Glass Shelves	4	3
Flexi Shelf (Half Depth)	•	•
Fresh Box	•	
Bottle Rack		
Large Telescopic Pull Out Salad Drawer		
Large Salad Drawer		
2 Extra Deep 1/2 Width Salad Drawers		2 Half Width
Full Width Recessed Salad Drawer with 2 Glass Lids		
Dairy Compartment with Lid	•	•
No. Full Width Door Shelves		
1/2 Width Sliding Door Shelf	•	•
Egg Tray	2 for 6 eggs	2 for 6 eggs
Freezer Features		
Gross Capacity Freezer (ltr/cu.ft)		
Net Capacity Freezer (ltr/cu.ft)		
Defrost – Freezer		
No. Full Width Drawers		
Telescopic Freezer Drawers	•	
Product Dimensions		
Height (mm)	1769	1219
Width (mm)	556	556
Depth (mm)	549	550
Built-in Dimensions		
Built-in Height (mm)	1769	1219
Built-in Width (mm)	556	556
Built-In Depth (mm)	549	550
Door Fixing	BI DoD	BI DoD
Performance		
Annual Energy Consumption	114	103
Energy Efficiency Class	E	E
Climate Class	SN-N-ST-T	SN-N-ST-T
Noise	35	35
Freezing Capacity		
Power Cut Safe Rising Time		
Minimum Ambient Temperature	10	10

REFRIGERATION



RMB954F9VX



RMB76121NX

Overview

TwinTech®	•	
NoFrost		•
LowFrost		
CustomFlex®		
LongFresh		
Soft Close Doors	•	
Multi Airflow Cooling		•
DynamicAir Technology		
LCD Touch Display/Electronic Controls/ Mechanical Temperature Control	Electronic Touch	LCD touch
LED Lighting	•	•
Coolmatic	•	•
Frostmatic	•	•
Holiday Mode		•
High Temperature Alarm	•	•
Door Open Alarm	•	•
Door Opening	Left & Right	Side by side
Gross Capacity (ltr/cu.ft)	680	608
Net Capacity (ltr/cu.ft)	541	549
Fridge Features		
Gross Capacity Fridge (ltr/cu.ft)	413	380
Net Capacity Fridge (ltr/cu.ft)	363	370
Defrost – Fridge	Auto	Auto
Glass Shelves	1	4
Flexi Shelf (Half Depth)	1	
Fresh Box	•	•
Bottle Rack		
Large Telescopic Pull Out Salad Drawer		
Large Salad Drawer		3 Full Width
2 Extra Deep 1/2 Width Salad Drawers	•	
Full Width Recessed Salad Drawer with 2 Glass Lids		
Dairy Compartment with Lid	•	•
No. Full Width Door Shelves		
1/2 Width Sliding Door Shelf	•	
Egg Tray	1 for 12 eggs	1 for 6 eggs
Freezer Features		
Gross Capacity Freezer (ltr/cu.ft)	267	228
Net Capacity Freezer (ltr/cu.ft)	178	179
Defrost – Freezer	Auto	Auto
No. Full Width Drawers	2 Full width	2 Full width
Telescopic Freezer Drawers		
Product Dimensions		
Height (mm)	1782	1860
Width (mm)	913	1190
Depth (mm)	746	623
Built-in Dimensions		
Built-in Height (mm)	1782	1860
Built-in Width (mm)	913	1190
Built-In Depth (mm)	746	623
Door Fixing	FS	FS
Performance		
Annual Energy Consumption	448	467
Energy Efficiency Class	F	F
Climate Class	SN-N-ST-T	SN-N-ST-T
Noise	42	43
Freezing Capacity	10	16
Power Cut Safe Rising Time	14	10
Minimum Ambient Temperature	10	10



AWUS052B5B



AWUS020B5B



KWK884520T



KWK884520M

Overview

TwinTech®				
NoFrost				
LowFrost				
CustomFlex®				
LongFresh				
Soft Close Doors				
Multi Airflow Cooling				
DynamicAir Technology				
LCD Touch Display/Electronic Controls/ Mechanical Temperature Control	Electronic	Electronic	Electronic	Electronic
LED Lighting	•	•	•	•
Coolmatic				
Frostmatic				
Holiday Mode				
High Temperature Alarm				
Door Open Alarm				
Door Opening	Right & Reversible	Right & Reversible	Drop down	Drop down
Gross Capacity (l/cu.ft)				
Net Capacity (l/cu.ft)				
Capacity	46 Bottles	18 Bottles	18 Bottles	18 Bottles
Fridge Features				
Gross Capacity Fridge (l/cu.ft)	145	58	52	52
Net Capacity Fridge (l/cu.ft)	138	56	49	49
Defrost – Fridge				
Glass Shelves	6	6	2	2
Flexi Shelf (Half Depth)				
Fresh Box				
Bottle Rack				
Large Telescopic Pull Out Salad Drawer				
Large Salad Drawer				
2 Extra Deep 1/2 Width Salad Drawers				
Full Width Recessed Salad Drawer with 2 Glass Lids				
Dairy Compartment with Lid				
No. Full Width Door Shelves				
1/2 Width Sliding Door Shelf				
Egg Tray				
Freezer Features				
Gross Capacity Freezer (l/cu.ft)				
Net Capacity Freezer (l/cu.ft)				
Defrost – Freezer				
No. Full Width Drawers				
Telescopic Freezer Drawers				
Product Dimensions				
Height (mm)	820	820	455	455
Width (mm)	595	294	595	595
Depth (mm)	565	571	566	566
Built-in Dimensions				
Built-in Height (mm)	820	820	450	450
Built-in Width (mm)	595	294	560	560
Built-In Depth (mm)	565	571	550	550
Door Fixing	BI Wide Door	BI Wide Door	BI Drop Down	BI Drop Down
Performance				
Annual Energy Consumption	149	140	83	83
Energy Efficiency Class	G	G	F	F
Climate Class	N-ST	N-ST	ST	ST
Noise	39	41	39	39
Freezing Capacity				
Power Cut Safe Rising Time				
Minimum Ambient Temperature	16	16	16	16

SINGLE OVENS



BSK999330T



BSK999330M



BSK798380M



BSK792380B

Oven Features

	Command Wheel	Command Wheel	Touch	Touch
Control Type	Command Wheel	Command Wheel	Touch	Touch
Connected Appliance	Yes	Yes		
Integrated Oven Camera	Yes	Yes		
Menu Guided Cooking	Yes	Yes	Yes	Yes
Oven Capacity (Usable)	70	70	70	70
Number of Functions	25	25	25	25
Fast Heat Up	Yes	Yes	Yes	Yes
SoftMotion™ Soft Close Door	Yes	Yes	Yes	Yes
Fully Programmable Timer	Yes	Yes	Yes	Yes
Core Temperature Sensor	Yes	Yes	Yes	Yes
FloodLight™	Yes	Yes	Yes	Yes
Sidelight	Yes	Yes	Yes	Yes
Cleaning	Steam	Steam	Steam	Steam
Oven Door Glazing	Four	Four	Four	Four
Cooling Fan	Yes	Yes	Yes	Yes
Steam	Yes & Steamify®	Yes & Steamify®	Yes & Steamify®	Yes & Steamify®

Accessories

Number of Shelves	Two	Two	Two	Two
Telescopic Runners	Yes	Yes	Yes	Yes
MaxiTray™				
Full Width Grill/Meat Pan (with Trivet)	Yes	Yes	Yes	Yes
Perforated Baking Trays	Yes	Yes	Yes	Yes
Patisserie Tray	Yes	Yes	Yes	Yes

Dimensions

Appliance Dimensions				
Height (mm)	594	594	594	594
Width (mm)	595	595	595	595
Depth (mm)	567	567	567	567
Aperture Dimensions				
Height (mm)	590	590	590	590
Width (mm)	560	560	560	560
Depth (mm)	550	550	550	550

Performance

Oven Temperature Range (°C)	30°C–230°C	30°C–230°C	30°C–230°C	30°C–230°C
Energy Efficiency Class	A++	A++	A++	A++
Energy Efficiency Class in Mode Static/Fan	Fan	Fan	Fan	Fan
Energy Consumption Fan (kWh)	0.52	0.52	0.52	0.52
Energy Consumption Static (kWh)	0.99	0.99	0.99	0.99
Largest Baking Sheet Surface Area	1424	1424	1424	1424
Connected Load (W)	3500	3500	3500	3500
Fuse Rating (A)	16	16	16	16



BSK782320M



BSK978330M



BSK774320M

Oven Features

Control Type	Touch	Command Wheel	Touch
Connected Appliance		Yes	
Integrated Oven Camera			
Menu Guided Cooking	Yes	Yes	Yes
Oven Capacity (Usable)	70	71	71
Number of Functions	17	19	18
Fast Heat Up	Yes	Yes	Yes
SoftMotion™ Soft Close Door	Yes	Yes	Yes
Fully Programmable Timer	Yes	Yes	Yes
Core Temperature Sensor	Yes	Yes	Yes
FloodLight™	Yes	Yes	Yes
SideLight	Yes	Yes	Yes
Cleaning	Steam	Pyrolytic	Pyrolytic
Oven Door Glazing	Three	Four	Four
Cooling Fan	Yes	Yes	Yes
Steam	Yes	Yes	Yes

Accessories

Number of Shelves	Two	Two	Two
Telescopic Runners		Yes	Yes
MaxiTray™	Yes		Yes
Full Width Grill/Meat Pan (with Trivet)	Yes	Yes	Yes
Perforated Baking Trays	Yes		
Patisserie Tray			

Dimensions

Appliance Dimensions			
Height (mm)	594	594	594
Width (mm)	595	595	595
Depth (mm)	567	567	567
Aperture Dimensions			
Height (mm)	590	590	590
Width (mm)	560	560	560
Depth (mm)	550	550	550

Performance

Oven Temperature Range (°C)	30°C–230°C	30°C–300°C	30°C–300°C
Energy Efficiency Class	A+	A++	A+
Energy Efficiency Class in Mode Static/Fan	Fan	Fan	Fan
Energy Consumption Fan (kWh)	0.68	0.52	0.69
Energy Consumption Static (kWh)	0.99	1.09	0.99
Largest Baking Sheet Surface Area	1424	1424	1424
Connected Load (W)	3500	3500	3500
Fuse Rating (A)	16	16	16

SINGLE OVENS



BPK948330T



BPK948330M



BPK748380M



BPK748380B

Oven Features

Control Type	Command Wheel	Command Wheel	Touch	Touch
Connected Appliance	Yes	Yes		
Integrated Oven Camera				
Menu Guided Cooking	Yes	Yes	Yes	Yes
Oven Capacity (Usable)	71	71	71	71
Number of Functions	17	17	16	16
Fast Heat Up	Yes	Yes	Yes	Yes
SoftMotion™ Soft Close Door	Yes	Yes	Yes	Yes
Fully Programmable Timer	Yes	Yes	Yes	Yes
Core Temperature Sensor	Yes	Yes	Yes	Yes
FloodLight™	Yes	Yes	Yes	Yes
SideLight™	Yes	Yes	Yes	Yes
Cleaning	Pyrolytic	Pyrolytic	Pyrolytic	Pyrolytic
Oven Door Glazing	Four	Four	Four	Four
Cooling Fan	Yes	Yes	Yes	Yes
Steam				

Accessories

Number of Shelves	Two	Two	Two	Two
Telescopic Runners	Yes	Yes	Yes	Yes
MaxiTray™				
Full Width Grill/Meat Pan (with Trivet)	Yes	Yes	Yes	Yes
Perforated Baking Trays				
Patisserie Tray				

Dimensions

Appliance Dimensions				
Height (mm)	594	594	594	594
Width (mm)	595	595	595	595
Depth (mm)	567	567	567	567
Aperture Dimensions				
Height (mm)	590	590	590	590
Width (mm)	560	560	560	560
Depth (mm)	550	550	550	550

Performance

Oven Temperature Range (°C)	30°C–300°C	30°C–300°C	30°C–300°C	30°C–300°C
Energy Efficiency Class	A++	A++	A++	A++
Energy Efficiency Class in Mode Static/Fan	Fan	Fan	Fan	Fan
Energy Consumption Fan (kWh)	0.52	0.52	0.52	0.52
Energy Consumption Static (kWh)	1.09	1.09	1.09	1.09
Largest Baking Sheet Surface Area	1424	1424	1424	1424
Connected Load (W)	3500	3500	3500	3500
Fuse Rating (A)	16	16	16	16



BPK744L21M/R21M



BPK55632PM



BPK355020M



BCK55632XM

Oven Features

	Touch	Retractable + Touch	Retractable + Touch	Retractable + Touch
Control Type	Touch	Retractable + Touch	Retractable + Touch	Retractable + Touch
Connected Appliance				
Integrated Oven Camera				
Menu Guided Cooking	Yes			
Oven Capacity (Usable)	71	71	71	71
Number of Functions	21	10	11	11
Fast Heat Up	Yes	Yes	Yes	
SoftMotion™ Soft Close Door		Yes		Yes
Fully Programmable Timer	Yes	Yes	Yes	Yes
Core Temperature Sensor	Yes	Yes		Yes
FloodLight™	Yes	Yes		Yes
SideLight™	Yes	Yes	Yes	Yes
Cleaning	Pyrolytic	Pyrolytic	Pyrolytic	Catalytic
Oven Door Glazing	Four	Three	Four	Three
Cooling Fan	Yes	Yes	Yes	Yes
Stream				

Accessories

Number of Shelves	Two	Two	Two	Two
Telescopic Runners		Yes		Yes
MaxiTray™	Yes	Yes		
Full Width Grill/Meat Pan (with Trivet)	Yes	Yes	Yes	Yes
Perforated Baking Trays				
Patisserie Tray				

Dimensions

Appliance Dimensions				
Height (mm)	594	594	594	594
Width (mm)	594	594	595	595
Depth (mm)	568	567	567	567
Aperture Dimensions				
Height (mm)	600	590	590	590
Width (mm)	560	560	560	560
Depth (mm)	550	550	550	550

Performance

Oven Temperature Range (°C)	30°C-300°C	30°C-300°C	30°C-300°C	30°C-300°C
Energy Efficiency Class	A+	A+	A+	A+
Energy Efficiency Class in Mode Static/Fan	Fan	Fan	Fan	Fan
Energy Consumption Fan (kWh)	0.69	0.69	0.69	0.69
Energy Consumption Static (kWh)	0.93	0.99	1.09	1.09
Largest Baking Sheet Surface Area	1424	1418	1418	1418
Connected Load (W)	3480	3200	3200	3200
Fuse Rating (A)	16	16	16	16

DOUBLE OVENS



DCK731110M



DCK431110M



DUK731110M

Oven Features

T=Top/B=Bottom			
Control Type	Touch	Retractable	Touch
Oven Capacity (Usable)	39/61	43/68	39/46
Number of Cooking Functions	8/10	6/8	8/10
Fully Programmable Timer	Yes	Yes	Yes
Cleaning	Catalytic	Catalytic	Catalytic
Oven Doors Glazing	3/3	2/2	3/3
Lights	1/1	1/1	1/1
Cooling Fan	Yes	Yes	Yes

Accessories

Number of Shelves	2/2	1/2	1/2
Full Width Grill/Meat Pan (with Trivet)	Yes/Yes	-/Yes	-/Yes

Dimensions

Appliance Dimensions			
Height (mm)	888	888	715
Width (mm)	594	594	594
Depth (mm)	548	548	548
Aperture Dimensions			
Height (mm)	875	875	870
Width (mm)	560	560	600
Depth (mm)	550	550	550

Performance

Energy Efficiency Class	A/A	A/A	A/A
Energy Efficiency Class in Mode Static/Fan	Fan/Fan	Static/Fan	Fan/Fan
Energy Consumption Fan (kWh)	0.79/0.82	N/A/0.86	0.79/0.79
Cook Time Standard Load Fan (Min)	49/49	NA/44	49/48
Energy Consumption Static (kWh)	0.89/0.89	0.78/0.86	0.85/0.75
Cook Time Standard Load Static (Min)	52/52	48/45	53/50
Largest Baking Sheet Surface Area (cm ²)	1175	1175	1175
Connected Load (W)	5800	5100	5900
Fuse Rating (A)	30	30	30

COMPACT COMBI OVENS



KMK968000T



KMK968000M



KMK768080M



KMK768080B

Oven Features

Combi Microwave, Fan Oven and Grill	Yes	Yes	Yes	Yes
Duo Microwave and Grill	Yes	Yes	Yes	Yes
Solo Microwave	Yes	Yes	Yes	Yes
Oven Volume (ltr)	43	43	43	43
Auto Cook Programmes	90	90	100	100
Control Type	Command Wheel	Command Wheel	Touch	Touch
Connected Appliance	Yes	Yes		
Electronic Clock/Programmer	Yes	Yes	Yes	Yes
Quickstart	Yes	Yes	Yes	Yes
Powersave Mode	Yes	Yes	Yes	Yes
Programme End Signal	Yes	Yes	Yes	Yes
Drop Down Door	Yes	Yes	Yes	Yes

Dimensions

Appliance Dimensions				
Height (mm)	455	455	455	455
Width (mm)	594	594	594	594
Depth (mm)	567	567	567	567
Built-in Dimensions				
Height (mm)	450	450	450	450
Width (mm)	560	560	560	560
Depth (mm)	550	550	550	550

Performance

Microwave Output (W)	1000	1000	1000	1000
Grill Output (W)	1900	1900	1900	1900
Convection Oven Output (W)	1650	1650	1650	1650
Connected Load (W)	3000	3000	3000	3000
Fuse Rating (A)	13	16	13	13



KMK565000M



KMK525800M

Oven Features

Combi Microwave, Fan Oven and Grill	Yes	
Duo Microwave and Grill	Yes	Yes
Solo Microwave	Yes	Yes
Oven Volume (ltr)	43	42
Auto Cook Programmes	45	12
Control Type	Retractable + Touch	Retractable + Touch
Electronic Clock/Programmer	Yes	Yes
Quickstart	Yes	Yes
Powersave Mode	Yes	Yes
Programme End Signal	Yes	Yes
Drop Down Door	Yes	Yes

Dimensions

Appliance Dimensions	
Height (mm)	455
Width (mm)	594
Depth (mm)	567
Built-in Dimensions	
Height (mm)	450
Width (mm)	560
Depth (mm)	550

Performance

Microwave Output (W)	1000
Grill Output (W)	1900
Convection Oven Output (W)	1650
Connected Load (W)	3000
Fuse Rating (A)	13

COFFEE MACHINES



KKK994500T

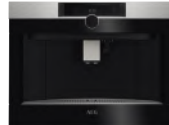

KKK994500M



KKK884500M

Features

	KKK994500T	KKK994500M	KKK884500M
Electronic Touch Controls	Command Wheel	Command Wheel	Touch
LED Display	Yes	Yes	Yes
Automatic Cappuccino Function	Yes	Yes	Yes
Pre-Programmed Coffee Selection	Yes	Yes	Yes
Water Sensor with LED when Refill Required	Yes	Yes	Yes
Steam/Water Spout with LED Indicators	Yes	Yes	Yes
Height Adjustable Coffee Dispenser	Yes	Yes	Yes
Lamp	Yes	Yes	Yes

Dimensions

Appliance Dimensions			
Height (mm)	455	455	455
Width (mm)	594	594	594
Depth (mm)	361	361	361
Built-in Dimensions			
Height (mm)	450	450	450
Width (mm)	560	560	560
Depth (mm)	550	550	550

Electrical Connection

	KKK994500T	KKK994500M	KKK884500M
Connected Load (W)	1350	1350	1350
Fuse Rating (A)	13	13	13
Working Pressure (Bar)	15	15	15

WARMING DRAWERS



KDK912924M



KDE912924M



KDK911424T



KDK911424M

Features

Place Settings	12	12	6	6
Cups And Glass Warming (40°C)	Yes	Yes	Yes	Yes
Plate Warming (60°C)	Yes	Yes	Yes	Yes
Food Warming (80°C Max)	Yes	Yes	Yes	Yes
Defrosting (30°C Max)	Yes	Yes	Yes	Yes
Heating Element	Yes	Yes	Yes	Yes
Fan Air Circulation	Yes	Yes	Yes	Yes
Rotary Control Knob	Yes	Yes	Yes	Yes
Variable Temperature Control	Yes	Yes	Yes	Yes
On/Off LED	Yes	Yes	Yes	Yes
Anti-Slip Mat	Yes	Yes	Yes	Yes
Temperature Range	30°C-80°C	30°C-80°C	30°C-80°C	30°C-80°C

Dimensions

Appliance Dimensions				
Height (mm)	295	295	131	131
Width (mm)	595	595	595	595
Depth (mm)	535	535	500	500
Built-in Dimensions				
Height (mm)	295	295	139	139
Width (mm)	560	560	560	560
Depth (mm)	550	550	550	550

Performance

Connected Load (W)	550	550	430	430
Fuse Rating (A)	13	13	13	13



KDE911424M



KDE911424B

Features

Place Settings	6	6
Cups and Glass Warming (40°C)	Yes	Yes
Plate Warming (60°C)	Yes	Yes
Food Warming (80°C Max)	Yes	Yes
Defrosting (30°C Max)	Yes	Yes
Heating Element	Yes	Yes
Fan Air Circulation	Yes	Yes
Rotary Control Knob	Yes	Yes
Variable Temperature Control	Yes	Yes
On/Off LED	Yes	Yes
Anti-slip Mat	Yes	Yes
Temperature Range	30°C-80°C	30-80°C

Dimensions

Appliance Dimensions		
Height (mm)	131	131
Width (mm)	595	595
Depth (mm)	500	500
Built-in Dimensions		
Height (mm)	139	139
Width (mm)	560	560
Depth (mm)	550	550

Performance

Connected Load (W)	430	430
Fuse Rating (A)	13	13

VACUUM SEALERS



KDK911423T



KDK911423M



KDE911423B

Features

Place Settings	Touch	Touch	Touch
Cups and Glass Warming (40°C)	White	White	White
Plate Warming (60°C)	Yes	Yes	Yes
Variable Temperature Control	Yes	Yes	Yes
On/Off LED	Yes	Yes	Yes
Anti-slip Mat	Yes	Yes	Yes
Temperature Range	Yes	Yes	Yes

Dimensions

Appliance Dimensions			
Height (mm)	131	131	131
Width (mm)	595	595	595
Depth (mm)	510	510	510
Built-in Dimensions			
Height (mm)	139	139	139
Width (mm)	560	560	560
Depth (mm)	550	550	550

Performance

Connected Load (W)	400	400	400
Fuse Rating (A)	13	13	13

MICROWAVES



MBE2658SEM



MBB1756SEM



MBB1755SEM

Features

Microwave & Grill			
Solo Microwave	•	•	•
Oven Volume (ltr)	26	17	17
Auto Defrost By Weight Programmes	4	4	4
Default Favourite Auto Menus	3	3	3
Control Type	Command Wheel/ Touch on Glass	Command Wheel/ Touch on Glass	Command Wheel/ Touch on Glass
Electronic Clock/Programmer	•	•	•
Quickstart	•	•	•
Powersave Mode	•	•	•
Programme End Signal	•	•	•

Dimensions

Appliance Dimensions			
Height (mm)	459	371	371
Width (mm)	596	594	494
Depth (mm)	404	316	316
Aperture Dimensions			
Height (mm)	450	360	360
Width (mm)	562	562	462
Depth (mm)	500	300	300

Performance

Microwave Output (W)	900	800	800
Grill Output (W)			
Connected Load (W)	1400	1250	1250
Fuse Rating (A)	10	10	10

INDUCTION HOBS



IAE84881FB



IKK86681FB



IAE84851FB



IKE85651FB



IPE84531FB

Features

Control Type	Touch	Touch	Touch	Touch	Touch
Display	TFT		TFT		
Control Position	Front Right	Front Left & Middle & Right	Front Right	N/A	Front Middle
Bridge Function	Yes	Yes	Yes	Yes	
Automatic Heat Up (Automax)	No			Yes	Yes
Stop & Go	Yes	Yes	Yes	Yes	Yes
Residual Heat Indicator	Yes	Yes	Yes	Yes	Yes
Eco Timer	Yes	Yes	Yes	Yes	Yes
Minute Minder	Yes	Yes	Yes	Yes	Yes
Count Up Timer	Yes	Yes	Yes	Yes	Yes
Pan Sensor	Yes	Yes	Yes	Yes	Yes
Boosters	Yes	Yes	Yes	Yes	Yes
Child Lock	Yes	Yes	Yes	Yes	Yes
Hob ² Hood	Yes	Yes	Yes	Yes	Yes
Pure Black Design					Yes
SenseBoil®					
SenseFry®	Yes		Yes		
SensePro®	Yes				

Zone Specification

Front Left Spec	Induction	Induction	Induction	Induction	Induction
Front Left Rating (W)	2300/3200	2000/3200	2300/3200	2300/3200	2300/3200
Front Left Diameter (mm)	210	180x220	220	210	210
Rear Left Spec	Induction	Induction	Induction	Induction	Induction
Rear Left Rating (W)	2300/3200	2000/3200	2300/3200	2300/3200	2300/3200
Rear Left Diameter (mm)	210	180x220	220	210	210
Front Middle Spec	Induction	Induction		Induction	
Front Middle Rating (W)	1400/2500	2000/3200		2300/3200	
Front Middle Diameter (mm)	145	180x220		240	
Rear Middle Spec		Induction	Induction		
Rear Middle Rating (W)		2300/3200	2300/3200		Induction
Rear Middle Diameter (mm)		180x220mm	210		2300/3200
Front Right Spec		Induction	Induction	Induction	210
Front Right Rating (W)		2000/3200	1800/2800	2300/3200	2300/3200
Front Right Diameter (mm)		180x220	180	210	210
Rear Right Spec	Induction	Induction		Induction	
Rear Right Rating (W)	2300/3600	2000/3200		2300/3200	
Rear Right Diameter (mm)	240	180x220		210	

Dimensions

Appliance Dimensions					
Width (mm)	780	780	780	810	780
Depth (mm)	520	520	520	520	520
Aperture Dimensions					
Height (mm)	44	44	44	44	44
Width (mm)	750	750	750	780	750
Depth (mm)	490	490	490	490	490

Electrical Connection

Connected Load (W)	7350	7350	7350	7350	7400
Fuse Rating (A)	30	30	30	30	30



IAE84421FB



IKE85751FB



IAE84411FB



IKB84401FB

Features

Control Type	Touch	Touch	Touch	Touch
Display				
Control Position	Front Right	Front Middle	Front Middle	Front Right
Bridge Function	Yes	Yes	Yes	Yes
Automatic Heat Up (Automax)	Yes	Yes	Yes	Yes
Stop & Go / Pause	Yes	Yes	Yes	Yes
Residual Heat Indicator	Yes	Yes	Yes	Yes
Eco Timer	Yes	Yes	Yes	Yes
Minute Minder	Yes	Yes	Yes	Yes
Count Up Timer	Yes	Yes	Yes	Yes
Pan Sensor	Yes	Yes	Yes	Yes
Boosters	Yes	Yes	Yes	Yes
Child Lock	Yes	Yes	Yes	Yes
Hob ² Hood	Yes	Yes	Yes	Yes
Pure Black Design				
SenseBoil®	Yes		Yes	
SenseFry®				
SensePro®				

Zone Specification

Front Left Spec	Induction	Induction	Induction	Induction
Front Left Rating (W)	2300/3200	1400/2500	2300/3200	2300/3200
Front Left Diameter (mm)	210	145	210	210
Rear Left Spec	Induction	Induction	Induction	Induction
Rear Left Rating (W)	2300/3200	2300/3200	2300/3200	2300/3200
Rear Left Diameter (mm)	210	210	210	210
Front Middle Spec	Induction	Induction		Induction
Front Middle Rating (W)	1400/2500	2300/3200		2300/3200
Front Middle Diameter (mm)	145	210		210
Rear Middle Spec				
Rear Middle Rating (W)				
Rear Middle Diameter (mm)				
Front Right Spec		Induction	Induction	
Front Right Rating (W)		1400/2500	2300/3200	
Front Right Diameter (mm)		145	210	
Rear Right Spec	Induction	Induction	Induction	Induction
Rear Right Rating (W)	2300/3600	2300/3200	2300/3200	2300/3200
Rear Right Diameter (mm)	240	210	210	210

Dimensions

Appliance Dimensions				
Width (mm)	780	780	780	780
Depth (mm)	520	520	520	520
Aperture Dimensions				
Height (mm)	44	44	44	44
Width (mm)	750	750	750	750
Depth (mm)	490	490	490	490

Electrical Connection

Connected Load (W)	7350	7350	7350	7350
Fuse Rating (A)	30	30	30	30

INDUCTION HOBS



IPE64551FB

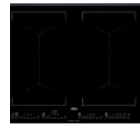

IKE64450FB



IAE64421FB



IAE64411FB

Features

Control Type	Touch	Touch	Touch	Touch
Display				
Control Position	Front Middle	Front Middle	Front Middle	Front Right
Bridge Function	Yes	Yes	Yes	Yes
Automatic Heat Up (Automax)	Yes	Yes	Yes	Yes
Stop & Go	Yes	Yes	Yes	Yes
Residual Heat Indicator	Yes	Yes	Yes	Yes
Eco Timer	Yes	Yes	Yes	Yes
Minute Minder	Yes	Yes	Yes	Yes
Count Up Timer	Yes	Yes	Yes	Yes
Pan Sensor	Yes	Yes	Yes	Yes
Boosters	Yes	Yes	Yes	Yes
Child Lock	Yes	Yes	Yes	Yes
Hob ² Hood	Yes			Yes
Pure Black Design	Yes			
SenseBoil®			Yes	Yes
SenseFry®				
SensePro®				

Zone Specification

Front Left Spec	Induction	Induction	Induction	Induction
Front Left Rating (W)	2300/3200	2300/3200	2300/3200	2300/3700
Front Left Diameter (mm)	210	210	210	210
Rear Left Spec	Induction	Induction	Induction	Induction
Rear Left Rating (W)	2300/3200	2300/3200	2300/3200	1800/2800
Rear Left Diameter (mm)	210	210	210	180
Front Middle Spec				
Front Middle Rating (W)				
Front Middle Diameter (mm)				
Rear Middle Spec				
Rear Middle Rating (W)				
Rear Middle Diameter (mm)				
Front Right Spec	Induction	Induction	Induction	Induction
Front Right Rating (W)	2300/3200	2300/3200	1400/2500	1400/2500
Front Right Diameter (mm)	210	210	145	145
Rear Right Spec	Induction	Induction	Induction	Induction
Rear Right Rating (W)	2300/3200	2300/3200	1800/2800	1800/2800
Rear Right Diameter (mm)	210	210	180	180

Dimensions

Appliance Dimensions				
Width (mm)	590	590	590	590
Depth (mm)	520	520	520	520
Aperture Dimensions				
Height (mm)	44	44	44	44
Width (mm)	560	560	560	560
Depth (mm)	490	490	490	490

Electrical Connection

Connected Load (W)	7400	7350	7350	7350
Fuse Rating (A)	30	30	30	30



IKB64401FB



ILB64334CB



IKE95751FB



IKK93431FB

Features

Control Type	Touch	Touch	Touch	Touch
Display				
Control Position	Front Right	Front Right	Front Middle	Front Middle
Bridge Function			Yes	
Automatic Heat Up (Automax)	Yes	Yes	Yes	Yes
Stop & Go / Pause	Yes	Yes	Yes	Yes
Residual Heat Indicator	Yes	Yes	Yes	Yes
Eco Timer	Yes	Yes	Yes	Yes
Minute Minder	Yes	Yes	Yes	Yes
Count Up Timer	Yes	Yes	Yes	Yes
Pan Sensor		Yes	Yes	Yes
Boosters	Yes	Yes	Yes	Yes
Child Lock	Yes	Yes	Yes	Yes
Hob ² Hood	Yes		Yes	

Pure Black Design

SenseBoil®

SenseFry®

SensePro®

Zone Specification

Front Left Spec	Induction	Induction	Induction	
Front Left Rating (W)	2300/3700	2300/3200	2300/3200	
Front Left Diameter (mm)	210	210	220	
Rear Left Spec	Induction	Induction	Induction	Induction
Rear Left Rating (W)	1800/2800	1800/2800	2300/3200	2300/3200
Rear Left Diameter (mm)	180	185	220	210
Front Middle Spec			Induction	
Front Middle Rating (W)			1800/3700	
Front Middle Diameter (mm)			280	
Rear Middle Spec				Induction
Rear Middle Rating (W)				2300/3200
Rear Middle Diameter (mm)				210
Front Right Spec	Induction	Induction	Induction	
Front Right Rating (W)	1400/2500	1400/2500	1400/2500	
Front Right Diameter (mm)	145	145	145	
Rear Right Spec	Induction	Induction	Induction	Induction
Rear Right Rating (W)	1800/2800	1800/2800	2300/3200	2300/3200
Rear Right Diameter (mm)	180	180	210	210

Dimensions

Appliance Dimensions

Width (mm)	590	590	910	910
Depth (mm)	520	520	520	410
Aperture Dimensions				
Height (mm)	44	44	44	44
Width (mm)	560	560	880	880
Depth (mm)	490	490	490	380

Electrical Connection

Connected Load (W)	7350	3000	7200	6900
Fuse Rating (A)	30	15	30	30

EXTRACTOR HOBS



CCE84779FB / CDE84779FB



CCE84751FB / CDE84751FB

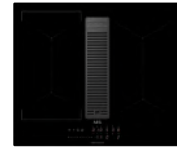

IDE74243IB

Hob Features

Control Type	Touch on Glass Slide Controls	Touch on Glass Slide Controls	Touch Control
Display	LED	LED	LED
Bridge Function	• Double FlexiBridge®	• Double Bridge	• (I)
Automatic Heat Up	•	•	•
Pause	•	•	•
Residual Heat Indicator	•	•	•
Timer	•	•	•
Pan Sensor	•	•	•
Child Lock	•	•	•

Zone Specification

Front Left Spec			
Front Left Rating (W)	2300/3200	2300/3200	1600/1850
Front Left Diameter (mm)	220	210	180x200
Rear Left Spec			
Rear Left Rating (W)	2300/3200	2300/3200	2100/3000
Rear Left Diameter (mm)	220	210	180x200
Front Right Spec			
Front Right Rating (W)	2300/3200	1200/1400	1200/1400
Front Right Diameter (mm)	220	210	160
Rear Right Spec			
Rear Right Rating (W)	2300/3200	2300/3000	2300/3000
Rear Right Diameter (mm)	220	210	200

Cooker Hood Features

Control Type	Touch on Glass Slide Controls	Touch on Glass Slide Controls	Touch Control
Fan Speed	3 + Intensive, Boost and Breeze	3 + Intensive, Boost and Breeze	3 + 2 Intensive
2 in 1 Charcoal & Grease Filter Included	• (CCE84779FB only)	• (CCE84751FB only)	•
Grease Filter Only	Aluminium mesh CDE84779FB only	Aluminium mesh CDE84751FB only	Aluminium mesh
Efficiency Max (m3/h) (Recirculation / External Ducted)	465 / 500	465 / 500	385 / 405
Efficiency Intensive (m3/h) (Recirculation / External Ducted)	585 / 630	585 / 630	495 / 630

Dimensions

Width (mm)	830	830	830
Depth (mm)	515	515	510

Aperture Dimensions

Height (mm)	210	210	210
Width (mm)	780	780	720
Depth (mm)	490	490	510

Electrical Connection

Connection Load (W)	7350	7350	7350
Fuse Rating (A)	32	32	32
Energy Class	A+	A+	A

CERAMIC HOB



HK634060XB

Features

Control Type	Touch
Control Position	Front Right
Automatic Heat Up (Automax)	Yes
Stop & Go	Yes
Residual Heat Indicator	Yes
Minute Minder	Yes
Count Up Timer	Yes
Child Lock	Yes

Zone Specification

Front Left Spec	Dual Hilight
Front Left Rating (W)	750/2200
Front Left Diameter (mm)	120/210
Rear Left Spec	Hilight
Rear Left Rating (W)	1200
Rear Left Diameter (mm)	145
Front Middle Spec	
Front Middle Rating (W)	
Front Middle Diameter (mm)	
Rear Middle Spec	
Rear Middle Rating (W)	
Rear Middle Diameter (mm)	
Front Right Spec	Hilight
Front Right Rating (W)	1200
Front Right Diameter (mm)	145
Rear Right Spec	Dual Hilight
Rear Right Rating (W)	1500/2400
Rear Right Diameter (mm)	170/265

Dimensions

Appliance Dimensions	
Width (mm)	576
Depth (mm)	516
Aperture Dimensions	
Height (mm)	38
Width (mm)	560
Depth (mm)	490

Electrical Connection

Connected Load (W)	7000
Fuse Rating (A)	30

GAS HOBS



HVB95450IB



HKB95450NB



HGB95522YM



HVB75450IB

Features

Control Type	Touch	Rotary	Rotary	Touch
Ignition Type	Auto	Integral	Integral	Auto
Stop & Go	Yes			Yes
Minute Minder	Yes	Yes		Yes
Control Position	Front Middle	Front Middle	Front Middle	Front Middle
LED Display	Red	Red		Red
Pan Supports	Cast Iron	Cast Iron	Cast Iron	Cast Iron
Residual Heat Indicator	Yes	Yes		Yes
Hob ² Hood	Yes	Yes		Yes
Safety Thermocouples	Yes	Yes	Yes	Yes

Zone Specification

Front Left Spec	Semi Rapid Burner	Semi Rapid Burner	Wok Burner	Semi Rapid Burner
Front Left Rating (wh)	1900	2000	6200	1900
Front Left Diameter (mm)	80	80	133	80
Rear Left Spec	Semi Rapid Burner	Semi Rapid Burner		Semi Rapid Burner
Rear Left Rating (wh)	1900	2000		1900
Rear Left Diameter (mm)	80	80		80
Front Middle Spec	Wok Burner		Auxiliary Burner	Wok Burner
Front Middle Rating (wh)	3500		1000	3500
Front Middle Diameter (mm)	128		54	128
Rear Middle Spec		Wok Burner	Semi Rapid Burner	
Rear Middle Rating (wh)		4000	1900	
Rear Middle Diameter (mm)		128	70	
Front Right Spec	Auxiliary Burner	Auxiliary Burner	Rapid Burner	Auxiliary Burner
Front Right Rating (wh)	1000	1000	3000	1000
Front Right Diameter (mm)	65	65	100	65
Rear Right Spec	Semi Rapid Burner	Semi Rapid Burner	Semi Rapid Burner	Semi Rapid Burner
Rear Right Rating (wh)	1900	2000	1900	1900
Rear Right Diameter (mm)	80	80	70	80
Max Gas Power (W)	10200	11000	14000	10200

Dimensions

Appliance Dimensions				
Width (mm)	890	880	857	750
Depth (mm)	510	510	520	510
Aperture Dimensions				
Height (mm)	40	40	60	52
Width (mm)	850	830	830	720
Depth (mm)	490	480	480	490

Electrical Connection

Fuse Rating (A)	13	13	13	13
-----------------	----	----	----	----



HKB75450NB



HGB75420YM

Features

Control Type	Rotary	Rotary
Ignition Type	Integral	Integral
Stop & Go		
Minute Minder	Yes	
Control Position	Front Middle	Front Middle
LED Display	Red	
Pan Supports	Cast Iron	Cast Iron
Residual Heat Indicator	Yes	
Hob ² Hood	Yes	
Safety Thermocouples	Yes	Yes

Zone Specification

Front Left Spec	Semi Rapid Burner	Semi Rapid Burner
Front Left Rating (wh)	2000	1900
Front Left Diameter (mm)	80	70
Rear Left Spec	Semi Rapid Burner	Semi Rapid Burner
Rear Left Rating (wh)	2000	1900
Rear Left Diameter (mm)	80	70
Front Middle Spec		
Front Middle Rating (wh)		
Front Middle Diameter (mm)		
Rear Middle Spec	Wok Burner	Wok Burner
Rear Middle Rating (wh)	3900	4000
Rear Middle Diameter (mm)	128	122
Front Right Spec	Auxiliary Burner	Auxiliary Burner
Front Right Rating (wh)	1000	1000
Front Right Diameter (mm)	65	54
Rear Right Spec	Semi Rapid Burner	Rapid Burner
Rear Right Rating (wh)	2000	3000
Rear Right Diameter (mm)	80	100
Max Gas Power (W)	10900	12000

Dimensions

Appliance Dimensions		
Width (mm)	740	745
Depth (mm)	510	510
Aperture Dimensions		
Height (mm)	45	40
Width (mm)	560	560
Depth (mm)	480	480

Electrical Connection

Fuse Rating (A)	13	13
-----------------	----	----

GAS HOBS



HKB64450NB



HGB64420YM

Features

Control Type	Rotary	Rotary
Ignition Type	Integral	Integral
Stop & Go		
Minute Minder	Yes	
Control Position	Front Middle	Front Right
LED Display	Red	
Pan Supports	Cast Iron	Cast Iron
Residual Heat Indicator	Yes	
Hob ² Hood	Yes	
Safety Thermocouples	Yes	Yes

Zone Specification

Front Left Spec	Wok Burner	Wok Burner
Front Left Rating (wh)	3900	4000
Front Left Diameter (mm)	128	122
Rear Left Spec	Semi Rapid Burner	Semi Rapid Burner
Rear Left Rating (wh)	2000	1900
Rear Left Diameter (mm)	80	70
Front Middle Spec		
Front Middle Rating (wh)		
Front Middle Diameter (mm)		
Rear Middle Spec		
Rear Middle Rating (wh)		
Rear Middle Diameter (mm)		
Front Right Spec	Auxiliary Burner	Auxiliary Burner
Front Right Rating (wh)	1000	1000
Front Right Diameter (mm)	65	54
Rear Right Spec	Semi Rapid Burner	Semi Rapid Burner
Rear Right Rating (wh)	2000	1900
Rear Right Diameter (mm)	80	70
Max Gas Power (W)	8900	8800

Dimensions

Appliance Dimensions		
Width (mm)	590	594
Depth (mm)	520	510
Aperture Dimensions		
Height (mm)	40	40
Width (mm)	560	560
Depth (mm)	480	480

Electrical Connection

Fuse Rating (A)	13	13
-----------------	----	----

MIXED FUEL HOB



HD955100NB

Features

Control Type	Touch/Rotary
Control Position	Front
Automatic Heat Up (Automax)	Yes
Stop & Go	Yes
Residual Heat Indicator	Yes
OKO Timer	Yes
Minute Minder	Yes
Count Up Timer	Yes
Pan Sensor	Yes
Boosters	Yes
Child Lock	Yes

Zone Specification

Front Left Spec	
Front Left Rating (W)	
Front Left Diameter (mm)	
Rear Left Spec	Dual Crown Burner
Rear Left Rating (W)	5000
Rear Left Diameter (mm)	134
Front Middle Spec	Induction
Front Middle Rating (W)	2200/3600
Front Middle Diameter (mm)	210
Rear Middle Spec	Induction
Rear Middle Rating (W)	1400/2500
Rear Middle Diameter (mm)	145
Front Right Spec	Induction
Front Right Rating (W)	1400/2500
Front Right Diameter (mm)	145
Rear Right Spec	Induction
Rear Right Rating (W)	1800/2800
Rear Right Diameter (mm)	180

Dimensions

Appliance Dimensions	
Width (mm)	880
Depth (mm)	520
Aperture Dimensions	
Height (mm)	40
Width (mm)	830
Depth (mm)	490

Electrical Connection

Connected Load (W)	6800
Fuse Rating (A)	30

MODULAR HOB



IKE42640KB

Features

Hob Type	2 Zone MaxiSense
Control Type	ActiveTouch
Fuel Type	Induction
Triple Zone	
Bridge Function	Yes
Automatic Heat Up (Automax)	Yes
Stop & Go	Yes
Residual Heat Indicator	Yes
Minute Minder	Yes
Count Up Timer	Yes
Pan Sensor	Yes
Booster	Yes
Child Lock	Yes
Gas Safety Shut off	

Zone Specification

Front Spec	Induction
Front Rating (kW)	2.3/3.2
Front Diameter (mm)	170x265
Rear Spec	Induction
Rear Rating (kW)	2.3/3.2
Rear Diameter (mm)	170x265

Dimensions

Appliance Dimensions	
Width (mm)	360
Depth (mm)	520
Aperture Dimensions	
Height (mm)	44
Width (mm)	340
Depth (mm)	490

Electrical Connection

Connected Load (W)	3650
Fuse Rating (A)	16
Lpg Conversion Kit	

DESIGNER HOODS



DLE0970M



DLE0630B/W



DLE0431W/B/M

Key Features

Control type	Electronic push button	Electronic push button	Electronic push button
Hob2Hood			
Fan Speed	4	4	4
Breeze function			
Lights	LED spotlight	LED spotlight	LED spotlight
No of lamp x W	5	3	3
Charcoal filter	2; Included	1; Included	1; Included
Charcoal filter type	MCFB29	MCFB29	MCFB29
Ultra charcoal filter	N/A	N/A	N/A
Ultra charcoal filter type	N/A	N/A	N/A
Grease filter Type	Aluminium mesh	Aluminium mesh	Aluminium mesh
Ducted Max (ca. m ³ /h)	N/A	N/A	N/A
Ducted boost (ca. m ³ /h)	N/A	N/A	N/A
Noise (Max setting) Ducted	N/A	N/A	N/A
Recirculation maximum (ca. m ³ /h)	700	350	350
Recirculation boost (ca. m ³ /h)	700	350	350
Noise (Max Setting) Recirculation (dB(A))	72	70	70
Annual energy consumption, kWh/annum	0.0	0.0	0.0
Energy efficiency class	N/A	N/A	N/A
Fluid Dynamic Efficiency Class	N/A	N/A	N/A
Lighting efficiency Class	N/A	N/A	N/A
Grease filter Efficiency	N/A	N/A	N/A
Grease filter Efficiency Class	0.0	0.0	0.0
Off mode power (W)	0.0	0.0	0.0
Stand by Power (W)	0.0	0.0	0.0
Install height (mm)			
Minimum distance from cooking top - electric	50	50	50
Minimum distance from cooking top - gas	65	65	65
Dimensions			
Width	900	900	500
Depth	440	440	500
Height Max	1250	1250	1250
Height of Body	170	170	170
Other			
Air Outlet	N/A	N/A	N/A

HOODS



DIK6180HG



DIE5961HG



DDE5980G



DCK5281HG



DCE5960HM

Overview

Control Type	Touch on glass	Touch on glass	Touch on Glass	Electronic push buttons	Electronic push buttons
Hob ² Hood
Fan Speed	5	4	5	4	4
Breeze Function
Lights	Dimmable LED Stripe	LED Spotlight	LED Strip	Dimmable LED Stripe	Dimmable LED Stripe
No. of Lamp x W	2	4	1	1	1
Charcoal Filter	2; Included	1; Included	2; Included	1; Included	1; Included
Charcoal Filter Type	MCFB58	MCFB58	MCFE38	MCFB60	MCFB60
Ultra Charcoal Filter	2; Accessory	2; Accessory	.	2; Accessory	2; Accessory
Ultra Charcoal Filter Type	MCFB59	MCFB59	.	MCFB62	MCFB62
Grease Filter Type	Aluminium mesh	Aluminium mesh	Stainless Steel Design Filter	Aluminium mesh	Aluminium mesh
Ducted Maximum (ca. m ³ /h)	500	400	350	590	590
Ducted Boost (ca. m ³ /h)	750	700	700	720	710
Noise (Max. Setting) Ducted (dB(A))	65	65	70	70	63
Recirculation Maximum (ca. m ³ /h)	475	380	335	580	580
Recirculation Boost (ca. m ³ /h)	530	480	680	700	690
Noise (Max. Setting) Recirculation (dB(A))	69	66	61	76	67
Annual Energy Consumption, kWh/annum	43.1	55.2	59.5	40.1	55
Energy Efficiency Class	A+	A	A	A+	A
Fluid Dynamic Efficiency Class	A	A	A	A	A
Lighting Efficiency Class	A	A	A	A	A
Grease Filter Efficiency	75.1	85.1	65.1	65.1	65.1
Grease Filter Efficiency Class	C	B	D	D	D
Off Mode Power (W)	0.49	0.49	0.85	0.49	0.49
Stand-by Power (W)
Installation Height (mm)					
Minimum Distance from Cooking Top – Electric	50	50	30 – 50	75	75
Minimum Distance from Cooking Top – Gas	65	65	30 – 50	75	75
Dimensions (mm)					
Width	1000	898	880	1200	900
Depth	700	606	95	700	700
Height Max	1150	1175	407	273	582
Height of Body	75	60	407	3	3
Other					
Air Outlet	150	150	150	150	150

HOODS



Overview

Control Type	Touch on glass	Touch on glass	Touch on glass	Touch on glass	Touch on glass
Hob+Hood
Fan Speed	5	4	4	5	5
Breeze Function
Lights	Dimmable LED Stripe	Squared LED	Squared LED	Dimmable LED Stripe	Dimmable LED Stripe
No. of Lamp x W	1	2	2	1	1
Charcoal Filter	2; Included	2; Included	2; Included	1; Included	1; Included
Charcoal Filter Type	MCFB63	ECFB02	ECFB02	MCFB58	MCFB58
Ultra Charcoal Filter	2; Accessory	2; Accessory	2; Accessory	2; Accessory	2; Accessory
Ultra Charcoal Filter Type	MCFB64	MCFB52	MCFB52	MCFB59	MCFB59
Grease Filter Type	Aluminium mesh	Aluminium mesh	Aluminium mesh	Aluminium mesh	Aluminium mesh
Ducted Maximum (ca. m ³ /h)	500	400	400	500	500
Ducted Boost (ca. m ³ /h)	750	700	700	750	750
Noise (Max. Setting) Ducted (dB(A))	66	64	64	65	65
Recirculation Maximum (ca. m ³ /h)	550	310	310	475	475
Recirculation Boost (ca. m ³ /h)	720	425	425	530	530
Noise (Max. Setting) Recirculation (dB(A))	68	64	64	69	69
Annual Energy Consumption, kWh/annum	39,4	51,1	51,1	41,5	41,5
Energy Efficiency Class	A+	A	A	A+	A+
Fluid Dynamic Efficiency Class	A	A	A	A	A
Lighting Efficiency Class	A	A	A	A	A
Grease Filter Efficiency	65,1	65,1	65,1	75,1	75,1
Grease Filter Efficiency Class	D	D	D	C	C
Off Mode Power (W)	0,49	0,49	0,49	0,49	0,49
Stand-by Power (W)
Installation Height (mm)					
Minimum Distance from Cooking Top – Electric	50	50	50	50	50
Minimum Distance from Cooking Top – Gas	50	50	50	65	65
Dimensions (mm)					
Width	896	898	598	898	598
Depth	456	418	418	455	455
Height Max	1260	1265	1265	1218	1218
Height of Body	380	380	380	75	75
Other					
Air Outlet	150	150	150	150	150



DBE5961HG



DBE5761HG



DBE5661HG



DKB4950M



DKB4650M

Overview

Control Type	Touch on glass	Touch on glass	Touch on glass	Mechanical Push Buttons	Mechanical Push Buttons
Hob ² Hood					
Fan Speed	4	4	4	3	3
Breeze Function					
Lights	LED Spotlight	LED Spotlight	LED Spotlight	LED Spotlight	LED Spotlight
No. of Lamp x W	2	2	2	2	2
Charcoal Filter	1; Included	1; Included	1; Included	1; Included	1; Included
Charcoal Filter Type	MCFB58	MCFB58	MCFB58	MCFE01	MCFE01
Ultra Charcoal Filter	2; Accessory	2; Accessory	2; Accessory	1; Accessory	1; Accessory
Ultra Charcoal Filter Type	MCFB59	MCFB59	MCFB59	MCFE11	MCFE11
Grease Filter Type	Aluminium mesh	Aluminium mesh	Aluminium mesh	Aluminium Cassette	Aluminium Cassette
Ducted Maximum (ca. m ³ /hh)	400	400	400	603	603
Ducted Boost (ca. m ³ /hh)	700	700	700	-	-
Noise (Max. Setting) Ducted (dB(A))	65	65	65	69	69
Recirculation Maximum (ca. m ³ /h)	380	380	380	400	400
Recirculation Boost (ca. m ³ /h)	480	480	480	-	-
Noise (Max. Setting) Recirculation (dB(A))	66	66	66	75	75
Annual Energy Consumption, kWh/annum	51,5	51,5	51,5	81,9	81,9
Energy Efficiency Class	A	A	A	B	B
Fluid Dynamic Efficiency Class	A	A	A	B	B
Lighting Efficiency Class	A	A	A	F	F
Grease Filter Efficiency	851	851	851	76	76
Grease Filter Efficiency Class	B	B	B	C	C
Off Mode Power (W)	0,49	0,49	0,49		
Stand-by Power (W)					
Installation Height (mm)					
Minimum Distance from Cooking Top – Electric	50	50	50	50	50
Minimum Distance from Cooking Top – Gas	65	65	65	65	65
Dimensions (mm)					
Width	898	698	598	898	598
Depth	455	455	455	500	500
Height Max	1204	1204	1204	1090	1090
Height of Body	60	60	60	40	40
Other					
Air Outlet	150	150	150	150	150

HOODS



DGE5861HM



DGE5661HM



DGE5861HB



DGE5661HB



DGB3850M

Overview

Control Type	Electronic push buttons	Electronic push buttons	Electronic push buttons	Electronic push buttons	Electronic Push Buttons
Hob ² Hood					
Fan Speed	4	4	4	4	4
Breeze Function					
Lights	LED Spotlight	LED Spotlight	LED Spotlight	LED Spotlight	LED
No. of Lamp x W	2	2	2	2	2
Charcoal Filter	1; Included	1; Included	1; Included	1; Included	2; Included
Charcoal Filter Type	ECFB01	ECFB01	ECFB01	ECFB01	ECFB02
Ultra Charcoal Filter	1; Accessory	1; Accessory	1; Accessory	1; Accessory	2; Accessory
Ultra Charcoal Filter Type	ECFBLL02	ECFBLL02	ECFBLL02	ECFBLL02	ECFBLL01
Grease Filter Type	Aluminium cassette	Aluminium cassette	Aluminium cassette	Aluminium cassette	Stainless Steel
Ducted Maximum (ca. m ³ /h)	580	580	580	580	600
Ducted Boost (ca. m ³ /h)	700	700	700	700	
Noise (Max. Setting) Ducted (dB(A))	70	70	70	70	63
Recirculation Maximum (ca. m ³ /h)	430	430	430	430	350
Recirculation Boost (ca. m ³ /h)	435	435	435	435	
Noise (Max. Setting) Recirculation (dB(A))	74	74	74	74	70
Annual Energy Consumption, kWh/annum	54.7	54.7	54.7	54.7	96.5
Energy Efficiency Class	A	A	A	A	C
Fluid Dynamic Efficiency Class	A	A	A	A	D
Lighting Efficiency Class	A	A	A	A	A
Grease Filter Efficiency	65.1	65.1	65.1	65.1	83.5
Grease Filter Efficiency Class	D	D	D	D	C
Off Mode Power (W)	0.49	0.49	0.49	0.49	
Stand-by Power (W)					
Installation Height (mm)					
Minimum Distance from Cooking Top – Electric	50	50	50	50	50
Minimum Distance from Cooking Top – Gas	57	57	57	57	65
Dimensions (mm)					
Width	770	540	770	770	700
Depth	300	300	300	300	285
Height Max	331	331	331	331	245
Height of Body					245
Other					
Air Outlet	150	150	150	150	150



DPB3932S



DPB3632S



DEB2631S

Overview

Control Type	Mechanical Push Buttons	Mechanical Push Buttons	Electronic Slider
Hob ² Hood			
Fan Speed	3	3	Continuous + boost
Breeze Function			
Lights	LED	LED	LED
No. of Lamp x W	2	2	2
Charcoal Filter	2; Included	2; Included	1; Included
Charcoal Filter Type	ECFB03	ECFB03	Type 57
Ultra Charcoal Filter			-
Ultra Charcoal Filter Type			-
Grease Filter Type	Aluminium Cassette	Aluminium Cassette	Aluminium Cassette
Ducted Maximum (ca. m ³ /h)	370	370	352
Ducted Boost (ca. m ³ /h)			
Noise (Max. Setting) Ducted (dB(A))	68	68	62
Recirculation Maximum (ca. m ³ /h)	125	125	252
Recirculation Boost (ca. m ³ /h)			
Noise (Max. Setting) Recirculation (dB(A))	72	72	67
Annual Energy Consumption, kWh/annum	48,9	48,9	106,1
Energy Efficiency Class	C	C	D
Fluid Dynamic Efficiency Class	D	D	D
Lighting Efficiency Class	E	E	A
Grease Filter Efficiency	721	721	66
Grease Filter Efficiency Class	D	D	D
Off Mode Power (W)			
Stand-by Power (W)			
Installation Height (mm)			
Minimum Distance from Cooking Top – Electric	50	50	50
Minimum Distance from Cooking Top – Gas	65	65	70
Dimensions (mm)			
Width	898	598	598
Depth	284	284	270
Height Max	180	180	400
Height of Body	40	40	400
Other			
Air Outlet	150	150	120

DISHWASHERS



FSK93847P



FSE83837P



FSE74747P



FSK75757P

Capacity (Number of IEC Place Settings)	14	14	15	14
XXL Tub (Large Interior)	•	•	•	•
Control Type	Touch Control	Touch Control	Touch Control	Touch Control
Connected				
Number of Temperatures	4	4	4	4
Number of Programmes	7	7	7	7
Automatic 45°C–70°C Programme	•	•	•	•
Quickwash 60°C 30 Min Programme	•	•	•	•
Eco Programme	•	•	•	•
160 min programme	•	•	•	•
90 min programme	•	•	•	•
60 min programme	•	•	•	•
Maintenance Cycle / Machine care	•	•	•	•
Extra silent Programme				
Glasscare Option	•	•	•	•
Xtra Power Option	•	•	•	•
SprayZone Option				
AirDry Technology (Automatic door opening)	•	•	•	•
Glass care Soft Spikes	•	•	•	•
Glass care Soft Grips	•	•	•	•
DelayStart	•	•	•	•
Time Remaining	•	•	•	•
ComfortLift	•	•	•	•
Satellite spray arm	•	•	•	•
Ceiling spray arm	•	•	•	•
Height adjustable upper basket	•	•	•	•
Foldable plate racks - bottom basket	•	•	•	•
Foldable cup shelves - bottom basket	•	•	•	•
Lower basket glass holder			•	
SprayZone				
Time beam - spotlight	•			•
Light beam - spotlight		•	•	
Hinges	Sliding Hinges	Sliding Hinges	Sliding Hinges	Sliding Hinges
Dimensions				
Appliance Dimensions				
Height	818	818	818	818
Width	596	596	596	596
Depth	550	550	550	550
Aperture dimensions				
Built-in Height	820	820	820	820
Built-in Width	900	900	900	900
Built-in Depth	600	600	600	600
Furniture door dimensions				
Door Height (Min – Max)	670-820	670-820	670-820	670-820
Door Weight (Min – Max)	1.5-10	1.5-10	1.5-10	1.5-10
Performance				
Energy consumption / 100 cycles (kWh)	85	85	86	64
Energy efficiency class (EEC)	D	D	C	B
Energy Efficiency Index (EEI)	499	499	439	379
Energy consumption / cycle (kWh)	0.848	0.848	0.86	0.664
Water consumption / cycle (l)	11	11	11	99
Programme duration (min)(E20)	240	240	240	240
Airborne acoustical noise emissions (dB(A) re 1 pW)	39	44	44	42
Airborne acoustical noise emission class	B	B	B	B
Cleaning performance index	1.121	1.121	1.121	1.121
Drying performance index	1.061	1.061	1.061	1.061
Off-mode (W)	0.5	0.5	0.5	0.5
Standby mode (W)	0.5	0.5	0.5	0.5
Delay start (W)	4	4	4	4
Networked standby (W)	2	2	2	2
Other				
Voltage	220-240	220-240	220-240	220-240
Frequency	50/60	50/60	50/60	50/60
Connected Load	1550-2200	1550-2200	1550-2200	1550-2200
Fuse Rating	10	10	10	10
Minimum Water Pressure 1 bar/15 psi	•	•	•	•
Inlet Hose with 3/4" BSP Thread Hose Connection	•	•	•	•
Water Softener				
Water Supply (Max. 60°)	Cold or Hot	Cold or Hot	Cold or Hot	Cold or Hot
Salt Refill Indicator	•	•	•	•
Rinse Aid Refill Indicator	•	•	•	•
Water Hardness Setting	•	•	•	•
Top and side fixing brackets	•	•	•	•
Worktop steam protection	•	•	•	•



FSS63607P



FSK52917Z



FSB42607Z



FSE72507P

Capacity (Number of IEC Place Settings)	13	14	13	9
XXL Tub (Large Interior)				
Control Type	Touch control	Touch control	Touch control	Electronic
Connected				
Number of Temperatures	4	3	2	4
Number of Programmes	7	7	5	7
Automatic 45°C–70°C Programme	•	•	•	•
Quickwash 60°C, 30 Min Programme	•	•	•	•
Eco Programme	•	•	•	•
160 min programme	•	•	•	•
90 min programme	•	•	•	•
60 min programme	•	•	•	•
Maintenance Cycle / Machine care	•	•	•	•
Extra silent Option	•	•	•	•
Glasscare Option	•	•	•	•
Xtra Power Option	•	•	•	•
SprayZone Option	•	•	•	•
AirDry Technology (Automatic door opening)	•	•	•	•
Glass care, Soft Spikes	•	•	•	•
Glass care, Soft Grips	•	•	•	•
DelayStart	•	•	•	•
Time Remaining	•	•	•	•
ComfortLift	•	•	•	•
Satellite spray arm	•	•	•	•
Ceiling spray arm	•	•	•	•
Height adjustable upper basket	•	•	•	•
Foldable plate racks - bottom basket	•	•	•	•
Foldable cup shelves - bottom basket	•	•	•	•
Lower basket glass holder	•	•	•	•
SprayZone	•	•	•	•
Time beam - spotlight	•	•	•	•
Light beam - spotlight	•	•	•	•
Hinges	Sliding Hinges	Sliding Hinges	Sliding Hinges	Sliding Hinges
Dimensions				
Appliance Dimensions				
Height	818	818	818	818
Width	596	596	596	446
Depth	550	550	550	550
Aperture dimensions				
Built-in Height	820	820	820	820-880
Built-in Width	880	880	880	450
Built-in Depth	600	600	600	550
Furniture door dimensions				
Door Height (Min – Max)	670-820	645-776	645-776	645-776
Door Weight (Min – Max)	1.5-10	2.0-10	2.0-10	2.0-6.0KG
Performance				
Energy consumption / 100 cycles (kWh)	84	95	94	75
Energy efficiency class (EEC)	D	E	E	E
Energy Efficiency Index (EEI)	499	559	559	559
Energy consumption / cycle (kWh)	0.835	0.950	0.936	0.754
Water consumption / cycle (l)	10.5	10.5	9.9	9.9
Programme duration (min)(E20)	240	240	227	240
Airborne acoustical noise emissions (dB(A) re 1 pW)	44	44	46	44
Airborne acoustical noise emission class	B	B	C	B
Cleaning performance index	1.121	1.121	1.121	1.121
Drying performance index	1.061	1.061	1.061	1.061
Off-mode (W)	0.5	0.5	0.5	0.5
Standby mode (W)	0.5	0.5	0.5	0.5
Delay start (W)	4	4	4	4
Networked standby (W)	2	2	2	2
Other				
Voltage	220–240	220-240	200-240	220-240
Frequency	50/60	50/60	50/60	50/60
Connected Load	1550-2200	1550-2200	1550-2200	1550-2200
Fuse Rating	10	10	10	10
Minimum Water Pressure 1 bar/15 psi	•	•	•	•
Inlet Hose with 3/4" BSP Thread Hose Connection	•	•	•	•
Water Softener	•	•	•	•
Water Supply (Max. 60°)	Cold or Hot	Cold or Hot	Cold or Hot	Cold or Hot
Salt Refill Indicator	•	•	•	•
Rinse Aid Refill Indicator	•	•	•	•
Water Hardness Setting	•	•	•	•
Top and side fixing brackets	•	•	•	•
Worktop steam protection	•	•	•	•

WASHING MACHINES



L9FEC966R



L8FEE965R



L7FEE845R



L6FBG941CA



L7FC8432BI

Overview

Wash Capacity (kg)	9	9	8	9	8
Spin Speed (rpm)	1600	1600	1400	1400	1400
Display	Large Display	Medium Display	Medium Display	Medium Display	Medium Display
Fascia Panel	Stainless Steel	Matte Silver	Matte Silver	White	Silver
Door Colour/Type	Silver	Silver	Silver	White	Silver

Technology

9000 Series Technology	•				
8000 Series Technology	•	•			
7000 Series Technology	•	•	•		•
6000 Series Technology	•	•	•	•	•

Awards

Woolmark	Green	Green	Blue	Blue	Blue
Ariel + Lenor Certified	•	•	•	•	•

Programmes

ColourPro	•				
OKOPower	•	•			
Cottons	•	•	•	•	•
Eco 40-60	•	•	•	•	•
Synthetics	•	•	•	•	•
Delicates	•	•	•	•	•
Wool					
Wool/Silk	•	•	•	•	•
Down Jacket					
20min 3kg	•	•	•	•	•
Steam	•	•	•		•
Spin/Drain				•	•
Outdoor	•	•	•	•	•
Duvet					
Anti Allergy	•	•	•	•	•
Easy Iron				•	
Sport			•		
Denim					•

Options

Steam	•	•	•		•
Anti Allergy	•	•	•		
Start/Pause	•	•	•	•	•
Temp Selection	•	•	•	•	•
Spin Selection	•	•	•	•	•
Stains/Prewash	•	•	•	•	•
Rinse	•	•	•	•	•
Time Saving	•	•	•	•	•
Delayed Start	•	•	•	•	•

Energy and Water Performance

Energy Efficiency Class	A	A	C	A	D
Spin Drying Efficiency Class	B	B	B	B	B
Airborne Acoustical Noise Emission Class	B	B	B	B	A
Airborne Acoustical Noise Emissions (dB)	75	76	75	75	68
Energy Consumption / 100 Cycles (kWh)	49	49	63	49	73
Water Consumption Per Cycle (L)	49	46	47	50	47
Cycle Duration, Program Eco 40-60 (h:min)	03:40	03:40	03:30	03:40	03:30

Dimensions

Height (mm)	850	850	850	850	819
Width (mm)	600	600	600	600	596
Depth Max (mm)	660	660	600	660	553
Net Weight (kg)	80.5	78.5	72.5	76.5	71.5
Power Cord Length (m)	1.5	1.5	1.8	1.8	1.45

TUMBLE DRYERS



T8DEC846R



T7DEE845R



T6DBG821N

Overview

Dry Capacity (kg)	8	8	8
Display	Large Display	Medium Display	Medium Display
Controls	Dial and Touch Buttons	Dial and Touch Buttons	Dial and Touch Buttons
Fascia Panel	Stainless Steel	Matte Silver	White
Door Colour/Type	Premium Silver Door	Premium Silver Door	White Door

Technology

8000 Series Technology	•		
7000 Series Technology	•	•	
6000 Series Technology	•	•	•

Awards

Woolmark	Blue		
----------	------	--	--

Programmes

Cottons	•	•	•
Cotton Eco			•
Synthetics	•	•	•
Refresh			
Delicates			•
Wool	•	•	
Wool Refresh			
Mixed	•	•	•
Silk	•	•	
Bedlinen	•	•	•
Easy Iron	•	•	•
Outdoor	•		
Duvet	•	•	•
Sports	•	•	•
Active Wear		•	
Jeans			•
Freshen Up			
Time 30			
Cottons – Extra Dry			•
Cottons – Strong Dry			
Cottons – Cupboard Dry			•
Cottons – Iron Dry			•
Synthetics – Extra Dry			•
Synthetics – Cupboard Dry			•
Synthetics – Iron Dry			•

Options

Delay Start	•	•	•
Delicate			•
Drying Mode			
Anti-crease	•	•	•
Dryness Level	•	•	•
Time Drying	•	•	•
Start/Pause	•	•	•
Child Lock	•	•	
Quiet	•		
Steam Level			
Sensitive			
Buzzer			
Refresh	•	•	

Energy Performance

Energy Efficiency Class	A++	A++	B
Annual Energy Consumption (kWh)	235	235	561
Drying Noise (dB)	66	66	65
Stand-by Power (W)	19	19	19

Dimensions

Height (mm)	850	850	850
Width (mm)	600	600	596
Depth Max (mm)	665	665	626
Net Weight (kg)	48.26	48.46	38.46
Power Cord Length (mm)	1450	1450	1450

WASHER DRYERS



L7WEE965R



L7WBG751R



L7WC8632BI

Overview

Wash Capacity (kg)	9	7	8
Dry Capacity (kg)	6	5	4
Spin Speed (rpm)	1600	1400	1600
Display	Medium Display	Small Display	Medium Display
Controls	Dial and Touch Buttons	Dial and Touch Buttons	Dial and Touch Buttons
Fascia Panel	Silver	White	Silver
Door Colour/Type	Silver	White	White

Technology

9000 Series			
8000 Series			
7000 Series	•	•	•
6000 Series	•	•	•

Awards

Woolmark	Blue	Blue	Blue
Ariel + Lenor Certified		•	•

Programmes

Cottons	•	•	•
Eco 40-60	•	•	•
Synthetics	•	•	•
Delicates	•	•	•
Wool	•	•	•
Denim			•
Silk			
Non Stop 3h/3kg			
Steam	•	•	•
Spin/Drain		•	•
Outdoor	•	•	•
Duvet			
Anti Allergy	•		•
Sport			•
Non Stop 60min	•		•
Rinse	•	•	•
Machine Clean			•
Quick 20 Wash & Dry 60		•	

Options

Start/Pause	•	•	•
Temp Selection	•	•	•
Spin Selection	•	•	•
Stains/Prewash	•	•	•
Extra Rinse			
Time Saving			•
Delayed Start	•	•	•
Quick Wash	•	•	
Anti-Crease			
Wash/Dry mode			•
Time Drying	•	•	•
Auto Drying	•	•	•
Mode	•	•	
Child Lock			

Energy and Water Performance

Energy Efficiency Wash Class	A	B	D
Energy Efficiency Wash and Dry Class	E	E	E
Spin Drying Efficiency Class	B	B	B
Airborne Acoustical Noise Emission Class	B	B	A
Airborne Acoustical Noise Emissions (dB)	76	75	70
Energy Consumption Wash / 100 Cycles (kWh)	49	52	73
Energy Consumption Wash Dry / 100 Cycles (kWh)	376	325	266
Water Consumption Per Wash Cycle (L)	46	41	47
Water Consumption Per Wash Dry Cycle (L)	70	67	60
Cycle Duration, Wash Program Eco 40-60 (h:min)	03:04	03:25	03:30
Cycle Duration, Wash Dry Program Eco 40-60 (h:min)	08:05	06:20	06:15

Dimensions

Height (mm)	847	847	820
Width (mm)	597	597	596
Depth Max (mm)	631	631	540
Net Weight (kg)	78,5	69,5	72,5
Power Cord Length (m)	1,8	1,8	1,5

INSTALLATION DIAGRAMS

AEG has always been committed to supporting its retail partners and professional installers by providing them with best in class installation solutions. AEG kitchens are simple to install and use only one Torx T20 screwdriver to install all of our appliances, allowing installers to save time. In 2018, AEG launched a first of its kind Installer App, giving professional installers access to installation information at their fingertips.

IN THIS SECTION

Refrigeration

- Integrated Fridge Freezers
- Integrated Fridges and Freezers
- Freestanding Fridge Freezers
- Wine Cooling

Cooking

- Single Ovens
- Built-In Double Ovens
- Built-Under Double Oven
- Compacts
- Microwave Ovens
- Hobs
- Hoods

Dishwashers

- Fully Integrated Dishwashers
- Slimline Fully Integrated Dishwasher

Laundry

- Built-in Washing Machine
- Built-in Washer Dryer



Only one Torx **T20** screwdriver to install **all** appliances



Not having to change tools saves **time**



Electrolux is the first manufacturer to design an **installation app*** specifically for professional installers

*The app is available for download on Apple and Android mobile phones.

INTEGRATED FRIDGE FREEZERS

SCE818C5TC, SCE818E5TC, SCE818E6TC

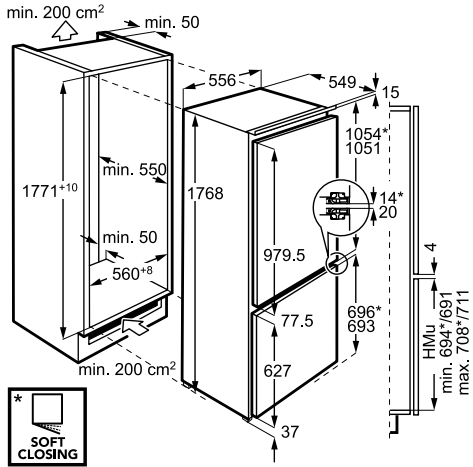

SCE818E6NS

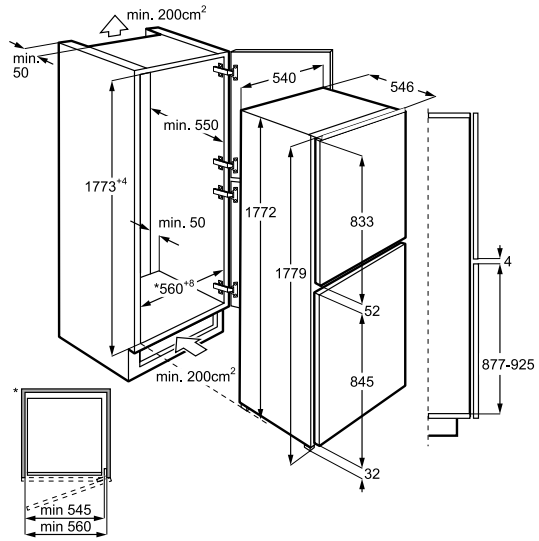

SCE818E8TS

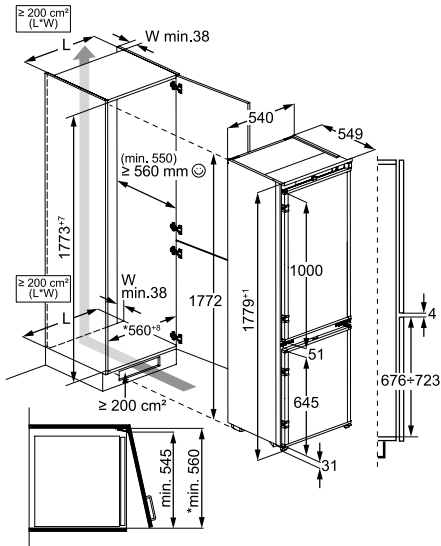

SCB614F1LS

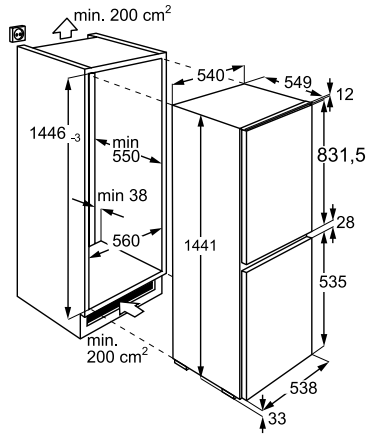

SCE819E5TS, SCE819E7TS

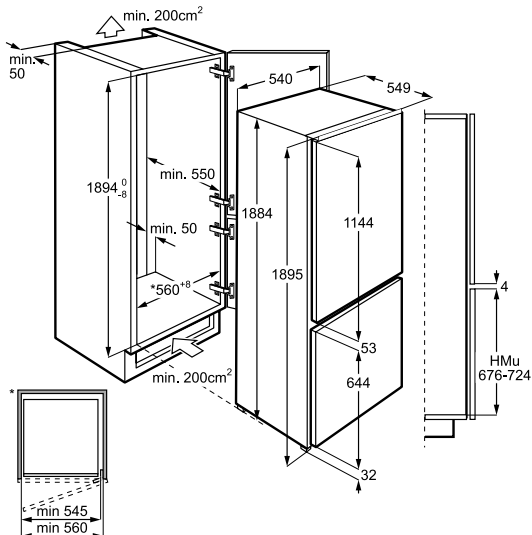

SIDE BY SIDE FRIDGE FREEZERS

RMB76111NX

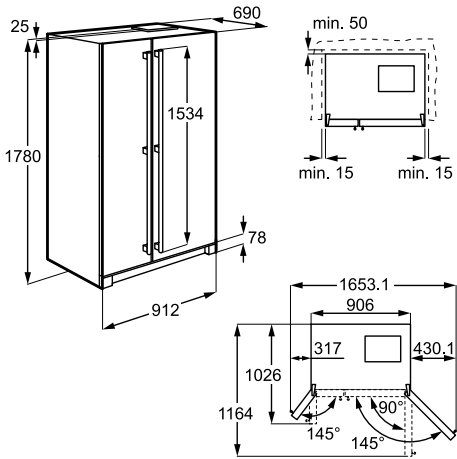

WINE COOLING

AWUS052B5B

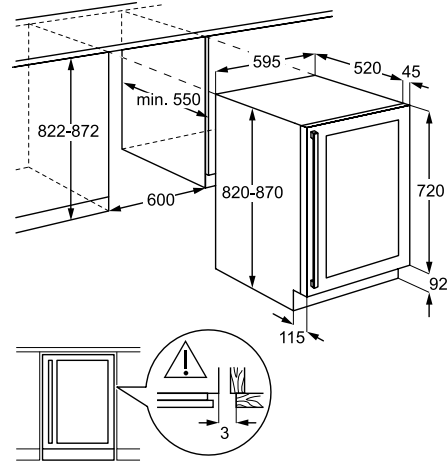

RMB854F9UX

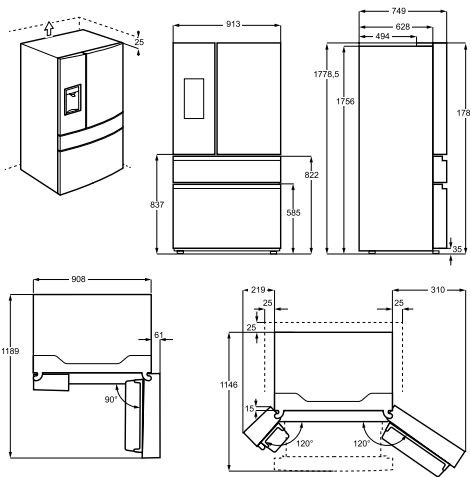

AWUS020B5B

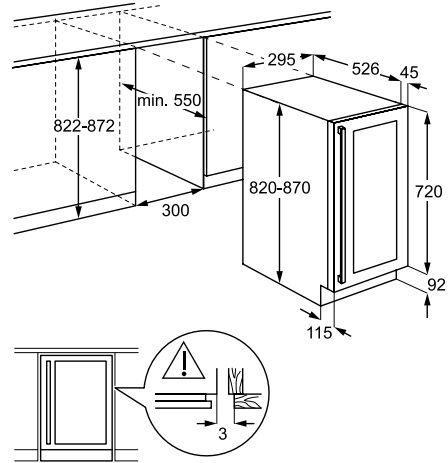

COMPACT WINE COOLER

KWK884520M, KWK884520T

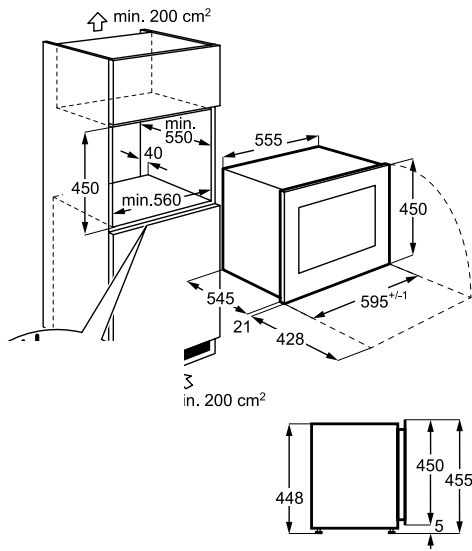

SINGLE OVENS

ALL MODELS EXCLUDING BPK744L21M, BPK744R21M

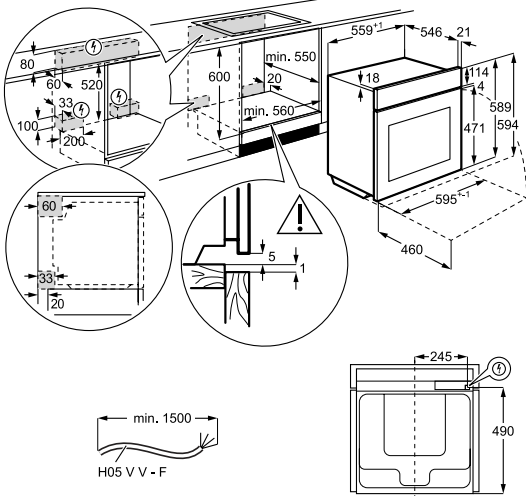

BPK744L21M, BPK744R21M

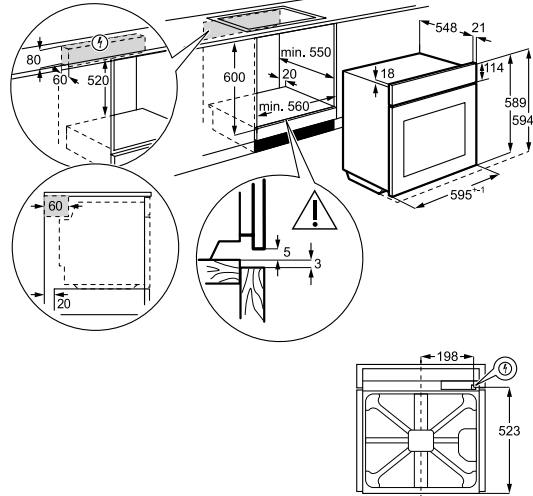

DOUBLE OVENS

DCK731110M, DCK431110M BUILT-IN

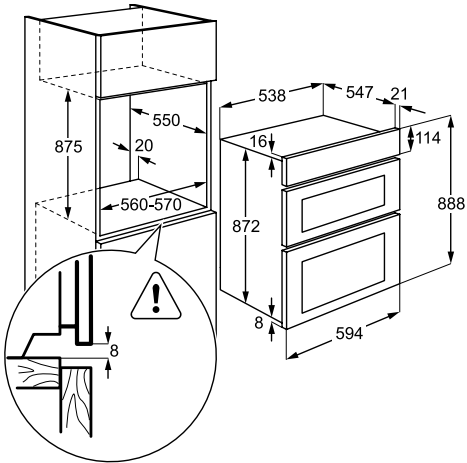

DUK731110M BUILT UNDER

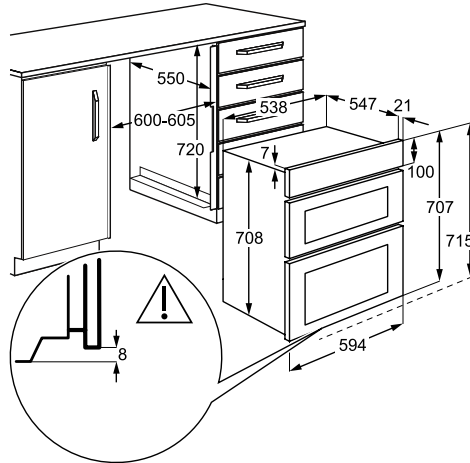

COMPACT OVENS

ALL MODELS EXCLUDING COFFEE MACHINE

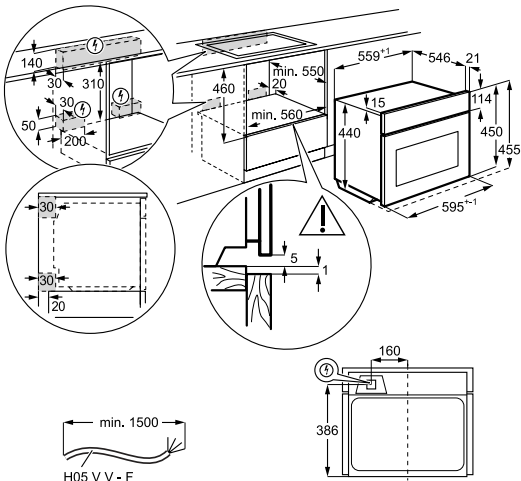

BEAN TO CUP COFFEE MACHINES

KKK994500M, KKK994500T

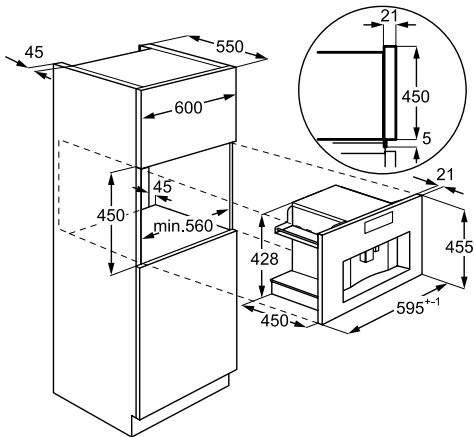

KKK884500M

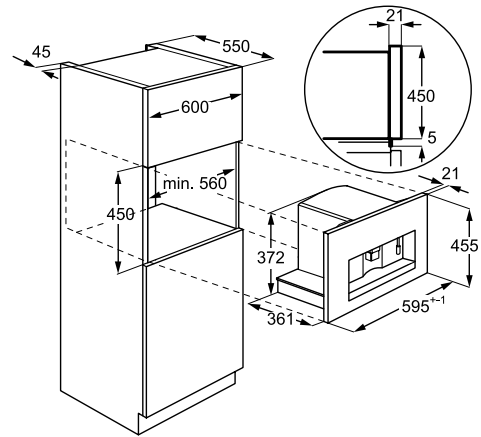

WARMING DRAWERS

KDK912924M, KDE912924M

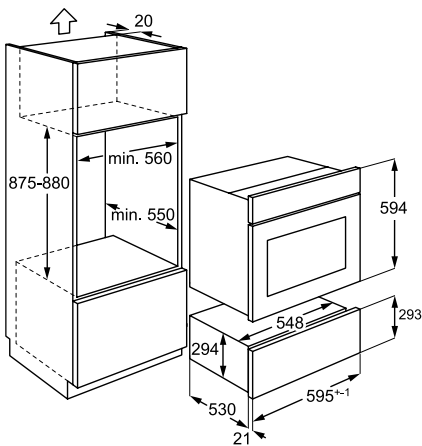

KDK911424M, KDK911424T, KDE911424M, KDE911424B

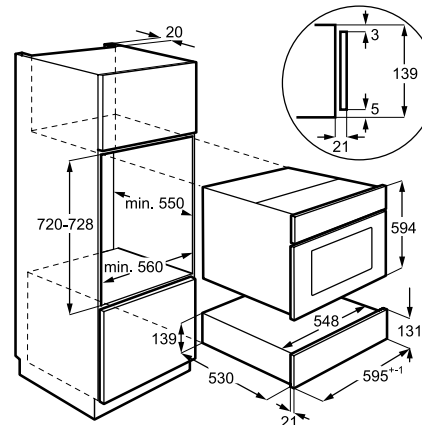

VAC SEALERS

KDK911423M, KDK911424T, KDE911423B

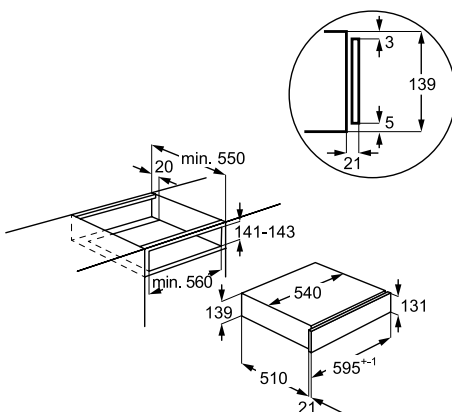

MICROWAVE OVENS

MBE2658SEM

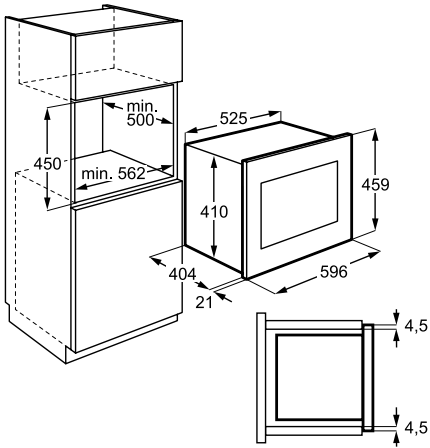

MBB1756SEM, MBB1755SEM

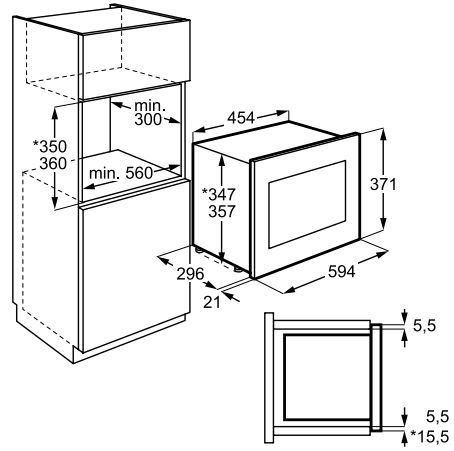

*For perfect horizontal alignment please check the individual product dimensions.

INDUCTION HOBS

**IAE844881FB, IAE844851FB, IPE84531FB, IAE84421FB,
IKE85751FB, IAE84411FB, IKB84401FB, IKK86681FB**

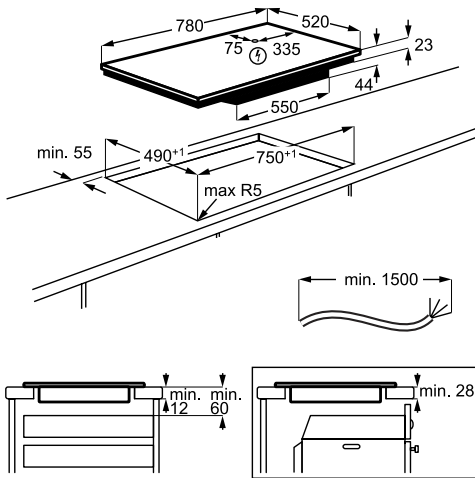

IKE85651FB

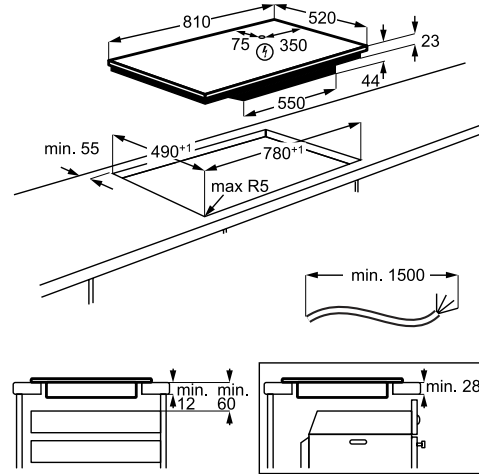

**IPE64551FB, IKE64450FB, IAE64421FB, IAE64411FB,
IKB64401FB, ILB64334CB**

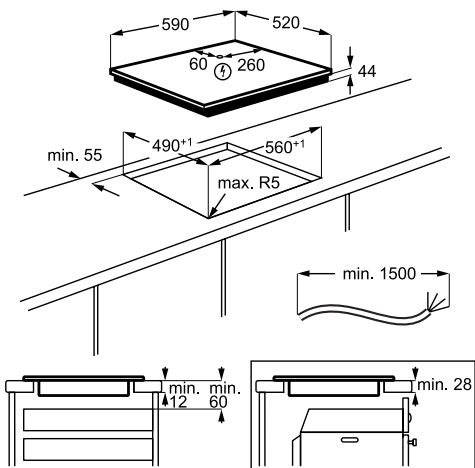

INDUCTION HOBS

IKE95751FB

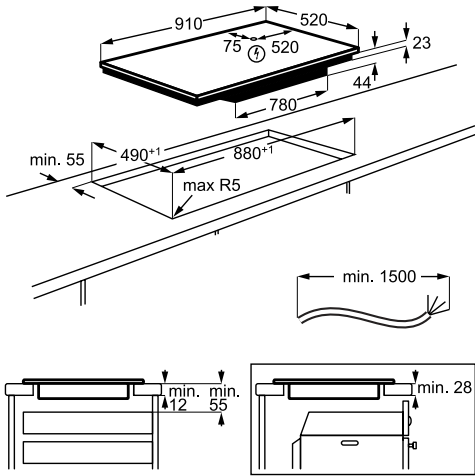

IKK93431FB

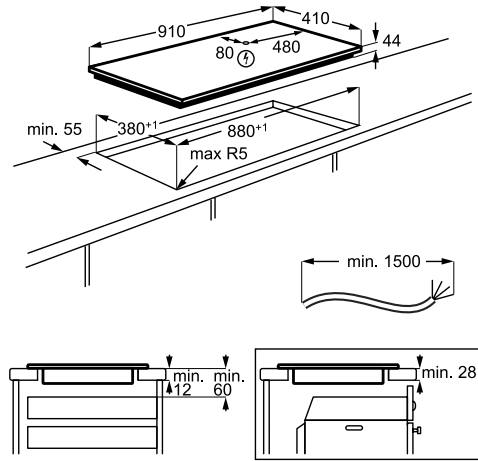

EXTRACTOR HOBS

CCE84779FB, CDE84779FB, CCE84751FB, CDE84751FB

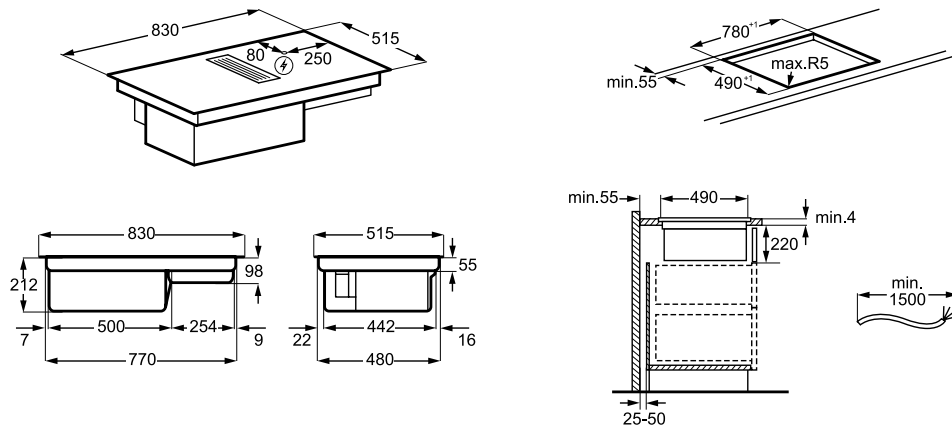

IDE74243IB

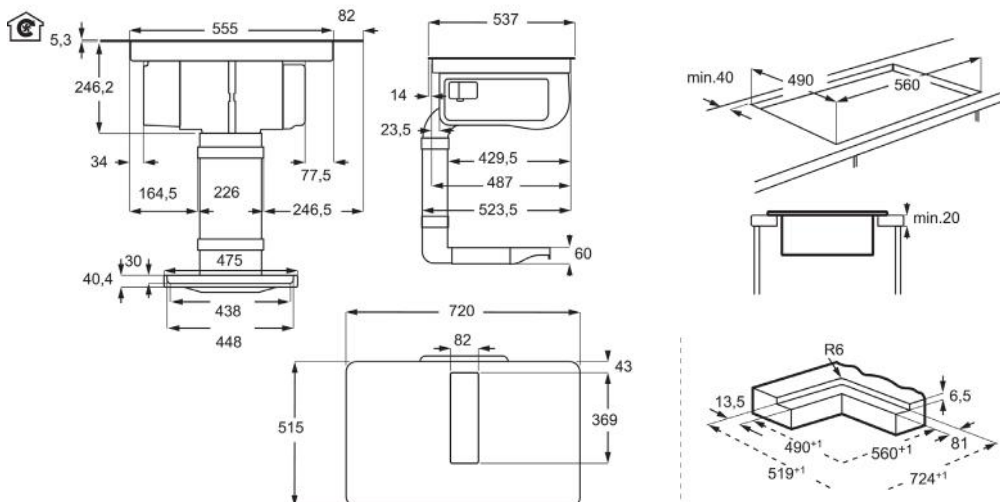

CERAMIC HOB

HK634060XB

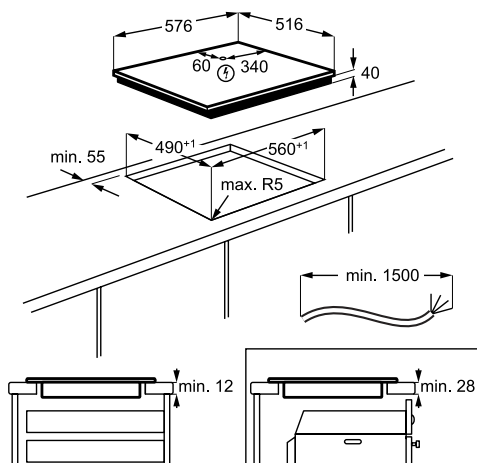

GAS HOBS

HVB95450IB

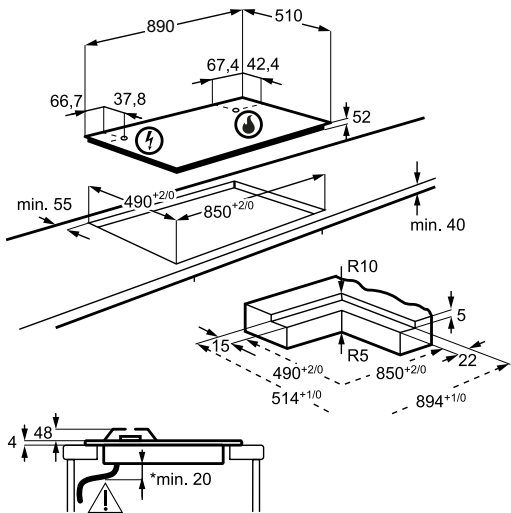

HKB95450NB

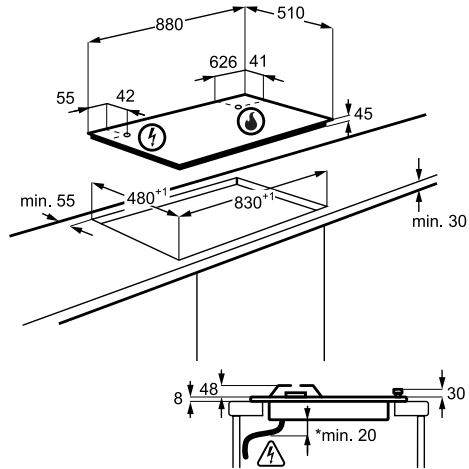

HGB95522YM

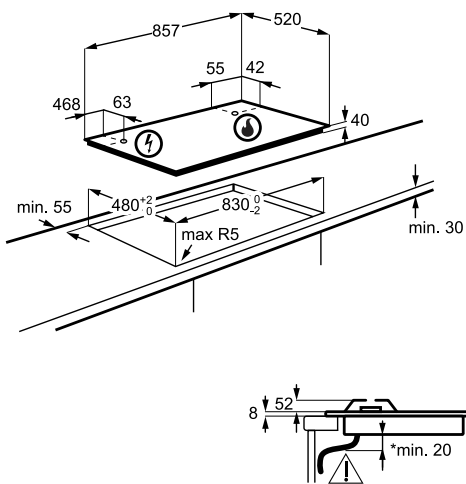

HVB75450IB

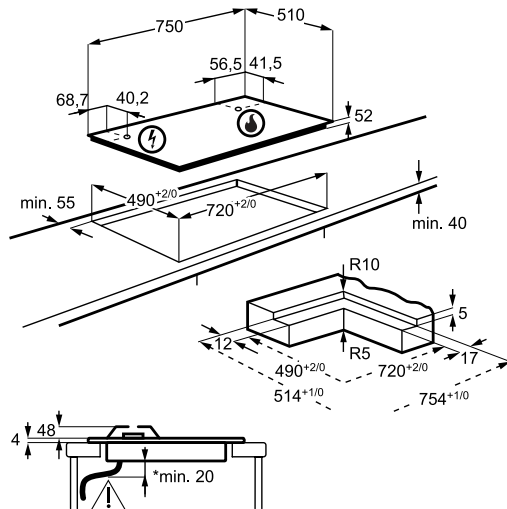

HKB75450NB

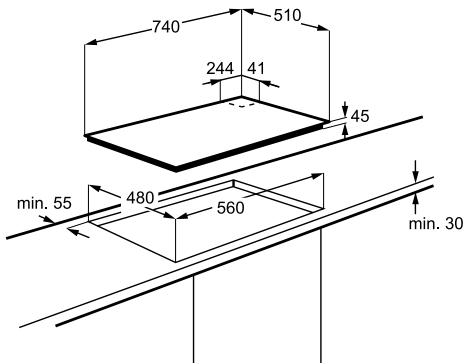

HGB75420YM

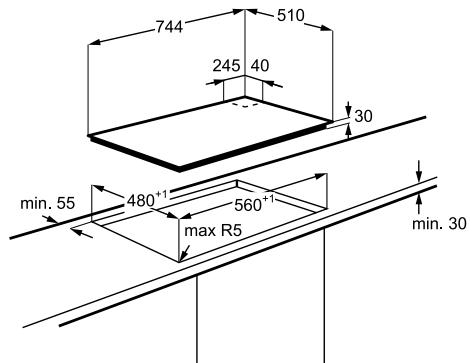

HKB64450NB

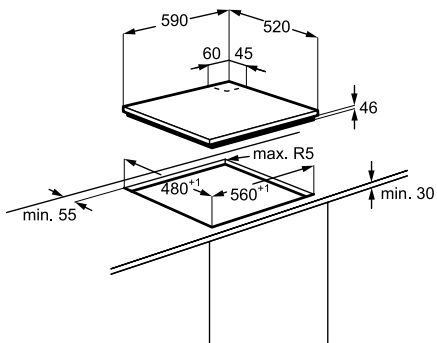

HGB64420YM

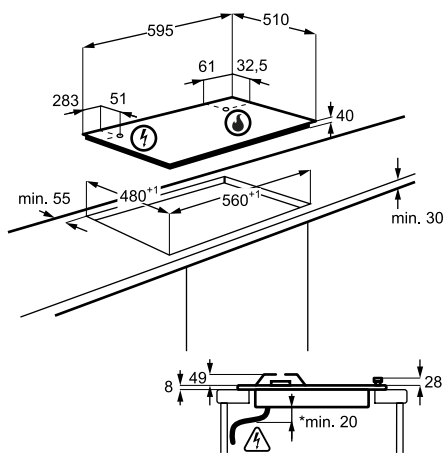

MIXED FUEL HOB

HD955100NB

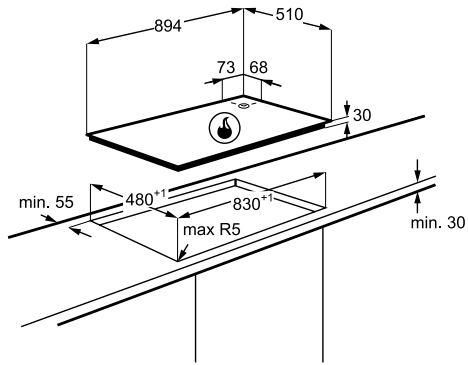

MODULAR HOB

IKE42640KB

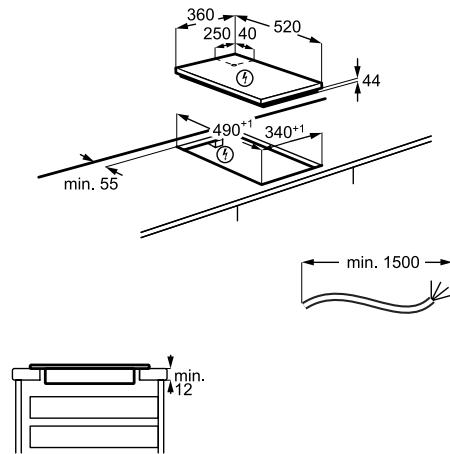

DESIGNER HOODS

DLE0970M

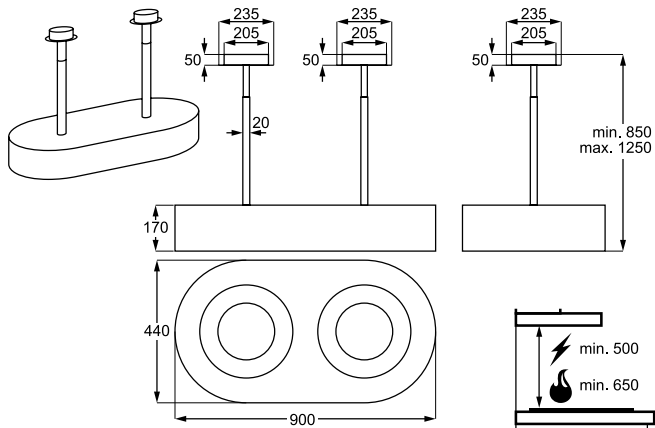

DLE0630B/W

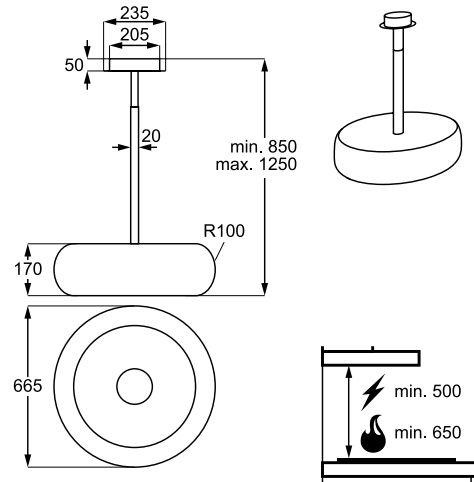

DLE0431W/B/M

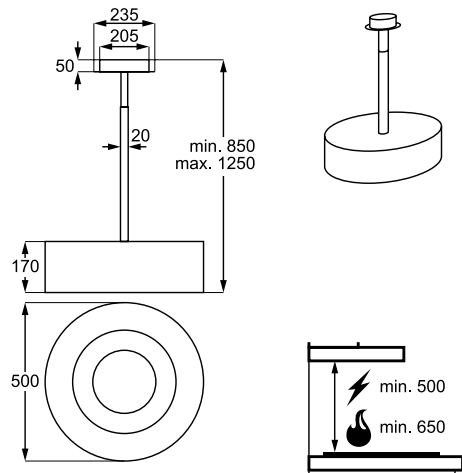

HOODS

DIK6180HG

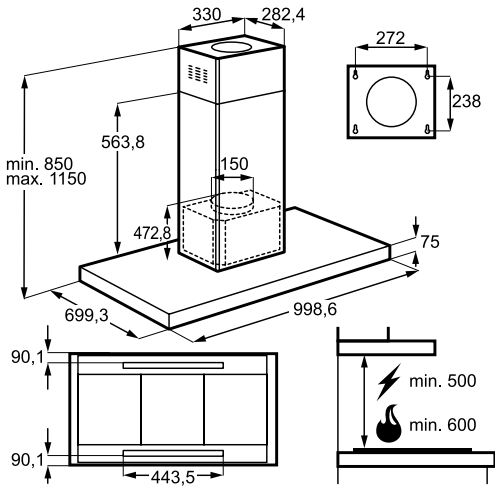

DIE5961HG

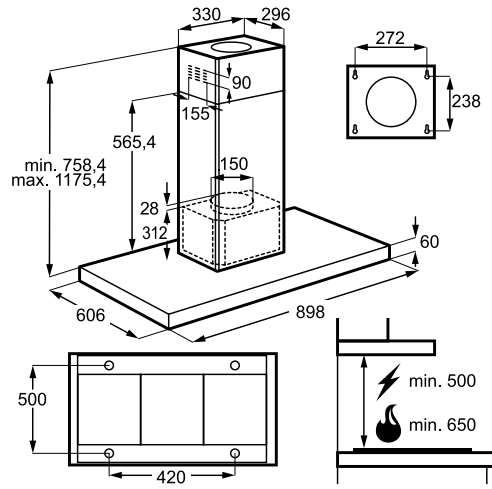

DDE5980G

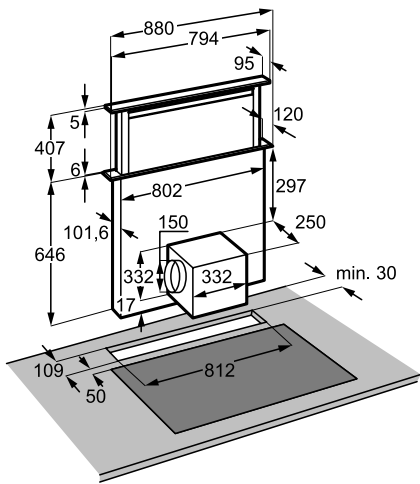

DCK5281HG

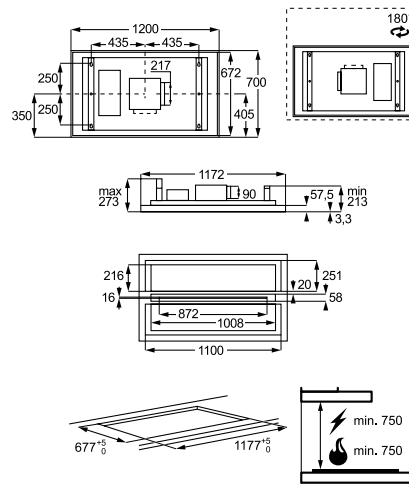

DCE5960HM

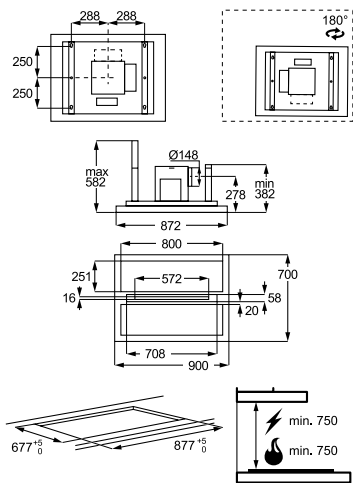

DVK6981HR

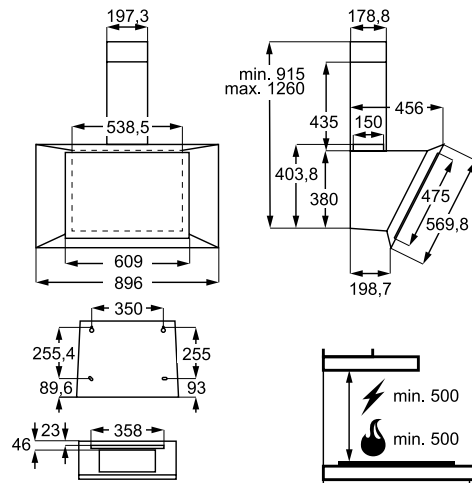

DVE5971HG

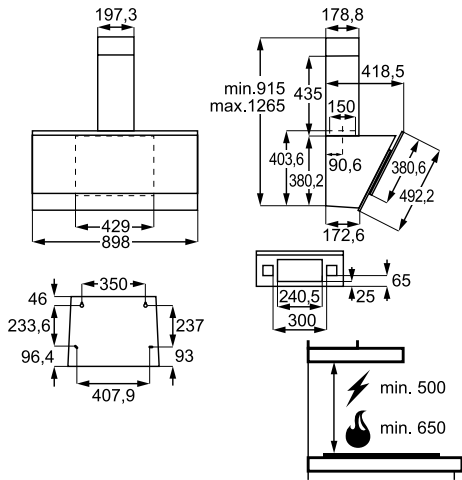

DKB4950M, DKB4650M

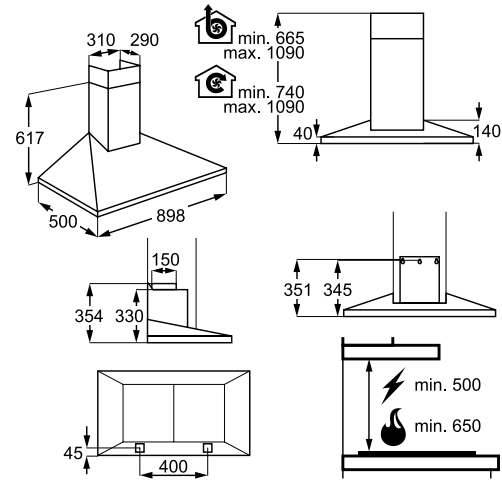

DVE5671HG

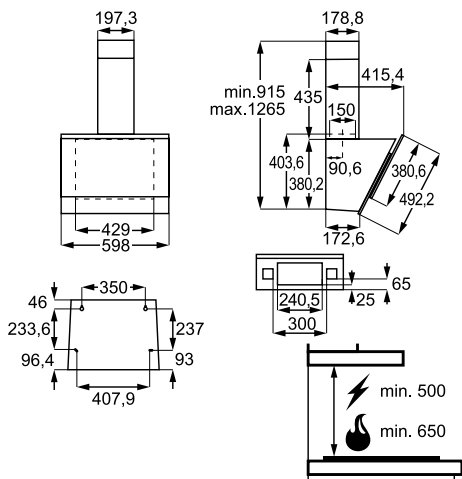

DBK6980HG

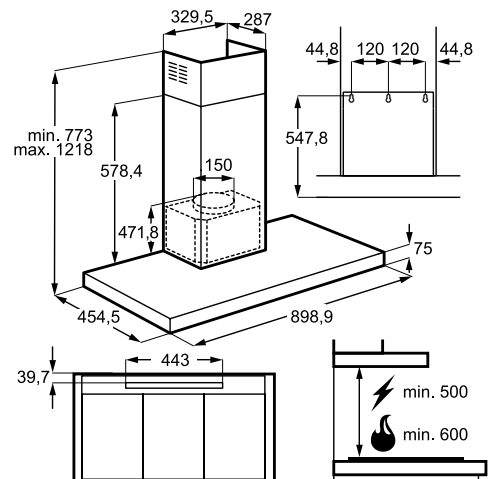

DBK6680HG

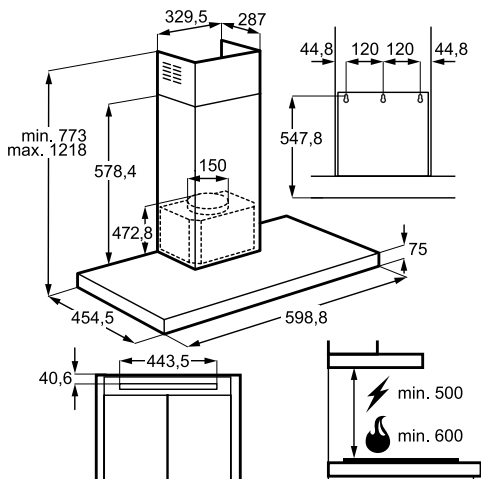

DBE5961HG/DBE5761HG/DBE5661HG

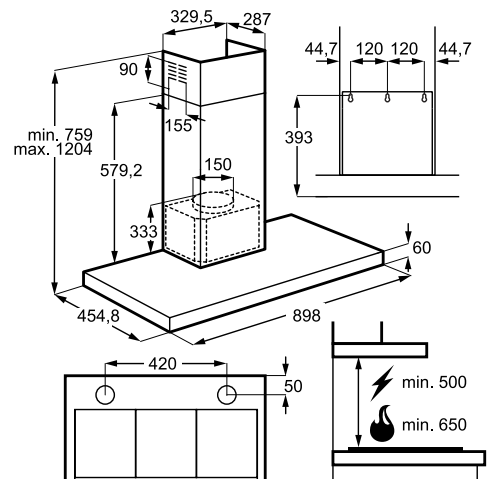

HOODS

DGE5861HM, DGE5861HB

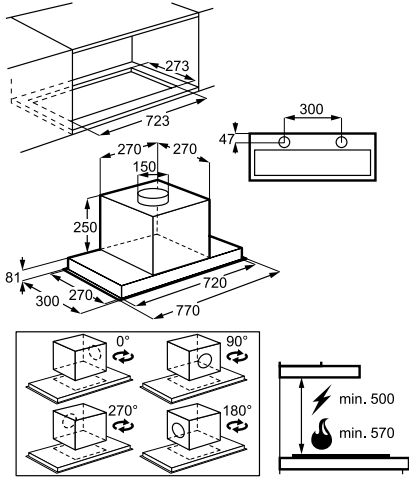

DPB3632S

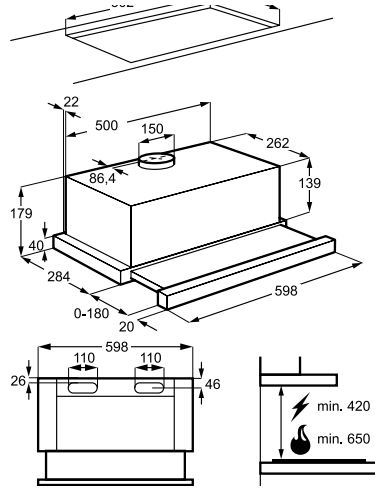

DGE5661HM, DGE5661HB

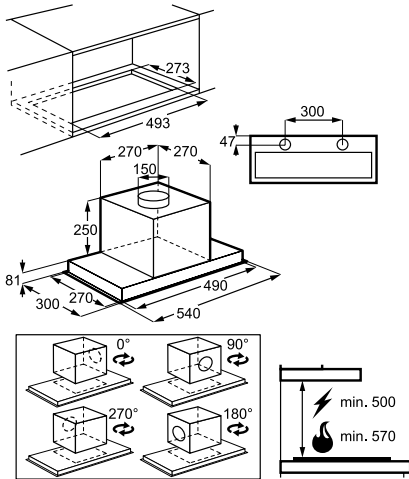

DPB3932S

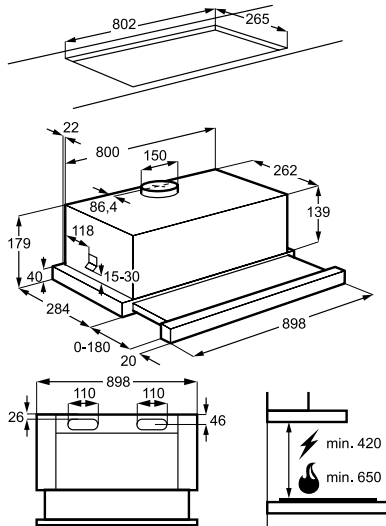

DGB3850M

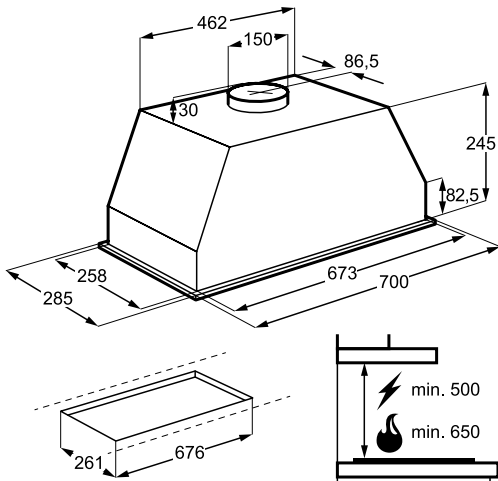

DEB2631S

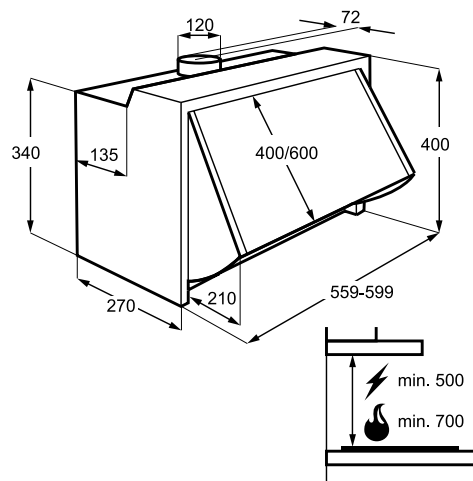

DISHWASHERS

FSK93847P, FSE83837P, FSE74747P, FSK75757P, FSS63607P FULLY INTEGRATED

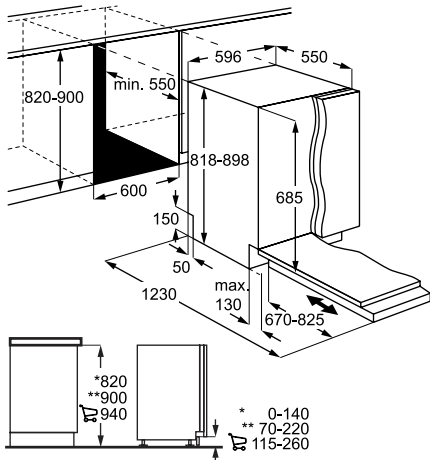

FSE72507P SLIMLINE INTEGRATED

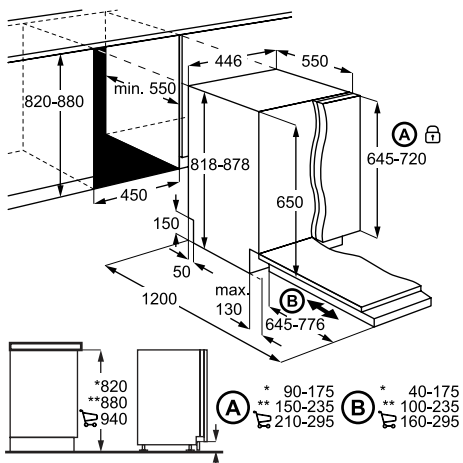

FSK52917Z, FSB42607Z FULLY INTEGRATED

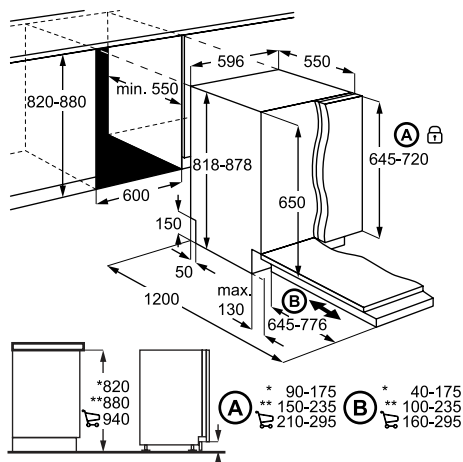

LAUNDRY

L7FC8432BI, L7WC8632BI

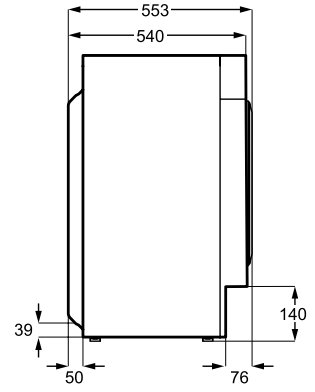
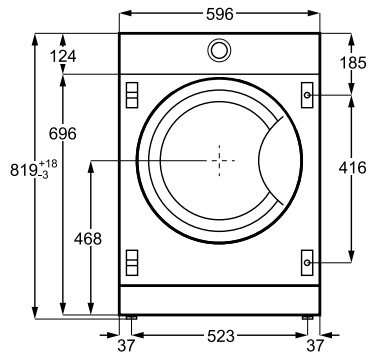
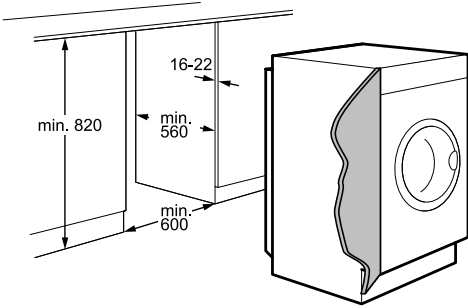

ENERGY INFORMATION

UK & EUROPEAN EFFICIENCY SCALE

This scheme, which covers refrigerators, freezers, wine coolers, washing machines, washer dryers and dishwashers is designed to offer you a standardised method of choosing the most energy efficient appliances. For washer dryers, the label will scale separately washing & drying, and washing.

Energy Label for customers in
England, Scotland and Wales

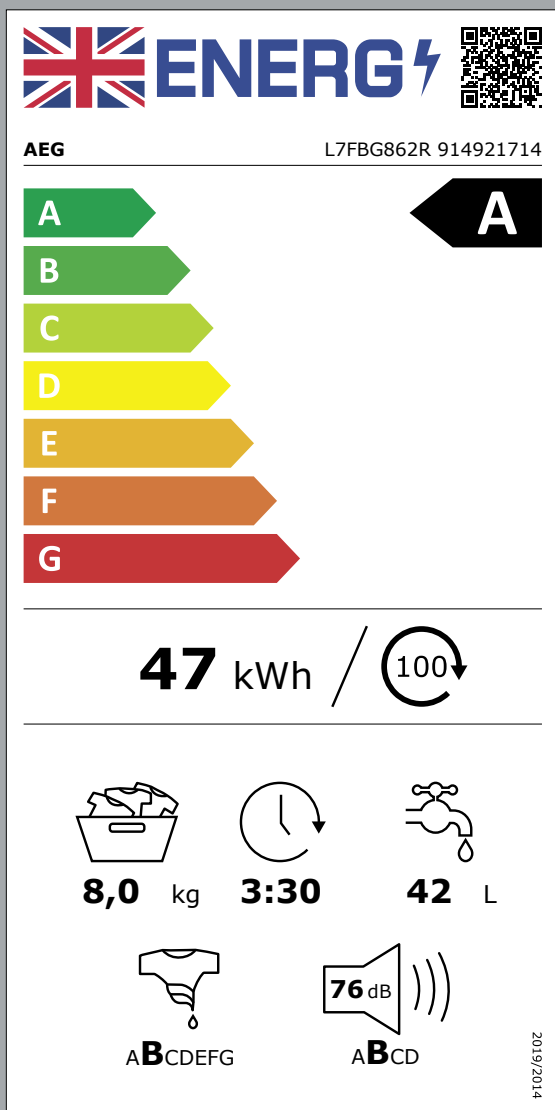

Energy Label for customers in
Republic of Ireland and Northern Ireland

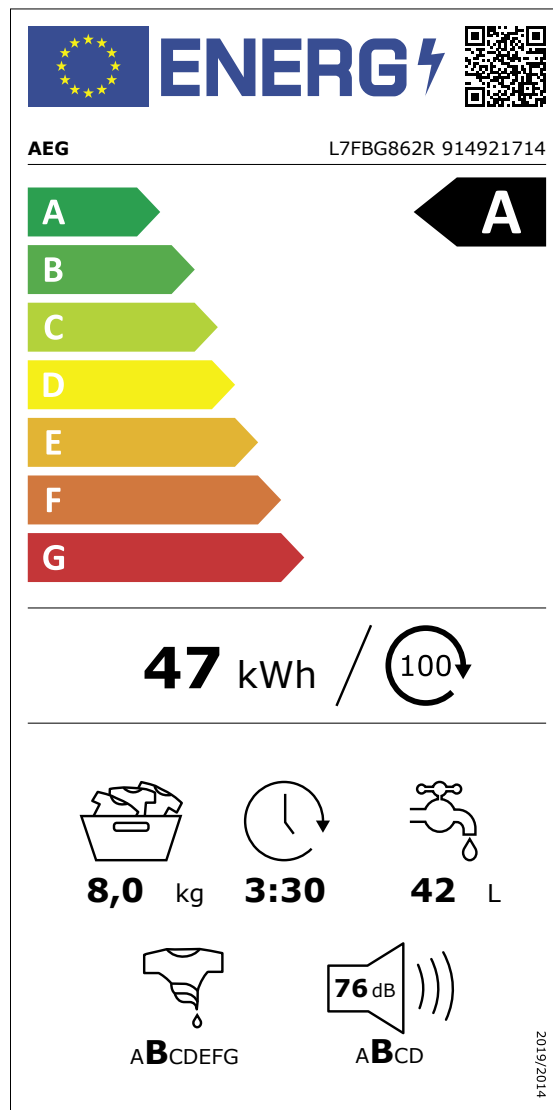

AFTER SALES SUPPORT & CUSTOMER CARE

Customer Service

Should you need to contact us about your product we have a dedicated AEG customer service team to help. Our team is based in the AEG UK head office and can be contacted by phone on **03445 611 611** or via **aeg.co.uk**

Local service, nationwide

Our national network of Service Force agents provide product maintenance, genuine parts and repairs for all AEG Major Appliances. Genuine AEG parts ensure you continue to experience the excellent performance you expect from your AEG product.

If you require a visit from one of our agents for your Major Appliance please call our Service Force team on **03445 616 616**.



AEG Major Appliances
Addington Way
Luton LU4 9QQ

Telephone: **03445 611 611**

AEG Major Appliances is a division of Electrolux plc.
Registered in England, No. 2331516.
Registered Office, Addington Way,
Luton LU4 9QQ

AEG Major Appliances
Electrolux Group Ireland Ltd
Suite 7 & 8 Westland House,
Westland Business Park,
Nangor Road,
Dublin 12 D12 TR98

Tel: **00353 (0)818 543000**

Registered in Ireland No 9118.
Registered Office:
Nangor Road,
Dublin 12 D12 TR98



AEG

AEG

8000 SERIES | LAVATHERM
AbsoluteCare System

AEG

Premier Partner

We are AEG.

We exist to redefine what you expect out of your household appliances, which is why we want to challenge the boundaries of everyday life.

Since our start in Berlin in 1887, we've never settled for good enough. And we don't think you should have to either.

That's why we never compromise with innovations for your home. We believe in responsible innovations that stand out today and help build a better tomorrow. So you can live on your own terms while also living up to the terms of the environment.

CHALLENGE THE EXPECTED