

Nicoleta Popescu, Cristina Martin



Caiet de scriere

pentru

clasa pregătitoare



• **semne grafice**

• **litere și cifre**

NUME și PRENUME:

CLASA:

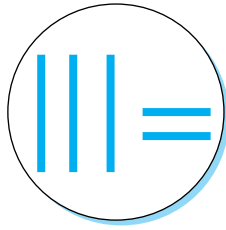
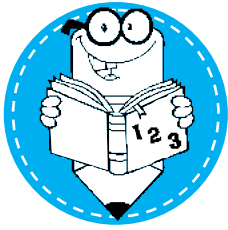

Linia verticală și linia orizontală

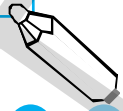

Trasează liniile după model. Poți folosi culori diferite.

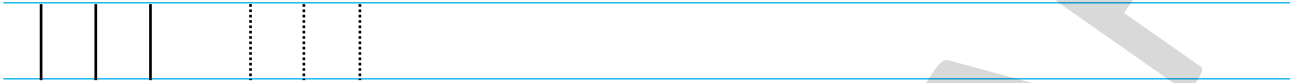

NE JUCĂM ȘI EXERSĂM! Unește punctele, apoi colorează desenele.

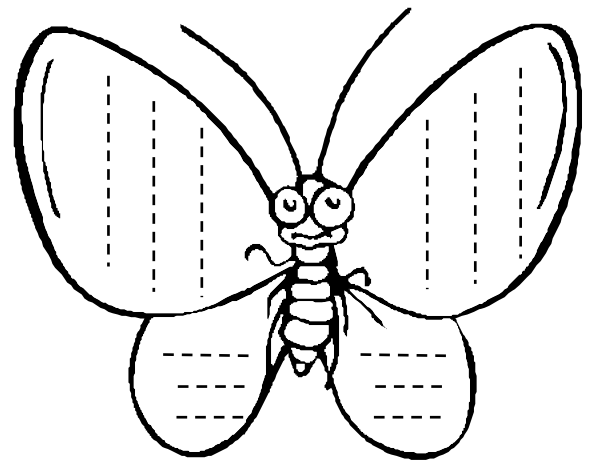
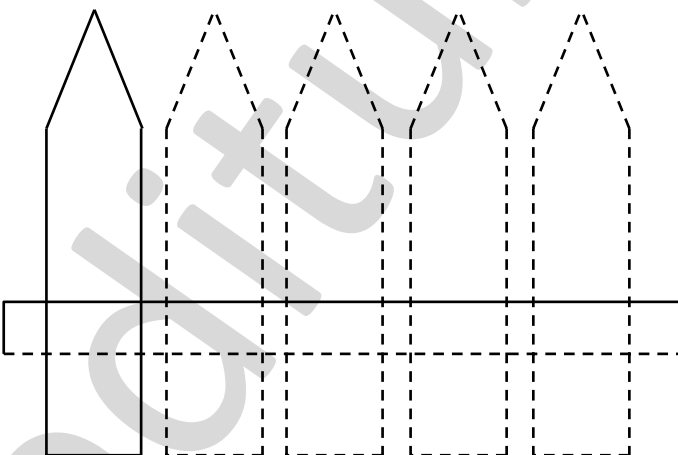
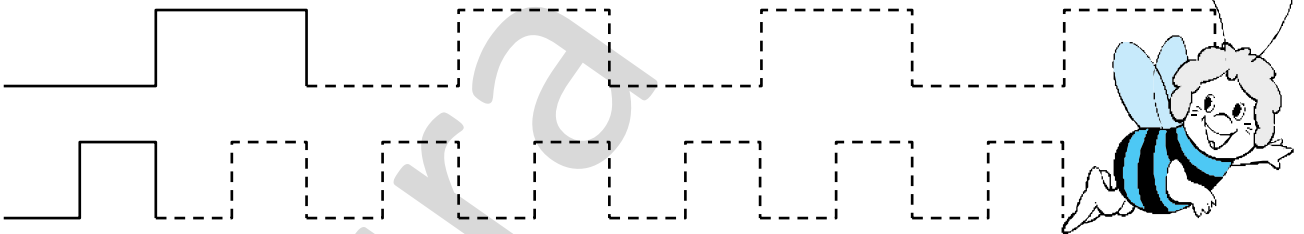

Cum ai desenat?
Colorează chipul potrivit!



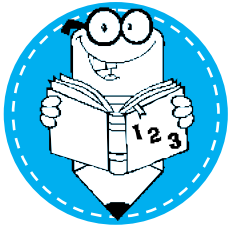

Linia oblică

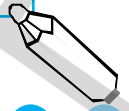

Trasează liniile oblice după model.



NE JUCĂM ȘI EXERSĂM! Unește punctele și trasează liniile oblice. Poți folosi culori diferite. La sfârșit, autoevaluează-te!

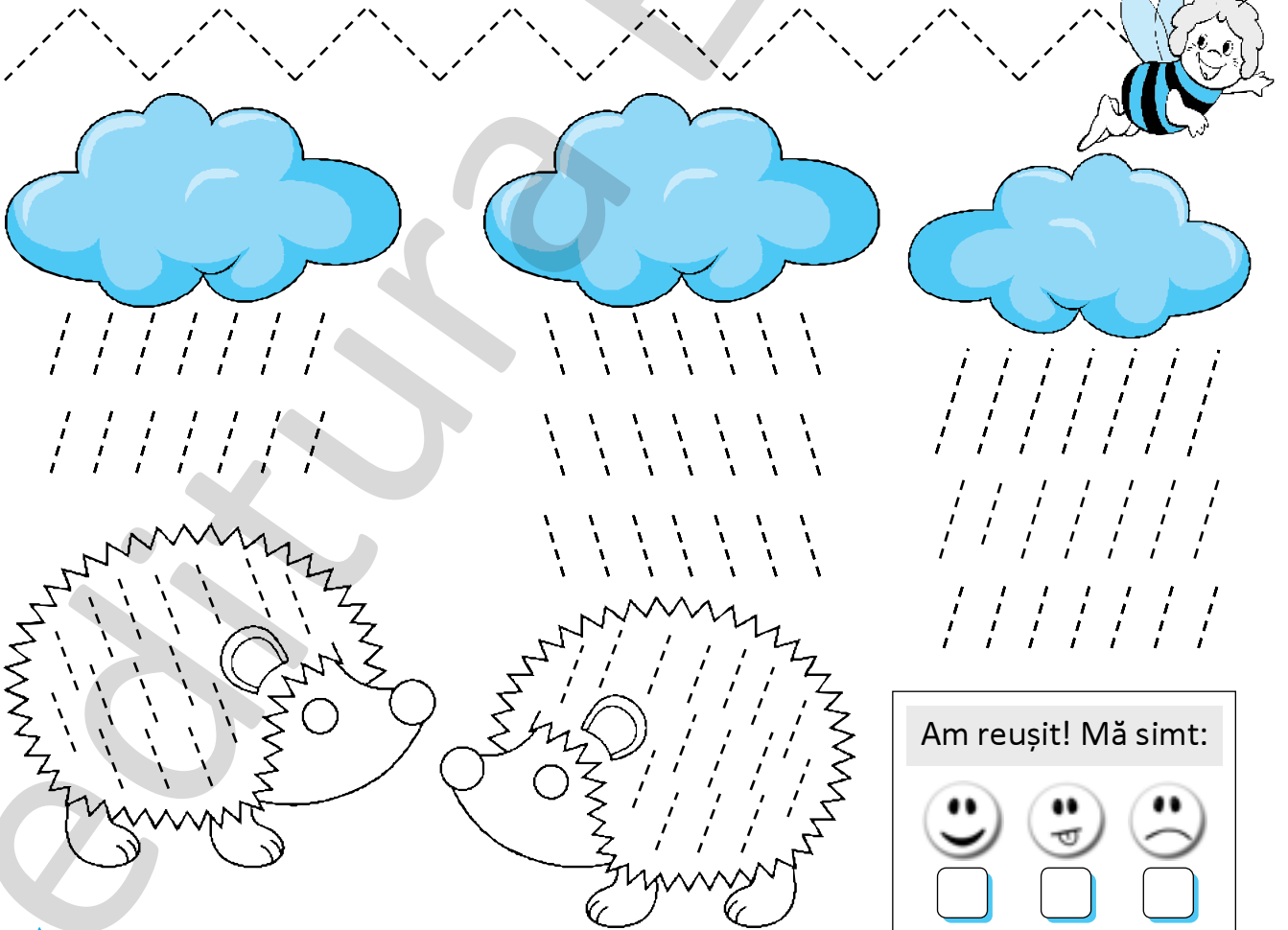

Am reușit! Mă simt:



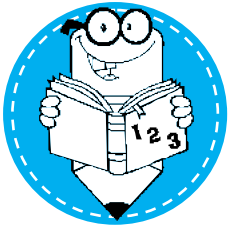

Cârligul

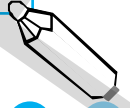

● Trasează cârligul după model.



● NE JUCĂM ȘI EXERSĂM! Unește punctele pentru a completa desenele. Colorează!

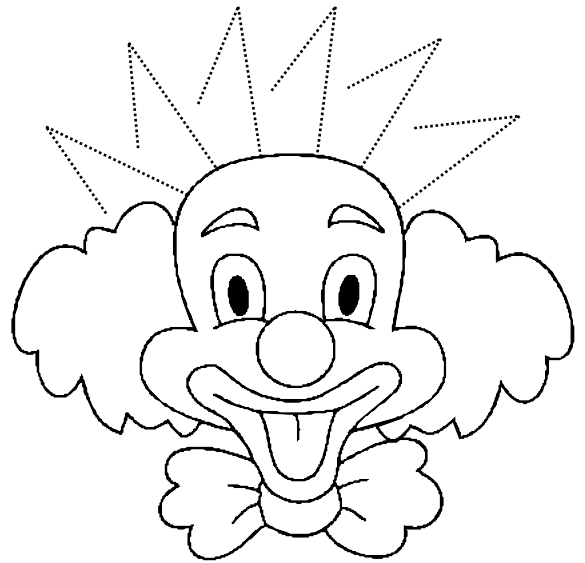
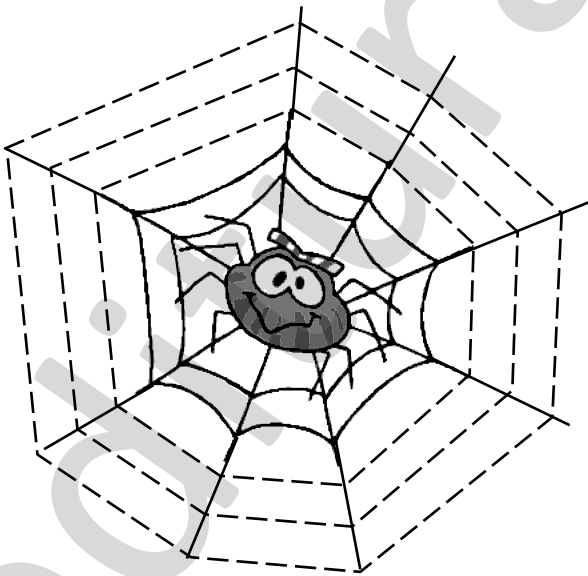
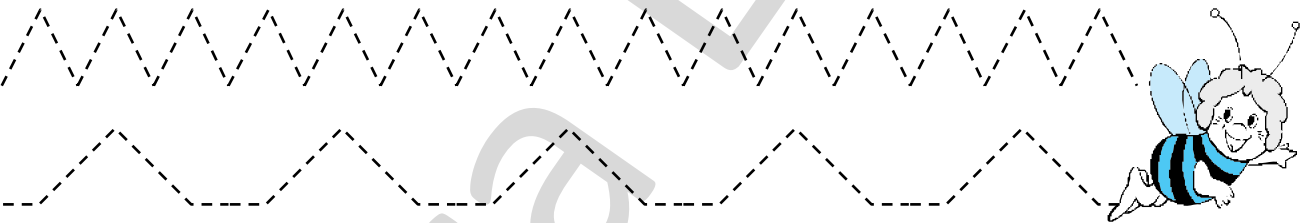

Cum ai desenat?
Colorează chipul potrivit!



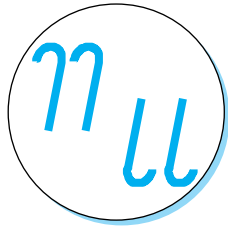
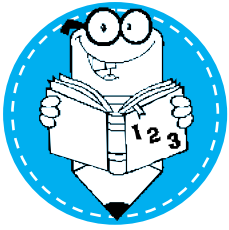

Bastonașul

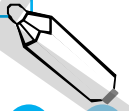

Trasează bastonașul după model.

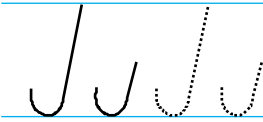
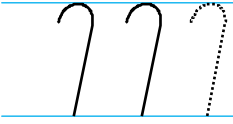

NE JUCĂM ȘI EXERSĂM! Unește punctele pentru a continua desenele. Roagă-l pe colegul de bancă să denumească imaginile. Colorează! La sfârșit, autoevaluează-te!

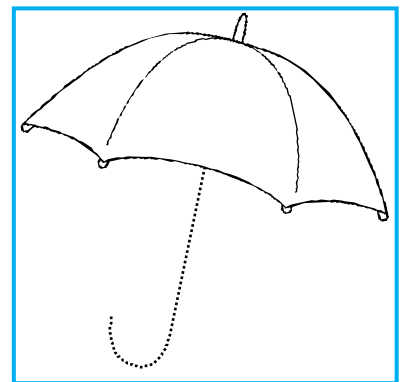
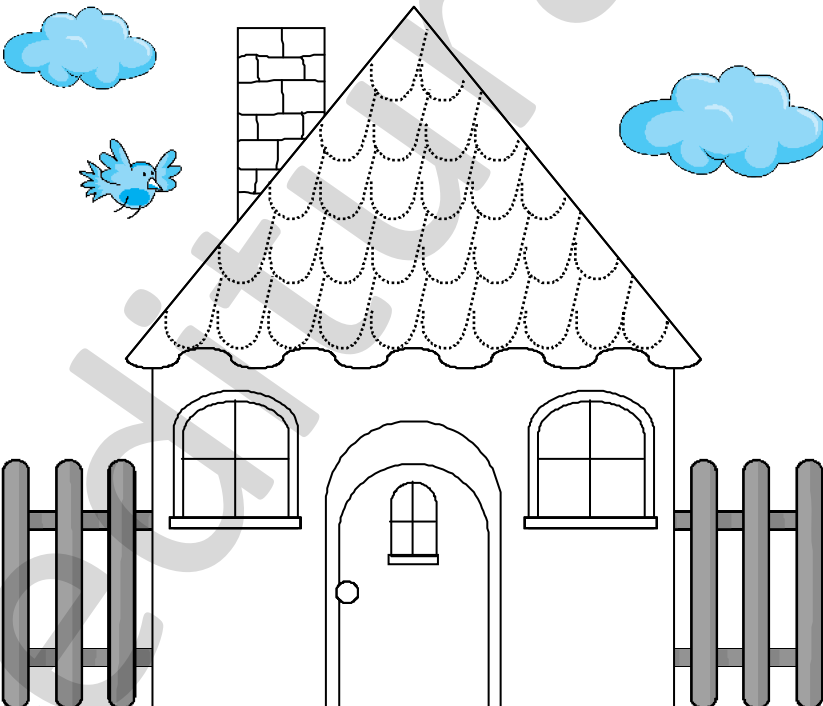
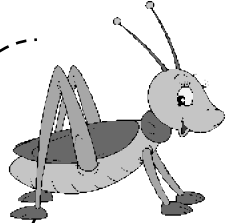

Am reușit! Mă simt:



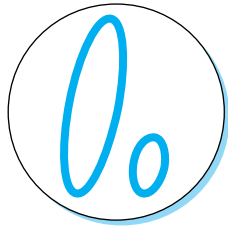
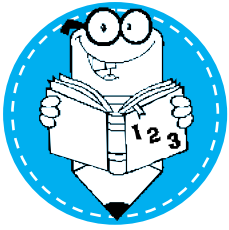

Ovalul

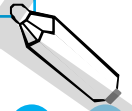

● Trasează ovalele după model.

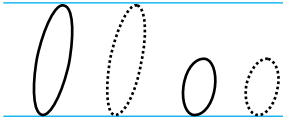
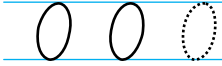
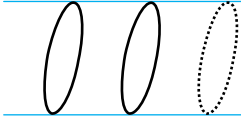

● NE JUCĂM ȘI EXERSĂM! Desenează ouăle găinii. Câte ai numărat?

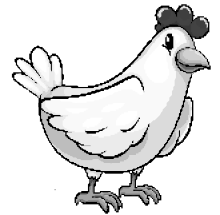

● NE JUCĂM ȘI EXERSĂM! Unește punctele pentru a completa desenul. Colorează-l!

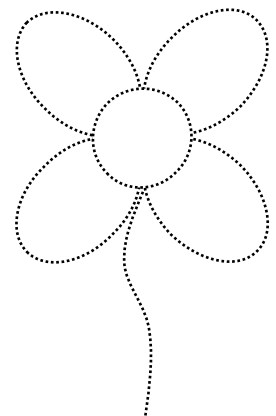
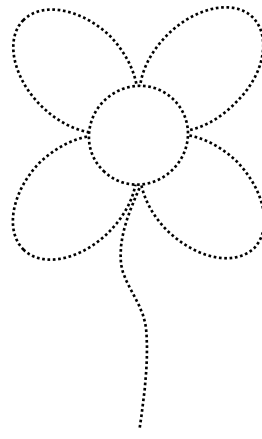
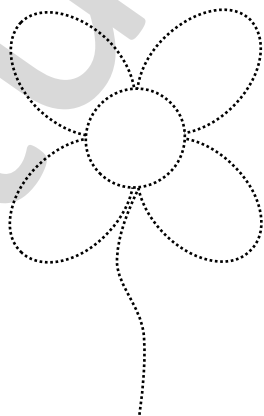
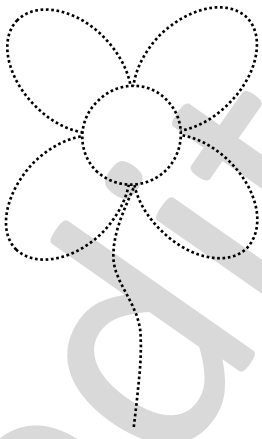

● POȚI ȘI TU! Adăugă frunze florilor. Colorează-le cu verde.

Am reușit! Mă simt:



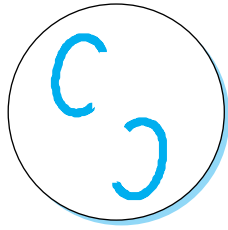
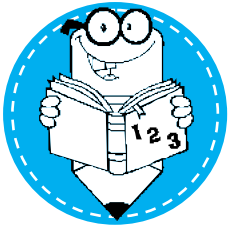

Semiovalul

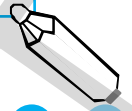

● **Trasează semiovalul după model.**

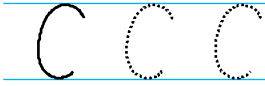

● **NE JUCĂM ȘI EXERSĂM!** Unește punctele pentru a finaliza desenele. Colorează corespunzător! La sfârșit, autoevaluează-te!

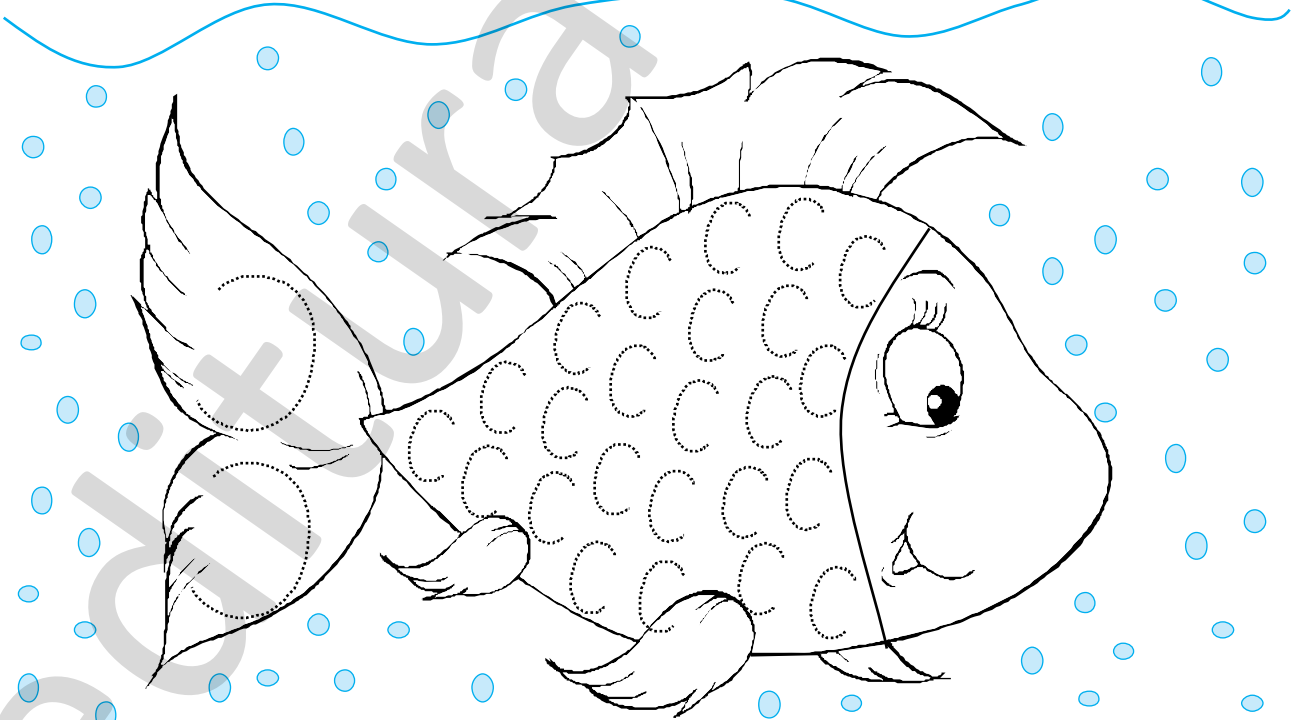
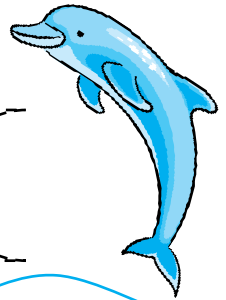
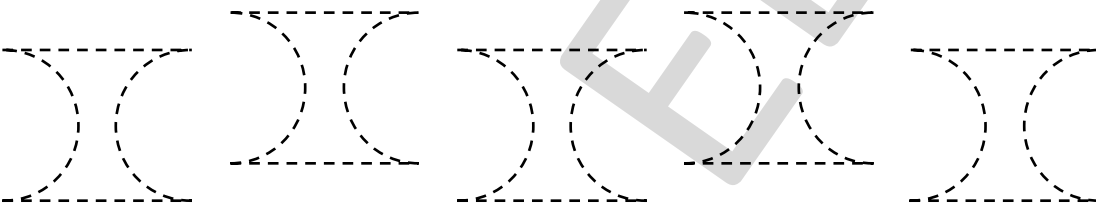

Am reușit! Mă simt:



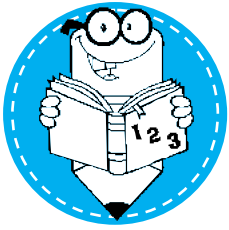

Zala

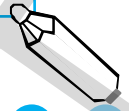

● Trasează zala după model.

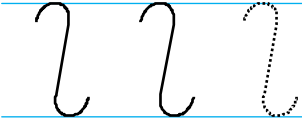

● **NE JUCĂM ȘI EXERSĂM!** Unește punctele pentru a finaliza desenele. Decorează vaporul cu alte elemente grafice învățate.

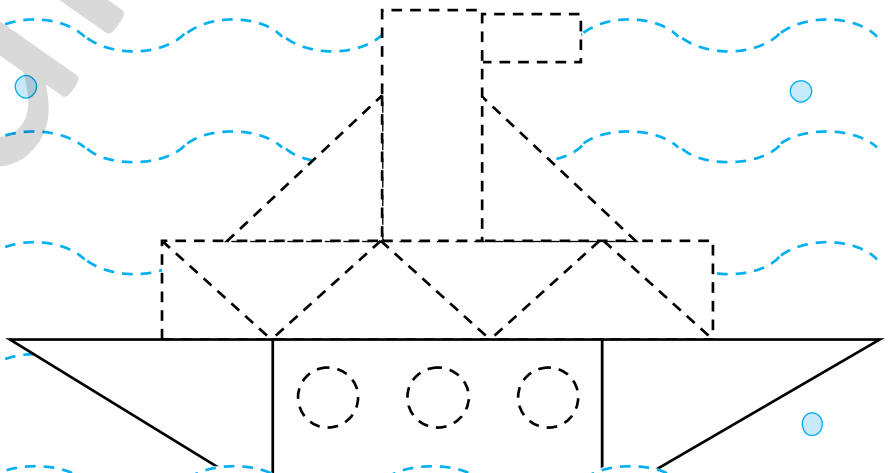
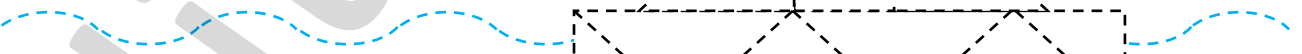
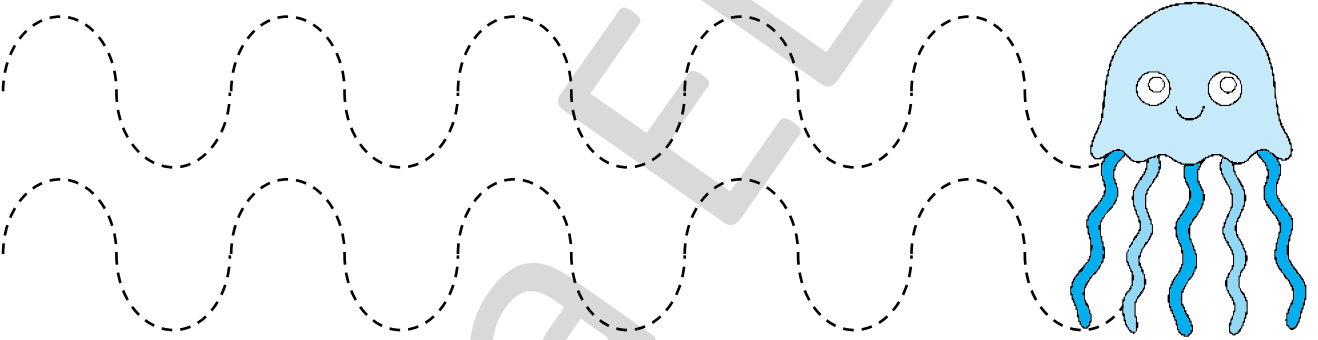

Roagă-l pe colegul de bancă să te evalueze!



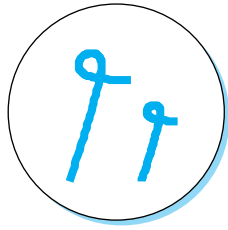
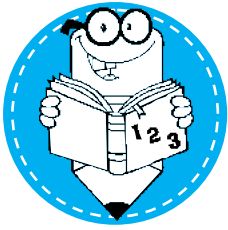

Nodulețul



● Trasează nodulețul urmărind modelul.

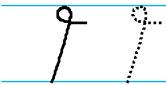
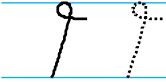

● NE JUCĂM ȘI EXERSĂM! Unește punctele fără a ridica stiloul.

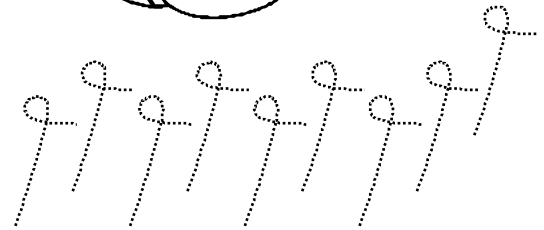
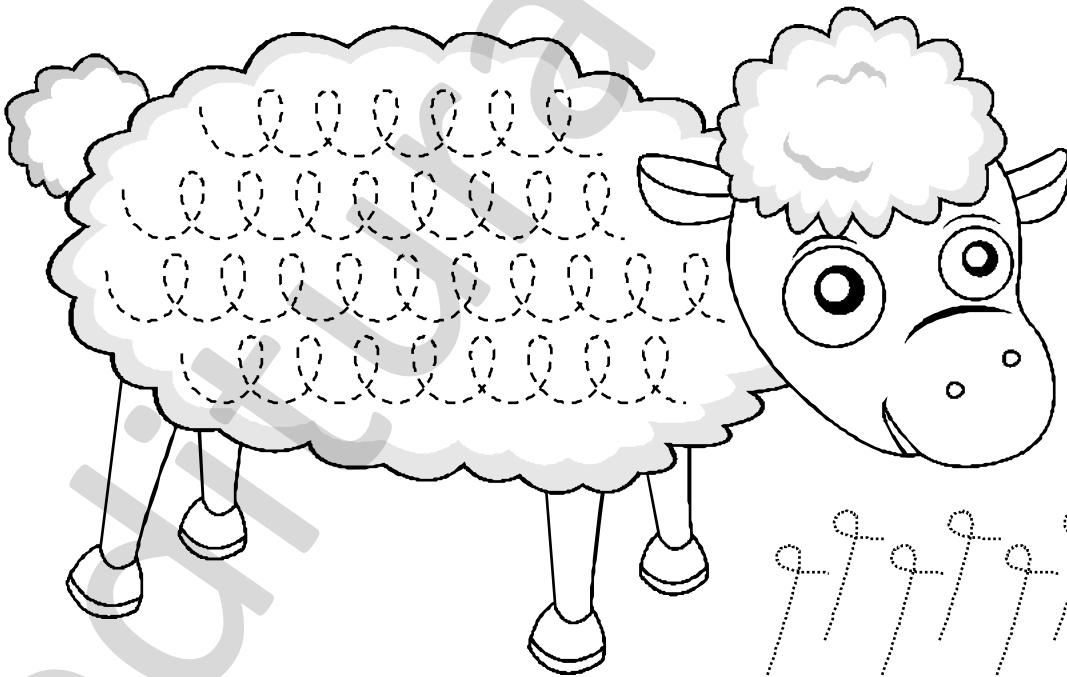
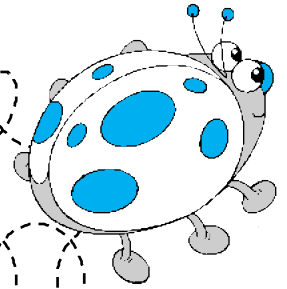

● Roagă-l pe colegul de bancă să dea un nume oiței.

Am reușit! Mă simt:



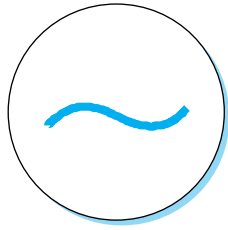
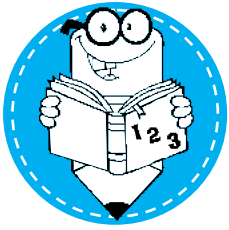

Linia șerpuită

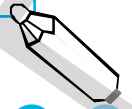

Trasează după model. Folosește diferite instrumente de scris.

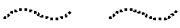

NE JUCĂM ȘI EXERSĂM! Unește punctele ca să completezi desenele! Decorează melcul folosind culori diferite pentru semne diferite. Adaugă fire de iarbă, din hârtie glasăță verde.

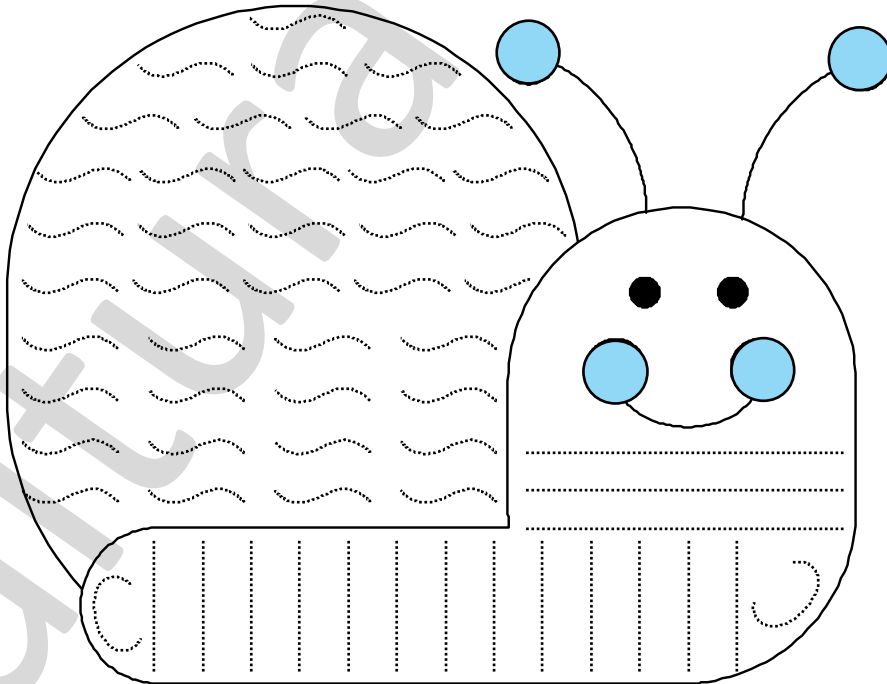
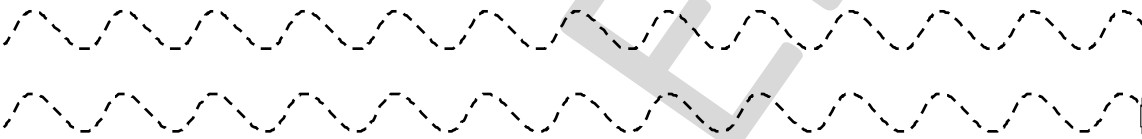

Cum ai desenat?
Colorează chipul potrivit!



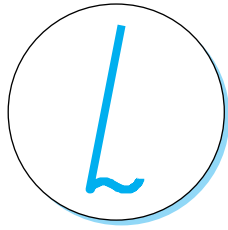
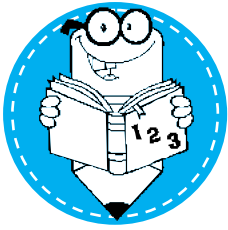

Biciul

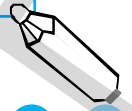

Trasează biciul după model.

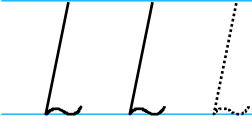

NE JUCĂM ȘI EXERSĂM! Unește punctele, apoi colorează desenele.
Completează corpul omizii cu încă un element, pe care îl vei decora cum dorești.

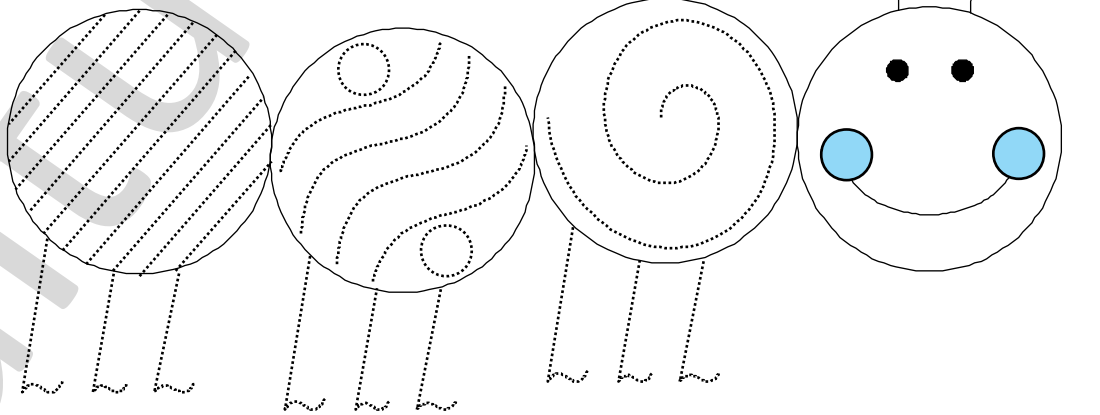
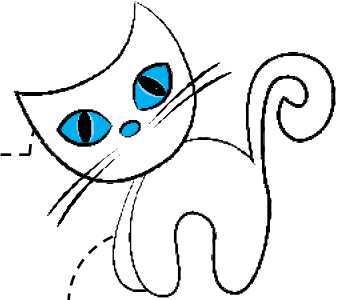
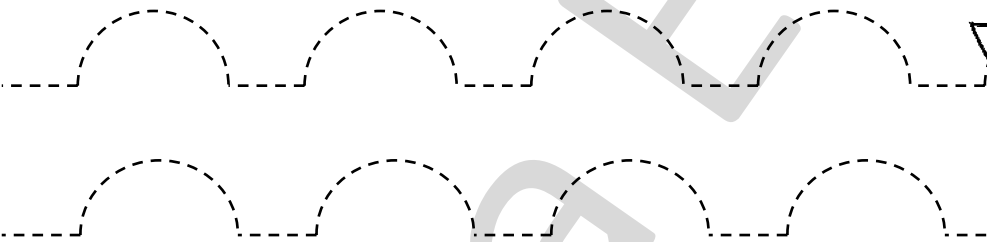

Cum ai desenat?
Colorează chipul potrivit!



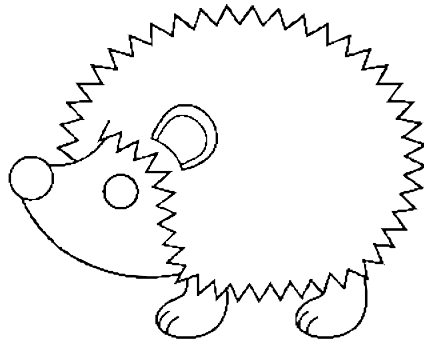

Desenează-i țepi
ARICIULUI!

- Recunoaște și încercuiește literele „A” și „a” în cuvintele care denumesc imaginile de mai jos.
- Colorează cu galben imaginea care reprezintă o insectă și cu verde imaginea care reprezintă o legumă.



ALBINĂ

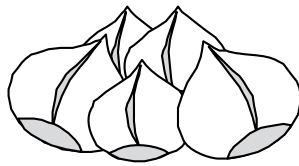

ALUNE



ARDEI

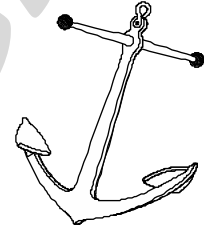

ancoră

- Trasează litera după model.

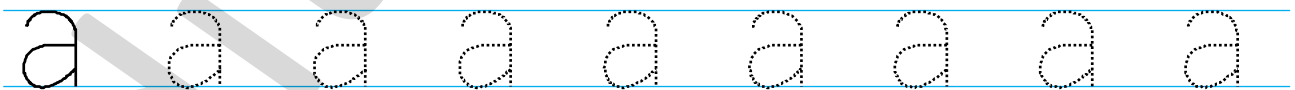
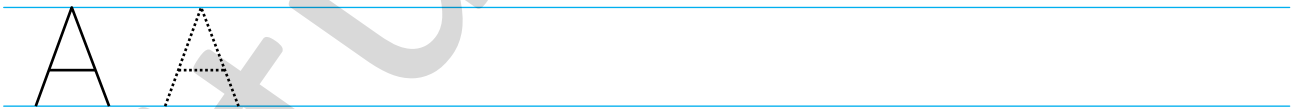
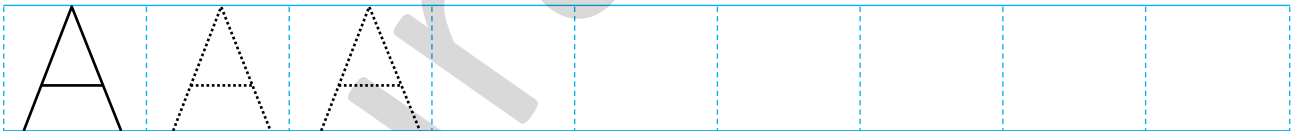
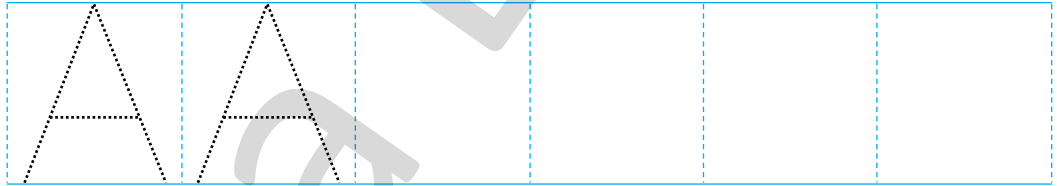
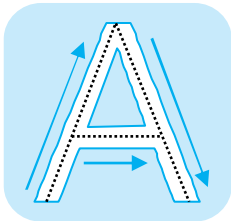

- FII CREATIV!** Desenează ARICIUL pe o foaie de hârtie. În loc de țepi, scrie litera „A”. Colorează-l cât mai frumos. Va fi ariciul „AAAA”!

Cum ai scris litera „A”?
Colorează chipul potrivit!



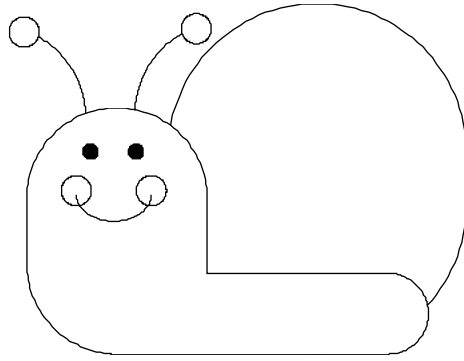

Decorează cochilia
MELCULUI cu
bastonașe!

- Recunoaște și încercuiește literele „M” și „m” în cuvintele care denumesc imaginile de mai jos.
- Colorează cu roșu imaginea care reprezintă un fruct și cu maro imaginea care reprezintă un animal.

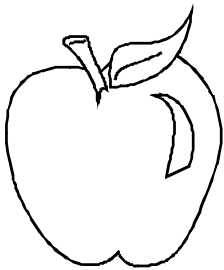

MĂR

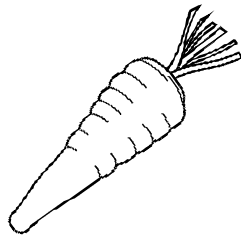

MORCOV



MAIMUȚĂ

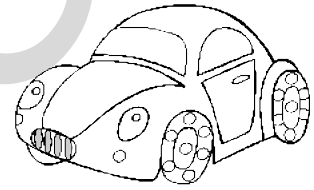

mașină

- Trasează litera după model.

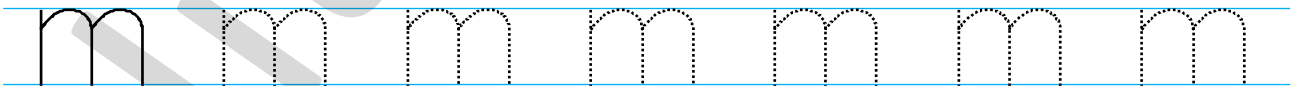
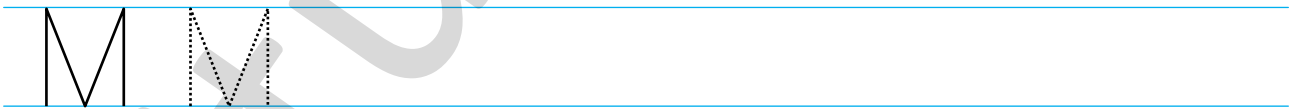
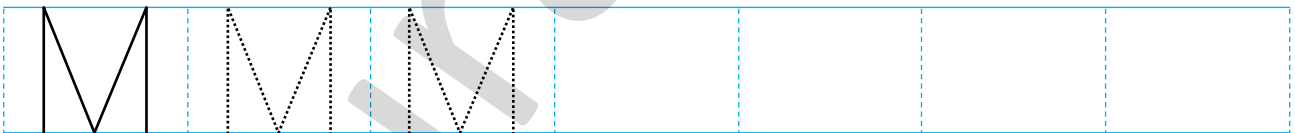
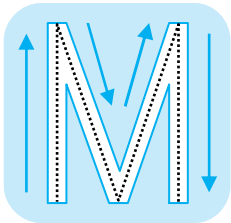

- FII CREATIV!** Desenează melcul de mai sus pe o foaie de hârtie. Decorează-i cochilia cu o mulțime de litere M. Colorează-l cât mai frumos, folosind culori diferite.

Cum ai scris litera „M”?
Colorează chipul potrivit!



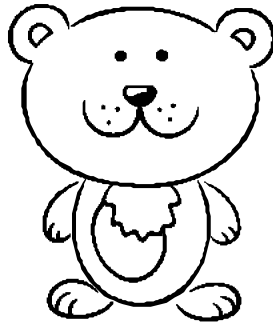

Decorează
URSULEȚUL cu
ovale maro!

● Recunoaște și încercuiește literele „U” și „u” în cuvintele care denumesc imaginile de mai jos.



ULIU



UMBRELĂ

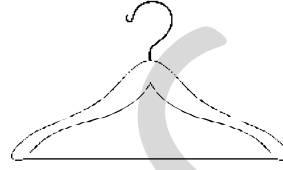

UMERAȘ

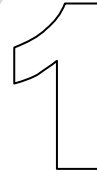

unu

● Trasează litera după model.

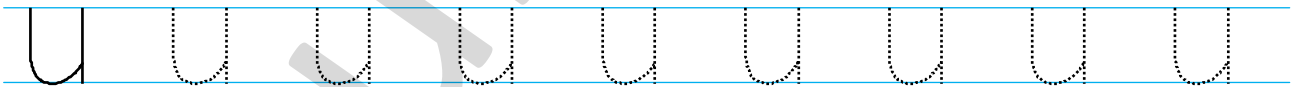
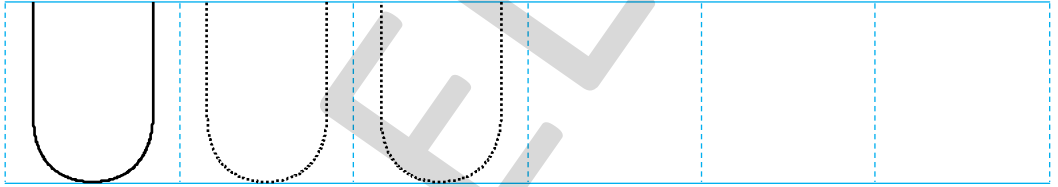
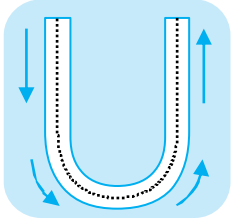

● **POTI ȘI TU!** Învață să desenezi un urs pe o foaie de hârtie, urmărind pașii de mai jos. Ai nevoie doar de o foaie de hârtie și de creioane colorate.

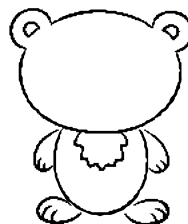
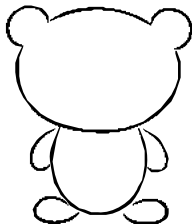
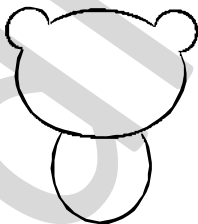

Cum ai scris litera „U”?
Colorează chipul potrivit!



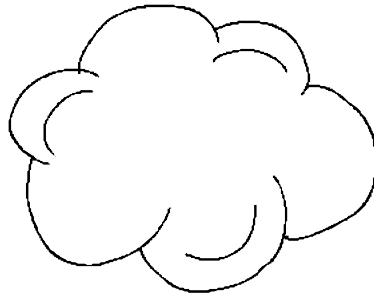
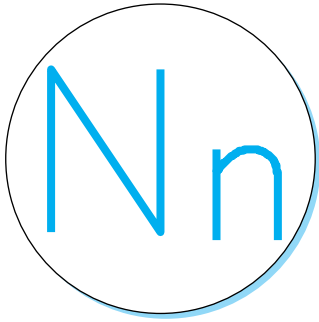

Decorează NORUL
cu ovale albastre!

● Recunoaște și încercuiește literele „N” și „n” în cuvintele care denumesc imaginile de mai jos.



NUCĂ

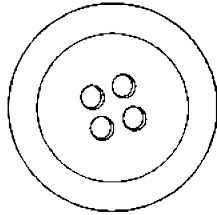

NASTURE

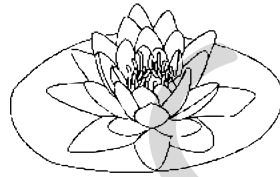

NUFĂR

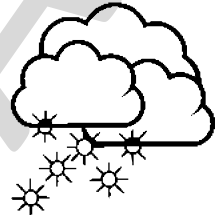

ninsoare

● Trasează litera după model.

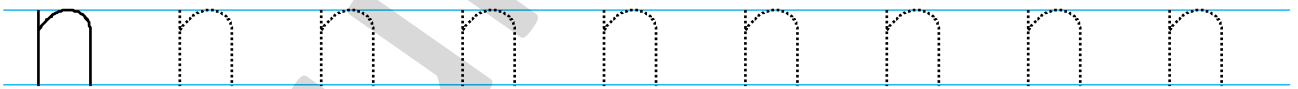
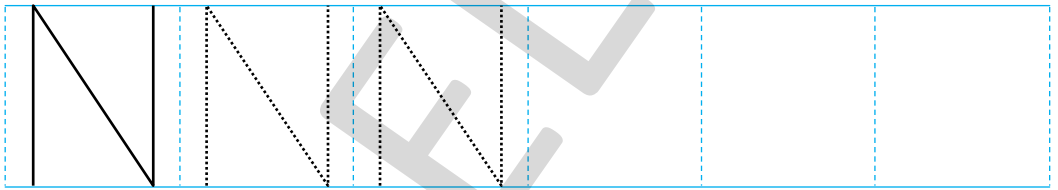
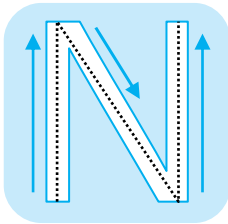

● Exersează! Scrie cuvintele!

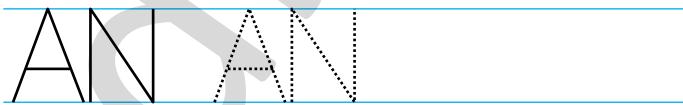
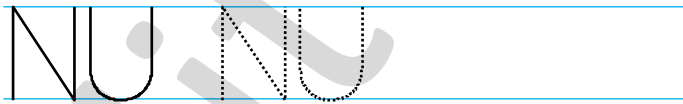

● Desenează un obiect a cărui
denumire conține sunetul „N”.



Cum ai scris litera „N”?
Colorează chipul potrivit!



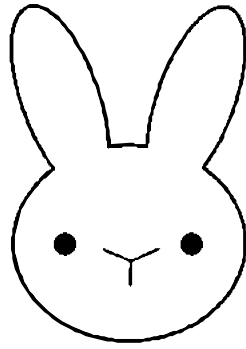
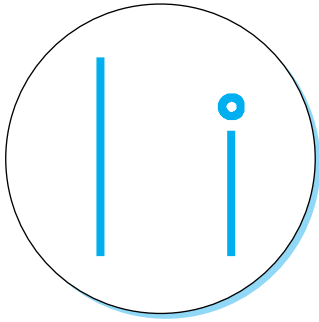

Cu ajutorul liniilor oblice
desenează mustățile
IEPURAȘULUI!

- Recunoaște și încercuiește literele „l” și „i” în cuvintele care denumesc imaginile de mai jos.
- Colorează imaginea care reprezintă o persoană.

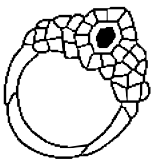

INEL

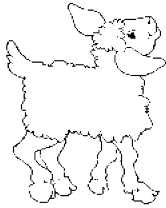

IED



INDIAN

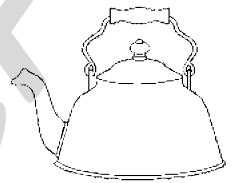

ibric

- Trasează litera după model.

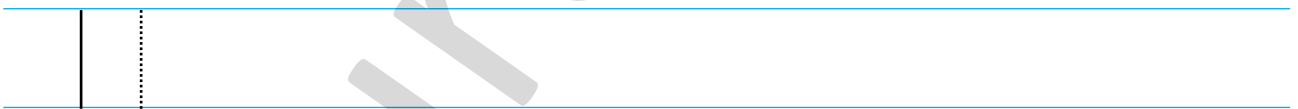
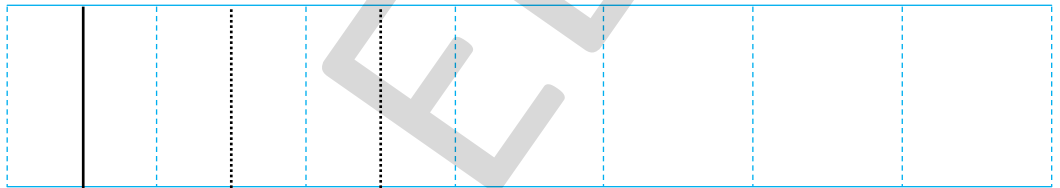
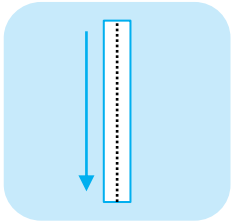

- Exersează! Scrie cuvintele!

INA INA

NINA NINA

Cum ai scris litera „l”?
Colorează chipul potrivit!



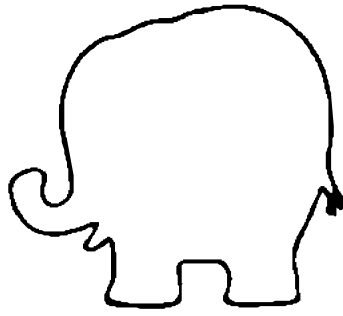

Decorează ELEFANTUL
cu literele învățate!

- Recunoaște și încercuiește literele „E” și „e” în cuvintele care denumesc imaginile de mai jos.
- Colorează imaginea care conține litera „E” de două ori.

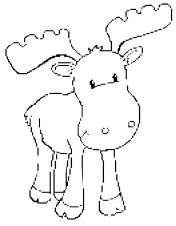

ELAN

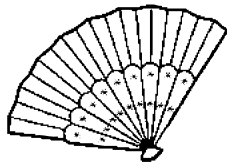

EVANTAI

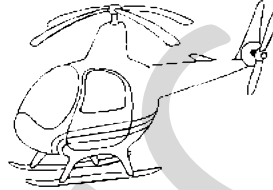

ELICOPTER



explorator

- Trasează litera după model.

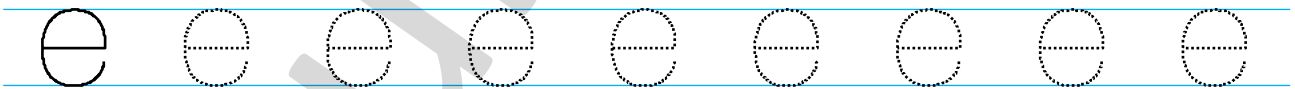
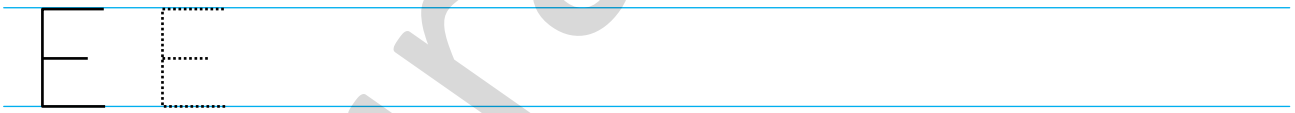
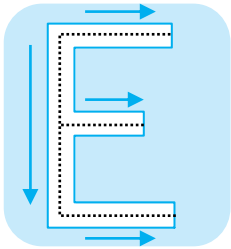

- Unește punctele pentru a obține cuvinte, apoi unește-le cu imaginea potrivită.

ANA

NEN

INIMA

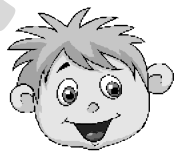

Cum ai scris litera „E”?
Colorează chipul potrivit!



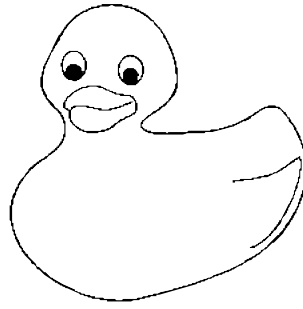

Decorează
RĂTUȘCA cu
bastonașe!

● Recunoaște și încercuiește literele „R” și „r” în cuvintele care denumesc imaginile de mai jos.

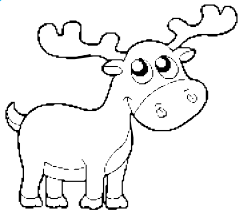

REN

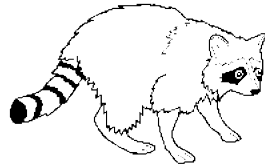

RATON

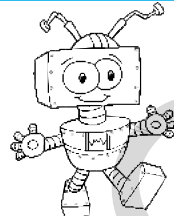

ROBOT



rac

● Trasează litera după model.

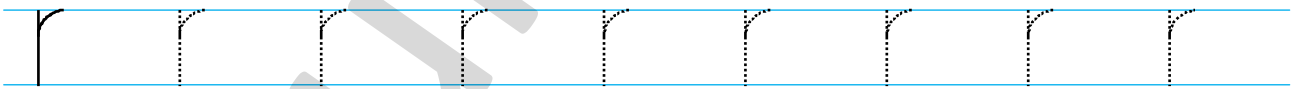
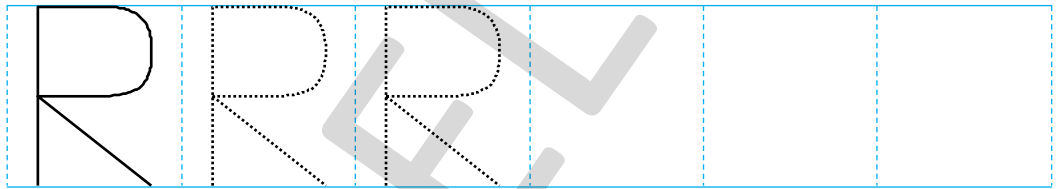
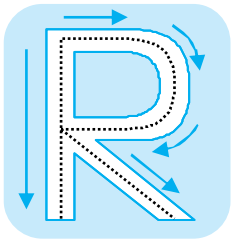

● Completează spațiile libere cu litera R și citește cuvintele obținute.

MA _ IA

MA _ E

● Desenează o imagine a cărei denumire conține litera „r” și are două silabe.

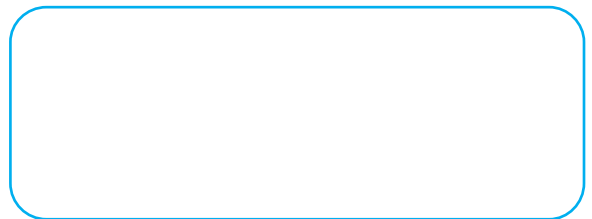

Cum ai scris litera „R”?
Colorează chipul potrivit!



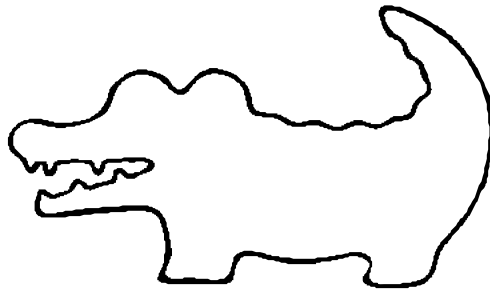
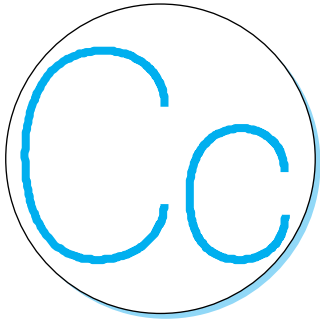

Decorează
CROCODILUL cu
semiovale!

● Recunoaște și încercuiește literele „C” și „c” în cuvintele care denumesc imaginile de mai jos.

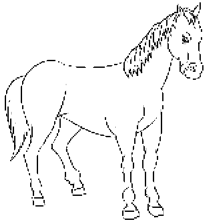

CAL

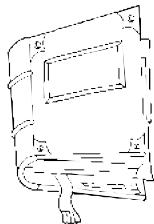

CARTE



CORN

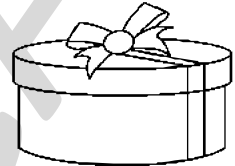

cadou

● Trasează litera după model.

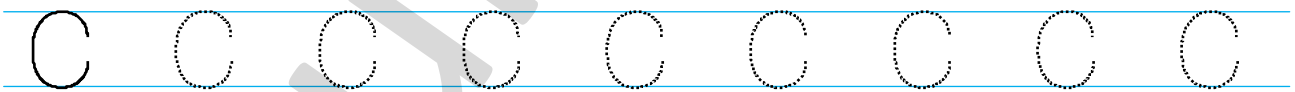
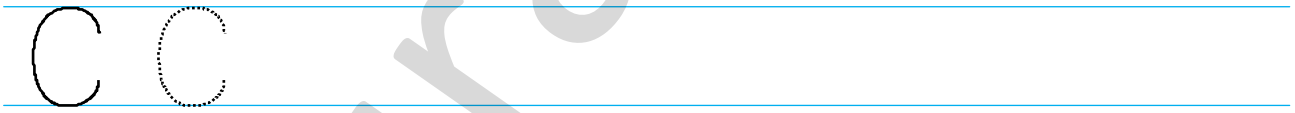
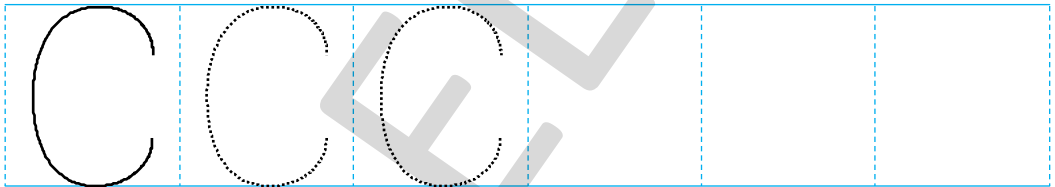
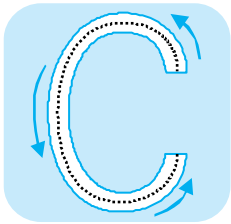

● Exersează!

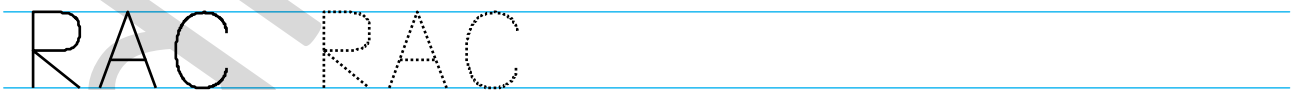

● **FII CREATIV!** Pe o coală de hârtie transformă litera „C” în ceva amuzant: desenează-i „ochi”, „mâini” etc.

Cum ai scris litera „C”?
Colorează chipul potrivit!



Numărul și cifra 1

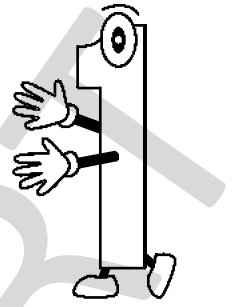
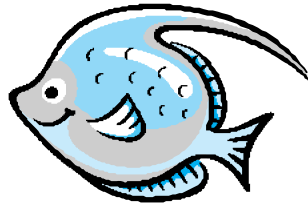

● *Scrive cifra după model!*

1	1	1	1																
1	1																		
1																			

1	1	1																	
1	1																		
1																			

● *Colorează un element din fiecare mulțime.*

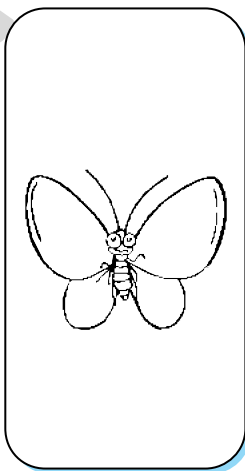
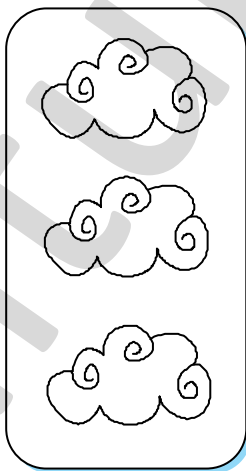
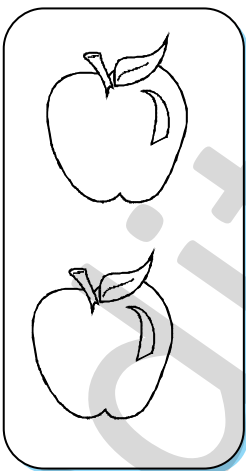

● *Decorează cu puncte cifra 1!*

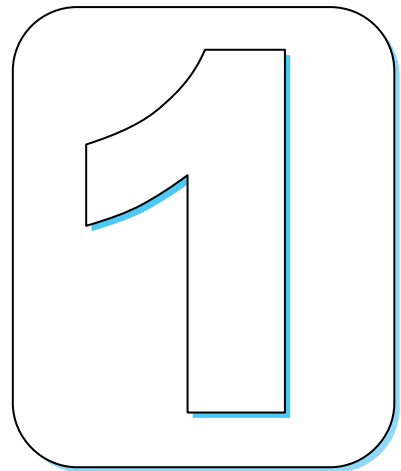

Cum ai scris cifra 1?
Colorează chipul potrivit!



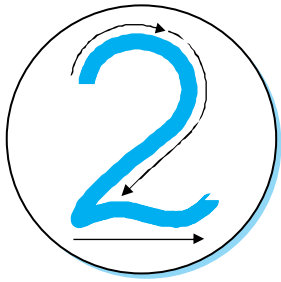

Numărul și cifra 2



● *Scrive cifra după model!*

2	2	2																	
2	2																		
2																			

2	2	2																	
2	2																		
2																			

● *Colorează doar ce seamănă cu cifra 2. Încercuiește cu roșu mulțimea păsărilor.*

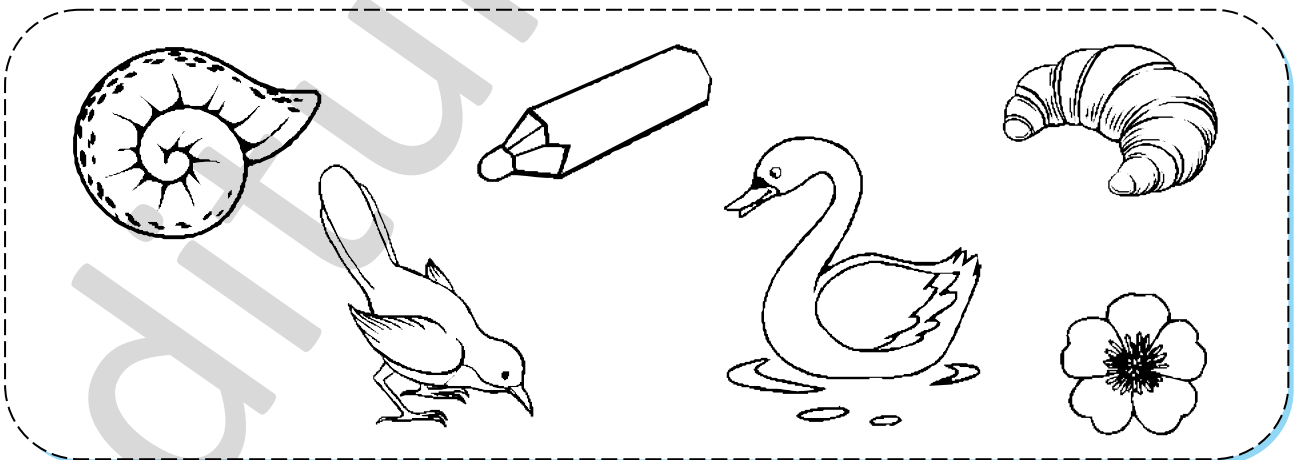

Cum ai scris cifra 2?
Colorează chipul potrivit!





Numărul și cifra 3



● *Scrive cifra după model!*

3	3	3												
3	3													
3														

3	3	3												
3	3													
3														

● *Numără și scrie câte obiecte are fiecare mulțime.*

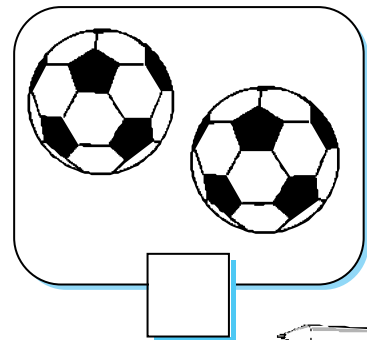
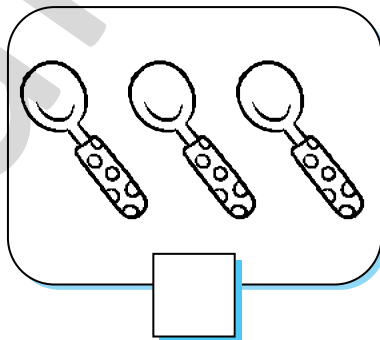
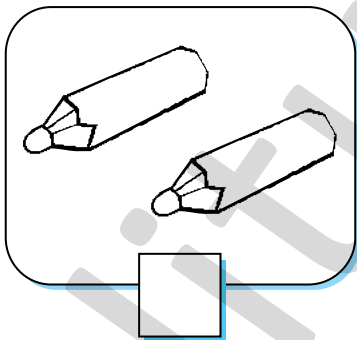

● *POȚI ȘI TU! Realizează conturul cifrei 3 cu ajutorul unor creioane colorate (vezi desenul alăturat).*

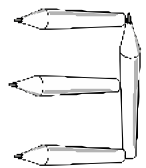

Cum ai scris cifra 3?
Colorează chipul potrivit!



Numărul și cifra 0

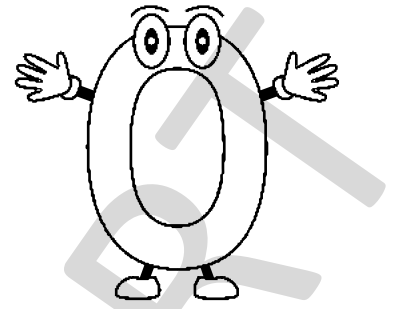
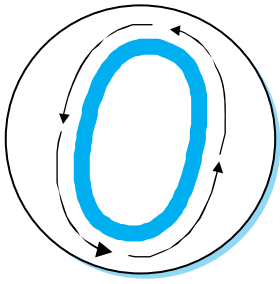

● *Scrive cifra după model!*

● *Colorează obiectul care seamănă cu cifra 0.*

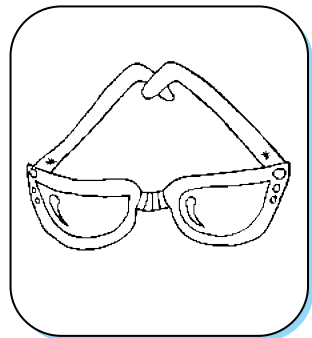
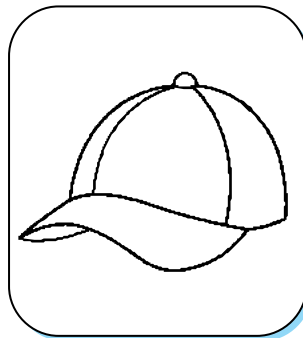
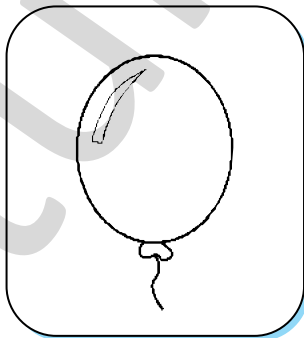
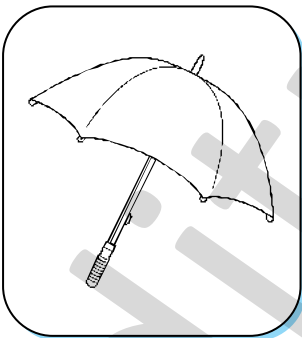

● **POTI ȘI TU!** *Desenează pe o coală separată cifra 0. Lipește sfoară sau un șnur pe contur. Realizează o ramă cu semne grafice în jurul cifrei.*

Cum ai scris cifra 0?
Colorează chipul potrivit!



CONSOLIDARE

● *Scrive crescător, apoi descrescător numerele date.*

0	1	2	3																	
0	1	2																		
0	1																			
0																				

3	2	1	0																	
3	2	1																		
3	2																			
3																				

● *Scrive în casete cifrele indicate de numărători.*

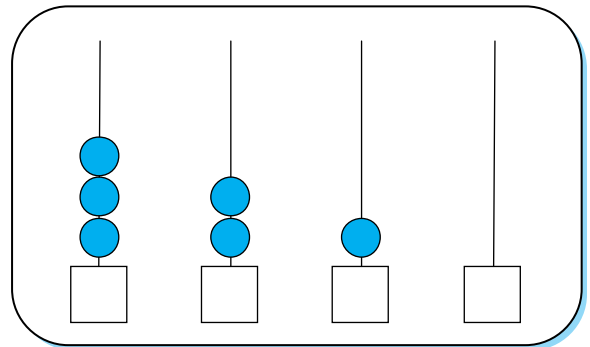
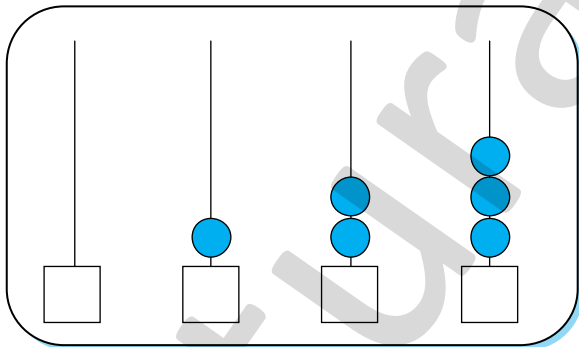

● *Desenează mulțimi cu:*

a) *două elemente*

b) *trei elemente*

c) *un element*

Cum ai lucrat?
Colorează chipul potrivit!



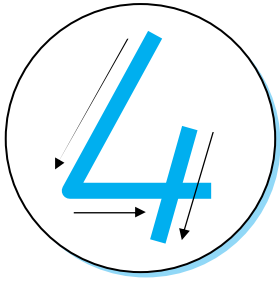

Numărul și cifra 4



● Scrie cifra după model!

4	4	4								
4	4									
4										

4	4	4								
4	4									
4										

● Numără și scrie câte obiecte are fiecare mulțime. Spune unde folosești aceste obiecte.

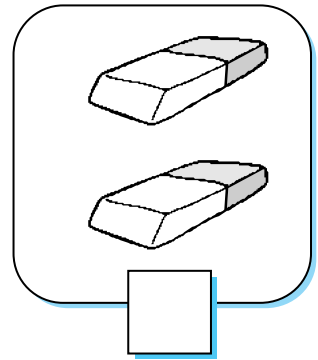
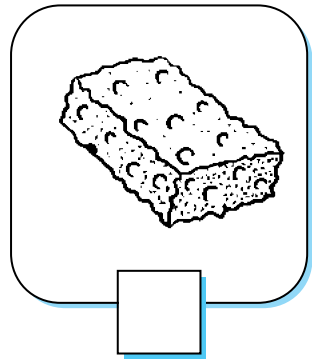
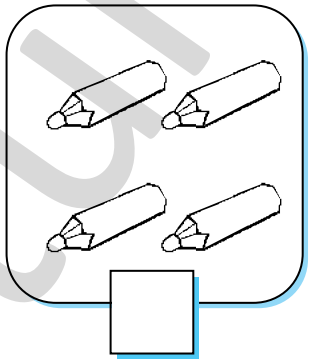
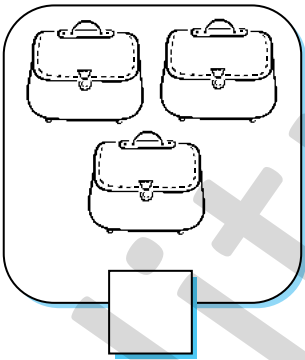

● Scrie vecinii numerelor:

1

2

3

Cum ai scris cifra 4?
Colorează chipul potrivit!





Numărul și cifra 5

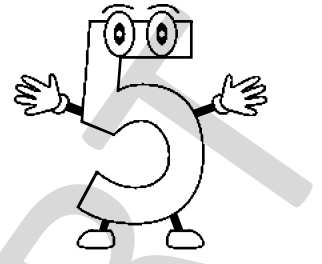
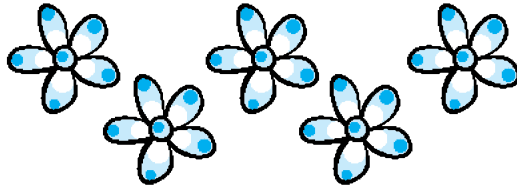

● *Scrie cifra după model!*

5	5	5								
5	5									
5										

5	5	5								
5	5									
5										

● *Recunoaște și colorează cifra 5.*

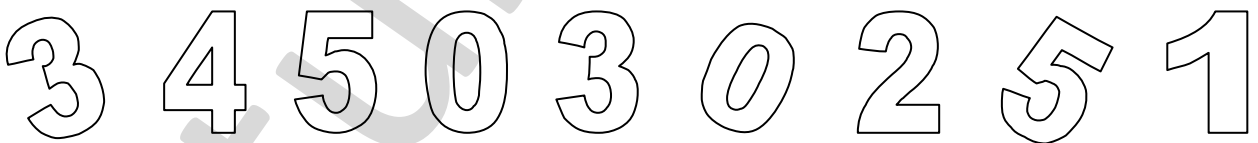

● *Fă adunările și scrie rezultatele în casete.*

$$4 + 1 = \square$$

$$3 + 2 = \square$$

● **FII CREATIV!** *Desenează conturul mâinii tale pe o foaie de hârtie. Pe fiecare degetel scrie cifrele 1, 2, 3, 4, 5. Folosește culori diferite astfel încât creația ta să fie cât mai „veselă”.*

Cum ai scris cifra 5?
Pune un coleg să te evalueze!

