

HEALTHCARE CATALOG

# DOMETIC HEALTHCARE

REFRIGERATORS AND SAFES  
FOR HEALTH AND CARE FACILITIES

 **DOMETIC** **PROFESSIONAL**





## FRIDGES

Convenient access to food items and beverages.

---

## INTRODUCTION

About Dometic

4 – 7

---

## FOOD GRADE FRIDGES

Dometic HiPro Care silent minifridges  
Ventilation instructions

10 – 11  
12 – 13



## SAFES

Dometic ProSafe – Advanced technology for safe and secure storage of valuables

---

## SAFES

About Dometic ProSafe range  
Dometic ProSafe Premium Class room safes  
Dometic ProSafe Standard Class room safes

14 – 17  
18 – 21  
22 – 25

## DOMETIC ON THE WEB

Here's where you can find the complete Dometic range, with detailed information about all products. Plus, interesting facts about our company and download links for all our catalogues.

[DOMETIC.COM/PROFESSIONAL](https://www.dometic.com/professional)





# ***THEIR HABITS THEIR WAY***

Keeping a bit of independence is about integrity and pride. It's about being able to have a glass of milk in the middle of the night if we want. To be able to decide for ourselves – it's one of life's small comforts when it means the most.

# WELL PROVEN FOR DECADES

## DOMETIC REFRIGERATORS AND SAFES FOR HEALTH AND CARE FACILITIES

Dometic is a leading manufacturer of cooling appliances for special applications – with decades of experience in the healthcare sector. Our reference list includes hospitals, retirement and nursing homes, doctor’s surgeries, pharmacies and laboratories.

Dometic Food Grade refrigerators and Dometic Medical refrigerators have been proven thousands of times over, across Europe and beyond. They are not only among the most compact of their kind available in the market, but with the new HiPro Care line, also offer a completely silent food grade cooling solution. With its ProSafe range, Dometic also provides a reliable solution for secure storage of the patients’ or residents’ valuables.

All products for the healthcare sector are manufactured to stringent quality and environmental standards in Dometic’s, certified factories. Our sales and service network spans almost 100 countries and provides personal support to customers and planners on all continents.

### RESPONSIBILITY FOR THE ENVIRONMENT

At Dometic, thinking and acting ecologically is an all-embracing process that extends to all levels – from the design of resource-saving, energy-efficient products to sustainable production processes and special recycling measures. You can be 100% sure that all applicable regulations, directives and guidelines are fulfilled.

### CERTIFIED QUALITY

- All Dometic Healthcare production plants are certified acc. ISO 9001 (quality management), ISO 14001 (environmental management) and ISO 50001 (energy management)
- All Dometic Healthcare products fulfill all requirements for product safety (UL/CSA 60335-2-24) and environmental compliance (TSCA, RoHS, etc.).



Dometic’s certified production facility at Jászberény, Hungary



# **DOMETIC PRODUCTS VALUE PROPOSAL**

**FOR HOSPITALS, RETIREMENT HOMES, PHARMACIES**

## **HOSPITALS & CLINICS**

Having their own food grade Minifridge and ProSafe in the room gives patients peace of mind and comfort while away from home. They are less dependent on staff for drinks and food and can rest assured that their valuables are safely stored. This, in turn, relieves the staff and cuts on operating costs. Hotel-like amenities can also help hospitals and clinics stand out from their competitors.

**Product examples:** HiPro Care C60SFS, MD 363

## **RETIREMENT HOMES**

Dometic food grade Minifridge take up very little space and offer a great deal of comfort. With the introduction of the new HiPro Care line, residents and patients can not only maintain their independence by keeping their favorite food items close to them but also enjoy the serenity of the noiseless environment due to its silent operation. Designed to meet the unique needs of elderly homes and hospitals, it enhances the daily experience of residents and patients while

simultaneously minimizing operational costs for healthcare facilities. Dometic medical refrigerators provide safe storage for temperature-sensitive pharmaceuticals and fast access to "daily essentials".

**Product examples:** HiPro Care A30SBI, MD 363









# GRADE



# HIPRO CARE

SMALL. SILENT. STRONG.

Dometic HiPro Care minifridges seamlessly blend into the appearance of elderly homes and hospitals. Not only are they highly efficient, with remarkably low energy usage, but they also operate silently, contributing to a peaceful environment. The strong door rack maximizes storage space, improving the functionality of its elegant design. Furthermore, they stand out for their food-grade refrigeration capabilities, designed to accommodate a range of items—from delightful cakes to fresh milk and nutritious fruits—catering to the diverse dietary needs of patients and residents alike.

## DOMETIC HIPRO CARE. THE SILENT MINI FRIDGE.

Dometic HiPro Care food-grade absorption minifridges reach an interior temperature of 4°C at up to an ambient temperature of 32°C while being completely noiseless.

### IDEAL FOR:

- Resident rooms in Elderly homes
- Patient rooms in Hospitals

Ideal for  
Patient In Room  
Comfort



Built-in



Free-standing

To learn more, visit us under [dometic.com/hiprocare](https://dometic.com/hiprocare)



**TECHNICAL DATA**

MODEL	HIPRO CARE A30S FS/BI	HIPRO CARE A40S FS/BI	HIPRO CARE C60S FS/BI
<b>Cooling technology</b>	Absorption	Absorption	Compressor
<b>Model class (litre)</b>	30	40	60
<b>Storage volume (litre)</b>	26	33	49
<b>Cabinet colour</b>	White	White	White
<b>Dimensions FS*</b> (H x W x D, in inch)	21.65 x 15.12 x 18.22	22.83 x 15.94 x 19.02	23.43 x 19.29 x 20.43
<b>Dimensions Built-in version**</b> (H x W x D, in inch)	20.47 x 15.12 x 17.56	21.65 x 15.94 x 18.35	22.24 x 19.29 x 20.08
<b>Can be built-in/integrated</b>	●	●	●
<b>Variable door hinge</b>	●	●	●
<b>LED interior light</b>	●	●	●
<b>Input rating (W)</b>	65	65	60
<b>Energy consumption</b> (kWh/24 h)	0.67 FS / 0.68 BI	0.67 FS / 0.68 BI	0.21 FS / 0.21 BI
<b>Noise level (db[A])</b>	0	0	36
<b>Features</b>	<ul style="list-style-type: none"> <li>Adjustable plastic shelf with recess for tall bottles</li> <li>Flat inner door surface for easy cleaning</li> </ul>	<ul style="list-style-type: none"> <li>2 adjustable plastic shelves with recess for tall bottles</li> <li>Flat inner door surface for easy cleaning</li> </ul>	<ul style="list-style-type: none"> <li>2 adjustable plastic shelves</li> <li>2 adjustable door racks</li> <li>Flat inner door surface for easy cleaning</li> </ul>
<b>Options</b>	<ul style="list-style-type: none"> <li>Sliding hinge</li> <li>Lock</li> </ul>	<ul style="list-style-type: none"> <li>Sliding hinge</li> <li>Lock</li> </ul>	<ul style="list-style-type: none"> <li>Sliding hinge</li> <li>Lock</li> </ul>

\*FS version: with foot frame, door decor panel and back cover, \*\* BI version: for fully-integrated installation (with sliding hinge)  
Please note our ventilation tips for built-in refrigerators (p. 12).



Food-Grade



Completely silent  
(Absorption models)



Spacious door storage



Control panel with led strip



Lockable door

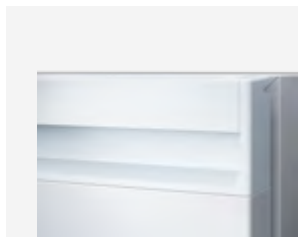

**EASY CUSTOMIZING WITH BUILT-IN MODELS**

Designed for built-in use: BI minifridges are fitted in the factory with a sliding hinge to be fastened to the furniture door to compensate for the differing turning points between the furniture and fridge door. That means the refrigerators can be easily fitted with a front panel to suit your interior design concept.

# INSTALLATION TIPS FOR BUILT-IN REFRIGERATORS

To ensure **optimum cooling performance** with minimum energy consumption, several basic principles need to be followed when installing the unit.

There must be **sufficient ventilation** here to prevent a build-up of heat. The free ventilation space for the HiPro Care for incoming air should be at least 24 in<sup>2</sup> (150 cm<sup>2</sup>) and outgoing air at least 31 in<sup>2</sup> (200 cm<sup>2</sup>).

The distance from the rear of the unit to the rear wall of the furniture must be at least 0.6 inch (15 mm). When installing the unit, ensure that it is standing on a stable and horizontal surface, and not directly near a heat source.

Ventilation must be provided as shown in the drawings below (A, B, C or D).

You can find all our documents, manuals and guidelines at [documents.dometic.com](http://documents.dometic.com).

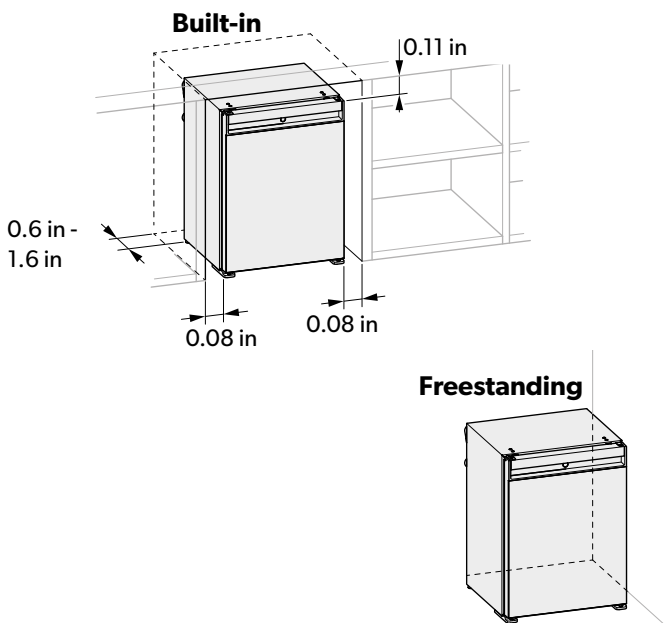
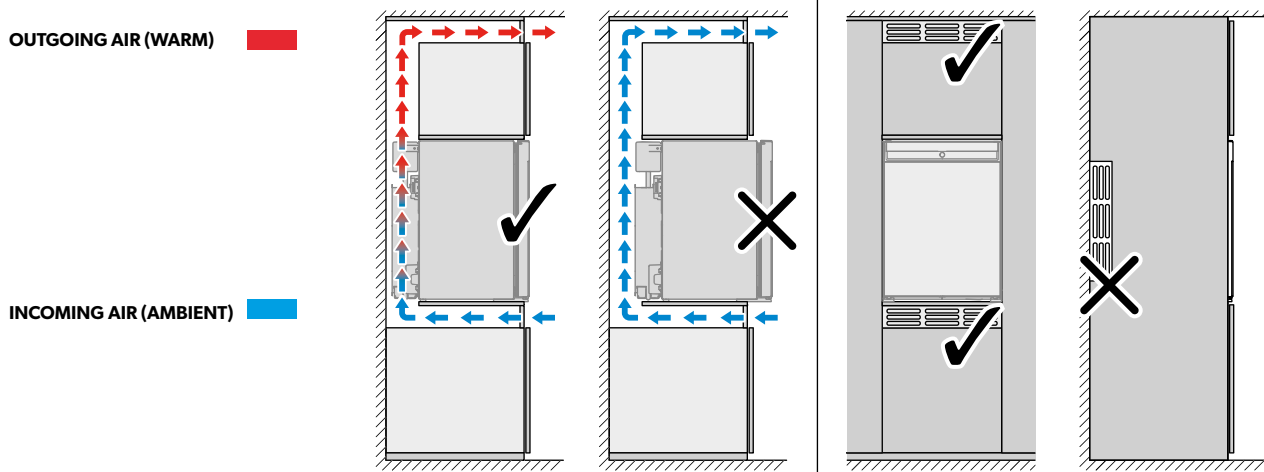

# VENTILATION GUIDELINES

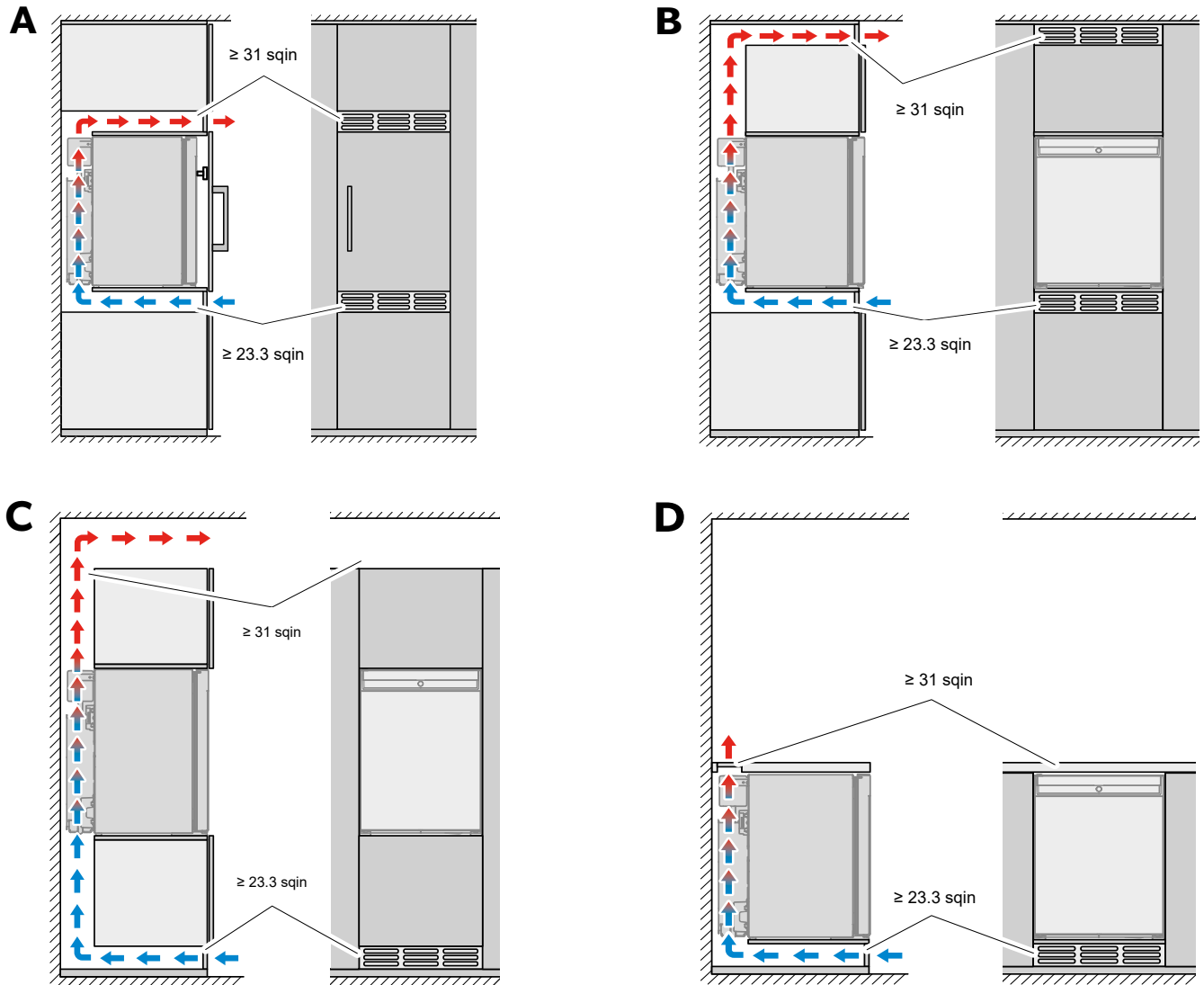

## Important note

Please read these instructions carefully and follow all instructions, guidelines, and warnings included in all our product manuals in order to ensure that you install, use, and maintain our products properly at all times.

By using our products, you hereby confirm that you have read all instructions, guidelines, and warnings carefully and that you understand and agree to abide by the terms and conditions as set forth herein. You agree to use our products only for the intended purpose and application and in accordance with the instructions, guidelines, and warnings as set forth in the product manuals as well as in accordance with all applicable laws and regulations. A failure to read and follow the instructions and warnings set forth herein may result in an injury to yourself and others, damage to your product or damage to other property in the vicinity. Our product manuals, including the instructions, guidelines, and warnings, and related documentation, may be subject to changes and updates. For up-to-date product information, please visit [dometic.com](http://dometic.com).



# **SAFETY &**



# **SECURITY**



# **FROM STANDARD TO PREMIUM**

## **The range of Dometic ProSafe models**

Security is an essential requirement for patients, and can be one of the of the main reasons for choosing or discarding a care facility. The Dometic Group aware of this, is always developing and improving all of its products in order to meet the needs of customers.

The latest product innovation Dometic has launched is a proSafe range which goes one step further in terms of design, functionality, technology and security. This proSafe range has a very modern design with a color display, an illuminated keypad, the latest anti-tampering system and a new website platform which offers the possibility to operate the safe

with the strictest security. The elegant cabinets of the new proSafe generation have rounded corners and edges for enhanced safety.

- Master key
- LED interior light
- iAudit system – unique in the industry
- Remote Emergency Opening System (REOS 2.0)  
– ultimate security and user comfort
- Battery level check





### Premium Class

Excellence in form and function: Dometic innovations like iAudit tracking and the REOS Remote Emergency Opening System ensure security on all levels.

### Standard Class

High security level combined with easy operation for perfect comfort and convenience.

## PRODUCT FINDER – THE QUICK WAY TO FIND THE RIGHT PRODUCT

### Laser-cut door

Our doors are precisely cut and crafted by a laser beam. This allows us to achieve 100% accuracy in dimensions and an extremely small clearance between the door and casing, making the door impossible to pry open.

### Anti-Tamper system

With the anti-tampering system, Dometic offers a unique security feature for their models. All anti-tampering manipulation attempts are recorded in the electronic of the safe and can be tracked back at any time.

### REOS code

REOS stands for Dometic's Remote Emergency Opening System. The emergency-opening system from Dometic is based on an innovative encoding system. The unique solution combines advanced electronics with state-of-the-art online technology to allow simple yet highly secure emergency opening by authorised facility staff.

### Premium iAudit

All operations effected on a safe must be documented – for your own security and for

your insurance provider. This is where Dometic's Premium iAudit system offers a truly convenient solution: the integrated microchip provides storage capacity for the last 1,000 events.

### SAM

The unique Dometic safe management system (SAM) allows for iAudit Trail and one time emergency code generation (REOS) from a user friendly but PIN secured internet based software tool.

● Yes / – No / ○ Optional

WHAT'S IMPORTANT TO YOU?	PREMIUM CLASS	STANDARD CLASS
Easy operation	●	●
Motorised opening	●	●
LED interior light	●	●
LED display	●	●
Emergency opening with master key	●	●
Emergency opening with master code	●	●
Emergency opening with REOS Code	○	–
Anti-Tamper System	○	–
Standard Audit	–	●
Premium iAudit	●	–
SAM	○	–
Laser-cut door	●	–
From page	34	38

A man in a tan coat is leaning over a white in-room safe in a modern kitchen. The safe is built into a white cabinet. In the background, there is a window with blue curtains and a white table with a chair. The overall scene is brightly lit, suggesting a clean and modern environment.

# ***PREMIUM CLASS IN-ROOM SAFES***

**SAFE TO SAY IT'S MORE CONVENIENT**

# DOMETIC PREMIUM CLASS SAFES

Protection for more privacy – comfortably and with absolute reliability. With a Dometic Premium Class proSafe, the room becomes a perfectly private haven for the resident. A safe place for storage, conceived and implemented according to the newest standards. Its innovative and customisable design suits every hotel in a stylish way. Smooth surfaces and rounded edges make it easy to look after and give it long-lasting character. A color display and the integrated soft-touch keypad make

operation easy. And a Premium Class proSafe also breaks new ground when it comes to protective properties: pioneering technology like the unique iAudit and the anti-tampering system ensure security on all levels. The demand for contemporary security systems with added convenience is supported by special features such as REOS 2.0 software with its emergency code-opening system (optional).

- LED interior light
- Laser-cut door and frame
- iAudit for convenient documentation
- Emergency opening with key and master code
- Remote Emergency Opening System (REOS 2.0)  
– ultimate security and user comfort (optional)



## WIDE CHOICE OF MODELS AND SIZES

Dometic ProSafe MD series Premium Class safes are available in various sizes to suit different capacity demands, interior designs and installation conditions. Sizes range from 8.2 to 29 litres.



### Batteries included

Dometic safes come ready to use.



### Automatic opening

Safe door opens automatically.

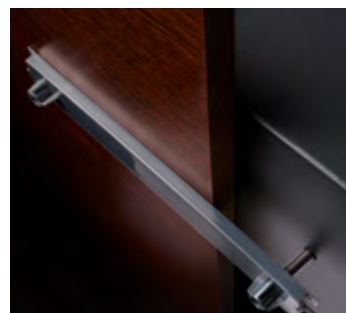

### Fixing kit

Optional fixing kit for secure fastening.



MODEL	MD 283	MD 363	MD 383
<b>TECHNICAL DATA</b>			
<b>Type of product</b>	Electronic safe		
<b>Capacity (litres)</b>	8.2	24	28
<b>Exterior dimensions</b> (H x W x D, in) (H x W x D, mm)	6.49 x 11.02 x 9.25 165 x 280 x 235	7.48 x 14.17 x 16.14 190 x 360 x 410	7.48 x 14.96 x 17.71 190 x 380 x 450
<b>Interior dimensions</b> (H x W x D, in) (H x W x D, mm)	6.37 x 10.90 x 7.28 162 x 277 x 185	7.36 x 14.05 x 14.17 187 x 357 x 360	7.36 x 14.84 x 15.74 187 x 377 x 400
<b>Steel thickness (mm)</b>	Door: 5.0 / Body 1.2	Door: 5.0 / Body 1.5	Door: 5.0 / Body 1.5
<b>Weight (lb/kg)</b>	13.4 / 6.1	22.0 / 10.2	24.9 / 11.3
<b>Keypad</b>	ADA-compliant rubber keypad		
<b>Display</b>	White LED color display, 4-digit guest code, English language		
<b>Locking mechanism</b>	Two 18 mm solid steel bolts		
<b>Locking system</b>	Motorised with automatic opening		
<b>Power</b>	4 LR6/AA 1.5 V batteries (incl.)		
<b>Cabinet color</b>	Anthracite		
<b>FEATURES</b>			
<b>LED interior light</b>	●	●	●
<b>Laser cut technology</b>	●	●	●
<b>Masterkey opening*</b>	●	●	●
<b>Mastercode opening</b>	●	●	●
<b>Anti-tampering System</b>	○	○	○
<b>REOS</b>	○	○	○
<b>iAudit</b>	●	●	●
<b>Laptop size</b>	–	15"	17"
<b>OPTIONS</b>			
	<ul style="list-style-type: none"> <li>• Left-hand hinge</li> <li>• Fixing Kit</li> <li>• Master key</li> </ul>	<ul style="list-style-type: none"> <li>• Left-hand hinge</li> <li>• Two steps emergency code opening (REOS)</li> <li>• Fixing Kit</li> <li>• Master key</li> </ul>	<ul style="list-style-type: none"> <li>• Left-hand hinge</li> <li>• Two steps emergency code opening (REOS)</li> <li>• Fixing Kit</li> <li>• Master key</li> </ul>

\*Master keys are optional, must be ordered separately, and are model-specific.



MODEL	MD 408	MD 493	MDD 403
<b>TECHNICAL DATA</b>			
<b>Type of product</b>	Electronic safe		
<b>Capacity (litres)</b>	22.5	29	15.7
<b>Exterior dimensions (H × W × D, in)</b>	7.48 × 15.94 × 13.78 190 × 405 × 350	7.48 × 19.29 × 14.56 190 × 490 × 370	7.87 × 15.75 × 15.75 200 × 400 × 400
<b>Interior dimensions (H × W × D, in)</b>	7.36 × 15.83 × 11.81 187 × 402 × 300	7.48 × 19.17 × 12.59 187 × 487 × 320	5.31 × 12.40 × 14.57 135 × 315 × 370
<b>Steel thickness (mm)</b>	Door: 5.0 / Body 1.5	Door: 5.0 / Body 1.5	Door: 5.0 / Body 1.5
<b>Weight (lb/kg)</b>	22.93 / 10.4	26.9 / 12.2	38.58 / 17.5
<b>Keypad</b>	ADA-compliant rubber keypad		
<b>Display</b>	White LED color display, 4-digit guest code, English language		
<b>Locking mechanism</b>	Two 18 mm solid steel bolts		
<b>Locking system</b>	Motorised with automatic opening		
<b>Power</b>	4 LR6/AA 1.5 V batteries (incl.)		
<b>Cabinet color</b>	Anthracite		
<b>FEATURES</b>			
<b>LED interior light</b>	●	●	●
<b>Laser cut technology</b>	●	●	●
<b>Masterkey opening*</b>	●	●	●
<b>Mastercode opening</b>	●	●	●
<b>ANTI-TAMPERING SYSTEM</b>	○	○	○
<b>REOS</b>	○	○	○
<b>iAudit</b>	●	●	●
<b>Laptop size</b>	15"	17"	15"
<b>OPTIONS</b>			
	<ul style="list-style-type: none"> <li>• Left-hand hinge</li> <li>• Two steps emergency code opening (REOS)</li> <li>• Fixing Kit</li> <li>• Master key</li> </ul>	<ul style="list-style-type: none"> <li>• Left-hand hinge</li> <li>• Fixing Kit</li> <li>• Master key</li> </ul>	<ul style="list-style-type: none"> <li>• Two steps emergency code opening (REOS)</li> <li>• Fixing Kit</li> <li>• Master key</li> </ul>

\*Master keys are optional, must be ordered separately, and are model-specific.

● Yes / – No / ○ Optional

# DOMETIC STANDARD CLASS SAFES

Robustly made with user-friendly features and functions

It puts residents' mind at rest to have a safe place for their valuables. Providing a secure space for important or valuable objects is a distinctive feature when choosing a hotel room or suite. With a Standard Class proSafe, you can create a reliable spot in the room that is worth every penny. Security and functionality are paramount with all Dometic safe models. The Standard Class safe models offer your residents a high level of security thanks to their robust construction. Their simple and intuitive usability provides perfect comfort and convenience.

- Robust and reliable
- LED display
- LED interior light
- Master key and master code emergency opening
- Wide choice: vertical, horizontal, top-opening

## DOMETIC PROSAFE MD 310 / 390 / 450 SAFE INVESTMENT

The doors on all the Standard Class safe models are precisely cut and crafted. Their robust construction and a locking system with extra-strong steel bolts leave no point of attack for burglars. The LED interior light minimises the risk of forgotten valuables. Fast and secure emergency opening is possible with a master key or master code (depending on the model).

- Robust, reliable construction for optimal safety
- LED interior light makes the contents visible at a glance
- Emergency opening with master key or master code



# DOMETIC PROSAFE MDT TOP-OPENING SAFE

Part of the Dometic Standard Class range, the Dometic proSafe MDT 400 X top-opening safe provides a simple, yet ingenious solution that is easy to operate and safe to use. The top-opening drawer safe can be integrated in an existing furniture drawer and provides easy access to guests' valuables. At the same time it meets the highest demands on ergonomic design, comfort and security with an LED inside light for standard, master key and master code opening possibility in case of emergency, digital LED illuminated keypad, four-digit code and top-opening stabilizer arm. An audio signal confirms that the safe is securely locked.

- Convenient access from above
- LED interior light makes the contents visible at a glance
- Enough room to fit laptop and tablet computers
- Ideal for installation into existing hotel room drawer
- Stabilizer arm for smooth opening and closing of the lid



## Easy operation

The operation is easy to understand and explained via the pictogram.

## Handle

Integrated handle for easy opening and closing.

## Light the way

Standard LED interior lighting.

## Soft close

Muted door closing.

**TECHNICAL DATA**



MODEL	MD 310	MD 390
-------	--------	--------

<b>Type of product</b>	Electronic safe	
<b>Capacity (litres)</b>	9	31.5
<b>Exterior dimensions</b> (H x W x D, in) (H x W x D, mm)	6.50 x 12.20 x 9.65 165 x 310 x 245	7.87 x 15.35 x 18.50 200 x 390 x 480
<b>Interior dimensions</b> (H x W x D, in) (H x W x D, mm)	6.34 x 12.05 x 7.17 161 x 306 x 182	7.71 x 15.91 x 16.45 196 x 386 x 418
<b>Steel thickness (mm)</b>	Door: 5.0 / Body 2	
<b>Weight (lb/kg)</b>	15.65 / 7.1	31.5 / 14.3
<b>Keypad</b>	Rubber keypad	
<b>Display</b>	Red LED 4-digit guest code, English language	
<b>Locking mechanism</b>	Two 19 mm steel bolts	
<b>Locking system</b>	Motorised with automatic opening	
<b>Power</b>	4 LR6/AA 1.5 V batteries (incl.)	
<b>Cabinet color</b>	Anthracite	

**FEATURES**

<b>Confirmation buzzer</b>	●	●
<b>LED interior light</b>	●	●
<b>Door handle opening</b>	-	-
<b>Masterkey opening*</b>	●	●
<b>Mastercode opening</b>	●	●
<b>Anti-tampering System</b>	-	-
<b>REOS</b>	-	-
<b>Standard Audit</b>	●	●
<b>Laptop size</b>	-	17"

**OPTIONS**

<b>(available for all models)</b>	<ul style="list-style-type: none"> <li>• Left-hand hinge</li> <li>• Fixing kit</li> <li>• Master key</li> </ul>
-----------------------------------	---

\*Master keys are optional, must be ordered separately, and are model-specific.



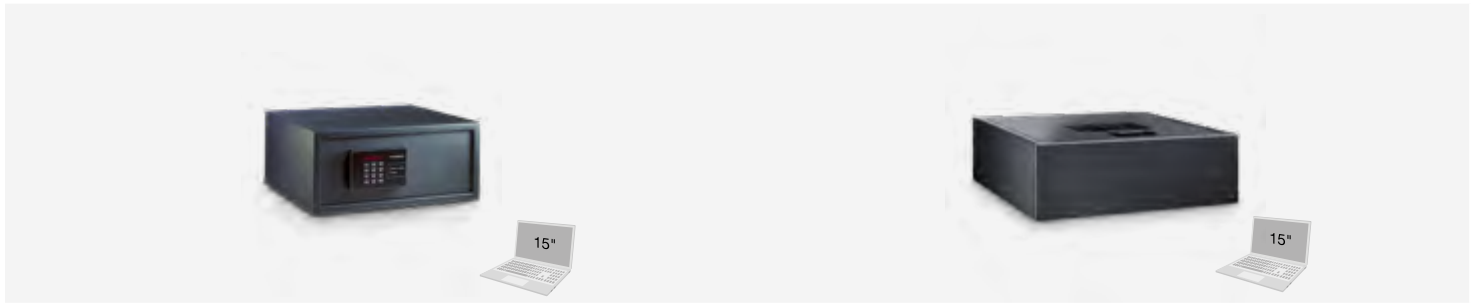

**MD 450**

**MDT 400X**

30.4	9.7
7.87 x 17.71 x 15.75 200 x 450 x 400	5.11 x 15.74 x 13.77 130 x 400 x 350
7.71 x 17.55 x 13.70 196 x 446 x 348	2.95 x 14.96 x 11.81 75 x 380 x 300
Door: 5.0 / Body 2	Door: 3.0 / Body 1.5
32.0 / 14.5	19.8/9.0
Rubber keypad	
Red LED 4-digit guest code, English language	
Two 19 mm steel bolts	
Motorised with automatic opening	
4 LR6/AA 1.5 V batteries (incl.)	
Anthracite	
●	●
●	●
-	-
●	●
●	●
-	-
-	-
●	●
15"	15"

- Left-hand hinge
- Fixing kit
- Master key

- Fixing kit
- Master key

● Yes / - No / ○ Optional



Dometic is a leading manufacturer of compact refrigeration for special applications – with decades of experience in the healthcare sector. We offer *tailormade* solutions to keep patients comfortable and safe with a wide range of cooling options to store medicines, refreshments and safe lockers to protect personal belongings. Our customers include hospitals as well as clinics, retirement and nursing homes.





---

**USA & CANADA****Dometic Corporation**

Columbia Centre 1  
5600 N. River Rd  
Suite 250  
Rosemont, IL 60018  
Tel +1 574 326 7635  
Tel +1 574 294 2511  
Mail [hospitality\\_us@dometic.com](mailto:hospitality_us@dometic.com)

**MEXICO****Dometic MX**

Circuito Médicos No. 6 Local 1  
Colonia Ciudad Satélite  
CP 53100 Naucalpan de Juárez  
Estado de México  
Tel +52 55 5374 4108  
Mail [hospitality\\_mx@dometic.com](mailto:hospitality_mx@dometic.com)

**EXPORT****Dometic Competence Center**

Circuito Médicos No. 6 Local 1  
Colonia Ciudad Satélite  
CP 53100 Naucalpan de Juárez  
Estado de México  
Tel +52 55 5374 4108  
Mail [hospitality\\_mx@dometic.com](mailto:hospitality_mx@dometic.com)

We distribute our products in around 100 markets. Please mail us at: [hospitality@dometic.com](mailto:hospitality@dometic.com), or check our website [Dometic.com/healthcare](https://Dometic.com/healthcare)