



INDEX	PAGE(S)
TekZone Hutch	216 - 217
Preconfigured Models	218 - 219
Step by Step	220 - 222
Accessories	223 - 225

TEKZONE WORKSTATION HUTCH

With the TekZone workstation hutch, you can create a personalized and organized workspace.

The work area it provides is spacious and well lit. Each TekZone Hutch is equipped with an LED light with motion sensor so the workspace lights up as soon as you open the door.

A wide range of accessories helps you to stay tidy by freeing up the work surface, while keeping your essential tools close at hand.

The ingenious door mechanism allows you to open and close the hutch easily, smoothly and securely. With the full-width handle, you can open the door with any hand position. The door is fitted with a lock to protect the contents of the hutch.

The TekZone Hutch installs on heavy-duty cabinets, Rousseau WS workstations and most other workstations on the market. Treat yourself to a unique solution!

CUSTOMIZE YOUR TEKZONE WORKSTATION HUTCH WITH THE MYMODEL-R ONLINE CONFIGURATOR



THE ROUSSEAU DIFFERENCE



Creates a secure, organized and personalized workspace.



Easy and tool-free reconfiguration allows your workstation to evolve in line with your needs.

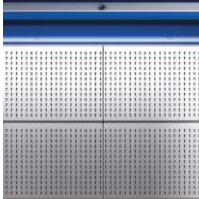

Spacious and well-lit workspace.



Door opens and closes easily, smoothly and securely.



Types of lock:
L3 - Key Lock
L50 - Digital Lock
L100 - Smart Lock

GENERAL DIMENSIONS



PRECONFIGURED MODELS



TEKZONE MOBILE WORKCENTER

PRODUCT NO.	W × D × H
TZ-C002X*	60" × 27" × 77½"
1 Multi-drawer mobile cabinet	R5GKG-3018
1 Thin stainless steel top	RH11-6027
1 Hutch with painted steel utility panels, LED light with motion sensor, 1 painted steel power feed panel with 3 power outlets (15A) and 2 USB ports (1 A, 1 C)	TZ-JKG40U2002P
1 Battery charger shelf	RH54-26
1 Electronic tablet arm	EA64-62-01
2 Half width shelves	RH60-2412
2 Partial dividers	SH52-1206
1 Plastic bin rail	WM9C-12

60"W HUTCH

PRODUCT NO.	W × D × H
TZ-JKG40U2104P	60" × 27" × 40"
1 Hutch with painted steel utility panels, LED light with motion sensor, 1 painted steel power feed panel with 3 power outlets (15A) and 2 USB ports (1 A, 1 C)	TZ-JKG40U2002P
1 Battery charger shelf	RH54-26
1 Electronic tablet arm	EA64-62-01
2 Half width shelves	RH60-2412
2 Partial dividers	SH52-1206
1 Plastic bin rail	WM9C-12

NOTE: *The hutch is factory assembled on the cabinet with this model.



TEKZONE WORKCENTER

PRODUCT NO.	W × D × H
TZ-C040S*	48" × 30" × 76"
1 Multi-drawer cabinet with 4"H base	R5KKG-3030S
1 Pre-punched stainless steel top	RC35-4830-02
1 Hutch with stainless steel utility panels, LED light with motion sensor, 1 stainless steel power feed panel with 3 power outlets (15A), 2 USB ports (1 A, 1 C), knockout and perforation	TZ-JHG40U3002S
1 Electronic tablet arm	EA64-62-01
2 Half width shelves	RH60-2412
3 Partial dividers	SH52-1206
1 Can holder	WM9D-12
1 Wire spool and roll holders	WM9P-1201

48"W HUTCH

PRODUCT NO.	W × D × H
TZ-JHG40U3104S	48" × 27" × 40"
1 Hutch with stainless steel utility panels, LED light with motion sensor, 1 stainless steel power feed panel with 3 power outlets (15A), 2 USB ports (1 A, 1 C), knockout and perforation	TZ-JHG40U3002S
1 Electronic tablet arm	EA64-62-01
2 Half width shelves	RH60-2412
3 Partial dividers	SH52-1206
1 Can holder	WM9D-12
1 Wire spool and roll holder	WM9P-1201

NOTE: *The hutch is factory assembled on the cabinet with this model.



TEKZONE CONSULTATION STATION

PRODUCT NO.	W×D×H
TZ-C010P*	36"×27"×80"
1 Heavy-duty cabinet with 4" base	R5AEE-3414P
1 Pre-punched painted steel top	RC37-3627-02
1 Hutch with painted steel utility panels, LED light with motion sensor, 1 painted steel power feed panel with 3 power outlets (15A) and 2 USB ports (1 A, 1 C)	TZ-JEE40X2002P
1 Monitor mount	RH52-15
1 Keyboard tray	RH53-25
1 Can holder	WM9D-09

36"W HUTCH

PRODUCT NO.	W×D×H
TZ-JEE40X2102P	36"×24"×40"
1 Hutch with painted steel utility panels, LED light with motion sensor, 1 painted steel power feed panel with 3 power outlets (15A) and 2 USB ports (1 A, 1 C)	TZ-JEE40X2002P
1 Monitor mount	RH52-15
1 Keyboard tray	RH53-25
1 Can holder	WM9D-09

NOTE: *The hutch is factory assembled on the cabinet with this model.



TEKZONE WORKSTATION

PRODUCT NO.	W×D×H
TZ-C018PW	60"×30"×74"
1 Desk with closed legs and pre-punched wood top, 1 power outlet (15A) and 2 USB ports (1 A, 1 C)	WSA2090
1 Hutch with painted steel utility panels, LED light with motion sensor, 1 L50 lock	TZ-UKH40U002PL50
1 Painted steel power feed panel with 3 power outlets (15A) and 2 USB ports (1 A, 1 C)	TZ-M060T2P
1 Battery charger shelf	RH54-26
1 Half width shelf	RH60-3008
1 Wire spool and roll holders	WM9P-2601
1 Laptop arm	EA64-42
1 Can holder	WM9D-09
1 Plastic bin rail	WM9C-09
1 Tool rail	RH47-6001
1 Balancer trolley	WM48-01
1 Tool balancer	WM49-01

60"W HUTCH

PRODUCT NO.	W×D×H
TZ-JKH40U2102P	60"×27"×40"
1 Hutch with painted steel utility panels, LED light with motion sensor, 1 L50 lock	TZ-UKH40U002PL50
1 Painted steel power feed panel with 3 power outlets (15A) and 2 USB ports (1 A, 1 C)	TZ-M060T2P
1 Battery charger shelf	RH54-26
1 Half width shelf	RH60-3008
1 Wire spool and roll holders	WM9P-2601
1 Laptop arm	EA64-42
1 Can holder	WM9D-09
1 Plastic bin rail	WM9C-09
1 Tool rail	RH47-6001
1 Balancer trolley	WM48-01
1 Tool balancer	WM49-01

STEP BY STEP

4 EASY STEPS

You can quickly and easily configure your own layout in just four steps.

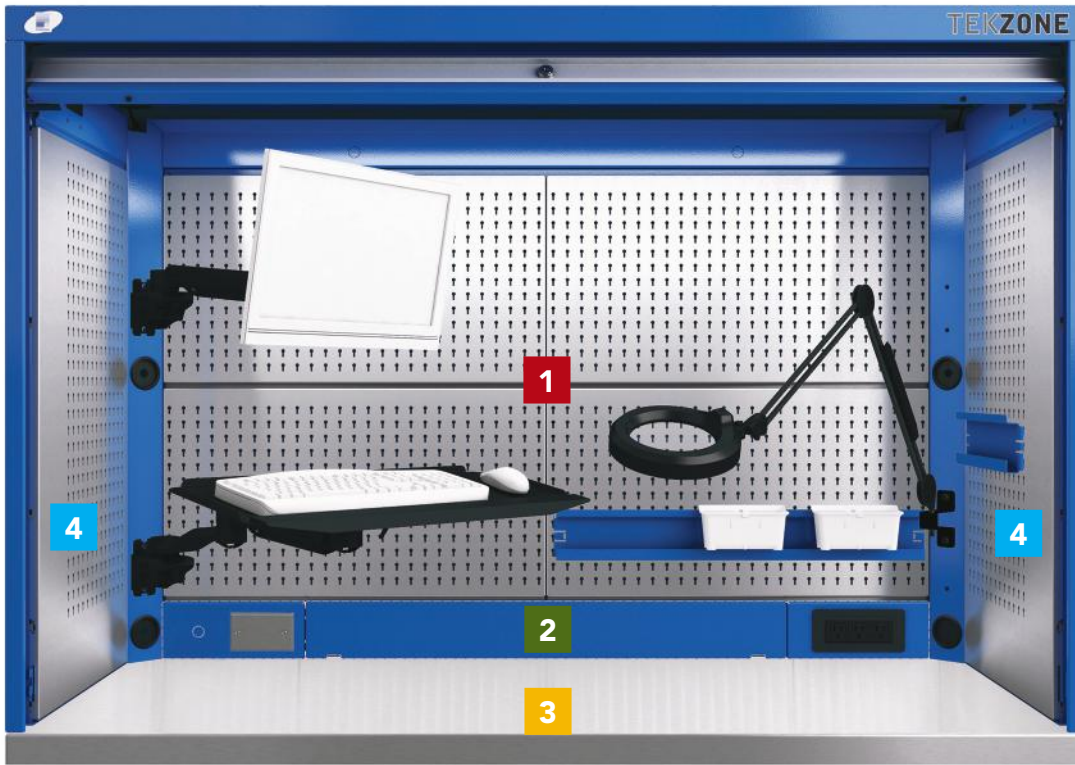

STEP 1: CHOOSE PANELS

Choose the panels you want in the hutch: panels for plastic bins, utility panels or finishing panels. To ensure your TekZone hutch remains bright, you can choose between stainless steel or painted steel panels. For painted steel panels, we recommend choosing one of the following five paint colors:

White 616	Frost White 061	Light Gray 071	Beige 041	Modern Gray 745

STEP 2: CHOOSE POWER FEED PANEL

Then you choose a power feed panel from the following five models:

PRODUCT NO.	DESCRIPTION
TZ-M0_ _ 00 _	Cover panel, no outlets
TZ-M0_ _ T1 _	3 power outlets (15A), knockout and perforation
TZ-M0_ _ T2 _	3 power outlets (15A), 2 USB ports (1 A, 1 C)
TZ-M0_ _ T3 _	3 power outlets (15A), 2 USB ports (1 A, 1 C), knockout and perforation
TZ-M0_ _ T4 _	3 power outlets (15A)

STEP 3: CHOOSE TOP

In this step you choose which type of work surface best meets your needs:

TOPS FOR R CABINETS					
HEIGHT	PAINTED STEEL	STAINLESS STEEL	LAMINATED HARDWOOD	NITRILE 3/4"	NEOPRENE 1/4"
1 1/4"	RC37	RC35	WS14	-	-
Thin	RH10	RH11	-	-	-
Mat	-	-	-	RH91	RH90

TOPS FOR R WORKSTATIONS					
HEIGHT	PAINTED STEEL	STAINLESS STEEL	LAMINATED HARDWOOD	NITRILE 3/4"	NEOPRENE 1/4"
1 1/4"	RC37	RC35	WS14	-	-
Mat	-	-	-	RH91	RH90

TOPS FOR WS WORKSTATIONS					
HEIGHT	PAINTED STEEL	STAINLESS STEEL	LAMINATED HARDWOOD	NITRILE 3/4"	NEOPRENE 1/4"
1 1/4"	WS10	WS12	WS14	-	-
Mat	-	-	-	RH91	RH90

NOTE: The TekZone Hutch must be installed on a work surface.

STEP 4: ACCESSORIES

You can equip the hutch with accessories of your choice.



1 DIMENSIONS AND PANEL TYPES

UTILITY PANELS

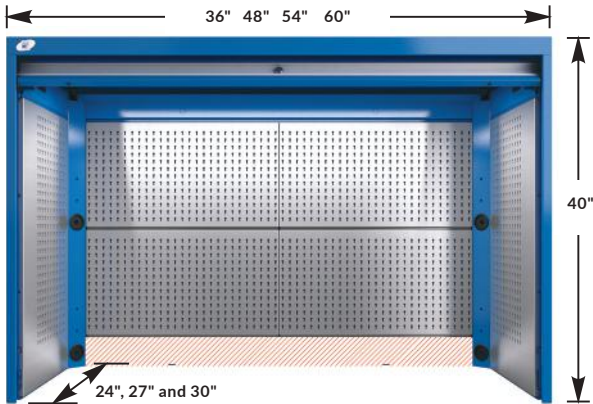

UTILITY AND PLASTIC BINS PANELS

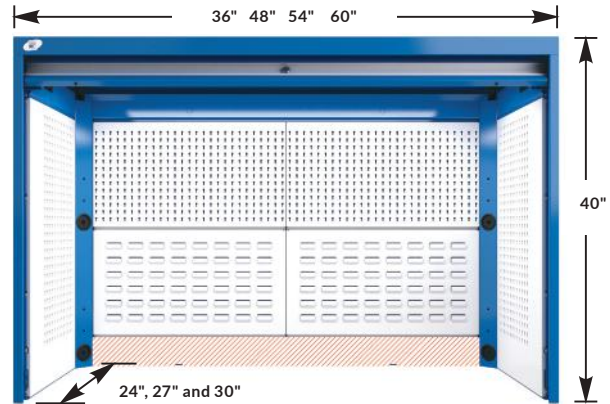

SPECIFY THE WIDTH AND DEPTH REQUIRED AND THE PANEL FINISH

Width: 36" = E, 48" = H, 54" = J, 60" = K

Lock: L3, L50, SL=L100

Depth: 24" = E, 27" = G, 30" = H

Panel Finish: Painted steel = P, Stainless steel = S

Code: TZ-U 40U002

SPECIFY THE WIDTH AND DEPTH REQUIRED

Width: 36" = E, 48" = H, 54" = J, 60" = K

Lock: L3, L50, SL=L100

Depth: 24" = E, 27" = G, 30" = H

Panel Finish: Painted steel = P

Code: TZ-U 40X002P

UTILITY AND FINISHING PANELS

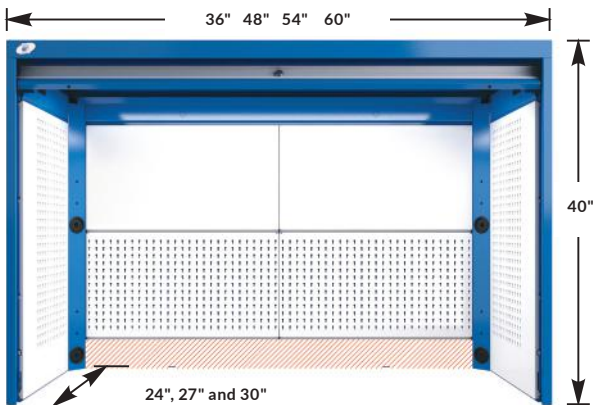

BACK PANELS LOGIC

36" wide: Two full-width 15" high panels

48", 54" and 60" wide: Four half-width 15" high panels

BACK AND SIDE PANELS CAPACITY

Panel capacity: 100lb per panel

SPECIFY THE WIDTH AND DEPTH REQUIRED AND THE PANEL FINISH

Width: 36" = E, 48" = H, 54" = J, 60" = K

Lock: L3, L50, SL=L100

Depth: 24" = E, 27" = G, 30" = H

Panel Finish: Painted steel = P, Stainless steel = S

Code: TZ-U 40X004

STEP BY STEP

2 POWER FEED PANEL

- The power feed panels include a 10' power cord
- The center panel can be used to manage power and network cables
- Electric voltage: 110 volts

SPECIFY THE WIDTH AND FINISH REQUIRED

Width: 36" = <u>36</u> 48" = <u>48</u>	54" = <u>54</u> 60" = <u>60</u>	TZ-M0__T4__	Painted steel = <u>P</u> Stainless steel = <u>S</u>
--	------------------------------------	-------------	--

FINISHING PANEL NO OUTLETS



3 POWER OUTLETS (15A), KNOCKOUT AND PERFORATION



3 POWER OUTLETS (15A) AND 2 USB PORTS (1 A, 1 C)



3 POWER OUTLETS (15A), 2 USB PORTS (1 A, 1 C), KNOCKOUT AND PERFORATION



3 POWER OUTLETS (15A)



3 CHOICE OF TOP

SPECIFY THE WIDTH AND DEPTH REQUIRED

Width: 36" = <u>36</u> 48" = <u>48</u>	54" = <u>54</u> 60" = <u>60</u>	RH90-__ __	Depth: 24" = <u>24</u> 27" = <u>27</u>	30" = <u>30</u>
--	------------------------------------	------------	--	-----------------

THIN PAINTED STEEL TOP



THIN STAINLESS STEEL TOP



1 3/4" PAINTED STEEL TOP*

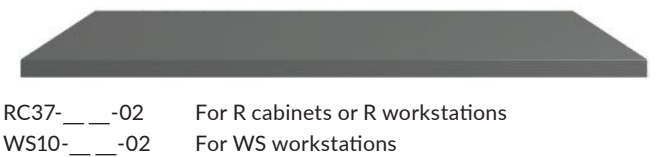

1 3/4" STAINLESS STEEL TOP*

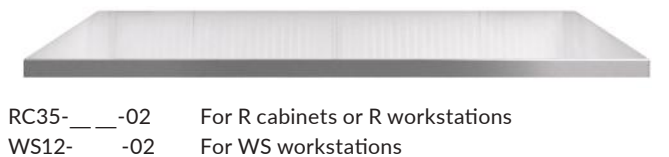

1 3/4" LAMINATED HARDWOOD TOP*



PROTECTIVE MAT**

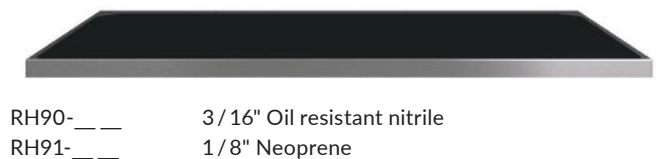

NOTES: * These tops are pre-punched for easy installation of the TekZone Hutch.
 **Top to be ordered separately.
 The TekZone Hutch must be installed on a work surface.

4 ACCESSORIES

SLOPED TOP

RH89



- Keeps the workspace clean and safe while reducing clutter
- 8"H

PRODUCT NO.	W×D
RH89-362408	36" × 24"
RH89-362708	36" × 27"
RH89-363008	36" × 30"
RH89-482408	48" × 24"
RH89-482708	48" × 27"
RH89-483008	48" × 30"
RH89-542408	54" × 24"
RH89-542708	54" × 27"
RH89-543008	54" × 30"
RH89-602408	60" × 24"
RH89-602708	60" × 27"
RH89-603008	60" × 30"

PLASTIC BIN RAIL

WM9C



- Plastic bins hook onto the rail for efficient storage of small parts
- Compatible with RG20 plastic bins (sold separately), see page 297

PRODUCT NO.	WIDTH	USE
WM9C-09	9"	for 24"D side panels
WM9C-12	12"	for 27"D side panels
WM9C-15	15"	for 30"D side panels
WM9C-20	20"	for half-width back panels on a 48"W hutch
WM9C-23	23"	for half-width back panels on a 54"W hutch
WM9C-26	26"	for half-width back panels on a 60"W hutch for full-width back panels on a 36"W hutch

WIRE SPOOL AND ROLL HOLDERS

WM9P



- Ideal for wire spools or paper towel rolls
- Tube diameter: 3/4"
- Load capacity: 50lb.

PRODUCT NO.	WIDTH	USE
WM9P-0901	9"	for 24"D side panels
WM9P-1201	12"	for 27"D side panels
WM9P-1501	15"	for 30"D side panels
WM9P-2001	20"	for half-width back panels on a 48"W hutch
WM9P-2301	23"	for half-width back panels on a 54"W hutch
WM9P-2601	26"	for half-width back panels on a 60"W hutch for full-width back panels on a 36"W hutch

CAN HOLDER

WM9D



- Ideal for storing cans and other containers of different sizes
- Compatible with side and back panels
- 3"D and 4"H

PRODUCT NO.	WIDTH	COMPATIBILITY
WM9D-09	9"	24" D
WM9D-12	12"	27" D
WM9D-15	15"	30" D

MONITOR MOUNT

RH52



- Supports a monitor compliant with the VESA 75 and 100 standards
- Includes a central cutout for cable management from the rear of the mount
- Two positions: vertical or angled 10° forward to reduce reflections
- Compatible with utility panels and finishing panels only

PRODUCT NO.
RH52-15

BATTERY CHARGER SHELF

RH54



- Hooks onto back utility panels at the desired height
- 25" usable width accommodates several chargers at once
- Includes a non-slip protective mat
- Includes a built-in power bar with six power outlets (15A / 120V, with switch, circuit breaker and 15' power cord)
- Includes storage space for cable management

PRODUCT NO.	WIDTH
RH54-26	26"

KEYBOARD TRAY

RH53



- Unique and heavy-duty design with palm rests
- 25"W to accommodate a keyboard and mouse
- Includes a non-slip protective mat

PRODUCT NO.
RH53-25

SHELF AND DIVIDER RH60 / RH61

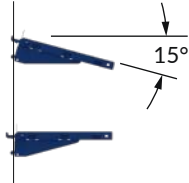

- Hooks onto back utility panels at the desired height
- Can be installed at a right angle or angled 15°
- The shelf is reversible and its edge can act as a back stop for plastic bins and ring binders
- Capacity: 100lb. (evenly distributed)
- Compatible with SH52-1206 dividers in 2" increments c / c
- Width compatibility:
 - 36"W hutches: full-width shelf
 - 48"W, 54"W and 60"W hutches: half-width shelf
- Add 08 to the product number for an 8"D shelf and 12 for a 12"D shelf.

PRODUCT NO.	WIDTH	COMPATIBILITY
RH60-24__	20"	Half-width shelf for 48"W hutch
RH60-27__	23"	Half-width shelf for 54"W hutch
RH60-30__	26"	Half-width shelf for 60"W hutch
RH61-36__	29"	Full-width shelf for 36"W hutch
SH52-1206		Divider

INTERMEDIATE SHELF AND BOTTOM SHELF RH64 / RH65

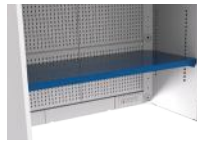

- Full-length and full-depth shelf
- Capacity: 200 lb (evenly distributed weight)
- Compatible with SH52-2106 dividers in 3" increments c / c
- RH64 Intermediate Shelf:
 - Attaches to RH35 side panels only
 - Compatible with RH20 and RH21 back utility panels; the area next to the shelf will be unusable
 - To add to a preconfigured TZ model, replace side panels with RH35 side panels
 - Not compatible with RH22 and RH23 back panels for plastic bins
 - Not compatible with the following side panels: RH32 panels for plastic bins, RH30 and RH31 utility panels and RH28 and RH29 finishing panels
- RH65 Bottom Shelf:
 - A top (see page 222) is required for joining the hutch to the cabinet underneath

PRODUCT NO.	WIDTH
RH__-3627	36"
RH__-4827	48"
RH__-5457	54"
RH__-6027	60"

NOTE: RH36 to RH41 power feed and cable management panels cannot be used with the bottom shelf.

DIGITAL LOCK L50



354

- Electronically locks slide-up door
- No key required
- Up to 20 different users can be programmed
- 4- to 8-digit access codes
- Simplifies access management to drawers
- To order: Add L50 to the door number, e.g., RH06-WW40L50
- For replacement parts or to retrofit, see page 354

PRODUCT NO.
RH06-WW40L50

L50

SMART LOCK L100



355

- Handy unlocking via a transponder or smartphone
- User-friendly and intuitive
- No key required
- Easy and comprehensive management
- To order: Add L100 to the door number, e.g., RH06-WW40L100
- For replacement parts or to retrofit, see page 356

PRODUCT NO.
RH06-WW40L100

L100

NOTE: NFC transponders are not included with the lock, they must be ordered separately (pack of 5). See page 356.

TOOL RAIL

RH47



- Holds one or more WM48 balancer trolleys
- Color: black
- Capacity: 25lb.
- For 48"W, 54"W and 60"W hutches

PRODUCT NO.	WIDTH
RH47-4801	48"
RH47-5401	54"
RH47-6001	60"

TOOL BALANCER

WM49



- For hanging tools over the work surface
- 6' metal cable with tension adjustment
- Color: black
- Capacity: 3lb. max.

PRODUCT NO.
WM49-01

LAMP WITH MAGNIFIER AND LED LIGHT

RH50



- Diopter: 5 (2.25x magnification)

PRODUCT NO.	USE
RH50-02	Support and Lamp with magnifier and LED light

BALANCER TROLLEY

WM48



- Inserts into a RH47 tool rail
- Color: black
- Holds a pneumatic connection

PRODUCT NO.
WM48-01

COMPUTER ARTICULATED ARMS

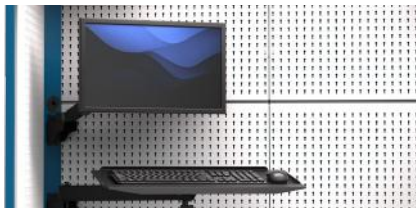

- To view all available types of articulating arms, [see pages 310-311.](#)