

The logo for 'ambic' is located in the top right corner. It features the word 'ambic' in a bold, white, sans-serif font. Above the letters 'a' and 'i', there are stylized yellow and orange geometric shapes that resemble lightning bolts or abstract brushstrokes.

# WASHROOMS CATALOGUE



**BRITISH MADE**  
**BUILT TO LAST**

## Contact Us

Ambic Manufacturing

Ambic House

Stella Gill Industrial Estate

Pelton Fell, Chester-le-Street

County Durham

DH2 2RN

Tel: 0191 389 1888

Email: [sales@ambicmanufacturing.com](mailto:sales@ambicmanufacturing.com)

Visit us at:

[www.ambicmanufacturing.com](http://www.ambicmanufacturing.com)

Social Media:

[www.linkedin.com/company/ambicmanufacturing/](http://www.linkedin.com/company/ambicmanufacturing/)

[www.instagram.com/ambicmanufacturing/](http://www.instagram.com/ambicmanufacturing/)

[www.facebook.com/ambicman/](http://www.facebook.com/ambicman/)

# Contents

## Introduction 1

|                  |   |
|------------------|---|
| Who we are       | 1 |
| Our Capabilities | 2 |
| Our Process      | 3 |

## Cubicles 4

|                 |   |
|-----------------|---|
| Ambic Washrooms | 4 |
| Overview        | 4 |
| Cubicles        | 4 |
| Typical Layouts | 5 |

## Vanities 7

|                 |   |
|-----------------|---|
| Vanities        | 7 |
| Typical Layouts | 7 |

## IPS / Ducting 9

|                 |   |
|-----------------|---|
| IPS / Ducting   | 9 |
| Typical Layouts | 9 |

## Full Turnkey Solution 11

|                       |    |
|-----------------------|----|
| Full Turnkey Solution | 11 |
| Gallery               | 13 |

## Who we are

Ambic Manufacturing are based at our own purpose built, state of the art factory in County Durham (Chester-le-Street). We have over 30 years of trading experience in the design, manufacture and installation of bespoke furniture in many fields.

Ambic's ethos is quite simple; we are genuine people making quality furniture. We are known for making furniture that is engineered to last and we most certainly do not back down from a challenge.

We work extensively with individuals, designers, contractors, architects and other businesses to design, manufacture and install bespoke furniture. We are also FF&E procurement specialists so if we can't make it in house, then we will have a partner who can.



## Our Capabilities

- 1 MIG WELDING - MILD STEEL**  
We can also MIG & TIG other metals such as aluminium, stainless steel etc.
- 2 TWO OF OUR FIVE WOODWORKING CNCs**  
These machines are capable of cutting and profiling most non-metallic substrates.
- 3 POWDERCOATING BOOTH**  
Anything metallic we tend to powdercoat for durability. We can also chemical strip and media blast to refurb older items needing a refresh.
- 4 CNC TUBE BENDER**  
Tube up to 2" diameter can be bent into almost any shape. Other sizes can be formed depending on availability of tooling for the machine.
- 5 FIRE DOOR CNC MACHINE**  
We are also able to pre-machine hinges, handles, intumescent strip, lock assemblies and even add grooved patterns to the face of the door.
- 6 IN-HOUSE DELIVERY**  
We have our own fleet of vehicles ready to deliver our manufactured items to you. Probably a good time to mention that we can install too.
- 7 PALLET OF LAMINATED PANELS**  
Pressed in-house with our heated press ready to be machined into cabinetry components.
- 8 LARGE WORKTOP CNC MACHINE**  
This machine has a large bed allowing us to machine large / long items with minimal joins. It also specialises in plinths and pelmets.
- 9 METAL SAW**  
The first requirement before manufacturing is to cut the tube to size.



## Our Process

One of our sales staff/project managers will visit to discuss your needs and choose a suitable option to price, they will then estimate based on your needs and measurements.

When an order is placed your lab will be surveyed by a member of our installation team who along with the project manager will liaise with our design department to create manufacturing drawings for your approval. When these are reviewed and approved we will then put your furniture into manufacture.

Depending on what solution you have chosen we will take stock items or manufacture from raw material to create all the components for your lab.

Our installation team will be in touch during the process to book an installation date which works for you.

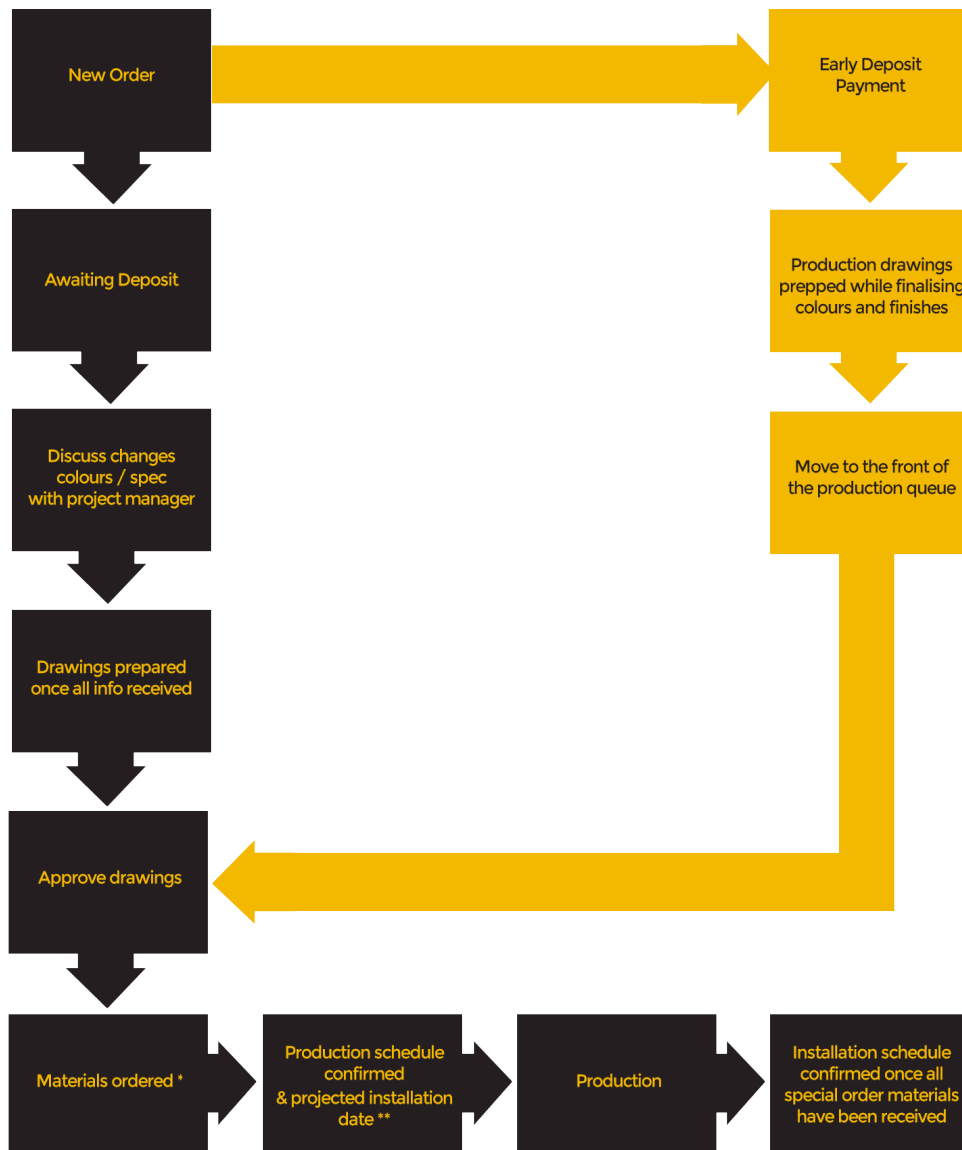

## Ambic Washrooms

### Overview

At Ambic we can provide a bespoke fitted washroom solution to fit your space.

Each Washroom is manufactured in house to your exact specification.

Our standard range is constructed from 12-13mm Solid Grade Laminate which is water resistant, hardy and will last unlike MFC/chipboard which is often used.



### Cubicles

Constructed with 12-13mm SGL Panelling,

Can be arranged in various ways with single or multiple cubicles with inward or outward opening doors.

Our Satin anodised aluminium hardware gives a long lasting product with a quality appearance & feel.



## Typical Layouts

Between two walls

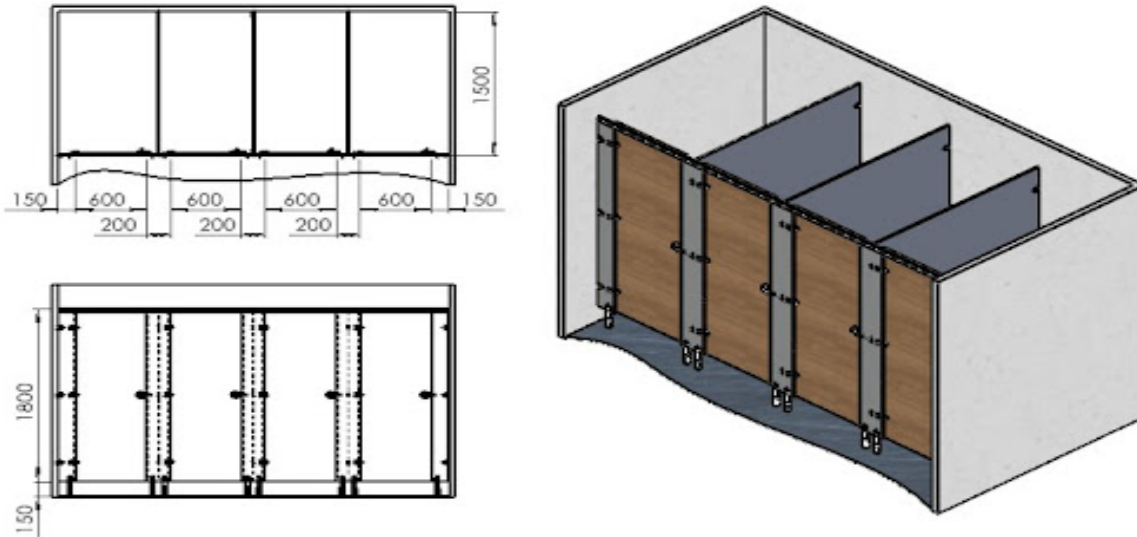

From a corner using an additional partition as an end panel (can be LH or RH)

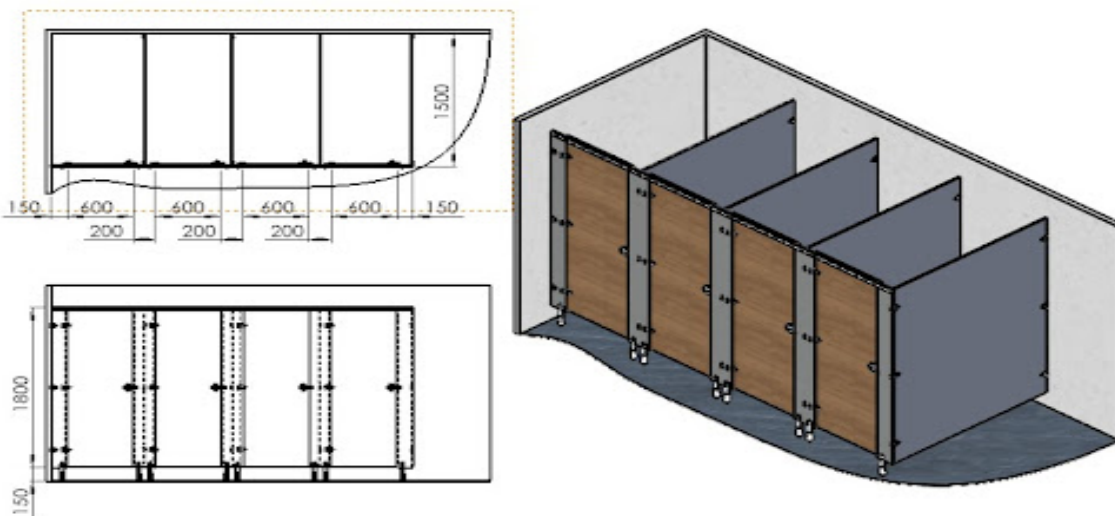

We also provide an option for childrens cubicles which have shaped division panels & shorter doors (to aid adult supervision), Also an option to have magnetic door catches rather than indicator bolts for young children:

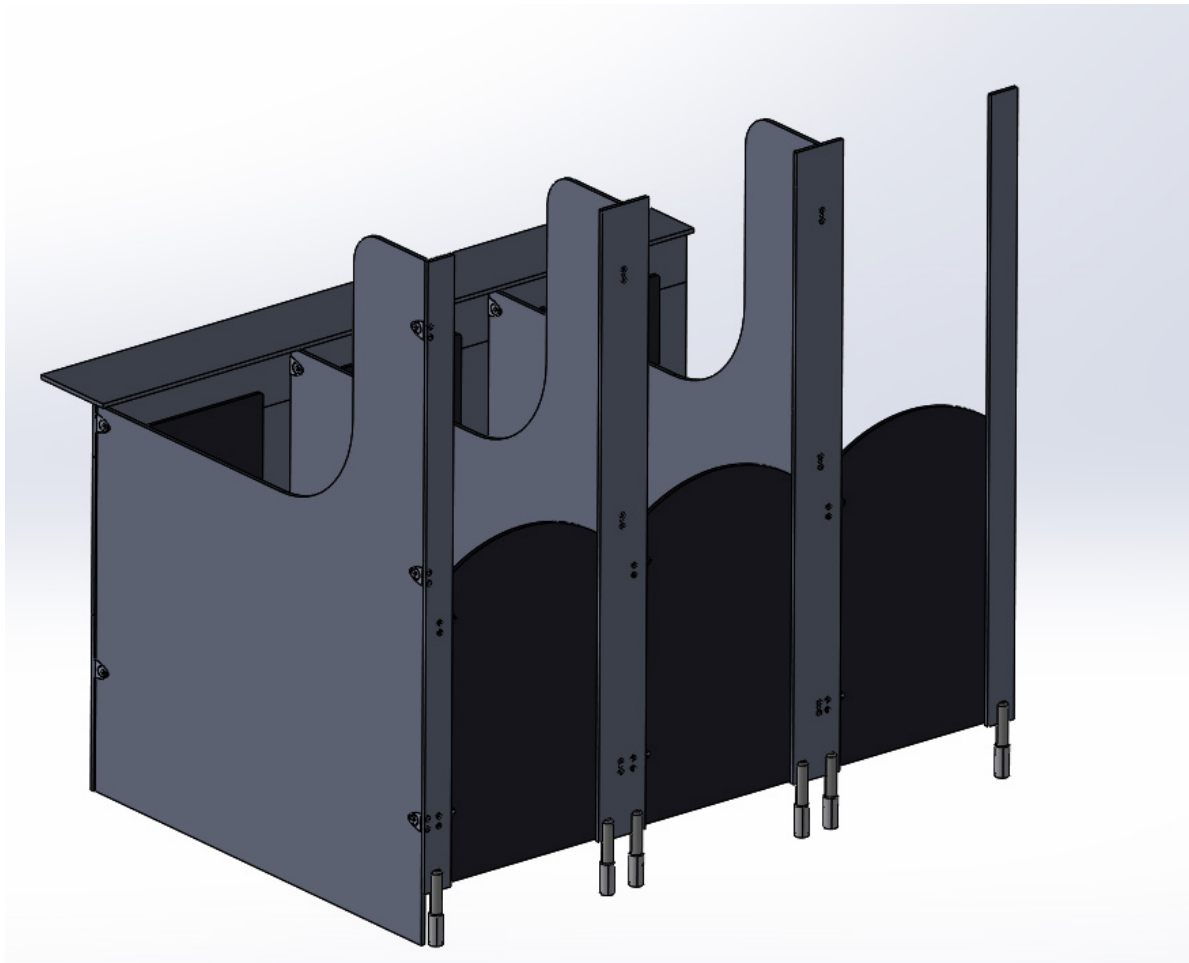

## Vanities

Our Vanity Units are also SGL Construction with SGL Splashback/upstand.

They include lift off panels under each sink using tried and testing fitting, these give easy access to plumbing for fitting/service/repair work.

These Vanity unit are very hardy and will not swell and rot away being a water resistant material.

Each vanity are machined to take a selection of our standard sink bowl options making fitting quick and easy (Sola Optima 450 shown in drawings)



## Typical Layouts

Between two walls

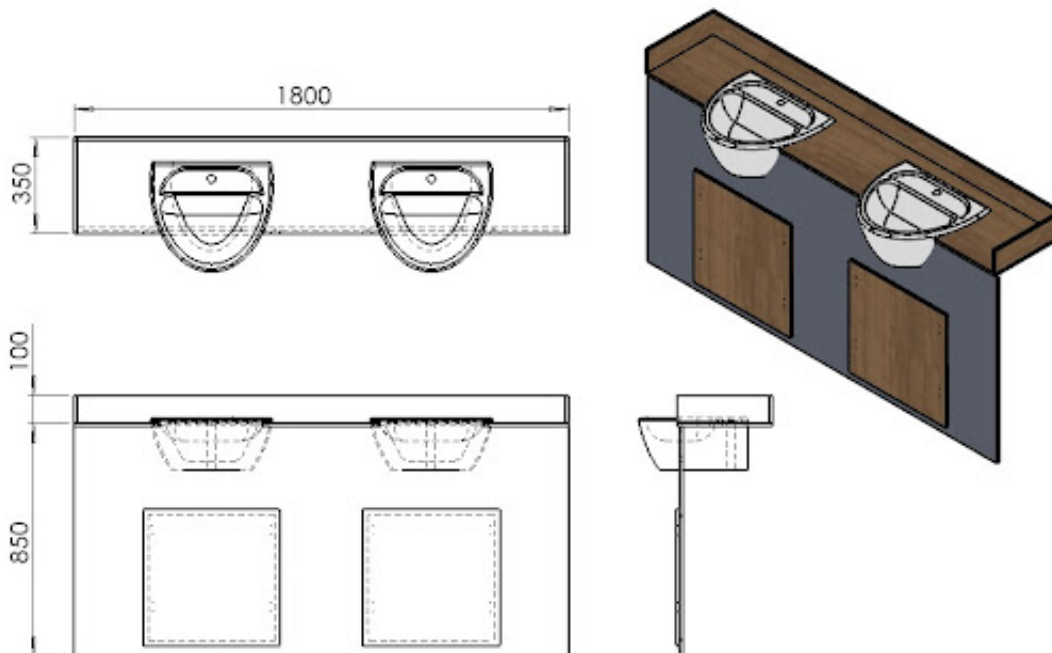

Finished panels both sides

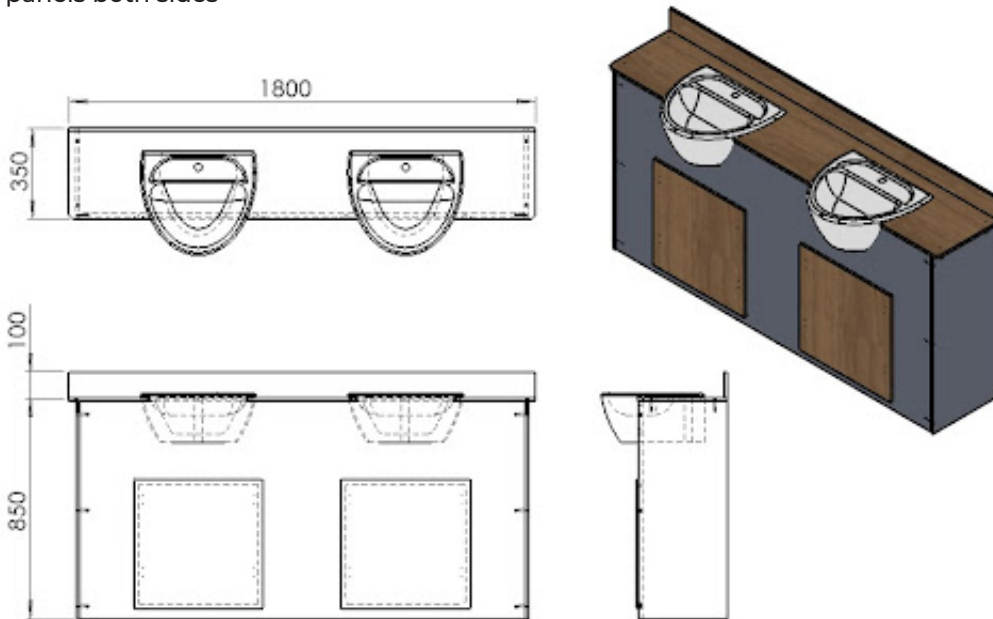

Finished panel to either RH/LH end (to fit from corner)

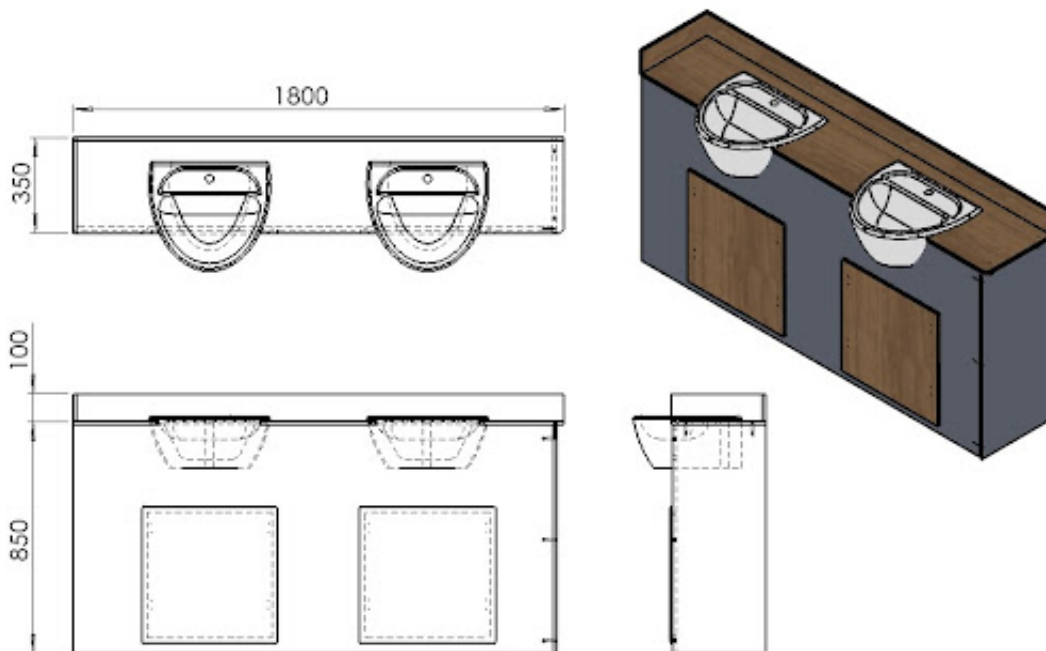

## IPS / Ducting

As with our cubicles & vanity units we also construct our IPS (integrated Plumbing Systems) from SGL Panelling.

We use timber to create a sturdy frame to mount/hang the SGL panelling from which is protected from water ingress when the panels are fitted and sealed to the floor & walls.

Each IPS has lift off or push fit panels depending on configuration for access to easy access to plumbing fitting/service/repair work.

IPS is not always essential as you can use traditional toilets with exposed cisterns but for a seamless more attractive solution IPS can be used to conceal the majority of pipework and still allow for maintenance.

These all can be wall to wall or into a corner to match your cubicle layout. Also available for single or trough urinals if required.



## Typical Layouts

Floor to ceiling creating essentially a false wall with removable panels for access to plumbing

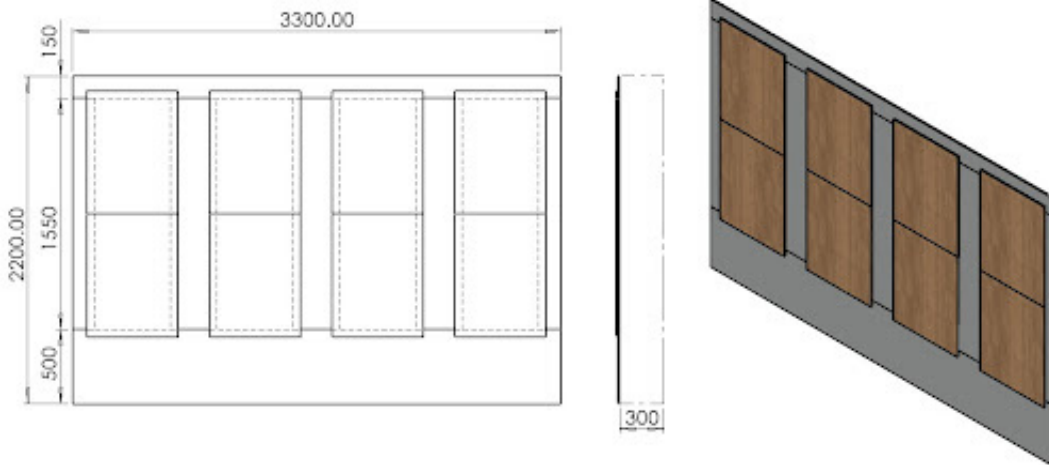

Full height to match cubicles Adult 1962mm (1950mm + upper cover panel) with removable panels for access to plumbing

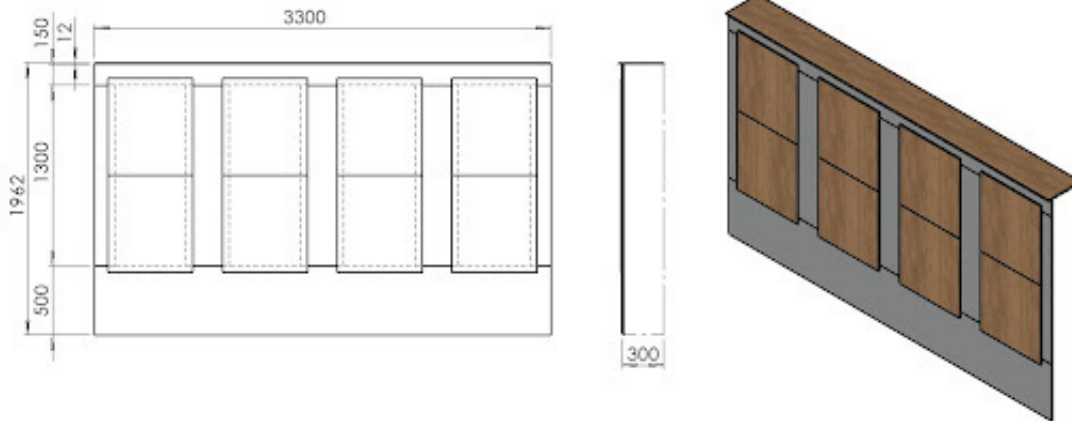

Short typically around 1300mm with one lift off and removable top for access to plumbing (generally used for children's washrooms to match the smaller shaped end of the divisions), these can all be wall to wall or into a corner to match your cubicle layout.

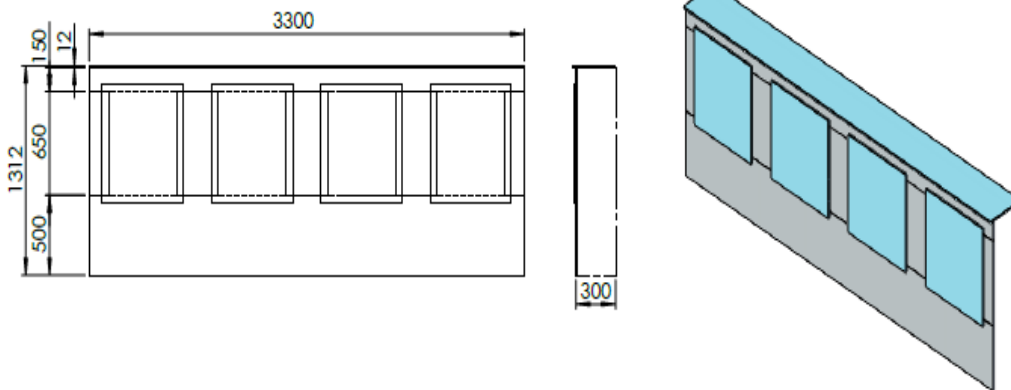

Also available for single or trough urinals if required, although many are wall hung this can help hide unsightly pipework.

## Full Turnkey Solution

We can also take care of the entire installation for you including supply and installation of components including sinks & toilets wall cladding & flooring.

To compliment your freshly installed cubicles & vanity units we can offer installation of robust vinyl floor and PVC wall cladding. Both are easy clean & hygienic , also a lot quicker to install than tiling to minimise disruption and down time of your WC.

As a standard we offer 2 Different Semi Recessed Sinks to fit in our vanities, other sinks are available but may incur additional cost due to templating

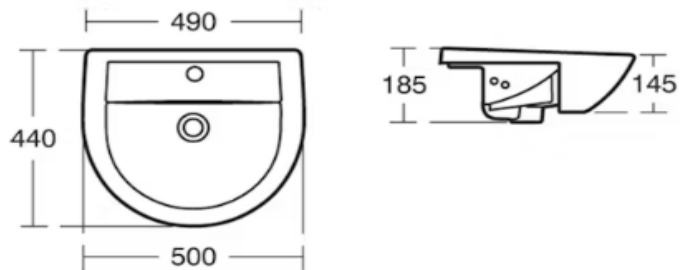

Armitage Shanks Sandringham 21 Semi-Recessed Basin 50cm  
Available with 1 or 2 tap holes

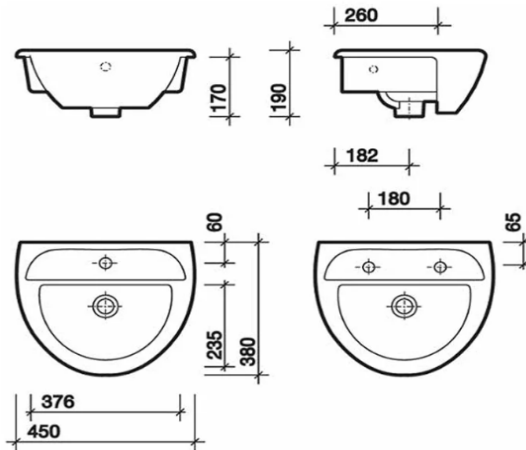

Twyford Sola Optimise Semi-recessed Basin 450mm Wide  
Available with 1 or 2 tap holes

All available with a variety of taps to fit your needs whether it is a push button or levered mixer.  
We can provide a toilet to fit the end users' needs from little ones in nursery to full size adult toilets.



Any other sanitaryware items and complementary accessories from made to measure Trough sinks & urinals to hand towel dispensers , toilet roll holders we can provide and install.

Alongside these options with our ability to manufacture from scratch we can offer other products to go alongside your cubicles e.g storage cupboards, lockers, coat rails and many more , please get in touch with our sales team to discuss your ideas; we can make most things a reality.











**BRITISH MADE FURNITURE  
BUILT TO LAST**



**Amanda Shepherd**  
Sales Director



**Frances Condren**  
Senior Estimator



**Tracey Hardman**  
Account Manager



**Chris Gustafsson**  
Account Manager



**Megan Dresser**  
Accounts / Sales

**0191 389 1888**

[sales@ambicmanufacturing.com](mailto:sales@ambicmanufacturing.com)

[www.ambicmanufacturing.com](http://www.ambicmanufacturing.com)

**House of Ambic  
Stella Gill Industrial Estate  
Pelton Fell, Chester-le-Street  
County Durham, DH2 2RN**